



This is a digital copy of a book that was preserved for generations on library shelves before it was carefully scanned by Google as part of a project to make the world's books discoverable online.

It has survived long enough for the copyright to expire and the book to enter the public domain. A public domain book is one that was never subject to copyright or whose legal copyright term has expired. Whether a book is in the public domain may vary country to country. Public domain books are our gateways to the past, representing a wealth of history, culture and knowledge that's often difficult to discover.

Marks, notations and other marginalia present in the original volume will appear in this file - a reminder of this book's long journey from the publisher to a library and finally to you.

### **Usage guidelines**

Google is proud to partner with libraries to digitize public domain materials and make them widely accessible. Public domain books belong to the public and we are merely their custodians. Nevertheless, this work is expensive, so in order to keep providing this resource, we have taken steps to prevent abuse by commercial parties, including placing technical restrictions on automated querying.

We also ask that you:

- + *Make non-commercial use of the files* We designed Google Book Search for use by individuals, and we request that you use these files for personal, non-commercial purposes.
- + *Refrain from automated querying* Do not send automated queries of any sort to Google's system: If you are conducting research on machine translation, optical character recognition or other areas where access to a large amount of text is helpful, please contact us. We encourage the use of public domain materials for these purposes and may be able to help.
- + *Maintain attribution* The Google "watermark" you see on each file is essential for informing people about this project and helping them find additional materials through Google Book Search. Please do not remove it.
- + *Keep it legal* Whatever your use, remember that you are responsible for ensuring that what you are doing is legal. Do not assume that just because we believe a book is in the public domain for users in the United States, that the work is also in the public domain for users in other countries. Whether a book is still in copyright varies from country to country, and we can't offer guidance on whether any specific use of any specific book is allowed. Please do not assume that a book's appearance in Google Book Search means it can be used in any manner anywhere in the world. Copyright infringement liability can be quite severe.

### **About Google Book Search**

Google's mission is to organize the world's information and to make it universally accessible and useful. Google Book Search helps readers discover the world's books while helping authors and publishers reach new audiences. You can search through the full text of this book on the web at <http://books.google.com/>



PROPERTY OF  
*University of  
Michigan  
Libraries*  
1817  

---

ARTES SCIENTIA VERITAS

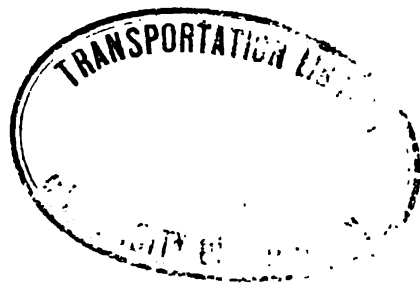



PROPERTY OF  
*University of  
Michigan  
Libraries*  
1817  
ARTES SCIENTIA VERITAS













FIFTY-FIFTH QUARTO VOLUME

Transportation  
Library

TF  
1

.R13

From July 1, 1913, to December 31, 1913

# Railway Age Gazette

(Established in April, 1856)

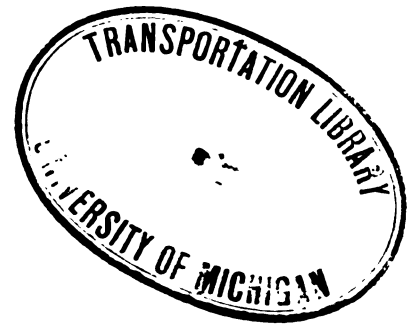

FIFTY-EIGHTH YEAR

NEW YORK

CHICAGO

CLEVELAND

LONDON

1913

SECOND HALF



# INDEX

Fifty-fifth Quarto Volume—July 1, 1913, to December 31, 1913.

## AUTHORS

- Abbott, R. B., 773, 1113  
Airey, W. C., 1011  
Allix, G., 1232  
Arnold, Bion J., 1078  
Auryansen, F., 508
- Babcock, Allen H., 447  
Bailey, N. E., 216  
Basford, G. M., 7  
Baumgartner, J. Hampton, 90  
Bentley, F. W., Jr., 292  
Boyd, George W., 1220  
Bruce, John, 1010  
Blaiklock, M. S., 970  
Borden, H. P., 365  
Bradt, Charles E., 855†  
Brown, W. E., 646  
Buell, D. C., 221  
Burnett, R. W., 1075
- Carpenter, A. W., 971  
Childers, H. W., 1154  
Clark, George A., 663  
Clough, A. M., 980  
Collett, Robert, 874  
Colson, M. Clement, 919  
Cox, James, 1115  
Crawford, D. F., 762, 902  
Crites, George S., 1192  
Curran, Arthur, 1154
- Defibaugh, Charles H., 1155  
De Groot, E. H., Jr., 403  
Delano, F. A., 1025  
de Muralt, C. L., 230, 418  
Donovan, P. H., 415  
Dunn, Col. B. W., 23  
Dunn, Samuel O., 1065  
Dunning, S. W., 650
- Elliott, Howard, 565, 615, 1115  
Ely, Owen, 137
- Fair, J. M., 504  
Freeman, Lewis R., 191, 327, 657  
Frith, A. C., 6  
Fritts, J. C., 499  
Fulcher, Nelson, 1156
- George, H. F., 1012  
Glenn, M. C., 1009
- Hae, Arthur, 175, 363, 602  
Hamilton, Frank, 1009  
Hamilton, P. H., 299  
Hansen, A. E., 770  
Haycock, Winters, 218  
Hayes, Raymond V., 450  
Henderson, G. R., 174  
Hill, James J., 821  
Hill, J. Garrett, 414
- Hine, Major Charles, 702  
Holland, R., 978  
Houston, H. A., 455  
Hooper, William E., 954  
Hopkins, E. T., 1113  
Houston, Harold A., 958  
Hulit, A. B., 140  
Hurd, E. C., 744  
Huustis, James H., 565
- Johnson, Alba B., 271  
Jones, Arthur B., 871  
Josephs, L. C., Jr., 828
- Kane, Martin, 983  
Kerr, R. E., 617  
Keyser, 990  
King, Coleman, 772  
Kipp, A., 765  
Klapp, James O., 1225  
Knowles, C. R., 289  
Kraemer, M. J., 1155  
Krake, H. G., 694
- La Bach, Paul M., 55, 1035, 1214  
Landon, H. C., 287  
Lauck, E. C., 1157  
Lee, Blewett, 767  
Lee, Ivy L., 49  
Leeds, J. S., 569  
Leigh, E. B., 1161  
Lemmerich, Gustave E., 189, 320  
Leonard, F., 968  
Lewis, E. R., 771  
Linn, John H., 1023  
Lisman, F. J., 363  
Loesch, Frank J., 659  
Lord, Arthur R., 321  
Low, Emile, 282  
Lucore, F. M., 403
- McColvin, E. L., 138  
Macdonald, J. A., 1186  
McKenzie, Edward F., 901  
Mellen, Charles S., 918  
Meredith, E. R., 1176  
Milner, B. B., 279  
Modjeski, Ralph, 558  
Moon, B. H., 1185  
Moore, L., 655  
Morgan, J. J., 259, 981  
Morrison, C. J., 84  
Morrow, John D. A., 656  
Morse, F. L., 743
- Newcomb, H. T., 139
- Patton, F. E., 743, 1156  
Peter, S. B., 526  
Pomeroy, L. R., 274
- Pratt, J. R., 645  
Prichard, Henry S., 646
- Quigley, W. S., 819
- Rear, G. W., 973  
Redfearn, B. W., 568  
Riley, C. C., 555  
Riney, M., 116  
Rink, George W., 1081  
Ripley, E. P., 1020  
Rizer, F. W., 293  
Roberts, S. S., 504  
Rommel, C. T., 91, 364  
Rose, George W., 1012  
Rudd, A. H., 625
- Sabin, A. H., 984  
Schall, F. E., 969  
Schnatterbeck, Charles C., 5  
Schuster, K. R., 259  
Secrist, C. M., 568  
Sheafe, J. S., 711, 915  
Smith, C. E., 45  
Stradling, E. G., 110  
Street, Clement F., 136  
Stretton, Clement E., 83  
Sutherland, M. R., 1153  
Swartz, A., 773  
Swergal, E. E., 421
- Thomas, C. H., 118  
Thompson, A. I., 21  
Thompson, John S., 980  
Thorne, Clifford, 1020  
Tinker, J. H., 1018  
Townsend, W. B., 1159  
Turnbull, W. F., 137  
Turner, Avery, 6, 364  
Turner, J. K., 1165  
Turner, Walter V., 415  
Tyrrell, Henry Grattan, 1230
- Van Auken, C. L., 1191
- Walker, Edward W., 1156  
Walker, W. K., 972, 979  
Weller, R. C., 1153  
Wells, M. E., 563  
Whigelt, George, 984  
Willard, Daniel, 1025  
Williams, J. C., 983  
Wilson, Gordon, 830  
Wilson, William G., 982  
Wishart, J. G., 793  
Wollner, William S., 1117, 1187  
Wood, Walter D., 13, 83, 174  
Worthington, B. A., 371, 872
- Yeomans, George G., 857

# GENERAL INDEX

[Illustrated articles are indicated thus\*; Editorials thus†; Letters to Editor thus‡.]

- A**
- Accident:**  
 American Railway Association and Railway Accidents, 852†  
 Automobile Accidents and Train Accidents, 27, 741†  
 Automobile Accidents and White Flags, 576  
 Automobile Safety Committee, 469  
 Automobiles and Grade Crossings, 64, 360†, 991  
 Block System and the Train Despatcher, 258†  
 Brooklyn Rapid Transit at Jamaica Bay, 26  
 Canadian Pacific near Ottawa, Ont., 26  
 Central London at Shepherd's Bush, 1150†  
 Central New England near Pleasant Valley, N. Y., 301  
 Central of Georgia near Clayton, Ala., 993  
 Chicago, Milwaukee & St. Paul near Forsythe, Mont., 714  
 Cleveland, Cincinnati, Chicago & St. Louis near Stockwell, Ind., 814\*  
 Committee, Accident; Pennsylvania Railroad, 714  
 Denver, Boulder & Western at Eldorado, Col., 198  
 Doherty, Engineman, Released, 240  
 Enginemen and Accidents, 743†  
 Equipment not to be Burned; Pennsylvania Railroad, 714  
 Erie, Construction Train, 198  
 First Aid Instruction, 259†  
 France, near Nice, 576  
 Interstate Commerce Commission Bulletin No. 46, 383; No. 47, 759  
 Legislation, Plea Against Hasty, 449  
 Lehigh Valley near Slatington, Pa., 200  
 Liverpool, England, 714  
 Locomotive Failure, Early, 6†, 83†, 768  
 Maintenance Standpoint, Accidents from, 515  
 Manslaughter, Two Months for, 834  
 Meeting-Point Rule, 344  
 Mexico, near Saltillo, 576  
 Midland Railway of England near Hawes Junction, 428  
 Missouri Pacific at Brant, Mo., 270  
 Mobile & Ohio at State Line, Miss., 795  
 Monthly Summaries: June, 182; July, 329; August, 627; September, 860; October, 965  
 New York, New Haven & Hartford at Frankford, 161  
 New York, New Haven & Hartford at North Haven, 397†, 427, 441†, 442†, 461, 471, 482†, 575, 577, 599†, 602†, 619, 622, 628, 630  
 New York, New Haven & Hartford at Stamford, 79†, 82†, 94, 125, 138†  
 Pacific Electric near Los Angeles, Cal., 119  
 Panama Railroad at Paraiso, 926  
 Paris, Lyons & Mediterranean at Melun, France, 879, 1037  
 Pennsylvania Railroad at Tyrone, Pa., 201, 494\*  
 Pennsylvania Railroad, near Wileys, Ohio, 575  
 Pennsylvania Railroad Record, 26  
 Publicity to Accidents, 740†  
 Reducing, Methods of, 978  
 Rescue of Passengers from a Flood, 345  
 Responsibility and Duty, Sense of, Wanted, 482†, 743†  
 Rochester & Eastern at Victor, N. Y., 198  
 Safety First (See Safety First)  
 Safeguards, Adjunctive, 689†  
 Safety at Grade Crossings, 527  
 Safety in Maintenance of Way Department, 1185  
 Safety in the Paint Shop, 497  
 Safety Loading of Logs, 301  
 Safety of Railroad Travel, 715, 927  
 Schroeder, Engineman, Acquitted, 4†  
 Southern Pacific, Boiler Explosion, 159  
 Steel Equipment and Accidents, 743†  
 Surprise Checking, Pennsylvania Railroad, 715  
 Trespass Problem, 640†, 667  
 Trespassers Appealed to, 1037  
 Trespassers on the New York Central, 255†, 267\*  
 Trespassers, Warning to, 575
- Accounting** (See also Association of Transportation and Car Accounting Officers; also Society of Railway Financial Officers):  
 Abandoned Property, Kansas City Southern Decision, 1093, 1107†  
 Cost and Efficiency, 39†, 58, 137†  
 Statistical Information Practices, 213†  
 System of Accounts, Interstate Commerce Commission, 954  
 Train Auditors on the M. K. & T., 1137
- Acetylene** (See Lighting)
- Acworth, W. M.:** Observations in America, 1137
- Aeroplane Flights,** 160, 198, 240, 242, 301, 576, 628, 878
- Agriculture:**  
 Boll Weevil, War Against, 142  
 Cotton Production in 1912, 31
- Agriculture (Continued):**  
 Dairy, Model, Pennsylvania Railroad, 342\*  
 Demonstration Trains, 473, 533, 717, 797, 881, 1140  
 Development Department, Ann Arbor, 715  
 Development of the Southern States, 883  
 Farm Marketing to be Developed on St. L. & S. F., 1140  
 Hampden County Improvement League, 29  
 Kansas Bankers' Association and Farmers, 29  
 Railways' Interest in Better Farming, 1006†  
 Roads, Good, Pay for Themselves, 122  
 Stock Raising to be Developed; Waycross & Western, 1090  
 State Colleges, Campaign of, 1039  
 Weeds, Damage by, 1036
- Air Brake** (See Brake)
- Air Compressor** (See Compressed Air)
- Alaska:**  
 Government Ownership of Railways, 6†  
 President Wilson Favors Railroad Project, 1086  
 Railway Development Needed, 421\*  
 Alcohol Heating & Lighting Company: Heater Car Tests, Alcohol, 53\*
- American Association of Railroad Superintendents:**  
 Annual Convention, 358†, 374, 549†  
 Wheatly, W. W., Address of, 397†
- American Car & Foundry Company:** Steel Frame Box Car, St. L. & S. F., 598†, 609\*
- American Electric Railway Claims Association:**  
 Publicity to Accidents and Delays, 740†
- American Foundrymen's Association:** Powdered Coal as Fuel, 819
- American Institute of Consulting Engineers:** Engineer Recommended for I. C. C., 1135
- American Iron & Steel Institute:** Wrought Steel Wheel, 902
- American Locomotive Company:**  
 Annual Report, 362†  
 Powerful Locomotives, Northern Pacific, 377\*
- American Lock Nut Company:** Absolute Lock Nut, 1194\*
- American Railway Association:**  
 Accident Prevention, 852†  
 Demurrage Agreements, Proposed Extension of, 425\*  
 Labor Economy, 769†  
 Meeting at Chicago, 1087  
 Scale Shops, 300
- American Railway Bridge & Building Association:**  
 Annual Convention, 769†, 784  
 Cattle Guards, 769†, 788†  
 Motor Cars for Bridge Gangs, 786  
 Preservation of Timber, 791  
 Sewers and Drains, 786  
 Snow Fences, 790  
 Temporary Structures for Supporting Tracks, 787  
 Water Supply, 784
- American Railway Engineering and Maintenance of Way Association** (See American Railway Engineering Association)
- American Railway Engineering Association:**  
 Seams in Rails, 1082  
 Statistics of Failed Rails, 529
- American Railway Safety Association:** Convention, 564
- American Railway Tool Foremen's Association:**  
 Annual Convention, 158, 178
- American Society for Testing Materials:**  
 Annual Meeting, 15\*  
 Reports, Unsatisfactory, 172†
- American Society of Mechanical Engineers:**  
 Human Element in Industrial Management, 135†  
 Box Car Design Problems, 1123  
 Grashof Medal Presented to George Westinghouse, 1136  
 Sheathed Steel Frame Box Cars of C. P. R., 1075\*  
 Steel Underframe Box Cars, 1081
- Ann Arbor:** Department of Development, 715  
 Annual Reports (See names of companies)  
 Apprentice (See Education)
- Arbitration:**  
 Chicago & Western Indiana, 241, 469, 527, 597†  
 Chicago, Burlington & Quincy, 878  
 Board of Conciliation and Mediation, 134†, 155\*  
 Conductors and Trainmen, 26, 66, 81†, 119, 134†, 150, 155\*, 200, 241, 343, 528, 575, 630, 666, 897†, 899†, 909, 927  
 New Arbitration Law, 81†  
 Southern Pacific, Electric Lines, 343, 357, 387
- Arch** (See Bridges and Buildings)
- Arkansas & Memphis Railway Bridge & Terminal Company:** Memphis Bridge, 824\*
- Arizona Eastern:** Novel and Effective Cattle Guard, 1186\*
- Arizona Eastern:**  
 Novel and Effective Cattle Guard, 1186\*  
 Office Building for Hine System, 827\*
- Armspear Manufacturing Company:** Spheroidal Lens, 502\*, 795
- Associated Engineering Societies of St. Louis:**  
 Kaw River Bridge Reconstruction, 45\*
- Association of Railway Electrical Engineers:**  
 Convention, 756  
 Gas-Electric Car, 828\*
- Association of Transportation and Car Accounting Officers:** Summer Meeting, 60
- Atchison, Topeka & Santa Fe:**  
 Annual Report, 811†, 846  
 Apprentices, Choosing from, 2†, 7\*, 40†  
 Loss and Damage Committee, 694†  
 Oil Contract, 794  
 Refrigerator Service Promised, 997  
 Scrap Reclaiming, 260\*, 278†, 739†
- Audible Signaling** (See Signaling)
- Auditing** (See Accounting)
- Australia:** Gage Standardization, 40†
- Automatic Stops** (See Signaling)
- Axle** (See Wheel)
- B**
- Baggage:**  
 Rules; Pennsylvania Railroad, 714  
 Punching Tickets for Baggage Transportation, 579
- Baldwin Locomotive Works:**  
 Letter of M. W. Baldwin, 427  
 Pacific Type Locomotives, C. & O., 571\*
- Ballast:** Burning Earth for Ballast, 343
- Baltimore & Ohio:**  
 Anniversary Celebration at Wheeling, 89  
 Annual Picnic, 161  
 Annual Report, 1007†, 1050  
 Care of Passengers, 666  
 Concrete Tanks, 1183\*  
 Engine Terminal at Cumberland, Md., 709\*  
 Flood Reconstruction, 99†, 106\*  
 Safety First Clock, 576  
 Safety Work, 301  
 Staff Meeting, 629  
 Ticket Agents' Contest, 714, 966  
 Trespassers Appealed to, 1037
- Baltimore Western Dispatch,** 717
- Bangor & Aroostook:** Contracts with Employees, 240
- Bascule** (See Bridges and Buildings)
- Bearings:** Steel Journal Box, 966\*
- Bessemer & Lake Erie:** Transportation System, 491\*
- Bills of Lading:** Cotton Bills of Lading, 536, 669
- Block Signal** (See Signal, Block)
- Boiler** (See Locomotive Boiler)
- Boiler Inspection:** Report of Chief Inspector, 1209†, 1233
- Boston & Maine:**  
 Effect of Law Regulating Security Issues, 1150†  
 Extension from Hinsdale, N. H., to Brattleboro, Vt., 661\*  
 Joint Report on B. & M. Freight Rates, 1201  
 Signals at Junction Points, 1108†  
 Yard at Mechanicville, N. Y., 775\*
- Brake** (See also Air Brake Association):  
 Air Brake Hose (See Hose)  
 Air Brakes and Modern Conditions, 415  
 Care of Locomotive Brake Equipment, 337
- Brandeis, Louis D.,** 687
- Bridges and Buildings:**  
 Angle Iron Clips for Bridge Stringers, 781\*  
 Bascule Bridge, Double Deck, 603\*  
 Bridge Inspection on the B. R. & P., 1178  
 Bridge at Rome, N. Y.; N. Y. C. & H. R., 282\*  
 Concrete Buildings, D. L. & W., 511\*  
 Economical Bridge Erection, 1193\*  
 Fireproof Bridges and Fires, 769†  
 Foremen, Don'ts for Bridge, 981  
 High Cantilever Bridge in Mexico, 1222\*  
 Inspection Methods, 968†, 969\*  
 Jamaica Office Building, Long Island, 183\*, 508\*  
 Kaw River Bridge Reconstruction, 45\*  
 Kenova Bridge, Norfolk & Western, 400†, 407\*  
 Louisville & Nashville Bridge Work, 143\*, 225\*  
 Memphis Bridge, Arkansas & Memphis Railway Bridge & Terminal Company, 824\*  
 Motor Cars for Bridge Gangs, 786  
 Office Building for Hine System, 827\*  
 Opening Bridges, Preliminary Considerations in the Design of, 1230  
 Organization for Bridge Building, 116  
 Paint, Tests of Bridge, 1179  
 Quebec Bridge, 365\*, 559\*  
 Raising Track or Building Trestle, 1188  
 Schuylkill River Bridge Improvements, 1173\*  
 Swing Spans, Double Track, Renewing, 690\*  
 Trestles over Newark Bay Rapidly Rebuilt, 24
- Brooklyn Rapid Transit:**  
 Accident at Jamaica Bay, 26  
 Annual Report, 485†, 543

Brooklyn Rapid Transit (*Continued*):  
 Brakes for New York Street Cars, 125  
 Medical Inspection Bureau for Employees, 63  
 Buchanan & Northern: Construction, 598†, 617\*  
 Buffalo, Rochester & Pittsburgh:  
 Annual Report, 318†, 355  
 Device for Loading Ties, 1181\*  
 Bridge Inspection, 1178  
 Building (See Bridges and Buildings)  
 Bumping Posts, Necessity for, 741†  
 Bureau of Railway Economics:  
 Meeting, 795  
 Revenues and Expenses for May, 203\*; for June, 535\*; for July and August, 881\*; for September, 1040\*  
 Bureau of Railway News and Statistics: Railway Earnings for 1912-13, 630  
 Bureau of Standards of Department of Commerce: Standard Scale Test Car, 114, 985\*

C

Cab Signal (See Signaling)  
 Canada:  
 Freight Cartage, Free, Abolished, 68  
 Rail Production in 1912, 388  
 Safety Appliances, U. S., Required, 119  
 Canadian Government Railways: Discipline Without Suspension, 530  
 Canadian Locomotive Company: Power Reverse Gear, 713\*  
 Canadian Northern:  
 Montreal Terminal, 640†, 651\*  
 Safety Loading of Logs, 301  
 Canadian Pacific:  
 Accident near Ottawa, Ont., 26  
 All-Steel Trucks, 1163\*  
 Annual Report, 400†, 438  
 Bascule Bridge, Double Deck, at Fort William, 603\*  
 Box Car for Grain and Coal Traffic, 57\*  
 Dining Car Service, 470  
 First Aid to Injured Car, 469  
 Funded Debt, 39†  
 Heater Car Tests, Alcohol, 53\*  
 Oil as Fuel, 386  
 Sheathed Steel Frame Box Cars, 1075\*  
 Canal (See Waterways)  
 Capitalization (See Finance)  
 Car:  
 Ballast Car, Repairing, 990  
 Bearings (See Bearings)  
 Box Car for Grain and Coal Traffic, Canadian Pacific, 57\*  
 Box Car, Steel Frame; St. L. & S. F., 598†, 609\*  
 Business Cars, Pennsylvania Railroad, 628  
 Carlines, Pressed Steel, 425\*  
 Convertible Stock and Box Car, 1126\*  
 Coupler and Draft Sill Repairs, 1055†  
 Coupler Release Rigging, 1168\*  
 Dairy Car, Pennsylvania Railroad, 342\*  
 Design of Box Car Problem, 1123  
 Door, Mail Car, 240\*  
 Dump Car, Automatic Air, 295\*  
 End Construction for Pullman Cars, New, 231\*  
 Export of British and American Cars, 572  
 First Aid to Injured Car, 469  
 Freight Cars in Service, 458  
 Gas-Electric Car, 828\*  
 Gasolene (See Motor Car)  
 Heater Car Tests, Alcohol, 53\*  
 Hospital Car, C. R. I. & P., 748\*  
 Inspection (See Motor Car)  
 Interchange (See Car Service)  
 Lighting (See Lighting)  
 Link Side Bearing Truck, 1167\*  
 Loading of Coal Cars, Proper, 1083\*  
 Lunch Counter Car, Pennsylvania, 1086  
 Machine Car for Construction Work, 285\*  
 Motor (See Motor Car)  
 Painting (See Paint)  
 Quarry Car, 510\*  
 Repairs, Need for, 43†  
 Safety Appliances (See Safety Appliances)  
 Safety Exhibit Car, N. Y. C. & H. R., 213†, 228\*  
 Scale Test Car, U. S. Bureau of Standards, 114, 985\*  
 Scoop Car for Removing Slides, 987\*  
 Sheathed Steel Frame Box Cars of C. P. R., 1075\*  
 Slack Adjuster (See Brake)  
 Stake Pocket, Collapsible, 1169\*  
 Steel Underframe Box Cars, 1081  
 Steel Passenger Car Increase, 257†, 269  
 Steel Passenger Train Car Situation, 941†, 947\*  
 Troubles, Freight Car, 499\*  
 Truck (See Truck)  
 Ventilation (See Ventilation)  
 Wheel (See Wheel)  
 Car, Freight (See Car)  
 Car, Passenger (See Car)  
 Car Service (See also American Association of Demurrage Officers; also American Railway Association; also Interstate Commerce Commission Rulings; also Association of Transportation and Car Accounting Officers):  
 Car Balance and Performance, March, 29\*; April, 306\*; May, 474\*; June, 669\*; July, 930\*; August, 1202\*  
 Car Shortage, Activity to Prevent, 575

Car Service (*Continued*):  
 Car Shortages, Causes and Remedies for, 359†  
 Car Shortage Circular of the Interstate Commerce Commission, 798  
 Car Shortage, Co-operation to Prevent, 199, 428, 473  
 Car Shortages, E. P. Ripley on, 406  
 Congestion on the Prussian State Railways in 1912, 1209†, 1232  
 Demurrage Agreements, Proposed Extension of, 425\*  
 Demurrage as a Remedy for Car Shortages, 1225  
 Demurrage in Texas, 68  
 Distributing Rules, Sunset Central Lines, 1086  
 Freight Car Earnings, 646†  
 Government Owned Cars, 414  
 Inspection of Box Cars, Overhead, 898†  
 Interchange Car Inspection, 376  
 Loading of Cars, Increasing, 810†, 830  
 Loading of Coal Cars, Proper, 1083\*  
 Movement, Increasing Freight Car, 175, 363†, 371, 399†, 403, 549†, 555, 579, 597†, 602†, 646, 992 (See also Yards and Terminals; Efficiency in Yard Service)  
 Pooling of Freight Cars, 430, 941†, 957, 963  
 Pooling of Freight Cars Under Government Ownership, 398†  
 Repairs, Need for, 43†  
 Track Storage Charge, 121  
 Car Service Commission (See American Railway Association)  
 Car Shortage (See Car Service)  
 Carolina, Clinchfield & Ohio: Clinchfield Extension, 861\*  
 Cattle Guards, 769†, 788  
 Cattle Guard, Novel and Effective: Arizona Eastern, 1186\*  
 Cement (See Concrete)  
 Center of Gravity, Finding, 381\*, 413  
 Central of Ga.:  
 Accident near Clayton, Ala., 993  
 Educational Bureau, 63  
 Central New England: Accident near Pleasant Valley, 301  
 Central R. R. of N. J.:  
 New Jersey & Pennsylvania, Operation of, Stopped, 794  
 Renewing Two Double Track Swing Spans, 699\*  
 Traveler for Dismantling a Train Shed, 115\*  
 Central Ry. Club: Standard Test for Draft Gears Recommended, 499\*  
 Chambersburg Engineering Co.: Press, Hydraulic Forging and Bending, 665\*  
 Chase, Charles J., 73  
 Chesapeake & Ohio:  
 Annual Report, 642\*†, 681  
 Operating Study, 1053†, 1061\*  
 Pacific Type Locomotives, 571\*  
 Ticket Coupon Redemption Committee, 243, 473  
 Yard at Silver Grove, Ky., 117\*  
 Chicago:  
 Freight Terminal, M. St. P. & S. S. M., 321\*  
 Passenger Traffic, 1125  
 Smoke Problem, 239  
 Development of Railway Facilities, Proposed, 27, 64, 118, 320†, 388, 666, 992, 1078\*, 1088, 1125, 1136, 1237  
 Chicago, Burlington & Quincy:  
 Annual Report, 854†, 893  
 Arbitrators Selected, 878  
 Bridge Inspection Methods, 968†, 974  
 Construction Organization, 99†, 111  
 Dining Car Service to the Pacific Coast, 797  
 Legislative Retaliation Threatened for Refusal to Issue Passes, 1053†, 1097  
 Operating Study, 85\*  
 Relief Department, 386  
 Reports, Daily Time and Material, 503†, 505\*  
 Chicago & Eastern Illinois: Silence for Sleepers, 358†  
 Chicago Great Western: Refunds During Rate Litigation, 26  
 Chicago, Indianapolis & Louisville: Flood Reconstruction, 99†, 110\*  
 Chicago, Milwaukee & St. Paul:  
 Accident near Forsythe, Mont., 714  
 Electrification Progress, 1236  
 Milwaukee Improvements, 19\*  
 Searchlight on Observation Cars, 160  
 Chicago & New Orleans Transportation Company, 243  
 Chicago & Northwestern:  
 Annual Report, 552†, 590  
 Foreign Representatives, 837  
 Officers, Length of Service, 992  
 Reports, Daily Time, 503†, 506\*  
 Safety First Results, 160, 992  
 Signal Instruction, 1236  
 Station Work Organization, 52  
 White Audit System Discontinued, 837  
 Chicago, Rock Island & Pacific:  
 Annual Report, 691†, 733  
 Dead Line for Station Platform, 426\*

Chicago, Rock Island & Pacific (*Continued*):  
 Fire Prevention Day, 1135  
 Hospital Car, 748\*  
 Merritt and Demerits, 64  
 Pass Form, New, 275\*  
 Train of 99 Cars Hauled 111 Miles by One Locomotive, 270  
 Y. M. C. A. Building, 834  
 Chicago, St. Paul, Minneapolis & Omaha: Annual Report, 554†, 594  
 Chicago Transportation Association: Educational Bureau, 837  
 Chief Interchange Car Inspectors' and Car Foremen's Association: Interchange Rules, Interpretation of, 457  
 Christmas Present Giving, 897†  
 Claims:  
 (See also Interstate Commerce Commission Rulings; also State Commission Rulings; also Freight Claim Association Claim Department—An Asset, 655  
 Containers, Unsatisfactory, and Claims, 23  
 Frauds Punished, 244  
 Freight Claim Blanks, 341\*  
 Inspection of Box Cars, Overhead, 898†  
 Loss and Damage Committee, A. T. & S. F., 694†  
 Mules Tied to Tracks, 628  
 Weeds, Damage by, 1036  
 Clapp Fire Resisting Paint Company, 293\*  
 Classification:  
 Permanent Western Classification Committee, 1108†, 1140  
 Uniform Freight Classification, 1041  
 Cleaning (See Sanitation)  
 Clearances, 967†  
 Clearing House (See Accounting)  
 Cleveland Car Specialty Company: Pressed Steel Carlines, 425\*  
 Cleveland, Cincinnati, Chicago & St. Louis: Divisional Organization Discontinued, 1135  
 Wreck Caused by a Broken Tire, 814\*  
 Clubs, Suggestions for, 599†  
 Coal (See Fuel)  
 Competition:  
 Enginemen's Lookout, 257†  
 Foreman Problem, 526  
 Proper Handling of Work Trains, 967†  
 College Man and the Railroads, 49, 99†  
 Colorado & Southern: Annual Report, 1158\*†, 1101  
 Commerce Court:  
 (See also Interstate Commerce Commission; also Interstate Commerce Commission Rulings; also Legal Decisions; also Legislation)  
 Abolition of, 470  
 Louisville & Nashville Case, 475  
 Movement to Abolish, 575, 666  
 Work, Cessation of, 33  
 Committee on Relations of Railway Operation to Legislation:  
 Information Regarding Pending Legislation, 315†  
 Legislation Relating to Operation, 256†, 270, 277†  
 Steel Passenger Equipment Increase, 257†, 269  
 Commonwealth Steel Co.: Tender Truck, Equalized Swing Motion, 386  
 Commuters' Prize, 530  
 Compressor: Portable Compressor with White-washing Device, 292\*  
 Concrete (See also Bridges and Buildings)  
 Alkali and Sea Water, Action on (cement of, 514  
 Buildings, D. L. & W., 511\*  
 Concrete Surfaces, Treatment of, 984  
 Foundations for Heavy Service Track, 508\*  
 Slope of Chutes, 1177  
 Tanks, Concrete, 1171†  
 Tanks, on B. & O., 1183\*  
 Telegraph Poles, Reinforced Concrete, 286  
 Ties, Design of Concrete, 259†  
 Water Trough, Concrete, 783\*  
 Consolidation (See Finance)  
 Control (See Finance; also Government Regulation)  
 Construction, New:  
 Boston & Maine, Hinsdale, N. H., to Brattleboro, Vt., 661\*  
 Buchanan & Northern, 598†, 617\*  
 Clinchfield Extension, C. C. & O., 861\*  
 Experiment on Track Construction, 277†, 279\*  
 Foundations, Concrete, for Heavy Service Tracks, 508\*  
 Grand Trunk Pacific, 715  
 Lack of Data of Cost of, 1172†  
 Machine Car for Construction Work, 285\*  
 Northwest, 398†  
 Oklahoma, Prospects in, 577  
 Organization for Construction Work; C. B. & Q., 111  
 Portland, Eugene & Eastern, 453\*  
 Rome Improvements; N. Y. C. & H. R., 282\*  
 Summit-Hallstead Cut-Off, D. L. & W., 903\*, 1069\*  
 Wasatch Mountains Line; D. & R. G., 1013\*

## GENERAL INDEX—Continued.

[Illustrated articles are indicated thus\*; Editorials thus†; Letters to Editor thus‡.]

- Conventions (See names of associations)  
 Conveying Machinery (See Hoisting and Conveying)  
 Cooling (See Refrigeration)  
 Correspondence (See Organization)  
 Cost (See Finance; also Maintenance of Way; also Construction; New; also Interstate Commerce Commission)  
 Coupler (See Draft Gear)  
 Coupler Release Rigging, 1168\*  
 Crane (See Hoisting and Conveying)  
 Creosote (See Ties and Timber)  
 Crop:  
 Conditions, 68, 304, 473, 719  
 Oats Crop, 163  
 Crossing (See Grade Crossing)
- D**
- Damages (See Claims)  
 Dan Patch Lines: Gas-Electric Locomotive, 916\*  
 Delaware & Hudson: Foundry, Brass, Iron and Steel, 467\*  
 Delaware, Lackawanna & Western:  
 Concrete Buildings, 511\*  
 Engineman Schroeder Acquitted, 4†  
 Frog and Switch Shops, 975\*  
 Montclair, N. J., Station, 9\*, 54  
 Rewards for Suggestions from Employees, 1196  
 Safety Results, 387  
 Summit-Hallstead Cut-Off, 903\*, 1069\*  
 Demurrage (See Car Service)  
 Denver, Boulder & Western: Accident at Eldorado, Col., 198  
 Denver & Rio Grande:  
 Rail Section, 90-lb., 774\*  
 Telephone Train Despatching, 1085  
 Wasatch Mountains Line, 1013\*  
 Denver & Salt Lake: Moffat Tunnel Report, 1036  
 Derailments: Responsibility for Minor, 1177  
 Derrick (See Hoisting and Conveying)  
 Detroit, Toledo & Ironton: Twenty Locomotives Condemned, 628  
 Discipline (See Employee)  
 Docks (See Yards and Terminals)  
 Draft Gear:  
 Greater Strain on, 1055†  
 Standard Test for Draft Gears Recommended, 499\*  
 Drawbridge (See Bridges and Buildings)  
 Drill: Gasolene Rock Drill, 780\*  
 Drinking (See Sanitation; also Employee)  
 Duluth & Iron Range: Ore Docks at Two Harbors, Minn., 486\*
- E**
- Earnings (See also names of Companies)  
 Earnings for 1912-13, 630  
 Earnings in 1912 and 1902, 650  
 Freight Car Earnings, 646†  
 Incomes, Railway, 492  
 Interstate Commerce Commission, Revenues and Expenses for June, 392; August, 670; September, 883  
 Mail Pay; see Mail  
 Revenues and Expenses for May, 203\*;  
 June, 535\*;  
 July and August, 881\*;  
 September, 1040\*  
 Revenues and Expenses in 1912, 181  
 East Broad Top Railroad & Coal Company: Inspection Motor Car, 523\*  
 Economic Practices:  
 Boiler Tubes, Old, Used Again; Southern Pacific, 63  
 Coal Pile, Watching the, 221  
 Engine Failures, 255†  
 Fuel, Cheaper, for Pumping Engines, 277†, 289  
 Fuel Economy, 563\*, 874\*  
 Fuel Economy and the Operating Department, 332, 402†  
 Fuel Economy, St. L. & S. F., 874\*  
 Overloading Freight Locomotives not Economical, 915  
 Reclamation of Scrap Tool Steel, 158  
 Scrap Reclaiming, A. T. & S. F., 260\*, 278†, 739†  
 Education:  
 Air Brake Instruction, Western Maryland, 343  
 Apprentices, Choosing from, 2†, 7\*, 40†  
 Apprentice Instructors, N. Y. C. & H. R., Conference of, 639†  
 Apprenticeship, 151, 1023  
 College Man and the Railroads, 49, 99†, 851†  
 Educational Bureau, Chicago Transportation Association, 837  
 Educational Bureau of the Union Pacific, the Illinois Central and the Central of Georgia, 63  
 Efficiency Correspondence Schools, 807†  
 Engineering Course, Co-Operative; University of Cincinnati, 298\*  
 First Aid Instruction, 259†  
 Foremen from Clerks, 1187  
 North Western University School of Commerce, 426  
 Education (Continued):  
 Safety First Movement (See Safety First)  
 Scholarships, Southern Pacific, 878  
 Traveling Engineers, Duties of, 315†, 331  
 University of Minnesota Railway Course, 629  
 Efficiency Methods (See also Maintenance of Way; also Fuel):  
 Efficiency Correspondence Schools, 807†  
 Engine House Efficiency, 153\*  
 Human Element in Industrial Management, 135†  
 Labor Saving Appliances, Use of, 1172†  
 Men, Use of Experienced, 1172†  
 Wells, Fargo & Company Express, 160  
 Electric Carrier System, 624\*  
 Electric Storage Battery Co.; Axle Lighting System, Constant Voltage, 923\*  
 Electric Traction (See Locomotive, Electric) Electrification:  
 Chicago Terminals, 666  
 Electric Railroading, Principles of, 230\*, 418  
 London & Port Stanley to be Electrified, 834  
 Long Island Railroad, 794  
 Mountain Railway Electrification, Tehachapi Pass, Southern Pacific, 441†, 447\*  
 Norfolk & Western, 241, 387  
 Pennsylvania Railroad at Philadelphia, 577  
 Troubles with Employees on Electric Lines of S. P., 343, 357, 387  
 El Paso & South Western: Economical Bridge Erection, 1193\*  
 Embankment (See Maintenance of Way)  
 Employee (See also Legislation; also Education; also Officers; also Interstate Commerce Commission Rulings; also Legal Decisions; also Accident):  
 Accidents and Employees, 482†, 743†  
 Apprentice (See Education)  
 Bridge Foremen, Don'ts for, 981  
 Contracting of Maintenance Work, 503†, 516  
 Contracts, Bangor & Aroostook, 240  
 Compensation Legislation, 1180  
 Co-operation of Pullman Employees, 1154†  
 Courtesy on the Intercolonial, 441†  
 Discipline and the Brotherhoods, 316†  
 Discipline Made Just, 1109†  
 Discipline, Weak Spots in, 550†  
 Discipline Without Suspension, 530  
 Discourtesies, College Man to Detect, 1†, 84†  
 Drinking and Safety, 529  
 Drinking, Prosecutions for, 714  
 Electric Operation, Demands for Regular Wages with, on S. P. Lines, 343, 357, 387  
 Engineman Doherty Released, 240  
 Engineman Rewarded for Capturing Robber, 343  
 Engineman Schroeder Acquitted, 4†  
 Engineman's Tombstone, 6†, 83†, 768  
 Enginemen and Accidents, 743†  
 Enginemen and Surprise Tests, 851†  
 Enginemen Annoyed by Automobile Lights, 1210†  
 Enginemen: Keeping a Perfect Lookout, 257†, 898†, 901, 1006†, 1009, 1155  
 Enginemen, Making of, 44†  
 Enginemen, Remarkable Records, 927  
 Enginemen's and Firemen's Conventions, 133†  
 First Aid Instruction, 259†  
 Foreman Problem, 526, 1171†, 1187  
 Government Ownership and the Railway Employee, 1165  
 Homes, Distant, 602†, 942†  
 Hours of Service Law in Massachusetts, 40†, Labor and Capital, Monopolists of, 577  
 Labor Economy, 769†  
 Labor Investigation, 964  
 Labor, Maintenance, Holding, 503†, 769†, 771, 979  
 Labor, President Worthington on, 667  
 Labor Problem, Plan for Solving, 663  
 Labor, Track, Economies of, 521  
 Labor Unions Denounced, 39†, 52  
 Labor Unions, Governor Foss on, 530  
 Manslaughter, Arrests for, 198  
 Medical Inspection Bureau for Employees, 63  
 Merits and Demerits, 64, 171†, 201  
 Number of Employees in 1912, 180  
 Ordinary Comforts for Section Forces, 1192\*  
 Passes, 138†  
 Passes in Illinois, 1036  
 Passes in Missouri, 29  
 Passes on the Great Northern and Northern Pacific, 430  
 Pass Form, Rock Island Lines, 275\*  
 Patron and Employee, 1065  
 Pensions, Pennsylvania System, 344, 469  
 Pictures on Watches of Employees Forbidden, 794  
 Profit Sharing, U. S. Steel Corporation, 1036  
 Recommendation Letter Forgeries, 833  
 Relief Fund, Lehigh Valley, 628  
 Reports, Daily Time and Material, 503†, 505\*  
 Rewards for Suggestions, 1196  
 Employee (Continued):  
 Roundhouse Foreman and the Road Foreman, 44†  
 Safety First; see Safety First  
 Section Foremen from Clerks, 1187  
 Seniority or Fitness to Govern in Promotion of Enginemen and Firemen, 119, 528, 598†, 641†, 687†, 794, 834  
 Signal Maintainer, 2†  
 Sleeping on Duty, Imprisonment for, 470  
 Strike:  
 Disturbances Concerning Wages, 119  
 Northern Pacific, 198  
 Sunset Lines, 926, 942†, 959, 1085  
 Western Enginemen Threaten, 825  
 Surprise Checking, Pennsylvania Railroad, 715  
 Training, 765  
 Trainmen and Their Employers in Tennessee, 927  
 Traveling Engineers, Duties of, 315†, 331  
 Wages:  
 Brakemen and College Professors, 1037  
 Engine House Pay, 446†  
 Increased Wages as Affecting the Railway Patron, 1065  
 Legislation Affecting Wages, 871  
 Prices and Railway Rates, 899†, 919  
 Wage Increase:  
 Chicago & Alton, 1195  
 Chicago, Rock Island & Pacific, 833  
 Grand Trunk, 1085  
 Intercolonial, 301  
 Mobile & Ohio, 118  
 Philadelphia Rapid Transit, 26  
 Sumpter Valley, 1083  
 Trinity & Brazos Valley, 1036  
 Y. M. C. A. Building, Appreciation of, 834  
 Engine (See Locomotive; also Locomotive, Electric)  
 Engineering and Maintenance of Way Association (See American Railway Engineering Association)  
 England (See also subjects):  
 Accident at Liverpool, 714  
 Accident at Shepherd's Bush, 1150†  
 Accident on the Midland Railway, 428  
 Capitalization of English and American Railroads, 271  
 Commission to Study Nationalization, 1054†  
 Indicators, Train, at Charing Cross, 1122\*  
 London & Port Stanley to be Electrified, 834  
 Manslaughter, Two Months for, 834  
 Trains, American Impression of, 197  
 Equipment (See Car; also Car Service; also Locomotive; also Locomotive Performance):  
 Equipment Service in 1912, 180  
 Export of British and American Railway Equipment, 572  
 Facilities, Better, Needed, 807†  
 Freight Cars in Service, 458  
 Steel Passenger Equipment Increase, 257†, 269  
 Valuation Assignment by States, 21\*  
 Erie:  
 Accident, Construction Train, 198  
 Explosives, Shipments of, 794  
 Safety First, 388  
 Safety Record, 304  
 Excavation: Steam Shovel, Moving, with Traction Engines, 782\*  
 Exhibits (See names of associations)  
 Explosives (See American Railway Association)  
 Dangerous Cars for Explosives, 794  
 Dynamite, Buildings for, 386  
 Tunneling, Explosives for, 526  
 Exposition (See Exhibits)  
 Express (See also names of companies; also Interstate Commerce Commission Rulings):  
 California Commission Reduces Express Rates, 244  
 Express Companies as Foreign Passenger Agents, 390  
 Rate Decisions, 233, 838  
 Rate Reductions in New Mexico, 719  
 Foodstuffs, Handling, 384  
 United States Express Company Annual Report, 669  
 Experimental Railroad in Germany, 524\*
- F**
- Fairbanks Co.: Standard Track Scale of the P. & L. E., 103\*  
 Fare (See Passenger Fares)  
 Farmers' Union of Texas: Train Crew Resolutions, 343  
 Farming (See Agriculture)  
 Fast Trains and Runs: Chicago to New York, 714  
 Feet and Miles Table, 793  
 Ferry Steamer, Western Pacific, 501\*  
 Files (See Organization)  
 Finance:  
 Effect of Law Regulating Security Issues; Boston & Maine, 1150†  
 Stockholders' Association, 1237

- Finance (See also Accounting):  
 Annual Report Forms, 808†  
 Banking Influence on Railroad Management, 443†  
 Capitalization in 1912, 180  
 Consolidation of New York Central and the Lake Shore, 41†  
 Elliott, Howard, to New Haven Stockholders, 387  
 Funded Debt and Foreclosure, 39†  
 Investment Conditions, 821  
 Overcapitalization and American Railroads, 271  
 Statistics, Juggling, 853†, 1020  
 Wheatly, W. W., Address of, 397†
- Fire (See also Railway Fire Protection Association):  
 Fireproof Bridges and Fires, 769†  
 Forest Protection, 469  
 Locomotives with Fire Extinguishers, 628  
 Oil Burning Locomotives Demanded in Massachusetts, 666  
 Prevention Day on the Rock Island, 1135  
 Prevention of Fire on the Western Pacific, 578\*  
 Water, Prevention from Freezing, 926  
 Firebox (See Locomotive Firebox)
- Filing, Correspondence, Use of I. C. C. Account Numbers, 1117
- Flag (See Signaling)
- Flange (See Wheel)
- Flood (See also Maintenance of Way):  
 Damages of the March Floods, 26  
 Ohio Floods, 118, 628  
 Reconstruction; B. & O., 99†, 106\*  
 Reconstruction on the Monon, 99†, 110\*  
 Rescue of Passengers from a Flood, 345
- Forest Preservation (See Fire)
- Forestry (See Agriculture)
- Foss, Gov., and Enginemen's Strike, 530, 687†
- Foundry, Brass, Iron & Steel; Delaware & Hudson, 467\*
- France:  
 Accident at Melun, 879, 1037  
 Prices and Railway Rates, 899†, 919
- Franklin Institute: Quebec Bridge, Design of, 559
- Freight (See also State Commission Rulings; also Interstate Commerce Commission Rulings; also Car Service):  
 Containers, Unsatisfactory, 23
- Freight Claim Association:  
 Annual Meeting, 97  
 Freight Claim Blanks, 341\*
- Freight Claims (See Claims)
- Freight Rates (See also Interstate Commerce Commission Rulings; also State Commission Rulings):  
 Advanced Freight Rate Hearings, 3†, 10, 121, 203, 304, 430, 473, 739†, 899†, 919, 1025, 1053†, 1130, 1149†, 1151†, 1161\*  
 Advanced Freight Rate Hearings, Opinion of W. M. Acworth, 1137  
 Advanced Rates Needed, 140, 872  
 Armour Favors Rate Advances, 60  
 Boston Import Rates, 837  
 Cost and Efficiency, 39†, 58, 137†  
 Increased Rates on B. & M., 1201  
 Minnesota Rate Decisions, Significance of, 139†  
 Overcharges Refunded in Oklahoma, 924  
 Refunds During Rate Litigation, C. G. W., 26  
 Universal Freight Rate Base Sheet, 1234
- Freight Rate Reductions (See also Interstate Commerce Commission Rulings; also State Commission Rulings):  
 Great Northern, 837  
 Minneapolis, St. Paul & Sault Ste. Marie, 837  
 North Carolina, 930  
 Southern Pacific, 929  
 Western Roads to Oppose Rate Reductions, 200
- Freight Soliciting: Freight Solicitor's Art, 1159
- Freight Traffic (See also Traffic)
- Freight Yards (See Yards and Terminals)
- Frog (See Switch)
- Fuel (See also International Railway Fuel Association):  
 Cincinnati Smoke Inspection Bureau, 878  
 Coal Mining Adjuncts of Railroads, 656  
 Coal Pile, 221  
 Coal Sprinkler, 385\*  
 Coal Sprinkling, Safety Squirt for, 664\*  
 Coaling Stations on the Oregon Short Line, 1178\*  
 Economy, 563\*, 874\*  
 Economy and the Operating Department, 332, 402†  
 Lignite Coal Testing Plant, 1121  
 Oil on the Canadian Pacific, 386  
 Powdered Fuel for Locomotives, 1†, 13, 83†, 136†, 174†, 819  
 Pumping Engines, Cheaper Fuel for, 277†, 289  
 Smoke Abatement, 336, 762  
 Smoke Prevention and the Mechanical Stoker, 25  
 Smoke Problem in Chicago, 239  
 Smoke Problem in Pittsburgh, 714  
 Smoke Washing Plant at Englewood, 1022\*  
 Full Crew Laws (See Legislation)
- Gage: Australian Standard Gage, 40†  
 Gear: Power Reverse Gear, 713  
 General Electric Company: Articulated Electric Locomotives; N. Y. C. & H. R., 868\*  
 General Railway Signal Company: Train Dispatcher's Selector, 384  
 Germany: Experimental Railroad, 524\*  
 Glass, Frame for Carrying, 118\*  
 Government Ownership of Railways:  
 Alaska, 6†  
 Arguments Pro and Con, 1110†  
 Car Pooling, 398†  
 English Commission to Study Nationalization, 1054†  
 Freight Rates on State and Private Railways, 739†  
 Government Owned Cars, 414  
 Government Ownership the Alternative, 1037  
 Muckrakers, Agitation of, 688†  
 Probable Results, 1214†  
 Railway Employee and Government Ownership, 1165  
 Savings, Possibility of, 1020  
 Government Regulation (See also Interstate Commerce Commission; also State Commissions):  
 Aspects of Railway Regulation, 659  
 State Commission Appointments, Injudicious, 39†  
 Grade Revision (See also Construction, New):  
 Grade:  
 Louisville & Nashville Grading Work, 143\*, 225\*  
 Minimum Efficient Gradient, 55\*  
 Grade Crossings:  
 Abolition Requirements, 1109†, 1118  
 Automobiles and Grade Crossings, 64, 360,† 991  
 Grade Crossing Conferences, 666  
 Jamaica Improvements, Long Island, 183\*, 508\*  
 Long Island, 302  
 New York, New Haven & Hartford, 241, 387  
 Safety at Grade Crossings, 527  
 Grand Trunk:  
 Bridge Inspection Methods, 968†, 970\*  
 Safety First, 387, 834, 879  
 Wages of Station and Telegraph Employees Increased, 1085  
 Grand Trunk Pacific: Construction Work, 715  
 Grashof Medal Presented to George Westinghouse, 1136  
 Gravel (See Ballast)  
 Gray-Thurber Automatic Stop, 833  
 Great Britain (See England)  
 Great Northern: Triangular Ties, 782\*
- H  
 Halifax Ocean Terminals Railway, 388  
 Hamburg-American Steamship Company: Pool Agreement, Retirement from, 203  
 Hancock Inspirator Company: Coal Sprinkler, 385\*  
 Harriman Lines (See separate companies)  
 Harriman Medal Competition, 708, 1197  
 Headlight (See Lighting)  
 Hervey, D. F.: Locomotive Stoker, 385\*  
 Highway Crossing (See Grade Crossing)  
 Hine, Major, 687  
 Hocking Valley: Annual Report, 645†, 684  
 Hoisting and Conveying:  
 Crane, Compensating Quadrant, 197\*  
 Steam Shovel, Moving with Traction Engines, 782\*  
 Traveler for Dismantling a Train Shed, 115\*  
 Trucks, Electric, in Freight House Service, 236\*
- Hose:  
 Air Brake Hose, 711\*  
 Automatic Train Pipe Connector, 195\*
- Hospital:  
 Harriman Medical Research Fund, 160  
 Hospital Associations, M. K. & T., 199  
 Hospital Car, C. R. I. & P., 748\*
- Hostility (See Public, Railway's Relations with)
- I  
 Illinois & Iowa Demurrage Bureau: Cars Worth More Than Demurrage Money, 579  
 Illinois Central:  
 Annual Report, 551†, 588  
 Educational Bureau, 63  
 Park, W. L., Address of, 520  
 Pictures on Watches of Employees Forbidden, 794  
 Reports, Daily Time, 503†, 506\*  
 Safety First Meeting, 667  
 Weighing Bureau at Chicago, 527
- India:  
 Darjeeling Himalayan Railway, 327\*  
 Development of the East Indian Railway, 172†, 191  
 Kalka-Simla Railway, 657\*  
 Maintenance Work, Heavy, 989\*  
 Indicators, Switch, 1113†  
 Indicators, Train, at Charing Cross, 1122\*  
 Industrial Development by Railways (See Agriculture)
- Injunction (See Legal Decisions)  
 Inspection Car (See Motor Car)  
 Interchange (See Car Service)  
 Intercolonial:  
 Courtesy of Employees, 441†  
 Discipline Without Suspension, 530  
 Rules, Enforcing of, 714
- International Congress of Refrigeration:  
 Congress, Third, 567  
 Facilities for Replenishing Ice for Refrigeration in Transit, 568  
 Organization for Handling Refrigeration Transportation, 569  
 Pre-Cooling Perishable Goods at Loading Stations, 568
- International Railroad Master Blacksmiths' Association: Annual Convention, 357†, 369
- International Railway General Foremen's Association:  
 Annual Convention, 98, 151
- Interstate Commerce Commission (See also Interstate Commerce Commission Rulings; also Commerce Court; also Legislation; also Legal Decisions):  
 Accident Bulletin No. 46, 383; No. 47, 759  
 Accident Report, Missouri Pacific at Brant, Mo., 270  
 Accident Report, N. Y. N. H. & H. at North Haven, 461, 599†, 602†, 619  
 Accident Report; N. Y. N. H. & H. at Stamford, 79†, 82†, 94, 125, 138†  
 Accident Report, Pennsylvania Railroad at Tyrone, Pa., 494\*  
 Accounts, System of, 954  
 Account Numbers for Filing Correspondence, 1117  
 Annual Report, 1228  
 Annual Report Forms, 808†  
 Appointments, 809†  
 Brandeis, Louis D.:  
 Appointed Attorney, 687†  
 Protests Against, 1039  
 Car Shortage Circular, 798  
 Clements, Judson C., Reappointed, 1239  
 Decisions, Benefits of, 579  
 Engineer, Need for, 744†  
 Freight Rate, Advanced, Hearings (See Freight Rates; Advanced Freight Rate Hearings)  
 Freight Claim Blanks Approved, 1239  
 Hours of Service Law and Its Effect, 364†  
 Investigations, Wasting Money on, 470  
 Prouty, Commissioner, Lotos Club Address, 1149†  
 Rail, Analysis of Broken, 623  
 Revenues and Expenses for June, 392; August, 670; September, 883  
 Statistics of Railways for the Year Ended June 30, 1912, 180  
 Statistics for 1902 and 1912, 345, 650  
 St. Louis & San Francisco Investigation, 1005†, 1038  
 Telephone Companies Must Furnish Statements, 301  
 Vacancies, 1005†
- Interstate Commerce Commission Rulings (See also Commerce Court; also Legal Decisions; also Legislation):  
 Apple Rates to Little Rock, 1240  
 Automobile Rates to Portland, Ore., 1093  
 Banana Rates Reduced, 31  
 Barrel Stave Rates, 123  
 Brick Rates from Ohio Points to Huntington, W. Va., 884  
 Brick Rates to Huntington, 885  
 Broom Rate Increased, 885  
 Butter and Cheese Rates not Increased, 885  
 Butter and Egg Rates not Increased, 164  
 Car Distribution, 1092  
 Cars not Misrouted, 1043  
 Carrollton, Ga., Discriminated Against, 248  
 Cement Rates, 1042  
 Champagne Rates to California, 1092  
 Chicago-Missouri River Class Rates Unreasonable, 244  
 Chicago, Zeigler & Gulf, Joint Rate with, Canceled, 32  
 Citrus Fruit Rates Reduced, 998  
 Classification of Iron and Steel Window Frames and Sash, 1143  
 Coal Rates Discriminatory, 124  
 Coal Rates from Gallup, N. Mex., 1042  
 Coal Rates not Increased, 885  
 Coal Rates Reduced, 123, 839  
 Columbia, S. C., Discriminated Against, 998  
 Commodity and Class Rates from Pittsburgh, 125  
 Commodity Rates Between Missouri River Points, 885  
 Commodity Rates from Colorado East Reduced, 247  
 Commodity Rates Increased, 798  
 Conference Rulings, 31, 248  
 Corn Milled at Oneonta, N. Y., 31  
 Corn Rates to Wilmington, 1043  
 Corrugated Iron Ratings, 1240  
 Cotton Piece Goods Rates Reduced, 310  
 Cotton Rates from Oklahoma to New Orleans, 1092  
 Cotton Seed and Its Products, Rates on, 347  
 Cotton, Through Export Bills of Lading on, 72  
 Detroit Switching Charges, 1093



## GENERAL INDEX—Continued.

[Illustrated articles are indicated thus\*; Editorials thus†; Letters to Editor thus‡.]

## Interstate Commerce Commission Rulings (Continued):

Discrimination in Car Distribution, 1203  
 Douglas, Ga., Discriminated Against, 1043  
 Duluth Discriminated Against, 164  
 Express Rate Cases, 233  
 Express Rate Modifications, 1042  
 Fourth Section Application Granted, 349  
 Free Return of Exhibits, 1093  
 Georgia Towns Discriminated Against, 1043  
 Government Losses in Oregon Short Line Through Route Case, 1204  
 Grain Rates, 1043  
 Grain Rates from Toledo, 124  
 Grain Rates in Central Freight Association Territory, 1243  
 Grain Rates not Increased, 1043  
 Hay Rates Increased, 123  
 Interurban Electric Lines, Joint Rates Over, 164  
 Iowa Cities Case, 247  
 Iowa Rates to Utah and Colorado Reduced, 247  
 Iron and Steel Rates Reduced, 72  
 Jersey City, N. J., Discriminated Against, 72  
 Kansas-Iowa Brick Rates, 884  
 LaGrange, Ga., Discriminated Against, 245  
 Lighterage Charges, Chicago, 1043  
 Lumber and Shingles, Reconignment and Storage of, 72  
 Lumber Rates, 1044  
 Lumber Rates from Memphis and Other Points to New Orleans, 124  
 Lumber Rates not Increased, 885, 1043  
 Lumber Rates Reduced, 31  
 Lumber Rates to Memphis, Tenn., 124  
 Lumber Shipments, Reparation, 32  
 Malting in Transit, 1093  
 Manufacturers' Railway Case, 247, 306, 317†  
 Massachusetts-Maine Wool Rates, 1240  
 Meat Rates, Fresh, 1042  
 Mileage Books, 885  
 Milk Rates Reduced, 124  
 Mississippi River Case, 247  
 Missouri River-Illinois Wheat and Flour Rates, 32  
 Montezuma, Rates to, Reduced, 839  
 Nashville Coal Rates Reduced, 1243  
 New Haven Commutation Fares, 1240  
 New England Investigation, 73, 80†  
 News Print Paper Rates not Reduced, 247  
 New York Suburban Fares, 72  
 Overcharges Collected, 1043  
 Oyster Shipments from Baltimore, 431  
 Paper Rates from Manitowoc and Milwaukee to Kaukauna, Wis., 885  
 Passenger Fares, Special, Cannot be Reduced, 244  
 Petroleum Products Rates Reduced, 72  
 Pipe, Conduit, Rates, 1043  
 Port Arthur, Tex., not Discriminated Against, 73  
 Potato Rates Increased, 885  
 Rate of Twenty-three Cents on Coffee Reasonable, 1093  
 Rates from Meridian, Miss., 1092  
 Rates on Beer from Dubuque, 1092  
 Rates on Cereal from Belle Plaine, 1092  
 Rates on Coal to Milwaukee and Other Wisconsin Points, 1240  
 Refrigerating Charges not Increased, 885  
 Reparation, 998  
 St. Louis Rates Reduced, 164  
 Salt Rates from Wisconsin to Iowa, 123  
 Salt Rates not Changed, 206  
 Scrap Iron Rates, 1043  
 Sioux City not Discriminated Against, 124  
 Spoke Rates Reduced, 32  
 Springfield, Ill., Awarded 113 Per Cent. Group Rates, 1240  
 Stone, Building, Rates, 839  
 Storage Charges in Central Freight Association Territory, 998  
 Tariffs, Charges for Copies of, 172†  
 Telephone Service in Pittsburgh, Pa., 123  
 Tin Cans and Fruit Baskets, Rates on, 349  
 Tin Cans, Petroleum, and Other Commodities, 31  
 Transcontinental Rates from Group F, 206  
 Tub Rates Reduced, 431  
 Unused Transit Privileges, 1092  
 Vegetable Rates Reduced, 885  
 Vienna, Ga., Discriminated Against, 247  
 Volco, Fifth Class, 839  
 Washington, D. C., Discriminated Against, 31  
 Washington Western, Joint Rates with, 124  
 Weighing, Cane, 248  
 Weighing Charges, 1092  
 Wheat Rates from Chicago and Minneapolis, 125  
 Wheat Rates Reduced, 164  
 Investment (See Finance)  
 Iron and Steel (See also Rail; also Wheel; also Welding; also American Society for Testing Materials):  
 Ingot Iron, 112\*  
 Manganese Steel, 518  
 Manganese Steel Rails, Specifications for, 291

## K

Kansas City Southern: Case Before the Supreme Court, 1093, 1107†  
 Kansas & Southwestern:  
 Passenger Fare Increase, 206  
 Three-Cent Fare Asked, 160  
 Valuation Committee, 469  
 Kilbourne & Jacobs Manufacturing Company:  
 Dump Car, Automatic Air, —  
 Kolesch & Co.: Fulton Pocket Target, 1194\*

## L

Labor (See Employee)  
 Lake Shore & Michigan Southern:  
 Consolidation with New York Central, Proposed, 41†  
 Reclaiming Timber with a Resawing Machine, 105  
 Smoke Washing Plant at Englewood, 1022\*  
 Lamp (See Lighting)  
 Legal Decisions (See also Interstate Commerce Commission Rulings; also State Commission Rulings; also Legislation; also subjects; also Commerce Court):  
 Air Brakes in Switching, 1093  
 Brakes for New York Street Cars, 125  
 Bribery, Fine for, 886  
 Classification, False, Fine for, 839, 881  
 Compensation Fund and Damages, 165  
 Conciliation Committee Proposed, 5†  
 Damages Paid Twice, 1044  
 Defrauding Railways, Fines for, 430  
 D. L. & W. Fined for Violation of Com-mo-jitics Clause, 1093  
 False Classification of Freight, 1244  
 Freight Claim Frauds Punished, 244  
 Full Crew Laws of Pennsylvania Sustained, 33  
 Headlight Law of Illinois, Injunction Against, 33  
 Hours of Service Law Fines, 249  
 Indiana Freight Rate Reduction, 886  
 Iowa Passenger Fare Law Enjoined, 249  
 Kansas City Southern Case, 1093, 1107†  
 Lemon Rates Sustained, 886, 936  
 Lighterage in New York Harbor, 1093  
 Mileage Tickets in Georgia, 1096  
 Minnesota Rate Case, 89, 133†, 139†, 200, 430  
 Nebraska Rate Case, 808†  
 Oregon Rate Law Declared Invalid, 672  
 Overcharges Refunded in Oklahoma, 924  
 Passenger Fares in Alabama, 583  
 Passenger Fares in Pennsylvania, 582  
 Passes, Fines for Receiving, 719, 800  
 Passes in New Jersey, 886  
 Robber Sentenced, 118  
 Sleeping on Duty, Imprisonment for, 470  
 Southern Pacific Land Case, 73  
 Tap Line Order Overruled, 1096  
 Theft, Sentence for, 926  
 Weeds and Damage to Lands, 936  
 Legislation (See also Government Regulation; also Commerce Court; also Interstate Commerce Commission; also Interstate Commerce Commission Rulings; also State Commission Rulings):  
 Arbitration Law, New, 81†  
 Conciliation Committee Proposed, 5†  
 Congress and Crude Bills, 639†  
 Difficulties in Neighboring States, 2†  
 Effect of Massachusetts Law Regulating Security Issues, 1150†  
 Full Crew Law and Mr. Sulzer, 256†  
 Grade Crossing Abolition Requirements, 1109†, 1118  
 Hasty Legislation, Plea Against, 449  
 Hours of Service Law and Its Effect, 364†  
 Hours of Service Law in Massachusetts, 40†  
 Illinois Public Utilities Law, 88  
 Investigations, Wasting Money on, 470  
 Liquor, Sale of, on Ohio Trains, 714  
 Maine Railroad Laws, 61, 118  
 Operation, Legislation Relating to, 256†, 270, 277†  
 Passes in Illinois, 1036  
 Preventing Harmful Legislation, 315†  
 Public Service Law in Pennsylvania, 238, 359†, 379  
 Seamen, Number of, 991  
 Surprise Tests Abolished in Kansas, 4†  
 Train Crew Legislation, Analysis of, 750  
 Train Crew Legislation, Opposition to, 343  
 Wages, Time and Payment of, 871  
 Working Hours for Women, 343  
 Lehigh Valley:  
 Accident near Slatington, Pa., 200  
 Annual Report, 484\*†, 545  
 Bridge Inspection Methods, 968†, 969  
 Employees' Relief, 628  
 Locomotive Record, 704\*  
 Newark Bay Trestles Rebuilt in Twelve Days, 24  
 Passengers, Courtesy to, 27  
 Refrigerating Barges, 1039  
 Lignite Coal Testing Plant, 1121

Lighting (See also Association of Railway Electrical Engineers):  
 Axle Lighting System, Constant Voltage, 923\*  
 Deflectable Headlight, 645\*  
 Indirect Lighting, Unsatisfactory, 926  
 Searchlight on Observation Car, 160  
 Spheroidal Lens, Armpear, 502\*, 795  
 Link Side Bearing Co.: Link Side Bearing Truck, 1167\*  
 Liquor (See Employee; also Legislation)  
 Locomotive:  
 Axles (See Wheel)  
 Bearings (See Bearings)  
 Boiler Inspection Report of Chief Inspector, 1209†, 1233  
 Cab Window Ventilator, 1128\*  
 Diesel Locomotive, 697\*  
 Engine Failures, 255†  
 Export of British and American Locomotives, 572  
 Firing (See Fuel)  
 Fuel (See Fuel)  
 Gas-Electric, Dan Patch Lines, 916\*  
 Headlights (See Lighting)  
 Inspection Locomotive, Atlantic Type, 404\*  
 Pacific Type Locomotives, C. & O., 571\*  
 Powerful Locomotives, Northern Pacific, 377\*  
 Progress of Design in 1913, 1209†, 1215  
 Superheater Locomotives, 96  
 Tractive Effort, 455\*  
 Trucks (See Trucks)  
 Valve (See Valve)  
 Young Superheater, 1169\*  
 Locomotive Boiler (See also Master Boiler Makers' Association):  
 Circulation, 364†  
 Explosion, Southern Pacific, 159  
 Studs, Thread and Taper for Boiler, 178  
 Tube Specifications, 174†  
 Locomotive (Electric): Articulated Electric Locomotives; N. Y. C. & H. R., 868\*  
 Locomotive Firebox:  
 Brick Arch, Advantages of, 335  
 Circulation in Firebox Water Legs, 174†  
 Hervey Locomotive Stoker, 385\*  
 Life of Locomotive Fireboxes, 91\*, 364†  
 Mechanical Stokers and Smoke Prevention, 25  
 Standard Locomotive Stoker, 639†, 647\*  
 Locomotive (Freight): Northern Pacific; Powerful Locomotives, 377\*  
 Locomotive Performance:  
 Atlantic Type Locomotive Record, Pennsylvania Railroad, 470  
 Engine Failures, 255†  
 Grades and Locomotive Performance, 55\*  
 Locomotive Record, Lehigh Valley, 704\*  
 Overloading Freight Locomotives not Economical, 915  
 Tractive Effort, 455\*  
 Train of 99 Cars Hauled 111 Miles by One Locomotive, 270  
 Long Island Railroad:  
 Criticisms Invited, 670  
 Electrification, 794  
 Jamaica Improvements, 183\*, 508\*  
 Lookout, Keeping a Perfect, 898†, 901, 1006†, 1009  
 Louisville & Nashville: Improvements, 143\*, 225\*  
 Lumber (See Ties and Timber)

## M

Machine Tools:  
 Press, Hydraulic Forging and Bending, 665\*  
 Rail Anchor Testing Machine, 509\*  
 Mail:  
 Electric Carrier System, 624\*  
 Fifty Pound Parcels by Mail, 1107†  
 Jones' Mail Catcher, 758\*  
 Parcel Post and Express Business, 996  
 Parcel Post Record Shipment, 420  
 Railway Mail Pay, 200, 241, 326, 344, 794, 1107†, 1138, 1236  
 Railway Mail Service, 1239  
 Trains and Late Mails, 835  
 Twenty-Pound Parcels by Mail, 161, 344  
 Unprofitable Contract, T. St. L. & W., 241  
 Maintenance of Way (See also Rail; also Ties and Timber; also Accounting; also Hoisting and Conveying; also American Railway Engineering Association):  
 Accident Due to Defective Maintenance, 967†  
 Accidents, Methods of Reducing, 978  
 Accidents, Personal and Otherwise, Viewed from a Maintenance Standpoint, 515  
 Appliances, New, 518  
 Appliances, Power Driven and Labor Saving, 519  
 Ballast (See Ballast)  
 Ballast Car, Repairing, 990  
 Bridge Building Organization, 116  
 Bridge Inspection Methods, 968†, 969\*  
 Bridge Replacing, C. of N. J., 699\*  
 Caving Down Banks Ahead of a Steam Shovel, 510\*  
 Cinders, Valueless, 99†  
 College Man and Maintenance Work, 99†

Maintenance of Way (Continued):  
 Construction Organization, C. B. & O., 111  
 Contracting Maintenance Work, 503†, 770†, 516  
 Cost of Construction Work, 1172†  
 Derailments, Responsibility for Minor, 1176  
 Drains and Sewers, 786  
 Earthwork, Method of Handling Light, 287\*  
 Equipment, Small, and Maintenance Work, 99†  
 Fiscal Year and Maintenance Work, 100†  
 Flood (See also Flood)  
 Flood Reconstruction; B. & O., 99†, 106\*  
 Flood Reconstruction; Chic., Ind. & Louis., 99†, 110\*  
 Foundation Failure, 986\*  
 India, Heavy Maintenance Work, 989\*  
 Labor Holding, 503†, 769†, 771, 979  
 Labor Problems, Track, 769†  
 Labor, Track, Economics of, 521  
 Material, Selection of, by Men on the Ground, 1172†  
 Motor Car for Inspection Purposes, 523\*  
 Motor Cars for Maintenance of Way Forces, 100†, 101, 519  
 Organization of Maintenance Forces, Combined, 517  
 Prizes for Track Maintenance; Pennsylvania Railroad, 780  
 Rails and Fastenings, Second Hand, Handling on Branch Lines, 299  
 Raising Relocated Panama Railroad, 981  
 Reclaiming Maintenance Scrap, 260†, 278  
 Reports, Daily Time and Material, 503†, 505\*  
 Safety Suggestions, 1185  
 Section Forces, Ordinary Comforts for, 1192\*  
 Scoop Car for Removing Slides, 987\*  
 Section Car (See Motor Car)  
 Shifting a Long Section of Track, 782\*  
 Snow Fences, 790  
 Snow, Preparation for, 967†  
 Structures, Temporary, for Supporting Tracks, 787  
 Tanks, Wooden, Repaired with Concrete, 981  
 Track Inspection on the N. Y. C. & H. R., 1192  
 Tie Plates, 518  
 Track Layer, Three Men, 525\*  
 Work Trains (See Competition)  
 Year of Decided Contrast, 1171†  
 Maintenance of Way Master Painters' Association:  
 Annual Convention, 983, 1179  
 Advertising Value of Railroad Painting, 983  
 Bridge Painting Difficulties, 982  
 Bridge Paint Tests, 1179  
 Concrete Surfaces, Treatment of, 984  
 Contracting of Railroad Painting, 983  
 Paints and Oils, Safe Storage of, 1181  
 Red Lead, New Department in, 984  
 Workmen's Compensation Legislation, 1180  
 Manistique & Lake Superior: Department of Development, 715  
 Manufacturers' Railway of St. Louis: Case Before the Interstate Commerce Commission, 247, 306, 317†, 527, 633  
 Mark Manufacturing Company: Steel Unions, 98\*  
 Maschinenfabrik Buckau: Track Shifter, 294\*  
 Master Car & Locomotive Painters' Association:  
 Annual Convention, 495  
 Economy in Locomotive Painting, 496  
 Enamelled Interior Trimmings, 498  
 Maintenance of Passenger Cars, 498  
 Paint Protection for Steel Equipment, 497  
 Paint Shop Supplies, 498  
 Rust Inhibitive Paint, 496  
 Steel Passenger Cars, Finishing, 495  
 Test Committee's Report, 495  
 McCord & Company: Steel Journal Box, 966\*  
 Mellen, Charles S.:  
 Dinner of B. & M. Employees, 1088  
 Position, 65  
 Responsibility for the New Haven's Troubles, 1151†  
 Resignation, 133†  
 Retained in Advisory Capacity, 426  
 Statement, 918  
 Merchants' Association of New York: Benefits of Interstate Commerce Commission's Decisions, 579  
 Mexico: Wartime Railroad, 702  
 Mileage:  
 Statistics for 1912, 180  
 Longest Railways in the World in 1864, 172†  
 Minneapolis, St. Paul & Sault Ste. Marie:  
 Annual Report, 812†, 849  
 Chicago Freight Terminal, 321\*  
 Minneapolis, St. Paul, Rochester & Dubuque Electric Traction: Gas-Electric Locomotive, 916\*  
 Missouri, Kansas & Texas:  
 Annual Report, 1057†, 1104  
 Burning Earth for Ballast, 343  
 Construction Work Stopped, 240  
 Deflectable Headlight, 645†\*  
 Hospital Associations, 199  
 Locomotives with Fire Extinguishers, 628  
 Train Auditors, 1137  
 Missionary's View of Railroads, 855†  
 Missouri Pacific:  
 Accident at Brant, Mo., 270  
 Annual Report, 689†, 737  
 Bridge Inspection Methods, 968†, 972

Missouri Pacific (Continued):  
 Kaw River Bridge Reconstruction, 45\*  
 Valuation Committees, 879  
 Mobile & Ohio: Accident at State Line, Miss., 795  
 Moment of Inertia, Finding, 381\*, 413  
 Motor Car:  
 Electric Trucks in Freight House Service, 236\*, 1153\*  
 Inspection Motor Car, Narrow Gage, 523\*  
 Motor Cars for Bridge Gangs, 786  
 Motor Cars for Maintenance of Way Forces, 100†, 101, 519  
 Motor Car Troubles, Their Symptoms, Causes and Remedies, 298  
 Mudge & Company: Inspection Motor Car, Narrow Gage, 523\*

N

National Association of Railway Commissioners:  
 Annual Convention, 807†, 831, 869  
 Safety Report, 925  
 Valuation Committees Appointed, 1085  
 National Civic Federation: Social Progress Investigation, 964  
 National Industrial Traffic League: Annual Meeting, 962  
 National Railway Appliances Association (See American Railway Engineering Association)  
 National Railway Devices Co.: Coupler Release Rigging, 1168\*  
 National Railways of Mexico:  
 Annual Report, 1211†\*  
 High Cantilever Bridge Across Rio Chico, 1222\*  
 National Transcontinental Railway: Construction Cost, 992  
 Newspapers and the Railways, 1154†  
 New York Central & Hudson River:  
 Annual Track Inspection, 1192  
 Apprentice Instructors, Conference of, 639†  
 Bridge Inspection Methods, 968†, 971  
 Electric Locomotive, Articulated, 868\*  
 Lake Shore & Michigan Southern Consolidation, Proposed, 41†  
 New York, West Shore & Buffalo Anniversary, 119  
 Reports, Daily Time and Material, 503†, 505\*  
 Rome, N. Y., Improvements, 282\*  
 Safety Exhibit Car, 213†, 228\*  
 Safety First Meeting, 1085  
 Trespassers, 255†, 267\*, 575, 640†  
 New York, New Haven & Hartford:  
 Accident at North Haven, 397†, 427, 441†, 442†, 461, 471, 482†, 575, 577, 599†, 602†, 619, 622, 628, 630  
 Accident at Stamford, 79†, 82†, 94, 125, 138†, 161  
 Accidents, Train and Automobile, 27  
 Annual Report, 944†  
 Automatic Stop Prize, 64  
 Beautifying the Line, 161  
 Boston & Providence, Life on, 426  
 Car Floats, Steel, 533  
 Causes of the Troubles, 1151†  
 Dividend Passed, 1138  
 Doherty, Engineman, Released, 240  
 Elliott, Howard, and New England, 615  
 Elliott, Howard, Outline of Plans, 471  
 Elliott, Howard, to New Haven Stockholders, 387  
 Enginemen and Firemen, Selection of, 119, 528, 598†, 641†, 687†, 794, 834  
 Fish Wharf at South Boston, 575  
 Grade Crossing Abolition, 241, 387  
 Hadley, Dr. A. T., Elected a Director, 549†  
 Interstate Commerce Commission Report on the New England Situation, 72, 80†  
 Managers, Character of, Past and Present, 258†  
 Mellen, C. S., Dinner of B. & M. Employees, 1088  
 Mellen, C. S., Position of, 65  
 Mellen, C. S., Resignation, 133†  
 Mellen, C. S., Responsibility for the New Haven's Troubles, 1151†  
 Mellen, C. S., Retained in Advisory Capacity, 426  
 Mellen, C. S., Statement of, 918  
 Morgan, J. P., & Co., Relations with, 443†  
 Rhode Island, Interests in, 879  
 Salutatory of Officers, 565  
 Slower Trains, 666  
 Summer Passenger Business, 160  
 Superheaters for Locomotives, 161  
 Ties Laid in 1913, 343  
 Traffic at South Station, Boston, 576  
 Westerly, R. I., Station, 301  
 New York Railroad Club: Future of, 1007†  
 New York Subway (See Subway)  
 Norfolk & Western:  
 Bridge at Kenova, W. Va., 400†, 407\*  
 Electrification, 241, 387  
 Scoop Car for Removing Slides, 987\*  
 Northern Pacific:  
 Abandons Form 31, 1054†  
 Angle Iron Clips for Bridge Stringers, 781\*  
 Locomotives, Powerful, 377\*  
 Safety First, 1196  
 Tipping Prohibited, 807†, 834  
 North Western University School of Commerce, 426  
 Nut, Absolute Lock, 1194

O

Officer (See also Education; also Organization; also Public, the Railway's Relation with; also Employee):  
 Accidents and Officers, 482†, 743†  
 Character of Managers, Past and Present, 258†  
 College Man and the Railroads, 49, 99†, 851†  
 Co-operation Between Railroads, Needed, 856  
 Salutatory of Officers, N. Y. N. H. & H., 565  
 Train Despatcher and the Block System, 258†  
 Ohio Storm, 993  
 Oil (See Fuel; also Lubrication)  
 Operating Efficiency:  
 Co-operation Between Railroads, Needed, 856  
 Day's Train Record Over Tehachapi Mountain, 155\*  
 Gettysburg Anniversary Traffic, 214†, 223\*, 343  
 Freight Car Loading, Increasing, 810†, 830  
 Freight Car Movement, Increasing, 175, 363†, 371, 399†, 403, 549†, 555, 579, 597†, 602†, 646, 992  
 Train Operation Sixty Years Ago, 339\*  
 Operating Studies:  
 Chesapeake & Ohio, 1053†, 1061\*  
 Chicago, Burlington & Quincy, 85\*  
 Oregon-Washington Railroad & Navigation Company:  
 Accident Due to Defective Maintenance, 967†  
 Terminal at Spokane, Wash., 817\*  
 Orenstein-Arthur Koppel Company: Quarry Car, 510\*  
 Oregon Short Line: New Coaling Stations, 1178\*  
 Organization (See also Officers; also Maintenance of Way):  
 Bridge Building Organization, 116  
 Conciliation Committee Proposed, 5†  
 Construction Organization; C. B. & O., 111  
 Divisional, Discontinued on Big Four, 1135  
 Efficient Organization Suggestions, 216†\*  
 Engine House, 153\*  
 Hine System, Office Building for, 827\*  
 Refrigeration Organization, 569  
 Reports, Daily Time and Material, 503†, 505\*  
 Station Work, 52  
 Ownership (See Finance; also Government Ownership)  
 Pacific Electric Railway: Accident near Los Angeles, Cal., 119  
 Pacific Fruit Express: Ice Manufacturing Plant, 63  
 Paint (See also Maintenance of Way Master Painters' Association; also Master Car and Locomotive Painters' Association):  
 Bridge Paint Tests, 1179  
 Fire Resisting Paint Tests, 293\*  
 Safe Storage of Oils and Paints, 1181  
 Whitewashing Device with Portable Compressor, 292\*  
 Panama Canal (See Waterways)  
 Panama, Isthmus of, Traffic over, 30  
 Panama-Pacific Exposition Railway, 794  
 Panama Railroad:  
 Accident at Paraiso, 926  
 Raising Relocated Road, 981  
 Alabama, 473  
 Cost and Efficiency, 39†, 58, 137†  
 Increased Passenger Fares Asked for by Passengers, 160  
 Iowa Passenger Fare Law Enjoined, 249  
 Minnesota Rate Decision and Passenger Fares, 68, 133†  
 Regulation of Passenger Fares, 1220  
 Two-Cent Fares and Mileage Books, 121  
 Two-Cent Fares in Missouri, 68  
 Two-Cent Fares in Oklahoma, 68  
 Passenger Fare Increase:  
 Chicago Great Western, 203  
 Kansas & Southwestern, 206  
 Passenger Fare Reduction (See also Interstate Commerce Commission Rulings; also State Commission Rulings):  
 Alabama, 669  
 Chesapeake & Ohio, 243, 473  
 Chicago Great Western, 243\*  
 Dakota, 797  
 Louisville & Nashville, 304  
 Maine Central, 390  
 Missouri, 536  
 Rates for Mileage, 1210†  
 Regulation, 1220  
 Southern Pacific, 717  
 Wichita Falls & Northwestern, 672  
 Passenger Service:  
 Dining Car Service, Canadian Pacific, 470  
 English Trains, American Impression of, 197  
 Fast Passenger Service, 214†  
 Gettysburg Anniversary Traffic, 214†, 223\*

## GENERAL INDEX—Continued.

[Illustrated articles are indicated thus\*; Editorials thus†; Letters to Editor thus‡.]

- Passenger Service (Continued):**  
 Silence for Sleepers, 358†  
 Tipping Prohibited, 807†, 834  
 Tourist Sleeping Cars, 430
- Passes (See also Legislation; also Interstate Commerce Commission Rulings; also Employee):**  
 Legislative Retaliation Threatened; C. B. & O., 1053†, 1087  
 Railroad Men in the North Carolina Legislature, 667
- Pay (See Employee)**
- Pennsylvania Railroad:**  
 Accident Committees, 714  
 Accident at Tyrone, Pa., 201, 494\*  
 Accident near Wileys, Ohio, 575  
 Accident Record, 26  
 Agricultural Demonstration Train, 1140  
 Atlantic Type Locomotive, Record of, 470  
 Bridge Inspection Methods, 968†, 973  
 Business Cars, 628  
 Dairy, Model, 342\*  
 Dynamite, Buildings for, 386  
 Electrification at Philadelphia, 577  
 Employees' Homes, 942†  
 Equipment not to be Burned After Accident, 714  
 Firemen and Enginemen, Rules for Promotion of, 528  
 Free Delivery in Washington and Baltimore Abolished, 163  
 Lunch Counter Car, 1086  
 Merits and Demerits for Employees, 171†, 201  
 Newark Bay Trestles Rebuilt in Twelve Days, 24  
 Pensions, 344, 469  
 Prizes for Track Maintenance, 780  
 Recommendation Letter Forgeries, 833  
 Rescue of Passengers from a Flood, 345  
 Safety at Grade Crossings, 527  
 Safety First, 343, 879  
 Safety First Exhibition, 614  
 Schuylkill River Bridge Improvements, 1173\*  
 Signaling Conditions, 625  
 Surprise Checking, 715  
 Ticket Abuses, 881  
 Ticket Redemption, 304  
 Traffic over the Middle Division, 68  
 Valuation Committee, 27
- Pension (See Employee)**
- Philadelphia & Reading:**  
 Gettysburg Anniversary Traffic, 214†, 223\*  
 Inspection Locomotive, Atlantic Type, 404\*
- Pittsburgh & Lake Erie: Standard Track Scale, 103\***
- Pneumatic Tools (See Machine Tools)**
- Portland, Eugene & Eastern: Construction, 453\***
- Power Specialty Co.: Young Locomotive Superheater, 1169\***
- Prussian-Hessian State Railways:**  
 Diesel Locomotive, 697\*  
 Congestion in 1912, 1209†, 1232
- Public, The Railways' Relations with (See also Finance):**  
 Advertising, Texas Railways Criticised for, 171†  
 Character of Managers, Past and Present, 258†  
 Cox, Governor James, Railway Business Association Address, 1115  
 Criticisms, 363†  
 Criticisms Invited, 670  
 Discourtesies, College Man to Detect, 1†, 84†  
 Elliott, Howard, Railway Business Association Address, 1115  
 Employee and the Railway Patron, 1065  
 Good Service, Recognition of, 214  
 Legislative Retaliation Threatened for Refusal to Issue Passes, 1053†, 1087  
 Low, Seth, on the Railroad Problem, 1197  
 Magazines and Government Ownership, 688†  
 Newspapers and the Railways, 1154†  
 New York, New Haven & Hartford Troubles, 1151†  
 Passengers, Courtesy to, 27  
 Publicity Departments, 90  
 Publicity to Accidents and Delays, 740†  
 Railroad Aided by People, 160, 206  
 Railways' Interest in Better Farming, 1006†  
 Regulation of Passenger Fares, 1220  
 Shippers, Treatment of, 345  
 Situation, The Railway, 767  
 Telephones in Ticket Offices, 214†, 325  
 Van Horne's, Sir William, Views, 1086
- Publicity Departments, 90**
- Pullman Company:**  
 Advance Reservations, 203  
 Can Pullman Employees Co-operate to Improve the Service? 1154†  
 Erd Construction for Pullman Cars, New, 231\*  
 Low Berth Rates, 632
- Pump (See Water Service)**
- Purchases, Railway, and General Prosperity, 1149†, 1161\***
- Queen & Crescent:**  
 Automatic Train Pipe Connector, 195\*  
 Rail Anchor Testing Machine, 509\*
- R**
- Rail (See Maintenance of Way):**  
 Anchor Testing Machine, 509\*  
 Branding and Heat Number Stamping of Steel Rails, 1189\*  
 Broken Rail, Analysis of, 623  
 Canadian Rail Production in 1912, 388  
 Cutting, Economy in, 1191  
 Manganese Steel Rails, Specifications for, 291  
 Ninety-Pound Rail, Denver & Rio Grande, 774\*  
 Second Hand Rails, Handling, 299  
 Statistics of Failed Rails, 529  
 Seams, 1082  
 Taper Rail, 1194\*  
 Three Man Track Layer, 525\*  
 Transverse Fissures Due to Overloading, 1108†  
 Transverse Fissures Studied by New York Public Service Commission, 1182
- Railway Business Association:**  
 Annual Meeting, 1115  
 Railway Buying and General Prosperity, 1149†, 1161\*  
 Railway Incomes, 492  
 Railway Buying and General Prosperity, 1149†, 1161\*  
 Railway Club of Pittsburgh: Air Brakes and Modern Conditions, 415  
 Railway Commissions (See State Commissions)  
 Railway Electrical Engineers' Association: Annual Convention, 831  
 Railway Fire Protection Association: Convention, 705  
 Railway Signal Association:  
 Annual Meeting, 742†, 760  
 Treated Ties and Track Circuits, 780  
 Railroad Smoke Inspectors' Association of Chicago: Smoke Problem in Chicago, 239  
 Rebates (See Legal Decisions)  
 Refrigeration (See also International Congress of Refrigeration):  
 Barges, Refrigeration, 1039  
 Reinforced Concrete (See Concrete)  
 Reports, Annual (See names of companies)  
 Rice Gasoline Rock Drill Company: Gasolene Rock Drill, 780\*
- River (See Waterways)**
- Road Building (See Agriculture)**
- Roadbed (See Maintenance of Way)**
- Roadmasters' and Maintenance of Way Association:**  
 Accidents, Personal and Otherwise Viewed from a Maintenance Standpoint, 515  
 Annual Convention, 277†, 503†, 515  
 Appliances, New, 518  
 Contracting Maintenance Work, 503†, 516, 770†  
 Economics of Track Labor, 521  
 Organization of Maintenance Forced, Combined, 517  
 Park, W. L., Address of, 503†, 520  
 Power Driven and Labor Saving Appliances, 519  
 Track Supply Association, 523  
 Robber (See Train Robberies)
- Rochester & Eastern: Accident at Victor, N. Y., 198**
- Rock Island Lines: Pass Form, New, 275\***
- Rosenbaum E. Raven: Welding and Cutting with Oxygen and Illuminating Gas, 196\***
- Rumsey Car Door & Equipment Company: Mail Car Door, 240\***
- Rules: Is Standard Code Rule 20 Safe? 1114†**
- S**
- Safeguards (See Safety Appliances)**
- Safety (See Accident; also Maintenance of Way; also Safety First)**
- Safety Appliances:**  
 Automatic Stops (See Signaling)  
 U. S. Safety Appliances Required in Canada, 119
- Safety Committees (See Accident; also Safety First)**
- Safety First (See also Accident)**  
 B. & O. Safety First Clock, 576  
 B. & O. Safety Work, 301  
 Chicago & North Western Safety First Results, 160, 922  
 Convention at Chicago, 564  
 D. L. & W. Safety Results, 387  
 Demands More Than Words, 1111†  
 Erie, Safety First, 388  
 Erie Safety Record, 304  
 Expression, Modes of, 1150†  
 Grand Trunk Safety First Campaign, 387, 834, 879  
 Harriman Medal Competition, 708  
 Harriman Safety Medal Presented to Southern Pacific, 1197
- Safety First (Continued):**  
 Illinois Central Safety First Meeting, 667  
 National Association of Railway Commissioners, Safety Report, 925  
 N. Y. C. & H. R. Safety Exhibit Car, 213†, 228\*  
 N. Y. C. & H. R. Safety Meeting, 1085  
 Northern Pacific, 1196  
 Origin of Safety Movement, 743†  
 Pennsylvania Railroad, Safety Campaign, 343, 879, 1086, 1196  
 Pennsylvania Railroad Safety First Exhibition, 614  
 Railway Clubs and Safety First, 529  
 St. L. & S. F. Safety First Swimming Pool, 470\*  
 St. L. & S. F. Safety Record, 749  
 St. L. & S. F. Safety Work, 201, 301  
 San Pedro, Los Angeles & Salt Lake Safety Efficiency Committee, 878  
 Southern Pacific, Safety First Campaign, 576  
 Western Maryland Safety First, 965
- St. Louis & San Francisco:**  
 Convertible Stock and Box Car, 1126\*  
 Farm Marketing to Be Developed, 1140  
 Fuel Economy, 874\*  
 Passenger Train Service Reduction, 243  
 President Winchell's Farewell, 160  
 Proper Loading of Coal Cars, 1083\*  
 Receivership Investigation, 1005†, 1038  
 Safety Record, 749  
 Safety First Swimming Pool, 470\*  
 Safety First Work, 201, 301  
 Statement of B. F. Yoakum, 1197, 1210†  
 Steel Frame Box Cars, 598†, 609\*
- St. Louis Southwestern:**  
 Annual Report, 641†, 685  
 Freight Terminal at St. Louis, 218\*
- Safety (See Officer)**
- Sanitation:**  
 Drinking Water, 834  
 Drinking Water, Pure; Southern Pacific, 820  
 Governmental Sanitary Inspection, 344  
 San Pedro, Los Angeles & Salt Lake: Safety and Efficiency Committee, 878
- Scale:**  
 Scale Shops, 300  
 Scale Test Car, U. S. Bureau of Standards, 114, 985\*  
 Standard Track Scale of the P. & L. E., 103\*
- Schedule: Make Up Time, 1035\***
- School (See Education)**
- Scientific Management (See Efficiency Methods)**
- Screw Spikes (See Maintenance of Way)**
- Seaboard Air Line: Annual Report, 1056\*†, 1102**
- Section Car (See Motor Car)**
- See America First, 1040**
- Sellers, Wm., & Company: Safety Squirt for Sprinkling Coal, 664\***
- Shippers (See Car Service; also Public, Railways' Relations with)**
- Shops (See also Efficiency Methods):**  
 Engine Terminals, Western Maryland, 189\*  
 Engine House Pay, 446†  
 Foundry, Brass, Iron and Steel, 467\*  
 Frog and Switch Shops, D. L. & W., 975\*  
 Inefficiency of Railroad Shops, 740†  
 Sacramento Shops, Western Pacific, 564\*  
 Scale Shops, 300  
 Scrap Reclaiming, A. T. & S. F., 260\*, 278†, 739†  
 Shop Output, 1005†, 1018
- Signal Accessories (Company: Triplelock Switch Machine, 781\*)**
- Signal, Block (See also Railway Signal Association):**  
 Automatic Block Signal Details, 760  
 Automatic Block Signal Records, Reliability of, 6†  
 Manual Block Signaling, Estimates of Costs, 761  
 Overlap, 1060†  
 Records, Reliability of, 6†  
 Train Dispatcher and the Block System, 258†  
 Space Interval System and Inadequate Signals, 1734\*
- Signaling (See also Railway Signal Association; also American Railway Engineering Association):**  
 Accident at Shepherd's Bush, 1150†  
 Adjunctive Safeguards, 689†  
 Automatic Stops and Audible Signals, 663  
 Automatic Train Stop, "Railophone," 1085  
 Automatic Train Stop, Gray-Thurber, 833  
 Automobile Accidents and White Flags, 576  
 Automatic Stop Prize; N. Y. N. H. & H., 64  
 Boston & Maine Recommended to Abolish Ball Signals, 1108†  
 Disk Signals, Enclosed, 397†  
 Enginemen Annoyed by Automobile Lights, 1210  
 Flagging Rule and Its Enforcement, 695  
 Gettysburg Signal Installation, 223\*  
 Interlocking Signals in Illinois and Wisconsin, 1037  
 Instruction on C. & N. W., 1236  
 Maintainer, Signal, 2†

**Signaling (Continued):**

Signaling Conditions on the Pennsylvania, 625  
 Space Interval System and Inadequate Signals, 173†\*  
 Stamford Collision and Signals, 79†, 82†, 94, 125, 138†  
 Surprise Tests Abolished in Kansas, 4†  
 Switch Indicators, 742†, 761, 1113†  
 Treated Ties and Track Circuits, 780  
 Smoke Prevention (See Fuel)  
 Snow (See Maintenance of Way)  
 Society for the Promotion of Engineering Education: College Man and the Railroads, 49, 99†  
 Society of Railway Financial Officers:  
 Annual Meeting, 605  
 Aspects of Railway Regulation, 659  
 Cash Book Systems, 606  
 Clearing House Settlements, 605  
 Drafts, Payment of, 605  
 Pay Laws, Semi-Monthly, 606  
 Security Market Conditions, 607  
 Vouchers, Forms of, 605  
 Southern New England (See Grand Trunk)  
 Southern Pacific:  
 Automobile Accidents at Railroad Crossings, 64  
 Boiler Explosion, 159  
 Boiler Tubes, Old, Used Again, 63  
 Bridge Inspection Methods, 968†, 973  
 Car Distribution Rules, 1086  
 Dining Car Service, 1036  
 Dissolution Plan Approved, 12  
 Drinking Water, 820  
 Harriman Medical Research Fund, 160  
 Land Forfeits, 73  
 Providing Ordinary Comforts for the Section Foreman, 1192\*  
 Receives Harriman Safety Medal, 1197  
 Safety First Campaign, 576  
 Scholarships, 878  
 Strike on Sunset Lines, 926, 942†, 959, 1085  
 Tehachapi Mountain, Day's Train Record Over, 155\*  
 Tehachapi Pass Electrification, 441†, 447\*  
 Telegraphers, Agreement with, 527  
 Troubles with Employees on Electric Lines, 343, 357, 387  
 Southern Railway:  
 Annual Report, 692\*†, 729  
 Boll Weevil, War Against, 142  
 Speed: Speed Diagram, 1035\*  
 Spike (See Maintenance of Way)  
 Standard Steel Works Company: Drop Test of Heat Treated Chrome Vanadium Wheels, 573\*  
 Standard Stoker Company: Standard Locomotive Stoker, 639†, 647\*  
 State Commissions (See also State Commissions' Rulings):  
 Advertising, Texas Railways Criticised for, 171†  
 Alabama: Platform of a Commissioner, 629  
 Appointments, Injudicious, 39†  
 Canada (See Canada)  
 Connecticut: Accident Report, N. Y. N. H. & H. at North Haven, 577, 622  
 Connecticut: Accident Report, Stamford Collision, 125  
 Grade Crossing Abolition Requirements, 1109†, 1118  
 Illinois Public Utilities Commission, 33, 88  
 Illinois: Rules, General Revision of, 206  
 Indiana: Block Signal Investigation, 475  
 Maine: Public Utilities Act, Date of Decision of, 310  
 Maine Public Utilities Commission Proposed, 61, 118  
 Massachusetts: Signaling on the Boston & Maine, 1044  
 Massachusetts: Personnel of Commission, 125  
 Minnesota: New Tariffs, 886  
 Missouri: Cost of Litigation, 163  
 Missouri: Personnel of Commission, 392  
 Money Needed for Litigation, 206  
 Nebraska: E. C. Hurd Resigned, 1093  
 New Mexico: Express Rate Reductions, 719  
 New York: Authority of Stages, 125  
 New York: Personnel of Commission, 125  
 New York Public Service Commission Studying Transverse Fissures in Rails, 1182  
 North Carolina: Rate Commission, 1039  
 Pennsylvania: New Appointments, 310  
 Pennsylvania: Public Service Commission Created, 238, 359†, 379  
 Screen Regulation Difficulties, 2†  
 Valuation, Aid in, 26  
 Wisconsin: Interlocking Plants, 800  
 State Commission Rulings:  
 Alabama: Passenger Fares, 349  
 California: Authority over Steamships, 125  
 California: Drinking Cups, 839  
 California: Express Rates Reduced, 244  
 California: Weight Basis, 672  
 California: Rates on Sierra R. R., 1244  
 Canada (See Canada)  
 Illinois: Long and Short Haul Ruling, 73  
 Illinois: Switching Rates, 672  
 Kansas: Kansas & Southwestern Passenger Fare Increase, 206  
 Kansas: Surprise Tests Abolished, 4†

**State Commission Rulings (Continued):**

Louisiana:  
 Block Signaling Ordered, 1143  
 Flagging Rule Fines, 1000  
 Script Substituted for Mileage, 1204  
 Uniform Class Mileage Rates, 1143  
 Massachusetts: Interlocking Signals on B. & M., 1108†  
 Mississippi: Syrup Rates Reduced, 1204  
 Missouri: Cash Fares, 536  
 Missouri: Passes, 29  
 Missouri: Two-Cent Passenger Fares, 125  
 Missouri: Valuation Reports Required, 886  
 Nebraska: Apple Rates Reduced, 633  
 New Jersey: Bond Sales Restrictions, 839  
 New Jersey: Drinking Water on Trains, 349  
 New Jersey: Freight Rate Increase Forbidden, 392  
 New Jersey: Lehigh Valley, 672  
 New York: Passenger Fare Reduced, N. Y. C. & H. R., 1000  
 New York: Wooden Cars on the Long Island, 1000  
 Ohio: Train Speed Limited, 998  
 Oklahoma: Ticket Windows, Time for Opening, 672  
 Oklahoma: Two-Cent Fare for the Wichita Falls & Northwestern, 672  
 Oklahoma, St. Louis & San Francisco Recommended to Improve Its Lines, 1093  
 South Dakota: Through Rates, 672  
 Wisconsin: Express Rates, 839  
 State Ownership (See Government Ownership)  
 Stake Pocket, Collapsible, 1169\*  
 Station (See also Yards and Terminals):  
 Chicago (See Chicago, Development of Railway Facilities)  
 Dead Line for Station Platform, 426\*  
 Jamaica, L. I., Long Island Railroad, 183\*, 508\*  
 Jersey City Passenger Station Reconstruction; C. of N. J., 115\*  
 Montclair, N. J., Station, 9\*, 54  
 Oregon-Washington Railroad & Navigation Company, at Spokane, 817  
 Organization, 52  
 Platform Tickets, 161  
 Traffic at South Station, Boston, 576  
 Westerly, R. I.; N. Y. N. H. & H., 301  
 Statistics (See also Earnings):  
 Interstate Commerce Commission Figures for 1902 and 1912, 650  
 Juggling Railway Statistics, 853†, 1020  
 Railway Results in 1912 Compared with 1902, 345  
 Statistical Information Practices, 213†  
 Statistics of Railways for the Year Ended June 30, 1912, 180  
 Staybolt (See Locomotive)  
 Stock (See Finance)  
 Stoker (See Locomotive)  
 Stokers, Mechanical (See Locomotive)  
 Stop, Automatic Train (See Signaling)  
 Street Railways (See Electric Railways)  
 Strike (See Employee)  
 Subways: New York, 241, 715  
 Sulzer Bros.: Diesel Locomotive, 697\*  
 Sulzer, William. Impeachment of, 256†  
 Superheater:  
 Handling Superheater Locomotives, 334  
 Superheater Locomotives, 96  
 Superheater for New Haven Locomotives, 161  
 Young, Locomotive, 1169\*  
 Supply Department (See also Railway Storekeepers' Association):  
 Railway Supply Department, 857  
 Surveying: Simple Method of Obtaining Time and Azimuth, 1186\*  
 Surety Company Methods, 531  
 Switch:  
 Frog Angles, Methods of Calculating, 293\*, 504†\*, 774  
 Switch Stands, 519  
 Triplelock Switch Machine, 781\*  
**T**  
 Table: Feet and Miles Table, 793  
 Tariff:  
 Charges for Copies of Tariffs, 172†  
 Minnesota Tariffs, New, 886  
 Simplification of, Movement for, 816  
 Target, The Fulton Pocket, 1194\*  
 Telegraph (See also Association of Railway Telegraph Superintendents):  
 Poles, Reinforced Concrete, 286  
 Wireless Telegraph Extensions, 667  
 Wireless to Trains, 1036  
 Telephone:  
 Don'ts for Operators and Others on Railroad Telephone Lines, 64  
 Interstate Commerce Commission Investigation, 301  
 Selector System, 384  
 Telephones in Ticket Offices, 214†, 325  
 Terminal (See Yards and Terminals)  
 Terminal Railroad Association of St. Louis: Reorganization Plan, Proposed, 249  
 Traffic Increase, 1039  
 Texas: Railways Needed, 927  
 Theft (See Train Robberies)  
 Ticket:  
 Abuses on the Pennsylvania Railroad, 881  
 Redemption on the Pennsylvania, 304  
 Ticket Agents' Contest; B. & O., 714, 966

Ties and Timber (See also American Wood Preservers' Association; also Maintenance of Way):  
 Concrete Ties, Design of, 259†  
 Device for Loading, 1181\*  
 Douglas Fir Car Material, Specifications and Rules for, 557  
 Preservation of Timber, 791  
 Reclaiming Timber with a Resawing Machine, 105  
 Tie Supply and Cost, 99†  
 Ties Laid by the N. Y. N. H. & H., 343  
 Treated Ties and Track Circuits, 780  
 Timber Preservation (See Ties and Timber)  
 Time and Azimuth, Simple Method of Obtaining, 1186\*  
 Tire (See Wheel)  
 Toledo, St. Louis & Western: Mail Contract, Unprofitable, 241  
 Tool (See Machine Tools)  
 Track (See also Maintenance of Way; also Construction, New):  
 Foundations, Concrete, for Heavy Service Tracks, 508\*  
 Frog Angles, Methods of Calculating, 293\*, 504†\*, 774  
 Shifter, Track, 294\*  
 Shifting a Long Section of Track, 782\*  
 Tests of Track Devices, 277†, 279\*  
 Track Layer, Three Men, 525\*  
 Track Supply Association (See Roadmasters' and Maintenance of Way Association)  
 Trade Unions (See Employee)  
 Traffic Club of Chicago: Railway Employee and the Railway Patron, 1065  
 Train Dispatchers' Association of America: Annual Convention, 15  
 Train Despatching:  
 Block System and the Train Despatcher, 258  
 Form 19 Exclusively, 1136  
 Is Standard Code Rule 20 Safe? 1114†  
 Northern Pacific Abandons Form 31, 1054†  
 Telephone, 63, 343, 469, 1085  
 Telephone Selector System, 384  
 Train Operation Sixty Years Ago, 339\*  
 Train Lighting (See Lighting)  
 Train Resistance: Freight Train and Canal Boat Resistance, 958\*  
 Train Robberies, 63, 240, 343, 527, 628, 991  
 Train Rules (See also American Association of Railroad Superintendents):  
 Train Operation Sixty Years Ago, 339\*  
 Train Stop, Automatic (See Signaling)  
 Trainmen (See Employee)  
 Tramp Problem, 213†, 629  
 Transformer Practice, 813  
 Transportation Club of Indianapolis: The Railway Situation and Its Causes, 767  
 Transportation System of the Steel Corporation, 481†, 486\*  
 Traveling Engineers' Association: Annual Convention, 273, 315†, 331  
 Trestle (See Bridge)  
 Trucks:  
 All-Steel Trucks of C. P. R., 1163\*  
 Bearings (See Bearings)  
 Link Side Bearing Truck, 1167\*  
 Tender Truck, Equalized Swing Motion, 386  
 Trust (See also Finance; also Public, Railways' Relations with)  
 Tunnel (See also Subway):  
 Canadian Northern at Montreal, 640†, 651\*  
 Clinchfield Extension, C. C. & O., 861\*  
 Louisville & Nashville Tunnel Work, 143\*, 225\*  
 Moffat Tunnel Report, 1036  
 Tunneling: Explosives for Use in Tunneling, 526  
 Turntable Tractor, 62\*  
**U**  
 Underframe (See Car)  
 Union (See Employee)  
 Unions, Mark Steel, 98\*  
 Union Pacific:  
 Dissolution Plan Approved, 12  
 Educational Bureau, 63  
 Motor Car Troubles, Their Symptoms, Causes and Remedies, 298  
 Ore Transportation, 492  
 Tourist Sleeping Cars, 430  
 Union Switch and Signal Department: Copy Service Department, 301  
 United States Express Company: Annual Report, 669  
 U. S. Metal & Mfg. Co.: Collapsible Stake Pocket, 1169\*  
 United States Steel Corporation:  
 Earnings, 199  
 Profit-Sharing Records, 1036  
 Transportation System, 481†, 486\*  
 Unfilled Tonnage, 160, 714, 927\*  
 Universal Mail Dispatcher Company: Jones' Mail Catcher, 758\*  
 University of Cincinnati: Co-Operative Course in Railway Engineering, 298\*  
 University of Minnesota: Railway Course, 629  
**V**  
 Valuation of Railways:  
 Committees Appointed, 1085

## GENERAL INDEX—Continued.

[Illustrated articles are indicated thus<sup>†</sup>; Editorials thus<sup>‡</sup>; Letters to Editor thus<sup>§</sup>.]

- Valuation of Railways (Continued):  
 Cost of Valuation Work, 242  
 Cost, Original, Versus Cost of Replacement, 450  
 Depreciation or Valuation of Properties, 274\*  
 Equipment Valuation, Assignment by States, 21  
 Federal Valuation Board, 715  
 Illinois, 1036  
 Kansas City Southern Valuation Committee, 469  
 Kansas Railways, 424  
 Maps, Valuation, 527, 598†, 716  
 Minnesota Rate Decisions, Significance of, 89, 139†  
 Pennsylvania System Committees, 27  
 Progress in the Federal Valuation of Railways, 608  
 Railroad Valuation Committee, 18, 160  
 State Commissions to Aid, 26  
 Valuation Commission Applicants, 427, 991, 1053†  
 Valuation Committee, Advisory, 475  
 Valuation Committees, Missouri Pacific, 879  
 Valuation Expenses, Order of Interstate Commerce Commission, 343  
 Valuation of Ohio Railways, 159  
 Valuation of Public Utilities, 444†  
 Valuation of South Dakota Railways, 240  
 Wisconsin, 1036  
 Vanadium (See Wheel)  
 Varnish (See Paint)  
 Ventilator, Cab Window, 1128.  
 Ventilation: Motor-Driven Ventilating Sets for Buildings, 712\*  
 Viaduct (See Bridges and Buildings)
- W**
- Wages (See Employee)  
 Wartime Railroading in Mexico, 702
- Water Service:  
 Concrete Water Trough, 783\*  
 Oil Engine in Railway Water Service, 277†, 289  
 Water Supply, 784  
 Waterways:  
 Panama Canal Work, Last Stages of, 470  
 Halifax Ocean Terminals, 388  
 Stubbs on Waterways, 373  
 Watauga & Yadkin River: Methods of Handling Light Earthwork, 287\*  
 Waycross & Western: Stock Raising to Be Developed, 1090  
 Weighing (See also Scale):  
 Net Weight Law, Tests for, 669  
 Weighing Bureau at Chicago, 527  
 Weir & Craig Manufacturing Company: Turntable Tractor, 62\*  
 Welding:  
 Eccentric Welding, 369  
 Welding and Cutting with Oxygen and Illuminating Gas, 196\*  
 Welin Marine Equipment Company: Crane, Compensating Quadrant, 197\*  
 Wells Fargo & Company Express:  
 Efficiency Committee, 160  
 Foodstuffs, Handling, 384  
 West Coast Lumber Manufacturers' Association: Specification and Rules for Douglas Fir Car Material, 557  
 Western Classification Committee: Made Permanent, 1108†, 1140  
 Westinghouse, George, Receives Grashof Medal, 1136  
 Western Maryland:  
 Air Brake Instruction, 343  
 Engine Terminals, 189\*  
 Gettysburg Celebration Service, 343  
 Safety First, 965  
 Western Pacific:  
 Ferry Steamer, 501\*  
 Fire Prevention, 578  
 Shops at Sacramento, Cal., 564\*
- Western Railway Club:  
 Shop Output, 1005†, 1018  
 Training the Railway Employee, 765  
 Wheel:  
 Drop Test of Heat Treated Chrome Vanadium Wheels, 573\*  
 Wreck Caused by a Broken Tire, 814\*  
 Wrought Steel Wheel, 902  
 Whitewashing (See Paint)  
 Wood (See Ties and Timber)  
 Wood Preservation (See Ties and Timber)  
 Wood Preservers' Association: Tenth Annual Convention, 1177  
 World Circled in Thirty-six Days, 276
- Y**
- Yards and Terminals (See also Station):  
 Bumping Posts, Necessity for, 741†  
 Chicago (See Chicago: Development of Railway Facilities)  
 Chicago Freight Terminal, M. St. P. & S. S. M., 321\*  
 Efficiency in Yard Service, 1113†, 1153†, 1154† (See also Car Service; Movement, Increasing Freight Car)  
 Engine Terminal at Cumberland, Md.; B & O., 709\*  
 Engine Terminals, Western Maryland, 189\*  
 Milwaukee Terminal and Yards, C. M. & St. P., 19\*  
 Montreal Terminal, Canadian Northern, 640†, 651\*  
 Ore Docks at Two Harbors, Minn., 486\*  
 St. Louis Freight Terminal; St. Louis Southwestern, 218\*  
 Silver Grove, Ky., Yard; C. & O., 117\*  
 Terminal at Spokane, Wash.; O.-W. R. R. & N., 817\*  
 Yard at Mechanicville, N. Y.; Boston & Maine, 775\*  
 Young Men's Christian Association: Benefits to Employees, 834

## NEW BOOKS.

- Air Brake Association, 1152  
 American Railroad Economics, 1213  
 American Society for Testing Materials, 1212  
 American Society for Testing Materials Index, 485  
 Atlas of Railway Traffic Maps, 601  
 Civil Engineers' Pocket-Book, 135  
 Commission Regulation of Public Utilities, 946  
 Design of Plate Girders, 1059  
 Diagram Giving Stresses in Beams, 813  
 Edward A. Mosely, The Life Work of, 601  
 Electric Interlocking Handbook, 402  
 Factory Lighting, 694  
 Field Engineer's Handbook, 742  
 Foreign Markets for Railway Supplies and Equipment, 554  
 Freight Rates: Studies in Rate Construction, 319  
 Government Ownership of Railways, 1112  
 International Association for Testing Materials, 1212  
 Laboratory Manual of Testing Materials, 1212  
 Locomotive Boiler Construction, 742  
 Lure of the Iron Trail, The, 402
- Manual of Statistics; 1913 Edition, 83  
 Master Blacksmiths' Association Proceedings, 1913 Convention, 1152  
 Metallography of Iron and Steel, 1213  
 Overhead Electric Power Transmission, 1212  
 Places of Pilgrimage for American Travelers, 601  
 Poor's Manual of Public Utilities, 5  
 Proceedings of the Fifth Annual Convention of the Tool Foremen's Association, 1152  
 Proceedings of the Society for the Promotion of Engineering Education, 694  
 Railway General Foremen's Association Proceedings, 1913, 1152  
 Railway Library for 1912, The, 601  
 Railway Signal Engineering, 44  
 Railway Track Handbook, 946  
 Reinforced Concrete Wall Footings and Column Footings, 770  
 Resuscitation, 601  
 Rules of Management, 554  
 Safety Through the Block Signal System, 900  
 Sayings and Writings About the Railways, 363
- Science of Burning Liquid Fuel, The, 44  
 Solution of Railroad Problems by the Slide Rule, 44  
 Standard Specifications for Steel and Steel Products, 900  
 Statistics of Railways, 900  
 Steam Consumption of Locomotive Engines from the Indicator Diagrams, 173  
 Steel Designing, 5  
 Strength of Beams in Flexure, The, 813  
 Strength of Materials, 1213  
 Suspension Bridges, 1213  
 Transformer Practice, 813  
 Traveling Engineers' Association Proceedings, 1913 Convention, 1152  
 Truth About the Railroads, The, 1112  
 Universal Directory of Railway Officials, 1913, 363  
 Wright on Building Arbitrations, 813  
 Wright on Quantities, 645  
 Year Book of the American Society for Testing Materials, 1213

## PERSONAL.

[Portraits are indicated thus.\*]

- Adams, Prof. Henry C., 575  
 Allen, A. E., 251  
 Allen, Charles W., 585, 1146\*  
 Anderson, James C., 1144  
 Appleton, Walter C., 889  
 Baird, J. B., 1001\*  
 Barrows, Walter A., 251\*  
 Bee, William G., 352\*  
 Beggs, J. H., 35\*  
 Begien, R. N., 74\*  
 Bell, J. O., 128  
 Bennett, J. L., 434\*  
 Bentley, H. T., 841\*  
 Biscoe, Howard M., 433\*  
 Blaess, A. F., 724  
 Blair, J. P., 840  
 Blakeley, Henry, 1044  
 Blaser, F. E., 159  
 Borland, William J., 575  
 Boyie, Edward F., 672  
 Bradford, C. C., 637\*  
 Bretzfeld, Silas W., 887  
 Brown, Brooks G., 724  
 Brown, William C., 953\*  
 Browne, L. C., 433  
 Bull, W. F., 582  
 Burt, A. M., 1205  
 Bush, Benjamin F., 150\*  
 Bush, H. C., 1144\*  
 Butler, Pierce, 833  
 Butler, W. W., 1206\*  
 Caldwell, George Kearsley, 538  
 Clifford, E. A., 1002  
 Clough, William P., 372\*  
 Connors, F. E., 1045  
 Cook, H. G., 311\*  
 Coughlin, W. G., 1145\*  
 Crownover, G. M., 583\*  
 Croxton, Warner Winston, 311  
 Cunningham, C. S., 633  
 Cunningham, J. L., 311\*  
 Cunningham, W. J., 722\*, 740  
 Dailey, M., 250  
 Dawson, Ralph F., 888  
 Deschenes, Edmund, Jr., 722  
 Devans, E. J., 723\*  
 Dickson, J. B., 1245\*  
 Douglass, Dana C., 801  
 Downing, I. S., 584\*  
 duBray, Arthur B., 1000  
 Eaton, Osmon L., 583\*  
 Elliott, Frank S., 350\*  
 Elliott, Howard, 177\*  
 Everett, William Curren, 635  
 Fleming, David B., 676\*  
 Ford, E. L., 433\*  
 Foss, Arthur P., 166  
 Foster, Charles Beverly, 167  
 French, C. L., 537\*  
 Fyfe, R. C., 1144\*  
 Gardiner, E. P., 434  
 Gardner, G. Clinton, Jr., 1145\*  
 Garstang, William, 1245\*  
 Gibbs, J. W., 1045\*  
 Gifford, H. E., Jr., 890  
 Goss, W. F. M., 26  
 Grenfell, E. I., 1000\*  
 Griffin, Thomas A., 1248\*  
 Gumbes, J. H., 1245  
 Hadley, Dr. Arthur T., 549  
 Hadley, Herbert S., 833  
 Hannaford, J. M., 373\*  
 Harrison, Fairfax, 1084\*  
 Harrop, J. L., 431  
 Hattan, W. C., 1246\*  
 Hayes, Carlos A., 167  
 Hensley, L. J., 722\*  
 Hilton, Alexander, 802\*  
 Hine, Major Charles, 723\*  
 Hodgson, John L., 477  
 Holbrook, F. S., 800\*  
 Hudson, E. E., 938\*  
 Hulme, T. W., 1001\*
- Hustis, James H., 179\*  
 Hyndman, F. T., 34\*  
 Ilyzer, E. M., 1204\*  
 Jacobs, M. H., 888  
 Jenks, C. O., 207  
 Johnson, Charles W., 841\*  
 Johnson, James Edward, 167  
 Johnson, J. M., 250\*  
 Jones, W. I., 311\*  
 Kain, Edward M., 208  
 McDonald, Morris, 88\*  
 McGraw, Thomas W., 582  
 McIlwaine, Charles L., 351  
 McMurney, M. G., 801\*  
 Mackenzie, Hugh D., 889\*  
 McQuillen, J. E., 393  
 McWhite, George Edwin, 394  
 Mann, A. C., 478\*  
 Mantell, John J., 1245  
 Marshall, J. F., 76  
 Martin, W. S., 476\*  
 Mays, F. K., 539\*  
 Mellen, Charles S., 426  
 Milner, B. B., 842  
 Moore, James S., 1096  
 Motsett, Charles H., 635  
 Moriarty, G. A., 724\*

Nelson, C. W., 723\*  
 Nelson, Fred W., 802  
 Neville, Maurice A., 393  
 Newlean, J. W., 800\*  
 Nicholson, Macy, 251  
 Nixon, W. C., 914\*  
 Noble, L. C., 253\*  
 Passmore, H. E., 803\*  
 Patterson, Geo. E., 250\*  
 Patterson, Harry E., 801  
 Pearce, Hollis C., 351\*  
 Porcher, Samuel, 252\*  
 Prendergast, R. Q., 167\*  
 Prendergast, W. E., 1144\*  
 Price, Alfred, 207  
 Purdy, Frank A., 1147\*

Quayle, Robert, 841\*  
 Reinhardt, A. M., 34\*  
 Rettinghouse, H., 841\*  
 Rich, Edson Prosper, 249\*  
 Richards, J. T., 75\*  
 Risley, Fred. Smith, 676  
 Schmolz, G. A., 311  
 Schumacher, T. M., 840\*  
 Sesser, John C., 166\*  
 Shaw, Arthur Campbell, 208  
 Slade, George Theron, 393  
 Slocum, Ernest F., 435\*  
 Smart, George E., 889  
 Smith, A. H., 1129\*  
 Smith, Charles Edward, 208

Spratt, Thomas, 394  
 Stevens, James Paul, 537  
 Stewart, C. F., 434  
 Stone, A. J., 1244\*  
 Stone, Everett E., 536  
 Strickler, T. J., 310  
 Stringer, W. T., 840  
 Sweetman, E. M., 1001\*  
 Taylor, Leon R., 878  
 Thompson, Harrison G., 210\*  
 Trenary, G. H., 34\*  
 Tyter, James D., 888\*  
 Underwood, W. H., 538  
 Van Winkle, J. Q., 165\*

von Donop, Lieut.-Col. P. G., 160  
 Wallace, John F., 63  
 Warnock, Harry Rose, 635  
 Watkins, R. C., 128\*  
 Watlington, Edgar H., 1147  
 Watters, J. H., 477\*  
 Whitcomb, F. L., 1247\*  
 Wiggins, William D., 76  
 Winchell, B. L., 51\*  
 Wise, M. J., 887\*  
 Witt, C. C., 310  
 Wood, Frederick H., 1000  
 Woodworth, J. G., 722\*  
 Wolfersberger, S. C., 582  
 Worcester, H. A., 208\*

ELECTIONS AND APPOINTMENTS.

Abeles, Robert, 350  
 Abeles, Robert, Jr., 350  
 Aagard, P., 724  
 Abbott, George W., 477  
 Abeles, J. D., 350  
 Adams, A. B., 351, 393  
 Adams, Edward L., 802  
 Adams, F. G., 208  
 Adams, G. W., 1001, 1044  
 Adams, Guy, 1000, 1096  
 Adams, H. M., 251  
 Adams, T. T., 129  
 Aird, G. A., 350  
 Akans, E. L., 842  
 Allen, A. E., 251  
 Allen, E. R., 1205  
 Allen, J. E., 840  
 Allen, N. C., 33  
 Allen, P. C., 936  
 Allen, W. B., 250  
 Allen, W. K., 1,000  
 Alling, E. W., 539  
 Alsip, J. F., 1204  
 Amos, J. L., 538  
 Anderson, A. J., 537, 583  
 Anderson, F. T., 433  
 Anderson, James C., 1144  
 Anderson, P. E., 35  
 Anderson, R. J., 393  
 Andrew, A. G., 75  
 Andrews, Frank, 74  
 Andrews, George W., 310  
 Ansley, L. M., 1144  
 Anthony, Mark, 583  
 Appleton, W. U., 677, 889  
 Armsby, E. H., 75  
 Armstrong, A. G., 34  
 Armstrong, Frank, 801  
 Armstrong, R. F., 887  
 Arn, Wm. G., 1001  
 Arnold, Brent, Jr., 888  
 Attwater, H. P., 477, 1001  
 Auch, Ira S., 208  
 Austin, C. B., 1001  
 Avery, W. W., 888  
 Avila, Henry, 1044  
 Bacon, G. H., 433  
 Bagley, G. B., 538  
 Baird, A. M., 1045  
 Baird, F. C., 1144  
 Baird, H. L., 1144  
 Baird, J. B., 888, 937, 1001  
 Baker, C. D., 128  
 Baker, J. L., 1144  
 Baldwin, J. F., 433  
 Baldwin, W. A., 1205  
 Ball, Webb C., 1096  
 Barclay, D. B., 477  
 Barker, B. S., 165  
 Barkley, J. O., 538  
 Barnes, Lee, 129  
 Barnes, R. Lea, 128  
 Barnes, William C., 1245  
 Barnes, W. E., 677  
 Barrett, J. Lee, 723, 888  
 Barrett, Richard L., 207  
 Barrows, W. A., 251  
 Bartlette, O. H., 801  
 Batchelder, E. W., 1205  
 Bate, S. M., 937  
 Bates, F. E., 1144  
 Baum, W. W., 251  
 Beacom, T. H., 1244  
 Beam, J. C., 888  
 Beardsley, W. F., 583  
 Reauman, L., 477  
 Becker, R. A., 802  
 Beckett, F. T., 1205  
 Beggs, J. H., 35  
 Bezien, R. N., 74, 676  
 Bell, J. O., 33, 128  
 Bennett, G. W., 676  
 Bennett, J. L., 351, 434  
 Benschoter, C. A., 888  
 Bentley, Charles S., 350  
 Bentley, H. T., 841, 842  
 Benton, I. A., 583  
 Berry, H. H., 350  
 Best, J. H., 130  
 Bettis, H. I., 1096, 1204  
 Beyers, O. S., Jr., 35

Beyers, B. C., 250  
 Bibby, William, 34  
 Biddle, W. B., 74, 1143  
 Bills, Parker, Shields & Brown, 1096  
 Bills, John C., 1096  
 Bisbee, F. M., 434  
 Bishop, H. L., 889  
 Bishop, John T., 889  
 Biscoe, Howard M., 433\*, 434  
 Bissell, F. E., 676  
 Black, Chas. N., 476  
 Blackman, C. S., 538  
 Blaess, A. F., 434, 724, 889  
 Blair, E. S., 538  
 Blair, J. P., 840  
 Blair, S. K., 433  
 Blair, W. L., 433  
 Blake, W. C., 130  
 Blakeley, Henry, 937, 1001, 1044  
 Bland, A. S., 75  
 Blaser, Gus, 937  
 Blech, C. K., 1245  
 Blewett, V. A., 538  
 Blood, C. C., 35, 167  
 Bodamer, Edward, 936  
 Boehm, W. A., 802  
 Boggs, J. E., 1097  
 Boles, E. H., 33  
 Bollons, W., 129  
 Bond, Thomas, 887  
 Booth, P. W., 635  
 Booth, W. L., 393  
 Borner, William, 1246  
 Boschke, G. W., 129  
 Bothwell, C. K., 538  
 Bowden, J. F., 311  
 Bowen, A. C., 310  
 Bowersox, Charles, 1097  
 Bowes, T. F., 34, 74  
 Bowman, D. M., 888  
 Boyce, G. F., 801  
 Boyd, C. D., 208  
 Boyle, A. A., 888, 1044  
 Boylston, S. C., Jr., 350  
 Boynton, R. D., 252  
 Brady, F. P., 250  
 Brandt, H., 310  
 Brass, J. L., 129  
 Breckenridge, B. T., 888  
 Brendel, F. L., 350  
 Bretschmeider, W., 393  
 Bretzfeld, Silas W., 887  
 Breece, G. W., 676  
 Brimson, George M., 249  
 Brinton, J. C., 840  
 Brittain, H. B., 310  
 Brooks, C. E., 310, 936  
 Brooks, W. G., 1205  
 Brosnahan, T. F., 583  
 Broughton, M. H., 635, 676  
 Brown, A., 208  
 Brown, B. G., 538, 724  
 Brown, C. D., 129  
 Brown, C. M., 840  
 Brown, Charles W., 1096, 1097  
 Brown, Collingwood B., 75  
 Brown, E. L., 128  
 Brown, E. N., 128, 676  
 Brown, F. W., 840  
 Brown, H. E., 582  
 Brown, Harry G., 1044  
 Brown, Harry S., 1143  
 Brown, J. A., 250  
 Brown, L. M., 477  
 Brown, L. S., 250  
 Brown, Orno M., 34  
 Brown, S. M., 538  
 Brown, W. C., 1000  
 Brown, W. W., 74  
 Browne, L. C., 433  
 Brownell, C. B., 538  
 Brumley, D. J., 1045  
 Bruner, Howard, 583  
 Buchanan, J. S., 350  
 Buchannon, W. B., 249  
 Buckley, M. J., 128  
 Ruick, James M., 310  
 Bull, W. F., 537, 582  
 Bullard, C. L., 1143  
 Burch, H. F., 887  
 Burckhalter, F. L., 1205  
 Burgess, S. E., 889

Burgess, T. H., 635  
 Burke, F. J., 477, 538  
 Burns, J. B., 677  
 Burns, Robert, 1245  
 Burns, W. H., 74  
 Burrell, C. F., 1205  
 Burres, L. G., 33  
 Burt, A. M., 1143, 1145, 1205  
 Bush, B. F., 128, 676  
 Bush, Harry Charles, 1144  
 Butler, Frank J., 350  
 Butler, S. S., 250  
 Butler, W. S., 351  
 Butz, J. W., 1000  
 Byers, B. C., 1096, 1143  
 Byers, Robert F., 1097  
 Byrne, W. B., 1044  
 Cahill, M. H., 936  
 Cain, D. D., 434  
 Cain, P., 129  
 Caldwell, G. K., 538  
 Calkins, C. H., 635  
 Calvin, William J., 1097  
 Cameron, Wilfred S. R., 888  
 Campbell, A. Q., 635  
 Campbell, F. C., 434  
 Campbell, Roy B., 840  
 Campbell, Y. C., 250, 310  
 Cannon, C. S., 350  
 Cannon, J., 840  
 Card, W. A., 33  
 Carmichael, J., 129  
 Carothers, J. B., 74  
 Carroll, W. F., 1044  
 Carson, C. E., 801  
 Carter, A. J., 33  
 Carter, E. E., 1204  
 Carter, William H., 801, 1143  
 Casson, Robert, 1096  
 Castron, H. G., 677  
 Cathcart, J. M., 584  
 Causey, W. B., 801  
 Chamberlin, E. J., 840  
 Chandler, G. A., 207  
 Chandler, H. W., 251  
 Chapman, C. A., 537  
 Charlton, R. C., 130  
 Chavannes, E. A., 722  
 Cheesman, A. W., 538  
 Cheney, M. P., 34  
 Chesney, C. R., 889  
 Chesvers, W. H., 888  
 Chisholm, W. C., 207  
 Chittendon, G. C., 35  
 Choate, F. B., 537  
 Church, John E., 128  
 Claiborne, C. O., 1204  
 Clark, C. M., 1204  
 Clark, H. R., 1145  
 Clarke, R. E., 33, 393  
 Clarkson, W. S., 539  
 Cleaver, F. C., 350  
 Cleaver, G. C., 1097  
 Cleveland, George C., 635  
 Clifford, E. A., 937, 1002, 1245  
 Clifford, J., 434, 889  
 Clifford, J., 937  
 Clough, W. P., 249  
 Cobb, E. R., 74  
 Coble, W. M., 937  
 Coe, J. A., 676  
 Coe, T. W., 477  
 Coffin, George W., 350  
 Colbert, James T., 74, 207  
 Colclough, R., 128  
 Coleman, D'Alton C., 166  
 Coleman, J. F., 1204  
 Collett, R., 1205  
 Collins, W. W., 1143  
 Comer, E. T., 249  
 Condon, D. M., 252  
 Conlan, J. H., 250  
 Conn, I. J., 1045  
 Connelly, P. C., 250  
 Connors, F. E., 937, 1045  
 Coogan, M. T., 800  
 Cook, H. G., 167, 311  
 Cook, John S., 477  
 Cook, R. A., 167  
 Coons, R. F., 538  
 Cooper, H. A., 538

Cooper, R. L., 1246  
 Cooper, W. L., 130  
 Copony, A., 434  
 Corbett, William H., 1096  
 Cornell, F. R., 350  
 Cornell, J. D., 1245  
 Cornell, W. S., 840  
 Cosgrove, J. H., 477  
 Costigan, W. C., 434  
 Costin, E. M., 166  
 Cottrell, H. M., 583  
 Cotter, U. G., 1143  
 Coughlin, T. M., 887  
 Coughlin, W. G., 1096, 1097, 1145  
 Coulston, J. R., 583  
 Courtney, J. E., 538  
 Cousley, W. T., 252  
 Cowley, J. P., 582  
 Coyes, J. M., 538  
 Coyle, T. E., 1143, 1244  
 Coyne, O. E., 723  
 Cox, L. J., 75  
 Cox, O. W., 75  
 Crabbe, W. G., 582  
 Craig, J. A., 251  
 Craig, J. L., 350  
 Crane, W. S., 676  
 Crowder, R. V., 583  
 Crowell, John W., 1044  
 Crowl, W. S., 1097  
 Crownover, G. M., 393, 583  
 Croxton, W. W., 166, 311  
 Cruice, F. P., 724  
 Cumberland, G. H., 635  
 Cummins, J. J., 1204  
 Cundry, W. H., 583  
 Cunningham, E. E., 888  
 Cunningham, J. L., 252, 311  
 Cunningham, William J., 676, 722  
 Curran, W. G., 936  
 Curtis, D. C., 842  
 Curtis, Stanton, 310  
 Cushing, T., 393  
 Cutler, J. G., 35  
 Cutler, J. M., 251  
 Dabney, Charles T., 583  
 Daggett, F. D., 840  
 Daggett, S. F., 1044  
 Dahler, A. M., 476  
 Dailey, M., 207, 250  
 Daily, C. B., 35, 129  
 Daily, J. J., 208, 937  
 Daley, J. H., 539  
 Dana, C. C., 75  
 Dancy, M. W., 677  
 Danner, G. W., 74  
 Dare, S. H., 537  
 Davidson, Albert, 208  
 Davis, George J., 129  
 Davis, H. A., 434  
 Davis, J. M., 1244  
 Davis, M. P., 1205  
 Dawson, R. F., 676, 888  
 Dean, J. S., 1244  
 DeForce, J. L., 1143  
 Deimling, J. F., 1145  
 Delahunt, W. V., 310  
 Dempster, Gilbert, 802  
 Denham, J. S., 1096  
 Denney, C. E., 724  
 Deschenese, Jr., E., 582, 722  
 Deuel, Guy A., 538  
 Devans, E. J., 676, 723  
 Dewey, C. E., 75  
 Dickie, L. B., 537  
 Dickinson, F. B., 888  
 Dickson, J. B., 1205, 1245  
 Doner, E., 887  
 Donnelly, J. J., 582  
 Donahay, J. A., 676  
 Dooley, M. J., 538  
 Douglas, C. Dallas, 1143  
 Douglas, J. S., 33  
 Douglass, D. C., 128, 801  
 Dow, F. C., 310  
 Dow, F. M., 582  
 Dowdell, T. J., 1044  
 Downing, D., 539  
 Downing, I. S., 477, 584  
 Downs, Lawrence A., 128, 166  
 Doyle, James, 250

## ELECTIONS AND APPOINTMENTS—Continued.

- Doyle, J. W., 1044  
 Droege, John A., 537  
 Drummond, H. N., 350  
 Dryden, C. H., 129  
 Drysdale, H. S., 538  
 Drysdale, W. F., 1246  
 duBray, Arthur B., 1001  
 Duer, J. V. B., 1097  
 Duke, A. W., 434  
 Duke, J. B., 33  
 Dunkle, H. O., 1205  
 Dunlop, P. T., 129, 311  
 Durrett, J. L., 34  
 Durrett, W. B., 1001  
 Duval, J. E., 250  
 Dwelle, Lee A., 1205  
 Dye, Edward A., 888
- Eagan, W. T., 582  
 Earp, G. H., 538  
 Easley, F. J., 1245  
 Easton, F. W., 477  
 Eaton, J. C., 723  
 Eaton, O. L., 537, 583  
 Eckels, C. P., 1205  
 Eddy, A. G., 166  
 Edcomb, E. F., 75  
 Edmonds, A. S., 538  
 Ekin, W. L., 75  
 Elliott, Charles, 393  
 Elliott, F. S., 166, 350  
 Elliott, Howard, 393  
 Ellis, J. H., 470  
 Ellis, T. L., 34  
 Ellzey, T. F., 840, 888  
 Emerson, T. M., 1244  
 Enright, J. F., 937  
 Ensign, C. P., 583  
 Epler, J. E., 33  
 Eslick, F. C., 433  
 Estep, H. C., 34  
 Estes, P. N., 889  
 Eudaly, E. R., 888  
 Everett, W. C., 582, 635  
 Eversman, Frank, 801  
 Ewing, D. L., 75
- Faherty, William J., 251, 537  
 Fallon, James P., 801  
 Fargo, W. S., 129  
 Farmer, I. H., 538  
 Farmer, R. R., 166  
 Farnsworth, Ellis, 538  
 Farr, E. A., 350  
 Farrell, J. W., 393  
 Farrell, W. H., 537  
 Fariss, J. M., 1044  
 Feiser, W. J., 801  
 Fell, H. E., 1000  
 Field, C. J., 166  
 Finley, W. W., 1096  
 Fisher, Charles D., 1097  
 Fisher, G. A., 889  
 Fitzgerald, J. A., 635  
 Flavin, J. T., 724  
 Fleming, D. B., 582, 676  
 Fleming, H. B., 250, 350  
 Flick, John, 537  
 Florence, C. A., 888  
 Flounders, W. R., Jr., 936  
 Flynn, Charles, 1045  
 Flynn, Frank H., 676  
 Fogg, W. H., 676  
 Folger, G. H., 676  
 Foote, C. F., 802  
 Ford, T. S., 165  
 Fordyce, William C., 310  
 Foreman, R. J., 75, 208  
 Forgasan, J. W., 250  
 Foss, Arthur P., 74, 166  
 Foster, C. B., 129, 167, 539  
 Foster, W. E., 207  
 Foster, William H., 537  
 Fox, C. B., 538  
 Fox, C. H., 676  
 Fox, Eugene, 1245  
 Francis, William C., 582  
 Frank, S. E., 166  
 Franklin, F. S., 75  
 Fraser, G. M., 537  
 Fraucndiener, W. J., 477, 583, 677  
 Fredenburg, B. W., 888  
 Freeman, Charles H., 75  
 French, C. L., 537  
 Frey, W. J., 889  
 Frost, W. J., 208  
 Fullem, T. J., 724  
 Fuller, W. F., 350  
 Funk, George H., 889  
 Furry, F. C., 34  
 Fyfe, R. C., 1144
- Gale, William H., 1097  
 Galivan, J. B., 477, 801  
 Galloway, G. E., 936  
 Gardiner, E. P., 434  
 Gardner, G. Clinton, Jr., 1145  
 Gardner, H. W., 889  
 Garner, R. D., 635  
 Garstang, Wm., 1245  
 Garvin, R. A., 350  
 Gaven, J. J., 128  
 Gay, C. E., Jr., 635  
 Geiger, George, 477
- Gibbons, J. M., 677  
 Gibbs, Frank, 842  
 Gibbs, J. W., 1045  
 Gibson, J. B., 1245  
 Gibson, S. W., 166  
 Gifford, F. C., 477, 538  
 Gilcreast, F. W., 1097  
 Githens, J. N., 251  
 Given, W. H., 476  
 Glidden, E. R., 33  
 Glover, W. H., 208  
 Godfrey, T. F., 538  
 Goeldner, E. A., 1143  
 Goitra, Edward F., 310  
 Goodbody, Thomas P., 249  
 Goodchild, A. A., 167  
 Goodwin, E. P., 393  
 Gordon, J. A., 310  
 Gourley, C. F., 724  
 Graham, J. F., 129  
 Graham, Jos., 677  
 Gray, D. G., 888  
 Gray, H. R., 350  
 Green, F. W., 250  
 Greenwood, J. L., 1245  
 Greer, B. B., 33  
 Greer, James D., 1001  
 Greig, A. S., 936  
 Grenfell, E. I., 801, 1000  
 Gresham, W. B., 350  
 Griffin, J. M., 538  
 Grimm, C. C., 582  
 Grimshaw, H. B., 477  
 Groening, W. C., 208  
 Grove, Ben R., 936  
 Guerin, W. H., 1205  
 Guild, W. H., 129  
 Gullickson, Gustav, 840  
 Gumbes, Joseph H., 1096, 1245  
 Gumm, F. L., 1001  
 Guppy, R. T., 1205  
 Gurney, R. L., 310
- Hackett, J. W., 1001  
 Hall, J. E., 249  
 Hall, W. T., 33  
 Halliday, James O., 537  
 Hamilton, George W., 583  
 Hamilton, P. H., 583  
 Hammel, W. A., 351  
 Hammond, E. W., 1097  
 Hancock, George A., 129  
 Hancock, J. A., 33  
 Hanna, E. E., 74  
 Hannaford, J. M., 249  
 Hannam, M. J., 840  
 Hansel, Charles, 76  
 Hanson, C., 208  
 Hanson, R. G., Jr., 1097  
 Hanassen, Frederick, 393  
 Harris, J. M., 129  
 Harris, Page, 477  
 Harrison, Fairfax, 1096  
 Harrison, F. E., 129, 1144  
 Hartman, H. K., 433  
 Hartsough, W. H., 888  
 Haskell, E. A., 477  
 Hatfield, M. B., 75  
 Hattan, W. C., 1097, 1246  
 Havelly, J. C., 583  
 Havens, P. M., 477  
 Haver, W. M., 676  
 Hawkins, William P., 130  
 Hay, F. L., 584  
 Hayes, C. A., 75, 167  
 Hayes, H. B., 937  
 Hayes, T. J., 207, 676  
 Hayler, George W., 75  
 Hazelgrove, R. L., 434  
 Hazlehurst, L. W., 888  
 Hazzard, J. I., 677  
 Heaphey, A. J., 537  
 Heed, T. D., 128, 936  
 Hellen, Joseph, 537  
 Hellicfi, R. H., 76  
 Helm, Lawrence N., 350  
 Helm, T. A., 538  
 Helmick, W. J., 393  
 Henderson, S. Y., 251  
 Henderson, William, 1143, 1205  
 Hennessee, T. W., 677  
 Henry, J. M., 1097  
 Henry, W. J., 723  
 Hensley, C. H., 1204  
 Hensley, L. J., 433, 722  
 Hering, S. A., 129  
 Herlihy, F. J., 677  
 Hess, J. J., 538  
 Hevron, Joseph W., 166  
 Hewes, H. P., 129, 166  
 Heyser, E. S., 840  
 Hibbard, I. L., 801  
 Hickey, G. L., 310  
 Hickey, J. E., 208  
 Hightower, R. E., Jr., 129  
 Hill, C. C., 1145  
 Hillebrand, F. B., 583  
 Hillis, J. A., 128  
 Hilton, Alexander, 802  
 Hilton, S. F., 1205  
 Hinkins, G. S., 635  
 Hinc, Charles, 723  
 Hitch, C. B., 351  
 Hitch, Robert M., 249, 250
- Hitchcock, J. R., 477, 801  
 Hixon, J. F., 583  
 Hoag, E. C., 1143  
 Hobbs, George S., 74, 801  
 Hodges, P. C., 75  
 Hodgson, J. L., 434  
 Hodson, L. E., 74  
 Hoffman, C. M., 252  
 Hogan, M. F., 166  
 Holbert, H. B., 207, 676  
 Holbrook, Frederick S., 800  
 Holman, J. R., 130  
 Holstein, Otto, 537  
 Homan, W. H., 128  
 Homer, J. L., 75  
 Hood, J. E., 351  
 Hoopes, E. L., 76  
 Hopkins, Guy, 250  
 Hopper, W. P., 249  
 Horn, Henry J., 128  
 Horsman, Clifford B., 75  
 Hough, William, 722  
 Houston, W. O., 538  
 Howard, Charles, 676  
 Howard, W. F., 393  
 Howe, H. A., 166  
 Howell, F. M., 350  
 Howson, G. N., 840, 842  
 Hoyt, Wm. E., 538  
 Hudson, S. M., 677, 800  
 Hudson, W. R., 393  
 Hughes, A. S., 251  
 Hughes, R. T., 801  
 Hull, G. A., 129, 477  
 Hull, W. F., 936  
 Hulme, Thomas W., 1001  
 Hundley, E. F., 1001  
 Hunter, John H., 249  
 Hursh, C. M., 434  
 Hurst, W. C., 310, 476  
 Hussey, N., 801  
 Hustis, J. H., 393  
 Hyndman, F. T., 34  
 Hyzer, Edward M., 1204
- Imbrie, James, 249  
 Irvin, C. A., 1204  
 Israel, W. M., 129  
 Izard, A. C., 538
- Jackson, C. H., 251  
 Jackson, Felix, 74  
 Jacobs, Dan, 538  
 Jacobs, M. H., 888  
 Jackie, W. M., 129  
 James, John M., 1096, 1097  
 James, R. L., 350  
 Jarvis, W. L., 128  
 Jasper, C. H., 583  
 Jefferson, Mark, 802  
 Jeffery, Edward T., 128  
 Jenkins, J. F., 635  
 Jenkins, W. J., 130  
 Jenka, C. O., 166, 207  
 Jennev, H. T., 583  
 Jones, George A., 723  
 Johanson, J. E., 75  
 Johns, M. E., 1205  
 Johnson, Charles W., 841\*  
 Johnson, Frank, 842  
 Johnson, George E., 802  
 Johnson, H. C., 75  
 Johnson, J. M., 165, 250  
 Johnson, Jack W., 350  
 Johnson, James Edward, 167  
 Johnson, Kepler, 74  
 Johnson, L. E., 74  
 Johnson, R. M., 350  
 Jones, C. W., 165, 1244  
 Jones, E. T., 33  
 Jones, M. W., 167  
 Jones, W. I., 251, 311  
 Jutz, J. F., 350
- Kaderly, W. F., 250, 310  
 Kain, Edward M., 129, 208  
 Kamps, S. L., 207, 476  
 Kane, F. W., 724  
 Karr, E. J., 936  
 Kavanaugh, J. I., 538  
 Kearton, Wilfred, 35  
 Keaveny, T., 393  
 Kelleher, George C., 393  
 Keller, I. M., 208  
 Kelly, E. M., 1143  
 Kelsey, F. D., 936  
 Kendall, W. L., 801  
 Kenly, John R., 1244  
 Kenly, R. G., 802  
 Kenworthy, J. D., 538  
 Keough, E. M., 1145  
 Kerley, M. S., 251  
 Kern, H. F., 477  
 Kernan, W. P., 801  
 Kerr, G. H., 129  
 Kessell, A. C., 166  
 Kessell, J. E., 166  
 Killian, J. M., 635  
 Kilpatrick, J. B., 351  
 King, B. D., 583  
 King, John S., 723  
 King, J. T., 33  
 Kirchner, C. F., 1143, 1204  
 Kirkman, A. A., 1044
- Klein, Louis F., 34  
 Kline, W. C., 129  
 Klippel, E. A., 129  
 Klock, R. A., 539  
 Knapp, J. W., 393  
 Knapp, Lester R., 129  
 Kneubuhl, A., 433  
 Knowl, W. M., 582  
 Knowles, L. D., 538  
 Kohlhammer, A. H., 676  
 Koiler, E. S., 250  
 Koons, R. P., 76  
 Kruttschnitt, John, 1045  
 Kuhns, J. C., 351
- Laden, P., 936  
 Lamb, William, 1044  
 Lamoreaux, S. J., 888  
 Landon, G. W., 582  
 Lane, Mills B., 249  
 Langer, J. T., 129  
 Lauderdale, J. H., 350, 635  
 Lawler, Oscar, 1096, 1204  
 Lawrence, James J., 477  
 Lay, C. C., 74  
 Lay, R. E., 1044  
 Leahy, W. H., 166  
 Leard, H. S., 166, 350  
 Lee, A. M., 936  
 Lee, George H., 75  
 Leland, F. A., 840  
 Letts, G. P., 583  
 Lewis, Maj. E. C., 1244  
 Lewis, H. E., 128  
 Lewis, R. H., 393  
 Leyden, W. T., 208  
 Lightner, A. D., 350  
 Lillie, G. W., 129, 477  
 Lillenthall, Jess W., 476  
 Limming, L. B., 537  
 Lincoln, F. B., 1205  
 Lindsay, J., 166  
 Lindsey, J. C., 34  
 Linthicum, J. C., 35  
 List, E. H., 350  
 Little, H. H., 477  
 Little, Wm. G., 310  
 Livingston, E. E., 802  
 Livingston, J. J., 888  
 Livingston, W. E., 207  
 Lock, A. E., 1044  
 Lomax, E. L., 251  
 Long, L. H., 165  
 Lorraine, H. K., 1144  
 Lorton, J. G., 33  
 Lucia, L. G., 75  
 Lucky, A. B., 801  
 Luke, I. H., 887, 936  
 Luscombe, J. T., 677  
 Lusk, James W., 1143  
 Lyon, H. L., 130
- McAllister, W. K., 477  
 McAtee, P. B., 583  
 MacBain, D. R., 724  
 McBride, W. C., 538  
 McBurney, J. W., 350  
 McCabe, J., 539  
 McCampbell, T. C., 74  
 McCarthy, A. D., 393  
 McCarthy, C. A., 677, 841  
 McCarthy, C. C., 538  
 McCarthy, T. C., 676  
 McCarty, R. E., 801  
 McCarty, R. J., 433  
 McCauley, F. E., 1044  
 McClellan, E. E., 840  
 McClure, J. C., 165  
 McCnnonico, W. B., 75  
 McCue, P. L., 1245  
 McCullough, J. W., 635  
 McDonald, A. B., 937  
 McDonald, D., 128, 252  
 McDonald, Morris, 74  
 McDonald, R. H., 129  
 McDougall, George, 677  
 McEwen, J. J., Jr., 74  
 MacEwen, J. J., 1143  
 McFadden, E. H., 635  
 McFarland, G. A., 74  
 McFarlang, R. E., 351  
 McGaw, T. W., 477, 582  
 McGinnis, H. M., 888  
 McGrain, E. O., 393  
 McGreevey, John, 208  
 McGuire, P., 35  
 McIlvaine, C. L., 252, 351  
 McInerney, M. G., 676, 801  
 McIntosh, F., 33  
 McKee, D. H., 676  
 Mackenzie, Hugh D., 677, 899  
 McKenzie, J. J., 1205  
 McKoy, T. H., 129  
 McLaren, J. B., 249  
 McLennan, J. D., 249  
 McMaster, A. E., 208  
 McMullin, C. E., 887  
 McNamee, O. B., 840  
 McNeill, B. M., 888  
 McNeill, R. G., 129  
 McNicholl, George A., 724  
 McQuillen, J. E., 311, 351, 393  
 McVea, J. C., 433  
 McWhite, George Edwin, 394

- McWilliams, R. M., 538  
 Maass, Bennett, 947  
 Machmer, R. B., 129  
 Macklin, H. C., 434  
 Madden, John, 74  
 Mager, F. W., 302  
 Maher, G. W., 34  
 Mahoney, C. W., 1001  
 Mahoney, T. S., 1096  
 Maloney, P. J., 1096  
 Malum, L. F., 166  
 Manion, J. L., 75  
 Mann, A. C., 351, 478  
 Mann, C. O., 350  
 Mann, J. K., 676  
 Mann, L. E., 350  
 Manning, George C., 129  
 Mantell, J. J., 1205, 1245  
 Marble, F. B., 1145  
 Markham, L. A., 636  
 Marshall, J. F., 35, 76  
 Martin, Henry, 1204  
 Martin, S. A., 251  
 Martin, W. S., 393, 476  
 Mason, H. T., 1096  
 Mason, T. H., 393  
 Matchette, W. P., 1205  
 Matheson, J. D., 129  
 Mayo, Robert, Jr., 129  
 Mays, F. K., 351, 539  
 Meek, John L., 888  
 Melanson, H. H., 251  
 Melchior, William J., 582  
 Mellen, C. S., 74, 165  
 Melvin, R. C., 1245  
 Merrick, H. J., 723  
 Merritt, Wesley, 75  
 Metzger, George W., 677  
 Meyer, C. E., 801  
 Meyer, J. F., 128  
 Middleton, D. M., 208  
 Miles, W. L., 1044  
 Miley, C. F., 802  
 Mill, J. C., 208  
 Millard, C. S., 676  
 Milligan, T. F., 350  
 Milner, B. B., 842  
 Mitchell, Elmer, 677  
 Mitchell, F. E., 1044  
 Mitchell, W. A., 129  
 Mitcnell, W. N., 167  
 Mizener, Logan A., 350  
 Monroe, Lee, 310  
 Montague, Howard C., 208  
 Montgomery, Hugh, 75, 351  
 Montgomery, M. F., 1097  
 Moodie, D. E., 130  
 Moore, A. B., 129  
 Moore, E. D., 477  
 Moore, J. L., 1143  
 Moore, J. S., 1044, 1096  
 Moore, S. B., 476  
 Moore, W. H., 840  
 Moorman, D. L., 888  
 Moran, H. G., 1245  
 Mored, H. S., 677  
 Morgan, J. A., 75, 251  
 Morgan, M. B., 1001  
 Moriarity, G. A., 538, 724  
 Morris, A. G., 1143  
 Morris, A. I., 937  
 Morris, A. R., 167  
 Morris, George C., 74  
 Morris, E. C., 722  
 Morris, H. H., 393  
 Morris, J. A., 1143  
 Morrison, S. A., 128  
 Morrison, W. W., 635  
 Morriss, A. J., 1044  
 Morrow, W. A., 477  
 Morse, C. A., 75  
 Motsett, Charles H., 635  
 Moutaund, A. F., 433, 476  
 Mozier, W. R., 722  
 Mudge, H. U., 165  
 Mudret, Harry Decatur, 33  
 Mullaly, T. D., 1144  
 Mulvihill, W. J., 1044  
 Munsell, I. W., 75  
 Murphy, C., 166  
 Murphy, F. A., 1145  
 Murphy, George, 1145  
 Murphy, William, 250  
 Myrover, George C., 350
- Nash, E. E., 1044  
 Nelson, C. W., 723  
 Nelson, F. W., 538, 802  
 Neuffer, J. G., 393  
 Neville, J. A., 250, 350, 393  
 Newhall, Daniel S., 209  
 Newlean, J. W., 676, 800  
 Newton, C. H., 74  
 Nicholson, J., 207  
 Nicholson, M., 166, 251  
 Niswonger, E. A., 251  
 Nixon, W. C., 74, 936, 1143  
 Noble, S. W., 1044  
 Norris, Charles G., 1205  
 Norris, I. I., 129  
 Norton, I. M., 538  
 Norton, P. B., 1205  
 Noyes, Walter C., 310
- O'Brien, Frank, 1000  
 O'Brien, J. E., 724
- O'Connor, D. J., 433  
 O'Donnell, Joseph P., 1044  
 O'Gallagher, John P., 166  
 O'Hara, Charles, 433  
 O'oughlin, W. M., 35  
 O'Neill, J. H., 166  
 O'Neill, W. H., 74  
 O'Neill, W. J., 841  
 Opdyke, Wm. S., 310  
 Oren, Fred B., 1001  
 Orndorff, J. R., 1145  
 Orrock, J. W., 75  
 Osborne, H. J., 129  
 Osborne, S. H., 635  
 Osborne, W., 351  
 Ouellet, D. O., 723  
 Oviatt, Harry C., 537, 538  
 Owen, G. B., 167
- Page, I. M., 252  
 Palmer, J. H., 250  
 Paquette, C. A., 1145  
 Parish, R. G., 889  
 Parker, Shields & Brown, 1096  
 Parker, H. A., 129  
 Parker, H. H., 677  
 Parker, R. H., 539  
 Parrish, E. J., 433  
 Parsons, F. W., 129  
 Parsons, R. S., 1204  
 Paschall, W. E., 350  
 Passmofe, H. E., 802  
 Patterson, C. H., 75  
 Patterson, George E., 166, 250  
 Patterson, H. E., 676, 801  
 Patton, A. J., 1245  
 Patton, F. E., 801  
 Patton, J. O., 583  
 Payne, G. W., 538  
 Payne, W. T., 75  
 Peabody, E. W., 310  
 Peacock, W. T., 251  
 Pearce, H. C., 167, 351  
 Pennick, W. H., 677  
 Perkins, C. E., 251  
 Perkins, H. J., 1097  
 Peters, Harold L., 208  
 Peterson, Ira N., 433  
 Peyton, John H., 1244  
 Pfeifer, W. C., 888  
 Phelps, H. A., 34  
 Phinney, R. H., 1204  
 Pierce, H. H., 888  
 Pierce, J. E., 677  
 Pierce, O., 310  
 Pillsbury, W. R., 635  
 Pindell, Thomas H., 476  
 Place, P. N., 74  
 Plott, John F., 434, 1001  
 Pointer, T. H., 1044  
 Porch, D. L., 537  
 Porcher, Samuel, 209, 252  
 Porter, B. A., 936  
 Porter, C. D., 129  
 Porter, C. H., 208, 840  
 Porter, Fred R., 208  
 Portlock, W. M., 434  
 Potts, C. E., 33  
 Powell, J. M., 801  
 Powrie, W. R., 538  
 Prendergast, R. Q., 75, 167  
 Prendergast, W. E., 1144  
 Preston, W. C., 208  
 Price, A., 128, 166, 207  
 Price, F., 433  
 Prince, B. C., 1244  
 Pritchard, R. W., 1205  
 Pryatt, J. S., 249
- Quayle, Robert, 841, 842  
 Quigley, Joseph, 937  
 Quimby, F. W., 676
- Randall, C. T., 802  
 Randolph, K., 1000  
 Rankin, E. C., 538  
 Rath, Charles K., 75  
 Rawls, Leslie, 208  
 Rawson, D. H., 433  
 Ray, D. L., 538  
 Ray, William F., 636, 676  
 Redmond, F. A., 840  
 Reed, James, 477  
 Reed, John M., 350  
 Reed, W. H., 538  
 Reese, Zack J., 393  
 Reich, J. H., 33  
 Reid, C. H., 538  
 Reid, D. G., 840  
 Reinhardt, A. M., 34  
 Rettinghouse, H., 841, 887  
 Reynolds, J. P., 1097  
 Rhame, M. D., 538  
 Rhodes, C. B., 251  
 Rhodes, J. W., 888  
 Rice, N. M., 937  
 Rich, Edson Prosper, 33, 249  
 Richards, J. T., 75  
 Richardson, R. S., 350  
 Riggs, Howard E., 676  
 Riley, Wm., 722  
 Risley, C. H., 128  
 Risley, F. S., 582, 676  
 Roach, I. B., 677  
 Robb, George W., 538  
 Robbins, F. S., 129  
 Robertson, A. A., 583
- Robertson, Alexander, 165, 676  
 Robertson, F. C. N., 722  
 Robinson, A. C., 724  
 Robinson, D. H., 840  
 Robinson, G. L., 1144  
 Rochester, R. K., 33, 75  
 Rockwell, Samuel, 635  
 Rodgers, T. J., 582  
 Rogers, Charles L., 310  
 Rogers, H. B., 888  
 Rohrer, J. A., 802  
 Rollings, C. M., 350  
 Rose, L. S., 1097  
 Rosevear, A. E., 75  
 Rosing, W. H. V., 936  
 Rothmeyer, W., 583  
 Rourke, John, 887  
 Rowland, S. V., 33  
 Royce, F. D., 251  
 Rupp, W. H., 937  
 Russell, C. A., 129  
 Ryan, E. H., 676
- Saluson, C. T., 801  
 Sanderson, C. H., 393  
 Sanford, F. B., 166  
 Sarvey, A. L., 1145  
 Sasser, J. W., 1144  
 Sayles, Chas. J., 350  
 Scandrett, H. A., 393  
 Scherp, J. J., 1001  
 Schreur, Lee B., 208  
 Schlacks, Charles H., 128  
 Schleyer, G. H., 74, 207  
 Schmidt, C. B., 583  
 Schmidt, W. G., 434  
 Schmoll, G. A., 311  
 Schneider, R. F., 677  
 Schreck, I. C., 250  
 Schroyer, C. A., 842  
 Schulze, R. W., 477, 538  
 Schumacher, T. M., 840  
 Scott, L. G., 802  
 Scott, Thomas K., 476, 635  
 Scribner, W. H., 129  
 Seales, E. J., 311  
 Secor, N. W., 583  
 Seddon, W. L., 635  
 Senger, J. W., 477  
 Sesser, J. C., 166  
 Seymour, George S., 722  
 Shafer, A. B., 1205  
 Shannon, J. R., 350  
 Sharp, T. F., 433  
 Sharpe, H. W., 677  
 Shattuck, J. A., 249  
 Shaw, A. C., 129, 208  
 Shaw, H. J., 393  
 Shaw, Robert, 1001  
 Sheer, A. G., 1205  
 Shelton, T. A., 33  
 Shepherd, A. W., 1096  
 Sheridan, H. W., 250  
 Shipley, J. E., 635  
 Shirah, L. C., 350  
 Shoemaker, C. A., 801  
 Shoop, William R., 724  
 Shorter, R. G., 887  
 Shreeve, George J., 936  
 Shumate, C. A., 350  
 Shutt, H. E., 888  
 Simmons, Frederick L., 722  
 Simmons, T. D., 1096  
 Simms, L. N., 1143  
 Simpson, R. W., 584  
 Sinclair, A. E., 1245  
 Singleton, J., 1045  
 Slade, G. T., 249, 393  
 Slattery, J. T., 887, 936  
 Slowey, James F., 208  
 Smart, George E., 724, 889  
 Smith, C. A., 251  
 Smith, C. E., 129, 208  
 Smith, C. F., 936  
 Smith, E. C., 840  
 Smith, G. C., 75  
 Smith, George W., 75  
 Smith, M. F., 1205  
 Smith, R. H., 1143  
 Smith, T. G., 74  
 Smith, T. M., 433  
 Smith, W. C., 1145  
 Smith, W. R., 166, 937, 1044, 1143  
 Smith, William J., 888  
 Smithan, N. L., 677  
 Smock, Leroy G., 129  
 Smock, R. G., 840  
 Sorg, Charles, Jr., 635  
 Souerby, Fred W., 537  
 Sparks, Ingram T., 1245  
 Soies, C. B., 1143  
 Spratt, Thomas, 351, 394  
 Springer, J. E., 250  
 Stack, J. D., 129, 809, 936  
 Staley, W. C., 477, 538  
 Stayton, W. D., 433  
 Stedman, E. A., 166  
 Steinel, Alvin T., 583  
 Steltenkamp, J. A., 538  
 Stephens, R. S., 129  
 Stevens, Donald French, 537  
 Stevens, Henry D., 249  
 Stevens, J. J., 635  
 Stevens, J. P., 393, 537  
 Stewart, Charles F., 350, 434  
 Stewart, C. J., 538
- Stewart, J. B., 1144  
 Stewart, M. D., 1001  
 Still, H. E., 1001, 1044  
 Stocker, F. P., 166  
 Stockton, E. H., 251  
 Stokes, G. A., 537  
 Stokes, William D., 434  
 Stoltz, C. F., 1097  
 Stone, Albert J., 1204, 1244  
 Stone, G. M., 840  
 Stone, H. M., 889  
 Storey, D. A., 251  
 Strain, C. W., 250  
 Stringer, W. T., 840  
 Stuart, F. C., 351  
 Stuart, J. C., 1204, 1244  
 Styers, J. V., 1144  
 Sullivan, F. J., 537  
 Sullivan, M. C., 393  
 Sullivan, P. A., 251, 677  
 Sullivan, Timothy H., 166  
 Sutherland, C. G., 128  
 Sutton, John G., 1143  
 Sweetman, E. M., 842, 1001  
 Sweeney, D. R., 677
- Talbot, John S., 888  
 Tate, K., 677  
 Taussig, J. E., 33, 351, 477  
 Taylor, C. M., 129, 477  
 Taylor, D. L., 129  
 Taylor, E. E., 582  
 Taylor, E. S., 887  
 Taylor, F. J., 635  
 Taylor, H. M., 476  
 Taylor, Isaac Maxwell, 840  
 Taylor, J. H., 166  
 Taylor, J. L., 393  
 Taylor, R. W., 129  
 Temple, H. H., 936  
 Terrell, Roy, 583  
 Thomas, F. R., 1097  
 Thomas, George W., 1044  
 Thomas, J. H., 129  
 Thomas, John W., Jr., 1244  
 Thomas, W. C., 583  
 Thomas, William, 801  
 Thompson, Herbert, 129  
 Thompson, J. F., 350, 583  
 Thompson, W. H., 74, 75  
 Thomson, F. M., 802  
 Thomson, George, 208, 477  
 Thrower, D. W., 434, 889, 1001  
 Timm, E., 75  
 Tiffin, S. G., 252  
 Tillet, C. H., 802  
 Tintling, Alex., 1044  
 Titus, C. L., 310  
 Tobin, Garland, 538, 802  
 Todd, C. H., 208  
 Torrance, H. M., 250  
 Townsend, W. B., 583  
 Toye, C. C., 75  
 Trelford, T. W., Jr., 251  
 Trelford, W. R., 1044  
 Trenary, G. H., 33, 34  
 Trickett, G. M., 208  
 Trimble, J. B., 538  
 Tritsch, C. M., 583  
 Trott, E. W., 677  
 Trowbridge, W. R., 76  
 Trumbull, R. S., 166  
 Tucker, Sydney J., 477  
 Turner, Avery, 74  
 Turner, C. G., 252  
 Turner, F. C., 937  
 Twynman, J. L., 393  
 Tyler, W. T., 207  
 Tyter, James D., 676, 888
- Uhlman, F. C., 476, 582, 1096  
 Underwood, W. H., 433, 538
- Van Buskirk, H. C., 351  
 Van Hecke, D., 74, 166  
 Van Horn, C. W., 582, 676  
 Van Nerte, W. F., 888  
 Van Vliet, B. F., 1143  
 Van Winkle, J. Q., 128, 165  
 Van Zant, A. R., 583  
 Veasey, V. L., 249  
 Veitch, J. R., 677  
 Vincent, W. H., 722  
 Violett, R. C., 1145  
 Vollmer, J. C., 937  
 Voorhees, H. B., 74, 676  
 Voss, Charles N., 676  
 Voss, Harry F., 166  
 Votaw, G. E., 166
- Wadleigh, Frank A., 251  
 Waldron, A. B., 538  
 Waldron, N. A., 635, 677  
 Walker, C. C., 393  
 Walker, F., 433  
 Walker, F. B., 677  
 Walker, W. K., 1246  
 Wallace, C. L., 1045  
 Wallace, John F., 249  
 Wallace, Joseph A. S., 1245  
 Wallace, S. M., 1001  
 Wallace, William A., 208  
 Walsh, F. J., 351  
 Walton, P. G., 393, 477  
 Ware, Clarence P., 583  
 Warner, A. B., 889  
 Warnock, H. R., 383, 635



## ELECTIONS AND APPOINTMENTS—Continued.

Waters, J. J., 351  
 Watkins, R. C., 33, 128  
 Watson, J. D., 840  
 Watters, J. H., 477  
 Watts, J. F., 434  
 Weatherley, E. P., 1205  
 Weaver, C. E., 434  
 Webb, C. H., 310  
 Webb, E. B., 677  
 Weber, DeRoo, 350  
 Webster, F. E., 75  
 Wedding, H. A., 582  
 Weeks, Otis, 477  
 Weiberg, E. A., 677  
 Weiler, G. S., 477  
 Weir, R., 350  
 Welch, J. P., 433  
 Weller, R. C., 1097  
 Wells, A. G., 801  
 Welsh, Maurice A., 539  
 Welshonce, E. P., 635  
 Welty, Donald C., 636  
 West, John T., 350  
 West, Thomas H., 1143

Westbury, C. W., 889  
 Westcott, M. A., 75  
 Westerman, F. N., 888  
 Weston, H. H., 1001  
 Whalen, R. F., 1045  
 Wharton, C. E., 477  
 Wheeler, George R., 129  
 Wherritt, W. C., 801  
 White, L. M., 538  
 White, P. T., 207  
 Whinton, W. M., 1244  
 Whitham, Harry, 802  
 Whitney, J. E., 166  
 Whittington, A. G., 1204  
 Wickersham, C. A., 635  
 Wegand, F. B., 724, 802  
 Wiggins, W. D., 33, 34, 76  
 Wilcox, E. M., 252, 724  
 Wilder, D. U., 1096  
 Wiles, S. H., 129  
 Willcutt, G. B., 476  
 Williams, Alfred, 1143  
 Williams, Mrs. Cora B., 393  
 Williams, F. M., 1205

Williams, F. W., 35, 129  
 Williams, G. E., 477  
 Williams, H. F., 208  
 Williams, J. P., 393  
 Williams, M. R., 1001  
 Williams, N. A., 936  
 Williams, R. F., 538  
 Williams, S. D., Jr., 538  
 Williams, Walter S., 128  
 Williams, W. H., 1145  
 Wilson, E., 128  
 Wilson, H. R., 635  
 Wilson, J. B., 1205  
 Wilson, James G., 887  
 Winchell, B. L., 74, 75  
 Wing, P. L., 1096  
 Winsor, G. H., 165  
 Wise, J. W., 74  
 Wise, M. J., 801, 887  
 Wolfersberger, S. C., 537, 582, 676  
 Womble, C. C., 537  
 Womson, S. L., 538  
 Wood, A. R., 801  
 Wood, B. F., 1097

Wood, B. T., 936  
 Wood, F. H., 887, 1000  
 Wood, P. O., 1205  
 Woodard, C., 635, 801  
 Woodfin, J. E., 538  
 Woods, C. W., 74  
 Woods, R. O., 130  
 Woodward, Clayton N., 357  
 Woodworth, James G., 722  
 Wooley, P. E., 433  
 Worcester, H. A., 128, 208  
 Wortham, E. S., 35  
 Wright, C. A., 128  
 Wright, E. E., 1143  
 Wroe, W. L., 801  
 Wyman, O. C., 207, 801

Yantis, Frank S., 310  
 Young, H. D., 802

Zeigler, E. H., 676, 1143  
 Zollinger, L. R., 1097  
 Zook, Morris A., 434, 802

## OBITUARY.

[Portraits are indicated thus.\*]

Adreon, Edward L., Jr., 1046  
 Aird, Gordon A., 167  
 Andrews, George, 677

Barnett, William E., 724  
 Bettis, Horace I., 1045  
 Borner, William, 1246  
 Boutell, Alexander A., 1046  
 Brady, Anthony N., 209  
 Brown, Alexander, 76  
 Brown, Frank E., 842

Carskaddon, Benjamin W., 842  
 Charlton, James, 1045\*  
 Cook, John S., 434, 478\*  
 Coughlin, John J., 351  
 Crary, George W., 394  
 Crawford, James H., 1205

Doherty, Charles J., 628

Emerson, Thomas M., 1035  
 Ensign, John F., 636\*  
 Evarts, Maxwell, 677

Finley, W. W., 1034\*

Fitzgerald, Thomas J., 35  
 Florence, Charles A., 724

Gilmore, Frank M., 1248  
 Girten, W. F., 210  
 Gordon, William G., 889  
 Grafton, W. McC., 725\*

Hagerman, James, 1097  
 Hanson, Arthur S., 209  
 Harris, Joseph E., 1002  
 Hartman, H. W., 677  
 Haskell, Frederick A., 889  
 Haupt, Samuel B., 636  
 Hill, David S., 130  
 Hopkins, Sidney Wright, 1248  
 Hudson, S. M., 677

Ingham, William Armstrong, 584  
 Irwin, George L., 394

Johann, Jacob, 889  
 Johnson, W. P., 1002  
 Jones, Dwight A., 1145

Kretzinger, George W., 1002

Lee, George F., 842  
 Lewis, Benjamin Tucker, 726, 803  
 Luther, Reese Zollinger, 802

MacKinnon, Paul R., 130  
 Marble, John H., 1005, 1042\*  
 Martin, Henry, 1145  
 McRoberts, G., 130  
 Musson, C. S., 1205

Newhall, Daniel Smith, 130  
 Noble, L. C., 168  
 Noble, Stephen W., 802

Parrott, Joseph Robinson, 725\*  
 Pfender, C. E., 1002  
 Pope, Alfred A., 312\*  
 Prindiville, E. S., 842

Ramsey, Matthew J., 937  
 Ray, William F., 636  
 Rhame, Mitchell D., 1205  
 Roach, Milton C., 1002  
 Robertson, Frederick C. N., 478  
 Rodgers, Ashmead Gray, 890

Sandberg, Christer P., 1246  
 Savage, F. S., 1246  
 Schreiber, Henry B., 633  
 Silver, Herman, 394  
 Smith, Charles H., 937  
 Smith, James, 636  
 Smith, William Carpenter, 394  
 Sprigg, William Osbourne, 842  
 Stetson, Adelbert B., 1003  
 Sutherland, David S., 1246

Taft, Edward A., 209  
 Taussig, Dr. William, 130  
 Taylor, C. M., 434  
 Taylor, J. H., 167  
 Thomas, John W., Jr., 1205  
 Thompson, Henry Martyn, 130  
 Totten, R. C., 1207\*  
 Trimble, Judge J. McD., 539

White, E. T., 677  
 Wiley, J. R., 844  
 Williams, A., 1002  
 Woods, Edwin S., 1003\*

## INTERSTATE COMMERCE COMMISSION RULINGS.

[See also General Index.]

Acme Portland Cement Company v. American Express Company, 885

Allentown Portland Cement Company v. Philadelphia & Reading et al., 72

American Agricultural Chemical Company v. Bangor & Aroostook et al., 1043

American Brake Shoe & Foundry Company v. Belt Railway Company of Chattanooga et al., 1092

Aransas Pass Channel & Dock Company v. Galveston, Harrisburg & San Antonio et al., 72

Arizona Corporation Commission v. Atchison, Topeka & Santa Fe, 1042

Atlanta Journal Company et al. v. Seaboard Air Line et al., 247

Atlantic Packing Company of Baltimore City et al. v. American Express Company et al., 431

Birge-Forbes Company v. Missouri, Kansas & Texas et al., 1092

Board of Trade of Carrollton, Ga., et al. v. Central of Georgia et al., 248

Board of Trade of the City of Chicago v. Chicago & Alton et al., 125

Boney & Harper Milling Company v. Atlantic Coast Line et al., 1043

Boston Chamber of Commerce et al. v. Atchison, Topeka & Santa Fe et al., 392

Bruce & West Manufacturing Company v. Erie Railroad et al., 206

Bureau of Railroad Commissioners of the State of Montana v. Denver & Rio Grande et al., 123

California Pole & Piling Company et al. v. Southern Pacific, 164

Carnegie Board of Trade et al. v. Pennsylvania Company et al., 244

Cedar Rapids Commercial Club v. Chicago, Rock Island & Pacific, 244

City of Montezuma, Ga., v. Central of Georgia et al., 839

Clinton Sugar Refining Company v. Chicago & North Western Railway Company, 1092

Colorado Manufacturers' Association et al. v. Atchison, Topeka & Santa Fe et al., 247

Columbia Chamber of Commerce v. Southern Railway et al., 998

Commercial Club of Omaha v. Anderson & Saline River Railroad Company et al.; and 17 other cases disposed of in the report itself or the orders entered herein, 32

Commercial clubs of the city of Duluth v. Baltimore & Ohio et al., 164

Consolidated Fuel Company et al. v. Atchison, Topeka & Santa Fe et al., 124

Consolidated Pump Company v. Lake Shore & Michigan Southern et al., 72

Crutchfield, Woolfolk & Clore et al. v. Florida East Coast Railway et al., 885

Dairymen's Supply Company v. Pennsylvania Railroad et al., 1093

Dillon Coal & Transfer Company v. Oregon Short Line et al., 244

Dixie Dairymen's Association v. Yazoo & Mississippi Valley, 124

East Duquesne Supply Company v. Illinois Central, 1092

Eastern Wheel Manufacturers' Association et al. v. Alabama & Vicksburg, 32

Federal Milling Company v. Minneapolis, St. Paul & Sault Ste. Marie et al., 164

Frankie Grain Company v. Illinois Central et al., 205

Gottson Brothers Company v. Genesee & Wyoming et al., 206

Hampton Manufacturing Company v. Old Dominion Steamship Company et al., 164

Haverhill Box Board Company v. Boston & Maine et al., 931

Hennepin Paper Company et al. v. Northern Pacific et al., 164

Holland Blow Stave Company v. Atlantic Coast Line et al., 123

Huerfano Coal Company et al. v. Colorado & Southern et al., 1203

In re advances in rates for the transportation of lumber and shingles from North Pacific Coast territory to points in Minnesota, Wisconsin and other states, 72

In re coal rates from the anthracite regions to points on the New Haven Railroad, 349

In re Express Rates, Practices, Accounts and Revenues, 1042

In re investigation and suspension of advances in charges by carriers for the refrigeration of carload shipments of fruit, vegetables, etc., between points in Colorado and Utah, 885

In re investigation of alleged irregularities and discrepancies in the weighing of freight by carriers subject to the acts to regulate commerce, 248

In re investigation and suspension of advances in class and commodity rates between points in Iowa and Minnesota and points in Pacific territory, 206

In re investigation and suspension of advances in rates by carriers for the transportation of butter and eggs from Topeka, Kan., to Memphis, Tenn., and other points, 164

In re investigation and suspension of advances in rates by carriers for the transportation of coal and other commodities between Zeigler, Ill., and points in Missouri, Iowa and other states by cancellation of joint rates in connection with Chicago, Zeigler & Gulf, 32

In re investigation and suspension of advances in rates by carriers for the transportation of cotton seed and cotton seed products from points in Texas to New Orleans, La., 347

In re investigation and suspension of advances in rates by carriers for the transportation of hard-wood and other kinds of lumber and articles manufactured therefrom from points in Arkansas, Louisiana, and other points to Memphis, Tenn., St. Louis, Mo., and other points of destination, 124

In re investigation and suspension of advances in rates by carriers for the transportation of lumber, shingles, and other articles from points located on the Washington Western Railway to points in Minnesota, Illinois, Indiana and other states, 124

In re investigation and suspension of advances in rates by carriers for the transportation of tin cans and other commodities between points in the state of California and points in other states, 349

In re investigation and suspension of advances in rates by carriers for the transportation of wheat from Kansas City, Mo., and other points, to Edwardsville, Ill., Lawrenceville, Ill., and other points, 32

In re investigation and suspension of new milling-in-transit regulations applicable on the products of corn milled or mixed at Oneonta, N. Y., 31

In re investigation and suspension of Ohio river hay rates, 123

In re investigation and suspension of rates by carriers for the transportation of tin cans and other commodities between points in the state of California and points in other states, 31

In re investigation and suspension of salt rates from Wisconsin to Iowa, etc., 123

In re investigation of alleged unreasonable rates and passages involved in the transportation of live stock, packing house products and fresh meat from various southwestern points to packing houses, and thence to various destinations. Corporation Commission of Oklahoma v. Atchison, Topeka & Santa Fe et al., 998

In re practices and regulations governing the issuance, sale and exchange of mileage books, 885

In re rates, classifications, regulations, and practices of carriers, 73

Iowa State Board of Railroad Commissioners v. Arizona Eastern et al., 247

Keats, H. L., Auto Company v. Oregon-Washington Railroad & Navigation Company et al., 1093

Klauer Manufacturing Company v. Atchison, Topeka & Santa Fe, 1240

Koehler Produce Company et al. v. Pennsylvania Railroad et al., 125

Lagrange Chamber of Commerce v. Atlanta & West Point et al., 244

Lebanon Commercial Club v. Louisville & Nashville et al., 884

Lee, George A., Company v. Illinois Central, 1240

Lesser-Goldman Cotton Company et al. v. St. Louis, Iron Mountain & Southern et al., 164

Louisville Board of Trade et al. v. Indianapolis, Columbus & Southern Traction Company et al., 164

Manufacturers' Railway Company et al. v. St. Louis, Iron Mountain & Southern et al., 247

Marian Coal Company v. Delaware, Lackawanna & Western, 72

Mason Brothers v. Southern Pacific et al., 1043

Mayor and City Council of Vienna, Ga., v. Georgia Southern & Florida et al., 247

Mayor and Council of Douglas, Ga., et al. v. Atlanta, Birmingham & Atlantic, 1043

Memphis Freight Bureau v. Illinois Central et al., 124

Menzies-DuBois Auto Company v. Oregon-Washington Railroad & Navigation Company et al., 1093

Meridian Board of Trade & Cotton Exchange v. Alabama Great Southern et al., 1092

Milliken Refining Company v. St. Louis & San Francisco et al., 72

Milwaukee Maltsters' Traffic Association v. Grand Trunk Western et al., 1093

Minneapolis Cereal Company v. Chicago & North Western et al., 1092

Morton Salt Company v. Buffalo, Rochester & Pittsburgh et al., 206

Morton Salt Company et al. v. Morgan's Louisiana & Texas Railroad & Steamship Company et al., 1044

National Coal Company v. Baltimore & Ohio, 1092

National Lumber Exporters' Association v. St. Louis, Iron Mountain & Southern et al., 306

New England Electric Company v. Chicago, Rock Island & Pacific, 1043

Port Arthur Board of Trade v. Abilene & Southern et al., 73

Railroad Commissioners of the State of Florida v. Atlantic Coast Line et al., 998

Schmidt, Charles F., & Peters, Inc., v. Atchison, Topeka & Santa Fe et al., 1092

Scott-Mayer Commission Company v. Chicago, Rock Island & Pacific et al., 1240

Sheridan Chamber of Commerce v. Chicago, Burlington & Quincy et al., 839

Sioux Terminal Elevator Company et al. v. Chicago, Milwaukee & St. Paul et al., 124

Southwestern Woodenware Company v. Chicago, Milwaukee & Puget Sound et al., 431

Springfield Commercial Association of Springfield, Ill., v. Pennsylvania Railroad et al., 1240

State of Iowa et al. v. Atchison, Topeka & Santa Fe et al., 247

State of Iowa et al. v. Chicago, St. Paul, Minneapolis & Omaha et al., 247

State of Kansas et al. v. Atchison, Topeka & Santa Fe et al., 164

Sterling Salt Company v. Pennsylvania Railroad et al., 206

Suspension of commutation rates between New York and points in Connecticut, 72

Taylor, John, Dry Goods Company et al. v. Missouri Pacific et al., 310, 931

Toledo Produce Exchange v. Ann Arbor et al., 124

Topeka Traffic Association v. Alabama & Vicksburg et al., 31

Town of Pelham, Ga., v. Atlantic Coast Line et al., 1043

Traffic Association of St. Louis Coffee Importers v. Illinois Central et al., 1093

Traffic Bureau of Nashville, Tenn., v. Louisville & Nashville et al., 1243

United Refrigerator & Ice Machine Company v. Chicago & North Western et al., 1043

United States of America v. Union Pacific et al., 1204

Victor Manufacturing Company et al. v. Southern Railway, Enrree Manufacturing Company et al. v. Louisville & Nashville et al., 164

Volco Manufacturing Company v. Atchison, Topeka & Santa Fe, 839

Vulcan Iron Works Company v. Atchison, Topeka & Santa Fe et al., 72

Washington Milling Company v. Norfolk & Western Railway Company et al., 164

Washington, D. C., store-door delivery, 31

Wausau Advancement Association et al. v. Chicago & North Western, 1043

Western Fruit Jobbers' Association of America v. Chicago, Rock Island & Pacific et al., 72

Weyl-Zuckerman & Company v. Colorado Midland et al., 72

RAILWAY CONSTRUCTION.

Alabama & Mississippi, 938

Alberta, Peace River & Eastern, 1207

Albuquerque, Cortez & Salt Lake, 1047

Alexandria & Western, 36

Algoma Central & Hudson Bay, 131, 726, 938

Algoma Eastern, 131, 726, 938

All Red Line Railway, 1003

Alton & Southern, 313, 1207

Alva & Northwestern, 131

Anacortes & Eastern, 313

Anthony & Northern, 253, 585

Appalachian Electric Power & Transit Company, 169

Arizona Roads, 395

Arkansas Interurban, 844

Atchison, Topeka & Santa Fe, 313, 805

Atlantic Coast Line, 1047

Augusta & Edgefield (Electric), 211

Baltimore & Ohio, 436, 1047

Barclay & Riverton, 1099

Big Sandy & Kentucky River, 36

Birmingham, Ensley & Bessemer (Electric), 1207

Birmingham-Tuscaloosa Railway & Utilities Company (Electric), 541

Birmingham & Southeastern, 131

Bismarck, Bellevue Valley & Western, 1003

Black Mountain, 541

Boston & Albany, 1047

Bridgeport & Southern, 395

Brinson Railway, 313

British Columbia Electric, 726

Brooklyn Rapid Transit, 353

Buctouche Railway & Transportation, 313

Buffalo Coal & Lumber Railroad, 1047

Butler County, 353

Butte-Boise Winnemucca, 131, 211, 313

Butte, Wisdom & Pacific, 353, 541

Bryan & Texas Central, 585

Cache Valley, 36

Calgary & Fernie, 131

California, Oregon & Eastern, 211, 436

California Roads (Electric), 805

Camden, Summerville & Gauley Bridge Railroad, 585

Campbellford, Lake Ontario & Western, 479

Canadian Alberta, 938

Canadian Northern, 637, 1249

Canadian Northern Pacific, 637

Canadian Pacific, 77, 131, 211, 313, 436, 479, 726, 805, 891, 938, 1003, 1207.

Canadian Roads, 726, 1099

Carolina & Georgia, 1207

Carolina & Yadkin River, 541

Cary, North & South, 1207

Cedar Rapids & Iowa City, 1099

Central Canada, 938

Central New England, 1147

Central Pacific, 1099

Central Utah, 1207

Charleston Northern, 938, 1207

Charlottesville Interurban, 211

Cherry River & Southern, 1099

Chesapeake & Ohio, 679

Cheyenne Short Line, 169

Chicago & Alton, 679

Chicago & North Western, 36, 585

Chicago, Burlington & Quincy, 637, 805, 844, 891, 1003

Chicago, Milwaukee & St. Paul, 313, 436, 679, 938, 1099, 1249

Chicago, Peoria & Quincy Traction, 726

Chicago, Rock Island & Pacific, 36, 726, 805

Chicago, St. Paul, Minneapolis & Omaha, 1047

Cincinnati, Georgetown & Portsmouth, 1047

Cincinnati, New Orleans & Texas Pacific, 938

Clarksburg-Northern, 585

Clear Lake, 938

Colorado, Kansas & Oklahoma, 211, 313, 805

Colorado Roads, 1047

Colorado, Wyoming & Northern, 726

Columbia & Nehalem, 1047

Cumberland Railroad, 1048

Columbia & Puget Sound, 1047

Columbus, Kenton & Toledo Traction, 353

Colusa & Hamilton, 1099

Coos Bay & Coquille Valley, 726

Copper Range, 77

Corinth & Northeastern, 131

Cumberland Valley Electric, 169, 679

Dakota Eastern, 436

Dallas, Corsicana & Palestine, 353, 436

Dallas, Fairfield & Gulf, 436

Dallas Northwestern Traction, 169

Dallas Southwestern Traction, 169, 1003

Dan River Railway (Electric), 1249

Dayton, Middletown & Cincinnati (Electric), 253

Denver & Rio Grande, 1003

Denver & Salt Lake, 253, 395, 436, 805, 1048

Detroit, Bay City & Western, 541, 1004

Detroit, Lansing & Grand Rapids, 805

Dez Quinze & Blanche River, 891

Dixie Railway, 211

Dolores, Paradox & Grand Junction, 805

Dominion Atlantic, 727, 1004, 1147

Duluth & Iron Range, 436

East & West Coast, 727, 1249

Elberton & Eastern, 36, 1207

Elkin & Allegheny, 479

Erie, 436

Essex Terminal Railway, 805, 1048

Esquimalt & Nanaimo, 131, 1207

Fairmount & Veblen, 585

Florida East Coast, 727

Foristell, Camp Creek & Northeastern, 36

Fort Smith, Poteau & Western, 1048

Fort Worth-Denton Interurban, 1249

Fox & Illinois Union (Electric), 211

Fresno Traction, 353

Frontier Electric, 313

Gainesville Midland, 1048

Georgia Coast & Piedmont, 436

Glen Rose & Walnut Springs, 1048

Goldboro, Seven Springs & Swansboro, 939

Grand Rapids & Indiana, 131

Grand Rapids & Northwestern, 1048, 1147

Grand Trunk, 353, 479, 805, 939

Grand Trunk Pacific, 131, 541, 939, 1099

Grants Pass-Crescent City, 1099

Great Northern, 211, 313

Great Northern & Gulf Central, 353

Greene County, 844

Green River & Uintah Basin, 805

Greenville, Blue Ridge & Northern, 541

Guadalupe Valley Traction, 169

Gulf, Florida & Alabama, 679, 727, 939, 1048

Gulf, Freeport & Northern, 36, 169, 637

Halifax Terminal, 131

Hastings & Northwestern, 169

Henryetta Interurban, 436, 541, 805

Hiawasse Valley, 395

Hocking Valley, 1048

Hoosac Tunnel & Wilmington, 1048

## RAILWAY CONSTRUCTION—Continued.

- Houston & Brazos Valley, 1099  
Houston & Texas Central, 395, 541, 585, 805  
Hudson Bay Railway, 586
- Idaho Roads (Electric), 541  
Illinois Central, 77, 586, 727  
Illinois Midland, 1249  
Illinois Traction, 541  
Intercolonial Railway, 36, 131, 395, 891, 1004  
Interurban Railroad, 1207
- Jefferson County Traction, 436  
Joliet & Lake Manuan Colonization, 1207  
Joplin & Pittsburg (Electric), 1048
- Kansas City Terminal, 1147  
Kansas, Oklahoma & Southwestern, 637  
Kettle Valley, 211, 313  
Kingston & Excelsior Springs (Electric), 169, 253  
Knoxville & Maryville Interurban, 131
- Lachine, Jacques Cartier & Maisonneuve, 939  
Lake Erie & Eastern, 436  
Lake Erie & Youngstown (Electric), 436, 844  
Latour Creek, 36  
Laurel Light & Railroad, 77  
Lehigh & New England, 1004  
Lexington & Eastern, 36, 586  
Liberty-White, 1004  
Little Rock, Pine Bluff & Eastern Traction, 313  
London, Grand Bend & Stratford, 805  
Lorain, Ashland & Southern, 586  
Louisiana & Arkansas, 541  
Louisville & Nashville, 37, 586  
L'Outre Railroad, 541  
Lyndhurst Lumber Company's Line, 1208
- Macoupin County Extension Railway, 37  
Malvern & Camden, 805  
Manatawny Railroad, 541  
Margaree Coal & Railway, 131  
Maryville-Knoxville Interurban, 132  
Matador & Northern (Electric), 211  
Memphis & Pensacola, 479  
Meskill & Columbia River, 1249  
Metolius, Prineville & Eastern, 1099  
Mexican Roads, 169  
Michigan Central, 541  
Michigan Roads (Electric), 805  
Midland Continental, 939  
Minneapolis, St. Paul & Sault Ste. Marie, 313, 805, 939  
Minneapolis, St. Paul, Rochester & Dubuque Traction, 211  
Minneapolis Union Electric, 939  
Minnesota & International, 169  
Minnesota Central (Electric), 313  
Missouri, Kansas & Texas, 211, 353, 1099  
Moberly, Huntsville & Randolph Springs (Electric), 37  
Mobile & Baldwin County (Electric), 37  
Mound Railway, 1099  
Mojave & Bakersfield, 353, 1099  
Montezuma San Juan Southern, 313  
Montour Railroad, 313  
Montreal & Lake Victoria, 1147  
Montreal & Southern Counties (Electric), 805  
Morrisburg & Ottawa (Electric), 37  
Motley County, 253
- Naas Valley & Northern, 132  
Nacodoches & Southeastern, 313  
Nashville, Chattanooga & St. Louis, 1099  
National Railways of Mexico, 169  
Navajo Southern, 891  
Nebraska Central, 1048  
Nebraska Roads, 313
- New Albany & French Lick Valley Traction, 541  
New River, Holston & Western, 1048  
New York, New Haven & Hartford, 939, 1147  
New York Subways, 77, 169, 253, 353, 395, 541, 586, 679, 805, 844, 891, 939, 1048, 1147  
Nexperce & Idaho 806  
Niagara, St. Catharines & Toronto (Electric), 1048  
Niobrara Water Power Railway, 727  
Norfolk Southern, 77, 586  
Norman Interurban, 353, 1048  
Northern Pacific, 211  
North Louisiana (Electric), 541  
Northport & Southwestern, 395  
North Railway, 1099  
North-Western of South Carolina, 1004  
Northwestern Pennsylvania (Electric), 1048  
North Yakima & Valley, 1099  
Nueces Valley, Rio Grande & Gulf, 637, 727
- Oakland, Antioch & Eastern (Electric), 479  
Oakwood & Trinity River Southern, 132  
Ocilla Southern, 1004  
Ohio River & Columbus, 1048  
Ohio Roads (Electric), 169  
Ohio Southwestern System, 1048  
Oil Belt, 541  
Okeechobee Interurban, 637  
Oklahoma & Texas Central, 541  
Oklahoma, New Mexico & Pacific, 313, 844  
Oklahoma Railway (Electric), 353, 1048  
Oklahoma Roads, 396, 1208, 1249  
Oklahoma Roads (Electric), 353  
Olympia Southern, 132  
Oneida & Western, 844, 939, 1004  
Ontario Lake Front Terminal, 939  
Orangeburg Railway, 313  
Oregon Electric, 1208  
Oregon Short Line, 132, 541, 939, 1148  
Oregon-Washington Railroad & Navigation Company, 637  
Orleans-Kenner (Electric), 169  
Ottawa, Northern & Western, 1004
- Pacific & Hudson Bay, 727  
Pacific Electric, 1208  
Pacific Great Eastern, 542, 806, 1249  
Pacific, Peace River & Athabasca, 939  
Palacios, San Antonio & Pecos Valley, 806  
Palestine, Corsicana & Dallas, 1048  
Pawhuska & Northeastern, 132, 169, 253  
Pee Dee Valley, 77  
Pennsylvania Railroad, 940, 1048  
Pennsylvania Southern, 313, 396  
Petersburg & Columbia Springs, 891  
Piedmont Northern Lines (Electric), 1249  
Pine Bluff & Northern, 211  
Pine Bluff & Southern, 132  
Pittsburgh & Lake Erie, 437  
Pittsburg, Shawmut & Northern, 940, 1099  
Porcupine Rand Belt Electric, 637  
Portland & Oregon City (Electric), 169, 806  
Portland, Eugene & Eastern (Electric), 437, 806  
Puget Sound & Willapa Harbor, 313, 437, 679, 940, 1099
- Quanah, Acme & Pacific, 1099
- Raleigh, Charlotte & Southern, 77, 586, 940  
Rapid Railroad, 1048  
Riviera Beach & Western, 1004  
Rockcastle River, 844  
Rome & Northern, 1148
- St. Elmo, Belle Helena & Louisiana Eastern, 727  
St. John & Quebec, 396, 586
- St. Joseph Valley, 1249  
St. Louis & San Francisco, 77  
St. Louis, Iron Mountain & Southern, 132  
St. Louis, Peoria & North Western, 37  
St. Louis Southwestern, 679, 1049  
St. Paul & Kansas City Short Line, 37  
Sacramento Valley (Electric), 638  
Salem, Falls City & Western, 132  
Salina Canyon, 940  
Salt Lake & Alta, 437, 1049  
Salt Lake & Idaho, 1148  
Saluda-Hendersonville Interurban, 1249  
San Antonio & Austin Interurban, 169, 727  
San Antonio, Fredericksburg & Northern, 479, 940  
San Antonio, Uvalde & Gulf, 132, 253, 313, 844  
San Benito & Rio Grande Valley, 479  
San Luis Central, 806  
San Pedro, Los Angeles & Salt Lake, 1148  
San Rafael & San Anselmo Valley (Electric), 437  
Seaboard Air Line, 679, 1099  
Seattle, Port Angeles & Lake Crescent, 542, 1099  
Shefford, Bagot & Missisquoi, 1049  
Shelby County, 37  
South Dakota Central, 727  
Southern New England, 211, 353, 479  
Southern Pacific, 353, 1099  
Southern Railway, 727  
South Ontario Pacific, 1004  
Southwestern Traction, 170, 845  
Southwestern Traction & Power Company, 170, 727  
Springfield & Pana, 353  
Standard Coal Company's Lines, 77  
Sudbury, Kepawa & Bell River, 891  
Sultan Valley, 542  
Surprise Valley Railway, 254, 353
- Temple, Northwestern & Gulf, 396, 891  
Texas Roads, 396, 1208  
Thesalon & Northern, 1004  
Tilsonburg, Lake Erie & Pacific, 1004  
Timpson & Henderson, 170  
Tobique & Campbellton, 170  
Tonopah & Tidewater, 1099  
Toronto, Hamilton & Buffalo, 437, 806  
Tri-State Railways Company of Michigan, 638, 727  
Tristate Traction, 1208  
Trona Railway, 728
- Ungava Railway, 891  
Union Pacific, 170, 542  
Utah Railroad, 1099  
Utah Roads, 638  
Uwarie & Pee Dee Valley, 845
- Van Horn Valley, 211, 437
- Wabash, 211  
Warren, Johnsville & Saline River, 1208  
Washington & Old Dominion, 254  
Washington Roads, 1208  
Watauga & Yadkin River, 37, 1100  
Watauga Railway, 1100  
Waterloo, Cedar Falls & Northern (Electric), 638, 940, 1100  
West Coast, 638  
Western Maryland, 211  
Weston & Glenville (Electric), 1249  
West Ontario Pacific, 940  
West Virginia & Southern, 1004  
Willamette-Pacific, 1100  
Winnemucca Northern, 845
- Yadkin River, 1100  
Yazoo & Mississippi Valley, 78

## RAILWAY FINANCIAL NEWS.

- Alabama Great Southern, 892, 1100  
Atchison, Topeka & Santa Fe, 170, 314, 480, 892, 1250  
Atlanta, Birmingham & Atlantic, 38, 314, 892  
Atlantic Coast Line, 680  
Atlantic Northern & Southern, 354  
Atlantic Southern Railroad, 354
- Bangor & Aroostook, 78  
Baltimore & Ohio, 170, 437, 587, 1004  
Baltimore & Ohio Chicago Terminal, 680  
Bangor & Aroostook, 806, 845, 892  
Bennettsville & Cheraw, 1148  
Birmingham, Selma & Pensacola, 354  
Boston & Maine, 78, 314, 542, 728, 1250  
Boston, Revere Beach & Lynn, 1049  
Brinson Railway, 354, 437  
Brooklyn Rapid Transit, 437, 542  
Buffalo & Susquehanna, 314, 354, 892, 1004, 1100, 1148  
Buffalo, Rochester & Pittsburgh, 212
- Canadian Northern, 437, 1208  
Canadian Pacific, 38, 437, 1149  
Carolina, Clinchfield & Ohio, 78  
Cassville & Western, 132  
Chesapeake & Ohio, 38, 1148  
Chicago & Alton, 354
- Chicago & Eastern Illinois, 38, 1208, 1250  
Chicago & North Western, 354, 892  
Chicago & Western Indiana, 1049  
Chicago Great Western, 78, 542  
Chicago, Milwaukee & St. Paul, 38, 396, 1250  
Chicago, Rock Island & Pacific, 845, 892, 1148  
Chicago, Terre Haute & Southeastern, 254  
Cincinnati, Hamilton & Dayton, 212  
Cleveland, Cincinnati, Chicago & St. Louis, 396, 728  
Cleveland Short Line, 1208  
Colorado, Kansas & Oklahoma, 396  
Colorado Midland, 638  
Connecticut River Railroad, 638
- Delaware & Hudson, 728, 1250  
Delaware, Lackawanna & Western, 1148  
Denver & Rio Grande, 638  
Denver & Salt Lake, 396, 680  
Detroit, Toledo & Ironton, 38, 254, 638, 806, 1208, 1250
- Eric, 38, 480, 806, 1250
- Fairmount & Veblen, 892  
Fitchburg, 587, 680  
Florida East Coast, 480  
Fort Dodge, Des Moines & Southern, 587, 940
- Fort Worth & Denver City, 1049
- Galveston-Houston Electric, 480  
Galveston, Houston & Henderson, 1049  
Georgia & Florida, 1049  
Greenville & Knoxville, 806
- Hampden Railroad, 1250  
Hawkinsville & Florida Southern, 254  
Hocking Valley, 254, 845, 892
- Illinois Central, 212, 254, 806, 1004, 1049, 1208  
International & Great Northern, 38, 940  
Interstate Transfer Railway, 940
- Kansas & Southwestern, 170  
Kansas City, Mexico & Orient, 354, 1004
- Lake Shore & Michigan Southern, 437, 542  
Lehigh Valley, 542, 1148  
Louisiana & North West, 396  
Louisville & Nashville, 638
- Maine Central, 78  
Manatee & Grand Rapids, 34  
Memphis Union Station, 728  
Mexican Railway, 892  
Michigan Central, 437

Middletown & Unionville, 1100  
 Middletown, Unionville & Water Gap, 892  
 Minneapolis, St. Paul & Sault Ste. Marie, 1250  
 Missouri, Kansas & Texas, 38, 132  
 Missouri, Oklahoma & Gulf, 638, 1208  
 Mobile & Ohio, 38  
 Nashville, Chattanooga & St. Louis, 38  
 National Railways of Mexico, 38, 314, 542, 680, 1004, 1100  
 New Orleans, Mobile & Chicago, 396, 1250  
 New Orleans, Texas & Mexico, 132, 254, 806, 1100  
 New York Central & Hudson River, 132, 542, 892, 1049, 1250  
 New York Connecting, 437, 1004, 1049  
 New York, New Haven & Hartford, 78, 132, 170, 254, 314, 396, 480, 587, 680, 728, 806, 940, 1004  
 New York, Ontario & Western, 638  
 New York, Susquehanna & Western, 892  
 New York, Westchester & Boston, 132  
 Norfolk Southern, 728  
 North & South Carolina, 1100  
 Northern Pacific, 132  
 Northwestern Terminal, 396  
 Oakland, Antioch & Eastern, 38, 132

Ocean Shore, 1049  
 Orange & Northeastern, 806  
 Pacific & Eastern, 38  
 Pacific Railways of Nicaragua, 892  
 Paragould Southeastern, 314, 638, 680  
 Pennsylvania, 170, 638, 845, 1250  
 Philadelphia, Baltimore & Washington, 314  
 Pittsburgh, Cincinnati, Chicago & St. Louis, 314, 396  
 Port Bolivar Iron Ore Railway, 892  
 Rio Grande Junction, 638  
 Rock Island Memphis Terminal Co., 354  
 Rock Island, Stuttgart & Southern, 1148  
 St. Louis & San Francisco, 38, 78, 132, 480, 542, 587, 638, 806, 845, 892, 940, 1004, 1148, 1208  
 St. Louis, Brownsville & Mexico, 132  
 St. Louis, El Reno & Western, 1250  
 St. Louis, Iron Mountain & Southern, 314  
 St. Louis, Peoria & Northwestern, 354, 892  
 St. Louis, Rocky Mountain & Pacific, 170, 314, 354, 1100  
 St. Louis Southwestern, 38, 314, 354, 542, 638, 680

San Antonio, Uvalde & Gulf, 638  
 Sanford & Everglades, 680  
 San Pedro, Los Angeles & Salt Lake, 78  
 Seaboard Air Line, 212, 1100  
 Southern Pacific, 38, 212, 480, 542  
 Southern Railway, 170, 354, 638  
 Sparrows Point, 314  
 Spokane, Portland & Seattle, 38  
 Stephenville North & South Texas, 38  
 Sugar Land Railroad, 132, 845  
 Texas & Pacific, 680  
 Toledo, St. Louis & Western, 892  
 Tonopah & Goldfield, 587  
 Trans-Mississippi Terminal Co., 680  
 Union Pacific, 38, 212, 314, 354, 587, 728, 892  
 Valdosta, Moultrie & Western, 437  
 Valley Terminal Railway, 354  
 Wabash, 132, 170, 212, 1208  
 Wabash-Pittsburgh Terminal, 1208  
 Western Maryland, 1250  
 Western Railway of Alabama, 1148  
 Wheeling & Lake Erie, 132, 314  
 West Jersey & Seashore, 170  
 Williamsville, Greenville & St. Louis, 587

## FOREIGN RAILWAY NOTES.

[See also General Index, under subjects and names.]

Abyssinia, 378  
 Afghanistan, 1249  
 Africa, 37, 56, 150, 354, 413, 458, 479, 493, 573, 638, 649, 656, 757, 759, 804, 843, 914, 917, 1145  
 Argentina, 6, 25, 38, 44, 76, 314, 329, 338, 349, 454, 458, 480, 627, 633, 636, 711, 766, 816, 908, 957, 966, 1024, 1134, 1248, 1249  
 Australia, 53, 61, 73, 118, 202, 209, 435, 437, 502, 587, 703, 804, 825, 892, 913, 981, 1022, 1024  
 Austria, 27  
 Balearic Islands, 377  
 Belgium, 402, 878, 1214  
 Bolivia, 314, 338, 728  
 Brazil, 25, 1246  
 Bulgaria, 908  
 Burma, 431  
 Ceylon, 131, 800  
 Chile, 207, 314, 437, 587, 627  
 China, 25, 51, 58, 73, 76, 78, 132, 170, 174, 178, 181, 207, 209, 420, 458, 542, 614, 793, 843, 952, 990, 1002, 1065, 1194, 1247, 1249  
 Congo, 869  
 Colombia, 10, 157, 170, 212, 326, 420  
 Cuba, 149, 207, 330  
 Cyprus, 780  
 Denmark, 1121

Ecuador, 116, 725  
 Egypt, 423, 426  
 England, 198, 413, 510, 566, 574, 602, 622, 626, 825, 845, 889, 892, 908, 917, 1166, 1248, 1250  
 Formosa, 654  
 France, 291, 446, 576, 1019, 1049, 1128  
 Germany, 698, 744, 986, 1022, 1117, 1122, 1129, 1170, 1247  
 Greece, 431  
 Haiti, 84  
 Honduras, 105, 351, 420  
 India, 18, 38, 61, 90, 97, 105, 112, 131, 182, 217, 220, 224, 229, 235, 249, 310, 389, 394, 418, 446, 540, 584, 587, 604, 608, 614, 658, 694, 802, 937, 940, 1194  
 Italy, 18, 406, 478, 558, 650  
 Japan, 372, 431, 514, 806  
 Java, 1060, 1074  
 Kashmir, 1235  
 Madagascar, 21  
 Madras, 252  
 Malay States, 212  
 Manchuria, 176, 229, 338, 353, 494, 1166, 1246  
 New South Wales, 394, 713, 859

New Zealand, 712, 924, 1193  
 Nigeria, 602  
 Norway, 480  
 Paraguay, 478, 616  
 Philippines, 1021, 1227  
 Queensland, 1083  
 Roumania, 312  
 Russia, 25, 217, 364, 638, 678, 820, 940, 957, 988, 1114, 1250  
 Salvador, 1098  
 San Domingo, 575  
 Scotland, 364, 587  
 Servia, 587  
 Siberia, 509  
 Siam, 212  
 South Australia, 1068  
 Spain, 35, 154, 157, 159, 341, 351, 353, 373, 509, 582, 646, 662, 665, 802, 890, 1033, 1049, 1170  
 Sweden, 1083, 1121, 1134  
 Switzerland, 386, 480, 539, 662, 680, 758, 768, 826, 843, 908, 1244  
 Syria, 1077  
 Turkey, 542, 663, 1018  
 Uruguay, 168  
 Victoria, 1214  
 Zululand, 238



# Railway Age Gazette

PUBLISHED EVERY FRIDAY AND DAILY EIGHT TIMES IN JUNE, BY THE  
SIMMONS-BOARDMAN PUBLISHING COMPANY,  
WOOLWORTH BUILDING, NEW YORK.

CHICAGO: Transportation Bldg. CLEVELAND: Citizens' Bldg.  
LONDON: Queen Anne's Chambers, Westminster.

E. A. SIMMONS, *President.*

L. B. SHERMAN, *Vice-President.* HENRY LEE, *Sec'y & Treas.*  
The address of the company is the address of the officers.

### EDITORS.

SAMUEL O. DUNN, *Editor.*

ROY V. WRIGHT, <i>Managing Editor.</i>	H. H. SIMMONS	E. S. FAUST
W. E. HOOPER	H. F. LANE	F. W. KRAEGER
B. B. ADAMS	E. A. AVERILL	A. D. CLOUD
E. T. HOWSON	R. E. THAYER	GEORGE L. FOWLER
	A. C. LOUDON	

Subscriptions, including 52 regular weekly issues and special daily editions published from time to time in New York, or in places other than New York, payable in advance and postage free:

United States and Mexico.....	\$5.00
Canada .....	5.00
Foreign Countries (excepting daily editions).....	8.00
Single Copies .....	15 cents each

Engineering and Maintenance of Way Edition and four Maintenance of Way Convention Daily issues, North America, \$1.00; foreign, \$2.00.

Entered at the Post Office at New York, N. Y., as mail matter of the second class.

WE GUARANTEE, that of this issue 8,150 copies were printed; that of those 8,150 copies, 6,696 were mailed to regular paid subscribers and \$40 were provided for counter and news companies' sales; that the total copies printed this year to date were 223,050—an average of 8,632 copies a week.

Statement of the ownership, management, etc., of the *Railway Age Gazette*, published weekly at New York, N. Y.:

Editor, SAMUEL O. DUNN, Chicago, Ill.  
Managing Editor, ROY V. WRIGHT, New York, N. Y.  
Publisher, SIMMONS-BOARDMAN PUBLISHING CO., New York, N. Y.

### STOCKHOLDERS:

EDWARD A. SIMMONS, New York.	ROY V. WRIGHT, New York.
LUCIUS B. SHERMAN, Chicago, Ill.	ELMER T. HOWSON, Chicago, Ill.
HENRY LEE, New York.	A. C. BOARDMAN, Riverdale, N. Y.
L. B. RINES, New York.	FRANCIS BOARDMAN, Riverdale, N. Y.
SAMUEL O. DUNN, Chicago, Ill.	B. BOARDMAN, New York.
	RAY MORRIS, New York.

### BONDHOLDERS:

S. W. DUNNING, New York.	CHARLES M. PRATT, New York.
FRANCIS BOARDMAN, Committee, N. Y.	A. B. HENSZEY, Philadelphia, Pa.
JACQUES L. VAUCLAIN, Phila., Pa.	C. W. WALTON, Ridgewood, N. Y.
S. E. KELLOGG, Newton, Mass.	C. C. NEWCOMB, Brooklyn, N. Y.
W. H. SHUEY, Chicago, Ill.	M. D. HORTON, Brooklyn, N. Y.

SIMMONS-BOARDMAN PUBLISHING COMPANY,  
By E. A. SIMMONS, President.

Sworn to and subscribed before Jno. H. Carr, Notary Public for Kings County, N. Y. (No. 133), whose certificate is filed with the County Clerk of New York (No. 9), on April 2, 1913.

VOLUME 55. JULY 4, 1913. NUMBER 1.

## CONTENTS

<b>EDITORIAL:</b>	
Editorial Notes .....	1
The Signal Maintainer .....	2
The Proposed Investigation Regarding Rate Advances .....	3
A Law to Prohibit Railway Safety .....	4
Engineman Schroeder Acquitted .....	4
New Books .....	5
<b>LETTERS TO THE EDITOR:</b>	
The "Conciliation Committee"—A Necessity; by Chas. C. Schnatterbeck .....	5
Government Ownership in Alaska; by Avery Turner .....	6
The Reliability of Automatic Block-Signal Records .....	6
An Early Locomotive Failure; by A. C. Frith .....	6
<b>MISCELLANEOUS:</b>	
Study Your Apprentice Boys Carefully; by G. M. Basford .....	7
*New Montclair Station of the Delaware, Lackawanna & Western .....	9
Freight Rate Advances and the Interstate Commerce Commission .....	10
The Union Pacific Plan as Approved .....	12
Powdered Fuel for Locomotives; by Walter D. Wood .....	13
Train Despatchers' Convention .....	15
*American Society for Testing Materials .....	15
The Railroad Valuation Committee .....	18
*The St. Paul Improvements in Milwaukee .....	19
Assignment of Equipment Valuation by States; by A. I. Thompson .....	21
Need of Better Boxes for Freight .....	23
Newark Bay Trestles Built in Twelve Days .....	24
<b>GENERAL NEWS SECTION .....</b>	<b>25</b>

\*Illustrated.

C. D. YOUNG, engineer of tests of the Pennsylvania Railroad, in discussing the report of the committee on mechanical stokers at the recent convention of the Master Mechanics' Association, stated that his road was arranging to make some tests with powdered or pulverized fuel. The preliminary tests are to be made on a locomotive type boiler, but not on a locomotive, in order to obtain data as to the proper size and the kind of burners and the principles governing the burning of powdered fuel. In Mr. Young's opinion, it will be possible to more nearly obtain the high capacities from the power at high firing rates than when coal is burned in its ordinary form. Marked progress is being made in the use of powdered fuel for industrial purposes, including its use in cement mills, and more recently of its application to heating furnaces, and it is expected that this will be followed by its successful application to locomotives. The principal advantages of pulverized fuel are the better and more prompt intermixture of the gas and the air, thus providing a practically perfect combustion and the absence of smoke. This will necessarily be followed by better performance of the boiler and the locomotive as a whole. A large number of attempts have been made to use a fuel of this kind in the locomotive, but without success. Walter D. Wood, in an article in this issue, analyzes the failures that have followed these attempts, and offers suggestions as to how they may be overcome. A difficulty not mentioned by Mr. Wood, but referred to by H. T. Bentley, assistant superintendent of motive power and machinery of the Chicago & North Western at the Master Mechanics' convention, is that of carrying the pulverized fuel on the tender. It will probably be necessary to entirely redesign the tender to provide for its successful handling. It is finer than soot, if that is possible, and may have to be carried in air-tight containers. Its storage at the coaling stations and its transfer to the tenders offers a complicated problem which must be solved after its use in the locomotive firebox has been demonstrated a success. Its extended use for industrial purposes has again attracted attention to its possibilities for a locomotive fuel and it is understood that experiments will be made by other roads in addition to those which are planned on the Pennsylvania.

THERE is a growing tendency among wide-awake railway executives to find out some of the reasons why railways are not as popular as they might be. One railway president has recently adopted a rather novel way of satisfying his curiosity on this subject. His son's room-mate at college, on the lookout for a remunerative occupation during the summer vacation, applied to this railway president. He was promptly given a job which appeared so "soft" that he almost hesitated to accept it. He is paid \$85 a month, and his instructions are to ride up and down the railroad wherever he pleases, get on and off trains wherever fancy suggests, but to keep his eyes open and report to the president by letter whenever he observes anything in connection with the operation of the road which, from the standpoint of the traveling public, seems inexplicable or wrong. If he hears criticisms of the dining car service, or notices dirty, poorly kept stations, or receives discourteous treatment from employees, or observes any of the little things incident to a railway journey that so often leaves the traveler with a feeling of resentment, he is to sit down and write the president a letter about it. Likewise, if he receives unusually courteous treatment, or notices instances of conspicuously good service, he is likewise to write the president a letter. Every railway, of course, receives reports from its own officers and employees on such matters, as well as many criticisms from patrons. But railway men do not always view such things from the standpoint of the public, while many of the complaints received are written by habitual kickers, who frequently blame the railway for the results of their own negligence, or fail to appreciate the conditions, thus making their statements useless without an independent and often futile post mortem investigation. The young college man, in his personification of the general public, will, in the circumstances, hardly start out in a captious spirit,

or with any preconceived prejudice against the road, and while probably unsophisticated as to the technicalities of railroading, he will naturally be sufficiently impressed with a sense of responsibility to refrain from making criticisms without having been careful to ascertain the facts and conditions. If he is at all observing the information he will collect will yield a handsome return on the investment involved.

**N**O amount of attention or study seems to be too great in deciding upon the details of construction or design of equipment, or the methods of operating a railway. While they are important and need this attention, it is of far greater importance that the selection of men and the placing of them where they can be used to the best advantage be given the proper consideration. Suppose, for instance, it is necessary to promote or transfer a foreman, or that for some reason he is unable to attend to his duties; how is his successor chosen? Are there any scientific records to be consulted which will assist in selecting him, or is he chosen on the spur of the moment and possibly on the basis of some spectacular piece of work which he has recently done? Very often this is the case. Very often also the results are discouraging, for the man may lack in executive ability or in other qualifications, which are vitally necessary to the proper performance of his duties. A number of years ago Le Grand Parish inaugurated a scheme on the Lake Shore & Michigan Southern, by which it was possible to get a record of the personal characteristics of each man in the mechanical department and to follow him up so that if improvement was not made in those features in which he was deficient, his superior officer could be called to account for not having given him a proper amount of attention, or, if it was not the fault of his superior, the man could be called to account, and if advisable eliminated from the organization. The way in which this was done is described in an address, reproduced on another page, which was made by George M. Basford before the recent annual conference of the apprentice instructors of the Santa Fe. This same scheme has been used with excellent results in other industrial organizations and is deserving of the most careful consideration on the part of all industrial managers and railway officers. Too little attention has been given in this country, not only to the selection of workmen and their promotion to more important positions, but also in the assignment of the men to the classes of work for which they are best fitted. Men who would make splendid workmen on certain classes of work in an office or in a shop, have fallen down miserably and made failures because they were used upon an entirely different class of work in the same office or in the same shop, when they might just as well have been properly placed, had those in charge stopped to analyze their mental and physical characteristics before assigning them to their duties. More attention has been given to this feature in European countries and many industrial managers in this country are awakening to its importance. It is a new science and must be developed just as have been certain systems of management and railroad operation, which have been introduced within recent years and have become important factors in the efficient and economical railway management of today.

**W**HY railway men take to rest cures or go into other businesses is illustrated by the experience of roads traversing the states of Arkansas and Oklahoma with the vital question of regulation of screens for passenger coaches. The Arkansas legislature at its last session passed a law requiring the railways to equip their passenger cars from May to November with wire screens at each window, and to keep the same in good repair. A fine of \$10 to \$25 per car per day was provided for failure to comply with the law. The act "being," as it set forth, "necessary for immediate preservation of the public peace, health and safety, and an emergency being deemed to exist," went into effect on May 1. There are a good many flies and mosquitoes in Arkansas; but the Solon who drew up the bill apparently forgot that the same emergency applied in the case of those that might

fly in the doors and ventilators, which the law does not require to be screened. Perhaps he was more concerned with regulating the railways than with regulating the flies and mosquitoes. One railway, whose main lines cross the state in such a way that it had to equip practically all of its coaches, complied with the law in good faith at an expense of some \$6,000. After having been in service only about two months, nearly a third of the screens have been destroyed by passengers. The passengers object to them because they think they interfere with ventilation; and they prefer ventilation to the "public peace, health and safety." And the Corporation Commission of the adjacent state of Oklahoma is apparently of the same mind. For it has issued a proposed order, to be considered at a hearing on July 1, prohibiting the railways from operating cars in that sovereign state that have screens on their windows. Under the recent Supreme Court decisions it would probably not be construed as an undue interference with interstate commerce if the flies and mosquitoes that entered the cars through the doors and ventilators in Arkansas were liberated through the windows in Oklahoma. What the railways that run interstate trains between Oklahoma and Arkansas would like to know, however, is what they are going to do if the Oklahoma commission finally prohibits the use of screens. Must they stop all trains at the border and take off the screens when they are going into Oklahoma, and put them on again when they are going into Arkansas? And if so, if a train is longer than the width of the state line, how are they going to keep from violating the law in both states. Under the Arkansas law the screens must be kept on until after a train has crossed the state line from Arkansas into Oklahoma; but if they are kept on until after the train crosses the line that will be a violation of the law in Oklahoma. A situation will thus be created similar to that proposed by the Kansas legislator who recently introduced a bill requiring that when two trains met on different tracks at crossings, each should stop until the other had passed. If this sort of thing keeps on until railways are required to make complete changes of equipment as well as rates at state lines, one of the problems encountered in physical valuation will be solved. The state of South Dakota, for instance, would then find it much easier to ascertain its proportion of the value of equipment used in transcontinental trains, as well as to prove that it is discriminated against in the assignment of parlor cars.

#### THE SIGNAL MAINTAINER.

**"T**HE man behind the gun," in the signaling world is the maintainer. To the degree that he is intelligent, well trained and conscientious, in the same measure is the service efficient—if there is a sufficient number of him. In maintenance of signals, as in operation of trains, a large proportion of the failures reported are due to faults of men. The supervisor naturally seeks the best men that can be found. Doing this, he must, if he is going to succeed, be supported by a strong management. The question goes right up to the general manager. Seeking the best men means, not merely that reasonable wages shall be offered and fair conditions of work provided for, but that a sufficient force shall be educated. For work on railroads in rural districts, the candidates who are in many respects most satisfactory are young men who have been brought up on the farms or in the villages along the line. But to secure from this class a satisfactory force of signal maintainers it is necessary for the railroad officer to offer apprenticeships which shall be attractive to the country boy at such an age that he can be thoroughly trained in the service, so as to be well prepared at the proper age to assume the duties of a responsible position. While on many roads the practice in this matter is commendable, it must be said that there is far too little of it. Statements of signal supervisors that their maintainers are "rovers," or that it has been found difficult or impossible to get satisfactory men, are common.

In an editorial in our issue of June 13, the work of the maintainer was briefly touched on, in connection with an abstract of signal performance records of the Baltimore & Ohio. That

the position is an important one is a point which needs no argument. On a road like the Baltimore & Ohio the maintainers, almost without exception, give evidence of entire competency. But by far too large a proportion seem not to think much of preparing for promotion to higher responsibilities. A considerable share of the maintenance force in any signal department ought to be men sufficiently studious to fit themselves for advancement as new men are needed in the supervising places. Where the country boys available along the road do not measure up to this standard the railroad officer has got to secure graduates from technical schools, to be trained by doing actual work in subordinate places. This is his only adequate resource. These should be employed in sufficient number to enable him to at all times keep a full force of well qualified supervisors, assistant supervisors and foremen of maintainers. That the keeping of well qualified maintainers is not always an easy task is sufficiently indicated by the record of three months' discipline for a variety of offenses and delinquencies which was given in our article February 21, which record is not different in its general character from that on some other roads. The gravity of the maintainer's responsibility is obvious. By his neglect a signal may give a false clear indication; but by the law of chances, judged by past experiences, *probably* no collision will follow. Then his negligence may go undetected. He must, therefore, have the force of character to do his best without being checked by his superior. Thus, each maintainer, working along the line by himself, with his supervisor many miles away, is under a temptation to relax vigilance, because the liability to dangerous results from negligence is so remote. And if his lack of vigilance, or inefficiency of any kind, does produce a dangerous condition, and the fact is known, still he may be tempted to falsify his report for the purpose of concealing a defect for which he is responsible, and presumably censurable.

The question whether maintainers are sufficiently vigilant in guarding against dangerous failures being, therefore, one which is most difficult to settle, the assurance of the signal engineer that the maintainer is vigilant in all his duties must be based mainly on the engineer's knowledge concerning the records of the much more numerous non-dangerous failures, and how the men deal with them; and concerning the moral character and general behavior of the maintainers.

An important element in the education of maintainers, and in maintaining a high moral standard is the regular holding of conferences by the signal engineer with his supervisors and maintainers, as often as every one or two months. A number of the most enterprising signal engineers have established these institutions and they report highly satisfactory results therefrom. In view of the isolated character of the maintainer's work and the importance of honesty as one of the elements in his qualifications for his position, conferences are to be looked upon as a necessity. Mutual confidence between him and his supervisor is a vital feature if the superintendent is to have at all times the assurance that his signal system is being kept up to the highest standard of efficiency; and this can be secured only by free and frank intercourse.

In connection with the subject of conferences mention may be made of an experiment with records which has been tried to a limited extent, namely, a monthly statement, sent to all the men, in which the records of the different maintainers are set forth in the order of their excellence. With this arrangement, the most efficient maintainer may stand at the head of the list for many months in succession. One signal engineer reports this scheme as satisfactory; emulation is stimulated. Others, however, say that the result is the other way; the comparisons discourage some of the men. It is much to be desired, therefore, that those who have tried this scheme shall report their experience.

The whole subject of the maintainer and his work is worthy of thorough study. What with new types of apparatus, adverse conditions due to rain, frost or snow, and the difficulties in-

herent in the delicate character of the functions of signaling appliances, he is often confronted by problems which routine instructions do not cover and in which he is successful only by reason of native ability and cultivated ingenuity. On the Baltimore & Ohio, when a maintainer discovers and cures an obscure fault in the operation of a mechanism he is likely to receive a congratulatory letter from his superior officer. For reasons suggested in our former article, we are not setting up the Baltimore & Ohio as a model to be emulated by other roads for, not having made careful studies on other roads, we do not know how many of them have already a signal administration which is just as good as that on the B. & O.; but congratulatory letters may be warmly commended to every one, on general principles. Even if some exigency, or precedent, or prejudice should forbid the sending of such a letter, after it had been written, the time spent would not have been lost; the mere writing of such letters is a valuable education to the man who writes them!

The quality of maintainers' minds and consciences, as a subject for discussion in the Railway Signal Association, might well supplant, for a time, the dimensions of the bevel on binding posts and questions of sixty-fourths of an inch in the diameter of switch rods.

#### THE PROPOSED INVESTIGATION REGARDING RATE ADVANCES.

THE Interstate Commerce Commission's denial of the petition of the eastern railways for a reopening of the old rate advance case, No. 3400, is about what the carriers should have expected in view of the difference between their present request for a 5 per cent. horizontal advance and the nature of the advances formerly sought. The commission's announcement of a general investigation as to whether present rates of transportation yield adequate revenues to the carriers in Official Classification territory, and, if not, as to what course they may adopt to deal with the situation, is entirely satisfactory to the railways, as indicated in a statement given out by President Willard of the Baltimore & Ohio. The railways were not so anxious to have their case treated as a revival of the former one as to get it before the commission without the necessity of spending some \$250,000 for the preparation of new tariffs with no assurance that the expenditure would serve any useful purpose. As Mr. Willard observes, the proposed investigation by the commission will afford both the railways and the shippers ample opportunity to be heard on the question of the sufficiency of the existing rates. In its former decisions in the rate advance cases the commission said that if its expectations as to the earnings of the railways proved unfounded, and conditions changed, it would reconsider the question. It now states that it is "of the opinion, from a consideration of the allegations of the petition, that the need of and justification for additional revenue should be at the present time further examined." This is all that the railways ask. There seems no ground for feeling that determination of the matter has been delayed by the form of the commission's order.

The commission undoubtedly has the power to conduct any kind of an investigation of the matters under its jurisdiction that it cares to. Commissioners Clements, Marble and McChord, in their dissenting opinions, indicate some doubt as to the value of such an inquiry as that proposed. They take the ground that the commission should not approve of increases in rates before they have been filed and shippers have had an opportunity to attack them. But the shippers will be afforded full opportunity by the investigation to present any arguments or information in reply to the claims of the railways that they see fit. Nor is there any indication that they will be in any way precluded from subsequently attacking any specific rate or rates that may be filed by the carriers if the commission does render a general opinion that the roads need more revenue.

As Commissioner Clements says, it is not contended that upon such a general inquiry the commission could enter a for-



mal order requiring or authorizing an increase of rates. The commission is not empowered to raise rates or to prescribe minimum rates. But if the commission finds that the present earnings of the carriers are sufficient it will say so and the incident will be closed, except that the railways will still be free to file tariffs at any time advancing such individual rates as they believe they can defend. If on the other hand, the commission sustains the claims of the railways that their earnings are inadequate, and the carriers accordingly file advanced rates, the advanced rates will still remain subject to the legal requirement of reasonableness. Each of them will be open to complaint by the shippers concerned, and the burden of proof as to the reasonableness of the advance of each will be upon the carriers.

It may happen that the commission will hold that the railways should be allowed to earn larger revenues, but that a horizontal advance is not an equitable way of getting them. In that event the commission possibly would signify what kind of advances should be made. This would impose upon the carriers even less of a burden of proof, while that upon the complainants would be correspondingly increased. However, no opinion of the commission and no financial condition of the carriers can render any rate or group of rates permanently reasonable. The carriers could not expect any guarantee that even rates advanced with the express permission of the commission would not be subject in future to attack, and if shown unreasonable, to reduction, whatever the commission may find as to their present necessities. If the commission finds that the interests of the commerce of the country demand the encouragement of transportation development by higher rates, the working out of the details of the way in which advances shall be made will present no great difficulties.

#### A LAW TO PROHIBIT RAILWAY SAFETY.

**K**ANSAS has a new law which provides that any person who shall manipulate or tamper with any switch stand, target, switch light or light controlling the movements of trains, for the purpose of misleading or deceiving engineers, firemen or train crews, shall be deemed guilty of a misdemeanor and fined. There is a further provision that any act in disobedience of this law, which results in death or great bodily injury, shall be deemed a felony punishable by imprisonment. This measure affects all the railways which conduct surprise tests, and effectually puts an end to that very excellent method of determining how well signals are being obeyed.

The surprise test is the railway officer's safeguard against disobedience of signals. It enables him to discover such habitual carelessness on the part of trainmen as would be likely to cause disaster were the signals in their positions of warning under the actual conditions of operation. And although it has held an important place in railroading for many years, it is not as old as the condition it is designed to discover and prevent, for it was not originated until long after the fact was established that carelessness is one of the most common causes of railway accidents. By the aid of the surprise test railway officers have been enabled materially to reduce the number of accidents; and the place of this safeguard in the safety scheme is so well recognized that the Interstate Commerce Commission has gone on record criticizing some railways for not having made more general use of it.

This test introduces no element of actual danger. It merely simulates the condition of real danger which requires the engineer to act. Its only effect upon enginemen is, perhaps, a little inconvenience in making them stop more often than they would otherwise. It is true that it is a form of espionage, but it is an entirely justifiable form, both in theory and because of its actual record of having prevented innumerable enginemen from forming habits of carelessness that would certainly lead to disaster, and of making it possible to weed out those in whom carelessness has become habitual. It has no terrors for enginemen who obey the rules, and it is not a hardship except for such as desire to disobey, and are afraid of being caught at it.

Why a safety measure of such recognized value should be made a crime is not clear unless it is desired to put the men of careless habits beyond the reach of discipline and enable them to disregard signals with impunity. This the Kansas law does. It is to be presumed, of course, that the railways will obey it. But whenever a Kansas trainman is subjected to discipline for having disobeyed a signal he may make the defense that he suspected a surprise test, and chose to disregard the signal ahead because he thought it was an unlawful one. And discipline will, perforce, be but rarely attempted unless operating officers discover some way of finding out just when signals are going to be at stop as the result of actual operating conditions, so that they can be on hand—accompanied by a sufficient number of reputable witnesses to prove that they had nothing to do with putting the signal at stop.

This is one of the worst laws that ever disgraced a statute book. It destroys safety precautions and it is likely to be the means of destroying human lives. It removes from railway operation one of the best assurances of safety, and takes from railway officers one of their best means of enforcing needed discipline.

And why? The legislative committees of the various railway brotherhoods could answer. And the same committees could explain the many full-crew and electric-headlight bills, and most of the other destructive legislation which is rolling an overwhelming burden of unnecessary expense on the railways of this country. There seem to be only two possible explanations of legislation such as this. One is that those who are responsible for it deliberately sell the public welfare in exchange for union labor votes. The other is that their mental condition is such that they ought to be put in a home for the feeble-minded.

#### ENGINEMAN SCHROEDER ACQUITTED.

**T**HAT juries very rarely convict an engineman of manslaughter for causing deaths of passengers or employees is a well known fact. Actual punishment by imprisonment for any great length of time is still more rare. It was not surprising, therefore, that William H. Schroeder, the engineman who figured in the Corning collision of July 4, 1912, was acquitted; but, what is quite unusual, we have in this case a clear and illuminating statement of the circumstances leading up to the acquittal. It is found in a letter in the *New York Times* signed James O. Sebring, assistant district attorney. After narrating the facts, with which our readers are familiar, he says:

The whole blame for the loss of life and the injury to the passengers must forever remain where it rightfully belongs, with Schroeder. The only reasonable explanation of his conduct is that he was asleep; and now, from various sources, there arises the hysterical and unwarranted cry that that acquittal has transferred all the blame from his shoulders and placed it upon that of the management of the railroad company. The verdict represents one more failure of justice. It was not the outcome of the careful or deliberate consideration of the proof, but mainly the result of sympathy for Schroeder, and the efforts of the Brotherhood of Locomotive Engineers and other unions of railroad employees to secure his acquittal. The dismissal of the first indictment and the long delay necessary to bring him to trial upon a second indictment; the recent death of his wife; the long service with the company, and the testimony of six influential citizens of Elmira as to his good character also aided him.

But the principal thing that brought about the farcical verdict was the tremendous and overpowering influence of the railroad employees' unions. The members of these unions were omnipresent in Hornell. They were everywhere. They crowded the Court House; they filled the lobbies of the hotels; they were everywhere upon the streets. They were talking, urging, pleading, and threatening. They worked day and night. They created such a sentiment in Schroeder's behalf that no one could expect that jurors left to roam at will and associate and be with them, could withstand the pressure brought to bear upon them. With such influences surrounding the jury no one could expect a conviction.

No substantial defense was established. Had it been a civil action, the court would, upon the evidence, have been compelled to direct a verdict. It being a criminal action, the court was compelled to leave it to a jury.

We print this as an illustrative instance of the workings of our laws. A man who voluntarily gets into a cab to run a fast train when he knows that his brain is drowsy from drink, deserves severe punishment; all impartial persons will agree

to that. But that convictions for manslaughter have any deterrent effect on other enginemen is more than doubtful. Careful observers believe that the good effect is nil. Moreover, if the prevention of collisions is to be systematically studied, we must go more deeply into the psychology of the question. The influences that freed Schroeder are not so very different from those which play their part in other criminal trials. Extravagant expressions of the sympathy which is ready to forgive the unfortunate are well known to thwart justice in every court. Juries who convict a man of a crime often add a recommendation to mercy. Judges, their minds weighed down by the evils and wretchedness constantly forced on their attention, exercise leniency constantly. They have to do this to preserve their humanity. The administration of cold and rigid justice encounters obstacles at every turn.

It appears that the jurymen at Hornell were permitted to mix with the crowd during nine days. This looks like culpable disregard of an elementary precaution; still, it is very unlikely that the result would have been different if the jurymen had been locked up. The simple plea that the punishment is too severe for the offence has carried the day in hundreds of trials. Chairman Stevens, of the New York State Public Service Commission, a lawyer who has had long experience as a prosecuting officer, says that juries will not convict of manslaughter unless they believe that the accused man meant to kill somebody. The true cure for negligence in the cab is just what it was before criminal trials were ever thought of: patient carrying out of those means, well known to railroad officers, which are calculated to make all of the enginemen as intelligent, conscientious and reliable as are the best and most efficient men in the force.

This course is logically necessary, even if one were to pin his faith to automatic train stops, for there is no excuse for low standards of personal character or weak discipline, however perfect may be the mechanical accessories which are provided. Indeed, one of the best things that can be said of the automatic stop is that it makes runners careful.

#### NEW BOOKS.

*Steel Designing.* By Edward Godfrey, structural engineer for Robert W. Hunt & Co. Size, 4 in. x 6 in.; 492 pages; illustrated. Published by the author, Monongahela Bank Bldg., Pittsburgh, Pa. Price, \$2.50.

"Steel Designing" is the third of a series on structural engineering, the first book being devoted to tables and the second to concrete. The author states in his preface that it is the object of the book to set forth sound engineering in steel design. It is intended to reach not only the designer but the student, inspector and consulting engineer. One feature of the book is a collection of 150 drawings illustrating designs of various classes of structures, which were taken from descriptions in current magazines. A set of definitions of terms used in steel design and erection is included and a complete set of suggested specifications for structural work is added.

*Poor's Manual of Public Utilities.* Published by Poor's Railroad Manual Co., 535 Pearl street, New York. Price, \$7.50.

This is the initial annual number of this Manual of Public Utilities. The fact that it has been compiled and is being published by Poor's Railroad Manual Co. gives it, of course, a very considerable degree of authority. It is the only manual devoted entirely to statements of public service corporations, and the publication of a book of 1924 pages, devoted entirely to street railway, gas and electric light, water power, telephone and telegraph companies, is evidence of the number and importance of such corporations and of the large number of investors who have become interested in their securities. The manual gives figures for about 8,500 corporations, which is probably nearly every corporation performing what may be called public utility operations in the United States. The balance sheet and income accounts of the more important companies are shown not only for the current year but comparative figures are also given which add very greatly to the value of the manual.

## Letters to the Editor.

### THE "CONCILIATION COMMITTEE"—A NECESSITY.

BALTIMORE, Md., May 26, 1913.

TO THE EDITOR OF THE RAILWAY AGE GAZETTE:

The energy displayed by the national and state legislatures to regulate the management and operation of the railroads under the guise of a public necessity, although such legal regulations entail the expenditure of considerable money which might be converted to the improvement of the railroads, has given birth to the idea of organizing and maintaining a so-called "Conciliation Committee."

The primary object of this Conciliation Committee, which would be supported by the railroad as any other official branch of its business, would be to "swing the pendulum" of harmony between the government and the management, and incidentally keep in touch with and awaken the employees to the legal responsibilities of their railroad in order to prevent the payment of heavy penalties for neglect in carrying out the demands of the government.

To plead that every railroad of consequence has a well organized legal department whose duty it is to keep the officials informed of the legislation bearing on their corporate powers is no bar to the action that will undoubtedly be taken by the management in the early future to organize and maintain the Conciliation Committee. I venture to say that the sphere of this committee will be broadened and become so important as to be valued for more reasons than one, for its principles and duties will dovetail the various branches of railroading. It will also relieve the legal department of duties that are now only incidental to the proper interpretation of the law and the legal protection of the rights and franchises of the railroad.

When the Conciliation Committee idea will become a live issue will depend upon the wisdom of the men who are at the helm in fathoming the destiny of the railroads and who will have to contend with new problems as a result of the present valuation work where it has been analyzed by the Interstate Commerce Commission.

The personnel of the Conciliation Committee should be made up of representatives from the various departments of the railroad, and the chairman should be qualified to pass judgment on such matters as ordinarily require unusual tact, experience, reputation for honest convictions and an unbiased intellect. Favoritism in the selection of the personnel of this committee should not be a factor, but every effort should be made to create and maintain harmony among the members as an example for the many employees of the railroad whose opinions should be heard and acted upon for the best interests of the railroad company.

By holding periodical meetings at various points on the line of the railroad, and calling these "get together" meetings primarily for the intercourse of employees, with a limited talk by one of the committee who shall explain the responsibilities of each employee toward his employer and the company toward the government, will, I am sure, accomplish greater good than by simply directing the various department heads to follow the letter of the law without making a special effort to see that these regulations are carried out by the employees. The management sometimes never learns of an infraction of the law until the company is penalized for a violation that could have been prevented had the proper precautions been taken to see that the men in the field had complied with the request of the management through the department head.

An advantage also to accrue from the periodical meetings of employees is to make them better acquainted with one another and by learning their individual views as regards the solution of problems immediately arising in their own spheres of endeavor, the management could, through the intercession of the Conciliation Committee, accomplish the harmonious working that means so much to the welfare of the company.

The key note of the whole situation is the necessity of the management getting closer to the employees of the company—the men whose actions count for so much and whose opinions are sometimes worth a volume of theory—and by practicing a fair policy in instructing the man who makes his living by physical exertion, and he who depends on his mental faculties to help earn for him a comfortable living, it will be possible to accomplish all that is intended by the organization and maintenance of the Conciliation Committee.

CHAS. C. SCHNATTERBECK.

#### GOVERNMENT OWNERSHIP IN ALASKA.

AMARILLO, TEXAS, June 15, 1913.

TO THE EDITOR OF THE RAILWAY AGE GAZETTE:

In an editorial in your issue of May 23 you covered the question of government ownership in Alaska very clearly and should create a great public interest in the subject.

How many members of the commission appointed to investigate the subject have been over the routes recommended, know Alaska or have had extensive experience in such work? It is doubtful if they had reports of surveys and proper data to justify their recommendations. There is a suspicion that they were too anxious to get their recommendation before Congress in order to comply with the party platform.

They propose a cost of \$35,000,000 at first. This sum is one-half the estimated income tax for a year, which has heretofore been considered an emergency tax, and as the advocates of government railways propose cheap rates we can be sure that the privately owned railways and tax payers of the states will be taxed to build these Alaska roads and later to operate them.

We know nothing about the traffic possibilities, but from reports of government prosecutions of interests that have attempted development there, and of the restrictions and requirements imposed on mining and timber business it would appear that development would be very slow and that earnings will be light and the deficit made good by taxation of the states.

A sure and reasonable proposition is to guarantee the interest on bonds of short lines from the coast and aid them by liberal requirements in the development of business. But the essential thing is to place the authority and responsibility for the location of the lines in the hands of men of experience and competence and eliminate all theorists and politicians.

The main point is, there is no right or justice in taxing the Texas farmer to build and operate railroads as an experiment in Alaska.

AVERY TURNER,  
Vice-President Southern Kansas Railway of Texas, Pecos & Northern Texas Railway, and Pecos River Railroad.

#### THE RELIABILITY OF AUTOMATIC BLOCK-SIGNAL RECORDS.

WASHINGTON, D. C., June 16, 1913.

TO THE EDITOR OF THE RAILWAY AGE GAZETTE:

Your articles reporting performances of automatic block signals, published in your issues of February 21 and June 13, have been read with much interest. Some operating officers are making comparisons that they never made before. The different bases on which results are tabulated, and the suggestion of imperfection in the records are points on which your comments are very brief. This is a matter which it is to be hoped will receive further discussion. To some readers the query arises whether these figures, showing such varied results, may not be looked upon as confirming the opinion, held by certain prominent signal engineers, that, because of negligence on the part of the men who should make reports, signal performance records are in many cases unreliable. The claim has been very definitely put forth that enginemen do not carefully report all failures, that maintainers successfully conceal faults for which they themselves are responsible, and that officers, not fully appreciating

the importance of a high standard of efficiency, knowingly tolerate this loose practice. How generally does this idea prevail? Insofar as it has a reasonable basis of fact, there should be a demand for a thorough airing. Automatic block signals are now generally recognized as a vital element in the safety of travel and the public interest in them should be intelligently satisfied. If railway officers are to go on indefinitely in a course which seems to put dependence for safety in part on good luck there will be ground for regret that the Block Signal Board was allowed to die. Something may happen to show that governmental investigations are a good thing. For the present the government has no experts at work; it is the duty of the railways as a body to do the expert investigating themselves. Is not this a fair proposition? Do not the signal engineers of the country, and the operating officers who share with the signal engineers the responsibility for this feature of railroad work, desire to see the whole truth of the situation, as regards the efficiency and safety of American railroad signaling, clearly set forth, for the benefit of all concerned?

P. B. W.

#### AN EARLY LOCOMOTIVE FAILURE.

WINNIPEG, MAN., June 23, 1913.

TO THE EDITOR OF THE RAILWAY AGE GAZETTE:

With reference to the article in the *Daily Railway Age Gazette* of June 16, giving particulars of tombstones at Bromsgrove, England, it may interest you to hear that there was, a few years ago, a tombstone in the churchyard at Whickham, a few miles from Newcastle-on-Tyne, on which are lines almost identical with those quoted by you. I saw this tombstone in March, 1881, and copied the inscription at the time, and for all that I know to the contrary, it may be standing there still, as it was then in a fair state of preservation. You will note that this was erected in memory of an engineer who was accidentally killed a few months previous to those referred to by your article. The inscription as I saw it runs as follows:

"Erected at the expense of the workmen on the Newcastle and Carlisle Railway to the memory of Oswald Gardner, locomotive engineman, who unfortunately lost his life on the above railway near Stokesfield station, from the connecting rod of the engine breaking on Saturday, the 15th day of August, 1840. He was 27 years of age, and was much esteemed by his fellow workmen and by all who had the pleasure of his acquaintance." The following epitaph was composed by an unknown friend to commemorate his worthiness, and left at the Blaydon station:

"My engine now is cold and still,  
No water does my boiler fill,  
My coke affords its flame no more,  
My days of usefulness are o'er,  
My wheels deny their noted speed,  
No more my guiding hand they heed,  
My whistle too has lost its tone,  
Its shrill and thrilling sounds are gone,  
My valves are now thrown open wide  
My flanges all refuse to guide,  
My clacks also, though once so strong  
Refuse their aid in the busy throng,  
No more I feel each urging breath,  
My steam is all condensed in death,  
Life's railway o'er, each station past  
In death I'm stopped, and rest at last,  
Farewell dear friends, and cease to weep,  
In Christ I'm safe, in Him I sleep."

A. C. FRITH.

EXTENSION OF ARGENTINE RAILWAY CONCESSION ASKED.—Dr. M. J. Paunero, concessionaire for a railway from Mar del Plata, has applied to the Argentine congress for an allowance of six months for signing the contract and making the guarantee deposit.

# STUDY YOUR APPRENTICE BOYS CAREFULLY.

An Address Delivered at the Annual Meeting of the Santa Fe Apprentice Instructors, Held at Topeka on May 27.

By G. M. BASFORD.

In 1899 the Railroad Y. M. C. A. building at Argentine, Kan., was erected. When completed John Purcell, now assistant to the vice-president, started an evening class for shop employees, which was the first on the Santa Fe system, or so far as we know, on any other system. This class was composed of four men and two boys.

In 1900 Mr. Purcell was transferred to Ft. Madison as master mechanic, at which time he had about 32 apprentices in the shop. He called all the boys into the office one day and had a talk with them about starting a class. None of them took any interest in it; in fact, some remarked they would leave the service of the company rather than join the class. However, he found one or two of the boys were somewhat undecided and bashful and, keeping them after the other boys left, persuaded them to join the class. He arranged with one of the merchants of the town for several sets of drawing instruments, standing good for them until the boys were able to pay for them at the rate of a dollar a month. The class was started with four boys, but after the first lesson the others came to the office and asked to join. In the course of two months the full number—32—were in the school. Mr. Purcell paid the instructor and the rent of the hall out of his own pocket and the school was continued during the winter months while he was master mechanic at that point. His successor did not feel disposed to advance the money to keep the school going. A great many of the boys kept up their drawing work and at the present time eight of them are apprentice drawing instructors at various points on the system, while others have filled positions of master mechanics, road foremen of engines and roundhouse foremen.

In 1903 J. W. Kendrick, then vice-president, met the speaker in New York and the latter suggested the establishment of an apprenticeship system on the Santa Fe. Mr. Kendrick in turn took the question up with the superintendent of motive power and Mr. Purcell was asked to accept the position of supervisor of apprentices. He felt that he did not care to get out of the actual shop management and Mr. Thomas, present supervisor of apprentices, was put in charge of the apprentice plan. How well he has executed this commission is known to all in the organization and to many outside of it.

If any one in this world ought to be happy the group before me ought to be, because there is no source of happiness to be compared with that of doing a lasting service for others. You are doing for the shop boys under your charge that which no one ever had the opportunity to do before. I wonder whether you fully appreciate this and whether you occasionally stop to think of the possibilities and responsibilities of your position.

Human history reveals the fact that it is usually the boy who springs from humble sources upon whom the greatest responsibilities are placed and to whom the greatest possibilities are brought. You may have in your classes boys who are to take great positions and who are to become great leaders, who are to provide solutions for some of the most difficult problems that men were ever called upon to solve. Do you ever think of this? Do you occasionally stop to think of the possibilities of the inspirations which you may be able to put into the minds of those lads whose educational development is placed in your hands? Everything depends upon the quality and quantity of inspiration which a boy may acquire and it is your privilege in a large degree to inspire your boys with that which will lead them to become truly great men. Stevenson has said: "An inspiration is a joy for ever, a possession as solid as a landed estate, a fortune which we can never exhaust and which gives

us year by year a revenue of pleasurable activity. To have many of these is to be spiritually rich."

I do not mean that it is necessary to be prominent in order to be great; a truly great man is one who completely fills the place in the world which his knowledge, capacity and ability fit him to fill. A great leader is successful only when the ranks of his followers are filled with men who themselves are great in the sense of completely filling the places for which they are fitted. Comparatively few leaders are required, but many trained followers are necessary to the success of any large undertaking. If you develop many good followers you will find that the problem of leadership solves itself.

We often hear of the lack of leaders, of foremen and superintendents. This is not our problem today. If we produce many good men from the ranks those having capacity for administration will reveal themselves automatically. They may not be kept down, they will stand out prominently and will take their proper places. Do not worry about them. Even if you should try to hold them back, they will force themselves to the front.

Conditions prevailing in the mechanical trades today concerning the recruiting of the ranks of skilled workmen present a problem which if not intelligently, consistently, persistently and quickly attacked will constitute a national menace, threatening a national calamity. It is impossible to make such a statement too strong to represent the actual conditions. It is the duty of those who understand and appreciate these conditions to leave no stone unturned in the search of ways and means of bringing the facts before those who are in position to improve the situation.

The stupendous growth of the automobile industry reveals the need of doing something to supply the demand for skilled mechanics. No reliable figures are available to show how many men that industry has taken from the older ones, but the number is very large. They have been taken by force, by sheer robbery with no approach to adequate means for supplying the deficiencies the process has left in the older lines of manufacture. The country can not long stand this drain, and others similar in character, if not in extent, without loss that will become irreparable if manufacturers and railroads do not soon wake up to the danger of the situation.

What is needed is apprenticeship—real apprenticeship—and that quickly: apprenticeship such as you are building up on the Atchison, Topeka & Santa Fe. But there must be vastly more of it. This and all other efforts of the kind today constitute a mere drop in the bucket compared with the general need. It may seem to you out of place to make those statements to you, but it is not. These things should be taken home by all of you to inspire you to even greater efforts than you ever have made, so that your work may bring results so positive, so big and so important to your organization as to attract the attention of hosts of others to the necessity of engaging in this great undertaking.

As a nation we manufacture everything else but workmen. We steal all the workmen we can from Europe. We make vast numbers of specialists who can do one single job fairly well, but we cannot steal enough from Europe. We can not make thoroughly skilled workmen from these specialists. We must do as a nation what you are doing as a railway, train a lot of fine young men whom we may safely trust honestly and correctly to manufacture the many things we need. This problem is training—trade training, combined with the intellectual development necessary to a clear understanding of the reasons for

doing the work as it must be done. No better expression of what is needed has ever come to my attention than that of the Massachusetts Commission on Industrial Training in a report made some years ago. Would that every railroad officer and every manufacturer could have this idea forced upon him. That commission said:

"The commission was told at almost every hearing that in many industries the processes of manufacture and construction are made more difficult and more expensive by a lack of skilled workmen. This lack is not chiefly a want of manual dexterity, though such a want is common, but a want of what may be called industrial intelligence.

"By this is meant mental power to see beyond the task which occupies the hands for the moment to the operations which have preceded and to those which will follow it; power to take in the whole process, knowledge of materials, ideas of cost, ideas of organization, business sense, and a conscience which recognizes obligations. Such intelligence is always discontented, not with its conditions but with its own limitations, and is wise enough to see that the more it has to give the more it will receive.

"Manufacturers confidently believe that a system of industrial education wisely planned would tend to develop such intelligence, while it increases technical skill."

Another quotation also should be forced home to the same people. This is from the head of one of the largest manufacturing organizations of the country. It was called forth by a criticism of workmanship and a suggestion of closer inspection of the work.

"There is no denying the fact that there is a constant tendency toward a lower order of skill on the part of our workmen, especially in the machine shop. A first-class mechanic seldom, if ever, applies for work and we have to make our men from raw material such as presents itself at the gates for employment, and I think the time has come when we should employ instructors rather than inspectors in some of the departments. In any event, the matter of maintaining a maximum of efficiency among our mechanics is becoming a very serious one, and while a rigid system of inspection is a step in the right direction, it does not get at the root of the evil."

Hugh Chalmers, whose name is famous in the automobile field, has said: "We have five ever present problems—materials, management, money, merchandise and men. Of these the last is the most elusive."

In engineering we first familiarize ourselves with materials and then with forces. Do we do the same with men? Do we try to fit men to their places as we do materials and forces? Does any manufacturer or any railroad know about men as about materials? What do you think would happen if we studied man as we study metals, mechanics and engineering, if we knew their characteristics, their abilities and their possibilities? We do not analyze men as we do metals. We guess at their abilities to fill certain places and to do certain things. We often guess wrong and yet it is not necessary to guess at all. We cannot measure capacities or capabilities of boys by looking at them. We must develop more scientific and more thorough methods.

Without doubt the most important message in my power to bring you is that of the importance of studying the characters and abilities of your boys in order that you may not be working with them blindly. No greater criticism of our entire educational system may be made than that it treats its raw material in classes without individual study of each member of the class, and yet there are no greater differences than those between the personal characteristics of individuals. You know perfectly well that you will fail if you attempt to teach classes. You must teach individuals. I desire to bring before you the plan which seems to me to reveal the best path to follow in educational work or in the development of an organization, which is the problem you are engaged in solving.

Before he left railroad service LeGrand Parish introduced a

plan for the study of men.\* It contains elements worthy of most careful study with special reference to the problems before you. Mr. Parish worked out his scheme in order to secure information which would enable him to make promotions in his organization with intelligence. It is presented to you in order to show you the value of studies of personal characteristics in your educational work.

Cards, similar to the one shown, were used:

Name .....				
Employed at .....				
As .....				
	Very Good	Good	Medium	Poor
Education .....				
Special knowledge .....				
Experience .....				
Honesty .....				
Morality .....				
Temperance .....				
Tact .....				
Resource .....				
Reliance .....				
Foresight .....				
Appearance .....				
Memory .....				
Energy .....				
Initiative .....				
Persistence .....				
Assertiveness .....				
Discipline .....				
Promptness .....				
Accuracy .....				
System .....				
Organization .....				
Executive ability .....				
Signature .....				
Date .....				

These were issued to officials with instructions that they be filled out concerning subordinate officials. These subordinate officials were required to fill out other cards for the men under them. The cards were issued in sufficient numbers exactly to fill the requirements so that there would be no surplus. No one could keep a copy of any card. In this way the records would be made twice a year, the cards going to Mr. Parish personally for study and for record and for use in improving his organization. Two things were accomplished. First, the head of the department had a record of the opinion of every man by the officer over him; second, the officers were made to study their subordinates and their opinions of those subordinates were checked every six months. Those who made progress and those who did not received the attention that the organization required.

Suppose you put into effect such a study of your boys. Suppose you compare your own opinion with that of the foreman in every case by having the shop foreman make out the cards as well as yourselves, and then suppose you work with every boy to strengthen his weak points, or perhaps you will change his work or his surroundings as a result of this study. Do you not see how much better you could lead them vocationally and educationally? This is being done at the University of Cincinnati by Dean Schneider, with wonderful results.

Consider for a moment the eight hundred boys under your charge. No two of those boys are alike. Their personal characteristics, however, may be classified to a certain extent and these characteristics may be studied with a view of guiding them into that particular field of work for which they are best fitted. The variety of work in railroad shops is great and, therefore,

\*American Engineer and Railroad Journal, December, 1908, page 459.

offers remarkable opportunities for providing for widely varying abilities. You have about 20 different kinds of work in the shop offering opportunities to provide for many kinds of boys who are mechanically inclined. Not all your boys are mechanically inclined. Some of them should be in the clerical or in other lines of effort. The various divisions of railroad work should be studied and the personal characteristics necessary for success in each should be established. Then by knowing the characteristics of the boys you may direct them into their proper places with intelligence.

For instance, suppose you know the requirements for the boilermaker, the machinist, pattern maker, pipe fitter, tinsmith, copper smith, erecting shop man, powerhouse engineer, and all other shop department men, and suppose you know the requirements of the locomotive fireman, engineer, brakeman, round-house man, the clerk and office man. Suppose you know the characteristics of your boys, you will then be in position to know just what to do with each and every boy and will be able to put each and every one into his particular element.

These personal characteristics listed by Mr. Parish will place a patient plodder, having little initiative, in work which requires frequent repetition of the same task. Then it is a question of manual skill which decides what that task shall be. These boys like to have a task given them which they fully understand. Boys who like responsibility desire a task which they do not fully understand, which involves thought and study as to methods. They are impatient of routine, ambitious to do new things and try new methods. They enjoy a problem and wish to be given one to work out without being told how to do it. In the erecting shop or in the millwright department, perhaps later in the drafting room or test department, these boys will find their greatest opportunity. Others show aptitude in directing the work of others. There are numerous opportunities for them in almost every department.

Time will not permit me to go further into detail in this direction, but this problem of placing the boy in his particular element is, as I see it, the greatest one before you. Let me ask you how you yourselves would have profited by such a plan as this? We usually drift from one line of work to another, losing much time, perhaps years, because no one studies and directs us in such a way as this. How many of us have struggled for several years in a job and have had to be "fired" in order to get us out of a line which we had no business to be in! I maintain that you do not need to "fire" anybody who is willing to work. You may discharge a boy for incompetence in the shop and wake up some day to see him president of the road. This may happen simply because you do not study your boy and because you do not discover inherent ability of a kind different from that which you expect to find. This remark is made to give point to the argument, but to find the future president is not your problem. Your problem is to fill the ranks with men qualified to fill them. You have the material and you also have the responsibility of using it.

It is only when we are doing that which we are fitted for and are intended to do that we succeed and are happy. If we are misfits we are sure to be unsuccessful and unhappy. Perhaps you may not have thought of the possibilities of this kind of individual character study. Perhaps you may not have considered this a part of your opportunity and responsibility.

Tomorrow—Who is thinking about tomorrow? As we understand this word and as we prepare for tomorrow, are we to be judged as to the justification of our being on earth. We are now facing social problems more difficult and more complicated than those of the past, and with more at stake than ever was at stake before. Here we have the labor problem, that of the relations between capital and labor. Are we doing out part to solve it? Who is doing anything permanently to improve it? Are we to leave the solution to selfish interests of some kind?

There must always be a large element of unintelligent labor

ready to follow the leader who talks the loudest and talks the most. From these the unthinking majority of the ranks of labor are and will be recruited. But, there is, and will be, the thinking minority in position largely to control the majority. To these we must look for the solution of labor questions from the labor side. These may be trusted to think and to think straight on this difficult subject. Nothing is to be feared from them, but great and good influence is to be expected from them.

While delayed too long already, there is yet time greatly to increase the proportion of the thinking workers and to contribute in a large way to the improvement of the situation. I do not mean that employers should engage in the business of teaching their side of the question to the workers. I mean that those of the workers, who are to be thinkers should be discovered and should be shown how to think straight.

Employers must look to their recruiting systems. Most of them have no system. They take such men as they can secure and then try to fit square pegs into round holes. No wonder that employers and employees are both dissatisfied. Employers must establish apprenticeship, provide training of the hands and must in some way see to it, that the educational development of the mind goes side by side with the training of the hand. One thing more remains. Employers must know their employees. Then the organization must be one in which good men will like to work.

Apprenticeship is on trial. There is much at stake in your enterprise on the Santa Fe. Show by the great success which you will attain that other large organizations must do the same if they would succeed as you are succeeding.

### NEW MONTCLAIR STATION OF THE DELAWARE, LACKAWANNA & WESTERN.

The Lackawanna has just completed new freight and passenger terminals at Montclair, N. J., involving the expenditure of approximately \$500,000.

The passenger station was opened on Saturday, June 28. This station is built in the Grecian Doric style of architecture open-



Interior of Waiting Room, Montclair Station.

ing through a colonnade into a loggia leading directly to the main waiting room and train concourse. The walls are faced with tapestry brick trimmed with marble chip concrete. The roof over the main waiting room is of green glazed tile, while that over the lower portion of the building is of red quarry tile, the same material being used for the floor of the loggia.

The walls of the main waiting room are faced with buff colored pressed brick broken with pilasters and a molded belt course 16 ft. above the floor line. This belt course and the molded brick surrounding the large semi-circular arched windows at each end of the main waiting room are gray in color. The floor is of marble chip terrazzo, harmonizing in color with the walls.

Particular attention has been paid to the ventilation, which is secured by register faces concealed by the trusses and by ventilated ridge tile directly connected through the roof beams with concealed openings in the purlins along the side walls. Illumination is secured by two large semi-circular windows in the ends of the waiting room, while artificial lighting is provided by eight semi-indirect hanging side lamps and four lamps placed on the seats.

Two ticket windows are provided in the side wall of the main waiting room directly opposite the main doors leading to the track

## FREIGHT RATE ADVANCES AND THE INTER-STATE COMMERCE COMMISSION.

The opinion by the commission is in full as follows:

In the summer of 1910 carriers operating in official classification territory filed with this commission schedules making general advances in freight rates. These tariffs were suspended by the commission and an investigation begun.

The carriers attempted to justify the advance on the ground that owing to increase in wages and other operating costs the then rates of transportation did not yield a sufficient revenue. After full consideration the commission held, in February, 1911, that the advances had not been justified, 20 I. C. C., 243, and in announcing its opinion the commission said that if actual results were less favorable than then appeared probable the carriers might again bring this matter to its attention.

The Baltimore & Ohio, the Erie, the New York Central Lines, and the Pennsylvania Railroad system now petition the commission to reopen the case and proceed with its further consideration. They base this petition upon the ground that the cost of conducting their business has exceeded the forecast of the commission so that the results are much less favorable than had been anticipated. They assert that today, owing to in-



General View of Montclair Station and Trainshed.

concourse. The hand baggage and parcel room is placed at one end of the main waiting room, while men's smoking room, ladies' rest rooms and toilets are located conveniently.

The heating of the building is provided for by a boiler plant about 800 ft. from the station, connected with the station by a 4 ft. x 5 ft. reinforced concrete conduit in which the pipes are placed. Telegraph and telephone lines and all electric lighting wires are placed in a separate conduit built into the walls of the steam pipe conduit.

Four platforms are provided, serving six tracks, each platform being 17 ft. wide and 650 ft. long, covered with reinforced concrete canopies for about 350 ft. The entrances to the driveways leading to the station are flanked by gate posts built of tapestry brick and surmounted by electric light fixtures of hammered copper. The driveways and all flower beds are curbed with concrete and the driveways are paved with creosoted wood blocks.

**RAILWAY TO TEQUENDAMA FALLS, COLOMBIA.**—As the Colombian congress has authorized the president to extend the Southern Railway to the falls of Tequendama river, a decree has been issued for carrying out the extension by the railway administration. The entire net income of the Southern Railway will be used for completing this work.

creased costs of operation of various kinds set out in the petition, the net return is no longer sufficient.

The tariffs which were suspended in the original case advanced class rates and certain commodity rates; the suggestion of this petition is that instead of advancing particular rates there should be a general increase of 5 per cent. in all freight rates.

In view of the allegations of this petition the commission is of the opinion that the question of the need of and justification for additional revenue should be further examined by it at the present time. We think, however, that such examination can be made more satisfactorily and more comprehensively in a general proceeding of investigation instituted by the commission upon its own motion than by a further consideration of this particular record. We have therefore determined to deny the petition for a rehearing and have instituted a proceeding of inquiry into the following matters:

(a) Do the present rates of transportation yield to common carriers by railroad operating in official classification territory adequate revenues?

(b) If not, what general course may carriers pursue to meet the situation?

In this connection the commission makes two observations: First. The fact that we have decided to further investigate

this subject must not be taken as an intimation that the commission has reached the conclusion that revenues are inadequate or that rates should be advanced. Upon this question no opinion has been formed.

Second. That the statute gives to any party the right to attack by complaint any rate, and no general conclusion which the commission may reach and announce in this investigation can affect that right.

Upon the hearing of the proceeding of investigation appropriate reference to the former record in this case will be permitted.

Commissioner Clements, dissenting:

The law leaves to the carriers the initiation of their rates, subject to review and correction by the commission upon complaint, or upon inquiry instituted by it on its own motion, and full hearing, with power in dealing with the amount thereof to prescribe for the future only reasonable maximum rates. Nowhere in the law is the commission authorized to fix absolute or minimum rates. It is authorized to suspend pending investigation rates proposed by the carriers, before they become effective, only when such proposed rates have been filed pursuant to the requirements of section 6 of the act, the provisions of which demand specific statement of the rates proposed and that they be filed with the commission and posted at stations of the carriers.

It is not contended that upon a general inquiry by the commission, such as is here instituted, it could enter any order requiring or authorizing an increase of rates; yet this is a proceeding for the avowed purpose, among other things, of inquiring whether the present rates of the carriers afford adequate revenue. In my view any expression of opinion on this question, following a general inquiry of this kind not based upon specifically proposed rates filed according to law, involves a determination of some of the most fundamental and important questions respecting the reasonableness of rates not before us and contemplates the possibility of giving some sort of general sanction to advanced rates to be thereafter filed by the carriers.

Of necessity it follows that, notwithstanding the recognized right of shippers to protest against such proposed increased rates as might in consequence thereafter be filed, the matters that will necessarily be involved upon the filing of such rates and protests will in a measure have been predetermined. This I cannot believe is within the contemplation of the law or was in the mind of Congress when it was enacted.

Commissioner Marble:

I agree that the petition for rehearing should be denied but cannot agree that the investigation should be made in advance of the posting of the proposed increases.

The petition should be denied because no proposed increased rates are now posted at the stations. On a further hearing of the former proceeding, therefore, the questions to be considered would be merely general, and shippers would not be afforded that specific detailed notice of the proposed new rates contemplated by the act to regulate commerce. The posting of such rates is not a merely technical form, but a necessary preliminary to a precise understanding of them by those to be affected. No conclusion that an increase has been justified in any respect whatever should be reached until after shippers have been given the notice provided by law and so called upon to state their views and objections. The commission has no jurisdiction to make rates in the first instance, to direct increases in rates, or to approve rates in advance of posting and filing.

The dissent is based upon the view that the subject matter of the investigation is the propriety of increases in rates and that the above considerations apply to it also.

Commissioner McChord:

While I agree to the general propositions stated by Commissioners Marble and Clements, yet I am of the opinion that it is our duty to make this investigation.

The act to regulate commerce, among other things, provides:

That the commission hereby created shall have authority to inquire into

the management of the business of all common carriers subject to the provisions of this act and shall keep itself informed as to the manner and method in which the same is conducted and shall have the right to obtain from such common carriers full and complete information necessary to enable the commission to perform the duties and carry out the objects for which it was created; and the commission is hereby authorized and required to execute and enforce the provisions of this act. . . . The Interstate Commerce Commission shall have full authority and power at any time to institute an inquiry, on its own motion, in any case and as to any matter or thing concerning which a complaint is authorized to be made, to or before said commission by any provision of this act, or concerning which any question may arise under any of the provisions of this act, or relating to the enforcement of any of the provisions of this act.

In their petition requesting this investigation the carriers say:

Your petitioners are prepared to show that the cost of conducting the business of the carriers has been, and is being, steadily increased by increases in capital charges; increases in wages; increases in taxes; increased burdens imposed by legislative enactment, such as extra-crew laws, employers' liability and compensation acts; elimination of grade crossings either in part or in whole at the expense of the carriers; the installation of various appliances; and in various other respects.

Your petitioners further allege that existing rates are insufficient to afford just and reasonable compensation and return to the carriers and are unreasonably low in view of the value of the service afforded thereunder.

Your petitioners are prepared to show that they should expend large sums of money, aggregating many millions of dollars, for many purposes, among which are enlargements of yards and terminals, additional tracks, block signals, additional shops, improvements in stations, changes and eliminations of grade crossings, new locomotives, new passenger and freight cars, and other equipment; that these large expenditures of money are demanded by existing and future transportation conditions, and must be made if your petitioners are to satisfy the needs of the public for improved and additional facilities.

Your petitioners are further prepared to show that the large sums of money needed for these improvements must be largely provided by the issuance of new securities, and that such necessary capital can not, under existing transportation rates, be obtained except on terms which would be prohibitive or which the carriers generally would not be justified in assuming. The net earnings produced by existing rates are not sufficiently large to furnish that margin of surplus which will afford the carriers the credit necessary to enable them to secure the additional capital required for such necessary purposes, and it is only through an increase in freight rates that this can be accomplished.

These questions are undoubtedly important, and their investigation will at least be a step in the direction of the commission's keeping itself informed. I think we should brush aside all technicalities and take advantage of the opportunity to go into all these matters thoroughly; as to what shall be said or done after the commission has been fully advised is a question reserved for future determination. The order of investigation should issue. (27 I. C. C., 384.)

#### ORDER.

A petition for rehearing having been filed in No. 3400, In the Matter of Advances in Rates by Carriers in Official Classification Territory, praying that that case may be reopened and further considered upon the ground that operating costs have so increased since the rendition of the decision that rates of transportation are now sufficient; and the commission being of the opinion from a consideration of the allegations of that petition that the need of and justification for additional revenue should be at the present time further examined, but that such examination can be best conducted in a proceeding instituted by the commission itself,

It is thereupon ordered that a proceeding of inquiry be instituted into the following matters:

First. Do the present rates of transportation yield adequate revenues to common carriers by railroad operating in official classification territory?

Second. If not, what general course may carriers pursue to meet the situation?

It is further ordered that in the prosecution of this inquiry opportunity shall be afforded to interested carriers and to the public generally to present such facts and arguments as may be desired; that common carriers by railroad operating in official classification territory are hereby made parties to this proceeding and shall be served with notice thereof, and that subsequent notice shall be given to them and to the public generally of such hearings as may be had.



# THE UNION PACIFIC PLAN AS APPROVED.

The Decree of the United States Circuit Court in the Dissolution Case Has Been Filed Approving the Directors' Latest Plan.

The final decree of the court in the Union Pacific-Southern Pacific is as follows:

Section 1. The amended plan is hereby approved in so far, and only so far, as its provisions are embodied in this decree.

Section 2. Defendants having asked permission to exchange 382,924 shares of Southern Pacific stock for 425,472 shares of Baltimore & Ohio stock owned by the Pennsylvania Railroad Company, and it appearing that such exchange would be a substantial step toward the effectual dissolution of the particular combination now before the court it is hereby approved and leave is granted to effect the same: provided, however, that neither such approval and leave or anything contained in this decree shall ever be taken or construed as affecting the obligations, rights or duties under present or future laws of any person or corporation not a party to this clause, nor be taken or construed as an adjudication that any defendant herein has the right to acquire or hold the shares of stock so sold or exchanged, nor as exemption of any defendant in respect of such acquisition or holding from the operation of any law now in force, or which may hereafter be enacted.

In the event of such sale immediate delivery shall be made of the said 382,924 shares of the Southern Pacific, which is hereby directed to have them transferred on its stock books to the Pennsylvania Railroad, and thereupon to pay to the defendant Oregon Short Line Company, on demand, the dividends appertaining to said shares heretofore declared and payable April 1 and July 1, respectively, and the transaction shall be reported to the court within thirty days from the date hereof.

Section 3. The Central Trust Company of New York, hereinafter called the trustee, is made a party hereto, and is hereby appointed to receive and hold as the custodian and depository of this court, subject to the provisions of this decree and to the further orders and decrees of the court herein, all shares of the stock of the Southern Pacific Company which shall be transferred to it as hereinafter provided.

Section 4. The shares of the Southern Pacific held by the Oregon Short Line remaining after above exchange with the Pennsylvania, to wit, 883,576 shares, or the entire holdings if such exchange with the Pennsylvania shall not be consummated within thirty days from date hereof, shall be transferred forthwith to the trustee and registered in its name on the books of the Southern Pacific.

The defendants Union Pacific and Oregon Short Line shall assign to the trustee all dividends appertaining to the shares so transferred which shall have been declared and shall be then or thereafter payable to the defendant Oregon Short Line, or the individuals holding in its behalf as the registered stockholders entitled to such dividends. Such dividends, hereinafter designated as the accumulated dividends, shall be collected by the trustee and held and distributed on the terms and conditions hereinafter provided.

Section 5. Prior to November 1, 1913, the defendants Union Pacific and Oregon Short Line shall offer to all stockholders of the former, common and preferred, registered as such on a date to be designated in the offer and not more than forty days from its date, or to their assignees, the right to subscribe for certificates of interest representing the Southern Pacific shares transferred to the trustee, substantially in the proportion of their respective holdings, with allowance for possible conversion of bonds. The offering shall include all accumulated dividends, appertaining to said shares, and shall be at such price and upon such other terms as the Union Pacific shall determine, except as herein specifically prescribed or as otherwise directed by the court by a subsequent order or decree.

The subscription shall be payable at the time of the subscrip-

tion or at the option of the subscriber, \$25 per share at the time of the subscription and the balance within one year thereafter with interest at 6 per cent.

Neither the Union Pacific or the Oregon Short Line, or any corporation controlled by either, or any person acting in the interest of either, shall acquire by purchase or otherwise any of said certificates of interest.

The defendants, Union Pacific and Oregon Short Line, may cause the sale of said certificates of interest upon such subscription offer to be underwritten.

Section 6. The trustee shall execute and issue certificates of interest representing the shares transferred hereunder and shall deliver them at its office in the city of New York to the subscribers thereof upon payment in full of the subscription price, etc.

Section 7. [Refers to issuance of trustee by part payment subscription receipts.]

Section 8. The certificates of interest and the subscription receipts issued hereunder may be in the denominations of 1 share, 10 shares, 50 shares, 100 shares and such other denominations as the trustee shall elect.

Section 9. The trustee shall, if so requested by the registered owner of any subscription receipt, by application in writing not less than 10 days prior to any annual or stockholders' meeting of the Southern Pacific, execute and deliver to such registered owner a proxy appointing such proxies as he shall nominate to appear and vote at such meetings.

Provided, however, that as a condition precedent to the issue of such proxy the applicant shall file with the trustee an affidavit that he is not the holder of any shares in the Union Pacific.

Section 10. So long as any share of the capital stock of the Southern Pacific shall be held by the trustee, the trustee shall collect and receive all cash dividends declared by the Southern Pacific appertaining to the shares so held. Upon the conversion of any certificate of interest into shares of Southern Pacific stock the latter shall pay in cash to the owner of the certificate converted the amount of all cash dividends collected by it, including the aforesaid accumulated dividends, appertaining to the shares represented by such certificate of interest. Any interest realized or allowed by the trustee upon funds paid to it as dividends shall be applicable to the payment of the compensation of the trustee and expenses, and any balance shall be paid to the Oregon Short Line unless otherwise ordered.

Section 11. At any time, upon demand, upon surrender of any outstanding certificate of interest by the registered owner, the trustee shall deliver to him, stock certificates for the number of shares of Southern Pacific represented, upon condition, however, that the applicant for such conversion shall file with the trustee duly executed affidavit in one of the forms annexed.

[The affidavits referred to are to the effect that the holder who desires to convert his certificates into Southern Pacific stock holds no shares of the Union Pacific Company.]

All dividends payable, otherwise than in cash, which shall be declared by the Southern Pacific shall be received and held by the trustee for the pro rata benefit of such registered owners upon the same terms and conditions as the shares originally deposited.

Provided, however, that whenever the number of shares of Southern Pacific stock held by the trustees shall be reduced to 500 shares they shall be distributed pro rata among the registered owners of the then outstanding certificates of interest.

Within thirty days after conversion of certificates shall have commenced, and at monthly intervals thereafter, the trustee shall file with the court a report showing the aggregate amount con-

verted since the last previous report and the names of all persons to whom Southern Pacific stock shall have been issued pursuant to every such conversion involving more than 100 shares; and from time to time at the request of the attorney-general the trustee shall furnish him with any information he shall require relative to the carrying out of this decree.

Section 16. Nothing in this decree shall be construed as prohibiting the Union Pacific from acquiring at any time the capital stock or other property of the Central Pacific.

Section 18. The trustee is hereby authorized to treat all funds on deposit hereunder as general deposits and to allow interests thereon. L. C. Krauthoff, of New York City, is appointed commissioner for the court to see to it that the letter and spirit of this plan of dissolution is carried out and is directed to report to the court from time to time.

\* \* \*

In his response to the petition, the attorney-general gives these reasons for approving the exchange plan for the disposal of \$38,000,000 of the stock:

The proposed sale to the Pennsylvania Railroad of 382,924 shares of the capital stock of the Southern Pacific now owned or controlled by the Union Pacific in exchange for 425,472 shares of the capital stock of the Baltimore & Ohio Railroad, now owned by the Pennsylvania, obviously goes far to separate the Southern Pacific from the Union Pacific, and to that extent breaks up the particular unlawful combination between them asailed in the original bill. Moreover, it divests the Pennsylvania Railroad of a large amount of the capital stock of an active competitor and thereby remedies a highly objectionable condition. So far as I am able to ascertain such exchange would not result in creating any new combination in restraint of trade, nor any other condition in violation of existing law.

The attorney-general, however, qualifies his approval of the exchange plan with the suggestion that a proviso be added specifically reserving to the government the right to bring action against the combination between the Pennsylvania and the Southern Pacific, or that between the Union Pacific and the Baltimore & Ohio should it appear in the future that any illegal condition, not now anticipated, had resulted from the transactions described; and to Congress the power to enact legislation which may affect these combinations.

Justifying this reservation, the attorney-general says in his response:

"While the lines of the Pennsylvania system appear to be non-competitive with those of the Southern Pacific and the lines of the Union Pacific non-competitive with those of the Baltimore & Ohio, it is manifest that the Pennsylvania lines and the Southern Pacific lines do not connect so as to form a continuous route, nor do those of the Union Pacific and the Baltimore & Ohio.

"Furthermore, while at present no federal law forbids a railroad company from owning stock in another non-competitive line, Congress may hereafter deem it advisable to change the national policy in that regard, and the courts may interpret existing laws so as to give them meanings different from those now accepted.

"Wherefore . . . said exchange should only be permitted subject to the following express condition, in substance:

"That such permission shall not be taken or construed as affecting the obligations, powers, rights, or duties under either present or future laws of any person or corporation not a party to this cause, nor be taken or construed as an adjudication that any party hereto has the right to acquire or hold the shares of stocks so sold or exchanged, nor as an exemption of any such party in respect of such acquisition or holding, from the operation of any law now in force or which may hereafter be enacted.

"Not only would this proviso leave unobstructed the power of Congress hereafter to legislate in respect of the stocks or transactions in question, but if any illegal condition should result

from the proposed exchange of stocks under existing law the government would freely assail it, if so advised."

Approving those sections of the petition which provide for the disposal under a trusteeship of the remaining \$88,000,000 the attorney-general says in his response:

"These provisions put the disposition of such shares under the direction of the court. The trustee has no power to vote the shares except when and as directed by the court. The holders will have no voting rights and will receive no dividends until their certificates are converted into stock of the Southern Pacific, and such comparison can only be made upon affidavit that the applicant owns no shares of the Union Pacific, and is not acting for or on behalf of any stockholder thereof. Further, the holders of such certificates can receive no interest on the dividends collected and held by the trustee.

"At monthly intervals the trustee is required to report to the court the names of all persons, firms or corporations who shall have converted such certificates into shares of stock of the Southern Pacific where the conversions involved more than 100 shares and the attorney-general may require of the trustee any other information relating to the carrying out of the plan.

"These provisions seem well designed to bring about a distribution of the shares of the Southern Pacific unlawfully acquired and controlled by the Union Pacific among persons not stockholders of the latter and thus effectually dissolve the unlawful combination. If they unexpectedly fail the disposition of the stock will remain subject to the further order of the court."

## POWDERED FUEL FOR LOCOMOTIVES.

BY WALTER D. WOOD.\*

Everywhere the demand is for more motive power; every day the problem of smoke is becoming more urgent, and we have about come to a standstill in the development of our steam power. The railroads have been forced to electrify in the large cities; even Chicago, which has held out so long, has about forced the issue to a head, and electrification must come unless smoke is abolished—not partly, but entirely. All sorts of means and devices have been tried to this end, including stokers, so-called smoke consumers, fire brick arches and coal in different forms (coke, briquettes, etc.). Coke is smokeless, but impracticable for reasons of space, cost and low volatile qualities.

Outside of the cities on our big Mallets it has become a question of consistent performance and extra firemen. Practically all of the biggest Mallets have, or have had, stokers of various types at some time or other, most of them having proved inadequate when the most trying conditions were imposed upon them; in some cases they have been taken out entirely and hand firing resorted to, which usually means two firemen and extra expense.

For many years coal in powdered form has been used very successfully and economically in cement mills throughout the country and in several metallurgical furnaces and wrought iron concerns. In the cement mills it replaced oil, proving far cheaper than the liquid, even when the cost of drying and pulverizing is taken into consideration. Besides being from one-third to one-half cheaper than burning coal in the regular form, it is absolutely smokeless. Both of these things recommend it at once for use on locomotives. This appealed to the officers of several roads as long as ten or twelve years ago, and several of them have even gone to the trouble of equipping locomotives experimentally for trying out this method, and each in turn has failed from one cause or another. The purpose of this article is to analyze these trials and show wherein the trouble lies, and in most cases point out the remedy.

The biggest mistake that was made in nearly all the experiments was to try to pulverize the coal on the engine itself. This has proved time and again to be impracticable even in stationary plants where everything was favorable for the best results. The reason this cannot be done is because there is no way of drying

\*Altoona, Pa.

the coal, and again the amount of coal pulverized per second, or minute, by any form of pulverizer, is so variable, according to the size, hardness and amount of moisture that happens to constitute any lump of coal fed the machine, that it is impossible to regulate the supply of air and coal in proportion to suit the varying rate of production. Again, this system limits a flexible supply; in other words a sudden call for fuel (when the engine strikes a grade) cannot be met unless the entire workings of the pulverizer are changed to increase the output one minute and decrease it the next, and this is out of the question. The only practical way to burn powdered coal on a locomotive is to carry it powdered in an air-tight tank, the same as sand is carried in the sand box, and draw it off as needed at the bottom by a screw conveyor or other means.

Another common mistake that was made almost without exception was to blow the coal dust into the firebox with considerable velocity. A locomotive firebox is one thing and a cement kiln is another. The latter is a cylinder 140 ft. long and 8 ft. in diameter. Some concerns blow their coal dust in with 60 to 80 lbs. of air per square inch; most of them use from 6 to 9 ozs. The heat generated by a pulverized coal flame is from 3,000 deg. to 4,000 deg. F.; add to this a high velocity and you have a blow pipe effect that will destroy fire brick and make it run like molten glass. (This temperature, however, can be reduced 800 deg. to 1,000 deg. by using excess air.) This is not so much the effect of the heat as it is of the flame impinging directly against the fire brick.

In the cement kilns the fire brick lasts for months, because the path of the flame and gases is not interrupted, but they can travel straight through and out. In bricked up fireboxes where it has been tried it has sometimes broken down the arch in a few hours. A western road experimenting recently had the beading on the ends of the flues badly burned. In all cases the fault was the same—high velocity. True, to make our boilers steam we must of necessity bring gases containing a certain number of heat units in contact with the walls of their flues. This in turn demands that we must develop this number of heat units every second in the firebox, which in turn compels us to introduce and consume a certain number of pounds of coal per hour in order to liberate this heat. This would be easy if it were not for the fact that we have to supply 150 cu. ft. of air for every pound of coal consumed, and in our big Mallets, where as high as 10,000 lbs. of coal per hour are sometimes required, it means that we must have high velocity to supply this air or else provide an enormous area of supply. In nearly all cases heretofore the practice has been to close up the firebox entirely, including the grate area, and supply all the air through one or two small nozzles about 6 in. in diameter by means of a blower, the coal going in the same way and impinging with terrific velocity in a half consumed state against the fire brick, or whatever else opposed its progress. I say half consumed, because it has not had time to become ignited from the heat of the surrounding walls. The only way to burn it properly and thoroughly at the same time is to blow it into the firebox with only enough air to float it or make a dust cloud (about 1 or 2 lbs. of air per pound of coal is sufficient). The other 12 lbs. of air are supplied by natural induced draft alone, the same as when burning coal on the grate.

Another detail of construction that this method entails is the use of what I call a "duplex" nozzle, or a nozzle within a nozzle, the small inner one supplying the coal dust with just enough air to carry it in, and the larger surrounding one supplying the necessary air for combustion at a pressure so low that the exhaust of the locomotive will create a high vacuum in the firebox. This double nozzle is a proved success and is working every day in the year at a big iron and steel works in the East, producing by far the most flexible and economical feed in existence.

An ideal arrangement for a large locomotive is to have three nozzles, each the area of a fire door, placed just above the mud ring in the front of the firebox with adjustable air control from zero to full open, and directly below them in the grate surface

three more auxiliary air openings, still larger and also having adjustable air control. By this system the entering velocity of the coal dust is reduced to a minimum, and it has time to expand and burn before it is carried into the tubes. When you take into consideration the fact that even in cement kilns where conditions are ideal and with only 8 ozs. of pressure, the coal is blown in 5 or 6 ft. before it ignites, we can see how absolutely essential it is to have a low entering velocity for use on locomotives where the firebox is so small in comparison.

It is well known that we must have fire brick and plenty of it to successfully convert the coal dust into  $\text{CO}_2$ , but at the same time it must be so constructed as to decrease the size of the firebox as little as possible, for of course the entering coal dust and air will expand in proportion to the difference in the outside temperature and the temperature of the firebox. When you take into consideration that a cubic inch of coal when finely powdered (90 per cent. through 200 mesh) offers about 20 sq. ft. of effective area for combustion, it can readily be seen that the area of the firebox is a big factor and unless we have one large enough to burn the rapidly expanding gas (for such it practically is) and draft enough to remove the products of combustion, we will have the gas forcing its way out of the front of the firebox and back through the nozzle, causing a series of puffs, or "back fires." This was actually the case in a series of tests run some years ago where it was tried to feed more coal than could be burned. With sufficient draft and air, however, the danger is nil.

Locomotive fireboxes have staybolts—hundreds of them. These must be inspected regularly; every week on some roads. This makes bricking up the walls of the firebox prohibitory—but we must have the fire brick. One possible solution is the Jacobs-Schupert or stayless type of firebox with its entire circumference bricked and a Scotch marine type of return boiler. The writer has worked up such a design, having the exhaust stack over the cab. This would leave the front end entirely free for unlimited superheater and feed water space, and would be a highly efficient boiler. One somewhat similar in design to this was tried out on the Manhattan Elevated Railroad some years ago and proved wonderfully efficient from the boiler end, but failed in the method of firing the powdered coal. Another alternative is the "tube firebox," i. e., a firebox constructed of tubes embedded in fire brick and connecting upper and lower water legs; also a well protected arch with double the number of tubes to keep it cool. This would go on in place of the present firebox and would take up the same amount of space, and the circulation would be enormous in comparison with the present type. The Scotch marine return tube design would also be carried out in this boiler. It has been proved by experiment and practice that pipes embedded in the brick will protect it. It may frit and chip off to a certain extent, but when the area of protection is reached it stops.

One other thing has caused a world of trouble and the failure of more than half the trials, and that is slag. In most tests where it was tried to get rid of it, it was found that although plastic when the furnace was in operation, it would cool before it could be gotten out. Brick doors and all sorts of schemes have been tried without success. The writer has devised a simple arrangement by means of which the slag is taken care of as fast as it is formed, doing away with all trouble of trying to rake it out, etc. Roughly it is to have the fire brick at the bottom slope toward the middle and one end and open at the center so that the slag will drop into a dumping pan of water and crystallize. It can then be dumped on the track or at the ash pit. The dumping pan can be filled with water from the injector overflow. The induced draft will allow the use of an open bottom firebox.

As to fineness; the coal should be 95 per cent. through a 100 mesh screen and 85 per cent. through a 200 mesh, and it should not contain over 5 per cent. of free moisture. The cost of pulverizing, drying and storing the coal is more than outbalanced by the many economies effected. There is a direct saving of

one-third of the coal through more perfect combustion, a saving by the abolition of ash pits and cleaning gangs, a direct saving in the ability to cut off the fire at will while standing in stations and on sidings, a saving in property values and paint on rolling stock through absence of smoke and cinders, etc. Added to all this is the wonderful flexibility of the fire, the supply of coal and air being increased or decreased at will by the turn of a valve. In switchers and other small engines a fireman would be superfluous. Coal, the analysis of which showed 50 per cent. of ash, has been burned by powdering it and blowing it in a furnace. This opens up for use a grade of coal which hitherto has been practically valueless. Powdered fuel is coming, and it is coming as sure as electrification came in New York and other cities. One of our largest locomotive companies at the present time is spending some \$50,000 to adapt powdered fuel to locomotives.

**TRAIN DESPATCHERS' CONVENTION.**

The twenty-sixth annual convention of the Train Dispatchers' Association of America was held at the Alexandria Hotel, Los Angeles, Cal., June 17, 18 and 19, President Kane presiding. The credentials committee reported 71 members present. The president in his annual address reported a gratifying addition to the membership during the past year. The resignations of eighteen members were received and eighty-one applications were presented for membership or reinstatement and favorably balloted upon.

F. R. Anderson, supervisor of signals for the Northern Pacific at Livingston, Mont., read a paper on "Advantages of the Telephone for Train Dispatching," which developed considerable discussion.

On Wednesday the report of the executive committee was read and, with the president's address, was referred to a committee of three for consideration and further report.

The report of the executive committee showed income for the year \$4,008, with increases as follows:

From dues .....	\$631
From application fees .....	221
From bulletin subscriptions .....	314
From sundry receipts .....	4
<b>Total .....</b>	<b>\$1,170</b>

Offset by expenditures amounting to \$4,337.83.

The membership account showed a net increase during the year of 164 members, making the total membership of the association on the first of June 1,108. The 81 members elected and reinstated at this convention bring this total up to 1,189 members.

During the afternoon session of Wednesday brief addresses were made by H. V. Platt, general superintendent of the Southern Pacific; R. J. Clancy, assistant to general manager Southern Pacific; W. H. Whelan, superintendent Los Angeles division Southern Pacific, and J. H. Dyer, superintendent of the Tucson division of the Southern Pacific. These gentlemen made a special trip from Bakersfield in order to be present.

The report of the Train Rules Committee, consisting of a memorial address and submitted to the American Railway Association by the Joint Train Rules Committee of the Superintendents' and Train Dispatchers' Associations, was taken up and discussed during the remainder of the Wednesday afternoon session, and resumed during the forenoon of Thursday. The recommendations on the various rules of the standard code were considered and discussed one by one, and with one or two exceptions were approved.

I. L. Hibbard, acting general manager of the Coast Lines of the Santa Fe; J. R. Hitchcock, acting general superintendent of the same lines; L. M. Jones, superintendent of telegraph of the Santa Fe lines, and Paul Burks, Los Angeles attorney for the Coast Lines of the Santa Fe, were present at the Thursday afternoon session, and each of them addressed the convention.

The final session of the convention was held on Thursday evening and officers for the next year were elected as follows:

President, J. P. Finan (A. T. & S. F.), Needles, Cal.; vice-president, C. A. O'Connor (Boston & Albany), Springfield, Mass.; editor, J. F. Mackie, Chicago, Ill. (re-elected). Jacksonville, Fla., was selected as the next place of meeting, and the date fixed as June 16, 1914.

The program of entertainment was elaborate, and well arranged. There was an auto tour of Los Angeles and suburbs for all delegates and their ladies; a visit to the Cawston Ostrich Farm; a general get-acquainted meeting Monday evening; a theater party Tuesday, and a grand ball Wednesday evening, attended by 350 delegates and members of the local entertainment and arrangement committees, and by a large number of railway officers of Los Angeles. There were also trolley trips for ladies and various other things, but none was allowed to interfere with the conduct of the business of the convention. On Friday after the business was finished there was a complimentary trip, by the Southern Pacific and the Banning Company, to San Pedro and Catalina Island, and the party were entertained at luncheon by the Southern Pacific Company at the Hotel Metropole.

On Saturday there was a scenic trip around the famous kite-shaped track, which was complimentary by the Santa Fe. The delegates and their ladies were entertained at the celebrated Mission Inn at Riverside.

On invitation from the dispatchers of San Francisco a party went to that city for the Monday and Tuesday following the convention. The San Francisco entertainment included the ascent of Mount Tamalpais.

The Los Angeles convention was voted the best attended and most interesting, instructive and altogether delightful convention in the history of the association. All were loud in praise of the hospitality of the dispatchers and of the railway companies. The Santa Fe ran a special train of seven Pullman cars and a baggage car from Chicago for the delegates from the eastern and central part of the country, with a side trip from Williams to the Grand Canyon of the Colorado.

**AMERICAN SOCIETY FOR TESTING MATERIALS.**

The proceedings of the first session of the sixteenth annual meeting of the American Society for Testing Materials were reported in the *Railway Age Gazette* of June 27, 1913, page 1609. At the opening of the business session on Tuesday evening, June 24, Albert Sauveur presented a paper in which was proposed a recommended practice for the heat treatment of case-hardened carbon-steel objects. It was recommended that the following treatments be applied to case-hardened steel objects according to requirements:

When hardness of case only is desired and lack of toughness or even brittleness unimportant, the carburized articles may be quenched from the carburizing temperature, as for instance, by emptying the contents of the boxes in cold water or in oil. Both the core and the case are then coarsely crystalline.

In order to reduce the hardening stresses and to decrease the danger of distortion and cracking in the quenching bath, the articles may be removed from the box and allowed to cool before quenching to a temperature slightly exceeding the critical range of the case, namely, 1475 deg. to 1520 deg. F. Both the core and case remain coarsely crystalline.

To refine the case and increase its toughness the carburized articles should be allowed to cool slowly in the carburizing box within the furnace or outside to 1200 deg. F. or below, and should then be reheated to a temperature slightly exceeding the lower critical point of the case (in the majority of instances a temperature varying in accordance with the carbon content and thickness of the case between 1425 deg. and 1520 deg. F. will be suitable), and quenched in water, or, for greater toughness but less hardness, in oil. The objects should be removed from the quenching bath before their temperature has fallen below 212

deg. F. This treatment is more especially to be recommended when the carburizing temperature has not exceeded 1650 deg. F. It refines the case but not the core.

To refine both the core and the case and to increase their toughness the articles should be allowed to cool slowly from the carburizing temperature to 1200 deg. F. or below and should then be (a) reheated to a temperature exceeding the critical point of the core which will generally be some 1650 deg. F. to 1740 deg. F. followed by quenching in water or in oil; and (b) before they have cooled below 212 deg. F. they should be reheated to a temperature slightly exceeding the lower critical point of the case (in the majority of instances a temperature varying in accordance with the carbon content and thickness of the case between 1425 deg. and 1520 deg. F. will be suitable), and again quenched in water or oil.

In order to reduce the hardening stresses created by quenching the objects, as a final treatment, may be tempered by reheating them to a temperature not exceeding 212 deg. F.

There was no discussion.

STANDARD SPECIFICATIONS FOR STEEL.

In the report on the Standard Specifications for Steel there was included a report on a series of investigations on wrought steel wheels, conducted under the supervision of a committee, in which four wheels were tested to destruction. The details of these tests are given in the following tables which show the great resistance offered by them to the blows delivered by the drop.

TABLE I. RESULTS OF TESTS.

Kind of Test.	Wheel.							
	A	B	C	D	E	F	G	H
<b>M. C. B. DROP.</b>								
Number of Blows.....	12	12	12	12	.....	.....	.....	.....
Inspection.....	O. K.	O. K.	O. K.	O. K.	.....	.....	.....	.....
Number of Blows.....	18	18	18	18	.....	.....	.....	.....
Inspection.....	O. K.	O. K.	O. K.	O. K.	.....	.....	.....	.....
<b>THERMAL</b>					Normal	Normal	Normal	Normal
Inspection.....	.....	.....	.....	.....	O. K.	O. K.	O. K.	O. K.
<b>DOUBLE THERMAL AND QUENCH</b>								
Inspection.....	O. K.	O. K.	O. K.	O. K.	O. K.	O. K.	O. K.	O. K.
<b>M. C. B. DROP</b>								
Number of Blows.....	12	12	12	12	12	12	12	12
Inspection.....	O. K.	O. K.	O. K.	O. K.	O. K.	O. K.	O. K.	O. K.
<b>1640-LB. DROP.</b>								
Deflection, in., after one blow each at.								
5 ft.....	Hub None	None	None	Broke	1/2	None	None	None
	Rim None	None	None	.....	None	None	None	None
10 ft.....	Hub 1/2	1/2	1/2	.....	Broke	1/2	1/2	1/2
	Rim None	None	1/2	.....	.....	None	1/2	1/2
15 ft.....	Hub 1/2	Broke	Broke	.....	.....	1/2	Broke	1/2
	Rim 1/2	.....	.....	.....	.....	None	.....	1/2
20 ft.....	Hub Broke	.....	.....	.....	.....	Broke	.....	1/2
	Rim .....	.....	.....	.....	.....	.....	.....	1/2

DESCRIPTION OF WHEELS AFTER DESTRUCTION.

- A.—Hub punched out. Rim intact. Plate shattered. No sign of previous fracture.
- B.—Broke through rim on both sides about 150 deg. apart, crack extending around plate through punched hole and leaving hub attached to other side of plate. No sign of previous fracture.
- C.—Hub punched out. Rim intact. No sign of previous fracture.
- D.—Hub punched out. Rim intact. No sign of previous fracture.
- E.—Hub punched out and plate shattered. Rim intact. No sign of previous fracture.
- F.—Broke all around plate. Rim intact. No sign of previous fracture.
- G.—Hub punched out. Rim intact. No sign of previous fracture.

<sup>1</sup> The objects should be removed from the quenching bath before they have cooled below 212 deg. F. in order to lessen the danger of cracking, and they should be placed in the reheating furnace while still at a temperature of at least 212 deg. F. likewise to lessen the danger of cracking, it being inadvisable (a) to allow steel to cool completely in the quenching bath and (b) to place hardened steel in a hot furnace. Obviously, if the furnace is cold the hardened steel may likewise be cold when placed in it for reheating.

H.—After blow at 10 ft. there was indication of crack in flange where cast iron had struck it in pouring, which crack, after blow at 20 ft., extended through rim on other side and part way around plate. Test stopped at this point.

The second wheel of each pair was subjected to the M. C. B. standard drop test. It was then examined for surface imperfections and subjected to 18 additional blows from the M. C. B. standard drop (200 lbs. falling 12 ft.). It was then examined for surface imperfections and subjected to the double thermal test and quenched. It was then subjected to the M. C. B. standard drop test, examined for surface imperfections, and tested to destruction with the 1640-lb. drop.

Tabulated results of these tests, together with the chemical analyses, are given in Tables I. and II.

TABLE II.

Wheel	Chemical Composition, per cent.							
	C	Mn	P	Si	S	Ni	Cr	Cu
A.....	0.699	0.624	0.037	0.249	0.038	0.116	0.025	0.100
B.....	0.682	0.689	0.039	0.278	0.030	0.259	0.023	0.085
C.....	0.803	0.586	0.016	0.181	0.026	0.081	0.017	.....
D.....	0.717	0.750	0.021	0.209	0.033	0.038	0.037	.....
E.....	0.714	0.730	0.024	0.104	0.034	0.045	0.037	.....
F.....	0.681	0.663	0.034	0.292	0.045	0.123	0.016	0.135
G.....	0.734	0.708	0.030	0.163	0.028	0.047	0.015	.....
H.....	0.693	0.692	0.040	0.271	0.031	0.284	0.037	0.085

The following proposed new standard specifications for steel were also considered in the report:

MEDIUM-CARBON STEEL SPLICE BARS.

1. Manufacture.

1. The steel shall be made by the open-hearth process.
2. The splice bars may be punched, slotted and, in the case of special designs, shaped either hot or cold; but in the latter case they shall be subsequently annealed.

II. Chemical Properties and Tests.

3. The steel shall conform to the following requirements as to chemical composition:

Carbon.....not under 0.30 per cent.  
Phosphorus.....not over 0.04 per cent.

4. An analysis to determine the percentages of carbon, manganese, phosphorus and sulphur shall be made by the manufacturer from a test ingot taken during the pouring of each melt, a copy of which shall be given to the purchaser or his representative. This analysis shall conform to the requirements specified in Section 3. Drillings for analysis shall be taken not less than 1/8 in. beneath the surface of the test ingot.

5. Analyses may be made by the purchaser from finished splice bars representing each melt, in which case an excess of

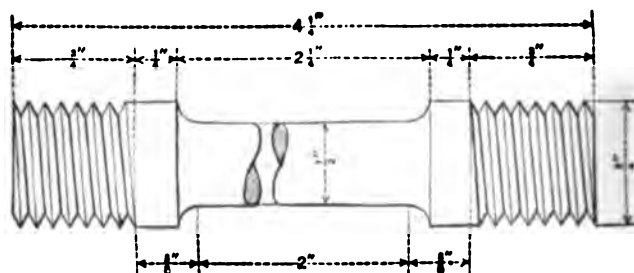

Fig. 1.

- 25 per cent. above the requirement as to phosphorus specified in Section 3 shall be allowed.

III. Physical Properties and Tests.

6. The splice bars shall conform to the following requirements as to tensile properties:

Tensile strength, lbs. per sq. in.....68,000 83,000  
(See Section 7.)  
Elongation in 2 in., min., per cent.....1,600,000  
Tens. str.

7. The tensile strength may be over 83,000 to and including

85,000 lbs. per sq. in., provided that the elongation in 2 in. is not under 20 per cent.

8. The bend test specimen specified in Section 9 shall bend cold through 180 deg. around a pin the diameter of which is equal to twice the thickness of the specimen, without cracking on the outside of the bent portion.

9. Tension and bend test specimens shall be taken from the finished bars. Tension test specimens shall be of the form and dimensions shown in Fig. 1. Bend test specimens may be 1/2 in. square in section, or rectangular in section with two parallel faces as rolled.

10. If preferred by the manufacturer and approved by the purchaser, the following bend test may be substituted for that described in Section 8: A piece of the finished bar shall bend cold through 90 deg. around a pin the diameter of which is equal to twice the greatest thickness of the section, without cracking on the outside of the bent portion.

11. (a) One tension and one bend test shall be made from each melt.

(b) If any test specimen shows defective machining or develops flaws, or if a tension test specimen breaks outside the gage length, it may be discarded and another specimen substituted.

IV. Workmanship and Finish.

12. The splice bars shall be smoothly rolled, true to templet, and shall accurately fit the rails for which they are intended. The bars shall be sheared to length, and the punching and notching shall conform to the dimensions specified by the purchaser. A variation of 1/32 in. from the specified size and location of holes, and of 1/8 in. from the specified length of splice bar, will be permitted. Any variation from a straight line in a vertical plane shall be such as will make the bars high in the center. The maximum camber in either plane shall not exceed 1/16 in. in 24 in.

13. The finished splice bars shall be free from injurious defects and shall have a workmanlike finish.

V. Marking.

14. The name or brand of the manufacturer and the year of manufacture shall be rolled in raised letters and figures on the side of the rolled bars, and a portion of this marking shall appear on each finished splice bar.

VI. Inspection and Rejection.

15. The inspector representing the purchaser shall have free entry, at all times while work on the contract of the purchaser is being performed, to all parts of the manufacturer's works which concern the manufacture of the splice bars ordered. The manufacturer shall afford the inspector, free of cost, all reasonable facilities to satisfy him that the splice bars are being furnished in accordance with these specifications. All tests (except check analyses) and inspection shall be made at the place of manufacture prior to shipment, unless otherwise specified, and shall be so conducted as not to interfere unnecessarily with the operation of the works.

16. (a) Unless otherwise specified, any rejection based on tests made in accordance with Section 5 shall be reported within five working days from the receipt of samples.

(b) Splice bars which show injurious defects subsequent to their acceptance at the manufacturer's works will be rejected, and the manufacturer shall be notified.

17. Samples tested in accordance with Section 5, which represent rejected splice bars, shall be preserved for two weeks from the date of the test report. In case of dissatisfaction with the results of the tests, the manufacturer may make claim for a re-hearing within that time.

HIGH CARBON STEEL SPLICE BARS.

I. Manufacture.

- 1. The steel shall be made by the open-hearth process.
2. The splice bars shall be punched, slotted and, in the case of special designs, shaped at a temperature not less than 750 deg. C.

II. Chemical Properties and Tests.

3. The steel shall conform to the following requirements as to chemical composition:

Table with 2 columns: Element and Requirement. Carbon: not under 0.45 per cent. Phosphorus: not over 0.04 per cent.

4. An analysis to determine the percentages of carbon, manganese, phosphorus and sulphur shall be made by the manufacturer from a test ingot taken during the pouring of each melt, a copy of which shall be given to the purchaser or his representative. This analysis shall conform to the requirements specified in Section 3. Drillings for analysis shall be taken not less than 1/8 in. beneath the surface of the test ingot.

5. Analyses may be made by the purchaser from finished splice bars representing each melt, in which case an excess of 25 per cent. above the requirement as to phosphorus specified in Section 3 shall be allowed.

III. Physical Properties and Tests.

6. The splice bars shall conform to the following minimum requirements as to tensile properties:

Table with 2 columns: Property and Value. Tensile strength, lbs. per sq. in.: 85,000. Elongation in 2 in., per cent.: 14.

7. The bend test specimen specified in Section 8 shall bend cold through 90 deg. around a pin the diameter of which is equal to three times the thickness of the specimen, without cracking on the outside of the bent portion.

8. Tension and bend test specimens shall be taken from the finished bars. Tension test specimens shall be of the form and dimensions shown in Fig. 1. Bend test specimens may be 1/2 in. square in section, or rectangular in section with two parallel faces as rolled.

9. If preferred by the manufacturer and approved by the purchaser, the following bend test may be substituted for that described in Section 7: A piece of the finished bar shall bend cold through 45 deg. around a pin the diameter of which is equal to three times the greatest thickness of the section, without cracking on the outside of the bent portion.

10. (a) One tension and one bend test shall be made from each melt.

(b) If any test specimen shows defective machining or develops flaws, or if a tension test specimen breaks outside the gage length, it may be discarded and another specimen substituted.

IV. Workmanship and Finish.

Same as for medium-carbon steel splice bars.

V. Marking.

Same as for medium-carbon steel splice bars.

VI. Inspection and Rejection.

Same as for medium-carbon steel splice bars.

EXTRA-HIGH-CARBON STEEL SPLICE BARS.

I. Manufacture.

- 1. The steel shall be made by the open-hearth process.
2. The splice bars shall be punched, slotted, sheared and, in the case of special designs, shaped at a temperature not less than 750 deg. C.; except that bars may be cold-sawed.

II. Chemical Properties and Tests.

3. The steel shall conform to the following requirements as to chemical composition.

Table with 2 columns: Element and Requirement. Phosphorus: not over 0.04 per cent.

4. An analysis to determine the percentage of carbon manganese, phosphorus and sulphur shall be made by the manufacturer from a test ingot taken during the pouring of each melt, a copy of which shall be given to the purchaser or his representative. This analysis shall conform to the requirement specified in Section 3. Drillings for analysis shall be taken not less than 1/8 in. beneath the surface of the test ingot.

5. Analyses may be made by the purchaser from finished splice bars representing each melt, in which case an excess of 25 per cent. above the requirement specified in Section 3 shall be allowed.

### III. Physical Properties and Tests.

6. The splice bars shall conform to the following minimum requirements as to tensile properties:

Tensile strength, lbs. per sq. in.....	100,000
Elongation in 2 in., per cent.....	10

7. The bend test specimen specified in Section 8 shall bend cold through 60 deg. around a pin the diameter of which is equal to three times the thickness of the specimen, without cracking on the outside of the bent portion.

8. Tension and bend test specimens shall be taken from the finished bars. Tension test specimens shall be of the form and dimensions shown in Fig. 1. Bend test specimens may be  $\frac{1}{2}$  in. square in section, or rectangular in section with two parallel faces as rolled.

9. If preferred by the manufacturer and approved by the purchaser, the following bend test may be substituted for that described in Section 7: A piece of the finished bar shall bend cold through 30 deg. around a pin the diameter of which is equal to three times the greatest thickness of the section, without cracking on the outside of the bent portion.

10. (a) One tension and one bend test shall be made from each melt.

(b) If any test specimen shows defective machining or develops flaws, or if a tension test specimen breaks outside the gage length, it may be discarded and another specimen substituted.

### IV. Workmanship and Finish.

Same as for medium-carbon steel splice bars.

### V. Marking.

Same as for medium-carbon steel splice bars.

### VI. Inspection and Rejection.

Same as for medium-carbon steel splice bars.

### RAIL-STEEL REINFORCING BARS.

Prof. W. K. Hatt presented a paper giving a description of the method used for rerolling old steel rails into reinforcing bars for concrete work. In a general way the first thing done is to reheat the rails in short lengths and send them through a splitting machine that severs the web from the head and flange, thus dividing it into three sections. These three sections are then rerolled into reinforcing bars of different weights. A table of tests that was presented shows that bars made from the web were the strongest of the three, that this was followed by the bars from the head, while those from the flange were the weakest. This does not mean that any of them were of a low grade as the lowest tensile strength recorded of bars rolled from old rails was 90,000 lbs. per square inch ultimate strength. Of the various types of bars rolled it was found that the twisted bars were weaker than the square and regular forms and that, in addition to this, they did not bend as easily.

It was stated in the discussion that about 100,000 tons of old rails are now rerolled annually into reinforcing bars.

**PROTECTION AGAINST STRIKES IN INDIA.**—The Madras chamber of commerce forwarded to the committee of the Bengal chamber a copy of a representation they had addressed to the government of India on the subject of the strike recently threatened on the Madras & Southern Mahratta Railway. The Madras chamber suggested that the government should consider the desirability of taking such legislative and other measures as might be thought necessary to deal with strikes on Indian railways. The object of these measures would be to safeguard commercial interests, and the convenience of the travelling public, and to ensure that strikes are not initiated without the concurrence of a majority of the railway employees concerned, or without reasonable notice. The Bengal committee agreed to this recommendation, and decided to extend their support to it. It was, they thought, advisable that the question should receive the attention of the government, and that the feasibility of such measures as the Madras chamber had proposed should be considered. They accordingly addressed the government of India in this sense.

## THE RAILROAD VALUATION COMMITTEE.

The railroad committee on valuation of property, appointed to conduct the necessary conferences with the Interstate Commerce Commission, and which was noticed in the *Railway Age Gazette* of May 2 and May 23, met in New York City on Monday of this week and discussed ways and means of assisting the Interstate Commerce Commission in the valuation work which is to be done under the law recently passed. The discussion covered the question of preparation of inventories of the physical property, the extent to which existing records of the railroad companies can be helpful to the government and economical methods of furnishing the same to the commission.

The committee consists of the following eighteen railway officers, all of whom have the title of president except Mr. Trumbull (chairman); Mr. Kruttschnitt (chairman of executive committee); Mr. Winchell (receiver); and Messrs. Storey and Holden (vice-president): Samuel Rea, Pennsylvania; W. C. Brown, New York Central; L. F. Loree, Delaware & Hudson; Frank Trumbull, Chesapeake & Ohio and Missouri, Kansas & Texas; F. D. Underwood, Erie; Julius Kruttschnitt, Southern Pacific; George F. Baer, Central of New Jersey; Daniel Willard, Baltimore & Ohio; B. L. Winchell, St. Louis & San Francisco; W. A. Gardner, Chicago & North Western; B. F. Bush, Missouri Pacific; H. U. Mudge, Chicago, Rock Island & Pacific; W. W. Finley, Southern; T. M. Emerson, Atlantic Coast Line; W. J. Harahan, Seaboard Air Line; L. E. Johnson, Norfolk & Western; W. B. Storey, Jr., Atchison, Topeka & Santa Fe; Hale Holden, Chicago, Burlington & Quincy. The general chairman of the committee is Mr. Rea; Mr. Loree is chairman of the eastern group; Mr. Finley of the southern, and Mr. Holden of the western.

The committee of presidents has added to its number fifteen engineers to deal with details of physical valuation. These engineers will confer with the engineers of the government at Washington, next week, Tuesday. They are Thomas W. Hulme (Penn.), general secretary of the presidents' committee and ex-officio member of the engineers' committee. Four, representing the eastern roads, as follows: Geo. W. Kittredge, New York Central; Charles Hansel, recently valuation engineer for the state of New Jersey; M. L. Beyers, Delaware & Hudson; J. B. McCubbin, Jr., real estate agent, Baltimore & Ohio. Four for the southern district as follows: D. W. Lum, special engineer, Southern Railway; C. S. Churchill, chief engineer, Norfolk & Western; W. L. Seddon, assistant to president, Seaboard Air Line; Robert Scott, superintendent insurance department, Atlantic Coast Line. Five for the western district as follows: E. Holbrook, valuation engineer, Southern Pacific and Union Pacific; H. C. Phillips, valuation engineer, Atchison, Topeka & Santa Fe; C. H. Smith, assistant engineer, Missouri Pacific; J. B. Berry, assistant to president and valuation engineer, Chicago, Rock Island & Pacific; Thomas Cooper, assistant to president and land commissioner, Northern Pacific.

**PROJECTED SUBWAY FOR GENOA, ITALY.**—The Superior Council (Consiglio Superiore) of Public Works of Italy has approved the project for a  $\frac{6}{8}$ -mile subway for Genoa from Sampierdarena to Genoa, and thence to Quarto dei Mille along the coast. Estimates of cost of the work and materials have not been definitely adopted, but the original estimate contemplated expending at least \$3,667,000, which will no doubt be increased. The subway would have 14 stations, four above and ten underground, three of these latter having two or three passenger elevators each. There would be almost 28,900 ft. of underground tunnel, mostly rounded inside, about 3,250 ft. elevated in the open, 1,214 ft. on ground level, and 270 ft. of bridge work. Continuous current, third rail electric traction would be used, the rails to be of the same kind as those on Italian State railways, weighing 93 lbs. per yard.

# THE ST. PAUL IMPROVEMENTS AT MILWAUKEE.

The New Terminal and Hump Yard Which Has Cost \$750,000 and Will Relieve the Congestion Which Had Begun to Be Serious.

The Chicago, Milwaukee & St. Paul has recently completed important terminal developments at Milwaukee, Wis., requiring the moving of nearly a million yards of earth and the expenditure of about \$750,000. It is expected that these improvements will relieve a congestion which has been gradually increasing at this point for several years. In addition to heavy local business at Milwaukee there is a large interchange business with car ferries and boats operating on the lakes. This lake traffic com-

four of which were built as separate lines. The first of these to enter the city was that now known as the Prairie du Chien division coming in directly from the west. A short time later the La Crosse division was built in from the northwest, crossing the Prairie du Chien division at Brookfield, 14 miles west of Milwaukee and entering the city a short distance south of the first line. A short time afterwards the line now known as the Northern division was built from Fond du Lac and Portage to a terminus on the west bank of the Milwaukee river near Chestnut street. Later the Superior division was built from Lake Superior south through Green Bay to a connection with the Northern division north of Milwaukee, using its Chestnut street terminal.

These four lines gradually came under the control of one management, which later built the extension south to Chicago. When the Northern and Superior divisions were taken over, a cut off was built from North Milwaukee to a connection with the Prairie du Chien division at Grand avenue. The trains from these lines were then brought into the terminal used by the La Crosse and Prairie du Chien divisions, the Chestnut street line being devoted to industrial purposes. Later the Prairie du Chien and La Crosse division tracks were operated as double track from Brookfield into the city. A few years ago the Prairie du Chien division was double tracked to Brookfield and all passenger trains and a large part of the freight traffic for both divisions now use this line in both directions.

At the time of their consolidation, each of the four divisions had small yards on their respective lines, but these were gradually abandoned and a general yard for classification purposes

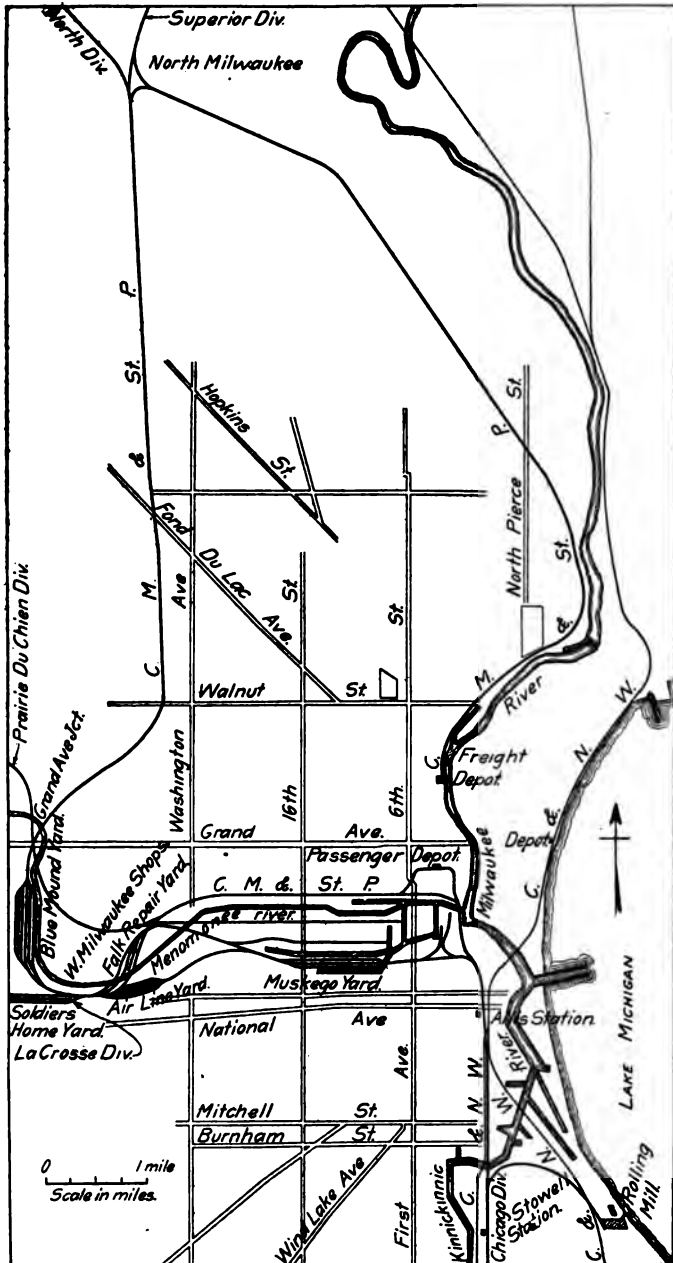

Plan of Milwaukee Terminals of the Chicago, Milwaukee & St. Paul.

plicates the terminal problem seriously because of the storage room required for holding cars several days at a time waiting for boats.

The terminal conditions existing at Milwaukee are best understood by outlining the early development of this road at this point. Entrance to the city is effected by five different divisions,



Profile Over Hump in C. M. & St. P. Air Line Yard.

was gradually built south of the Menomonee river and a short distance west of the present passenger station. This yard has been outgrown for some time and expansion on the present site was limited by the Menomonee river on the north and a line of bluffs on the south. Also, its location was such that the handling of traffic between this yard and the various industries was very expensive. Because of the very high property values, the Chestnut street branch has never been extended south to a connection with the other lines near the present station, although only about five blocks intervene. A large amount of freight is destined to and originates on this branch. All this traffic has to be taken from the classification yard west and north through Grand Avenue Junction and North Milwaukee, making a haul of about 15 miles. Much of this traffic comes from the northern and western divisions and passes Grand Avenue Junction and North Milwaukee on the way into the city, so that a considerable back haul results. Likewise, a large amount of business destined to the rolling mills about five miles south of the yard came from Chicago, frequently in trainload lots and a similar back haul resulted here. Such was the condition when the present systematic development of the terminal facilities was authorized.

## BLUE MOUND RECEIVING YARD.

The first step taken was the building of a new eastbound receiving yard near Grand Avenue Junction in order to eliminate the back haul on the freight destined for the north and west sides of the city. Property was secured along the west bank



of the Menomonee river from Grand avenue south to the old La Crosse division on which this yard is being built. The river was moved eastward for about 2,000 ft. and straightened to provide room for the tracks. With the exception of a small hill at the south end of the yard, which was cut down and the material placed in the embankment, the entire yard is built on a fill averaging 20 ft. in height and requiring about 550,000 yards of earthwork. This material was loaded by steam shovels in gravel pits about 20 miles west of the city and brought in by trains. From Grand Avenue Junction four main tracks, two each for freight and passengers, extend south about 1,000 ft. to the north end of the new yard. The passenger tracks turn east at this point, while the yard continues south almost to the old La Crosse division tracks, where it turns through an angle of approximately 90 deg. and terminates in a lead to the hump yard a short distance east. Six 80 car tracks extend the entire length of the yard. Eleven other tracks with a capacity of 50 cars each are provided, while four short tracks are built south of the main yards, where way freights can be handled without delay or interference to other traffic.

The ladders to each end of this yard are on curves, the inside track at the south end being on a 7 deg. 30 min. curve with the ladder leading off from this on a somewhat flatter curve. To maintain a uniform distance between tracks and a uniform curvature through the leads, as well as to provide a smooth curve along the ladder involved some complicated work. No. 12 turn-outs were used at the south end and No. 10 on the north end, where the curvature was less. Tracks were laid on 13 ft. centers with 14 ft. next to the main lines and 20 ft. along ladders. The tracks slope towards the river 0.15 ft. per track to facilitate drainage. Ladders and running tracks are laid with 85 lb. rail and 65 and 75 lb. rail were used in the yard. A small mechanical interlocking plant in operation at the Grand Avenue Junction will be enlarged while an additional mechanical plant will be built at the north end of the receiving yard.

AIR LINE CLASSIFICATION YARD.

The east end of the receiving yard leads directly to the hump and classification yard. The hump and 21 tracks were built three years ago, 13 of these tracks being connected with the hump while the remaining 8, with a capacity of 548 cars, were connected with the main line to be used for refrigerator, stock and other trains which do not need to go over the hump. Eleven additional tracks connected with the hump were built last year. That portion of the yard built three years ago was placed largely on refuse material which settled so much that the entire yard had to be raised and resurfaced, while the hump also had to be raised a couple of feet. This required about 140,000 cu. yds. of grading. This yard is now completed and in service, and is operated with 24 tracks with a capacity of 1,162 cars served by the hump.

Bad order cars are run from the hump onto a separate track on the north side of the yard from which they can be pulled directly into the new repair yard. This latter yard has recently been completed and consists of 18 tracks built in pairs, the tracks being alternately 13 ft. and 20 ft. center to center. A standard gage supply track is provided between each pair of tracks. One track has been depressed to facilitate the unloading of wheels and other heavy material. This depressed track is working very successfully, two men now being able to unload material which previously required 17 men.

The Blue Mound receiving yard connects through the south ladder to the hump in the Air Line yard on a level grade which changes at the foot of the hump to a 2 per cent. ascending grade

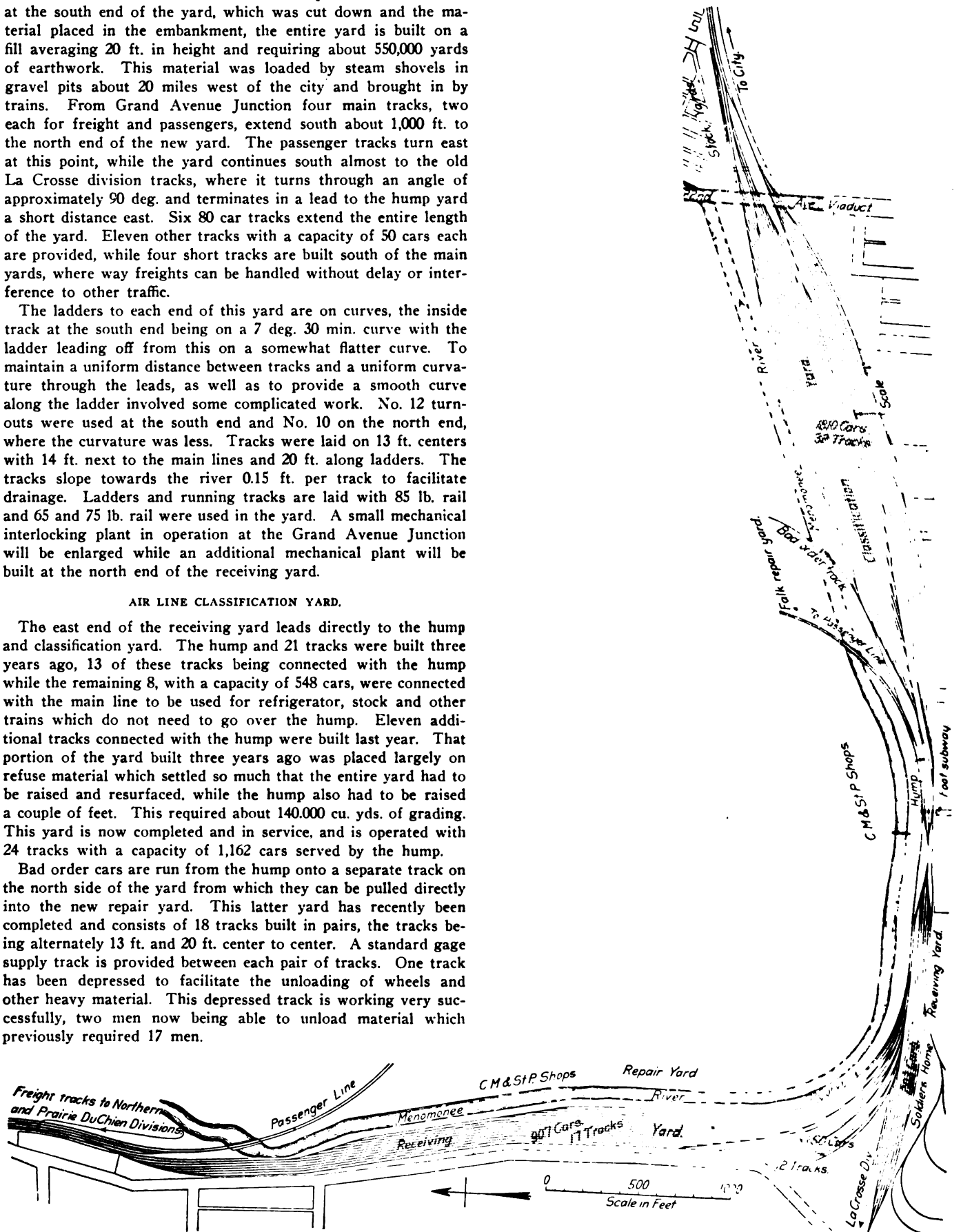

Track Layout in New Gravity Yard at Milwaukee.

for 375 ft. Passing over the summit on a short vertical curve 40 ft. in length, there is then 300 ft. of 3.25 per cent. grade descending onto the ladders. From this point the southerly track off the hump continues for 1,800 ft. on a .3 per cent. descending grade, where it changes into a .09 per cent. grade to the end of the yard. To provide for transverse drainage towards the river on the north, the grade from the foot of the hump is continued through the ladder onto the north track at 1.10 per cent. for 800 ft. after which it is reduced to 0.1 per cent. for the balance of the distance through the yard. The grades of the intervening tracks are adjusted between these two limits to provide for uniform transverse slopes.

SMALL STORAGE YARDS.

One interesting feature connected with this development is the construction of small storage yards on each of the lines entering the city, outside of the present yards but within the switching limits. In this way, should the receiving yard be blocked it will not be necessary to hold a train out on the line or to block a passing track, but the train will be left in this yard only a few miles out and the engine and crews released. The train can then be brought into the receiving yard by a switching engine whenever there is room for it. Two such yards of two 72 car tracks each are located on the Superior and Northern divisions a short distance north of North Milwaukee. A third yard of four 80 car tracks for the two western divisions is built at Elm Grove, nine miles from the city, while a fourth yard with five 40 car tracks is located on the old La Crosse division adjacent to the south end of the receiving yard. This yard will be used for the collection of traffic from various industries along this line and also for trains from the two western divisions, which can be diverted over the old La Crosse division from Brookfield.

At Lake, seven miles south on the Chicago division, two yards of six 75 car tracks each are being built. A third track is also being built from the city to this yard, the combined work requiring 115,000 yards of grading. This yard was located at this point because Lake lies at the summit of the ruling southbound grade between Milwaukee and Chicago, and in this way practically governs the spacing of the trains for the entire 80 miles. Tonnage freight trains now require help up to this point and at best move very slowly. The construction of the third track will not only provide for switching movements between this yard and the city, but will also assist in the movement of the slow freight trains. All traffic for the rolling mills and other industries on the south side of the city will be set out and picked up in this yard. In this way many trains can come over the ruling grade with reduced tonnage and fill out at this point, while the back haul on cars destined to the rolling mills and other industries will be eliminated.

This work was handled under the direction of C. F. Loweth, chief engineer; W. H. Penfield, formerly assistant chief engineer and now assistant to the vice-president, and Charles Lapham, district engineer with W. B. Swartwout, assistant engineer in charge of the construction.

OPENING OF MADAGASCAR RAILWAY.—Through service was inaugurated on March 9 over Madagascar's railroad between Tananarive, the capital, and Tamatave, the principal port. It is 229 miles long and cost \$13,210,850. There is now a biweekly passenger and mail service of 15 hours and a through daily freight service of 36 hours, as well as a local freight service. The first-class passenger fare is 6.2 cents per mile; second-class, 3.1 cents; and third-class, 1.24 cents; with 25 per cent. reduction on 30-day round-trip tickets. Season tickets are also issued. Freight is classified into five categories, and pays going up country, toward Tananarive, 1.5 to 18 cents per ton per mile for the first 150 kilometers (93.21 miles); 1.5 to 15.5 cents, from 150 to 200 kilometers (93.21 miles to 125 miles); and 1.5 to 11 cents beyond 200 kilometers. Coming down from Tananarive the rates on freight are 1.5 to 14 cents per ton per mile for all distances.

ASSIGNMENT OF EQUIPMENT VALUATION BY STATES.\*

By A. I. THOMPSON,

Engineer, Corporation Commission of Oklahoma.

In the apportionment of the cost of steam railroads, one of the most important items is the equipment assignment to the several states. Actual railroad practice shows that some equipment is permanently assigned for a fiscal period, while other equipment is used promiscuously over the system and where traffic demands its use.

In order to arrive at a reasonable assignment of the cost of rolling stock, it is, therefore, necessary to adopt some plan by which each state will be charged with the cost of equipment which is actually used therein. There are several theories, but only one correct method.

The assignment of cost of equipment to the several states on the "road mile" theory contemplates that that portion of the total cost of all equipment be assigned to the states which is represented by the fraction of the "road mileage" within the given state over the total "road mileage" of the company. For example, if the road mileage of a carrier in a given state was 100 and the total road mileage of a system 1,000, then one-tenth of the total cost of equipment, regardless of kind, class, type, cost or where operated, would be assigned to that state, as illustrated by the following table:

M. K. & T. RY. ASSIGNMENT OF EQUIPMENT, IN SERVICE, TO OKLAHOMA ON THE "ROAD MILEAGE" THEORY, AS OF JULY 1, 1912.

Main track mileage of system.....	1,744.44
Main track mileage in Oklahoma.....	729.52
Steam locomotives, average cost per mile.....	\$4,417.69
Passenger train cars, average cost per mile.....	1,886.00
Freight train cars, average cost per mile.....	10,204.22
Work equipment, average cost per mile.....	706.00
Average cost per mile, all classes.....	\$17,213.91
Average cost per mile, all classes, less depreciation.....	\$12,450.29

The fallacies of this theory are that the cost of equipment is not assigned in accordance with the traffic demands or "use" of such equipment, and a state with a greater proportion of branch line mileage would be charged with cost of equipment which had never been used in that state.

Apply this theory, in assigning the cost of the Atchison, Topeka & Santa Fe equipment, to Oklahoma, with 843 miles of operated road, and Illinois, with 290 miles of operated road, practically all main lines. In Illinois trains are operated as frequently as time permits, and with higher and more expensive equipment than in Oklahoma, and one can readily see that this theory of assigning equipment would not be equitable and, therefore, would be radically wrong. In rate litigations the carrier would have cost of equipment assigned and included in a given state which had never been operated in that state.

At a recent conference in our state, the committee for the carriers brought forth a theory of assigning equipment which

Equipment, in service, assigned to Oklahoma on a mileage basis in the proportion as the miles made on each class of equipment in the State bears to the miles made on the entire system by the same class of equipment, except work equipment, which is in the proportion of the total miles made on the entire system:

Classes.	M. K. & T. Ry. Co.		Av. cost per mile assigned to Oklahoma.
	Mileage made on system.	Mileage made in Oklahoma.	
Steam locomotives .....	9,740,669	3,877,203	\$4,194.69
Passenger train cars .....	15,334,810	6,875,966	2,017.12
Freight train cars .....	110,037,327	43,843,678	9,698.87
Work equipment .....	222,722,806	54,596,847	412.83
Average cost per mile, all classes.....			\$16,323.51
Average cost per mile, all classes, less depreciation.....			\$11,838.27

may be defined as the "total car and locomotive mile" theory, which contemplates that such portion of the total cost of all equipment be assigned to a given state as is represented by the

\*Abstract of a paper presented at a conference of Railroad Commissions of Mississippi Valley States, Des Moines, Iowa, on June 6, 1913.

fraction of the total passenger, freight, work or locomotive miles made in a state over the same factors for the system. Thus if the total locomotive miles in the state were 100 and on the system 1,000, then one-tenth of the locomotive cost of the respondent would be assigned to such state, as illustrated by the accompanying table.

The mistake is automatically made where this theory is used, that differences in traffic conditions which require either heavy or light locomotives, old or new passenger cars, are not accurately reflected. We do not believe the assignment of cost of expensive locomotives or passenger equipment to the state where such locomotives or passenger cars were never operated would be fair or just. For instance, the state of South Dakota, in which we understand there is not an expensive locomotive on the Chicago & North Western, or an electric lighted or steam heated passenger car, should not be charged with the cost of such equipment.

If the plan of assigning equipment cost is unfair or unjust to one state, then the assignment of costs to all states on that system is relatively unfair. If the state of South Dakota or Oklahoma, or any other state, is charged with any other than the cost of the actual equipment used in that state, then the value of the assignment to all other states is also in error. So, if, by use of the foregoing theories, a state is charged with more than its pro rata of the cost, then, to be fair, we must produce a formula which will permit of the assignment to all states of such equipment as is actually used therein.

With the individual assignment of equipment on the "use" basis, the writer believes that the carriers should receive the benefits of the actual cost of equipment actually used for public service. If given states are benefited by the operation of heavy power, or new, expensive and luxurious equipment, then the traffic of such given states should bear the burden. The writer further contends that heavy, new or expensive equipment will not be installed by the carriers, except where the traffic demands it, and that the unit cost will not, in his opinion, be greater than where the traffic and equipment are lighter.

Rates in the state of South Dakota, or any other state, should be based in part upon the cost of equipment actually operated there. If traffic in a state does not receive the benefit of electric lighted and steam heated cars, and up-to-date motive power, it would be manifestly unfair to charge such traffic with the cost of such equipment. If the total freight car valuation should be assigned upon a total mileage basis, i. e., according to the relation of the freight car miles in the state to the total freight car mileage of the system, then I would approve of the charging of increased cost of equipment to a state or division, when actually only a part, and in some instances not any of a particular kind or class of equipment had been used.

In order, therefore, to secure an impartial cost it is necessary to assign equipment upon an actual "use" basis. We will discuss each phase separately.

#### LOCOMOTIVES.

The cost of locomotive equipment should be assigned to a given state, and division, in the ratio that the miles made by that individual locomotive in that state or on that division, bears to the total mileage of that locomotive as made during the fiscal year for which the report is rendered.

The statement has heretofore been made that heavier and more expensive equipment is used in Illinois than is used in Oklahoma. During the fiscal year ended June 30, 1911, the average number of tons of freight per train mile in Illinois on the Santa Fe was 357.99, and in Oklahoma, 280.32; the average number of cars per freight train mile in Illinois was 33.78, as compared with 26.80 in Oklahoma. On the Rock Island the average number of tons of freight per train mile in Illinois was 437.62 compared with 246.18 in Oklahoma; and, the number of freight cars per train mile in Illinois was 34.39 compared with 26.30 in Oklahoma.

In view of these facts, it is reasonable to assume that in states like Illinois, where traffic is heavy and equipment used is more

luxurious and expensive than in South Dakota, locomotives are larger and more expensive. If this fact is ignored, the public through the regulating commissions, would certainly have reason to object, and the right to exercise control over supervision would become more essential. If the carriers, in states where traffic is light, should persist in operating power too expensive and heavy for traffic, the public through the regulating commissions would certainly have reason to object, and the right to exercise supervision over such carriers would become more essential. On the other hand, if traffic is heavy and carriers persist in attempting to operate with light power, the necessity for public regulation is again emphasized.

I have the greatest consideration for the ability of the operating official, who, knowing that the traffic demands light or heavy power, can use locomotives adequate for the service without detriment to it, and the assignment of the cost of equipment should reflect the true cost. I believe those conversant with railroad practice will agree that the large locomotives are located where there are excessive grades or where heavier trains are handled. There is no consistency in charging to South Dakota, for example, a part of the cost of the expensive locomotives used in pulling the immense trains between Chicago and Cedar Rapids, while the locomotives actually used in South Dakota (perhaps adequate for the service demanded of them) are in such a condition that, from a tonnage standpoint, their operation on the main line would increase operating expenses. It must be admitted, of course, that the heavy through passenger trains, such as the "Pioneer Limited" and the Santa Fe "De Luxe," consisting of heavy Pullman cars, require a heavier class of power than trains in South Dakota, with only a few coaches. Superheater compound locomotives cost more than simple engines, and if any other than an assignment on the "individual locomotive" basis is used, cost will be assigned which has no connection with the actual "use" or operation. With but little additional expense records of the operation of these locomotives can be kept. A great many carriers keep records of the performance of individual locomotives at this time.

#### PASSENGER CAR EQUIPMENT.

Passenger train equipment generally is permanently located for each fiscal year, and thus we find that on many lines the same cars are used from year to year. The cost of passenger car equipment should be assigned to the several states in the proportion that the individual car mileage in a given state bears to the total mileage of the individual car during the year. Citing again the example of the South Dakota car, the writer feels certain that that state should not bear the cost of expensive steel equipment, cafe and dining cars and the like, when it is shown that such equipment is not operated in that state. The passenger traffic in South Dakota should not be charged with the cost of reclining chair cars unless traffic receives the benefits of chair car operation.

#### FREIGHT CAR EQUIPMENT.

Although at this time it may be impracticable, the proper method of charging the cost of freight car equipment would be assignment to the states on the individual car mileage basis. A method which is more practical and one which should be used, is to assign to each state, and division, that portion of the cost of box car equipment that is represented by the fraction of the "box car mileage" made in the state or division during the period for which the report is made and the total box car mileage on the system. The use of the foreign car miles for the assignment of equipment is on account of the operating practice of using, without discrimination, foreign cars in lieu of system owned cars. Thus, if the foreign and system box car miles in a given state were 100 and the total foreign and system box car miles on the railroad's line during the fiscal year were 1,000, then one-tenth of the total box car cost should be assigned to the given state. If the same method is applied to cabooses, refrigerator, coal and stock cars, etc., individually, it will permit of an assignment of classes of equipment to the territory where

those particular classes of equipment predominate. On a division or in a state where coal traffic predominates, more coal car equipment should be assigned than in a state or on a division where the traffic demands furniture cars. By assigning freight car equipment cost by individual classes, a very accurate assignment can be made, and traffic involving the use of any particular class of cars will have to bear its proportion of the cost.

When units of equipment are not in service during a fiscal year, the cost thereof should be apportioned to the several states in proportion to the respective states' car or locomotive mileage.

#### WORK EQUIPMENT.

Work equipment cost should be assigned to the several states on the "use" basis—i. e., the cost of each unit should be assigned to a given state in the proportion that the time it has been in service in that state bears to the total time it was in service during the period for which the report is rendered. It is understood that the dead time of each unit shall be apportioned on the basis of the car and locomotive mileage of those states only which would be benefited by it if in use. For example, if a railway owned a steam shovel that cost \$2,000, and for the year in question it was in service six months in Oklahoma and six months in Kansas, then the cost should be apportioned equally to each state.

When units of work equipment are not in service, their cost should be apportioned on the basis of the respective states' car and locomotive mileage during the year for which the report is rendered, but again such apportionment should be made only to those states which would, in ordinary practice, receive the benefit of them. This would prevent the assignment of the cost of rotary and other snow plows to southern states, and other apparent inconsistencies.

In conclusion, in my opinion, unless the assignment is made on the "unit basis" the efficiency of the various commissions' studies of the operation and depreciation of car and locomotive equipment will be destroyed, and the value of the compiling of statistics will be greatly impaired.

#### NEED OF BETTER BOXES FOR FREIGHT.\*

From statistical reports of the Interstate Commerce Commission it is estimated that an annual loss to our national resources of not less than thirty millions of dollars is sustained through damage to railway freight. The magnitude of this loss and the fact that millions of our fellow citizens are vitally interested in minimizing it, insures the attention of this Society for any reasonable comment. Among the prominent causes we recognize theft, insecure packing, illegible and incorrect marking, rough handling of packages in cars and improper loading of freight into cars. We are to give special attention to the advisability of standardizing specifications for shipping containers with a view to minimizing the losses that are due to insecure packing.

During the rush period in the late afternoon receiving clerks are barely able to verify the shipper's list of packages and no time is available for a critical examination of these packages to discover defective containers. Add to this the natural contention of railway traffic officers that revenue-bearing freight should not be refused under any circumstances, and it is plain that the carrier is not well protected against the shipper who is willing to reduce the cost of his shipping container at the expense of its efficiency. The carrier's struggles against freight congestion have developed the automatic coupler, the gravity track or "hump" and the steel-underframe freight car. The effect is to reduce from minutes to seconds the time required to move and group these cars on specified tracks and to increase correspondingly the severity of the shocks incident to this rapid disposition. The steel-underframes will stand the shocks and the trainmen do not see, as a rule, the effect on the packages in the car. It is useless

to suggest as a remedy that we avoid all shocks to cars. Some increase in the roughness of handling cars is a natural development in the struggle against congestion of freight.

What is a reasonable limit to the speed in miles per hour at which a freight car should be permitted to collide with other cars in switching movements? The answer must recognize the conditions that require the classification of a large number of cars in a limited time. To couple cars carefully, the speed should not exceed two miles per hour at the instant of collision. This limit was not observed with any degree of uniformity even when hand-operated couplers were in use. Friction draft gears, now used almost to the exclusion of the old spring buffers, are constructed to absorb about 18,000 ft. lb. of energy each, or 36,000 ft. lb. for the two gears involved in any impact. This energy is furnished by a loaded freight car weighing 150,000 lbs. and moving at a speed of 2.68 miles per hour. For any speed in excess of this the additional energy must be absorbed by the elastic, or permanent, deformation of the car frame. The draft-gear energy limit of 36,000 ft. lb. restricts the coupling speed for an empty freight car of average weight to about five miles per hour. When a column of packages occupies the entire length of a car the pressure on the end package for a coupling speed of five miles per hour may exceed five times the total weight of the column of packages. When these packages are free to slide along the car floor the coefficient of friction will be high and a path of from two to three feet may suffice; but this frictional resistance is not a practical remedy.

Some of the men employed by the railways to handle freight cars are criminally careless and indifferent. They work frequently at night and at isolated points where direct and constant supervision of them is practically impossible; and they belong to labor unions that are credited with resisting unreasonably, but successfully, the disciplining of their members. The development and use of a reliable and efficient time and shock-recording instrument would help to prove their delinquencies in handling cars roughly. An extended educational campaign, persistently followed, should secure the cooperation of the better and more numerous class of trainmen and the exercise of their influence over their careless and indifferent members.

It is not wise to strain any material beyond its elastic limit, and the path required to absorb the energy of a colliding freight car ought not to exceed that afforded by the friction draft gear. There is a distinct advantage in permitting the coupling speed for the average car to be as high as the draft gear will permit, as this will facilitate prompt movement of cars and delivery of freight. Let us assume by way of illustration that the maximum limit for this speed is placed at four miles per hour and that the maximum pressure on a package of freight in the end of the car due to this shock is four times the total weight of the column of packages in the length of the car; then the shipper should furnish a package capable of standing this pressure with a reasonable factor of safety.

For goods requiring protection, shipping containers made under standard specifications should be used. Instead of standard specifications we now have unlimited competition in the reduction of cost. The average box maker knows approximately the thickness of lumber that he should use in a given box, but he will cease to be an average manufacturer if he refuses to reduce this thickness to any degree necessary to secure or keep a customer. The average shipper may know that a fiberboard box does not possess the required strength to protect his material against pressure, but he is liable to take the chance as long as he can collect his freight claims. The shipper who realizes and meets his obligation to use efficient containers feels constrained to follow the example of a less scrupulous rival in reducing the cost of his shipping department.

When the fiberboard box was introduced some years ago as a proposed substitute for the wooden box as a shipping container, the railroads noted its failure in many cases to protect its contents and additional freight charges were assessed as "penalties" against the substitute package. The wooden-box mak-

\*Extracts from a paper on Conservation and Shipping Containers, by Col. B. W. Dunn, Chief Inspector of the Bureau of Explosives, read before the American Society for Testing Materials, at Atlantic City, June 24.

ers did not appreciate the importance of their new competitor and really encouraged its growth by their failure to follow its standardizing example. Many of them fear at the present time that a standard for wooden boxes would, by increasing the average cost, give an increased leverage to the promoters of the substitute package. This fear is not well founded. If a standard for a stronger package is established it will be used to keep the weaker one from adoption for the shipment of freight that needs protection against pressure.

Even if we could overcome all other impediments to the preparation of standard specifications for all kinds of containers, boxes, barrels, etc., there would still remain the pronounced difficulty of doing so. The thickness of lumber in a box, for example, would have to depend on the kind of lumber, the size of the box, and the weight of the contents. A standard only approximately correct would be better, however, than none; and a serious attempt by one or more experts in each package-manufacturing industry would soon furnish at least an approximately correct standard for the product of that industry. . . .

The Bureau of Explosives has prepared specifications for metal and wooden packages for explosives and other dangerous articles (samples of which were presented by Colonel Dunn) and the Interstate Commission has approved them. The Commission might well exercise the same authority over shipping containers for all kinds of freight. . . .

### NEWARK BAY TRESTLES REBUILT IN TWELVE DAYS.

The destruction by fire of about two-thirds of a mile of the trestle bridges crossing Newark Bay at Oak Island, N. J., was noted in the *Railway Age Gazette*, June 20, page 1580. The two companies interested, the Pennsylvania and the Lehigh Valley, got men and materials on the ground within a few hours after the fire was put out, and at noon, June 27, traffic was resumed over the bridge, two tracks having been completed in 12 days. The amount of lumber used was 2,857,059 ft., and about 1,500 men were constantly employed, an average of 1,000 men in the day time and 500 at night.

The Pennsylvania bridge, double track, was south of that of the Lehigh Valley, which also was double track. To restore communication as quickly as possible the Pennsylvania rebuilt its north track and the Lehigh Valley its south track; and they now have one double track railroad over the section that was burnt, which they use jointly. Nine contracting firms, engaged immediately after the fire, took part in rebuilding the bridges. Those engaged by the Pennsylvania worked from the east end and those engaged by the Lehigh Valley worked from the west end, finishing both tracks as they proceeded. The superintendent of the Pennsylvania was on the ground night and day, together with the principal assistant engineer, two division engineers, two supervisors, one assistant supervisor and three corps of engineers. On the part of the Lehigh Valley there was the superintendent and a somewhat smaller staff of officers. The underframes of many of the freight cars which were burnt having been of steel and very difficult to handle.

The tracks on these bridges are about 26 ft. above high water. The fire destroyed the superstructure and the piles down to the water's edge. The work of reconstruction began with sawing off the piles at the water level. On these were laid transverse sills, 12 in. x 14 in., and on these a new trestle was built, the legs being of 12 in. x 12 in. timbers. The batter posts are about 20 ft. long.

The disposition of the heavy traffic over these bridges during the 12 days that they were impassable was a problem of magnitude. The average daily traffic over the Lehigh Valley is about 40 trains each way and that over the Pennsylvania (to the Greenville freight terminus) about 35 trains (800 cars a day each way). Freight from western points on the Pennsylvania

was sent north from Trenton, N. J., over the Belvidere Delaware division and the Lehigh & Hudson River to the Poughkeepsie bridge. About 5,000 cars, eastward and westward, were moved over this route. Considerable freight was moved to and through New York City by taking it over the Pennsylvania passenger line to the junction with the Delaware, Lackawanna & Western, east of Newark, whence it found an easy route to the facilities of the Lackawanna tidewater terminals. Other freight, in large volume, was taken to Waldo avenue, Jersey City, and thence southward over the tracks of the National Docks Railway, and, by means of a short connection which was built, to the tracks of the Lehigh Valley, and thence to the Greenville yards. The Hudson River docks of the Erie were also availed of to deliver cars to floats for transfer to Long Island City and other points in the harbor.

The Lehigh Valley suffered less inconvenience than the Pennsylvania, a connection with the Central of New Jersey, west of Newark Bay, having afforded convenient access to the main line of the Central, and thence to the Communipaw terminal of the Lehigh Valley, which is adjacent to the Central of New Jersey yards.

The following gives some of the interesting details of the work:

About 70 men were fed at the camp, including engineers, clerks, linemen, etc., the other men providing their own meals. Supervising force of engineers, etc., slept at the camp. There were two shifts of workmen, one day and one night, each working 12 to 16 hours. Floating derricks were employed to remove the wrecks of steel cars, etc.

In cutting the steel rail in order that it might be removed, from 100 to 120 men were employed, together with several oxy-acetylene cutting tools.

The following contractors were employed during the reconstruction: Stillman-Delehanty-Ferris Company, R. P. & J. H. Statts, Henry Steers, Stern Construction Company, General Engineering & Construction Company, Rodgers Construction Company, P. Sanford Ross, Interstate L. & T. Company.

There was a physician on duty constantly during the progress of the work. For the supervising force there was provided an office car (coach) dining car, Pullman car and coach, with seats taken out and fitted with cots, the latter for the kitchen help. All these cars were completely screened and the dining car and sleeping car sewered and drained into a cesspool. Fortunately there was but little need for the services of the physician, a few men meeting with minor injuries and one man having his arm broken.

A complete electric light plant was established at the western end of the burned structure and wires carried out over the burned portion. On the eastern end, connection was made with the railroad company's electric light plant at Greenville yard and with the Public Service company's lines, and both arc and incandescent lamps carried out from the eastern end so that the whole of the burned portion of the bridge was provided with electric lights for night work.

Telephone lines were run out to about the middle of the burned portion, placing telephones to facilitate communication between the various parts of the work.

**HARBOR AND RAILWAY IMPROVEMENTS AT FUSAN, KOREA.**—The new railway pier at Fusan is one of the best works of its kind in the Far East. It is a little more than 906 ft. long and not quite 77 ft. wide, comprising nearly one and two-thirds acres. It is built mainly of steel and runs along an embankment reclaimed from the sea. The iron material used weighs 1,365 tons and was partly manufactured in Japan. The front of the pier was dredged to the depth of 24 ft. at low tide and two steamers of 3,000 tons each can be moored with ease at the same time. The embankment is about 420 yds. long and 38 yds. wide and is protected by a breakwater on the northern side. Rails connecting the pier with the Fusan station are laid.

## SMOKE PREVENTION AND THE MECHANICAL STOKER.

D. F. Crawford, general superintendent of motive power of the Pennsylvania Lines West of Pittsburgh, spoke on "The Elimination of Smoke," before the New Century Club of Philadelphia, Pa., on May 15, 1913. He said in part:

"While it is true that locomotives produce a certain proportion of the smoke in localities where they are used, it is a fact that if all of the locomotives in use were to cease making smoke, but 20 to 40 per cent. of the smoke in cities such as Philadelphia, Chicago, Cleveland and Pittsburgh would be eliminated, leaving from 60 to 80 per cent. of the smoke now existing to trouble us. The railways of America produce transportation of passengers and freight at the lowest cost of any in the world, and to obtain this result large locomotives, and consequently large coal consumption, is necessary, and large coal consumption with comparatively small boilers means smoke. The dimensions of the locomotive boiler must be confined to the permissible limits of width and height clearance; its length made to conform to the limit of practicability, and for these reasons it is impossible to increase the capacity of the boiler; the further reason that the public demands rapid and luxurious transportation makes it impracticable to reduce the work required of each unit.

"The railways are most vitally interested in the elimination of smoke for economic reasons, namely, while smokeless combustion does not always mean economy, combustion with heavy smoke always indicates loss, and as many millions of dollars are spent annually for coal, even a small saving per locomotive would make a large sum in the aggregate. The property of the railway adjacent to the track, such as stations, bridges, signals, telegraph lines, etc., is damaged and deteriorated by smoke, requiring large expenditures for renewals, as well as for maintenance, such as painting and cleaning. The possibility of largely reducing the expenses for the items above mentioned, without reference to the viewpoint of esthetic or personal comfort, has been a sufficient incentive to cause the railway people to give the smoke subject a large amount of consideration. This personal interest, the interest of the community (which, I assure you, is regarded to a much greater extent than is generally supposed), added to the possibility of the savings mentioned above, has led to almost continuous study of the locomotive smoke problem. This study has extended over 25 years to my personal knowledge, and from the records, many years farther back.

"During the last 15 years I have examined drawings and patents of many devices which were supposed to eliminate smoke, and have made personal observations of their performance. Unfortunately but very few of these were even promising, and if worthy of installation and trial, the results obtained were not such as to warrant using the apparatus in regular service. The Pennsylvania Railroad system has devoted a great deal of attention, and expended a large amount of money in experimenting with and developing, either on its own account, or in co-operation with representatives of other railways, or the technical societies, devices which gave promise of reducing the smoke from locomotives, and in 1910 the management sent a committee of three to Europe to study conditions and results obtained with the various devices and methods in use there, for comparison with the practice in this country. For many years devices designed to admit steam or air into the locomotive firebox have been used as a means for reducing smoke, with generally unsatisfactory results.

"During the past year, however, a device for supplying air to the firebox was developed and subjected to rigid and painstaking scientific study. Tests were made at the locomotive testing plant of the Pennsylvania Railroad, and the results were confirmed by carefully watching the performance of the locomotives in regular service. This device considerably reduces the amount of smoke under some conditions, and the results obtained so

far are sufficiently promising to permit extending its use, especially for the smaller locomotives.

"During the past nine years there has been developed on the Pennsylvania Lines West of Pittsburgh a device which, up to the present time, is the most promising yet produced for the reduction of smoke, and in fact under favorable conditions, the practical elimination of locomotive smoke. I refer to the locomotive stoker, with which 154 locomotives have been equipped and 140 more are under construction. With this stoker we have succeeded in greatly reducing the amount of smoke emitted by locomotives in heavy passenger train, freight and switching service. Repeated comparisons of the smoke made by locomotives with and without the stoker show that those equipped with the stoker may be operated with from one-tenth to one-fourth of the smoke made by similar locomotives in the same service without the stoker.

"As stated above, this is the result of nine years' experimentation and development, but now while the apparatus is sufficiently developed to warrant the trial of a large number, the problem of maintaining, and satisfactorily operating them, with various kinds of coal, is still before us.

"What does this mean to you as to reducing the annoyance from locomotive smoke? Only this—that there are now in existence two devices for reducing the smoke from locomotives which are sufficiently promising to make it probable that the use of them will be extended, and that the information obtained from them is likely to lead to the development of others.

"In addition to the study and development of mechanical devices for the elimination of smoke, the railways, by additional supervisors and instructors, are causing reduction in the amount of smoke emitted, by having more careful firing and handling of locomotives by the enginemen, and are making a comprehensive study of the problem of reducing the amount of smoke about engine houses, where fresh fires are made, the smoke from which is the most difficult to control.

"All of this shows that the railways are keenly interested in this subject, and in addition thereto the American Railway Master Mechanics' Association has a committee studying the problem, and the railways are also co-operating with the various other associations and city officials interested."

**PROPOSED LINE FROM ARGENTINA TO BRAZIL.**—D. Fernandez has again petitioned Congress for a concession to build and work a railway from Reconquista in the Province of Santa Fe to Uruguayana in Brazil.

**DOUBLE TRACKING ON SOUTH-EASTERN RAILWAY, RUSSIA.**—The South-Eastern Railway has started laying a second track for 70 miles between Griasy and Lisky, on the Kozloff-Rostov branch. The company has been authorized to purchase 1,000 covered freight cars to raise the freight rolling stock to the number required by the Minister of Ways of Communication. To meet these expenses the company has assigned \$1,905,500, advanced from the cash fund of the company, which must be later covered by a loan.

**CANTON-HANKOW RAILWAY, CHINA.**—The section of the Canton-Hankow railway from Canton to Yingtak was ceremonially opened on May 25. The event marks the completion of the first 100 miles from the southern end of the line. The total length of the line is approximately 730 miles. The Kwangtung section, about 209 miles in length, is being built by the Kwangtung Mercantile Administration of the Yuet-Han Railway, a Chinese company. The first 65 miles of the route from Canton were opened to traffic at the end of 1911. Since then there have been many hitches. At Yingtak, the scene of the opening festivities, a bridge consisting of six spans has been constructed. There is another bridge of 750 ft. in length at the one hundred and fiftieth mile, now under construction, and a tunnel about 1,000 ft. in length at mile 160.

## General News.

The trains of the Wheeling & Lake Erie no longer run to the Union station in Toledo, the passenger business now being done at the Cherry street station. These trains have used the Union station for the past ten years.

It is announced at Washington, that the Bureau of Standards of the Department of Commerce, is to make a study of failures of car wheels and axles, taking as a text the records of train accidents kept by the Interstate Commerce Commission.

In the wreck of a west bound passenger train on the Canadian Pacific near Ottawa, Ont., on the 8th of June, eight passengers were killed and a large number injured, some of them fatally. The train was running at moderate speed on an embankment adjacent to the Ottawa River and two of the eight cars of the train fell into the water, and some of the victims were killed by drowning. The passengers were emigrants from the British Isles, bound for Western Canada.

The Chicago Great Western, through Asa G. Briggs, has announced that since the Supreme Court, in the Minnesota rate cases, had held the rates confiscatory with regard to the Minneapolis & St. Louis, that it was the opinion of the Chicago Great Western that the same would be held to be the case with that company and that, therefore, the company would not pay refunds on excess charges during the period of rate litigation. The amount involved is understood to be about \$300,000.

The motormen and conductors employed by the Philadelphia Rapid Transit Company, Philadelphia, have had their pay increased. The new scale provides a maximum rate of 29 cents an hour for men who have been in the employ of the company for five years and over, while new men receive 23 cents with 1 cent additional for each year of service. In June, 1911, following the strike of 1910, the maximum rate was 23 cents an hour. The increase has come through the setting apart of a certain percentage of the company's income.

At a meeting of the special committee of the National Association of Railway Commissioners, held in Chicago on June 28, it was decided that the state commissions would furnish all assistance possible to the Interstate Commerce Commission in its work of appraising railway property. The statistics in possession of the state commissions relative to the physical valuation of railways will be placed at the disposal of the commission's valuation engineers, and representatives of the different commissions will attend meetings of these engineers. The meeting was attended by commissioners representing the states of Wisconsin, Ohio, Iowa, Oklahoma, Minnesota, Kansas, Illinois, Michigan and Nebraska.

Elisha Lee, chairman, representing the forty-five Eastern railroads to which were presented the demands of the conductors and trainmen last May, asking for a 20 per cent. increase in wages, has issued a brief notice to the public, calling attention to the fact that the roads have refused to grant the increases and that the conductors and the trainmen are now taking a strike ballot. These men, who ask for 17 millions of dollars now, received 30 millions in 1910. The conductors and the trainmen were the first to receive an advance in pay in the cycle of increases which was completed two months ago, when the firemen received an increase of some 10 per cent. The conductors and trainmen, following the example of the enginemen and the firemen, offered to arbitrate "under the law." The railroads, acting in conjunction with brotherhood leaders, are now endeavoring to have Congress amend the law, under which questions of wages on interstate railroads may be adjusted, by providing for more than three arbitrators in each case.

W. F. M. Goss, dean and director of the College of Engineering, University of Illinois, has been elected chief engineer of the Chicago Association of Commerce committee for the investigation of smoke abatement and electrification of railway terminals, to succeed the late Horace G. Burt. Dr. Goss will be granted leave of absence from the university for one year, during which time it is believed that the investigation will be completed and a report of the committee's conclusions issued. He has been a member of the committee since its organization

three years ago. Dr. Goss was born at Barnstable, Mass., in 1859, and was educated at the Massachusetts Institute of Technology, at Wabash College and at the University of Illinois. He organized the department of practical mechanics at Purdue University in 1879, and was professor of experimental engineering, dean of the schools of engineering and director of the engineering laboratory at Purdue from 1890 to 1907. He has held his present position at the University of Illinois since September, 1907. He has been president of the Western Railway Club and a member of the principal technical societies; and he has taken an active part in the work of the Master Car Builders' Association. A portrait of Dr. Goss was published in our issue of June 20, 1911, page 1568.

### A Big Disturbance from a Small Accident.

The detention of a train of the Brooklyn Rapid Transit Company on a trestle bridge over Jamaica Bay, between Rockaway Beach and Brooklyn, N. Y., on Sunday night, June 29, is said by the newspapers to have marooned more than 30,000 passengers at Rockaway Beach. Two cars of the train were damaged by fire, which was started by a short circuit, and the bridge itself was somewhat damaged so that no trains could be run until the next morning. A number of passengers, alarmed by the fire, jumped into the bay, but landed in shallow water or mud so that there were no serious bodily injuries. A large number of following trains were stalled on the bridge and passengers had to walk long distances on the trestles in order to find other means of transportation. It was estimated that over 3,000 passengers reached their homes in Brooklyn and Manhattan by way of Jamaica, these crowds passing through Jamaica on street cars between midnight and 3 a. m.

A relief train was sent out but it worked under great difficulties. After the passengers were disposed of, the train crew gave their attention to fighting the flames. Barrels of water, with firepails, were the only fire-fighting appliances at hand.

Thousands of people who had lingered at Rockaway Beach until a late hour were forced to spend the night on the sands. The police station was thrown open to the women and children, and many of the private residences sheltered persons unable to find room in the hotels, which did a rushing business, some of them charging as high as \$5 for a single room. The police reserves of the Rockaway station were called out to maintain order. Several residents who owned motor trucks coined money at the height of the rush by taking people from the beach to Jamaica, charging \$1.50 per passenger for the trip, and loading their vehicles each time. Finally the Long Island Railroad ran a special train from Rockaway Beach to Jamaica by way of Far Rockaway and Valley Stream, which relieved conditions.

### Flood Damages.

Someone in Ohio estimates that the aggregate amount of the losses sustained in that state and in Indiana in consequence of the floods of last March, is more than \$11,000,000, as follows: Baltimore & Ohio, \$3,000,000 (including the C. H. & D.); Big Four, \$2,500,000; Pennsylvania, \$1,640,000; Toledo & Ohio Central, \$200,000; Norfolk & Western, \$526,500; Chesapeake & Ohio, including the Hocking Valley, \$300,000; Erie, \$600,000; Lake Erie & Western, \$300,000; Vandalia, \$342,000; Grand Rapids & Indiana, \$28,000.

The Wheeling & Lake Erie also was a heavy sufferer from the floods, but figures have not been given out.

### The Pennsylvania's Accident Record.

Of Pennsylvania Railroad employees in train service, in 1912, one in 516 were killed; of 61,443 men employed, 119 killed. Seventeen of these were killed in accidents to trains. There were 68,000 men employed in shops and on the tracks, and of this number 166 were killed by accident, none of which was a collision or derailment.

Freight trains on the Pennsylvania ran 32,114,305 miles in 1912, and passenger trains over 40,000,000 miles; and 4 passengers and 17 employees were killed in train accidents. The greatest "safety" problem is to find ways to protect those who won't protect themselves. On the Pennsylvania employees who knowingly take chances are subjected to "surprise tests." Records

of these tests made in 1912, over 1,100,000 of them show that in 99.8 per cent. of the cases there was perfect compliance with rules.

**"The Public Be Pleased."**

The Lehigh Valley has issued a general order instructing passenger conductors to inform passengers at the earliest possible moment of the cause and probable duration of all delays. On receiving information that their trains will be delayed or derailed, they must pass promptly through the trains or arrange for trainmen to do so, announcing this information and advising passengers as to the best means of proceeding on their journey. The order also extends to ticket agents, who must notify passengers and prospective passengers as to the probable duration of all delays.

General Manager T. J. Foley, of the Illinois Central, has issued a similar order. It says, in part: "A passenger train being delayed and cause unknown to passengers is very annoying to them. When passenger trains meet with unusual delays the conductor will make known the cause and probable length of delay. He will also advise the passengers if facilities for communication with friends are convenient."

"After the conductor has notified the passengers of the time they will be delayed, the train must not proceed until such time has elapsed, unless he is positive all the passengers are on the train."

**Automobiles Kill More Than Railroads.**

A statistician of the New York, New Haven & Hartford presents figures to show that the number of people killed and injured in automobile accidents in this country far exceeds the number of persons killed by all the railroads, excluding employees and trespassers. Indeed, in the populous parts of the country he believes that the automobile casualties would probably equal if not exceed that of the railroads, even counting in employees and trespassers.

In the period of six weeks covered by this compilation from April 1 to May 13, there were 1,598 automobile accidents in this country of which record could be obtained, not including grade crossing accidents in which automobiles were hit by trains. In the 1,598 accidents 260 persons were killed, 424 persons seriously injured, and 1,148 persons slightly injured; total killed and injured 1,832. Taking April as an average month and multiplying by 12 would give 2,340 persons killed and 13,624 injured in a year, a total of killed and injured of 15,964.

The report of the Interstate Commerce Commission for the year ending June 30, 1912, shows that, excluding employees and trespassers, the railroads of the country cost the lives of 1,468 persons and injured 14,291. Of passengers alone 270 were killed. There are 248,888 miles of railroad in this country and there were in operation in that year 60,890 locomotives.

For the compilation of automobile accidents records were obtained from every state in the union. A summary for New England and New York follows:

State.	Number of Accidents.	Fatalities.	Serious Injuries.	Minor Injuries.	Total.
Connecticut .....	70	17	16	54	87
Maine .....	3	0	2	1	3
Massachusetts .....	47	10	8	26	44
New Hampshire .....	7	1	1	3	5
Rhode Island .....	60	8	8	40	56
Vermont .....	3	0	1	3	4
<b>Total, New England..</b>	<b>190</b>	<b>36</b>	<b>36</b>	<b>127</b>	<b>199</b>
<b>Total, New York.....</b>	<b>457</b>	<b>91</b>	<b>135</b>	<b>263</b>	<b>489</b>
<b>Total, N. E. and N. Y.</b>	<b>647</b>	<b>127</b>	<b>171</b>	<b>390</b>	<b>688</b>

In the six New England states in these six weeks there were 190 automobile accidents costing the lives of 36 persons and injuring 163. The New York, New Haven & Hartford reported that in ten years only 29 passengers in all lost their lives while traveling on its trains, though these trains covered 158,531,541 miles.

In the country as a whole there were in the six weeks covered 25 automobiles involved in grade crossing accidents, as a result of which 9 persons were killed and 23 persons injured. In 1912, 348 persons were killed and 2,581 injured in New York state in automobile accidents, and 91 persons were killed and 845 injured in New Jersey. The 348 persons killed in New York state exceed the number of passengers killed in a year on all the railroads in the United States.

**Valuation Committees for the Pennsylvania.**

To facilitate the preparation of the necessary data to co-operate with the Interstate Commerce Commission in its valuation of the railways, and to consider the various problems involved, the Pennsylvania system has appointed valuation committees for the Lines East of Pittsburgh, and the Lines West of Pittsburgh, which are authorized to call upon all the departments of the company for any information needed in connection with the work. The committees are composed of the following:

Lines East of Pittsburgh: L. R. Zollinger, engineer, maintenance of way, chairman; E. B. Temple, assistant chief engineer; C. M. Bunting, comptroller; A. W. Gibbs, chief mechanical engineer; F. L. Ballard, assistant solicitor; C. A. Preston, valuation engineer, and secretary of the committee.

For the Lines West of Pittsburgh: W. C. Cushing, chief engineer, maintenance of way, Southwest System, chairman; D. F. Crawford, general superintendent motive power, Pennsylvania Lines; G. C. Urquhart, real estate agent, Pennsylvania Lines; John Hurst, assistant comptroller, Pennsylvania Lines; F. T. Hatch, chief engineer, Vandalia; E. H. Barnes, chief engineer, Grand Rapids & Indiana; W. D. Wiggins, valuation engineer; C. W. Garrett, secretary of the committee.

The valuation engineers are charged with the general administration of the work, under the supervision of their respective committees. A photograph and sketch of Mr. Preston was published in the issue of June 20, page 1589.

**Chicago Terminal Plans.**

The Chicago city council committee on railway terminals has decided to employ John F. Wallace, to make an expert investigation of the various proposed plans for the erection of new railway terminals in Chicago, before passing on the ordinance asked by the roads using the old Union Station to enable the carrying out of their plans for a station between Jackson boulevard, Adams street, Clinton street and the Chicago river. At a meeting of the council on Monday night the committee was authorized to expend \$10,000 for the investigation, but it is said that this is only a preliminary appropriation.

The Union Station Company inserted in all the Chicago papers on Monday last a two-page advertisement headed, "What the Proposed West Side Terminal Means to the People of Chicago." The advertisement included large photographs of various views of the proposed passenger station and the Pennsylvania freight terminals, and quoted resolutions adopted by the Chicago Real Estate Board endorsing the station plan, and an extract from an article written by John F. Stevens, citing objections to a single union station.

**Proposed Electrification of an Austrian Railway.**

It is proposed to electrify the Arlbergbahn, Austria. This railway lies between Bludenz and Landeck, crossing the Arlberg. The average grade on one section is 23.3 per cent., the maximum is 31.4 per cent. There is only one track, except in the tunnel, which has a double track. The total length of the line is 40 miles. As a line of this description is hard to work with steam, especially when the fuel has to be carried from great distances, whilst, on the other hand, there is plenty of water power, it is not surprising that the electrification of the railway should have been frequently proposed during the last 13 years. Until now, however, all the different schemes failed owing to the high cost of the power plant. As the latter has to be extremely powerful in order to be equal to the demands made on it during the season of dense traffic, there would be a great waste during normal traffic, as the excess power could not be sufficiently utilized. The new project for electrification is to remedy this disadvantage. It is proposed to enlarge the power plant already existing for the working of the Mittenwald Railway in proportion to requirements. This power plant is situated at a distance of about four miles south of Innsbruck, using the water power of the Ruetzbach, a tributary of the river Sill.

**Railway Fire Protection Association.**

This is the name which has been chosen by a number of railway officers, interested in fire insurance, for an association which they hope to establish, and concerning which they propose to



have a meeting in Chicago, October 7, for the purpose of arranging a permanent organization. A conference was held in New York City, May 14; and at another meeting, in Washington, June 2, a constitution and by-laws were drafted. The purpose is to promote interest in the best methods of protection against fire and also prevention; and to circulate information and standardize practices. Invitations have been sent to the principal railroads of the United States, Canada and Mexico. The provisional committee consists of the following six men, the first of whom is chairman and the last the secretary: F. H. Elmore, Southern Railway; E. B. Berry, Southern Railway; A. D. Brooks, Illinois Central; B. S. Mace, Baltimore & Ohio; Robert Scott, Atlantic Coast Line; C. B. Edwards, Mobile & Ohio. The office of the Secretary is at Mobile, Ala.

#### The Tinnerns, Etc., Association.

The Railroad Master Tinnerns', Coppersmiths' and Pipe Fitters' Association was organized at a meeting in St. Louis, on June 24, with about 25 charter members, for the purpose of interchanging ideas on shop management and efficiency. At this first annual meeting papers were read on "Railroad Tinware," "Shop Economy," and "Apprentices." Officers were elected as follows: President, C. B. Baker, of the Terminal Railroad Association of St. Louis; first vice-president, J. S. Richards, of Houston, Tex.; second vice-president, W. J. Moffit, of Indianapolis; third vice-president, W. F. Warren, of Chicago; secretary-treasurer, U. G. Thompson, of Danville, Ill.

#### International Electrical Congress, 1915.

A committee of the American Institute of Electrical Engineers is making plans for an international electrical congress to be held at San Francisco in September, 1915, in conjunction with the Panama Pacific International Exposition. The congress will begin September 13; and in the week preceding there will be a meeting of the International Electrotechnical Commission. The secretary of the committee on organization is Dr. E. B. Rosa, Bureau of Standards, Washington, D. C.

#### MEETINGS AND CONVENTIONS.

*The following list gives names of secretaries, dates of next or regular meetings, and places of meeting.*

**AIR BRAKE ASSOCIATION.**—F. M. Nellis, 53 State St., Boston, Mass.  
**AMERICAN ASSOCIATION OF DEMURAGE OFFICERS.**—A. G. Thomson, Boston, Mass. Convention, May 19, 1914, St. Louis.  
**AMERICAN ASSOCIATION OF GENERAL PASSENGER AND TICKET AGENTS.**—W. C. Hope, New York. Annual meeting, October 14-15, Philadelphia, Pa.  
**AMERICAN ASSOCIATION OF FREIGHT AGENTS.**—R. O. Wells, East St. Louis, Ill.  
**AMERICAN ASSOCIATION OF RAILROAD SUPERINTENDENTS.**—E. H. Hartman, St. Louis, Mo.; 3d Friday of March and September.  
**AMERICAN ELECTRIC RAILWAY ASSOCIATION.**—H. C. Donecker, 29 W. 39th St., New York.  
**AMERICAN ELECTRIC RAILWAY MANUFACTURERS' ASSOC.**—H. G. McConaughy, 165 Broadway, New York. Meetings with Am. Elec. Ry. Assoc.  
**AMERICAN RAILWAY ASSOCIATION.**—W. F. Allen, 75 Church St., New York. Next meeting, November 19, 1913, Chicago.  
**AMERICAN RAILWAY BRIDGE AND BUILDING ASSOCIATION.**—C. A. Lichty, C. & N. W., Chicago. Convention, October 21-24, 1913, Montreal.  
**AMERICAN RAILWAY ENGINEERING ASSOCIATION.**—E. H. Fritch, 900 S. Michigan Ave., Chicago.  
**AMERICAN RAILWAY MASTER MECHANICS' ASSOCIATION.**—J. W. Taylor, Old Colony building, Chicago.  
**AMERICAN RAILWAY TOOL FOREMEN'S ASSOCIATION.**—A. R. Davis, Central of Georgia, Macon, Ga. Next convention, July 22-24, Chicago.  
**AMERICAN SOCIETY FOR TESTING MATERIALS.**—Prof. E. Marburg, University of Pennsylvania, Philadelphia, Pa.  
**AMERICAN SOCIETY OF CIVIL ENGINEERS.**—C. W. Hunt, 220 W. 57th St., New York; 1st and 3d Wed., except June and August, New York.  
**AMERICAN SOCIETY OF ENGINEERING CONTRACTORS.**—J. R. Wenlinger, 11 Broadway, New York; 2d Tuesday of each month, New York.  
**AMERICAN SOCIETY OF MECHANICAL ENGINEERS.**—Calvin W. Rice, 29 W. 39th St., New York.  
**AMERICAN WOOD PRESERVERS' ASSOCIATION.**—F. J. Angier, B. & O., Baltimore, Md. Next convention, January 20-22, 1914, New Orleans, La.  
**ASSOCIATION OF AMERICAN RAILWAY ACCOUNTING OFFICERS.**—C. G. Phillips, 143 Dearborn St., Chicago. Annual meeting, May 28, Atlantic City, N. J.  
**ASSOCIATION OF RAILWAY CLAIM AGENTS.**—J. R. McSherry, C. & E. I., Chicago.  
**ASSOCIATION OF RAILWAY ELECTRICAL ENGINEERS.**—Jos. A. Andreucetti, C. & N. W. Ry., Chicago. Annual convention, October 18-24, Chicago.  
**ASSOCIATION OF RAILWAY TELEGRAPH SUPERINTENDENTS.**—P. W. Drew, 112 West Adams St., Chicago.  
**ASSOCIATION OF TRANSPORTATION AND CAR ACCOUNTING OFFICERS.**—G. P. Conard, 75 Church St., New York.

**ASSOCIATION OF WATER LINE ACCOUNTING OFFICERS.**—W. R. Evans, Chamber of Commerce, Buffalo, N. Y. Annual meeting, October 8, Philadelphia, Pa.  
**BRIDGE AND BUILDING SUPPLY MEN'S ASSOCIATION.**—H. A. Neally, Joseph Dixon Crucible Co., Jersey City, N. J. Meeting with American Railway Bridge and Building Association.  
**CANADIAN RAILWAY CLUB.**—James Powell, Grand Trunk Ry., Montreal, Que.; 2d Tuesday in month, except June, July and Aug., Montreal.  
**CANADIAN SOCIETY OF CIVIL ENGINEERS.**—Clement H. McLeod, 413 Dorchester St., Montreal, Que.; Thursday, Montreal.  
**CAR FOREMEN'S ASSOCIATION OF CHICAGO.**—Aaron Kline, 841 North 50th Court, Chicago; 2d Monday in month, Chicago.  
**CENTRAL RAILWAY CLUB.**—H. D. Vought, 95 Liberty St., New York; 2d Thurs. in Jan. and 2d Fri. in March, May, Sept., Nov., Buffalo, N. Y.  
**CIVIL ENGINEERS' SOCIETY OF ST. PAUL.**—L. S. Pomeroy, Old State Capital building, St. Paul, Minn.; 2d Monday, except June, July, August and September, St. Paul.  
**ENGINEERS' SOCIETY OF PENNSYLVANIA.**—E. R. Dasher, Box 704, Harrisburg, Pa.; 1st Monday after 2d Saturday, Harrisburg, Pa.  
**ENGINEERS' SOCIETY OF WESTERN PENNSYLVANIA.**—E. K. Hilea, Oliver building, Pittsburgh; 1st and 3d Tuesday, Pittsburgh, Pa.  
**FREIGHT CLAIM ASSOCIATION.**—Warren P. Taylor, Richmond, Va.  
**GENERAL SUPERINTENDENTS' ASSOCIATION OF CHICAGO.**—E. S. Koller, 226 W. Adams St., Chicago; Wed. preceding 3d Thurs., Chicago.  
**INTERNATIONAL RAILWAY CONGRESS.**—Executive Committee, 11, rue de Louvain, Brussels, Belgium. Convention, 1915, Berlin.  
**INTERNATIONAL RAILWAY FUEL ASSOCIATION.**—C. G. Hall, 922 McCormick building, Chicago.  
**INTERNATIONAL RAILWAY GENERAL FOREMEN'S ASSOCIATION.**—Wm. Hall, 829 West Broadway, Winona, Minn. Next convention, July 15-18, Chicago.  
**INTERNATIONAL RAILROAD MASTER BLACKSMITHS' ASSOCIATION.**—A. L. Woodworth, Lima, Ohio. Annual meeting, August 18, Richmond, Va.  
**MAINTENANCE OF WAY & MASTER PAINTERS' ASSOCIATION OF THE UNITED STATES AND CANADA.**—W. G. Wilson, Lehigh Valley, Easton, Pa.  
**MASTER BOILER MAKERS' ASSOCIATION.**—Harry D. Vought, 95 Liberty St., New York.  
**MASTER CAR BUILDERS' ASSOCIATION.**—J. W. Taylor, Old Colony building, Chicago.  
**MASTER CAR AND LOCOMOTIVE PAINTERS' ASSOC. OF U. S. AND CANADA.**—A. P. Dane, B. & M., Reading, Mass. Annual meeting, September 9-12, Ottawa, Can.  
**NATIONAL RAILWAY APPLIANCE ASSOC.**—Bruce V. Crandall, 537 So. Dearborn St., Chicago. Meetings with Am. Ry. Eng. Assoc.  
**NEW ENGLAND RAILROAD CLUB.**—W. E. Cade, Jr., 683 Atlantic Ave., Boston, Mass.; 2d Tuesday in month, except June, July, Aug. and Sept., Boston.  
**NEW YORK RAILROAD CLUB.**—H. D. Vought, 95 Liberty St., New York; 3d Friday in month, except June, July and August, New York.  
**NORTHERN RAILROAD CLUB.**—C. L. Kennedy, C. & M. & St. P., Duluth, Minn.; 4th Saturday, Duluth.  
**PEORIA ASSOCIATION OF RAILROAD OFFICERS.**—M. W. Rotchford, Union Station, Peoria; 2d Thursday.  
**RAILROAD CLUB OF KANSAS CITY.**—C. Manlove, 1008 Walnut St., Kansas City, Mo.; 3d Friday in month, Kansas City.  
**RAILWAY BUSINESS ASSOCIATION.**—Frank W. Noxon, 2 Rector St., New York. Annual dinner, second week in December, 1913, New York.  
**RAILWAY CLUB OF PITTSBURGH.**—J. B. Anderson, Penna R. R., Pittsburgh, Pa.; 4th Friday in month, except June, July and August, Pittsburgh.  
**RAILWAY ELECTRICAL SUPPLY MANUFACTURERS' ASSOC.**—J. Scribner, 1621 Monardnock Block, Chicago. Meetings with Assoc. Ry. Elec. Engrs.  
**RAILWAY GARDENING ASSOCIATION.**—J. S. Butterfield, Lee's Summit, Mo. Next meeting, August 12-15, Nashville, Tenn.  
**RAILWAY DEVELOPMENT ASSOCIATION.**—W. Nicholson, Kansas City Southern, Kansas City, Mo.  
**RAILWAY SIGNAL ASSOCIATION.**—C. C. Rosenberg, Bethlehem, Pa. Convention, October 14, Nashville, Tenn.  
**RAILWAY STOREKEEPERS' ASSOCIATION.**—J. P. Murphy, Box C, Collinwood, Ohio.  
**RAILWAY SUPPLY MANUFACTURERS' ASSOC.**—J. D. Conway, 2135 Oliver bldg., Pittsburgh, Pa. Meetings with M. M. and M. C. B. Assoc.  
**RAILWAY TEL. AND TEL. APPLIANCE ASSOC.**—W. E. Harkness, 284 Pearl St., New York. Meetings with Assoc. of Ry. Teleg. Sups.  
**RICHMOND RAILROAD CLUB.**—F. O. Robinson, Richmond, Va.; 2d Monday except June, July and August.  
**ROADMASTERS' AND MAINTENANCE OF WAY ASSOCIATION.**—L. C. Ryan, C. & N. W., Sterling, Ill. Convention, September 8-12, 1913, Chicago.  
**ST. LOUIS RAILWAY CLUB.**—B. W. Frauenthal, Union Station, St. Louis, Mo.; 2d Friday in month, except June, July and Aug., St. Louis.  
**SIGNAL APPLIANCE ASSOCIATION.**—F. W. Edmonds, 3868 Park Ave., New York. Meetings with annual convention Railway Signal Association.  
**SOCIETY OF RAILWAY FINANCIAL OFFICERS.**—C. Nyquist, La Salle St. Station, Chicago.  
**SOUTHERN ASSOCIATION OF CAR SERVICE OFFICERS.**—E. W. Sandwich, A. & W. P. Ry., Montgomery, Ala.  
**SOUTHERN & SOUTHWESTERN RAILWAY CLUB.**—A. J. Merrill, Grant bldg., Atlanta, Ga.; 3d Thurs., Jan., March, May, July, Sept., Nov., Atlanta.  
**TOLEDO TRANSPORTATION CLUB.**—J. G. Macomber, Woolson Spice Co., Toledo, Ohio; 1st Saturday, Toledo.  
**TRACK SUPPLY ASSOCIATION.**—W. C. Kidd, Ramapo Iron Works, Hillsburn, N. Y. Meeting with Roadmasters' and Maintenance of Way Association.  
**TRAFFIC CLUB OF CHICAGO.**—W. H. Wharton, La Salle Hotel, Chicago.  
**TRAFFIC CLUB OF NEW YORK.**—C. A. Swope, 290 Broadway, New York; last Tuesday in month, except June, July and August, New York.  
**TRAFFIC CLUB OF PITTSBURGH.**—D. L. Wells, Erie, Pittsburgh, Pa.; meetings monthly, Pittsburgh.  
**TRAFFIC CLUB OF ST. LOUIS.**—A. F. Versen, Mercantile Library building, St. Louis, Mo. Annual meeting in November. Nooney meetings October to May.  
**TRAIN DESPATCHERS' ASSOCIATION OF AMERICA.**—J. F. Mackie, 7042 Stewart Ave., Chicago.  
**TRANSPORTATION CLUB OF BUFFALO.**—J. M. Sells, Buffalo; first Saturday after first Wednesday.  
**TRANSPORTATION CLUB OF DETROIT.**—W. R. Hurley, L. S. & M. S., Detroit, Mich.; meetings monthly.  
**TRAVELING ENGINEERS' ASSOCIATION.**—W. O. Thompson, N. Y. C. & H. R., East Buffalo, N. Y. Annual meeting, August, 1913, Chicago.  
**UTAH SOCIETY OF ENGINEERS.**—R. B. Keichum, University of Utah, Salt Lake City, Utah; 3d Friday of each month, except July and August.  
**WESTERN CANADA RAILWAY CLUB.**—W. H. Rosevear, P. O. Box 1707, Winnipeg, Man.; 2d Monday, except June, July and August, Winnipeg.  
**WESTERN RAILWAY CLUB.**—J. W. Taylor, Old Colony building, Chicago; 3d Tuesday of each month, except June, July and August.  
**WESTERN SOCIETY OF ENGINEERS.**—J. H. Warder, 1735 Monardnock Block, Chicago; 1st Monday in month, except July and August, Chicago.

# Traffic News.

Railways operating in Iowa have decided to contest the validity of the law passed by the last session of the legislature providing for a maximum fare of 1½ cents per mile in each direction, for the transportation of passengers to county fairs and other gatherings where the attendance is 75,000 or more.

Commissioner Kennish, of the Missouri Public Utilities Commission, has rendered a ruling that free transportation over Missouri railways, except that allowed by the new utilities law, will become invalid on July 31, although issued before that date. The ruling applies to passes which may have been issued for services or in place of money compensation.

According to a press despatch from El Paso, Tex., a traffic agreement has been made between the Southern Pacific, the Kansas City, Mexico & Orient, and the Missouri Pacific, by which through freight between the Missouri river and the Pacific coast will be taken over the K. C. M. & O. This road connects with the Southern Pacific at Alpine, 223 miles east of El Paso, and with the Missouri Pacific at several points.

The Southern Railway, through its Live Stock Department, has issued a booklet entitled, "Hog Production and Conditions for Success in the South," a copy of which will be furnished on request by F. L. Word, Live Stock Agent, Atlanta. The booklet contains practical and valuable information for farmers as to care of hogs, selection of breeds, etc. The South consumes more pork and raises less than any other part of the United States despite the fact that pork can be produced more cheaply in the South than in the North or West.

The Western Maryland now runs trains through, to and from Chicago, the connection from Connellsville, the western terminus of the Western Maryland, being over the Pittsburgh & Lake Erie and the Lake Shore & Michigan Southern. The Chicago Limited express leaves Baltimore at 9:25 a. m. and reaches Chicago at 7:59 a. m.; the Baltimore Limited leaves Chicago at 8:20 p. m. and reaches Baltimore at 7 a. m. Good through connections are made also by trains leaving Baltimore in the evening and Chicago in the morning.

Among the non-railroad organizations which are helping the farmers is the Kansas Bankers' Association, which has formed a special committee to organize bankers, in each county of the state, into county associations, with a view to assisting the farmers in their efforts to introduce scientific farming. The scheme of the bankers includes a plan for lending money for use in experiments.

In Hampden county, Massachusetts, the Hampden County Improvement League has been organized and has established an office in Springfield, which, with the aid of representatives of the Massachusetts Agricultural College, will be made to serve as a headquarters from which agents will go out to travel around the county, to give advice to the farmers. John A. Scheuerle is the secretary of the League. On one day of each week the field workers will be at the office in Springfield to consult with farmers and other visitors.

## Car Balance and Performance.

Arthur Hale, chairman of the committee on relations between railroads of the American Railway Association, in presenting statistical bulletin No. 148 covering car balances and performances for March says:

The miles per car per day, for March were 23.7, compared with 24.7 in February. This figure for March, 1912, was 24.5.

Ton miles per car per day, for March were 374, compared with 395 in February. This is a decrease of 3.86 per cent. compared with March, 1912; the ton miles per car per day, for March, 1912, being 389.

The proportion of home cars on line increased one point to 53 per cent. in March. This figure for March, 1912, was 50 per cent.

The per cent. of loaded mileage for March decreased 0.1 per cent. to 70.0 per cent. This figure for March, 1913, was 71.0 per cent.

The average earnings per car per day for all cars on line were

CAR BALANCE AND PERFORMANCE IN MARCH, 1913.

	New England	N. Y., N. J., Del., Md., Eastern Pa.	Ohio, Ind., Mich., Western Pa.	Va., W. Va., No. and So. Carolina.	Ky., Tenn., Miss., Ala., Ga., Fla.	Iowa, Ill., Wis., Minn.	Mont., Wyo., Neb., Dakotas.	Kan., Colo., Okla., Mo., Ark.	Texas, La., New Mex.	Ore., Idaho, Nev., Cal., Ariz.	Canadian Lines.	Grand Total.
Revenue freight cars owned	89,366	681,104	220,886	189,142	161,856	421,552	18,274	144,004	29,301	135,591	121,201	2,212,277
Average number of system cars on line	42,221	340,074	112,347	97,359	69,932	266,761	4,741	65,534	18,379	60,821	78,143	1,156,312
Railway-owned cars: Average foreign on line	55,526	308,789	112,306	92,693	78,349	170,300	11,898	70,142	22,234	49,189	51,925	1,023,151
Total Railway-owned cars on line	97,547	648,863	224,653	190,052	148,281	437,061	16,639	135,676	40,613	110,010	130,068	2,179,463
Excess	8,181	*32,241	3,767	910	*13,575	15,509	*1,635	*8,328	11,312	*25,581	8,867	*32,814
Per cent. of cars on line to total owned	47	50	51	51	43	63	26	46	63	45	64	53
Home	62	45	51	49	49	41	65	44	76	36	43	46
Foreign	109	95	102	100	92	104	91	90	139	81	107	99
All railways	3,651	35,563	10,310	6,424	8,782	14,759	1,744	7,902	3,853	12,126	3,124	108,238
Total, all cars on line	101,198	684,426	234,963	196,476	157,063	451,820	18,383	143,578	44,466	122,136	133,192	2,287,701
No. of freight engines owned	6,06	5,55	8,86	5,70	9,01	5,77	6,35	7,32	6,04	5,66	5,01	6,40
Average cars on line per freight engine owned	1,460	10,388	3,162	3,468	2,778	6,968	545	2,850	859	2,783	1,934	37,195
Total freight car mileage	69	66	74	57	57	65	34	50	52	44	69	62
Average mileage per car per day	57,820,429	507,010,550	140,846,922	144,121,738	124,652,137	323,280,570	24,215,409	99,401,659	37,542,000	118,629,332	95,311,153	1,672,831,879
Per cent. loaded mileage	18.4	23.9	19.0	23.7	23.6	43.4	27.6	23.6	23.1	31.3	23.1	23.7
Ton-miles of freight, including company freight	73.6	67.4	70.9	68.5	72.5	71.1	76.4	68.3	63.2	69.9	78.5	70.0
Average ton-miles, including company freight:	689,294,703	8,442,913,132	2,275,375,654	2,333,640,892	1,867,708,385	3,861,703,325	370,161,198	1,392,077,643	394,278,540	1,765,336,678	1,728,806,991	25,121,297,141
Per car-mile	11.9	16.7	17.0	16.2	15.1	15.2	15.8	14.0	12.6	15.1	18.1	15.8
Per loaded car-mile	16.2	24.7	23.9	23.6	20.8	21.6	20.6	20.7	19.5	21.7	23.1	22.7
Per car per day	220	398	323	383	388	350	685	330	348	473	419	374
Gross freight earnings:	\$7,110,190	\$47,983,259	\$12,945,010	\$14,431,731	\$12,380,094	\$33,632,184	\$2,715,828	\$11,664,490	\$3,934,478	\$16,836,367	\$10,739,990	\$174,373,621
Average daily earnings: Per car owned	\$2.57	\$2.27	\$1.89	\$2.46	\$2.47	\$2.57	\$4.79	\$2.56	\$4.33	\$4.02	\$2.86	\$2.54
Per railroad car on line	2.35	2.30	1.86	2.45	2.69	2.48	5.27	2.85	3.13	4.06	2.66	2.59
All cars on line	2.27	2.26	1.78	2.37	2.54	2.40	4.77	2.71	2.85	4.58	2.60	2.47

\*Denotes deficiency.

\$2.47, compared with \$2.54 in February. This figure for March, 1912, was \$2.57.

The table on page 29 gives the car balance and performance in the month covered by the report and the diagram shows

lars' worth passed from the eastern coast to the western coast of the United States and Hawaii, and 12 million dollars' worth to foreign countries, while 39 million dollars' worth of products of the Pacific coast and Hawaii moved eastward to the Atlantic

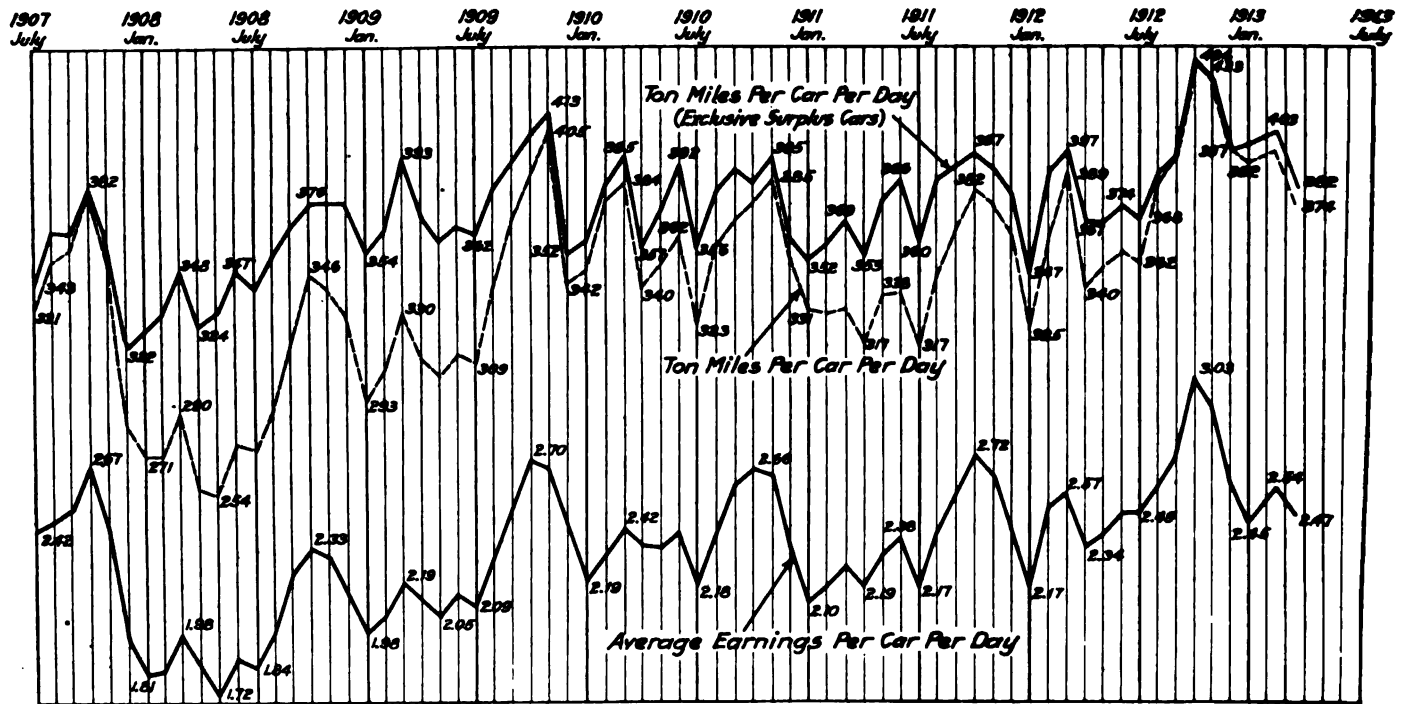
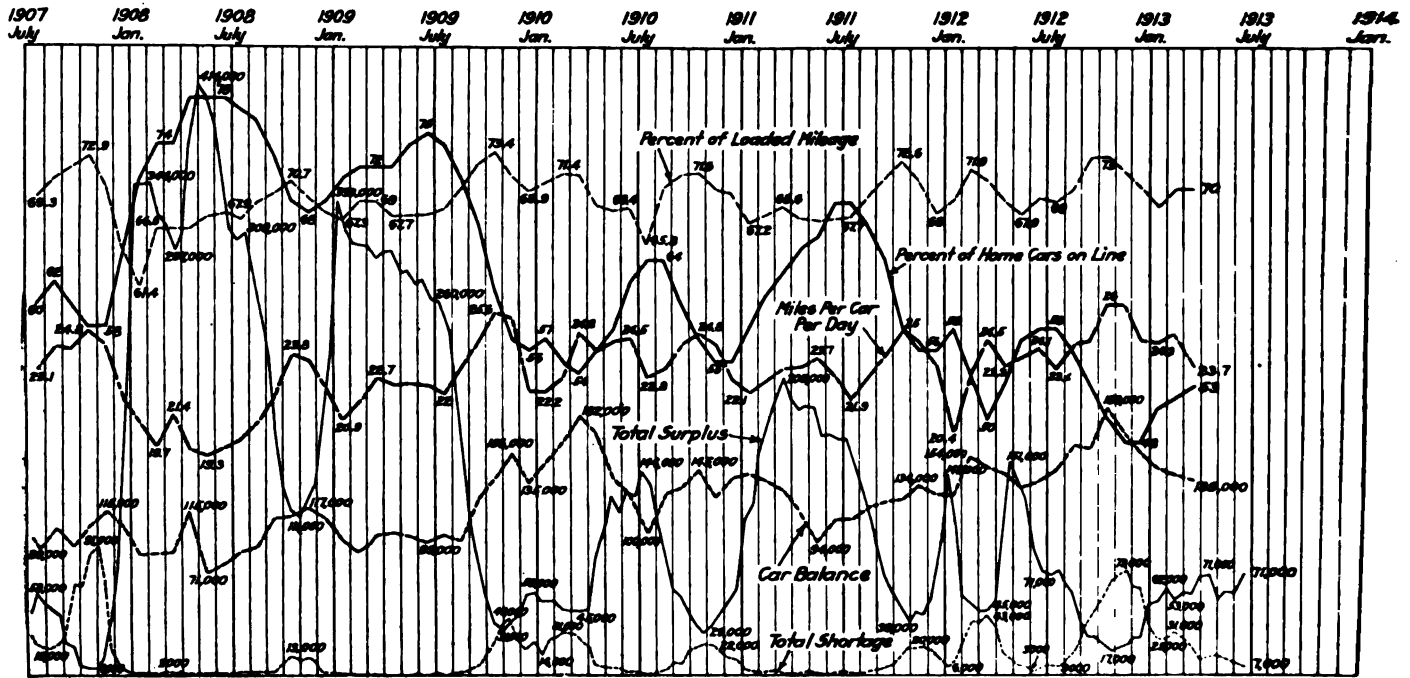

Freight Car Mileage, Earnings and Performance, 1907 to 1913.

car earnings and car mileage and different car performance figures monthly from July, 1907.

**Traffic Over the Isthmus of Panama.**

The Department of Commerce reports the value of freight carried over the Tehuantepec and Panama railroads during the twelve months ending June 30, as 132 million dollars, a decrease of about 10 millions as compared with 1912. No tonnage figures are reported, but it is said that the decrease in value is largely due to lower prices of sugar from Hawaii, which moves in large volume over the Tehuantepec Railroad. In westbound traffic the total is 5 millions greater in 1913 than in 1912. Of the merchandise crossing the isthmuses in 1913, 75 million dol-

and gulf ports of the United States and 5½ million dollars' worth to foreign countries. The remarkable growth in this transisthmian traffic has occurred chiefly since the opening of the Tehuantepec Railroad January 1, 1907. The goods carried over the Panama Railroad in 1906 were valued at only \$6,000,000.

**98,000,000 Feet of Timber.**

Bids have been received by the Forest Service at Washington for 300 million feet of timber which has been advertised for sale on the Tongass National Forest in Alaska, and an additional 300 million feet from the same forest has been applied for. A large part of this timber is Sitka spruce, which will be made into paper

pulp for the Pacific Coast and the Orient, and for the general pulp market.

The latest estimates available show that there is a stand of approximately 70 billion feet of timber on the Tongass National Forest and approximately 28 billion feet on the Chugach National Forest in Alaska. When timber is sold the government allows a cutting period of twenty years, with two years additional for construction work. The prices may be adjusted at five-year intervals to take care of possible advances in lumber values.

#### 14,313,015 Bales of Cotton in 1912.

The Census Bureau calculates that the cotton crop of the United States for 1912 was the second largest ever produced and amounted to 14,313,015 bales of 500 lbs. each. The figures show a slight increase over the preliminary statistics announced March 20. Seed was produced to the extent of 6,104,000 tons, of which 4,579,508 tons were taken by the oil mills, leaving 1,524,492 tons for planting, export, feeding and other purposes.

The 1912 crop graded "middling to strict middling," and the average price of upland cotton was 12.05 cents per pound. Insect pests seriously affected the crop, growers in a large section having to contend with the boll weevil, cotton caterpillars and grass worms. The boll weevil area showed considerable extension, but work by the federal and state agricultural departments is greatly reducing the destructiveness of the pest.

### INTERSTATE COMMERCE COMMISSION.

#### Washington, D. C., Discriminated Against.

*Washington, D. C., store-door delivery. Opinion by Commissioner Marble:*

For many years store-door delivery of certain classes of property transported from designated points has been given at Baltimore, Md., and Washington, D. C. The carriers now propose to withdraw this service at Washington and to continue it at Baltimore. The commission decided that the service must be continued at Washington so long as it is continued at Baltimore. (27 I. C. C., 347.)

#### Rates on Corn Milled at Oneonta, N. Y.

*In re investigation and suspension of new milling-in-transit regulations applicable on the products of corn milled or mixed at Oneonta, N. Y. Opinion by Commissioner Clements:*

Under present tariffs corn with other grain originating at Chicago may be milled at Oneonta, N. Y., on the Delaware & Hudson, on basis of the joint through rate on the product from Chicago to final destination. By the tariff under suspension the Delaware & Hudson proposes to cancel this basis of transit rates on corn when its products are forwarded from Oneonta to points on the Boston & Maine, which would have the effect of increasing the basis of charge on such grain to the combination of the local rates to and from Oneonta. The proposed change was not found to be justified and the commission ordered the suspended tariff cancelled. (27 I. C. C., 367.)

#### Banana Rates Reduced.

*Topeka Traffic Association v. Alabama & Vicksburg et al. Opinion by Chairman Clark:*

The commission found that the present rate of 80 cents per 100 lbs. for the transportation of bananas from New Orleans, La., to Topeka, Kan., is unjustly discriminatory to the extent that it exceeds the rate contemporaneously applied on like traffic from New Orleans to Lincoln or Beatrice, Neb., which is 71 cents per 100 lbs., and that the rate of 70 cents per 100 lbs. for the transportation of bananas from Galveston, Tex., to Topeka is unjustly discriminatory to the extent that it exceeds the rate contemporaneously maintained to Beatrice or Lincoln, which is 62 cents per 100 lbs. Those rates were prescribed for the future. (27 I. C. C., 428.)

#### Rates on Lumber Reduced.

*Cherokee Lumber Co., et al., v. Atlantic Coast Line, et al. Opinion by the commission:*

The complainants alleged that the local and proportional rates

of the initial carrier on lumber from their mills at points on the Atlantic Coast Line between Fayetteville and Wilmington, N. C., to Norfolk, Pinners Point, Portsmouth, Petersburg and Manchester, Va., are unreasonable to the extent that they exceed the rates from certain competitive points. Reparation is asked. The present rates from points on the Atlantic Coast Line south of Fayetteville to the Virginia stations in question is 10.5 cents per 100 lbs. The rates from points on the same railroad north of Fayetteville on the Sanford line is 9 cents per 100 lbs. The commission decided that this practice was discriminatory and ordered the defendants to maintain rates from the points between Fayetteville and Wilmington to the Virginia cities in question which shall be no higher for equal distances than those contemporaneously maintained to the same destinations from points between Sanford and Fayetteville. No reparation was awarded. (27 I. C. C., 438.)

#### Rates on Tin Cans, Petroleum, and Other Commodities.

*In re investigation and suspension of advances in rates by carriers for the transportation of tin cans and other commodities between points in the state of California and points in other states. Opinion by Commissioner McChord:*

The commission decided that the proposed advances on tin cans, grape, berry and fruit baskets and empty carriers, returned between California and other points in other states, had not been justified. The present rates will continue in effect, pending the establishment of a reasonable adjustment.

The tariffs also provide for the transportation of petroleum, crude oil, petroleum gas oil, petroleum road oil, petroleum stove oil, petroleum residuum and fuel oil, under class D instead of under fifth class, when shipped in straight carloads. While under this arrangement the rate on carload shipments is reduced, the elimination of the mixing privilege makes some advances possible when mixed carloads are shipped. The complainants offered no particular objection to this item, and in view of the material reductions it provides, the commission permitted it to become effective without prejudice to any attack that might hereafter be made upon the charges resulting from the elimination of the mixing privilege. (27 I. C. C., 298.)

#### Conference Rulings.

The following rulings have recently been adopted by the Interstate Commerce Commission in conference:

A person who has a contract to furnish ties to a railroad may not lawfully use free transportation as inspector of those ties.

Conference ruling 258, which provides for a time limit of 30 days within which uncollected undercharges may be brought to the attention of the commission for authorization of waiver of such undercharges, was amended to extend the time limit to 90 days.

Officers and employees of the Panama Railroad are government employees and not entitled to free passes from other railroads.

Paragraph 1,863 of the Commission's Regulations for the Transportation of Dangerous Articles by Freight was amended to read as follows: When cylinders containing inflammable gases are not boxed or crated for shipment, the safety device and discharge valve must be made safe from injury during transit by a design and construction of the cylinder or they must be protected by strong metal caps that cannot be detached by rolling the cylinder. Carload or large less-than-carload lots loaded by the shipper to be unloaded by the consignee, may be transported without crating or boxing, provided the cylinders are loaded compactly in an upright position and are securely braced to prevent any relative movement during transit, according to the general methods prescribed by B. E. pamphlet No. 6 for bracing shipments of explosives.

Shipper liable for his error in marking his l. c. l. shipments. Besides being expressly so provided in the rules of all freight classifications it is on broad general grounds the duty of a shipper correctly to mark packages of less than carload freight intended for transportation; and when so marked the carrier is held to a strict responsibility for their safe delivery at destination. In a case where a package of merchandise was addressed by the shipper to Lake City, Fla., instead of Lake City, S. C., it is held, that the shipper making the error must bear the burden of the resulting freight charges; and the fact that

the correct address was noted on the bill of lading is not material. *Parlin & Orendorf Plow Co. v. U. S. Express Co.*, 26 I. C. C., 561, reaffirmed.

#### Missouri River-Illinois Wheat and Flour Rates.

*In re investigation and suspension of advances in rates by carriers for the transportation of wheat from Kansas City, Mo., and other points, to Edwardsville, Ill., Lawrenceville, Ill., and other points. Opinion by Commissioner Meyer:*

The rate schedules under suspension propose to cancel joint rates on grain from the Missouri river to milling points in southern Illinois. Should the proposed cancellation become effective southern Illinois country mills would be placed at a disadvantage as compared with mills at St. Louis and similar rate-breaking points in the movement to seaboard and southern territory.

The commission found that the rates involved must be considered as parts of the total transportation charge from western grain fields to seaboard and southern territory. Southern Illinois millers should be treated upon a substantial equality with St. Louis on the movement to the east and to the south.

An advance in the total transportation charge to these mills cannot be predicated upon a dispute regarding divisions.

If the breaking of rates is to be restricted to St. Louis and other river crossings and so-called primary markets, the substantial equality above indicated must be provided by milling-in-transit provisions or otherwise for all mills along the direct route to the East and to the South. An alternative is to eliminate the proportional and reshipping rates and establish through rates from the grain fields.

Unless the carriers file tariffs providing milling in transit at a charge not to exceed one-half cent per 100 lbs. in connection with rates from East St. Louis to the seaboard, or otherwise provide for the rate relationship above indicated, suspension of the schedules which provide for the cancellation of the 9-cent rate will be made permanent. The schedules providing for the cancellation of the 13-cent rate to Illinois Central points were permanently suspended. (27 I. C. C., 286.)

#### Rates on Spokes Reduced.

*Eastern Wheel Manufacturers' Association et al. v. Alabama & Vicksburg. Opinion by Commissioner Meyer:*

Complaint is made against the assessment of charges higher than the lumber rates for the shipment of club-turned spokes originating south of the Potomac and Ohio rivers and in the southwest to points in Trunk Line territory and also to points south of the Ohio and the Potomac and in the Southwest. A large number of wood articles analogous to club-turned spokes move at the lumber rate. Spoke manufacturers compete with manufacturers of lumber and other wood articles in the purchase of stumpage. Certain spoke manufacturers in the South enjoy lower rates to the East than competing manufacturers in the same section and on the same railway lines. The rates to the East are almost uniformly higher than the lumber rates, while those to the West are in most instances the same.

The commission decided that the saving of freight to the consumer and loss of tonnage to the carrier due to the loss in weight in the manufacture of club-turned spokes from the rough billet is not a valid reason for increased ratings. It is unjust, unreasonable, and discriminatory to force club-turned spokes to bear higher rates than are imposed for a like service upon the many analogous wood articles which move at lumber rates.

The commission found also that the defendant's tariffs show great lack of uniformity in the manner of publishing rates on club-turned spokes and in the relation of those rates to the rates on lumber. This situation should be remedied and the change should be toward greater uniformity. Rough lumber and finished products should not be given the same rating. The differentiation, however, must be based upon correct principles of classification. The suggestion is submitted that the three classification committees publish a uniform lumber list, fixing a proper rate relationship between manufactured articles and the rough lumber from which they are made.

The commission ordered that in future the rates on club-turned spokes should not exceed the rates on oak and hickory lumber between the points in question. (27 I. C. C., 370.)

#### Joint Rate with the Chicago, Zeigler & Gulf Cancelled.

*In re investigation and suspension of advances in rates by carriers for the transportation of coal and other commodities between Zeigler, Ill., and points in Missouri, Iowa and other states by cancellation of joint rates in connection with Chicago, Zeigler & Gulf. Opinion by Chairman Clark:*

In this case the respondents proposed to withdraw joint rates on coal and other commodities in connection with the Chicago, Zeigler & Gulf between Zeigler, Ill., and various interstate points. On protest of the latter road the tariffs were suspended. In determining whether the road in question was a common carrier or a plant facility the commission found that it originated in the necessity to provide means to operate the Zeigler coal mines and that substantially all its mileage is the necessary adjunct of a coal company and its high cost of construction was mainly due to the filling and grading required to transform a level prairie into a gravity yard. The commission found also that it was a common carrier to none but its only patron, the mining company; also that it had no equipment in which to carry interstate commerce. If the mining company ceased operation it is plain that the railroad would likewise be dormant. The commission decided that the service performed by the road in drawing empty cars from the sidings of the line haul carriers to the mine and removing the loaded cars therefrom is private transportation. Necessarily, therefore, it may not be the recipient of divisions from joint through interstate rates on such traffic. As it is not the owner of the coal transported it may not receive an allowance for the services rendered. The allowance or division which is now received constitutes unjust discrimination against other mines served by the connecting railroads. An allowance to the Zeigler Coal Company or its lessee, the mining company, would subject other mines served by the respondents, where the circumstances and conditions are substantially similar to those at Zeigler, to undue prejudice and disadvantage. The order of suspension was vacated. (27 I. C. C., 353.)

#### Reparation on Lumber Shipments.

*Commercial Club of Omaha v. Anderson & Saline River Railway Company et al; and 17 other cases disposed of in the report itself or the orders entered herein, wherein the parties are named, as follows: 3,501 and intervening petition No. 1; 3,515 and amendments Nos. 1 to 13; 3,533 and intervening petitions Nos. 1 and 2; 3,534 and amendment No. 1; 3,573 and sub-No. 1; 3,656 and sub-Nos. 1 to 13; 3,657 and sub-No. 1; 3,658 and sub-Nos. 1 to 107; 3,659 and sub-Nos. 1 to 52; 3,665 and sub-No. 1; 3,683 and sub-Nos. 1, 2 and 3; 3,695 and sub-Nos. 1 to 8; 3,790; 3,795 and sub-No. 1; 3,930; 3,940 and sub-Nos. 1 to 40, and 3,999. Opinion by Chairman Clark:*

In *Commercial Club of Omaha v. Anderson & Saline River et al*, 18 I. C. C., 532, mentioned in the *Railway Age Gazette* of July 1, 1910, page 49, the commission decided that the rates on lumber from southern producing territory to Omaha, Neb., and Des Moines, Ia., were unreasonable, prescribed reasonable rates for the future and awarded reparation.

In the present case awards of reparation, based on the decision in the above case, are sought. The commission held that a complaint filed by an association on behalf of certain of its members who are named, and a finding the complainant's members are entitled to reparation does not include members of the association other than those named in the complaint. The mere submission of an expense bill to the commission is not proof of damage. In this case there was no record upon which the proper relationship of rates as between different groups of origin on the Kansas City Southern can be determined. The rates to Omaha, Lincoln and Des Moines having been found to be unreasonable, shipments made to those points and rebilled therefrom are, for the purpose of determining as to reparation, to be considered as having been made to those basic points locally. Where a consignee pays freight charges to the carrier and then deducts the amount thereof from the purchase price due the vendor, the consignee has not been damaged by the freight rate and cannot, therefore, be heard to claim reparation. No reparation may be allowed in a case where it has been found that the industrial road serving a consignor's plant, originating the shipment and receiving an allowance from the carriers was a

plant facility, or was a participant in the joint rate under which the shipment moved. Cases in which allegations of complaint were not substantiated or attempted to be substantiated were dismissed. Reparation was awarded to certain consignors. (27 I. C. C., 302.)

#### STATE COMMISSIONS.

Governor Dunne has signed the bill passed at the recent session of the Illinois legislature providing for the creation of a state public utilities commission, of five members, to receive salaries of \$10,000 a year. The commission takes office January 1, 1914, and will succeed the present railroad and warehouse commission.

#### COURT NEWS.

The Supreme Court of Pennsylvania, in an opinion by Justice Brown, has sustained the constitutionality of the full crew law of that state, which was passed June 19, 1911. The decision follows that of the Supreme Court of the United States, in which similar laws in Arkansas and Indiana were sustained.

Judge Wright of the United States district court at Danville, Ill., on June 30, issued an order restraining the Illinois Railroad & Warehouse Commission and states' attorneys in eight counties traversed by the Louisville & Nashville in Illinois from enforcing the headlight law passed by the Illinois legislature.

In the Federal Court, New York City, June 26, the Grand Jury indicted eight men connected with well-known commission houses for fraud and collusion in presenting claims to railroads for damages to eggs in transit, the charges including averments that inspectors of the railroads had been parties to the fraud. The accused men were released on bail bonds ranging from \$2,000 to \$3,000 each. It is said that some of the fraudulent claims were for sums 50 per cent. larger than the actual losses in the shipments to which the claims referred.

The prosecuting attorney of Cole county, Missouri, has filed suit in the county circuit court against the Missouri Pacific charging violation of the act passed by the last general assembly requiring the equipment of locomotives with springs under the cabs. The Missouri Pacific immediately applied to the supreme court of the state for a writ of prohibition to prevent the trial of the case, on the ground that the law infringes on the jurisdiction of the Interstate Commerce Commission. The court on June 28 dismissed the application without prejudice.

Attorney-General West, of Oklahoma, has filed a motion in the United States district court to dismiss the injunction restraining the enforcement of the two-cent fare law. A general investigating committee of the lower house of the Oklahoma legislature filed a report severely criticizing the attorney-general for his policy in making a stipulation with the carriers to leave the Oklahoma rate case in statu quo, pending the decision of the Supreme Court, instead of continuing the case. The report stated that the procedure adopted had delayed a settlement. Later, on June 27, at a conference with the attorney-general, the railways agreed to establish 2-cent fares after the first week in July.

The business of the Commerce Court at Washington ceased on June 30, Congress having made no appropriation for the expenses of the court beyond the end of the fiscal year. The four judges, Knapp, Hunt, Garland and Mack, are Circuit judges of the United States, and as such continue to draw salaries, but they have no work to perform. There is still some sentiment in Congress in favor of the continuation of the Commerce Court, and it is possible that an appropriation for another year may yet be passed. Congressman Broussard, of Louisiana, has presented a strong argument in support of the usefulness of the court and calling attention to the fact that the members of the Interstate Commerce Commission desire its continuance. Appeals from decisions of the Interstate Commerce Commission have been settled on the average, by the Commerce Court, in less than half the time formerly taken for such settlement when the cases had to go to the District Courts.

## Railway Officers.

### Executive, Financial and Legal Officers.

E. H. Boles, general attorney of the Lehigh Valley at New York, has been promoted to general solicitor, and his former position has been abolished.

Edson Rich, general attorney of the Union Pacific for Nebraska and Iowa, with headquarters at Omaha, Neb., has also been appointed assistant general solicitor.

J. B. Duke has been appointed auditor of revenue of the Southern Railway, succeeding E. T. Jones, deceased, and T. L. Shelton has been appointed auditor of station accounts, both with offices at Washington, D. C.

C. E. Potts, assistant treasurer of the Chesapeake & Ohio, at Richmond, Va., having retired on July 1, J. A. Hancock, paymaster at Richmond, has been appointed assistant treasurer, succeeding Mr. Potts, and L. G. Burruss, assistant paymaster, succeeds Mr. Hancock.

### Operating Officers.

J. S. Douglas has been appointed chief despatcher of the Atlanta, Birmingham & Atlantic, with office at Manchester, Ga.

Harry Decatur Mudgett, freight conductor, has been appointed trainmaster of the Montana division of the Northern Pacific, with headquarters at Livingston, Mont.

C. J. McDonald has been appointed an assistant superintendent, first division, of the Houston & Texas Central, with office at Austin, Tex., succeeding W. T. Hall, resigned.

In addition to his duties as superintendent of car service of the Chicago & Alton, F. McIntosh is appointed inspector of passenger transportation, with headquarters at Chicago, effective July 1.

R. K. Rochester, division engineer of the Vandalia at Terre Haute, Ind., has been appointed superintendent of the Peoria division, with headquarters at Decatur, Ill., succeeding W. D. Wiggins.

J. T. King, assistant general superintendent of transportation of the Atlantic Coast Line, at Wilmington, N. C., has been appointed general superintendent of transportation, with office at Wilmington.

S. V. Rowland has been appointed trainmaster of the Northern division of the Chicago Great Western, with office at St. Paul, Minn., in place of J. G. Lorton, resigned. The office of assistant superintendent is abolished.

R. C. Watkins, who recently was appointed acting superintendent of the Houston division of the Galveston, Harrisburg & San Antonio, with headquarters at San Antonio, has been appointed superintendent, succeeding J. E. Taussig, resigned to accept service with another company.

R. E. Clark, chief clerk to the assistant general manager of the St. Louis & San Francisco, has been appointed superintendent of car service of the Texas and Louisiana lines, including the New Orleans, Texas & Mexico, Beaumont, Sour Lake & Western, Orange & Northwestern and St. Louis, Brownsville & Mexico, with headquarters at Houston, Tex., succeeding J. H. Reich, resigned.

W. A. Card, superintendent of the Creston division of the Chicago, Burlington & Quincy, with office at Creston, Iowa, has been appointed superintendent of the St. Joseph division, with headquarters at St. Joseph, Mo., succeeding B. B. Greer, who has been transferred to the staff of the general manager, with headquarters at Chicago. Mr. Card is succeeded by N. C. Allen, heretofore assistant superintendent of the Aurora division at Aurora, Ill. A. J. Carter, trainmaster at Aurora succeeds Mr. Allen. Effective July 1.

G. H. Trenary, division superintendent of the Chicago & Eastern Illinois at Salem, Ill., has been appointed superintendent of the Chicago division, with headquarters at Danville, Ill. J. O. Bell, superintendent of the Evansville division at Evansville, Ind., succeeds Mr. Trenary as superintendent of the Illinois division. Mr. Bell is succeeded by E. R. Glidden. J. E. Epler has

been appointed assistant to the general manager in charge of maintenance of equipment, with headquarters at Chicago. The office of assistant to the general manager is abolished. In our issue of last week the name of the road was given as the Chicago & Alton through error.

G. H. Trenary, whose appointment as superintendent of the Chicago division of the Chicago & Eastern Illinois, with headquarters at Danville, is announced elsewhere in these columns,



G. H. Trenary.

was born February 9, 1867. He was graduated from high school at Urbana, Ill., in 1883, and shortly after began railway work as messenger and call boy, learning telegraphy with the Indiana, Bloomington & Western. He was subsequently agent for that road and its successors at various points, and in 1892 became joint agent of the Chicago & Eastern Illinois, Cleveland, Cincinnati, Chicago & St. Louis and Toledo, St. Louis & Kansas City, at Veedersburg, Ind. Three years later he was made agent of the Chicago & Eastern Illinois, and the following year, in 1896, he became chief clerk to the general superintendent of that road. Mr. Trenary was promoted to division superintendent at Brazil, Ind., in July, 1899, and in November, 1904, was transferred to St. Elmo, Ill., in a similar capacity. He remained at that place until July, 1911, when he was made superintendent of the Illinois division at Salem, Ill., where he was located when he was appointed superintendent of the Chicago division, with office at Danville, as above noted.

#### Traffic Officers.

Louis F. Klein, general eastern agent of the Illinois Central at New York, has been appointed general eastern agent of the Western Maryland, with headquarters at New York, succeeding Orno M. Brown, resigned.

A. M. Reinhardt, who on June 10, was appointed assistant general freight agent of the Atchison, Topeka & Santa Fe Coast Lines, with headquarters at Los Angeles, Cal., was born



A. M. Reinhardt.

December 1, 1878, at Lawrence, Kan. He was graduated from high school at Hemet, Cal., and began railway work with the Atchison, Topeka & Santa Fe in December, 1895, as messenger and student at San Jacinto, Cal. He was made relief agent of the Los Angeles division in July, 1897, and in September of the following year was transferred to Barstow, Cal., as cashier. From January to June, 1899, he was agent at Temecula, Cal., and the four months following, until November, 1899, he was agent at Perris, Cal. He was then made bill clerk at San Diego, Cal., where he remained until September, 1901, when he went to Hanford, Cal., as agent. From January, 1903, to February, 1906, Mr. Reinhardt was overcharge investigator and rate clerk in the claim department of the auditor's office. He was then until September

of that year rate clerk in the general freight office, when he became chief clerk in the general agent's office at Los Angeles, Cal. On May 1, 1908, he was promoted to chief clerk in the general freight agent's office at that place, which position he held until his recent appointment as assistant general freight agent, as above noted. Mr. Reinhardt's entire railway service of nearly 18 years has been with the Santa Fe Coast Lines.

J. L. Durrett, assistant general freight agent of the Southern lines of the Illinois Central, has been transferred to Louisville, Ky., as assistant general freight agent, and F. C. Furry succeeds Mr. Durrett at Memphis. G. W. Maher has been appointed traveling freight and passenger agent, with headquarters at Seattle, Wash.; J. C. Lindsey, freight and passenger agent at Seattle, has been appointed commercial agent at that place, and the former position is abolished. T. F. Bowes, traveling freight and passenger agent at San Antonio, Tex., has been transferred to Los Angeles, Cal., as traveling freight agent. Effective July 1.

#### Engineering and Rolling Stock Officers.

William Bibby, roadmaster of the Grand Trunk at Allandale, Ont., has been appointed assistant general roadmaster of the Central Vermont, with office at St. Albans, Vt.

William D. Wiggins, superintendent of the Peoria division of the Vandalia, with headquarters at Decatur, Ill., has been appointed valuation engineer of the Pennsylvania Lines west of Pittsburgh, with office at Pittsburgh, Pa.

A. G. Armstrong, division foreman of the Atchison, Topeka & Santa Fe Coast Lines, at Los Angeles, Cal., has been appointed master mechanic of the Arizona division, with headquarters at Needles, Cal., succeeding M. P. Cheney, who is on extended leave of absence.

H. C. Estep, engineer of construction of the Southern New England Railroad Corporation, and the Southern New England Railway Company, having resigned to accept service with another company, the position of engineer of construction has been abolished, and H. A. Phelps has been appointed division engineer of the Southern New England Railway, with office at Providence, R. I., succeeding T. I. Ellis, resigned.

Frank Taylor Hyndman, formerly mechanical superintendent of the New York, New Haven & Hartford, has been appointed superintendent of motive power and cars, of the Wheeling &



F. T. Hyndman.

Lake Erie, with headquarters at Cleveland, Ohio. He was born on September 29, 1858, and began railway work in 1872, as machinist apprentice on the Central of New Jersey at Ashley, Pa., and from 1874 to 1877, was an apprentice in the shops of the Lehigh Valley at Wilkes-barre, then, for about three years, was brakeman and fireman on the Central of New Jersey. From March to November, 1880, he was a machinist on the Atchison, Topeka & Santa Fe at Raton, New Mexico, and from March, 1881, to August, 1883, was machinist on the Pittsburgh & Western and the Pittsburgh Locomotive Works, becoming engineman on the Pittsburgh & Western in August, 1883. He remained in that position until September, 1895, when he was made trainmaster, and from April, 1896, to November, 1902, was master mechanic of the same road at Allegheny. He was then, for one month, master mechanic on the Baltimore & Ohio at Pittsburgh, and from December, 1902 to July, 1904, was master mechanic on the Buffalo, Rochester & Pittsburgh. In July, 1904, he was appointed superintendent of motive power of the same road at Dubois, Pa., and the following November went to the New York, New Haven & Hartford as general master mechanic at New Haven, Conn. He became mechanical superintendent of

the same road in May, 1906, resigning from that position on July 15, 1907, to enter the railway supply business, and at the time of his recent appointment as superintendent of motive power and cars, of the Wheeling & Lake Erie, was the Philadelphia, Pa., representative of S. F. Bowser & Co., Inc., Fort Wayne, Ind.

F. W. Williams, division master mechanic of the Chicago, Rock Island & Pacific at Cedar Rapids, Iowa, has been transferred to Manly, Iowa, as master mechanic of the Minnesota division. C. B. Daily, assistant superintendent of shops at Silvis, Ill., has been appointed master mechanic of the Cedar Rapids division at Cedar Rapids, succeeding Mr. Williams. P. Linthicum, general foreman at Horton, Kan., has been transferred to Silvis in place of Mr. Daily. O. S. Beyer, Jr., succeeds Mr. Linthicum.

W. M. O'Loughlin has been appointed supervisor of signals of the Northern Pacific, in charge of the maintenance of signal apparatus on the lines east of Mandan, N. D., with headquarters at St. Paul, Minn., in place of Wilfred Kearton, resigned. P. McGuire has been appointed assistant roadmaster of the Minnesota division, with office at Staples, Minn. G. C. Chittendon has been appointed roadmaster of the First sub-division, with headquarters at Pasco, Wash., in place of C. C. Blood, transferred. P. E. Anderson has been appointed roadmaster of the Walla Walla and Pendleton branches, with office at Pasco in place of J. G. Cutler, deceased.

**Purchasing Officers.**

J. F. Marshall, purchasing agent of the Wheeling & Lake Erie, has been appointed manager of purchases and supplies of the Chicago & Alton, with headquarters at Chicago, succeeding E. S. Wortham, assigned to other duties.

J. H. Beggs, whose appointment as purchasing agent of the Chicago & Eastern Illinois, with headquarters at Chicago, has already been announced in these columns, entered the construction department of the

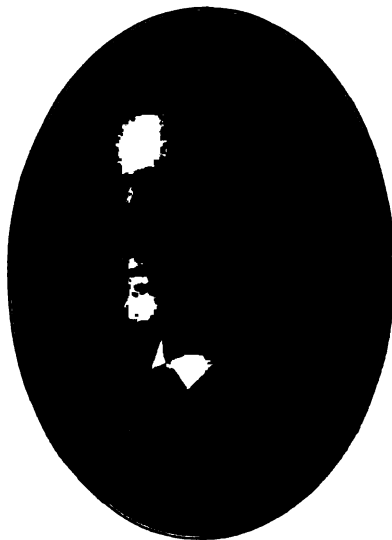

J. H. Beggs.

Atchison, Topeka & Santa Fe at Pueblo, Colo., on May 17, 1887, when that company was building its road into Denver. He was employed as timekeeper, gang foreman and general foreman, and when the road was finished he was transferred to the store department in February, 1888, remaining in that department until March 15, 1896. During this period he was located at Topeka, Kan.; Las Vegas, N. M.; Guaymas, Mex.; Benson, Ariz., and Raton, N. M., filling the positions of assistant storekeeper, storekeeper and fuel agent. Mr. Beggs was

then made chief clerk to the master mechanic at Raton, N. M., and from February, 1902, to July, 1905, he was successively chief clerk to the mechanical superintendent at LaJunta, Colo., and Cleburne, Tex. On the latter date he left the Santa Fe to go to the Chicago & Eastern Illinois as chief motive power clerk at Danville. On February 1 of this year he was promoted to maintenance of equipment accountant, which position he held until he was appointed purchasing agent on June 18, as above noted.

**OBITUARY.**

Thomas J. Fitzgerald, formerly resident engineer of the Southern Pacific at Ogden, Utah, died in that city on June 24, aged 67 years. Mr. Fitzgerald was connected with the Central Pacific and Southern Pacific from October, 1868, until about January, 1912, when he retired owing to ill health and was placed on the pension list of that company.

**Equipment and Supplies.**

**LOCOMOTIVE BUILDING.**

THE CHICAGO & EASTERN ILLINOIS has been authorized by court to buy 4 locomotives.

THE SAN ANTONIO & ARANSAS PASS will soon be in the market for about 10 locomotives.

THE CROFT LUMBER COMPANY has ordered one locomotive from the Baldwin Locomotive Works.

THE MARYSVILLE & NORTHERN has ordered one locomotive from the Baldwin Locomotive Works.

THE INDIANA HARBOR BELT has ordered 8 six-wheel switching locomotives from the Baldwin Locomotive Works.

THE CHILEAN STATE RAILWAYS are in the market for 20 narrow-gage locomotives, 20 broad-gage passenger locomotives, 10 broad-gage switching locomotives and 50 broad-gage freight locomotives.

THE NIGERIAN RAILWAYS OF AFRICA have ordered 8 Mountain type (4-8-2) locomotives from the American Locomotive Company. These locomotives will be equipped with superheaters and will have 18 in. x 23 in. cylinders and 42¾ in. driving wheels. In working order they will weigh 140,000 lbs.

THE SOLVAY PROCESS COMPANY, Syracuse, N. Y., has ordered 1 six-wheel switching locomotive for the Delray Connecting Railway. The dimensions of the cylinders will be 21 in. x 26 in., the diameter of the driving wheels will be 51 in., and the total weight in working order will be 159,000 lbs.

**CAR BUILDING.**

THE CHESAPEAKE & OHIO has ordered 1,000 gondola cars of 115,000 lbs. capacity from the Ralston Steel Car Company for the Hocking Valley.

THE BOSTON & ALBANY is making inquiries for 40 all-steel coaches, 4 all-steel postal cars, 4 all-steel combination passenger and baggage cars and 2 all-steel dining cars.

THE CHILEAN STATE RAILWAYS are in the market for 700 miscellaneous freight cars; for narrow-gage passenger cars as follows: 15 first-class coaches, 10 third-class coaches, 2 auto-motor cars and 7 baggage cars; and for broad-gage passenger cars as follows: 60 first-class coaches, 50 third-class coaches, 6 auto-motor cars, 5 baggage cars and 5 parlor cars.

**IRON AND STEEL.**

GENERAL CONDITIONS IN STEEL.—There has been a slight improvement in buying during the past week, and manufacturers believe that July will show an increase in orders as compared with June. There is more confidence now in the good crop outlook, and this is having its effect on the steel industry. It is highly probable that there will be a considerable curtailment of operations during the summer months, unless the buying improvement takes a distinct turn for the better. The railroads have been making only light purchases, but they are expected to enter the market heavily in the fall.

PROPOSED SPANISH RAILWAYS.—Spanish government railway engineers are in Lugo, Logrono, and Orense examining the land which it will be necessary to take in order to carry out the projects for the construction of three railways. The Ponteverta-to-Lugo Railway runs via Lalin, Province of Pontevedra, and will ultimately be extended to the port of Ribadeo, Province of Lugo, connecting the two ports of Marin and Ribado. The line will run through extremely fertile country, which has been without railway communication. A company to bid on the work when it is let has been formed. On the second line, Pamplona to Estella, it is proposed to build a station and a bridge over the Ebro River at Logrono. The third line will connect the town of Chaves in Portugal with Verin in the Province of Orense in Spain.



## Supply Trade News.

The Union Railroad will use the Murray Keyoke, manufactured by the Keyoke Railway Equipment Company, Chicago, on 296 gondola cars now being built by the Pressed Steel Car Company.

W. E. Jenkinson has been made railroad representative for S. F. Bowser & Company, Inc., Fort Wayne, Ind., covering that territory vacated by E. F. G. Meisinger. In addition, he will take over the Southwestern and Pacific coast territory. He will cover the states from Texas to Oregon.

E. H. Outerbridge, who has been secretary and treasurer and managing director of the Pantasote Company, New York, since its organization, has been made a vice-president and managing director of that company. Raymond Harvey, who has been associated with Mr. Outerbridge for more than ten years, has been made secretary and treasurer of the same company.

The Protectus Paint Company, Philadelphia, Pa., has recently added to its business the sale of the products of the Barber Asphalt Paving Company, New York, particularly as used by railroads and car builders, making a specialty of asphalt insulating and building papers, asphalt felts and other asphalt fabrics, asphalt roofings, asphalt waterproofing compounds and asphalt Mastic for floors.

The Locomotive Arch Brick Company has taken over the patents and business of the Fire Clay Development Company, 1201 Chamber of Commerce building, Chicago. The company has recently been organized with the following officers: President, J. W. Moulding; vice-president, E. P. Stevens; vice-president and general manager, John L. Nicholson; secretary, T. C. Moulding. The Moulding family has been in the fire brick business since 1861, and now owns five large modern plants, for which the Locomotive Arch Brick Company will be the selling agents.

The annual report of the American Car & Foundry Company, New York, for the fiscal year ended April 30, 1913, shows gross earnings of \$5,539,000, an increase of \$1,346,000 over the preceding year. The net earnings were \$3,328,592, an increase of \$489,360, and after the deduction of \$250,000 for maintenance and improvements the balance available for dividends was \$3,078,592. Dividends of 7 per cent. were paid on the \$30,000,000 of preferred stock, and of 2 per cent. on the \$30,000,000 of common stock, leaving a surplus for the year of \$378,592. Added to the previous surplus this makes a total surplus at the close of the fiscal year of \$25,255,168. At the annual meeting of the stockholders on June 26, the retiring directors were re-elected.

### TRADE PUBLICATIONS.

**JEFFERSON UNIONS.**—The Jefferson Union Company, Lexington, Mass., has published a small illustrated folder, telling how both William Tell and Jefferson unions hit the mark.

**GRAPHITE BRUSHES.**—The Joseph Dixon Crucible Company, Jersey City, N. J., has published a small illustrated booklet pointing out the advantages of graphite brushes. Prices are included.

**OIL FUEL BURNERS.**—The Hauck Manufacturing Company, San Francisco, Cal., has devoted an illustrated booklet to its oil fuel burners for use in connection with locomotive and steel car repairs.

**DENVER & RIO GRANDE.**—The passenger department has issued an attractive booklet entitled "Around the Circle," describing a special thousand-mile tour through the Rocky mountains, mainly in the state of Colorado.

**POWER HAMMERS.**—Beaudry & Company, Boston, Mass., has published a small booklet illustrating and describing its power hammers, of which the Champion type is designed for light and heavy railroad, machine, and general forging.

**REFRIGERATOR CARS.**—The Moore Patent Car Company, St. Paul, Minn., has published supplement No. 5, entitled, Perishable Products Transported Scientifically and Economically. This booklet gives the results of some interesting service tests.

## Railway Construction.

**ALEXANDRIA & WESTERN.**—According to press reports this company has given a contract to Henry J. Cox & Co., New Iberia, La., for building the first section of 14 miles. The plan calls for building from Alexandria, La., westerly towards Leesville, and eventually into Texas. The contract recently let calls for the excavation of 70,000 cu. yds. of earth, 50,000 cu. yds. of rock, constructing 2,300 lineal feet of wood trestle and 30,000 lineal feet of piling.

**BIG SANDY & KENTUCKY RIVER.**—An officer writes that the plans call for a line from a point on the Big Sandy division of the Chesapeake & Ohio at Dawkins, Ky., just south of Stafford, via Johnson, Blair, Denver, Patrick, Sherman and Riceville to Licking river, about 35 miles. Track has been laid on 10 miles, and contracts will be let in about 60 days to build a 15-mile section. The company may build a bridge over Licking river, and expects to develop a traffic in coal and forest products. S. N. Fannin, president; W. H. Dawkins, vice-president and general manager, Ashland, Ky., and Cunningham & Conner, consulting engineers, Huntington, W. Va.

**CACHE VALLEY.**—An officer of this company, which operates a line from Sedwick, Ark., northeast to Light, on an irregular schedule, writes that the prospects are fair for building a 20-mile branch east to Paragould, but that the proposed line has not yet been definitely located. The plans call for an extension northeast to Thebes, Ill., 115 miles, and on the southern end southwest to Little Rock, Ark., 120 miles.

**CHICAGO & NORTH WESTERN.**—An officer writes that the St. Louis, Peoria & North Western building from Peoria, Ill., south to Girard, about 90 miles, has tracks laid from the South Pekin Yard to Auburn, about 60 miles, and about 40 miles of the line has been ballasted. Winston Brothers Company, Minneapolis, Minn., did the grading work, and the Cleary-White Construction Company, Chicago, the concrete bridge work. The extension on the south end, known as the Macoupin County Extension Railway, is to be an 8-mile coal spur from Benld, Ill., south to Staunton, thence into Madison county. Winston Brothers Company, Minneapolis, are doing the grading and bridge work. The bridges on this line will be wooden structures. (June 27, p. 1631.)

**CHICAGO, ROCK ISLAND & PACIFIC.**—The St. Paul & Kansas City Short Line has been put in operation for local traffic between Carlyle, Iowa, and Allerton, about 65 miles, a regular train having been put on the first of July. (November 1, p. 861.)

**ELBERTON & EASTERN.**—An officer writes that this road is now in operation from Elberton, Ga., southeast to Tignall, 21.8 miles. An extension is projected from Tignall east to Lincolnton, 18 miles. W. O. Jones, president, and A. Wilson, chief engineer, Elberton. November 22, p. 1013.)

**FORISTELL, CAMP CREEK & NORTHEASTERN.**—Incorporated in Missouri with \$30,000 capital to build from Foristell, St. Charles county, Mo., to Camp Creek, about three miles. The incorporators include H. J. Paddock, E. L. Squire, K. N. Horwitz and C. Garcia.

**GULF, FREEPORT & NORTHERN.**—Incorporated in Texas with \$100,000 capital and headquarters at Freeport. The plans call for building from Freeport northwest through Brazoria, Fort Bend and Austin counties to Sealy, about 80 miles. C. L. Sharp, J. H. Bartlett, Marshall; R. E. Loggins, G. Edwards, Columbia; D. A. Barr, Freeport; W. L. Hall and C. L. Pierce, Damon, are incorporators.

**INTERCOLONIAL RAILWAY.**—Plans for grade improvements and for double tracking the line between Moncton, New Brunswick and Halifax, Nova Scotia, are now under consideration.

**LATOUR CREEK.**—Incorporated in Idaho to build from a point on the Oregon-Washington Railroad & Navigation Company, along Latour creek for about ten miles. It is understood that financial arrangements have been made. L. W. Butler, president; H. Neeligan, secretary-treasurer; A. E. Cowles, F. B. Foltz, of Kellogg, Idaho, and W. Jacques, are directors.

**LXINGTON & EASTERN.**—See Louisville & Nashville.

**LOUISVILLE & NASHVILLE.**—An officer writes that preliminary surveys are being made for an extension of the Lexington & Eastern up Rock House creek in Letcher and Knott counties, Ky. The company has not yet authorized the construction of this extension.

**MACOUPIN COUNTY EXTENSION RAILWAY.**—See Chicago & North Western.

**MOBILE & BALDWIN COUNTY (Electric).**—An officer writes that the company is carrying out all the work except building draw-bridges, with its own men on a line from Mobile, Ala., via Bay Minette, Volanta, Fairhope and Foley, to Pensacola, Fla., and that no contracts will be let. The maximum grades will be 2 per cent., and maximum curvature 4 deg., and when completed there will be five bridges on the line. The plans include putting up shops and office buildings. The company will use gas electric motor cars, and expects to develop a traffic in general merchandise, fruit, vegetables and farm products. W. B. Miller, president, Chicago; M. H. Miller, vice-president and general manager, P. O. Box 928, Mobile, Ala.

**MOBERLY, HUNTSVILLE & RANDOLPH SPRINGS (Electric).**—An officer writes that a contract has been given to the Jennings Construction Company, Joplin, Mo., for grading work from Randolph Springs, Mo., to Moberly, 12 miles, and a contract has been given to Ed. Freed, Moberly, for the concrete work on the same section. C. H. Dameron, president, and John J. Munding, chief engineer, Huntsville. (June 6, p. 1244.)

**MORRISBURG & OTTAWA (Electric).**—Bids are wanted up to July 8, at Ottawa, Ontario, for building 10 miles from Ottawa towards Morrisburg.

**ST. LOUIS, PEORIA & NORTH WESTERN.**—See Chicago & North Western.

**ST. PAUL & KANSAS CITY SHORT LINE.**—See Chicago, Rock Island & Pacific.

**SHELBY COUNTY.**—This company, which operates a ten-mile line from Shelby, Mo., north to Shelbyville, is building an extension, it is said, northwest via Leonard and Cherry Box, to Novelty in Knox county. It is understood that the line is eventually to be extended northwest to a connection with the Atchison, Topeka & Santa Fe.

**WATAUGA & YADKIN RIVER.**—An officer writes that on July 1 this company began operating the line from North Wilkesboro, N. C., where a connection is made with the Southern Railway, west via Minton, Goshen, Marley Ford, Goulds, Elkville and Elkville Junction to Grandin, 20.51 miles. The company's men are now at work building extensions from Grandin, southwest to Lenore, where a connection is to be made with the Carolina & North Western, about 20 miles, also from Elkville northwest via Darby and Boone to Jefferson. There is considerable rock work to be done. Maximum grades to the summit of the Blue Ridge will be 2½ per cent., and maximum curvature 12 deg. There will be about 1,500 ft. of trestles and 1,500 ft. of tunnel work. The company expects to develop a traffic in lumber, iron ore, mica, talc, and farm products. W. J. Grandin, president; H. C. Landon, general manager and chief engineer. (See Yadkin River, October 25, p. 815.)

### RAILWAY STRUCTURES.

**BOWMANVILLE, ONT.**—See Glen Tay.

**BRIGHTON, ONT.**—See Glen Tay.

**COBOURG, ONT.**—See Glen Tay.

**GLEN TAY, ONT.**—An officer of the Canadian Pacific writes that contracts have been given to the J. S. Metcalfe Co., Ltd., Montreal, Que., and work is to be started at once, putting up stations and other structures on the new line between Glen Tay Junction, Ont., and Agincourt, which are 183 miles apart. There will be brick stations with slate roofs and concrete foundations as follows: At Trenton, 23 ft. x 89 ft.; Brighton, 20 ft. x 77 ft. 6 in.; Cobourg, 28 ft. x 109 ft.; Port Hope, 20 ft. x 77 ft. 6 in.; Bowmanville, 20 ft. x 77 ft. 6 in.; Oshawa, 28 ft. x 109 ft., and at Whitby, 20 ft. x 77 ft. 6 in. There will be a number of other structures also put up at these places and at about 20 other points on the line, including wooden stations, ten 40,000-

gal. water tanks, a 12-stall engine house, freight sheds, etc., in all about 85 structures.

**HOBSON, OHIO.**—An officer of the Kanawha & Michigan, writes that a contract has been let for building a new wood-working shop 100 ft. x 200 ft., at Hobson. The building will be of structural steel, covered with corrugated iron.

**NEW YORK.**—The Baltimore & Ohio is building an eight-story, reinforced concrete warehouse in New York, on land bounded by Eleventh and Thirteenth avenues and Twenty-fifth and Twenty-sixth streets, fronting 63 ft. on Eleventh avenue and 352 ft. on Twenty-sixth street; the remaining section of the lot is being prepared for team tracks. The concrete foundations of the warehouse have been completed; these were constructed on piling 80 ft. long, the work necessitated using about 4,000 piles. In driving the piles, great difficulty was encountered, such as sunken barges filled with stone, and three separate bulkheads had to be removed owing to the bulkhead line having been moved out from time to time. All foundation footings and the cellar floor will be waterproof, as the basement level is below high tide. The entire structure will be of reinforced concrete. The floors will have a carrying capacity ranging from 500 lbs. per sq. ft. on the first floor to 150 lbs. per sq. ft. on the top floor. The freight, or first floor will have rock mastic wearing surface and a special concrete with granolithic surface will be used on the other floors. The warehouse will be divided into three compartments with two elevators in each. Fire protection throughout the building will be provided, including a sprinkler system. Tracks will be laid within the warehouse with a capacity of 16 cars and the team tracks outside the house will have a capacity of 60 cars. All driveways will be paved and an electric gantry crane will be installed in the yard for handling heavy freight. Cars will be brought to the bulkhead on car floats. The building will be lighted throughout by electricity. The windows will be of wired glass with metal frames, and all doors will be fireproof. The cost of the freight house will be about \$500,000, exclusive of the land.

**OGDEN, UTAH.**—The Denver & Rio Grande has asked for bids for the erection of a freight depot to cost about \$75,000.

**OSHAWA, ONT.**—See Glen Tay.

**PORT HOPE, ONT.**—See Glen Tay.

**SALT LAKE CITY, UTAH.**—The Denver & Rio Grande has announced that new shops will be erected as soon as possible on the site of the shops destroyed by fire on June 18. Work has already been started on temporary shops.

**TRENTON, ONT.**—See Glen Tay.

**WHITBY, ONT.**—See Glen Tay.

**FLOOD DAMAGE IN NATAL, AFRICA.**—The total cost of repairing the damage done to the railways in the province of Natal by the recent floods, and effecting certain improvements with a view to reducing the possibility of similar damage occurring in future, will be about \$276,250.

**NEW RAILWAY STATION AT PRETORIA, SOUTH AFRICA.**—The new railway station at Pretoria is an exception to the almost general neglect of architecture in South African station buildings. The site is a happy one, as the building terminates a vista of nearly a mile through Market street and Church square to the valley and distant hills on the north. The ground in front of the station has been laid out with formal avenues, fountains and grass lawns, combined with ample space for the street car service and all wheel traffic. The building is three stories in height, built on the outside entirely of flatpan (a sandstone from the Orange Free State). The roof is covered with red "Italian" tiles manufactured at Vereeniging, on the Vaal river and this is the first time these tiles have been used on a public building in South Africa. The roof is crowned by a central clock tower, also of stone. The dominant architectural notes are the arched porte cochere to the main entrance on the ground floor, with a long arcaded loggia on either side, and the deeply recessed columnar features in the center of the three principal facades. The deep overhanging eaves protect the walls and windows from sun and rain. The west elevation contains covered a main exit porch with granite columns.

## Railway Financial News.

**ATLANTA, BIRMINGHAM & ATLANTIC.**—The interest on the \$4,700,000 joint receivers' certificates, which certificates matured July 1, was paid, but the principal was not paid. The following protective committee has been formed: Howard Bayne, George C. Clark, Jr., Harold Benjamin Clark, Lewis B. Franklin and Carl E. Steere, with G. E. Warren, secretary.

**CANADIAN PACIFIC.**—A. R. Creelman, who has resigned his duties as general counsel, continues a director and on occasion will act as special counsel.

**CHESAPEAKE & OHIO.**—This company has sold to Kuhn, Loeb & Co. and the National City Bank, both of New York, \$3,500,000 5 per cent. notes, maturing June 1, 1914.

**CHICAGO & EASTERN ILLINOIS.**—Judge Carpenter, in the United States district court at Chicago, has given the receivers authority to issue \$4,000,000 6 per cent. receivers' certificates to pay bond interest and for repairs and improvements to rolling stock.

**CHICAGO, MILWAUKEE & ST. PAUL.**—Clark, Dodge & Co. and Potter, Choate & Prentice, both of New York, are offering the unsold portion of the \$2,999,500 Puget Sound & Willapa Harbor 5 per cent. 5-year trust certificates, guaranteed principal and interest by the Chicago, Milwaukee & St. Paul, recently sold by the St. Paul, at 98¼, yielding 5.40 per cent. on the investment.

See also Pacific & Eastern.

**DETROIT, TOLEDO & IRONTON.**—On June 28 the Northern and Southern divisions of the D. T. & I. were finally sold at auction to Otto T. Bannard and N. Buckner, both of New York, for \$1,650,000. The Ohio Southern division was recently sold. (See *Railway Age Gazette* of May 30, 1913, page 1206.)

**ERIE.**—The \$3,396,000 New York, Lake Erie and Western Docks & Improvement Company first extended mortgage 5 per cent. bonds, which are guaranteed principal and interest by the Erie, are being offered by Kissel, Kinnicutt & Co. and White, Weld & Co., both of New York, at 100½, yielding over 4.95 per cent. on the investment. The bonds are dated July 1, 1913, due 1943, and are first lien on the tidewater freight terminals of the Erie in New York harbor.

**INTERNATIONAL & GREAT NORTHERN.**—This company has asked the Texas railroad commission for permission to issue \$680,000 bonds to pay for additions and betterments. The intangible assets board of Texas has completed its valuation and it is understood that the International & Great Northern valuation has been made such as to permit this bond issue by an amended report of the commission's engineer. The total increase in the intangible assets of railroads in Texas is placed at \$5,702,248.

**MISSOURI, KANSAS & TEXAS.**—The intangible assets board of the state of Texas has placed the intangible assets of the M. K. & T. of Texas at \$20,751,450. This places the M. K. & T. second in the total list of roads having the greatest intangible values in the state, and the M. K. & T. increase over the previous year was the greatest shown by any road in the state.

**MOBILE & OHIO.**—This company has called for payment on August 1 the remaining St. Louis & Cairo 4 per cent. collateral bonds which have not been exchanged for St. Louis division 5 per cent. bonds. There were originally \$2,500,000 of these bonds outstanding.

**NASHVILLE, CHATTANOOGA & ST. LOUIS.**—On July 1 the company paid the \$6,300,000 7 per cent. first mortgage bonds which matured on that date.

**NATIONAL RAILWAYS OF MEXICO.**—In regard to rumors that the National Railways of Mexico had been put into the hands of receivers, President Huerta, of Mexico, telegraphed to Ladenburg, Thalmann & Co., New York, on June 27 that "Mr. Brown is now and will continue in the presidency of the National Railways of Mexico."

**OAKLAND, ANTIOCH & EASTERN.**—This company has asked the California railroad commission for permission to issue \$1,000,000 additional first mortgage 5 per cent. bonds to complete

the road to Sacramento. If this permission is granted it will make the total bonds outstanding \$4,000,000.

**PACIFIC & EASTERN.**—*The Commercial & Financial Chronicle* says: "Within a short time there have been in existence two Pacific & Eastern Railway Companies, one running from Medford, Ore., toward the east, the other located in Washington and running from Willapa Harbor east. It was the last mentioned company which recently had its name changed to Puget Sound & Willapa Harbor Railway Company and then passed into the control of the Chicago, Milwaukee & St. Paul. The Oregon company is still controlled by the Spokane, Portland & Seattle."

**ST. LOUIS & SAN FRANCISCO.**—On Friday of last week the receivers were given permission by the United States district court at St. Paul to pay the interest due July 1 on the outstanding \$68,557,000 refunding 4 per cent. bonds, the \$5,803,000 general mortgage 6 per cent. bonds, the \$3,681,000 general mortgage 5 per cent. bonds, the \$1,558,000 consolidated mortgage 4 per cent. bonds, the \$2,923,000 Fort Worth & Rio Grande 4 per cent. bonds, and on equipment trust certificates and principal of trust equipment certificates falling due on that date. Payment is to be made from current funds on hand and from what sum the company finds it necessary to borrow.

**ST. LOUIS SOUTHWESTERN.**—On July 1 the Stephenville North & South Texas, which runs from Gatesville to Stephenville, Tex., 75 miles, and from Hamilton to Comanche, Tex., 32 miles, was taken over by the St. Louis Southwestern and will hereafter be operated as part of the Waco division.

**SOUTHERN PACIFIC.**—See the decree of the circuit court in the dissolution suit elsewhere in this issue.

**SPOKANE, PORTLAND & SEATTLE.**—See Pacific & Eastern.

**STEPHENVILLE NORTH & SOUTH TEXAS.**—See St. Louis Southwestern.

**UNION PACIFIC.**—The plan, which includes the exchange of \$38,292,000 Southern Pacific stock for \$42,547,200 Baltimore & Ohio stock owned by the Pennsylvania, and for the disposal of the remainder by the Union Pacific, has been approved by the attorney general of the United States. See decree elsewhere.

**DINING CARS FOR INDIA.**—Two additional dining cars have been sanctioned for the North-Western State Railway of India during 1913-14.

**PROPOSED LINE FOR ARGENTINA.**—T. P. Conde & Co. have renewed their petition to the Argentine congress for permission to build and operate a railway from Gualaguaychu to the port of Corrientes.

**ARGENTINE RAILWAY CONCESSIONS ASKED.**—T. Lacroze has applied to the Argentine congress for leave to construct a line from Pereyra and Pinero stations on the Central of Buenos Aires Railway to Los Toldos, passing through Chivilcoy; a line from a point on the former to Lujan with electric traction between Buenos Aires and Lujan; and permission to double track the lines between General Sarmiento and Zarate, and from Enpalme to Giles.

**OIL FUEL IN INDIA.**—Some further particulars are now to hand of the important trial of oil-burning locomotives which is about to be carried out on the North-Western State Railway of India. There will be a six months' preliminary trial for the purpose of testing different types of burners, followed by a 12 months' trial to determine the relative values of oil and coal. Six heavy passenger engines are to be equipped with oil-burning apparatus for the latter trial and work against six coal-burning engines. Three engines of each kind will work on the mail trains and three of each type on the passenger trains between Karachi and Padidan. This is not, of course, the first time oil has been tried in India, there having been tests in 1882, 1889, 1902 and 1903, the results of which were very inconclusive. The price at which the first contract for between 6,000 and 7,000 tons of oil has been placed makes it unlikely that much saving will be shown. The contractors for the oil are to settle the system to be adopted, and are to provide an oil burning expert to coach the railway staff in order that there may be no complaints.

# Railway Age Gazette

PUBLISHED EVERY FRIDAY AND DAILY EIGHT TIMES IN JUNE, BY THE SIMMONS-BOARDMAN PUBLISHING COMPANY, WOOLWORTH BUILDING, NEW YORK.

CHICAGO: Transportation Bldg. CLEVELAND: Citizens' Bldg.  
LONDON: Queen Anne's Chambers, Westminster.

E. A. SIMMONS, *President.*  
L. B. SHERMAN, *Vice-President.* HENRY LEE, *Sec'y & Treas.*  
The address of the company is the address of the officers.

### EDITORS.

ROY V. WRIGHT, *Managing Editor.*  
W. E. HOOPER  
B. B. ADAMS  
E. T. HOWSON  
SAMUEL O. DUNN, *Editor.*  
H. H. SIMMONS  
H. F. LANE  
E. A. AVERILL  
R. E. TRAYER  
A. C. LOUDON  
E. S. FAUST  
F. W. KNABER  
A. D. CLOUD  
GEORGE L. FOWLER

Subscriptions, including 52 regular weekly issues and special daily editions published from time to time in New York, or in places other than New York, payable in advance and postage free:

United States and Mexico.....	\$5.00
Canada .....	6.00
Foreign Countries (excepting daily editions).....	8.00
Single Copies .....	15 cents each

Engineering and Maintenance of Way Edition and four Maintenance of Way Convention Daily issues, North America, \$1.00; foreign, \$2.00.

Entered at the Post Office at New York, N. Y., as mail matter of the second class.

WE GUARANTEE, that of this issue 8,150 copies were printed; that of those 8,150 copies, 6,700 were mailed to regular paid subscribers and \$45 were provided for counter and news companies' sales; that the total copies printed this year to date were 241,808—an average of 8,614 copies a week.

VOLUME 55. JULY 11, 1913. NUMBER 2.

## CONTENTS

EDITORIAL:	
Editorial Notes .....	39
Australian Railways Agree on Standard Gage.....	40
The Reasons for and the Advantages of the New York Central-Lake Shore Consolidation .....	41
Repair Cars Now .....	43
New Books .....	44
LETTERS TO THE EDITOR:	
The Roundhouse Foreman and the Road Foreman.....	44
MISCELLANEOUS:	
*Reconstruction of Kaw River Bridge; by C. E. Smith.....	45
The College Man and the Railroads; by Ivy L. Lee.....	49
*B. L. Winchell .....	51
Georgia Governor Denounces Labor Unions.....	52
System and Organization in Station Work.....	52
*Tests of Alcohol Heater Car.....	53
A City that Appreciates a Railroad.....	54
*The Minimum Efficient Gradient; by Paul M. La Bach.....	55
*Box Car for Grain and Coal Traffic.....	57
Railroad Cost and Efficiency.....	58
Transportation and Car Accounting Officers.....	60
Armour Favors Rate Advances.....	60
Proposed New Railroad Law in Maine.....	61
*Turntable Tractor .....	62
Foreign Railway Notes.....	44, 51, 53, 56, 58, 61, 63
GENERAL NEWS SECTION.....	64

\*Illustrated.

A RECENT despatch from Montreal to the *Wall Street Journal* calls attention to the fact that the Canadian Pacific, after July 1, will have practically no funded debt, since it called for payment on that date \$35,000,000 first mortgage 5 per cent. bonds. The entire capital, with certain negligible exceptions, will consist of 4 per cent. debenture stock, 4 per cent. preference stock and common stock. Sir Thomas Shaughnessy is quoted as commenting on this fact as follows: "The Canadian Pacific is unique among railroads in that no foreclosure is possible." It is true that the Canadian Pacific is unique among railroads, both on the strength of its credit, its great earning power, its enormous assets and its absence of funded debt; but that it is not subject to foreclosure sale we doubt. It will be recalled that in the last reorganization, previous to the Morgan

reorganization in 1909, the Chicago Great Western was made "foreclosure proof," in that it had no funded debt. Receivership proceedings, however, do not necessarily need to be brought against a railroad company by a bondholder. A railroad company has creditors beside its bondholders. In the case of the Chicago Great Western, the receivership proceedings were brought by general creditors, and it is well to bear this fact in mind. In this connection it is interesting to note that the new Massachusetts railroad law, an abstract of which was published in these columns last week, recognizes, apparently, that the relation of the amounts of stock to the amounts of bonds outstanding is one that must be governed largely by market conditions for railroad securities. At least the new law provides that twice as great an amount of bonds may be issued as there is outstanding stock if the company finds it expedient to do so. The former Massachusetts railroad law provided that no greater amount of bonds could be issued than there was outstanding par value of stock.

THERE are some obvious fallacies and loose expressions in the discussion by Student, published elsewhere in this issue, on the old question of allocating expenses to passenger and freight service. On the other hand, this article takes a quite novel point of view and its shortcomings may well be overlooked for the sake of new light on an old subject. The author, accepting implicitly that value of service and not cost of service determines rates, argues that since a railroad is in business to earn money, its own expenses should be divided on a value of service basis rather than a cost of service basis.

THE scathing arraignment of labor union methods and policies by retiring Governor Brown of Georgia in his farewell message to the state legislature, which is published elsewhere in this issue, is of much interest to those who have observed the development of the methods which he attacks. The justice of his statements regarding the powers and ruthless aggressiveness of the "labor trust" cannot fail to appeal to many who have observed the activities and almost unvarying success of the labor lobby in promoting legislation for its selfish interests. This legislation usually is not only of no benefit to the public at large, but often directly opposed to its welfare. The justice of Mr. Brown's comments will also appeal to those who have noted how organized labor often has succeeded in forcing up its own wages at the expense of the unorganized workers and the public by the expedient of threatening to tie up commerce and industry unless its demands are granted. Additional significance attaches to these remarks because of their source. Mr. Brown is a politician who has heretofore succeeded by a policy of direct appeal to the masses on popular issues. It may be recalled that one of the principal features of his victorious campaign for the governorship against Hoke Smith was opposition to the policy of freight rate reductions which had been carried on by the Georgia railway commission while Mr. Brown was himself a member of that body. His fight was made on the proposition that the rate cuts had been absorbed by the shippers, thus preventing any direct benefit to the public in the form of reduced prices, and that they had indirectly injured the public by hindering railway development. During a period when politicians all over the country were climbing into office by anti-railway agitation Mr. Brown secured election by boldly taking an exactly contrary stand. There was then beginning and has since occurred a marked change in the attitude of the public on the subject of railway rates. Is Mr. Brown's present outspoken attack on labor unions another example of his keenness in sensing the beginning of a change in public sentiment—this time a change in sentiment regarding labor union tactics?

IN appointing a locomotive engineer and a summer resort proprietor to membership on the upstate public service commission, Governor Sulzer of New York degrades that commission to the low estate of a political body, like its predecessor, the

old railroad commission. The hotel keeper, Mr. Leffingwell, who also has other business interests, is appointed to please the democratic politicians, and the engineer, Mr. Chase, to please the labor unions. One of these men is to take the place of Chairman George W. Stevens, whose broad statesmanship, wide knowledge and intelligent devotion to the public interest have been praised on all sides. It is not too much to say that Stevens, and the other strong men appointed by Governor Hughes, six years ago, made that commission in many respects a model, setting up new standards which have been recognized throughout the Union. Governor Dix, in some of his appointments, and now Governor Sulzer, have done what they could to reverse Governor Hughes' policy, which was to get the most competent men to be found. The fallacy that a locomotive engineer or a conductor knows as much about railroad regulation as a chief engineer or a general manager is one that seems to be specially seductive with governors and presidents, as numerous appointments at Albany and other capitals, including Washington, have shown. It may be assumed that Mr. Chase is a good engineman and a thoroughly upright citizen—as good in these respects as could be found; free from prejudice in favor of labor unions and their vicious full-crew-law notions, and devoted with a single purpose to the public interest. All this may be granted, and yet the appointment condemned, for a most essential qualification for the commissionership is experience and knowledge in the broad field of public regulation, and acquaintance with railroad operations in all departments. It is to be expected that a man who has been running a locomotive for 20 years will have many of these things to learn; and they are not quickly acquired.

JUST eight years ago the American Railway Master Mechanics' Association was awakened by George M. Basford to the necessity of giving more attention to the training of apprentices and of placing apprenticeship on a new and modern basis. It is doubtful if at that time there were more than half a dozen apprentice instructors on the railroads in this country, and, without doubt, none of the school room instruction was given during working hours. Today there are about two hundred apprentice instructors on the railroads of this country, approximately one-half of them giving practical instruction in the shops, and the other half giving technical instruction in the class room and closely co-operating with the work of the shop. Most of the class room instruction is given during working hours. This result, accomplished within a space of eight years, is indeed gratifying, but is not nearly so extensive as it should be. The problem of recruiting the ranks of railroad service is a most serious one, and while those roads which have done such splendid work are to be congratulated, it is unfortunate that so few have awakened to their responsibilities in this matter. The industrial supremacy of this country promises to be seriously handicapped because of the lack of skilled workmen, and the railways must suffer if they fail to do their part in developing such workmen. Those roads which have adopted modern apprenticeship methods must guard more carefully against one thing; the object of these methods should be to develop skilled workmen and not to provide leaders. This is most forcibly emphasized in the address which was presented before the Santa Fe apprentice instructors' conference by Mr. Basford, and which was published in last week's issue. Entirely too much attention is being given on some roads to teaching the apprentices mechanical drawing. If carried too far this is liable to make them dissatisfied with their work in the shop and to cause them to leave the shop for the drafting room. We have too many poor draftsmen now, and the young men should be discouraged from entering this work until they have had a very complete practical training, together with the necessary technical instruction. Only enough drawing should be taught in the apprentice class room to enable the boys to make proper use of the blue prints which they must follow in the shop and to make rough sketches from which to work. If any of them have serious leanings toward entering the engineering profession, they should make the necessary arrange-

ments to become more proficient in making mechanical drawings outside of the apprentice class room.

FOR a shining example of pure wantonness on the part of the labor leaders and their friends, the weak-kneed legislators, the action of this year's Massachusetts legislature, in regulating the working hours of street and elevated railway employees, should easily take first place. The governor of that state has not been particularly noted for broadminded statesmanship, but he vetoed this bill in a message setting forth some very salutary truths. It became a law, however, by a large majority, in spite of the veto. The employees referred to, including gatemen, must not be required to work more than nine hours a day, and this work time must come within a period of eleven consecutive hours; but nothing in the law shall prevent an employee, if he so desires, from working longer hours. The penalty for each offense is from \$100 to \$500. In other words, the company, if it requires a man to work for 10 hours a day, is a criminal, while the employee himself may work any number of hours without molestation. A law limiting the working period to nine hours, the work to be performed within 12 hours, was already on the books. It went into effect January 1, 1913; and eight days thereafter the labor leaders put in their petition for the change which has now been made; and this notwithstanding that there was a tacit understanding among both employers and employees, that the former law, which had been passed in April, 1912, should be left in effect a sufficient time to allow satisfactory details to be worked out. The justification for this kind of legislation rests on the principle that the state must conserve the health and general welfare of its citizens; but no such argument can be brought in behalf of this law, for the employee himself may flout it at will. Governor Foss says that "those who advise the working men of Massachusetts in respect to these repeated demands, are rapidly defeating their own purposes, and injuring the true interests of labor in Massachusetts by forcing their always increasing requirements faster than economic conditions justify. Making new demands, and with so little reason, upsets the schedules of all the corporations concerned, puts them to added expense, and serves to discourage the investment of capital in these corporations."

#### AUSTRALIAN RAILWAYS AGREE ON STANDARD GAGE.

SOME of the early experiences of the railways in the United States in their efforts to obtain a uniformity of gage are recalled by a similar agitation through which the government-owned railways of Australia have recently been passing. The engineers-in-chief of all the Australian main line state railways have finally decided unanimously for the adoption of the standard 4 ft. 8½ in. gage throughout the continent. Apparently it is easier for privately owned railways to get together in an agreement on a subject of such vital importance than for railways owned by governments. Railways were built in Australia almost as early as in this country, but a standard gage was adopted in the United States as long ago as 1886, while in Australia the gage question has been a subject of controversy since 1846, without an agreement having been reached until this year.

The necessity for uniformity in Australia has long been recognized, but there has been great difficulty in securing an agreement, and particularly in deciding between the merits of the 4 ft. 8½ in. gage used in New South Wales, and the 5 ft. 3 in. gage used in Victoria and a part of South Australia. After deliberation extending over several months the 4 ft. 8½ in. gage was adopted as standard, the total cost of the change, including alterations to rolling stock, being estimated at \$180,245,400. This compares with an estimated cost of \$250,550,000 for the 5 ft. 3 in. gage. According to the estimates the change will cost \$61,000,000 for the railways of Queensland; \$50,000,000 for the railways of West Australia, \$29,195,000 for South Australia; \$29,667,450 for Victoria; \$6,212,850 for Commonwealth territory, and \$472,000 for New South Wales. As a preliminary

step, however, it is suggested that \$57,886,700 should be first spent on securing complete uniformity for the through lines from Fremantle to Brisbane, including the Trans-Australian Railway. This will involve an outlay of \$29,667,450 for Victoria; \$13,434,500 for West Australia; \$10,834,600 for South Australia; \$4,365,000 for Queensland and New South Wales.

The engineers strongly urge that the work of conversion be begun at once on the ground that the cost will increase if the matter is further delayed, on account of the large mileage of railway now proposed to be built. It is said to be possible that the financing will be undertaken by the Commonwealth as the plan is for the benefit of the whole continent, because, although the lack of agreement among the states is the reason for the necessity of such a heavy expense now, the burden would be severe on some of the states while New South Wales, the richest of them all, would have little to pay because its lines have been built to the standard gage.

The present mileage of different gages in the various states are shown in the following table:

State or Line.	2 ft. 6 in. Miles.	3 ft. 6 in. Miles.	4 ft. 8½ in. Miles.	5 ft. 3 in. Miles.
New South Wales.....	...	...	3,760	...
Victoria.....	122	...	...	3,401
Queensland.....	...	4,287	...	...
South Australia.....	...	835	...	622
Western Australia.....	...	2,375	...	...
Northern Territory.....	...	145	...	...
Port Augusta-Oodnadatta.....	...	478	...	...
Totals.....	122	8,120	3,760	4,023

The varying gages that have prevailed on the railways of the different Australian states since their construction have naturally had a vital effect on the character of the business of the roads, and as a result of the impediment to the interchange of traffic the railway system of each state has served mainly local purposes instead of forming part of a network promoting the welfare of Australia as a whole. Because of the difference of gage it has been practically impossible to use the rolling stock of one state on the railways of another. This has necessitated the transfer of passengers and the reloading of freight at the borders, and prevented the full development of the use of the rolling stock, since under a system of interchange there would not be the same necessity for each state to provide fully for times of abnormal traffic. It has sometimes happened that cars have been idle in one state, yet could not be used to relieve a shortage in another. The necessity for transfer has naturally added to the expense of transportation, and charges have been made to cover the cost of transfer of freight and added to the ordinary rates. The break of gage has also caused delays and increased congestion on the single track lines of the state railways, because at times when the interstate traffic was mainly in one direction a train of full cars taken to the border often had to return empty, while a train often had to be run empty to the border on the other side in order to receive the freight brought on the first train, in addition to the congestion caused at the transfer point by the reloading itself.

In connection with the projected transcontinental line from Kalgoorlie to Port Augusta, which would have made possible a total journey of 4,000 miles, it was recently stated that passengers would have to change cars at least five times, owing to the difference in gage, and all baggage, mail and merchandise would have to undergo a similar transfer.

As long ago as 1846, Mr. Gladstone, then Colonial Secretary, recommended that the 4 ft. 8½ in. gage, the standard in Great Britain, should be adopted throughout the continent. In 1850, however, the engineer of the Sydney Railroad and Tramway Company strongly advocated the adoption of the 5 ft. 3 in. gage, and in 1852 an act was passed making the wider gage compulsory on all railways constructed in New South Wales. The company, having changed its engineer, changed its views as to the gage, and in the following year succeeded in having the law changed to provide for the narrower gage. This step was taken without the concurrence of the other states concerned, and as in Victoria the private companies had already placed large orders

for rolling stock to fit the 5 ft. 3 in. gage, it was decided to adhere to 5 ft. 3 in. as the standard gage for Victoria, while the Sydney Railroad and Tramway Company proceeded with the construction of its lines on the 4 ft. 8½ in. gage. These two gages have since been adhered to as the standards of the respective states. Queensland later adopted a 3 ft. 6 in. gage as best suited to its own conditions. Other states followed the practice of Victoria or the Sydney company, while in recent years light railways have been constructed in Victoria to a gage of 2 ft. 6 in. As long as the railways in the different states were required to serve purely local purposes only, the differences of gage were a matter of slight concern, but long after interchange traffic had developed differences of opinion as to the best gage, and the question of who should pay the expense of the alteration deferred any action in the matter.

Prior to the year 1886 the greatest diversity existed in the gages of the American railways. They included gages of 6 ft., 5 ft. 6 in., 5 ft., 4 ft. 10 in., 4 ft. 9 in., 4 ft. 8½ in., and some others. The expense and inconvenience of transshipment became a matter of grave concern and many plans were experimented with in the way of transferring car bodies to trucks of different gages. Even this had such serious disadvantages, however, that a conference of presidents held in the summer of 1885 came to the conclusion that the only effective solution was to establish a uniform gage, and it was decided to make the change in the following year. A conference of general managers in February, 1886, decided on 4 ft. 9 in., but that railways built to the 4 ft. 8½ in. gage should make no change, and the latter has since superseded the slightly wider gage agreed upon.

#### THE REASONS FOR AND THE ADVANTAGES OF THE NEW YORK CENTRAL-LAKE SHORE CONSOLIDATION.

IT might be expected that the reasons for the proposed consolidation of the New York Central & Hudson River and the Lake Shore & Michigan Southern would be found either in advantages to be gained from an operating standpoint or in the immediate provision of new capital. An analysis, however, of the consolidation plan indicates that while the advantages are probably financial rather than operating, it is not a plan for immediately raising new capital, but rather a farsighted attempt to provide for future comprehensive and inexpensive financing.

The New York Central & Hudson River itself has outstanding two important large issues of long term bonds. These are the \$94,000,000 refunding mortgage (now first) 3½ per cent. bonds maturing 1997, and about \$57,000,000 4 per cent. debenture bonds.

The mortgage securing the first 3½'s authorizes a total issue of only \$100,000,000; the mortgage covering by a first lien 801.98 miles of road, chiefly the main line between New York and Buffalo. The mortgage also covers the leasehold rights of the New York Central in practically all the leased and controlled lines east of Buffalo. The debenture 4's are an obligation of the road subject to the first 3½'s, but with the provision that they shall be included ratably in any subsequent mortgage placed on the property.

In addition to these two major issues of bonds, the New York Central & Hudson River has outstanding \$90,578,400 collateral trust guaranteed 3½ per cent. certificates, which are a direct and first lien, at the rate of \$200 bonds to \$100 stock, on the majority outstanding Lake Shore & Michigan Southern stock; and the New York Central & Hudson River also has outstanding \$19,336,000 collateral trust guaranteed 3½ per cent. certificates secured by direct and first lien, at the rate of \$115 bonds to \$100 stock, on the majority outstanding Michigan Central stock. The indentures securing the Lake Shore and the Michigan Central collateral 3½'s are drawn in such a way as to protect the bondholders even, it would seem, at the expense of the railroad company; and by "expense" is meant that the agreement is so ironclad as to hamper the raising of new money at the

cheapest possible rate. These indentures, it is believed, are a liability of the N. Y. C. senior to the indenture securing the New York Central & Hudson River debenture 4's themselves.

The New York Central-Lake Shore collateral indenture provides that no future mortgage can be placed on the New York Central property without extending the lien of such mortgage to include these collateral bonds and making the lien of the collateral bonds prior and superior to the lien in favor of any other bonds or debt secured by the mortgage, excepting that \$22,000,000 bonds might be issued which would be secured equally with the Lake Shore collateral bonds. The obvious intention of the \$22,000,000 authorization was to include the New York Central-Michigan Central 3½'s as an equal lien with the Lake Shore collateral 3½'s on the property of the New York Central. The New York Central-Lake Shore collateral indenture also provides that with the consent of 75 per cent. of the holders of that issue, the Lake Shore & Michigan Southern might be merged with the New York Central, but in that event the collateral trust 3½'s should be immediately secured by a lien on the property of the Lake Shore & Michigan Southern, this lien to be as full and complete as that upon its shares of capital stock.

The New York Central & Hudson River refunding 3½'s are, of course, legal investments for savings banks in New York.

The New York savings bank law provides that no bonds issued under refunding mortgages can be available as an investment for savings banks unless the mortgage in question covers mileage at least 25 per cent. greater than that covered by any prior mortgage. While it is true that the 3½'s are now a direct lien on only about 800 miles of the system east of Buffalo, the New York Central has recently merged with itself companies owning mileage aggregating some 937 miles additional; these properties having been formerly controlled through leasehold. The lien of the New York Central refunding mortgage 3½'s will automatically attach to this newly acquired property, and a meeting of the New York Central stockholders had already been called to take the necessary legal steps. It, therefore, seems plain that a new refunding mortgage could be created covering only the lines east of Buffalo which would meet the requirements of the New York savings bank law, as the mileage covered would not be 25 per cent. greater than that already subject to the refunding 3½'s.

The New York Central & Hudson River has outstanding about \$100,000,000 short term notes. Of course with the bond market in the condition it is at present it would be difficult to refund these notes with long term securities, even if the N. Y. C. had securities of the very highest grade to offer; but we may assume that the bond market will in the not very distant future begin to improve. It would then be of obvious advantage for the N. Y. C. to have a security which it could offer to New York savings banks.

Under the proposed consolidation plan there is to be authorized an issue of new refunding and improvement mortgage bonds, secured by a mortgage on the entire New York Central-Lake Shore system. These bonds, it is thought, will be a legal

investment for New York savings banks, because with the inclusion of the Lake Shore under the new refunding mortgage the 25 per cent. new mileage clause of the New York law will be fully met. L. Von Hoffmann & Co., New York, have had White & Kemble prepare a very interesting mortgage map showing the liens of the various bond issues under the proposed plan of consolidation. Accompanying this map is a discussion of the changes in position of the various security holders if the consolidation plan is carried out. Included in this discussion is the accompanying table showing the changes in the liens of the present bonds if the proposed plan is carried out.

Under this proposed plan no new capital will be raised in the process of the consolidation. After the consolidation, however, has been effected the New York Central will have a mortgage on the entire N. Y. C.-L. S. & M. S. system under which it is proposed to issue ultimately some \$500,000,000 bonds.

Assuming that the Von Hoffmann analysis is correct, holders of the New York Central prior liens will not be affected one way or the other by this consolidation plan, except that their bonds become a direct obligation of the parent company while retaining the same mortgage lien which they have always possessed.

Holders of the first 3½'s will apparently be put in a better position since their bonds will remain in the same relative position to the rails that they are now on 800 miles, and will be a direct lien instead of a lien on the leasehold estate of the additional 937 miles going to make up the lines east of Buffalo. Furthermore, they will derive the advantages of the additional equities provided from the sale of new refunding and improvement mortgage bonds. On the other hand, of course, there will be outstanding as soon as any of these new refunding bonds are issued more N. Y. C. bonds that are legal investments for savings banks.

The holders of New York Central debenture 4's which now are not secured by mortgage on any property will be secured by a mortgage—junior, it is true, to that of the non-exchanged Lake Shore collateral 3½'s and the Michigan Central collateral 3½'s—on nearly 1,800 miles of road.

This subordination to the Lake Shore collaterals and Michigan Central collaterals has always existed, however, as the indentures securing the two last named issues, drawn in 1898, specifically provided for the ultimate securing of the collateral bonds by a mortgage on the New York Central, and the indenture securing the New York Central debentures, of which the first outstanding issue was made in 1904, was drawn in recognition of what might be termed a prospective mortgage already on the property, in addition to the lien of the refunding 3½'s. Upon the consummation of the plan, as proposed by the New York Central, the holders of New York Central-Lake Shore collateral 3½'s may either retain the bonds which they own, secured by a lien on the New York Central jointly with the Michigan Central collaterals, subject to the first 3½'s and prior to the debentures and all other issues, and further secured by a mortgage on the Lake Shore property, subject only to the 3½'s and debentures and prior to all other issues, or, if they wish, they may exchange their 3½ per cent. bonds for 4 per cent. bonds, which will rank on the combined mileage 1 deg. lower in point of security, that is, on a parity with the New York Central debentures on the mileage east of Buffalo and junior to the unexchanged collaterals on the mileage west of Buffalo.

Holders of Lake Shore prior lien bonds will not be affected, and holders of the debenture 4's of the Lake Shore will get a junior mortgage on 826 miles, whereas they now have no mortgage security.

If the holders of Lake Shore collateral 3½'s could now exchange, even at some future time, their bonds for Lake Shore stock at 200, it is doubtful if they would consent to an exchange of their present 3½ per cent. bonds even for a 4 per cent. bond. The indenture, however, makes no provision by which these Australateral security holders can get at the Lake Shore stock. In case of default, the Lake Shore stock must be sold in its ordinary

Bond.	Mileage previously covered.	Mileage covered under proposed plan.	Rate per mile on mileage covered.
New York Central prior liens.....	Unchanged	Unchanged	\$31,850
New York Central first 3½s, 1997.....	801.98	1,739.45	54,040
New York Central unexchanged Lake Shore collaterals .....	None	2,670.25	†8,480 *
New York Central Michigan Central collaterals .....	None	1,844.35	†10,484
New York Central debenture 4s.....	None	1,844.35	†31,009
Lake Shore & Michigan Southern first 3½s, 1997 .....	Unchanged	Unchanged	60,540
Lake Shore & Michigan Southern debenture 4s .....	None	825.90	121,080
New 4s issued in exchange for Lake Shore collaterals .....	.....	2,670.25	*†25,441

\*Based on exchange of 75 per cent. of Lake Shore collaterals.

†Bonds marked thus are secured by equal liens on property now of New York Central.

†Bonds marked thus are secured by equal liens on property now of New York Central.

for the benefit of the collateral security holders, unless the holders of 75 per cent. in amount of the bonds outstanding instruct the trustee in writing to dispose of the stock in parcels. Since, then, even if the Lake Shore stock was worth intrinsically a good deal over 200 per share, there could be but few bidders for \$45,000,000 of it, the present plan, therefore, does not take away apparently any very real asset from the collateral 3½ per cent. bondholders, as it secures to them a lien upon the Lake Shore property at least equal to that which they now possess through the pledge of Lake Shore stock. It is also important to note that the issuance by the Lake Shore & Michigan Southern of additional debenture bonds, which would rank ahead of the pledged stock, is terminated by the plan under way, so that while under former conditions it might have been theoretically possible to increase the amount of bonds prior to the stock, the position of the collateral bonds is now definitely determined and cannot be changed. This same argument holds true in regard to the Lake Shore debenture 4's as the plan effectually prevents the issuance of additional bonds on a parity with them. The plan has also the obvious attraction of giving to the holders of New York Central-Lake Shore collateral 3½'s who consent to the proposed merger, and who elect to make the exchange offer a security yielding them 4 per cent. instead of 3½ per cent.

Summed up, then, the gist of the reasons which led to the adoption of the consolidation plan of the Lake Shore & Michigan Southern and the New York Central & Hudson River is as follows: The present arrangement of the New York Central's debt would not permit of a refunding bond issue covering only the lines east of Buffalo which would be legal for New York savings bank investment. The Lake Shore collateral indenture hampers the raising of new capital for that property.

In order to merge the two properties and secure the increased mileage necessary for the creation of a savings bank mortgage, the consent of 75 per cent. in amount of the Lake Shore collateral 3½'s becomes necessary, and to secure that consent the inducement of ½ per cent. additional income has been offered to the holders of the Lake Shore collateral 3½'s. By consolidation of the two properties and the exchange of Lake Shore collateral bonds for a new security, a comprehensive refunding mortgage may be created under which new capital for both properties may be raised and which, it is probable, will secure the largest authorized issue of bonds that has ever been created on an American railroad.

**REPAIR CARS NOW.**

THERE may be a car shortage again next fall, and it may be worse than the car shortage of last fall. There are, of course, a good many things which can be done which will tend to postpone or mitigate such a shortage. There is one thing, however, which should be done at once. A start should be made now to reduce the number of cars in shops. Last year the start seems to have been made a little too late, and as a result, there was a larger percentage of cars in shops in October and November, 1912, than there need have been. The figures are instructive.

The statistical bulletins of the American Railway Association show that the percentage of cars in shops increased up to and including last July. We all know that strenuous measures were then taken to put as many cars in good repair as possible. As a result the percentage was brought down to 6.36 in October, 6.22 in November, and 6.00 in December. It would have been much better if the minimum had been reached in October, as even the fractional difference between October and December meant a difference of seven or eight thousand cars in service. Should not an early start be made this year with car repair work, with the idea of coming down to the minimum in October?

This raises the question, what standard should be aimed at? There is a general feeling that 5 per cent. of the cars in shops is without right, and this would seem to be confirmed by the American

Railway Association figures, which show 5.02 as the lowest percentage on record. This was achieved in the first three months of the year 1907, immediately after the great car short-

PERCENTAGE OF FREIGHT CARS IN SHOPS.		PERCENTAGE OF FREIGHT CARS IN SHOPS.	
American Railway Association Statistical Bulletins.		American Railway Association Car Location Bulletins.	
1912.		1912.	
April .....	6.36	Nov. 30 .....	6.04
May .....	7.39	Dec. 14 .....	5.68
June .....	7.79	31 .....	6.12
July .....	7.92		
August .....	7.21	1913.	
September .....	6.84	Jan. 15 .....	6.15
October .....	6.36	Feb. 1 .....	5.77
November .....	6.22	15 .....	5.90
December .....	6.00	Mar. 1 .....	6.04
		15 .....	6.05
1913.		Apr. 1 .....	6.28
January .....	6.49	15 .....	6.24
February .....	6.17	May 1 .....	6.67
		15 .....	6.93

age of 1906. If this figure can be reached this fall this alone will make available perhaps 30,000 more freight cars than were available last year. Below is a comparison of the percentages of cars in shops for the first three months of 1907 and for October, 1912, divided up by groups:

PERCENTAGE OF FREIGHT CARS IN SHOPS.		
Groups—	First three months of 1907.	October, 1912.
1. New England .....	2.18	7.37
2. N. Y.; N. J.; Del.; Md.; Eastern Pa. ....	5.54	5.19+
3. Ohio; Ind.; Mich.; Western Pa. ....	5.40	8.19
4. Va.; W. Va.; N. C.; S. C. ....	7.05	6.43+
5. Ky.; Tenn.; Ga.; Ala.; Miss. ....	3.66	8.15
6. Ia.; Ill.; Wis.; Minn.; Dakotas. ....	4.12	6.66
7. Mont.; Wyo.; Neb.; Dakotas. ....	5.24	6.13
8. Kans.; Colo.; Okla.; Mo.; Ark. ....	6.16	7.94
9. Texas; Louisiana; New Mexico. ....	4.20	4.89
10. Ore.; Idaho; Nev.; Cal.; Arizona. ....	4.70	4.73
11. Canadian Lines .....	5.11	5.54
Mexico .....	3.05	....
Average .....	5.02	6.36

There are two satisfactory points about this comparison. One is that an improvement was made in the Trunk Line group, which owns nearly one-third of the cars. The other is that the South Atlantic group, which made the worst showing in 1907, did much better in 1912. In all the other groups there were more freight cars in shops last October when they were badly needed, than there were at the same time five years ago.

It is by no means unusual to have the percentage of cars in shops smaller in December and November than in October. This was the case in 1909 and 1910. The car location bulletins (which have been issued only this year) give percentages a little lower than those in the statistical bulletins; but they would seem to show that, while in April the roads did about the same as last year, they did a little better in May. If a start is made promptly in July, it ought to be easy to get a month or two ahead of last year's figures; and if the repair work in the shops is thoroughly done, it will so permanently improve the cars that there will be no wasteful expense, even if a car shortage does not come.

A reduction of the number of cars in shops will give the statistician a gratifying little by-product. The figure showing the average mileage per car per day which reached its maximum, 26, last October and November is based on all cars in the country, including those in shops. If the number of cars in shops is reduced and the movement maintained on those out of shops, the average miles per car per day will show a gratifying improvement. There are many other opportunities, of course, for improving this figure by a reduction of delays, especially in yards, but this is another story, and can be attended to later. The thing which should be done today is to use every effort to put the freight car equipment in good condition.



## NEW BOOKS.

*Railway Signal Engineering.* By Leonard P. Lewis, of the Caledonian Railway (Scotland). Cloth, 376 pages, 5¼ in. x 8¼ in.; 250 drawings. Published by D. Van Nostrand Company, 25 Park Place, New York. Price, \$3.50.

Mr. Lewis is a lecturer at the Glasgow and West of Scotland Technical College, and his book is one of a series entitled "The Glasgow Text Books of Civil Engineering." It has the merits and demerits of a lecture-manual; though the only reason why we mention demerits is the absence of local references. Of all the drawings that we have examined not one has any indication of place or time; and of "local color," so much appreciated by American readers, there is very little. References to new or unknown devices or methods of working are only partially satisfactory when they give no hint of how many or what railways or signal engineers have added or tried them. To say that a new device is "on the market," with no inking of any impartial person's opinion of it or whether it is worth trying, also makes filling for the pages of a book which is of doubtful quality.

But these are minor points. The book treats of the details of British signaling very fully, and the writer has the distinctive merit of the tutor; he aims constantly to answer the reader's questions, and with marked success. He does not touch power interlocking, nor is there a word about automatic block signals; but in the mechanical field the treatment is thorough and careful, and any railway man, whether interested particularly in signals or not, can find here a great mass of information about current English practice, concisely set forth. On this book the printer and the bookbinder have done an excellent job.

The first chapter gives a few very brief notes on early types of signals. The titles of the other chapters are as follows: Board of Trade rules; Classes and uses of signals; Constructional details; Point connections; Interlocking apparatus; Signal cabin arrangements; Miscellaneous apparatus; Signaling schemes; Interlocking tables (locking sheets, etc.) and Methods of working trains. Under miscellaneous apparatus there is a brief notice of track-circuit locking. "Interlocking tables" fill 40 pages, the chapter going very fully into the fundamentals of interlocking theory and practice.

*Solution of Railroad Problems by the Slide Rule.* By E. R. Cary, professor of railroad engineering and geodesy, Rensselaer Polytechnic Institute. Size, 4 in. x 6 in.; 136 pages; cloth binding; 43 illustrations and numerous tables. Published by D. Van Nostrand Co., New York. Price, \$1.

The "Solution of Railroad Problems by the Slide Rule" is the outgrowth of a series of problems which were developed by the author for classroom work. On account of the ease and rapidity with which such problems can be solved with the slide rule it is in very common use, and such a book as this should be of value to students and young graduates in pointing out the easiest methods of handling such computation. In addition to a discussion of the construction of the slide rule, the book includes chapters on simple curves, compound curves, vertical curves, turnouts, easement curves and earthwork.

*The Science of Burning Liquid Fuel.* By W. N. Best. Illustrated. Bound in cloth. 153 pages, 6 in. x 9 in. Published by the author at 11 Broadway, New York, N. Y. Price \$2.00.

The author has devoted a great deal of time to the use of fuel oil and has endeavored to make this book thoroughly practical. Analyses of oils from different localities are given and a chapter on atomization gives illustrations and descriptions of different oil burners. The systems in use for burning oil as fuel are dealt with and locomotive, stationary and marine applications are described, while considerable attention is given to ovens and furnaces. In this book there are a large number of illustrations.

## Letters to the Editor.

### THE ROUNDHOUSE FOREMAN AND THE ROAD FOREMAN.

New York, June 28, 1913.

TO THE EDITOR OF THE RAILWAY AGE GAZETTE:

I have read with interest your editorial of this week on the making of locomotive engineers, and more particularly what you say about the number of men that can be supervised by a single road foreman. The suggestion that 100 men is too large a number touches on a matter which ought to have more attention than it now receives. While your declaration points in the right direction you have left a good deal unsaid. How can a single foreman supervise 100 men, even under the most favorable circumstances? On roads where the traffic is dense and the locomotive districts are short it may be possible, but I seriously doubt it; and where the road foreman has, as is quite customary, the enginemen on two or three districts under his charge he invariably has more work than he can handle. There are times when a road foreman has to spend three or four days in succession holding investigations with the trainmaster or the superintendent; at such times, unless he has an assistant, there is no one out on the road looking after the enginemen, and in all probability another set of investigations is developing while he is engaged in cleaning up the first set.

I know of numerous cases where enginemen do not have the road foreman on the locomotive with them once in six months. Some of them do not need his visits, but more of them do. It is only by constantly watching and checking up men that bad practices will be eliminated; and even the best enginemen, if not in touch with the road foreman, at least some of them, will frequently fall back into slipshod ways. The road foreman of engines is at present too much of an investigator and corrector of matters which are history; his main duty should be the education of his men along lines which will keep them (and the company) out of trouble; and he cannot accomplish this satisfactorily when his jurisdiction covers too much territory and too many men.

The placing of young enginemen on passenger trains is something which requires great care in the handling. I have known enginemen who could handle a passenger train well the day they were passed as engineers; and others who would never, with any amount of experience, make a good job of handling anything but a switch engine. When I was first placed in charge of an engine house I was cautioned by the master mechanic against using inexperienced men on passenger runs and told that if at all in doubt as to a man's ability I should not hesitate to run a more experienced man around him. It requires courage on the part of an engine house foreman or an engine despatcher to take such a step, for it invariably results in a stormy time with the man who thinks he is wronged and possibly also involves payment of run-around mileage. However, if a foreman uses good judgment I believe he will always find his superiors back of him; and looking back on a great many cases of this kind I can think of none where the man went to the grievance committee of the brotherhood. Some of the men I had to deal with were of that kind which would never make competent passenger men. Others merely lacked experience, and after a sufficient number of trips on passenger trains, accompanied by the road foreman, if the latter informed me that they were competent to handle a passenger locomotive, I never hesitated in the future in calling them for such work in their turn.

ENGINE HOUSE.

TERMINAL FOR BAHIA BLANCA, ARGENTINA.—The Argentine Railway has purchased for \$1,000,000 a large site in Bahia Blanca for a terminal station.

# RECONSTRUCTION OF KAW RIVER BRIDGE.\*

Old Spans Were Moved Transversely and Endwise and Another Span Added. Unusual Method Used to Move Structure.

By C. E. SMITH,  
Bridge Engineer, Missouri Pacific.

The Kaw, or Kansas river, is the third largest tributary of the Missouri, entering that stream at Kansas City. The watershed of the Kaw extends westwardly about 500 miles and has a drainage area of about 60,000 sq. miles. The capacity of the channel near the mouth is about 150,000 cu. ft. per second, which is equivalent to about 0.1 in run-off per day from the watershed. In May, 1903, the normal rainfall of  $4\frac{1}{2}$  in. for the month fell in the first 21 days, followed by  $8\frac{1}{2}$  in. in the next 10 days. This great flood caused the river to overflow its banks and to fill the entire valley from bluff to bluff for 150 miles above the mouth at depths ranging up to 20 ft. For a distance of about 17,000 ft. above its mouth the river passes through the thickly settled business portion of Kansas City, Kans., containing stock yards, railroad yards and wholesale houses. In this distance the river was crossed by 14 bridges, and there were three more a short distance up stream. The channel had been narrowed by refuse dumped in the stream by the industries along the bank and the waterway had been still further reduced by rip rap placed around the bridge piers for protection against scour.

## FLOOD CONDITIONS.

The main line of the Missouri Pacific crossed the river on a double track structure about 100 ft. below a similar bridge of the Union Pacific. Each of these bridges consisted of three 180

cover the cost of these improvements. It was decided to build levees to protect the banks, to increase the width of the channel, to dredge the channel to at least 15 ft. below low water, and to limit all bridges to two river piers 300 ft. apart founded on rock. As practically all of the bridges had been rebuilt in 1903 and 1904, most of the bridge owners, including all the railroads, offered to reconstruct their bridges on new piers and abutments which would allow the use of present trusses with the understanding that they would join in the expense of widening the river at bridge crossings to provide such additional width as would be occupied by additional piers. The owners also objected to the requirement that piers be founded on rock and in the case of the U. P. and M. P., both of these matters were finally settled by the courts in favor of the owners. The reconstruction of these bridges was delayed several years by two overhead bridges at the west end of the river crossing maintained by the Kansas City Southern and the Stock Yards Company. The clearance under these bridges being approximately 21 ft., it was impossible to make the raise in the U. P. and M. P. bridges called for by the proposed reconstruction. In the spring of 1910 the river bridges were each raised  $2\frac{1}{2}$  ft., which was as far as they could go without interference with the overhead bridges.

The new Missouri Pacific bridge was designed to use the

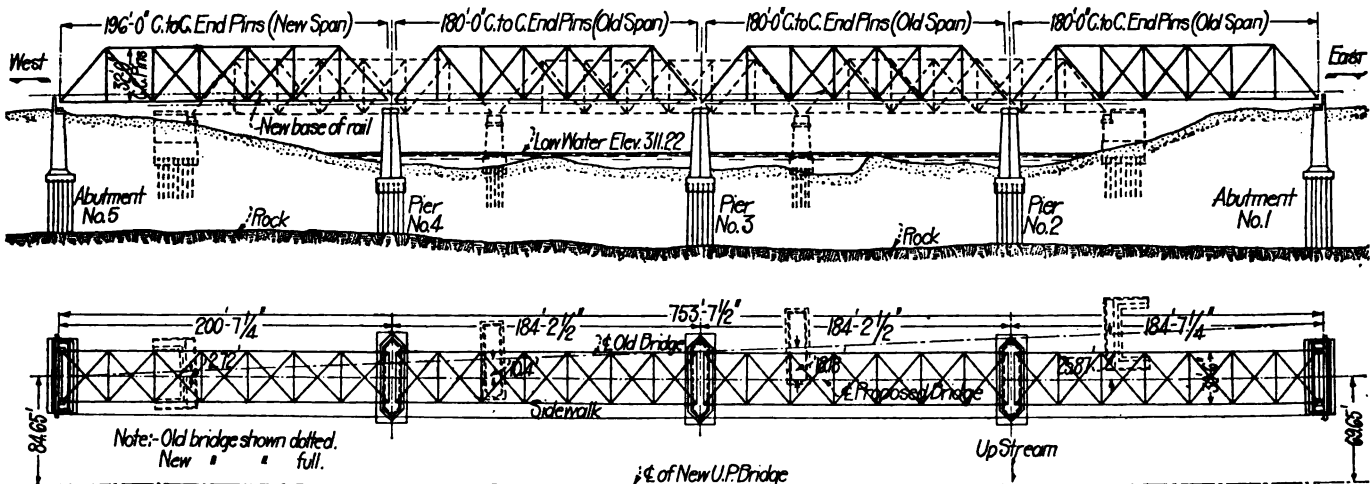

Plan and Elevation of New and Old Bridges.

ft. double track truss spans resting on masonry piers and abutments. When it was realized that the flood of May, 1903, would go over the decks of the bridges it was decided to weight them down with cars and locomotives. The drift which was caught by the Union Pacific bridge forced the spans from their supports and the trusses with their cars and the drift that had accumulated swept under the Missouri Pacific bridge. This formed almost a solid dam across the river so that the water passed over the tops of the locomotives standing on the latter bridge. In spite of this the bridge remained intact, being the only one of the 17 at this point that did not go out.

After the 1903 flood the war department appointed a board of engineers to make recommendations for the improvement of the river, and by an act of legislature the state of Kansas created the Kaw valley drainage district with power to issue bonds to

three old trusses, each 180 ft. long, which had been built for a loading of Cooper's E-50 in 1900. The additional width of the river necessitated the addition of a 196 ft. span. As 734 ft. was the adopted width of channel between the tops of levees, the total length of the bridge was made 742 ft. to compensate for the width of the third pier. A change in alinement was also necessary since a sharp reverse curve had been laid out at the east end of the bridge since its construction which would have been made worse by extending the bridge at that end on its old alinement. The west end of the bridge was fixed by conditions which prevented any large side movement so that the alinement finally chosen was 3.4 ft. up-stream at the west end and 26.3 ft. at the east end. It was decided to treat the three spans as one structure and move the entire bridge at one time. This decision was reached largely on account of the necessity of keeping the bridge in almost continuous service during the reconstruction. The contract for the foundation work was let to the Union

\*Abstract of a paper presented before the Associated Engineering Societies of St. Louis, May 7, 1913.

Bridge & Construction Company, Kansas City, Mo., on a force account and fixed fee basis, this method of payment being adopted on account of the presence in the channel under the old bridge of large quantities of old bridge iron, cars and other debris that had been deposited there in the 1903 flood, and also on account of the very heavy railroad traffic across the bridge and the congested yards at both ends.

NEW SUBSTRUCTURE WORK.

The new abutments are buried piers 26 ft. x 54 ft., and 50 ft. 6 in. high, supported on 96 piles each. The footings are 7

While the abutments were under construction timber barges were framed on the shore and were equipped with hoisting engines, derricks and dredge buckets for clearing the site of the new piers. Many methods of passing the obstructions in the river bed were considered, including the use of pneumatic caissons and of steel sheet piling. It was realized at once that steel sheet piling could not be depended on to cut its way through such a tangled mass of steel and the cost of cutting through this steel in compressed air would have been exorbitant, especially as it was known that bridge pins, car axles and other very heavy steel parts would be encountered. It was, therefore,

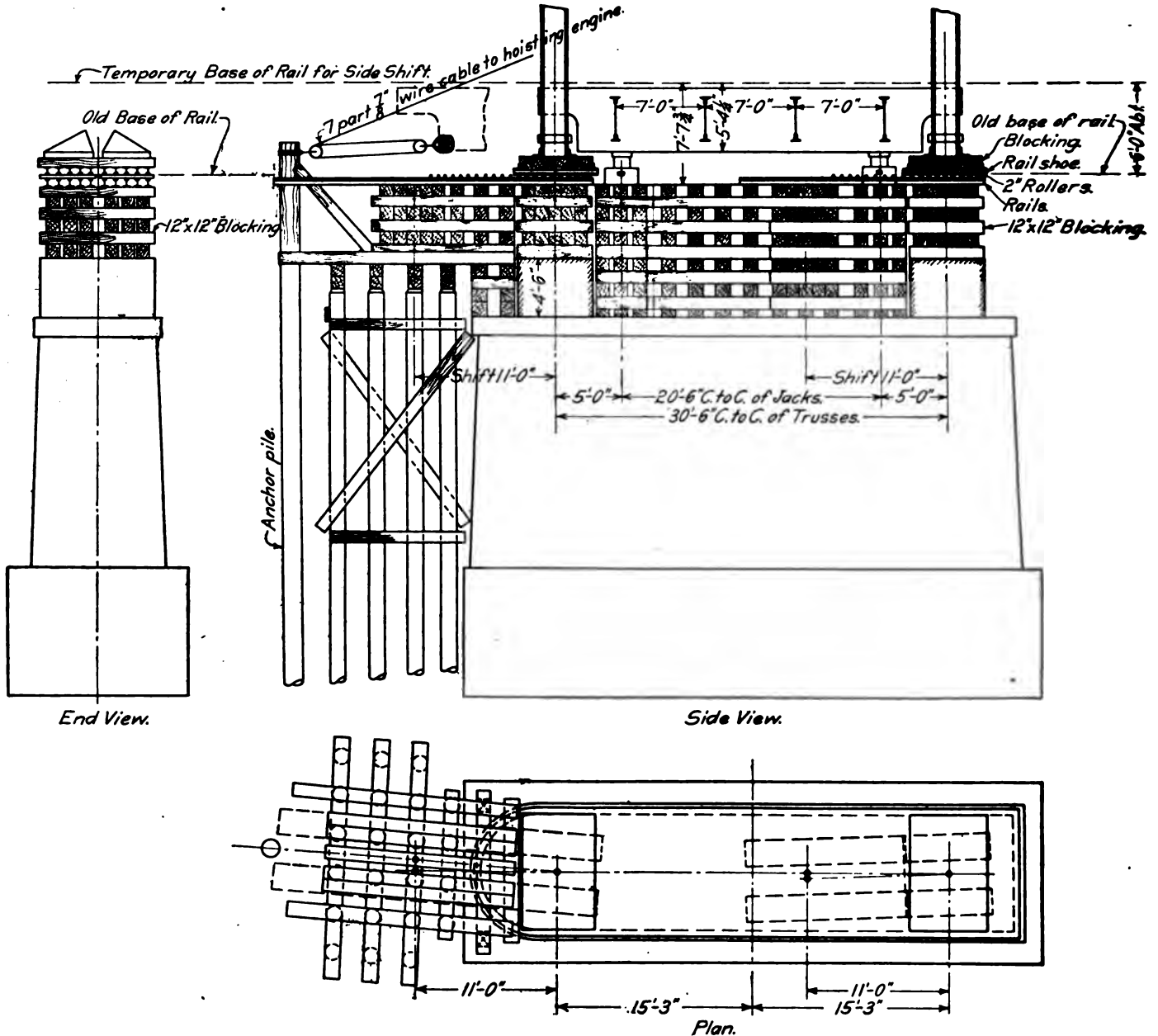

Details of Falsework and Blocking at Pier During Side Movement of Spans.

ft. deep and project 7 ft. in front of the neat work. The shaft is 9 ft. wide at the top of footing. The backwalls are 6 ft. high and are extended 9 ft. beyond each end of the pier to prevent the ballast and back fill from running around onto the bridge seat.

During the excavation for the abutments the track was carried on temporary blocking until a sufficient depth had been reached to allow the insertion of 60 ft. deck plate girder spans. Open excavation was carried down about 14 ft. below the bottoms of the girders. Below that level the excavation was made in cofferdams.

decided to remove this material over the entire river bed by dredging through the water with orange peel and clam shell dredges before placing any cofferdams. Dredging at pier two continued night and day for six weeks, at pier four for three weeks, and at pier three for six weeks. The expense of the removal of this debris made the cost of excavation for the piers unusually high. This dredging was very tedious. At times the bucket would strike steel and come up empty, again it would take hold of a mass which it could not move, again it would be caught in the obstruction and require great care to free it. As a rule the free material was dredged as deep as

possible around the old bridge iron and when the dredge failed to bring up any more material a diver was sent down to dynamite the steel until the parts were sufficiently loosened to be removed. Much of this work was done in 30 ft. of water.

The footings of the new piers are 18 ft. wide and 54 ft. long, with 108 piles under each pier. The shafts of the piers are 12 ft. 6 in. wide at the top of footings and 9 ft. wide under the bridge seat coping course. While the dredging was in progress the pier cofferdams were built on shore. In order to avoid damage to the lower edge in case the cofferdams were to strike any steel still remaining in the bed of the river they were provided with steel cutting edges. As the previous dredging had extended so deep the sinking of the cofferdams was comparatively simple. On account of the porous soil under the bed of the river the cofferdams could not be pumped out and the piles were driven through the water. After the piles were all driven in a cofferdam a sand sucker was used to remove the accumulated sand and debris down to the proper level, after which a 5 ft. sealing course of concrete was placed around the heads of the piles by

as the flood was carrying large cakes of ice which were striking the forms violently. After the flood subsided, however, it was found that no damage had been done and the concrete proved to be as good as any in the bridge. On account of the late start which was made in the season of 1911, and the time consumed in clearing the river bed, all of the concrete was placed during the winter, most of it at temperatures below freezing. The three piers were practically completed March 16, 1912.

#### TRANSVERSE MOVEMENT OF SPAN.

The contract for removing the superstructure was let to the Jobson-Gifford Company, New York, and work was begun about the middle of January. It was decided to move the old bridge in the following order: First, raise the three old spans to the full height; second, move the old spans transversely to the new alignment; third, shift the spans longitudinally to their final position, and fourth, erect the new span. As the bridge had been raised 2½ ft. in 1910, the remaining raise amounted to about 6½ ft. It was decided that one end of a span 180 ft. long could be raised ¼ the total lift higher than the other end

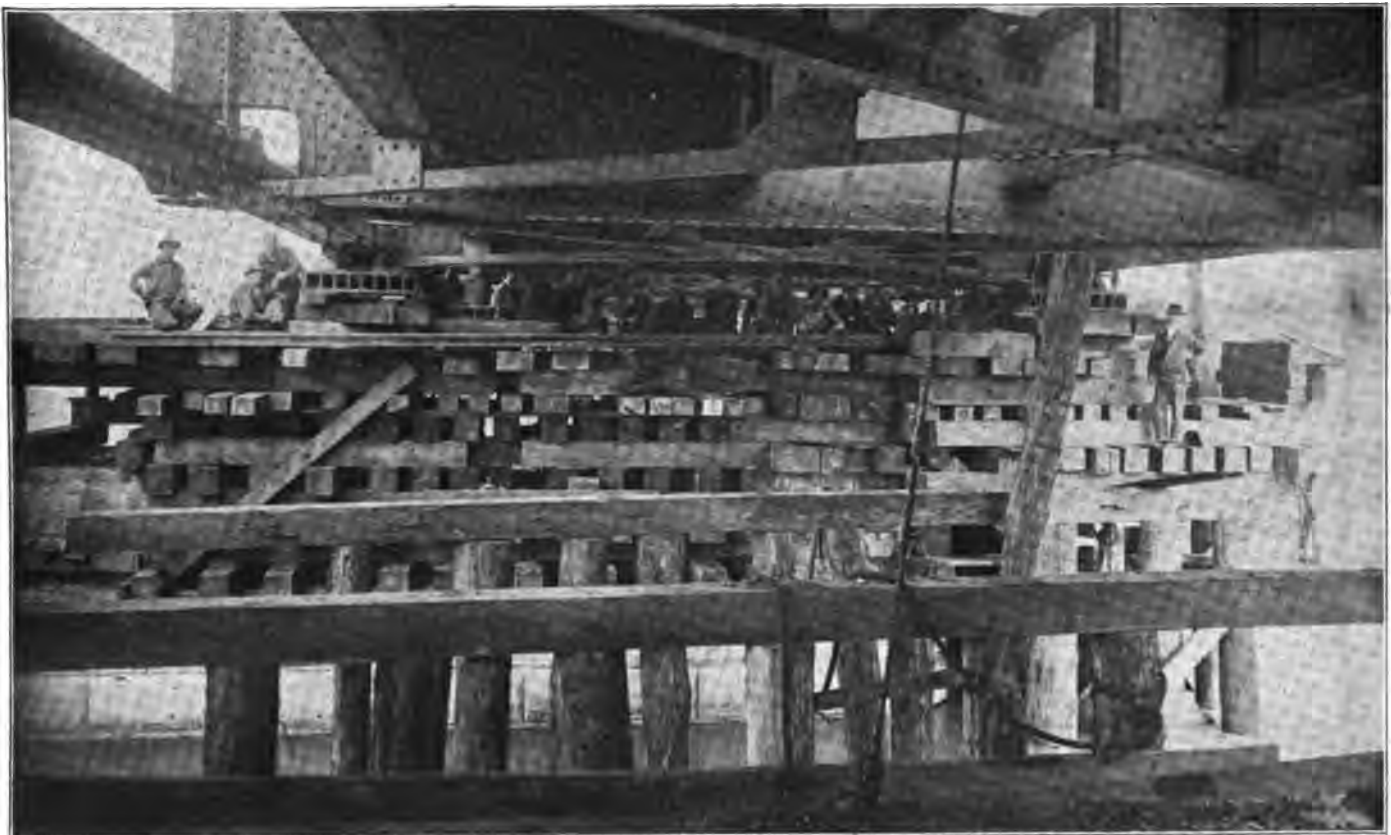

Side View of Blocking on Pier During Raising of Bridge.

means of a tremie, consisting of a 10 in. pipe surmounted by a square trough. The bottom of the tremie was placed on the bottom of the excavation and the pipe filled with a concrete of a 1:2:3 proportion mixed very wet. The tremie was slowly moved from side to side of the cofferdam working from end to end between the rows of piling until the desired thickness of 5 ft. was placed. This sealing course was allowed to set six days, after which the cofferdams were pumped dry, the piles cut off 6 in. above the surface of the concrete and the remainder of the piers placed in the dry.

In placing the middle pier a flood came very nearly overtopping the cofferdam, and to prevent this, concrete was placed continuously day and night, the forms being built at the same time. By strenuous work the level of the concrete was maintained about 1 ft. above the level of the flood until the crest was reached. The concrete was raised 20 ft. in 24 hours, and some fear was felt as to the bursting of the forms, especially

without detriment to traffic, resulting in a grade of about 1 per cent. on the span.

The work of lifting was slow, but the work of removing the overhead bridges was slower and the jacking was very nearly delayed by their presence. As the bridge was raised the load was carried on 12 in. by 12 in. blocking which served three purposes: First, to carry the truss shoes in their former location; second, to carry the jacks for raising the span, and third, to carry the load in the new location that would be assumed by the truss shoes after the transverse movement. The intermediate spaces were filled with rough timber blocking to carry the trusses while the bridge was being rolled sideways. As the bridge had to be kept continuously in service it was impossible to jack for long periods, but arrangements were made to give the contractor about 40 minutes in the forenoon and about an equal time in the afternoon. During each of these periods it was usually possible to make a lift of about 1 ft.

When the spans had been raised  $2\frac{1}{2}$  ft. in 1910 pedestals had been built up of I-beam grillages buried in concrete with their tops  $4\frac{1}{2}$  ft. above the top of the main pier. The further raise of  $6\frac{1}{2}$  ft. made the pile of timber blocking on the piers 10 to 11 ft. high for the support of the jacks and of the spans in their new positions.

Pile driving for the falsework was started before the completion of the jacking. As much of the falsework came under the old trusses and could only be driven from the bridge, it finally became necessary to take one track on the bridge out of service continuously. For the side movement at the west abutment which was only 2.7 ft. a frame bent was set on the upstream projection of the footing course and the blocking on the

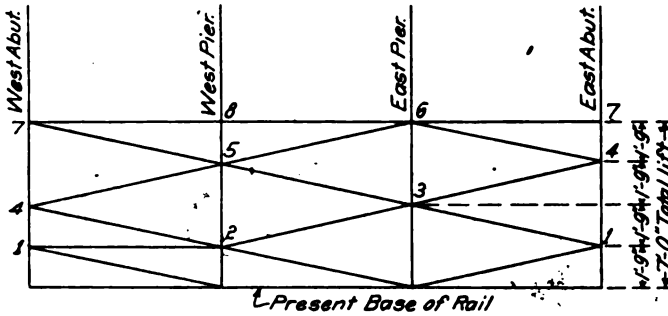

Starting at abutments, raise base of rail to position "1". Then raise over west pier to "2" and similarly in succession to "8" when entire bridge will be at desired grade

**Jacking Diagram for Raising Bridge Before Transverse Shift.**

pier was extended out over it to form a support for the trusses in their new position. At the two river piers and the east abutment, posts were set on the footing projections and pile bents were driven at 3 ft. intervals, each bent having five piles 3 ft. apart. The blocking on the piers and east abutment was extended out over these bents to form pile pier extensions for the support of the up-stream trusses after their movement.

Just before starting the transverse movement the trusses were jacked up and the blocking immediately under the shoes was replaced by two nests of rails separated by rollers. The lower nest consisted of four rails spaced 7 in. apart covering the new and old locations of the truss shoe as well as the space between them. The upper nest consisted of four rails turned upside down, slightly longer than the width of the shoes. Between the upper and lower rails were placed a number of 2 in. rollers 4 ft. long made into nests by angle irons which served as spacers for the rollers. The length of each nest was equal to the width of shoe plus  $\frac{1}{2}$  the distance through which the shoes were to move. The rollers were spaced 6 in. apart for the rolling. As it was necessary to put them in under some shoes several days in advance of the movement, the rollers directly under the shoes that carried the weight of the traffic were spaced 3 in. apart in order to avoid danger of the rails cutting into them and increasing the difficulty of rolling. After all the rollers had been placed a sudden rise in the river caused some anxiety as to the safety of the structure since the water level was considerably above the tops of the old piers and the spans could easily have been rolled off. Arrangements were made to load the bridge, but the rise was not great enough to require it.

The transverse movement of the bridge was effected by hoisting engines, the falls consisting of seven part  $\frac{7}{8}$  in. steel cables. These were anchored to a large cypress pile driven at the end of each pier. The lead lines were operated by a derrick car at each end of the bridge and by hoisting engines on flat cars over each pier. As the movement of the bridge was not the same at all of the supports it was necessary to calculate the direction of movement at each support so as to make the complete bridge move somewhat similar to the spoke of a wheel, the center of rotation being 60 ft. west of the west abutment. The angle of

inclination of the rails and rollers was so adjusted at each support that the movement of the rollers would take place along a chord to the curve through which the shoe was moved. It was feared that difficulty would be experienced in controlling this movement so that the proper amount of movement would be made over each support, but the hoisting engines controlled the bridge so well that at no time was it more than 2 or 3 in. out of line. The track was cut at 10:35 a. m., and connected up again in the new location at 1:15 p. m., an interruption to traffic of two hours and 40 min. The work of moving the span required only 50 min. of this time, and the actual rolling time was not more than 2 min.

During the raising and side movement of the bridge, falsework piles were being driven continually and practically all the piles were in place when the side movement was made. This falsework consisted of blocking on the ground at each end of the bridge landward of the old abutments and pile bents in the river. These bents were spaced 14 ft. apart and each bent was composed of eight piles driven to refusal and capped with a 12 in. x 12 in. timber. When these piles were cut off the water was within a few inches of the level of the cutoff and still rising. The caps had to be put in place in the water. As the water never fell below the caps until after the longitudinal movement was completed, it was impossible to properly brace the pile bents. The condition of the falsework in this respect was far from desirable, but the proximity of the spring flood made it necessary to go ahead with the work without the bracing.

**LONGITUDINAL MOVEMENT.**

The longitudinal movement of the bridge was made on especially built trucks after considering a number of other methods. The use of small rollers would have been very expensive on account of the large number of rollers and other apparatus that would have been required. Standard car trucks were not used as no satisfactory method could be worked out to avoid the overloading of individual trucks, the failure of any one of which would have been disastrous. The special trucks were built of heavy timber and standard car wheels, axles and journal boxes. These trucks were designed to operate on two standard gage tracks 15 ft. 6 in. center to center laid on the falsework at an



**Trucks Carrying Bridge Over Deck Girder Falsework Span.**

elevation of 11 ft. below the tracks on the bridge. Two trucks were placed under each corner of each span, making eight trucks of three pairs of wheels each supporting each 500 ton span, or a load per axle of 21 tons.

As the load on any axle under the best conditions would be high it was decided to use only axles and wheels that had been tested in service. The 72 pairs of wheels which were required were removed from 50 ton coal cars and made up into 24 trucks, the three pairs of axles being held in place by 12 x 12 in. timbers bolted to the tops of the journal boxes at each end of the axles. Other 12 in. x 12 in. pieces were laid crosswise on these timbers to distribute the load equally among the three axles. On top of these was placed the blocking for supporting

the bridge. The trucks were placed under the centers of the stringers in the end panels and the next to the end panels of the trusses, enough blocking being placed under the stringers to throw the load on the trucks. The distribution of the trucks made it practically impossible for any one truck to carry double the load for which it was designed, but it was thought that there might be an increase of 50 per cent. on an axle making a total load of about 30 tons. As the weight of a 50 ton coal car fully loaded is nearly 80 tons, the axles which were being used had all been in service under a static load of at least 20 tons, and as this load is increased from 50 to 100 per cent. by impact, no fears were felt as to the safety of these trucks for carrying the bridge, especially as that load would have no impact.

A few days before the bridge was ready to be moved longitudinally the trusses were jacked up and the rails and rollers which had been used for the side movement were removed and replaced by sand jacks. Each sand jack consisted of a box 10 in. high, the four sides, top and bottom being composed of 3 in. x 10 in. lumber held together by  $\frac{3}{4}$  in. bolts. The floor of the box was larger than the frame and the frame was slightly larger than the truss shoe, the top of the box being composed of loose pieces fitting within the sides. Each box was filled level with sand and the cover placed on before the truss shoes were let down. These jacks carried traffic for several days while the preparations for moving were being made. When everything was in readiness the bolts holding together the sides of the sand jacks were taken out and the sand removed from under the shoes, letting the spans down gently onto the trucks which had been provided with blocking under the stringers. The application of the weight to the trucks and falsework caused a settlement of the spans of about 3 in.

As an anchorage for the longitudinal movement several heavy bridge timbers had been buried behind the east abutment and both ends of a 1 in. cable led from the deadman to the backwall of the abutment. Two sheaves were attached to the projecting ends of these cables, two other sheaves were attached to the floor beam at the first panel point from the east end and lines were run through these sheaves to form nine part  $\frac{5}{8}$  in. steel cable on one side and four part  $1\frac{1}{4}$  in. manila rope on the other side. The lead lines were run to drums on hoisting engines mounted on flat cars anchored to the bridge. The sheaves were attached to the east span only. It was thought that the rails would form sufficient connection between the spans to pull the middle and west spans, but as an additional precaution, 12 in. x  $\frac{3}{8}$  in. plates were bolted to brackets projecting beyond the end floor beams of the spans over the piers making a continuous steel structure 540 ft. long.

While the sand jacks were being removed a derrick car removed the 125 ft. of temporary frame trestle at the east end and the bridge was ready to be moved. Simultaneous pull on all the lines was not sufficient to overcome the inertia of the bridge and the heavy pull broke the deadman cable. A new hitch was taken on it by digging down a short distance, jacks were placed against all the truss shoes and a locomotive set to push against a strut on the floor beam at the west end. Simultaneous application of all this power started the bridge and it rolled 123 ft. to the new pier in about three minutes. One difficulty arose during the movement of the spans which was caused by uneven cutoff of the falsework piles. The trucks, supporting one corner of a span before the movement started, rested on a high point in the falsework and during the movement rolled to a lower point causing the shoe at the end of the span to drop about  $\frac{1}{2}$  in. below the top of the new concrete pier which it should have cleared by about 3 in. For this reason the movement of the bridge had to be stopped about 3 ft. short of its final location and the I-beam grillage on the bottom of the shoe removed.

After the spans reached the new piers, wedges were driven under the shoes to carry traffic temporarily and the weight was not otherwise removed from the trucks. Within the next few days, however, each of the spans was jacked over into final position and the weight removed from the trucks. It had been

intended to fill the gap at the west end of the bridge by setting frame bents and timber trestle on the falsework over which the bridge had rolled, but on account of the interference that would have resulted in changing this trestle for the new steel floor, arrangements were made to keep the bridge out of service until the new steel floor could be placed. The steel was previously loaded on a barge and raised to position by a derrick car.

The longitudinal movement consumed more time than was anticipated. The track was cut at 10:25 a. m.; the work of removing the falsework at the east end, letting down the sand jacks and moving the bridge endwise consumed about three hours; then the afternoon was taken up in placing the steel floor system for the new span at the west end so the track could not be connected up again until 8:15 p. m. The erection of the new span at the west end followed immediately and the falsework in the main channels was removed as quickly as possible to prevent damage from the spring flood.

After the bridge was moved off of the old piers this old masonry was removed. After taking off the piers to water level holes were drilled in the piers and they were broken up by dynamite, the broken stone being dredged by clam shell buckets. In the removal of the footing courses and the rip rap surrounding the piers a great deal of old bridge iron and other debris had to be removed. At one time five pin joints of an old Union Pacific truss with all truss members, floor beams and bracing attached were raised from the river bed and suspended from the Missouri Pacific bridge. A heavy pull by a 100 ton steam wrecker failed to loosen up the parts extending down into the river bed and they were finally shot off by dynamite placed by a diver. The work of removing all obstruction down to a specified level required about six months.

## THE COLLEGE MAN AND THE RAILROADS.

By IVY L. LEE,

Executive Assistant, Pennsylvania Railroad.

I would direct your attention to the point brought out in a conversation I once had with W. M. Acworth, the distinguished English railway economist, who, after returning to London a few years ago, from attendance upon a meeting of the American Economic Association, made this observation:

I was surprised, hearing the college professors discuss the transportation question, to note how little they really knew of it. They understood the theory, but not the practice. And later, discussing the subject with railroad presidents, I was astonished at their lack of breadth. They understood the practice, but not the theory.

The demand of industry is for men who understand both the practice and the theory. Let me be concrete: It is the experience of the Pennsylvania Railroad that graduates who come to them from technical schools are deficient in three general particulars:

*First*, lack of practical experience and judgment;  
*Second*, an idea that they are far superior to the rest of mankind;

*Third*, a certain narrowness of mind, inculcated through a too exclusive attention in college to mathematics and theoretical science, and a too great neglect of those broader subjects, such as political economy, history and general literature.

Here are a few suggestions as to how these deficiencies may be met.

The question of practical experience might be remedied by the man serving two or three years as a machinist prior to going to a technical institute. Of course, this is not feasible in a large number of cases, and the man must get his actual experience after he starts regularly to work. But the college can implant in his mind certain sound fundamental ideas. A man who has had a good engineering education and has absorbed com-

\*Extracts from an address on "How Can the Colleges and the Railroads Co-operate?" delivered before the annual meeting of the Society for the Promotion of Engineering Education, at Minneapolis, Minn., June 26, 1913.

mercial ideas will make a good commercial engineer. One who is a theorist and scientific man only, with no commercial ideas, will make a good investigator, and possibly a good man in a test department, especially when engaged in scientific research; but even a good test department man requires some little idea of business, because test room questions are not settled on quality alone. The best quality for the same cost is the real question at issue. The man of great value to an industry is he who does not merely attempt to follow a theoretical ideal, but who adapts his theories to the actual limitations of the moment, and secures the best practicable result.

Men leaving technical institutions should be made to have a thorough understanding of the fact that they are necessarily almost completely lacking in a real knowledge of the practical application of the principles they have been studying. If a student can be trained by the time he completes his college course to have real openness of mind, he will be well on his way towards success when he leaves college. Young technical or educated men leaving school should, at the start, forget that they are men of scientific training, and tackle work precisely as do other workmen, knowing that when they have mastered that part of their education, the time spent in doing so will not have been wasted.

While it is not expected that technical men entering railroad shops shall have to consume as much time on menial or trivial work as those not possessing such advantages, nevertheless, to regard time spent in the shops as time lost in the pursuit of their true vocation is a very grave mistake, and results in many technical men not being advanced to a position of managing other men.

It is of the greatest importance, too, that students be impressed with the human elements in all industrial work; that is, they must realize that whatever their college education may have been, they are of very little real value until they have acquired something which few colleges teach. Too often young men come from our colleges with the feeling that they know too much to be told anything by men who have not had a college education. By assuming such a stand they close the mouths of men who could and would give them very useful information.

A beginner in the practical end of any line of work should be taught beforehand that college education is not everything, and that results can only be accomplished through other men. Therefore, he must get the viewpoint of other men before he can secure that sympathy from these other men on which his success as a manager will depend. In doing this, he will get much misinformation, which he will know to be such, but this knowledge he should keep to himself. We see all around us men holding the highest positions, who have come up from very small beginnings, with no apparent advantages. Yet we find that these men have the business at their finger tips, because they have been through all of the grades. The feeling that the possession of an education relieves a man from the necessity of going into these details has resulted in many men becoming nothing but technical advisers to carry out the wishes of other men who thoroughly understand the details of the work. Such merely technical advisers never share in the great rewards which come to the men who combine a mastery of both theory and practice.

It is of prime necessity, of course, that a man who is trained to practice engineering shall have a good engineering education. Successful men in railway engineering work must necessarily be familiar with the laws of nature, and the fundamentals of mathematics. This information can be obtained, however, outside of technical colleges, and the man who obtains his information in this manner, by the necessarily more concentrated application on his part, is generally a better engineer than a large per cent. of college graduates. Many competent judges believe that technical courses in the majority of the colleges lay too much stress on details. If more time were spent on the study of fundamental principles, it would result in developing more resourceful men. Some of our officers, in advising young men, have suggested to them that they devote their entire time to the study of mathematics,

physics, chemistry and English, and one foreign language, and not take up any particular branch of engineering. A student who is well grounded in these studies can take care of any proposition which will come before him. His resourcefulness will be developed by reason of his being compelled to work from principles rather than trying to fit the problem before him to some particular detailed case which he has learned in his engineering course.

Many of our officers hold the view that the best shop work for college men is that which can be obtained during the summer in the various shops where actual work is done, rather than having the time of the student taken up by the more or less imitation shop work that is done at some of the schools. The most valuable part of shop experience to a student is the coming in contact with men and absorbing their experience.

I asked not long ago the man who, I believe, is conceded to be the greatest expert in this country in railway electrification, to tell me what he really learned in college. His reply was,

I am inclined to think that the most valuable asset that I brought out of my college course was the habit of studious application to the job in hand, rather than a finished knowledge of any subject.

In the final analysis, gentlemen, the technical student has only time to acquire a fairly good grounding in principles of engineering. The college trained man, however, has an immense advantage after he obtains some experience over the non-technical man in being able quickly to grasp the relation between the theory and practice and to apply correct principles to practice.

Young men are frequently placed in positions for which they are entirely unsuited, while if they were moved to other positions more adapted to their make-up, they would often prove successful. Some of the very best men we have in our shops at Altoona in certain departments can never go higher because there is nothing for them to do in general railroad work that is suitable for them. In some of these cases, no other men on the road could fill their present positions as well as they do. The only thing for such a man to do is to leave the railroad and seek a position with a concern that can afford to pay more for the particular kind of ability possessed by him.

This is a day of social service. Never before were so many men being called for to act for the people at large in the control of industry, and particularly transportation. The Interstate Commerce Commission has just advertised for a large number of engineers to assist in the pending federal valuation of railroads. Never did a situation more strikingly illustrate the need for men with practical training. If the proposed valuation is carefully and wisely made, it will do great good. As Thomas F. Woodlock said, in a most illuminating article in the *New York Times Annalist* of June 23, "Practical confiscation—partial at least—of property actually invested in railroads will be quite possible by 'valuation' if the public is determined to do it, or if the 'valuers' are permitted to run riot among the technicalities." It is an occasion when practical men are needed, men capable of seeing facts as they are—and not with reference to any theories or past prejudices.

So men are being demanded for work with public service commissions, in colleges as teachers, in university settlement and municipal health work, in city governments, and in all those capacities where men can serve their fellow creatures. This is one of the hopeful signs of our times. But this is a period of great unrest. Many strange economic and political theories are being preached. It is a time when our young men should see that things cannot be always as they should be, but that our duty is to make them as good as we can.

Railroad managers for instance, would be delighted to equip every mile of road with automatic block signals, to make every car of all-steel, to remove all grade crossings, and otherwise avail themselves of every device to insure safety. But this cannot be done without the necessary money. So in all things, it is well to hitch our wagon to a star, but be sure that the connecting rope is long enough and elastic enough to let us keep the wheels on terra firma.

## B. L. WINCHELL.

B. L. Winchell has resigned as one of the receivers of the St. Louis & San Francisco to become director of traffic of the Union Pacific system. The change will become effective on July 14. Mr. Winchell's headquarters will be in Chicago, and he will report directly to Judge R. S. Lovett, chairman of the executive committee. The traffic local to the different lines composing the Union Pacific system will be in charge of the immediate officers of the respective lines. The director of traffic will have charge of traffic interchanged by the lines composing the Union Pacific system with other lines.

The readjustment in the traffic relations between the Union Pacific system and other railways that the dissolution of the Harriman system will cause makes the position of director of traffic of the former one of very great importance. The readjustment will stimulate competition between the various transcontinental lines, and it is with the aim of better enabling the Union Pacific to deal with this increased competition that Mr. Winchell has been made director of traffic.

While in more recent years Mr. Winchell has served the Rock Island and the Frisco as an operating and an executive officer, he is by no means a stranger to the traffic field. He began his railway career in the traffic department and was a traffic man until he became president and general manager of the Kansas City, Ft. Scott & Memphis in 1900. A sketch of Mr. Winchell, in which his many attractive and effective qualities both personally and as a railway officer were mentioned, was published in the *Railway Age Gazette* of December 10, 1909, page 1137. One of his most pronounced characteristics always has been his diplomacy and skill in dealing with connecting lines and with the public. Because of these characteristics he will be a very important addition to the official personnel of the Union Pacific. The Union Pacific system is universally recognized as one of the most efficient transportation machines in the country. It has had for years, and has now, a very strong organization which has been, and is, getting excellent results. Mr. Winchell will add to it an element which it has not possessed in the highest degree, and that is the ability not only to serve the public well, but also to make the system and its service as popular as they deserve to be.

While Mr. Winchell's jurisdiction will extend over the entire Union Pacific system, he will have no official title on the San Pedro, Los Angeles & Salt Lake because the Union Pacific owns only a half interest in this road. He will, however, act in an advisory capacity regarding traffic matters to the officers of the Salt Lake Route, which will become under the new conditions a more important factor in transcontinental business than it has been heretofore.

Mr. Winchell began railway work in July, 1874, as a clerk in the office of the superintendent of machinery of the Hannibal & St. Joseph. He was subsequently clerk in the auditor's

office of that road, chief clerk in the general freight and ticket office of the Atchison & Nebraska and assistant general passenger agent of the latter road until April, 1880, when he was made chief clerk in the general passenger department of the Kansas City, Ft. Scott & Gulf and the Kansas City, Lawrence & Southern Kansas. Three months later he was advanced to assistant general passenger and ticket agent of those roads, and from June, 1882, to May, 1895, he was assistant general passenger and ticket agent of the Kansas City, Ft. Scott & Memphis and the Kansas City, Memphis & Birmingham. He was then for three years general passenger and ticket agent of the Union Pacific, Denver & Gulf and the Denver, Leadville & Gunnison. On May 1, 1898, Mr. Winchell went to the St. Louis & San Francisco as general passenger agent, resigning in December of that year to become vice-president of the Colorado & Southern. He returned to the Kansas City, Ft. Scott & Memphis system in October, 1900, as president and general manager, and in August, 1902, he was made vice-president and general manager of the St. Louis & San Francisco system. In October of the following year he was chosen first vice-president of the St. Louis & San Francisco system, third vice-president of the Chicago, Rock Island & Pacific, and vice-president of the Chicago & Eastern Illinois and Evansville & Terre Haute. He was elected president of the Chicago, Rock Island & Pacific in April, 1904, and on December 1, 1909, was made president of the St. Louis & San Francisco lines and the Chicago & Eastern Illinois, which position he held until his recent appointment as one of the receivers of the St. Louis & San Francisco.



B. L. Winchell.

**THE CHINESE AND RAILWAY DEVELOPMENT.**—The Tientsin-Pukow Railway was originally designed to connect with Chinkiang, but the Northern Kiangsu merchants did not realize what huge benefits a railway would give them, so, when it was ultimately decided that instead of running to Chinkiang the line was to go to Pukow, there was very little opposition from the Northern Kiangsu people.

But now the rising prosperity of the districts where that Tientsin-Pukow line passes has demonstrated to them clearly the enormous value of railways. They have become aware of the fact that Nanking is getting a great volume of traffic which would have been theirs, and they are deploring their short-sightedness. The desire to make up their loss explains their enthusiasm at present in discussing railway schemes. It is reported that recently the Chinkiang and Yangchow merchants had a discussion about railway projects and are determined to have a railway of their own. Their plan was to build a line from Liuhaockow, opposite Chinkiang, to Siennumiao, the famous rice market. The promoters of this new railway line are reported to have raised enough funds to carry out this project, and it is expected that construction work on the line will soon be started. This short railway will be ultimately extended to Shaopo, to effect a junction with the Tsingkiang-pu-Tungchow Railway.



## GEORGIA GOVERNOR DENOUNCES LABOR UNIONS.

A severe denunciation of labor union tactics with special reference to the actions of strikers in a recent strike of employees of a Georgia railroad characterized the farewell message of Governor Joseph M. Brown of Georgia, delivered before the new legislature on June 25. Governor Brown declared that even in their gentler aspects the unions take the nature of a gigantic labor trust out of all accord with the modern movement toward the suppression of combinations and are a menace to all classes.

"It is a matter of public note," he said, "that the labor trust is the most widespread and aggressively exacting trust in America; politicians pander to it, statesmen stand in awe of it and the public seems helpless in its grasp. Why? Because it votes in blocks of thousands in almost every state in the Union. It is composed of allied organizations which stand against all others."

Discussing the Augusta riots in connection with the strike, he said that so long as the railroad attempted to carry out its obligations as a common carrier it was the duty of the state to resort to extreme measures to protect it in serving the public; that the strikers themselves were in open rebellion against the laws of Georgia, and ignored the cardinal principles of republican government when they attempted to throttle the railroad and inconvenience the public. "Compulsory arbitration should be required, and neither the management nor the employees of a public service corporation should be permitted to paralyze the powers of the public. As to the killing in Augusta of three men, who by their deeds defied the militia, the suppression of anarchy is the right and duty of all, and there come times when they must shoot it to death just as they shoot down foreign invaders."

The acts of the strikers in leaving the service and in virtually encouraging the formation of mobs to intimidate and personally assault those citizens in the common carriers that they induced to take the places they had vacated, represented logically, he said, a claim which can be expressed in these words: "This is your property, but it is my job on it. I and my partner, the Union, will defend our mutual rights to exclusive ownership of the position which we hold on your property. We will determine for you whom you shall hire and whom you shall not hire and what wages you shall pay. While it is true that we haven't invested a dollar in this public service utility and you have invested millions in it, yet we have vested rights in these positions, rights we have accrued by usurpation, and we will hold them while defying the laws of the state and subjecting the public to serious inconveniences and loss, even against you. On your property, chartered to serve the public, we are supreme over you, supreme over the public. Supreme over the law, the union label carries more authority than does your great seal of state."

He quoted statistics from the report of the Railroad Commission of Georgia, showing that under the wage scales of 1912 the number of railway employees in 1908 would have been paid \$3,668,725 more than they received in 1908, an average increase for each railroad employee in Georgia of more than \$105 per annum. "The individual wage scale further shows," he said, "that by far the largest increase in wages has been paid to employees belonging to labor unions; such as engineers, firemen, conductors, train hands, etc., and that while the average increase to each employee was \$105 per annum, the average increase to each member of a labor union, in some instances, doubtless approximated \$300 or more.

"Tens of thousands of other citizens who are not in these unions, therefore, are confronted by the fact that the unions are levying a tax upon them to the extent that they are forcing from the employer an inequitable proportion of the wages paid to the general classes in the state.

"If the state not only authorizes unions to exact a higher wage than others are receiving, but also permits them by authority of law or by winking at their violations of it to hold up the public and rob it of the facilities of transportation, then it cannot claim the right to protect any farmer or any other person employing labor against the employees who might strike, and proclaim to him that no one else shall work his crop for him. If the state says to owners of railroads, factories, etc., 'you shall pay tax on this property, which you have created or bought, but neither class shall control it, I hold you responsible for keeping it in condition for safely serving the public, but allow them the privilege of wrecking it, or of depriving the public of the use of it,' then how can she protect a farmer or any other citizen in the right to control his property?"

The governor stated it was not his aim to brand every member of labor unions as violators of the law. There were many law-abiding men, but they were all victims of a system which is breeding anarchy. He charged the system with "applying lynch law to billions of dollars' worth of property."

He urged upon the legislature the necessity of a law for compulsory arbitration, and suggested an amendment to the state code to require the sheriff of a county to notify the railroad commission of any act to attempt the stoppage of performance of duties for which a public service corporation was chartered, and to authorize the governor to issue a proclamation authorizing the sheriff to give protection; if necessary, by the aid of military authorities.

## SYSTEM AND ORGANIZATION IN STATION WORK.\*

At the small station, the agent lays the foundation for his future success. To a large extent he is left to his own resources with certain rules and instructions as a guide to the general work. His duties are many and varied and in order to successfully perform them, it is quite necessary that he map out a system adapted to his particular station. The most essential part of a system is to have a place for everything, and everything in its place, conveniently arranged for easy access without unnecessary steps.

The brief outline which we will describe would apply not only to the non-competitive station, but to the competitive station as well.

The work of the day should be commenced by arriving at the station at a certain and reasonable hour, not only one morning, but every morning. If there is an early train, the agent should reach the station in ample time to have everything in readiness for its arrival, whether it be the passenger or the way freight. The patrons and the agent's fellow employees will soon appreciate his regularity and promptness and will in many ways materially assist him in establishing a reputation for a system that assures promptness and despatch in every part of his organization. The agent upon whom rests the responsibility must not be unmindful that quality of service is more essential than volume in everyday accomplishment, and every inference here is intended to imply that meaning, and despatch and volume is second always to quality of service.

In the detail work of the office, such as the expensing and abstracting of way-bills, both in and outbound, the making up of the daily ticket sales and the remittances, etc., he should know on an average about how much time is required for the different work each day and set aside a certain hour for it, including errands uptown; in other words, know today just what time of the day he should have the various kinds of work done and out of the way tomorrow. He should train himself to work by schedule—circumstances may not permit him to follow it day in and day out, but the average will be

\*From the Monthly Bulletin of the Traffic Department, Chicago & North Western Railway.

in his favor. If the regular duties are taken care of, the irregular ones will be provided for by an extra time allotment. At the close of the week, a trial balance covering the cash transactions for the week should be made; even if it does add an extra hour to the daily schedule, the time will be well spent and noticeable at the end of the month. An extra hour or two of the last day should be spent in closing the ticket register for the month and copying the commencing numbers for the new month, list the uncollected freight bills to accompany the monthly balance sheet; totalling the Western Union, which has been entered up from day to day, also the cash book; making a trial balance of the entire month's business, after which the final remittance should be made. Another very important feature at each and every station, no matter how small, is the prompt reply to correspondence. Agents should make every effort to answer letters promptly, as delay in doing so often creates extra and unnecessary labor in various departments, such as tracing for lost freight or reports, etc.

Passing from the smaller to the larger station, practically the same system should be followed, but it is here that organization enters more fully into the work at the station, on account of two or more employees being required. Each individual clerk's ability and capacity should be studied and the work apportioned accordingly and the clerk held responsible for the work assigned to him. More than one person trying to do the same work will soon destroy the system as well as the organization, and will shift the responsibility and seriously affect the reputation of the agent, not for the amount of work he can do himself, and not for the amount of work he can secure from a fellow employee, but because he is at the head of an organization and as such will prove that he is unable to so properly conduct his business as to entitle him to consideration for higher service.

The foregoing all relates to clerical procedure, system and organization of office work, and at the close of the month the agent has an opportunity to survey the general situation through comparisons secured by abstract work and comparative reports, which he is usually obliged to make. We refer particularly to Form 110 in which he combines and compares each separate result for the month past, and equips himself with information necessary to answer all questions, as well as furnishing his superior officers with information. This gives him a line on which to base his future work, as this report develops any and all weaknesses and affords him the opportunity of concentrating his efforts on the weak points in solicitation, so that he may overcome a disability which may have been in effect for several preceding months, unless known and unless action has been taken by the agent to turn the tide.

A few hours of careful study of comparative results at the close of the month qualifies the agent for the future month's procedure, and if the above plan is carried out by the agent and the necessary outline of future action noted, it will bring him up to the manner of most successful solicitation. It is our opinion that this can be greatly aided by experience, care and perseverance, although the natural element that is a part of a soliciting element is perhaps more pronounced in this particular department than in any other part of the agent's duties.

**VICTORIAN RAILWAY IMPROVEMENTS.**—Traffic expansion on the Victoria Railways, together with the introduction of heavier types of rolling stock, has necessitated not only the entire substitution of heavier permanent way materials, but the renewal and strengthening of bridges. The manufacture of girders and bridge members in the state is unavoidably slow, and as this retards rapid strengthening of the structures before the train services can be improved, it is possible that if manufacturers were to make some proposition estimated on a wholesale basis, the commissioners would be well advised to accept, as the work would be completed quickly and not dragged out over a number of years.

**TESTS OF ALCOHOL HEATER CAR.**

In shipping perishable products during the winter months, some precaution must necessarily be taken to prevent their freezing, and the practice very commonly followed is to line box cars with building paper and equip them with false floor racks and small stoves. The objections urged against this practice are the initial cost for equipping the cars, which are not always returned for repeat loads, and the cost of attendance along the road, as well as the risk from damage by fire. Specially fitted heater cars are in use to some extent for such traffic, but the objection which is commonly raised against this type of car is that it is necessarily non-revenue producing for about nine months of the year, unless used as an ordinary box car during that time, and the heater car necessarily costs more than the ordinary box car.

A solution of the problem would seem to be a combination heater and refrigerator car that would be available for use the year round. There are several types of this car in existence, one of which has been developed by the Alcohol Heating & Lighting Company, Chicago, and was described in the

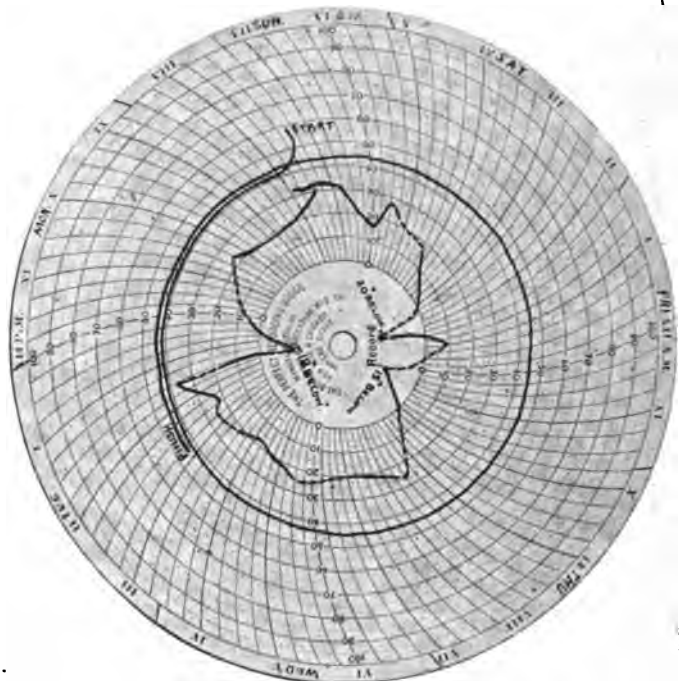

**Record of Temperature Test of Alcohol Heater Car.**

*Railway Age Gazette*, June 7, 1912, page 1244. After making tests with a number of fuels, it was concluded that denatured alcohol was the best adapted to the purpose in hand, as it does not vitiate the air to the same extent as other fuels, and it can be used as a heating agent without any detrimental effects on food products. Considerable time was spent in developing an automatic alcohol burner, and one was finally produced that could be safely operated for from eight to fifteen days without any attention other than an inspection made at divisional points.

These cars have now been in service during three winters, and the illustrations accompanying this article show the result of a temperature test made on one of them in use on the Canadian Pacific. The recording thermometer was placed in the car at 11 a. m., March 2, at which time the doors were closed and sealed, the car remaining in this condition until 8:30 p. m. March 11. The full line on the diagram represents the temperature inside the car, and it will be noted that it was maintained almost constantly between 40 and 45 deg., a variation of less than 5 deg., while the temperature outside varied 58 deg., as shown by the dotted line on the diagram. During this time the car traveled a distance of 1,475 miles.

The test was conducted under the direction of A. W.

Whiting, inspector of refrigeration of the Canadian Pacific, and was run between West St. John, N. B., and Fort William, Ont. The car was equipped with what is termed the double unit system, there being four burners, two on each side of the car. These burners are exactly the same, but for convenience in conducting the test were numbered one and two. By using four burners the maximum amount of heat can be applied quickly at the point of loading, and when the car and contents have been thoroughly warmed two of the burners are extinguished, the two remaining ones being sufficient to protect the lading. The duplicate system insures a longer run without the necessity of cleaning the burners; each burner will burn continuously for seven days without cleaning, and if the car is reconsigned it is only necessary to extinguish one burner and light the other.

The car was loaded with boxed merchandise to a height of about 4 ft., there being no space between the boxes or at the doors. Both the number one burners were lighted at 11 a. m., March 2, 1913, and a self-recording thermometer was placed inside of the car, 6 ft. back from the door, 2 ft. above the floor and 2 ft. from the side wall. The thermometer was surrounded entirely by freight in order to determine the temperature of the freight rather than the temperature of the air inside the car. The car left West St. John at 8:45 p. m. March 3, with the two number one burners in use; the number two burners were lighted at 8:45 p. m., March 4, at Megantic. The burners were inspected at each division terminal and were found to be operating satisfactorily in every case. The reservoirs were refilled once during the test, each box being supplied with 7½ gal. of alcohol at Smiths Falls, Ont., at 10:30 a. m., March 6, at which time the two number one burners were extinguished and the car continued to its destination with the two number two burners operating. The fuel reservoir can be made of any desired size, but it has been found in practice that four days' supply is the most economical and satisfactory on account of the character of the train schedules and the length of time that the perishable freight must be protected. On account of the location of the thermometer it is not probable that it could have been greatly influenced by the

warm air entering the car at either end, but instead received only the benefit of the warm air rising from the floor of the car. High winds and snowstorms prevailed at several points during the trip. The car arrived at Fort William, Ont., at 8:30 p. m., March 11, and the thermometer was then removed and the test closed. The burners were operated a total of nine days, ten hours, the actual running time of the test being eight days.

**A CITY THAT APPRECIATES A RAILROAD.**

Montclair, N. J., a city of about 25,000 inhabitants, enjoys the distinction of being at the end of a railroad, although it is only 15 miles from New York; and so it has a terminal station. The beautiful new station of the Delaware, Lackawanna & Western in that city was described in our last issue, page 9.

On the day of the opening of the station there was a large public meeting, attended by citizens and by officers of the railroad, and there was delivered to President W. H. Truesdale the following:

**AN APPRECIATION.**

*The Town of Montclair to the President of the Delaware, Lackawanna & Western Railroad Company and his Associate Officials.*

"The citizens of Montclair feeling a just pride and gratification in the completion of a notable civic improvement, desire to express to the president of the Delaware, Lackawanna & Western Railroad Company and his associate officials their appreciation of the generous spirit which has provided for the town a worthy approach and gateway, and to commend the manner in which the officials of the company have co-operated with the officials of the town in overcoming numerous difficulties and in providing a splendid public utility.

"Friendly co-operation for the general welfare has both constructive and instructive value. Of this fact the Lackawanna terminal is an enduring object lesson to the community. Its architectural beauty and commodious proportions, while showing the characteristic public spirit of the builders, also typify the stability and prospective growth of the community.

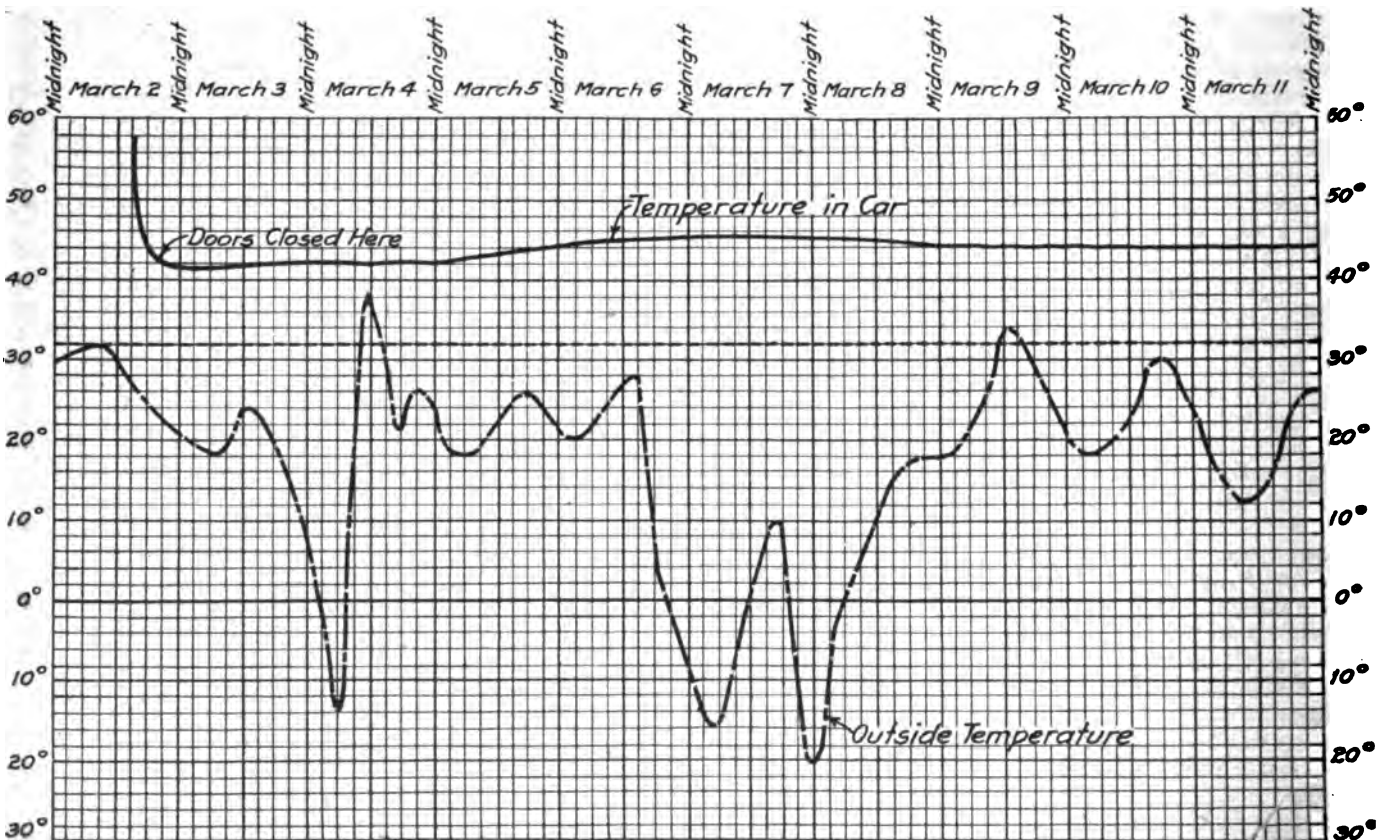

Diagram Made from Record of Recording Thermometer in Alcohol Heater Car Test.



condition of the roadbed, weather and other external influences. The figures derived from these experiments must be applied with knowledge and understanding. Ability to tell whether or not we have parallel cases depends largely upon experience in such matters, and considerable knowledge of applied mechanics.

To make a rough approximation, we must have, in addition to the gradient, the number of tracks, a profile of the engine district and the kind of motive power to be used.

If we have a single track road with say 1.0 per cent. grades which we wish to reduce to 0.3 per cent., what will happen? If we do not lower the summits we will gain very little advantage, insofar as fuel consumption is concerned, except that due to a more uniform velocity. The average speed will be slower as the locomotive will not start as rapidly and will not reach a high speed on level grades with the new rating. The time in making sidings will increase. If the locomotive is loaded with all it will start, it will not reach the terminus in the ten-hour 100-mile time limit or even in 16 hours on a single track. If, for the sake of illustration, we say that the fuel account per ton remains the same, it is apparent that the trainmen's wages will increase, the amount depending upon the running time plus the time in sidings, etc., which latter amount is again dependent upon the congestion of traffic or the number of tracks. The tonnage behind the engine will have to be reduced more for a single track line than for one with two tracks. The single track may get enough benefit to make the grade reduction pay, but it does not follow that the relative proportion of profit will be the same for different numbers of tracks. Because a four track road derives a profit from a reduction in grade it does not follow that the same thing will pay on a single track line. As a general rule, it may be stated that to get the full benefit of very flat grades the number of tracks should be increased at the same time.

When summits are lowered, the fuel bill will be reduced depending in amount largely upon the speed of approach. Each case must be worked out with reference to its particular location, and for that reason it will not be discussed here. The general rule may be stated that the amount of fuel will decrease as the speed of approach increases. If the speed on the grade is decreased, one may derive little profit, although considerable difference in elevation may have been made. On multiple tracks, the sidings are usually further apart and a greater speed can be maintained. For this reason the benefits to be derived on one line might not be a fair criterion on another with a different system of operating.

Lengths of engine districts are generally fixed by other elements than economy. Competition, location of towns, topography suitable for yards, etc., all enter into consideration. Having once been fixed, they can seldom be changed. If the projected improvement only affects one district the problem may be different than if several districts are involved. Trainmen are paid on a basis of 100 miles. If the district is shorter than this, it will pay to give the locomotive a load that will take ten hours to haul between terminals provided it is not greater than it can start at all its usual stopping places. If a district is 120 miles in length, it may be run in twelve hours and must be in less than sixteen. With the shorter district it may pay to reduce the grade to make the grade resistance equal to the starting resistance. However, it does not follow that the same operation would pay equally well in the second case. As a general rule, short engine districts offer a greater opportunity for the development of low gradients than long ones.

Another feature to be taken into consideration is the locomotive to be used. The ability of the locomotive to get its train over the road on time is dependent upon its boiler capacity and not upon its tractive power in starting, as illustrated in the accompanying curves. The tractive power of a locomotive at starting is usually calculated from the formula  $0.8 P d^3$  where

D

P = Steam pressure.

d = Diameter of cylinder in inches.

s = Stroke in inches.

D = Diameter of driving wheels in inches.

Inspection shows that the tractive power increases as the diameter of the wheels decreases. This is true at starting, but as the speed increases, the limit of full cut-off will be reached at a lower speed with the smaller driver. In the illustration this is the point where the power line changes from a straight line to a curve. Engine H 8 A is a consolidation type locomotive and full cut off can be maintained by its boiler at about 5 m. p. h. above which the drawbar pull falls off rapidly. The Mallet shown can start nearly twice as much as the consolidation, but has only about the same power at 20 m. p. h. If one must make an average speed on a district of 20 m. p. h., the question of how much the Mallet can start on a given grade has but little bearing on the subject from an economical standpoint. When the speed rises the adhesion falls to about 0.20 of the weight on drivers. The adhesion need only equal the train resistance. From this it is seen that the heavier engine is carrying a good deal of excess weight except at very slow speeds.

The electric locomotive No. 1 New Type has a tractive power at starting which is less than that of the consolidation, but can maintain this power until 17 m. p. h. is reached. The electric locomotive would probably be able to arrive inside the time limit with all it could start when the consolidation and the Mallet would not. This is an extreme case, but it illustrates the idea that the locomotive to be used as a criterion should be properly designed for the engine district. The electric locomotive will be with us some time in the future and its peculiarities should be considered when large expenditures are made.

The only correct method of handling the subject in the opinion of the writer is to devise a set of tables of accelerations and retardations (See *Railway Age Gazette* of August 23, 1912), or curves showing the same thing graphically. From these speed curves can be made for any given engine and load on any profile. They duplicate the train movement, and the comparison of the loads will give a basis for computation along economic lines.

It is easy enough to say that when the starting resistance is 13 lbs. per ton we may fix the economic grade by the following:

$$\begin{array}{rcccc} \text{Starting Resistance} & = & \text{Grade Resistance} & + & \text{Train Resistance} \\ 13 & = & & + & 6 \\ & \times & = & 7 & \end{array}$$

Equivalent grade is 0.35 per cent.

All this shows is that on a +0.35 per cent. grade the sidings should be level or on a minus grade when the engine is rated at all it can start.

In this connection, attention may be called to the fact that gravity furnishes the only power that a railroad gets for nothing. It can be used both to stop and start trains. All trains should stop just beyond the apex of a grade for ease in starting. This should not be done with the expectation that the engine will haul more in summer, but it will increase the rating for the winter months. If it is necessary to put a siding on a maximum grade for the use of up-bound trains, it should be operated from one end and lead out along the face of a hill. The train would back into it and a slight adverse grade would aid starting again in cold weather. It seems difficult to anticipate all the needs of block signaling, but it does not seem difficult to build humps for them. The advent of the electric locomotive will change conditions in a good many ways, and it now seems probable that they will be given such a load that they can cover two of our present districts with one train crew.

In conclusion, the statement may be made that the problem is one of virtual grades and speed curves so surrounded by operating conditions that it is unsafe to draw conclusions from similarities based on grade lines alone.

RAILWAYS PROJECTED IN ITALIAN SOMALILAND.—The Colonial Ministry of Italy has sent an engineer to Benadir, Italian Somaliland, Africa, to study the plan for construction of railways in Benadir.

**BOX CAR FOR GRAIN AND COAL TRAFFIC.**

The construction of a suitable grain door has always been one of the most difficult problems in car design. Such a door should hold grain as securely as any other part of the car body, should be immediately available when required, should not be demol-

ished in unloading, nor obstruct or decrease the lading room when not in use, and should be of reasonable first cost and low cost of maintenance. To meet these requirements the Canadian Pacific has built

200 Burnett hopper bottom grain cars, which embody several new features. The hinge of the hopper door is made by interlocking the edge of the door and the car floor, making a continuous hinge, which, instead of weakening the edge strengthens it as would the application of an angle, and the load always has a tendency to tighten the joint. The hopper door also differs

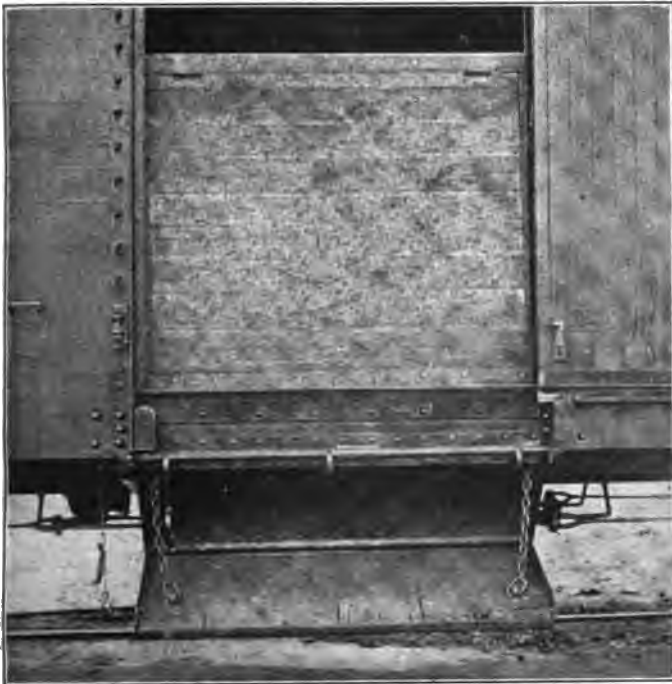

Exterior of Car with Hopper Open and Grain Door in place.

Interior of Box Car Showing Grain Door and One Open Hopper.

ished in unloading, nor obstruct or decrease the lading room when not in use, and should be of reasonable first cost and low cost of maintenance.

from previous designs in that it is hinged at the bottom and is almost vertical; it has no closing shaft but is closed by hand and secured by a shaft having projections which engage the edge of the door at different points. The ends of the doors

To meet these requirements the Canadian Pacific has built



Canadian Pacific Hopper Bottom Box Car for Grain and Coal Traffic.

have flanges which enter pockets or grooves formed by plates on the ends of the hopper. The grain doors are formed by sections of the floor at the doorway folding against the door posts. These doors are thoroughly reinforced and should be easily maintained in good condition. The whole construction is simple and strong, and as the hoppers are not subject to corrosion to the same extent as those of open coal cars, they should, excluding damage in wrecks, last the life of the car. In building the cars, each hopper is filled with flaxseed, which is then hammered and the hoppers are made absolutely tight under this test; it is claimed that this is the most severe test possible with the exception of water.

One of the principal reasons for the development of this car was to secure one which would be suitable for carrying coal in one direction and grain in the other, avoiding to a large extent empty mileage and the hauling of other cars for coal.

In dumping grain the same elevator arrangement is used as with the ordinary car. To unload a car of grain, the pin which holds the clamping shaft handle is driven out, which allows the hopper door to open and about 50 per cent. of the load runs out almost as fast as the elevator can take it away; the floor door is then unlatched and pushed down and the remainder of the load is taken out through the side doors in the usual manner. It has been found that the employment of this method saves about one-third of the time which it ordinarily takes to unload a box car.

The hopper door arrangement increases the weight of the car about 800 lbs. compared with a car not fitted with grain door equipment, but when compared with a car fitted in the ordinary way for grain traffic this difference is reduced by the weight of the grain door and fittings. The cost of maintenance of the ordinary door and fittings, including the usual nailing strips on the door posts, has been estimated at from \$6 per car per year upward, which is eliminated in the hopper bottom car. The additional cost of applying the hopper bottom and folding grain doors is approximately \$50 per car. Where ordinary grain doors are used a force of men is engaged at elevators in removing nails from the door posts and inside lining and getting the cars ready for load, while with the hopper bottom car this force, as well as the shipping of temporary grain doors back to the point of loading, is almost entirely done away with, thus effecting an additional saving.

Short sections of Z-bars are applied on the inside of the door posts above the folding grain doors so that when the lading extends to a point higher than the folding doors, boards can be dropped into the slots thus formed and the load carried to any desired height.

These cars are giving excellent satisfaction in service and are sought by the elevator men in preference to other cars. The hopper and grain door arrangement is the invention of R. W. Burnett, general master car builder, Canadian Pacific, and is being patented by him.

**PROJECTED CHINESE LINES.**—There are at present three projected railways in northern Kiangsu, including the short line from Liuhaokow to Siennumiao. This short line will bring Yangchow and Siennumiao into close touch with Tungchow in the east and Tsingkiang-pu in the north. It will also enable the northern cities to get into quick communication with southern cities through Chinkiang, which is on the Shanghai-Nanking Railway. The Tsingkiang-pu-Tungchow line will pass through the following cities: Tsingkiang-pu, Hwaiian-fu, Paoying, Kaoyu, Shaopo, Taichow-ku, Rukao and Tungchow. On the completion of the Tungchow line an extension may be made to Haimenting. Haimenting, Hwaiian-fu, Yangchow and Haimenting are salt manufacturing centers, and there is no doubt that these projected railways will have an important bearing on the salt transportation problem. The railway will give rapid transit, regular and efficient service and cheaper freight, and the government will reap great financial benefits by it.

## RAILROAD COST AND EFFICIENCY.

BY A STUDENT.

The possibility of allocating, either to the freight or passenger service, the many different items of cost in railroad operation has a very vital significance in the attempt to determine the cost of any particular service. It is universally agreed that a portion of the expenses cannot be allocated except upon the merest guess work, but as to how large a portion is indivisible is still the subject of dispute; I am inclined to accept the conclusions of Mr. Ackworth, who writes as follows concerning maintenance of way and structures:

"With the exception that a portion of the expenditure on stations and buildings can be allocated to passengers and goods, respectively, the whole of this expenditure is incurred not for any separate class of traffic, still less for any of the separate components of that class, but for the traffic of the line as a whole."

Concerning maintenance of equipment:

"So far, then, we have analyzed an expenditure of . . . and found that roughly three-quarters of it is incurred on behalf of the traffic as a whole, and only one-fourth can be allocated even to the extent of dividing passengers from goods, and that this quarter itself is not practically susceptible of any further detailed allocation."

Concerning conducting of transportation:

"Once more it will be noticed that only two items of quite trifling importance, 'loss and damage' and 'injuries to persons,' have any specific reference to passenger or goods traffic, respectively. The point must not be pushed too far. No doubt a much larger portion of the expenditure could be apportioned. A driver drives either a passenger or a goods train, and his wages might be apportioned accordingly.

"As the result, then, of our inquiry into railway expenditure the conclusion seems naturally to emerge as we reached in the case of railway capital. The bulk of the expenditure is incurred on behalf of the traffic as a whole; only a small portion can be even allocated so far as to say that it belongs wholly to passenger, or wholly to goods."

With the manifest impossibility of making accurate allocations, which would be acceptable to opposing interests, would it not be better to turn attention to combining the two services as an alternative method?

The railroad is a manufacturing entity with product of two distinct types, namely, the transportation of freight and the carriage of passengers. To ascertain its gross product it is necessary to find a method for reducing the units in each class of service to a common denominator. At the present time there exists no physical means by which a ratio between a passenger unit and a freight unit can be determined, consequently some other means of arriving at their relative value must be sought.

The law of supply and demand, which takes into account all conditions between the buyer and seller, the producer and the consumer, a vital part of which is the price, or rate; a law, which is effective in the market for service given by the railroads as in all other departments of human exchange, would seem to give the means for constructing a measure by which to approximate a true ratio between the two classes of service.

In any market the revenue rate per passenger mile and per freight ton mile is what the community will give up to secure the service, and exhibits the value of that service. The rates for both services may be more than is necessary to give a fair return upon the capital actually used in the service, or there may be inequalities between the relative charges for either service, without materially affecting results obtained through use of the ratio; particularly is this true when the ratio is obtained by using the average rates over a large territory.

Taking the Interstate Commerce Commission's statistical report for the year 1910, we find the average rates to be as follows:

Group.	Passenger.	Freight.	Ratio.
1	1.718	1.115	1.45
2	1.695	.641	2.64
3	1.846	.588	3.14
4	2.176	.655	3.32
5	2.256	.802	2.82
6	1.887	.751	2.51
7	2.073	.945	2.19
8	2.079	.971	2.14
9	2.321	1.056	2.19
10	2.291	1.196	1.94
All United States	1.938	.753	2.58

It is, of course, known that such averages are merely arithmetic, that no traffic is carried at exactly these rates, that the charge upon any particular class (commutation, through or local tickets, silk, satin, or ore rates) bears no definite relation to this general average. If the data of ton miles and passenger miles, segregated to the respective rates, were available, we could obtain, by weighing, not only a more accurate average, but also the mode, and mean, in each class of service, and these would give bases for many enlightening deductions, which are not now possible.

As will be seen above, traffic conditions in different territories bring about a difference in the ratio between the classes; for instance, in New England the freight traffic is largely local and of a high class of commodities; it therefore approaches more nearly the passenger class, requiring only 1.54 ton miles to equal in value one passenger mile; on the other hand, Group 4, with the lowest amount of passenger service and an average class of freight traffic, shows that it requires 3.32 freight ton miles to equal a passenger mile.

It would be manifestly improper to form any conclusions as to reasonableness of rates in either service from this ratio; passenger trains must be run upon necessary schedules whether passengers present themselves or not, rates on freight must be adjusted to the character of the commodities available for transportation, that is, to the value of the service, so that the large ratio in case of Group 4 may, or may not, be justified by the conditions in that territory; yet in view of all the elements comprised in the law of supply and demand, which includes the fixing of rates at which the consumer will take the service offered, it is logical to assume that the burden upon the two types of service is approximately the same as is their respective value to the community which consumes them.

At any rate, it gives a uniform measure by which to test the efficiency of operation on the railroads serving that territory.

Using a constant, say 100, to secure a larger divisor, and by which to equate the two classes of service for a common denominator, the following formula is developed:

$$\frac{100}{\text{The market rate per pass-mile}} = \text{one passenger unit.}$$

$$\frac{100}{\text{The market rate per ton-mile}} = \text{one freight unit.}$$

$$\frac{\text{Passenger miles}}{\text{Passenger unit}} + \frac{\text{Freight ton-miles}}{\text{Freight unit}} = \left\{ \begin{array}{l} \text{Total service units} \\ \text{of equated value.} \end{array} \right.$$

Here we have the total product of any road to which the formula is applied, and comparison of expenses per unit, and of utilization of power and carrying capacity for all roads within the same territory and subject to the same market conditions, may be derived.

Possibly an illustration taken from some other field may remove preconceived relationships and exhibit the process in a clearer light. Take the case of two farmers whose expenses are indivisible and assume that their product is confined to apples and potatoes; that the market rate for apples is two cents each and for potatoes 0.8 cents each. Here we have an example that is analogous to the railroad situation:

Farmer A produces 20,000 apples and 160,000 potatoes.  
Farmer B produces 30,000 apples and 120,000 potatoes.

A's apples being above the average bring him 2.5 cents each, his potatoes the normal market rate.

B's apples are inferior and he can get but 1.75 cents each, his potatoes are better and bring him .95 each.

Their expenses are: A, \$1,000; B, \$800. Using the formula, we find:

$$\text{A's apples} \dots\dots\dots \frac{20,000}{50} = 400 \text{ apple units}$$

$$\text{potatoes} \dots\dots\dots \frac{160,000}{125} = 1,280 \text{ potato units}$$

Total units produced... 1,680

$$\text{B's apples} \dots\dots\dots \frac{30,000}{50} = 600 \text{ apple units}$$

$$\text{potatoes} \dots\dots\dots \frac{120,000}{125} = 960 \text{ potato units}$$

Total units produced... 1,560

COSTS PER UNIT.

$$\text{A's } \frac{\$1,000.00}{1680} = 59.52 \text{ cents} \quad \text{B's } \frac{\$800.00}{1560} = 51.25 \text{ cents}$$

The costs per unit here obtained have no connection with the price that the two farmers received for their produce, as will be seen by:

A's apples at 2.5 cents	\$500.00
Potatoes at .8 cents	1,280.00
Total	\$1,780.00
B's apples at 1.75 cents	\$525.00
Potatoes at .95 cents	1,140.00
Total	\$1,665.00

Applying this method to the railroad costs, and using the market rate for the territory served, gives a very close approximation to the aggregate of physical units in the total product; it would require a very decided change in the average rate to materially affect the relative measurement of the passenger and freight units.

Taking the average rates as given above for the different groups and equating them by the use of the constant 100, we obtain the following results:

Group.	Passenger miles to unit.	Ton miles to unit.
1	58.2	89.7
2	59	156
3	54.1	170
4	46	152.7
5	44.3	124.7
6	53	133.1
7	48.2	105.8
8	48.1	103
9	43.1	94.7
10	43.7	80.5
All United States	51.7	133

As the ratio of rates is practically stable in the same territory from year to year, it is immaterial which year is taken as a basis.

Taking any road and dividing its passenger miles and the freight ton miles by their respective units and adding results gives the total number of physical units given by that road from which the costs per unit can be obtained.

Railroads in serving the community produce the units absorbed by that community; some at a high cost per unit and some at a low cost per unit; according to the internal, or external, conditions under which they work.

There is little, if any, connection between this unit cost and the revenue received for any class of traffic, therefore no attempt should be made to allocate these costs to the different classes of traffic; even though tests show that a division of the expenses for conducting transportation, made by multiplying the passenger units by cost per unit, agrees very closely with the auditor's determination, where he can most surely make accurate segregation. This tends to corroborate the essential relation between costs and the value of the service as expressed in the average rate. The only contention here made is that by reducing passenger miles and freight ton miles to a common denominator the gross physical service units produced by any railroad can be determined, and, with this product as a divisor, not only the costs but the relative efficiency of operation may be determined within a small margin of error.



## TRANSPORTATION AND CAR ACCOUNTING OFFICERS.

The summer meeting of the Association of Transportation and Car Accounting Officers was held at Charlevoix, Mich., June 25 and 26, with 97 members present and President J. M. Daly in the chair. At the opening session an address was given by A. Patriarche, assistant to the president of the Pere Marquette. Mr. Patriarche spoke of the greatness of Michigan and concluded his remarks with a brief outline of early railroad history in the state, showing the vast growth of transportation facilities. The association was also addressed by Col. B. W. Dunn, chief inspector of the bureau of explosives. Col. Dunn outlined the origin of the bureau and the work accomplished to date, showing the great reduction in the loss of life and property. He gave details as to instructions to agents and other railroad employees handling dynamite and other dangerous articles, and showed by photographs the wonderful improvement made in the transportation of dynamite, etc., since the enforcement of uniform rules.

The executive committee reported a membership operating 257,679 miles, and having in service 2,582,190 cars. Seventeen additional railroads were admitted to membership at this meeting. The association approved the action of the executive committee in its recommendation to the American Railway Association, that any adjustment found necessary under the elimination of per diem Rule 5 should be by action of the executive or traffic departments.

Forms proposed by the committee on car service, to be used by shippers in ordering empty cars, were returned to the committee for further consideration. The opinion of the committee on car service that a continuous home route card is impracticable was not concurred in by the association, and the executive committee was directed to appoint a special committee to study the subject. The recommendation of the committee with regard to proposed addition to Rule 15, of the code of car service rules, was adopted for submission to the American Railway Association, as follows:

"First—The delivering road shall pay cost of transfer or rearrangement—

"C—When transfer is necessary for the protection of perishable freight."

The recommendation of the committee on car service, that Rules 7 and 8, of the code of per diem rules (pertaining to the application of per diem on cars handled under M. C. B. home route cards, and cars held awaiting receipt of repair material from owner), be abolished, and a new rule substituted therefor, was returned to the committee for further consideration. The action of the committee in recommending to the American Railway Association certain changes in the definitions with reference to the terms "member road" and "non-member road" as previously recommended by this organization in its proposed amendment of Rule 6, of the code of per diem rules, was approved by the association. The recommendation of the committee that the term "inside height" as applied to closed cars should show the measurement from floor to carline at side of car, and that where figures carried in registration do not represent that particular measurement they be revised accordingly, was approved by the association. The association adopted for submission to the American Railway Association a proposed form of agreement between railroad companies and consignees to apply where other than written notice of arrival of freight is requested. The association adopted, for submission to the American Railway Association, the recommendation of the committee on car service that, where cars are held under per diem rules 14 and 15, a charge of not less than 45 cents per car per day (to be determined by per diem reclaims accepted) be paid to the holding road by the connecting line failing to accept cars at junction point, in addition to the reclaim already provided

for by per diem Rules 14 and 15. The recommendation of the committee on car service that no reclaims should be presented or allowed under Rule 15, of the code of car service rules, was adopted by the association for submission to the American Railway Association. (Rule 15 relates to the transfer or rearrangement of lading at junction points.)

The committee on office methods and accounting reported that 299 private car companies have to date adopted the reporting marks assigned by the committee, and are applying them to their cars. The assignment of these marks by the committee is under authority of the American Railway Association. The committee submitted in the appendix to its report a list of private car owners in the United States, Canada and Mexico, as compiled from the committee records. The association approved the action of the committee in recommending to the American Railway Association that the wording of Rule 9 of the code of per diem rules be changed so as to make it clear that interchange reports should be numbered consecutively for each connecting line. The recommendation of the committee on office methods and accounting, that junction card Form D1 be changed to permit of the form being used either as a junction card for the purpose of reporting junction movements thereon, or for the purpose of attaching thereto the cut-up slips obtained from the self-transcribing form of interchange report, was approved by the association for submission to the American Railway Association. The form submitted by the committee was also approved. The recommendation of the committee that interchange report Form B1 be printed on distinctive colors of paper and that the colors be pink for delivered and canary for received, was adopted for submission to the American Railway Association.

The report of the committee on handling railroad business mail, indicating a method for eliminating envelopes in the handling of certain reports on home roads by the use of a small paster for sealing the open edges of the folded report, was accepted.

The blank submitted by the committee on conducting freight transportation for reporting cars set back to connections, and the recommendation that a charge be made against the erring road for each car delivered in error, were adopted for submission to the American Railway Association.

The code of car service rules covering the handling of passenger equipment cars, as submitted by the committee on conducting passenger transportation, was adopted, with some modifications, for submission to the American Railway Association.

Officers for the ensuing year were elected as follows: President, F. Price (Grand Trunk); first vice-president, J. M. O'Day (Illinois Central); second vice-president, J. T. King (Atlantic Coast Line); secretary, G. P. Conard, 75 Church street, New York; treasurer, F. M. Luce.

The next meeting of the association will be held at Galveston, Tex., December 9 and 10 next.

## ARMOUR FAVORS RATE ADVANCES.

J. Ogden Armour, president of Armour & Company, on returning from Europe recently, was quoted as saying that he favored granting the request of the railways for an increase in rates. "All rates should be increased at once," said Mr. Armour. "They are far too low for the investors to get a fair return on their investment, and increases in the rates would result in an immediate improvement in all branches of trade and commerce. Everybody should be willing to have the rates raised, when all would find improvement and everybody would profit thereby. There is too much interference in this country by the government in the manner in which the railroads conduct their business and the rates for the carriage of all sorts of freight are now far too low. I, as a shipper, would like to see the rates increased, and all men of business ought to feel that way."

## PROPOSED NEW RAILROAD LAW IN MAINE.

The Legislature of Maine has passed a law to establish a public utilities commission in place of the railroad commission, and the law was to have gone into effect this week (July 12); but it is expected that when the governor and council meet on Saturday to make the preliminary arrangements, they will be handed a petition, signed by ten thousand voters, asking that the law be submitted to a referendum. It is understood that the ten thousand names have already been secured, and that, therefore, the present railroad commission and the water storage commission will continue in office until an election can be held.

The next step after the filing of the petition, according to the provision of Maine's initiative and referendum law, will be for the governor to name a date for a special election to vote on the act. This special election cannot be held sooner than four months after the notification by the governor, that is, not earlier than next November. In case the governor does not name a date for a special election, the voters will register their opinions on the matter at the next general election, to be held in September, 1914.

Opponents of the public utilities act, who are mostly on the Democratic side, the principal proponents of the measure being Republicans, make objection to the fact that the appointees on the board will all be lawyers, who, they say, have not had experience in the matters they are called upon to decide. They further add that the commission will cost the state \$100,000 a year, and is an unnecessary expense. They do not offer anything in place of the act, saying that the present state of affairs is satisfactory.

The new law, which is Chapter 129, consists of 72 sections, and in general contains all of the stringent and the sweeping provisions which have been embodied in recent state statutes of this kind, such as those of New York, Massachusetts and West Virginia. We note its salient features.

The governor is to appoint three commissioners, who are to be confirmed by the council. The governor designates one as chairman, and the term of each will be seven years, the terms of different commissioners to overlap. Salary of chairman, \$5,000; each other commissioner, \$4,500; clerk, \$2,500; assistant clerk, \$1,500. The law applies to railroads, street railroads, express companies, car companies, car loaning companies, and every instrumentality of a common carrier; gas plants, electric plants, telephone and telegraph lines, water companies, wharfingers and warehousemen. The commission will have authority to inquire into the management of the business of all these, and every public carrier, and public utility must furnish all desired information or give reasons for failure to do so. The commission is to report to the attorney general all violations of the law, and county attorneys, on request, must aid the commission in investigations. Every public utility must furnish safe, reasonable and adequate facilities, and demand only reasonable and just rates.

The commission, in prescribing forms for accounts, shall "consider" any system of accounting established by any federal authority, and any system authorized by a national association of utilities (i. e., the association of railroad accountants and that of electric railroad accountants). Any public utility engaged in a subsidiary business shall, if ordered by the commission, keep separate accounts thereof. No public utility shall keep any account, paper or record except as approved by the commission; but no requirements shall be made conflicting with the federal law.

Every public utility must file tariffs, and the rates must not exceed those which were in force January 1 last. Tariffs shall be published to such extent as the commission shall deem necessary. Rates in tariffs must not be changed except on ten days notice and publication. All rates not shown in tariffs are unlawful.

Section 27 is a revision of Section 55 of the existing law, regulating the organization of corporations to operate telegraphs and telephones, or to make or supply gas or electricity.

Section 32 prohibits rebates, discrimination, etc. Free transpor-

ation, reduced rates, etc., are prohibited, with exceptions like those in the federal law.

Section 33 provides for the investigation of any accident resulting in loss of human life, on the premises of any public utility, arising from its maintenance or operation.

Section 34 empowers the commission to fix a reasonable value upon property of any public utility used or required to be used in its service, whenever it deems a valuation thereof to be necessary for the fixing of rates.

Section 35 regulates the issuance of stocks, bonds, etc., which must be approved by the commission. The commission may, at the request of any public utility, approve the issue of stocks or bonds heretofore authorized but not issued. All sales or leases of property shall be subject to approval of the commission. No public utility shall purchase or acquire any part of the capital stock of any other public utility, etc., without authority from the commission.

The commission may order physical connections of telegraph and telephone lines. It may authorize one public utility to use the tracks, conduits, wires, etc., of another public utility in any public street, under suitable restrictions.

Section 41, which provides for making complaints, calls for a written statement, signed by ten persons, firms, corporations or associations who are aggrieved. When rates or service are found insufficient or discriminatory the commission shall have power to fix and order reasonable rates, service, etc. When a rate is changed by the commission the public utility shall not thereafter make further changes without an order from the commission.

The commission may, on its own motion, investigate whenever it is believed that any rate is unjust or unreasonable or any service is inadequate, or cannot be obtained.

Questions of law may be raised by alleging exceptions to the ruling of the commission, and the cases carried to the Supreme Judicial Court. While questions of law are pending on exceptions, no injunction shall be issued to suspend or stay an order of the commission. No person shall be excused from testifying on the ground that the testimony may tend to incriminate him or to subject him to a penalty; and no person so testifying shall be prosecuted except for perjury.

Section 60 authorizes the commission, in emergencies, to temporarily suspend existing rates or orders.

The maximum penalty for violation of the law is \$1,000 for each offense; but a director officer who authorizes the issue of stocks, notes, etc., contrary to this law, shall be liable to imprisonment for not less than one year nor more than ten years; and making a false statement to secure the issue of stock, etc., is subject to fine and imprisonment.

No public utility shall apply to the legislature for anything which the commission can grant until it shall have first exhausted its rights in that behalf before the commission.

**QUEENSLAND RAILWAY EXTENSION.**—Queensland has entered upon a policy of railway extension which will result in hundreds of thousands of acres being opened up for settlement. The new line from Oakey to Cooyar, which has just been opened by the Minister of Railways, is 38½ miles in length, and for its whole length it may be said to open up agricultural country capable of vast development, and on the Cooyar side of the range it taps country teeming with valuable timber.

**INDIAN RAILWAYS IN 1912.**—Indian railways as a whole enjoyed, in 1912, the best year they have experienced both in the matter of gross and net earnings and in the percentage of net earnings to capital outlay on open lines, which, at 6.77 per cent. was considerably higher than the return of 6.07 per cent. obtained in the exceptional year 1905. This return of 6.77 per cent. is exceedingly satisfactory, comparing as it does with 5.87 per cent. in the previous year. To the state itself the net earnings from state and guaranteed lines yielded a return of 5.19 per cent. on capital as against 4.37 per cent. in 1911.

## TURNTABLE TRACTOR.

The illustrations show a type of turntable tractor which is made by the Weir & Craig Manufacturing Company, Chicago. It is designed to readily move the largest turntables when loaded with Mallet or other heavy locomotives and also to stand practically as an independent unit on the pit rail, so that no shock or vibration will be communicated to it or any of its parts when the locomotive is placed on the table; this is obtained by connecting the main frame to the table by sliding links.

Trouble has been experienced in some designs of tractor owing to the fact that the entire machine was pivoted on one wheel and a comparatively rigid connection made to the table. Con-

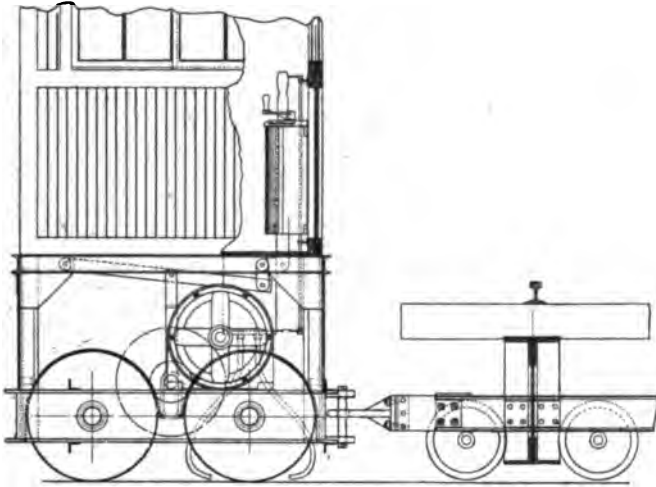

Fig. 1—Turntable Balanced, with Truck Wheels Slightly Above Rail.

siderable shock and vibration was thus communicated to the tractor, causing trouble with the wiring to the motor and the controller, as well as with the bearings and other parts, and this method of eliminating the vibration should reduce the cost of maintenance and increase the efficiency of the device. The tractor is designed, primarily, for electric power but may be equipped with a compressed air motor if electricity is not avail-

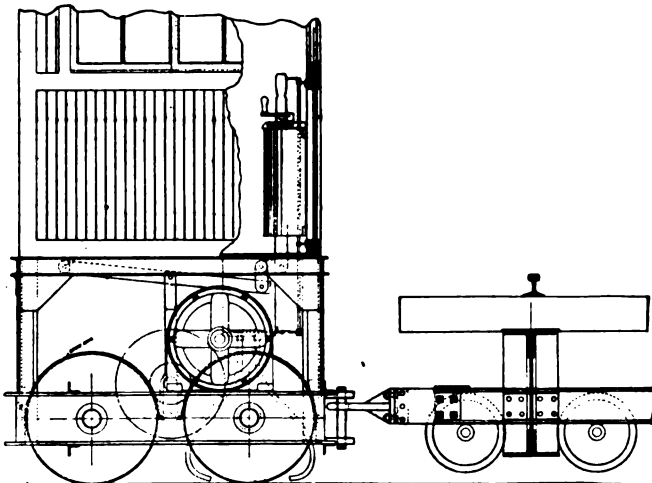

Fig. 2—Turntable in Its Highest Position Relative to the Tractor.

able, in which event the air motor may be replaced by an electric motor at any later time without alterations to the remainder of the machine.

By reference to the diagrams it will be seen that the tractor remains on the rail in its normal position, regardless of any vertical movement of the table. Fig. 1 shows the table balanced

with the truck wheels slightly above the rail; in this position the sliding link connection is in line with the main portion of the frame. Fig. 2 shows the table in the highest position, caused by a locomotive passing on at the opposite end, the sliding connection in this case being at the upper portion of the frame. Fig. 3 shows the table in the lowest position, the reverse of Fig. 2, with the truck wheels resting on the track, a position assumed

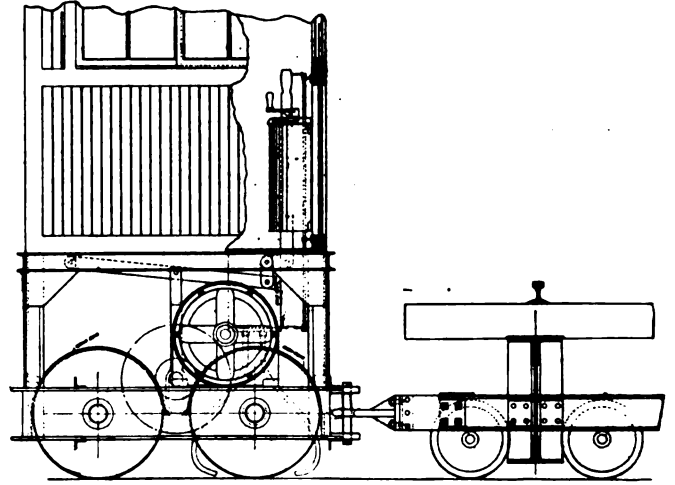

Fig. 3—Turntable in Its Lowest Position Relative to the Tractor.

when the locomotive passes to the tractor end of the table. It will be noticed that whatever the position of the table, the tractor remains stationary.

Fig. 4 shows the machine with the housing removed and part of the cab cut away. This view shows the location of the tractor wheels, gearing, sanding device, brake lever, motor, etc. The cab is furnished with sliding windows and is 4 ft. 6 in. x 5 ft. 6 in., providing abundant room for the operator after the installation of the apparatus. The traction wheels are 30 in. double



Fig. 4—Arrangement of Apparatus on Turntable Tractor.

plate, with flat chilled treads, and each is furnished with a steel driving gear, securely bolted to a faced shoulder on the inside of the wheel; all the gears and pinions are steel, carefully machined and are accurately cut. The electrical equipment may be furnished according to the railroad company's specification.

Steel band brakes, controlled by a hand lever in the cab, are applied to each of the wheels and have a positive action, avoiding the danger of stripping the gears as may be the case when brakes are applied to a drum on the motor or intermediate shafts. The positive action of the brake removes the temptation or the necessity on the part of the operator to reverse the motor in order to stop at a given point, thereby materially reducing maintenance charges on the electrical equipment.

The sanding device consists of a cast iron hopper which is tapered to the bottom and contains about  $1\frac{1}{2}$  cu. ft. of sand; it is furnished with a cast iron cap set level with the floor of the cab and the hopper can be filled from the inside of the cab, so

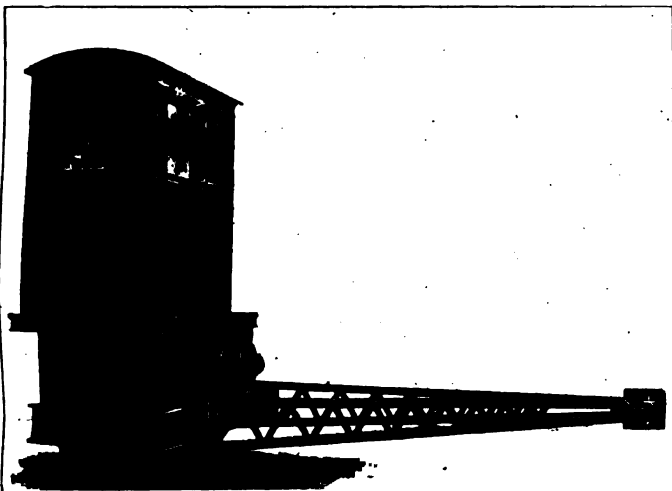

Fig. 5—Turntable Tractor.

that there is no opportunity for the sand to get wet; the plug valve in the bottom of the hopper is controlled by a lever in the cab.

The frame, which carries all the equipment, is of a heavy design and is cast in one piece; a structural steel frame, on which the cab rests, is riveted to it. The sliding link which connects the tractor to the table is fastened to this frame. As shown in Fig. 5, this frame is supplemented by a structural steel A-shaped frame which extends toward the center of the table and is also connected to the girder by a sliding link. The motor and all the working parts are enclosed by sheet steel plates in which are provided doors of ample size; all the working parts are thus easily accessible for inspection and repairs.

**INDIAN PASSENGER TRAFFIC IN 1912.**—The number of passengers carried on the railways of India in 1912 reached a total of 417,230,000; against 389,860,000 in 1911, while the earnings therefrom increased from \$61,636,000 to \$65,216,000. As usual, far the greater part of the passenger revenue came from the third-class, 375,566,800 passengers in this class having produced earnings of \$56,711,665, showing an improvement of 27,090,000 in numbers and of \$4,273,330 in receipts. First-class traffic, which, with one or two exceptions, produces no profit to Indian railways, reached the comparatively insignificant total of 795,500 in numbers and \$2,096,665 in receipts. At the same time this is an improvement on every previous year except 1911, when the Coronation Durbar traffic made a special increase in first-class earnings. The Great Indian Peninsula, the East Indian and the North Western State Railway had the largest share in this traffic in 1912.

## General News.

A telephone circuit for despatching is being put up by the Denver & Rio Grande between Grand Junction, Col., and Ogden, Utah, 328 miles. The cost will be about \$50,000. "Blind" sidings will be equipped with telephone boxes, and all trains will carry instruments.

Illinois Central southbound passenger train No. 1 was held up near Batesville, Miss., early on July 4, by two men who boarded the train just south of Batesville, cut the express, baggage and mail cars from the train and ran them ahead about 5 miles. They dynamited the express safe and are said to have obtained a large sum of money. After blowing the safe the men ran the engine to Pope, about 3 miles farther, and abandoned it.

The Chicago city council committee on railway terminals on July 7 unanimously endorsed the appointment of John F. Wallace as engineering expert to make a report to the committee and act as its adviser on the subject of proposed railway terminal locations in Chicago. The selection of Mr. Wallace, as announced last week, was made by a subcommittee, and an effort was made by some members at the meeting on Monday to employ a committee of three or five experts instead of one. Such a plan was proposed in resolutions submitted by the City Club to the committee, but after discussion it was voted down.

The Southern Pacific Company is saving \$1,000 a month by using old boiler tubes. These will no longer be sold as junk, but will be pieced together at the shops and used for piping water and air about the yards of the company. H. C. Pearce, general storekeeper, has returned from Los Angeles, where this experiment in salvage was tried out, and says that about \$12,000 has been saved in the last year by this new economy. The tubes will be gathered together at all roundhouses and shops, shipped to the general stores, cleaned, turned for screw connections and then redistributed for pipe purposes instead of new material.

Beginning on August 1, all passenger trains of the Chicago & Eastern Illinois running to and from Chicago will arrive at and depart from the Dearborn station, instead of the LaSalle street station, using the tracks of the Chicago & Western Indiana. The Chicago & Eastern Illinois is one of the five roads that own the stock of the Western Indiana, but for several years its trains have used the LaSalle street station of the Chicago, Rock Island & Pacific and Lake Shore & Michigan Southern roads. In order to provide for passengers who go to the LaSalle street station by mistake, omnibuses will be run to take them free of charge to the Dearborn station.

In preparation for greater fruit crops, the Pacific Fruit Express is building a large new ice manufacturing plant at Los Angeles. It will be completed in October, will have a capacity of 85 tons daily, and will cost \$125,000. The design is such that, by the installation of another unit of machinery, the capacity can be increased to 170 tons daily. Storage room will be provided for 15,000 tons. The building will be of concrete construction. Icing platforms will care for 20 cars at one time, so that fruit can be moved promptly without delay in refrigeration. The ammonia condensers will be of a new type. The entire output is to be used for the rapidly increasing refrigerated shipments of fruit through Southern California and in icing Southern Pacific passenger cars at the Los Angeles station.

The educational bureau of the Union Pacific, the Illinois Central and the Central of Georgia, which has heretofore carried on several correspondence courses for the employees of these roads, besides conducting the educational features of the shop apprentice system, has been reorganized so that now the correspondence courses are handled by the educational bureau as a separate organization; a nominal charge of \$1 per month being made to employees desiring to participate in the correspondence courses. In the work of the bureau the above named roads will cooperate, and it will continue the same as before except for the small charge for instruction. D. C. Buell, chief of the educational bureau, will continue to be in charge and will be located at Omaha, Neb. The apprentice schools of these roads will continue as before the reorganization.

F. R. Anderson, of the Northern Pacific, speaking at the convention of the train despatchers at Los Angeles, on the advan-

tages of the telephone in train despatching, said that a train order of 35 or 40 words could be sent to four offices, and the repetitions received back, in from 3 minutes 20 seconds to 4 minutes, this including the time consumed in calling the offices. Speaking of emergencies, he said that not long ago a bridge, on the Northern Pacific, was carried out by an ice jam which formed very quickly. Repairers at work on the track discovered the break in the road, but they were on the opposite side of the stream from that on which a passenger train was approaching; but going a short distance to a telephone booth, the foreman was able to notify the despatcher of the trouble and this message was perhaps the means of saving the passenger train from going into the river. [This incident suggests that, where practicable, telephone and telegraph wires should be carried across rivers independently of the bridge which carries the tracks.]

The New York, New Haven & Hartford announces that its offer of \$10,000 for the best automatic stop has expired; and that 2,816 persons have entered the competition. Only 704 of the applicants have submitted plans; but any inventor who got his name on the list before July 1 will be allowed until January 1, 1916, to qualify. C. H. Morrison, signal engineer of the road, up to July 1 had written 4,062 letters; and 1,483 copies of patents had been obtained from the Patent Office. Of the 704 devices of which plans have been submitted not one has met condition No. 1, which reads: "The apparatus should be so constructed that the removal or failure of any essential part would cause the display of a stop signal and the application of the train brakes, and if electric circuits are employed, they should be so designed that the occurrence of a break, cross, or ground, or a failure of the source of energy in any of the circuits, should cause the display of a stop signal and the application of the train brakes." A few of the devices submitted might be made to meet this requirement. The company will proceed at once to test two devices on the western division, between Hartford and Newington. One of these is the invention of Mr. Webb, of the International Signal Company, and the other of an engineer of the Union Switch & Signal Company.

**Chicago Terminal Plans.**

Jarvis Hunt, the architect who has been urging plans for a central railway passenger terminal at Twelfth street, Chicago, has now submitted details of an additional feature of this proposed plan to provide for a loop around the business section of the city for suburban traffic. The proposed loop would be in a subway running north from the union station between Canal street and the Chicago river, straightened as provided in his original plan, to Indiana street; then east to Michigan boulevard and south along Grant Park or Michigan boulevard to Sixteenth street; thence west to Canal street. As this loop connects with the main station it would connect all suburban service with all through service; and provision is made for ten suburban stations located at convenient points around the loop.

The Union Station Company has published another full-page advertisement in the Chicago papers headed "Union Labor Endorses West Side Terminal," and quoting the resolutions adopted by the Chicago Building Trades Council endorsing the plan for the terminal station proposed by the roads now using the old union station between Jackson boulevard, Clinton street, Adams street and the Chicago river, together with similar resolutions passed by the Chicago Federation of Labor. The advertisement states that the proposed new west side terminal "will be a \$40,000,000 improvement to Chicago, and will necessitate the employment of thousands of workmen. Just as soon as the present plans for its construction are approved by the mayor and the city council work will commence."

**Don'ts for Operators and Others on Railroad Telephone Lines.**

Don't depend upon a high partition to separate one train despatcher from another; each should have a separate room; freedom from unnecessary noise is the first element of successful operation.

Don't fix station telephones to tables on which are telegraph instruments.

Don't allow any person—even the trainmaster—to usurp the despatcher's authority on the despatching circuit. Everything

except despatching should come on the wire by one of two courses, either through the despatcher's office or through application made to him by a station operator.

Don't use the despatching circuit unnecessarily for other business; the despatcher, with the receiving apparatus constantly at his ear, must listen to everything that goes over the wire; outside matters tend to distract him.

Don't criticize the despatcher, on the despatching wire, within hearing of the operators. (This is addressed to the trainmasters.)

Don't work under the disadvantages incident to induced currents and other imperfections; these can be done away with if proper effort is directed to that end.

[From a paper on Abuses of the Train Wire, by Hugh McPhee, superintendent of the Western Union Telegraph Company at Los Angeles, Cal., read before the Train Despatchers' annual convention.]

**Automobile Accidents at Railroad Crossings Comparatively Few.**

The bureau of news of the Southern Pacific has prepared a statement showing the very small proportion of automobile accidents that occur at railroad grade crossings, as shown by figures that have been compiled recently. In all the states of the Union, for a period from April 1 to May 23 of this year, out of 1,623 auto accidents, only about 1½ per cent., or 25, occurred where wagon roads cross a railroad track. The rest were away from the railroads. The statistics for the Pacific coast are:

	Number of Accidents.	Fatalities.	Serious Injuries.	Minor Injuries.	Total.
<i>California—</i>					
Escondido .....	3	1	2	0	3
Fresno .....	4	1	1	1	3
Long Beach ....	3	0	0	2	2
Los Angeles ....	29	10	12	47	69
Oakland .....	5	0	2	4	6
Oxnard .....	1	0	0	2	2
Pasadena .....	1	0	0	2	2
Sacramento .....	6	1	4	1	6
San Diego .....	8	0	1	5	6
San Francisco...	31	10	22	17	49
San Jose .....	9	2	1	4	7
Santa Cruz .....	1	0	0	1	1
Stockton .....	3	2	1	0	3
<i>Nevada—None.</i>					
<i>Oregon—</i>					
Portland .....	13	4	5	7	16
<i>Washington—</i>					
Seattle .....	13	1	5	17	23
Spokane .....	7	0	0	7	7
Tacoma .....	1	0	0	0	0
<i>All States .....</i>	<i>1,623</i>	<i>269</i>	<i>431</i>	<i>1,164</i>	<i>1,864</i>

The only railroad grade crossing accidents with automobiles on the Pacific coast were:

	Number of Accidents.	Fatalities.	Serious Injuries.	Minor Injuries.	Total.
<i>California—</i>					
Fresno .....	1	0	0	1	1
San Francisco...	1	1	1	0	2

**Merits and Demerits.**

Honor-roll items and other paragraphs showing how railway employees are recognized by their superintendents when their conduct is exceptionally good, have been published in the *Railway Age Gazette* at numerous times during the past few years. Commenting on our editorial on this subject, printed in the issue of June 20, a correspondent suggests that both sides of the matter ought to be brought out; that exceptionally bad as well as exceptionally good conduct ought to be made generally known. Responding to this suggestion we print below the demerits and demerits on a division of the Rock Island road for two months. This is only a summary; it does not show the proportionate amount of inefficiency, for the total number of men employed, which would have to be known if proportions were to be calculated, is not given. Neither can the magnitude of the punishment nor the seriousness of the offense be estimated, except in a rough way. Each paragraph might be amplified to a half column, if it were desired to teach the lesson of the particular cases referred to. Some amplification is necessary, of course, if cases of this kind are used for the purpose of admonishing other employees. Indeed, it is often well to name the dates and the places, so that employees can fix the lessons in their minds in concrete form.

These paragraphs cover a period of two months ending May 31, 1913, and are as follows:

Two switchmen, two truckmen and an operator have been dismissed for violation of Rule G (relative to intoxicating liquors).

A passenger brakeman, a stower, a janitor and window washer have been dismissed on account of services not being satisfactory.

Two passenger brakemen have been dismissed for assignment of wages.

A passenger brakeman has been dismissed for absenting himself without permission.

Three switchmen have been dismissed for failure to report for work.

A helper has been dismissed for negligence in the performance of his duties.

A coal unloader has been dismissed on account of reaching the age limit.

A switchman has been dismissed for deserting his crew.

Four engineers, two firemen, one switchman, one passenger conductor and one passenger brakeman have each been assessed thirty demerit marks for being responsible for accidents.

A fireman has been assessed fifteen demerit marks for deserting engine in station, which resulted in delay to train.

Two engineers have each been assessed fifteen demerit marks for being responsible for accidents.

Two engineers have each been assessed thirty demerit marks for running between stations and trains.

An engineer and a passenger brakeman have each been assessed thirty demerit marks for disregarding signals.

A passenger brakeman has been assessed ten demerit marks for failure to protect his train.

A switchman has been assessed ten demerit marks for handling a loaded car as an empty, resulting in delay to same.

An engineer and a switchtender have each been assessed thirty demerit marks for being equally responsible for passenger train running through switch.

Two switchmen have each been assessed five demerit marks for being responsible for accidents.

Four switchmen and an engineer have each been assessed ten demerit marks for being responsible for accidents.

An engineer has been reprimanded for being responsible for accident.

Three passenger brakemen have each been assessed five demerit marks for not obeying instructions relative to playing cards.

Three engineers and two firemen have been reprimanded for violation of city smoke ordinance.

Four engineers and five firemen have each been assessed five demerit marks for violation of city smoke ordinance.

A fireman has been assessed ten demerit marks for violation of city smoke ordinance.

Two engineers and a switchman have each been assessed five demerit marks for being responsible for switches being run through.

#### A Medical Inspection Bureau for Employees.

The Brooklyn Rapid Transit Company, operating street surface and elevated railroads in Brooklyn, N. Y., has made permanent the medical inspection bureau which was started last December, for the purpose of providing free medical attendance to the operating employees and compulsory medical inspection preliminary to sick excuse. This bureau has made a record in the past six months in the reduction of the sick list which amply justifies the decision to make medical inspection a permanent feature. This idea grew out of an investigation by President T. S. Williams in 1911, when it appeared that material variations existed between the different terminals of the B. R. T. in the treatment of sick excuses. There had grown up a custom whereby it was considered the usual thing for men to report sick when in fact they wanted time off for purposes of recreation, and from this evasion of the letter of the law a tendency was observed to justify other evasions of operating requirements. The medical inspection bureau is based on the following propositions:

First. If a man is sick, it is contrary to the interests of the company, as well as the man, that he should be required to work.

Second. The proper individual to determine a condition of sickness or health is not an operating officer but a physician.

Third. When a man is excused on account of illness, it is quite as important that his recovery for work should be certified, as his original sick excuse.

Fourth. A proper amount of time off should be allowed for recreation, but recreative excuses should be granted as such, and not under guise of sick excuses.

There is a benefit association whose members had received (when they asked for it) free medical attendance from the association's physician, but since December 20, 1912, the medical inspection bureau has been in operation. Dr. H. H. Stearns, chief physician of the Employees' Benefit Association, was placed in charge of the bureau. When a man reports sick at his terminal, he is given an excuse card which entitles him to go to the nearest examination office at the next office hour to have his ailment diagnosed. The doctor at the inspection office examines him and either excuses him indefinitely, excuses him for a limited period, as in the cases of minor ailments, or in the event that it appears that the man is feigning illness, orders him to report back to his terminal, where discipline is administered. In case a man is excused indefinitely, he receives treatment during his illness at home or at the doctor's office, as the case may be, and upon recovery, receives a certificate saying when he is required to report back for work. In case a man reports ill from his house a doctor calls within six hours. The system has worked almost without a hitch, to the accomplishment of a very substantial reduction in the days of work lost on account of illness. In the first half of 1912 the aggregate sick list represented the loss of 44,459 days' work among approximately 9,000 employees, whereas in the six months ended June 30, 1913, the aggregate time lost on account of sickness was 34,148 days' work—a gain of 10,311 days' work, or 23 per cent.

The observation of the physicians in charge indicates that the gain is in a reduction of the time lost by men who are sick; in other words, a shortening of the period of illness. Under the old system a man contracting a minor ailment would work along with it until his case became aggravated, and then be absent for a week or more, whereas under the new conditions, men are coming more and more gladly to welcome the opportunity to receive treatment at the inception of illness, and return to work in 24 or 48 hours. An increasing number of men also are coming to the medical offices for treatment while on duty, and it is the policy of the company to be prepared at these offices to dispense directly simple remedies for such cases.

#### A Railroad Officer Very "High Up."

Charles S. Mellen, president of the New York, New Haven & Hartford, appeared before Coroner Phelan at Bridgeport, Conn., July 7 to testify concerning the Stamford collision but, after a long discussion, was excused from answering questions on the ground that he was an indicted defendant awaiting trial on charges of manslaughter growing out of the wreck at Westport, and that his answers might tend to incriminate himself or other officers also indicted. Questioned about Vice-President Whaley's authority, Mr. Mellen said:

"I would be glad to answer that if I were a free man, not under indictment. I have got to undergo trial, I think very unjustly. It was not because there was any thought that I was guilty that I was indicted, but it was done to coerce others into changing the line of their defense. I do not understand all these technical objections set up by counsel. I would like to talk frankly and freely as a layman, but I am yoked up with others in my indictment. If I answer the question about authority over tracks and trackage, may it not be—I am arguing as a layman—that I will incriminate those with whom I am yoked up, and so indirectly incriminate myself?"

From the report of the hearing we make the following extracts:

Mr. Mellen entered the court room at twenty-five minutes to three o'clock, and took a seat two chairs away from Charles J. Doherty, driver of the locomotive. Mr. Mellen wore a blue serge suit, a polka dot bow tie, black shoes and a very low collar. The clearness of his blue eyes was remarked upon.

"You are the president of the New York, New Haven & Hartford Railroad?" asked the coroner.

Mr. Mellen answered in the affirmative.

"Are your powers and duties prescribed by written rules?"

"I think not," said the witness. "I haven't seen any."

"Are there any oral rules in this regard?"

"Not that I am aware of. . . . In any matter the board of

directors seeks to take charge of it is supreme. The president can do nothing that the board of directors can't overrule."

"Mr. Mellen, how do you know your powers and limitations of powers, and how are you guided in determining things beyond your powers?"

"By experience and common sense and advice of counsel."

Asked about the powers and duties of the president and vice-presidents and how they were prescribed, Mr. Mellen declared that this was done by general custom.

"Are there any written rules concerning the duties of the vice-presidents?"

"Nothing, unless it is contained in the circular notice of their appointment. In railroad circles there is a well defined line of demarkation in this respect which is not specified in the notice or by any order of the president."

"How many vice-presidents are there in your company?"

"I think there are six, but I wouldn't be too sure; there may be seven and may be five."

"I'm a layman," said Mr. Mellen, "and I don't know the meaning of all these finely drawn points. I came here to testify at the advice of counsel. I am under arrest and am to be tried in September in connection with the Westport wreck. I have been told not to answer questions concerning my duties or the duties of others linked with me in the indictment. For my own part I don't see any reason for not answering certain questions, but as a layman I do feel that I should continue to trust my interests to my counsel. If not then I had better discharge my counsel."

"Who is the general superintendent?"

"Mr. Woodward, I think," said the witness.

"Do you know the scope of his duties?"

"I do not. He is a subordinate officer of Mr. Whaley. I do not come into contact with him, and do not think that I should know him if he came into this room. I don't recall that I have ever met him. The vice-president defines his duties."

"You have cause to regret not knowing Mr. Woodward, as he's a very fine gentleman."

"He might be," said Mr. Mellen. "We have thousands of them on the road, but I can't get to know them all."

"Is your division superintendent Mr. Droege?"

"I think so."

The witness said that the last named official reported to Mr. Woodward. Mr. Mellen said:

"He reports to the general superintendent. So far as the management of the railroad itself is concerned Mr. Whaley is head of all the people, general manager and general superintendent."

"Who is the superior of Mr. Morrison, the signal engineer?"

"Mr. Whaley. He hires him or he fires him, just as he chooses."

"I hope he won't want to fire Mr. Morrison, for he's a very fine gentleman."

"I hope he won't unless he deserves it," said Mr. Mellen.

"Who is it that has charge of the minutes of the board of directors?"

"The secretary."

"Are you above him in that regard?"

"I have no authority over him, as he is an officer of the board. I have no authority about that without the consent of the board of directors."

#### The Conductors' and Brakemen's Demands.

The committees of the conductors' and the brakemen's brotherhoods met in New York City this week and counted the votes of the members of those organizations on the question of authorizing the officers to strike, if deemed necessary, for higher wages on the eastern railroads; and on Tuesday they had a conference with the committee, Elisha Lee, chairman, representing the railroads. The vote was overwhelmingly in favor of a strike, the figures as given out being as follows: Conductors, in favor of strike, 11,808; against strike, 1,466; brakemen, in favor, 60,829; against, 1,631. The managers' committee refused to grant any increase in wages whatever; and the leaders of the brotherhood have called together the whole of their joint committee, numbering about one thousand men, to meet in New York City this week, Saturday, to decide whether or not to strike.

Speaking to a reporter, Mr. Garretson, chief of the conductors,

said that as the railroads had refused to arbitrate under the Erdman act, the brotherhoods would not appeal to the Washington authorities.

Of the total of 76,683 votes, 72,473 were in favor of striking if the roads refused to meet the men's demands and 4,210 were opposed to a strike. Eighty-nine per cent. of the voting conductors voted in favor of a strike and 98 per cent. of the brakemen. The votes on some of the principal railroads were as follows:

Railroad.	Conductors.		Brakemen.	
	For.	Against.	For.	Against.
Boston & Albany.....	168	19	911	25
Boston & Maine.....	545	82	3,106	97
Baltimore & Ohio.....	1,193	43	6,403	54
Central of New Jersey.....	174	115	1,101	51
Cincinnati, Hamilton & Dayton....	142	6	656	3
Cleveland, Cincinnati, Chicago & St. Louis.....	553	31	1,814	4
Delaware & Hudson.....	224	12	1,151	5
Delaware, Lackawanna & Western..	327	28	1,324	21
Erie.....	532	115	3,322	23
Lake Shore & Michigan Southern..	372	69	1,953	37
Long Island.....	157	5	650	4
Michigan Central.....	372	30	1,181	19
New York Central & Hudson River	888	127	4,596	48
New York, New Haven & Hartford	613	46	3,093	65
Pennsylvania—East of Pittsburgh..	1,585	350	12,632	824
Pennsylvania—West of Pittsburgh..	1,379	147	5,646	96
Philadelphia & Reading.....	685	87	3,244	103

Elisha Lee, chairman, last week published a circular, in which he said:

"The conductors and trainmen of the eastern railroads received increases of \$30,000,000 per annum in 1910, according to President Lee, of the Trainmen's brotherhood. As the wages of these employees now approximate some \$85,000,000 in a year, their total wages prior to the 1910 increase must have been \$55,000,000 or \$60,000,000. It appears, therefore, from President Lee's own estimate, that the trainmen and conductors in 1910 received an annual increase in wages of 50 per cent. Yet in spite of this, they are now asking for \$17,000,000, or 20 per cent. per annum additional. If the roads granted the increase now asked by the trainmen and conductors, it would mean that in three years increases in pay to employees in train service would amount to \$52,000,000 per annum, which is equivalent to placing on these properties a lien of \$1,040,000,000 of 5 per cent. securities having preference over first mortgage bonds. The conductors and trainmen in the eastern territory have practically uniform wages and working conditions, which are all-sufficient and exceedingly liberal. These conditions and wages were fixed by E. E. Clark, former president of the Order of Railway Conductors, and P. H. Morrissey, former president of the Brotherhood of Railroad Trainmen, who acted as arbitrators in the New York Central controversy in 1910. The very large increased cost to the eastern railroads of the increases in pay granted to the conductors and trainmen in 1910 as a result of the Clark-Morrissey award, is admitted by President Lee of the Brotherhood of Railroad Trainmen, who, in his report at the tenth biennial convention of that organization, estimated the increases in pay received by conductors, trainmen and yardmen in the East as a result of the brotherhood's activities as about \$30,000,000 per annum."

On Monday of this week the Erie formally withdrew from the railroad conference committee. J. C. Stuart, vice-president, writing to Elisha Lee, said:

"Similar proceedings have in the past resulted in increased wages and, while it may be possible for some roads to meet these increases, the Erie is not in a position to do so at present. The wage increase demanded of it amounts to an increase of 25 per cent., or a total annual cost on the basis of the present business of approximately \$1,200,000. To offset this increase without disturbing the net earnings (on basis of 1912) it would be necessary to increase the force and handle an additional volume of traffic, representing a gross annual increase of \$4,377,195.

"The employees making the present demands are the best paid, as a class, of any on the Erie Railroad. They received a substantial increase in 1910. It was followed by similar demands on the part of other railroad employees. The orbit has been completed, and the present demand is the beginning of a new cycle. It has frankly been stated that if the conductors and trainmen receive the increase asked for, all the other organizations will promptly follow.

"A passenger conductor who has a regular run between Jersey City and Buffalo receives \$213.70 per month, while under

the proposed arrangement he will receive \$258.22 a month, or an increase of 20.8 per cent.

"A passenger brakeman running on the same train now receives \$121.98 for twenty-one days' service per month, and under the new arrangement will receive \$154.96, or an increase of 27 per cent., with no increased duties.

"The New York state law, effective September 1, 1913, stipulates that an additional brakeman, known as a 'full crew' brakeman, for whom the railroad officers can find no occupation, must be placed on certain trains. His rate will be the same as the brakemen cited; so that the present wage demand contemplates an increase of 27 per cent. to a 'full crew' brakeman who has not yet been placed in service, or whose real value has never been developed.

"While this company is willing to consider the wages or conditions of individuals, it will not agree to a general increase to any class of employees until safety appliances, such as block signals, steel cars and greater facilities, have been provided and the net earnings justify further wage increases. If this demand and those which will follow are to be conceded as they have been in the past, the officials of the Erie company, who are held responsible both by the public and the owners, cannot be expected to join in its spoliation; therefore, we have to decline a further participation in the proceedings under the present conditions."

The arbitration bill recently introduced in Congress has passed the Senate and is now in the hands of a House Committee, with certain changes proposed by Secretary Wilson of the Department of Labor. The Senate or "Newlands Bill" provides for an independent bureau of mediation, with a chief mediator at a salary of \$7,500, appointed for a term of seven years. This the railroads and brotherhoods contend is necessary to remove the office from any possible political bias and, at the same time, provide for the appointment of a man whose whole time shall be devoted to this work and whose qualifications for this particular kind of work shall alone be considered by the President in making the appointment; whereas, under the present law, the conciliators are men whose principal work is not industrial mediation but something else. Secretary Wilson's contention is that, as the conciliation feature of the Erdman act has worked well heretofore, it should remain as it is, but that the other amendments urged by the railroads and the brotherhoods should be made.

MEETINGS AND CONVENTIONS.

The following list gives names of secretaries, dates of next or regular meetings, and places of meeting.

- AIR BRAKE ASSOCIATION.—F. M. Nellis, 53 State St., Boston, Mass.
- AMERICAN ASSOCIATION OF DEMURRAGE OFFICERS.—A. G. Thomson, Boston, Mass. Convention, May 19, 1914, St. Louis.
- AMERICAN ASSOCIATION OF GENERAL PASSENGER AND TICKET AGENTS.—W. C. Hope, New York. Annual meeting, October 14-15, Philadelphia, Pa.
- AMERICAN ASSOCIATION OF FREIGHT AGENTS.—R. O. Wells, East St. Louis, Ill.
- AMERICAN ASSOCIATION OF RAILROAD SUPERINTENDENTS.—E. H. Harman, St. Louis, Mo.; 3d Friday of March and September.
- AMERICAN ELECTRIC RAILWAY ASSOCIATION.—H. C. Donecker, 29 W. 39th St., New York.
- AMERICAN ELECTRIC RAILWAY MANUFACTURERS' ASSOC.—H. G. McConaughy, 165 Broadway, New York. Meetings with Am. Elec. Ry. Assoc.
- AMERICAN RAILWAY ASSOCIATION.—W. F. Allen, 75 Church St., New York. Next meeting, November 19, 1913, Chicago.
- AMERICAN RAILWAY BRIDGE AND BUILDING ASSOCIATION.—C. A. Lichty, C. & N. W., Chicago. Convention, October 21-24, 1913, Montreal.
- AMERICAN RAILWAY ENGINEERING ASSOCIATION.—E. H. Fritch, 900 S. Michigan Ave., Chicago.
- AMERICAN RAILWAY MASTER MECHANICS' ASSOCIATION.—J. W. Taylor, Old Colony building, Chicago.
- AMERICAN RAILWAY TOOL FOREMEN'S ASSOCIATION.—A. R. Davis, Central of Georgia, Macon, Ga. Next convention, July 22-24, Chicago.
- AMERICAN SOCIETY FOR TESTING MATERIALS.—Prof. E. Marburg, University of Pennsylvania, Philadelphia, Pa.
- AMERICAN SOCIETY OF CIVIL ENGINEERS.—C. W. Hunt, 220 W. 57th St., New York; 1st and 3d Wed., except June and August, New York.
- AMERICAN SOCIETY OF ENGINEERING CONTRACTORS.—J. R. Wenlinger, 11 Broadway, New York; 2d Tuesday of each month, New York.
- AMERICAN SOCIETY OF MECHANICAL ENGINEERS.—Calvin W. Rice, 29 W. 39th St., New York.
- AMERICAN WOOD PRESERVERS' ASSOCIATION.—F. J. Angier, B. & O., Baltimore, Md. Next convention, January 20-22, 1914, New Orleans, La.
- ASSOCIATION OF AMERICAN RAILWAY ACCOUNTING OFFICERS.—C. G. Phillips, 143 Dearborn St., Chicago. Annual meeting, May 28, Atlantic City, N. J.
- ASSOCIATION OF RAILWAY CLAIM AGENTS.—J. R. McSherry, C. & E. I., Chicago.
- ASSOCIATION OF RAILWAY ELECTRICAL ENGINEERS.—Jos. A. Andreucetti, C. & N. W. Ry., Chicago. Annual convention, October 18-24, Chicago.
- ASSOCIATION OF RAILWAY TELEGRAPH SUPERINTENDENTS.—P. W. Drew, 112 West Adams St., Chicago.
- ASSOCIATION OF TRANSPORTATION AND CAR ACCOUNTING OFFICERS.—G. P. Conard, 75 Church St., New York.

- ASSOCIATION OF WATER LINE ACCOUNTING OFFICERS.—W. R. Evans, Chamber of Commerce, Buffalo, N. Y. Annual meeting, October 8, Philadelphia, Pa.
- BRIDGE AND BUILDING SUPPLY MEN'S ASSOCIATION.—H. A. Neally, Joseph Dixon Crucible Co., Jersey City, N. J. Meeting with American Railway Bridge and Building Association.
- CANADIAN RAILWAY CLUB.—James Powell, Grand Trunk Ry., Montreal, Que.; 2d Tuesday in month, except June, July and Aug., Montreal.
- CANADIAN SOCIETY OF CIVIL ENGINEERS.—Clement H. McLeod, 413 Dorchester St., Montreal, Que.; Thursday, Montreal.
- CAR FOREMEN'S ASSOCIATION OF CHICAGO.—Aaron Kline, 841 North 50th Court, Chicago; 2d Monday in month, Chicago.
- CENTRAL RAILWAY CLUB.—H. D. Vought, 95 Liberty St., New York; 2d Thurs. in Jan. and 2d Fri. in March, May, Sept., Nov., Buffalo, N. Y.
- CIVIL ENGINEERS' SOCIETY OF ST. PAUL.—L. S. Pomeroy, Old State Capitol building, St. Paul, Minn.; 2d Monday, except June, July, August and September, St. Paul.
- ENGINEERS' SOCIETY OF PENNSYLVANIA.—E. R. Dasher, Box 704, Harrisburg, Pa.; 1st Monday after 2d Saturday, Harrisburg, Pa.
- ENGINEERS' SOCIETY OF WESTERN PENNSYLVANIA.—E. K. Hiles, Oliver building, Pittsburgh; 1st and 3d Tuesday, Pittsburgh, Pa.
- FREIGHT CLAIM ASSOCIATION.—Warner P. Taylor, Richmond, Va.
- GENERAL SUPERINTENDENTS' ASSOCIATION OF CHICAGO.—E. S. Koller, 226 W. Adams St., Chicago; Wed., preceding 3d Thurs., Chicago.
- INTERNATIONAL RAILWAY CONGRESS.—Executive Committee, 11, rue de Louvain, Brussels, Belgium. Convention, 1915, Berlin.
- INTERNATIONAL RAILWAY FUEL ASSOCIATION.—C. G. Hall, 922 McCormick building, Chicago.
- INTERNATIONAL RAILWAY GENERAL FOREMEN'S ASSOCIATION.—Wm. Hall, 829 West Broadway, Winona, Minn. Next convention, July 15-18, Chicago.
- INTERNATIONAL RAILROAD MASTER BLACKSMITHS' ASSOCIATION.—A. L. Woodworth, Lima, Ohio. Annual meeting, August 18, Richmond, Va.
- MAINTENANCE OF WAY & MASTER PAINTERS' ASSOCIATION OF THE UNITED STATES AND CANADA.—W. G. Wilson, Lehigh Valley, Easton, Pa.
- MASTER BOILER MAKERS' ASSOCIATION.—Harry D. Vought, 95 Liberty St., New York.
- MASTER CAR BUILDERS' ASSOCIATION.—J. W. Taylor, Old Colony building, Chicago.
- MASTER CAR AND LOCOMOTIVE PAINTERS' ASSOC. OF U. S. AND CANADA.—A. P. Dane, B. & M., Reading, Mass. Annual meeting, September 9-12, Ottawa, Can.
- NATIONAL RAILWAY APPLIANCE ASSOC.—Bruce V. Crandall, 537 So. Dearborn St., Chicago. Meetings with Am. Ry. Eng. Assoc.
- NEW ENGLAND RAILROAD CLUB.—W. E. Cade, Jr., 683 Atlantic Ave., Boston, Mass.; 2d Tuesday in month, except June, July, Aug. and Sept., Boston.
- NEW YORK RAILROAD CLUB.—H. D. Vought, 95 Liberty St., New York; 3d Friday in month, except June, July and August, New York.
- NORTHERN RAILROAD CLUB.—C. L. Kennedy, C. & M. & St. P., Duluth, Minn.; 4th Saturday, Duluth.
- PEORIA ASSOCIATION OF RAILROAD OFFICERS.—M. W. Rotchford, Union Station, Peoria; 2d Thursday.
- RAILROAD CLUB OF KANSAS CITY.—C. Manlove, 1008 Walnut St., Kansas City, Mo.; 3d Friday in month, Kansas City.
- RAILWAY BUSINESS ASSOCIATION.—Frank W. Naxon, 2 Rector St., New York. Annual dinner, second week in December, 1913, New York.
- RAILWAY CLUB OF PITTSBURGH.—J. B. Anderson, Penna. R. R., Pittsburgh, Pa.; 4th Friday in month, except June, July and August, Pittsburgh.
- RAILWAY ELECTRICAL SUPPLY MANUFACTURERS' ASSOC.—J. Scribner, 1021 Monadnock Block, Chicago. Meetings with Assoc. Ry. Elec. Engrs.
- RAILWAY GARDENING ASSOCIATION.—J. S. Butterfield, Lee's Summit, Mo. Next meeting, August 12-15, Nashville, Tenn.
- RAILWAY DEVELOPMENT ASSOCIATION.—W. Nicholson, Kansas City Southern, Kansas City, Mo.
- RAILWAY SIGNAL ASSOCIATION.—C. C. Rosenberg, Bethlehem, Pa. Convention, October 14, Nashville, Tenn.
- RAILWAY STOREKEEPERS' ASSOCIATION.—J. P. Murphy, Box C, Collinwood, Ohio.
- RAILWAY SUPPLY MANUFACTURERS' ASSOC.—J. D. Conway, 2135 Oliver bldg., Pittsburgh, Pa. Meetings with M. M. and M. C. B. Assocs.
- RAILWAY TEL. AND TEL. APPLIANCE ASSOC.—W. E. Harkness, 284 Pearl St., New York. Meetings with Assoc. of Ry. Teleg. Sups.
- RICHMOND RAILROAD CLUB.—F. O. Robinson, Richmond, Va.; 2d Monday except June, July and August.
- ROADMASTERS' AND MAINTENANCE OF WAY ASSOCIATION.—L. C. Ryan, C. & N. W., Sterling, Ill. Convention, September 8-12, 1913, Chicago.
- ST. LOUIS RAILWAY CLUB.—B. W. Frauchental, Union Station, St. Louis, Mo.; 2d Friday in month, except June, July and Aug., St. Louis.
- SIGNAL APPLIANCE ASSOCIATION.—F. W. Edmonds, 3868 Park Ave., New York. Meetings with annual convention Railway Signal Association.
- SOCIETY OF RAILWAY FINANCIAL OFFICERS.—C. Nyquist, La Salle St. Station, Chicago.
- SOUTHERN ASSOCIATION OF CAR SERVICE OFFICERS.—E. W. Sandwich, A. & W. P. Ry., Montgomery, Ala.
- SOUTHERN & SOUTHWESTERN RAILWAY CLUB.—A. J. Merrill, Grant bldg., Atlanta, Ga.; 3d Thurs., Jan., March, May, July, Sept., Nov., Atlanta.
- TOLEDO TRANSPORTATION CLUB.—J. G. Macomber, Woolson Spice Co., Toledo, Ohio; 1st Saturday, Toledo.
- TRACK SUPPLY ASSOCIATION.—W. C. Kidd, Ramapo Iron Works, Hillsburn, N. Y. Meeting with Roadmasters' and Maintenance of Way Association.
- TRAFFIC CLUB OF CHICAGO.—W. H. Wharton, La Salle Hotel, Chicago.
- TRAFFIC CLUB OF NEW YORK.—C. A. Swope, 290 Broadway, New York; last Tuesday in month, except June, July and August, New York.
- TRAFFIC CLUB OF PITTSBURGH.—D. L. Wells, Erie, Pittsburgh, Pa.; meetings monthly, Pittsburgh.
- TRAFFIC CLUB OF ST. LOUIS.—A. F. Versen, Mercantile Library building, St. Louis, Mo. Annual meeting in November. Noonday meetings October to May.
- TRAIN DESPATCHERS' ASSOCIATION OF AMERICA.—J. F. Mackie, 7042 Stewart Ave., Chicago.
- TRANSPORTATION CLUB OF BUFFALO.—J. M. Sells, Buffalo; first Saturday after first Wednesday.
- TRANSPORTATION CLUB OF DETROIT.—W. R. Hurley, L. S. & M. S., Detroit, Mich.; meetings monthly.
- TRAVELING ENGINEERS' ASSOCIATION.—W. O. Thompson, N. Y. C. & H. R., East Buffalo, N. Y. Annual meeting, August, 1913, Chicago.
- UTAH SOCIETY OF ENGINEERS.—R. B. Ketchum, University of Utah, Salt Lake City, Utah; 3d Friday of each month, except July and August.
- WESTERN CANADA RAILWAY CLUB.—W. H. Rosevear, P. O. Box 1707, Winnipeg, Man.; 2d Monday, except June, July and August, Winnipeg.
- WESTERN RAILWAY CLUB.—J. W. Taylor, Old Colony building, Chicago; 3d Tuesday of each month, except June, July and August.
- WESTERN SOCIETY OF ENGINEERS.—J. H. Warder, 1735 Monadnock Block, Chicago; 1st Monday in month, except July and August, Chicago.



# Traffic News.

The two-cent passenger fare became effective on the principal Missouri lines on July 1. The freight rates fixed by the state law will go into effect on July 15.

The railways of Canada announce that free cartage of freight, which is, furnished by the railways at numerous towns in Canada, will on October 1 be abolished. The contractors who do this carting demand increased compensation, on the renewal of their contracts, and the railroad companies think it is time to abolish this expense.

The Texas Demurrage and Storage Bureau, with headquarters at Houston, went out of existence at the end of June, and all Texas railroads are to handle their demurrage accounts with their individual forces, except at Galveston, where the seven lines, whose terminals are at Galveston, Texas City and Port Bolivar, will continue to co-operate.

The Mississippi River & Bonne Terre has filed an application with the Missouri Public Utilities Commission for permission to retain the three-cent passenger fare, stating that a rate lower than three cents a mile would be confiscatory, as to that road. The company was not a party to the injunction suit against the state two-cent fare law.

The Oklahoma railways in agreeing to establish two-cent fares in the state during the first week in July, without awaiting the final settlement of the litigation of the state passenger fare and freight rate laws, have stipulated with the attorney general of the state that a trial on the merits of the case is not to be held before January 1, 1914, except upon agreement of both sides.

The special circular issued by F. A. Leland for the southwestern lines giving a price list for tariffs in accordance with the recent circular of the Interstate Commerce Commission, has been modified by supplement No. 1, which postpones the effective date from July 1 to October 1, in order to give the public additional time in which to advise of the numbers of tariffs desired to be kept on file after that date.

The number of freight cars moved over the Middle division of the Pennsylvania in the month of June was 217,301 as against 210,181 in the heaviest previous month, which was June, 1907. About half of these cars were loaded, and the average load was no doubt much heavier than in 1907 because of the abandonment of large numbers of small capacity cars during the past six years. The number of loaded cars passing Denholm during the month was 106,928 as compared with 99,606 in June, 1912.

Chairman Clark of the Interstate Commerce Commission held a meeting with officers of the Minnesota railways on July 1, and informed them that since the Minnesota rate case has been settled by the Supreme Court the commission will expect and require the roads to adjust their interstate rates so that they will not be higher than the combination of state or intermediate rates. The passenger officers of the Minnesota roads have announced that with the introduction of two-cent fares excursion rates will be abolished.

### Crop Conditions.

The Department of Agriculture estimates crop conditions to be as follows:

States.	Area, 1913. Preliminary Estimate.		Condition.			
	Per cent. compared with 1912.	Acres.	June 25, 1913.	May 25, 1913.	June 25, 1912.	10-yr. av.
Virginia .....	106	50,000	81	83	87	84
North Carolina .....	100	1,560,000	76	76	83	81
South Carolina .....	100	2,716,000	73	68	79	80
Georgia .....	99	5,336,000	74	69	72	81
Florida .....	94	230,000	85	83	76	85
Alabama .....	101	3,804,000	79	75	76	79
Mississippi .....	102	3,045,000	82	81	74	78
Louisiana .....	120	1,166,000	81	81	74	78
Texas .....	103	11,732,000	86	84	89	81
Arkansas .....	103	2,117,000	86	85	77	80
Tennessee .....	103	823,000	87	87	76	82
Missouri .....	106	113,000	88	90	75	82
Oklahoma .....	107	2,916,000	89	87	82	80
California .....	155	14,000	95	96	98	..
United States .....	102.5	35,622,000	81.8	79.1	80.4	80.2

### Traffic Club of New York.

The annual outing and clam bake of the Traffic Club of New York will be held at Witzel's Grove, College Point, Long Island, on July 19. The steamer *Adonis* has been chartered for the occasion and will leave the Central Railroad of New Jersey's pier No. 10, North river, at the foot of Cedar street at 10 a. m. No stops will be made on the going trip on the East river as formerly. There will be athletic events, including a baseball game between the representatives of the industrial and transportation interests, and arrangements have been made for a clay pigeon shoot which will be open to all. The clam bake will be served about 2:30 p. m., after which the steamer will proceed for a short sail up Long Island Sound, arriving at New York about 7 p. m.

### INTERSTATE COMMERCE COMMISSION.

The commission has further suspended from June 28 until December 27, certain tariffs, which contain advanced switching charges affecting all kinds of freight, in carloads, at Detroit, Mich.

The commission has suspended from June 28 until December 28, the schedules in certain tariffs, which provide for the discontinuance of free store-door delivery and pick-up service performed in connection with shipments of freight by the Baltimore & Ohio and the Pennsylvania Railroad at Washington, D. C.

The commission has further suspended until January 8, 1914, the schedules in 220 tariffs and supplements to tariffs filed by carriers operating in Central Freight Association territory, which would advance rates for the transportation of grain and grain products from points north of the Ohio river and east of the Mississippi river to interstate points.

The commission has further suspended from July 5 until January 5 the schedules in supplements to the tariff of the Chicago, Rock Island & Pacific, which proposed to cancel the through rates now in effect and applicable to the transportation of grain and grain products, c. l., from points in Chicago, St. Louis and Mississippi river rate territory to stations located on the Fort Smith & Western in Oklahoma.

The commission has suspended from July 1 until October 29, certain tariffs, which proposed to effect increases amounting to from 1 to 3 cents per 100 lbs. in commodity rates applicable to the transportation of kainit, hartsalz, muriate of potash, sulphate of potash, manure salts, double manure salts and sylvanite, c. l., from Baltimore, Md., and other eastern points to Cincinnati, Ohio, and other points in Central Freight Association territory.

The commission has further suspended from July 12 until January 12 the schedules in supplements to Agent L. A. Lowrey's tariff, which proposed by the suspended schedules to cancel the absorption by the Erie and certain other carriers entering Chicago of lighterage and floatage charges of 3 cents per 100 lbs. on carload and 5 cents per 100 lbs. on less than carload traffic handled by the Chicago River & Indiana lighterage and float service to and from points on the Chicago river front.

The commission has suspended from July 1 until October 29, the item of a supplement to Agent W. H. Hosmer's tariff, which proposed to cancel the application of third class rating for the transportation of stave, splint and stave rattan baskets, c. l., from points east of the Missouri river to certain points west thereof. The Western classification classifies baskets, c. l., second class, but, by an exception to said classification filed by carriers, third class rating is now applied on such traffic in this territory.

The commission has suspended until October 29, the schedules in certain tariffs which would increase rates on flaxseed originating beyond Minneapolis, Minn., and points taking Minneapolis rates to Fredonia, Kan., Kansas City and other Missouri river points. The present rate from Minneapolis to Fredonia is 15 cents per 100 lbs., and the proposed rate is 26½ cents per 100 lbs. The present rate to Kansas City is 10½ cents, and the proposed rate is 16½ cents per 100 lbs. Rates to the other points involved are similarly increased.

REVENUES AND EXPENSES OF RAILWAYS.

MONTH OF MAY, 1913.

Name of road.	Average mileage operated during period.	Operating revenues			Maintenance—			Operating expenses			Total.	Net operating revenue (or deficit).	Outside operations net.	Taxes.	Operating (or deer.) income comp. with last year.	Increase (or deer.) last year.
		Freight.	Passenger.	Total, inc. misc.	Way and structures.	Of equipment.	Traffic.	Transportation.	General.							
Alabama & Vicksburg.....	143	\$100,829	\$43,651	\$155,490	\$23,034	\$39,584	\$4,015	\$52,687	\$5,549	\$123,869	\$31,621	-\$391	\$5,300	\$28,930	\$23,356	
Alabama Great Southern.....	309	317,994	116,142	471,540	57,015	171,540	12,176	167,473	10,716	365,259	106,281	575	14,477	91,229	1,348	
Arizona Eastern.....	367	190,622	41,281	245,551	55,862	30,147	2,624	58,999	7,587	155,219	90,632	82	11,800	78,914	2,626	
Atchafalaya, Topoka & Santa Fe.....	8,238	5,285,517	2,049,408	7,954,210	1,029,819	1,333,112	169,574	2,288,266	183,282	5,004,053	2,950,157	2,042	342,497	2,607,660	-282,392	
Atlanta & West Point.....	93	46,687	38,910	95,229	11,470	20,560	5,344	36,629	4,621	78,634	16,605	2,042	6,344	21,303	5,451	
Atlanta, Birmingham & Atlantic.....	645	173,456	53,878	247,113	43,472	43,438	14,694	104,526	10,635	216,765	30,348	.....	14,337	16,011	16,177	
Atlantic City.....	167	65,000	20,750	125,750	35,053	18,997	3,636	70,785	2,788	130,929	30,348	.....	16,152	-5,921	73,969	
Atlantic City.....	167	65,000	20,750	125,750	35,053	18,997	3,636	70,785	2,788	130,929	30,348	.....	16,152	-5,921	73,969	
Atlantic Coast Line.....	107	61,615	125,374	195,025	44,219	13,611	2,637	86,938	1,165	148,570	46,455	.....	9,000	33,584	4,664	
Baltimore & Ohio.....	4,615	2,030,385	653,197	2,924,072	417,512	505,154	47,953	1,147,975	82,987	2,201,581	722,491	.....	112,000	610,491	-108,335	
Baltimore & Ohio—System.....	4,435	1,138,346	1,308,905	8,967,456	1,147,666	1,523,242	178,618	3,217,700	229,249	6,291,475	2,675,981	-62,247	211,763	2,401,971	-10,109	
Baltimore & Ohio Terminal.....	77	239,801	47,242	183,366	18,550	20,754	782	72,836	4,739	117,671	45,695	1,014	8,052	30,657	28,716	
Bangor & Aroostook.....	631	300,279	38,211	2,484	87,604	15,783	180,637	119,642	6	180,637	119,642	.....	16,060	111,588	23,254	
Belt Ry. Co. of Chicago.....	21	2,390,962	1,281,458	3,973,644	510,210	714,939	37,034	1,818,636	102,944	3,183,321	790,323	17,831	166,221	641,933	-15,871	
Boston & Maine.....	2,244	146,400	7,946	158,889	27,665	23,417	1,131	54,909	5,936	113,058	45,831	.....	2,200	43,631	23,869	
Buffalo & Susquehanna R. R.....	91	40,724	7,999	51,336	13,534	28,778	432	22,797	3,458	69,019	-17,683	-92	1,700	-19,475	924	
Butte, Anaconda & Pacific.....	90	104,004	11,003	125,203	10,579	19,042	661	50,913	2,728	83,223	41,280	.....	2,000	39,280	35,483	
Canadian Pacific Lines in Maine.....	233	38,536	32,224	98,588	16,712	7,429	57,368	4,434	124,106	124,106	-25,518	.....	12,000	-37,518	36,421	
Carolina, Clinchfield & Ohio.....	247	208,255	16,365	229,575	17,206	20,893	7,945	39,300	11,250	96,594	132,984	.....	8,000	124,981	9,044	
Carolina, Clinchfield & Ohio Ry. Co. of S. C.....	18	8,775	1,538	10,583	928	83	1,457	2,987	458	5,913	4,670	.....	500	4,170	3,191	
Central of Georgia.....	1,915	609,102	294,312	1,003,172	180,229	219,158	35,324	391,824	43,146	869,681	133,491	6,240	49,915	89,816	-73,068	
Central of New Jersey.....	676	1,738,239	463,244	2,283,118	303,407	27,698	702,587	1,445,211	47,687	1,445,211	837,907	-12,658	122,410	702,839	557,771	
Central New England.....	277	259,870	30,508	306,862	64,093	35,201	1,115	67,809	2,723	170,941	135,921	32	10,000	125,953	53,063	
Central Vermont.....	411	252,397	82,350	358,935	36,490	50,706	8,916	151,696	6,968	254,776	104,159	-16	16,927	87,216	30	
Charleston & Western Carolina.....	341	101,768	27,065	137,506	34,532	35,482	3,646	61,579	5,267	140,506	3,000	.....	5,000	8,000	-9,391	
Chesapeake & Ohio Lines.....	2,324	3,320,365	487,145	2,944,356	333,293	587,338	51,479	986,541	67,579	2,046,230	898,326	3,671	127,155	774,882	1,953	
Chicago & Alton.....	1,028	828,969	339,336	1,250,690	228,881	254,738	41,360	491,185	29,707	1,045,871	206,819	-6,044	45,200	155,575	92,255	
Chicago, Burlington & Quincy.....	9,129	4,975,889	1,681,536	7,295,560	1,907,088	1,327,043	131,467	2,315,625	205,989	5,886,832	1,408,728	-5,965	278,987	1,123,776	-12,242	
Chicago, Indiana & Southern.....	359	351,939	25,068	390,241	52,482	100,788	8,556	127,468	12,936	302,230	88,011	617	15,282	173,346	55,510	
Chicago, Indianapolis & Louisville.....	617	442,381	148,425	645,592	93,378	95,155	18,441	234,402	13,867	455,243	190,350	.....	28,578	161,772	76,350	
Chicago Junction.....	12	180,055	15,965	196,020	12,947	983	84,809	3,074	3,074	117,778	61,871	406	406	61,871	58,376	
Chicago, Milwaukee & St. Paul.....	9,592	5,271,966	1,437,088	7,338,031	1,075,111	1,148,287	165,994	2,650,581	174,167	5,214,440	2,123,591	10,007	328,700	1,804,898	248,178	
Chicago, Peoria & St. Louis.....	255	97,562	25,165	130,563	19,644	30,885	6,872	59,376	5,191	121,968	3,955	.....	4,640	3,955	10,685	
Chicago, Rock Island & Pacific.....	7,566	3,322,680	1,445,124	5,104,714	576,159	780,676	155,186	2,201,263	150,789	3,864,073	1,240,638	-18,207	237,393	985,038	-2,632	
Chicago, St. Paul, Minneapolis & Omaha.....	1,744	838,115	358,941	1,292,225	216,822	180,738	28,450	495,428	33,006	955,344	336,981	1,044	66,272	271,553	-93,023	
Chicago, Terre Haute & Southeastern.....	351	131,677	17,510	153,008	37,815	51,265	2,761	51,445	7,972	131,280	1,743	.....	10,000	8,513	-2,164	
Cincinnati, New Orleans & Texas Pacific.....	337	787,994	149,034	959,297	98,035	240,761	24,621	280,528	19,435	663,388	315,917	-480	29,000	286,437	1,192	
Cleveland, Cincinnati, Chic. & St. Louis.....	2,014	2,015,810	674,043	2,920,459	531,444	747,278	83,372	1,232,442	60,816	2,637,352	263,107	-1,137	103,800	158,170	-207,209	
Colorado Midland.....	338	89,607	20,192	120,866	32,154	31,877	8,968	59,492	6,078	138,569	-18,183	.....	8,000	-27,734	27,807	
Colorado & Southern.....	1,069	622,385	105,896	765,736	119,699	176,707	11,496	213,434	21,945	543,281	222,455	-3,938	29,175	189,342	50,319	
Delaware & Maryland.....	411	77,502	24,863	108,083	11,873	15,082	1,918	36,070	2,649	67,592	40,491	-1,070	8,379	31,042	17,635	
Detroit & Toledo Shore Line.....	79	120,451	.....	121,022	12,730	6,629	1,279	29,145	2,417	51,200	67,822	.....	5,945	61,877	-305	
Detroit, Grand Haven & Milwaukee.....	191	124,000	47,000	197,912	36,527	36,514	5,670	131,246	4,824	214,781	-16,869	.....	2,953	-19,748	-40,999	
Detroit, River Tunnel.....	2	.....	.....	.....	2,324	2,942	.....	9,145	525	14,936	95,214	.....	6,000	89,214	6,733	
Detroit, Toledo & Ironton.....	441	127,560	10,582	151,098	33,114	59,948	2,832	88,367	5,755	190,016	-38,918	.....	5,935	-44,853	11,144	
Duluth & Iron Range.....	272	924,409	227,366	954,589	96,155	103,997	1,039	198,583	10,321	357,257	597,332	4,491	48,124	553,699	85,767	
Duluth, Missabe & Northern.....	356	1,276,094	34,534	1,317,697	110,061	104,708	1,899	212,059	12,669	441,192	876,505	2,679	66,254	812,930	206,784	
Duluth, South Shore & Atlantic.....	627	201,345	84,404	308,951	82,974	37,529	12,890	120,916	9,986	264,385	44,566	59	18,000	26,625	10,895	
EI Paso & Southwestern Co.....	982	611,418	104,334	745,277	102,246	119,490	16,293	225,110	29,743	483,882	261,895	-13,266	35,000	213,629	-46,582	
Egan, Joliet & Eastern.....	822	1,131,449	7	1,208,254	129,675	189,286	5,817	326,602	17,358	678,738	529,516	.....	50,420	479,090	36,779	
Florida East Coast.....	642	261,145	120,472	439,415	65,269	70,237	6,297	173,616	12,142	327,861	106,126	-127	18,500	72,927	30,593	
Fort Worth & Denver City.....	454	112,873	425,936	57,292	79,037	6,286	161,200	319,810	11,993	319,810	106,126	-1,285	9,086	9,086	8,404	
Galveston, Harrisburg & San Antonio.....	1,338	654,595	241,302	967,447	134,839	159,173	34,847	429,455	29,687	788,001	179,448	3,669	28,590	147,187	3,001	
Georgia.....	307	173,204	71,858	262,801	31,325	50,396	11,786	131,609	6,107	233,313	29,488	.....	2,871	26,617	29,074	
Grand Rapids & Indiana.....	578	281,584	124,020	446,390	82,936	88,007	9,816	186,861	16,602	384,222	62,168	3,268	23,641	41,795	10,623	
Grand Trunk Western.....	347	415,000	181,000	635,896	48,066	97,418	23,556	179,193	15,382	495,359	140,537	-3,881	29,877	106,779	-3,998	
Great Northern.....	7,756	5,344,069	1,247,118	7,009,940	1,672,881	1,047,000	114,662	2,791,093	106,191	4,503,895	2,505,045	-1,743	569,660	1,932,642	626,459	
Hook, Colorado & Santa Fe.....	1,595	708,645	223,110	1,002,601	168,315	184,821	26,348	425,589	30,700	835,638	166,838	.....	38,030	128,800	37,524	
Hocking Valley.....	352	630,121	70,927	755,451	79,669	148,421	9,459	217,967	13,873	469,299	286,162	.....	37,500	248,662	36,872	
Houston, East & West Texas.....	191	75,975	28,039	109,8												

REVENUES AND EXPENSES OF RAILWAYS.

MONTH OF MAY, 1913—(CONTINUED).

Table with columns: Name of road, Average mileage operated during period, Operating revenues (Freight, Passenger, Total), Maintenance of way and structures, Operating expenses (Traffic, Trans- portation), General, Total, Net operating revenue, Outside operations, Taxes, Operating (or loss), Increase (or decr.) comp. with last year.

REVENUES AND EXPENSES OF RAILWAYS.

ELEVEN MONTHS OF FISCAL YEAR, 1913.

Table with columns: Name of road, Average mileage operated during period, Operating revenues (Freight, Passenger, Total, inc. misc.), Maintenance of Way and structures, equipment, Operating expenses (Traffic, Transportation, General), Net operating revenue, Outside operations, Taxes, Operating income, Increase (or decr.) comp. with last year.

† Figures shown here are for period January, 1 to May 31, 1913.

The commission has suspended from June 25 until December 25, the operation of the supplement to the tariff of the Louisville & Nashville, which would advance rates for the transportation of cottonseed oil, cottonseed foots or tank bottoms, c. l., from points in Georgia and Arkansas to points north of the Ohio river, when refined in transit at Louisville, Ky.

The commission has suspended from July 1 until October 29, the supplement to the tariff of the Missouri, Kansas & Texas, which proposed to cancel proportional commodity rates applicable to the transportation of straw, c. l., from local stations on the Missouri, Kansas & Texas in Missouri, to Alton, Ill., when destined to paper mills at Federal, Ill. The present rates range from 5 cents per 100 lbs. on shipments originating at West Alton, Mo., to 6½ cents per 100 lbs. on shipments originating at North Jefferson, Mo. The advances range from ¼ of one cent to 3 cents per 100 lbs.

#### Rates on Petroleum Products Reduced.

*Milliken Refining Company v. St. Louis & San Francisco, et al. Opinion by Commissioner McChord:*

The commission found that the present rates on petroleum asphalt, petroleum road oil, and petroleum tailings from Vinita, Okla., to St. Louis, Mo., and East St. Louis and Granite City, Ill., and on refined petroleum from Vinita, Okla., to Sedalia, Mo., were unreasonable and prescribed reasonable rates for the future. (27 I. C. C., 445.)

#### Complaint Dismissed.

*Consolidated Pump Company v. Lake Shore & Michigan Southern et al. Opinion by the commission:*

The complainant asked the commission to require the defendants to furnish a switch at its factory so it could receive and deliver freight from and to the cars of the defendants. The commission decided that the record did not present a state of facts upon which the commission could order the relief sought by complainant. (27 I. C. C., 519.)

#### Rates on Iron and Steel Reduced.

*Vulcan Iron Works Company v. Atchison, Topeka & Santa Fe et al.*

The findings in original report, 22 I. C. C., 477, are modified and defendants' rate of 63 cents on iron and steel bars, steel plates, steel sheets, and structural steel, fabricated or unfabricated, to Denver, Col., from St. Louis, Mo., and other Mississippi river crossings taking the same rates, applicable on traffic originating east of the Mississippi river, is found to be unreasonable to the extent it exceeds 45 cents on all these commodities. (27 I. C. C., 468.)

#### Reparation Awarded.

*Western Fruit Jobbers' Association of America v. Chicago, Rock Island & Pacific et al. Opinion by Chairman Clark:*

The commission decided that certain advances in rates on grapes in carloads from Chicago, East St. Louis, Ill., and St. Louis, Mo., to various points in Kansas had not been justified, and ordered the former rates restored. An increase in the carload minimum weight from 20,000 lbs. to 24,000 lbs. was approved, and reparation was awarded. (27 I. C. C., 417.)

*Weyl-Zuckerman & Company v. Colorado Midland et al. Opinion by the commission:*

The complainants shipped three carloads of potatoes from points in Colorado to points in California, routed via the San Pedro, Los Angeles & Salt Lake, which, owing to washouts on the line of that road, were diverted to the Southern Pacific by the initial carrier without instructions from the owner. The commission decided that the initial carrier is liable for the resulting increase in the transportation charges. (27 I. C. C., 493.)

*Marian Coal Company v. Delaware, Lackawanna & Western. Opinion by Commissioner Meyer:*

Reparation was awarded on account of unreasonable rates charged for the transportation of anthracite coal in carloads from Taylor, Pa., to Hoboken, N. J., and New York Lighterage station, N. J. (f. o. b. vessel), in accordance with the conclusions announced in *Marian Coal Co. v. D. L. & W. R. R. Co.*, 24 I. C. C., 140, mentioned in the *Railway Age Gazette* of June 28,

1912, page 1622; and 25 I. C. C., 14, mentioned in the *Railway Age Gazette* of November 8, 1912, page 901. (27 I. C. C., 441.)

#### Jersey City, N. J., Discriminated Against.

*Allentown Portland Cement Company v. Philadelphia & Reading et al. Opinion by Commissioner Clements:*

The defendants' rates on cement in carloads to Baltimore, Philadelphia, New York, points in New England, and to Jersey City for beyond to the Southeast are the same from Evansville, Pa., in the so-called Lehigh district, as from the other cement-producing points in that district. On cement to Jersey City locally their rates are much higher from Evansville than from these other mills. Such relative adjustment on the latter traffic was held to subject Jersey City and its traffic to undue prejudice and disadvantage, and the defendants were ordered to remove this discrimination. (27 I. C. C., 448.)

#### Reconsignment and Storage of Lumber and Shingles.

*In re advances in rates for the transportation of lumber and shingles from North Pacific Coast territory to points in Minnesota, Wisconsin and other states. Opinion by Commissioner Marble:*

Carriers serving the territory between the Pacific coast and the Missouri river undertook to cancel provisions in their tariffs by which reconsignment and storage have heretofore been given at Minnesota Transfer, Minn., Aberdeen, S. Dak., and points east thereof, on shipments of lumber and shingles en route from north Pacific coast points to points east of the Missouri river. The commission decided that the proposed cancellation of storage at Minnesota Transfer and Aberdeen should be permitted, but the continuance of reconsignment at those points is required, and the proposed withdrawal of services on connecting lines, contemporaneously granted to other shippers of lumber and shingles, is forbidden. (27 I. C. C., 451.)

#### New York Suburban Fares.

*Suspension of commutation rates between New York and points in Connecticut. Opinion by Commissioner Harlan:*

This opinion is supplementary to a former decision dealing with rates from points in New Jersey to New York City. (21 I. C. C., 428.) The fares on the New Haven from Connecticut were then left out of consideration because other fares on the same line were involved in a case pending before the New York state commission. It is now held that the commutation fares of the New York, New Haven & Hartford from points in the state of Connecticut into New York City are not unreasonable, except as to certain stations specifically named in the report. These stations excepted are those from Greenwich to Stamford, inclusive. The report does not give details, but says that from Riverside, 30 miles from New York, the monthly rate, now \$10.30, must not be over \$9.25. This, says the commission, should be the basis of all the rates in this ten mile section—Greenwich to Stamford; it will put the rates on a parity with those from points farther away and with those wholly within New York state. The commission holds that 50-trip family tickets should be issued in Connecticut at rates on a parity with those for tickets of this form issued in New York state. (27 I. C. C., 549.)

#### Through Export Bills of Lading on Cotton.

*Aransas Pass Channel & Dock Company v. Galveston Harrisburg & San Antonio et al. Opinion by Chairman Clark:*

The complainant contends that the defendants refuse to establish rates on cotton from Texas producing points to Port Aransas for export, and that they refuse to issue through bills of lading on cotton for export through that port, thus extending undue preference and advantage to other ports through which they do issue through export bills of lading. The commission decided that there is a lawful basis of rates to Port Aransas which is higher than to other ports, but that defendants have failed to assess the proper rate as required by the act. No justification is shown for the exaction of any higher rate to Port Aransas than to other Texas ports, and defendants should put Port Aransas on an equality of rates with other Texas ports. The commission has no direct authority to require the issuance of through export bills of lading, but it does have

power to remove discrimination; the issuance of through bills of lading through one Texas port while refusing to issue them on like traffic through another Texas port is unjustly discriminatory and prejudicial against the latter. The defendants were ordered to cease and desist from such discrimination and to observe uniform practices in the issuance of through export bills of lading on cotton. (27 I. C. C., 403.)

**Port Arthur, Tex., Not Discriminated Against.**

*Port Arthur Board of Trade v. Abilene & Southern, et al. Opinion by Chairman Clark:*

The rate on cotton from Texas common point territory to Galveston and Port Arthur, Tex., for export is 52½ cents per 100 lbs., which includes 1½ cents for wharfage. To Texas City, at which port wharfage is free, the rate is 51 cents. The complainant contends that there is no charge for wharfage at Port Arthur; that the inclusion of 1½ cents therefor in the rate is unreasonable and unjustly prejudicial against Port Arthur; and prays that the defendants be required to establish and maintain to Port Arthur a rate of 51 cents as they now do to Texas City. The commission decided that the circumstances at Port Arthur are clearly distinguishable from those existing at Texas City; that there is a wharfage charge of 1½ cents at Port Arthur, which is included in the published rate and is paid by the shipper. That complainant's plea that with equal rates Port Arthur can not compete with Galveston and Texas City confesses the natural disadvantages of Port Arthur as compared with the other ports. It is not the province of the commission to adjust rates for the purpose of equalizing natural disadvantages; neither may carriers lawfully do so. Unjust discrimination by carriers can not be predicated upon their failure or declination to remove by preferential rates, services, or privileges the natural disadvantages of location under which one community rests in competition with another more favorably situated. The record does not show any unjust discrimination against Port Arthur in the present adjustment of rates. The complaint was dismissed. (27 I. C. C., 388.)

**The New England Investigation.**

*In re rates, classifications, regulations, and practices of carriers. Opinion by Commissioner Prouty:*

This proceeding, undertaken in consequence of numerous and persistent complaints touching general railroad conditions in New England, was instituted under the commission's general authority to investigate and report. Discussion of the matters contained in the large record entered into and the following findings made:

While there is room for improvement, New England should be well satisfied upon the whole with the passenger service of the New Haven and the Boston & Maine lines. Safety of operation has not been considered.

The freight service upon the New Haven is inferior to what it should be, although fairly comparing with that in other sections where conditions are substantially the same. The freight service upon the Boston & Maine during the period covered was extremely poor, and justified in a great measure the criticisms it received; but a very earnest attempt is being made to correct these conditions which has already produced results.

The local freight rates of New England are slightly higher than, but on the whole compare favorably with, the average in Official Classification territory; they are lower than those in other parts of the country, except the commission-made rates in certain states. The long-distance rates are lower from and to New England than from and to any other section. Its passenger fares have been more favorable to the local traveling public than in any other portion of the United States.

The outside financial operations of the New Haven for the last nine years have been wasteful in the extreme, and the methods by which those operations have been conducted are unnecessarily involved and complex. While expenditure on its road and equipment has been with a free hand, there is nothing to show that it has not been wisely made, and much to indicate that the result has fully justified the outlay. The financial condition of this company calls for careful consideration and prudent action, but gives no occasion for hysteria.

As bearing upon the proposition that the rates of transpor-

tation upon the Boston & Maine should be advanced, the financial condition of that company is analyzed and the reasonableness of its leases considered.

In discussing the remedy for present conditions in New England the following matters are considered: Steamship and trolley lines; the Boston & Albany agreement; the dissolution of the Boston & Maine and New Haven merger; an advance in rates upon the Boston & Maine.

In the opinion of the commission the following propositions lie at the foundation of all adequate regulation of interstate railroads: (a) Every interstate railroad should be prohibited from expending money or incurring liability or acquiring property not in the operation of its railroad or in the legitimate improvement, extension, or development of that railroad. (b) No interstate railroad should be permitted to lease or purchase any other railroad, nor to acquire the stocks or securities of any other railroad, nor to guarantee the same, directly or indirectly, without the approval of the federal government. (c) No stocks or bonds should be issued by an interstate railroad except for the purposes sanctioned in the two preceding paragraphs, and none should be issued without the approval of the federal government. (27 I. C. C., 560.)

**STATE COMMISSIONS.**

The governor of New York has appointed Charles J. Chase, a member of the Public Service Commission, Second district, in place of C. N. Douglass; and William E. Leffingwell, in place of Frank W. Stevens. Mr. Chase is a locomotive engineman of the New York Central, and lives in Croton. Mr. Leffingwell is proprietor of a hotel and resort at Watkins.

The Illinois Railroad and Warehouse Commission has issued an order, under the long and short haul section of the Illinois railroad act, in which the railways in the state having the long line or route between two common points are granted authority to continue and establish between such points the rates concurrently published by the shorter line, without affecting the rates to or from intermediate points on the long line. The commission further ordered that no advance in rates to intermediate points shall be made without its permission.

**COURT NEWS.**

Judge Wolverton of the United States court at Portland, Ore., has signed a decree in the Oregon & California land grant case which forfeits to the government 2,075,616 acres of land in the Willamette valley held by the Southern Pacific Company. The decree of forfeiture is based on the failure of the Oregon & California Railroad Company, and its successor, the Southern Pacific, to sell the land to settlers under the conditions prescribed by the grant. It is understood that the case will be appealed to the Supreme Court.

**ELECTRIFICATION OF MELBOURNE SUBURBAN RAILWAYS.**—The Electrification Committee has been meeting frequently to arrange details of the scheme. Among the principal questions considered have been those in connection with the bonding of the rails for the transmission of electrical energy, the provision of the requisite number of carriages suitable for electric traction, and the structural alterations in the bridges on the route. A commencement has been made with the construction of the loop line to the site of the new power house to be erected.

**PROPOSE CHINESE LINE.**—A line is proposed in Northern Kiangsu province, China, which will connect Kaifeng with some seaport. Originally it was intended to have a port at Haichow. The line would from there run through Hsuchow-fu, Kiangsu, and Kaifeng, in Honan province. This is the first section of the Lanchow Railway, destined to be one of the longest trunk lines in China. At Hsuchow-fu, it will effect a junction with the Tientsin-Pukow Railway, and at Kaifeng, with the Peking-Hankow Railway, thus making northern Kiangsu accessible to the interior provinces. The economical advantages to northern Kiangsu in this respect cannot be over-estimated, because with efficient means of communication, great developments will take place.

## Railway Officers.

### Executive, Financial and Legal Officers.

Arthur P. Foss, assistant comptroller of the Maine Central at Portland, Me., has been appointed comptroller.

J. W. Wise has been appointed freight claim agent of the St. Louis Southwestern, with office at St. Louis, Mo.

W. H. Burns, general auditor of the Chicago, Rock Island & Pacific, with headquarters at Chicago, will hereafter also have jurisdiction over the Malvern & Camden.

W. W. Brown has been appointed general attorney of the Missouri, Kansas & Texas for Kansas, with headquarters at Parsons, Kan., succeeding John Madden, resigned.

Avery Turner of Amarillo, Tex., and G. H. Schleyer, vice-president and general superintendent of the St. Louis, San Francisco & Texas, have been appointed receivers of that road.

Frank Andrews, of the firm of Andrews, Ball & Streetman, of Houston, Tex., general counsel for Texas of the St. Louis, Brownsville & Mexico, has been appointed receiver of that road.

T. C. McCampbell has been appointed acting auditor and acting treasurer of the Tennessee, Kentucky & Northern, with headquarters at Nashville, Tenn., succeeding W. H. Thompson, resigned.

Felix Jackson, formerly president and general manager of the Houston & Brazos Valley, has been elected vice-president; George C. Morris, treasurer, and E. R. Cobb, secretary; all with headquarters at Freeport, Tex.

L. E. Hodson has been appointed assistant freight auditor of the Minneapolis, St. Paul & Sault Ste. Marie, with headquarters at Minneapolis, Minn., in place of W. H. O'Neill, assigned to other duties. Effective July 1.

G. A. McFarland has been appointed freight claim agent of the Wabash, with headquarters at St. Louis, Mo., succeeding C. H. Newton, resigned to engage in other business. Mr. McFarland has been chief clerk in the general traffic department.

W. C. Nixon and W. B. Biddle have been appointed receivers of the St. Louis & San Francisco, succeeding B. L. Winchell, resigned. Mr. Nixon and Mr. Biddle, whose headquarters are at St. Louis, Mo., will continue to perform the duties of chief operating officer and chief traffic officer, respectively.

J. J. McEwen, Jr., formerly auditor of the Orange & Northwestern, and later assistant to the auditor of the New Orleans, Mobile & Chicago, at Mobile, Ala., has been appointed auditor of disbursements of the Missouri, Kansas & Texas Railway of Texas, with office at Dallas, Tex., succeeding G. W. Danner, resigned.

C. S. Mellen, president of the New York, New Haven & Hartford and subsidiary lines, has resigned the presidency of the Boston & Maine and the Maine Central. Morris-McDonald, vice-president and general manager of the Maine Central, at Portland, Maine, will succeed Mr. Mellen as president of these two roads. See a statement given out by the company in Railway Financial News.

### Operating Officers.

P. N. Place, acting superintendent of the Scranton division of the Delaware, Lackawanna & Western, at Scranton, Pa., has been appointed superintendent.

George S. Hobbs, second vice-president and comptroller of the Maine Central at Portland, Me., has been appointed general manager. (See Executive, Financial & Legal.)

Kepler Johnson has been appointed trainmaster of the third district Indian Territory division of the Rock Island Lines, with office at Haileyville, Okla., succeeding D. Van Hecke, transferred.

James T. Colbert, assistant trainmaster of the Pittsburgh, Shawmut & Northern, at St. Marys, Pa., has been appointed superintendent of car service, with office at St. Marys, and the duties of trainmaster will be assumed by the assistant superintendent until further notice.

T. G. Smith, formerly division engineer of the Smithville division of the Missouri, Kansas & Texas at Smithville, Tex., has been appointed superintendent of the Houston & Brazos Valley, with office at Freeport, Tex., succeeding E. E. Hanna, transferred. The headquarters of the latter road have been removed from Velasco, Tex., to Freeport.

J. B. Carothers, assistant to the general superintendent of the Baltimore & Ohio Southwestern and the Cincinnati, Hamilton & Dayton at Cincinnati, Ohio, has been appointed assistant to general manager of both these roads. H. B. Voorhees, general superintendent, is now in charge of the Cincinnati, Hamilton & Dayton and the Cincinnati Terminal division of the Baltimore & Ohio Southwestern, with headquarters at Cincinnati, and R. N. Begien, assistant general superintendent of the Baltimore & Ohio at Baltimore, Md., has been appointed general superintendent of the Baltimore & Ohio Southwestern, exclusive of the Cincinnati Terminal division, with headquarters at Cincinnati. A portrait of Mr. Carothers and a sketch of his railway career were published in the *Railway Age Gazette* of June 20, 1913, page 1589, and a portrait and sketch of Mr. Voorhees were published on May 10, 1912, page 1073.

R. N. Begien, who has been appointed general superintendent of the Baltimore & Ohio Southwestern, exclusive of the Cincinnati Terminal division, with headquarters at Cincinnati, Ohio,



R. N. Begien.

was born in New England, and was educated at the Engineering School of Harvard University, having been a member of the class of 1897. Mr. Begien went to Central America, and for three and a half years was a member of the Nicaragua Canal Commission. Resigning from that position he went to South America, and for a year was a railway engineer in Ecuador. He then returned to the United States to enter the engineering department of the District of Columbia. In August, 1902, he was appointed assistant engineer of the Baltimore & Ohio, with office at Somerset, Pa.,

and in June, 1908, became division engineer at Philadelphia. He was appointed assistant to engineer of the same company, with office at Baltimore, on May 1, 1910, under A. W. Thompson, and when Mr. Thompson became general manager he remained as his assistant. He was made assistant to third vice-president on May 1, 1912, and the following December was appointed assistant general superintendent, which position he held at the time of his recent appointment as general superintendent of the B. & O. S. W. as above noted.

### Traffic Officers.

E. R. Cobb, auditor of the Houston & Brazos, has also been appointed general freight and passenger agent, with headquarters at Freeport, Tex.

L. E. Johnson, agent of the Missouri, Kansas & Texas, at Bartlett, Tex., has been appointed traveling freight agent, with headquarters at Denison, Tex.

F. S. Franklin, freight solicitor of the Pennsylvania Railroad at Buffalo, N. Y., has been appointed district freight solicitor, with headquarters at Easton, Pa.

C. W. Woods has been appointed industrial agent of the Vandalia, with headquarters at St. Louis, Mo. Mr. Woods has been chief clerk to the general manager.

C. C. Lay has been appointed traveling freight and passenger agent of the Illinois Central, with headquarters at San Antonio, Tex., to succeed R. F. Bowes, promoted.

M. B. Hatfield has been appointed commercial agent of the St. Louis Southwestern at Paragould, Ark., succeeding J. A. Morgan, resigned to accept service elsewhere.

C. C. Dana has been appointed industrial commissioner of the Atchison, Topeka & Santa Fe, with office at Chicago, in place of Wesley Merritt, resigned; effective July 1.

Charles H. Freeman, commercial agent of the Norfolk & Western at Toledo, Ohio, has been appointed foreign freight agent at Norfolk, Va., succeeding W. T. Payne, deceased.

L. J. Cox has been appointed tax commissioner of the Texas lines of the Southern Pacific, and M. A. Westcott has been appointed right of way agent of the Louisiana lines, both with headquarters at Houston, Tex.

J. L. Manion has been appointed contracting freight agent of the Illinois Central, with headquarters at Evansville, Ind. W. B. McConnico has been appointed traveling freight agent, with office at Baton Rouge, La.

G. C. Toye has been appointed general freight and passenger agent of the Tennessee, Kentucky & Northern, with headquarters at Nashville, Tenn., succeeding W. H. Thompson, resigned. (See Executive, Financial & Legal.)

L. G. Lucia has been appointed division freight agent of the Chicago & Eastern Illinois, with headquarters at Salem, Ill., in place of F. E. Webster, who has been appointed chief of the tariff bureau, with office at Chicago.

D. L. Ewing, assistant general freight agent of the St. Louis & San Francisco at St. Louis, Mo., has been transferred to Kansas City, Mo., in a similar capacity, succeeding E. F. Edgcomb, who has been appointed commercial agent at that place.

C. A. Hayes, freight traffic manager of the Grand Trunk at Montreal, Que., has been appointed general traffic manager of the Intercolonial and the Prince Edward Island railways, with office at Moncton, N. B., succeeding E. Tiffin, assigned to other duties.

B. L. Winchell has resigned as one of the receivers of the St. Louis & San Francisco to become director of traffic of the Union Pacific system, with headquarters at Chicago, effective July 14. A portrait and a sketch of Mr. Winchell's career appear elsewhere in this issue.

C. E. Dewey, general freight agent of the Grand Trunk Pacific and the Grand Trunk Pacific Coast Steamship Company, Ltd., at Winnipeg, Man., has been appointed freight traffic manager of the Grand Trunk, with headquarters at Montreal, Que., succeeding C. A. Hayes, resigned.

George W. Smith has been appointed traveling freight agent of the Atchison, Topeka & Santa Fe, with headquarters at Ft. Madison, Iowa, succeeding J. W. Munsell, who has been appointed division freight agent, with office at Ft. Madison, Iowa, in place of C. C. Dana, promoted. Effective July 1.

The jurisdiction of George H. Lee, general passenger agent of the Chicago, Rock Island & Pacific, with headquarters at St. Louis, Mo., has been extended over the Malvern & Camden. J. E. Johanson, assistant general freight agent of the former road, with headquarters at Little Rock, is appointed also general freight agent of the Malvern & Camden.

C. H. Patterson, soliciting freight agent of the Norfolk & Western at Columbus, Ohio, has been appointed traveling freight agent, with headquarters at Columbus, succeeding O. W. Cox, promoted. Clifford B. Horsman succeeds Mr. Patterson, and P. C. Hodges has been appointed commercial agent at Toledo, Ohio, succeeding C. H. Freeman, promoted.

George W. Hayler, assistant general passenger agent of the Delaware, Lackawanna & Western at New York, having resigned, his former position has been abolished. Charles K. Rath, division passenger agent at Newark, N. J., has been appointed general agent, passenger traffic department, with office at New York, and J. L. Homer, city passenger agent at New York, has been appointed division passenger agent for New Jersey, with office at Newark.

A. E. Rosevear, assistant to vice-president of the Grand Trunk at Montreal, Que., has been appointed general freight agent of the Grand Trunk Pacific and the Grand Trunk Pacific Coast

Steamship Company, Ltd., in charge of Port Arthur, Ont., and the territory west of that place, with headquarters at Winnipeg, Man., succeeding C. E. Dewey, who has accepted service with the Grand Trunk, and R. J. Foreman, assistant general freight agent at Winnipeg; will succeed Mr. Rosevear.

**Engineering and Rolling Stock Officers.**

A. G. Andrew has been appointed assistant supervisor, of division No. 30, Pennsylvania Railroad, with office at Barnesboro, Pa., succeeding G. C. Smith, promoted.

The jurisdiction of C. A. Morse, chief engineer of the Chicago, Rock Island & Pacific, with headquarters at Chicago, is extended over the Malvern & Camden, effective July 1.

J. W. Orrock, division engineer of the Canadian Pacific at North Bay, Ont., has been appointed principal assistant engineer, with office at Montreal, Que., succeeding C. B. Brown, resigned.

Collingwood B. Brown, principal assistant engineer of the Canadian Pacific at Montreal, Que., has been appointed chief engineer of the Intercolonial and the Prince Edward Island railways, with office at Moncton, N. B.

H. Montgomery having resigned as superintendent of motive power and equipment of the Bangor & Aroostook, that position has been abolished, and R. Q. Prendergast has been appointed mechanical superintendent, with office at Milo Junction, Maine.

W. L. Ekin, division engineer of the Michigan division of the Vandalia at Logansport, Ind., has been appointed division engineer of the St. Louis division, with headquarters at Terre Haute, Ind., succeeding R. K. Rochester, promoted. H. C. Johnson, division engineer of the Peoria division at Decatur, Ill., succeeds Mr. Ekin. Mr. Johnson is succeeded by A. S. Bland, assistant division engineer of the Pennsylvania Lines west of Pittsburgh at Chicago.

Joseph Thomas Richards, whose appointment as consulting engineer of maintenance of way, of the Pennsylvania Railroad, was recently announced in these columns, was born near Rising



J. T. Richards.

Sun, Cecil county, Md., on February 12, 1845, and was educated at West Nottingham Academy. He entered the service of the Pennsylvania Railroad in August, 1869, as rodman and transitman at Altoona, Pa. In June of the following year he was appointed supervisor main line, Harrisburg to Newport, and from October, 1871, to March, 1873, was chief engineer construction and superintendent of various minor railroads in Maryland. He was then chief of locating engineers, making several surveys over the Allegheny mountains for an outlet for the Bedford & Bridgeport. In May, 1874, he became mining engineer in the service of the Cambria Iron Company, Johnstown, and returned to the service of the Pennsylvania Railroad in March, 1875, as supervisor on the main line from Newport to Granville. About a month later he was promoted to assistant engineer, maintenance of way, and from June, 1877, to March, 1883, was principal assistant engineer of the United Railroads of New Jersey division, and then, for over two years was assistant to the chief engineer, becoming assistant chief engineer Pennsylvania Railroad on June 24, 1885. When a change was made in the organization in March, 1893, he became engineer of maintenance of way, and on June 1, 1903, was made chief engineer of maintenance of way, which position he held until his appointment on June 17, as consulting engineer of maintenance of way of the same road, as above noted. In addition



to his duties as head of the maintenance of way department of the Pennsylvania Railroad system east of Pittsburgh and Erie, Mr. Richards was chairman of several committees for working out the plans for the New York and Washington stations and yards.

Charles Hansel, M. Am. Soc. C. E., consulting engineer, 43 Exchange Place, New York, has been appointed consulting valuation engineer for the Pennsylvania Railroad, the Pennsylvania Company and the affiliated lines of the Pennsylvania system. His appointment as a member of the committee of engineers to confer on behalf of the railroads, with the Interstate Commerce Commission and its board of engineers relative to the valuation of railroads, was noticed in the *Railway Age Gazette* of July 4, page 18.

W. R. Trowbridge, assistant supervisor on the New York division of the Pennsylvania Railroad, has been appointed supervisor on the Trenton division; R. P. Koons, assistant supervisor on the Maryland division, has been transferred to the New York division; E. L. Hoopes, assistant supervisor on the Trenton division, has been transferred to the Maryland division; E. H. Armsby, assistant supervisor on the Bellwood division, has been transferred to the Trenton division, and R. H. Hellicfl, transitman in the office of the engineer of maintenance of way, has been appointed assistant supervisor on the Bellwood division.

William D. Wiggins, superintendent of the Peoria division of the Vandalia at Decatur, Ill., has been appointed valuation engineer of the Pennsylvania Lines West of Pittsburgh, with headquarters at Pittsburgh, Pa. Mr. Wiggins was born April 28, 1873, at Richmond, Ind., and was graduated from Rose Polytechnic Institute at Terre Haute, Ind., in 1895. He began railway work in September of that year with the Pennsylvania Lines West, and was successively assistant on engineer corps and assistant engineer of the Pittsburgh division until June, 1901, when he was made engineer maintenance of way of the Cincinnati & Muskingum Valley division at Zanesville, Ohio. The following October he became engineer maintenance of way of the Cleveland & Marietta division at Cambridge, Ohio, and from May, 1902, to January 25, 1904, he held a similar position on the Toledo division at Toledo, Ohio. He was then promoted to engineer maintenance of way of the Pittsburgh division at Pittsburgh, Pa., where he remained until November, 1912, when he was appointed superintendent of the Peoria division of the Vandalia.

#### Purchasing Officers.

J. F. Marshall, whose appointment as manager of purchases and supplies of the Chicago & Alton, with headquarters at Chicago, has already been announced in these columns, was born at Tabor, Iowa, in 1869. He was educated in the high school at Tabor, and began railway work in 1889 with the Union Pacific. For about three years he was in the general freight agent's office at Council Bluffs, Iowa, and in 1893 became chief clerk to the general foreman of the locomotive department of the Chicago, Burlington & Quincy at Council Bluffs. Five years later he was transferred to the supply department of that road at St. Joseph, Mo., and in 1903 he was appointed storekeeper at Centerville, Ia. Two years later he was made general foreman of stores at Aurora, Ill., and in February, 1907, he left the Burlington to become general storekeeper of the Wheeling & Lake Erie at Cleveland. Mr. Marshall was promoted to purchasing agent of that road in 1910, which position he held until his appointment on July 1 as manager of purchases and supplies of the Chicago & Alton, as above noted.

#### OBITUARY.

Alexander Brown, signal engineer of the Chicago, Milwaukee & St. Paul, died at his home in Milwaukee, Wis., on July 7.

CHINESE RAILWAY EXTENSION DELAYED.—The proposed extension of the Peking-Mukden line, by a branch to Ichow and Chaoyang-fu from Chinchow-fu, is like many other propositions in China, being held up for want of money. The route has recently been surveyed, and estimates of cost of construction made, but patience will have to be exhibited by the engineers of the Peking-Mukden line, until the new parliament can settle down to business and see its way clear to vote the necessary expenditure.

## Equipment and Supplies.

### LOCOMOTIVE BUILDING.

THE TREMONT & GULF has ordered 1 ten-wheel locomotive from the Baldwin Locomotive Works.

THE VIRGINIA & SOUTHWESTERN has ordered 3 locomotives from the Baldwin Locomotive Works.

THE SOUTHERN RAILWAY has ordered 15 mikado locomotives and 10 Pacific type locomotives from the Baldwin Locomotive Works.

AMSINCK & COMPANY, New York, have ordered 3 mogul locomotives and 1 prairie locomotive from the Baldwin Locomotive Works.

### CAR BUILDING.

THE GEORGIA RAILROAD is building 4 coaches and 3 baggage cars at the company's shops.

THE SEABOARD AIR LINE has ordered 5 dining cars from the Pullman Company and is expected to order 10 coaches from the Pressed Steel Car Company in a few days.

### IRON AND STEEL.

GENERAL CONDITIONS IN STEEL.—Orders for new business during the past week have been small. The United States Steel Corporation has been receiving orders at the rate of about 25,000 tons a day, comparing with between 25,000 and 30,000 tons per day in the corresponding period of last month. There have been no changes in prices and the mills continue to operate at almost full capacity. Orders on the part of the railroad are exceptionally small.

KAIFENG-HAICHOW RAILWAY, CHINA.—The Kaifeng-Haichow line is of great importance, as it will traverse a wide area, pass through two provinces, extending itself to Lanchow, capital of Kansu, on the one hand and join with the Tientsin-Pukow Railway and the Peking-Hankow Railway on the other. Another probable aspect of this line is that it will make the present unimportant Haichow into a useful seaport, and thus connect the interior with the ocean routes by a straight line. The value of Haichow as a terminus is much enhanced by its favorable situation. It is near the boundary line of Kiangsu and Shantung, and it is very near to Tsingtao. It is also within a comparatively short distance of Nagasaki.

ARGENTINE RAILWAYS FOR RENT.—A project will be taken into consideration by the Argentine senate, which authorizes the government to rent the state lines in accordance with the prescriptions of the bill. This provides that renting companies are to be of known solvency and have their legal domicile in the federal capital. The lines to be rented for a period of 60 years. Tenders will be called for. The company in which any particular line is rented must undertake to improve within a stated period the actual rolling stock and to place the lines in perfect condition, said works to be for account of the nation. It will be an essential condition of the contract that the renting companies shall construct for account of the nation any new lines that may be required. The territorial lines in the North are also to be included. At the same time the question of irrigation works will also be taken into consideration and it is probable that the government will be authorized to issue bonds to the value of \$100,000,000 for the construction of the numerous irrigation works throughout the country. This work is also to be given out. Both these projects are of vital importance. Dealing with the national railways, it is a well-known fact that their administration has always been a dismal failure and that those parts of the country which have had to rely upon this system for the transport of their goods have not made the same progress as other parts of the country which have been served by private railway enterprise.—*Review of the River Plate.*

## Supply Trade News.

F. J. Lepreau has been made assistant western sales manager for the primary battery department of Thomas A. Edison, Inc., Orange, N. J., for Central Western territory, with office in Chicago.

The Chicago, Burlington & Quincy has ordered 1 scoop-wheel rotary snow plow from the American Locomotive Company, New York. The dimensions of the cylinders will be 18 in. x 26 in., and the diameter of the driving wheels will be 33 in.

Since January 1, 1913, the White Enamel Refrigerator Company, St. Paul, Minn., has furnished its all-steel collapsible bulk-heads, hatch ventilators and plugs for the following railroads: Harriman Lines, 3,098 cars; Northern Pacific, 1,100 cars; Merchants' Despatch Transportation Company, 100 cars; Santa Fe System, 900 cars. It has also since this date furnished its Bohn tanks for the following cars: Louisville & Nashville, 100 cars; American Refrigerator Transit Company, 2,000 cars. The company has also received an order from the Illinois Central for Bohn tanks for 500 refrigerator cars, and from the Harriman Lines for 36 refrigerators, porcelain enamel lined, for the new dining cars which they are about to build. During the past 18 months the White Enamel Refrigerator Company of St. Paul has received orders for complete refrigerator equipment for the following Union stations: New York Central terminal, New York City; Grand Trunk Railway Union Station, Ottawa; Detroit River & Tunnel Company's new central station, Detroit, Mich.

### TRADE PUBLICATIONS.

**ELECTRIC HOISTS.**—The Lidgerwood Manufacturing Company, New York, has published bulletin No. 12 on its electric hoists. This bulletin is well illustrated and includes concise descriptions and tables of sizes, etc.

**UNIONS.**—The Mark Manufacturing Company, Chicago, has published a small illustrated booklet on its Cold Drawn steel unions, which are intended to expand and contract in exactly the same degree as wrought pipes, with which they are used.

**AUTOMATIC CONTROL OF MACHINE TOOLS.**—The Electric Controller & Manufacturing Company, Cleveland, Ohio, has published a handsome illustrated booklet on the automatic control of machine tools, describing different kinds of control for different machines.

**SECOND-HAND RAILWAY SUPPLIES.**—The Walter A. Zelnicker Supply Company, St. Louis, Mo., has published in bulletin 139 a list of second-hand steam shovels, cars, locomotives, boilers, rails and other miscellaneous railway supplies which it has on hand. Prices are given.

**FILES.**—The Nicholson File Company, Providence, R. I., has published the eighth edition of File Philosophy. This edition, which has been revised, is illustrated and gives many hints regarding the proper method of using files and the various applications of the most common files.

**SPEED REGULATORS.**—The S. & S. Variable Speed Gear Company, New York, has published an illustrated folder on its Scriven speed regulators for machines. The folder includes sizes, capacities and prices, and tells of the saving in power that can be effected by the use of these regulators.

**COMBINATION MACHINES.**—The Wiener Machinery Company, New York, has devoted an illustrated booklet to descriptions of its Oeking solid steel frame triple combination punch, shear and bar and angle cutters and other combination machines for railroad shops and structural iron works. The bulletin includes interesting data, such as equivalent punching capacities, etc.

**CONTRACTING.**—The H. A. Strauss Company, Chicago, successor to the Falkenau Electrical Construction Company, has issued a booklet outlining the work the company is prepared to do in the capacity of consulting engineers, designing engineers, supervising engineers and general contractors. The booklet also contains brief illustrated descriptions showing features of some of its most important recent contract work.

## Railway Construction.

**CANADIAN PACIFIC.**—An officer writes that a contract has been let to Foley Bros., Welch & Stewart, Winnipeg, Man., for constructing the five mile double track tunnel in the Selkirk mountains, on the Mountain subdivision. Work on the tunnel will be started at once, and it is estimated that it will take about three and a half years to complete this improvement. (February 28, p. 411.)

**COPPER RANGE.**—An officer writes that a contract has been given to the Phil. O. Sheridan Co., Houghton, Mich., to build a section of the connecting link under construction from the southern end of the Painesdale branch southwest to a connection with the main line at a point two and a half miles north of Toivola. The work calls for handling about 50,000 cu. yds. of earth to the mile.

**ILLINOIS CENTRAL.**—An officer writes that a contract has been given to Roper Bros., Memphis, Tenn., for double tracking work on the Yazoo & Mississippi Valley from Lake View, Miss., to Lake Cormorant, 7.8 miles. The Illinois Central contemplates building mechanical facilities at the Nonconnah, Tenn., yards. The latter work has not yet been definitely decided upon.

This company has let a contract to the Robert Grace Contracting Company of Pittsburgh, Pa., for grade reduction at Villa Ridge, Ill., including 700,000 cu. yds. of cut, the material from which will be used for raising the tracks from Villa Ridge south to Cairo, Ill.

**LAUREL LIGHT & RAILROAD.**—This company is building with its own forces from Laurel, Miss., southwest to Ellisville, seven miles. The grading work has been finished and it is expected that track-laying will be completed about September 1. The work includes constructing about 500 ft. of wooden trestles and a six-story office building. S. M. Jones and F. M. Meek, Laurel, may be addressed.

**NEW YORK SUBWAYS.**—The New York Public Service Commission, First district, will open bids on July 22, for the construction of an additional section of the Broadway subway in the Borough of Manhattan, New York, to be operated by the New York Municipal Railway Corporation under the new contracts. This section extends from Union Square north under Broadway to about Twenty-sixth street. There will be an express station at Union Square, and a local station at Twenty-third street, Madison Square. The commission now has under consideration bids which were opened on June 24, for the construction of a section immediately south of this one, extending from Union Square down to the end of the present construction at a point midway between Houston and Bleecker streets. (June 27, p. 1631.)

**NORFOLK SOUTHERN.**—The Raleigh, Charlotte & Southern has completed the extension from Varina, N. C., west to Colon, about 23 miles, and trains were run on July 1, from Raleigh to Mt. Gilead, 105 miles. The road is being extended from Mt. Gilead west to Charlotte, about 55 miles. A contract was given last year to Kennefick, Hoffman & Company, Charlotte, to build this extension. (See Raleigh, Charlotte & Southern, December 6, p. 1117.)

**PEE DEE VALLEY.**—An officer writes that contracts will be let in about six days to build from Kollock, S. C., north to Rockingham, N. C., 21 miles. The maximum grades will be 1 per cent., and the maximum curvature 4 deg. There will be five trestles on the line. The company expects to develop a traffic in lumber, factory products and farming produce. W. P. McRae is the promoter, and W. L. Gillespie, Cheraw, is interested.

**RALEIGH, CHARLOTTE & SOUTHERN.**—See Norfolk Southern.

**ST. LOUIS & SAN FRANCISCO.**—An officer writes regarding the report that an extension of the Empire branch is to be built to Panama, that this work has not been authorized. The company recently completed an extension of the Empire branch from Empire, Ala., to Sipsey, 4.92 miles. The work was quite heavy, and the line crossed the Sipsey fork of the Warrior river, where a through span of 220 ft. was put up. The Maryland Coal & Coke Company is developing a new mine at Sipsey, and the output of this mine will be carried over the new extension.

**STANDARD COAL COMPANY'S LINES.**—A contract has been given by this company to the L. R. Wattis Construction Company,

Salt Lake City, Utah, it is said, to build a two and one-half mile line between the company's coal mine in Spring canyon, Carbon county, and Storrs. The mine is three and one-half miles from Storrs, and it is planned to build a railway for two and one-half miles from Storrs and a narrow gage tramway over the other mile. F. A. Sweet, president; L. F. Rains, vice-president and general manager; George Payne, secretary and treasurer, Salt Lake City.

YAZOO & MISSISSIPPI VALLEY.—See Illinois Central.

### RAILWAY STRUCTURES.

CHICAGO, ILL.—Articles of incorporation have been filed in Illinois by the Union Station Company, which proposes to erect a new passenger terminal to replace the old Union station at Canal and Adams streets. The capital stock named is \$50,000,000, of which one-fourth each is to be held by the Pittsburgh, Ft. Wayne & Chicago; Pittsburgh, Cincinnati, Chicago & St. Louis; the Chicago, Burlington & Quincy, and the Chicago, Milwaukee & St. Paul. The directors for the first year are Joseph Wood and J. J. Turner, vice-presidents of the Pennsylvania Lines; Darius Miller, president of the Chicago, Burlington & Quincy, and A. J. Earling, president of the Chicago, Milwaukee & St. Paul. The site proposed by the railways for the new station is between Clinton street and the Chicago river, Jackson boulevard and Adams street, but is not named in the articles of incorporation, because the applications of the roads for necessary ordinances are still pending before the Chicago city council.

HARTFORD, CONN.—An officer of the New York, New Haven & Hartford writes that the company has bought land on the West Side, just beyond the manufacturing section of Hartford. Tentative plans have been made for the improvement of this land, which is to be used as the site of a large freight yard for local freight. At the present time only a small freight house will be built, as the present freight business at Hartford does not warrant the completion of the plans at this time. The Canton street freight yards are being extended to provide room for about 350 cars additional.

MCADAM JUNCTION, N. B.—A contract has been given to Henry Post, Woodstock, N. B., at \$100,000 by the Canadian Pacific, it is said, for putting up new concrete and steel shops at McAdam Junction.

MONCTON, N. B.—The Intercolonial Railway will build extensions, it is said, to the present freight car shops at Moncton.

PHILADELPHIA, PA.—Terminal improvements are to be made in Philadelphia to include the removal of all grade crossings in South Philadelphia and a large increase to the port facilities, at an estimated cost of more than \$18,000,000, as agreed upon recently at a conference between city officers and representatives of the railroads. The city's share will amount to \$9,769,000; the Pennsylvania Railroad's, \$7,057,000, and the Baltimore & Ohio's, \$1,904,800. Plans in detail will be agreed on by the attorneys for the city and the railroads during the summer for submission to the city council in the autumn. The city will buy the railroad piers at Greenwich Point and Snyder avenue, and new freight yards and steamship terminals will be constructed on what is now marsh land adjoining the Philadelphia navy yard on the north. About 4,000 acres of marsh land will be reclaimed for home and factory sites. The present agreement is the result of twelve months of negotiations concerning the South Philadelphia grade crossing controversy that has been pending 25 years. The changes will have the effect of revolutionizing the facilities of the port, increase its belt line facilities so as to guarantee an indisputable "open door" for present or future railroads, and put the city in control of a mile and a half of undeveloped Delaware river front property now adjacent to the busiest section of the commercial port.

TORONTO, ONT.—Bids are wanted by B. Ripley, engineer of grade separation of the Canadian Pacific at Toronto, on July 12, for the construction of the substructure of a subway to be built at Yonge street, North Toronto.

WINOOSKI, VT.—An officer of the Central Vermont writes that a contract has been given to James E. Cashman, Burlington, Vt., for building the reinforced concrete arch and viaduct over the Central Vermont tracks, and the Winooski river at Winooski. The structure is to have a total length of 278 ft. 8 in., with a 93 ft. arch over the river. (June 6, p. 1245.)

## Railway Financial News

BANGOR & AROOSTOOK.—A semi-annual dividend of 1 per cent. has been declared on the stock, payable July 8. This reduces the annual rate paid since 1906 from 4 per cent. to 2 per cent.

BOSTON & MAINE.—As noted in our elections and appointments column, Charles S. Mellen, president of the New York, New Haven & Hartford, has resigned as president of the Boston & Maine and as president of the Maine Central. A statement given out by the New Haven management says in substance: "This change in executive management [of the B. & M. and the M. C.] means nothing more than that Mr. Mellen will hereafter devote his entire time to the affairs of the New Haven and its direct subsidiaries, and that Mr. McDonald will handle the Boston & Maine and Maine Central railroads. The change does not mean any loss of interest in the affairs of the Boston & Maine and Maine Central by the New Haven. Mr. Mellen continues in the board of directors of both roads and as a member of the executive committees. It has been found impossible for one man to handle satisfactorily the three roads and do justice to each."

CAROLINA, CLINCHFIELD & OHIO.—William A. Read & Co., New York, have bought from the company and are selling privately \$350,000 5 per cent. equipment trust notes, series D, maturing in 14 semi-annual instalments beginning January 1, 1914. These notes were issued to pay for 500 steel underframe box and stock cars, on which the company paid \$81,000 cash.

CHICAGO GREAT WESTERN.—The protective committee for Wisconsin, Minnesota & Pacific first mortgage bonds, of which James N. Wallace is chairman, has notified owners of these bonds, of which \$5,187,000 have been deposited with the committee, that the Chicago Great Western has offered to buy the deposited bonds for \$500 first mortgage 4 per cent. bonds of the Chicago Great Western of 1909-1959, and \$500 preferred stock of the Chicago Great Western for each \$1,000 principal of the W. M. & P. bonds, and a total of \$123,740 in cash for the overdue coupons to be paid to the Central Trust Company, which is the depository for the protective committee.

MAINE CENTRAL.—See Boston & Maine, also Interstate Commerce Commission decisions.

NEW YORK, NEW HAVEN & HARTFORD.—See Boston & Maine.

ST. LOUIS & SAN FRANCISCO.—The *Commercial & Financial Chronicle* says that the only issues of the "system as recently constituted" which have failed to receive interest or guaranteed dividends are the Chicago & Eastern Illinois common and preferred certificates and the New Orleans, Mobile & Chicago first mortgage 5 per cent. bonds.

B. L. Winchell has resigned as receiver, as mentioned elsewhere in this issue, and W. C. Nixon and W. B. Biddle, both vice-presidents of the company, have been appointed receivers to succeed Mr. Winchell. T. H. West continues as a receiver.

The United States Senate has passed a resolution requiring the Interstate Commerce Commission to investigate the acquisition of the St. Louis, Brownsville & Mexico by the St. Louis & San Francisco.

SAN PEDRO, LOS ANGELES & SALT LAKE.—The California railroad commission has authorized the company to issue \$1,119,000 additional first mortgage bonds for betterments and improvements, and purchase of new equipment.

CHINESE RAILWAY EARNINGS.—The statement comparing receipts of various government railways in China for the past four years, affords striking evidence of the extraordinary movement which trade exhibited despite the disturbances caused by the revolution. Judging from the pessimistic reports which had been circulated there was every reason to believe that trade returns would either disclose stagnation or a backward tendency. The railway receipts show, on the contrary, that not only did the revolution not financially depress traffic, but that the earnings were increased. Every road except the Chuchow-Pingsiang Railway chronicled an increase over the average of the three previous years, and the total net increase for the whole system is over \$6,500,000.

# Railway Age Gazette

PUBLISHED EVERY FRIDAY AND DAILY EIGHT TIMES IN JUNE, BY THE  
SIMMONS-BOARDMAN PUBLISHING COMPANY,  
WOOLWORTH BUILDING, NEW YORK.

CHICAGO: Transportation Bldg. CLEVELAND: Citizens' Bldg.  
LONDON: Queen Anne's Chambers, Westminster.

E. A. SIMMONS, *President.*  
L. B. SHERMAN, *Vice-President.* HENRY LEE, *Sec'y & Treas.*  
The address of the company is the address of the officers.

EDITORS.

SAMUEL O. DUNN, *Editor.*

ROY V. WRIGHT,  
*Managing Editor.*  
W. E. HOOPER  
B. B. ADAMS  
E. T. HOWSON

H. H. SIMMONS  
H. F. LANE  
E. A. AVERILL  
K. E. TRAYER  
A. C. LOUDON  
E. S. FAUST  
F. W. KRABGER  
A. D. CLOUD  
GEORGE L. FOWLER

Subscriptions, including 52 regular weekly issues and special daily editions published from time to time in New York, or in places other than New York, payable in advance and postage free:

United States and Mexico.....	\$5.00
Canada.....	6.00
Foreign Countries (excepting daily editions).....	6.00
Single Copies.....	15 cents each

Engineering and Maintenance of Way Edition and four Maintenance of Way Convention Daily issues, North America, \$1.00; foreign, \$2.00.

Entered at the Post Office at New York, N. Y., as mail matter of the second class.

WE GUARANTEE, that of this issue 10,100 copies were printed; that of these 10,100 copies, 8,684 were mailed to regular paid subscribers and 850 were provided for counter and news companies' sales; that the total copies printed this year to date were 251,308—an average of 4,666 copies a week.

VOLUME 55.

JULY 18, 1913.

NUMBER 3.

## CONTENTS

EDITORIAL:

Editorial Notes.....	79
The Limitations of Regulation.....	80
A New Arbitration Law.....	81
The Cause of the Stamford Collision.....	82
New Books.....	83

LETTERS TO THE EDITOR:

An Early Locomotive Boiler Explosion; by Clement E. Stretton....	83
Powdered Fuel and Explosions; by W. D. Wood.....	83
Inconveniences to the Traveling Public; by C. J. Morrison.....	84

MISCELLANEOUS:

*Studies of Operation—The C. B. & Q.....	85
*Morris McDonald.....	88
New Illinois Public Utilities Law.....	88
A Baltimore & Ohio Anniversary Celebration at Wheeling.....	89
The Decision of the Supreme Court as to Railway Land Valuations.	89
Railway Publicity Departments; by J. Hampton Baumgartner.....	90
*Life of Locomotive Fireboxes; by C. T. Rommel.....	91
Report on Stamford Collision.....	94
Railway General Foremen's Association.....	96
The Freight Claim Association.....	97
*Mark Steel Union.....	98

MAINTENANCE OF WAY SECTION.

EDITORIAL:

Editorial Notes.....	99
Motor Cars.....	100
The Effect of the Fiscal Year Upon Maintenance.....	100

MISCELLANEOUS:

Motor Cars for Maintenance of Way Forces.....	101
*The Standard Track Scale of the P. & L. E.....	103
Abstract of Engineering Articles Since June 20, 1913.....	105
Reclaiming Timber with a Resawing Machine.....	105
*Baltimore & Ohio Flood Reconstruction.....	106
*Flood Reconstruction on the Monon; by E. G. Stradling.....	110
The Burlington's Construction Organization.....	111
*Ingot Iron.....	112
The Standard Scale Testing Car of the U. S. Bureau of Standards..	114
*An Economical Traveler for Dismantling a Train Shed.....	115
An Efficient Organization for Bridge and Building Work; by M. Riney.....	116
*Chesapeake & Ohio Yard at Silver Grove, Ky.....	117

GENERAL NEWS SECTION..... 119

\*Illustrated.

THE distant signal that figured in the Stamford collision was 1,800 ft. in the rear of the home signal; and both the Federal and the Connecticut commissions say that it should have been further back. The grade of the road is descending, at about 17 ft. per mile, or less. Inasmuch as many distant signals all over the country are less than 2,000 ft. from the corresponding stop signal, these governmental deliverances will attract general notice. They say that the distance should be greater for "fast" trains; but they do not say how fast. The Interstate Commerce Commission's report goes so far as to say that if the signal had been 800 ft. farther back, or 2,600 ft. in all, *there is every reason to believe that this accident would not have occurred.* That is a pretty strong statement. There is every reason to believe that Engineman Doherty knew the road perfectly, and that he judged distances independently of the location of the distant signal. The exact location of a distant signal is of value as a landmark in case of fog; but in this case the weather was clear, and the engineman shut off steam, he says, a good distance back from the signal and before he came in sight of it. He knew that, to stop at the home signal, he must do something besides wait for a sight of the distant. His error was not due to any miscalculation or misunderstanding as to distance. And, supposing that a distant signal is wrongly located; that it does not give room for a mile-a-minute train to stop after passing it; what is to be done? Obviously that train, in fog, must not be run at unlimited speed. In clear weather, the signal being visible 1,500 ft. back, the engineman has no difficulty. At Stamford, however, all trains being required to stop, a reduction to 40 miles an hour passing the distant would, very likely, be a reasonable rule in all weathers. We are not defending the use of improper locations; we are only calling attention to the fact that these commissions are going out of their way to discuss a small secondary point and one which, so far as the published evidence goes, has no bearing at all on this particular disaster. The government condemns the road for not having changed the location of this signal, when, quite likely, the officers were for the present fully justified in using their available money for other improvements which were more urgently needed.

ANOTHER secondary matter which is made unduly prominent in the Interstate Commerce Commission's report is that of the relative importance of a second section of a train as compared with the first section. The second section, in most cases, is more likely to overtake the first than the first is to overtake the train next preceding; but, often it is the fact that a half dozen trains follow one another so closely that the difference is non-existent. On a road like the New York division of the New Haven the term "section" has little meaning, so far as safety is concerned. Train 53 in some places is scheduled only seven minutes behind train 245. With the block system all trains are on absolutely the same basis. To the extent that an engineman depends on his knowledge of what train is ahead of him, or how far ahead it may be at any given point, to that extent he is weakening his respect for the block signals; and for these absolute obedience is the only rule. In saying that engines must always be changed at exactly the same place, and that such a rule is necessary as a measure for preventing collisions, Mr. McChord discredits the block system. The function of the block system, repeatedly recommended by the commission, is to protect every train equally well, whatever its location and whether it be standing or moving. This, again, is a question which has no bearing whatever on Doherty's case, for he fully intended to stop at the home signal, which was located in the rear of the standing train.

LOCOMOTIVE boiler design, particularly with reference to the firebox construction, and the proper methods of burning the fuel—as far as they have been understood in the different stages of progress in our understanding of the principles

of locomotive firebox combustion—have been considered of prime importance in developing efficient and powerful locomotives. It must be admitted, however, that more real progress has been made in our understanding of these problems within the past few years than in all the preceding years of locomotive development. And there is still much to be learned in these respects. Laboratory experiments of different sorts have been made to determine the direction of circulation of the water and steam in the water legs, but the results have been open to criticism because of the impossibility of duplicating actual conditions. Last year George L. Fowler developed a special apparatus for making such tests in a locomotive firebox and a few observations were made on the Jacobs-Shupert and radial stay fireboxes at Coatesville, Pa. These were not extensive enough, however, to be of much real value, except that they indicated a much lower velocity of circulation than had been expected, and also showed that there was practically no fore and aft movement of the water in the water legs—probably only enough to replace the water evaporated in them. In an article in this issue on the "Life of Locomotive Fireboxes," C. T. Rommel describes some simple laboratory experiments to determine the direction of circulation in different shaped water legs. While these are open to the same objections as other laboratory tests of this kind, the way in which Mr. Rommel has checked the results with the performance of fireboxes in actual service is of considerable interest. His conclusions as to the necessity of applying the firebox sheets with reference to the direction of rolling of the sheet and as to the single piece firebox are also valuable.

#### THE LIMITATIONS OF REGULATION.

THE Interstate Commerce Commission's report on its New England situation investigation, in the opinion written by Commissioner Prouty, analyzes in detail the service, rates and finances of the New Haven and the Boston & Maine, and concludes by setting forth some rather sweeping expressions of opinion of national importance. Specific instances are cited in this report of that very high handedness in the management of public service corporations' affairs that has led to regulation, yet the report itself, in leaving a loose end for every subject discussed, marks the limitations of government regulation of privately-owned enterprise. Since, however, the general conclusions are at least in part based on the commission's findings of fact in the New England situation, it is of the first importance that these findings of fact should be thoroughly understood.

In commenting on the annual report of the New York, New Haven & Hartford for the year ended June 30, 1912, the *Railway Age Gazette* said: "From a superficial examination of the railroad company's showing in 1912, exclusive of outside operations, it would appear that the operations of the railroad itself would have been highly profitable if the company had not extended its credit and increased its dividend and interest requirements by the acquisition of boat lines, trolley lines, etc." The commission, in its report, criticizes under two heads the New Haven's outside operations. It finds that these outside financial operations have been "wasteful in the extreme" and that the "company could have done business without advance in its transportation charges and have continued to pay the stockholders a dividend of 8 per cent. had it been content to confine itself to the mere operation of its railroad property." The question of whether or not the New Haven's acquisition of trolley and boat lines was wasteful in the extreme is a specific one, and the commission's charges in this respect are serious. The question of whether or not the railroad company could have continued to do the business that it is now doing and earn the rates that it is now earning, if it had not taken steps to prevent competition, is one in regard to which there may be an honest difference of opinion.

The Interstate Commerce Commission to a certain extent shirks a consideration of this question under the orthodox expressions of abhorrence for monopoly; but that is not judicial;

the practical question cannot be turned off with simple expressions of high sounding principles.

Mr. Mellen was faced with a very serious problem. Let us take two specific instances. The New York & Stamford street car line runs from New Rochelle, where it connects with the New York city railways, to Stamford, Conn., paralleling the New Haven for the entire distance. Franchises for this line were obtained before the Mellen régime. The New York & Stamford trolley line could not under any circumstances have cost \$15,000 a mile to build. The four-track, stone-ballasted electric railroad which it parallels, with no grade crossings, with complete block signals and laid with 100-lb. rail, treated ties, screw spikes and every modern appurtenance of a railroad, cost between \$100,000 and \$200,000 a mile. The trolley line could not possibly furnish satisfactory commutation service into New York; it could not possibly furnish satisfactory through passenger service from any point on its line for the great mass of busy people into New York; it could not carry bulk freight; it could not carry coal; it could not form a link between a railroad beginning at Stamford and extending into New England. On the other hand, with fixed charges as low as \$700 a mile, it could have inaugurated an express service, a light freight service and a local passenger service at rates utterly prohibitive to the New Haven.

Another example: The New Haven's industrial department persuaded a manufacturing concern to locate on one of its branch lines in Massachusetts. It ballasted this line, laid heavy rails, gave the manufacturer a satisfactory rate on inbound coal, and in short made the possibility of the successful operation of this concern. A couple of years later a branch was thrown off from a nearby trolley line to the back door of the factory. The New Haven had been doing a passenger business, made up of workmen going from and to the factory, which, although not in itself particularly profitable, helped to pay the interest charges on this particular branch line. The trolley line, with its lower fares, quickly took away this passenger business. It then put on an express car which made a bid for and obtained small package shipments from the factory. Since the factory's business consisted very largely of comparatively small package shipments, another and another car was put on, until within less than a year the New Haven was left with the unenviable burden of supplying coal to the factory, which coal could command only about six mills per ton per mile, and of taking out what bulk freight the factory found it inconvenient to give to the trolley company. Yet the factory could not have existed without the railroad, and public opinion would not for a moment have tolerated the New Haven's abandoning its branch, not to mention the fact that there would have been no way of getting back the original investment if the company had abandoned its branch.

This was typical of the situation that Mr. Mellen had to face. Back of Mr. Mellen was the late J. P. Morgan, whose ideas of the evils of competition are embodied in the United States Steel Corporation and, in the very words, "community of interest." All of these considerations the commission has passed over with the generality of an expressed belief in competition.

There was another way in which this competition, which the New Haven has met by overwhelming force of dollars, might have been met. There is an example of what we mean in what may fairly be called a monument to the genius of American business methods which has been built up by Theodore N. Vail in the American Telephone & Telegraph Company. The American Telephone Company has had to face potential competition almost everywhere, and actual competition in many places; and the Western Union Telegraph has had to meet competition almost everywhere; but both telephone and telegraph have been markedly successful. And the public has been given a generous share of the fruits of this success. Might it not have been possible for such a genius as Mr. Vail to have taken a railroad like the New York, New Haven & Hartford, with almost unlimited financial resources, with a public quick to appreciate good service and fair treatment, and have forestalled competition by the very excellence of the service rendered?

Quite properly, this question is not even remotely touched on in the I. C. C. report; nevertheless its absence throws into clear relief the inherent weakness of government regulation of a privately owned business. Even such a highly expert and judicial body as the Interstate Commerce Commission is obliged to content itself with destructive criticism. It is true that in Commissioner Prouty's opinion more than ten printed pages are devoted to what is headed "The Remedy"; but a close reading of this opinion only leads to the conclusion that the remedy itself is negative, not positive.

The commission, as previously mentioned, divides its investigation into an analysis of service, rates and finances. As to passenger service, the commission says: "These records show that the New Haven in the past two years has distinctly surpassed any other line terminating in New York City. . . Safety of operation was not considered in this proceeding."

As to freight service, the commission finds that "the statements furnished by these outside lines show that the service of the Boston & Maine is much less reliable than that of either the Pennsylvania or the Baltimore & Ohio, while that on the New Haven is slightly inferior to the Pennsylvania, but about on a par with the Baltimore & Ohio. It is needless to observe that the time covered is so short that not much weight should be attached to the result." As to rates, the commission says: "Our examination, which has been a rather extended one, fairly indicates that freight rates between points in New England, while somewhat higher in many instances, compare favorably upon the whole with those in trunk line territory and central freight association territory. \* \* \* The long distance rates are lower from and to New England than in most other sections; its passenger fares have been more favorable to the local traveling public than in any other portion of the United States."

As to rates, the commission's findings are conclusive; as to service, it must be said, with the utmost deference to the commission, they appear to be superficial. Indeed, the commission with surprising frankness acknowledges this when it says, as quoted above, that "it is needless to observe that the time covered is so short that not much weight should be attached to the result." In studying passenger service, for instance, the commission took the most readily available figures, those furnished to the New York Public Service Commission showing percentage of trains on time. Percentage of trains on time, without any analysis of schedule, of frequency of service, of convenience of service, of territory covered, etc., means almost nothing.

In regard to the New Haven's finances, the commission's criticisms are more definite and far more serious, but still incomplete. The basis on which these criticisms are made really amounts to an acknowledgment that the commission, with all its powers of examination of books and witnesses, is unable to explain transactions which on their face look improper.

The commission makes the definite accusation in regard to the formation of the Rhode Island company and the acquisition of the Rhode Island trolley property that "in whatever aspect the transaction is viewed, the New Haven gave \$13,500,000 for nothing"; but concludes its comments on this subject with the futile, "the inevitable query is, what was the motive behind this transaction, and who made the profit? That question in the very nature of such transactions never can be satisfactorily answered." In regard to the New York, Westchester & Boston, the commission says: "Here, therefore, is an enterprise which has cost the New Haven company \$12,000,000 in excess of the value of its property upon its own showing. Again the question arises, what has become of this \$12,000,000?" In regard to the Billard-Boston & Maine transactions the commission says: "And upon this record as it stands the New Haven company has given away of the funds of that company to Mr. Billard and his associates, or to the stockholders of the Billard company, whatever that may be, between \$2,500,000 and \$3,000,000 of the property of the New Haven company."

In regard to the Mellen notes, of which so much was made

in the newspaper comments on the hearings, the commission acquits Mr. Mellen of making any improper personal gain, but adds: "If a shipper were to obtain a refund of an overcharge in the amount of 25 cents, he would be required to execute a voucher for the same and properly so; if the president of this corporation expends money in connection with the purchase of a lease, he should take a voucher for the same. If the expenditure is not such that a voucher can be taken, it ought not to be made."

Summing up the ten pages of "The Remedy": The railroad situation in New England is in need of "rest and an opportunity for constructive work;" the New Haven should divest itself of its trolley lines; the Boston & Albany should be kept entirely free from the New Haven control; the merger of the Boston & Maine and the New Haven is left almost where it was before. "If it be asked what is to be gained by the merger from an operating and traffic standpoint we answer 'very little.' \* \* \* If it be asked what is lost through the merger from an operating and traffic standpoint, the answer must be 'something substantial but not of great territorial extent';" the remedy for the apparently inadequate revenues on the Boston & Maine consists in a conclusion "upon the whole to continue the present investigation as to this particular subject," and, finally, the commission expresses the opinion that the following propositions lie at the foundation of all adequate regulation of interstate railroads:

1. Every interstate railroad should be prohibited from expending money or incurring a liability or acquiring property not in the operation of its railroad, or in the legitimate improvement, extension or development of that railroad.

2. No interstate railroad should be permitted to lease or purchase any other railroad, nor to acquire the stock or securities of any other railroad, nor to guarantee the same, directly or indirectly, without the approval of the federal government.

3. No stocks or bonds should be issued by an interstate railroad except for the purposes sanctioned in the two preceding paragraphs, and none should be issued without the approval of the federal government.

This regulation of the issue of railroad securities, the commission finds, can only be administered through the national government. The commission does not say whether or not it accepts the suggestion of the Hadley Securities Commission that federal incorporation of railroads be permitted; neither does it give any explanation of how the federal government is to take jurisdiction over the issue of securities by a corporation which is a citizen of a particular state and heretofore considered subject to the laws, in this regard, of the state which created it.

As was pointed out at the beginning of this discussion, the two definite recommendations in regard to the limitation of the activity of railroad corporations are based on the findings of fact of the commission in this case, and the weight of the commission's opinion on this matter is in direct proportion to the completeness and finality of its analysis of facts. The commission asks for further powers of regulation, but since 1907 it has had final and sweeping powers over the accounting practices of railroad companies and it is the New Haven accounting and not the railroad service and rates that the commission finds indefensibly bad. Neither corporations nor people can be regulated into being good, neither can a man be regulated into being a great railroad president. Herein lies the limitation of government regulation of railroads.

#### A NEW ARBITRATION LAW.

CONGRESS has amended the Erdman law so as to provide for boards of arbitration of six members; and the headlines of the daily papers, agitated last Sunday and Monday over the alleged prospect of a strike of the conductors and brakemen of the Eastern railroads, have become calm. The railroads will now be ready to arbitrate. This amendment—the Newlands bill, substantially as given in the *Railway Age Gazette* of June 13, page 1328—will put real efficiency into a law which, during the 15 years of its existence, has been only a fragile structure, of the most temporary kind; and yet this weak bridge has had to be traversed by some very heavy trains. And second only to the provision for

a reasonable number of arbitrators is that for employing a commissioner of mediation, to give his time exclusively to that office. In the performance of his duty this mediator will be joined by two other men, officers of the government, who, like the conciliators under the present law, have other duties taking up most of their time. This may not be in all respects an ideal arrangement, but there is good ground for expecting a decided clearing of the air. Arbitration, as between the great railroads and their employees, may now be regarded as a permanent policy. The theory that the public will not on any consideration permit a general suspension of traffic being once conceded, the railroads have no alternative but to accept any reasonable scheme of arbitration. In the new law this condition is for the first time attained. The permanent mediator is not, probably, a vital factor; but if he be a strong man he will have almost unlimited power for usefulness.

The need of a permanent officer to perform these functions of the government grows more and more pressing each day, as important questions, bewildering in their number and magnitude, constantly arise. Moreover, the time is at hand when employers must take an aggressive course; and Chairman Elisha Lee has already intimated, in his letter to the employees, that this will be done.

The railroads having had to bow to the decree of public opinion that the welfare of the people demands arbitration of disputes between employers and employees; and, the machinery of arbitration having been established on a permanent and workable footing, it will then be proper to refer to it all disputes between railways and their employees, of whatever character. Hitherto all arbitrations have been simply adjudications of demands made by employees. The result always meant a complete or partial submission by the railroad company to agreements calling for increased wages or better hours or conditions, or both. But it will be in every respect as reasonable for the railroads to go before the governmental authorities with a demand that wages be cut down, or privileges curtailed. When a railroad can show in convincing manner that certain classes of its employees are receiving far more than men receive in other trades or occupations which call for similar qualifications, and when at the same time it is confronted with the necessity of making large expenditures for improvements in structures or equipment which do not add to its income, and which improvements are forced upon it by the public, why should it not have the privilege of calling on the governmental board to take up all questions involved, and see whether a reduction of wages would not be equitable?

In the controversy now pending, that between the conductors and the brakemen and their employers in the Eastern states, one of the first points to be considered by any board of arbitrators will be the claim of the railroads that the men are already well paid for their work. A general businesslike investigation of the wages of all classes of railroad employees is a very different thing from a superficial attempt to conciliate both sides to a quarrel—which usually means only a splitting of differences—but it should go without saying that the former is the only dignified thing for a government to do.

Of course, a commission of conciliation cannot be expected to bring the millennium. Final decisions in all strenuously contested cases will still rest with arbitrators who must be chosen in each case. But if the president shall appoint a strong man, of the right character and reputation, it is not too much to hope that the relations of the railways and their employees will enter upon a new and less troubled era. A mediator free from temporary influences can give to the public much important truth which now is obscured. By the educational influence of conciliation, and by his influence between times, when employers and labor leaders are not confused by strife, he can enlighten the people (and the railways) on all sides, and improve the quality of the arbitrators' work. The railroads have too long played the role of benevolent paternalism. Employees have asked for better pay or conditions and negotiations have been conducted ostensibly as though between equals; but in point of fact many secondary features in these negotiations have been settled by the railway

waiving its right to argue its points. As one railroad officer puts it, "the employees have been ready to arbitrate up but never to arbitrate down"—and the employers have acquiesced in this course. This, as we have said, is only benevolent paternalism. But now things are changed. Railroad officers, instead of being rich barons, conferring favors on their poor employees, are more in the position of administrators of a precarious business, contesting with a body of employees who not only "feel their independence," but, having the backing of the government and the press, and enjoying the wealth of high wages, have good ground for such a feeling.

#### THE CAUSE OF THE STAMFORD COLLISION.

THE Interstate Commerce Commission's report on the Stamford collision confirms the conclusions which were reached on the first publication of the facts, and which were given in our issues of June 20 and 27; that the cause was a mistake of judgment on the part of Engineman Doherty; that his lack of experience with fast trains explains how he came to make the mistake, and that no officer of the company had taken measures to assure himself of Doherty's competency. The report says that the company has no adequate regulations for securing and recording such assurance when men are promoted. It does not give the testimony on which this statement is based, nor does it publish the names of those who gave it; but as the company has issued a defense or apology and does not deny the statement, it must be accepted as one that is well founded. Commissioner McChord lays the responsibility for this lack of necessary safety measures on the company and its operating officers, naming no one. The report specifies the neglect of the road foreman who was nearest to Doherty and who, apparently, was directly responsible for him, but beyond that the commissioner's inquiry evidently did not go. On the questions as to who appointed the road foreman, or how it came about that he did not appreciate his responsibilities, we are left in the dark. The "operating officers" are blamed as a body. The general manager, however, is in effect exonerated because of the short time that he has held that office.

For Doherty there will be general commiseration. A sensitive and conscientious man in his position will naturally take the whole responsibility; for the blame that is placed on others can give him no comfort. The roundhouse man did not settle with Doherty about the notation on the book concerning unsatisfactory brakes; but he (Doherty) on the return trip handled his train cautiously, because of not having been satisfied by the repair man, and so there is no question that he knew that the difficulty which he had complained of still required his careful attention. The alleged inadequacy of the brakes on the cars is also worthless as a palliation of the final error, for after having braked the train three or four or more times between New Haven and Stamford, the engineman knew what he had to deal with. Even if the brakes had been far less efficient than they were, he was bound to know what he could expect from them. The testimony of men from the Lackawanna and the Pennsylvania that the brakes on the cars were not 100 per cent. perfect, or that a train in that condition would not be started on their roads has no particular value for Doherty; while the two other runners who had handled those cars on that trip testified that they had found no serious fault with the brakes. The facts in regard to these cars, taken with the testimony concerning laxity at the Cedar Hill inspecting station, may indicate that the air brake standards of the New Haven road are not so high as they ought to be; but the report is too fragmentary and incomplete to warrant any conclusions on this point; and, as we have said, no conclusion would help Doherty. An engineman who has poor brakes has not the slightest warrant for running as though he had good ones.

In certain secondary matters the report of the commission is criticised in another column. It is open to criticism also for its superficial treatment of the question of steel cars. The substi-

tution of steel for wooden passenger cars is a matter involving grave financial problems, and yet these seven judicial gentlemen deal with it in the terms of the stump speech. They call for mandatory legislation, apparently assuming that to renew forty thousand wooden passenger cars at a cost of half a billion dollars would be as simple a task as to comply with the law which requires the 2,000 wooden mail cars of the country to be replaced with steel cars. Railroad managers understand the advantages of steel cars and are introducing them rapidly. To require the change to be made "at the earliest possible time" ignores the demands of other elements of the transportation plant which need money for maintenance or improvement. It cannot too often be repeated that the prevention of collisions is a duty which precedes that of ameliorating the conditions which follow a collision.

The question of the brotherhood's bad influence on discipline has not been much illuminated by the Stamford case. The *Evening Post*, of New York, called on the commission to make a "clean cut" report on this branch of the subject; but the railroad company made out such a poor case that no definite issue was raised. Even after the commission's report came out, the road issued a statement to the effect that Doherty's services had been "practically forced on the company by the enginemen" (though the general manager, in his testimony, said that he had not been coerced); but no definite evidence was presented. Mr. Bardo demanded that two years' service as engineman should be the qualification for taking charge of through passenger trains. He accepted a rule requiring only one year, because, for one reason, there was no evidence but that one year was enough. Being new in his position he compromised. The enginemen's committee seem to be chargeable with a very poor appreciation of their responsibility in this matter, for they were negotiating for a petty technical advantage when they, of course, must have known of the lack of adequate regulations for testing the qualifications of candidates for promotion. They, in effect, helped Doherty get himself into trouble by taking a job which he had not sufficiently studied. The real trouble was not a question of any particular number of years or months; it was the lack of means for training the runners; and for this the company can give no justification.

We have said that this case does not illuminate the question of labor union influence. But it is very suggestive, nevertheless, for it is just such indirect, evasive actions as this case discloses which figure in a large proportion of the charges of improper influence. Grievance committees do not directly demand that the superintendent shall do something bad; they ask for the postponement or modification of something good. When finally pinned down, they will not dispute the justice of a given punishment; they will plead with the superintendent to shut his eyes and suspend sentence. The railroad officer who has to administer discipline needs the wisdom of Solomon, the persistency of a Washington lobbyist, and the backbone of Grover Cleveland.

#### NEW BOOKS.

*Manual of Statistics; 1913 Edition.* Published by The Manual of Statistics Co., 20 Vesey street, New York. 1,104 pages. Price \$5.

The 1913 edition of this manual, which is the 35th annual issue, covers, like its predecessors, a very broad field. The very rapid incorporation of industrial concerns during the last few years has added a great number of names to the list of those which must be covered by any statistical manual including industrial companies. The 1913 edition of the Manual of Statistics, therefore, contains information in regard to numerous companies which have not before been included in this or like publications. In addition to giving mileage income balance sheet, etc., figures for railroads and industrial companies, the manual contains a very complete list of government securities and of the securities dealt in on the stock exchanges of all the principal cities of the United States, giving the high and low prices for the year.

## Letters to the Editor.

### AN EARLY LOCOMOTIVE BOILER EXPLOSION.

LEICESTER, England, July 2, 1913.

TO THE EDITOR OF THE RAILWAY AGE GAZETTE:

In the *Daily Railway Age Gazette*, of June 16, 1913, page 1411, I have seen with much interest the illustrations of the headstones of the engineer and fireman killed in 1840. However, I beg to say that it is not fair to the firm of Norris & Company, of Philadelphia, Pa., to say that the engine was built by them, or even built in America at all.

I have before me the official report of the explosion which was ordered by the House of Commons to be printed, March 8, 1841. Therein it is clearly stated that the engine in question was at the time the property of S. A. Goddard, having been built in Birmingham (England) for Dr. Church.

The Birmingham and Gloucester Railway Company allowed the engine to be tried on their rails, but it was not their property. The inquest proved that the boiler plates were not strong enough.

CLEMENT E. STRETTON.

### POWDERED FUEL AND EXPLOSIONS.

ALTOONA, Pa., July 10, 1913.

TO THE EDITOR OF THE RAILWAY AGE GAZETTE:

I thank you very much for calling my attention to the criticisms of one of your readers concerning the lack of information in my article on Powdered Fuel for Locomotives (*Railway Age Gazette*, July 4, 1913, page 13) as to its liability to explosion.

I can say positively that there is absolutely no danger of explosion of powdered fuel where ordinary sensible precautions are observed. The writer has worked in cement mills, burned powdered fuel himself, and knows whereof he speaks. In the first place, powdered fuel when in storage or in bulk, or on being blown into furnaces does not explode. It may puff or flare back slightly when starting up a fire in a furnace, etc., if there is not enough draft, but even this is preventable. There have been so-called explosions of powdered fuel, several of them, but not one person in ten has any idea what they are like. Several of the large cement companies, including the Atlas, Alpha, Edison and others, have had explosions, fatal ones, killing several men, but every one to my knowledge originated in the grinding room where the coal was pulverized. They are sometimes caused by a nail getting in the mill and causing a spark; sometimes by open flame when cleaning or repairing a mill. All these explosions are caused by impalpably fine dust floating in the air in suspension. This floats in layers or strata. Nails and all other pieces of iron should be removed by an electro-magnet before the coal goes to the mill, even if only to protect the mill from damages. At a recent explosion (?) in one of our biggest cement mills the facts are as follows:

A foreman and some of his men were repairing and cleaning a mill. One of the men had rammed a piece of waste on the end of a stick into a part he was cleaning and somehow (no one knows) it caught fire as he pulled it out. Immediately there was a swift hissing sound like a pinwheel going off, or escaping steam, and in a flash this indescribable death traveled the length of the room, down a stairway and back several times in layers just like a train of powder, only there was no report, no explosion, just a hissing. The men came out—they were absolutely denuded, yet seemed to retain all their faculties. The foreman said: "I'm done for and am going to die." He still had enough life in him to tell what had happened before he became unconscious. They all died very shortly afterward.

As terrible as this seems, it is entirely preventable. I have never seen a cement mill yet where you could go near the coal pulverizing room, much less in, without soon becoming covered with coal dust. Yet at the American Iron & Steel Company's plant in Lebanon (they use powdered coal exclusively and have



for eight years) I stood inside the grinding room and laid a white handkerchief on my sleeve and it caught not a grain of dust. Needless to say this concern will have no explosions. The cement mills seem to think it cheaper to take a chance as long as things keep running than to spend enough money for safety. The Edison plant, after its fatal explosion, ground its coal much coarser, but if it was ground only one-fourth as fine it would still have a certain percentage of impalpable dust which is liable to explode.

There are two ways to be safe—use a mill that is tight, and spend enough money for competent labor and materials to keep it in repair.

Now as to the storage and burning. Coal, pulverized and stored in tanks, is 100 per cent. less liable to explosion than oil. It sometimes catches fire from spontaneous combustion or otherwise, and nothing happens any more than what would happen if a pile of slack coal caught fire. It is not even necessary to shut down. All that is necessary is to go right on drawing it off in its semi-burnt state, cutting off the supply to the bin that is afire, and burn it till it is all out of the tank, when a new supply may be put in if the tank has not become heated, care being first taken to see that none of the burnt coal remains.

In a large cement mill where I was employed, I have many times had to walk along the iron gallery in front of the supply boxes. This gallery is practically right over the front end of the kilns and only 8 ft. above them. The coal dust which has overflowed the boxes is always from 2 to 4 in. thick on this walk. Even when careful (which no one is) a person kicks showers of this fine dust right down over the open red hot end of the kilns; it is sometimes kicked down over a new man for a joke. Clouds of this drift down over the kilns and are harmlessly sucked in by the draft. Certainly no severer test than this could be desired.

Powdered fuel is safe—safe as coal in chunks, if common sense and judgment are exercised—and any one who believes to the contrary is simply laboring under a misunderstanding of the facts in the case.

Open dryers should not be used, i. e., dryers in which the heat and flame come in direct contact with the slack coal. This is dangerous and should not be tolerated, though some concerns use it. There are plenty of good compartment dryers on the market which are safe.

W. D. Wood.

#### INCONVENIENCES TO THE TRAVELING PUBLIC.

New York, July 11, 1913.

TO THE EDITOR OF THE RAILWAY AGE GAZETTE:

I was very much pleased with your comment in the *Railway Age Gazette* of July 4, 1913, page 1, on the endeavors of the railroads to conciliate the traveling public, and the action of one president in employing a man to travel over his road and to report to him items from the passenger's standpoint. In my opinion, what is greatly needed today is a harmonious condition between the railroads and the public. This can be brought about by eliminating the little inconveniences over which people make so much trouble, and by taking the public into the confidence of the roads and explaining the railroad side of all situations to them.

The human mind, as well as the human body, is very peculiarly constructed so that the average individual makes more fuss over a small injury, or a small inconvenience, than he does over a serious illness or some great trouble. In railroad travel it is the little things that annoy the public and cause it to take sides against the railroads.

In many stations great inconvenience is caused to the passengers, and also considerable risk, by the manner in which the baggage trucks are handled. It is quite customary for three or four men to charge down upon a body of passengers, sometimes with loud cries of "get out of the road," and at other times without even this discourteous warning. At a station the

other day the writer saw a passenger rolled over with a truck and only saved from serious injury by the quick action of an usher who, at considerable risk to himself, sprang across a track and saved the man from falling under an approaching train. This method of handling the trucks is absolutely unnecessary, and its elimination would certainly appeal to all travelers.

Considerable inconvenience and some trouble is also caused by moving trains after they have been opened to receive passengers. It is very easy, by this action, to throw a passenger and cause some minor injury. A very frequent sight is a nervous passenger, usually a lady, rushing after one of these moving trains because it is supposedly leaving the station. When trains are open to receive passengers, they should stand still until the passengers are aboard and the train ready to go.

At a number of stations the passengers are invariably herded behind the gates until the last few minutes before a train is ready to start, and then must file by a guard and have the tickets punched. In many places no judgment is used in this matter, and no matter how great the crowd, it must all pass through one gate in a small space of time. This evil has been recognized at the Broad street station of the Pennsylvania Railroad. Whenever there is an unusual crowd two, and sometimes three, gates are opened. At other places this is never done, and the writer has even been stopped when he went through a gate opened for a local train, and then attempted to cross over behind the trains to the one he wished to take. He was stopped for the reason that his ticket had not been punched.

Why punch the tickets? What useful purpose does this procedure fill? The writer can readily understand how it is a protection both to the travelers and to the railroad to have the tickets examined and thus make sure that each person is getting aboard the proper train, but why delay and annoy the passengers by punching the tickets?

The porters, who were originally employed to assist the passengers, have become in some places the greatest nuisance around the station. They are worse at the Grand Central station in New York than anywhere else. At this station they so crowd around the vestibules of the trains, that a passenger can only alight by pushing them aside. Not only this, but frequently a few of the porters, who have been a little late in noticing the arrival, come charging down the platform, causing the passengers either to get out of the way or be run over. These porters are supposedly employed by the railroad company to assist passengers free of charge, but I have yet to see one of them assist a passenger where there is no prospect of paying. In fact, a common sight in stations is a mother with several small children, and a couple of bags, doing the best she can to get through the station unassisted, while the prosperous looking man with a small satchel of a few pounds weight has a porter.

These are of course small items, but they cause great annoyance and inconvenience, and moreover could be remedied at no expense to the railroad.

C. J. MORRISON,  
Chief Engineer, Froggatt, Morrison & Co., Inc.

NEW LINE IN HAITI.—Very slowly has railway progress proceeded in Haiti, but latterly further and more successful efforts have been made to open up some of the little-known back country to the railway. The latest addition to the limited mileage is 19 miles from Gonaives to Ennery, which have been built for the Haitian government by the National Railroad Company. The line boasts of two bridges, one depot at Gonaives, stations at Gonaives, Passe-Reine and Ennery, a machine-shop at Gonaives and one or two small outbuildings. The rolling stock consists of two Baldwin locomotives, one first-class passenger-car, one second-class, and two third-class cars, as well as two box-cars, two cattle cars and two flat cars. Further construction, but still upon a modest basis, is to be undertaken by the same company.

# STUDIES OF OPERATION—THE C. B. & Q.

A Growth in Freight Traffic from 1901 to 1912 of 98.3 Per Cent.  
Was Handled with a Decrease of 9.8 Per Cent. in Train Miles.

In 1901 the Chicago, Burlington & Quincy moved 3,871,337,916 revenue ton miles of freight with a revenue freight train mileage of 18,397,431. In 1912 this road moved 7,675,979,757 revenue ton miles of freight with a revenue freight train mileage of 16,688,629. In other words, although the amount of business handled by this road increased 98.3 per cent. in eleven years, it was moved with an actual decrease of 9.8 per cent. in revenue freight train mileage. This result was brought about by an increase in this same period of 118 per cent. in the revenue train load. As the expenses of a railroad depend very largely upon its train miles, and net earnings naturally respond to an increase in the train load, a record so unusual as that of the Burlington can be studied to good advantage. Efficient railway operation may be summarized by the statement that the earnings are measured in ton miles while the expenses are counted in train miles. Few

fluctuations in business. It is also interesting to note that although the train loading decreased slightly when the business fell off in 1907, it did not fall to the same extent as did the business, again illustrating the same difficulty.

The results obtained in the operation of the Burlington are best emphasized by a comparison with the corresponding figures on other roads operating in the same territory and carrying largely the same general traffic. The Chicago & North Western, Chicago, Milwaukee & St. Paul, and Chicago, Rock Island & Pacific are the roads most directly comparable with the Burlington. Thus, while the average revenue freight train load on the Burlington for 1912 was 438 tons, the train load on the North Western was 299 tons, that on the Milwaukee was 288 tons and that on the Rock Island was 278 tons. On the other hand, the Great Northern train load was 601 tons. In 1902 the

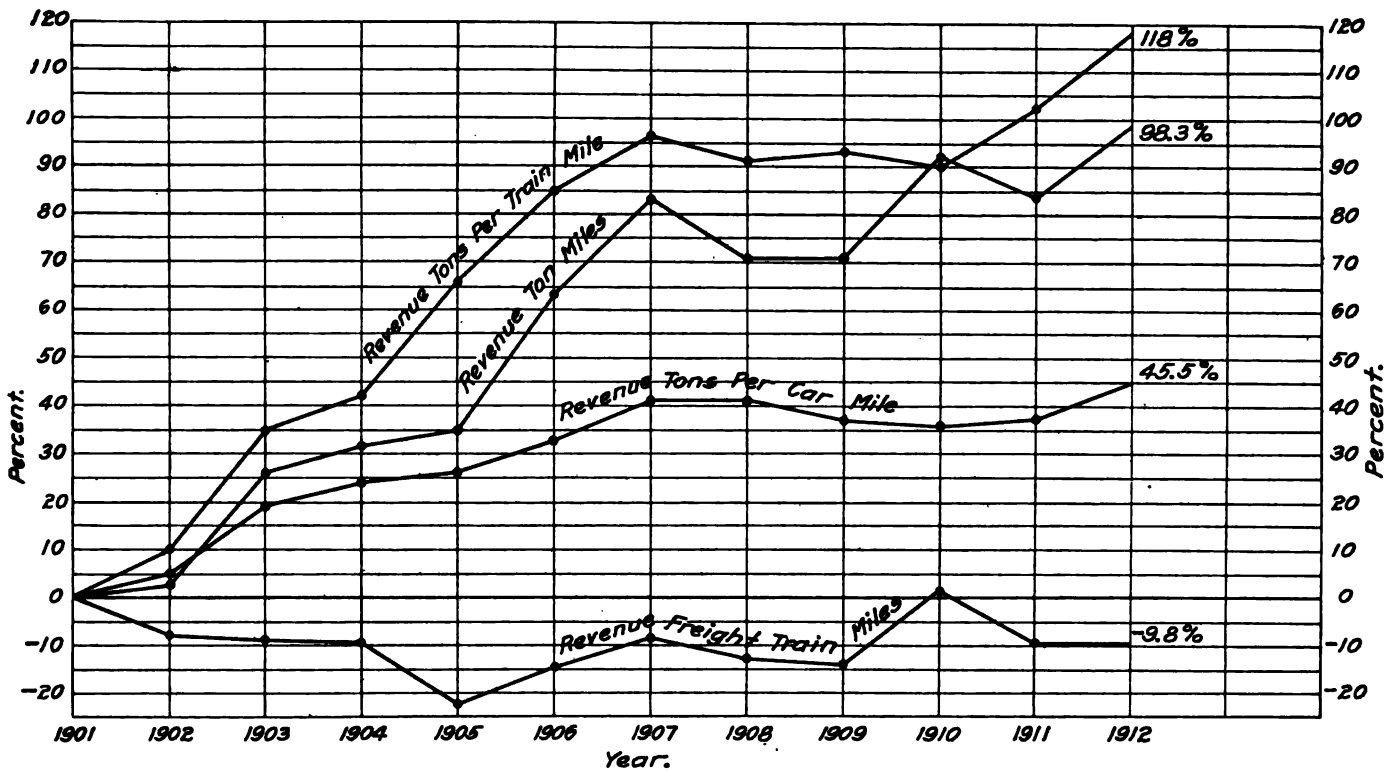

Increases in Traffic and Train Load on the Burlington as Compared to 1901.

opportunities have been offered for as clear cut a comparison of different methods of operation, and the results secured by the Burlington are of unusual interest for this reason.

That these increases in revenue ton miles and revenue tons per train have not been the result of a spurt occasioned by unusual conditions, but rather of a steady development of operating methods, is best shown by the accompanying diagram, from which it can be seen that the increases are fairly uniform in direction. Their upward inclination in 1911-12 also indicates that the limit has not yet been reached. It is interesting to note that since 1902 the average freight train mileage has been comparatively constant and the large increases in traffic have been taken care of by increasing the train load. It should also be noted that the rate of increase in the train loading has been above that of the traffic at all times during this period except in 1910, when, coincident with the large increase in traffic, there was a slight decrease in the train load and a corresponding comparatively large increase in train mileage, illustrating the difficulty of adjusting operating conditions promptly to wide

average revenue freight train load on the Burlington was 200 tons, on the Rock Island 178 tons, on the North Western 232 tons, on the Milwaukee 237 tons, and on the Great Northern 381 tons. Thus, while the train loads have shown a creditable increase on the other roads, they have not increased to nearly the extent to which they have on the Burlington or Great Northern. Therefore these increases are not to any large degree the result of local conditions in the territory through which the road operates. This comparison should not be taken as a criticism of the North Western, St. Paul or Rock Island, for these roads are generally recognized as being very well operated and maintained, but is meant merely as a comparison of the results gained by different methods. This difference in the results of different methods has been strikingly illustrated very recently on the Baltimore & Ohio. Although it is less than three years since President Willard, who was formerly operating vice-president of the Burlington, took charge of the Baltimore & Ohio, the revenue train load was increased last year 114 tons over that of the year before.

That the high train loading of the Burlington is not due to a preponderance of trunk lines between important commercial centers is best shown by the fact that 53 per cent. of the mileage of this road consists of branch lines which produce only nine per cent. of the traffic, and that 91 per cent. of the total business is handled on the remaining 43 per cent. of the lines. The Burlington has long followed the policy of intensive development of its territory by the acquisition of branch lines or feeders, as is especially evident from a study of the railway maps of Central Illinois, Southern Iowa, Northern Missouri and Southern Nebraska. While valuable as feeders, these branches seriously retard the development of high average train loads.

The class of traffic handled very materially influences the train loading of any road. The traffic handled by the Burlington is largely the same as that of the other roads in the same territory, but its average haul is 255 miles, as compared with a haul of 138 miles on the North Western, 192 miles on the Milwaukee and 242 miles on the Rock Island. This factor is of material assistance to the Burlington in increasing its train loading. Also, the Burlington is now a heavy carrier of coal. About 32.2 per cent. of all freight traffic handled by it in 1912 was bituminous coal and 41.6 per cent. of its business was products of mines. This traffic lends itself readily to heavy train loading and has been so developed on the Burlington as to give a long haul; the haul on this traffic being considerably above the average haul on all traffic. On the other hand, the Burlington handles a smaller amount of iron ore or forest products than either the North Western or the Milwaukee. It also handles more live

and a maximum grade of 0.2 per cent. While the mileage of main line has increased from 7,789 to 9,074, or 16.5 per cent. in the 11 years, the percentage of second and third main tracks to first track has risen in the same period from 5.8 per cent. to 8.7 per cent. In the same period the mileage of side tracks has increased 52 per cent. and is now equal to 28 per cent. of the main track mileage, comparing very favorably with that of other roads in the same territory.

Large amounts have also been spent in raising the general standards of maintenance. While the earnings of the Burlington have increased rapidly with the increase in train loading in spite of the fact that the average rate received per ton mile has steadily fallen from 8.6 mills in 1901 to 7.5 mills in 1912, the policy of the management has been to return into the property all earnings after the payment of fixed charges and eight per cent. upon the stock. Thus, while the capitalization is only \$33,500 per mile, and is now actually less than it was 10 years ago, the property has been very generally improved and is in excellent physical condition. The expenditures per mile for maintenance for the last five years were \$7,590, or an average of \$1,518 per year, which is considerably above that of other roads operating in the same territory.

In making improvements of any magnitude, the needs of the line and the results to be secured are very carefully studied. Special attention has been given to a study of branch lines to determine where expenditures for the improvement of the road-bed and structures would permit heavier train loading and the use of heavier locomotives. In some instances the improvement

Year Ending June 30.	OPERATING STATISTICS, 1901-1912,				CHICAGO, BURLINGTON & QUINCY.				
	Revenue Tons	Per cent. Increase Over 1901.	Rev. Tons per Train Mile.	Per cent. Increase Over 1901.	Rev. Tons per Car.	Per cent. Increase Over 1901.	Revenue Frt. Train Miles.	Per cent. Decrease Below 1901.	Average Operated Mileage.
1901.....	3,871,337,916	2.5	200.43	10.0	12.50	4.2	18,397,431	...	7,753
1902.....	3,970,277,901	25.0	228.52	35.3	13.02	18.2	16,944,726	7.9	7,941
1903.....	4,873,589,690	31.6	271.24	41.8	14.77	23.9	16,784,943	8.9	8,305
1904.....	5,101,521,081	34.4	284.16	65.5	15.49	25.8	16,647,377	9.5	8,323
1905.....	5,188,952,589	62.8	332.28	84.8	15.73	32.2	14,198,894	22.8	8,553
1906.....	6,303,883,569	83.5	370.38	96.1	16.53	40.5	15,742,307	14.5	8,608
1907.....	7,114,843,286	70.4	394.06	93.0	17.54	40.3	16,773,037	8.9	8,863
1908.....	6,604,633,576	70.9	384.26	89.8	17.08	36.6	15,975,838	13.2	8,977
1909.....	6,620,646,367	91.7	387.44	102.0	16.99	35.9	15,823,841	*1.0	9,023
1910.....	7,435,144,216	83.8	381.26	118.0	17.21	37.6	18,595,294	9.8	9,072
1911.....	7,116,005,120	98.3	406.33		18.20	45.5	16,608,998	9.8	9,072
1912.....	7,675,979,757		437.75				16,688,629	9.8	9,074

\*Increase

stock than any other road, handling 1,830,064 tons last year; and this traffic is not susceptible to heavy loading.

The heavy train load on the Burlington must, therefore, be explained very largely by other reasons and one must conclude that it is brought about rather by a definitely arranged system than by natural conditions. The means adopted to bring about these results are in the main, the reduction of grades and the development of high standards of maintenance, the use of heavier engines and cars, the development of a heavy long haul traffic, and, most important, the close, careful supervision of all the details governing train loading and operation.

Large expenditures have been made for the reduction of grades on certain lines handling heavy traffic, although this work has been thus far confined to a comparatively few lines. The most prominent instance of this work has been the reduction of the maximum grade from 1.2 per cent. to 0.3 per cent. from Centralia, Ill., to Savanna, a distance of 331 miles, in connection with an extension from Centralia south to Herrin in the southern Illinois coal fields, giving a continuous ruling grade of 0.3 per cent. from Herrin, Ill., to St. Paul, 625 miles. By this reduction of grades, combined with the use of heavier engines, which will be referred to later, the tonnage rating on this line has been increased from less than 800 tons to 3,800 tons.

Equally large expenditures have been made for additional main and side tracks to handle the increased business. The most prominent work of this nature is the construction of a second track south 300 miles from St. Paul, which has been in progress for the past four years, involving a very heavy expenditure in order to secure a line with a maximum curvature of one deg.

of these lines has been found to permit of increasing the train loading without any change in power. Other branches have been strengthened to allow the use of heavier engines. Many lines have thus been improved at relatively small cost, not with the purpose primarily of reducing the cost of maintenance but rather of securing greater train loads and decreasing the final cost of operation. The utilization of engine cinders may be cited as one example of the manner in which these branch lines have been improved with a relatively small expenditure. Up to about five years ago cinders were regarded as a source of expense and suitable only for filling material. At about this time a well defined programme was formulated for the utilization of these cinders as a ballast for branch lines. Since that time certain lines have been selected for improvement each year. The cinders are loaded in coal cars at the various terminals and the cars are routed over these branches on their return trip. The local freights unload a few cars each day, eliminating work train expense so that practically the only cost is that of putting the cinders under the track, for the cars would otherwise be returned to the mines empty. By this programme 1,144 miles of track were ballasted in the four years 1908-11, inclusive.

Coincident with the reduction of grades and the improvement of lines, important advances have also been made in the adoption of heavier motive power and new equipment of greater capacity. With the exception of a few consolidation locomotives with a tractive power of 38,000 lbs., the heaviest engines in use in 1901 were of the Prairie type with 20,000 lbs. tractive power. Since that time large additions have been made to the locomotive equipment, both in numbers and in power, and now the standard

locomotive for main line service is the mikado type with a tractive power of 60,000 lbs. However, although these mikado engines are very generally used on the main lines and some 100 are now in service, the large number of smaller locomotives on branch lines brings the average tractive power of all locomotives on the system down to about 28,000 lbs. This is, however, 40 per cent. above the *maximum* tractive power used 11 years ago. The average tractive power of the locomotives in the entire country for the year ending June 30, 1910, the last year for which the reports of the Interstate Commerce Commission are available, was 27,282 lbs. or about the same as it is now on the Burlington. The average train load in the country for the same year, however, was only 380 tons as compared with 438 tons for the Burlington. In other words, with practically the same average tractive power the train load on the Burlington exceeded that of the country at large by 15 per cent. The average train loads of the roads operating in Interstate Commerce Commission Groups VI and VII, in which the Burlington lines lie almost entirely, for the same year were 359 and 376 tons, respectively.

The distribution to the branch lines of the locomotives released from the main lines has been given as much attention as the purchase of new engines in order to place them where they would render the greatest service. On some branches with light traffic the smaller engines are capable of handling the business offered, and the use of heavier engines on these lines would not reduce the train mileage. On other lines the use of heavier locomotives has enabled the number of trains to be reduced by increasing the tonnage per train. By studies of this nature the power released from main lines has been placed on those lines where the greatest reduction in train mileage can be made, and this has had an important bearing upon the high average train loading. It is because of this that comparatively heavy locomotives are now found on numerous branch lines of the Burlington.

The condition and capacity of freight equipment has likewise been greatly improved and large numbers of new cars have been purchased. In 1905 the average age of all cars owned by the road was 22 years. This age has now been reduced to about 12 years by the destruction of many old cars and the purchase of new ones. In 1901 the Burlington owned 42,821 cars of an average capacity of 23 tons. In 1912 the number of cars owned had increased to 58,967 with an average capacity of 38 tons, while the total capacity had increased from 987,369 to 2,250,365 tons. In addition, a large number of new cars has been delivered since the compilation of these statistics. In view of the fact that the average car capacity has increased 66 per cent., it is instructive to note that in the same period the average car loading has only increased from 12.5 tons to 18.2, or 46 per cent. Considering the increase in car loading made in the country as a whole, this is a very creditable showing, but the figures illustrate the difficulty of securing co-operation from the shipper in increasing car loading equal to the effort the railway makes to increase its train loading. As shown on the curves the rate of increase of the car loading is less than that of revenue ton miles or train loading, and has been comparatively small for the last five years. In purchasing new equipment it has been the aim of the management to own as many cars as are required for the handling of business, and the success with which this has been done is indicated by the fact that there has been no well founded complaint of car shortage, even of coal cars, on its lines for several years.

An important factor in increasing the train loading has been a growth of 98.3 per cent. in the amount of business handled and especially in the long haul business. The alliance with the Great Northern and Northern Pacific has been instrumental in turning a large amount of traffic over to the Burlington at St. Paul and Billings, 15 per cent. of the total traffic of the road being secured from these connections at these points. As this is practically all long haul traffic its effect upon the totals is evident. Another important development responsible for a large increase in tonnage is that resulting from the construction of a

low grade line into the Southern Illinois coal fields in 1905. Although this line was built only eight years ago the traffic has developed to such an extent that a large portion of it is now double tracked. In this period, while all kinds of traffic has increased, the coal traffic has grown to form the largest single item of freight.

More important, however, than any influence enumerated above on the increase in train loading, is the influence of supervision. In this the example of the other Hill roads has been of assistance. While the Burlington is operated entirely separately from the Great Northern and Northern Pacific, there exist both friendly co-operation and friendly rivalry. Monthly comparisons of the reports of the three roads are prepared and sent to each road regularly so that each officer can see what his road is doing in comparison with the others and can profit by the experience of the others.

All officers from the executives down to the local division forces are trained to watch the train loading and car movements closely. Daily division tonnage sheets are closely studied and every effort is made to reduce light train movements. To this end the local way freights and time freights are filled out with dead freight as far as possible without interfering with their schedules. Turn around trains are freely employed to haul traffic over portions of divisions of heavy grades, these trains being then set out and used to fill out other trains to full tonnage over the lighter grade portions of the divisions.

One definite result of this close supervision is shown in the average miles moved per car per day, which is over 32 miles and has been as high as 35.6. This stands out in marked comparison with the average car mileage for the country, which is slightly above 24 and has never exceeded 26. Like the train loading, this car movement on the Burlington has steadily risen until it is now about 20 per cent. greater than it was eight years ago.

As an example of the means by which supervision is extended over the system, a daily telegraphic report is made of all cars held in yards over 24 hours, with the reasons for this delay. Any cars detained unnecessarily are thus detected at once and started moving. At the same time these reports also furnish a knowledge of the condition of all parts of the system so that measures can be at once taken to overcome any shortage of power or crews or any congestion in repair or classification yards.

A record of all time freight shipments is kept by cars in the office of the superintendent of transportation. A telegraphic report of all such cars in a train is made to the superintendent of transportation by each conductor on leaving a terminal and if such a car is set out for repairs or other reasons on the road, this office is again notified of the location and reason for setting out. Thus, each car of time freight is followed from terminal to terminal until it reaches its destination and can be definitely located either in a yard or in a train between two terminals at any time. While these reports are not necessarily original with this road, the care with which they are followed up is not general on other roads and accounts in a large measure for the increased car loading as well as the train tonnage. What is more important, this close check enables the road to give regular and prompt service, and there are less complaints from shippers of delays than there were before this system was inaugurated. The figures quoted before as to the average movement per car per day are perhaps in themselves a sufficient answer to any criticism that the increase in train tonnage has been followed by slower movement of the freight.

It will thus be seen that while the high figure of 438 revenue tons per train is undoubtedly due to a limited extent to the heavy proportion of traffic in products of mines, it is due to a much larger extent to a systematic study and development of all the various factors entering into increased train loading. The reduction of grades and the improvement of the condition of the track and structures, the use of larger engines and cars and the development of long haul freight traffic, have all been correlated under careful supervision for the common purpose of increasing the economy of operation.

**MORRIS McDONALD.**

Morris McDonald, vice-president and general manager, was on July 9 elected president of the Maine Central, and on July 16 was elected also president of the Boston & Maine. Mr. McDonald's experience has been almost entirely in the operating department, although one of the first positions he held in railroad service was that of paymaster. Mr. McDonald has a heavy responsibility to take and a difficult problem on his hands. The Interstate Commerce Commission, in its report on the New England situation, found that the freight service on the Boston & Maine was very bad, while at the same time it commented particularly on the good service being rendered on the Maine Central. The Boston & Maine is by no means in all respects up to modern standards of railroad construction, and at present it would have particular difficulty in raising new capital for any extensive improvements. Furthermore, presumably the organization of the Boston & Maine, which was in general deeply loyal to Lucius Tuttle, could hardly have transferred its fealty to the Mellen management, particularly since this management acknowledges frankly that it is physically impossible for Mr. Mellen to devote as much time to the Boston & Maine and Maine Central as these properties are entitled to.

One prediction may be made with certainty: Mr. McDonald will not only know his general superintendents by sight, but will know personally all the men on the Boston & Maine whose duties will, under any ordinary circumstances, bring them in contact with the active head of the operating department of their road. Mr. McDonald is a hard worker and expects and obtains hard work from his subordinate officers. He is a man who interests himself in every detail of the work under his charge, and one not likely to stand on ceremony in dealing with officers even a number of grades removed from the president. Mr. McDonald has a reputation of being a thoroughly competent operating man, and that is one thing that the Boston & Maine undoubtedly needs badly.

Morris McDonald was born at New Albany, Ind., August 20, 1865. He had a grammar school education and began railroad work at 18 with the Kentucky & Indiana Bridge. On January 1, 1885, he was made paymaster of the Louisville, Evansville & St. Louis, now part of the Southern Railway. He later became assistant treasurer, and then switched to the operating department as chief clerk to the superintendent, and before the end of 1892 had served as trainmaster and as superintendent of transportation. At the beginning of 1893 he went to the Central of Georgia as chief clerk to the superintendent at Savannah, acting also as assistant trainmaster on the Savannah division. In December, 1896, he was made secretary to the general manager of the Maine Central, and a year later was made general superintendent. In January, 1908, he was made vice-president and general manager.



**Morris McDonald.**

**NEW ILLINOIS PUBLIC UTILITIES LAW.**

The act passed by the last session of the Illinois legislature creating a public utilities commission to supersede the railroad and warehouse commission, goes into effect January 1, 1914. The governor is expected to appoint within a few days the five members of the commission. Of those appointed at the creation of the commission two are to serve until March 1, 1915, two until March 1, 1916, and the fifth until March 1, 1917. After the first commissioners appointed the terms are to be for six years each. The salary of each member is to be \$10,000 per annum; of the secretary \$5,000, and of the counsel \$6,000.

The law has been modeled closely after that of Wisconsin. Some of the principal features are as follows: Section 8 provides that the commission shall have general supervision of all public utilities; shall inquire into the management of their business and keep itself informed as to the manner and method in which the business is conducted. It is empowered to describe the manner in which the accounts of public utilities shall be kept, except where there is conflict with the requirements of the Interstate Commerce Commission. It is further prescribed that the accounts of public utility companies located in the state which are operated from headquarters outside the state shall be kept in an office within the state. The commission is given authority to regulate security issues, and when application is received for permission to issue securities the commission is required to hold hearings and an investigation. In applying for such authority the public utility must certify that the intended expenditure is not properly chargeable to income, and the commission may require it to disclose every interest of the directors in the transaction under investigation. Physical valuation of properties is provided for when deemed necessary by the commission.

The approval of the commission is to be required before consolidation of two or more public utilities may go into effect, and the capitalization of the consolidated company may not be more than the combined capitals of the separate corporations, plus any sum actually paid in cash for improvements. Contracts for consolidation shall not be eligible for capitalization. Contracts to operate lines jointly, acquire leases, franchises and plants, or to acquire stocks or securities of other public utilities are prohibited unless consent of the commission has been first obtained.

The provisions regarding rate regulation are similar to those in most of the recent laws of this kind, requiring the publication and filing of tariffs, and providing that rates shall not exceed those in force on July 1, 1913, except by consent of the commission. The commission is empowered to suspend new rates for 120 days, and for a further period of six months.

Certificates of convenience and necessity are to be required for any new construction or extension work, and broad powers are given to the commission to compel adequate service. The

commission is given power to issue orders directing railway companies to increase the number of trains or of cars or motive power, to change time schedules and stopping places, or to make such orders as may be reasonably necessary to accommodate and transport the traffic offered.

### A BALTIMORE & OHIO ANNIVERSARY CELEBRATION AT WHEELING.

During the semi-centennial celebration at Wheeling, June 15-21, of the admission of West Virginia to the Union as a state, the Baltimore & Ohio commemorated the sixtieth anniversary of the completion of the road to the Ohio river. A number of old locomotives which ran on the road 60 years ago were taken out of their resting places and exhibited at Wheeling, under steam, and they were run by veteran engineers now retired, who returned to active service for this occasion. Sixteen men took part in the celebration and the years of their service aggregated 775. Their names and records are as follows:

Michael Kirby, engineer, 58 years (struck blow on gold spike marking completion of Baltimore & Ohio to Wheeling, December 24, 1852); Abner T. Ingels, engineer, 53 years; Joseph J. Brady, conductor, 50 years; Ephraim Provance, engineer, 43 years; Robert Hutchinson, engineer, 50 years; Henry C. Elder, conductor, 50 years; William Fleming, brakeman, 45 years; "Daddy" John Smith, brakeman, 58 years (transferred car of President Lincoln through Baltimore on way to first inauguration, also the funeral car containing the remains of the martyred president on the way to Springfield for burial); John Seibert, Cumberland Valley Railroad, engineer, 46 years; W. O. Peach, shop foreman, 45 years; George Sturmer, general manager's office; Michael Dee, conductor, 50 years; J. H. Fosnot, brakeman and conductor, 50 years; James Mahoney, brakeman, 39 years; J. E. Spurrier, assistant to general manager, 51 years, one of the oldest railroad officers in America in active service; Z. T. Brantner, superintendent of shops, 51 years.

With the single exception of the horse-drawn car of 1830, every example shown was an original. The realism was further heightened by the movement under steam. The old engines were moved by their own power in the old Hempfield yard, where they remained during the week, and on one of the days all were marshaled in a parade, presenting a spectacle the like of which may never be witnessed again.

Old types of locomotives that in their day marked progress in railroad development as suggestively as the Mallet, Mikado and Pacific do in these times, once more came to life and were living, breathing things. Stacks that had not vomited smoke, and fireboxes and boilers that had remained cold from a quarter to half a century showed that they could "come back." The comparison of these little engines with those of the Mallet type was of course most striking.

The old Hempfield yard has eight tracks abutting on the street. It is a square in the very heart of the city, into which came the Baltimore & Ohio years ago. It contributed a huge level stage and upon it flocked thousands of spectators. The old horse-car headed the pageant. It was drawn by a gray horse, its driver perched high in front, with one foot on the bar for controlling the car, as in the stage coach of the period.

Then came the "Atlantic" of 1832, the oldest locomotive on the continent in its original form. This is one of the grasshopper type, with upright boiler.

Next in line was the "Thomas Jefferson" of 1834, of the same type as the "Atlantic," but with a cab. This engine was in service 40 years. To it was attached an old four-wheel passenger coach of 1838. This coach is in the form of a road stage coach in vogue about 70 years ago, its rounded body and two crosswise seats facing each other, with a carrying capacity of six or eight persons. Next came the "Mississippi"

of 1837, the first locomotive seen west of the Mississippi river. The Cumberland Valley "Pioneer," the Seth Wilmarth type of 1847, followed, drawing an old combined passenger and baggage coach of 1855. The "Pioneer" in 1860 ran from Harrisburg to Chambersburg in 68 minutes, including two stops for wood and water, averaging very close to a mile a minute.

The Chicago & North Western "Pioneer" of 1848 came next, the first locomotive seen in Chicago. Then came the "Dragon" of 1848, and the "Camel" of 1850. Many of the old railroaders of West Virginia still remember seeing the Camel class of engines in active service.

Bringing up the rear was the monster modern Mallet locomotive which in full working order, with tender, weighs 43 times as much as the grasshopper "Atlantic."

Major J. G. Pangborn, the well known veteran historian of the Baltimore & Ohio, had charge of the arrangements for this railroad celebration. Major Pangborn was director of the Baltimore & Ohio's remarkable historical collection at the Chicago and the St. Louis world's fairs, and these old engines were described in the book which he published in 1893.

The Baltimore & Ohio is rich with history at every turn. Senator Henry G. Davis, of West Virginia, whose birth antedates the time when a railroad was first known on this continent, was for many years in the service as brakeman and conductor. J. E. Spurrier, referred to above, was formerly a superintendent, and farther back, about 40 years ago, ran an engine. Like General Manager C. W. Galloway, Mr. Spurrier is of the third generation in the service. The grandfathers of both of these men drove horses attached to cars over the line in 1830 before the days of the locomotive. Mr. Galloway's grandfather piloted the first regular passenger car, which was little more than a clapboard cabin on four wheels holding a half dozen passengers sitting on board seats running lengthwise and each of whom was way-billed the same as freight is nowadays. The driver was perched up on a seat outside the front end and it was the elder Galloway with his celebrated gray horse, who in the historic race with Peter Cooper's experimental locomotive in August, 1830, carried off the honors.

### THE DECISION OF THE SUPREME COURT AS TO RAILWAY LAND VALUATIONS.

The following appeared as an editorial in a recent issue of *Engineering and Contracting*, the editor of which is H. P. Gillette, who was engineer of the Washington Railroad Commission at the time the valuation was made in that state.

The recent decision of the United States Supreme Court in the Minnesota rate case exemplified the old adage that a little learning is a dangerous thing. The court has made a momentous ruling as to the valuation of railway right of way, basing its ruling upon evidence that was insufficient, for it is inconceivable that the evidence was sufficient when we read such sentences as this in the court's decision:

It is impossible to assume in making a judicial finding of what it would cost to acquire the property (land) that the company would be compelled to pay more than its fair market value.

If it is judicially impossible so to do, then we have the incongruity of a court's refusing to recognize facts of every day occurrence, for not a week passes that some railway company does not pay more than the "fair market value" for land taken for right of way purposes. By "fair market value" is here meant the value of land for other purposes than railway right of way.

In the Minnesota rate case both the railways and the engineer of the Minnesota commission used "multipliers" or "public utility factors" by which to multiply the "market value" of land to determine its "right of way value." Hence the railways could not have anticipated that the Supreme Court would have seriously questioned the propriety of the use of such "multipliers" or "factors." Moreover, the engineers and the railway commissions of Michigan, Wisconsin and Washington had all used

"factors" of this sort in appraising railway right of way. This concurrence of practice arose not from following some precedent, but from independent investigations that disclosed in each state the actual existence of an excess of right of way costs over the market value of the land for farming and other purposes. If such facts had been fully presented to the Supreme Court it is hardly credible that it would have said:

The increase sought for "railway value" in these cases is an increment over all outlays of the carrier and over the value of similar land in the vicinity. It is an increment which cannot be referred to any known criterion but must rest on a mere expression of judgment which finds no proper test or standard in the transactions of the business world.

This is not true. There is a "known criterion" in almost every purchase of land for railway right of way.

The Supreme Court rules that the present value of land, and not its actual or original cost, is to be used in an appraisal for rate making. This is a very important ruling for there have been some who have contended that a railway is not entitled to the "unearned increment" in land value. The court says on this point:

It is clear that in ascertaining the present value we are not limited to the consideration of the amount of actual investment. . . . The property (land) is held in private ownership and it is that property and not the original cost of it, of which the owner may not be deprived without due process of law.

The court holds that a railway is entitled to increments in the value of its land, i. e., to share in the general prosperity of the community it serves, but the court apparently thinks that the use of any "multiplier" or "public utility factor" for right of way results in giving a railway more than its share of increment in land value. Yet a simple arithmetical calculation upsets this conclusion. Suppose farm land worth \$50 an acre 20 years ago is now worth \$100. Suppose a railway built 20 years ago paid \$150 an acre for right of way through this land—a not uncommon "multiplier" being three. Then the farm land worth \$100 today has enhanced in value 100 per cent. in 20 years. In order to secure an equal percentage of increment in the value of the railway right of way, it must be valued at \$300 an acre, or a "multiplier" of three must be applied to the \$100 value. If no "multiplier" at all is applied, we have this illogical and unfair result: Land that cost the railway \$150 an acre 20 years ago is today appraised at \$100!

The Supreme Court not only rejects the use of "multipliers" but it also rejects all overhead expenses—engineering, interest during construction, etc.—relating to the land. This ruling as to overhead charges on land is even more astonishing than the rejections of land "multipliers." With equal justice might overhead charges on all other railway property be cut out in making an estimate of the cost of reproduction.

It is quite clear, we think, that the Supreme Court made such errors as these, largely because incomplete evidence was presented by the railways. Up to the present time no steam railway, as far as we know, has presented its case properly and fully to the Supreme Court. In the Minnesota rate case the railways did not even present evidence to show the amount of their "development cost," "going value" as the Wisconsin Railroad Commission calls it. This was a serious—a very serious—omission, for "development cost" is usually more than sufficient to wipe out accrued depreciation. When the steam railways awoke to the realization that appraisal problems are complex problems—not mere inventories of visible objects—they will probably seek the advice of appraisal experts. They will learn that consulting engineers can give advice of greater worth than they usually receive from attorneys employed for consultation, for a rate case is about nine-tenths engineering—engineering of a very complex and special character—and one-tenth law.

PROPOSED LINE FOR INDIA.—A survey is being carried out by the Maharajah of Benares for a 2 ft. 5 in. gage line about 31 miles long between Moghul Serai and Ahraura via Baburi, Chakia and Shikargarh.

## RAILWAY PUBLICITY DEPARTMENTS.\*

By J. HAMPTON BAUMGARTNER,

Publicity Representative, Baltimore & Ohio.

I think that each editor at this meeting will agree with me that within the last few years there has been a marked change in business—the ethical standard of business has been elevated. Efforts are constantly being made to meet the wishes of the people upon the basis of fairness in business transactions. The attitude which formerly prevailed in some quarters, the so-called "public be damned" policy, has been changed, and today can very properly be paraphrased "public be served."

The wave of agitation which swept over the country some years ago and crystallized into antagonism toward business, was felt keenly by the railroads; and in meeting the situation they moved to get in closer touch with the public. Departments of public relations were established by some of the roads, as well as by many of the industrial and manufacturing concerns and public service corporations. Many of the railroads and the other interests I have mentioned established departments of publicity, which handle largely matters of public relations, and with the co-operation of the press, endeavor to effect a fair understanding between the business interest on the one side, the editor and the public on the other.

Before speaking more in detail of the working of the publicity department of a railroad, I wish to make a statement that an erroneous impression prevails in some quarters that the publicity departments were organized for the purpose of conducting campaigns of cheap publicity and thus obtaining a considerable amount of free advertising.

This was not at all the purpose of the railroads. A railroad regards its publicity department as the mouthpiece of the management and the point of contact with the public, largely through the co-operation of the press. The publicity department is connected with the executive offices. Trained men are in charge, and their relations with the editors and others connected with the press are transacted in a dignified manner and with a view to inspiring confidence in and dependence on the statements which they make to the press concerning the interests represented. So far as the matter of advertising is concerned, I speak with authority when I state that, on the contrary, every publicity man would be glad to see substantial increases made in advertising appropriations.

As to the character of matter which is sent to the press by the railroad publicity departments, I think it can generally be said that the articles are confined to legitimate news, such as improvements to the property or service in different sections, purchase of new equipment, news of industrial development or progressive policies of the management in co-operating with a state, city or business organization for the advancement of any condition or interest. Announcements are made also as to changes in officials and other matter which is regarded as of interest to newspaper readers living in communities reached by the various railroad lines.

This matter is sent to the editors when it is fresh news. When conditions arise which require it, the information is sent by telegraph to the newspaper office.

The publicity department aims to have the editors understand that information can always be obtained concerning the railroad company, and an agent will gladly telegraph an inquiry which comes to him from his local editor. The information thus received in the newspaper office, in response to such inquiry, is authoritative. Special information and articles are also sent in response to requests.

Another change which the publicity department has brought about in the relations between the press and the company, is in the furnishing of information concerning railroad accidents.

\*From an address before the Virginia Press Association at Mount Elliott Springs, Va., on June 26, 1913.

# LIFE OF LOCOMOTIVE FIREBOXES.

Outwardly Inclined Water Leg is Best—Direction of Rolling Sheet Important—Single Piece Firebox a Mistake.

By C. T. ROMMEL.

Considerable discussion on this subject originated with the very able paper read before the Western Railway Club several years ago by C. A. Seley, then mechanical engineer of the Rock Island Lines. It was generally agreed that the present type of wide firebox had a much shorter life than the older and more narrow type, although the material used in their construction was practically the same. Many reasons were assigned for this. Higher steam pressures are used on the boilers with the wide fireboxes than on those with the narrow ones. There is more abuse of the boilers at terminals by the hostlers and less care is taken in washing out, on account of being in a greater hurry for the power; last, but not least, is the effect of the design of the firebox.

The most important point brought out by Mr. Seley was that the design of the firebox had a very great effect on the water circulation. He said, "that the rate of flow and its wiping effect or scrubbing action can be directed against the side sheets so it has

known as the one-piece firebox; that is, the crown and side sheets are made in one piece. To this particular feature more attention will be given later on.

To get back to the point brought out by Mr. Seley, the actual results obtained in service will be interesting. In Fig. 1 are shown the outlines of the water legs of the different types of fireboxes.

Outline *A* in Fig. 1 represents five locomotives with a three-piece firebox, 5/16-in. side sheets, and a boiler pressure of 190 lbs. These had been in service 95 months. No side sheets had been renewed at the time the investigation was made. The probable life of the side sheets appeared to be 110 months.

Outline *B* represents 210 locomotives with the fireboxes in one piece, 3/8-in. side sheets, and a boiler pressure of 205 lbs. They had been in service 36 months. The average life of the firebox was 34 months.

Outline *C* represents 197 locomotives with the fireboxes in

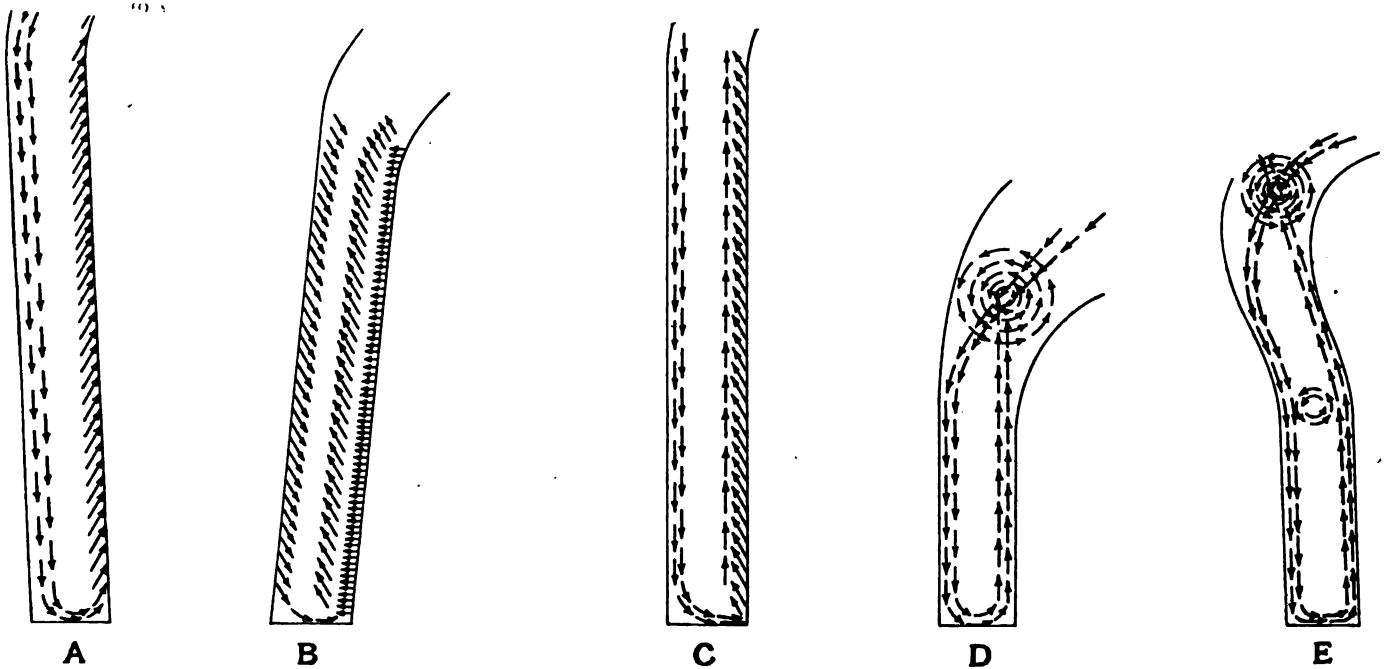

Fig. 1.—Direction of Circulation as Found in Experimental Tubes.

the effect of wiping off the steam bubbles as they form, preventing their combining into a film or curtain of steam against the sheet which is by no means as good a conductor of heat as is the solid water. This theory will account for increased internal temperature of vertical and inwardly inclined side sheets and can be inferentially proven."

Mr. Seley said that the theory could be inferentially proven. It shall be the endeavor of the writer to show that the theory can be obviously proven and the lapse of time between the reading of Mr. Seley's paper and the preparation of this article has been spent in investigating the subject along the lines suggested by Mr. Seley.

At this point it will not be amiss to state that beyond question the form of construction of the firebox and the material used also enters largely into the shorter life of the wide fireboxes. Every railroad man familiar with the mechanical department is aware of the trouble caused by the seams joining the side and crown sheets when the side sheets are separate from the crown sheet, and to overcome this trouble change was made to what is

three pieces, 5/16-in. side sheets, and a boiler pressure of 205 lbs. They had been in service 72 months. The average life of the firebox was 56 months.

Outline *D* represents 143 locomotives with three-piece fireboxes, 5/16-in. side sheets and a boiler pressure of 200 lbs. They had been in service 98 months. The average life of the firebox was 64 months. (The locomotives in this group have the Wooten type firebox.)

From this it will be seen that the results obtained in actual service show the design of firebox with the greatest inward slope and the firebox in one piece had an average life of but 34 months, while the designs with the lesser amount of inward slope and made in three pieces, had a correspondingly greater life. The longest life obtained was on the type with the outward slope, next the type shown by outline *D* (Wooten type, practically vertical); third, the type shown by outline *C*.

These results, obtained in actual service, substantiate Mr. Seley's theory, but not being satisfied with this and desiring to know just what the circulation of water would be with the dif-



ferent types, an interesting experiment was made. Glass test tubes,  $\frac{7}{8}$  in. in diameter, were bent to the form of the water legs of the different designs and connected to a filter tube with a side outlet, this outlet being provided for the purpose of allowing the steam to escape; in other words, it acted as a safety valve. The filter tube was filled with water to such a height that there would be approximately the same amount of water as there would be on the top of the crown sheet. Heat was applied by means of one or more Bunsen burners in order to get as near the actual conditions as possible, and as the steam bubbles formed the circulation of the water was observed, the steam formed escaping through the safety valves. The apparatus used is shown in Fig. 2 and the results obtained are indicated by the arrows on Fig. 1.

Of course, there will be those of doubting mind who will say that the results obtained do not represent truly the circulation of the water in the firebox legs, as there was no connection with what would represent the barrel of the boiler; while this may be true, all must admit that the apparatus used represents beyond question an element of the boiler, and while the circulation found may have been more free than that obtained in actual practice, it most certainly represents the direction of the circulation.

From Fig. 1 it will be noted that with the outwardly inclined water leg the direction of circulation as indicated by the arrow heads was towards the inner, or fire side, washing off the steam bubbles as they formed, and downward on the outer side. With the inwardly inclined leg, the circulation was away from the inner side, while the tendency on the outer side was toward the inner at an angle of about 45 degrees; as a consequence the circulation was very much retarded and the steam bubbles which formed on the inner side remained stationary until sufficient pressure was obtained to drive them away; when these bubbles left the inner side of the tube they had a tendency to drive the water with them. Conditions such as these in actual practice would beyond doubt result in abnormally high temperatures of the side sheets. It was also noted with the inwardly inclined tube that it was very easy to make the water boil over, or foam, while with the outwardly inclined tube it was impossible to obtain this condition.

With the straight tube the steam bubbles formed on the inner side and left the tube at an angle of about 35 degrees, being carried upward by the circulating water, the current of which was but a very short distance from the inner side of the tube. The water ran parallel with the outer side of the tube. There was no washing effect obtained with this tube as with the outwardly inclined tube.

With the tube representing the Wooten type of boiler (D, Fig. 1) the circulation was parallel with both the inner and outer sides until the diverging point was reached; at this point the two currents appeared to cross each other, the result of which was a very noticeable whirlpool. As the steam bubbles were formed they were carried upward by the circulation, the water and steam mingling. At all times the inner side of the tube seemed to be well covered with water. It was also easy to cause the water to boil over with this type of tube.

With the O G type of tube (E, Fig. 1) the circulation was also parallel with the inner and outer sides until the upward curve was reached; at this point the currents crossed each other and caused a whirlpool similar to that obtained in the Wooten type. A smaller whirlpool was also noticed at the lower curve with a tendency to retard the circulation at this point. It is about this point that considerable trouble is experienced with cracked side sheets with this type of firebox and this may be the cause.

By accident an incident occurred during these experiments that should convince the most skeptical. One of those looking on while the experiments were being made unfortunately could not see as well as the others, owing to his eyesight being somewhat defective, and in order that he might see what was taking place, silica was added to the water in the tubes, so that when the circulation started the silica followed the currents being formed,

and their direction could be more readily seen. This silica is precisely the same as the mud and scale forming elements in the water fed to locomotive boilers. When the water in the tubes was allowed to cool, the silica naturally precipitated in the same manner as the mud and scale forming elements would in the boiler. This precipitate clung to the tubes at exactly the same points that have been found worst for collecting mud and scale on the different shapes of water legs on locomotive boilers in actual service.

These experiments appeared to establish the soundness of Mr. Seley's theory and it seems that the best circulation is obtained with the outwardly inclined water leg. Several of the larger railroads have adopted this design during the past few years and to the best of the writer's knowledge the results obtained have been very gratifying.

#### MATERIAL.

Ordinarily, whenever trouble develops with any part of the boiler, unless the cause is very evident, the first reason assigned for it by those directly in charge is poor material or weak design, and it is up to those responsible for the material and design to get busy. For a long time the steel used in fireboxes has been either basic or acid open hearth, with a tensile strength of from 48,000 to 65,000 lbs. per sq. in., the carbon running from

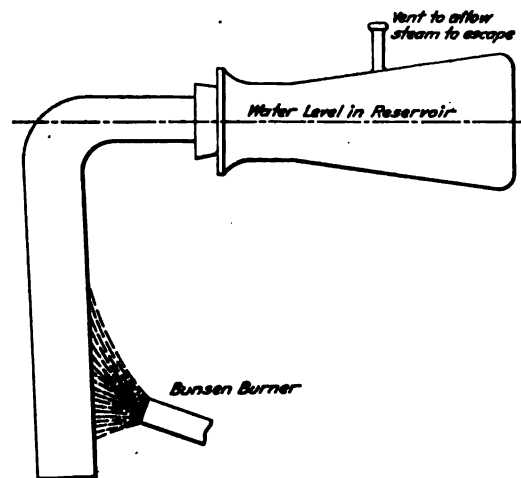

Fig. 2—Arrangement of Apparatus for Studying Circulation.

.10 per cent. to .25 per cent.; the amount of carbon is directly proportional to the tensile strength, and this grade of steel has been used in both the wide and narrow fireboxes.

It is generally agreed that the milder the steel, the better will it resist the strains imposed upon it in service. One manufacturer recommends that the tensile strength be decreased and the thickness increased proportionally so as to obtain the desired factor of safety. Of course, this is not feasible, as tests made, with which all are familiar, show that as temperature increases, strength decreases, and increasing the thickness of the side sheets will beyond doubt result in higher temperatures. It has been found from actual service results that on the majority of the railroads experiencing trouble with short life of side sheets with wide fireboxes, the trouble has been confined to a great extent to the fireboxes made in one piece, and along this line the investigation was made.

It has been previously noted that the average life of the one-piece firebox in a group of 210 engines was but 34 months. In addition to the one-piece firebox, the water leg was inwardly inclined with the result of poor circulation. On fireboxes of this type the sheets fail in a longitudinal direction, extending as high as 30 in. above the mud ring, and usually about midway between the back tube sheet and the door sheet; no horizontal cracks have ever been reported or observed.

A single sheet that will be large enough for the two sides and the crown of one of our modern locomotives must be rolled at least 192 in. x 112 in. x  $\frac{3}{8}$  in., and as our largest rolls (at the

time this investigation was made) are but 144 in. wide, the sheet must necessarily be rolled so that the longitudinal direction of rolling will be placed in the firebox transversely; the transverse direction of the rolling will naturally be in a longitudinal position.

The greatest tendency of movement of the firebox, due to expansion and contraction, is fore and aft, and with this large sheet applied to the firebox as previously stated, the greatest strains are thrown against the longitudinal direction of rolling, rather than against the transverse direction of rolling. The effect of this is simply to open the grain of the steel. This sounds rather radical, but in order to determine whether the direction of rolling had any effect on the strength to resist a vibratory movement, the following tests were made. Also, the cause for all cracks appearing in a longitudinal direction will be made apparent.

Pieces of acid, basic and nickel open hearth firebox steel were



Fig. 3—Shaper Arranged for Vibrating Test of Firebox Steel.

clamped in the vise of an ordinary shaper. The opposite ends of these pieces were clamped rigidly to the head of the shaper. The distance from the head to the vise was 14 in. and the movement of the head on either side of the center line was 11/32 in. The machine was run at the rate of 37 strokes per minute. Test pieces were held constant, as near as possible, to a temperature of 300 degrees F. by means of a Bunsen burner. One longitudinal and one transverse test piece from each kind of steel was used in the experiment. The arrangement is shown in Fig. 3.

The analyses of the different steels were as follows:

	Carbon.	Mang.	Phos.	Sul.	Nickel.
Basic .....	.17	.46	.016	.029	
Acid .....	.10	.31	.027	.029	
Nickel .....	.37				3.30

Number of vibrations before fracture:

	Transverse.	Longitudinal.
Basic .....	6,351	3,494
Acid .....	8,539	7,350
Nickel .....	15,344	12,000

From these results it will be seen that the direction of rolling

has a very decided effect on the steel as far as the strength to resist vibratory stresses is concerned; also that the nickel steel will resist a greater number of vibrations than the acid steel, while the acid steel is superior to the basic.

It has often been remarked that at times the side sheet of a locomotive boiler cracks with a report like that of a pistol; during these tests a condition was observed that will explain this. There would be no signs of a fracture on the test piece in the machine and at the next movement the piece would break with a report, not as loud, of course, as a pistol, but plainly audible. The theory for this is that the steel is able to withstand so many vibrations, and after this number has been reached it is so fatigued that it fractures suddenly with the resulting report.

Another trouble in rolling a plate of this size is that there is a much greater tendency towards variations in thickness due to the springing of the rolls. Careful measurements of a plate cracked in service showed a variation in thickness of .073 in.

A further objection to this large plate is that there is a greater tendency for variation in the carbon content and more likelihood of segregation. Chas. L. Huston in his very interesting paper before the American Society for Testing Materials in 1906 (Proceedings of the American Society for Testing Materials, Vol. 6, 1906), showed clearly the results of this variation in carbon. It was graphically shown that in an ingot such as would be required to roll a plate of the size required for one of our modern locomotives, the carbon content at the bottom of the ingot and at either edge was about .13 per cent. with a tensile strength of about 55,000 lbs., while in the center of the ingot the carbon was .18 per cent. with a tensile strength of 58,500 lbs. At the top of the ingot the carbon content at the outer edge was .14 per cent. with a tensile strength of 56,000 lbs., while in the center at the top the carbon was .22 per cent. with a tensile strength of 65,000 lbs. There was a variation in carbon of .09 per cent. and in tensile strength of 10,000 lbs.; a like condition would be obtained in the plate rolled from the ingot.

As test pieces are taken from the edges of the plate and drillings for analysis are taken from the test pieces, while the carbon content and tensile strength of these test pieces would meet specification requirements, the center of the plate would have such a carbon content and tensile strength as to cause rejection; therefore, it appears that tests made on the firebox steel in order to insure that the results show what is actually being obtained, are open to question. As the specifications used by the railroad show a minimum and maximum tensile strength and carbon content, it would be better to ask only for a minimum specification limit, as it has already been brought out that the test pieces are obtained from the edges of the plate, and it has also been shown that the center of the plate will not contain any less amount of carbon, nor any lower tensile strength. As the factors of safety used in connection with the firebox construction are figured with the minimum tensile strength, there will be no danger of reducing the factor of safety used in the design of the boiler. The writer firmly believes that in following this course much better results will be obtained in service.

Since the advent of the oxy-acetylene and electrical methods of welding, which have now passed the experimental stage, it is no longer necessary to make firebox plates in one piece to eliminate the troublesome seam at the junction of the sides and the crown. The side sheets can be ordered rolled so that they can be applied to the firebox with the longitudinal direction of rolling placed longitudinally. They can be made 5/16 in. thick, which will insure a lower temperature, and welded to a 3/8-in. crown sheet. Tests made of welds by these processes show a strength of the original plate of 80 per cent. This is an increase of 15 per cent. over the best design of riveted seam at this point.

The question of staying has not been entered into, as a poorly designed method of staying will affect the life of the firebox, whether it be wide or narrow.

Summing up, it has been shown:

1. That the outwardly inclined water leg is the most desirable as far as the circulation of the water is concerned.

2. That the direction of rolling of the sheet affects its ability to withstand the strains imposed in service and that the direction of rolling should be specified.

3. That the relative values of the different steels to withstand these strains are, first, nickel; second, acid; third, basic.

4. That the lowest specification carbon content and tensile strength requirement should be asked for and accepted.

5. That the single piece firebox as now applied is a mistake.

### REPORT ON STAMFORD COLLISION.

The Interstate Commerce Commission has issued a report by Commissioner McChord, dated July 7, on the rear collision of passenger trains which occurred on the New York, New Haven & Hartford at Stamford, Conn., June 12. The name of Mr. Belnap, inspector of the commission, appears at the head of the report as one of the advocates who appeared before the commissioner. The railroad company was represented by Benjamin I. Spock and J. F. Berry, counsel, and C. L. Bardo, general manager, and C. N. Woodward, general superintendent.

This report fills 23 pages. The facts of the accident have been given in the *Railway Age Gazette* (June 20, pages 1532, 1548 and 1549; June 27, pages 1594 and 1608) and we take from the present report only such parts of the statements of facts as will throw additional light on the cause of the collision.

The rear car of the standing train was 171 ft. west of the home signal; the distant signal was 1,800 ft. in the rear of the home, and could be seen plainly by enginemen approaching from the east a distance of 1,847 ft. Between the home and the distant there is a two-degree curve and the home signal is not visible from the distant. The grade is descending for more than a mile approaching the distant signal, maximum descent one-third of 1 per cent. Doherty testified that he shut off steam on the curve before coming within sight of the distant signal; that he made a 15 lb. reduction of air pressure 300 ft. before reaching the distant signal and, as the brakes did not seem to take hold well, that he made another reduction of 10 lbs. after passing the distant signal; that emergency application was made when within 300 ft. of the standing train.

Doherty had fired three years in passenger service, mostly on a local passenger train on the single track line between New Haven and Shelburne Falls. When he was first a candidate for promotion he failed to pass the mechanical examination, but afterwards was again examined and passed. Prior to the collision he had worked altogether 265 days as engineman; in yard service 158 days; slow freight 79 days; fast freight 10 days; passenger trains 18 days, including the two days on train No. 53.

On reporting the brakes as unsatisfactory, two days before the collision, he noticed that the man in the roundhouse had not improved things and, being not entirely satisfied, he, on the return trip to New Haven, took extra precautions in making the stops, beginning to apply brakes "way back," and securing good results. He had much difficulty in watching the water, the water glass being out of order.

Since he had been an engineman none of the traveling enginemen, who were employed for that purpose, had ever ridden on an engine with him, or given him any instructions or assistance of any kind. When he was taking his engine from the turntable preparatory to starting on the first trip to Stamford on Tuesday, June 10, Traveling Engineer Carroll asked him where he was going. He replied that he was going on second No. 53. Engineman Doherty's further testimony as to this conversation was as follows:

He said, "Well, for Christ's sake look out for yourself." He says, "Harmon got into it yesterday." He says that "the brakes ain't holding, and the water glass is out of order." Now he says, "Bardo is raising holy hell." So he says, "Start braking back far enough so as to make sure you will stop." That was the only instructions I ever got.

Doherty said he did not know at what point in Stamford

it was customary to change engines; but he had served three weeks as assistant to the engineman on electric locomotives between Stamford and New York, and during this time engines had been changed sometimes at Stamford station and sometimes at a point east of the station (as was the case on the day of the collision).

Fireman Smith, who was on the engine with Doherty on the day of the collision, was an extra fireman with about fifteen months' experience. His testimony is of little or no value.

Engineman Waite, who happened to be standing on the ground nearby at the time of the collision, examined the brake cylinders, and found one car on which the brakes were not applied; but he said that the air might have leaked out after the collision.

General Air Brake Inspector Joy was on the scene of the accident twenty minutes after it occurred. Judging by the time that the brakes continued on, he thought that they possessed good holding power. The breaking of the coupling, causing the separation of the train ahead of the Pullman car Centredale, he thought due to the emergency application of the brakes on that car while running at low speed.

The cars of Doherty's train came through from Boston over the Boston & Albany. The engineman of the train on that road, Boston to Springfield, 98 miles, said that the brakes were a little slow in operating, and that he had to make a large reduction of air before he felt the brakes take hold. The engineman who ran the train from Springfield to New Haven, 62 miles, said that the brakes were in good condition and that he had no difficulty in operating them.

Machinist Gash, inspector of locomotives at Stamford, has been a machinist for five years and has been at Stamford 10 months. When he found nothing wrong with the brakes he thought the defects noted by the engineman could not have been very serious, for, said he, if it had been serious the engineman would have told him about it. He did not remember the item in Doherty's report referring to the water glass.

At New Haven, the other end of Doherty's run, there is no book for reporting defects of engines; an engineman having anything to report must speak to the inspector. The report describes the practice of the inspectors as to examining engines and keeping records, both at New Haven and at Cedar Hill, just east of New Haven, where some of the engines are kept. Men making repairs are found to have been careless about properly recording in the books the facts concerning their work, as required by the rule. At the Cedar Hill roundhouse the record of work done was inadequate and the officers of the road had no means of knowing with precision the conditions of engines going out.

Road Foreman of Engines Carroll has held that position since August, 1912. Four road foremen of engines have supervision over about 400 enginemen. His testimony concerning his relations to Doherty agrees with what has been printed heretofore. Asked why he did not ride with Doherty on Thursday, in view of the fact that he had found it necessary to caution him, he replied that he believed he had already performed a day's work. (This was about 3 or 4 o'clock in the afternoon.) As to this the report says:

"In view of the importance of this train and in view of the fact that Carroll knew Doherty had had little experience as an engineman in fast passenger-train service, was not accustomed to the new engines, and had failed to control his train properly at one place on a trip just two days before, and also since he did not know whether or not a road foreman of engines had ever ridden over the road with Doherty, a proper sense of responsibility of his position and a proper regard for the safe operation of this train should have impelled Carroll to accompany Doherty on this trip."

The report here gives an account of the air brake tests on June 17. Seven running tests were made. In the first six the brakes were applied (service application) at a point 1,571 ft. in

the rear of the distant signal. In the sixth test the brakes were applied in emergency at the distant signal, the test being intended to reproduce the conditions under which Doherty said he had operated on the date of the collision (though the statement of Doherty's testimony indicates that he did not claim to have applied the brakes in emergency until within 300 ft. of the standing train). However, the train in all of the six tests stopped a good distance short of the home signal; but the seventh test, in which the brakes were not applied at all until the engine passed under the distant signal (at 59.6 miles an hour) the train was not stopped until it had run 496 ft. past the home signal and 325 ft. beyond the point where the collision occurred. A 10 lb. reduction was at first made; then a 5 lb. reduction and then an emergency application. The intervals of time between these different applications is not given. This seventh test was intended to reproduce the operations which the investigators supposed had been employed by Doherty on the day of the collision.

Prior to the test of the brakes the examination of the apparatus in the yard showed that piston travel was not uniform, and that on one car it was necessary to make a reduction of 20 lbs. to set the brake and on another it required between 30 and 40 lbs. This, says the report, indicated that the brake on this car would not apply except with an emergency application; and it is held that the break-in-two was probably caused by the brake on this car being set with full force by the emergency application; and it is also held that previous to that emergency application this brake probably did not hold at all.\*

The brake test made by cutting the train in two while running at high speed showed that the engine brake was very good; that is to say, the engine did not run much farther than the rear portion before stopping. The car brakes were not as good as they should have been; that is to say, with a train in first class condition there would have been a greater gap between the engine and the train after the stop.

The commission criticises the report of the air brake committee as lacking definiteness. The committee says that the brakes were in "good serviceable condition" but does not indicate just what this term means. The brakes were doubtless in serviceable condition but "it is not believed that they were in that high state of efficiency which the requirements of safety demand in fast passenger train service."

The distant signal should have been located farther back. There is no physical reason why it could not be 800 ft. farther east; and, "had it been so located there is every reason to believe that this accident would not have occurred, even though the engineman exercised poor judgment in failing to apply the brake until within a short distance of the distant signal."

Here the main body of the report ends, with a statement of conclusions like that which is repeated at the close (see below). And then it goes on to discuss the superiority of steel over wooden cars. It is declared that at the present time "it is the exception rather than the rule to find wooden cars on the fast passenger trains" of many railroads. The New Haven company has ordered 354 new steel passenger cars. Of the 236 Pullman cars in use on its lines, 24 are of steel. The report then goes on to discuss the testimony of General Manager Bardo, and to refute the statements made by him intended to relieve the management of the road and throw responsibility on the brotherhood. From this part of the report we quote as follows:

"As to the enginemen's working agreement the rule has two plain and definite exceptions: (1) 'So far as it is possible

with the requirements of the service,' and (2) 'provided they are competent.' Primarily the determination of 'the requirements of the service' and 'competency' of engineers is for the management of the railroad. In this case it is shown that no reliable or effective system was in operation for the determination of the safety requirements of the service in the selection of an engineman for a particular service or for the determination of the competency of an engineman when he was first given a high speed passenger train. The neglect of precautions for safety was here a neglect upon points which the enginemen's agreement left open to the management. The mere absence of demerit marks while in freight service was considered a good record, sufficiently determined, to justify employment on fast passenger trains, a class of service requiring the highest degree of qualification. No determination of special qualification for higher grade of service was made. The agreement with the enginemen in no manner restricts examination or competency tests on the part of the management. . . . Other railroads have rules providing safeguards in this respect. The general manager stated his belief that the trouble arose from the employees' organizations and the attitude of the public. No organization but that of the New York, New Haven & Hartford Railroad Company is responsible for placing a man in charge of this locomotive without tests by traveling engineers. . . . Something is 'out of gear' where high-class trains may be given over to an un instructed engineman. And this is true even if he is sent out on a run with the caution of his superior, 'Don't let it get away from you.' Here was doubt from the man who ought to know. It was Carroll's duty to know Doherty's capacity. . . . 'Man failure' can only excuse the railroad and its officials where the man has been properly tested and found to possess the positive qualifications required. There is no evidence which raises any doubt that for the work he had previously been engaged upon Doherty was competent, but when he was placed in charge of a new engine attached to one of the fast passenger trains some one in authority signally failed in duty. . . . It is but fair to say of the present general manager that his connection with this railroad is recent and that his efforts in the promotion of safety during the short time he has been in charge encourage the hope that he may succeed in placing it on a safer operating basis. . . . The change of power should have been at one definitely fixed place. A train running in two sections on very nearly the same time calls for special official supervision.

"The whole evidence taken in connection with the knowledge we have of the requirements of railroad service justifies the following conclusions:

"1. The engineman of second No. 53 did not have the special experience and instruction required for the operation of such a train.

"2. The railroad company had no reliable method for determining the capacity of enginemen before placing them in charge of high-speed passenger trains.

"3. There was negligence on the part of the corporation in putting in charge of such a train as second No. 53 an engineman inexperienced and un instructed for this class of work.

"4. This railroad has no proper system of checking work reports so as to determine whether or not defects reported on locomotives are actually repaired. This lack of supervision is dangerous and it ought not to be permitted to continue.

"5. The distant signal at Stamford is too near the home signal, and should be at least 2,500 feet distant therefrom.

"6. Modern steel equipment for high-speed passenger trains should be installed at the earliest possible time, as recommended in previous reports of this commission, and legislation fixing such a time should be enacted without delay.

"7. Establishment of safer and more efficient operation of this railroad is immediately necessary if congressional legislation extending the scope of governmental regulation of railroads is not to be called for and justified in the interest of public safety."

\*The report made to the railroad company by the inspectors, Messrs. Langan, Martin, Burton and Lorimer, indicates that the failure of this brake to act, when tested before the train was started out for the experiments, was due to the fact that the reservoirs had not been fully charged; that the test was made too soon after the engineman began to charge the train. This particular car had water-raising reservoirs and two brake reservoirs, the only car in the train that was thus fitted. The failure of the brake to operate occasioned no comment among the air brake men who were present. The members of the committee have no doubt that this car was fully charged at the time of the collision, and that, therefore, it operated the same as the other cars at that time.—EDITOR.

## STATEMENTS BY THE RAILROAD COMPANY.

The railroad company issued a reply to the commission's report in which is the statement that "the report fails to state that the employment of this engineer was practically forced upon the New Haven Railroad by the engineers of the company." The agreement provided . . . that "Spare engineers shall be run first in and out so far as it is possible with the requirements of the service and, when engineers are assigned to temporary vacancies, they shall remain on same provided they are competent until the regular engineer returns." In the fall of 1912 an order was issued to the effect that spare engineers who had less than two years' experience, or two years' rating as engineers, would not be allowed to run through passenger trains. This order was protested by the engineers on the ground that the company had not adhered to the rule of giving the engineers thirty days' notice before amending existing rules. The company then issued the thirty days' notice, and when this time was up C. L. Bardo was general manager, having been appointed in the interim. The statement continues: "The engineers of the company, as was the case with all the eastern railroads, had been in an unsettled state of mind owing to the arbitration of the wage question, and Mr. Bardo, realizing this, and the engineers still protesting, asked the engineers to propose a counter ruling. The engineers offered the rule which is now in effect, which provides instead of two years' experience a requirement of one year's experience. Mr. Bardo accepted this amendment because it was essential to public safety that the engineers should get back to work without having another long dispute to settle with the company. Furthermore, not a single case could be found where the young engineers had been the cause of any trouble whatsoever. . . Mr. Doherty had an excellent record. The company had no way of telling that he was incompetent. . ."

General Manager Bardo later issued another statement, saying that the company was carrying out the recommendations made by the Interstate Commerce Commission in connection with all of the three accidents—Bridgeport, Westport and Stamford.

### RAILWAY GENERAL FOREMEN'S ASSOCIATION.

The ninth annual convention of the International Railway General Foremen's Association opened at the Hotel Sherman, Chicago, Tuesday, July 15. F. C. Pickard, master mechanic of the Delaware, Lackawanna & Western at Buffalo, N. Y., presided. The invocation was made by Right Reverend Bishop Fallows. The association was welcomed to the city by Leon Hornstein, assistant city attorney, and response was made to the address of welcome by W. T. Gale, machine shop foreman of the Chicago & North Western.

## PRESIDENT'S ADDRESS.

President Pickard called attention to the necessity of the members carefully examining the exhibits, the sessions being restricted to the morning in order to give them an opportunity for so doing. He spoke of the valuable work done by the various technical journals in promoting shop efficiency and in assisting the organization in its work. The members were urged to thoroughly discuss the subjects on the program so that all might be benefited by the experiences of others, this being of utmost importance to derive the greatest benefit from the association.

All general foremen should be able to make an analysis of the local conditions, and surround themselves with the proper organization to meet the requirements of shop management. Organization is recognized as an economical necessity to effective control and co-operation in human effort. Organization deals with men and industrial organization includes the elements of production and transportation. He laid special stress on the conclusions reached by the association, emphasizing the fact that they should be carefully considered and seriously deliberated upon. The association should be sure it is right and then carry

out its convictions to the end. Promotions are attained by actively promoting the welfare of their companies. The men doing big things today are those who were yesterday doing the little things the best they knew how.

## MR. QUAYLE'S ADDRESS.

Robert Quayle, superintendent motive power and machinery of the Chicago & North Western, made an address in which he further emphasized the last part of the president's address concerning men who are doing big things today; they did the small ones yesterday and did them to the best of their ability. This he designated as one of the keynotes of success. He strongly favored the idea of such men as the general foremen getting together and exchanging ideas, stating that if each man would give to the convention some of his special kinks, those attending the association would have enough ideas to keep them busy for the rest of the year. Intelligent hard work is a great deal more important than geniuses. Each man should make an inventory of his accomplishments and character to see how much advance he has made throughout the year. Railway men must be progressive and try to constantly improve conditions. Men should do their work for the love of it, and have the desire of accomplishing things, and promotions will come automatically. Each man should obtain as his assistants men who are as good or even better than he is, so that when opportunity comes for a promotion there will be somebody capable of taking his place. Study the men under you, and get them to work with you. Push your men along to the front, giving them all the help you can, and they will become staunch friends and their conscientious assistance will boost you also. Have your work done with the minimum amount of effort. Have the tools in your shops located in a progressive sequence and always keep alive, infusing energy into the men under you. Above all things, such men as general foremen should have good, strong characters by which they can win the confidence both of the men under them and of their superiors, which in the long run will produce the results desired. President Pickard responded to Mr. Quayle.

*Secretary-Treasurer's Report.*—The secretary-treasurer's report showed a total of 214 members and a cash balance of \$620. No technical reports were presented on Tuesday, the opening day of the convention.

## SUPERHEATER LOCOMOTIVES.

P. C. Linck, general foreman of the Chicago & Eastern Illinois, Danville, Ill., presented a complete and interesting paper on the care and maintenance of locomotive superheaters. He mentioned as one of the most important items in keeping superheater locomotives in successful operation the necessity of having the flues and superheater units clean at all times. One man should be appointed to see that this work is done, and he should be held strictly accountable for it. Superheaters should be given a warm water test of about 100 lbs. approximately every month, and should be carefully examined for leaks or cracks in the header and in the unit pipes just below the ball joint. Trouble has also been experienced with the return bends leaking at the firebox end.

On the Chicago & Eastern Illinois it has been found necessary to use the best quality of cast iron for valve bushings, valve packing and cylinder packing on superheater engines, as otherwise they will give considerable trouble due to excessive wear. That road has experimented with a composition metal made of copper, lead, tin, zinc and antimony applied to the bottom of the piston head to reduce the wear. This application has been in use for six months and is still giving good service.

In regard to the lubrication, it is advised that the oil be admitted to the steam pipes far enough away from the valve to insure its becoming thoroughly atomized. In some cases it has been found necessary to admit the oil in the steam pipe on the inside of the smokebox; the oil pipe being entered through the side of the smokebox. Boosters have been found satisfactory in forcing the oil into the steam pipes. It has

been found that with an ordinary lubricator it takes 10 or 15 minutes for the oil to reach the end of the pipe, and for this reason the lubricator should be started before the throttle of the engine is open, and should give a small but a constant supply of oil. On a balanced compound locomotive equipped with a superheater it was found necessary to admit the oil to the steam pipe further from the cylinder than is ordinarily done on simple engines.

In some places it is the practice to splice unit pipes, broken just below the ball joint, with a steel coupling. Recently acetylene has been successfully used in repairing the return bends of the unit pipes at the firebox end. Unit pipes, 18 ft. or longer, should have two supports in the large flues; the first one 6 in. from the back end, and the second midway between the first and the end of the straight portion of the unit. It has been found that unit pipe ball joints made of copper give the best service.

When welding a large superheater tube care should be taken that it is uniformly supported in the welding machine and furnace. It has been found expedient to provide peep holes in the side of the smoke arch to allow for inspecting the front end, flue sheet, superheater and ball joint connections, so that the baffle plates will not have to be removed. These plates should have a tight fit and should be so constructed that they can be taken from the front end without removing the door ring. While on the road superheater engines should not carry more than two gages of water when working on level track, and the throttle should always be slightly cracked when drifting so that the steam may carry the oil to the valves and cylinders. It has been found that with the ordinary oil about 25 per cent. more should be used on a superheater locomotive than on a saturated locomotive of the same size and in the same service. In running, the full throttle is recommended wherever it is possible.

*Discussion.*—Extension piston rods greatly reduce the wear of pistons. Graphite used in correct proportions aids lubrication considerably. The superheater header should be bolted to the smoke arch. The combustion chamber on the Central of Georgia, together with the brick arch, reduces the plugging up of flues. The oil pipes should be direct with no pockets, and it is good practice to anneal them at general shoppings to prevent breakages. The oil should be thoroughly atomized. Pyrometers applied to superheater engines give good indication of operation. When converting a saturated steam engine to a superheater a small injector should be applied so as to feed water continuously without flooding the boiler. The greatest problem of superheaters is their maintenance at the engine house. Clean flues are an absolute necessity. The keeping in stock of superheater spare parts was strongly recommended. The subject was very thoroughly discussed and much valuable information was developed concerning the maintenance of superheater locomotives.

**COAL TRAFFIC IN INDIA.**—From a report just issued, it appears that the total output of the Indian coal mines in 1912 was, in round numbers, 14,000,000 tons, of which about 13,000,000 tons are obtained from Bengal coalfields. The East Indian Railway has, in one week alone (week ending May 24 last), moved about 23,000 carloads, which constitutes a record. If this state of traffic continues, one can safely predict that about 11,000,000 tons of coal will have been put on the rails on this one line alone during the year, in spite of the complaints of the colliery-owners on the score of inadequacy of rolling stock. One of the difficulties experienced by the East Indian Railway in dealing with the coal traffic to Calcutta is due to the handling of trains between Burdwan and Bande Junction. There are 20 passenger trains each way daily on this section, and the coal trains have necessarily to be sidetracked to make way for these. Hence there is frequent congestion, though the track is a double one. The remedy seems to be the laying of a third track.

## THE FREIGHT CLAIM ASSOCIATION.

The twenty-second annual meeting of The Freight Claim Association was held at Bluff Point, N. Y., June 18, with President F. E. Shallenberger (Star Union Line) in the chair and 170 members and proxies present. President L. F. Loree, of the Delaware & Hudson, delivered an address of welcome. President Shallenberger in his address dwelt on the work which had been accomplished during the year just ended, calling particular attention to the successful labors of the Conference Committee and its sub-committee with the representatives of the Interstate Commerce Commission and to the fact that this work had been carried on in a spirit of cordial co-operation. Reports from the Conference Committee and the committees on Constitution and By-Laws, Loss and Damage Rules, Overcharge Rules and Methods and Topics were considered, also the report from the special committee appointed to confer with a similar committee of the Association of American Railway Accounting Officers.

The Conference Committee reported that through its sub-committee, working in conjunction with Messrs. Lutz and Heiss, representing the Interstate Commerce Commission, a recodification of the loss and damage and the overcharge rules and rulings of the association had been prepared and recommended to the standing committee at their annual meeting for adoption by the association, the proposed recodification providing for only one set of rules (instead of two, in addition to the rulings, as at present) and working into the rules, as well as the constitution, all of the rulings except those dealing with matters of a general nature. This suggestion was accepted by the standing committees and their several reports to the association so read and were accompanied to the members of the association prior to the annual session by an appendix to the "call" setting forth in parallel form the present and proposed rules, also the changes proposed by the committees worked into the wording of the present rules and translated into that of the recodification. This plan of recodification was adopted without a dissenting vote, its use, with the new rule numbers, to become operative on September 1, 1913.

The work of the Conference Committee has reached a point where it is in an attitude of waiting upon the Interstate Commerce Commission for advice to enable it to complete its labors. Loss and Damage Rules 27 and 28, covering disposition of uncollectible freight charges, constitute one of the matters pending. It was felt that the association should be proud of the fact that its conferences with the commission had resulted so favorably.

President Shallenberger had received from Commissioner James S. Harlan a letter expressing great satisfaction with the work accomplished in the conferences during the past year. "The meetings between your representatives and the representatives of the Commission have conducted to a better understanding of the problems before us, and it is much to be hoped that our joint endeavors during the past months may be brought to a satisfactory conclusion at your meeting this week through the formal action of your association.

"The Commission has been called upon by committees of the Senate and House for an expression of views in relation to certain legislation looking to the regulation of the matter of claims against railroads. In several of these bills provisions are incorporated providing drastic penalties for the failure or refusal of a carrier to settle a claim within a definite period. In one instance the time limit of 90 days is provided. When these bills came before us I expressed somewhat urgently the hope that the Commission would advise the committees of the two houses that this is not an opportune time for the enactment of such laws, in view of the progress of our conferences with the Freight Claim Association touching the same matter. In our discussion of these questions I assumed the responsibility of giving to the Commission the assurance that the amended rules and regulations and forms growing out of our conferences would

result in the more expeditious adjustment of claims, and while safeguarding the reasonable rights of the claimants under the law would also safeguard the law itself in large measure. The Commission, accepting my view of the matter, reported to Congress, as I have said, that it regarded legislation on those questions as unnecessary at this time. I mention this matter because I wish your association to understand how definitely the Commission relies upon your association to lay before us for approval a system of rules and regulations that will reasonably accomplish the object of the proposed legislation, and also that you may fully understand the interest that the Commission is taking in the matter.

"Conference Ruling No. 15 entails some embarrassment upon carriers. Personally I am in favor of the plan of direct investigation, and I think the Commission will approve any suggestion from your association along that line, so long as it upholds the general principle that Conference Ruling No. 15 was intended to protect. . . . Original claim papers ought to be retained in the office of the carrier that pays the claim, so that they may there be accessible to our examiners.

"The matter of claims for concealed loss and damage and the disadvantageous position in which carriers are placed by the designs of unscrupulous shippers and consignees presenting such claims has had some consideration by the Commission during the past winter. If the courts at the instance of the Commission will impose severe and drastic penalties in a few such cases it will go far toward the elimination of such efforts to defraud the law and the carriers.

"You have doubtless observed that the Commission has recently restated its views in respect of the matter of interest on claims. It may be that the revised ruling is not altogether satisfactory. If that is the view of your association I invite a full expression from you. . . ."

The Conference Committee was continued for the year 1913-14, with the same objects and powers as heretofore. The Constitution was amended by providing for a fifth standing committee, to consist of five members, all to be appointed each year, and to be known as the "Committee on Accounts," to handle matters of joint interest with the committee of the Accounting Officers' Association.

The reports of the Loss and Damage and the Overcharge Committees dealt, to a large extent, with technical changes in the rules proposed by members and some slight amendments were made in several of them.

John S. Donaldson, assistant comptroller, Pennsylvania Railroad; Moultrie Hitt, secretary of the General Managers' Association of the Southeast, and C. W. Crawford, assistant to the general agent of the American Railway Association, addressed the meeting on matters of mutual and timely interest.

The special committee for conference with the committee of the Accounting Officers' Association joined the Accounting Officers' Committee in recommending a form of astray freight interline way-bill, which recommendation the Association concurred in.

It was decided to continue the publication of the Appeal Decisions, inasmuch as the secretary's report showed that during the past year there had been a falling off of about 25 per cent. in the claims submitted for arbitration, which was believed to be the result of these publications. With the use of the new code of rules, September 1, with an entirely new set of rule numbers, it will be important to have in published form awards of the appeal committee rendered in accordance with such recodification.

The secretary reported 401 members, representing 260,270 miles of rail lines, in addition to the mileage of the steamship members, in the United States, Canada and Mexico, there having been 27 new members added during the year. The financial affairs of the association were also reported in good shape with a balance in bank.

The following officers were elected for the ensuing year: President, George W. Perry (Great Northern); first vice-

president, J. W. Newell (Chicago, Burlington & Quincy); second vice-president, E. Arnold (Grand Trunk); secretary and treasurer, Warren P. Taylor, Richmond, Fredericksburg & Potomac, Richmond, Va.

It was decided to hold the next annual meeting at Galveston, Texas, May 20, 1914.

## MARK STEEL UNION.

A cold drawn steel union has recently been placed on the market by the Mark Manufacturing Company, Chicago. Cold drawn steel is used throughout its construction, and its coefficient of expansion is the same as that of the iron or steel pipe to which it is attached. This allows the union to expand in the same ratio as the rest of the pipe, which will tend to reduce leakage. Being made of cold drawn steel it will be free from the usual defects found in many cast unions. It will also have the additional strength inherent in cold drawn steel

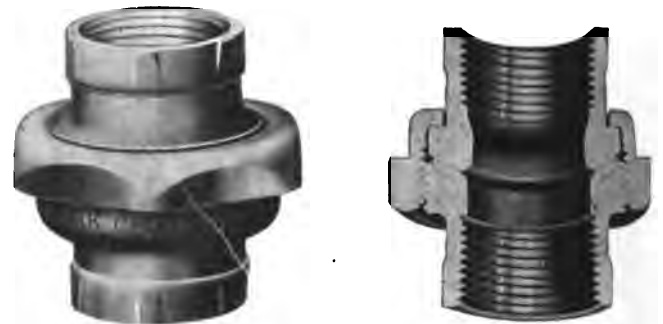

Mark Cold Drawn Steel Union.

products. The various parts are made from flat sheet steel, and the process of manufacture of one of the members is shown in one of the illustrations. Discs are cut from flat strips of steel and drawn to deep cups from which the bottoms are punched. One end of the tube is then folded or rolled back on itself to form a reinforcement and later is pressed to its final shape, making a densified, hard steel seat. The lower end is then upset. The brass seat ring is also drawn cold from flat soft stock and annealed after drawing to keep it soft. Both the steel seat and brass ring are formed in dies and do not require machining or grinding.

The union is thoroughly sherardized after the threads have



Various Steps in the Manufacture of Mark Cold Drawn Steel Unions.

been cut, which will prevent corrosion. It is threaded to the Briggs standard for pipe threads and has the same taper as that of the pipe. Being made of steel it has the additional advantage of not retaining a permanent set when being tightly drawn up. This feature will insure the long life of the union and will eliminate the necessity of re-tightening it after being subjected to heavy pressures.

# Maintenance of Way Section.

THE attitude of the railways with reference to the future source of their tie supply stands out in marked contrast to the foresight shown in many of their large development plans. Comparatively few roads are making any attempt to provide beyond their immediate needs, and one purchasing officer of a prominent road stated, within the last few weeks, that his road had less than a month's supply of ties on hand. The last annual report of a large eastern road using over 1,000,000 ties annually and located close to the source of tie supply, showed that the cost of ties had risen from \$0.44 in 1903 to \$0.70 in 1912—an increase of 59 per cent. in 10 years. Upon the basis of the 1912 requirements the item of ties alone represented an increase in expenditure of a half million dollars in ten years. These figures would seem to show the advisability of a careful study of the future tie supply, for, rather than decline, this rate of increase bids fair to climb still faster.

THE opinion of railway men as to the value of cinders has been gradually changing until now many regard them as worse than valueless. In former years they were widely used as ballast on branch lines, but in many instances the practice has been discontinued, and they have come to be considered suitable only for filling in land for future development. However, careful study will frequently reveal ways in which cinders can be utilized profitably. Nearly every railway, not only in the West, but also in the East, has a considerable mileage of branch lines with mud ballast, or ballast little better than this, where cinders would be a great improvement. The practice of one western road could be profitably followed in many such cases. As the cinders have to be loaded on cars at the cinder pits for removal, this road loads them either in standard drop bottom cars which would otherwise return empty. These cars are hauled out to branch lines in the direction of the car movement, and are then taken out onto the branches by way freights and quickly unloaded. It has been found that by carefully making out a program in advance and working to it, it is possible completely to ballast a considerable mileage of branch line track with cinders each year at a cost very little above that of the actual labor of putting the cinders under the track.

THE floods throughout the Ohio valley the last week in March presented problems of unusual magnitude to track and bridge men alike. All lines within the flooded area were affected so that no relief was possible from other lines in the immediate vicinity. In many instances superintendents and other local officers were completely cut off from communication with their superiors or with the outside world. With bridges gone, embankments washed out, and supplies and reconstruction equipment unavailable, the problem presented was most serious and difficult. The only essential element present in sufficient quantity was labor. The way in which these lines were restored to operation under these highly adverse conditions is very creditable to all in charge and is at the same time instructive to other railway men. The description of the measures adopted on the Baltimore & Ohio in another column is of special interest, as it is the first article of such nature published. The description of the means adopted to hold piles in the swift current by scows, cables, etc., and of the methods used in dragging track back onto embankments is especially interesting and valuable.

TWO criticisms frequently made regarding college graduates in maintenance work are that they do not appreciate the importance of the small details making up a large part of the routine work, and that they do not know how to handle men. It must be admitted that in many instances these criticisms are well founded. To improve this condition, attempts have been

made at various times on the Big Four, Illinois Central and several other roads to employ college graduates as track apprentices in regular gangs or in similar positions where they are given opportunity to learn the fundamental details of maintenance work. These plans have failed from one cause or another. The co-operative courses at the University of Cincinnati are directed toward the same end. While these courses have proved very successful in industrial plants, they have not yet been tried enough in railway work to enable conclusive results to be secured, but the roads on which the students following them have been employed are highly pleased. The success of any such plan depends not only on the proper education of the student but also on the co-operation of the railways in making the positions sufficiently attractive financially to hold the men after they have left school and until they have become capable of filling more responsible positions in the service. By failing to attract and hold many good men many earlier plans have failed. Doubtless this has been due as much to improper administration of the plans as to the unfitness of the candidates themselves.

THE method adopted by the Burlington of concentrating the operation and repair of all of its construction equipment, including steam shovels, ditchers, cars, etc., under the supervision of one man, as described in another column, has several advantages. This one man is sure to become more familiar than anybody else with the possibilities of the equipment and crews and, therefore, more able to determine intelligently when proper results are secured. He can thus detect any work that falls below standard and concentrate his attention on it until it is brought up to what it should be. If these matters are left to the local divisional officers, as is the practice on many roads, opinions as to what are satisfactory results may be almost as numerous as the officers themselves. The plan described also enables the equipment and crews to be distributed to the best advantage and with the least lost motion. Without it the cost of surplus equipment which will be purchased and of the time that will be lost on individual jobs from lack of proper equipment may reach large sums. An arrangement such as this also relieves the division superintendents of many details connected with the organization for small pieces of work which they would otherwise have to handle. A very important advantage is in the more thorough repair work possible. When the shovels are overhauled in local division shops by regular machinists unfamiliar with such work and taking little interest in it, as is often the practice, individual responsibility is largely lost and the work is not done to a high standard, with the result that the danger of breakdowns is increased, and the expense of such breakdowns mounts very rapidly when work trains and men are thereby rendered idle.

WHILE the buying of large steam shovels and other heavy construction equipment is largely dependent on the policy of each railway with reference to contracting betterment work, the purchase of small equipment is justified because of its effect in reducing the amount of labor otherwise necessary; for while much of the heavier work can be contracted for if a road is so disposed, there is a very large amount of work divided into small units which it is difficult to contract for at a satisfactory price in dull seasons and which contractors will not bid on in busy years when larger pieces of work are available. This forces the railways to do much minor grading and bridge work with their own forces and affords a field for the economical use of small equipment that is not generally appreciated. In many instances a job of concreting too small to warrant the use of a large mixer is done by hand labor when a small portable mixer would do the work more economically. Similarly, much



work, such as the extension of yard tracks and the filling of trestles, is done by teams or with a long train haul, because it is not large enough to justify the cutting in of a large steam shovel with work train, when a small shovel and dump cars would perhaps take a little longer but would do the work more economically. Small equipment of other types can also be used in many cases to equal advantage. The smaller units of construction equipment which have been developed largely within the past few years are capable of a wide range of application in railway work, and will prove economical in many cases in replacing hand labor. This equipment does not interfere in any way with the use of larger equipment on other work, but has a field distinctly its own.

#### MOTOR CARS.

AS indicated by the records of service made by motor cars in the maintenance of way department, published in this issue, there is no longer reason to question the possibility of effecting material economies by the use of these cars under normal conditions. The practically universal approval reported by all roads which have used them shows that they are a success. At the same time, the conditions under which motor cars are operated must be carefully studied in order to secure the most satisfactory results. The same savings will not be effected by their installation on multiple track main lines, where the sections are but two or three miles long, as on double track lines with six or seven-mile sections, or on light traffic branch lines with sections 10 or perhaps 12 miles long. The installation of cars must also be carefully considered on those lines of heavy curvature where there is great danger of their being struck by trains. As a general rule the longer the sections and the lighter the traffic the greater are the economies possible.

In equipping a line with motor cars, care must also be taken that the sections are not lengthened beyond the economical limit. In some cases motor cars have failed to show savings when the fault has been not in the car but in the attempt to extend the sections over too much territory. Many roadmasters have opposed their adoption even when they were convinced that they were economical in themselves because they have seen the size of gangs reduced on other lines and attempts made to cover too much territory, with the result that the standards of maintenance were lowered. Some men claim that no laborers should be dispensed with when motor cars are adopted, but that economy should be effected by extending the jurisdiction of the foremen over longer sections, thus dispensing with a certain number of foremen.

In general, there are two methods of justifying expenditure for motor cars. One is to determine the decrease in the amount of time spent by the gangs in going to and from work and to compute the wages of all the gangs for the time saved as the saving attributable to motor cars. The other method is to assume that the gain from reducing the time the men are on the road takes the form, not of actual reduction of expenditures, but merely of increase of the time that the men are actually engaged in useful labor, and therefore computes the saving of expenditure made only on the basis of the number of employees eliminated. If the cost of motor cars can be justified on this latter basis alone, as is being done on a number of railroads, the added advantage of the increased amount of useful labor done by each gang will be a clear gain in the form of better maintenance.

A few of the most important points to be considered when making a complete study of motor cars with a view to recommending the type of car best adapted for the conditions existing on any particular road are mentioned in the tabulation published elsewhere in this issue. Aside from these, one must consider whether the water cooled or air cooled engine is best adapted to his service. This will depend largely on whether the car is wanted for long continued running, as in inspection service, or for intermittent travel for short distances, as in section work.

There must also be considered the amount of power required, which determines the number of cylinders and whether the drive should be direct connected or friction. The closer these and other details are studied on the basis of the service desired the more intelligently can one select the car best fitted for his work. Several roads are conducting very careful tests and keeping accurate records of the results secured by motor cars of various types. The results of these experiments will do much to establish definitely the advantages of the different types for special work. Cars bought as the result of this information should show even greater economies than have those which have been used up to this time, although the results already secured show that the motor car is here to stay.

#### THE EFFECT OF THE FISCAL YEAR UPON MAINTENANCE.

THE advantages of starting the season's maintenance work early in the spring have been frequently commented on in these columns. The principal obstacle to the adoption of such a plan is that the fiscal year closes in the middle of the natural season for maintenance work. The more prosperous roads very largely disregard the fiscal year in making appropriations for new work or for repairs. Roads not so fortunate financially, and there are many, find it necessary to curtail expenditures in the spring year after year to make satisfactory showings of net earnings and thereby maintain their credit. To the executive officers of these roads, June 30 is a very important date. No one acquainted with the conditions will maintain that the policy of deferring maintenance work until the middle of the summer is an economical one, and while theoretically it does not appear to be advisable from any standpoint to sacrifice real economy to make a "paper showing," the pressure of the financial interests frequently makes this necessary. Poor earnings mean poor credit, and poor credit means increased cost of money. The extent to which this affects the operation and financing of our railways is illustrated by the policy recently adopted in the rebuilding of a large road. The first year the new management had control liberal appropriations were made for the improvement of track and bridges, the extension of passing tracks, etc., to handle an increased business. The following year expenditures were reduced almost to the minimum, and every attempt was made to increase the net earnings, in order to establish a credit and enable other improvements to be financed at a more reasonable rate.

The important influence of the fiscal year upon expenditures for maintenance and the serious disadvantages resulting from deferring the starting of work until July 1 seem to afford a strong argument for changing the railway fiscal year to end December 31 instead of June 30. Officers in charge of maintenance and construction work, who are those most directly affected by the present system, can well afford to individually emphasize the importance of this change to their managements or collectively bring it before the railways through the proper organization. Aside from the actual economy of properly distributing work throughout the season, an element of increasing perplexity is the growing scarcity of labor, which requires that the supply available be utilized to the best advantage. This means that instead of allowing a large part of the labor to remain idle during the early months, or to drift into other lines of work, it should be placed at work as early in the spring as weather conditions will permit, for it is most certainly true that "the early road catches the hobo." The advantages and large economies that would result from a change in the fiscal year whereby appropriations for the season's work would be made available early in the spring instead of at midsummer or in the fall, as is now frequently the case, are evident. That this is not impractical under present conditions is shown by the fact that at least two of the largest systems of the country, the Pennsylvania and the New York Central, operate with the fiscal year ending with the calendar year.

# INCLUDING \$R PURPOSES

TERS.

Cost repairs and method keeping cars.	Cost fuel per month or per 100 miles.	Do you secure greater efficiency from your labor? Yes.	Remarks.
.....	.....	Yes. Men are in better condition to work after riding motor car to point where work is to be done. Can get to work quicker and remain longer.	22 per cent. more efficiency in men and 17 per cent. less expense for maintenance of cars. Signal maintainers, roadmasters and general foremen are able to make quicker, closer and more detailed inspection. Greatest disadvantage is foremen do not understand cars and trouble is experienced.
at \$1 for light and \$2 for heavy	About 2 gal. light and 2 1/2 gal. heavy	Very much greater efficiency and longer hours on the work.	Disadvantage is danger from trains. Motor cars help hold labor and keep the men more contented.







# MOTOR CARS FOR MAINTENANCE OF WAY FORCES.

A Study of the Service of Over Thirty-five Hundred Cars  
on Sixty Roads. General Satisfaction Where Properly Used.

[WITH AN INSET.]

The use of motor cars in the maintenance of way department has spread so rapidly in the last two years that it is felt that a summary of the results being secured with these cars at present will be of even greater interest than was the similar resume which was published in the *Railway Age Gazette* of May 19, 1911. In compiling the first table, inquiries were sent to all roads over 500 miles in length. The replies which were received from practically all these roads showed 31 that were using motor cars for section and bridge gangs, or for inspection service in the maintenance department. Inquiries were sent out this year to a larger number of roads, and while it is certain that the replies do not cover all roads using motor cars, it is probable that the 48 replies tabulated in the accompanying table include those which have had the longest and most general experience with such cars. In addition to these 48 roads, replies were received from 15 others on which some motor cars are in service but which, for various reasons, could not furnish the complete data requested.

Among the latter the Canadian Pacific has two section cars in use for experimental purposes and reports that they operate very satisfactorily in the summer, but with some difficulty during the extreme cold weather. The Chicago & Alton is experimenting with 10 section cars, but has not had them in service long enough to report the cost of repairs and operation and the resulting economy to be secured from their use. The Chicago, Burlington & Quincy also has a number of cars in service, but has not collected complete data. The Chicago, Rock Island & Pacific, which was shown in the earlier table as having 116 cars in service, has even a larger number in use at present, and this company is making elaborate experiments on cars of various makes. These tests are not yet complete, however. The El Paso & Southwestern is experimenting with section cars and is increasing the section lengths on the Tucson extension to 15 miles. This experiment is just beginning and no data is yet available. The only use of motor cars on the Grand Trunk is for periodical bridge inspection. The Illinois Central is known to be making a very careful study of motor cars and has many already in use but until a final report on the present experiments is made no information is available. The Kansas City Southern has one section car and two roadmasters' inspection cars, but no cost data has been kept. The Maine Central has one car.

The Pennsylvania Railroad is experimenting with motor cars for section gangs and other maintenance forces, but has not yet collected sufficient data to reach a conclusion. The Philadelphia & Reading has in use a few cars for its signal supervisors but reports that they have not been found very good for general use on that line. The Queen & Crescent has 30 cars, most of which have been in use a comparatively short time and there has been no opportunity to compile reliable data covering their service. The Rutland has two inspection cars which have been in service 11 and 13 years, respectively. No cost data has been kept. The Seaboard Air Line, which reported 30 section cars and 20 inspection cars in use in 1911, replies that this number has not been increased since that time and that very little can be added to their former report. The conclusions reached by this road are very favorable to the use of motor cars both in section and inspection service. The St. Louis Southwestern has made use of motor cars only for inspection by superintendents. The Virginian is just starting experiments with motor cars for section forces.

The total number of cars covered in the new table is 3,306, excluding over 200 cars referred to above, as compared with

<sup>1,506</sup>  
~~1,536~~ shown in the previous compilation. While these figures are by no means complete, they furnish a good indication of the extent to which these cars have been adopted in the last two years. While, in comparing individual roads in the two tables, a number of apparent decreases are shown, it is doubtful if any of these are real. For instance, although the Santa Fe only shows 95 cars this year as against 174 in 1911, it should be noted that this year's report covers only the western lines as the data on other parts of the system was not available. The New York Central & Hudson River was shown in the 1911 table as having 149 cars in use. This should have been the New York Central system, however, and while the New York Central & Hudson River reports only 68 this year, the Pittsburgh & Lake Erie with nine, the Lake Shore & Michigan Southern with 134, the Lake Erie & Western with 27, and the Cleveland, Cincinnati, Chicago & St. Louis with 57, bring the total for the system up to 295. Somewhat similar confusion exists in the two reports for the Harriman lines. In 1911 the Union Pacific-Southern Pacific are shown as having 238 cars, while the separate reports for these two roads in this year's table show only 102 cars. However, the former report covered the entire system. Including the Oregon-Washington Railroad and Navigation Company and the Sunset lines in the present report the total is 216. This is still less than the 1911 figure, which is probably explained by the fact that reports were not received from some of the other lines of the system which were included in the general report in 1911.

Some of the most important increases in the number of cars in use are the following: The Chicago & North Western now has a total of 349 cars, and none were reported by this road in 1911. The table shows by the length of time these cars have been in service that with the exception of the inspection cars, almost all of them have been secured since the publication of the former article. The Chicago Great Western shows an increase from 77 to 196; the Chicago, Milwaukee and St. Paul from 316 to 554, the Erie from 31 to 113; and the Great Northern from 52 to 312. The Missouri Pacific, which was not reported in 1911, now has 363 cars, of which only 52 have been in service two years or more, as shown by the detailed report. The Northern Pacific presents a similar case, reporting this year 181 cars, of which only a few were in service in 1911.

There is no longer any question as to the value of motor cars in the maintenance of way department. Practically every road using them reports some economy resulting from their use, the amount and character of the savings depending somewhat on local conditions. The replies received to the 1913 inquiries do not bring out many advantages not mentioned in 1911, but it is noticeable that a much more widely extended use of these cars has not brought out any important disadvantages, and all of the advantages mentioned in the 1911 returns are repeated and emphasized this year.

In brief, the arguments in favor of motor cars in section service are that the men arrive at the work without the fatigue due to pumping a hand car and can spend the whole day working on the track. Gangs can be combined more quickly in case of emergencies. Men can be more easily secured and held in section work when motor cars are provided. On account of the saving in time and energy, the length of sections can be increased, although the tendency in this regard has been to carry such increases beyond the economical limit. Most roads are realizing that the saving resulting from the use of motor cars for section forces should be mainly in supervision rather than in labor. Sections may be combined so as to give foremen in-

creased territory with larger gangs, dispensing with the remaining foremen, but many men believe that the number of laborers per mile should remain the same in order to keep up the standard of maintenance. One road recommends limiting the length of sections to eight miles on main lines and 12 miles on branches, although these lengths are based on the local conditions existing on that road and could not be universally adopted. The Baltimore & Ohio figures that a saving amounting to \$101.42 per year is necessary to make it economical to substitute a motor car costing \$200 for a hand car whose first cost is \$25. The comparative capitalized cost of the two is estimated as follows:

	Motor Cars.	Hand Cars.
First cost of cars.....	\$200.00	\$25.00
Life of cars.....	6 yr.	5 yr.
Interest on first cost of 5 per cent...	10.00	1.25
Annuity for depreciation at 5 per cent.	20.94	4.52
<b>Operation:</b>		
Gasolene at \$0.15.....	\$49.35	
Oil at \$0.50.....	9.50	
Batteries at \$0.20.....	8.40	
Repairs.....	12.00	
<b>Total .....</b>	<b>\$79.25</b>	<b>3.00</b>
<b>Annual cost .....</b>	<b>\$110.19</b>	<b>8.77</b>
	<b>8.77</b>	
	<b>\$101.42</b>	

For bridge gangs, motor cars save much time which would otherwise be wasted in waiting for local freights to move the gang from one job to another. Several roads also mention the saving in train service which is effected by distributing bridge material on motor cars.

A power car is almost a necessity for block signal maintainers, for since the signals are widely separated and the stop at each location is comparatively short, most of the time is spent on the road going from one signal to another. This situation has even led many maintainers on roads that do not furnish motor cars to buy their own cars. Some roads report that in addition to the saving in time of the men resulting in an in-

class is so different that averages of the cost of fuel and repairs are only generally indicative of these costs and cannot be considered as exact. The following table shows the minimum, average and maximum values of the cost of fuel and repairs per hundred miles and per month for each class of service reported in the table:

Section	FUEL.			REPAIRS.		
	Min.	Av.	Max.	Min.	Av.	Max.
Section .....	\$0.40	1.10	4.00	\$0.88	1.04	1.25
Bridge .....	0.25	1.20	4.00	1.00	1.60	2.21
Maintainers .....	0.17	0.45	.90			
Inspection .....	0.24	1.07	4.00	0.35	0.91	1.95
Miscellaneous .....	0.11	1.16	4.00			

It must be remembered that a section car for example, may mean a low power car capable of carrying four to six men over light grades, or it may be one that handles 15 to 20 men on heavy grades. The signal maintainer's cars are all light cars which probably accounts in large measure for the very low cost of fuel for these cars which is shown in the above table. To secure a fair comparison of performance between cars the costs of operation should be figured on a ton mileage basis, but most roads have not attempted such an accurate study of the performance of their cars. On one road, which is conducting extensive experiments on gasolene propelled cars, it has been found that a section car carrying six to eight men can operate for about \$0.50 to \$0.60 per 100 miles for gasolene alone, which is equivalent to \$0.65 to \$0.75 per hundred ton miles.

In this connection the following statement showing the results of the operation of six gasolene motor cars purchased for test purposes on the St. Louis & San Francisco is of interest.

Make.	Location.	Put in operation.	No. days in service.	Days out of service.	Miles operated.	Average No. men (daily).	Cost of Gasolene.	Cost of Cylinder Oil.	Cost of Spark Plugs.	Cost of Batteries.	Misc. repairs.	Total cost to operate.	Cost per 100 miles.	Miles per gal. of gasolene.	Increased efficiency in time saved.
Standard Hand with Fairmont Engine No. 820. Cost \$104.00.	Lockwood, Mo. Northern Div.	7-6-12	144	0	1,877	5	48 \$5.92	3¼ \$0.75	1 \$1.25	6 \$0.81	0	\$9.73	\$0.52	39.1	721 hrs. \$90.12
Fairbanks-Morse Car No. 32. Wt. 890 lbs. Cost \$235.00.	Lockwood, Mo. Northern Div.	8-5-12	124	0	1,681	4	64 9.28	3¼ .90	3 3.75	0 .00	0	13.93	0.83	26.3	655 hrs. 81.87
Buda Car No. 19. Wt. 900 lbs. Cost \$300.00.	S. Greenfield. Northern Div.	8-10-12	119	0	1,190	4	49 7.10	4¼ 1.02	2 2.50	6 .84	0	11.46	0.96	24.3	423 hrs. 41.41
Rockford No. 4. Wt. 900 lbs. Cost \$225.00.	Everton, Mo. Northern Div.	8-4-12	93	10	918	5	47 6.81	4½ 1.21	0 .00	0 .00	7.50	15.52	1.69	19.3	262 hrs. 31.44
Fairbanks-Morse Car No. 33. Cost \$333.00.	Iron Bridge Gang.	7-27-12	124	0	3,607	15	366 53.07	26 6.24	2 2.50	8 1.11	0	62.92	1.74	9.9	716 hrs. 286.08
Buda Car No. 32. Wt. 875 lbs. Cost \$225.00.	Fort Scott. Northern Div.	1-28-12	88	1	694	7	38 5.52	3 .81	2 2.50	6 .81	1.00	10.44	1.50	18.0	413 hrs. 51.62

NOTE.—Heading "Increased Efficiency in Time Saved" has reference to number of hours saved during week with motor car compared with old style hand car. All of the above cars shown on this test sheet have been operated with the cheap grade of oil or distillate.

crease in their territory, the use of motor cars allows the maintainers to answer trouble calls more promptly, which means an important operating economy on a busy line.

Inspection cars for track supervisors, roadmasters and bridge and signal supervisors have evident advantages. By the use of a car more frequent inspections can be made, keeping the officers in closer touch with the work and creating a better spirit among the men. On some roads a section car has been used to make periodic superintendent's inspections with very good results, although for this purpose some of the larger cars are more comfortable and can be run at higher speeds.

The cost of operating motor cars varies between wide limits on different roads and under different conditions on the same road and the work performed by cars reported in the same

For comparative purposes, the above data must be considered in connection with the service performed. For instance the cost of operating the Fairbanks-Morse car No. 33, carrying 15 men, cannot be fairly compared with that of the Fairbanks-Morse car No. 32, carrying four men. Also the savings in hours and dollars depend largely upon local conditions, including length of sections and mileage run by cars.

The most important question to be considered by a road before the adoption of motor cars is the type which is best suited to the conditions to be met. The growing demand for cars has led to the design of numerous small engines which are adapted to installation on old hand cars. A number of roads have tried this expedient and general satisfaction is reported. One of the principal arguments in favor of the converted hand car is its

low cost. In many cases the foremen themselves have realized the advantage of a motor driven car and have bought small engines themselves when the roads failed to provide them. The advocates of motor cars proper point out, however, that if the full value of the hand car is added to that of the applied engine, the cost is not so far below that of a motor car of equal power. The hand car has the advantage over most motor cars that it is lighter, making it easily removable from the track, an item of considerable importance when section forces are reduced during the winter. On the other hand motor cars are more rigidly constructed and the frame is probably better adapted to stand the service which such a car receives. In the latest design of engines for application to hand cars, one of the early disadvantages that such engines could not be reversed, is being eliminated.

There has been considerable discussion as to the relative merits of two cycle and four cycle engines for cars in maintenance service. The two cycle engine has a number of advantages, being simpler to operate, as the careful valve setting on a four cycle engine is eliminated. It is also possible with a two cycle engine to mix the lubricating oil directly with the gasoline, which eliminates the possibility of trouble from a failure to fill the oil cups. Some gasoline engine men question, however, the advisability of thus mixing the oil on account of the tendency of this practice to increase the carbonization in the cylinders. The principal advantage of the four cycle engine is that it is more efficient, that is, it produces more power from the same amount of fuel.

For the sake of simplicity, motor cars are frequently built with a single speed. Considering the class of men who have to operate them, this is probably advisable in most cases. One road in this report mentions the fact, however, that a variable speed engine is more suitable for inspection, allowing the inspector to examine the track carefully at points where such inspection is needed and to run faster when he is not inspecting, thereby effecting a considerable saving in time.

The manufacturers of motor cars are continually improving their products, and a number of general tendencies in design are noticeable. More steel frame cars are being placed on the market than ever before, a recent development of this type being the welded frame which eliminates all rivets. The wheels used on the cars are not as large as in earlier designs, the usual size specified in the new cars being 16 to 17 in. On account of the unreliability of motor cars in previous years, many buyers insisted that crank handles be provided on the car so that in case of an engine failure the men could pump the car. With the increasing reliability of the motors, this necessity has practically passed and very few of the new cars are being equipped with handle bars.

Motor cars for maintenance gangs and inspectors are not intended for high speeds. While some of the earlier cars were geared to allow a maximum speed of 35 miles an hour or more, this is no longer done and most maintenance men advocate a speed limit of not more than 20 miles an hour. As a large proportion of the accidents are caused by cars being run at too high speeds, it would seem advisable to place some such definite limit on the speed.

The very large number of motor cars which is being used creates a difficult problem in securing gasoline for the operation of the cars at a reasonable price. Principally because of the rapid increase in the number of automobiles the cost of this fuel has advanced very rapidly, and from all indications as to the probable future production and consumption, this price will advance still more in the next few years. Some very important experiments are being carried out by several roads in an attempt to find a cheaper fuel for the operation of all gasoline engines in use. Crude oil has been used with good results in some places for stationary engines, but the difficulties in adapting motor car engines for this fuel have so far prevented its adoption in this field. A product known as "motor spirits," which is considerably cheaper than gasoline, and can be used

without any change in the engine, is also being tried out at present. On account of the importance of this matter, however, further tests will be necessary and some substitute for gasoline or a modification of its use will probably be found to make these cars as economical in the future as they have proved in the past.

## THE STANDARD TRACK SCALE OF THE P. & L. E.

About 1900 the Pittsburgh & Lake Erie rebuilt all of its track scales, using steel frames, concrete foundations and the best 120-ton track scales available. For a short time these new scales gave fairly good results, but in many cases they were not all that could be desired. In 1906 and 1907 more or less serious trouble arose from these scales, largely owing to the large number of high capacity steel cars coming into common use.

An inspection of these scales developed the fact that the design and construction of scales was not keeping pace with the very rapid increase in the weights of cars. Two kinds of defects were evident. In the first place they were those due to the wear of the knife edges which caused a more or less uniform error



Fig. 1—Pedestals in Place in New P. & L. E. Scale.

in the weight shown by the scale, and which could be eliminated at the regular monthly test of the scales. The second class was more serious, and was due to the scales being too light for the car loads, resulting in a displacement of the knife edges, which was liable to change the multiplication and produce errors of considerable magnitude. The deflection of the track beams on the scale also caused a displacement of the knife edges which resulted in errors of considerable magnitude.

Because of the seriousness of the situation it was decided that a new scale should be designed in which these errors would be eliminated. This company communicated with the Fairbanks Co. and made a number of suggestions based on this experience which were incorporated in the design of a new scale. These suggestions were, first: the use of a frame for the support of the track on the scale of sufficient strength to properly carry the car loads without serious deflection between the knife edges. Sec-



ond: adequate construction of the scale parts so that they would possess sufficient strength to properly carry the loads without overstressing. Third: the proper anchoring of the scale to prevent its motion unnecessarily on the knife edges. Fourth: the



Fig. 2—Arrangement of Levers of New P. & L. E. Scale in Pittsburgh.

use of a rail or bridge at the ends of the scale to transmit the loads onto the scale gradually.

In accordance with these conditions the scale now used on the



Fig. 3—Construction View of New P. & L. E. Scale.

Pittsburgh & Lake Erie was built. Main lever stands are placed directly on concrete foundations and all pocketing of piers is eliminated. The dead rails are supported on girders entirely independent of the weighing mechanism. The main girders are 24 in., 80-lb. I beams rigidly secured to the masonry walls of the pit by transverse bracing. The main levers are of cast iron with load and fulcrum pivots 12 in. long and with tip pivots 4.5 in. long. All pivots in the end and middle extension levers are heavily reinforced to insure against breakage.

The weighing beam is graduated by 20 lbs. up to 2,000 lbs., and is carefully notched, fitted and sealed. It is equipped with a 50-lb. poise. The multiplication of the levers is as follows: main levers, multiple 4; extension levers, multiple  $8\frac{1}{2}$ ; fifth lever, multiple 6; shelf lever, multiple 2. This gives a multiplication of  $33\frac{1}{3}$  at the tip of the middle extension levers; a multiplication of 200 at the tip of the fifth lever and of 400 at the butt of the weighing beam. The extension lever stands are furnished with loose rocker steels to maintain full line contact with the pivot edge at all times. The anchoring of the scale against unnecessary motion longitudinally on the knife edges is arranged by means of substantial rigid connections to the main girders,



Fig. 4—Top of New Scale Ready for Application of the Deck.

while the transverse movement is prevented by steel castings securely attached to the foundation walls and to the main girders. Pin connections are provided between these castings and a center turnbuckle connection for adjustment. The pivots and bearings are of cast steel ground true to line, hardened and polished.

To enable the load to be delivered to the scale gradually, a "bridge rail" with one end resting on the embankment and the other on the scales at a point in advance of the knife edges, was designed. These bridge rails are between 7 and 8 ft. long, and a wheel moving over this rail at a speed of 4 miles per hour requires a little more than one second to pass from one end to the other, indicating the rate of application of the load. This bridge rail is further provided with easer rails at each end to remove any possibility of "hammering." This arrangement has removed the very serious trouble formerly resulting from the sudden application of the loads, and has also allowed the use of the Streeter-Amet automatic weighing and recording device with good results.

Another feature of the scale is the large pit which is entered by a stairway from the scale office. The deck is constructed of steel plates resting on the masonry on the walls of the pit rather than on the scale itself, eliminating any inaccuracies in weight due to debris on the deck. The openings through which the live rail stands project are covered with metal shields to prevent moisture and dirt from entering the pit.

Another device installed with these scales prevents the weight

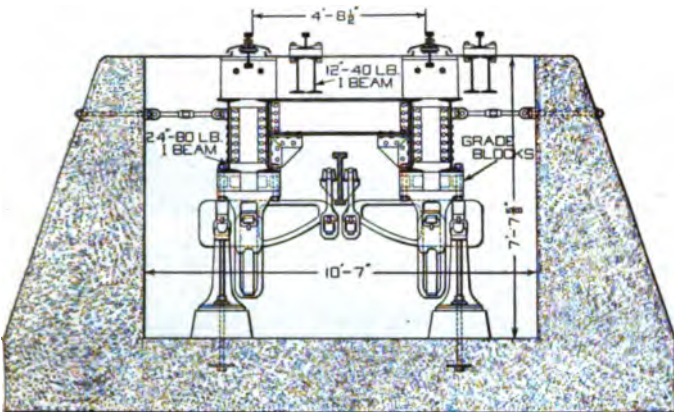

Fig. 5—Cross-Section of New P. & L. E. Scale.

of one car being recorded as long as any other car conflicts with it. If a second car follows too closely the one which is being weighed, this device will prevent any weight being recorded. In this way the trainmen are required to properly space the cars, and as the Streeter-Amet automatic weighing device stamps the scale card, any attempt of the weighmaster to estimate the weight of the car is at once detected.

The first scale of this type was installed at Glassport in May, 1908, and in the five years it has been in service, over 1,000,000 cars have been weighed. At no time has the scale been found more than 40 lbs. out at the regular monthly scale inspection, and

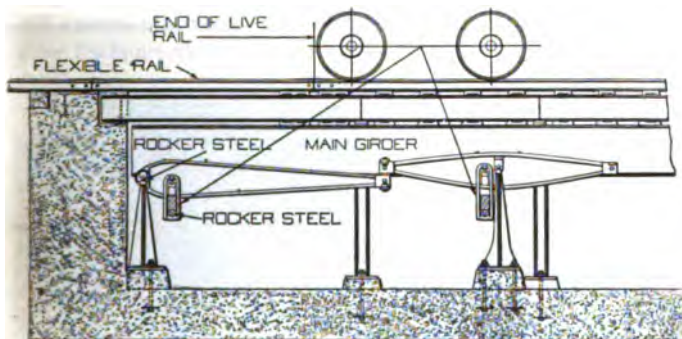

Fig. 6—Distribution of Loads Between Sections by Flexible Rail.

an examination of the knife edges made recently showed that they were in as good condition as when originally installed. The total cost of maintenance of this scale up to the present time has not exceeded \$20. Six of these scales have been installed on the Pittsburgh & Lake Erie at a cost of between \$7,000 and \$8,000 each. The accompanying photographs show the details of installation of one of these scales at Pittsburgh.

The studies of this question on the part of the Pittsburgh & Lake Erie have been made by A. R. Raymer, assistant chief engineer, to whom we are indebted for the above information. This scale was designed by the Fairbanks Company, Pittsburgh, Pa.

**MILEAGE OF INDIAN RAILWAYS.**—Including 658 miles opened in 1912, the total mileage of the Indian railways amounts to 33,484, of which a little less than half is on the standard 5 ft. 6 in. gage.

## ABSTRACT OF ENGINEERING ARTICLES SINCE JUNE 20, 1913.

The following articles of special interest to engineers and maintenance of way men, and to which readers of this section may wish to refer, have appeared in the regular weekly issues of the *Railway Age Gazette* since June 20, 1913:

**The Illinois Central Mechanical Terminal.**—The Illinois Central has recently completed a large yard with roundhouse, shops and car repair facilities at Centralia, Ill. The construction of the tracks and buildings was described in detail in an illustrated article in the issue of June 27, page 1597.

**New Southern Pacific Passenger Station at Los Angeles.**—The Southern Pacific is now completing plans for a new passenger station to be built at Fifth street and Central avenue, Los Angeles. The general features of this station were described and illustrated in the issue of June 27, page 1607.

**New Montclair Station of the Delaware, Lackawanna & Western.**—The Lackawanna has just completed new freight and passenger terminals at Montclair, N. J., involving the expenditure of \$500,000, of which the most important unit is the new passenger station. This station was described in an illustrated article in the issue of July 4, page 9.

**Specifications for Splice Bars.**—The American Society for Testing Materials adopted specifications for medium carbon, high carbon and extra high carbon steel splice bars at the annual convention held in Atlantic City the week of June 24. These specifications were printed in the issue of July 4, page 16.

**The Railroad Valuation Committee.**—The personnel of the committee of railway presidents and of the committee of railway engineers, organized to outline methods for carrying on the work of valuation of railway properties, was given in the issue of July 4, page 18.

**The St. Paul Improvements at Milwaukee.**—The Chicago, Milwaukee & St. Paul has recently made extensive additions to its yard facilities at Milwaukee. These facilities were described and illustrated in the issue of July 4, page 19.

**Assignment of Equipment Valuation by States.**—Three methods for the assignment of equipment used in interstate traffic to the various states for the purposes of valuation, were discussed by A. I. Thompson, engineer, Corporation Commission of Oklahoma, in the issue of July 4, page 21.

**Newark Bay Trestles Rebuilt in Twelve Days.**—Two-thirds of a mile of double track trestles belonging to the Lehigh Valley and a similar amount belonging to the Pennsylvania, crossing Newark Bay, N. J., were destroyed by fire on June 15. Some interesting details of the reconstruction of these trestles in the short period of 12 days were given in the issue of July 4, page 24.

**Reconstruction of the Kaw River Bridge.**—The interesting methods by which three 180 ft. through truss spans were moved transversely and endwise with little interference to traffic, were described by C. E. Smith, bridge engineer of the Missouri Pacific, in an illustrated article in the issue of July 11, page 45.

**The Minimum Efficient Gradient.**—The minimum limit to which grades may be economically reduced was discussed by Paul M. La Bach in the issue of July 11, page 55.

## RECLAIMING TIMBER WITH A RESAWING MACHINE.

The Lake Shore & Michigan Southern has in operation in its timber yard at Collinwood, O., a resawing machine consisting of an ordinary saw mill equipped with a circular saw and carriage driven by a gasolene engine. At this mill old piling and pile butts too short for bridge work are sawed into cross ties, switch ties and crossing plank, while old bridge stringers, caps and ties are cut up into sway bracing material, planking and miscellaneous lumber. This mill is kept busy most of the time reclaiming timber that otherwise could not be used. The value of the lumber reclaimed to the railway company after sawing varies from \$15 to \$25 per M board ft. The use of this material has been found to make a heavy reduction in the requisitions for new timber.

**RAILWAY SURVEYS IN HONDURAS.**—Preliminary surveys have now been completed upon the Trujillo to Juticalpa Railway in Honduras. The route of the new line will pass across the Aguan river, follow the valley of the Bonito river in the direction of Iruana, and continue from that place upstream to the Sico valley. Work will be commenced very shortly upon the first section, namely, that from the Trujillo river to Aguan, a distance of about 26 miles. French and local capital have been employed in the undertaking.

# BALTIMORE & OHIO FLOOD RECONSTRUCTION.

Description of the General Conditions Existing During the Re-opening of the Lines with Detailed Data as to Specific Points.

The disastrous floods in Ohio, Indiana and neighboring states during March and April, and the enormous damage to railway property resulting therefrom, are familiar to all. Railway men, however, are more interested in the emergency measures adopted to get the tracks back in service than in a narration of the actual damages. For the past three months all efforts have been concentrated toward the reopening and rebuilding of the lines within the flooded area, and it is only recently that information has been available showing the full extent of the damage, the method of handling the repair work and the actual cost.

Between the mornings of March 23 and March 27 precipitation continued almost uninterruptedly over the entire Ohio river basin, resulting in a maximum rainfall at this period of 11.16 in. at Bellefontaine, Ohio, and of 10.6 in. at Marion, Ohio. The rapidly rising rivers flooded their valleys, and railway operations in this vicinity were generally suspended on March 25 and 26. Among the roads in the flooded area, the Baltimore & Ohio-Cincinnati, Hamilton & Dayton system was one of the chief sufferers, having over 400 miles of track either destroyed completely or put out of commission. The losses on this system were variously estimated between \$2,500,000 and \$3,000,000, of which



Results of the Flood at Zanesville, Ohio.

\$1,625,787 is directly chargeable to actual property damage and the balance to losses in traffic.

## GENERAL ORGANIZATION.

As soon as the seriousness of the catastrophe was realized, plans were immediately made to repair the damage as promptly as possible. When it became evident that telegraphic communication would be lost, the relief work on the Baltimore & Ohio proper was placed in the hands of the general manager at Baltimore and that on the Baltimore & Ohio Southwestern and Cincinnati, Hamilton & Dayton in the hands of the general manager at Cincinnati. All general superintendents and superintendents were instructed to remain at headquarters in general charge of the work on their territories while staff officials were sent to the field in charge of repair gangs and relief trains. In the meantime preparations were made to rush men and materials into the flooded area.

The work of reconstruction was at once divided into districts, each under the direct charge of a special engineer, as follows:

Paul Didier, principal assistant engineer, Pittsburgh: Zanesville bridge.

A. M. Kinsman, engineer of construction, Cincinnati: Indiana division, B. & O. S. W. west from Cincinnati.

J. T. Wilson, district engineer, Baltimore: B. & O. S. W. east from St. Louis.

L. G. Curtis, district engineer, Chicago: Indianapolis division, C. H. & D., including Hamilton yards and bridge.

J. B. Carothers, special engineer, Baltimore: Columbus district. F. E. Lamphere, assistant engineer, Chicago; Louisville district. B. R. Hundley, resident engineer, Chillicothe: Chillicothe district and yards.

Claude Brown, assistant engineer, Chicago: Toledo division, C. H. & D., and Dayton district.

W. S. Bouton, engineer of bridges, Baltimore: Bridges.

M. A. Long, assistant to chief engineer, Baltimore: Buildings.

By the time the flood had reached its crest, 7,500 men were moving from the east toward the Ohio river. A somewhat smaller force was gathered west of the flooded area. Closely



Three Spans Gone at Zanesville.

behind them were large quantities of track and bridge material as well as construction equipment, including 20 pile drivers, steam shovels, derricks and other equipment.

In the work of reconstruction the labor problem was a most serious one and to add to the difficulty it rained almost continuously for several weeks, working a hardship among the laborers who came out poorly clothed. Many of these men came from some distance without money, and it became necessary to provide them with store order blanks that they might secure the necessary clothing. At some points the men were supplied with



The Wreckage of One of the Spans at Zanesville.

slicker suits and dry underwear, socks and boots to keep them at work during the rain. The men were fed free of charge until the lines were opened for traffic. At first the laborers were fed by dining car outfits. At one point two dining cars and two baggage cars were utilized for ten days for feeding 400 men in three shifts, each meal requiring only 1½ hours. To avoid feeding men who did not belong to these forces it was necessary to have meal tickets printed and distributed to the men by the timekeepers in advance of each meal. Later, commissary departments were established all along the line.

Unskilled labor was plentiful because the flood had stopped work on the farms and had closed local factories and other industries. Several thousand men were also shipped in from the larger cities. Skilled labor, especially carpenters, was rather scarce and many men who applied for work were inefficient. There was also much difficulty in securing efficient foremen to manage the gangs, although towards the end of the work they

The vast amount of trestle material required made necessary the adoption of extreme measures in some cases to secure it with the minimum delay. In several instances large numbers of piles 60 and 70 ft. long were required, and it was necessary to secure these on special orders. In one instance a trainmaster was sent into Missouri to supervise the loading and shipping of an order of long piles, remaining on the ground until all the



At Work on the Reconstruction of the Zanesville Bridge.

were more numerous and the problem then was to get rid of them along with the surplus unskilled labor.

Some difficulty was experienced in securing the necessary machinery and equipment to handle the vast amount of work, although pile drivers, steam shovels and derricks were secured from a number of roads and contractors not affected by the floods. While of great assistance, this foreign equipment in itself introduced complications in several instances. As an illustration, one pile driver was borrowed from the Soo which had a height of 17 ft. 3 in. above rail. It required careful inquiry to find a route over which it could be sent, and after detouring from

piles were loaded and accompanying them over detour lines until they reached their destination. The sending of a man with all detour shipments of material was generally practiced and greatly facilitated deliveries. In another instance 650 white cedar piling 45 ft. to 65 ft. long were secured at Minneapolis through the purchasing agent of the Soo, who purchased them on instructions from the Baltimore & Ohio according to Soo Line specifications.

While it is impossible in the limited space to go into detail into many interesting methods adopted to get the lines back in service, a description of the methods followed in two or three



The Crossing Completed at Zanesville After One Week's Work.

Chicago by way of Springfield, Ill., it was necessary to lower the track about a foot at West Hamilton in order that the driver would clear the structure. An added difficulty arose at several points because locomotives necessary for handling materials were marooned and unable to reach the points desired. This required additional teaming and hand labor to get material to the point of use. The difficulty in securing teams was relieved somewhat by the fact that many of the towns were under martial law and idle teams were put to work by the state without pay. The influence of martial law was also felt among the laborers, for after a few leaders in small strikes were turned over to the militia officers and put at work without pay, the others were more ready to work for the railways.

of the larger problems may be taken as typical of those over the entire area.

#### ZANESVILLE BRIDGE RECONSTRUCTION.

The most serious damage occasioned by the loss of a bridge was at Zanesville, Ohio, on March 26, when three out of four 128 ft. 6 in. through truss spans across the Muskingum river, were carried out, one span at the west end of the bridge remaining. The water also extended over the main track for a distance of three miles east of the Zanesville station, flowing at the rate of 10 or 12 miles an hour. Gangs of 80 laborers and 78 carpenters were sent from Baltimore by special trains and started making repairs to the track on March 29. A self propelling derrick car

belonging to the Seaboard Construction Company, with a crew, was sent from Philadelphia, arriving at Zanesville on April 1, while another car belonging to the Lucius Engineering Company was sent from Garrett, Pa., arriving on April 3.

About April 3 all the material necessary for the temporary structure was on the ground ready for use as soon as the water receded sufficiently. Pending the fall of the water the time was utilized in framing timber bents, consisting of two 12 in. x 12 in. double batter posts bolted together with 14 in. x 14 in. caps securely drifted to the batter posts and secured by sash and diag-



One Example of the Flood Damage near Dayton, O.

onal bracing. The height of the bents could only be approximately determined, as several attempts to take soundings with three 100 lb. rails securely bolted together failed because of the swiftness of the current.

Pending the arrival of the derrick cars the men were engaged in removing debris, including box cars and all kinds of flood material from the tracks as fast as the water receded. After clearing the main track up to the bridge it was found that the current was still too swift to enable any falsework to be placed. It was first contemplated that the derrick car on the west end of the bridge would carry the framed bents required on that end from where they had been assembled to the bridge, but this plan was



Damaged Freight at Dayton.

abandoned, as the assembling yard was too far removed from the bridge. It was also found expedient to remove the top struts, top laterals and portals from the remaining span of the bridge so that the derrick car could move over it with the "A" frame up. Although the derrick car was self propelled it was moved back and forth with a shifting engine to expedite the work.

On April 6 the water had fallen sufficiently to enable the placing of the river bents to be started. As these bents had been

framed in approximately uniform lengths, they were picked up by the derrick car, weighted, lowered to their proper place and then fitted to the ground. Whatever unevenness was found on the bottom of the river, which is a shale rock, was measured and cut off of the bottom of the batter posts so that on the second or third trial the cap was horizontal and at the proper height to receive stringers. Because of the various lengths of stringers received, it was decided that a maximum spacing of bents of 14.5 ft. center to center was advisable. To insure the bents being placed at these centers a scow was constructed with the proper



Destruction of a Bridge at Miami City, near Dayton.

width of outriggers. After the first bent was securely placed this scow was attached to it and to the shore, and the bottom of the next bent placed by means of the scow. The top of the bents was easily taken care of with horizontal laterals.

The first bent was placed in the river on Sunday morning, April 6, and the last bent on Friday morning, April 11, 26 bents having been placed in this time. Because of the dangerous character of the work it was decided to eliminate all night work. Following the completion of the trestle the temporary construction deck was replaced with new ties, rails and guard rails, and additional stringers were added. The structure was turned over to traffic on Monday forenoon, April 14.

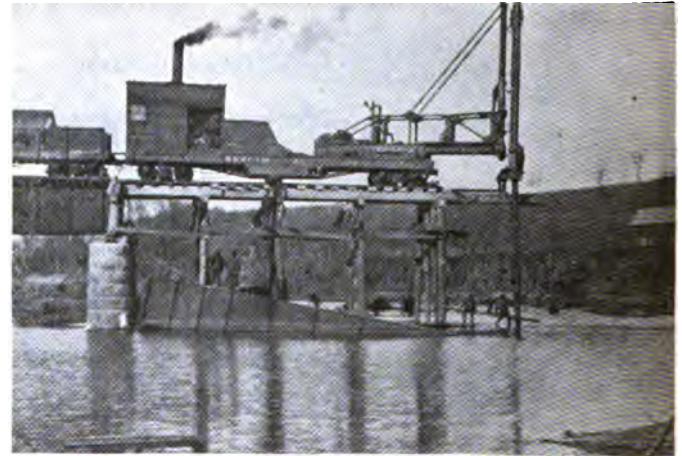

Replacing a Girder Span with Piles at Brownsville.

Approximately 14,000 ft. b. m. of lumber and about five tons of bolts and spikes were used in the construction of this temporary bridge, most of the bolts being made on the ground because of the uneven lengths required.

#### REPAIR WORK AT CHILlicothe, OHIO.

Another serious situation existed at Chillicothe, O., where about five miles of track through the city was lost. Here a detour line 4,800 ft. long was built over an old canal towpath as

a quicker means of opening a portion of the line badly washed out. Although the water reached its highest stage on March 26, it was impossible to secure either men or teams until March 29, when eight teams were started grading for this detour track. A trestle about 190 ft. long and 12 ft. high across a ravine was built by a gang of about 30 men, working continuously from Saturday until they completed it early Monday morning. The entire detour of about 4,800 ft. was completed and put in service on Monday, March 31. In laying track on this line it was necessary to take up the rail from a passing track at a station six miles west to secure the necessary material. In the meantime the track from the station west to the east end of the detour line has been rebuilt by a force composed largely of machinists, boiler-makers, yard switchmen, engineers and firemen.

Considerable difficulty was experienced in getting a track through the Chillicothe yards, as at the time of the floods all the yard tracks were filled with cars, 75 per cent. of which were loaded. In the vicinity of the coal tippie the tracks were on a fill about 8 ft. high. This fill was completely destroyed and many of the loaded cars were overturned on the main line. On this account it was necessary to build a few feet of track and then run a crane in on this track to remove the overturned cars before further advance could be made. No cribbing was used to build up tracks in the vicinity of Chillicothe except where absolutely necessary to prevent delay to track laying, as the ground



One Track In the Stream at Kent, Ohio.

in this vicinity carries a large amount of moisture, making the life of timber unusually short and increasing the difficulty of future maintenance.

At the west end of the bridge over the Scioto river the embankment was badly washed out for a distance of 5,400 ft., the track being turned over two or three times and left an average distance of 200 ft. from its original location. The grading for this distance was done by hand and the track replaced on it by means of heavy block and tackle. On the next mile the track was left an average distance of 275 ft. from the center line, and it was necessary to cut it into sections and drag it back by teams.

On Wednesday, April 2, the river again rose 12 ft., and at two points east of the Chillicothe yards where the track had been rebuilt slightly above the original surface of the ground, it became necessary to reinforce the light embankment. Three carloads of cement which had passed through the flood and were therefore useless except for rip rap, were used to protect the bank at this point, finally saving it.

Several thousand yards of good gravel were deposited by the flood on the south side of the tracks about a half mile east of the passenger station. This material was loaded with a ditching machine and used to excellent advantage for ballast.

On this work efforts were made to haul the men to and from work and to meals with work engines to reduce the amount of time spent in unnecessary walking back and forth. To prevent confusion on the work a bulletin outlining the work to be done

the following day was issued daily in the form of a letter to the general foreman, copies being sent to the superintendent, chief dispatcher, trainmaster, master mechanic, and all heads of departments. In this way there was no confusion of orders, each man in responsible charge of any department thoroughly understood what was to be done and there was ample time for suggestions regarding improvements in methods to be acted upon if they were consistent.

At the bridge over the Scioto river there was about 800 ft. of pile trestle, the entire deck of which was removed by the flood and deposited about 100 ft. from the bridge. This deck was recovered in sections by means of blocks rigged on gin poles and with minor repairs was replaced on the trestle.

#### OTHER TYPICAL WORK.

At one point on the Illinois division about three miles of track and one mile of siding were moved from 5 to 20 ft. from their location. In one instance 2,000 ft. of track was moved from the roadbed and left upside down against the telegraph poles in 4 to 6 ft. of water. This track was brought back to the foot of the embankment by block and tackle hitched to "dead men" and trees. It was then necessary to tear the track apart, carry it up the roadbed and relay it.

In this same vicinity it was necessary to drive piles for the crossing of the White river to replace two 210 ft. spans. At this point there was from 30 to 44 ft. of water with a very swift current, making it difficult to start the piles and endangering the pulling of the pile driver in the stream. To overcome this, a  $\frac{3}{4}$  in. steel cable was anchored up-stream and in connection with a block and fall, was used to steady the piles until they were picked up by the hammer.

In driving a temporary structure 1,511 ft. long over the Great Miami river at Hamilton, O., a floating raft was used for spotting piles for driving. This raft was made of 8 x 16 in. stringers with a flash board on the up-stream side to float it in the swift current. It was built in three sections. By means of 6 in. x 8 in. timbers spiked across the top of the swinging raft and extending over the edge, it was possible to spot a pile in the proper position without the necessity of holding it. This raft was readily moved ahead as the work progressed and materially reduced the time required.

At the crossing of the White river about 17 miles east of Seymour, Ind., a considerable amount of track had been washed off the embankment. To get this back in place it was cut into sections of two rail lengths and pulled back onto the embankment with a light locomotive and cables, blocks and "dead men." It was possible to pull up about 1,500 ft. of track per day in this way. In the vicinity of Troy, O., 2,000 ft. of track was turned over. This was turned back without unbolting the rail by raising short sections as nearly vertical as possible with jacks and then using rails for levers back of the point where the ties stood upright.

It is interesting to note that in the midst of this work means were also provided to assist the public in various ways in addition to giving shipments of food and supplies right of way over all other traffic. At Hamilton a bridge was built over the Miami river by the railroad for the county at cost. This structure provides a roadway for teams, street cars and interurban traffic and a 6 ft. walk for foot passengers. It is 500 ft. long and was completed in about ten days. At another place in the same city where there was no means of crossing the river except by boat, a 4 ft. walk was built on the down-stream side of the railroad bridge in connection with its reconstruction.

**NEW RAILWAY IN THE ENGADINE, SWITZERLAND.**—The Lower Engadine Electric Railway, connecting St. Moritz with Schuls and Tarasp, was inaugurated on June 28. The line is to be continued towards the Tyrol, and will eventually constitute a main line from Chiavenna, Italy, across the Engadine to Landeck, Austria.

## FLOOD RECONSTRUCTION ON THE MONON.

By E. G. STRADLING,

Signal Engineer, Chicago, Indianapolis & Louisville, Lafayette, Ind.

The northern and central parts of Indiana are generally level with the river channels going through the broad lowlands in many places. These lowlands are frequently in the form of a series of sweeping curves with the river on the outer edge. With every rise in the streams it is the natural tendency of the water to flow across these lowlands, the stronger current following the shorter inner border of these areas. The railways generally cross these streams with a bridge across the main channel and a long high fill across the lowlands.

In recent years extensive drainage systems have been built



Fig. 1—Monon Tracks in Broad Ripple, Ind., After the Flood Had Partially Subsided.

by the farmers in this vicinity so that today the water which in the past formed ponds several feet in depth is now quickly removed from the fields. With the exceedingly heavy rainfall of March 23 and 24, we have the conditions which caused an unprecedented rise of all streams resulting in their sweeping across the lowlands against the railway embankments which lay across their paths. So rapid was this rise that in some instances the surface of the water was found by actual measure-



Fig. 2—Wabash River Crossing near Lafayette, Ind., at the Crest of the Flood.

ment to be over 3 ft. higher on the up-stream side than on the lower side of the fill. Under these conditions if the fill was sufficiently high and strong to withstand the pressure the water was forced through the bridge opening scouring out the sup-

ports in many cases. On the other hand where the fill gave way the bridge was saved in many instances.

On the Monon there were only two instances of bridges being damaged by the floods. At Gosport a down-stream corner of one pier supporting the bridge over White river was undermined, but the scouring was stopped by the unloading of several car-



Fig. 3—Condition of Roadbed After the Flood at the Wabash River Crossing near Lafayette, Ind.—Ties Standing on End Against Telegraph Poles.

loads of spalls from a nearby quarry. At the crossing of Fall Creek north of Indianapolis, the up-stream end of the center pier was badly undermined and afterwards settled, throwing the bridge slightly out of line. At this point the bridge was returned to its proper position by jacks and will be supported by falsework until a new pier can be built.

Washouts were more numerous. To repair such damage steam shovels were immediately set at work in gravel pits. As the other roads in this vicinity were laboring under the same



Fig. 4—Embankment Across Wabash River Lowlands Restored to Its Former Elevation. Rails and Ties from the Overturned Track Piled on the Shoulder.

conditions it was with extreme difficulty that detour routes were worked out for the movement of this material and other supplies to the points where they were required for repairs.

In one instance just north of Lafayette, Ind., the road crosses the lowlands adjacent to the Wabash river on a fill nearly a mile long, the river proper being at the north end of the fill. The main strength of the flood current was directed upon the opposite end of this fill, and it was in many spots washed out practically to the original ground level. As the track started to slide over the side of the fill the water caught it and turned it completely over or left the ties standing on end against the

telegraph poles. To get this track back onto the bank it was in some instances cut into short sections and drawn back into place by men with lining bars. Another method was to place a "dead man" on the opposite side of the fill and to draw sections of the track back into place with block and tackle. As fast as the track was restored to place, ballast cars were pushed forward and unloaded. Teams with scrapers were also employed to drag gravel back to the top of the roadbed from the toe of the slope where it had been left by the flood. At this same point the telegraph line was badly damaged and a single line of rubber covered wire was laid across the gap by means of a motor boat to reopen service. At this Lafayette washout the track was put back in service in a week almost to the hour from the time when it was washed out.

### THE BURLINGTON'S CONSTRUCTION ORGANIZATION.

The Chicago, Burlington & Quincy has for many years followed the practice of doing as much as possible of its improvement work along existing lines, other than grading by teams, with company forces, and to this end has gradually acquired a large amount of construction equipment. To properly maintain and operate this equipment a separate department was organized about eight years ago under the direction of a superintendent of construction equipment with headquarters at Galesburg, Ill. This officer has charge of all construction equipment assigned to the 4,500 miles of lines east of the Missouri River except that used by the bridge department. The repairs of bridge department equipment are made by the construction department, although the operation is under the direction of the bridge engineer. In general, the duties of the superintendent of construction equipment are to maintain the equipment in proper repair and to supervise its distribution over the various divisions of the road as required, to provide crews, and in conjunction with the local division officers, to direct its economical operation.

Excluding the equipment of the bridge department, the construction equipment on the lines east of the Missouri River comprises 15 Bucyrus steam shovels including two new 70-ton and two new 85-ton shovels, seven Barnhart ditchers, 17 Jordan spreaders, 10 Rodger ballast plows, 34 center and side plows, 14 Lidgerwood unloaders, 1,230 Haskell & Barker cars, 658 Rodger ballast cars and 50 Kilbourne & Jacobs 20-yd. air dump cars. In addition, six American rail loaders, five Browning Engineering Co.'s clam shell excavators and all yard and wrecking cranes as well as 1,200 bunk cars for floating gangs are in charge of this department.

This department was created because of the difficulty in securing a proper output from the shovels and also in keeping them in repair. Largely to insure co-operation in the making of repairs, the superintendent of construction equipment is attached to the mechanical department, reporting to the superintendent of motive power, although in the direction of work he co-operates more closely with the general manager and the engineer maintenance of way. By this connection with the mechanical department, repairs to equipment can be promptly and properly made. As a general rule, however, only emergency repairs are made by the regular shop forces, the routine repairs and annual overhauling being made by the shovel crews while the shovels are laid up during the winter.

The shovel engineers and a portion of the cranemen are retained throughout the winter and are employed in the Galesburg shops in overhauling the equipment. The men work in one gang and completely overhaul each shovel. In this way the equipment is put in proper condition by the men who are to use it the following season, ensuring better work and at the same time giving these men experience of assistance to them in operating the shovels as well as giving them continuous employment. As

a result of this method the delays on the construction work because of break-downs are small and are made by the regular crews. Parts showing indications of early breakage are replaced on Sundays and as far as possible all minor repairs in the field are deferred until this time to avoid delay to the work. As a result there has been no break-down sufficient to require sending the shovel to the shop since this department has been organized.

An inspection of the boilers is made semi-annually by a company inspector and all engineers are required to pass an examination before being allowed to run a shovel. All repair parts for this equipment are kept separately by the store department and the superintendent of construction equipment co-operates with the store department in maintaining the proper stock of material. All requisitions for supplies and repair parts pass through his office for approval before being sent to the store department.

In distributing the equipment to the various divisions the superintendent of construction equipment co-operates closely with the engineer maintenance of way. A list of all work planned for the year with the quantities of material to be moved, the estimated length of time required and the time when it is desired to do the work is made up early in the year and from this a schedule showing the movement of the various items of equipment is prepared. This schedule is revised at frequent intervals as the conditions change so that all concerned know when a shovel or other equipment is expected to complete certain work and where it will go next and can plan accordingly. If a division superintendent desires a shovel for work not shown on this schedule he makes a request to the general superintendent or general manager, giving the details of the proposed work. This request is then referred to the construction department and is complied with as closely as possible.

One advantage of this system of handling equipment is that resulting from concentrating the supervision of company construction work in the one office. The superintendent of construction equipment spends the larger portion of his time on the line visiting the shovels and watching their operation. He is thus able to distribute the auxiliary equipment such as plows, cars, spreaders, etc., to the best advantage, securing the maximum service from the equipment without delaying the shovels. An outfit will frequently have a right hand, a left hand and center plow, although they may only use one for a week or more at a time. Likewise, due to a variation in the length of haul, a crew may be able to release a number of cars for a considerable interval, thus reducing delays on another job or perhaps eliminating the necessity of fitting up other cars. The difficulty of getting crews to release such equipment without some such supervision is too well known to require comment.

Another object in visiting the various pieces of work is to study the conditions under which each shovel is working in order to reduce the delays and increase the output. In addition to seeing that sufficient equipment is at hand the superintendent of construction equipment advises regarding the track layout in the pits or on the unloading dumps. He is also on the ground whenever a shovel cuts in or out in a difficult place. As an instance of the results of the studies of delays it was found this spring that several shovels working in side hill rock cuts were seriously delayed by blasting immediately in front of the shovel. Investigations showed that steam drills were unable to keep ahead of the shovels in these instances and it was found that the substitution of Cyclone well drills enabled the drilling to be kept ahead of the shovel, eliminating these delays. Another recent move has been to furnish pitmen with rubber boots and raincoats and the shovels now work regardless of weather conditions. These boots and coats are turned over to the shovel engineer, who is responsible for them the same as for the tools. All shovels are supplied with tank cars and are coaled and watered at night by the night watchman to avoid delay during the daytime. While these measures are not new on contract work, they



are not all generally found on railway work, with its less detailed supervision.

When out of service for the winter the construction equipment is assembled at Galesburg, a special yard being provided for the storage of that portion of equipment that is not diverted to other uses. All crews are assembled here before going out in the spring. The shovel engineers secure pitmen locally but firemen, cranemen and watchmen are hired by the superintendent of construction equipment. Thus, when a shovel is sent to a division the division superintendent is required to furnish only the work train crews. In assigning shovels it is aimed to give the shovel engineers the same shovels year after year, although greater consideration is given to assigning the engineers to the kinds of work for which they are most fitted. In sending out a shovel the firemen and watchmen are sent with it, while the engineer and cranemen travel by passenger train.

Each shovel engineer sends a daily A. B. C. wire report to the superintendent of construction equipment, engineer maintenance of way, general superintendent and general manager, giving the shovel number, its location, amount of material loaded and the extent and nature of delays. He also sends by mail a weekly report to the superintendent of construction equipment, giving the amount of auxiliary equipment on hand, the amount and nature of the delays during the week and the nature and extent of the repairs made to the shovel. A report is also made weekly by the superintendent of construction equipment to the engineer maintenance of way and general manager, showing the location and condition of all equipment. The time rolls of the shovel crews are made up by the various division superintendents, a copy being sent to the superintendent of construction equipment.

All shovels, plows and other equipment are numbered and a complete record is kept in the office of the superintendent of construction equipment. All correspondence and instructions regarding this equipment are based upon these numbers. The clerical records relating to movement of cars assigned to construction service are kept in the office of the car accountant, although the distribution of the cars is handled by the superintendent of construction equipment, as outlined above.

A large proportion of this construction equipment is diverted to other uses during the winter months when construction work is closed down. The aprons on the Haskell & Barker cars are replaced with end gates and these cars, as well as the Rodger ballast cars, are turned over to the operating department for coal service. Several steam shovels are regularly employed as cranes for miscellaneous yard work and for loading coal while the use of a shovel for spotting cars at an icehouse was described in the *Railway Age Gazette* of March 15, 1912, page 498.

Closely associated with the construction equipment is the distribution of bunk cars for all maintenance forces. The fitting up of these camps, including bunk, dining, refrigerator and commissary cars for various nationalities and their distribution over the different divisions, is handled by this department. Over 1,200 bunk cars are now in service on the lines east. Instead of the division superintendent having to fit up his own camp for his gangs he has only to wire the superintendent of construction equipment the number of men he proposes to put on and the nationality. The cars are then fitted up completely or transferred from another division and sent to the division ready for service.

This work is under the supervision of O. W. Duffy, superintendent of construction equipment, to whom we are indebted for the above information.

**RAILWAY ACCIDENT IN INDIA.**—A railway disaster is reported from Ondal, in Bengal, on a branch of the East Indian Railway. A bridge over a river between the stations of Panchra and Dubrajpur was partly washed away on July 4 by a heavy flood. A passenger train which left Ondal at 4:30 a. m. on July 5 ran on to the bridge. The engine and eight passenger cars were precipitated into the river. The other cars were saved by the breaking of a coupling. Fourteen bodies have been recovered.

## INGOT IRON.

An article was published in the *Railway Age Gazette* for September 30, 1910, on the development of the manufacture and the peculiarities of ingot iron as made by the American Rolling Mill Company, of Middletown, Ohio. Ingot iron was then shown to be an almost pure iron and, as such, possessed of high rust resisting qualities. When compared with the Swedish charcoal or English wrought iron, its ultimate strength was about the same, while its limit of elasticity was considerably greater. At that time it was made in small ingots weighing from 800 to 1,000 lbs., and the total output amounted to about 25,000 tons a year, a very large percentage of which was rolled into sheet metal of gages ranging from 12 to 20, and, after having been galvanized was worked up into corrugated culvert pipe. The iron is nearly pure, and as such, its rust resisting qualities made it especially valuable for this purpose. The metal was also used for electrical work, where sheets of great purity were required.

Since that time the company has built a new mill at Middletown and added to its facilities so that the present output of ingot iron is about 50,000 tons a year, or an increase of about 100 per cent. in three years. The metal itself, so far as its chemical composition and physical properties are concerned, is about the same as before, but constant investigation and research have developed a number of modifications in methods of manufacture that have put the output on a far more extended commercial basis. In 1910 the ingots employed in the manufacture of this material weighed approximately 1,000 lbs. Since the completion of the new mill, which embodies the latest and best principles of modern rolling mill construction, larger ingots, approximately 6,500 lbs. in weight, are now produced. These ingots remain liquid for a much longer time than the smaller ones, so that there is better opportunity for included gases to escape than there was under the old methods. In addition, the larger ingots necessarily receive about four times the amount of working in the rolling which obviously produces a denser and more uniform product.

In 1910 nearly the whole output was rolled into thin sheets and used for culverts or electrical work, and no heavy plates were rolled. In addition to its exceedingly wide application in the manufacture of corrugated culverts, it is now rolled into plates up to ½ in. in thickness, and these are extensively used for stand pipes for water, gas-holders and oil tanks. A prominent oil refining company finds that its life in the bottom of stills is from two to three times that of steel. It is especially valuable for gas-holds where the metal is alternately wet and dry; as with galvanizing, it holds the paint better than steel and does not need repainting as frequently. It is extensively used for vats and kettles in breweries. A prominent railroad is having 600 refrigerator cars built, whose roofs are to be of ingot iron, and a large car company is building 67 tank cars from the same material, to carry acid. The smelting companies find that the hoods over their furnaces last two and three times as long when made of ingot iron as when steel is used. On a 6,000 ft. pipe line in Colorado, that runs through an alkali soil, ingot iron is being used by the government. This includes, not only the pipe itself, but all flanges and rivets. Recently it has been rolled into wire rods and drawn into wire, and is extensively used for wire fencing. It is curious that this turns out to be one of its later applications, although it was Dr. Allerton Cushman's investigation into the rapid corrosion of fence wire that was the immediate inspiration of the investigations that led to the development of ingot iron. It is also found to be an excellent basic metal for the manufacture of crucible steel and experimental applications also show it to be especially suited to the making of boiler tubes. It is thus occupying a continually broadening field of industrial application and promises to become one of the most extensively used of the staple iron products.

It was learned very early in the development of the process

that the presence of oxygen in the iron had a very injurious effect. It rendered the metal brittle and difficult to roll and produced blisters on the galvanized sheets. For that reason it has been the custom, at Middletown, to analyze for oxygen in every heat and the present practice is to put an upper limit on the content at .05 per cent., though this is seldom touched, as the furnace practice holds it at from .02 to .03 per cent. It is understood that the furnace practice involves the burning out of the impurities by a protracted high temperature, so that the time required for melting and refining a charge of 60 tons in an open hearth furnace runs from 12 to 14 hours, as compared with from 9 to 11 hours when the mild steels are made. The long duration of the refining period and the extremely high temperature required to reduce impurities to but little more than mere traces results in a considerable oxidation of the iron itself, which oxidation makes necessary a subsequent corrective treatment. The final result is that the oxygen is reduced to a point as low as it is possible to bring it by means of the best known deoxidizers.

As for the nitrides existing in the metal, for it is assumed that most of the contained nitrogen exists there in the form of nitrides, considerable has been done towards their elimination, and they are the object of attack and investigation by the research department of the works. The practical methods employed to purify the metal are to stir the bath vigorously at frequent intervals, so as to stimulate the liberation of the gases, and to allow the bath to stand after it has melted until the gases are well out of it. Not only do the large ingots remain molten for a much longer time than the small ones previously used, but ingot metal remains fluid much longer than steel, and even when there is a substantial shell of solid metal formed about the outside of the ingot, there will be a central core that is very fluid through which the gases are free to rise. Ingot iron does not seem to pass through the prolonged plastic condition so characteristic of steel but remains soft until it suddenly freezes; so that it is frequently from 20 to 30 minutes after an ingot is poured before it solidifies at the top. This probably explains, in part, why it has less nitrogen, even, than crucible steel. This nitrogen content is now being very carefully watched, while every heat is analyzed for oxygen. The method includes the splitting of ingots, the analysis for oxygen, hydrogen and nitrogen and an examination under the microscope with occasional researches with the spectroscope.

The elimination of nitrogen is of utmost importance because of its detrimental effect on the metal. Fortunately the contained quantities are very small and so their total effect is not very bad.

Nor do we know as to exactly what the total influence may be, although it is definitely known that it causes brittleness and cold shortness in exactly the same manner as phosphorus, except that it is estimated that the effect of nitrogen is nine times that of phosphorus, the quantities being the same.

Back of all this detail of manufacture lies the selection of raw materials, and this is done with even greater care than it was three years ago. This applies particularly to the scrap that is used. It has been found, for example, that the use of turnings, bought in the open market, is apt to introduce an excessive amount of copper into the bath, so that this class of material has been entirely discarded and no turnings are used in the manufacture of ingot iron. A limit is set to the allowable copper content which is put at .04 per cent., though, in practice, it usually falls to .03 per cent. or less, and this has become a part of the regular specification for the material. It is claimed that if a small amount of copper is introduced into steel, it may add to its rust resisting qualities provided the distribution throughout the mass is uniform, but that this distribution is difficult to obtain is evidenced by the fact that tests made from steels that have been intentionally treated with copper show wide variations in their tendencies to corrode, so that while good results may be obtained they are not reliable and to be depended upon. Hence, as it has been the aim of the company to produce a pure metal, the elimination of copper is considered to be one of the requisites of such a production.

This addition of the copper specification and limit has made the analysis of the metal much more elaborate than that ordinarily used. As it stands, the laboratory of the American Rolling Mill Company analyzes every heat, not only for the five ordinary impurities, carbon, silicon, manganese, phosphorus and sulphur, but for oxygen and copper in addition, with frequent tests for nitrogen.

Great stress is laid on the purity of the metal, and as stated in the previous article: "It furnishes the strongest support we have yet had on a large scale of the soundness of that somewhat complicated hypothesis—the electrolytic theory of corrosion. From time to time examples are brought to light of the remarkable resistance to corrosion of specimens of pure iron. Among these may be mentioned the links used in forming the suspension chain of a bridge at Newburyport, Mass. These links were exposed to all the vicissitudes of a New England seacoast climate for more than 100 years, and yet showed no appreciable corrosion. It is interesting to mark the close resemblance of the structure of this old iron to that of ingot iron as shown by the accompanying engravings, and to contrast the

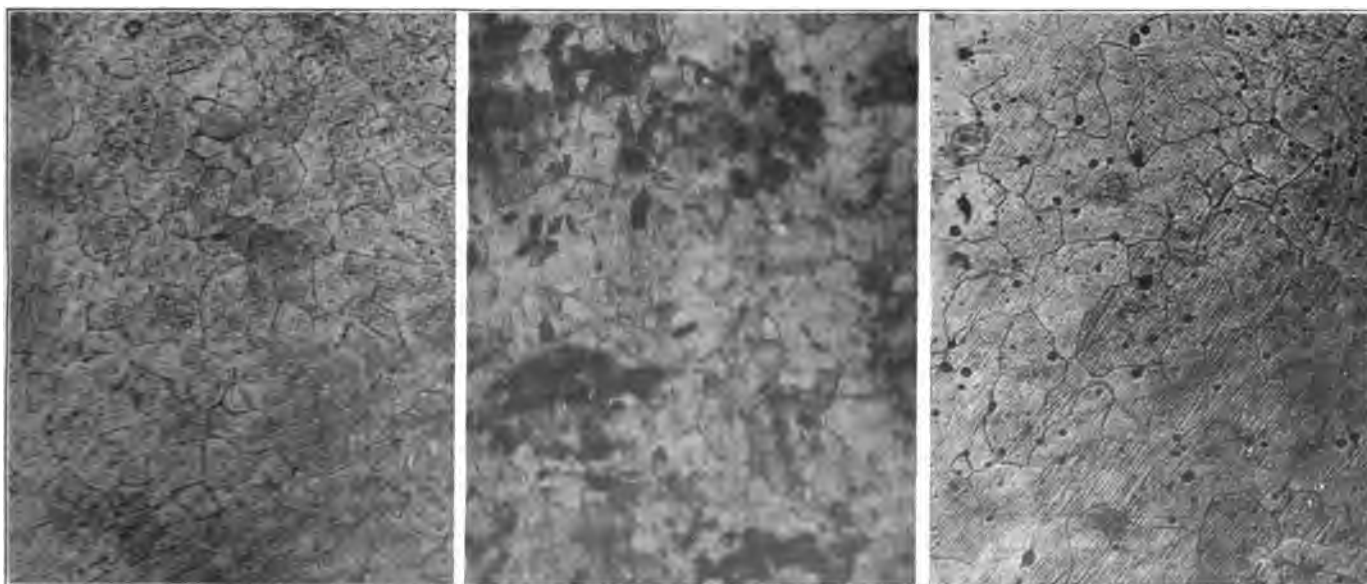

American Ingot Iron Transverse Section x-70.

Charcoal Iron Sheet Longitudinal Section x-70.

Newburyport Link Transverse Section x-70.

cleanliness and distinctness of the granular formation of these two metals with that of a piece of typical wrought iron in which streaks of slag are so much in evidence.

It is probable that this absence of slag as well as the low percentage of included gases has much to do with the increased density of ingot iron as compared with steel or even Norway iron. The specific gravity of steel may be taken at 7.84; of Norway iron of the grade used in the Newburyport bridge it is almost 7.95, while for the ingot iron it is 8.00. As to whether this increase of density has any influence on the behavior of the metal under various conditions of manipulation is not known, but it is, at least, reasonable to suppose that it has.

Besides its greater resistance to corrosion than steel, ingot iron shows a marked superiority to those older metals when subjected to galvanizing. There is not only a very marked difference in the appearance of galvanized sheet, but an equally marked difference in the resistance to wear. In appearance the spangles of zinc on an ingot iron sheet are large and cover the sheet with an almost uniform sheen. On steel the spangles are smaller and of great difference in brilliancy. The wearing qualities of galvanized steel sheets are also much less. The zinc coating seems to be more brittle and likely to flake off, and is much more susceptible to the action of corrosion. It has been found that ingot iron is much more durable when made into galvanizing tanks than is steel, and this because it is less soluble in the bath. This has been set forth as an explanation of the reason for the greater durability of galvanized sheets. The ingot iron being less soluble in the zinc than the steel, the layer of zinc-iron alloy, between the coating and the sheet, is thinner and yet thick enough to hold the two firmly together. With the steel the connecting alloy is not only thicker, and partakes of the nature of dross, but the coating itself is permeated with a larger per cent. of iron, which thus renders it more susceptible to corrosive action than obtains with the purer coating found on ingot iron. In like manner it has been found that ingot iron will take enamel coatings much more readily than steel, and that such coatings are much less likely to have pin holes when placed on the iron than when used on steel.

It has been known for a long time that there is a critical zone ranging from approximately 350 to 450 deg. Centigrade, where mild steel, such as that used for boiler plates, cannot be worked—that is, bent. Metal that can be bent flat on itself cold, or at a cherry red, will crack if any attempt is made to bend it at the blue temperature. So with ingot iron. There is a zone extending from about 800 to 1,000 deg. Centigrade in which it is unsafe to attempt to work it, and within this zone it is quite impossible to punch or bend it. Under ordinary handling, when within this zone, it will crack. Above or below it will stand the severest punishment. The method recommended for flanging, or similar pieces of work, is to raise it to a welding temperature and work rapidly until down to an orange, finishing before that temperature is reached, if possible. If this cannot be done allow the metal to stand until the critical zone is passed and then resume work. It is interesting to see a demonstration of this where the metal at the higher temperatures can be bent back and forth and badly maltreated without showing any crack or flaw. Then, suddenly, as the temperature enters the critical zone, it will begin to crack. Pieces will break off under very light blows of a hammer and this will continue until the zone is passed, when, with equal suddenness, the breaking will cease and the metal resumes the toughness and ability to resist bending that it had before. These are points that must be carefully observed by any one who wishes to work the metal successfully.

This characteristic shows itself to a very marked degree in rivets. Ingot iron rivets cannot be driven at a temperature above the critical zone, else they will crack as they are subjected to the cooling stresses in passing through it. But they can be driven very successfully below the zone and will head and hold perfectly. This simply means that they must be driven at a low temperature.

One of the marked and valuable features of ingot iron is the ease with which it can be welded. It is extensively used for making electrical transformer cases. These are stamped to shape and welded together with an acetylene torch, using another strip of ingot metal as a welding metal almost as though it were solder. It is also extensively used as a filling metal for autogenous welding and has been found to be far superior to the best Swedish bar for this purpose, because of its purity and freedom from slag.

In using the metal for this flowing-in process of welding it is, of course, always left or finished at an exceedingly high temperature. This seems to make no difference with the microscopic structure, and the grains set in symmetrical shape. Nor is there any appreciable effect on the tensile strength or elongation. But if it is subjected to cold rolling at a low temperature, the ultimate strength may be increased to 68,000 lbs., while the elongation may be cut down to 6½ per cent., whereas before the cold rolling or wire drawing it would stand at from 30 to 33 per cent. But, again, it is the purity of the metal on which its many applications depend. It is one of the few that meets the government requirements for tin plate, that the sheets shall not contain more than .03 per cent. of manganese, sulphur or carbon.

### THE STANDARD SCALE TESTING CAR OF THE U. S. BUREAU OF STANDARDS.

On July 1 an appropriation became available for the purchase of a scale car by the Bureau of Standards of the Department of Commerce in Washington for use in testing large scales and weighing machines. While the larger railway and industrial corporations have provided scale cars for testing the accuracies of their scales, many individual owners and users of scales have no means of verifying the correctness of the scales over which their business is transacted. To enable these scales to be properly tested as well as to provide a uniform test for all scales this car has been designed.

A car will be provided for housing and transporting the equipment proper. The main items of the equipment will consist of eight 10,000 lb. weights, four 2,500 lb. weights, 200 50 lb. weights and other smaller weights making a total of over 100,000 lbs. of test weights. Auxiliary equipment consisting of a motor driven truck will be provided for handling the weights, holding them during tests and carrying them from point to point on the platform of the track scales. A crane will also be provided for handling the weights and truck and for storing them for transportation. A gasolene engine driven 10 k. w. generator for supplying power, a storage battery, lights, office space and auxiliary equipment for studying the action of the mechanical parts of the scales will also be included on the car.

This equipment is being constructed by A. H. Emery, of Stamford, Conn., in accordance with the plans of L. A. Fischer, chief of division of weights and measures, Bureau of Standards, and C. A. Briggs of that bureau, who will have charge of the car. The construction work on this car is well advanced and the equipment will be ready for use about early fall.

Statistics of the number of wooden poles purchased in the United States in 1911 by steam and electric roads, electric light and power companies and telephone and telegraph companies are presented in a bulletin soon to be issued by the Bureau of the Census, Department of Commerce. The total purchases of poles for 1911 amounted to 3,418,020 sticks of timber of which 70.3 per cent. were purchased by telegraph and telephone companies and 6.7 per cent. by steam railroads. Cedar timber provided 61.4 per cent. of the total number of poles used, while the number of chestnut poles used has increased 177,440 since 1908. The number of oak poles decreased 65,000 from the preceding year. The use of pine has increased very little since 1907, while the demand for cypress has fallen off each year. Of the total number of poles, 159,321 were creosoted entirely or in part.

### AN ECONOMICAL TRAVELER FOR DISMANTLING A TRAIN SHED.

In connection with the reconstruction and enlargement of the passenger station of the Central Railroad of New Jersey at Jersey City and the construction of a new Bush train shed, it was necessary to remove the old high train shed. In the dismantling of this structure recently an interesting form of traveler was successfully used.

The old train shed was 512 ft. long and 142 ft. 7 in. wide, exclusive of extensions on each side 36 ft. 6 in. wide. The main portion of the shed spanned eight tracks and was carried by 16 trusses spaced 32 ft. between centers. The vertical reactions of these trusses were transmitted through hinged joints to vertical posts and the horizontal thrusts were carried by the cantilever extensions resting on brick walls as shown in the accompanying cross section. Because of this peculiarity of construction it became necessary to dismantle the main portion of the train shed first.

To remove this center portion a traveler was built up from three new signal bridges designed for use later on the main line. These bridges were of 109 ft. span and were spaced 15 ft. and 26 ft. respectively, between centers from the forward end. They were planked over solidly so that no material could drop through. Two hoisting engines and a boiler were placed over the rear bridge and two five ton stiff leg derricks with 40 ft. booms over the middle bridge. No equipment was placed on the forward bridge which supported the trusses during dismantling. The traveler was mounted on wheels running on

rails and was rolled from one span to the next. These bridges were erected and the equipment placed on them with a derrick car.

In dismantling the trusses the skylights and roof were re-

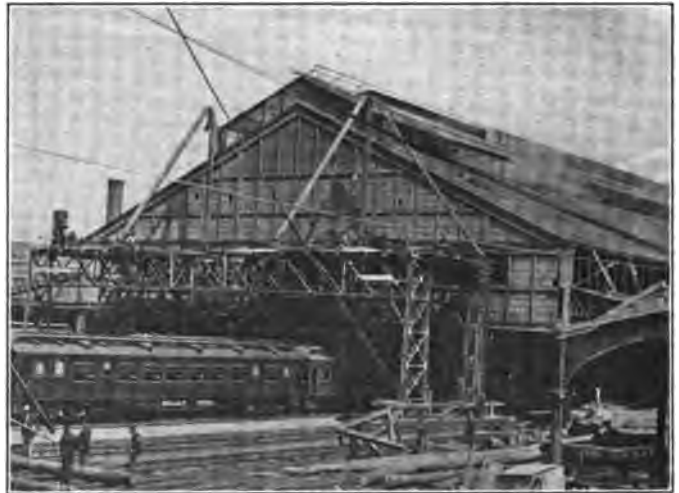

Traveler Erected Preparatory to Beginning Work on First Truss.

moved one panel ahead of the traveler after canvas had been stretched below to protect passengers from falling material. The order of procedure in removing a truss was to jack it up

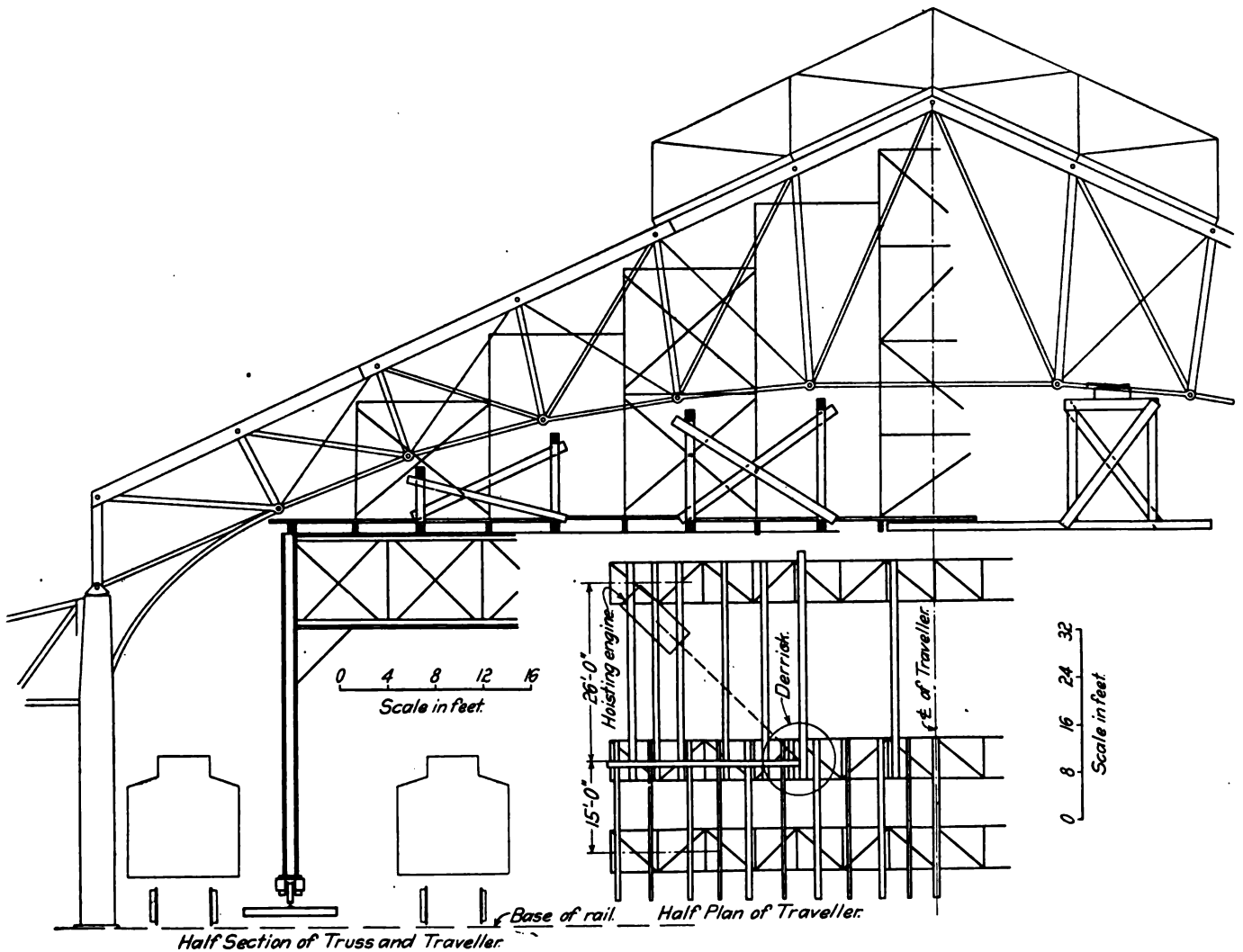

Half-Section of Traveler and Truss and Half-Plan of Traveler.

on blocking on the forward bridge, knock out the pins and cut the members at the splices with an oxy-acetylene flame. They were then lowered piece by piece by the derricks onto the platforms and then onto cars on tracks outside the traveler. After the last truss was dismantled the three signal bridges were



Dismantling of Train Shed Nearing Completion.

removed in two hours. After the platform, engine and derricks had been taken down, two 20 ton derricks picked up the bridges one at a time, moved them back 500 ft. and set them down. A large derrick then swung them around and loaded them on cars for removal.

This work was handled expeditiously and economically by this method without injury to anyone. After the work was well started an average of one truss per day was dismantled.

## AN EFFICIENT ORGANIZATION FOR BRIDGE AND BUILDING WORK.

BY M. RINEY,

Foreman, Bridges & Buildings, Chicago & North Western, Baraboo, Wis.

In the organization of an efficient bridge and building force the first essential is a competent foreman and a gang composed of reliable bridge men. These men should be located at some point on the subdivision where they can always be quickly reached in case of an emergency. The crews on each subdivision should be of sufficient size that they can keep up with their work without temporarily increasing forces at any time during the season, as the practice of rushing the season's work with a large force of men and then dismissing them in the fall, makes it very difficult to secure and hold competent men. It has been my experience that where one can keep men constantly employed the year round greater efficiency is secured.

The men should receive good compensation for the service and should be provided with good tool and bunk cars. They should also be supplied with gasoline motor cars so that they may be able to get over their respective territories more quickly than with old-style hand cars. I believe that gangs equipped with motor cars will show a saving of at least 20 per cent. in labor.

We have followed for many years the practice of furnishing the foreman of each subdivision with a copy of our bridge inspection report so that he will have a list of the work authorized for the coming season. The material for this work is stored and shipped out as ordered by each foreman so that the crews are not delayed waiting for material.

In the building department, by properly arranging the work, a crew of from five to seven men can take care of the repairs and renewals of buildings, water tanks, etc., being constantly on the lookout for minor repairs to station platforms, stock yards and water stations not authorized on the budget. The work should be arranged so as not to shift the men any oftener than necessary and all material for each job should be on the job before the work is started. At division headquarters the bridge department should have a shop equipped with steam or gasoline

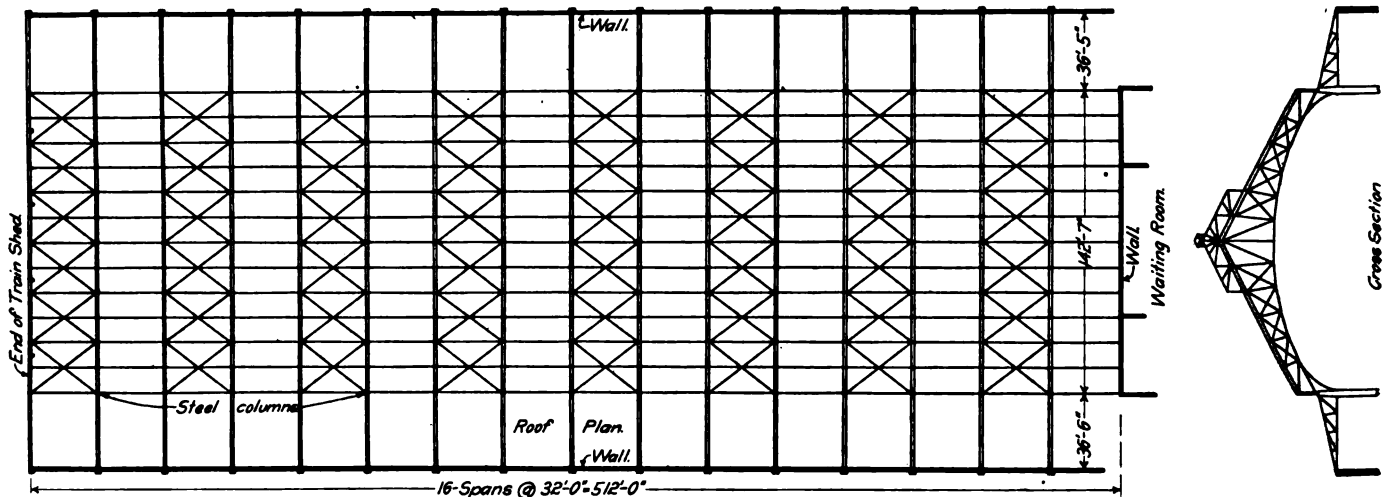

Plan and Cross-Section of Old Train Shed.

The traveler was erected on April 13, and after placing the equipment on it work was started on removing the end frames of the first truss on April 22. The last truss was removed on May 17, and the traveler was dismantled on May 21. As the signal bridges will be installed on the main line without alteration, the cost of a traveler, amounting to about \$4,200, was saved.

This work was handled under the direction of J. O. Osgood, chief engineer, A. E. Owen, principal assistant engineer, and J. J. Yates, bridge engineer. Terry & Tench, of New York, were the contractors.

power and with saws for cutting timber for routine repairs and for emergency work.

RAILROAD CONSTRUCTION IN ECUADOR.—The Manta to Santa Ana line has been under construction since the early months of 1911. Some 30 miles have been finished, and these are being opened to the public. About nine miles, yet to be built, will complete the railroad. So far the construction has cost the nation nothing. The concession stipulated that no payment of any kind was to be made to, or any obligation incurred by the federal government until the whole line was finished.

### CHESAPEAKE & OHIO YARD AT SILVER GROVE, KENTUCKY.

The new Chesapeake & Ohio classification yard at Silver Grove, Ky., about 12 miles east of Cincinnati, Ohio, was completed early last summer and has been successfully operated since that time. It was designed especially for classifying eastbound business as the yard at Russell, Ky., near the junction of the lines to Cincinnati and Louisville, handles the westbound classification. It was also badly needed to supply holding tracks for westbound business. The principal loaded move-

The site is closely adjacent to the Ohio river on low, level ground. The main line at this point is on a fill which averages 8 to 10 ft. high, the grade being fixed to keep the tracks above the highest water stage. To reduce the amount of grading necessary for the new yard, the yard level was fixed at a grade 3 ft. below the main line and all openings through the main line embankments were provided with valves to make those embankments serve as dikes for the yard site in extreme high water stages. The filling material for the yard was obtained from four borrow pits closely adjacent to the yard and consisted almost entirely of clay and loam. The fill required

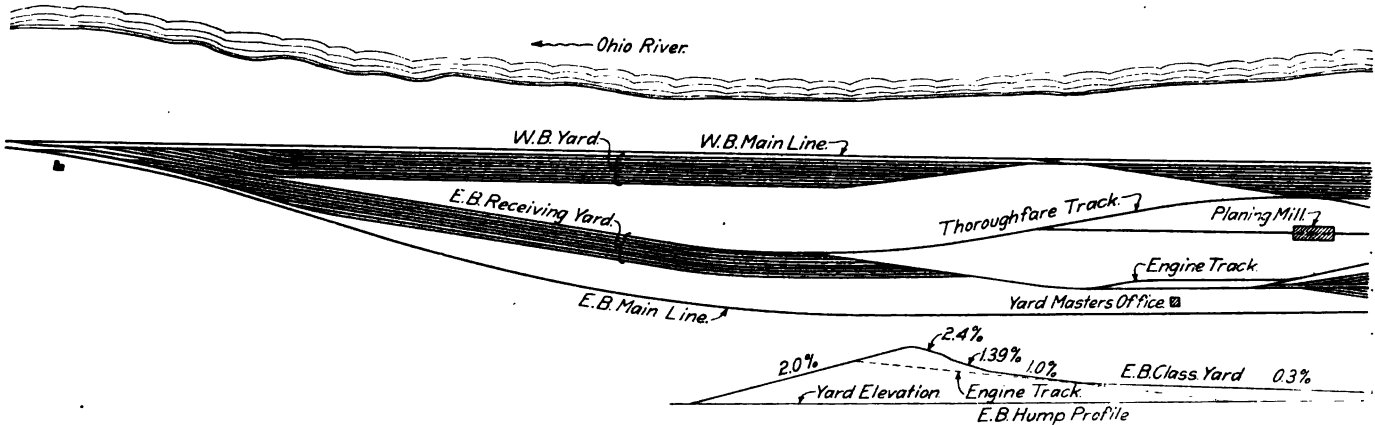

Track Plan of the Silver Grove Yard of the Chesapeake & Ohio.

ments eastbound through the new yard are grain and manifest freight. In addition to this class of traffic there are a very large number of empty coal cars returning to the eastern coal fields. The new yard will also handle a heavy transfer business for the Cincinnati district.

Since practically all the classification is eastbound, only one hump was built. The eastbound receiving yard is graded for 12 tracks and is laid with eight tracks 3,000 ft. long converging on a ladder leading to the hump from which the cars are dropped into a classification yard of 12 tracks each 3,770 ft.

1,100,000 cu. yds., the maximum height under the hump being about 18 ft. The material was handled in standard gage Kilbourne and Jacobs cars.

The hump profile, which is shown in the accompanying drawing, was adopted after careful study of existing yards that are operating successfully, the design being similar to that adopted a few years ago in building the yard at Russell. The approach is on a 2 per cent. grade; the accelerating grade off the hump is 2.4 per cent., with 40 ft. of 4 per cent., flattening to 1.39 per cent., then to 1 per cent., then to 0.3 per cent., and then to level

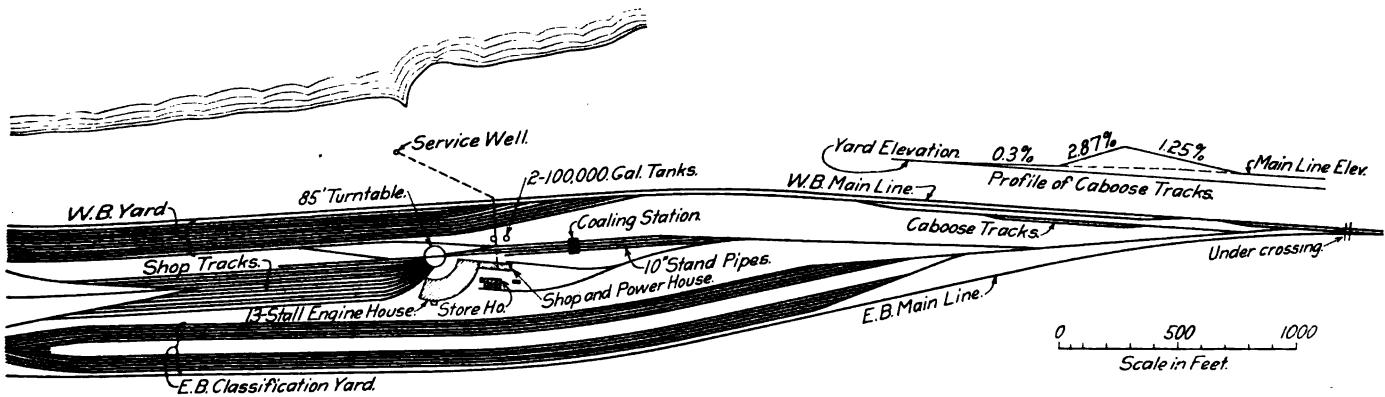

Track Plan of the Silver Grove Yard of the Chesapeake & Ohio (Continued).

long. The double ladder arrangement is used in the entrance to this classification yard, the middle tracks being spread to allow the addition of four more tracks when the traffic requires it. The westbound receiving yard has 10 tracks each 3,150 ft. long and the westbound classification yard has 10 tracks each 3,224 ft. long. In addition to these main yards there are 10 shop tracks and two caboose tracks, as well as thoroughfare tracks, engine tracks and necessary service tracks around the engine terminal. The eastbound main line is carried around the yard to eliminate switching movements across the main line in entering and leaving the yard.

in the yard. The hump engine used is a Mallet compound weighing 285,000 lbs. The yard is laid with 75 lb. rail on oak ties, the turnouts from the main line being No. 10 with spring frogs and the turnouts in the yard being No. 7. The total length of track in the yard is 35.06 miles.

A complete engine terminal is provided between the eastbound classification and the westbound receiving yard, which includes a 13 stall engine house of brick on concrete foundations, an 85 ft. turntable with electric tractor, a machine shop for running repairs to locomotives, a timber coaling station for coaling on three tracks which was designed by the C. W. Hunt Co.,

who also furnished the machinery, an electric power plant which contains three 150 h. p. Sterling boilers, one 185 k. w. generator and one 125 k. w. generator, the power being used for driving all machines in the shops and for lighting the buildings and yards. There is also a car shop for repairing all bad order cars, a storehouse, planing mill and a number of miscellaneous buildings.

The water supply is secured from a well opposite the roundhouse between the yard and the river. This well consists of a cylindrical concrete shaft 15 ft. in inside diameter, built continuously at the surface and jetted down to place. The bottom of this concrete well extends about 15 ft. below the low water level and the top is slightly above high water. To allow the water from the river to enter 5 in. drain pipes are set at close intervals through the wall and the seepage through the coarse sand and gravel is counted on to purify the water considerably for drinking purposes, although it probably will have little effect on its fitness for use in boilers. There are two electrically driven pumps with a capacity of 1,000,000 gal. in 24 hours which supply the water from this well to a 100,000 gal. storage tank at the yard and a similar tank for supplying the town which is planned for the employees.

The company has provided a hotel and eating house with more than 100 rooms for the convenience of trainmen and employees in the yard and shops. This building is located at a convenient point adjacent to the yard.

This yard was built under the supervision of F. I. Cabell, chief engineer. E. Gray was the assistant engineer in direct charge of the construction work. Westinghouse Church Kerr & Company had the contract for the buildings, and D. A. Langhorne & Co., Lynchburg, Va., handled the grading.

## A FRAME FOR CARRYING GLASS.

By C. H. THOMAS.

The accompanying sketch shows a simple frame for carrying panels of glass, which not only assists in protecting the glass,

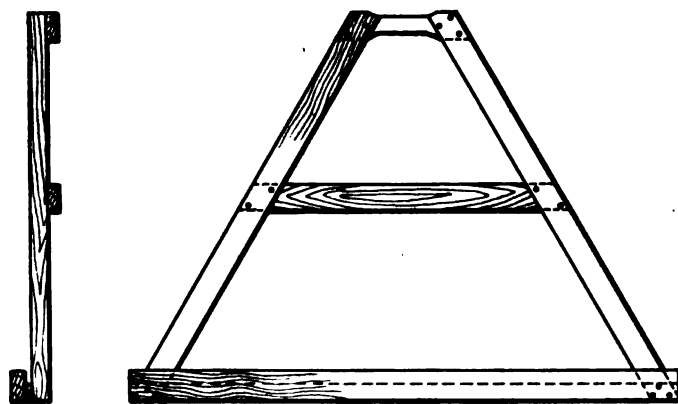

A Frame for Carrying Glass.

but also reduces the danger of minor injuries to the men. This frame is readily made from any suitable timber.

**SUPPLIES FOR THE TRANS-AUSTRALIAN RAILWAY.**—The construction of the Trans-Australian Railway, as well as other new lines throughout the Commonwealth, entails the local manufacture of large quantities of materials and appliances, also the importation of a number of spare parts, rails, tools, etc. Engineering representatives, particularly the German and American, are active in trying to secure orders. Many ship loads of materials have been and are on their way to Fremantle and Port Augusta, the landing points for the Trans-Australian line. Two steamers have recently landed 8,000 tons of rails, being an installment of the order recently secured by American steel manufacturers.

## General News.

The Mobile & Ohio has increased the pay of locomotive engineers, the average rate of increase being somewhat less than 5 per cent.

The Delaware, Lackawanna & Western has ordered the abolition of pens and inkstands in telegraph offices and the use of indelible pencils instead.

The passenger station, freight house and grain elevators of the Lake Erie & Western, at Kokomo, Ind., were destroyed by fire on July 6, causing a loss estimated at \$60,000.

The Interstate Commerce Commission has requested Congress to appropriate \$1,500,000, in the deficiency bill now being prepared, to pay a part of the expenses for valuing the property of the railroads of the country.

At Kansas City, July 16, William LaTrasse, a train robber, was sentenced to from one to twenty-one years in the penitentiary for robbery of a Missouri Pacific passenger train between Leavenworth and Kansas City in December, 1910.

The Texas & Pacific has announced that, effective July 1, its operating department will adopt the divisional plan of organization. All train masters have been appointed assistant superintendents. The assistant superintendent, master mechanic, division engineer, road master and foreman of bridges and building will all report to the superintendent.

The Chicago railways have announced that all freight houses in Chicago will be closed at 3 p. m., instead of 4:30 p. m. on Saturdays during July and August, following the plan adopted last year. The railways were in favor of giving the men all of Saturday afternoon, but this was opposed by shippers on the ground that it gave other cities an advantage over them.

Among the laws passed by the last legislature of Maine and which are now in effect are an act to amend the laws of 1911 requiring railroads to pay their employees weekly, instead of fortnightly; an act providing that railroad companies shall screen the windows of smoking cars from May 1 to November 1, on cars running through forest sections; an act looking to the abolition of highway grade crossings, and an act to regulate the size and construction of cabooses.

R. C. Richards, chairman of the Central Safety Committee of the Chicago & North Western, is furnishing to all the moving picture shows along the line of the road a set of stereopticon views similar to those shown in its trespass circular, showing the manner in which so many people are killed and injured while trespassing on railroad tracks. One of the slides used shows a statement giving the number of persons killed and injured while trespassing in the last 20 years.

The new public utilities act in Maine, noticed last week, was rendered inoperative, as was expected, by the filing of a petition for referendum, containing more than 10,000 names. It is expected that Governor Haines will soon announce the date for a general election to decide on the matter. Friends of the measure are organizing, and it is said that they will test the right of proponents or opponents of a measure to purchase signatures to referendum petitions which, it is charged, has been done in this case. Meanwhile, the present railway commission will continue in power.

Floods in Central Ohio on July 14 and 15 are said to have done damage amounting to \$3,000,000, the rainfall at many places amounting to over 6 in., or an amount nearly equal to that which fell in the disastrous flood of last March. At Zanesville more than twenty bridges were reported washed away. The Muskingum river rose 15 ft. in eight hours. Near Marietta a passenger train of the Pennsylvania was surrounded by water so suddenly that passengers had to be rescued in boats, and some of them are said to have been taken out of the cars through holes cut in the roofs. The fire in the locomotive was quenched so quickly that the engineman was unable to back away from the flood. The contents of the mail car and the baggage car were submerged. At last accounts railroad traffic, interrupted in many places, had been mostly resumed.

The Chicago city council committee on railway terminals has adjourned until October 1, by which time it is expected the

report of J. F. Wallace on the various proposed plans for railway terminal location will be ready to be submitted. Mr. Wallace is now engaged in making a study of the various plans. The City Club has sent a letter to the mayor and the city council protesting because the committee selected only one engineering expert instead of a commission of three or more, and offering to pay a part of the expense of employing such a commission. The Union Station Company has published another page advertisement in the Chicago papers, quoting a large number of letters from prominent Chicago business men opposing the idea of a single central passenger terminal, and favoring the location proposed by the railways on the west side.

At a dinner at the Hotel Astor, New York City, July 9, about 150 railroad men celebrated the thirtieth anniversary of the opening of the first division of the New York, West Shore & Buffalo, now the River division of the New York Central. Representative railroad men from Maine to the Missouri Valley and from the South were in attendance. The guest of honor was Charles W. Bradley, seventy-five years old, who was the first of the minor employees to be made a general officer of the company. He is now the superintendent of telegraph of the Chesapeake & Ohio. Among those who made speeches were: John B. Kerr, vice-president of the New York, Ontario & Western; J. McCulloch, of the New York Telephone Company; F. E. Harriman, local traffic manager of the New York Central; J. H. Hustis, vice-president of the New York Central; C. D. McKelvey, inspector for the New Jersey Public Utility Commission; Ira A. Place, vice-president of the New York Central; Walter B. Pollock, manager marine department, New York Central, and Percy R. Todd, president of the Bangor & Aroostook.

#### Fourteen Passengers Killed in California.

A press despatch from Los Angeles, Cal., July 13, reports that in a rear collision on the line of the Pacific Electric Railway, at Vineyard station, near Los Angeles, on the evening of that day, fourteen passengers were killed and a large number injured, probably over 150. Three trains from the beach, bound for Los Angeles, had followed each other, one after the other, closely, when all three were stopped, for some reason not explained. The third train appears to have been started on an improper signal, or through misunderstanding, and it crashed into the second one. The conductor of the standing train claims that he waved a red lantern in ample time to stop the third one.

#### U. S. Safety Appliances Required in Canada.

The Board of Railway Commissioners for Canada issued, on July 9, a code of regulations requiring cars in the Dominion to be equipped with safety appliances corresponding to those called for by the standards prescribed by the Interstate Commerce Commission of the United States. All railroads in Canada are called upon to complete the necessary changes in their cars and engines by December 31, 1915. These rules refer to hand brakes, brake-steps, running boards, sill-steps, ladders, hand-holds, uncoupling levers, etc.

#### A Safety Exposition in December.

The first international exposition of Safety and Sanitation ever held in America will be held in New York City, December 11 to 20, 1913, under the auspices of The American Museum of Safety, 29 West Thirty-ninth street. Safety and health in every branch of industrial life, manufacturing trade, transportation, business and engineering, in all of their sub-divisions will be represented at this exposition. By a special act of Congress, exhibits from foreign countries are to be admitted free of duty. European employers have cut their accident and death rate in half by a persistent campaign for safety. There are 21 museums of safety in Europe. All of these will contribute to the exposition.

#### Disturbances Concerning Wages.

The demand of the conductors and brakemen which is being considered at New York is not the only news item concerning the pay of railroad employees. The Central Vermont, which is not a party to the negotiations in New York, has been called upon by its enginemen and firemen for an increase of 20 per cent. Officers of the brotherhood are conferring with the general manager at St. Albans. Last week it was reported that about

800 shopmen employed by the Philadelphia & Reading had been dismissed because of a strike; but on Tuesday of this week a press despatch from Washington says that Acting Commissioner Hangar from the Department of Labor has adjusted the strike of "several thousand carmen on the Philadelphia & Reading, acting in conjunction with the Pennsylvania State Bureau of Labor and Industry." At Philadelphia it is announced that the Reading has adjusted the pay of despatchers, yardmasters and agents, to put the rates of their pay on a parity with those of other classes, to whom increases have lately been granted. A press despatch from San Francisco, July 15, says that conductors, brakemen and yardmen on the electric lines of the Southern Pacific, on the east side of San Francisco bay, more than 5,000 men altogether, want increases in their pay, to put them on a level with the men of the same classes who are working on steam-operated lines. The unions of the employees are said to be taking a strike vote.

#### Promotion of Enginemen on the New Haven.

The New York, New Haven & Hartford has made public the following new order regulating the assignment of engineers to passenger trains:

"Enginemen must not be permitted to operate passenger trains except under the following conditions:

"First: They must have two years' previous road experience for through trains and one year's previous road experience for local trains.

"Second: They must have a certificate showing that they have passed all of the required examinations, a watch certificate, and a certificate of competency based upon the personal observation and knowledge of the road foreman of engines and master mechanic and approved by the division superintendent. A copy of this certificate must be given to the engineer and a copy filed in the division records.

"Third: No engineer must be assigned to passenger trains without the prescribed service qualifications or certificate of competency, unless he is accompanied by a road foreman of engines or other competent employee, who will remain with, and be responsible for him until his competency is established.

"Fourth: No man will be promoted to the position, or employed as an engineer, or take rating as such, until he is furnished with the prescribed certificate of competency from the road foreman of engines and master mechanic and approved by the division superintendent; a copy of this certificate to be filed in the division records."

#### Trainmen's Wages.

The leaders of the conductors' and brakemen's brotherhoods, conferring in New York City, had with them on Saturday last about 900 representatives of the local organizations who, at the end of a long meeting, ratified the votes which had been taken authorizing the leaders to order a strike on the eastern railroads, if deemed necessary. No action was taken by the leaders, however, pending the conference held at Washington on Monday in the office of President Wilson; and at that conference an agreement was reached, concurred in by all interested, for the prompt passage of the Newlands bill, amending the federal arbitration law. Congress passed and the president signed this bill on Tuesday, the 15th. The bill was passed in substantially the form in which it was given in the *Railway Age Gazette* of June 13, two amendments inserted in the house having dealt only with details. The president expressed his intention of acting as soon as possible in the matter of appointing a commissioner of mediation and an assistant commissioner. On Monday, Elisha Lee, chairman of the railroad managers' committee, had notified the leaders of the employees that if the Newlands bill should be passed the managers would be willing to submit to arbitration all questions of rates of pay and working conditions.

It is hinted that when the matter of brakemen's wages comes up for discussion under an arbitration agreement the railroads will propose that the extra brakemen made necessary by full crew laws, shall be paid less than the men who have useful duties to perform.

A statement has been issued showing what conductors and trainmen receive on the New York Central. On through passenger trains running between New York and Buffalo, requiring from 165 to 194 hours per month, the pay is: Conductors, \$168



to \$189 per month; trainmen, \$94 to \$108 per month. Baggage-men working between New York and Buffalo, from 170 to 191 hours per month, receive from \$95 to \$122 per month. On division passenger runs, such as those between New York and Albany, Albany and Syracuse, and Syracuse and Buffalo, requiring from 162 to 251 hours per month, the pay is: Conductors, \$130 to \$163 per month; trainmen, \$74 to \$93 per month. In suburban service, such as that in the vicinity of New York City within the electric territory, requiring from 123 to 212 hours per month, the pay is: Conductors, \$125 to \$156 per month; trainmen, \$70 to \$89 per month. In through freight service, conductors are paid from \$100 to \$150 per month; brakemen from \$75 to \$100 per month.

On Wednesday the railroads and the labor leaders telegraphed from New York to President Wilson that they desired the services of the new Commissioner of Mediation as soon as practicable. Later the managers' committee notified the employees that the roads themselves would have some claims to lay before the proposed arbitration board, which claims are outlined as follows:

When a minimum day's wage is paid in any class of service it shall entitle the railroad to the full mileage or hours of service paid for.

In no case shall double compensation be paid.

For fixing the basis of compensation, i. e., whether passenger, through or local freight, yard, etc.—the same classification shall be applied to all members of the train crew.

All monthly guarantees shall be abolished.

That consideration be given to a reduction of existing rates of pay of yard brakemen and of passenger conductors and trainmen on long continuous runs where there is an opportunity to make excessive mileage in a limited number of hours.

Employees in two or more classes of service on continuous duty or under continuous pay shall be paid the rates applicable to the different services performed with a minimum equal to ten (10) hours at the lowest paid service.

On passenger and freight trains, where under extra crew laws, additional men are required, the rate of pay for all brakemen shall be 20 per cent. below rates established for brakemen on trains not affected by such laws.

The rates and rules awarded by this arbitration shall supersede rates and rules now in effect which are in conflict therewith.

#### Exhibitors at the General Foremen's Convention.

Among the exhibitors at the convention of the International Railway General Foremen's Association, held at the La Salle Hotel, Chicago, July 15-18, were the following:

- American Steel Foundries, Chicago.—Models of couplers, Economy draft arms, brake beams, Vulcan truck, Susemihl roller side bearings, Davis cast steel wheels. Represented by W. C. Walsh and W. G. Wallace.
- Anchor Packing Company.—Tauril sheet, superheat discs, general packings. Represented by E. C. Adams and J. B. Robb.
- Ashton Valve Company, Boston, Mass.—Locomotive safety valves, steam, air and test gages, wheel pressed recording gage, gage testers and appliances. Represented by Jos. F. Gettrust.
- Barco Brass & Joint Company, Chicago.—Flexible joints, roundhouse blower sets and washout connections. Represented by F. N. Bard.
- Bettendorf Company, Davenport, Iowa.—Truck and composite underframe. Represented by J. G. Hope.
- Bowser, S. F., & Company, Ft. Wayne, Ind.—Pumps and oil tanks. Represented by J. L. Handy.
- Buda Company, Chicago.—Buda-Ross electric headlight. Represented by Mark A. Ross.
- Carborundum Company, Niagara Falls, N. Y.—Carborundum and aloxite wheels and aloxite and carborundum cloths and valve grinding compounds. Represented by C. C. Schumaker, R. H. Hogg and A. H. Hanlon.
- Celfor Tool Company, Buchanan, Mich.—Drills, reamers, flue cutters, boring tools, etc. Represented by W. Nohumson and C. O. Montague.
- Chicago Pneumatic Tool Company, Chicago.—Air and electric drills, pneumatic hammers, speed recorders. Represented by C. E. Walker, P. F. Flaven, J. C. Campbell, J. L. Camby, C. B. Coates and Chas. H. Schumasken.
- Cleveland Twist Drill Company, Cleveland, Ohio.—Twist drills, and reamers. Represented by H. S. White.
- Crane & Company, Chicago.—Pipe fittings, valves and safety valves. Represented by G. S. Turner.
- Detroit Lubricator Company, Detroit, Mich.—Lubricators. Represented by A. D. Homard and R. H. Lindman.
- Emery Pneumatic Lubricator Company, St. Louis, Mo.—Emery brake cylinder lubricant, automatic lubricators, packing leathers showing results. Represented by E. A. Emery and H. C. Miller.
- Flannery Bolt Company, Pittsburgh, Pa.—Tate flexible staybolt. Represented by R. R. Davis.
- Garlock Packing Company, Palmyra, N. Y.—Throttle, cab cock and air pump packing. Represented by J. P. Landreth.

- Goldschmidt Thermit Company, New York.—Thermit welding compounds and sample welds. Represented by H. S. Mann, C. D. Young and H. D. Kelly.
- Hunt-Spiller Manufacturing Corporation, Boston, Mass.—Gray irons for cylinder bushings, packing, valve gages, boxes, etc. Represented by J. M. Mourse and B. W. Ellett.
- Independent Pneumatic Tool Company, Chicago.—New electric tools, new air turbines, small S. S. compound drills. Represented by Robert T. Scott, George Wilson, Fred. Passino and Harold Hendricks.
- Jenkins Bros., New York.—Globe, Angle Y and check valves, standard medium pressure and extra heavy gates. Represented by B. J. Neely.
- Jerguson Manufacturing Company, Boston, Mass.—Water gages. Represented by H. M. Waters.
- Locomotive Superheater Company, New York.—Boiler tools and unit distributing Prosser gages. Represented by R. M. Osterman and F. A. Schaff.
- McQuay-Norris Manufacturing Company, St. Louis, Mo.—Leakproof piston rings. Represented by H. G. Paro and C. R. Travis.
- Manning, Maxwell & Moore, Inc.; Ashcroft Manufacturing Company; Consolidated Safety Valve Company; the Hancock Inspirator Company, New York.—Hancock inspirators, boiler checks, Consolidated safety valves, Ashcroft pressure gages, Prismatic water glasses and other locomotive appliances. Represented by C. L. Brown.
- Mudge & Company, Chicago.—Mudge-Slater spark arrester. Represented by S. S. Lawson and G. W. Benden.
- Nathan Manufacturing Company, New York.—Lubricators, water glasses and valves. Represented by A. S. Work and George Royal.
- National Machinery Company, Tiffin, Ohio.—Single motor driven bolt cutter and die sharpener. Represented by Chas. Harmon, Jr. and K. L. Ernst.
- O'Malley-Bear Valve Company, Chicago.—Multiplate, Globe, Angle, check and blowout valves. Represented by E. O'Malley and Thos. O'Malley.
- Ohio Injector Company, Detroit, Mich.—Injectors, lubricators, flange oilers and boiler fittings. Represented by Wm. S. Furry, F. W. Edwards and A. C. Beckwith.
- Pyle-National Electric Headlight Company, Chicago.—Electric headlights. Represented by Guy H. Matthews.
- Racine Tool & Machine Company, Racine, Wis.—High speed metal cutting machines. Represented by J. M. Jones, W. L. Candee and Fred. Thonnis.
- Ryerson, Joseph T., & Son, Chicago.—Model of a punch and boiler tools. Represented by L. H. Bryan, C. R. Gregg, H. C. Williamson and H. G. Merriell.
- Skinner Chuck Company, New Britain, Conn.—Lathe and drill chucks, drill press vises, arbors. Represented by W. S. Rand.
- Standard Tool Company, Cleveland, Ohio.—General line of drills, reamers, taps and milling cutters. Represented by Frank Arnham.
- Strong-Charlisle & Hammond Company, Cleveland, Ohio.—Randall graphite sheet lubricator, Mac-it set screws. Represented by H. P. Prescott, W. G. Yates and B. E. Carpenter.

#### American Society of Engineer Draftsmen.

At the last meeting of the American Society of Engineer Draftsmen, held in New York, July 17, William F. Turnbull of the American Locomotive Company, New York, gave a lecture on The Mathematics of Structural Steel Construction.

#### MEETINGS AND CONVENTIONS.

The following list gives names of secretaries, dates of next or regular meetings, and places of meeting.

- AIR BRAKE ASSOCIATION.—F. M. Nellis, 53 State St., Boston, Mass.
- AMERICAN ASSOCIATION OF DEMURRAGE OFFICERS.—A. G. Thomason, Boston, Mass. Convention, May 19, 1914, St. Louis.
- AMERICAN ASSOCIATION OF GENERAL PASSENGER AND TICKET AGENTS.—W. C. Hope, New York. Annual meeting, October 14-15, Philadelphia, Pa.
- AMERICAN ASSOCIATION OF FREIGHT AGENTS.—R. O. Wells, East St. Louis, Ill.
- AMERICAN ASSOCIATION OF RAILROAD SUPERINTENDENTS.—E. H. Harman, St. Louis, Mo.; 3d Friday of March and September.
- AMERICAN ELECTRIC RAILWAY ASSOCIATION.—H. C. Donecker, 29 W. 39th St., New York.
- AMERICAN ELECTRIC RAILWAY MANUFACTURERS' ASSOC.—H. G. McConaughy, 165 Broadway, New York. Meetings with Am. Elec. Ry. Assoc.
- AMERICAN RAILWAY ASSOCIATION.—W. F. Allen, 75 Church St., New York. Next meeting, November 19, 1913, Chicago.
- AMERICAN RAILWAY BRIDGE AND BUILDING ASSOCIATION.—C. A. Lichty, C. & N. W., Chicago. Convention, October 21-24, 1913, Montreal.
- AMERICAN RAILWAY ENGINEERING ASSOCIATION.—E. H. Fritch, 900 S. Michigan Ave., Chicago.
- AMERICAN RAILWAY MASTER MECHANICS' ASSOCIATION.—J. W. Taylor, Old Colony building, Chicago.
- AMERICAN RAILWAY TOOL FOREMEN'S ASSOCIATION.—A. R. Davis, Central of Georgia, Macon, Ga. Next convention, July 22-24, Chicago.
- AMERICAN SOCIETY FOR TESTING MATERIALS.—Prof. E. Marburg, University of Pennsylvania, Philadelphia, Pa.
- AMERICAN SOCIETY OF CIVIL ENGINEERS.—C. W. Hunt, 220 W. 57th St., New York; 1st and 3d Wed., except June and August, New York.
- AMERICAN SOCIETY OF ENGINEERING CONTRACTORS.—J. R. Wenlinger, 11 Broadway, New York; 2d Tuesday of each month, New York.
- AMERICAN SOCIETY OF MECHANICAL ENGINEERS.—Calvin W. Rice, 29 W. 39th St., New York.
- AMERICAN WOOD PRESERVERS' ASSOCIATION.—F. J. Angier, B. & O., Baltimore, Md. Next convention, January 20-22, 1914, New Orleans, La.
- ASSOCIATION OF AMERICAN RAILWAY ACCOUNTING OFFICERS.—C. G. Phillips, 143 Dearborn St., Chicago. Annual meeting, May 28, Atlantic City, N. J.
- ASSOCIATION OF RAILWAY CLAIM AGENTS.—J. R. McSherry, C. & E. I., Chicago.
- ASSOCIATION OF RAILWAY ELECTRICAL ENGINEERS.—Jos. A. Andreucetti, C. & N. W. Ry., Chicago. Annual convention, October 18-24, Chicago.
- ASSOCIATION OF RAILWAY TELEGRAPH SUPERINTENDENTS.—P. W. Drew, 112 West Adams St., Chicago.

# Traffic News.

ASSOCIATION OF TRANSPORTATION AND CAR ACCOUNTING OFFICERS.—G. P. Conard, 75 Church St., New York.

ASSOCIATION OF WATER LINE ACCOUNTING OFFICERS.—W. R. Evans, Chamber of Commerce, Buffalo, N. Y. Annual meeting, October 8, Philadelphia, Pa.

BRIDGE AND BUILDING SUPPLY MEN'S ASSOCIATION.—H. A. Neally, Joseph Dixon Crucible Co., Jersey City, N. J. Meeting with American Railway Bridge and Building Association.

CANADIAN RAILWAY CLUB.—James Powell, Grand Trunk Ry., Montreal, Que.; 2d Tuesday in month, except June, July and Aug., Montreal.

CANADIAN SOCIETY OF CIVIL ENGINEERS.—Clement H. McLeod, 413 Dorchester St., Montreal, Que.; Thursday, Montreal.

CAR FOREMEN'S ASSOCIATION OF CHICAGO.—Aaron Kline, 841 North 50th Court, Chicago; 2d Monday in month, Chicago.

CENTRAL RAILWAY CLUB.—H. D. Vought, 95 Liberty St., New York; 2d Thurs. in Jan. and 2d Fri. in March, May, Sept., Nov., Buffalo, N. Y.

CIVIL ENGINEERS' SOCIETY OF ST. PAUL.—L. S. Pomeroy, Old State Capitol building, St. Paul, Minn.; 2d Monday, except June, July, August and September, St. Paul.

ENGINEERS' SOCIETY OF PENNSYLVANIA.—E. R. Dasher, Box 704, Harrisburg, Pa.; 1st Monday after 2d Saturday, Harrisburg, Pa.

ENGINEERS' SOCIETY OF WESTERN PENNSYLVANIA.—E. K. Hiles, Oliver building, Pittsburgh; 1st and 3d Tuesday, Pittsburgh, Pa.

FREIGHT CLAIM ASSOCIATION.—Warren F. Taylor, Richmond, Va.

GENERAL SUPERINTENDENTS' ASSOCIATION OF CHICAGO.—E. S. Koller, 226 W. Adams St., Chicago; Wed. preceding 3d Thurs., Chicago.

INTERNATIONAL RAILWAY CONGRESS.—Executive Committee, 11, rue de Louvain, Brussels, Belgium. Convention, 1915, Berlin.

INTERNATIONAL RAILWAY FUEL ASSOCIATION.—C. G. Hall, 922 McCormick building, Chicago.

INTERNATIONAL RAILWAY GENERAL FOREMEN'S ASSOCIATION.—Wm. Hall, 829 West Broadway, Winona, Minn.

INTERNATIONAL RAILROAD MASTER BLACKSMITHS' ASSOCIATION.—A. L. Woodworth, Lima, Ohio. Annual meeting, August 18, Richmond, Va.

MAINTENANCE OF WAY & MASTER PAINTERS' ASSOCIATION OF THE UNITED STATES AND CANADA.—W. G. Wilson, Lehigh Valley, Easton, Pa.

MASTER BOILER MAKERS' ASSOCIATION.—Harry D. Vought, 95 Liberty St., New York.

MASTER CAR BUILDERS' ASSOCIATION.—J. W. Taylor, Old Colony building, Chicago.

MASTER CAR AND LOCOMOTIVE PAINTERS' ASSOC. OF U. S. AND CANADA.—A. P. Dane, B. & M., Reading, Mass. Annual meeting, September 9-12, Ottawa, Can.

NATIONAL RAILWAY AFFLIANCE ASSOC.—Bruce V. Crandall, 537 So. Dearborn St., Chicago. Meetings with Am. Ry. Eng. Assoc.

NEW ENGLAND RAILROAD CLUB.—W. E. Cade, Jr., 683 Atlantic Ave., Boston, Mass.; 2d Tuesday in month, except June, July, Aug. and Sept., Boston.

NEW YORK RAILROAD CLUB.—H. D. Vought, 95 Liberty St., New York; 3d Friday in month, except June, July and August, New York.

NORTHERN RAILROAD CLUB.—C. L. Kennedy, C. & St. P., Duluth, Minn.; 4th Saturday, Duluth.

PEORIA ASSOCIATION OF RAILROAD OFFICERS.—M. W. Rotchford, Union Station, Peoria; 2d Thursday.

RAILROAD CLUB OF KANSAS CITY.—C. Manlove, 1008 Walnut St., Kansas City, Mo.; 3d Friday in month, Kansas City.

RAILWAY BUSINESS ASSOCIATION.—Frank W. Noxon, 2 Rector St., New York. Annual dinner, second week in December, 1913, New York.

RAILWAY CLUB OF PITTSBURGH.—J. B. Anderson, Penna. R. R., Pittsburgh, Pa.; 4th Friday in month, except June, July and August, Pittsburgh.

RAILWAY ELECTRICAL SUPPLY MANUFACTURERS' ASSOC.—J. Scribner, 1021 Monadnock Block, Chicago. Meetings with Assoc. Ry. Elec. Engrs.

RAILWAY GARDENING ASSOCIATION.—J. S. Butterfield, Lee's Summit, Mo. Next meeting, August 12-15, Nashville, Tenn.

RAILWAY DEVELOPMENT ASSOCIATION.—W. Nicholson, Kansas City Southern, Kansas City, Mo.

RAILWAY SIGNAL ASSOCIATION.—C. C. Rosenberg, Bethlehem, Pa. Convention, October 14, Nashville, Tenn.

RAILWAY STOREKEEPERS' ASSOCIATION.—J. P. Murphy, Box C, Collinwood, Ohio.

RAILWAY SUPPLY MANUFACTURERS' ASSOC.—J. D. Conway, 2135 Oliver bldg., Pittsburgh, Pa. Meetings with M. M. and M. C. B. Assocs.

RAILWAY TEL. AND TEL. AFFLIANCE ASSOC.—W. E. Harkness, 284 Pearl St., New York. Meetings with Assoc. of Ry. Teleg. Sups.

RICHMOND RAILROAD CLUB.—F. O. Robinson, Richmond, Va.; 2d Monday except June, July and August.

ROADMASTERS' AND MAINTENANCE OF WAY ASSOCIATION.—L. C. Ryan, C. & N. W., Sterling, Ill. Convention, September 8-12, 1913, Chicago.

ST. LOUIS RAILWAY CLUB.—B. W. Frauenthal, Union Station, St. Louis, Mo.; 2d Friday in month, except June, July and Aug., St. Louis.

SIGNAL AFFLIANCE ASSOCIATION.—F. W. Edmonds, 3868 Park Ave., New York. Meetings with annual convention Railway Signal Association.

SOCIETY OF RAILWAY FINANCIAL OFFICERS.—C. Nyquist, La Salle St. Station, Chicago.

SOUTHERN ASSOCIATION OF CAR SERVICE OFFICERS.—E. W. Sandwich, A. & W. P. Ry., Montgomery, Ala.

SOUTHERN & SOUTHWESTERN RAILWAY CLUB.—A. J. Merrill, Grant bldg., Atlanta, Ga.; 3d Thurs., Jan., March, May, July, Sept., Nov., Atlanta.

TOLEDO TRANSPORTATION CLUB.—J. G. Macomber, Woolson Spice Co., Toledo, Ohio; 1st Saturday, Toledo.

TRACK SUPPLY ASSOCIATION.—W. C. Kidd, Ramapo Iron Works, Hillsburn, N. Y. Meeting with Roadmasters' and Maintenance of Way Association.

TRAFFIC CLUB OF CHICAGO.—W. H. Wharton, La Salle Hotel, Chicago.

TRAFFIC CLUB OF NEW YORK.—C. A. Swope, 290 Broadway, New York; last Tuesday in month, except June, July and August, New York.

TRAFFIC CLUB OF PITTSBURGH.—D. L. Wells, Erie, Pittsburgh, Pa.; meetings monthly, Pittsburgh.

TRAFFIC CLUB OF ST. LOUIS.—A. F. Versen, Mercantile Library building, St. Louis, Mo. Annual meeting in November. Noonday meetings October to May.

TRAIN DESPATCHERS' ASSOCIATION OF AMERICA.—J. F. Mackie, 7042 Stewart Ave., Chicago.

TRANSPORTATION CLUB OF BUFFALO.—J. M. Sells, Buffalo; first Saturday after first Wednesday.

TRANSPORTATION CLUB OF DETROIT.—W. R. Hurley, L. S. & M. S., Detroit, Mich.; meetings monthly.

TRAVELING ENGINEERS' ASSOCIATION.—W. O. Thompson, N. Y. C. & H. R., East Buffalo, N. Y. Annual meeting, August, 1913, Chicago.

UTAH SOCIETY OF ENGINEERS.—R. B. Ketchum, University of Utah, Salt Lake City, Utah; 3d Friday of each month, except July and August.

WESTERN CANADA RAILWAY CLUB.—W. H. Rosevear, P. O. Box 1707, Winnipeg, Man.; 2d Monday, except June, July and August, Winnipeg.

WESTERN RAILWAY CLUB.—J. W. Taylor, Old Colony building, Chicago; 3d Tuesday of each month, except June, July and August.

WESTERN SOCIETY OF ENGINEERS.—J. H. Warder, 1735 Monadnock Block, Chicago; 1st Monday in month, except July and August, Chicago.

The Southwestern Passenger Association has announced that the sale of mileage books throughout the southwest will cease at once with the introduction of the two-cent fares.

The Denver & Rio Grande has announced that careful estimates indicate this year's output of the fruit growing section on the western slope of Colorado will approximate 12,000 carloads.

The secretary of agriculture has ordered a quarantine of the territory in the New England states infested with the gipsy moth and brown tail moth, under which Christmas trees and many other forest plant products can be transported out of the infested districts only after inspection by officers of the Department. By the terms of this order, lumber, ties, posts and poles will have to be inspected.

The western railways have announced that, on August 1, a team track storage charge assessed against shippers and consignees for failure to load or unload cars on team tracks within 48 hours, is to be made effective throughout the Western Trunk Line territory. Such a charge has been in effect in Chicago since August 1, 1912, and has resulted in a material decrease in the detention of cars. The charge is in addition to the demurrage, and is at the rate of \$1 per day for the first two days after the expiration of free time, and \$2 for each succeeding day.

The railroads in Official Classification territory have decided to at once file tariffs making a general advance of 5 per cent. in freight rates, both class and commodity, without waiting for the Interstate Commerce Commission's investigation, which is to come in the autumn. This action is taken in order to have a definite issue before the commission. The Central Freight Association has been in session this week in Chicago working out the details of the tariffs, and meetings of the Trunk Line Association have been held in New York for the same purpose. The rate makers are including the necessary adjustments to preserve the differentials between the Atlantic ports. It is hoped to make the tariffs effective September 1.

The National classification committee of lumber, wooden boxes and allied interests, representing six different associations, has filed with the Interstate Commerce Commission a petition asking the commission to rescind all rules and regulations in Western, Official, Southern and Transcontinental classifications which accord articles packed in fiber board, pulp board and corrugated board packages a parity of rating with articles shipped in wooden boxes. All of the railways that are members of the various classification committees are made defendants. This is the latest move in a long-drawn-out controversy between the makers of wooden boxes and those who make substitutes for wooden boxes, which was begun last year with the filing of a complaint by the R. W. Pridham Company of Los Angeles, against the transcontinental railways, which on eastbound shipments from California charge 25 per cent. higher rates on articles packed in fiber board boxes.

## Car Surpluses and Shortages.

Arthur Hale, chairman of the committee on relations between railroads of the American Railway Association, in presenting statistical bulletin No. 147, giving a summary of car surpluses and shortages by groups from March 27, 1912, to June 30, 1913, says: The total surplus on June 30, 1913, was 70,740 cars; on June 14, 1913, 71,126 cars; and on July 4, 1912, 70,731 cars. Compared with the preceding period: there is a decrease in the total surplus of 386 cars, of which 188 is in flat, 43 in coal, 1,660 in miscellaneous, and an increase of 1,505 in box car surplus. The decrease in flat car surplus is in groups 2 (New York, New Jersey, Delaware, Maryland and Eastern Pennsylvania), 7 (Montana, Wyoming, Nebraska and the Dakotas), 8 (Kansas, Colorado, Oklahoma, Missouri and Arkansas), 9 (Texas, Louisiana and New Mexico), 10 (Washington, Oregon, Idaho, California, Nevada and Arizona), and 11 (Canadian Lines). The decrease in coal car surplus is in groups 3 (Ohio, Indiana, Michigan and Western Pennsylvania), 4 (the Virginias and Carolinas), 5 (Kentucky, Tennessee, Mississippi, Alabama,

Georgia and Florida), 6 (Iowa, Illinois, Wisconsin and Minnesota), 7, 10 and 11 (as above). The decrease in miscellaneous car surplus is in groups 1 (New England Lines), 4, 9 and 10 (as above). The increase in box car surplus is in groups 2, 3, 6, 8 and 11 (as above).

The total shortage on June 30, 1913, was 7,036 cars; on June 14, 1913, 7,199 cars; and on July 4, 1912, 6,707 cars. Compared with the preceding period: there is a decrease in the total shortage of 163 cars of which 843 is in box, 163 in flat, and an increase of 788 in coal, and 55 in miscellaneous car shortage. The decrease in box car shortage is in groups 5, 6, 7 and 11 (as above). The decrease in flat car shortage is in groups 1, 4, 8, 10 and 11 (as above). The increase in coal car shortage is in groups 1, 2, 3, 6 and 10 (as above). The increase in miscellaneous car shortage is in groups 3, 8, 10 and 11 (as above).

Compared with the same date of 1912: there is an increase in the total surplus of 9 cars of which 5,023 is in box, 46 in flat, and

a decrease of 2,187 in coal and 2,873 in miscellaneous car surplus. There is an increase in the total shortage of 329 cars of which 1,785 is in coal, 29 in miscellaneous and a decrease of 1,099 in box and 386 in flat car shortage.

The accompanying table gives car surplus and shortage figures by groups for the last period covered in the report and the diagram shows total bi-weekly surpluses and shortages from 1907 to 1913:

**Good Wagon Roads Pay for Themselves.**

This is the title of a statement issued by the Department of Agriculture showing where land values have increased in value after the improvement of a country road. The statement is based on information gathered by the Office of Public Roads. Among the illustrations cited are the following:

In Lee County, Virginia, a farmer owned 100 acres between

CAR SURPLUSES AND SHORTAGES.

Date.	No. of roads.	Surpluses				Shortages					
		Box.	Flat. and hopper.	Coal, gondola and hopper.	Other kinds.	Total.	Box.	Flat.	Coal, gondola and hopper.	Other kinds.	Total.
Group *1.—June 30, 1913.....	7	491	668	189	56	1,404	1,302	110	334	0	746
" 2.—" 30, 1913.....	35	1,097	20	1,003	660	2,780	0	0	692	0	692
" 3.—" 30, 1913.....	32	4,367	193	1,422	2,369	8,351	81	149	302	64	596
" 4.—" 30, 1913.....	13	3,109	244	878	498	4,729	339	509	1,111	30	1,989
" 5.—" 30, 1913.....	28	1,291	0	300	908	2,499	59	410	150	0	619
" 6.—" 30, 1913.....	33	5,159	207	1,771	3,827	10,964	276	52	161	36	525
" 7.—" 30, 1913.....	5	289	19	118	409	835	63	0	0	0	63
" 8.—" 30, 1913.....	21	7,548	342	2,423	3,858	14,171	377	18	61	44	500
" 9.—" 30, 1913.....	15	1,004	297	342	595	2,238	4	0	4	25	33
" 10.—" 30, 1913.....	21	6,563	970	2,609	7,056	17,198	72	30	6	89	197
" 11.—" 30, 1913.....	7	3,767	124	0	1,680	5,571	789	192	0	95	1,076
<b>Total .....</b>	<b>217</b>	<b>34,685</b>	<b>3,084</b>	<b>11,055</b>	<b>21,916</b>	<b>70,740</b>	<b>2,362</b>	<b>1,470</b>	<b>2,821</b>	<b>383</b>	<b>7,036</b>

\*Group 1 is composed of New England lines; Group 2—New York, New Jersey, Delaware, Maryland and Eastern Pennsylvania lines; Group 3—Ohio, Indiana, Michigan and Western Pennsylvania lines; Group 4—West Virginia, Virginia, North and South Carolina lines; Group 5—Kentucky, Tennessee, Mississippi, Alabama, Georgia and Florida lines; Group 6—Iowa, Illinois, Wisconsin and Minnesota lines; Group 7—Montana, Wyoming, Nebraska, North Dakota and South Dakota lines; Group 8—Kansas, Colorado, Missouri, Arkansas and Oklahoma lines; Group 9—Texas, Louisiana and New Mexico lines; Group 10—Washington, Oregon, Idaho, California, Nevada and Arizona lines; Group 11—Canadian lines.

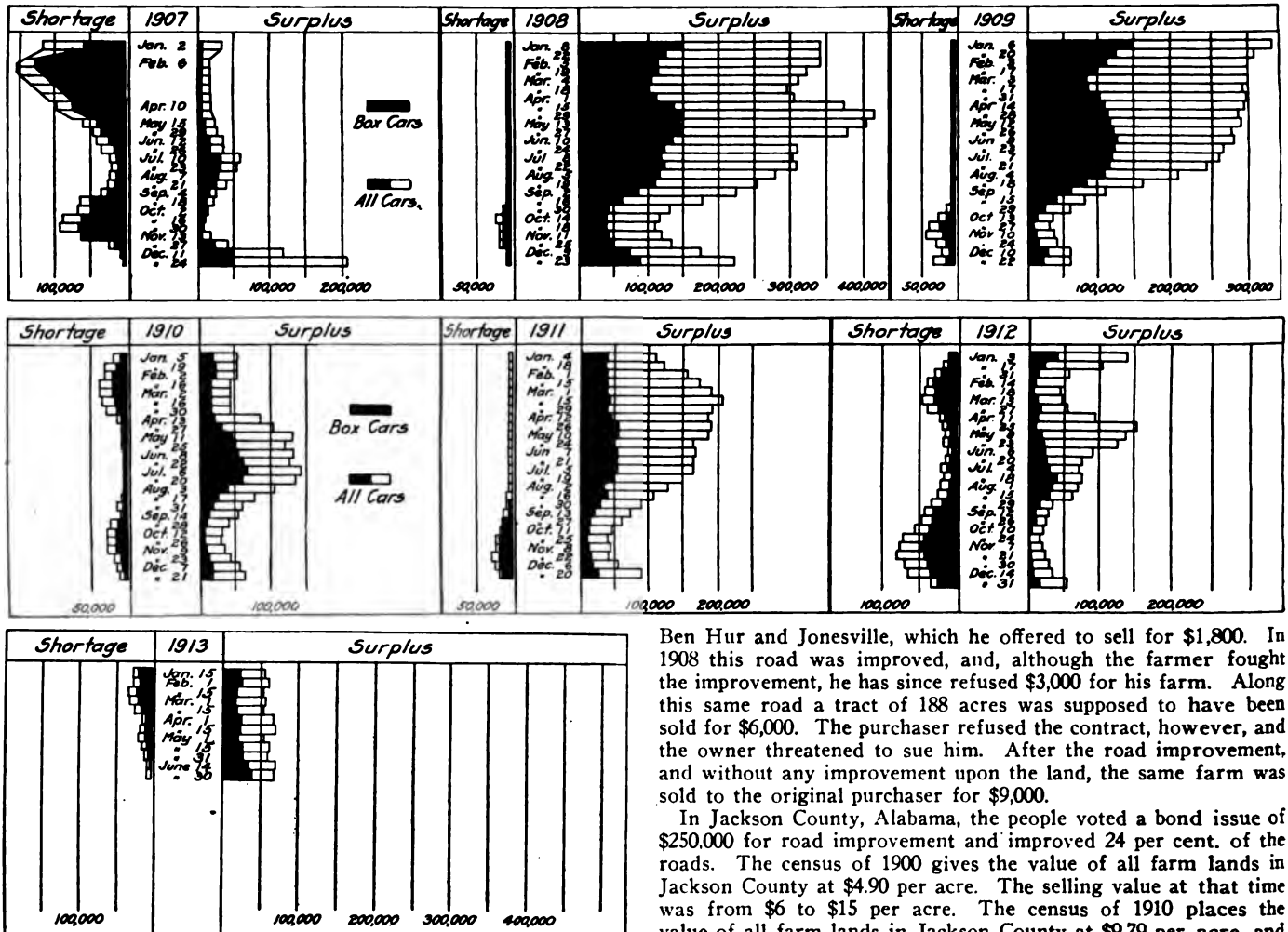

Car Surpluses and Shortages, 1907 to 1913.

Ben Hur and Jonesville, which he offered to sell for \$1,800. In 1908 this road was improved, and, although the farmer fought the improvement, he has since refused \$3,000 for his farm. Along this same road a tract of 188 acres was supposed to have been sold for \$6,000. The purchaser refused the contract, however, and the owner threatened to sue him. After the road improvement, and without any improvement upon the land, the same farm was sold to the original purchaser for \$9,000.

In Jackson County, Alabama, the people voted a bond issue of \$250,000 for road improvement and improved 24 per cent. of the roads. The census of 1900 gives the value of all farm lands in Jackson County at \$4.90 per acre. The selling value at that time was from \$6 to \$15 per acre. The census of 1910 places the value of all farm lands in Jackson County at \$9.79 per acre, and the selling price is now from \$15 to \$25 per acre. Actual figures

of increased value following road improvement in this county are shown. A farm is a plant for the business of farming, and any reduction in its profits through unnecessarily heavy costs for hauling on bad roads naturally reduces the value of the property. The automobile has begun to be an important factor in increasing rural values where good roads are introduced. Immigration is particularly marked where road conditions are favorable.

**St. Louis Business Men's League Favors Rate Advance.**

The St. Louis Business Men's League, composed of 2,500 leading business men of that city, has adopted a resolution favoring the proposed advance in freight rates, as follows:

"Whereas, certain railroads in what is known as Official Classification territory have in effect requested from the Interstate Commerce Commission permission to advance their freight rates uniformly 5 per cent., and whereas, we believe that the railroads are not now receiving sufficient revenue to enable them to perform under present conditions service adequate to the needs of the commerce of the country—

"Therefore, be it resolved, That this league hereby request the commission to grant to these railroads as promptly as circumstances will permit, permission to advance freight rates in the uniform manner set forth in their recent petition upon presentation of such figures as will prove the necessity of such increases."

**Car Location.**

The accompanying table, which is taken from bulletin No. 7-A of the American Railway Association, gives a summary of freight car location by groups on June 14, 1913.

	CAR LOCATION ON JUNE 14, 1913.												Grand Total
	New England	N.Y., N.J., Del., Md., Pa.	Ohio, Mich., Pa.	Ind., W. Va., No. & So. Carolina.	Ky., Tenn., Miss., Ala., Ga., Fla.	Iowa, Ill., Wis., Minn.	Mont., Wyo., Neb., Dakotas.	Kans., Colo., Okla., Mo., Ark.	Texas, La., New Mexico.	Oregon, Idaho, Nev., Cal., Ariz.	Canadian Lines.		
Total Cars Owned	87,866	660,413	274,954	202,875	172,988	465,728	17,177	151,571	33,354	131,219	135,977	2,334,122	
Home Cars on Home Roads	42,437	380,695	102,223	108,986	86,755	315,588	5,600	81,722	15,288	75,952	92,676	1,307,922	
Home Cars on Foreign Roads	45,429	279,718	172,731	93,889	86,233	150,140	11,577	69,849	18,066	55,267	43,301	1,026,200	
Foreign Cars on Home Roads	50,097	291,855	218,491	79,482	72,330	167,766	8,130	63,393	21,407	50,489	44,668	1,068,108	
Total Cars on Line	92,534	672,550	320,714	188,468	159,085	483,354	13,730	145,115	36,695	126,441	137,344	2,376,030	
Excess or Deficiency	4,668	12,137	45,760	*14,407	*13,903	17,626	*3,447	*6,456	3,341	*4,778	1,367	41,908	
Surplus	1,404	2,780	8,351	4,729	2,499	10,964	835	14,171	2,238	17,198	5,571	70,740	
Shortage	746	692	596	1,989	619	525	63	500	33	197	1,076	7,036	
Shop Cars—													
Home Cars in Home Shops	4,555	34,283	16,902	12,238	14,790	22,024	817	10,763	2,112	5,635	4,757	128,876	
Foreign Cars in Home Shops	1,103	8,352	7,577	2,437	2,550	3,997	503	2,065	1,008	2,554	725	32,871	
Total Cars in Shop	5,658	42,635	24,479	14,675	17,340	26,021	1,320	12,828	3,120	8,189	5,482	161,747	
Per Cent. to Total Cars Owned—													
Home Cars on Home Roads	48.30	57.65	37.18	53.72	50.15	67.76	32.60	53.92	45.84	57.88	68.16	56.04	
Total Cars on Line	102.36	101.84	116.74	92.91	92.41	103.78	79.93	95.74	110.02	96.36	101.00	101.80	
Home Cars in Home Shops	5.18	5.19	6.15	6.03	8.55	5.06	4.75	7.10	6.33	4.29	3.50	5.52	
Foreign Cars in Home Shops	.93	1.27	2.75	1.20	1.47	.92	2.93	1.36	3.02	1.95	.53	1.41	
Total Cars in Shops	6.11	6.46	8.90	7.23	10.02	5.98	7.68	8.46	9.35	6.24	4.03	6.93	

\*Denotes deficiency.

**INTERSTATE COMMERCE COMMISSION.**

The commission has suspended from July 15 until September 12, the schedule in the tariff of the Wheeling & Lake Erie, which would advance from 1½ to 2½ cents per 100 lbs. the charge applicable to shipments of structural and bridge iron and steel stopped in transit for fabrication at fabricating points located on the above named roads. Tariffs of other carriers in Central Freight Association territory which proposed to effect a like advance in the transit charge in question were suspended by an order previously entered in the same docket.

Special Examiner Gerry held a hearing at Chicago on July 11, on the application of the Chicago River & Indiana for the suspension of tariffs filed by the Wabash; New York, Chicago & St. Louis; Grand Trunk and Erie railways, cancelling the absorption of the Chicago River & Indiana terminal charge for car float service on the Chicago river. When the absorption tariffs were filed the rate of the Chicago River & Indiana was one cent per 100 lbs. In January, 1912, this rate was advanced to three cents per 100 lbs., and the railroads declined to absorb the charge any longer. On behalf of the Chicago River

& Indiana it was stated that the company could not continue in business at the low rate, which did not even defray the cost of unloading.

**Coal Rate Reduced.**

*Board of Railroad Commissioners of the State of Montana v. Denver & Rio Grande et al. Opinion by the commission:*

The rate of \$5 per ton charged by defendants prior to December 27, 1911, for transportation of coal in carloads from Sunnyside, Utah, to Helena, Mont., not shown to have been unreasonable. Increase of 10 cents per ton in the rate as of the date mentioned found not justified by defendants, and therefore unreasonable. The defendants were ordered not to charge more than \$5 per ton in future. (27 I. C. C., 522.)

**Salt Rates from Wisconsin to Iowa.**

*In re investigation and suspension of salt rates from Wisconsin to Iowa, etc. Opinion by Commissioner Meyer:*

The tariff provision by which the respondent would be exempted from participation in joint rates on salt in carloads from Milwaukee and certain other points in Wisconsin to points in Iowa, etc., is not approved. The respondent is required to maintain the present rates as maxima for two years. (27 I. C. C., 526.)

**Barrel Stave Rates.**

*Holland Blow Stave Company v. Atlantic Coast Line et al. Opinion by Commissioner Meyer:*

In view of additional facts presented at the rehearing of this case, the order of the commission in the former proceeding

(24 I. C. C., 81, mentioned in the *Railway Age Gazette* of June 28, 1912, page 1622) establishing adjustment of rates on barrel staves and heading from Decatur, Ala., to western markets not to exceed 4 cents over the rates from Memphis, was vacated. (27 I. C. C., 488.)

**Hay Rates Increased.**

*In re investigation and suspension of Ohio river hay rates. Opinion by Commissioner Harlan:*

The commission decided that the proposed rates on hay from points in the northwest to the Ohio River crossings had been justified. The order of suspension was vacated. No undue discrimination was found in the proposed rates in favor of the Michigan hay-producing territory as against shipping points in Wisconsin and Minnesota. (27 I. C. C., 465.)

**Local Commercial Telephone Service in Pittsburgh, Pa.**

*Opinion by Commissioner Clements:*

Upon protest of alleged undue discrimination against new subscribers to the local telephone service of Pittsburgh, Pa., because, instead of the old form contract under which unlimited

service is given at a flat rate per annum, they are offered only the various forms of limited-service contract which provide for a certain number of calls at a stated sum per annum, with additional calls at so much per call. The commission decided that in view of the fact that no charge is made or call recorded against either class of subscribers by respondent company for the local call used in connecting with the interstate line, and that therefore there is no discrimination with respect to interstate transmission, this is a controversy over which, upon the facts of this case, this commission has no jurisdiction. Proceeding discontinued. (27 I. C. C., 622.)

#### Joint Rates with the Washington Western.

*In re investigation and suspension of advances in rates by carriers for the transportation of lumber, shingles, and other articles from points located on the Washington Western Railway to points in Minnesota, Illinois, Indiana, and other states. Opinion by Commissioner Harlan:*

The cancellation of joint rates with a tap line incorporated by the proprietary lumber company for the purpose through that means of getting allowances out of the rates was sustained on a finding that with respect to the lumber of the proprietary company the tap line is a plant facility.

In a lumber-producing territory, where the rates apply in all other instances only from the trunk line junctions with tap lines, it does not necessarily follow that the protestant lumber company would be entitled to the group rates even if its tap line on the record was shown to be a full-fledged common carrier. The order of suspension was vacated. (27 I. C. C., 630.)

#### Grain Rates from Toledo.

*Toledo Produce Exchange v. Ann Arbor et al. Opinion by Commissioner Meyer:*

The Toledo Produce Exchange complains against the restrictions placed upon the forwarding of grain and grain products after transit at Toledo, Ohio, and asks for the establishment of reshipping rates, ex-lake rates, and export rates on grain and grain products on the usual basis of 78 per cent. of the corresponding Chicago-New York rates. The commission held that joint through rates with transit at Toledo should be established to cover the movement of grain and grain products by all reasonably direct routes to points in the east.

Domestic and export rates on ex-lake grain forwarded from Toledo to New York should be established in the relation of 78 from Toledo to 60 from Buffalo. The customary differentials to other destinations should be observed.

Export rates on grain and flour from Toledo to New York should be as 78 is to 60 for the export rates on grain and flour from Buffalo with the customary differentials to other north Atlantic ports. (27 I. C. C., 536.)

#### Coal Rates Discriminatory.

*Consolidated Fuel Company et al. v. Atchison, Topeka & Santa Fe et al. Opinion by Commissioner Harlan:*

The Denver & Rio Grande in competing commercially in interstate coal markets, through the operations of a coal company owned by it, not only violates the commodities clause of the act, but is guilty of an unjust rate discrimination against the complainants, in that the group rates apply only from its junction with the industrial lines of the complainants, while they are applicable directly from its own mines on its own branch lines, the latter being operated under general conditions substantially similar to those surrounding the operation of the industrial lines of the complainants.

Without entering an order, several forms of relief which the complainants may have under the circumstances of the case are indicated in the report, and the tariffs in question are required promptly to be adjusted in one form or other, the rate situation as readjusted to be maintained so long as the Denver & Rio Grande competes commercially in interstate markets with the complainants. (27 I. C. C., 554.)

#### Milk Rates Reduced.

*Dixie Dairymen's Association v. Yazoo & Mississippi Valley. Opinion by Commissioner Harlan:*

The complainant contends that the rate charged by the defendant for the transportation of milk in cans on passenger trains from points in Mississippi to New Orleans are excessive and un-

reasonable; that the rates are unduly discriminatory in that the charge on milk is the same as on cream, a more valuable commodity; and that the fourth section of the act is violated in existing schedule of rates. The commission found that no violation of the fourth section was shown in the record. The commission decided that the present rates on milk are unreasonable and prescribed reasonable rates for the future. The commission also urged the defendant to make a distinction between cream and milk, by charging somewhat higher rates on the former commodity than on the latter. (27 I. C. C., 618.)

#### Lumber Rates from Memphis and Other Points to New Orleans.

*In re investigation and suspension of advances in rates by carriers for the transportation of hard-wood and other kinds of lumber and articles manufactured therefrom from points in Arkansas, Louisiana, and other points to Memphis, Tenn., St. Louis, Mo., and other points of destination.*

The commission decided that the proposed advanced rate on lumber, staves, and heading from Memphis, Tenn., to New Orleans, La., was reasonable.

Those parts of the fourth-section application of the Illinois Central and the Yazoo & Mississippi Valley asking permission to charge lower rates on lumber, staves, and heading from Memphis to New Orleans than from intermediate points were denied.

The proposed advanced rates on lumber, staves, and heading from points on the Illinois Central and the Yazoo & Mississippi Valley between Memphis and the line of the Southern Railway in Mississippi were not justified in so far as they exceed 11 cents per 100 lbs.

The proposed advanced rates on these products from points on the Illinois Central and the Yazoo & Mississippi Valley south of the Southern Railway in Mississippi were not justified.

The proposed advanced rates on gum lumber from points on the Southern Railway in Mississippi were justified.

The proposed advances on gum lumber and staves from Helena and Arkansas City, Ark., were justified.

The proposed advanced rate from Alexandria, La., found not to have been justified in so far as it exceeds 8 cents per 100 lbs. (27 I. C. C., 471.)

#### Lumber Rates to Memphis, Tenn.

*Memphis Freight Bureau v. Illinois Central et al. Opinion by Commissioner Marble:*

Present rates on pine lumber to Memphis, Tenn., from Jackson, Miss., and points on the Illinois Central north thereof, found to be unreasonable in so far as they exceed 10 cents per 100 lbs.

Present rates on lumber, staves, and headings to Memphis, Tenn., from points south of the Alabama & Vicksburg Railway and east of the Mississippi river on the lines of respondents, except that of the New Orleans, Mobile & Chicago, were found to be unreasonable in so far as they exceed 11 cents for a haul over one line, or 12 cents for a haul over two or more lines.

Maintenance by the New Orleans, Mobile & Chicago of rates for the transportation of lumber and headings from points on its line to Memphis, Tenn., higher than the rates contemporaneously maintained by it for the transportation of staves between the same points was found to be unjustly discriminatory.

The proposed advances in the rates on lumber from points on the Illinois Central and the Yazoo & Mississippi Valley in Mississippi and Louisiana to Memphis, Tenn., were found not to have been justified in so far as they make rates in excess of those found reasonable.

The commission made no finding as to the rates to Memphis, Tenn., from Vicksburg and Jackson, Miss., and points north thereof, on lumber other than pine. (27 I. C. C., 507.)

#### Sioux City Not Discriminated Against.

*Sioux Terminal Elevator Company et al. v. Chicago, Milwaukee & St. Paul et al. Opinion by Commissioner Clements:*

The findings in original report that defendants are not subjecting Sioux City, its traffic and shippers, to undue prejudice and disadvantage because they refuse to establish and maintain a basis of proportional rates on grain from Sioux City to Chicago and other markets in lieu of the present basis of joint through rates from points of origin to final destination with transit privileges at Sioux City, while, contemporaneously main-

taining such a basis of proportional rates from Omaha and Kansas City to the same ultimate markets, adhered to.

The difference in competitive conditions affecting the traffic in grain through Sioux City from the competitive conditions affecting similar traffic through Omaha and Kansas City was further discussed. In considering the lawfulness of rate adjustments the commission cannot treat all carriers within its jurisdiction as if they were embraced in one united system, or deal with complaints against existing rates as matters alone of general policy in which it may exercise a wide discretion in the equalization of all disadvantages between markets, but it must give full recognition to the separate organizations and obligations of individual carriers and to the effect of substantial differences in circumstances and conditions in the determination of whether the granting or withholding of a given rate or practice is unduly preferential or prejudicial against the complaining locality. (27 I. C. C., 457.)

#### Wheat Rates from Chicago and Minneapolis.

*Board of Trade of the City of Chicago v. Chicago & Alton et al.*

The proportional rate of 10 cents per 100 lbs. on wheat from Minneapolis to Chicago was found to be neither unreasonable nor unjustly discriminatory.

An arrangement under which Minneapolis pays 25 cents on flour to the east and to central freight association territory, while Chicago must pay 10 cents more than Minneapolis for its wheat and 16.7 cents east on its flour, a total of 26.7 cents, is unjustly discriminatory and the discrimination should be removed.

Milling in transit is established to give to the miller the benefit of the through grain rate which he could not otherwise obtain. If rival mills may procure their wheat from the same producing points at the same through rate, the principle is satisfied, and one miller should not expect to enter another milling point and reship the raw material there found to his own mill on an equality with the miller by whom the raw material has been accumulated. And so held with respect to an adjustment of rates under which Chicago can ship direct from points of production at rates as low or lower than Minneapolis, but can not draw from Minneapolis certain wheat there accumulated and reship to Chicago on the same basis as the Minneapolis miller.

Chicago's failure to attract wheat in the same volume as Minneapolis is a disadvantage due to commercial rather than transportation conditions and is not chargeable to the defendants.

Wheat, on the one hand, and barley, rye, oats, and other coarse grains, on the other, do not constitute such "like traffic" that a different charge for their contemporaneous transportation is violative of section 2. (27 I. C. C., 530.)

#### Commodity and Class Rates from Pittsburgh.

*Koehler Produce Company et al v. Pennsylvania Railroad, et al. Opinion by Commissioner Clements:*

In this case the rates on general produce from Pittsburgh, Pa., to stations west and south of that city on the lines of the Baltimore & Ohio and the Pennsylvania Lines West, are attacked as unreasonable. The destinations in issue are within a radius of about 80 miles from Pittsburgh. Prior to 1909 the defendants published special commodity rates on produce to these destinations, applicable on either straight or mixed carloads. In 1909 both the Baltimore & Ohio and the Pennsylvania Lines West cancelled these rates, thereby restoring the class rate basis applicable on the individual commodities constituting the mixed carloads. The Pennsylvania Railroad and the Baltimore & Ohio now publish commodity rates to stations on their lines east of Pittsburgh upon the same relative basis as were the commodity rates to the points west of Pittsburgh, which were cancelled. The complainant contends that under this arrangement the stations west and south of Pittsburgh are discriminated against in favor of those east. The commission decided that the class rates from Pittsburgh to stations west and south of that city are not unreasonable in themselves, but are prejudicial against the complainant in favor of shippers under the commodity rates to points east of Pittsburgh. No order was entered, but the defendants will be expected to remove this discrimination. Reparation was asked, but was denied. (27 I. C. C., 635.)

#### STATE COMMISSIONS.

The Missouri Public Utilities Commission has denied the application of the Missouri River & Bonne Terre for permission to retain the three-cent fare, pending an investigation, and the road has put the two-cent rate into effect.

The California State Railroad Commission, in a recent decision, holds that it possesses the authority to regulate the rates of transportation on steamships plying over regular routes from one port to another within the state, even though the vessels traverse the high seas.

The newly established Public Service Commission of Massachusetts, succeeding to the duties of the Railroad Commission, has been organized by the choice of F. J. MacLeod as chairman. The office of the commission is at 20 Beacon street, Boston, and the secretary is Charles E. Mann.

The Railroad Commission of Alabama recently issued an order requiring the Alabama, Tennessee & Northern to reduce passenger fares to the basis of 3 cents a mile, the order to go into effect July 15; but, on application of the road for a rehearing, the order has been suspended for thirty days.

The nominations of Messrs. Chase and Leffingwell, as members of the New York State Public Service Commission, Second district, announced last week, have not as yet been confirmed by the Senate. Chairman Frank W. Stevens resigned his place on the commission in May and on July 1, Commissioner M. S. Decker was named chairman. The secretary of this commission is Frank H. Mott.

The Public Utilities Commission of Connecticut has issued a report on the rear collision which occurred at Stamford, June 12, and lays the responsibility on the engineman of the second section. The report embraces conclusions substantially the same as those of the Interstate Commerce Commission, noticed elsewhere, except that there is a further recommendation that enginemen should be frequently examined to determine their fitness.

The Public Service Commissions of New York, each in its own district, now have authority over stage routes and omnibus lines, under certain conditions, such conveyances being declared common carriers by a law, chapter 495, passed by the legislature on May 14. The law applies to stages and omnibuses running wholly or partly on a "state route" highway; or on any highway built wholly or partly at the expense of the state, or any highway, avenue, or public place in a city of the first class having 750,000 population, or less. These carriers must secure a certificate of convenience and necessity, as is required in the case of other common carriers. If the road has been built partly at the expense of a railroad or street railroad corporation the commission may require the stage line to contribute towards its maintenance.

#### COURT NEWS.

The Appellate division of the Supreme Court of New York, in a decision handed down July 10, sustains the order of the Public Service Commission, requiring the Brooklyn Rapid Transit Company to equip its surface street cars with power brakes and geared hand brakes. It is estimated that the cost of the changes required by the order will be \$500,000, and the company has been resisting the order in the courts for about two years.

The attorney general of Texas has filed an amendment to the suit recently filed in the district court at Austin, which attacked the recent consolidation of the Texas lines of the Missouri, Kansas & Texas system as a violation of the anti-trust law. The amendment makes the Missouri, Kansas & Texas Railway, the Kansas corporation, a party to the suit, and seeks to recover penalties for alleged violations of the Texas anti-trust statutes. It is alleged that the Missouri, Kansas & Texas, the Missouri, Kansas & Texas of Texas, the Dallas, Cleburne & Southwestern, the Denison, Bonham & New Orleans, and the Texas Central have each violated the statute for about 1,130 days; that the Beaumont & Great Northern has violated it for about 304 days, and other defendant roads for about 659 days each.

REVENUES AND EXPENSES OF RAILWAYS.

MONTH OF MAY, 1913.

Table with columns: Name of road, Average mileage operated during period, Operating revenues (Freight, Passenger, inc. misc. structures, equipment), Maintenance of Way and Traffic, Trans- portation, General, Total, Net operating revenue (or deficit), Outside operations net, Taxes, Operating income (or loss), Increase (or decr.) comp. with last year.

ELEVEN MONTHS OF FISCAL YEAR, 1913.

Table with columns: Name of road, Average mileage operated during period, Operating revenues (Freight, Passenger, inc. misc. structures, equipment), Maintenance of Way and Traffic, Trans- portation, General, Total, Net operating revenue (or deficit), Outside operations net, Taxes, Operating income (or loss), Increase (or decr.) comp. with last year.

REVENUES AND EXPENSES OF RAILWAYS.

SEVEN MONTHS OF FISCAL YEAR, 1913—(CONTINUED).

Name of road.	Average mileage operated during period.	Operating revenues			Maintenance			Operating expenses			Net operating revenue (or deficit).	Outside operations net.	Taxes.	Operating income (or loss).	Increase (or decr.) comp. with last year.
		Freight.	Passenger.	Total.	Inc. misc. structures.	Way and equipment.	Traffic.	Trans- portation.	General.	Total.					
New Orleans & North Eastern.....	196	\$2,571,676	\$592,578	\$3,424,066	\$363,200	\$662,655	\$109,292	\$1,328,904	\$134,361	\$2,598,412	\$852,654	-\$3,414	\$135,381	\$686,859	-\$132,191
New Orleans Great Northern.....	543	1,883,211	330,471	1,639,528	156,460	241,667	27,482	486,568	72,929	988,658	650,890	-640	24,386	625,864	162,571
New Orleans Mobile & Chicago.....	287	1,862,732	325,233	2,323,978	359,562	241,697	39,877	895,847	90,533	1,627,311	696,467	-987	66,049	631,431	98,134
New Orleans, Texas & Mexico.....	286	1,151,840	181,204	1,436,043	143,025	269,712	37,762	643,682	71,147	1,165,328	271,075	373,677	57,302	250,433	108,974
New York Central & Hudson River.....	3,750	62,840,815	30,975,758	104,640,612	20,699,953	19,482,986	2,035,017	38,223,638	2,559,977	76,397,974	28,242,638	373,677	5,730,852	22,849,823	2,849,823
New York, Chicago & St. Louis.....	564	9,749,274	1,397,922	11,529,867	1,214,852	1,592,168	475,806	4,966,119	192,714	8,513,659	3,016,208	-21,409	361,583	2,633,216	-33,703
New York, New Haven & Hartford.....	2,091	31,784,745	25,413,732	63,197,732	7,298,959	8,162,084	375,358	25,589,039	1,797,493	43,842,933	19,354,819	674,710	3,518,000	16,511,529	-1,870,594
New York, Ontario & Western.....	566	6,696,811	1,527,189	8,638,337	1,092,291	1,404,247	120,930	1,853,383	179,695	5,982,566	2,635,771	-21,770	204,166	4,239,835	893,277
New York, Philadelphia & Norfolk.....	112	2,682,892	453,559	3,387,818	275,646	607,736	83,906	1,493,072	142,038	2,564,948	823,330	77,400	74,000	749,330	7,336
New York, Susquehanna & Western.....	154	1,861,568	523,603	2,700,198	283,822	329,701	21,886	1,131,809	44,995	1,822,183	878,015	-26,359	164,777	686,879	-101,641
Norfolk & Western.....	2,034	34,388,548	4,299,975	39,997,032	5,050,893	7,899,420	630,619	12,020,890	730,300	26,022,130	13,974,902	-22,811	1,330,000	12,622,091	1,042,749
Norfolk Southern.....	562	2,090,293	732,030	3,070,562	366,699	403,760	53,753	973,269	159,498	1,956,979	1,113,583	-10,945	79,908	1,027,730	-52,481
Northern Central.....	472	9,172,224	2,267,043	12,228,021	1,523,816	2,535,265	177,182	5,859,782	294,749	10,930,794	4,937,227	5,877	149,139	3,855,961	35,481
Northern Pacific.....	6,314	48,397,516	14,232,748	66,651,916	9,340,860	7,696,012	1,193,456	21,720,576	955,490	40,906,394	25,745,522	282,830	3,658,331	22,370,021	2,015,139
Northwestern Pacific.....	401	1,304,690	1,800,586	3,336,916	481,269	460,729	41,025	1,240,742	142,023	2,365,788	991,128	-2,646	139,872	1,300,949	130,949
Oahu Ry. & Land Co.....	101	735,189	253,580	1,061,142	95,356	77,747	6,632	238,461	50,791	468,967	592,175	-2,646	68,516	521,013	-19,223
Oregon Short Line.....	1,942	14,590,998	4,452,724	20,311,215	2,271,276	2,349,677	340,228	5,150,960	484,281	10,600,432	9,710,793	893	1,329,028	8,382,658	-15,842
Oregon-Washington R. R. & Nav. Co.....	1,914	10,955,120	4,640,112	16,712,670	2,293,803	1,827,378	511,497	6,720,208	545,573	11,257,559	5,455,111	-53,125	1,068,115	4,333,871	333,829
Pecos & Northern Texas.....	482	1,738,642	455,338	2,340,398	280,247	463,573	40,791	756,693	72,135	1,115,349	725,049	57,884	667,165	220,931	220,931
Pennsylvania Co.....	1,751	45,971,239	8,936,383	60,418,574	9,983,235	14,266,174	926,176	21,647,321	1,132,180	44,758,936	15,659,638	-47,429	2,688,895	12,923,314	1,245,826
Pennsylvania Railroad.....	4,025	121,824,376	33,441,905	166,270,968	21,667,349	35,329,455	2,172,554	59,744,211	3,903,376	122,816,945	43,454,023	-1,260,962	6,696,949	35,496,112	1,563,967
Peoria & Eastern.....	352	2,415,559	655,915	3,276,775	482,569	649,084	51,379	1,284,264	63,706	2,531,002	745,773	120,748	120,748	625,025	2,682
Phila. Matquits.....	2,330	11,080,260	3,685,524	16,096,987	2,548,035	2,713,358	367,745	6,602,577	387,745	12,633,279	3,463,708	49,520	520,478	2,990,730	685,138
Philadelphia & Reading.....	1,015	37,792,093	6,437,593	46,534,884	4,200,182	7,799,991	331,366	14,917,792	672,650	28,015,981	18,518,903	371,935	949,449	17,941,389	3,937,233
Philadelphia, Baltimore & Washington.....	713	9,562,796	7,793,704	19,330,402	3,207,682	3,527,462	454,146	8,105,663	488,613	15,663,566	3,656,836	.....	590,731	3,066,105	-379,111
Pittsburgh & Lake Erie.....	223	16,065,913	1,573,492	18,305,266	1,774,302	2,745,106	149,305	4,095,786	295,328	9,059,827	9,245,439	-4,611	424,789	8,816,039	231,870
Pittsburgh, Cincinnati, Chis. & St. Louis.....	1,472	28,975,169	7,627,246	40,861,837	6,958,149	8,189,606	774,498	15,222,247	801,778	31,846,827	9,015,559	-8,628	1,545,300	7,461,631	-1,366,602
Pittsburgh, Shawmut & Northern.....	279	1,708,666	102,213	1,840,793	313,429	406,337	12,860	590,511	45,942	1,169,079	471,714	75,405	17,522	451,192	25,268
Port Reading.....	21	1,444,228	1,479,975	3,198	392,454	313,333	392,454	313,333	1,579	1,513,956	964,019	.....	88,000	951,424	209,421
Richmond, Fredericksburg & Potomac.....	88	1,430,478	946,519	2,709,393	283,359	296,340	33,113	957,057	75,571	1,645,220	1,064,173	-2,714	8,303	1,053,156	239,783
Rutland.....	468	1,845,936	1,102,168	3,383,526	415,188	690,373	90,717	1,358,014	74,648	2,628,940	754,586	165,196	165,196	589,390	-92,747
St. Joseph & Grand Island.....	319	946,641	354,701	1,432,040	324,952	219,791	4,320,940	634,662	62,081	1,304,195	127,845	447	60,519	23,014	-23,014
St. Louis, Brownsville & Mexico.....	518	1,701,133	843,961	2,724,379	420,907	482,240	52,448	1,271,556	104,198	2,131,410	592,969	.....	65,947	530,022	-93,884
St. Louis, Mont. Mountain & Southern.....	3,365	23,456,968	5,949,349	31,656,557	5,021,991	4,578,480	627,465	9,896,727	788,568	20,913,231	10,743,426	-49,496	1,063,245	9,630,685	1,445,032
St. Louis Merchants' Bridge Terminal.....	9	4,076	1,921,758	339,336	339,336	110,985	7,660	990,532	66,833	1,515,346	406,412	.....	.....	342,594	95,381
St. Louis, San Francisco & Texas.....	244	1,000,657	320,566	1,409,111	246,258	175,472	28,167	634,349	61,244	1,145,540	263,571	12,113	12,113	321,458	74,208
St. Louis Southwestern.....	906	6,143,031	1,388,430	7,966,836	849,919	1,132,922	322,210	1,889,453	286,344	4,890,908	3,485,934	-9,886	300,010	3,176,034	578,646
St. Louis Southwestern of Texas.....	703	3,058,741	1,021,199	4,370,064	979,775	879,445	146,341	1,809,220	216,177	3,971,098	398,966	-1,995	119,848	277,123	-59,372
San Antonio & Aransas Pass.....	727	3,228,612	1,284,902	4,745,183	789,136	588,721	68,000	1,851,943	121,285	3,419,098	1,326,098	.....	127,000	1,190,098	141,229
San Pedro, Los Angeles & Salt Lake.....	1,135	5,785,206	2,850,200	9,296,922	1,582,383	1,582,383	343,458	3,039,828	209,376	6,226,730	3,070,192	-19,301	393,697	2,657,197	1,465,397
Seaboard.....	3,082	15,444,445	4,844,024	22,597,206	2,829,113	3,095,450	705,345	8,180,647	632,839	15,443,394	7,143,812	-24,192	879,000	6,240,620	885,338
Seaboard in Mississippi.....	281	611,337	332,235	1,024,356	305,703	103,190	27,323	469,191	45,505	950,912	73,444	.....	81,293	7,849	-115,643
Southern.....	7,037	41,748,446	16,705,781	63,382,393	8,478,798	10,557,286	1,910,102	21,735,560	1,837,853	44,514,599	18,667,794	78,241	2,279,562	16,666,473	306,079
Southern Kansas Ry. Co. of Texas.....	125	1,624,066	1,097,716	4,141,094	103,378	290,979	24,628	424,423	40,272	883,680	529,414	.....	23,842	505,572	220,413
Southern Pacific Co.....	6,329	51,821,772	29,279,575	87,374,341	9,388,534	12,038,140	1,893,779	24,501,460	2,369,685	50,191,598	37,182,743	1,504,561	4,036,044	34,651,260	2,810,239
Spokane, Portland & Seattle.....	556	2,988,402	1,513,908	4,882,556	597,479	432,410	83,575	1,196,713	140,319	2,450,496	2,432,060	-428	587,400	1,844,232	143,174
Tennessee Central.....	294	1,066,355	395,066	1,549,600	310,769	160,471	62,435	526,867	74,508	1,139,050	410,350	.....	46,911	363,630	127,326
Terminal R. R. Assn. of St. Louis.....	34	.....	3,143	2,753,023	418,431	201,875	10,174	1,037,839	70,603	1,738,982	1,014,101	109,167	298,721	898,943	197,945
Texas & Pacific.....	1,885	11,648,869	4,149,270	16,875,270	2,179,070	2,740,449	375,150	7,796,870	507,866	13,599,347	3,275,883	-17,463	506,256	2,667,764	-373,433
Toledo & Ohio Central.....	443	4,219,582	575,611	5,070,866	763,699	949,419	76,723	1,802,817	101,839	3,694,497	1,376,369	-8,340	235,819	1,132,210	98,384
Toledo, Peoria & Western.....	248	4,995,346	441,096	1,261,752	223,628	280,420	26,414	469,751	38,717	1,038,930	222,822	.....	58,400	164,422	121,130
Toledo, St. Louis & Western.....	451	3,407,366	320,729	3,965,191	490,844	510,354	144,012	1,387,647	98,698	2,631,555	1,333,636	.....	162,700	1,170,936	246,122
Trinity & Brazos Valley.....	463	2,071,661	520,760	2,699,748	502,316	380,865	115,113	1,285,506	133,272	2,417,472	283,376	.....	43,513	238,813	-3,161
Union & Delaware.....	129	644,669	333,622	1,028,158	12										



## Railway Officers.

### Executive, Financial and Legal Officers.

Henry J. Horn, vice-president of the Boston & Maine at Boston, Mass., has resigned, effective August 1.

E. N. Brown, president of the National Railways of Mexico, at City of Mexico, Mexico, has resigned, and his resignation has been accepted.

T. D. Heed, assistant secretary and assistant treasurer of the Chicago & Eastern Illinois at New York, has been appointed assistant treasurer for the receivers, with office at New York City.

J. F. Meyer, assistant general manager of the Oregon-Washington Railroad & Navigation Company, has been appointed assistant treasurer, with office at Portland, Ore., succeeding R. Lea Barnes, resigned; effective July 1.

D. C. Douglass, assistant to vice-president and general manager of the Maine Central at Portland, Me., has been appointed assistant to the president of the Maine Central, the Portland Terminal Company, the Sandy River & Rangeley Lakes, the Bridgton & Saco River, and the Ricker Hotel Company.

Edward T. Jeffery, president of the Western Pacific at New York, has been elected chairman of the board and B. F. Bush, president of the Missouri Pacific and the Denver & Rio Grande, at St. Louis, Mo., has been elected president also of the Western Pacific, succeeding Mr. Jeffery. E. L. Brown, vice-president of the Denver & Rio Grande, at Denver, Colo., has been elected vice-president also of the Western Pacific, succeeding Charles H. Schlacks, resigned. Mr. Brown's headquarters will be at San Francisco, Cal.

### Operating Officers.

C. A. Wright has been appointed terminal trainmaster of the Chicago & Alton at East St. Louis, Ill.

S. A. Morrison has been appointed assistant superintendent of the Wisconsin division of the Chicago & North Western, instead of superintendent as stated in our issue of June 27.

John E. Church, trainmaster of the Pere Marquette at Saginaw, Mich., has been appointed trainmaster of the Delaware, Lackawanna & Western, with headquarters at Port Morris, N. J.

R. Colclough, assistant to general superintendent of the Intercolonial Railway at Moncton, N. B., has been appointed superintendent of the Montreal and Ste. Flavie district, with office at Levis, Que., succeeding D. McDonald, transferred.

Alfred Price, general superintendent of the Alberta division of the Canadian Pacific at Calgary, Alta., has been appointed assistant general manager, with office at Montreal, Que. The office of general superintendent of transportation has been abolished.

J. Q. Van Winkle, general manager of the Cleveland, Cincinnati, Chicago & St. Louis, at Cincinnati, O., has been appointed assistant to Vice-President J. J. Bernet, with office at Cincinnati. H. A. Worcester, assistant general manager, succeeds Mr. Van Winkle as general manager, also with office at Cincinnati; effective July 10.

Walter S. Williams, superintendent of the Minnesota division of the Illinois Central at Dubuque, Iowa, has been appointed superintendent of the St. Louis division, with offices at Carbondale, Ill., succeeding J. J. Gaven, granted leave of absence, and Lawrence A. Downs, superintendent of the Iowa division at Fort Dodge, Iowa, succeeds Mr. Williams as superintendent of the Minnesota division at Dubuque, Iowa.

J. A. Hillis, trainmaster of the Texas & Pacific at El Paso, Tex., has been appointed assistant superintendent of the Ft. Worth sub-division, including Baird yard, with headquarters at Baird, Tex., in place of E. Wilson, assigned to other duties. W. H. Homan, trainmaster at Big Spring, Tex., has been appointed assistant superintendent of the Baird, Big Spring and Toyah sub-divisions, with office at Big Spring. The office of assistant trainmaster at Ft. Worth, Tex., is abolished.

C. D. Baker, passenger trainmaster, electrified lines of the Long Island, at Brooklyn, N. Y., has been appointed to the new position of trainmaster, with office at Jamaica. The passenger trainmaster, electrified lines, passenger trainmaster, steam lines, and the freight trainmaster will report to the trainmaster. The positions of assistant trainmaster, day, and assistant trainmaster, night, have been abolished. C. H. Risley has been appointed passenger trainmaster, electrified lines, succeeding Mr. Baker. H. E. Lewis, chief train dispatcher, has been appointed passenger trainmaster, steam lines, succeeding W. L. Jarvis, assigned to other duties, and J. M. Magee succeeds Mr. Lewis.

J. O. Bell, whose appointment as superintendent of the Illinois division of the Chicago & Eastern Illinois, with headquarters at Salem, Ill., has already been announced in these columns, began railway work as a telegraph operator for the Pittsburgh, Ft. Wayne & Chicago at Delphos, Ohio. One year later he went to the Toledo, Peoria & St. Louis as chief clerk to the division superintendent, remaining in that position four years. He then was employed by the Illinois Central as train dispatcher on the Chicago, Madison & Northern division at Rockford, Ill., for three years, leaving to go to the Milwaukee, Lake Shore & Western as train dispatcher at Ashland, Wis. Later he was with the Southern Indiana as chief clerk to the general superintendent, chief train dispatcher and trainmaster. Mr. Bell entered the service of the Evansville & Terre Haute now a part of the Chicago & Eastern Illinois in 1906 as trainmaster. In 1910 he was promoted to superintendent, and continued as superintendent of the Evansville division of the Chicago & Eastern Illinois after the Evansville & Terre Haute was absorbed by the former road until June 15, when he was transferred to the superintendency of the Illinois division, as above noted.

R. C. Watkins, who on July 1 became superintendent of the Houston division of the Galveston, Harrisburg & San Antonio, with headquarters at San Antonio, Tex., was graduated in civil



R. C. Watkins.

engineering from the Agricultural and Mechanical College of Texas in 1895. From September, 1895, to January, 1897, he was with the Harriman Lines in Texas as track laborer, track walker and assistant yard foreman. He was then with the Juarez Construction Company, building 50 miles of the Rio Grande, Sierra Madre & Pacific in Mexico, leaving that company in May, 1898, to go with the Edison Electric Company of New Orleans as engineer. Mr. Watkins returned to active railway service in January, 1899, as assistant engineer of construction and maintenance of the Louisiana Western and Morgan's Louisiana & Texas Railroad & Steamship Company. From June, 1902, to June, 1904, he was successively resident engineer of the Harriman Lines at San Antonio, Tex., and office engineer at Houston, Tex. He was then made right of way agent of the Harriman Lines in Texas and Louisiana, which position he held until June of this year, when he was promoted to acting superintendent of the Houston division of the Galveston, Harrisburg & San Antonio, one of the lines of the Sunset Route of the Southern Pacific. The appointment was made permanent July 1, as above noted.

Vice-President and General Manager J. P. O'Brien of the Oregon-Washington Railroad & Navigation Company, announces that effective July 1 the offices of assistant general managers are abolished and the following appointments made: M. J. Buckley, general superintendent, with headquarters at Portland, Ore.; C. G. Sutherland, assistant to general manager, with office

at Portland; J. L. Brass, assistant to general manager, with office at Seattle, Wash.; E. A. Klippel, superintendent of telegraph, and S. A. Hering, car service agent, both with headquarters at Portland. The operating divisions of the company will be as follows: First division, comprising the Northern division lines and that portion of Oregon division lines, Umatilla and west; Second division consisting of that portion of Oregon division lines east of Umatilla; Third division, including the lines now designated as Yakima division; Fourth division, comprising the lines now designated as the Washington division; Fifth division, including the lines now designated as the Ilwaco division and Water lines. J. D. Stack, heretofore assistant general manager, is appointed superintendent of the first division, with headquarters at Portland. W. Bollons is appointed superintendent of the Second division, with office at LaGrande, Ore. The following officials will have jurisdiction over the entire First division, with headquarters at Portland: W. H. Guild and W. M. Jaekle, assistant superintendents; A. B. Moore, division storekeeper. J. D. Matheson is appointed an assistant superintendent of the First division, with office at Portland. The office of assistant superintendent at Seattle is abolished.

#### Traffic Officers.

R. E. Hightower, Jr., has been appointed soliciting freight agent of the Macon & Birmingham, with office at Thomaston, Ga.

Leroy G. Smock, secretary to Vice-President MacMillan of the St. Paul & Kansas City Short Line, has been appointed division freight agent, with headquarters at Des Moines, Ia.

A. C. Shaw, assistant general passenger agent of the Canadian Pacific western lines at Winnipeg, Man., has been appointed general passenger agent, with office at Winnipeg, succeeding C. B. Foster, transferred to Montreal. R. G. McNeillie, district passenger agent at Calgary, Alta., succeeds Mr. Shaw and Robt. Dawson succeeds Mr. McNeillie.

H. P. Hewes has been appointed division freight agent of the Western Maryland, with office at Hagerstown, Md., succeeding T. H. McKoy, resigned. T. T. Adams has been appointed traveling freight and passenger agent, with office at Norfolk, Va. R. B. Machmer has been appointed traveling freight agent, with headquarters at Reading, Pa., and George J. Davis has been appointed soliciting freight agent, with office at Philadelphia, Pa.

Edward M. Kain, division freight agent of the Erie at Elmira, N. Y., has been appointed assistant general freight agent, with headquarters at Buffalo, succeeding Herbert Thompson, resigned to engage in other business. George C. Manning, division freight agent of the New York and the Delaware divisions, at New York, succeeds Mr. Kain. George R. Wheeler, division freight agent of the New York, Susquehanna & Western, at New York, succeeds Mr. Manning, and Lester R. Knapp has been appointed division freight agent, succeeding Mr. Wheeler.

F. W. Parsons, manager of the Eastern & Southern Despatch, has been appointed manager of eastern agencies (all rail) of the Southern Railway with headquarters at Philadelphia, and G. H. Kerr at Pittsburgh, Pa., W. M. Israel at Rochester, N. Y., Robert Mayo, Jr., at Philadelphia, Pa., and D. L. Taylor at Boston, Mass., formerly agents of the Eastern & Southern Despatch, are now commercial agents of the Southern Railway at the same places, and exclusive agencies of the Eastern & Southern Despatch Line are discontinued. The Eastern & Southern Despatch Route is not affected by this change. Southern Railway representatives will continue to handle the business of that despatch line under the supervision of Mr. Parsons.

C. A. Russell, commercial agent of the Southern Railway at Charlotte, N. C., has been appointed commercial agent at Memphis, Tenn. H. A. Parker succeeds Mr. Russell. R. H. McDonald, freight soliciting agent at Columbia, S. C., has been appointed commercial agent, with office at Columbia, and his former position has been abolished. C. D. Brown, traveling freight agent at Abbeville, S. C., has been appointed commercial agent, with office at Greenwood, S. C., and his former position has been abolished. S. H. Wiles has been appointed traveling freight agent, with office at Pittsburgh, Pa. I. I. Norris has been appointed traveling freight agent, with office at Rochester, N. Y., and W. S. Fargo has been appointed freight soliciting agent, with office at Augusta, Ga., succeeding F. E. Harrison, transferred.

#### Engineering and Rolling Stock Officers.

Lee Barnes has been appointed assistant roadmaster of the St. Paul division of the Northern Pacific.

H. J. Osborne has been appointed superintendent of motive power of the South Dakota Central, with headquarters at Sioux Falls, S. D.

The office of master car builder of the Missouri, Kansas & Texas at Sedalia, Mo., heretofore held by W. A. Mitchell, has been abolished.

C. B. Daily, assistant superintendent of shops of the Chicago, Rock Island & Pacific, at Silvis, Ill., has been appointed master mechanic on the Cedar Rapids division, with headquarters at Cedar Rapids, Iowa, succeeding F. W. Williams, transferred.

F. S. Robbins, assistant general foreman, at the Pitcairn, Pa., car shops of the Pennsylvania Railroad, has been appointed assistant master mechanic, Pittsburgh division, with headquarters at Pittsburgh, succeeding C. D. Porter, promoted. J. H. Thomas, foreman at the Mifflin shops, succeeds Mr. Robbins.

G. H. Dryden, assistant signal engineer of the Baltimore & Ohio, at Baltimore, Md., has been appointed principal assistant signal engineer, with headquarters at Baltimore, and R. W. Taylor, assistant engineer at Baltimore, has been appointed assistant signal engineer, with headquarters at Baltimore.

P. T. Dunlop, mechanical superintendent of the Gulf, Colorado & Santa Fe, has been appointed general superintendent of motive power of the St. Louis & San Francisco, with headquarters at Springfield, Mo., succeeding George A. Hancock, who has resigned on account of ill health. Effective August 1.

J. F. Graham, assistant general manager of the Oregon-Washington Railroad & Navigation Company, has been appointed superintendent of motive power, and J. T. Langley, assistant general manager, has been appointed assistant superintendent of motive power, both with headquarters at Albina shops, Portland, Ore. Effective July 1.

R. S. Stephens, chief engineer of the Missouri Pacific system, having been assigned to duties in connection with the valuation of railways by the Interstate Commerce Commission, C. E. Smith, bridge engineer, has been appointed assistant chief engineer, with headquarters at St. Louis, Mo., and will temporarily assume the duties of the office of chief engineer.

W. H. Scribner has been appointed supervisor of mechanical examinations of the Lake Shore & Michigan Southern, the Dunkirk, Allegheny Valley & Pittsburgh, the Chicago, Indiana & Southern and the Indiana Harbor Belt, with headquarters at Cleveland, Ohio, having direct assignment of duties in the examination of locomotive firemen for promotion, also for instruction of locomotive firemen at times not conflicting with examinations.

G. A. Hull, who recently was appointed superintendent of the car department of the Chicago, Rock Island & Pacific at Blue Island, Ill., has been appointed acting assistant mechanical engineer, with headquarters at Silvis, Ill., to succeed G. W. Lillie, who has been appointed acting mechanical superintendent of the Second district, with headquarters at Topeka, Kan., in place of C. M. Taylor, who has been granted a leave of absence due to illness. Effective July 10.

The Western Maryland announces that on July 15 the title of engineer maintenance of way was abolished, and for maintenance purposes the system has been divided into three divisions, as follows: Maryland division embracing all lines east of P. V. Junction, in charge of J. M. Harris, division engineer, with headquarters at Hagerstown, Md., succeeding J. Carmichael, assigned to other duties in the chief engineer's office. Cumberland division embracing all lines between P. V. Junction and Connelssville, Pa., including Knobmount yard, in charge of W. C. Kline, division engineer, with headquarters at Cumberland, and West Virginia division embracing all lines between Knobmount yard and Belington, W. Va., in charge of P. Cain, division engineer, with headquarters at Elkins.

G. W. Boschke, heretofore assistant general manager of the Oregon-Washington Railroad & Navigation Company, has been appointed chief engineer, with jurisdiction over the first division, south of the Columbia river, the second, third, fourth and fifth divisions, and construction work in progress adjacent to such lines, with the exception of the Spokane Union Ter-

minal, with headquarters at Portland, Ore. J. R. Holman, heretofore assistant general manager, has been appointed chief engineer, with jurisdiction over the first division, north of the Columbia river; also construction of Spokane Union Terminal and line westerly to Summit boulevard, Spokane, with headquarters at Seattle, Wash. H. L. Lyon has been appointed division engineer of the second division, with office at LaGrande, Ore. The jurisdiction of R. C. Charlton, signal supervisor, is extended to cover the entire first division.

#### Purchasing Officers.

J. H. Best has been appointed division storekeeper of the Second division of the Oregon-Washington Railroad & Navigation Company, with office at LaGrande, Ore. Effective July 1.

W. L. Cooper, division storekeeper of the Mobile & Ohio at Murphysboro, Ill., has been appointed division storekeeper at Jackson, Tenn., succeeding W. C. Blake, transferred. R. O. Woods, division storekeeper at Meridian, Miss., succeeds Mr. Cooper, and D. E. Moodie has been appointed division storekeeper at Meridian, Miss., succeeding Mr. Woods.

William P. Hawkins has been appointed assistant fuel agent of the Missouri Pacific and the St. Louis, Iron Mountain & Southern, with headquarters at St. Louis, succeeding W. J. Jenkins, resigned to become vice-president and general manager of the Consolidated Coal Company. Mr. Hawkins heretofore has been claims assistant in the office of Vice-President E. J. Pearson.

#### OBITUARY.

G. McRoberts, division foreman of the St. Louis & San Francisco at Salem, Mo., died on July 10, aged 56 years.

Paul R. MacKinnon, traveling passenger agent of the Chicago, Rock Island & Pacific at Denver, Colo., died recently at that place.

Henry Martyn Thompson, one of the first three railroad commissioners of the state of New York, died on Monday, July 14, at his home in New York at the age of 71.

Daniel Smith Newhall, purchasing agent of the Pennsylvania Railroad, died on July 13 in a hospital at Philadelphia. He was born on April 7, 1849, at Germantown, Philadelphia. On February 21, 1882, he was elected assistant secretary of the Pennsylvania Railroad, and since June 1, 1898, was purchasing agent of the same road, with office at Philadelphia.

David S. Hill, formerly from April, 1882, to February, 1900, general superintendent of the Lake Erie & Western at Indianapolis, Ind., died on July 1 at Detroit, Mich., aged 72 years. Mr. Hill began railway work in 1858, and filled various minor positions with the Michigan Central and Louisville, New Albany & Chicago until September, 1871, when he became assistant superintendent of construction of the Cincinnati, Lafayette & Chicago. Later he was trainmaster and superintendent of the Lafayette, Bloomington & Muncie until April, 1880, when he was made division superintendent of the Lake Erie & Western. In April, 1882, he was promoted to general superintendent, which position he held until February, 1900, when he was appointed assistant chief engineer of that road. He retired from active railway service in January, 1901.

Dr. William Taussig, president of the St. Louis Bridge Company, director of the St. Louis Union Trust Company and organizer and former president of the Terminal Railroad Association of St. Louis, died on July 10, of pneumonia, after an illness of several weeks, at his home in St. Louis, Mo., at the age of 87. He was born in Bohemia and was graduated from the University of Prague in 1844. He came to St. Louis a year later and was graduated in 1850 from the St. Louis School of Medicine. He was an active practitioner for thirteen years. In 1852 he was elected mayor of Carondelet. He served as judge of the St. Louis County Court from 1859 to 1865 and from 1863 to 1865 was the presiding judge. In 1866 he became president of the Traders' Bank. He was one of the organizers of the St. Louis Bridge Company, which built the Eads bridge, and of the Terminal Railroad Company. He was president of the Terminal Railroad Association from its organization in 1889, until 1896.

## Equipment and Supplies.

### LOCOMOTIVE BUILDING.

THE EL PASO & SOUTHWESTERN has ordered 5 mikado locomotives from the American Locomotive Company. These locomotives will be equipped with superheaters, will have 29 in. x 30 in. cylinders, 63 in. driving wheels, and in working order will weigh 325,000 lbs.

THE CHICAGO JUNCTION RAILWAY has ordered 5 six-wheel switching locomotives from the American Locomotive Company. These locomotives will be equipped with superheaters, will have 20 in. x 26 in. cylinders, 51 in. driving wheels, and in working order will weigh 149,000 lbs.

### CAR BUILDING.

THE DENVER & SALT LAKE is said to have ordered 175 freight cars from the Pullman Company. This item has not been confirmed.

THE EL PASO & SOUTHWESTERN has ordered 500 automobile cars, 200 stock cars and 200 gondola cars from the Standard Steel Car Company.

THE SOUTHERN RAILWAY, mentioned in the *Railway Age Gazette* of June 27 as having ordered 250 hopper cars from the Pressed Steel Car Company, has increased the order with that company to 345 hopper cars, and has ordered 100 hopper cars from the Lenoir Car Works. All of these cars will be of 100,000 lbs. capacity and will weigh 37,500 lbs. The inside dimensions will be 30 ft. long, 9 ft. 6 in. wide and 9 ft. high. The overall dimensions will be 31 ft. 10 in. long, 10 ft. ½ in. wide and 10 ft. high. Some of the special equipment will be as follows:

Body—Steel.	Door Fastenings—Enterprise Railway Equipment Co.
Underframe—Steel.	Draft gear—Miner.
Bolsters, body—Steel, built in.	Dust guards—Harrison.
Brakes—Westinghouse.	Journal boxes—Gould.
Brake beams—Waycott.	Side bearings—Cast on bolster.
Brake shoes—Perfecto, steel back.	Springs—Pittsburgh Spring & Steel Co.
Brasses—Ajax.	Trucks—American Steel Foundries.
Couplers—Buckeye.	Wheels—M. C. B.
Doors—Four.	

### IRON AND STEEL.

GENERAL CONDITIONS IN STEEL.—It is estimated that there has been a falling off of about 5 per cent. in mill operation since the latter part of June. A shrinkage in operations in July and August was to be expected, but the falling will be due as much to a decrease in specifications as to the hot weather. Many manufacturers believe that there will be a revival in the buying movement beginning in the fall, but doubt is expressed as to the ability of the steel industry to produce as large a tonnage in the last half of the year as in the first half.

### SIGNALING.

#### Automatic Block Signals on the Canadian Pacific.

The Hall Switch & Signal Company has recently taken contracts for the construction of automatic block signals on 47 miles of the Canadian Pacific as follows: Montreal Junction to Iberville, 27 miles, double track; Markstray to Stinson 11 miles, single track; Renfrew to Egansville, 6 miles, single track; at Mattawa, 3 miles, single track. Switch indicators will be used in all of these installations, and the signals will be style K, top-post, normal danger.

The Canadian Pacific already has about 150 miles of its lines equipped with Hall automatic block signals, all normal danger, as follows: St. John to Vanceboro, 90 miles; West Toronto to Bolton, 21 miles, and Streetsville Junction to Islington, 13 miles, all single track but 1 mile; and Ste. Therese to Place Viger, 20 miles, and Romford to Sudbury, 7 miles, double track.

## Supply Trade News.

The General Electric Company, Schenectady, N. Y., has opened a branch office at Madison, Wis.

Fred Lavis, consulting engineer, who has been located in Argentina for the past 18 months, has returned to make his headquarters at his office at 50 Church street, New York.

The U. S. Metal & Manufacturing Company, New York, has recently added to its line of railway specialties, the sale of the Lincoln arc welding and cutting machines, made by the Welding Materials Company.

The H. W. Johns-Manville Company, New York, has opened a branch office in the Commercial Bank building, Charlotte, N. C., in charge of E. U. Heslop as manager. P. J. McCusker and Paul W. Whitlock are also located at that office.

The Independent Pneumatic Tool Company, Chicago, has moved its motorcycle manufacturing department from its plant at Aurora, Ill., to a new plant in Chicago, to permit further expansion in the manufacture of its Thor air and electric tools. The output of the Aurora plant will be increased to 1,500 air tools and 500 electric drills per month.

A fire broke out on Saturday night, July 12, in the lumber yards of the Haskell & Barker Car Company at Michigan City, Ind., and for a time threatened to destroy the entire plant and a large part of the city. Several million feet of lumber was destroyed, causing a loss which has been estimated at over \$500,000, but the fire was controlled before it extended to other parts of the plant.

The Westinghouse Electric & Manufacturing Company, Pittsburgh, Pa., has sold to Kuhn, Loeb & Company, New York, \$3,250,000 6 per cent., two-year notes, due August, 1915, to provide for the retirement of the \$4,000,000 6 per cent., three-year notes due August 1, next. The remaining \$750,000 will be paid out of the treasury of the company. A cash payment of \$10 for each \$1,000 note will be paid to the holders of the old notes who exchange them for new notes.

District Judge Thomas I. Chatfield, sitting in the United States district court for the Eastern district of New York, handed down a decision on June 12 in *Heinrich L. I. Siemund vs. Joseph Enderlin, Sr., and Joseph Enderlin, Jr., doing business under the firm name and style of Joseph Enderlin, Jr., & Co.*, dismissing the complaint against the defendants for infringement on electrical welding patents. It was found that the complainant, the defendants and others had been applying the teachings of the Bernados method of electrical welding, as improved upon by Coffin and Kjellberg through the use of a metal electrode. They had found that under certain relative conditions of size of parts and strength and quantity of current, an experienced workman could weld upon an overhead surface, but Siemund was the first man who described to the patent office, or who expressed in writing a definite description of the proportion and arrangement of the entire apparatus and the method of the manipulation of the parts when making a successful overhead weld. The court found that such a description was not the invention of a method; also that an arrangement of the parts of a device cannot be patentable as a new invention when the earlier patents show both an understanding of the possibility of these results and the existence of such an arrangement of parts and of the conditions produced, even though the explanation of the cause of the results themselves be mistakenly stated. For seven or eight years prior to the Siemund experiments, Enderlin was welding by the method of electric current, of substantially the proportions needed for the Siemund method, and by the use of a metallic electrode of such small size as to produce a voltaic arc, manipulated in almost the identical way which Siemund later patented. The court decided that even if the particular improvements upon the Bernados method were patentable, or if the particular device showed patentable novelty, the Siemund patent must be held invalid when tested from the standpoint of the defendant's prior use.

INDO-CYLON RAILWAY CONNECTION.—Work on the Indo-Ceylon connection, South Indian Railway, is proceeding steadily. More than two-thirds of the earthwork is finished.

## Railway Construction.

ALGOMA CENTRAL & HUDSON BAY.—The Algoma Eastern has been extended from Crean Hill, Ont., southwest to Espanola, 26 miles.

ALGOMA EASTERN.—See Algoma Central & Hudson Bay.

ALVA & NORTHWESTERN.—Under this name a line is projected from Alva, Okla., it is said, northwest to a connection with the Chicago, Rock Island & Pacific at Bucklin, Kan., about 80 miles. W. E. DeFord, Billings, Mont., is the promoter.

BIRMINGHAM & SOUTHEASTERN.—This road has been extended from Tallassee, Ala., north to Electric, 14 miles.

BUTTE-BOISE-WINNEMUCCA.—An officer of this company, which was recently incorporated in Idaho, with \$40,000,000 capital, is quoted as saying that construction work will be started at once on a section extending east and west from Boise, Idaho. The plans call for building from a point near Anaconda, Mont., south to Armstead, thence via Salmon City, Idaho, and southwest via Challis to Boise City, then through Oregon to Winnemucca, Nev. L. O. Leonard, Boise, is president. (June 13, p. 1342.)

CALGARY & FERNIE.—The subsidy voted by the Canadian government in 1912, for a line from a point between Michel, B. C., and Sparwood northerly via the headquarters of Elk river and Kananaskis Pass to Calgary, Alta., 100 miles, has been renewed. Work on the line is to be started from a point near Fernie. The directors include G. A. Fraser and S. S. Mahon.

CANADIAN PACIFIC.—A new branch of the Esquimalt & Nanaimo, called the Cowichan Lake subdivision, has been opened for business from Hayward Junction, B. C., west to Cowichan Lake, 18 miles.

CORINTH & NORTHEASTERN.—This company, which was recently organized by residents of Corinth, Miss., is making financial arrangements to build from Corinth, Miss., northeasterly to the Tennessee river and to Savannah, Tenn. The plans call for ultimately extending the line to Nashville. The city of Corinth proposes to issue bonds for \$50,000 to provide terminal facilities in that city, and the county of Hardin to issue \$100,000 of bonds in aid of the project. Clopton Thomas, secretary of the Business Men's Club, Corinth, may be addressed. (June 6, p. 1244.)

ESQUIMALT & NANAIMO.—See Canadian Pacific.

GRAND RAPIDS & INDIANA.—The line, formerly in operation between Cadillac, Mich., and Lake City, has been extended from Lake City to Falmouth, 8.6 miles.

GRAND TRUNK PACIFIC.—A new line has been opened for business on the Prairie division, called the Oban & Battleford subdivision, from Oban, Sask., north to Battleford, 48.5 miles.

HALIFAX TERMINAL.—See Intercolonial Railway.

INTERCOLONIAL RAILWAY.—Contracts have been given to the Cook Construction Company, Sudbury, Ont., and to A. B. Wheaton, Amherst, Nova Scotia, it is said, for building a five mile line from Rockingham, Nova Scotia, under the name of the Halifax Terminal. It is understood that the contracts are worth \$1,500,000.

KNOXVILLE & MARYVILLE INTERURBAN.—Application is to be made for a charter in Tennessee, it is said, by this company, with capital of \$10,000. The plans call for building from Vestal, Tenn., south to Maryville, about 15 miles. The line may eventually be extended southwest to Madisonville, in all about 45 miles. H. Cornick, C. M. Seymour and R. M. Mitchell are incorporators.

MARGAREE COAL & RAILWAY.—The Canadian parliament has granted this company a subsidy, not to exceed \$6,400 a mile, in place of the subsidy voted in 1911, for the following lines: From the Intercolonial Railway near Orangedale, N. S., to St. Rose, 46 miles; from a point on the same road near McIntyre Lake, to Caribou Cove, Port Malcolm, 4 miles. Construction work has not yet been started, but it is understood that financial arrangements have been made for carrying out the work at once. A. W. Chisholm, J. D. Taylor, C. E. Sherman and T. S. Courteney are interested.

## Railway Financial News

**MARYVILLE-KNOXVILLE INTERURBAN.**—Organized with \$10,000 capital and headquarters at Knoxville, Tenn., it is said, to build a 14-mile line from Maryville north to Knoxville. T. G. McConnell and J. H. Frantz are interested.

**NAAS VALLEY & NORTHERN.**—Incorporation has been asked for in Canada by this company, to build from the mouth of the Naas river to Stikeen river, British Columbia, thence northerly along Teslin lake to Yukon territory. Smith & Johnston, Ottawa, Ont., are solicitors for the applicants.

**OAKWOOD & TRINITY RIVER SOUTHERN.**—Incorporated in Texas with \$100,000 capital, and principal office at Oakwood, Leon county. The plans call for building from a point on the International & Great Northern in Leon county, not yet decided upon, south through Leon county to a point in Madison county about 50 miles. The incorporators include J. M. Dobie, W. A. Frisby, J. H. Haile, W. W. Collier and L. Frisby, all of San Antonio; J. W. Barton, Oakwood, and F. S. Streater, Dallas.

**OREGON SHORT LINE.**—A new branch, called the Homedale branch, has been opened for business on the Idaho division from Nyssa, Ore., south to Homedale, Idaho, 25 miles, and a branch on the Montana division has been opened for business from Elva, Idaho, to Menan, 10 miles.

**OLYMPIA SOUTHERN.**—Incorporated in the state of Washington with \$100,000 capital, it is said, to build from Puget Sound to the Columbia river. T. R. Brown, Olympia, and B. H. Rhodes, Centralia, are incorporators.

**PAWUSKA & NORTHEASTERN.**—Incorporated in Oklahoma, with a capital of \$100,000, to build from Pawhuska, Okla., on the Midland Valley northeast to Bartlesville, also to build from Pawhuska west to Ponca on the Atchison, Topeka & Santa Fe. The incorporators include W. C. Tucker, W. T. Leahy, E. J. McCurdy, A. W. Hurley and H. H. Brenner, Pawhuska.

**PINE BLUFF & SOUTHERN.**—The Railroad Commission of Arkansas has extended to February 15, 1915, the time in which the company shall build 10 per cent. of the line from McCreanor, Ark., south to Pine Bluff, about 40 miles.

**ST. LOUIS, IRON MOUNTAIN & SOUTHERN.**—On the Memphis division a new branch has been opened for business, called the Marianna branch, from Memphis, Tenn., south to Marianna, Ark., 51 miles.

**SALEM, FALLS CITY & WESTERN.**—This road has been extended from West Salem, Ore., to Salem, 1.4 miles.

**SAN ANTONIO, UVALDE & GULF.**—The Gulf division has been extended from Whitsett, Tex., south to Kitty, 16.8 miles.

### RAILWAY STRUCTURES.

**COCHRANE, ONT.**—Bids are wanted by P. E. Ryan, secretary of the Commissioners of the Transcontinental Railway, at Ottawa, Ont., until July 22, 1913, for building an ice house, store house, freight house, and two tool houses at Cochrane, Ont. Plans on file at the offices of Gordon Grant, chief engineer, Ottawa, and of T. S. Armstrong, district engineer, Cochrane.

**PHILMONT, PA.**—An officer of the Philadelphia & Reading writes that a contract has been given to Enos L. Seeds, Philadelphia, Pa., for putting up a brick and hollow tile passenger station at Philmont on the New York branch in Montgomery county. The structure is to be 29 ft. high, 33 ft. wide, and 38 ft. 3 in. long.

**PITTSBURGH, PA.**—Plans for the North Side freight station of the Pennsylvania Railroad are being made, and it is expected that construction work will be started this summer. The station will extend along North Canal street, from Federal to Anderson streets, for a distance of 912.9 ft. The structure will be of brick construction with terra cotta trimmings. It will consist of a four-story office structure fronting Federal street, with a two-story warehouse extending back to Anderson street, the second story spanning Sandusky street. The tracks are to enter the building at the height of the second floor. Between it and the Fort Wayne roadbed five additional tracks and a covered transfer platform more than 1,000 ft. long will be constructed. The contract for the work has not yet been let.

**CASSVILLE & WESTERN.**—This five-mile road, running from Cassville, Mo., to Exeter, has been sold under foreclosure for \$31,050.

**MISSOURI, KANSAS & TEXAS.**—This company has bought the Sugar Land Railroad. The Sugar Land Railroad runs from Cabell, Tex., to La Preme, 19 miles.

**NEW ORLEANS, TEXAS & MEXICO.**—Vice-President and General Manager A. D. Lightener has been appointed temporary receiver of this subsidiary of the St. Louis & San Francisco.

**NEW YORK CENTRAL & HUDSON RIVER.**—United States Senator Norris, of Nebraska, has introduced a resolution in the Senate providing for an inquiry into the New York Central's proposed plan for merging its property with the Lake Shore & Michigan Southern.

**NEW YORK, NEW HAVEN & HARTFORD.**—See New York, Westchester & Boston.

**NEW YORK, WESTCHESTER & BOSTON.**—The *Wall Street Journal* says that in June, for the first time, this subsidiary of the New York, New Haven & Hartford, which was built at a cost of approximately \$35,000,000, earned its operating expenses. The fixed charges on the investment are, of course, still being carried by the New Haven.

**NORTHERN PACIFIC.**—The First National Bank, the National City Bank and J. P. Morgan & Co., all of New York, bought from the railroad company and have entirely sold \$10,000,000 one-year 6 per cent. notes of the Northern Pacific. The price at which the notes were issued was 99 $\frac{3}{4}$ . The notes are a general credit obligation of the railroad.

**OAKLAND, ANTIOCH & EASTERN.**—The California railroad commission has authorized this company to issue \$1,000,000 additional first mortgage 5 per cent. bonds, making the total amount of outstanding bonds \$4,000,000.

**ST. LOUIS & SAN FRANCISCO.**—M. de Peyster, who has been one of the inspectors of the Minister of Finance of France, has been ordered by the French government to make an investigation of the financial position of the St. Louis & San Francisco.

See St. Louis, Brownsville & Mexico and New Orleans, Texas & Mexico.

**ST. LOUIS, BROWNSVILLE & MEXICO.**—Frank Ball, of Houston, of the firm of Andrews, Ball & Streetman, has been appointed receiver of this subsidiary of the St. Louis & San Francisco.

**SUGAR LAND RAILROAD.**—See Missouri, Kansas & Texas.

**WABASH.**—See Wheeling & Lake Erie.

**WHEELING & LAKE ERIE.**—Under the direction of the court, the Wabash, on August 1, will default on the interest on the Wheeling & Lake Erie notes, which are guaranteed principal and interest by the Wabash. The notes, originally amounting to \$8,000,000, now amount to about \$10,000,000. The Wabash had been paying interest on these notes for the past year under an agreement with the noteholders, but the court now holds that it can no longer pay this interest.

**IMPORTANT CHINESE RAILROAD PROPOSED.**—The most important railway that has been projected in China for many years is that which is destined to connect the sea with Lanchow, the capital of Kansu province. It will pass through four provinces, Kansu, Shensi, Honan and Kiangsu, and therefrom it derives its name, the "Lung-Tsing-U-Hai Railway"—"Lung," meaning Kansu, "Tsing," Shensi, "U," Honan, and "Hai," the sea. It will pass through Sian-fu (the capital of Shensi province), Tung-kwan, Honan-fu, Kaifeng-fu (the capital of Honan province), Kweiteh-fu, and Suchow-fu in the province of Kiangsu, to the sea. It will also penetrate one of the most important sections of China on its way from Honan westwards, by following the famous Tungkwan road. This is probably the greatest military road in China, and is supreme in importance in a strategic and political aspect, as it mediates without exception the natural traffic between the southwest of the republic and Peking.

# Railway Age Gazette

PUBLISHED EVERY FRIDAY AND DAILY EIGHT TIMES IN JUNE, BY THE  
SIMMONS-BOARDMAN PUBLISHING COMPANY,  
WOOLWORTH BUILDING, NEW YORK.

CHICAGO: Transportation Bldg. CLEVELAND: Citizens' Bldg.  
LONDON: Queen Anne's Chambers, Westminster.

E. A. SIMMONS, President.

L. B. SHERMAN, Vice-President. HENRY LEE, Sec'y & Treas.  
The address of the company is the address of the officers.

### EDITORS.

SAMUEL O. DUNN, Editor.

ROY V. WRIGHT, Managing Editor.	H. H. SIMMONS	E. S. FAUST
W. E. HOOPER	H. F. LANE	F. W. KRABER
B. B. ADAMS	E. A. AVERILL	A. D. CLOUD
E. T. HOWSON	R. E. TEAYER	GEORGE L. FOWLER
	A. C. LOUDON	

Subscriptions, including 52 regular weekly issues and special daily editions published from time to time in New York, or in places other than New York, payable in advance and postage free:

United States and Mexico.....	\$5.00
Canada .....	6.00
Foreign Countries (excepting daily editions).....	8.00
Single Copies .....	15 cents each

Engineering and Maintenance of Way Edition and four Maintenance of Way Convention Daily issues, North America, \$1.00; foreign, \$2.00.

Entered at the Post Office at New York, N. Y., as mail matter of the second class.

WE GUARANTEE, that of this issue 8,150 copies were printed; that of these 8,150 copies, 6,694 were mailed to regular paid subscribers and 245 were provided for counter and news companies' sales; that the total copies printed this year to date were 289,458—an average of 8,648 copies a week.

VOLUME 55. JULY 25, 1913. NUMBER 4.

## CONTENTS

### EDITORIAL:

Editorial Notes .....	133
The Personnel of the Mediation Board.....	134
The Human Element in Industrial Management.....	135
New Books .....	135

### LETTERS TO THE EDITOR:

The Stoker vs. Powdered Fuel for Locomotives; by Clement F. Street	137
Fallacy of the Equated-Revenue Cost Unit; by Owen Ely.....	137
Relative Value of Service for Passengers and Freight; by W. F. Turnbull .....	138
With the Authority Goes the Responsibility.....	138
Why Give Passes to Employees? by E. L. McColvin.....	138
"The Significance of the State Rate Case Decisions"; by H. T. Newcomb .....	139

### MISCELLANEOUS:

The Question of Increased Freight Rates; by A. B. Hult.....	140
Fighting the Boll Weevil East of the Mississippi.....	142
*Extensive Improvements on the L. & N.....	143
*Benjamin F. Bush.....	150
Mediation of Trainmen's Demands.....	150
*General Foremen's Association.....	151
*The Board of Conciliation and Mediation.....	155
*A Day's Train Record Over Tehachapi Mountain.....	155
Tool Foremen's Association .....	158
Foreign Railway Notes .....	149, 150, 154, 157

### GENERAL NEWS SECTION..... 160

\*Illustrated.

**MR. MELLEN**, in resigning from the New York, New Haven & Hartford, acted in a way consistent with his entire record as a railroad president. Charles S. Mellen is without doubt one of the most remarkable men who have ever been at the head of a great American railroad system. Entrusted with great power and burdened with a tremendous responsibility, Mr. Mellen took counsel with none; he planned out his own course, and after once deciding that it was the proper course, he followed it with an undeviating, uncompromising directness that has seldom been equaled outside, possibly, of military history. There have been strong arbitrary railroad presidents be-

fore Mr. Mellen, most of them of what is nowadays spoken of as the old school; in the majority of cases they have been owners as well as officers, but in the history of each one of them may be found instances of compromise, of acceptance of advice and of conciliation. Not so with Mr. Mellen's administration of the New Haven. Furthermore, when he finally became convinced that the New Haven's affairs could be better managed by some one else, his decision was given to his board of directors as absolute and final. Probably there is no better comment on Mr. Mellen's character and strength than the manner of the acceptance of his resignation by a board of directors which includes many of the strongest and most successful men in American business. In resigning Mr. Mellen stated his unalterable belief that his policies had been right and that time would prove them right, and accepted the fact that his manner of carrying them out would probably make them more difficult of accomplishment than would the manner of some less arbitrary and rigid successor.

**WHILE** railway executives, lawyers and others are pondering on the effects of the recent decisions of the Supreme Court in the state rate cases, there is one very practical aspect of the case, which for some time to come will overshadow all broader questions relating to the decision in the minds of passenger officials and rate men whose duty it is to put the court's mandate into effect. Although not exactly a part of the case, one of its most important direct effects is to bring the railways face to face with the stupendous problem of readjusting their interstate fares to conform to the provision of the long and short haul section of the Mann-Elkins law, which prohibits the charging of through interstate rates higher than the combination of intermediates. This must be accomplished, according to the Interstate Commerce Commission's rulings, by May 1, 1914, and railway passenger officers are wondering where they are going to find rate clerks enough even to make an impression on the job in that length of time. One of the practical realities of state regulation, which the Supreme Court did not feel called upon to consider deeply, is that the reduction of all passenger rates in Wisconsin, for example, involves interstate rates from the Atlantic to the Pacific. While the long and short haul clause does not apply to state rates, these of course affect the local interstate rates on which are based the long distance through rates between all parts of a broad nation, and apparently they have all to be checked against all possible combinations of locals. It is true that the over-confidence of the railways that the Supreme Court would knock out the state rates is largely responsible for the fact that they have the entire task before them now. The law went into effect July 1, 1910, and the roads have delayed action under extension of time granted by the commission, hoping that the state rates would be defeated. Many interstate fares have already been lowered by state legislation, particularly rates to points near state borders and rates based thereon, but many more rates will now have to be reduced which have not yet been readjusted. Aside from the vast labor and expense of such a complex revision the reduction of interstate fares will naturally have an important effect, which is now almost beyond estimate on passenger revenue.

**AT** the annual conventions of the firemen's and the engine-men's brotherhoods recently held in Chicago and Washington, the long-standing differences between the two organizations, concerning their relative standing in the conduct of negotiations with railroad companies, has been settled; a development which will be a decided relief to many railroad officers. This action, in effect, means that the brotherhoods as a whole have decided to follow the sensible course which has long prevailed on the New York Central, where the general committees have had a thorough understanding with the management of the road which has

worked to the satisfaction of both sides, and without friction. In brief, this arrangement is that in questions concerning wages the management shall deal with only one committee for each class, while in the matter of grievances this rule is not insisted on. On wages there is one committee for enginemen and one for firemen. For the enginemen the committee is composed, of course, of members of the enginemen's brotherhood. This committee acts in the interest of all enginemen, whether they be members of the enginemen's brotherhood or the firemen's, or if no brotherhood. For the firemen the committee is dominated, naturally by the firemen's brotherhood. The agreement consists of fifteen articles. The principal one is article No. 1, in which it is agreed that the right to make and interpret contracts, rules, rates and working agreements for locomotive engineers shall belong to the B. L. E. and for firemen and hostlers to the firemen's brotherhood. The rights of any engineer, fireman or hostler to have the regular committee of his organization represent him in case of a grievance is conceded. [That is to say, an engineman may have for his advocate a committee of the firemen's brotherhood if that is the organization to which he belongs; or, as an officer of the New York Central puts it, a man who is in trouble may get help wherever he can. His advocate may be a lawyer, a priest, a shoemaker, or simply his "next friend."] Elaborate provisions are made in this agreement for joint action, and, conditionally, for temporary joint committees; and the procedure in case of disagreement or deadlock is carefully defined. Men may be members of both brotherhoods, on paying dues, etc., but men belonging to both shall not serve on committees. If the B. L. E. should order a strike it would not require its members who are firing to quit their positions; and vice versa. Article No. 10 contains elaborate provisions about promotion and seniority, apparently an outline for use in making demands on employers. These details, however, are of immediate interest only to members of the brotherhoods. To railroad officers the significant feature is the agreement to bury the hatchet. Assuming that the local officers of the unions will carry out this idea in the spirit in which it has been adopted in the conventions as, no doubt, they will, a prolific source of irritation will be done away with.

#### THE PERSONNEL OF THE MEDIATION BOARD.

PRESIDENT WILSON has selected William Lee Chambers as commissioner of the board of conciliation and mediation provided for by the Newlands bill, and Judge Martin A. Knapp as one of the two other members of the board. Judge Chambers was the third and deciding member of the arbitration board which heard the firemen's case for higher wages, and it is, of course, natural to turn to his record in this proceeding to form a judgment of the man. In it he showed himself honest, generous, warm-hearted and thoroughly a man to be respected; furthermore he showed tact and was in a way the embodiment of conciliation.

The duties of the three men who form the board of arbitration are of very great importance, but they do not, it must be remembered, include the final arbitration proceedings themselves. It is the duty of this mediation board, in the first place, to bring the two sides of the controversy together on the points which are to be submitted to arbitration. This in itself is a delicate task and one which Judge Chambers is eminently fitted for. After a case has been prepared for arbitration, each side to the controversy is to select two men, and these four men are to try to select two impartial men to complete the board of six, whose duties it will be to actually hear the two sides to the controversy and to render the final decision. Needless to say, it is hardly within the bounds of possibility that the four men who will be selected by the employees and the railroad companies in the pending trainmen's controversy will be able to agree on two other men to complete the board. It will thus devolve on Judge Chambers and his two associates to select the two im-

partial members of the commission which will pass on the trainmen's demands. In this will lie the greatest opportunity and the greatest responsibility of the mediation board. In the selection of these two men there will be required courage and judgment of a very high order. Tact, conciliation, compromise—all those things that will be highly fitting and proper in the preparation of getting the two sides to the controversy together—would be, in the final selection of the two impartial arbitrators, wholly out of place and tantamount to failure to recognize the solemn responsibility which has been placed on the mediation board.

In passing upon the firemen's contentions Judge Chambers, as we have said, showed tact, uprightness and fairness. On the other hand, it struck an observer, who followed the proceedings with care, that Judge Chambers' mind was made up, at least in regard to the attitude which he would take, before the hearings took place at all. His questions during these hearings appeared to indicate that during the time he was presiding his mind was following a certain course on which he had decided previous to coming to the proceedings. As certain points were brought up in the testimony they apparently coincided with or went against certain opinions arrived at in the natural course of Judge Chambers' reasonings, and when this occurred it called forth questions and at times an analysis of either the railroads' or the employees' contentions, but did not, apparently, materially change the course of Judge Chambers' thoughts. In other words, Judge Chambers apparently reasoned *a priori* rather than deductively.

It is earnestly to be hoped that the mediation board, in selecting two men to pass on the trainmen's controversy, will succeed in finding two strong, uncompromising, honest men who will face the situation that will be presented to them, and who will finally decide the very momentous question which they will have to decide purely on the merits of the case itself as it is presented to them and in the light of principle, not of compromise.

From the trainmen's own point of view and from the point of view of the future good of the brotherhoods, it is of the greatest importance first, that in this demand of the trainmen, the case for both sides be presented fully and well; second, that it be analyzed and passed on by men capable of uncompromising analysis. In this way only can there be put before the public, the fellow-workers of the brotherhoods, and the railroad managers, the merits of the controversies stripped of all side issues of prejudice and of selfishness. It must be remembered that the brotherhoods are only between 10 and 15 per cent. of the total number of railroad employees. The arbitrators who are to finally pass on the trainmen's demands should have presented to them not only the side of the managers and the side of this small minority of employees, but also the side of the great majority of railroad employees from whom organized labor is now attempting to snatch every dollar that the railroads can put into increased wages.

There is an opportunity presented here for the railroad managers to take a broader stand than they have ever heretofore taken in any wage controversy with organized labor and to present not only the narrow hand-to-mouth sort of arguments that have so often been presented in the past, but to present the whole serious case with its far-reaching effect on *railroad labor that is not organized*, and on all relations between employer and employed, as well as the immediate comparatively narrow interests which the managers represent.

The profound study of all sides of a question that was made by the Hadley commission into the possibilities of the regulation of the issuance of securities is the kind of investigation that should be made in the wage controversy, and there were two men at least on that commission, President Hadley and Commissioner Meyer, who are the type of men who ought to be selected by the mediation board to act as the impartial arbitrators whom they will be called on to select.

### THE HUMAN ELEMENT IN INDUSTRIAL MANAGEMENT.

ONE of the sessions of the joint meeting of the Verein Deutscher Ingenieure and the American Society of Mechanical Engineers, which was held in Leipzig, Germany, the latter part of June, was given over to a consideration of industrial management. Two papers were presented, one by James Mapes Dodge, of Philadelphia, and the other by Professor G. Schlesinger, of Germany. Professor Schlesinger gave an analysis of industrial management under the title of "Practical and Scientific Management," using material which was very largely drawn from American sources. He directed attention, among other things, to the fact that the German people, who for centuries have been accustomed to obedience to superiors, to methodical instruction, to observing written reports of the fullest description and to compulsory service, should help Germany to quickly take full advantage of the results of scientific management and thus regain any temporary advantage which the Americans may have gained by the practical experiments along these lines which have been going on for a number of years.

Only three-tenths of one per cent. of the American workmen are now working under scientific management and the number will probably not increase very rapidly—at least, if we consider scientific management to mean the Taylor system—for the new movement has been exploited in such a way as to antagonize organized labor, and it will take a long time to overcome this prejudice. One of the fundamentals of the successful use of the Taylor system, and this was emphasized by Mr. Dodge, is intelligent co-operation between the employer and employee. To have such co-operation it is important that both parties cast aside their prejudices and study each other's conditions and interests carefully and with open minds. If this cannot be done, then any of the detail methods which are associated with the Taylor system are largely useless. Mr. Dodge has had as much experience with this system, from the viewpoint of the employer, as any one, and he frankly emphasized the fact that intelligent co-operation is the foundation of scientific management and that the employer and employee must have confidence in each other. It is worth while to quote the words with which he closed his address:

"After these conditions are brought about, all else is easy, and simply calls for an expenditure of time, patience and a desire to aid and assist. The details of scientific management so far as methods of time-keeping, pay, time-study, and all that goes with it, are concerned, have been ably presented. It is sufficient to say that none of these details is absolutely essential. All may be modified, provided that in making the modification positive conflict with other details is not developed. All must be done with a broad understanding and with the spirit of absolute faith in the outcome, and confidence in the triumph of truth, over error."

In commenting on the disadvantages of the Taylor system Professor Schlesinger mentioned the great difficulty of securing properly trained managers for installing and operating the new system. His specification for these men is as follows: "In order to procure a scientifically managed organization, engineers are required who are endowed with scientific minds and fully conversant with the methods of manufacture and their requirements today. Further, they are not only required to know theoretically the possibilities of work, but to be so clever and skillful practically, that they can even actively co-operate and remedy errors, and finally become such keen observers of human nature as to win the confidence of their workmen." It would be extremely difficult to find sufficient men of this type to take charge of a few of the industries; but when the extent of our American manufacturing and commercial industries is considered, it is readily apparent that Dean Gay, the head of the Graduate School of Business Administration at Harvard, was not far wrong when he estimated a few years ago that it would require two generations for the principles of scientific management to become at all generally accepted or the methods to be in vogue in any large part of the industrial field.

After all, then, the problem is almost entirely one of men—the developing of men who are big enough not only to under-

stand and appreciate the men under them and know how to handle them, but who, with the aid of all that science and practice combined can place at their disposal, will lead the men to eliminate all wasteful and inefficient efforts, and thus secure a maximum result with a minimum of effort.

A couple of years ago, when the enthusiastic exponents of scientific management called attention to the shortcomings of railways as they saw them, the emphasis was placed on methods. Today they are beginning to see that while methods are important, they are not nearly so much so as the human element in the problem. It must be admitted, however, that while the enthusiasts and the so-called efficiency engineers placed this emphasis wrongly, Frederick W. Taylor did not himself overlook its importance. In defining the philosophy of scientific management he summed it up in the following four principles:

*First:* The development of a science in place of "rule of thumb" for each element of the work.

*Second:* The scientific selection and training of the workman. *Third:* The bringing of science and the scientifically trained workman together through the co-operation of the management with the man.

*Fourth:* An almost equal division of the work and the responsibility between the management and the workmen, the management taking over all work for which they are better fitted than the workmen, while in the past almost all of the work, and the greater part of the responsibility, were thrown upon the workmen.

It will be noted that the second and third principles cover this problem of the human element. More and more we shall have to select our workmen and assign them to the work for which they are best fitted with the help of scientific investigation and study of their individual characteristics. After all, the problem of industrial efficiency will have to be solved, as it has in the past, by the development of strong executives who thoroughly understand the selection, training and handling of men, and who, in addition to this, will use all that science and practice can place at their disposal in developing methods to suit each special case, which will result in a maximum of efficiency with a minimum expenditure of energy.

---

### NEW BOOKS.

*Civil Engineers' Pocket-Book.* By Albert I. Frye. Size, 4 in. x 7 in.; 1,611 pages; flexible leather binding. Published by D. Van Nostrand Co., New York. Price, \$5.

The latest "Civil Engineers' Pocket-Book" is larger than any that have preceded it. The type used is smaller than the average of such books and in spite of the economy of space throughout, the number of pages is greater than in any of the earlier books. A thin grade of paper is used, but the volume is still two inches thick, making it questionable whether the name "pocket-book" can still be applied to such volumes, which, through the development of the profession, have grown to a size that makes them available only for desk and office use. The increased size of Frye's pocket-book is occasioned rather by the attempt to go into greater detail in each subject than by any broadening of the field which is treated. In general, the division of the book, the tables and data included, are very similar to the volumes already in use. The most noticeable feature of the book is the very large number of references to current literature on the subjects treated. At the close of each section a list of excerpts and references is given from which the user of the book can select a number of descriptions which go into much more detail than is possible in a pocket-book. The book has a very complete table of contents and an index to facilitate ready reference. A glossary of technical terms is also included in the book, and in addition there are a large number of illustrations, also drawings. In general, the typography and make-up are commendable.



## Letters to the Editor.

### THE STOKER VS. POWDERED FUEL FOR LOCOMOTIVES.

New York, July 9, 1913.

TO THE EDITOR OF THE RAILWAY AGE GAZETTE:

I have read with considerable interest the article entitled "Powdered Fuel for Locomotives," signed by Walter D. Wood, which appeared on page 13 of your issue of July 4, and also your editorial comment on the same subject.

I wish to take exception to the statement of Mr. Wood that we have about come to a standstill in the development of our steam power. From the standpoint of a machine for hauling traffic, the locomotive has during the past ten years been improved to a greater extent than in any other like period since the first locomotive was built. The introduction of locomotives of greater weight and power, the introduction of superheaters, brick arches, stokers, and other devices, have permitted the production of locomotives having a hauling capacity which ten years ago would have been considered impossible. In view of the fact that some of the greatest improvements have been made within the past two or three years, there is no reason for believing that the development has come to a standstill, and there is on the other hand every reason to believe that marked additional improvements will be made. One of the greatest lines for improvement is undoubtedly in the firing of the locomotive. The present system of putting coal in a firebox with a shovel is very crude, and, from a theoretical standpoint, just about as near wrong as it could be done. As a consequence, the variation in the results secured by different firemen on the same road and on the same locomotive is from 25 to 35 per cent., or even greater. With the introduction of stokers and other improvements, this variation can be practically eliminated. The introduction of powdered fuel may be one of the solutions of this problem, but there are many serious difficulties in the way.

Mr. Wood makes the statement that: "Practically all of the biggest Mallets have, or have had, stokers of various types at some time or other, most of them having proved inadequate when the most trying conditions were imposed upon them." I wish to take exception to that statement. I know of only two or three cases where stokers have been removed from large Mallet locomotives because they proved inadequate, and at the present time over one hundred large Mallet locomotives are being successfully fired with stokers, and stokers are being applied to 30 or 40 additional locomotives of that type. The largest coal-fired Mallet locomotives in existence, having a tractive effort of 115,000 tons, are being successfully fired with stokers.

Mr. Wood makes the statement that the electrification of roads must come unless smoke is abolished—not partially, but entirely. This is certainly a very radical statement from a railroad man, as it is in line with the general persecution of railways which has been in vogue in this country for some years past. If railways are to be compelled to entirely eliminate smoke, why should not steamboats, factories, office buildings and residences be compelled to do the same thing? One proposition is just as unreasonable as the other. It is just as practicable to run all power plants with electric power, to heat all buildings with electricity, to heat all houses and do all cooking with electricity, as it is to run all railways by electric power; that is, at the present stage of the development of the electric art.

I have sat in a window and watched the smoke stacks of hotels, office buildings and manufactories belching forth clouds of black smoke continuously, while inspectors in the same city were perched in a line along the right-of-way of a railroad taking the numbers of locomotives which were producing only a fraction of the quantity of smoke produced by the stacks re-

ferred to, and arresting and fining the firemen and engineers for producing smoke, while no action whatever was taken regarding the other smoke producers. No reasonable man or body of men would for one moment maintain that this was just to the railroads, but it is what is being done from one end of this country to the other, and is one of the most serious of the many persecutions which the railways are experiencing at the hands of so-called legislators.

As stated above, it may be that powdered fuel will some day be successfully used for firing locomotives. As stated by Mr. Wood, it is being successfully used for firing cement kilns and heating furnaces. I looked into this subject to a considerable extent before I began work on my locomotive stoker and found that the difficulties in the way of a successful solution of the problem were so complex and so many that at that time I did not believe it advisable to take it up. That was six years ago, and since that time there have been some improvements in methods of handling powdered coal, but when compared with the entire problem these improvements are very small.

On the other hand, the problem of firing locomotives by means of a stoker has been solved. These machines are in daily and regular service on between four and five hundred locomotives, and are being applied at the rate of from fifty to seventy-five locomotives per month. The development of the stoker has reached the stage where it is possible to apply a machine, run the locomotive out of the shop, attach it to a train, and make a run over a division, the stoker doing a 100 per cent. job the first trip, and the locomotive developing its full capacity. This has been done not only with one machine, but with fifty or sixty of them in succession. The stoker today is just as reliable as the locomotive and can be depended upon to do its work. This machine is today doing everything which it is claimed that powdered fuel will do if it can be developed. This may sound like an exaggerated statement, but there are at least two hundred locomotives in regular, constant service which will, on investigation, prove that this is true.

The statement has been repeatedly made that a stoker-fired locomotive produces smoke. On the other hand it is claimed that oil-fired locomotives do not produce smoke. I have seen oil-fired locomotives producing clouds of smoke which were more dense and far beyond anything I have seen produced by coal-fired locomotives. Of course, the oil-fired locomotive was not being properly handled, and when the stoker is not properly handled, it does produce smoke. When properly handled and applied to a locomotive having a combustion chamber, brick arch and suitable appliances for admitting the proper amount of air to the fire-box, however, it runs practically without smoke.

With hand-fired locomotives there are firemen who hold the opinion that unless black smoke is rolling, the locomotive is not steaming properly. Stoker men have the opposite view and today the majority of stoker firemen, if they see smoke issuing from the stack, immediately know that they are not properly handling the machine and take measures to correct it. This is not a theory, but a fact and it can be seen at a number of different places on a number of different railroads.

It is claimed that powdered fuel will give a better control of the fire than is obtained with hand firing. This is true, but it will give no better control of the fire than is at the present time being given by stoker firing. The stoker can be shut off, which instantly stops any increase in the heat in the firebox. On the other hand, it can be instantly thrown to its full capacity, which will feed more coal than can possibly be required. Adjustment can be made quickly to any stage of coal consumption which may be required by the service being performed by the locomotive. The above results have been accomplished by taking well designed locomotives which are in regular service and attaching stokers to them, but without making any changes in the design of the locomotive. Mr. Wood admits that for the successful handling of powdered fuel the locomotive would have to be entirely redesigned.

The records of the patent office show that more patents have been issued for the burning of powdered fuel than for any other one type of device of this nature, but only a very small number of these patents have ever been developed to a practical use.

Mr. Wood does not mention one of the most serious difficulties in the way of firing locomotives with powdered fuel, and that is the explosive nature\* of the material to be used. All of the information which I have been able to obtain goes to show that this material is fully as explosive as gunpowder and, owing to its very light weight, is even more difficult to handle. It is hardly to be conceived that any one would assume the moral responsibility for placing on the tender of a passenger train eight or ten tons of any material of an explosive nature, and it is difficult to imagine a roundhouse containing 25 or 30 locomotives, each with a tank of explosive, and, in addition thereto, a system for storing and transferring two or three hundred tons a day of a material of this character.

It is, of course, impossible to say what can and what cannot be done, and it may be that some practical plan for doing this can be worked out, but I take the liberty of suggesting that if the large locomotive company referred to by Mr. Wood expects to successfully adapt powdered fuel to the firing of locomotives, it might be wise to add at least one, if not two, cyphers to the sum set aside for that purpose.

CLEMENT F. STREET.

#### FALLACY OF THE EQUATED-REVENUE COST UNIT.

NEW YORK, July 20, 1913.

TO THE EDITOR OF THE RAILWAY AGE GAZETTE:

The article written by "A Student" in the *Age Gazette* for July 11, suggesting the use of a cost or efficiency unit applicable to both passenger and freight services, seems fallacious for the following reasons:

1. The revenue unit cannot be used to determine costs as between passenger and freight for any one road. This is admitted in the article. But the crucial problem in determining any kind of railway costs is the division of the primary accounts between the passenger and freight services. If this cannot be done, it is meaningless to assert that a "unit cost" may be found; for a unit which could not be applied to freight or passenger rates and mileage separately, but only to a combination of the two services, would be as useless to the rate maker as to the railway manager.

2. Even though the object were to make a general comparison between different roads with respect to the efficiency of the roads as a whole, it is difficult to see how such a unit would be any more accurate than the operating ratio. It is well known that the operating ratio, though quite generally used, is merely a general index to the financial condition of a railroad, and cannot be relied on to furnish any test of efficiency. Any statistical unit of this nature is merely a greatest common divisor for a mass of detailed information. It should serve only as an introduction to a closer study of railroad accounts and operations. Any one familiar with railway operations knows the great range of operating and traffic conditions even within an I. C. C. group.

3. This suggests a third criticism, namely, that the unit which "A Student" proposes combines results taken from the group as a whole with those of any one railroad within the group—producing a statistical hybrid of questionable value. The contention that demand and supply operating on a large scale within the group tend to fix a just or even a normal rate, is untrue. If demand and supply operated with freedom in the field of transportation, there would be no occasion for the present demand of the eastern roads for a horizontal increase in freight

rates. Values in transportation are more complicated than in any other field of economic activity, and abnormal conditions are more apt to exist there than elsewhere.

4. The fact that the reciprocals of freight and passenger group-rates are used as a means to place the freight and passenger service on a common basis, can accomplish nothing more than would a mere comparison of total mileage and total revenues for the respective services. It means merely that the figures are placed on a more convenient basis. It does not disclose any facts which are not shown in the basic figures.

5. It is impossible at present to find any one unit which will permit an accurate comparison of two railroads, or two I. C. C. groups, with regard to efficiency or in any other respect. The science of statistics is doubtless in its infancy. In order to determine the cost in transportation it is necessary to analyze both revenues and expenses, so that the constant inter-play of cause and effect between the two may be sufficiently revealed. Many attempts have been made to analyze expenses with reference to the character of the service—principally in connection with rate cases—but this is still in the experimental stage. Railway managers are too busy planning new development to take any serious interest in this problem; and not until the growth of traffic slackens will there be any great practical demand for its solution. On the other hand, a further separation of revenues might be undertaken at once with comparatively little cost. The I. C. C. reports at present contain no adequate analysis of traffic conditions or of the work done by the railways. Until such an analysis is made no complete information in regard to efficiency will be obtainable by the public. And it is more probable that standards of efficiency will not be worked out in a scientific spirit until railway managers become interested in the analysis of operating expenses.

OWEN ELY.

#### RELATIVE VALUE OF SERVICE FOR PASSENGERS AND FREIGHT.

NEW YORK, N. Y., July 15, 1913.

TO THE EDITOR OF THE RAILWAY AGE GAZETTE:

The article by "Student" in your issue of July 11, on passenger and freight expenses, affords an illustration of the tendency of theorists to suppose that the truth is all on one side. As a matter of fact, the truth is a variable and the resultant of many forces whose relative strength is constantly changing. Observation will bear out the general statement that rates of any kind, whether for merchandise or services, are the resultant of three economic forces acting together and represented at any instant by, (1) value of service, (2) cost of service, and (3) ability to pay. These are the three-fold co-ordinates on which the rate curve may be plotted. Legal interference may prevent the natural play of these forces, but where unwisely applied it will be burst by the economic pressure.

When a new article or process is introduced, its rate or price is based largely on the value to the public of the new in comparison with the old way of doing the same thing. If a sufficient number of people to pay for the new process at a rate above its cost cannot be secured, the thing is unprofitable. The number of railroad receiverships is sufficient to show that value of service combined with ability to pay may fall below cost of service, and that cost of service so far from fixing rates is only a base line from which their profit ability is measured. It is equally wrong to go to the other extreme and say that value of service alone determines rates. When value of service and ability to pay push the rate very much above cost, the large traffic and profits excite competition, as in the case of an electric line competing with a steam road, and here the lower cost of the former makes possible the making of a lower rate, with the same profit. This lower rate decreases the value of the service in the eyes of the public and also attracts traffic which is able to pay the lower rate but not the higher. The high rate will then probably be lowered to a point slightly above cost or may be kept below it,

\*Mr. Wood did not mention this in his original article, but covered it quite fully in the *Railway Age Gazette* of July 18, page 83. Mr. Street's letter was written, but not received, before this letter was published.—EDITOR.

as a matter of policy; the steam road expecting to make up for the loss by starving out the electric. What nearly always happens, however, is that the high rate line buys out the low, establishes a monopoly and restores the old rate, gaining added profit from the low cost line.

In regard to passenger and freight rates, it should be borne in mind that freight rates from the shipper's point of view are part of operating cost, and are pro-rated in the price of his goods to his customers, whereas passenger rates from the passenger's point of view are charged to general expenses, either pleasure or business, and cannot be passed on pro-rata. A man will pay 50 per cent. extra to travel from New York to Chicago in eighteen hours, who would not pay 50 per cent. extra to have his milk or bread shipped quickly. In the passenger trip the value of service plays a predominant part, whereas in the freight shipment the prospective sellers of the goods have so adjusted rates at a small margin above cost, that cost itself is the more important factor. Figuring passenger and freight expenses and rates on the same basis, is like trying to mix oil and water.

W. F. TURNBULL.

#### WITH THE AUTHORITY GOES THE RESPONSIBILITY.

WASHINGTON, D. C., July 14, 1913.

TO THE EDITOR OF THE RAILWAY AGE GAZETTE:

The attacks upon the railroads have been so long continued and so persistent that, unconsciously, the odium has fastened itself upon the officers as individuals, until they are actually being deprived of their just voice in the government as tax payers and citizens. Any attempt upon their part to legitimately assert themselves in the politics of the community in which they reside, and in which they are as vitally interested as any other citizen, is almost invariably viewed with suspicion. They have equal rights with other citizens, and, as property owners, are equally interested in checking any tendency toward improper forms of government. These rights include the one of contributing individually to public opinion by criticism of existing conditions which they consider improper. Their criticism, if it can be encouraged, is more than likely to be of a high order, by reason of their training and conservatism due to constant pressure of heavy responsibility. Their criticism would uniformly be based upon calm review of facts, and not theories, and should carry great weight, because of the backbone of argument founded upon solid reason and logic.

The report of the Interstate Commerce Commission upon the recent regrettable accident in the train service of the New York, New Haven & Hartford has now been in the hands of railroad officers for sufficient time to have enabled them to carefully digest the decision and crystallize their opinions. As an individual in the great body of railroad officers, the opinion referred to presents itself to the writer in the following light: Somebody was responsible for the accident. The commission places this responsibility on the management. It gives the reasons basing its decision upon the broad theory that the protection of the lives and safety of the citizens is paramount. This argument can hardly be disputed. It holds that the management did not exhaust every effort toward this protection, by allowing an insufficiently trained engineer to have charge of a high speed passenger train. Let us assume that, not only technically but actually, the charge is true. The commission ignores any and all causes leading up to the alleged failure. It is a matter of common knowledge to anyone having anything to do with railroads, that there are certain conditions now in existence on nearly all railroads which may have entered into this failure, and which may enter into another failure of a like nature in the near future.

The commission with its universal reputation for knowledge of railroad conditions, and its vast means for acquiring information, must surely be acquainted with these conditions. If it is not, it can easily procure a large amount of data for its files

for future reference; if necessary, through the sworn testimony of thousands of railroad officers. It has been pointed out to the commission that the working rule, which led to the improperly trained engineer being in charge of the train, was thrust upon the management of the railroad, under a certain amount of coercion. The commission apparently holds that it is not concerned in such details of the management. Be this as it may, the commission has justly held that the protection of the lives and safety of the citizens is paramount, and it is not doing its full duty if it does not make an honest effort to investigate and closely watch any feature, whatsoever, which may even indirectly jeopardize such protection.

In the final analysis, it is not solely a question of the public being disappointed that the intelligent use, by the commission, of the authority of the highest type of law, resolved itself into high flown language of empty meaning, but it is a question whether the commission itself will not have to share in some of the responsibility through partial justice and one-sided regulation.

SUPERINTENDENT.

#### WHY GIVE PASSES TO EMPLOYEES?

NORFOLK, Va., July 11, 1913.

TO THE EDITOR OF THE RAILWAY AGE GAZETTE:

Referring to the latest demands of railway employees for an increase in wages:

I noticed in the paper the other day that railway employees who were going to the meetings held in connection with the demand for a raise are traveling free of charge on transportation furnished them by the railways. Does it not seem very inconsistent for the railways to furnish transportation to employees who do not use it on business of the company? The public is now very properly debarred from using free transportation, but from personal experience I feel that the class of employees who are extorting these wage increases from the railways are using passes for themselves and families more than any other class of travelers. Everyone can recall instances of employees and their families traveling around in baronial style on free transportation.

I suppose that at first the issuance of passes by the railways to employees was intended to create a friendly feeling and to encourage co-operation between all concerned. If the railways are foolish enough to believe that the great value of transportation which they donate to organized labor in their employ is appreciated, they are laboring under a delusion, which the latest wage settlements must have dispelled.

We are very much concerned in this matter. In case the Interstate Commerce Commission and shippers do agree to a 5 per cent. increase in freight rates, how will it help the situation if this latest wage demand consumes every dollar the railways gain? Until this request for a 5 per cent. increase was made, they probably had no idea this latest raise was contemplated by their trainmen, but under the circumstances, we think that railway employees, who are engaged in creating a very critical industrial situation, should receive no more favors from their employers as regards transportation than does the general public.

Railway employees know full well that a strike would result in government operation until a settlement was reached and, perhaps, would encourage the advocates of general public ownership and other socialistic doctrines.

If the railway employees who are already receiving more than they earn would stop and consider that the employees of state operated railways elsewhere receive nothing like the wages paid in the United States under private operation, they would desist from attempts to bring on a critical situation.

Government employees, such as railway mail clerks, performing the most arduous duties, are now compelled to receive less wages than paid by railways, with less chance for promotion.

E. L. MCCOLVIN,

Business Manager, Chamber of Commerce of Norfolk, Va.

## "THE SIGNIFICANCE OF THE STATE RATE CASE DECISIONS."

WASHINGTON, D. C., July 10, 1913.

TO THE EDITOR OF THE RAILWAY AGE GAZETTE:

Will you permit the suggestion that perhaps the law, as disclosed by the Supreme Court, is not quite so adverse to investors in railway property as might be assumed from the summary of recent decisions in the editorial, "The Significance of the State Rate Case Decisions," which appeared in your issue for June 27, 1913. I refer, particularly, to the following paragraph:

"In all the state rate cases decided last week and the week before it (the Supreme Court) apparently holds that if a certain schedule of rates is confiscatory as to one of two competing railways and not confiscatory as to another, the railway as to which they are not confiscatory must accept them. It gives the weak railway Hobson's choice saying, in effect. 'You may take either confiscatory or non-confiscatory rates. But in any event your competitor must make rates which as to you are confiscatory, and if you are not bankrupted by making the confiscatory rates you will be bankrupted by losing business because you do not meet them.' The principle laid down is a principle of confiscation by indirection as distinguished from a principle of confiscation by direction. The conclusion of the Supreme Court is in substance, that a given schedule of rates may be unreasonable as to one road, and reasonable as to another operating in the same territory and handling the same kind of traffic. Only the judicial mind can tell how a given schedule of rates may at the same moment be both reasonable and unreasonable. This is law because the Supreme Court says so. But it is neither economics nor business. When Lord Eldon said that the law was common sense he did not foresee the decision in the Minnesota rate case."

Whether the foregoing (a) literally defines a principle of law sanctioned by the decisions, or (b) merely describes the effect of the decisions as applied to the particular pleadings and proofs before the court, is of the greatest importance. If the Supreme Court has, indeed, held that, regardless of all facts as to the economic utility of the several lines, the rates of independent and competing carriers serving the same regions may be separately examined and those of any of them subjected to legislative reductions without regard to the effect of these reductions upon their less favorably situated competitors, then, nine-tenths of the railway mileage of the United States is already potentially bankrupt. If such is the case the legislature can make the conditions of the best located and most efficiently managed competitor the standard of rates to which every other must submit, the constitutional safeguards against confiscation endow the judiciary with no practically available power to protect at least nine-tenths of the aggregate mileage, and, as to that portion, all arguments for the right to receive justly compensatory rates must be addressed to the legislature and are entitled to consideration by the legislature only. If such is the law, then your criticisms of the state of the law are not too severe.

I venture, however, to suggest that perhaps the decisions just rendered are not authority for this devastating conclusion. It is true that your language accurately describes the effect of the decision in the Minnesota case upon the Minneapolis & St. Louis Railway, which, of course, will be compelled to accept the rates forced upon its more fortunate competitors, although those rates have been judicially found to be confiscatory as to itself. And probably the conclusion must be the same as to the effect of the exceptions to the general conclusions in other cases. But the Supreme Court could not have been expected to go outside of the pleadings and proofs of the cases before it, or to invoke for the protection of any carrier principles of law not asserted in its behalf and not capable of application save in the light of facts not disclosed by the record.

In deciding the Minnesota case, the Supreme Court, speaking by Mr. Justice Hughes, quoted, with approval from the decision in *Smyth v. Ames* (169 U. S. 466), in part, as follows:

"What the company is entitled to ask is a fair return upon the value of that which it employs for the public convenience. On the other hand, what the public is entitled to demand is that no more be exacted from it for the use of a public highway than the services rendered by it are reasonably worth."

And, in the same decision, the court, in terms that will often hereafter be cited as the sanction of private rights even when qualified by a public interest in the use of such private rights, said:

"The property of the railroad corporation has been devoted to a public use. There is always the obligation springing from the nature of the business in which it is engaged—which private exigency may not be permitted to ignore—that there shall not be an exorbitant charge for the service rendered. But the state has not seen fit to undertake the service itself; and the private property embarked in it is not placed at the mercy of legislative caprice. It rests secure under the constitutional protection which extends not merely to the title but to the right to receive just compensation for the service given to the public."

An examination of the Minnesota case, as presented to the Supreme Court, shows, however, that after asserting that the state-made rates were unlawful as an interference with interstate commerce, a contention that was not sustained, each of the carriers separately relied upon such showing of confiscation as could be made by the segregation of its property, expenses and receipts in Minnesota from its general business. This portion of the attack upon the state-made rates was thus made to rest entirely upon comparisons between the valuation of the property of each separate carrier and its separate balance of receipts over expenses. There was no suggestion that either the Great Northern or the Northern Pacific was deprived of its property in the use of its facilities in that the public, acting through the state legislature, had demanded that services be rendered for less than they were reasonably worth (*Smyth v. Ames, supra*) or that the just compensation or fair rate of return on the fair value of the property used in the public service, to which both are entitled, might be measured by reference to the lowest rates that would not be confiscatory of the property of another carrier, performing useful and necessary services of the same character in the same region. This was an omission which, in view of the uncertainties of the law prior to the recent decisions, is not subject to criticism, but it is one that may have deprived the court of opportunity to protect these carriers in the enjoyment of the legitimate rewards of their superior efficiency and practically of the power to protect the less fortunate Minneapolis & St. Louis from the dangers of its competitive situation.

Without attempting the exhaustive examination of authorities necessary fully to support my contention, I venture the suggestion that whenever a carrier, however, efficient by reason of its location or superior management, can show, first, that a rate or schedule of rates prescribed under legislative authority is so low as to deprive any competitor of its right to a fair return upon the fair value of its property, and, second, that the services of such competitor are actually necessary if the public is to be adequately supplied with transportation, then, in such case, the rate or schedule so prescribed is below the lawful measure of "what the services rendered by it are reasonably worth," and whatever return the more fortunate and efficient carrier may be able to obtain from a rate or schedule which would afford a fair return to such competitor is no more than the fair return to which the circumstances entitle the more efficient line. If so, any compulsory reduction that if applied to the weaker line would deprive it of its right to a fair return deprives the more efficient carrier, as well, of a part of its just compensation and is *pro tanto* a confiscation of its right in the use of its own property. I am unable to find anything actually inconsistent with this view in the recent decisions.

H. T. NEWCOMB,

Member of the District of Columbia Bar.

# THE QUESTION OF INCREASED FREIGHT RATES.

Agricultural Expert Argues an Advance Would Help Farmers, and Outlines Plan for Investigating Entire Subject.

By A. B. HULIT,

Managing Director, American Agricultural Association.

When the American bankers were supposed to have taken unofficial action calculated to discourage the creation and sale of so many farm securities, many of the officials of the southern and western states saw that in this act was the beginning of a general slowing down in all kinds of development, and that if the market for farm securities was to be curtailed, a very great hardship would be imposed upon the farmers who were endeavoring to build homes in the newer sections.

So great was the uneasiness caused by this action that it became one of the reasons why the immigration officials of some of the states decided to hold a conference in Chicago for the purpose, among other things, of trying to find out why the bankers had taken such action and, if possible, to work out some plan which would counteract these influences. At this conference a permanent organization of state immigration officials was perfected under the name of the National Association of State Immigration Officials, and I was elected commissioner-general of that organization, and Chicago was designated as our permanent headquarters.

It became part of my duty to investigate the reasons why the bankers had taken such action as they had against farm mortgages, with the result that I found that while there had not been any real official action taken, the word had been passed down the line to discourage the sale of farm securities, and that as a rule the bankers were doing so. I soon discovered the reasons why this was, which were as follows:

In the development of so much cheap land in the south and west, which was being placed on the market at comparatively high prices, the sellers in making sales usually took a first mortgage on the land as part payment. These mortgages bore from 6 to 8 per cent. interest and were becoming very popular with the investors, so much so that immense quantities of money that had been invested in other securities or was on time deposit in the banks was being diverted from the ordinary commercial channels.

The bankers argued that if we continued our prosperity, if the crops were good and prices remained high, these notes could be paid; but, they contended, if the crops should fail and prices become low, these notes could not be paid, and some of them advanced the argument that whether or not crop conditions remained normal, with the disposition of the people in the various states to pass laws which affected the railroads, cutting down their revenue and placing so many burdens upon them, sooner or later the railroads would begin to feel the effect and those who were holding railroad securities would become uneasy, knowing that the railroads could not pay dividends under the rapidly developing new conditions; that the railroads' credit would be lost, and that sooner or later the roads would have to withdraw their support from all development enterprises. These bankers pointed out that the railroads had been and were the real inspiration behind everything that contributed to the development of the western and southern states. I was told three years ago that the railroads could not hold up under the loads placed upon them, and that owing to the enormous amount of money invested in them, which was represented very largely by their stocks and bonds, which were held by so many people, the agitation against them laid the danger of a financial panic that would come within two years. The bankers I consulted, said, "When that panic comes it will close down many of our banks—those which for any reason have become directly or indirectly owners of farm securities or interested in development enterprises. It will close many of our factories, restricting the output of all, causing a

general slowing down all along the lines. Railroad earnings will fall off; prices of farm products will drop and money will become scarce." A few of these bankers pointed out the fact, that in the building of the Panama Canal lay a danger to the railroads and indirectly to the people of the West that must be considered.

When at first these arguments were advanced, I, like a good many of our optimistic western men, could not see things that way, and I accused the bankers of entertaining narrow and selfish motives and so reported to our members. My own faith in the West and its future was and is yet unlimited. I simply would not allow myself to foresee this danger. But in the light of the experience of these last three years, I am now compelled to admit that I was wrong and that the bankers understood these problems far better than I did. They were right then, and are now, and I want to say that in the action they are presumed to have taken lies our safety today. They are reasonably well prepared to meet any conditions that may arise. But the prospects of the panic they predicted are so evident that I am now forced to further admit that the bankers fully understood the situation. In discussing the matter with some of them recently, they say, "Yes, we are threatened with a panic now, and it is a surprise to us that it did not come sooner and with more velocity. The facts are, we have had such good crops which sold for such high prices that the farmers are still prosperous, as are our manufacturers and general business men."

In my analysis of the present financial situation, I cannot find any particular class of men who have cause for complaint but the railroad men and their security holders, and they are certainly in an unsatisfactory frame of mind. I have been studying this phase of the situation, with the result that I have found that when the federal government created the Interstate Commerce Commission and gave it the power to fix freight rates and the various states followed suit, the lowering of rates was carried on in a wholesale way and to the danger point. But serious as this was and still remains, it does not represent all of the trouble; for with the lowering of freight rates the cost of living began to soar and the men began to ask for and in many cases were granted raises in their wages. Raw materials and new equipment began to rise in price. The new laws compelled the railroads to shorten the hours of their men and to adopt methods in their operations which added to their costs. Stop and make a little calculation on what it will cost the railroads to replace their wooden passenger and express cars with new ones of steel. A big burden of itself; but this is not all. There are an endless number of items that represent great expense to the railroads. The cities are demanding new terminals, elevated and electrified tracks. The great floods and other great calamities like the San Francisco fire and the Omaha cyclone have all added to the burdens of the railroads. The foreign wars have affected the money market; then the approaching completion of the Panama Canal, which the investors believe will be the means of diverting large quantities of transcontinental freight from the railroads that need it, will affect the earnings of these roads.

I find that while the railroads are now enjoying a fair amount of business, their cost of operation is advancing at an alarming rate. This is apparent to every one, and especially to the investors. I find that it is almost impossible to sell railroad securities at a price the roads can afford to accept. Now, here is the problem: if the roads cannot earn the money with which to operate, buy new equipment and pay dividends, they must bor-

row it on deflated security, which they cannot do under the present circumstances. I only regret that I cannot here go into all of the minute details of the entire situation and prove that whether they want to or not, they cannot meet the demands placed upon them. It is a physical impossibility; and it is my private opinion that if we are able to temporarily prevent a financial panic and if some relief is not given the railroads at once, the basic cause of the trouble will remain and if, perchance, we should have a poor crop next year or a good crop and poor prices, we will see a panic that will paralyze all industry before eighteen months are over.

It is a pretty generally conceded fact that the railroads and their influence are the life's blood of our industrial activity, and I contend that if we stagnate the railway industry, inactivity will follow. I believe the time has come when the American people should discard the muck-raker and the socialist agitator and assume full control of the situation; that the public should become conversant with the facts; and if I am right in concluding that in the railroads' situation we have found the real cause of the threatened difficulty, and that, simmered down to a fine point, the whole trouble lies in the fact that the railroads are unable, with their present earnings, to meet the demands, then we can without serious injury to ourselves supply the remedy by simply granting a temporary raise in the freight rates of 10 per cent. for a period of ten years or long enough to enable the roads to meet the conditions the public has made.

I hold that in principle the public was and is right in demanding federal regulation of the rate-making power of these roads and is right in requiring the railroads properly to equip their trains and to run them so as to give better service. But I also contend that in doing these things we should use ordinary business precaution; for, after all, the railroads are legitimate enterprises of vast importance to the public as a whole, and what affects them affects the public. I believe that a careful, dispassionate investigation of the uncolored facts will show to any reasonable man that we have placed too heavy a burden on these roads at one time and under conditions which could not be foreseen when we acted.

A large part of the legislation reducing freight and passenger rates was passed in the spring of 1907. Who foresaw then that a little later in that year the railway employees would demand and secure by arbitration large advances in their wages? Who foresaw that a panic would come in October, 1907, as a result of which the earnings of the railways would be reduced by \$300,000,000 in the calendar year 1908 as compared with the calendar year 1907? Who foresaw that the net earnings per mile in both 1908 and 1909 would be less than they were in 1907, and that while they would increase in 1910, they would again decline heavily in 1911 and 1912? Who foresaw that in every year since 1907 the railway employees would continue to make further demands for increases in wages, every one of which arbitration boards would grant, until, while the railways in their efforts to economize would employ 2,300 men less in 1911 than in 1907, they would be obliged to pay to this smaller number of employees almost \$140,000,000 more in wages in 1911 than they had to pay the large number of employees in 1907? And since 1911 the roads have had to make further increases in wages amounting to several millions, and the conductors and trainmen in Eastern territory are now demanding still further increases which, it is estimated, will amount to \$17,000,000 a year. Not only have the railways been obliged to make these large increases in the wages of their employees, but they have been compelled to make numerous increased expenditures for other purposes, and they are confronted with demands for still further increases in expenditures. In compliance with the safety appliances law passed in 1910 they are now engaged in spending about \$60,000,000 for improvements in safety appliances. The various states have passed numerous laws requiring them to increase the number of men employed in train crews, and it is estimated that train crew legislation already passed is costing them \$5,000,000 a year and that if similar legislation were applied throughout the country, as is proposed, the total cost of it

would be from \$13,000,000 to \$20,000,000 a year. It is proposed to require them to install block signals on all of their lines, and if this is done it will involve an additional investment of over \$260,000,000. It is proposed to require them to widen clearances between their tracks and overhead and lateral objects, and it is estimated that if the proposed legislation were passed it would involve an expenditure of \$444,000,000. Many communities are demanding track elevation, and how much this will cost is indicated by the fact that track elevation work now being done in Chicago alone already has cost \$70,000,000 and will before it is done cost \$150,000,000. It is proposed to require the railways to replace all of their wooden passenger train equipment with steel equipment, and this, it is estimated, would cost \$633,000,000. I repeat, who foresaw all these developments when the campaign for lower freight and passenger rates was begun some years ago? And can it reasonably be assumed that the railways can go on forever bearing up under these increasing expenses and demands for increased investment without any increases in their rates?

I have faith in the future. The people are honest and courageous, and in the spirit of fairness they will see to it that wrongs are righted when the time comes. There is an underlying and sometimes unappreciated disposition on the part of the men behind the plows to see the game of life played fairly. I have faith in these men whom I am now trying to serve as best I know how, in my official capacity, both as the commissioner-general of the National Association of State Immigration Officials and as managing director of the American Agricultural Association.

I fully appreciate the fact that I am assuming toward the railroads a new and what will become for the present an unpopular position. But I am convinced that I am right, and that it is my solemn duty to throw out the warning to our members and to those who are not but whom we, as organization workers, are trying to serve.

I am now going to review this situation from the standpoint of the farmer, manufacturer and laborer, and especially those who are engaged in railroad work as employees.

To begin with, I assume that the farmers are the most directly interested in this subject because they are, as a rule, large patrons of the railroads, and their success as land owners depends very largely upon their ability to produce and then market their products; and the value of their lands is increased or diminished just as they are able to operate at a profit. I also assume that the present conditions, insofar as the farmers are concerned, are satisfactory; but that, if by any chance the factories and railroads begin to lay off their men, this would affect the price of their commodities as well as their lands. This, the farmers will concede, is sound logic. Now, the only question is, will we see a slowing down? If so, what will be the cause? What is the remedy? If I am right in this argument, and the trouble emanates from the railroad situation and is based upon the fundamental fact that the railroads are not able, with the rates they now have, to meet the conditions, and that the granting of a 10 per cent. increase in these rates for ten years will avert the trouble, then we have the cause and are shown very plainly the remedy, and it is our duty to ourselves to apply it.

The next question is, can the farmers afford to apply the remedy? Let us see, taking one illustration to prove the point. We will assume that a certain town does \$100,000 a year business with the railroads and that the granting of a 10 per cent. raise in rates would mean that the people in and about that town would be compelled to pay \$10,000 a year more in freight. Let us go on and assume that this \$100,000 of freight comes directly and indirectly from 100,000 acres of land about that town; land worth under normal conditions \$60 per acre, and which is gradually rising in price. But if we had a panic and these farmers began to lose money, and this land should depreciate \$10 per acre immediately, it would become unsalable and it would be difficult for the farmers to borrow money or to repay it. Assuming this condition prevailing, it would be a

very easy matter for practical farmers to imagine that their land would depreciate \$10 per acre. If so, the total loss to the men who own this 100,000 acres of land around this town would be \$1,000,000, or enough to have paid the \$10,000 per year in increased freight rates for one hundred years.

Now, as a matter of good business, if it can be shown that in the granting of this 10 per cent. increase in rates the danger of a panic emanating from this source can be averted, would it not be good judgment to grant it, as a mere precautionary measure, a sort of insurance, against adversity?

Now, this is not an isolated case chosen to illustrate the point, but it is typical of the conditions found about every town, large or small, especially in the south and west.

Now let us take the case of a manufacturer who we will say has \$1,000,000 invested and is running at full capacity and under fairly favorable conditions, and that, as is the case with most manufacturers, he is a heavy borrower at the banks and has out long time notes or bonds which draw a fixed income, whether it is earned or not, and that this same manufacturer has sold immense quantities of his products for which he holds unpaid notes or open accounts that are good when times are normal; and let us assume that financial conditions have been developed which have brought a panic and he is compelled to lay off one-half of his employees and cut down his output one-half; his fixed charges remain about the same. What would be the condition of this manufacturer under these circumstances? If the granting of a raise of 10 per cent. in freight rates will possibly remove this danger, had he not better grant it? Those who have been seen and who have investigated it are today favoring such a raise.

Then we must consider the laborers. They are having it hard enough now with the present wage scale and the high cost of living to make both ends meet. They look ahead and see the day when, with approaching old age, they will not have been able to lay aside anything. As a rule, they do not have a surplus now, but suppose we had a period of three or four years of hard times which necessitated from 25 to 50 per cent. of them being thrown out of employment with no means of support for themselves and families. God grant that it will not come; but do not the facts indicate that it will? Do not the arguments at hand go to prove that we are even now face to face with a panic? I am not going to take sides here with or against these men in their struggle for more wages; that is their business; but I am going to suggest here that the laboring men lay aside their prejudices and here and now make an investigation of these facts which I believe are so serious as to demand their attention, as they certainly do demand it of the farmers and business men in general.

I also appreciate the fact that with our people so widely scattered all over the country and all so busy with their own affairs, it will prove to be an impossibility for each one to make an individual investigation of the entire situation, even if each could be aroused to the personal necessity for doing it. Then the time is too short; so I have suggested the idea of having the American Agricultural Association assume the responsibility of acting for the public in this important matter, on the theory that this organization is composed of all classes of men whose reputation is a sufficient guarantee that their findings will be honest and fair. I have opposed the idea of having this investigation made by officials in power who are or might be influenced by their political alliances.

I have, therefore, asked the president of the American Agricultural Association, R. S. Vessey, former governor of South Dakota, to create a special committee of five well known men to act as a body for the purpose of immediately setting on foot an exhaustive, painstaking investigation; this committee to be composed of business men representing each political party and who are known to be fair minded, capable men. Mr. Vessey has agreed to appoint this committee. I have suggested that it assemble as soon as possible, and that it invite the railroads to come in and make a showing of their case and also invite the farmers, business men and the laboring classes to appear before it in

the hope that it will get to the bottom of the whole trouble and that its report will be so fair and honest that it will be accepted as authority on the subject. It is a great work for mankind at a time when it appears to be needed. I believe the public will appreciate this work and that, in conducting it along this line, we will be able to find the facts, and if we do and they are given wide circulation as such, without being made to meet the views of some man or group of men that cannot see except from their own selfish viewpoint, much good will result. In any event no harm can be done.

## FIGHTING THE BOLL WEEVIL EAST OF THE MISSISSIPPI.

President Finley, of the Southern Railway, speaking recently of conditions in the territory east of the Mississippi river into which the Mexican cotton boll weevil has spread, said:

"The boll weevil has appeared in cotton fields along the lines of the Southern Railway and its associated companies in Mississippi and Western Alabama. With a view to obtaining first-hand information as to conditions, I have had one of my assistants visit the infested territory in company with the manager of our department of farm improvement work, who is giving his personal attention to directing the efforts we are making to aid in controlling the weevil.

"Generally speaking, the weevil is present in much of the territory west of a line from Shelby county, Tenn., running diagonally across the states of Mississippi and Alabama to the southeast corner of Georgia. Probably owing to the overflow followed by cold weather, the weevil has been found in relatively few localities in that part of the Mississippi delta traversed by our lines.

"At every point visited in the infested territory a determined and intelligent fight is being made against the weevil. The farmers are being aided and advised in this by the state agricultural commissioners, the agents of the United States department of agriculture, and by our department of farm improvement work. This fight was begun as soon as the weevils which survived the winter began to appear in the fields. While the cotton was small it was possible to find and destroy large numbers of the weevils. With the growth of the plant it has become increasingly difficult to find the insects and the fight is now being carried on by gathering and burning the squares in which the female weevil has deposited eggs so as to reduce the second generation to a minimum. These squares are easily found, as, soon after an egg has been laid, the square flares and turns yellow, later falling to the ground. The object of this is to keep down the number of weevils maturing during the fruiting season. It is important that, at the same time, the crop shall be pushed by rapid and shallow cultivation.

"I am advised that it is the opinion of men familiar with the weevil that these methods of control are proving fully as effective in Alabama and Mississippi as they have been west of the Mississippi river, where, in many localities, more cotton is grown with the weevil than before its appearance. Present indications are that the destruction of cotton by the boll weevil will not be disastrous in any locality along our lines; that where the advice of the government agents and of our department of farm improvement work is followed good crops will be made, and that, where farmers are doing the best work, production will be fairly up to normal. Cotton acreage has been reduced to some extent, the acreage in corn and other crops being increased.

"It is gratifying to know that the appearance of the weevil at points on our lines has not brought about the conditions of panic that followed its spread into some other localities. I believe that some credit for this may be taken by the managements of the Southern Railway for having inaugurated the work of advising farmers how to deal with the weevil in advance of its appearance."

# EXTENSIVE IMPROVEMENTS ON THE L. & N.

Interesting Features of the Bridge, Tunnel and Grading Work Now Under Way Between Nashville and Birmingham.

The Louisville & Nashville is now carrying out one of the most extensive programs of improvement work in the country. This work extends over more than 300 miles of line and a large proportion of it is heavy. There are at present two distinct projects under way. The first is on the main line between Madison, Tenn., about nine miles north of Nashville, and Birmingham, Ala., where a second track is being built, the line revised and grades reduced. The second is between Paris, Ky., and Jackson, where the old line is being improved as to grade and line, and about 30 miles of new line is being built.

joins the main stem from Cincinnati just north of Nashville and the numerous Alabama lines all join the main line at or south of Boyles, three miles north of Birmingham, resulting in the concentration of a heavy traffic on this 200-mile section between Nashville and Birmingham. The undertaking of this important improvement work is easily justified by the present traffic on the L. & N., the average density of which has increased over 30 per cent. in the last decade. Since the increase in traffic on the branch lines is relatively slow the increase on the main line, and particularly the Nashville to Birmingham section, must have been considerably greater than this average. The average total number of train movements per day over this portion of the line in the fiscal year 1910-11 was 34. In the last half of 1911, when studies for the present improvement were being made, the average number of revenue trains per day between Birmingham and Decatur was 37.7. Local transportation

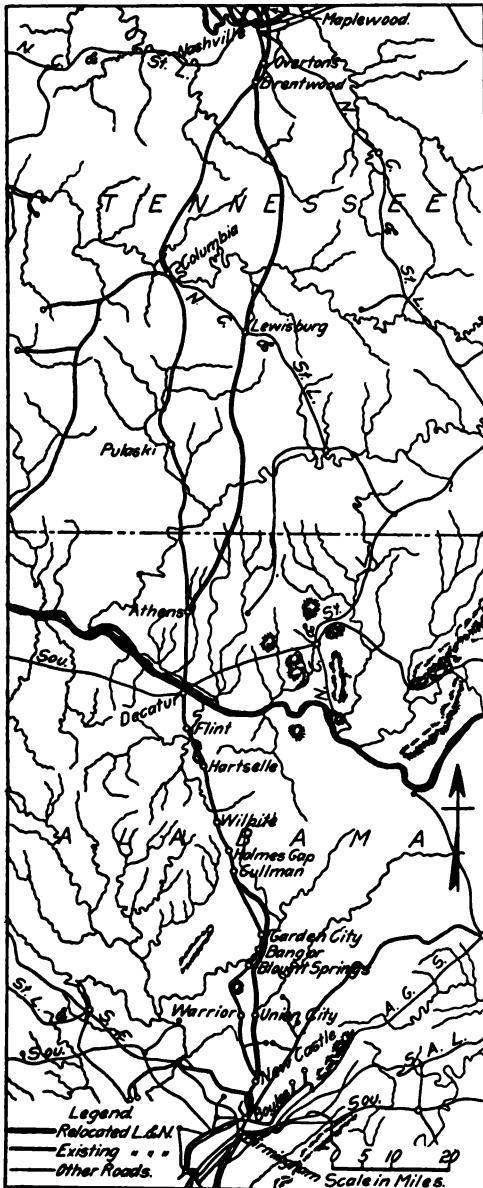

Map of Portion of the Main Line of the L. & N., Showing Revisions Between Nashville and Birmingham.

The present article covers the main line work; the Paris-Jackson section will be described in a later issue.

## OPERATION OF PRESENT LINE.

The line between Madison and Birmingham is the logical place to begin heavy improvement work on the Louisville & Nashville system since the line from St. Louis and Evansville



Cumberland River Bridge in an Early Stage of Erection.

officers are confident that this figure was greatly increased during 1912, although no record is available. In March, 1913, there was an average of 64 trains per day, although this number included some work trains.

The train movements include six through passenger and from two to eight local passenger trains. The freight handled on this district is mixed in class, and while the products of mines furnish more than half of the tonnage handled south of Decatur, the tonnage is fairly evenly divided between the products of mines, agriculture, forests, manufacturers and merchandise on the line north of Decatur. This division of traffic, of course, does not produce a preponderance either of schedule or drag freight. The north and southbound tonnage is very nearly balanced. The old ruling grade between Nashville and Birmingham was 1.25 per cent. in both directions, and the tonnage rating for slow freight was 800 tons, using 4-6-0 freight





Pier 2 is supported on 78 reinforced concrete piles 14 in. square at the butt, 9 in. square at the point and 35 ft. long. Wooden driving blocks were used over the piles, as previous experience had shown wood to be the best cushion obtainable. To still further protect the head of the pile from battering, two cement sacks filled with shavings or coarse sawdust were placed in the hood holding the driving block. As considerable heat is produced by the blows of the driver it was found necessary to wet these sacks to prevent their burning or packing solidly.

A series of tests was made during the early stages of the foundation work to determine the possibility of forming concrete in the sand and gravel bar under the pier footings by injecting a thin grout through pipes driven down in the bar. These tests showed that concrete could be so formed but in general it was not of a satisfactory character, due partly to difficulties in placing the grout, which were afterwards overcome, and partly to dirt in the gravel which caused a poor bond in the resulting concrete.

The masonry was placed from two stationary mixer plants, one on each shore, and a third mixer which was moved around as needed. The south side plant was located on the side hill adjacent to pier 8. The cement house was placed above the mixer, but below the side track of the Tennessee Central so that the cement could be handled by gravity. A good limestone quarry was opened about 800 ft. east of the bridge site on the south side of the river and a crusher plant was installed to furnish crushed rock and pulverized screenings for the concrete aggregate. This material was carried to the mixer plant on the south side in side dump cars which were divided into compartments holding the proper amount for one batch of the one yard mixer. These cars were handled by mules on a track running

temporary yard along the new track south of the bridge. The total tonnage was about 3,700 tons. The contractor used one 25-ton locomotive crane and one 100-ton derrick car with an 84 ft. boom for erection, no member of the truss spans being heavier than the girder spans in the approach trestle. The viaduct was erected by the derrick car, working out on the structure as it was erected. The truss spans were placed on falsework. As the third span is the only one over the water at low stages of the river, it was possible by watching for opportune times, to erect all the spans on falsework.

The contract for the substructure and the erection of the superstructure was handled by the Foster, Creighton, Gould Company, Nashville, Tenn., and at the present rate of progress will be finished well within the contract time. The substructure was completed in about one-half the contract time.

RODNOR YARD.

A new yard which will have an ultimate capacity of 4,700 cars is being built south of the river and just north of the junction of the new line with the old at Overtons. It will have two humps for classification of northbound and southbound traffic, and will probably be the largest hump yard in the South. The principal yard capacities for present construction and future development are as follows:

Name of yard.	Present capacity.	Total development.
Northbound receiving .....	471	846
Northbound classification .....	622	757
Northbound advance .....	541	717
Southbound receiving .....	477	630
Southbound classification .....	446	566
Southbound advance .....	600	900
Repair yard .....	168	303
Total .....	3,325	4,719

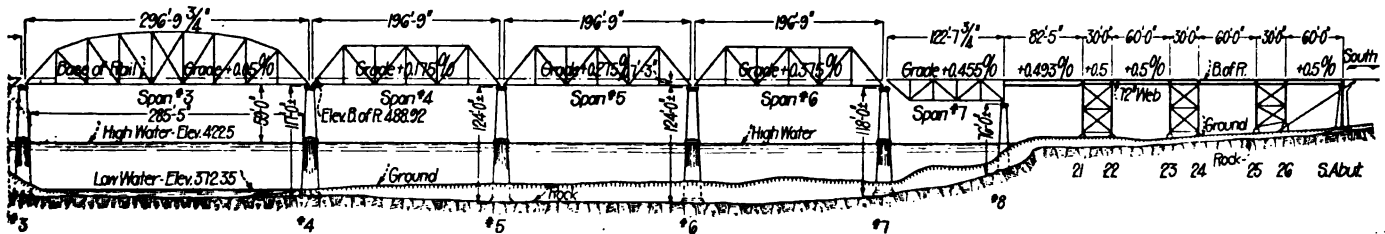

Elevation of Cumberland River Bridge and Approaches (Continued).

over the mixer so that the material could be dropped directly into the hopper. The concrete was dumped into tram cars operated by a cable and running on a trestle alongside the piers. Elevators at each pier raised the concrete to the necessary height. Pier 8 and the adjacent four pedestals were placed by the same derrick which had been installed to unload form lumber and other material from cars on the siding. The 1/4 yard portable mixer was used to place the south abutment and the remaining pedestals. It was also used to push the work on pier 4.

The mixer plant on the north bank was located between piers 2 and 3, the cement house and storage bins being located over the mixer. Cement was transferred across the river on barges and the stone and screenings were brought from the quarry in barges which were loaded in a small slough about 400 ft. from the crusher plant. A gasolene boat was used to tow these barges. The stone and screenings were transferred from the barges to the storage bins by a derrick and clam shell bucket, and the mixer was charged through a hopper graduated to show the correct proportion for a batch. The mixer discharged into the side dump cars operating on a track laid on the center line of the bridge. The north abutment was placed first, a derrick placing the concrete in the forms. The elevation of the track was high enough to allow the concrete to be dumped directly into the pedestal forms and the track was shortened as each pair of pedestals was placed. Elevators were used for placing the concrete in the piers.

The superstructure was erected continuously from the south end, steel being brought in over the new line and stored in a

In addition to these main yards there are stock pens, icing tracks and platforms, as well as all necessary engine leads and service tracks. The yard tracks are 13 ft. center to center and the ladder frogs are No. 8. Main line frogs are No. 9 1/2. The yard is almost 2.5 miles long and will contain 40 miles of tracks in the present development. This construction will require the handling of 905,000 yds. of excavation and 1,330,000 yds. of fill. There are four shovels at work on the site now and two more will be added to push this work as much as possible. The plan is to complete a single track fill for the entire length of the yard at the adopted grade in order to handle material for the buildings and other incidental work. Most of the excavation is in solid blue limestone.

A complete engine terminal is included in the plan, the roundhouse to have 30 stalls in a 60-stall circle. This house will be located on a fill from 20 to 35 ft. deep, necessitating a special design for the footings. Reinforced concrete columns and beams will support the walls and pits, these footings to be placed before the fill is made. After the fill is complete around the footings, the walls and roof will be built. The walls will be of brick, the roof trusses of wood in the roundhouse proper and of steel in the machine shop; the smoke jacks will be 18 in. in diameter, and of asbestos, and the windows will be provided with steel sash. There will be a 90 ft. turntable, and a machine shop and boiler washing plant in connection with the roundhouse. The coaling station will have a capacity of 100 tons. An open car repair shed of steel will be provided in the car repair yard. It will be 60 ft. wide x 200 ft. long with open



Panorama of Cumberland River Bridge with One Truss Span Erected and False Work Being Placed for the Second.

sides and a monitor deck in which steel sash will be placed. The roof will be covered with corrugated galvanized iron. This shed will cover three tracks and will make possible repairs in bad weather. Near the repair shed will be a brick and

pumps. Other buildings in the yard include a 50 ft. x 50 ft. brick store and office building, two car inspectors' offices, three yard offices, an engineers' wash and locker room and numerous toilets.

From Overtons to Brentwood, about three miles, the revision parallels the existing line and there is little work of interest. The summit cut at Brentwood with a new grade about 45 ft. below the existing track, contains about 300,000 yds. of solid

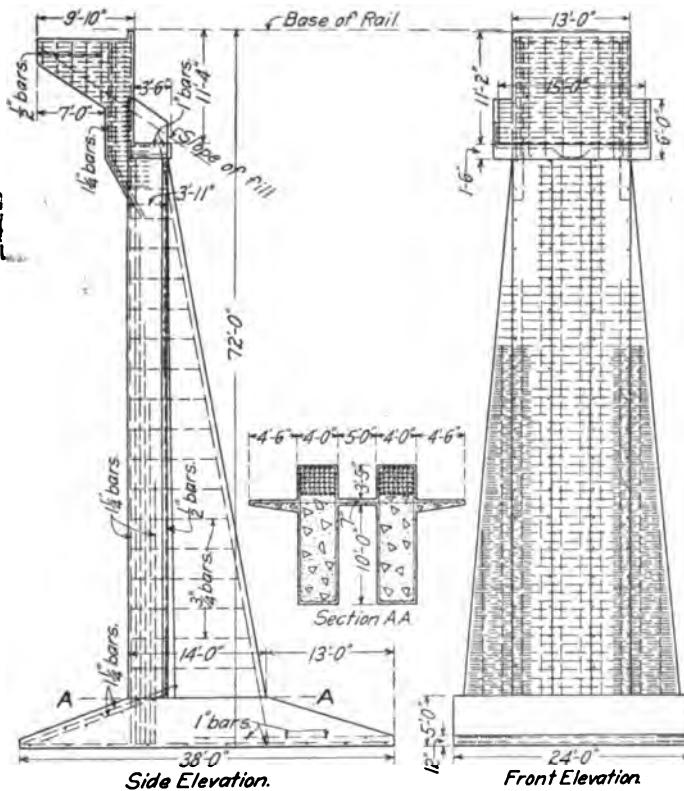

Details of Reinforced Concrete Abutment for Cumberland River Bridge.

frame building, 60 ft. x 200 ft., used for a tinshop and material storehouse. There will be a two-story oil storage building, 40 ft. x 80 ft., of brick and reinforced concrete construction. It will be equipped with ten oil storage tanks and mechanical



Reinforcement and Contractors' Plant for One of the Cullman Viaducts.

rock. South of Brentwood the new line leaves the old, running east of south and continuing on an entirely new location until it strikes the old line again at Athens, 98 miles south. This new line is as much as 17 miles from the old in some places and involves moderately heavy work. There are two tunnels, one of which is on a six-mile pusher grade of 0.9 per cent. The only town of any size on this new location is Lewisburg, which has a population of about 2,000.

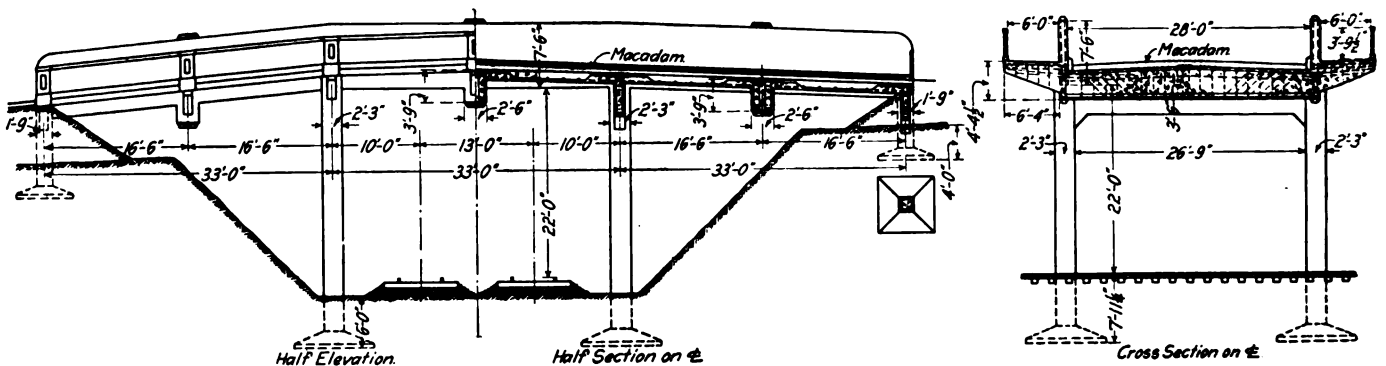

Details of Concrete Viaduct at Cullman, Ala.

COMPANY WORK.

The 12.5 mile section between Athens and Decatur is being handled by company forces. This work consists of a revision of line and grade, most of which is closely adjacent to the operated line and involves some heavy work, complicated by



Cullman Cut Showing Via-ducts. A Typical Piece of Company Work.

poor material and swampy ground. Bids for this work were received from a number of contractors, but as the prices named seemed high, it was decided to give company work a thorough trial and the purchase of \$85,000 worth of equipment was accordingly authorized. The equipment includes an Atlantic

contract price and it is probable that before the completion of the work the entire cost of the equipment may be saved. Very careful records are being kept of every item of cost to enable the engineer in charge to carry on the work most efficiently and some excellent results are being secured. Last October, which was the record month for the shovel outfit, 55,616 yds. were loaded in 26 days working one 11 hour shift. This is an average per day of 2,139 yds., and on the best day 4,319 yds. were loaded. The material handled was principally clay, some of which is flinty and almost as hard as loose rock. The maximum percentage of loose rock handled in any one month was nearly 50 per cent., although in most months it has been less than 10 per cent.

The equipment in use was specially selected for this work.

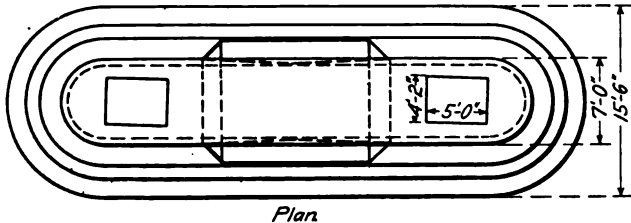

Plan

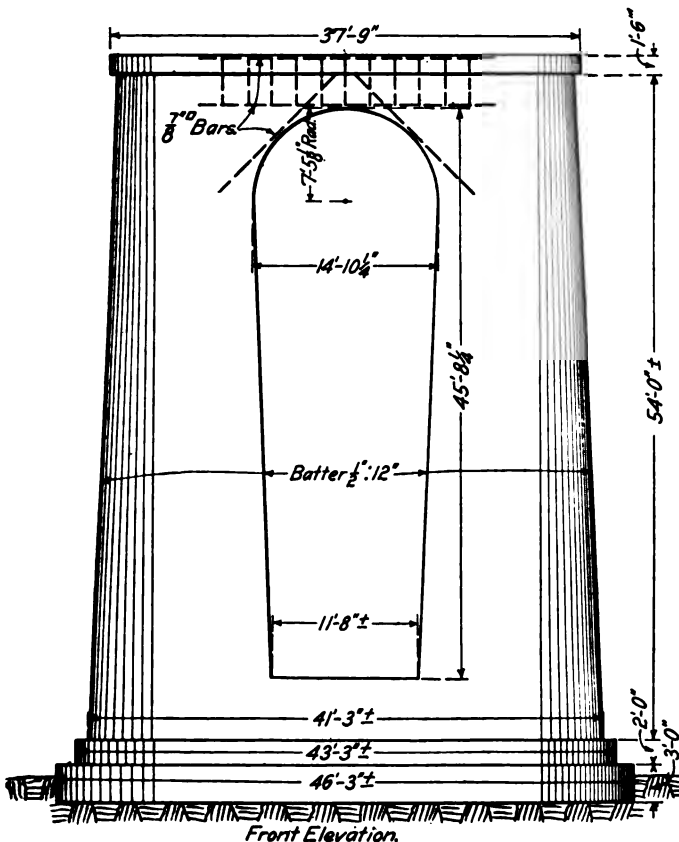

Front Elevation.

Pier 1 of Bridge Over Mulberry Fork of Warrior River.

type 80-ton shovel, 30 16 yd. Kilbourne & Jacobs automatic air dump cars, a Jordan spreader, a Bucyrus all-steel locomotive pile driver and a No. 12 Smith concrete mixer. In the first 11 months more than \$51,000 has been saved over the lowest

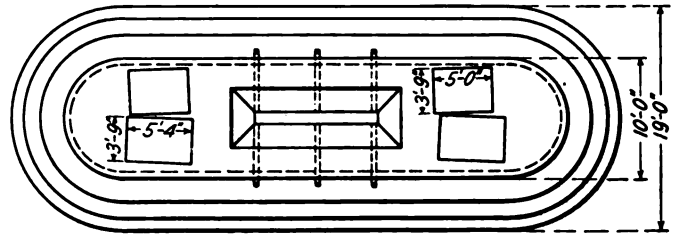

Plan.

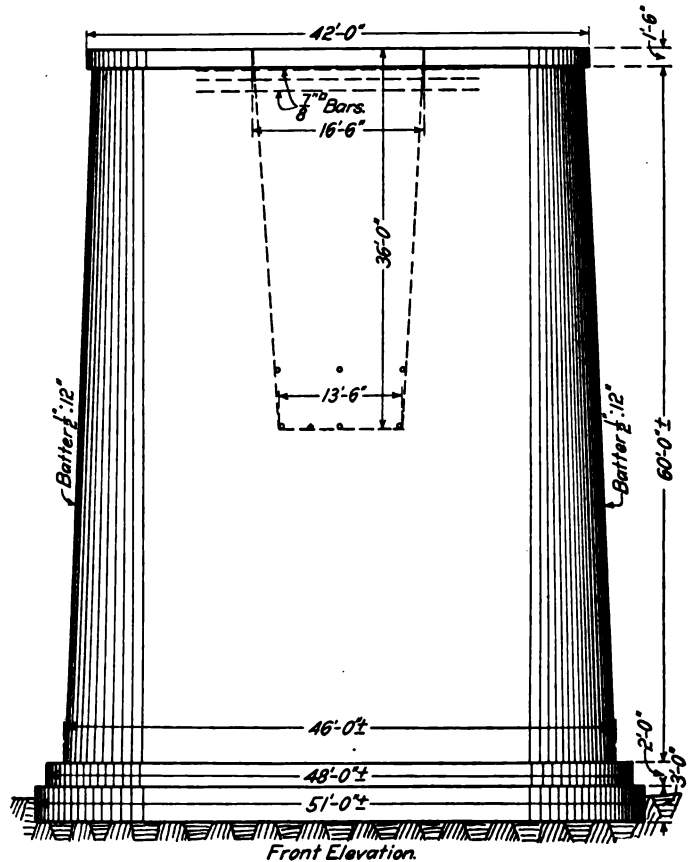

Front Elevation.

Pier 2 of Bridge Over Mulberry Fork of Warrior River.

The use of large cars is principally responsible for the high output since they hold about 13 yds. pit measurement, as loaded by the shovel, and they are usually filled by four swings of the 4.5 yd. bucket. From one to four trains are operated, depending on the length of the haul. The maximum haul is about seven miles and the average haul during a month varies from 3/4 mile to more than 4 miles. Most of the material is secured from one long cut containing about 385,000 yds. The steam shovel is self-propelling and is equipped with air brakes to enable it to operate safely on steep grades. A special tank car was made from an old engine tender, the rear end of which was fitted up as a shop for making light repairs to the shovel

and other equipment. The tank holds water enough to supply the shovel for a half day's run and is filled twice a day by one of the work train engines. The force employed on the work includes three shovelmens, six pitmen, three train crews, twenty bridgemen building trestles and about 75 laborers changing track and cleaning up cuts.

About three miles of the fill, averaging about 10 ft. high, is being made on a swamp. In places the roadbed width on this fill is being made as much as 40 ft. to insure stability, although the standard is only 31 ft. It has been necessary to build two sections of temporary main line, each about 1.5 miles long, in order to avoid interference to traffic during construction work. Portions of the work which could be handled to the best advantage by a team outfit, were contracted to a local contractor, as the amount of such work would not have warranted the company in equipping for it.

#### DECATUR-BANGOR SECTION.

For about 20 miles south of Decatur the work is comparatively light, the material being mostly clay with some rock.



Bottom Heading in Rock Tunnel Near Blount Springs.

The new work is close to the old line, the changes in alignment being made to eliminate excessive curvature in a few places. Between Wilhite and Holmes Gap the line strikes a much rougher country and no satisfactory 0.5 line could be laid to reach the higher elevation at Holmes Gap. The old 1.25 per cent. grade was therefore retained for about five miles, the alignment being changed somewhat to eliminate curvature and the grade adjusted slightly to compensate for curvature. The line is benched into solid rock on a steep side hill for most of the distance and follows a small creek for the remainder. In some places retaining walls were necessary to decrease the amount of fill on this side hill, and in other places the creek has been diverted to avoid crossings.

A very difficult problem was presented by a 120 ft. side hill cut on the uphill side of the operated line near the foot of this pusher grade. The material was solid rock down to about 15 ft. above grade and to prevent obstruction to the main track, the blasting had to be handled very carefully. A shovel was

operated at an angle with the old line and the blasting was done against a vertical face. By careful work the main line was only blocked 15 min. during the course of the work.

From Holmes Gap, south about 21 miles to Bangor, the country is somewhat easier and a large percentage of the material is clay. On fills along the old line the contractor is required to handle work so as not to disturb the main track, although if he is using standard gage equipment he is allowed to operate over the main line. The operators necessary for blocking trains during such work are furnished and paid by the railway and trainmen are furnished by the road and paid by the contractor.

The new grade through the town of Cullman requires a cut having a maximum depth of 20 ft. As this passes directly through the center of the town it was necessary to build five viaducts to carry streets over the line and to relocate the freight and passenger stations near the grade point. The viaducts are of reinforced concrete providing 28 ft. roadways and two 6 ft. sidewalks, with the exception of one case where the sidewalk is omitted on one side. The viaducts are carried on four bents of two columns each, the three spans being 33 ft. each. The footings are spread as the material is clay, those supporting the end bents being carried down 4 ft. below the ground line and those under the intermediate bents 6 ft. The clearance over the tracks is 22 ft. The columns in each bent are connected by a cross beam, those in the intermediate bents being 5 ft. deep and 15 in. thick, and those in the end bents 4 ft. 3 in. deep and 12 in. thick. In addition to these bents the floor is supported by beams 30 in. thick and 3 ft. 9 in. deep suspended in the middle of each span by steel rods from the concrete girders located over the columns between the roadway and sidewalks. The rods are carried through bearing plates on top of the girders and under the bottom of the beams, the nuts on the ends of the rods being tightened before the removal of the forms and secured in place by cotter pins. They are then painted and covered with a coating of mortar. The roadway slab is 13.5 in. thick, covered with a 6 in. macadam pavement. The sidewalk slab is 6 in. thick, and is supported on brackets cantilevered out from the cross girders. A plain concrete railing 6 in. thick and 3 ft. 9 in. high is provided along the outer edge of each sidewalk.

The viaducts were designed for a live load of 100 lbs. per sq. ft. of roadway and sidewalk, or a 35,000 lb. road roller on the roadway and 100 lbs. per sq. ft. on the sidewalk. Each of the double sidewalk structures required 28 tons of steel and 250 yds. of concrete. Some difficulty was experienced in building these viaducts on account of the necessity of placing practically all of the steel before any concrete was poured, so that the reinforcement in the various parts of the structure could be well interlocked. The columns were all cast up to the floor level, then the steel for the cross beams, floor girders and railing was placed before the floor was poured. A longitudinal and a transverse construction joint were allowed in the floor, the girders and railings being placed in a continuous operation. The concrete was mixed by a  $\frac{3}{4}$ -yd. mixer, the plant being shown in one of the illustrations. All concrete was a 1:2:4 mixture.

The new passenger station is of brick with stucco finish, tile roof and terrazzo floors. The freight depot is 50 ft. x 250 ft., with brick walls and wooden roof trusses covered with composition roofing.

One rock cut just north of Garden City containing about 50,000 yds. with an average depth of about 15 ft., occasioned considerable trouble to the contractor on account of the difficulty and expense experienced in getting an explosive that would move the material. It was solid seamless sandstone, so hard that 40 per cent. dynamite charges spaced 6 ft. apart failed even to spring the holes. The contractor secured blasting gelatine, an explosive of much higher power, and had representatives of the Du Pont company examine the material. They advised placing the holes at 4 ft. intervals, which was done, but the material

still failed to break up. Finally the holes were spaced even closer, and it was necessary to shoot them several times. At one time the contractor's accounts showed that this rock had cost \$1 a yard for blasting alone.

The new line crosses Mulberry Fork of Warrior river between Garden City and Bangor on a steel viaduct consisting of three 70 ft. and one 35 ft. deck plate girder spans and two 120 ft. and one 150 ft. deck trusses on concrete piers. Two of the piers are of unusual design. They are 60 ft. and 66 ft. high, respectively, and in order to reduce the quantity of concrete, the two designs shown in the drawings were adopted. In one case a hole 11 ft. 8 in. wide at the bottom and 14 ft. 10¼ in. at the top was left in the bed of the pier, extending down to 5 ft. above the top of footings and up to 4 ft. 6 in. below the top of the pier. This design requires 563 cu. yds. for a height of 60 ft., and top dimensions of 30 ft. x 37 ft. 9 in. The other pier has a cavity 36 ft. deep extending down into the center of the pier from the top. This hole is battered from 5 ft. x 16 ft. at the top to 2 ft. x 13 ft. 6 in. at the bottom. Drainage is provided by placing six 3 in. cast iron pipes through the walls of the piers near the bottom of the hole. This design requires 1,155 cu. yds. for a height of 66 ft. and top dimensions of 10 ft. x 42 ft.

Just north of Bangor the new line crosses the old twice on a steep side hill to reach higher ground. At one of these crossings the new line is about 40 ft. above the old, and as the angle of the crossing is very acute, there was a very long section of the new fill which could not be made without encroaching on the old line. It was calculated that 800 ft. of temporary trestle would have been required to make a temporary crossing and put traffic on the new grade. To avoid this expense it was decided to build a temporary line at a grade intermediate between the old and the new lines. To do this the side hill cut between the two crossings was put through at the proper grade, then a single track cut was made as deep as possible in the bottom of the new cut along the upper slope. The elevation reached in this cut was low enough to allow a crossing of the old line to be made on which traffic could be carried temporarily. The cut at the adopted grade of the new line was made wide enough on the down-hill side to allow a double track to be laid adjacent to the temporary single track cut so that after traffic is turned over the temporary single track, allowing the old line to be abandoned, the fill can be brought up across the old line to the new grade and traffic then shifted to a double track laid slightly out of line through the new cut. After this line is in use material can be brought in to fill the excavation made for the temporary single track and the new double track can then be shifted into its proper location.

#### TUNNEL WORK.

Near Blount Springs there are two tunnels about two miles apart. The shorter one, about 1,000 ft. long, is in very hard rock, most of which is limestone with some ledges of sandstone and slate. No timbering was required during the driving, although it is expected to line the tunnel after its completion. A bottom heading 6 to 8 ft. high extending the full width of the double track tunnel was driven from the north end for the entire length. This heading is shown in one of the photographs. A Marion 41 shovel, operated by air, then started removing the full section from the south end. In shooting down the upper portion of the section, holes were drilled as nearly vertical as possible from the heading up to roof grade. The charges were located in rows of six holes each, the rows being spaced eight ft. apart. Only one row was fired at a time. During the driving of the heading, red paint lines located along the walls of the heading one foot above subgrade and along the roof on the center line were furnished by the engineers for the guidance of the foremen. The contractor was able to make about 50 ft. a week in the heading and about 75 ft. a week in the bench. The muck was hauled from the steam shovel in eight yard cars pulled by narrow gage dinkies burning coke.

The larger tunnel, which is about 2,100 ft. long, was in fairly good rock with the exception of 130 ft. at the north end, where it pierced an old fault. The material encountered at this end was loam and loose rock with many boulders. The method of driving was to put through a center drift, 7 ft. x 16 ft., at about the grade of the springing line without timbering, then enlarge this heading to the full arch section and place the wall plates and arch rings. This tunnel is to be lined with concrete after its completion. When an attempt was made to enlarge the heading in the north end to the full arch section, trouble developed immediately with the soft material. The arch rings were entirely insufficient to sustain the pressure on them. Extra timber consisting of six 8 in. x 8 in. crown bars with 2 in. x 8 in. lagging and 4 in. x 8 in. spacers between the crown bars were placed first and the arch ring timbers were erected inside of this falsework, packing being placed between the falsework and the arch. As there was very little cover over the tunnel at this end a great deal of bracing was required to resist the side pressure of the soft material and a very heavy portal had to be built. The falsework alone required 70,000 ft. of timber in the 130 lineal feet of tunnel section. It was found that the foundation for the wall plates was so soft that they would not support the arch timbers, making it necessary to drive drifts at subgrade on each side and build reinforced concrete footings 2 ft. thick, extending in toward the center line 8 ft. Plumb posts were then set on these footings to carry the wall plates. The south heading was in much better material but as it was started before the approach cut could be taken out, the heading had to be driven down on an incline to reach the proper grade.

The same contractor handled the construction of these two tunnels and rather than build separate compressor plants at each tunnel, involving expensive work in hauling in machinery and coal, he located a 1,000 h. p. compressor plant at Blount Springs on the old line and piped the air to both tunnels. The maximum distance this air was piped was about three miles. A generator was installed at each tunnel to supply current for lights in the tunnels and camps, the generators being driven by air. Air was also used in many other ways about the work, as wherever a mixer or other machine was needed an air motor was installed to operate it.

A special department has been organized to handle this construction work in charge of John Howe Peyton, assistant to the president and chief engineer of construction, assisted by W. E. Smith, superintendent of construction, and H. C. Williams, assistant chief engineer of construction. The structures and buildings involved in the work were designed in the office of the chief engineer, W. H. Courtenay. The division engineers on the work between Madison and Birmingham were W. S. Morton in charge of work between Madison and Lewisburg; Geo. W. Feagin, in charge of work between Lewisburg and Athens; Theo. Speiden, Jr., in charge of company work between Athens and Decatur, and T. Q. Harrison, in charge of work between Decatur and Birmingham. The section between Madison and Decatur was divided into eleven contracts, exclusive of the section handled by company forces, and that between Decatur and Birmingham into fourteen contracts. We are indebted both to the engineering department of the L. & N. and to the numerous contractors on the work for courtesies extended in securing the above information.

**CUBAN RAILWAY DEVELOPMENTS.**—The Cuban Central Northern Extension Railway, Ltd., has been organized to acquire the interest, right, and title of the Cuban Central Railways, Ltd., in connection with a railway to be built between the ports of Caibarien and Nuevitas, Cuba, including the section of the said railway between Caibarien and Dolores already built and opened for traffic, and the benefit of the work already done on the section between Dolores and Yaguajay; and to build or to continue the construction of the said railway and other lines in Cuba.

## BENJAMIN F. BUSH.

Benjamin Franklin Bush has been elected president of the Western Pacific, succeeding E. T. Jeffery, who has been elected chairman of the board, as announced in our news columns last week. Mr. Bush has been president of the Missouri Pacific since May 1, 1911, and also of the Denver & Rio Grande since January 4, 1912. The extension of his jurisdiction over the western line, therefore, places him in direct charge of a system of nearly 11,000 miles, which is about equal to the mileage under the direct charge of Sir Thomas Shaughnessy, of the Canadian Pacific, or that under the direct charge of Mr. Ripley, of the Atchison, Topeka & Santa Fe. As an operating executive Mr. Bush has been rapidly developing toward such a position ever since he took hold of the Missouri Pacific. He was given at that time one of the most difficult tasks ever imposed on a railroad man, that of rehabilitating a railway that, with the greatest possibilities of success, had been allowed to deteriorate while its neighbors were improving. This work was, of course, too big to have been completed in the two years that Mr. Bush has been in charge of the property, but he was able to show some important results in his first year. Not only did the annual report of the Missouri Pacific for the fiscal year 1912 show an increase in revenues and a decrease in operating expenses, and a reduction of 62.18 per cent. in the net corporate loss, but this marked improvement in operating efficiency was effected while carrying on an extensive program of rehabilitation. At the same time Mr. Bush has succeeded in greatly improving the public relations of the road, and this of itself has had an important effect on the upbuilding of its traffic. No report for a full year has been available since he became president of the Denver & Rio Grande, but the improvement in road bed, equipment and business has already been marked, and many important improvements are now under way. Mr. Bush has previously demonstrated his possession

of the qualities which the Missouri Pacific needed in his work on the Western Maryland, in which the same interests that control the Missouri Pacific were dominant, and the ability which he showed in building up that property physically and in developing its traffic led to his election to succeed George J. Gould on the Missouri Pacific.

Mr. Bush was born at Wellsboro, Pa., on July 5, 1860, and began his railroad career in 1882 as a rodman on the Northern Pacific. It was only a short time before he was promoted to be locating and division engineer. In 1887 he was made division engineer in Idaho and Oregon for the Union Pacific, and remained with that company for about two years. He resigned in 1889 to become chief engineer and general superintendent of the Oregon Improvement Company. He has, therefore, had a considerable experience on the coast and in the far west. His first connection with the Missouri Pacific was in 1903, when he was appointed fuel agent for the company, with headquarters

in St. Louis, and given jurisdiction over all the Gould coal properties in the west and southwest. His work in that position led to his election in 1907 as president of the Western Maryland. His headquarters were changed to Baltimore, but he still retained his connection with the coal properties. When the Western Maryland went into the hands of a receiver, in 1908, he was selected for that position, and was re-elected president when the receivership was ended. While in control of the Western Maryland he entirely rehabilitated that property, and placed it on a sound footing. On May 1, 1911, he was elected president of the Missouri Pacific, with headquarters at St. Louis.

## MEDIATION OF TRAINMEN'S DEMANDS.

On Monday Commissioner of Conciliation and Mediation, William Chambers, with Martin A. Knapp and G. W. W. Hanger, met in the forenoon the committee of managers, and in the afternoon the committee representing the trainmen and conductors. L. F. Post, who was appointed, together with Judge Knapp, a member of the board, was found to be ineligible, since his appointment as assistant secretary of labor of the United States had not been confirmed by the United States Senate. Mr. Hanger has the title of assistant, but apparently there is nothing in the law that will prevent the present work of the conciliation board from being carried on under the direction of Mr. Chambers, assisted by Judge Knapp and Mr. Hanger.

One Tuesday and Wednesday conferences between the board and representatives of the managers were again held, as were also conferences between the board and representatives of the brotherhoods. The present efforts of the board are understood to be directed toward getting the managers and representatives of the brotherhoods to agree on what questions shall be submitted for arbitration. Up till Wednesday the trainmen had continued their opposition to any consideration of the

eight question which the managers have been insisting should be arbitrated at the same time as the demands of the trainmen and conductors for increased wages. Before the passage of the Newlands act the Erie had announced that it would not abide by or have any connection with the arbitration meetings. On Tuesday the conductors and trainmen insisted before anything further was done that the Erie should agree to abide by the decision of the award in the arbitration proceedings, and late on Tuesday night General Manager Stuart, of the Erie, notified the board of conciliation and mediation of the willingness of the Erie to abide by the final decision in the case.

CAPE TO CAIRO RAILWAY, AFRICA.—The wet season has caused a cessation of work on the bridge spanning the Lufira river, thus delaying the opening of the Elizabethville-Kambove section of the Cape to Cairo railway. The telegraph line has been completed to kilometer 137 north of Elizabethville.



Benjamin F. Bush.

# GENERAL FOREMEN'S ASSOCIATION.

Closing Sessions Included Reports on Apprenticeship, Shop Schedules, Driving Box Work, and Engine House Efficiency.

An account of the opening exercises and abstracts of the committee reports for the first two days' sessions of the convention of the International Railway General Foremen's Association at the Hotel Sherman, Chicago, were published in last week's issue, page 96. The following reports and papers were considered on Thursday and Friday.

## APPRENTICESHIP.

A committee on apprenticeship, consisting of F. W. Thomas, supervisor of apprentices, Atchison, Topeka & Santa Fe, chairman; C. W. Cross, superintendent apprentices, New York Central Lines West, and E. V. Lea, presented a paper including a number of answers to questions sent to 45 representative industrial concerns in the United States in regard to apprenticeship. Twenty-five of these letters were to railroad companies and 20 to other corporations, such as engine builders, electrical manufacturers, etc. Both the railroads and the other corporations stated that the results obtained justified the trouble and expense of educating and training the apprentices. On the railroads 77 per cent. of the graduate apprentices remain in service, while the other corporations have only 56 per cent. Seventy-one per cent. of the boys entering apprentice schools on the railroads complete their courses, while the other corporations have only 65 per cent.

The committee recommends that the question of apprenticeship is worthy of consideration for the reasons that apprentices have proven satisfactory from a commercial standpoint, and that graduate apprentices have in many cases been advanced to positions of authority. The apprentice system is found to be satisfactory in shops employing either the day work or piece work systems. To assure the success of the apprenticeship systems, the following principles seem to be vital, whether the organization is large or small:

*First.*—To develop from the ranks in the shortest possible time carefully selected young men for the purpose of supplying leading workmen for future needs, with the expectation that those capable of advancement will reveal their ability and take the places in the organization for which they are qualified.

*Second.*—A competent person must be given the responsibility of the apprenticeship scheme. He must be given adequate authority, and must have sufficient attention from the head of the department. He should conduct thorough shop training of the apprentices, and, in close connection therewith, should develop a scheme of mental training, having necessary assistance in both. The mental training should be compulsory and be conducted during working hours, at the expense of the company.

*Third.*—Apprentices should be accepted after careful examination by the apprentice instructor.

*Fourth.*—There should be a probationary period before apprentices are finally accepted; this period to apply to the apprentice term if the candidate is accepted. The scheme should provide for those candidates for apprenticeship who may be better prepared as to education and experience than is expected of the usual candidate.

*Fifth.*—Suitable records should be kept of the work and standing of apprentices.

*Sixth.*—Certificates or diplomas should be awarded to those successfully completing the apprentice course. The entire scheme should be planned and administered to give these diplomas the highest possible value.

*Seventh.*—Rewards in the form of additional education, both manual and mental, should be given apprentices of the highest standing.

*Eighth.*—It is of the greatest importance that those in charge of apprentices should be most carefully selected. They have the responsibility of preparing the men on whom the roads are to

rely in the future. They must be men possessing the necessary ability, coupled with the appreciation of their responsibilities.

*Ninth.*—Interest in the scheme must begin at the top, and it must be enthusiastically supported by the management.

*Tenth.*—Apprenticeship should be considered as a recruiting system and the greatest care should be taken to retain graduate apprentices in the service of the company.

*Eleventh.*—The organization should be such that graduate apprentices can afford to enter for their life work.

In addition to the principles set forth above, the committee urges the necessity of having adequate instructors for the shop and not neglecting this part of the boy's education because of the school room work. While the great value of the school room instruction is recognized, it is believed the one should supplement the other. The principal objection offered by foremen to apprentices in the shops is the time which must be spent with beginners. With adequate shop instruction the foreman is relieved of this. The boy is given assistance as soon as he enters the shop and is made productive at once. It has been demonstrated that where there are 20 apprentices in one trade in a shop the increased output of the boys brought about by a practical instructor will amply justify the employment of a shop instructor.

*Discussion.*—After reading the paper, F. W. Thomas stated that: "The modern shop offers little advantage for a boy without some one to guide and direct him, for the gang foremen are too busy and have too many other duties to perform to be bothered with green boys. A boy floundering around in a big, modern shop for four years with no kindly hand to help or direct him is what gave the old apprenticeship system a black eye from 1890 to 1905. The apprentice was a failure, for at the end of four years he knew next to nothing of the trade. The Santa Fe said to the general foremen and the foremen: 'We know you haven't the time to pay much attention to these boys; you look out for the output of the shop and your other duties, and we will put a man in the shop whose sole duties will be to look out for the apprentices, who will be responsible to you for the boys' progress and work.' With the present system we have found the boy, with the assistance of his shop instructor, to become productive at once. I believe with Mr. Basford, that the present shops need more such instructors and fewer inspectors. The assistant vice-president on our road, who is responsible for the expenditures in the mechanical department, strongly recommends one shop instructor to each 25 or 30 boys. Such a man will pay for his salary four times over by the better and greater amount of work the boys will be able to do. We are not trying to make mechanical engineers, the colleges furnish these; we are not trying to make draftsmen, the schools furnish these; we want to make first-class skilled mechanics to operate our machines; men who are trained and educated in our ways and our methods, and our standards, whose home and family ties are within our midst."

C. W. Cross, superintendent of apprentices, New York Central Lines West of Buffalo, pointed out the important features to be considered when inaugurating an apprenticeship department. He spoke of the great tendency there was in both the railroads and the manufacturing concerns for making specialists of the men at the loss of the all-around skilled mechanics. The apprentice schools tend to increase the number of skilled men, which in shops, however well specialized, are an absolute necessity. The step that has been taken by the several roads which have established apprentice schools on a comprehensive and broad scale is one of the most important advances that have been made by the railroads in this country for a long time. An apprenticeship system will tend to raise the standard of efficiency among the men. We should not forget to make the proper train-



ing of the young men the first consideration, and the beginning of the value of their service secondary during the first year of their apprenticeship. The best results will be obtained in the end by carrying out this principle. Mr. Cross presented several lantern slides showing various views of apprentice workshops, schools, etc., in both industrial and railroad shops.

C. L. Dickert, assistant master mechanic, Central of Georgia Railway, described the apprentice system in vogue on that road. It was organized under the direction of the educational bureau which handles the class room work only, the shop demonstrator being directly under the control of the local shop organization. The apprentices are required to attend classes of half an hour duration each day. It was deemed advisable to hold the boy in the class room only half an hour, as he does not get tired of the class room instruction in that time, and it gives an opportunity for smaller classes, which allow almost individual instruction.

#### SHOP SCHEDULES.

Henry Gardner, superintendent of apprentices, New York Central Lines East of Buffalo, described the schedule system in operation at the West Albany shops of the New York Central & Hudson River. This application of scheduling and routing the work is simple and flexible, being maintained by the regular shop force. Every feature of the work is fully under the jurisdiction of the local shop management, and is now regarded as almost indispensable by the shop foremen. A careful study has been made of the manufacture of the different parts required on the locomotive so that when an engine enters the shop for repairs a list of the work to be done is made, and the time is allotted for repairing each individual part, so that by adding up the total time a definite and positive date can be set for the engine to be ready for service. These parts are then scheduled to the different shops and gangs, according to the routing system of the shop, and a definite day is set for each part to be completed. A blackboard is provided for each class of work so the workmen may know just when parts for each engine must be completed. The general foreman is provided with a schedule showing just what work is to be finished each day, and is also kept informed as to the delays and the reasons therefor. In this way he is kept in absolute touch with all the work passing through the shop with the least amount of trouble, and is ready to concentrate his efforts at the place most needed. This system has been in effect for over 15 months with many beneficial results. The work of the shops is better balanced, each department is better organized, and there is better co-operation between the different departments. The system works as successfully with piece work as with day work. The foremen know a great deal better just what work is being done and just where to place the blame for any hitch that may occur in carrying out the system. A detailed description of this work was given in the *Railway Age Gazette* of September 20, 1912.

The report of the committee on this subject, of which L. A. North, general foreman, Illinois Central, was chairman, strongly advocated the introduction of shop schedules. The aim of the majority of the railway shops is to turn out the largest amount of work in the shortest possible time, and this can be done by the adoption of a fair and comprehensive shop schedule.

*Discussion.*—This paper was thoroughly discussed from the shop standpoint; men laying off was mentioned as the greatest difficulty met in the operation of such a schedule. But it was pointed out that this could be allowed for to some extent by allotting a little more time to each schedule than was absolutely necessary.

#### DRIVING BOXES.

There were three papers on this subject, which went into the care and maintenance of driving boxes in a thorough manner. George H. Logan, general foreman, Chicago & North Western, Missouri Valley, Ia., also chairman of the committee on this subject, presented a paper which was most complete in its scope. He stated that the driving box and its component parts when

properly machined, assembled and taken care of, give the engine crew and roundhouse foreman but little engine trouble, and prolong the time between engine shoppings to a considerable extent. If the driving box and its parts are not properly taken care of trouble will undoubtedly be experienced from the breaking of frames, rods, rod straps, crank pins, crosshead keys, pedestals, binders, deck and cylinder bolts, excessive wear on the rod bushings and brasses, the loosening of the wrist pin bearing in the crosshead and the spider fit on the piston rod, and, if a Stephenson motion is used, the distortion of the valve gear.

There are many foremen who have allowed or even performed makeshift repairs simply to get the engine out on the road and win the good will of the chief train despatcher or of the division superintendent, but by doing so they sacrifice the earning power and life of an engine in the long run. When an engine fails on the road the superintendent will surely make an investigation, and may even ask, "What discipline was administered to the responsible party?", the guilty foreman then answering for his previous carelessness. When defects are discovered arrangements should be made for a relief engine and the repairs should be promptly and carefully made. Driving boxes, finished except for the boring of the journal and the facing of the hub side, and with the shoes and wedges finished, except the face, should be carried in storehouse stock so that prompt repairs may be made at any shops on the system. On the North Western the boxes made for such stock are usually machined in lots of 12 and distributed as necessary to outlying points. A shop of any considerable size should have its machine tools specially arranged for driving box work.

Mr. Logan strongly emphasized the necessity of doing all the work well, stating that the "good enough" habit which has become so prevalent in railroad shops, has made many an engine a shop candidate while undergoing repairs. Driving boxes and their parts are vitally essential and the repairs should be thoroughly made.

He also described the Markel driving box, designed and patented by Charles Markel, machine shop foreman of the C. & N. W., at Clinton, Ia. With this driving box a front brass on an Atlantic type engine may be removed and a new one applied in three hours. The main brass on the same type of engine provided with the Stephenson link motion, which requires the moving of the eccentrics, may be removed and renewed in from five to six hours. He also mentioned the Markel removable hub plates, of which there are quite a number in use on the North Western. With them the lateral wear on a pair of drivers may be taken up in 1½ hours. Mr. Logan also went thoroughly into the shop practice of performing the various repairs on the driving box and its component parts.

C. L. Dickert, assistant master mechanic of the Central of Georgia, at Macon, Ga., also a member of the committee, presented another paper on this subject, describing each operation in the handling of driving boxes from the rough to the finished box applied to the journal. In speaking of the comparing of shops he called attention to the wide difference in the shop conditions. A small shop with old machinery can hardly be compared with a large, modern shop fully equipped with the latest tools. In the handling of a shop the first and most important step is to perfect the organization. Have a system of handling the work from one machine to the other, and keep regular men on the machines, if possible.

C. N. Newman, general foreman, Atlantic Coast Lines, Rocky Mount, N. C., also a member of the committee, presented a paper which was divided under the following heads: Method of machining driving boxes, shoes and wedges; an economical machine grouping for this work; a good method for fitting up shoes, wedges, and boxes and squaring the engine; methods of rebuilding wearing surfaces.

He called attention to the importance of the driving box with its shoes and wedges in prolonging the life of a locomotive, stating that the running repairs of these parts on the average locomotive are due to improper methods and poor workmanship

on them while the engine is in the shop for general repairs, and that such treatment holds the engine out of service longer and costs more than the repairs to almost any other part of the machine.

*Discussion.*—The necessity of careful maintenance of the driving box and its component parts was clearly brought out in the discussion. Wide journal boxes were spoken of as giving most excellent results and greatly reducing the trouble formerly experienced on heavy power. On the Delaware, Lackawanna & Western a special organization is maintained for the caring of driving boxes. The road has educated its engineers to carefully watch this part of the locomotive and repair the slightest defects.

**ENGINE HOUSE EFFICIENCY.**

William Smith, roundhouse foreman of the Chicago & North Western, at Boone, Iowa, pointed out in his paper that an efficient engine house will give a correspondingly good engine performance. There are many conditions that have a bearing on this subject, which make it more or less complicated. Roundhouse men should be consulted on locomotive design, in regard

fittings having any intrinsic value are returned to the storehouse in exchange for new material. The stock in the storeroom should be carefully studied, as there is nothing that will decrease the efficiency of an engine house so much as not having the proper material at hand.

As engine failures are controlled to a large extent by the human element in the organization, care should be taken that proper discipline is maintained. Every opportunity should be grasped to decrease the number of failures, and each failure should be reported and promptly investigated so as to place the blame where it belongs. It is suggested that a daily report of failures on each division should be posted in a place where all may see them, as this would tend to create a feeling of rivalry between the men concerning the operation of their engines. Various devices may be applied to locomotives which will prevent engine failures, and an engineer notified as to the trouble he may expect from his engine, will be able to watch for that trouble, and in many cases prevent engine failures. Careful, thorough periodical examinations and tests should be given all engines, and all adjustments and repairs should be thoroughly and quickly

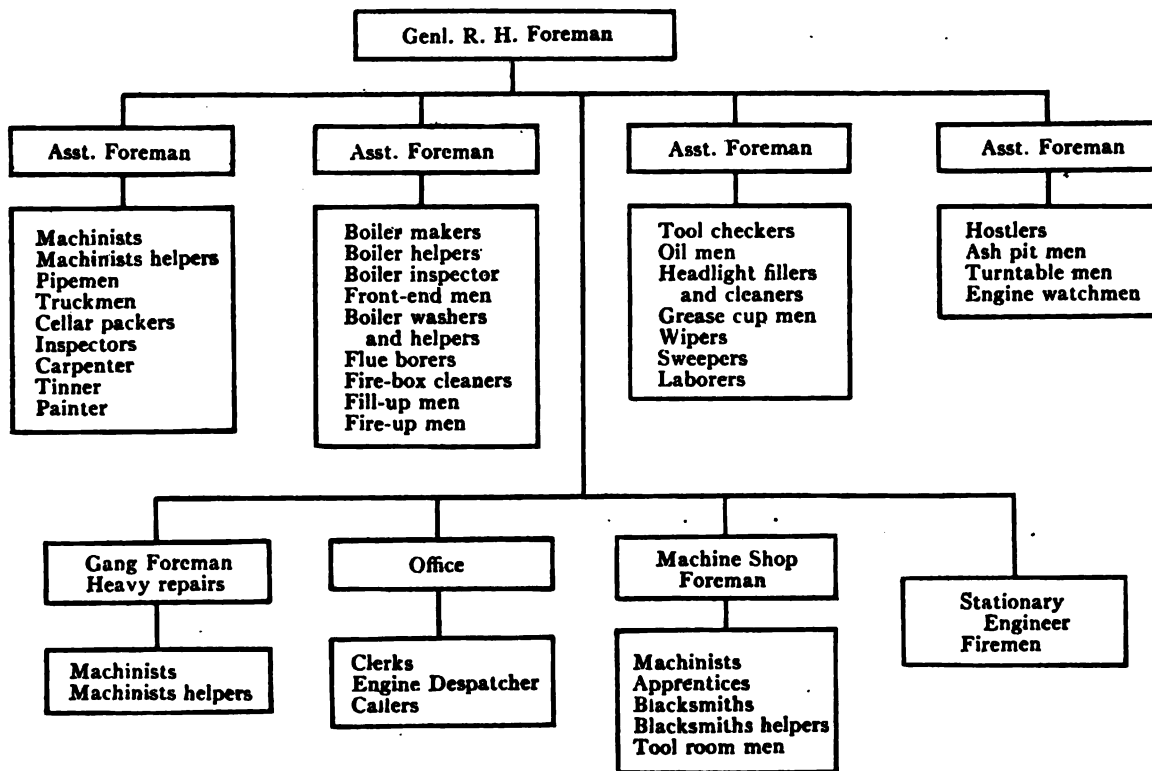

Engine House Organization Where Engines Handled Are Largely of One Class.

to the location and design of parts that have proven inaccessible and unreliable. For instance, it would be a great improvement to provide boiler checks with shut-off valves in such a position that the checks may be reground with the engines under steam. In order to compare the relative efficiency of engine houses, the following items should be considered: Cost of engine repairs per mile; cost of handling per engine; mileage per engine failure; mileage between general repairs; average time of engine detention, and the per cent. of the total number of engines despatched, which are furnished on time.

The aim of the engine house management should be to so maintain the power as to make the greatest possible mileage between shoppings and engine failures, to minimize the time out of service due to handling and repairs, to keep the cost of handling and repairs down to the lowest possible figure, and lastly to furnish engines on time. The foreman is in a position to know what kind of material is needed on certain engines, and either he or his assistant should write out all requisitions for such material. Care should be taken to see that all scrapped

made. Although it costs money to hold an engine out of service, it may cost more later if engines run without necessary repairs.

A terminal daily report is recommended, giving the time of arrival of each engine at the ash pit, the time in the engine house, the time the engine is ready for service, the time used in preparing the engine, the time ordered, the time out of the house, the total terminal delay, and the cause of any unusual delay. This should be furnished the division superintendent and the master mechanic.

It is essential that an engine house have a good, effective organization. The foreman should be free to see that things are running smoothly, and not entailed with too much detail work. The accompanying diagram show two plans of organization. One is for the engine house which handles engines mostly of one class, either freight or passenger. The second is for the large main line engine house, handling both freight and passenger engines. Both of these organizations are intended for engine houses segregated from the back shop.

The operating board is quite essential for keeping track of the

work done on an engine. Other boards located at various places throughout the engine house should be used to give necessary information to the roundhouse men concerning the engines in the house. A running log, or information book, should be maintained at each engine house to keep the day and night foreman informed as to the progress of the work in the previous shift.

Careful inspection is especially necessary to obtain the most satisfactory results. Some roads have provided inspection pits on the incoming tracks where the engines are inspected as soon as they reach the terminal and before the engineer leaves. This is of a distinct advantage as the work of repairing may be started at the earliest possible moment. These inspectors are called upon to make minor repairs, such as tightening nuts, etc., or else are furnished with assistants for doing this work.

OTHER BUSINESS.

E. W. Pratt, assistant superintendent motive power, Chicago & North Western, gave a short talk at the Friday morning session. The members took a trip through the Chicago avenue shops of the Chicago & North Western Thursday afternoon. It was voted to have the topic on engine house efficiency continued for another year.

The following officers were elected for the ensuing year: President, W. W. Scott, general foreman, Delaware, Lackawanna & Western; first vice-president, T. F. Griffin, general foreman, Cleveland, Cincinnati, Chicago & St. Louis; second vice-president, L. A. North, shop superintendent; Illinois Central; third vice-president, William Smith, Delaware & Hudson; fourth vice-president, W. T. Gale, machine shop foreman, Chicago & North

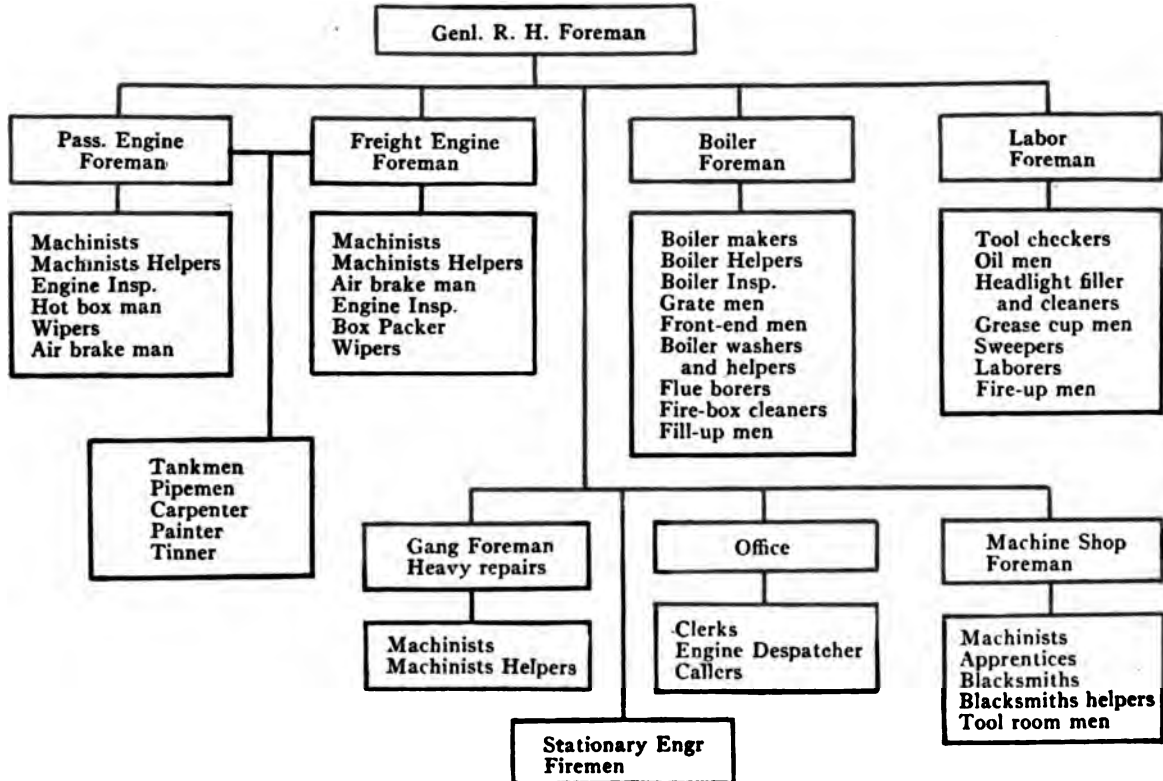

Organization for Large Main Line Engine House.

Ordinary running repairs should be carefully noted on written reports by the engineer and inspectors, and some good system should be used to take care of the incomplete work reports so that the work may be followed up and finished as soon as possible. The work report books should be accessible to the engine-men so that they may know what has been done to their engines while in the roundhouse.

Care should be taken that sufficient instructions are posted or given to the engineers in regard to the use of new appliances. This will oftentimes prevent an engine failure and allow the engineer to obtain the best use of the device. The engine house should have every facility, such as a good turntable, drop pits, toolroom, and proper equipment to aid the workmen in the performance of their duties. Oftentimes considerable rush work, although important, has to be done at the engine house and every facility should be had for making this work a permanent job instead of only a temporary makeshift.

The engine house should be kept clean, well lighted and well ventilated, in order to get the best service from the workmen. Whitewashed walls brighten up an engine house to very good advantage. Too much stress cannot be placed upon the importance of properly maintaining all the equipment, and every provision for safety should be made, for even when the conditions are the best there are more or less dangers connected with engine house work.

Western; secretary-treasurer, William Hall, general foreman, Chicago & North Western.

SPANISH RAILWAY SOLD.—The purchase of the Bobadilla-Algeciras Railway by the Andaluces Company will have an important effect on the Spanish railway operations and development. The 110 mile Bobadilla-Algeciras line runs from Algeciras across the bay of that name from Gibraltar to Bobadilla. Traffic between any two of the cities of Algeciras, Seville, Cordoba, Jaen, Granada and Malaga passes through Bobadilla, and passengers and freight between the ports of Gibraltar and Algeciras and the interior of Spain must use the Algeciras-Bobadilla line. The Andaluces Company, which is controlled by French interests, is the principal railway system in the south of Spain. It has 672 miles trackage, its main lines connecting the principal cities of the south of Spain—Malaga, Granada, Jaen, Cordoba, Seville and Cadiz. The gross receipts of the road from January 1 to September 20, 1912, were \$3,500,000, as compared to \$3,053,000 for the same period of 1911. In 1911 it carried 3,603,292 passengers and 1,828,330 tons of slow freight, receiving from the former \$1,326,828, and from the latter \$2,677,923, besides \$366,970 from merchandise carried by fast freight, and \$94,985 from sundry sources not specified. In 1911 the total income of the road amounted to \$3,657 per mile, and total expenses to \$2,188 per mile.

### THE BOARD OF CONCILIATION AND MEDIATION.

William L. Chambers has been appointed by President Wilson and confirmed by the Senate as commissioner of conciliation and mediation in accordance with the provisions of the Newlands law providing for the arbitration of controversies between employees of railroad companies and their employers. Martin A. Knapp has been appointed one of the two members of the board and has been confirmed by the Senate, and G. W. W. Hanger has been appointed an assistant commissioner and has been confirmed by the Senate. L. F. Post was appointed by President Wilson as the second member to act with Mr. Knapp, but it was found that he was ineligible, since his appointment as assistant secretary of labor had not been confirmed and therefore he was not an employee of the government within the meaning of the Newlands act.

W. L. Chambers was born in 1852 at Columbus, Ga. He attended Emory College and later received the degree of LL. D. from that college in 1909. He taught school for two years and was admitted to the bar in 1873. He was president of the First National Bank of Montgomery, Ala., in 1888, and was president of the company which founded the town of Sheffield, Ala. His home since that time has been Sheffield,

the commission from 1898 until 1912, when he was appointed by President Taft as chief justice of the newly created Commerce Court.

Louis F. Post, who was President Wilson's choice for the second member, was editor of *The Public*, a weekly paper devoted to politics, municipal and social reforms, and especially to the interests of organized labor in Chicago and the advocacy of the single tax.

G. W. W. Hanger has been chief statistician of the Bureau of Labor Statistics.

### A DAY'S TRAIN RECORD OVER TEHACHAPI MOUNTAIN.

On January 19 last the movement of trains over the Southern Pacific between Bakersfield, Cal., and Mojave, 67.8 miles, a difficult single track line, was the heaviest on record for that section—36 trains, 996 cars; and the successful accomplishment of the day's work without mishap makes the despatcher's sheet worth putting on record; it is given in graphic form on the opposite page. Heavy lines indicate passenger trains and light lines freight trains and engines (helping engines going down hill) without trains.

The line between Bakersfield and Mojave, over the Tehachapi mountains, is operated under severe conditions. This road is



M. A. Knapp.



Copyright, American Press Association.  
W. L. Chambers.



G. W. W. Hanger.

### THE COMMISSIONER OF MEDIATION AND THE TWO MEMBERS OF THE BOARD.

Ala., which is now next to Birmingham, the largest iron producing city of the South. Judge Chambers was the American member of the commission which in 1890 negotiated the Berlin treaty between England, Germany and the United States, and in 1897 was appointed chief justice of the International Court at Samoa, serving until 1901. Since 1901 he has been a member of the Spanish Treaty Claims Commission and is a member of the Alabama Historical Society and other scientific societies, and was the chairman of the board of arbitrators which, under the Erdman Act, passed upon the railroad firemen's claims for increased wages and changed working conditions in the early part of this year.

Martin A. Knapp was born in 1843 at Spafford, N. Y. He graduated from Wesleyan University with the degree of A.B. in 1868 and received his A.M. in 1871, and received the honorary degree of A.M. from Syracuse in 1892. He was admitted to the bar of New York in 1869 and served as corporation counsel for the city of Syracuse from 1877 to 1883. In February, 1891, President Harrison appointed Mr. Knapp a member of the Interstate Commerce Commission. He was reappointed by President Cleveland in 1897 and again by President Roosevelt in 1902 and 1908, and was chairman of

owned by the Southern Pacific company, and is used jointly by the Southern Pacific Company and the Atchison, Topeka & Santa Fe.

This line is single track, constructed through heavy mountainous country. The maximum grade is 2.2 per cent. uncompensated east and west of the summit with maximum 10 deg. 20 min. curvature, all curves being tapered on each end, with standard Southern Pacific spiral.

From Caliente to Tehachapi, a distance of 25 miles, on the west side of the pass, the grade is very regular and averages 2 per cent. on the east side, from Mojave to Cameron for nine miles there is a 2.2 per cent. grade, and from Cameron to Summit it is 1 per cent.

The track is laid with 90-lb. rail of A. R. A. section, with treated pine ties, fully tie plated. The line for the entire distance is fully equipped with automatic block signals. There are 18 tunnels, with a total length of 8,115 ft., and 3,990 lineal feet of trestle and steel bridges. The greater portion of the bridging is west of Tehachapi.

A unique engineering feature exists on this line at Walong, nine miles west of Tehachapi, where the road makes a complete loop. For a considerable distance on the west side of the

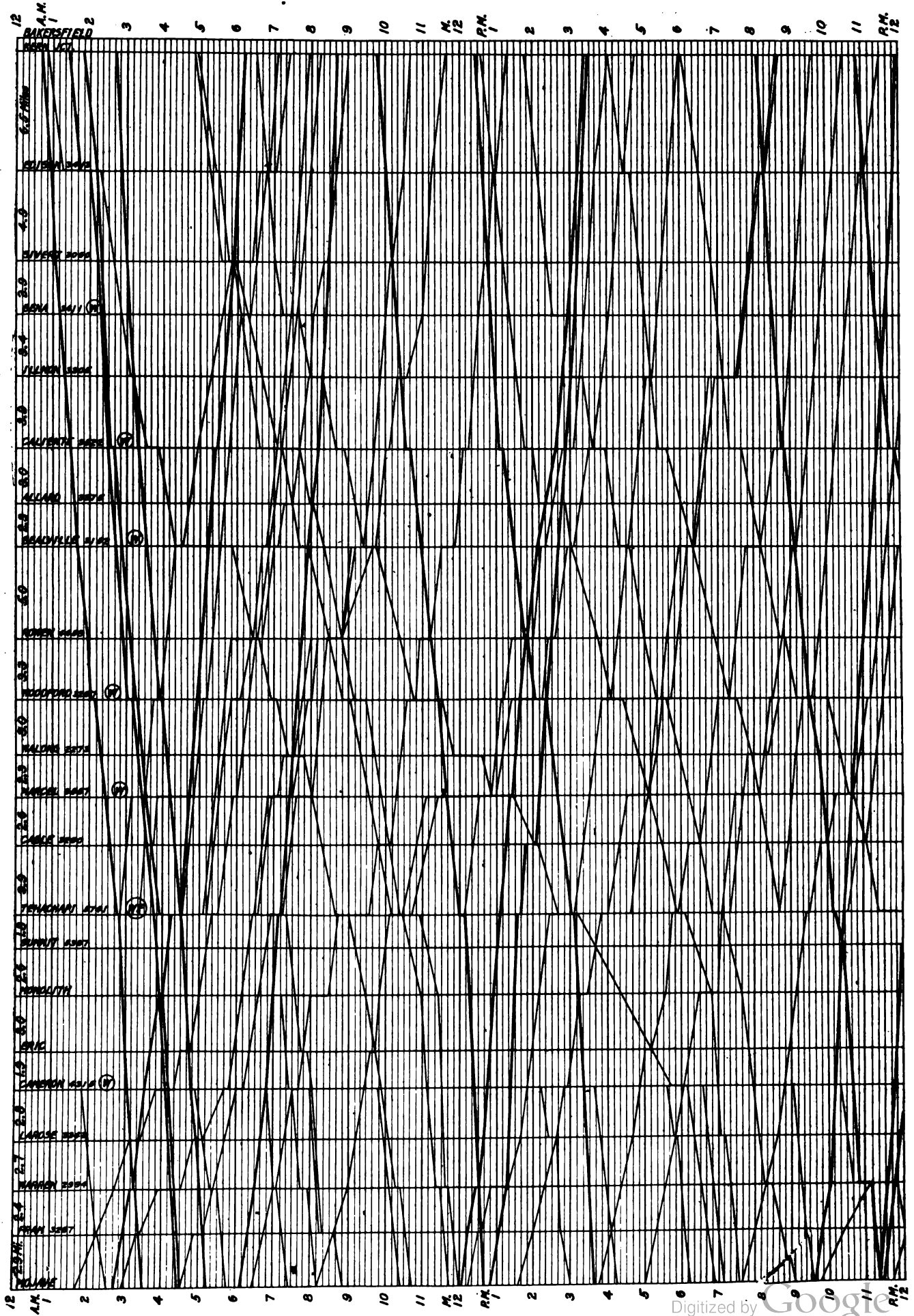

Movement of Trains Over Southern Pacific Railroad, San Joaquin Division, Between Mojave and Bakersfield, January 10, 1913.

mountains, the line parallels very closely Tehachapi creek. Owing to topographic conditions at Walong, it was impossible to construct within the allowable grade. A conical hill exists at this point, and by completely encircling it, the desired grade was obtained. The lower portion of the loop passes under the upper portion by means of a tunnel. The curvature required in this one curve is 566 deg. 33 min., the degree of curve is varying, but the principal complete circle is practically 10 deg. throughout. The distance traversed from the point in the tunnel to the point of crossing above is 3,790 ft., gaining 77.3 ft. in elevation in this distance.

On account of the heavy curvature and grades on the mountain portion as well as the heavy locomotives used on this line, the maximum speed of freight trains is limited to 18 miles an hour, and of passenger trains to 30 miles an hour, both ways.

Helpers are used between Bakersfield and Summit, on the west side of the mountain, a distance of 50 miles, and on the east side, between Mojave and Eric, 13 miles. Tonnage rating of the Mallet type of engines eastward, Bakersfield to Summit, is 1,085 tons, and that of the consolidation engines 450 tons; westward the Mallets are rated at 1,250 tons, and consolidations 505 tons. Freight trains are run with two Mallets or one Mallet and two consolidations, or four consolidations. Passenger trains with six cars or more have helpers, which are returned to their terminals, Bakersfield or Mojave, after helping a train up, the officers feeling assured from experience, that this is the most economical manner of operation. The greater portion of the year the preponderance of traffic is eastward, due, principally, to the production of oil, which is loaded in the Coalinga, Sunset and Kern river fields in the vicinity of Bakersfield and assembled at that point for eastward movement. At this time the oil fields are very active, due to the increasing demand for oil for fuel. In addition to the oil traffic, during the fruit season, oranges and other fruits from the Porterville district move in train load lots over this district. A schedule of five hours and thirty minutes is maintained by eastward, and four hours and thirty minutes by westward trains carrying high class lading. There is also a liberal movement of livestock in its season.

With a view of giving preference to freight trains ascending the mountain, and to prevent their being stopped unnecessarily with resultant damage and delays on account of break-in-twins in starting, the schedules are so arranged on the time table and the time so distributed that they are able to make the schedules with the full loads. Schedules are spaced on the time table and trains run in sections in such a manner as to distribute the movement fairly over the 24-hour period. Schedules of these trains are so arranged that all trains ascending are superior from starting point to the summit.

These schedules were arranged as a result of a number of tests and observations, confirmed by statistics of train movements compiled by the division operating officers. The different kinds of locomotives used during the heavy business portion of the season made it a difficult problem to figure out a tonnage rating consistent with economical operation, without underloading or overloading the locomotives while still maintaining the rate of ten miles an hour ascending the mountain.

Failure of trains to make schedule time on this busy stretch of track results in congestions, necessitating saw-bys, attended by serious delays to trains following as well as increasing the amount of overtime.

Physical conditions forbid the construction of side tracks of sufficient length and the car limit of freight trains is sixty cars, and as a further precaution against congestions, there is a rule that between 7 p. m. and 3 a. m., when passenger trains are frequent, westward freights shall be limited to 40 cars, the capacity of three of the sidings on the descending grade; and the freights are spaced from one to two hours apart leaving terminals.

The train movement over this busy section is further facilitated by the use of telephones in despatching, one set of trich dispatchers handling the 68 miles. As many as 104 train orders

have been sent over the telephone by one despatcher during an eight-hour trick.

The track being protected by automatic block signals, Form 19 is used for train orders which restricts the superiority of trains. Operators fill out a clearance card showing the numbers of the orders for delivery to a certain train and repeat it to the despatcher. The despatcher then gives o. k. and time, which is shown on the clearance. The orders, together with the clearance, are handed to engineers and to conductors without stopping the train.

These features of train movement have been great time savers and a uniform and expeditious movement is carried out successfully. The volume of traffic, for a single track railroad is large and, barring accidents, but few of the trainmen have to be paid overtime.

On January 19, as before stated, the previous record of 978 cars moved over this mountain was broken by the movement of sixteen passenger trains handling 110 passenger cars, 6,305 tons, and 20 freight trains, handling 886 cars, 30,725 tons, a total of 36 trains, 996 cars, 37,030 tons, requiring 137 engines. Seventy-two engine movements were made, or one movement every twenty minutes during the twenty-four hour period. This includes the returning helpers. One hundred and eighty-three train orders were required in the handling of the day's business, or one about every 8 minutes. Schedule trains were moved on time and the entire movement in complete safety.

The following engines are in use by the Southern Pacific over this mountain:

Passenger service; mogul type. Cylinders, 21 in. x 28 in.; diameter of drivers, 63 in.; weight on drivers, 144,120 lbs.; total weight, 166,320 lbs.; heating surface, 2,339 sq. ft.; tractive effort, 33,320 lbs.; these engines use saturated steam. The tenders of the rectangular type carry 6,000 gals. of water and 2,900 gals. oil.

Helpers are used both in passenger and through freight service—these are consolidation type; cylinders, 22 in. x 30 in.; diameter of drivers, 57 in.; weight on drivers, 187,000 lbs.; total weight, 208,000 lbs.; heating surface, 3,403 sq. ft.; tractive effort, 43,305 lbs.; saturated steam. The tenders are of the cylindrical type; water capacity, 7,000 gals.; oil, 3,300 gals.

For freight service Mallet locomotives are used with cylinders 26 in. and 40 in. x 30 in.; diameter of drivers, 57 in.; weight on drivers, 401,000 lbs.; total weight, 435,800 lbs.; heating surface, 6,394 sq. ft.; tractive effort, 94,880 lbs.; superheated steam. The tenders are of the semi-cylindrical type; water capacity, 10,000 gals.; oil, 3,300 gals.

In the diagram the day begins at the top; the left hand is east and the right hand west. The figures against the stations, as, for example, "Edison 3413," "Fram 3287," show the length in feet of passing tracks. The letter W indicates water stations; and F fuel stations.

Starting from Mojave the grade ascends at about 106 ft. per mile to Eric; then at about 55 ft. to the summit; thence down 51 ft. per mile to Tehachapi; thence down at about 106 ft. to Illmon, and the rest of the way at rates varying from 74 ft. per mile to 60 ft. The summit is 4,025 ft. above sea level.

**SURVEYS FOR RAILWAYS IN COLOMBIA.**—The Colombian government has named a commission of engineers to make the preliminary survey of the route of the railway recently provided for by congress from the Department of North Santander to the Magdalena river, consisting of Drs. Fabio Gonzalez, Salvador Uribe and Carlos Julio Canal. The commission will begin work at once.

**NARROW-GAGE LINE FOR SPAIN.**—The concession and construction of a narrow-gage railway from the station of Las Arenas to the quarry of Neguri, province of Vizcaya, has been awarded to La Compañia de los Ferrocarriles de Santander á Bilbao. The rolling stock of this road must comprise at least 1 engine, 1 first class passenger car, 1 first and second class passenger car, and 6 flat cars. The estimated cost of the line is \$32,400.

**TOOL FOREMEN'S ASSOCIATION.**

The fifth annual convention of the American Railway Tool Foremen's Association was held at the Hotel Sherman, Chicago, July 22-24. J. Martin, tool foreman of the Cleveland, Cincinnati, Chicago & St. Louis at Indianapolis, Ind., presided. The opening address was made by E. W. Pratt, assistant superintendent motive power and machinery of the Chicago & North Western. He laid special stress on the great importance to a shop plant of a well equipped tool room whose function it is to keep all of the tools in good condition.

President Martin, in his address, emphasized the importance of operating the tool room in an efficient manner, and particularly in the handling of scrap tool steel. The work of the tool room affects the efficiency of the entire shop and the foreman should not only see that the tools are maintained in proper condition, but should study the shop operations with a view of devising new tools to do the work in a shorter time.

**RECLAMATION OF SCRAP TOOL STEEL.**

J. J. Sheehan, Norfolk & Western, Roanoke, Va., chairman of the committee on this subject, pointed out that care must be taken in using scrap tool steel in order that the cost of reclaiming does not exceed the cost of the new material; but where opportunity is offered the discarded tool steel could be reclaimed to good advantage. As an example, he cited several cases, as follows: Out of 6,500 lbs. of tool steel purchased at a cost of 50 cents a pound, it was found that the scrap amounted to 2,600 lbs., which, if it could be worked over, would represent a saving of some \$1,300. As tools become too short or are unfit for further service they are sent to the smith shop, reheated and forged down to smaller sizes. From 600 lbs. of scrap steel thus treated, 500 lbs. of serviceable tools were delivered to the tool room at a cost of five cents a pound, showing a saving of \$225. Out of 315 lbs. of cutters for the Davis boring bars for 7 in. bore, 250 lbs. of scrap steel were annealed and redressed for 6½ in. cutters for boring bars of the same make, representing a saving of \$112.50. In the same way the 6½ in. cutters were again redressed for 6 in. cutters. Similar savings may be made in chaser dies, taps, reamers, punches, punch dies, rivet sets, flue expander pins, etc. By pursuing a systematic recovery of scrap tool steel, and having a scheme of utilizing the material in small sizes and shapes, a saving may be effected which is well worth the time and attention required.

E. R. Purchase, Boston & Albany, Springfield, Mass., also a member of the committee, stated that on that road they take the largest wheel lathe tools of high speed steel and keep drawing them down until they are ¼ in. or ½ in. square, for use in tool holders.

A. R. Davis, Central of Georgia, Macon, Ga., stated that the design of tools has much to do with their reclaiming when they are worn to the limit. This applies to milling cutters, reamers and taps. Those with the wide, shallow flutes may be recut easily with the same number of flutes by using a fluting cutter of decreased angle. Punches for the boiler shop, that may be reclaimed by reducing their diameter 1/16 in., are ground, while those requiring more stock to be removed are annealed and turned. The accompanying table shows the cost of reclaiming tools in general use, the overhead charges not being included.

**RECLAIMING SCRAP TOOLS.**  
*Taps.*

	Mt'l.	Price per lb.	Reclaim cost	Per cent. salvage
Std. and taper boiler, 1 in. up—cut shanks...	110C.	\$0.17	\$0.03	82
Staybolt—cut shanks for small reamers and taps	100C.	.17	.03	82
Flexible staybolt—turn to smaller tools	110C.	.17	.04	76
Pipe and special—turn to smaller tools	110C.	.17	.04	76
Machine—cut shanks for smaller reamers and taps	H.S.S.	.55	.03	94½
	100C.	.17	.03	81

*Reamers.*

	Mt'l.	Price per lb.	Reclaim cost	Per cent. salvage
Straight and taper, hand—recut 1 in.	100C.	2.50	1.25	50
Straight and taper, hand—turn to stock	100C.	.17	.04	76
Rosebits—recut and use shanks for end mills,		3.90	.70	82
Rosebits—turn to stock	H.S.S.	.55	.031	94½
Special—turn to stock	H.S.S.	.55	.03	94½
Inserted blades—draw to tool holder stock	H.S.S.	.55	.08	85½

*Drills.*

Twist, No. 3 shank—draw stock	H.S.S.	.55	.06	89
Forged twisted—draw stock and counterbore blades	H.S.S.	.55	.04	92½
Special—draw stock	H.S.S.	.55	.06	89

*Milling Cutters.*

Broken cutters—trim and draw stock (poor stock)	H.S.S.	.55	.08	85½
Slabbing, 3 in. to 5 in.—recut, average per 1 in. face	H.S.S.	4.55	.78	83
Straddle, 5 in. x 1 in.—recut	H.S.S.	8.30	1.95	76½
Keyway, 4½ in. x 1 in.—recut	H.S.S.	7.10	1.20	83
End mills—draw shanks	H.S.S.	.55	.06	89
End mills—recut 1 in. in diameter	H.S.S.	2.67	.85	68
Inserted blades—draw stock	H.S.S.	.55	.08	85½

*Boiler Tools.*

Punches—turn or grind	90C.	.32	.06	81
Punch dies—rebore	90C.	.38	.11	71
Shear blades—draw stock	90C.	.17	.02	90
Rivet sets (large)—recup.	Van.	.92	.16	82½
General hand tools—draw stock	75C.	.15	.03	80
Pneumatic blank—to hand	Van.	.17	.03	82

*Machine Tools.*

Standard tool stock—draw to sizes	H.S.S.	.55	.02	96½
Tire scrapers, etc.—cut and draw to 6 in. x 12 in.	H.S.S.	.55	.08	85½
Bolt turning blades—cut to short lengths	H.S.S.	.55	.06	89
Bolt turning blades—draw to tool stock	H.S.S.	.55	.06	89
Counterbore blades—draw stock	H.S.S.	.55	.08	85½
Bolt cutter dies—rehob, 1 in. average	H.S.S.	3.90	.80	79
Bolt cutter dies—draw stock	H.S.S.	.55	.06	89
Wood machine tools—draw stock	100C.	.17	.03	94½

*Forging Tools.*

Drop die blocks—plane for stock	75C.	.17	.02½	85
Flue dies—rebore	Van.	6.85	.60	91
Flue dies—draw stock	Van.	.17	.04	76
Stripper plates—draw stock	90C.	.17	.03	94½
Hand tools—dress to small sizes	75C.	.15	.04	80

**TOOLS NOT RECLAIMED.**

- Small drills, taps and reamers.
- Spindle stay taps.
- Three-flue stock.
- Small milling and all form cutters.

*Discussion.*—The discussion clearly brought out the importance and possibilities of reclaiming or remaking the scrap tool steel into other tools. J. Martin stated that on the Big Four tools were designed in such a manner that when scrapped they may be easily converted into other types of tools. One member uses the electric welding process to weld new tangs or drills. On the Santa Fe the high speed steel has been adopted as standard and all the carbon steel tools have been returned to the storehouse and credited back to the mechanical department. Thirty tons of this material has been sold back to the manufacturers. Surplus tools are not allowed to collect at any of the shops, they being turned back into the stores department. It was clearly developed that in order to obtain the best results from tools the best grade of steel is necessary.

**SUPERHEATER TOOLS.**

Fred Peterson, Colorado & Southern, Denver, Colo., a member of the committee, described the different tools used on the Emerson superheater as applied to their engines. In repairing the large flues at the front tube sheet it has been found expedient to place a coupling in the small superheater tubes near the header, so that they may be more readily removed when it is desired to work on the large flues on the front tube sheet. It was also found that the check valve was placed too near the front tube sheet, and a distance of 30 to 36 in. back from the front tube sheet was recommended so that the change in the temperature, due to the feed water, would not affect the large superheater tubes in the tube sheet.

A. R. Davis, Central of Georgia, Macon, Ga., described the special tools used to maintain superheaters. While that road has not had enough experience in handling superheater tubes, it is believed that it will be economical to maintain special tools for the handling of superheater flues.

*Discussion.*—There seemed to be a difference of opinion as

to grinding the header for the ball on the end of the unit pipes. Some roads do not do this and report satisfactory results. The Santa Fe issues definite instructions to the boilermakers concerning the use of the various special tools used on superheaters, and many roads follow the method recommended by the Locomotive Superheater Company. It seemed to be the consensus of opinion that it was bad practice to use the self-feeding flue rollers, as they tend to bulge the flues out. Different tools were described for cutting the flues out of the boiler.

#### THREAD CUTTING DIES.

A. W. Meitz, Pere Marquette, Grand Rapids, Mich., chairman of the committee, told of the method of making the chasers, giving the various angles for cutting different metals. He quoted from W. L. Ernst, of the National Machinery Company, relative to the shop practice of that company in making these tools, stating that in any cutting tool proper clearances should be given on the heel of the tool so there will be no rubbing to produce friction and thus heat the tool. The tool should also have the angle or rake on the cutting face to insure free cutting. In designing the interchangeable die the chaser should be of standard bar dimensions so as to use the least amount of stock in making these tools.

J. B. Hasty, Atchison, Topeka & Santa Fe, San Bernardino, Cal., also a member of the committee, stated that dies, like all other cutting tools, must be made and kept in good condition to produce good threads. It is safe to say that one-fourth of all the bolt cutters in operation at present do not cut a clean chip. Most of the threads are only ridges squeezed on the iron. This ruins the dies, and in fact the whole machine.

G. W. Smith, Chesapeake & Ohio, Huntington, W. Va., also a member of the committee, criticized the treatment that threading dies are subjected to. A good, steady man, after thoroughly learning the job of cutting threads, will be found to be a profitable investment, if allowed to continue on the job. Bad, dirty, iron, rust eaten bolts, and a quality of so-called soft steel will also render a good set of dies almost useless. A good bolt-cutting compound or oil is essential to keep the dies in good condition.

*Discussion.*—Most of the members found that the high speed steel did not come in as uniform sizes as the carbon steel, which necessitates turning or grinding. J. Martin, of the Big Four, believed that carbon steel was more economical than high speed steel in most cases. It was pointed out that it was cheaper to keep the die heads in good condition rather than to hob each set of dies for each individual head. Considerable trouble was experienced with warped dies when they were tempered outside of the tool room. On the Central of Georgia the bolt dies are examined each day by the tool foreman. In many cases it has been found that the manufacturers could reclaim special dies cheaper than the tool room organization.

On Wednesday afternoon the General Electric Company gave a demonstration of the electric furnace at its warehouse in Chicago. An account of Thursday's session will be given in next week's issue.

**STRIKE AND CAR SHORTAGE IN SPAIN.**—The Barcelona railway strike caused a slight check to business activity during the latter part of 1912. Farmers were also affected by the shortage in rolling stock of the railways, a condition which has become chronic every autumn when the demand for cars to move the crops coincides with the demand for cars to transport coal and other supplies to the great cities before the winter sets in. More and better railway service for the movement of both passengers and freight is imperative. An improvement has been made in passenger equipment and it is hoped that the increased earnings of the railroads during the past year will enable them to make some additions to the freight equipment.

## General News.

Alexander M. Stephens has been appointed chief of railway mail service by the postmaster general. He began work as a railway mail clerk in 1894. He succeeds Theodore Ingalls.

An attempt is being made to organize the freight clerks employed on the Erie between New York and Buffalo, with a view to asking an increase in rates of pay amounting to about 20 per cent.

About 3,500 maintenance of way employees of the Western Maryland have been given increases in pay averaging about 5 per cent. These men include bridge carpenters, trackmen, masons and watchmen.

Telegraph and telephone operators and station agents on the Northern Pacific are taking a strike vote following the refusal of their demands for increased wages and changes in working conditions, especially for Sunday work.

A bill has been introduced in the Georgia legislature making it compulsory for street railways operating in cities of more than 20,000 inhabitants to provide separate cars for negro and white passengers, and cars with separate compartments in cities of less than 20,000.

On July 18 the boiler of the locomotive pulling the Southern Pacific train No. 11 from New Orleans to Houston exploded, killing the engineman and fireman and injuring a number of other persons. The explosion was caused, it is said, by low water in the boiler.

F. E. Blaser, general superintendent of the Baltimore & Ohio, with offices at Baltimore, Md., has been appointed to the general safety committee of the Baltimore & Ohio and Cincinnati, Hamilton & Dayton, succeeding C. W. Egan, general claim agent, resigned from this committee.

Professor R. Meeker, of Princeton, who has been nominated by President Wilson to be commissioner of labor statistics, has been nominated as the second member to serve with Judge Knapp on the board of mediation and conciliation. The Senate has not as yet confirmed this appointment.

A press despatch from Lisbon, Portugal, says that contracts have been signed for laying two new telegraph cables connecting United States and England by way of the Azores. The contract has been signed by the Portuguese government and by the Europe & Azores Telegraph Company.

The Union passenger station in Chicago was seriously threatened by fire on Sunday night, July 20. The fire is believed to have been started by crossed electric wires in the cupola at the north end of the structure and spread downward through the walls to the main waiting room. It was extinguished after causing damage estimated at \$20,000.

The Baltimore & Ohio began last week paying its employees and also the C. H. & D. employees semi-monthly. Payments are made on the 5th and 20th of each month. The Baltimore & Ohio pays in cash in Baltimore, and outside of Baltimore by check. There are nearly 10,000 employees in and around Baltimore that are paid in cash, and the total payroll last year approximated \$50,000,000.

The State Tax Commission of Ohio figures on which railroad taxes for the present year are to be based have just been made public and show an increase in the taxable value of railroad property of \$32,945,600, bringing the aggregate value up to \$665,074,810. The largest increase is in the valuation put upon the Lake Shore & Michigan Southern, which was \$57,276,460 in 1912 and has now been increased by \$9,160,660.

Frederick W. Whitridge, president of the Third Avenue Railroad and of the Yonkers Street Railway, has ordered double track work to be discontinued in Yonkers because of a dispute between some of the men engaged on this work and the labor unions. In his letter ordering the discontinuation of the work Mr. Whitridge strongly attacks the attitude of the mayor of Yonkers, who has worked to bring about a compromise which should exclude all non-union workers.

A bill has been introduced in Congress by Representative J. Hampton Moore to direct the Secretary of War to negotiate for



acquisition of the Chesapeake & Delaware Canal and to purchase, or in the event of the failure of the negotiations, to acquire the canal by condemnation. The canal runs from upper Chesapeake Bay to Delaware Bay, making a short waterway between Baltimore and Philadelphia. The bill was referred to the Committee on Railways and Canals, a committee which has not met in the recollection of anybody at the capitol.

Wells, Fargo & Company Express have organized an efficiency committee consisting of A. Christeson, vice-president, and E. A. Steadman, vice-president, and Comptroller Newlean. The committee will be assisted in its work by five superintendents. The work of the committee is described as follows: "Scientific efficiency as applied to the express business may be interpreted as making the ablest use of most complete knowledge. It means the accomplishment of more work and greater profit for the company and a rising scale of influence and compensation to the men in service."

The fast mail train of the Chicago, Milwaukee & St. Paul leaving St. Paul and Minneapolis in the evening for Chicago, has been equipped with a new type of marine search-light of 3,000,000 c. p. that throws a stream of light for a distance of three miles, in order to provide a means for the passengers to view the scenery after nightfall. The search-light is adjusted on the observation platform and is in charge of an experienced operator. The light can be swayed 90 deg. from right to left and 45 deg. upward. The road parallels the Mississippi river for 100 miles, and passes a large number of points of interest upon which to play the powerful light.

R. C. Richards, chairman of the Central Safety Committee of the Chicago & North Western, has compiled a statement showing the results of the safety work for the three years ended June 30, 1913, on the basis of the number of accidents occurring during the year ended June 30, 1910. This statement shows that there was a decrease of 28.6 per cent. in the number of employees killed and 24.8 per cent. in the number of employees injured; an increase of 12.1 per cent. in the number of passengers killed with a decrease of 23.6 per cent. in the number of passengers injured, and of 18.8 per cent. in the number of "outsiders" killed. During the three years from 1911 to 1913 there were 229 employees, 37 passengers and 572 "outsiders" killed on the North Western.

The July issue of *The Frisco Man*, the employees' magazine of the St. Louis & San Francisco, contains the following farewell message from B. L. Winchell, who recently resigned as president of that road to become director of traffic of the Union Pacific: "I am saying good-bye to Frisco and its army of fine fellows with real sadness. We have won many a fight together because officials and men stood shoulder to shoulder. No line in the southwest has enjoyed a better growth of traffic than the Frisco, and no employees have made more strenuous and self-sacrificing efforts to handle it well than those who represent this property. I am leaving the organization here intact; the same generals will command, and I know they will receive the same splendid support. Good luck to all of you."

Mrs. E. H. Harriman has just given an additional endowment of \$10,000 to the fund of \$50,000 she established in 1911 for the foundation of a bacteriological and pathological research laboratory, in connection with the hospital service of the Southern Pacific. Dr. F. K. Ainsworth, chief surgeon of the railroad, will have charge of the disposition of the funds. The purpose of the endowment is to further the progress of medical research. For the last two years, the work has been going on under the direction of Dr. W. T. Cummings of the Southern Pacific general hospital at San Francisco. This is the second large contribution to the Southern Pacific hospital service within the last two years, the widow of the late Collis P. Huntington having given \$25,750 for the construction of a social hall now in use at the San Francisco hospital.

The secretary of agriculture has issued a permit to the Pacific Light & Power Corporation of Los Angeles, to build a series of power plants in the Sierra national forest; four power houses, two reservoirs, and 25 miles of cement-lined tunnels. Construction may extend over twelve years. The work is being done by the Stone & Webster Engineering Corporation. The ultimate development proposed is about 150,000 horsepower. The greater part of this power will be trans-

mitted 240 miles into Los Angeles and will probably be used largely for extensions of interurban railways. The power will be transmitted over stranded aluminum cables at a pressure of 150,000 volts, the highest yet attempted in commercial transmission. This development is one of several under way or projected on national forest lands in California.

In order to save the railroad from a receivership and to help it meet a deficit, the people living along the line of the Kansas & Southwestern, a 60-mile road running west from Arkansas City, have asked that the three-cent passenger rate be restored on that line, and that the assessed valuation of the property be decreased by half. At a meeting held in Caldwell, Kan., on July 8, a committee were appointed to present the question of rates to the Kansas Public Utilities Commission, and to ask the state tax commission for the reduced valuation. The line was assessed last year at \$662,000, and it has been estimated that \$70,000 will be required to put the road in proper condition. It was stated at the meeting that people along the line desire the road to continue in operation and are willing to pay the higher rate in order to reduce the deficit, but the committee was instructed to oppose any increase in freight rates.

#### The Sale of Transportation.

It is reported that during the past few months the Packard Motor Car Company has delivered to purchasers, motor cars and trucks, with a total value of \$8,120,000.

#### Unfilled Tonnage of the Steel Corporation.

The report of the United States Steel Corporation shows that the volume of unfilled tonnage on June 30, was 5,807,317 tons, a decrease of 517,005 tons as compared with 6,324,322 tons on May 31. The unfilled tonnage on April 30 was 6,978,762 tons; on March 31, 7,468,956 tons; on February 28, 7,656,714 tons; on January 31, 7,827,368 tons; and on June 30, 1912, 5,807,346 tons.

#### Five Hundred and Fifty Miles Without a Stop.

A press despatch from Berlin, Germany, July 13, reports that a French aviator, Leon Letort, traversed the distance from Paris, France, to Berlin, on that day in nine hours, making no stops. The distance, in an air line, is 550 miles. Letort started at 4:10 a. m., and arrived at 1:10 p. m.

#### Retirement of Colonel Yorke.

Lieut.-Col. P. G. von Donop, one of the inspecting officers of the railway department of the British Board of Trade, has been appointed chief inspecting officer, in place of Colonel Sir Horatio Arthur Yorke, who retires on August 6, owing to the prescribed age limit. Colonel von Donop entered the Royal Engineers in 1871, became captain in 1883, and major in 1890; was inspector of Submarine Defences in India from 1889 to 1894, became lieutenant-colonel in 1897. He has been in the service of the Board of Trade 14 years.

#### The Railroads' Valuation Committee.

Thomas W. Hulme, general secretary of the railroad presidents' Conference Committee on Valuation, has issued a circular to roads not represented in the committee, inviting them to take advantage of its work. It appears that the committee, as formed in April, represents only roads having earnings of over \$1,000,000 a year; and this circular is sent to companies which reported last year a sum smaller than this. The presidents have already secured the appointment by the railroad companies of a committee of engineers and real estate officers, as heretofore announced; and it recommends that each company appoint a valuation committee to supervise its own work. Conferences between committees of different roads, within the same territorial group, are also recommended. Mr. Hulme's address is Broad street station, Philadelphia, Pa.

#### Money for Mr. Mellen.

A statistician of the New York, New Haven & Hartford says that New England is doing this year the greatest summer resort business in her history; and he figures that about 1,400,000 people

spent their vacation within the confines of New England in the year 1912. A compilation based on the hotel and boarding house lists and covering all the railroads shows that last year there were 4,406 hotels and boarding houses in New England with a total capacity of 222,141 persons. For the total number of persons accommodated he multiplies the total capacity by six, figuring on the average vacation being two weeks and the season to consist of twelve weeks. This would give 1,332,846 persons accommodated in the season. Estimates based on these figures and from the reports of hotel keepers would place the amount spent by these vacationists at, roughly, \$100,000,000.

That the summer resort business is one of New England's leading industries is indicated when comparison is made with her agricultural figures. The total value of all of New England's crops in 1909, as given by the census, was \$141,113,829. The total value of her dairy products in the same year was \$50,720,766, or about half the estimated amount which summer visitors spent last year. In 1912 Maine had 1,265 hotels and boarding houses with a total capacity of 69,073; New Hampshire had 1,157, with a total capacity of 55,953; Vermont had 513, with a capacity of 9,194; Massachusetts had 695, with a capacity of 44,676; Rhode Island 163, with a capacity of 15,400, and Connecticut 613, with a capacity of 27,845.

#### Following English Precedent.

A few years ago, the board of directors of the New York, New Haven & Hartford, desirous of making some experiments along this line, appropriated \$5,000 for beautifying the cut through which its main line runs at Mount Vernon, N. Y. This cut extends for several miles and in places is over a hundred feet deep. It is lined in places with brown or gray stone.

The work of beautifying was put in charge of C. D. Perkins, division engineer. The ditches along the tracks were concreted, the long sloping sides of the cut were planted with grass seed and then this was strewn with Dorothy Perkins rambler roses. The result has been a transformation of this part of the line. For weeks this spring and until just recently travelers passing through this cut saw on the slopes above their heads a mass of pink roses against a background of green sward. Each year the display has grown more beautiful. Mr. Perkins has in the last year or two extended the rosebeds until now they are found at Stamford, Riverside, Greenwich, Port Chester and several other places where the soil has been favorable.

#### The B. & O. Annual Picnic.

Arrangements are being made for the thirty-second annual reunion of the Baltimore & Ohio employees, known as the "Jennie Smith" picnic, which will be held at the usual place, Island Park, Harper's Ferry, W. Va., on July 31. This custom was commenced in 1881.

The Baltimore & Ohio men will run special trains from all parts of the system within a day's ride of Harper's Ferry, which includes Baltimore, Washington, Mount Airy, Hagerstown and points along the old main line and from Keyser, Piedmont and Cumberland.

As on former occasions, Miss Jennie Smith, railroad evangelist, who originated the reunion idea, and who has attended every picnic since 1881 will give one of her talks to her "boys" who have named the picnic in her honor.

Miss Smith's evangelistic work among the railroad men was begun on the B. & O. as a young girl. In early childhood, as the result of an accident, she was made an invalid and for several years was bedridden. Specialists were consulted in various parts of the country from time to time, and while making one of these journeys in a B. & O. baggage car on her cot the baggagemaster suggested to the young girl that she might find some relief through prayer. Miss Smith prayed with the railroad man in the baggage car, promising to devote her lifework, if restored to the use of her limbs, to the men of the railroad.

#### Parcels Post Maximum Increased.

On August 15 the maximum weight of parcels post packages is to be raised from 11 lbs. to 20 lbs. At first this maximum of 20 lbs. will apply only to parcels sent to the first or second zone from any given post office, a distance of about 150 miles.

There will also be made a reduction in rates on packages moving to first or second zone destinations. Thus, the rate on a package weighing more than 4 oz. will be reduced from five cents for the first pound and one cent for each additional pound or fraction thereof to five cents for the first pound, and one cent for each additional two pounds or fraction thereof; and the rate for the second zone will be reduced from five cents for the first pound and three cents for each additional pound to five cents for the first pound and one cent for each additional pound. The insurance fee, which has been heretofore 10 cents, has been reduced to five cents for parcels valued up to \$25 and is now 10 cents for parcels valued at from \$25 to \$50.

Congress has shown some opposition to these proposals of the Postmaster General, and has asked Mr. Bursleson for an explanation of his plans.

#### Tickets for Train Escorts.

The following is a letter which appeared in the New York Times, signed "A Railroad Official, Abingdon, Va.":

I notice a letter from T. Barton suggesting that tickets be sold for the use of escorts who wish to accompany passengers to trains. I have been wondering for several years why this plan has not been adopted at the large stations in the United States, as it seems to work in a first-class way on the Continent.

While at the Manhattan station the Pennsylvania does not seem to need it so much because the gates are so close to the trains, it would be a great accommodation to the public at Jersey City, Philadelphia, Washington and some other Pennsylvania stations, if a nickel automatic slot machine were provided, where escorts and friends who desired to go through the gates might purchase tickets.

#### Superheaters for New Haven Locomotives.

The New York, New Haven & Hartford will equip about 350 of its locomotives with superheaters. The locomotives will be overhauled at the rate of five a month at a total cost of about \$1,000,000. All of the 50 new Pacific type locomotives just acquired by it have superheaters. The large outlay required by this work is justified by the fact that while hauling capacity of a locomotive is increased about 20 per cent., there is at the same time a saving effected of 20 per cent. in coal and 25 per cent. in water. The work of overhauling the locomotives of the New Haven system will be done at the Readville, Mass., shops.

#### Coroner's Findings on the New Haven Wreck.

The coroner, John J. Phelan, in his findings in the investigation of the wreck which occurred on the New York, New Haven & Hartford on June 12 at Stamford, holds that neither Doherty, the engineer, nor the management were to blame for negligence in connection with the wreck. The coroner finds that the management exercised due care in testing Doherty's competence, and says that the charges of incompetence made against Doherty have been disproved in the hearings before him. The coroner's findings in regard to Doherty are not particularly clear, but he absolves the engineman of any criminal negligence. The coroner says that while he erred in not setting the brakes sooner, he did set the brakes when he honestly thought that it was necessary.

#### Exhibitors at the Tool Foremen's Convention.

Among the exhibitors at the convention of the American Railway Tool Foremen's Association, held at the Hotel Sherman, Chicago, July 22-24, were the following:

Allen & Co., Edgar, Chicago.—Tool steels. Represented by J. J. Cruice, R. G. Bennett and Robert A. Anderson.

American Specialty Company, Chicago.—"Use-em-up" drill sockets. Represented by H. L. Mills.

Brown & Company, Tom, Chicago.—Expanders, flue cutters, beading tools, flue hole cutters and adjustable hand reamer. Represented by Harry W. Stannard.

Carborundum Company, Niagara Falls, N. Y.—General line of carborundum, Aloxite wheels, Aloxite cloth in economy rolls. Represented by C. C. Schumaker, R. H. Hogg and J. F. Hanlon.

Celfor Tool Company, Buchanan, Mich.—High speed forged twisted drills, forged reamers, three-lip drills, flue sheet drills, flue cutters. Represented by W. Nochumson and C. O. Montague.

Chicago Pneumatic Tool Company, Chicago.—Pneumatic air drills and hammers, Duntley electric drills. Represented by C. E. Walker, J. C. Campbell and P. F. Flavin.

Cleveland Twist Drill Company, Cleveland, Ohio.—Twist drills and reamers, Paragon drills, Peerless and Paradox reamers and double tange sleeves. Represented by H. S. White.

Colonial Steel Company, Chicago.—Samples of steel. Represented by H. A. Montgomery and James E. Berry.

Desmond-Stephan Manufacturing Company, Urbana, Ohio.—Grinding wheel dressers. Represented by C. N. Kohler.

Eagle Claw Wrench Company, Chicago.—General line of wrenches. Represented by Eugene Ambler.

Faessler Manufacturing Company, J., Moberly, Mo.—Expanders, cutters, etc. Represented by G. R. Maupin.

Independent Pneumatic Tool Company, Chicago.—Drills, riveting and chipping hammers. Represented by R. T. Scott, G. C. Wilson, H. H. Hendricks, C. B. Ross and Fred Passino.

Ingersoll-Rand Company, New York, N. Y.—Little David drills and riveters, Crown chipping hammers, Imperial chipping hammers, Tell-tale motors, short stroke riveters and holders on. Represented by Charles R. Hewitt.

Marvin & Casler Company, Canastota, N. Y.—Offset boring head. Represented by E. T. Jones, Oneida, N. Y.

National Machinery Company, Tiffin, Ohio.—1½ in. single bolt cutter, motor drive and die grinder, motor drive, belt cutter heads. Represented by K. L. Ernest and Charles Harmon, Jr.

National Tool Company, Cleveland, Ohio.—Milling cutters, counter borers and special tools. Represented by E. A. Noll, H. A. Duetemeyer, J. L. Holstein and J. P. Jones.

Norton Company, Worcester, Mass.—Grinding wheels and miscellaneous material. Represented by H. J. Eckstedt and J. W. Horne.

Racine Tool & Machine Company, Racine, Wis.—Metal cutting machines. Represented by J. M. Jones, W. L. Candee and Fred Thoennes.

Ryerson & Son, Joseph T., Chicago.—Drills and boring bars. Represented by H. C. Williamson and C. E. Pynchon.

Skinner Chuck Company, New Britain, Conn.—Drill and lathe chucks, drill press vises, arbors and planer chucks. Represented by W. S. Rard.

Van Dorn Electric Tool Company, Cleveland, Ohio.—Electrically-operated portable drills, reamers and grinders. Represented by George Stoiber.

Weaver Manufacturing Company, Springfield, Ill.—Weaver roller jaw drill chucks, Weaver auto twin jack. Represented by C. F. Hodgson and J. P. Neerup.

Whitman & Barnes Manufacturing Company, Akron, Ohio.—Drills, reamers and wrenches. Represented by A. O. Wange.

#### MEETINGS AND CONVENTIONS.

*The following list gives names of secretaries, dates of next or regular meetings, and places of meeting.*

AIR BRAKE ASSOCIATION.—F. M. Nellis, 53 State St., Boston, Mass.

AMERICAN ASSOCIATION OF DEMURRAGE OFFICERS.—A. G. Thomason, Boston, Mass. Convention, May 19, 1914, St. Louis.

AMERICAN ASSOCIATION OF GENERAL PASSENGER AND TICKET AGENTS.—W. C. Hope, New York. Annual meeting, October 14-15, Philadelphia, Pa.

AMERICAN ASSOCIATION OF FREIGHT AGENTS.—R. O. Wells, East St. Louis, Ill.

AMERICAN ASSOCIATION OF RAILROAD SUPERINTENDENTS.—E. H. Harman, St. Louis, Mo.; 3d Friday of March and September.

AMERICAN ELECTRIC RAILWAY ASSOCIATION.—H. C. Donecker, 29 W. 39th St., New York.

AMERICAN ELECTRIC RAILWAY MANUFACTURERS' ASSOC.—H. G. McConaughy, 165 Broadway, New York. Meetings with Am. Elec. Ry. Assoc.

AMERICAN RAILWAY ASSOCIATION.—W. F. Allen, 75 Church St., New York. Next meeting, November 19, 1913, Chicago.

AMERICAN RAILWAY BRIDGE AND BUILDING ASSOCIATION.—C. A. Lichty, C. & N. W., Chicago. Convention, October 21-24, 1913, Montreal.

AMERICAN RAILWAY ENGINEERING ASSOCIATION.—E. H. Fritch, 900 S. Michigan Ave., Chicago.

AMERICAN RAILWAY MASTER MECHANICS' ASSOCIATION.—J. W. Taylor, Old Colony building, Chicago.

AMERICAN RAILWAY TOOL FOREMEN'S ASSOCIATION.—A. R. Davis, Central of Georgia, Macon, Ga.

AMERICAN SOCIETY FOR TESTING MATERIALS.—Prof. E. Marburg, University of Pennsylvania, Philadelphia, Pa.

AMERICAN SOCIETY OF CIVIL ENGINEERS.—C. W. Hunt, 220 W. 57th St., New York; 1st and 3d Wed., except June and August, New York.

AMERICAN SOCIETY OF ENGINEERING CONTRACTORS.—J. R. Wenlinger, 11 Broadway, New York; 2d Tuesday of each month, New York.

AMERICAN SOCIETY OF MECHANICAL ENGINEERS.—Calvin W. Rice, 29 W. 39th St., New York.

AMERICAN WOOD PRESERVERS' ASSOCIATION.—F. J. Angier, B. & O., Baltimore, Md. Next convention, January 20-22, 1914, New Orleans, La.

ASSOCIATION OF AMERICAN RAILWAY ACCOUNTING OFFICERS.—C. G. Phillips, 143 Dearborn St., Chicago. Annual meeting, May 28, Atlantic City, N. J.

ASSOCIATION OF RAILWAY CLAIM AGENTS.—J. R. McSherry, C. & E. I., Chicago.

ASSOCIATION OF RAILWAY ELECTRICAL ENGINEERS.—Jos. A. Andreucetti, C. & N. W. Ry., Chicago. Annual convention, October 18-24, Chicago.

ASSOCIATION OF RAILWAY TELEGRAPH SUPERINTENDENTS.—P. W. Drew, 112 West Adams St., Chicago.

ASSOCIATION OF TRANSPORTATION AND CAR ACCOUNTING OFFICERS.—G. P. Conard, 75 Church St., New York.

ASSOCIATION OF WATER LINE ACCOUNTING OFFICERS.—W. R. Evans, Chamber of Commerce, Buffalo, N. Y. Annual meeting, October 8, Philadelphia, Pa.

BRIDGE AND BUILDING SUPPLY MEN'S ASSOCIATION.—H. A. Neally, Joseph Dixon Crucible Co., Jersey City, N. J. Meeting with American Railway Bridge and Building Association.

CANADIAN RAILWAY CLUB.—James Powell, Grand Trunk Ry., Montreal, Que.; 2d Tuesday in month, except June, July and Aug., Montreal.

CANADIAN SOCIETY OF CIVIL ENGINEERS.—Clement H. McLeod, 413 Dorchester St., Montreal, Que.; Thursday, Montreal.

CAR FOREMEN'S ASSOCIATION OF CHICAGO.—Aaron Kline, 841 North 50th Court, Chicago; 2d Monday in month, Chicago.

CENTRAL RAILWAY CLUB.—H. D. Vought, 95 Liberty St., New York; 2d Thurs. in Jan. and 2d Fri. in March, May, Sept., Nov., Buffalo, N. Y.

CIVIL ENGINEERS' SOCIETY OF ST. PAUL.—L. S. Pomeroy, Old State Capitol building, St. Paul, Minn.; 2d Monday, except June, July, August and September, St. Paul.

ENGINEERS' SOCIETY OF PENNSYLVANIA.—E. R. Dasher, Box 704, Harrisburg, Pa.; 1st Monday after 2d Saturday, Harrisburg, Pa.

ENGINEERS' SOCIETY OF WESTERN PENNSYLVANIA.—E. K. Hiles, Oliver building, Pittsburgh; 1st and 3d Tuesday, Pittsburgh, Pa.

FREIGHT CLAIM ASSOCIATION.—Warren P. Taylor, Richmond, Va.

GENERAL SUPERINTENDENTS' ASSOCIATION OF CHICAGO.—E. S. Koller, 226 W. Adams St., Chicago; Wed. preceding 3d Thurs., Chicago.

INTERNATIONAL RAILWAY CONGRESS.—Executive Committee, 11, rue de Louvain, Brussels, Belgium. Convention, 1915, Berlin.

INTERNATIONAL RAILWAY FUEL ASSOCIATION.—C. G. Hall, 922 McCormick building, Chicago.

INTERNATIONAL RAILWAY GENERAL FOREMEN'S ASSOCIATION.—Wm. Hall, 829 West Broadway, Winona, Minn.

INTERNATIONAL RAILROAD MASTER BLACKSMITHS' ASSOCIATION.—A. L. Woodworth, Lima, Ohio. Annual meeting, August 18, Richmond, Va.

MAINTENANCE OF WAY & MASTER PAINTERS' ASSOCIATION OF THE UNITED STATES AND CANADA.—W. G. Wilson, Lehigh Valley, Easton, Pa.

MASTER BOILER MAKERS' ASSOCIATION.—Harry D. Vought, 95 Liberty St., New York.

MASTER CAR BUILDERS' ASSOCIATION.—J. W. Taylor, Old Colony building, Chicago.

MASTER CAR AND LOCOMOTIVE PAINTERS' ASSOC. OF U. S. AND CANADA.—A. P. Dane, B. & M., Reading, Mass. Annual meeting, September 9-12, Ottawa, Can.

NATIONAL RAILWAY APPLIANCE ASSOC.—Bruce V. Crandall, 537 So. Dearborn St., Chicago. Meetings with Am. Ry. Eng. Assoc.

NEW ENGLAND RAILROAD CLUB.—W. E. Cade, Jr., 683 Atlantic Ave., Boston, Mass.; 2d Tuesday in month, except June, July, Aug. and Sept., Boston.

NEW YORK RAILROAD CLUB.—H. D. Vought, 95 Liberty St., New York; 3d Friday in month, except June, July and August, New York.

NORTHERN RAILROAD CLUB.—C. L. Kennedy, C. M. & St. P., Duluth, Minn.; 4th Saturday, Duluth.

PEORIA ASSOCIATION OF RAILROAD OFFICERS.—M. W. Rotchford, Union Station, Peoria; 2d Thursday.

RAILROAD CLUB OF KANSAS CITY.—C. Manlove, 1008 Walnut St., Kansas City, Mo.; 3d Friday in month, Kansas City.

RAILWAY BUSINESS ASSOCIATION.—Frank W. Noxon, 2 Rector St., New York. Annual dinner, second week in December, 1913, New York.

RAILWAY CLUB OF PITTSBURGH.—J. B. Anderson, Penna. R. R., Pittsburgh, Pa.; 4th Friday in month, except June, July and August, Pittsburgh.

RAILWAY ELECTRICAL SUPPLY MANUFACTURERS' ASSOC.—J. Scribner, 1021 Monadnock Block, Chicago. Meetings with Assoc. Ry. Elec. Engrs.

RAILWAY FIRE PROTECTION ASSOCIATION.—C. B. Edwards, Mobile & Ohio, Mobile, Ala. Next meeting, October 7, Chicago.

RAILWAY GARDENING ASSOCIATION.—J. S. Butterfield, Lee's Summit, Mo. Next meeting, August 12-15, Nashville, Tenn.

RAILWAY DEVELOPMENT ASSOCIATION.—W. Nicholson, Kansas City Southern, Kansas City, Mo.

RAILWAY SIGNAL ASSOCIATION.—C. C. Rosenberg, Bethlehem, Pa. Convention, October 14, Nashville, Tenn.

RAILWAY STOREKEEPERS' ASSOCIATION.—J. P. Murphy, Box C, Collinwood, Ohio.

RAILWAY SUPPLY MANUFACTURERS' ASSOC.—J. D. Conway, 2135 Oliver bldg., Pittsburgh, Pa. Meetings with M. M. and M. C. B. Assocs.

RAILWAY TEL. AND TEL. APPLIANCE ASSOC.—W. E. Harkness, 284 Pearl St., New York. Meetings with Assoc. of Ry. Teleg. Sups.

RICHMOND RAILROAD CLUB.—F. O. Robinson, Richmond, Va.; 2d Monday except June, July and August.

ROADMASTERS' AND MAINTENANCE OF WAY ASSOCIATION.—L. C. Ryan, C. & N. W., Sterling, Ill. Convention, September 8-12, 1913, Chicago.

ST. LOUIS RAILWAY CLUB.—B. W. Frauenthal, Union Station, St. Louis, Mo.; 2d Friday in month, except June, July and Aug., St. Louis.

SIGNAL APPLIANCE ASSOCIATION.—F. W. Edmonds, 3868 Park Ave., New York. Meetings with annual convention Railway Signal Association.

SOCIETY OF RAILWAY FINANCIAL OFFICERS.—C. Nyquist, La Salle St. Station, Chicago.

SOUTHERN ASSOCIATION OF CAR SERVICE OFFICERS.—E. W. Sandwich, A. & W. P. Ry., Montgomery, Ala.

SOUTHERN & SOUTHWESTERN RAILWAY CLUB.—A. J. Merrill, Grant bldg., Atlanta, Ga.; 3d Thurs., Jan., March, May, July, Sept., Nov., Atlanta.

TOLEDO TRANSPORTATION CLUB.—J. G. Macomber, Woolson Spice Co., Toledo, Ohio; 1st Saturday, Toledo.

TRACK SUPPLY ASSOCIATION.—W. C. Kidd, Ramapo Iron Works, Hillsburn, N. Y. Meeting with Roadmasters' and Maintenance of Way Association.

TRAFFIC CLUB OF CHICAGO.—W. H. Wharton, La Salle Hotel, Chicago.

TRAFFIC CLUB OF NEW YORK.—C. A. Swope, 290 Broadway, New York; 1st Tuesday in month, except June, July and August, New York.

TRAFFIC CLUB OF PITTSBURGH.—D. L. Wells, Erie, Pittsburgh, Pa.; meetings monthly, Pittsburgh.

TRAFFIC CLUB OF ST. LOUIS.—A. F. Versen, Mercantile Library building, St. Louis, Mo. Annual meeting in November. Noonday meetings October to May.

TRAIN DISPATCHERS' ASSOCIATION OF AMERICA.—J. F. Mackie, 7042 Stewart Ave., Chicago.

TRANSPORTATION CLUB OF BUFFALO.—J. M. Sells, Buffalo; first Saturday after first Wednesday.

TRANSPORTATION CLUB OF DETROIT.—W. R. Hurley, L. S. & M. S., Detroit, Mich.; meetings monthly.

TRAVELING ENGINEERS' ASSOCIATION.—W. O. Thompson, N. Y. C. & H. R., East Buffalo, N. Y. Annual meeting, August, 1913, Chicago.

UTAH SOCIETY OF ENGINEERS.—R. B. Ketchum, University of Utah, Salt Lake City, Utah; 3d Friday of each month, except July and August.

WESTERN CANADA RAILWAY CLUB.—W. H. Rosevear, P. O. Box 1707, Winnipeg, Man.; 2d Monday, except June, July and August.

WESTERN RAILWAY CLUB.—J. W. Taylor, Old Colony building, Chicago; 3d Tuesday of each month, except June, July and August.

WESTERN SOCIETY OF ENGINEERS.—J. H. Warder, 1735 Monadnock Block, Chicago; 1st Monday in month, except July and August, Chicago.

## Traffic News.

A new Texas cotton tariff abolishing the Galveston-Houston differential and applying continuous short line mileage has been submitted to the Texas railroad commission by representatives of the Texas railroads interested.

President Pennington of the Minneapolis, St. Paul & Sault Ste. Marie, in speaking of the crop outlook in the northwest said, "We do not expect a crop as large as the one last year in North Dakota. Minnesota will do better; we will get more grain to haul from our Minnesota stations relatively."

A bill has been introduced in the United States House of Representatives providing for the establishment of experimental farms in each county and parish in each state of the union. The bill calls for an appropriation of \$10,000,000, to be expended under the direction of the secretary of agriculture.

Representative Kahn of California has introduced into the lower house of Congress an amendment to the laws relating to bills of lading, providing that all actions or suits brought to recover loss under a bill of lading shall be begun within one year after the goods covered are damaged or lost.

The two-cent passenger fare and the new freight rates reduced by from 5 to 40 per cent., which were sustained by the Supreme Court in its recent decision in the Minnesota rate case, became effective at midnight, July 20. Corresponding reductions in rates were made at the same time to several cities just across the state line.

The Missouri Public Service Commission has estimated that the costs in the Missouri state rate litigation will amount to approximately \$30,960, which will be paid by the 13 roads against which the Supreme Court has just decided the case. Approximately \$20,000 was expended for printing the records in the case, and the balance was for stenographic services and court fees.

In accordance with the orders of the Interstate Commerce Commission, the roads running from the Lakes to the Pittsburgh and Wheeling districts have equalized their rates on iron ore, making the rate 88 cents to both districts. This is an increase of 28 cents in the rate to the Wheeling district and a decrease of eight cents in the rate to the Pittsburgh district. This action has called forth a protest both from Pittsburgh steel interests and Wheeling steel men.

After September 1 the Pennsylvania Railroad will discontinue its free delivery of freight in both Washington and Baltimore. The free delivery of freight in Baltimore was established in 1870 as a temporary expedient. In Washington a free delivery of certain classes of shipments began in 1883 as a temporary plan to relieve the serious congestion which had developed at local terminals. The Pennsylvania had proposed to discontinue the free delivery in Washington, but the Interstate Commerce Commission, in a recent decision, held that the railroad could not discontinue this service in Washington while continuing it in Baltimore.

As suggested in the Interstate Commerce Commission's report on the New England situation, the Commission is now waiting a special investigation into the rate situation of the Boston & Maine. The B. & M. is at present engaged in preparing schedules of new rates which it proposes to submit to the commission which are understood to be materially higher than those now in effect. It is understood that one of the grounds upon which the B. & M. will attempt to justify the proposed increases is that the additional revenue is needed and will be used to bring the physical condition of the property up to the standard which the commission itself recognizes is the proper one to maintain.

### The Railroad "Rate Problem" Epitomized.

The Buffalo Courier, printing a recent news item, gets the whole of a 24-line paragraph into the heading, as follows: "Roads Are Pigs, Say the Pig Iron Men; Virginia Shippers Claim Selfish Rate Discrimination." The report goes on: Pig iron producers in Virginia have filed a complaint with the Interstate Commerce Commission against the Southern Railway, the Chesapeake & Ohio, the Norfolk & Western, the Pennsylvania and others, alleging that under the rates now in force, they

are handicapped in reaching some eastern markets and entirely prevented from reaching others. Statistics are given showing that the Pennsylvania Railroad, in particular, receives the largest portion of the rate, and that in some instances the rates to eastern points are 20 per cent. higher than from Ohio, New York, and other states.

### The Oats Crop.

Oats are now being cut in Missouri and Kansas. Iowa, the premier oats state this year, will begin to cut that crop within a week. The last week in July is usually the season in which this, the second largest cereal crop, is cut in the chief states extending from the Atlantic seaboard west to the Rocky mountains. This year Iowa has an area of 12.7 per cent. of the total United States acreage, and should on these 5,000,000 acres get from 150,000,000 to 175,000,000 bus.

Illinois ranks next with 4.2 per cent. of the entire area of 38,341,000 acres. Dry conditions in central Illinois will cut down that state's yield somewhat, but elsewhere the prospect is fine according to some reports of field observers.

Since the government's report on July 9 the indicated yield of 1,000,000,000 bus. has generally been accepted as the most probable forecast. The condition of 76.3 on July 1 was not high, however, and a lower total was not at all surprising. Since June 30 the December price of oats at Chicago, which is the best price index of the trade estimate for crop prospects, has dropped from 44 to 40 cents and under. That is still, however, 5 or 6 cents higher than last year's quotation at this date, and is taken to mean that the billion bushel yield, which is 387,000,000 bus. below last year's final, is probably not an over-estimate.

At these higher prices this season's oats might be expected to move early in August with a good deal of freedom. But on account of the big yield of 1912 there is no such emptiness in bins and other stocks as followed the short crop of 92,000,000 bus. in 1911. A rather slow selling is looked for in the early part of the season. Owing also to late hay shortage growers are apt to hold on to their oats for better prices.—Wall Street Journal.

### INTERSTATE COMMERCE COMMISSION.

The commission has further suspended from July 25 until January 25 the supplement to the tariff of the Chicago, Milwaukee & St. Paul, which proposed to increase the rates on wheat, flour, corn, rye, oats and barley, from Spencer, Ia., and other points to Sioux City, Ia.

The commission has suspended from July 21 until November 18 the supplement to the tariff of the Baltimore & Ohio Chicago Terminal Railroad, which would advance rates on crushed stone from McCook and Thornton, Ill., to various points in Indiana and Michigan. This was to have been accomplished by the cancellation of through rates and the application thereafter of combinations of locals. For example, the present joint through rate on the traffic involved is 35½ cents per net ton from McCook, Ill., to Munster, Ind., and the proposed rate 55 cents per net ton, resulting in an advance of 19½ cents per net ton.

W. A. Gardner, president of the Chicago & North Western, was the principal witness for his road at a hearing before Examiner Settle of the Interstate Commerce Commission, at Chicago last week, involving advances in the rates on ore in the iron region of Wisconsin and Michigan. He testified he had given personal attention to the rate situation in the iron country, and that he himself had ordered the advance in rates. He stated that the service of the North Western between the mines and docks was primarily a terminal service, and that because of the short hauls the switching expense was out of all proportion to the line haul. The iron region, he said, is like one vast yard that requires an unusually large number of employees, who are receiving 45 per cent. higher wages than in 1900, while their work has become specialized so that more are now required for the same service. From 1909 to 1912 the company had spent \$515,000 for side tracks, \$6,000,000 for cars and \$4,000,000 for docks to handle this ore traffic in order to give better service to the shippers. Mr. Gardner was followed by E. D. Brigham, assistant freight traffic manager, who covered more in detail the points made by the president.

**Reparation Awarded.**

*Victor Manufacturing Company et al v. Southern Railway, Enrarea Manufacturing Company et al v. Louisville & Nashville et al. Opinion by Commissioner Merrill:*

The complainant asks for reparation on shipments of coal from the coal regions in eastern Tennessee and other coal regions grouped therewith, made before the last reduction in the rates between the points in question. The commission decided that at the time when the shipments moved the rates were excessive to the extent of ten cents a ton, and awarded reparation on that basis. (27 I. C. C., 661.)

*Washington Milling Company v. Norfolk & Western Railway, Company et al. Opinion by the commission:*

The rate of 19 cents per 100 lbs. for the transportation of grain products, in carloads, from Washington Court House, Ohio, to points on the Norfolk & Western east of Kenova, W. Va., to and including Bluefield, W. Va., found unreasonable to the extent it exceeds 15 cents per 100 lbs. and that rate was prescribed for the future. (27 I. C. C., 546.)

**Complaint Dismissed.**

*Lesser-Goldman Cotton Company et al. v. St. Louis, Iron Mountain & Southern et al. Opinion by the commission:*

The complainants seek reparation for an alleged unreasonable and unjustly discriminatory rate paid on shipments of "concentrated" cotton from Arkansas points to Boston, Mass., and other eastern points. The commission decided that the record fails to show that the rate in issue was unreasonable or unjustly discriminatory at the time it was charged. (27 I. C. C., 496.)

*Hampton Manufacturing Company v. Old Dominion Steamship Company, et al. Opinion by the commission:*

The commission decided that charges for the transfer in transit, at New York, of certain less-than-carload shipments of iron columns from Hampton, Va., to Kings Park, Long Island, N. Y., and from Kings Park to Hampton on return movements, were not shown to have been unreasonable. Reparation was denied. (27 I. C. C. 666.)

*Hennepin Paper Company, et al. v. Northern Pacific, et al. Opinion by Commissioner Clements:*

The commission decided that the application on news print paper of lower rates from New England milling points to Central Freight Association territory and from Wisconsin milling points to southwestern points than from Little Falls and Sartell, Minn., to the same destinations, was not shown to constitute unjust discrimination under section 3 of the act to regulate commerce. (27 I. C. C. 699.)

*California Pole & Piling Company, et al., v. Southern Pacific. Opinion by the commission:*

In this case the complainant contends that the defendant charged unreasonable rates for the transportation of poles and piling in carloads from points in Oregon to points in California. The rate charged exceeded by one dollar per ton the lumber rates in force between the same points. The commission decided that the rates charged were not shown to have been unreasonable. (27 I. C. C. 670.)

**Joint Rates Over Interurban Electric Lines.**

*Louisville Board of Trade et al. v. Indianapolis, Columbus & Southern Traction Company et al. Opinion by Commissioner Harlan:*

The complainant asks that through routes and joint rates be established for less than carload freight between Louisville and points near Indianapolis over connecting interurban electric lines. These interurban lines now do a large passenger business and some perishable freight business. They claim that freight traffic will injure their passenger business and would result in severe congestion. They also point out that freight now moves between any of the points in question over the lines of steam railroads. The complainant showed that the electric service would be much better than the steam railroads for package freight, as it would be more expeditious. The complainant asked that the through rates over the interurban lines should

not exceed those over the steam railroads, both to points intermediate to Indianapolis and to points beyond. The commission decided that the defendants should grant the relief sought by the complainant and ordered them to establish through routes for package freight between the points desired. The commission also ordered the defendants to establish joint rates between Louisville and points intermediate to Indianapolis which should be no higher than the rates charged by the Pennsylvania Lines West. Joint rates were not prescribed to points beyond Indianapolis as the commission decided that the combination of local rates on Indianapolis would be reasonable. (27 I. C. C., 499.)

**Wheat Rates Reduced.**

*Federal Milling Company v. Minneapolis, St. Paul & Sault Ste. Marie, et al. Opinion by Commissioner Clements:*

The aggregate rate on wheat, all rail, from Minneapolis to New York, via Chicago and Lockport, N. Y., is 26 cents and on flour 25 cents. The aggregate rate on this wheat milled in transit at Lockport is 27.2 cents. The rate on wheat was held to be unreasonable to the extent that it exceeds the rate on flour, and the defendant carriers were required to maintain on wheat milled at Lockport transit rates and regulations on the same relative basis as proposed by them in *Board of Trade of the City of Chicago v. C. & A. R. R. Co.*, 21 I. C. C., 530, mentioned in the *Railway Age Gazette* of July 18, page 125. (27 I. C. C. 696.)

**Rates from St. Louis to Kansas Points Reduced.**

*State of Kansas, et al., v. Atchison, Topeka & Santa Fe, et al. Opinion by Commissioner Clements:*

The commission decided that the class and commodity rates from St. Louis to interior Kansas points were unreasonable and unduly discriminatory, and prescribed reasonable maximum class rates to Topeka, Salina, Hutchinson, Wichita, Dodge City, and Goodland as representative destinations; the commodity rates to these points and both class and commodity rates to other points in interior Kansas were left to be readjusted by the carriers relatively.

It is of secondary importance whether the present unreasonable rate adjustment from St. Louis to points in interior Kansas is due to the existence of the Missouri river as a basing line, or to some other method of making rates. The primary question is whether these rates, in whatever manner constructed, are reasonable and free from undue discrimination. The manner of their construction is pertinent in this proceeding only in the opportunity afforded to the commission more minutely to examine the through rate by consideration also of its constituent parts.

In considering the reasonableness of a comprehensive rate fabric such as the one in question, the commission must look more to the adjustment as a whole than to individual comparisons, as much can be ostensibly proved by either party to controversies before the commission by care in the selection of individual rates convenient for the purpose. Such rates are ever present in tariffs and cover a wide range. (27 I. C. C. 673.)

**Rates on Butter and Eggs Not Increased.**

*In re investigation and suspension of advances in rates by carriers for the transportation of butter and eggs from Topeka, Kan., to Memphis, Tenn., and other points. Opinion by Commissioner Harlan:*

The commission found that the respondent had not shown sufficient justification for the proposed withdrawal of the present commodity rates from Topeka and the imposition of class rates; and decided that the present rates are just and reasonable and should not be exceeded for the future. (27 I. C. C. 692.)

**Duluth Discriminated Against.**

*Commercial clubs of the city of Duluth v. Baltimore & Ohio, et al. Opinion by Commissioner Harlan:*

The complainant contends that the rail-and-lake rates to Duluth, Minn., from points east of the Indiana-Illinois State line are unreasonably high in themselves and are unjustly dis-

## Railway Officers.

### Executive, Financial and Legal Officers.

B. S. Barker has been appointed vice-president and general manager of the Gainesville & Northwestern, with headquarters at Gainesville, Ga.

T. S. Ford has been appointed auditor of the San Antonio, Uvalde & Gulf, with headquarters at San Antonio, Tex., succeeding G. H. Winsor, who retains the position of general freight and passenger agent.

Charles S. Mellen, who recently resigned the presidency of the Boston & Maine and the Maine Central, has resigned also as president of the New York, New Haven & Hartford and subsidiary lines, to become effective on the election of his successor.

C. W. Jones, vice-president and general manager of the Chicago, Rock Island & Gulf, has been elected president and general manager, with headquarters at El Reno, Okla. H. U. Mudge, whom Mr. Jones succeeds as president, has been elected chairman of the board of directors.

L. H. Long, assistant general manager of the Southern Pacific of Mexico, and the Arizona Eastern at Tucson, Ariz., has been appointed a vice-president of both these roads, and J. C. McClure, assistant general manager at Tucson, has been appointed assistant to president of both roads, with headquarters at Tucson.

The jurisdiction of Alexander Robertson, assistant to the president of the Missouri Pacific and the St. Louis, Iron Mountain & Southern, and of J. M. Johnson, vice-president in charge of traffic of those roads, has been extended over the Western Pacific and the Denver & Rio Grande, with headquarters at St. Louis, Mo.

John Quincy Van Winkle, whose appointment as assistant to Vice-president J. J. Bernet, of the Cleveland, Cincinnati, Chicago & St. Louis, has already been announced in these

criminary in their relation to the rates from the same territory to Chicago. Also that the present rates on through rail-and-lake traffic to Duluth from trunk line territory are unreasonable and unjustly discriminatory as compared with rates from the same territory to Chicago. The commission decided that the present scale of rail-and-lake class rates to Duluth from Trunk Line and Central Freight Association territories was excessive and prescribed reasonable rates for the future; also that any scale of rail-and-lake rates to Duluth in excess of the rail-and-lake rates to Chicago from trunk line territory is unjustly discriminatory against Duluth. The carriers were ordered to remove this discrimination. The class rates to Duluth from all points east of the Indiana-Illinois state line were also found to be unreasonable and the carriers were ordered to reduce them so that they would bear about the same relation to the rates from New York, just prescribed for the future, as the present rates from those points bear to the present rates from New York to Duluth.

The spread between the Duluth rates and the Twin City rates is on a 15-cent scale. The commission found that there was an undue discrimination against Duluth in this narrow spread between its through rates on traffic from the east and its through rates to the Twin Cities on similar traffic. To remove this discrimination the commission prescribed for the future lower rates on through traffic to Duluth. The complainants contend that the tariff rates on rail-and-lake traffic to the northwest ought to break on its wharves instead of at the Twin Cities and that, in fairness to Duluth, the sum of the intermediate rates is the lowest rate adjustment that Minneapolis and St. Paul should have. The commission found that there was no good reason for requiring the carriers to break the rate on the Duluth wharves. Duluth cannot ask for anything more than reasonable rates and a reasonable relation of rates as between itself and the Twin Cities. To have rates break at a particular point is not an inherent rate right. And inasmuch as the rates to the northwest under the present adjustment break on the Twin Cities and not on Duluth, neither the through rates to the Twin Cities nor the general rate structure to the northwest will be disturbed by a readjustment of the factors on which the Twin City rates are based. In this manner Duluth may be given a more ample recognition of its natural advantages of location at the head of the lake. This it is clearly entitled to have. The commission found also that undue rate discrimination against towns in the vicinity of the Twin Cities, fourth section violations, and evasions and manipulations growing from the loose policing of transit privileges at Duluth existed. Although no order was entered in regard to those practices the carriers will be expected to submit revised tariffs by October 1, 1913, removing the discriminations. (27 I. C. C. 639.)

### COURT NEWS.

The Chicago, Rock Island & Pacific and Chicago Great Western, in behalf of all of the roads operating in Iowa, have filed a petition with the federal district court at Des Moines, asking an injunction to prevent the state railroad commission from enforcing the new law prescribing a passenger rate of 1½ cents per mile for state fairs and other meetings at which the attendance is 75,000 or over.

Judge Cushman, in the United States district court at Seattle, in a proceeding brought by Mary A. Meese against the Northern Pacific for \$75,000 for the death of her husband, has held that since the widow collected \$4,000 under the provisions of the state for a workingman's compensation fund, she is not entitled to any damages from the railroad or from the company which employed Meese. Meese was employed by a brewery and was killed while working on a spur track of the Northern Pacific to the brewery.

The attorney-general of Mississippi on July 22 filed a suit in the chancery court at Clarksville, Miss., against the Illinois Central and the Yazoo & Mississippi Valley railroads, alleging an illegal merger under the anti-trust laws and asking penalties approximating \$50,000,000. The bill asks for a dissolution of the merger, forfeiture of the charter of the Y. & M. V., ousting of the Illinois Central from the state, sale of the Y. & M. V. securities held by the I. C., and the appointment of separate receivers for the two roads.



J. O. Van Winkle.

columns, was born January 16, 1851, in Madison county, Ind. He was educated in the common schools at Anderson, Ind., and began railway work in 1861 with the Indianapolis, Pittsburgh & Cleveland (now a part of the Big Four) as messenger and general utility boy at Anderson, Ind. From 1865 to 1867 he was news agent on the road, and then until July, 1873, was clerk in the station at Anderson. The following five months he was agent at Pendleton, Ind., and from December, 1873, to 1877, was chief clerk in the superintendent's office. From the latter date to November, 1881, he was successively agent at Union City, Ind., general yardmaster at Indianapolis, Ind., and agent at Mattoon, Ill. He was then made trainmaster at Indianapolis; from December, 1882, to January, 1884, was agent at East St. Louis, Ill., and from January, 1884, to September, 1888, agent and division freight agent at Indianapolis. He was then from September, 1888, to January, 1892, superintendent. Mr. Van Winkle's service up to this time had been with the Cleveland, Columbus & Cincinnati, and its successor, the Cleveland, Cincinnati, Chicago & St. Louis, which road he left to become general superintendent of the Terminal Railroad Association of St. Louis. He returned to the Big Four in March, 1893, as general superintendent, and on May 1, 1906, was made assistant general manager. He was promoted to general manager of that road, the Peoria & Eastern and the Cincinnati

Northern, on October 1, 1906, which position he held at the time of his recent appointment as assistant to the vice-president, with headquarters at Cincinnati, Ohio, as above noted.

Arthur P. Foss, whose appointment as comptroller of the Maine Central, with headquarters at Portland, Maine, has been announced in these columns, was born on March 25, 1869, at Abbot, Maine, and was educated at Monson Academy, Monson, and at Maine Central Institute, Pittsfield. He began railway work in July, 1887, with the Maine Central, and has been in the continuous service of that road ever since. From October of the same year to March, 1892, he was freight clerk at Augusta, and then to October, 1899, was traveling auditor. He was appointed chief clerk in the accounting department on October 1, 1899, and in July, 1907, was made auditor of disbursements, remaining in that position until November, 1911, when he was promoted to assistant comptroller, which position he held at the time of his recent appointment as comptroller of the same road, as above noted.

#### Operating Officers.

C. J. Field has been appointed general manager of the Orangeburg Railway, in charge of operation and traffic, with headquarters at Orangeburg, S. C.

D. Van Hecke, trainmaster of the Rock Island lines at Haileyville, Okla., has been transferred to the Oklahoma division in a similar capacity, with headquarters at El Reno, Okla.

E. M. Costin, division superintendent of the Cleveland, Cincinnati, Chicago & St. Louis, at Cleveland, Ohio, has been appointed assistant general superintendent, with headquarters at Indianapolis, Ind.

S. W. Gibson, formerly superintendent of the Northern Illinois & Southern Wisconsin division of the Wells, Fargo & Company, and A. G. Eddy, heretofore superintendent of the Iowa division, have been appointed efficiency superintendents, with headquarters at Chicago, and will report to E. A. Stedman, vice-president and general manager.

D'Alton C. Coleman, general superintendent of the Manitoba division of the Canadian Pacific at Winnipeg, Man., has been appointed general superintendent of the Alberta division, succeeding A. Price, transferred, and C. Murphy, general superintendent of transportation at Montreal, has been appointed general superintendent of the Manitoba division, succeeding Mr. Coleman.

F. B. Sanford, chief dispatcher of the Missouri, Kansas & Texas, has been appointed trainmaster of the Cherokee division, succeeding F. P. Stocker, who has been transferred to the Choctaw division as trainmaster, both with headquarters at Muskogee, Okla. R. R. Farmer, trainmaster of the Choctaw division, has been transferred to the St. Louis division as trainmaster, with headquarters at Sedalia, Mo.

Timothy H. Sullivan has been appointed superintendent of the Iowa division of the Illinois Central, with office at Ft. Dodge, Iowa, succeeding Lawrence A. Downs, transferred. George E. Patterson succeeds Mr. Sullivan as superintendent of the Springfield division, with headquarters at Clinton, Ill. Joseph W. Hevron is appointed trainmaster of the Chicago, Bloomington, Pontiac and Tracy districts, and Gilman Line, with office at Kankakee, Ill., in place of Mr. Patterson. Effective July 15.

C. O. Jenks, general superintendent of the Central District of the Great Northern, with office at Great Falls, Mont., has been appointed general superintendent of the Lake district, with headquarters at Superior, Wis., succeeding J. H. Taylor, deceased. Mr. Jenks is succeeded by F. S. Elliott, heretofore assistant general superintendent of the Western district. J. H. O'Neill takes the place of Mr. Elliott at Spokane, Wash. M. Nicholson is appointed assistant general superintendent of the Central district, with headquarters at Great Falls, Mont. W. R. Smith, superintendent of the Kalispell division, with office at Whitefish, Mont., is appointed superintendent of the Cascade division, with headquarters at Everett, Wash., succeeding J. H. O'Neill. John C. Sesser, assistant engineer maintenance of way at St. Paul, Minn., succeeds Mr. Smith as superintendent of the Kalispell division. J. Lindsay, superintendent of the Sioux City

division, is appointed superintendent of the Fergus Falls division, with headquarters at Melrose, Minn., in place of M. Nicholson. G. E. Votaw, trainmaster at Spokane, Wash., succeeds Mr. Lindsay as superintendent of the Sioux City division, with office at Sioux City, Iowa. Effective July 20.

John C. Sesser, who has been appointed superintendent of the Kalispell division of the Great Northern, with headquarters at Whitefish, Mont., was born on August 20, 1873, at St. Joseph,



J. C. Sesser.

Mich. He was educated at Michigan State College, and at Lehigh University, receiving the degree of civil engineer. From June, 1896, to February of the following year he was draftsman with the Allentown Rolling Mill Company, Allentown, Pa., and then entered railway service. He was consecutively instrument man and resident engineer on the Chicago & North Western until April, 1898, and then to December of the following year was resident engineer of the Union Pacific. In November, 1900, he became chief engineer of the Olaa Plantation, Olaa, Hawaii. From June, 1901, to November of the following year he was resident engineer of the Chicago, Milwaukee & St. Paul, and then, to May, 1903, was chief engineer of the Iowa & St. Louis. He was resident engineer and engineer of maintenance of way of the Missouri district of the Chicago, Burlington & Quincy from May, 1903, to April, 1907, and then to December, 1909, was vice-president of W. K. Kenly & Co., and contracting engineer of the Walsh Construction Company. In December, 1909, he was appointed assistant engineer maintenance of way of the Great Northern, at St. Paul, Minn., which position he held at the time of his recent appointment as superintendent of the Kalispell division of the same road, as above noted.

#### Traffic Officers.

M. F. Hogan has been appointed assistant commercial agent of the Chicago, Milwaukee & St. Paul at Davenport, Ia.

R. S. Trumbull has been appointed agricultural agent of the El Paso & Southwestern System and the Morenci Southern, with headquarters at El Paso, Texas.

W. W. Croxton, general passenger agent of the Norfolk Southern, at Norfolk, Va., has been appointed general passenger agent of the Atlanta, Birmingham & Atlantic, with headquarters at Atlanta, Ga., succeeding W. H. Leahy.

A. C. Kessell has been appointed freight and ticket agent of the Pennsylvania Lines at Dresden, Ohio, in place of M. F. Ater, transferred. J. E. Kessell has been appointed freight and ticket agent at South Zanesville, Ohio, succeeding A. C. Kessell.

H. S. Leard, division passenger agent of the Seaboard Air Line, at Raleigh, N. C., has been appointed general passenger agent of the Norfolk Southern, with headquarters at Norfolk, Va., succeeding W. W. Croxton, resigned to go to another company.

Harry F. Voss has been appointed traveling freight agent of the Cincinnati, New Orleans & Texas Pacific and John P. O'Gallagher has been appointed soliciting freight agent, both with headquarters at Atlanta, Ga. L. F. Malum has been appointed soliciting freight agent with headquarters at Jacksonville, Fla.

H. A. Howe has been appointed commercial agent of the Illinois Central, with office at Buffalo, N. Y., succeeding H. P. Hewes, resigned to accept service with another company, and J. E. Whitney has been appointed contracting freight agent, with office at New York, succeeding S. E. Frank, promoted.

Charles Beverley Foster, whose appointment as assistant passenger traffic manager, Eastern Lines of the Canadian Pacific, with headquarters at Montreal, Que., has been announced in these columns, was born on September 30, 1871, at Kingston, Kings county, New Brunswick, and was educated in the public schools. He entered the service of the Canadian Pacific on April 1, 1891, as a stenographer in the passenger department at St. John, and has been in the continuous service of that road ever since. In September, 1893, he was appointed traveling passenger agent, and in August, 1899, became chief clerk in the passenger department, remaining in that position until February, 1902, when he was appointed district passenger agent at St. John. He was transferred in the same capacity in November, 1904, to Toronto, Ont., and in September, 1908, became assistant general passenger agent at Vancouver, B. C. On November 1, 1910, he was made general passenger agent at Winnipeg, Man., which position he held at the time of his appointment on July 1, 1913, as assistant passenger traffic manager, Eastern Lines, of the same road, with headquarters at Montreal, as above noted.

Carlos A. Hayes, whose appointment as general traffic manager of the Intercolonial and the Prince Edward Island railways, with headquarters at Moncton, N. B., has been announced in these columns, was born on March 10, 1865, at West Springfield, Mass., and was educated at Amherst College. He began railroad work in 1882, as a clerk in the freight accounting department of the Connecticut River Railroad. In November, 1884, he was appointed chief clerk in the freight accounting department and later was chief clerk in the general freight office of the Boston & Lowell, and the successor of both these roads, the Boston & Maine. He was general freight and passenger agent of the Central New England & Western, now a part of the Central New England, from November, 1890, to June, 1892, and then, to the following October, was division freight agent of the Philadelphia & Reading. From October, 1892, to June, 1896, he was the New England agent of the National Despatch Freight Line; then for about three years, was New England agent and acting general manager, and in July, 1899, was made manager of the same line. From April, 1902, to May of the following year he was manager of the National Despatch Great Eastern Line, and in May, 1903, was appointed assistant general freight agent of the Grand Trunk, remaining in that position until 1908, when he became general freight agent of the same road. On October 16, 1911, he was promoted to freight traffic manager of the Grand Trunk, which position he held at the time of his recent appointment as general traffic manager of the Intercolonial and the Prince Edward Island railways, as above noted.

#### Engineering and Rolling Stock Officers.

Clarence Curtis Blood has been appointed roadmaster of the Puget Sound division of the Northern Pacific at Seattle, Wash.

R. A. Cook, engineer track elevation of the Chicago & Alton, at Joliet, Ill., has been appointed valuation engineer of that road, with headquarters at Chicago.

M. W. Jones, trainmaster of the Guayaquil & Quito, has been appointed also superintendent of telegraph and telephone, with headquarters at Huigra, succeeding A. R. Morris resigned.

G. B. Owen, engineer maintenance of way of the Erie at Jersey City, N. J., having been granted six months' leave of absence, the duties of that position were taken over by the general manager's office on July 1.

W. N. Mitchell, for eight years the head of the railway department of the International Correspondence Schools at Chicago, has been appointed fuel supervisor of the Chicago Great Western, with office at Chicago.

James Edward Johnson, whose appointment as division engineer of the Pere Marquette, with office at Saginaw, Mich., has already been announced in these columns, was born August 24, 1883, at Tipton, Ind. He was educated at the Ohio State University, and began railway work February 1, 1905, with the Cincinnati, Hamilton & Dayton as rodman. From May 1 to September 1 of that year he was rodman and instrumentman on the Lake Shore & Michigan Southern, and then until January 15, 1906, he was with the Cleveland, Cincinnati, Chicago & St. Louis as masonry inspector and transitman. The following eight months he was with the Vandalia

as engineer of corps, and on September 1, 1906, he became assistant engineer of the Missouri Pacific and St. Louis, Iron Mountain & Southern. From February, 1907, to September 15, 1912, Mr. Johnson was division engineer of the Pere Marquette, resigning to become assistant eastern sales agent of the P. & M. Company at Chicago. He now returns to the Pere Marquette as division engineer, as above noted.

R. Q. Prendergast, who has been appointed mechanical superintendent of the Bangor & Aroostook, with headquarters at Milo Junction, Maine, as has been announced in these columns, was



R. Q. Prendergast.

educated in the high schools and at a business college. After serving his apprenticeship as machinist on the Baltimore & Ohio, at Benwood, W. Va., he was promoted to division foreman at Cameron, and then for a number of years was general foreman at most of the large shops of the same road, including the Mount Claire shop. He then went to the Cumberland Valley as general foreman at Chambersburg, Pa., and three years later was appointed general foreman of the Delaware & Hudson at Carbondale, Pa. He remained in that position for two years, and then for five years was division master mechanic on the Denver & Rio Grande at Pueblo, Colo. He left that road to go to the Cincinnati, Hamilton & Dayton as division master mechanic at Indianapolis, Ind., where he remained for one year, leaving that position to become mechanical superintendent of the Bangor & Aroostook, as above noted.

#### Purchasing Officers.

H. C. Pearce, general storekeeper of the Southern Pacific at San Francisco, Cal., has been appointed to the new position of general purchasing agent of the Seaboard Air Line, with headquarters at Norfolk, Va., in charge of both purchases and stores.

H. G. Cook has been appointed general storekeeper of the Southern Pacific, with headquarters at San Francisco, Cal., to succeed H. C. Pearce, resigned to accept position with another company; effective July 15.

A. A. Goodchild, auditor stores and mechanical accounts of the Canadian Pacific at Montreal, Que., has been appointed general storekeeper for lines east of Fort William, Ont., with office at Montreal, succeeding M. J. Power, deceased.

#### OBITUARY.

Gordon A. Aird, general agent of the freight department of the Atchison, Topeka & Santa Fe, died at his home in Chicago on July 15.

J. H. Taylor, general superintendent of the Lake district of the Great Northern, with headquarters at Superior, Wis., died at his residence in Duluth, Minn., on July 14, aged 51 years. Mr. Taylor began railway work in 1879 with the New York, Lake Erie & Western, with which road he remained until May, 1886, as clerk and operator at various stations. He was then until June 15, 1902, with the Erie & Wyoming Valley as train despatcher, chief despatcher and trainmaster. From the latter date to November, 1904, Mr. Taylor was connected with the Erie as division operator of the Erie division and division superintendent at Bradford, Pa., and Port Jervis, N. Y. He left the Erie to go to the Great Northern as superintendent of the Mesabe & Superior division at Superior, Wis. In September, 1909, he was promoted to general superintendent of the Central district, and in March, 1912, he was made general superintendent of the Lake district.



## Equipment and Supplies.

### LOCOMOTIVE BUILDING.

THE MIDLAND VALLEY has ordered 2 consolidation locomotives from the Baldwin Locomotive Works.

THE CENTRAL OF GEORGIA has ordered 4 Pacific type locomotives from the Baldwin Locomotive Works.

THE LIVE OAK, PERRY & GULF has ordered 1 ten-wheel locomotive from the Baldwin Locomotive Works.

THE COAL & COKE RAILWAY has ordered 2 consolidation locomotives from the Baldwin Locomotive Works.

THE INGRAM-DAY LUMBER COMPANY has ordered 1 ten-wheel locomotive from the Baldwin Locomotive Works.

THE BOSTON & ALBANY has ordered 4 six-wheel switching locomotives from the American Locomotive Company. These locomotives will be equipped with superheaters, will have 21 in. x 28 in. cylinders, 57 in. driving wheels, and in working order will weigh 170,000 lbs.

THE DELAWARE, LACKAWANNA & WESTERN has ordered 1 four-wheel switching locomotive from the American Locomotive Company. The dimensions of the cylinders will be 16 in. x 24 in.; the diameter of the driving wheels will be 46 in., and the total weight in working order will be 89,000 lbs.

### CAR BUILDING.

THE SOUTHERN RAILWAY is in the market for 1,500 freight cars.

THE SEABOARD AIR LINE has ordered 10 coaches from the Pressed Steel Car Company.

THE PENNSYLVANIA EQUIPMENT COMPANY, Philadelphia, Pa., is in the market for 1 second-hand combination passenger and baggage car.

THE EL PASO & SOUTHWESTERN is making inquiries for 3 steel coaches, 2 dining cars, 2 combination baggage and express cars and 1 combination baggage and mail car.

THE NEW YORK, NEW HAVEN & HARTFORD is said to be in the market for 100 coaches, 50 smoking cars, 10 combination baggage and mail cars and 10 combination baggage and smoking cars.

### IRON AND STEEL.

THE CHICAGO & EASTERN ILLINOIS has ordered 12,000 tons of rails from the Illinois Steel Company.

GENERAL CONDITIONS IN STEEL.—Manufacturers report that while there has been no perceptible increase in buying during the past week, more inquiries are coming in from consumers. It is estimated that incoming business, including the United States Steel Corporation as well as the independent companies, is at the rate of about 50 per cent. of shipments. This new business, with the old orders on the books, is keeping the mills operating slightly above 90 per cent. of maximum capacity. New orders are mostly for deliveries in the near future, which helps to sustain mill activity.

NEW PORT RAILWAY IN URUGUAY.—The Montevideo Port railway, inaugurated on May 16, runs from the main station of the Central Uruguay Railway around the port to the docks where the steamers tie up. The road is only a few miles long, but by establishing direct communication between the sea and land carriers, it represents a commercial link of the utmost importance. The docks are provided with traveling electric cranes of high power, and now that steamers are berthed at the docks and railway cars may be run to the water's edge alongside the steamers, the transshipment of cargo from railway car to steamer and vice versa may be effected without loss of time and at a minimum of cost.

## Supply Trade News.

The Roberts & Schaefer Company, Chicago, has received a contract from the Virginian Railway for a large 400-ton capacity, reinforced concrete, counterbalanced bucket (Holmen type) locomotive coaling station to be built immediately at Elmore, W. Va. The approximate contract price is \$30,000.

Edwin R. Rockwell, formerly president of the Guarantee Electric Company, Chicago, announces the formation of the Rockwell Electric Company, with office in the First National Bank building, Chicago. The firm will handle electrical machinery, and offers its services for electrical engineering in all branches.

The Southern California Edison Company has received permission from the California railroad commission to issue \$2,500,000 5 per cent. first mortgage bonds. Instead of selling these bonds now the company will pledge a portion of them as collateral for money which will be borrowed until the bonds can be sold on more favorable terms.

The Titan Copper Products Company, Inc., Buffalo, N. Y., maker of brass, bronze and aluminum castings, has been organized by Charles V. Slocum, who for the past six years has been engaged in introducing titanium to the steel and iron trade. The officers of the company are as follows: President, Charles V. Slocum; vice-president, A. N. Slocum; treasurer, W. W. Slocum, and general superintendent, Frank P. Lund.

L. C. Noble, vice-president of the Pittsburgh Spring & Steel Company, Pittsburgh, Pa., with office in Chicago, died at his home in Evanston, Ill., on July 19, after a brief illness. Mr. Noble was superintendent of motive power of the Houston & Texas Central for a number of years prior to 1890. In that year he became associated with the A. French Spring Company as western manager of sales. In 1902 he resigned that position to become vice-president of the Pittsburgh Spring & Steel Company.

### TRADE PUBLICATIONS.

AUTOMATIC VOLTAGE REGULATORS.—The General Electric Company, Schenectady, N. Y., has issued bulletin No. A4123, describing its automatic voltage regulators for the regulation of generator voltage. These regulators are made for use with both alternating and direct current. This bulletin supersedes the company's previous bulletin on this subject.

BOLT CUTTERS.—The National Machinery Company, Tiffin, Ohio, has published an illustrated booklet entitled Perfect Threads, describing its demonstrations of cutting threads on National bolt cutters which took place at the recent conventions of the American Railway Master Mechanics' Association and the Master Car Builders' Association at Atlantic City, N. J.

WATERPROOFING.—The Ceresit Waterproofing Company, Chicago, has issued an especially attractive booklet describing the use of Ceresit waterproofing paste for concrete work and many examples of structures on which it has been used. The booklet takes up the subject of waterproofing in detail, its origin, its uses and its advantages, giving a scientific explanation of the action of Ceresit, detailed reports of technical tests of its reliability and permanence, and a large number of specific records of its use, together with complete specifications.

BALDWIN LOCOMOTIVES.—Three bulletins of locomotive construction have been received from the Baldwin Locomotive Works, Philadelphia, Pa. Record No. 73, entitled "Recent Development of the Locomotive," contains a paper by George R. Henderson, consulting engineer of the Baldwin Locomotive Works, which was presented before the Franklin Institute last year. It covers the important developments in steam locomotive practice as well as an extensive chapter on electric propulsion. Record No. 74 covers the general and detailed construction of the gasolene industrial locomotives patented by A. H. Ehle, and manufactured by the Baldwin Locomotive Works. Record No. 75 is devoted to a consideration of the mikado type locomotive and opens with a discussion of the possibilities of that type for different classes of service. Following this, 17 typical locomotives of this type, which have been furnished to as many different roads, are illustrated and described.

## Railway Construction.

**APPALACHIAN ELECTRIC POWER & TRANSIT COMPANY.**—This company has been incorporated in North Carolina, it is said, to build from Wilkesboro, N. C., south to Taylorsville, about 20 miles. T. B. Finley, president, Wilkesboro.

**CHEYENNE SHORT LINE.**—An officer writes that a contract has been given to Levy & Levy, Muskogee, Okla., to build from Strong City, Okla., on the Clinton & Oklahoma Western, south to Cheyenne, seven miles, and that the company expects to have the work finished soon. The plans call for building a total of 70 miles. R. G. Alexander, president and chief engineer, Norman, Okla.

**CUMBERLAND VALLEY INTERURBAN.**—This company has applied for a charter in Tennessee to build from Nashville southeast via DeKalb county to Sparta, about 80 miles. J. H. Cartwright, W. G. Beard, J. W. Jenkins and H. Hancock are interested.

**DALLAS NORTHWESTERN TRACTION.**—See Dallas Southwestern Traction.

**DALLAS SOUTHWESTERN TRACTION.**—Organized in Texas with \$500,000 capital and office at Dallas, to build from Dallas southwest via Cleburne to Glen Rose, 80 miles, with a branch line from Eagle Ford north to Irvin, 10 miles. The same interests are organizing the Dallas Northwestern Traction to build from Dallas northwest via Denton to Krum, 46 miles. The surveys for both these lines have been made, and it is announced that financial arrangements for their construction are completed. The incorporators include E. P. Turner, B. B. Cain, J. T. Witt, J. J. Carter, C. A. Dunn, G. G. Taylor and L. F. Sheppard, Dallas; W. B. McKnight, Mansfield; W. Poindexter and D. Strickland, Cleburne; J. C. Smythe and J. P. Fielder, Venus; B. M. Sansom and W. C. Glasgow, Alvarado.

**GUADALUPE VALLEY TRACTION.**—This company has finished surveys, it is said, for the line from Austin, Tex., south to Lockhart, thence southwest via Sequin to San Antonio, about 100 miles, and grading work is now under way out of Austin. W. D. Dunlop, Beaumont, and J. M. Abbott, Jr., Sequin, are directors. (June 13, p. 1324.)

**GULF, FREEPORT & NORTHERN.**—Announcement is made that the preliminary survey for this new line has been completed between West Columbia, Tex., and Beasley, and the survey between West Columbia and Freeport is to be started in a few days. The plans call for building from Freeport northwest to Sealy, about 80 miles. The company expects to start grading work on August 15. The route to Sealy, the proposed northern terminus from West Columbia, has not yet been fully determined. C. E. Clark, treasurer, Freeport. (July 4, p. 36.)

**HASTINGS & NORTHWESTERN.**—See Union Pacific.

**KINGSTON & EXCELSIOR SPRINGS (Electric).**—Preliminary surveys are being made, it is said, for a line to be built from Kingston, Mo., south via Lawson to Excelsior Springs, about 25 miles. B. Boner, president, Kingston.

**MEXICAN ROADS.**—Announcement has been made that the Compagnie des Chemins de Fer Secondaires de Brussels, Belgium, recently entered into a contract with the Mexican government for the construction of 3,105 miles of railroad, and the company expects to have the surveys for the lines well enough advanced to start grading work by September 1 at several widely separated points. The new lines are to become a part of the National Railways of Mexico on completion. One of the most important of the new lines is to parallel the United States border, traversing the states of Coahuila, Chihuahua and part of Sonora. Another line is to be built from Balsas southeast through the state of Guerrero to the port of Acapulco on the Pacific coast, and a third line from Llano Grande to Mazatlan, crossing the Sierra Madre range.

**MINNESOTA & INTERNATIONAL.**—An officer writes that a contract has been given to A. Guthrie & Co., St. Paul, Minn., to build the cut-off between Leaks, Minn., and Brainerd, 5.8 miles, to provide an improved entrance into Brainerd. (May 23, p. 1116.)

**NATIONAL RAILWAYS OF MEXICO.**—An officer writes under date

of July 5, regarding work on the Vera Cruz-Tampico-Matamoros line with branch to Honey, for which a concession was granted to the company by the Mexican government in March, 1912, that the Vera Cruz-Tampico section is to be over 300 miles long, and will have 0.5 per cent. grades compensated, with maximum curvature of 3 deg., except on a section of about 20 miles over the mesa of Sanatepec, at a point about 140 miles south of Tampico, which will have an elevation of 1,300 ft. above sea level, the maximum grade will be 2 per cent. compensated, with maximum curvature of 6 deg. On top of this mesa the branch line to Honey and to Mexico City leaves the main line. Final location of this section has been completed, and the first 63 miles south of Tampico, including a 1,600-ft. bridge over the Panuco river, is under contract and the work is progressing rapidly. This section includes the petroleum districts of Mexico, also a timber and agricultural country only partially developed. The Tampico-Matamoros section will be about 255 miles long and will have maximum grades of 0.3 per cent. compensated with maximum curvature of 2 deg. Preliminary survey has been completed, the final location is now under way and is about 40 per cent. completed. The Honey branch will connect the Vera Cruz-Tampico-Matamoros line with the central mesa. The company already has a line from Honey to Mexico City. The new line will provide a short route to the port of Tampico, and will be about 75 miles long from Honey to a junction with the Tampico-Vera Cruz line. It will have maximum grades of 2 per cent. compensated and maximum curvature of 8 deg., and will run from an elevation of 1,300 ft. to an elevation of 7,200 ft. above sea level. The preliminary survey has been completed and final location is under way and about 20 per cent. completed. Of these lines about 275 miles will be laid with 85-lb. rail, and about 360 miles with 75-lb. rail. Native hardwood and American pine creosoted cross ties will be used. The work involves handling about 52 million cu. yds. of grading material; erecting about 25,000 tons of steel bridges; constructing about 416,000 cu. yds. of concrete masonry, and boring 22,960 lineal ft. of tunnel.

**NEW YORK SUBWAYS.**—The New York Public Service Commission, First district, has awarded the contract for the construction of the section from the end of the present construction, midway between Houston and Bleecker streets, to Fourteenth street and Union Square, of the Broadway subway in the borough of Manhattan, to the Dock Contractor Company, of Hoboken, N. J., and New York. This company's bid of \$2,578,078 was the lowest bid submitted for the work. (July 11, p. 77.)

**OHIO ROADS (Electric).**—According to press reports, plans are being made to build a line to connect Cincinnati, Ohio, Reading, Carlisle, Germantown and Dayton. J. G. Miller, Middletown; F. J. Ferneding and O. L. Mead, Dayton, are said to be interested.

**ORLEANS-KENNER (Electric).**—Plans are being made, it is said, to start work on a line from New Orleans, La., west via Kenner to Hanson City, about 12 miles. A. S. Bowman, president, Wilcox, La.

**PAWHUSKA & NORTHEASTERN.**—An officer writes that contracts are to be let early in August to build a section of this line. The plans call for building from Pawhuska, Okla., northeast to Caney, Kan., also to build from Pawhuska southwest to Skedee, or west to Ponca City, in all about 85 miles. Grading has been finished on three miles. There will be three steel bridges varying in length from 60 ft. to 110 ft. each, and four trestles, also five station buildings. The company expects to develop a traffic in livestock, oil and gas well supplies, lumber and general merchandise. J. B. Tolson, president, and C. C. Godman, chief engineer, Pawhuska. (July 18, p. 132.)

**PORTLAND & OREGON CITY (Electric).**—Incorporated in Oregon with \$200,000 capital, to build a 14-mile line from Portland, Ore., south to Oregon City. P. T. Fletcher, D. E. Fletcher and F. Venzermeer are interested.

**SAN ANTONIO & AUSTIN INTERURBAN.**—Surveys have been made for the line from San Antonio, Tex., northeast via New Braunfels, Hunter, San Marcos, Kyle, Buda and Manchaca to Austin, 77 miles. The company is securing the right of way and necessary franchises. Address W. B. Tuttle, San Antonio. (March 28, p. 779.)

**SOUTHWESTERN TRACTION & POWER COMPANY.**—An officer writes that work has been under way for some time on the line from Morgan City, La., northwest via Franklin, Baldwin, Jeanerette, New Iberia, St. Martinsville and Lafayette to Abbeville, in all about 80 miles. Track has been laid on 13 miles. The work is being carried out by the company's forces. A contract for a power plant has been let to W. H. Schott & Co., Chicago. Jules Godchaux, president, New Orleans, and W. S. Henning, New Iberia, is engineer in charge of construction.

**SOUTHWESTERN TRACTION.**—An officer of this company, which operates a line from Belton, Tex., northeast to Temple, writes that surveys are nearing completion for a line between Waco and Austin. The Belton-Temple line is to form part of the through line. A. M. Coffin, chief engineer, Temple.

**TOBIQUE & CAMPBELLTON.**—The Canadian government has voted a subsidy at the usual rate in place of the subsidy voted in 1910, for building a line from Plaster Rock, N. B., north along the Tobique river valley to Riley Brook, 28 miles. It is understood that the company is ready to begin the construction work. This line is to form an extension from Plaster Rock, of the Tobique Valley railway, which is operated by the Canadian Pacific.

**TIMPSON & HENDERSON.**—This road, now in operation from Timpson, Tex., northwest to Henderson, 34 miles, will probably be extended from Henderson west via Tyler to Kaufman, about 100 miles. Plans have been under way for some time to build the section from Henderson west to Tyler, about 35 miles.

**UNION PACIFIC.**—Announcement is made that work has been finished on the Hastings & Northwestern, from Hastings, Neb., northwest to Gibbon, 26 miles. The completion of this line provides a short route from Topeka, Kan., via Marysville and Hastings, Neb., to the main line in Nebraska at Gibbon. (September 13, p. 491.)

#### RAILWAY STRUCTURES.

**GREENWOOD, S. C.**—An officer of the Seaboard Air Line writes that a contract has been given to C. V. York, Raleigh, N. C., to build a one-story brick freight house, 41 ft. x 211 ft. at Greenwood. The cost of the new structure will be about \$16,000.

**LOVERING, ONT.**—The Railway Commissioners of Canada have authorized the Canadian Pacific to build a bridge over North river, Muskoka subdivision, Ontario division; also to build a bridge on Hamilton subdivision, Ontario division.

**TACOMA, WASH.**—The Oregon-Washington Railroad & Navigation Company has announced that a new freight warehouse, team tracks, yards and bridge will be built at this point in the near future, although detailed plans have not yet been arranged.

**YORK, ALA.**—An officer of the Alabama, Tennessee & Northern writes that a steel and galvanized iron general repair shop 110 ft. x 165 ft. with concrete foundations, is being built at York. The Decatur Bridge Company has been given a contract for the superstructure, and the foundation work is being carried out by the railway company's forces.

**CANTON-HANKOW RAILWAY, CHINA.**—Work upon the southern section of the Canton-Hankow railway (Kwangtung-Yueh-Han railway) under the present management and ownership seems to be progressing much more favorably than has been expected in view of the upset condition of Chinese railway finances. A special train was run from Canton to Ying Tak, 190 miles, on May 10, 1913, officially opening the line to that station. Ying Tak is 3 miles from the main line. The station on the main line where connection is made with Ying Tak is 87 miles from Canton, making Ying Tak 190 miles. It was intended to have Ying Tak on the main line, but the local authorities would not allow the railway company to build a track sufficiently high to avoid being under water each year some 10 to 20 days. Accordingly the latter have constructed a line so that they will run by Ying Tak during high-water periods. For the protection of employees at Ying Tak station, they are constructing a two-story building of sufficient height so that the employees can live on the second floor and be protected from the floods.

## Railway Financial News

**ATCHISON, TOPEKA & SANTA FE.**—It is understood that this company has acquired control of the St. Louis, Rocky Mountain & Pacific. The St. Louis, Rocky Mountain & Pacific runs from Des Moines, N. Mex., on the Colorado & Southern, to Ute Park, 94 miles, with branches into the Dawson coal fields.

**BALTIMORE & OHIO.**—White Weld & Company, New York, have bought from the railroad company and are offering to the public a new issue of \$1,370,000 of the Baltimore & Ohio first mortgage 4 per cent. bonds of 1898-1948. The offering price to the public is 89, yielding 4½ per cent. on the investment. These bonds are a part of the authorized issue of \$165,000,000 of which \$79,978,750 are outstanding. These first mortgage bonds are a legal investment for savings banks in Massachusetts. They are a first lien either by direct mortgage or collateral trust of 575 miles of road, including 108 miles of the double track main line between Baltimore and Philadelphia and 346 miles of main line from Akron, Ohio, to Chicago.

**KANSAS & SOUTHWESTERN.**—See a note in regard to rates and assessments in General News.

**NEW YORK, NEW HAVEN & HARTFORD.**—Upon the announcement of the resignation of Mr. Mellen, commented on elsewhere, a committee consisting of Theodore N. Vail, chairman; J. P. Morgan, Samuel Rea, William Skinner, Edward Milligan and Robert W. Taft was appointed by the board of directors to consider and recommend a successor to Mr. Mellen.

The directors have authorized and have called a special meeting of the stockholders to approve an issue of \$67,552,400 6 per cent. 20-year convertible debenture bonds, to be convertible at par into stock at the option of the holder between 1918 and 1928, and stockholders are to be asked to approve the necessary increase in capital stock to provide for such conversion. The plan is to offer the convertible debenture 6's to stockholders of the New Haven at par. The proceeds from the sale of these debentures will be used to provide for \$40,000,000 notes maturing December 1, and \$5,000,000 maturing February 1; the remainder to pay for electrification, new equipment, elimination of grade crossings, etc. At present the New York, New Haven & Hartford has outstanding \$180,013,000 stock, on which 6 per cent. dividends are being paid, and about \$132,000,000 debentures.

**PENNSYLVANIA.**—The Public Utilities Commission of New Jersey has refused to approve the lease by the Pennsylvania Railroad of the West Jersey & Seashore for 999 years. The grounds on which the refusal is based is that the West Jersey & Seashore will not give the commission any assurance that the 6 per cent. guaranteed dividend will not be used as a plea in any rate cases which may later develop.

**ST. LOUIS, ROCKY MOUNTAIN & PACIFIC.**—See Atchison, Topeka & Santa Fe.

**SOUTHERN RAILWAY.**—This company has sold \$1,750,000 5 per cent. equipment trust notes, maturing semi-annually from February, 1914, to 1923. The notes were offered to the public at prices yielding from 5¾ per cent. to 6 per cent.

**WABASH.**—The Equitable Trust Company of New York has filed a petition with the Federal Court asking for permission to intervene in the foreclosure suit brought by the Central Trust Company as trustee for the \$5,000,000 4½ per cent. notes. The Equitable Trust Company is trustee for the first and refunding mortgage bonds of the Wabash.

**WEST JERSEY & SEASHORE.**—See Pennsylvania.

**AERIAL RAILWAY IN COLOMBIA.**—By permission of the Colombian government, Thomas Miller, who held a concession from the government for constructing an aerial railway between Manizales, Pereira, or Neira, and the National Occidental Railway, has transferred his concession to the Dorada Railway, Ltd., of London. Six months' extension of time for putting the railway into service has also been granted.

# Railway Age Gazette

PUBLISHED EVERY FRIDAY AND DAILY EIGHT TIMES IN JUNE, BY THE  
SIMMONS-BOARDMAN PUBLISHING COMPANY,  
WOOLWORTH BUILDING, NEW YORK.

CHICAGO: Transportation Bldg. CLEVELAND: Citizens' Bldg.  
LONDON: Queen Anne's Chambers, Westminster.

E. A. SIMMONS, *President.*  
L. B. SHERMAN, *Vice-President.* HENRY LEE, *Sec'y & Treas.*  
The address of the company is the address of the officers.

EDITORS.

SAMUEL O. DUNN, *Editor.*  
ROY V. WRIGHT, *Managing Editor.* E. S. FAUST  
W. E. HOOPER H. H. SIMMONS F. W. KRARGER  
B. B. ADAMS E. A. AVERILL A. D. CLOUD  
E. T. HOWSON R. E. THAYER GEORGE L. FOWLER  
A. G. LOUDON

Subscriptions, including 52 regular weekly issues and special daily editions published from time to time in New York, or in places other than New York, payable in advance and postage free:

United States and Mexico.....	\$5.00
Canada .....	6.00
Foreign Countries (excepting daily editions).....	8.00
Single Copies .....	15 cents each

Engineering and Maintenance of Way Edition and four Maintenance of Way Convention Daily issues, North America, \$1.00; foreign, \$2.00.

Entered at the Post Office at New York, N. Y., as mail matter of the second class.

WE GUARANTEE, that of this issue 8,150 copies were printed; that of those 8,150 copies, 6,606 were mailed to regular paid subscribers and 850 were provided for counter and news companies' sales; that the total copies printed this year to date were 267,808—an average of 8,628 copies a week.

VOLUME 55. AUGUST 1, 1913. NUMBER 5.

## CONTENTS

EDITORIAL:

Editorial Notes .....	171
American Society for Testing Materials.....	172
Working the Space Interval System with Inadequate Signals.....	173
New Books .....	173

LETTERS TO THE EDITOR:

Boiler Tube Specifications; by G. R. Henderson.....	174
Pulverized Fuel for Locomotives; by Walter D. Wood.....	174
Circulation in Firebox Water Legs; by Walter D. Wood.....	174

MISCELLANEOUS:

Getting More Movement for Freight Cars; by Arthur Hale.....	175
*Howard Elliott .....	177
American Railway Tool Foremen's Association.....	178
*James H. Hustis .....	179
Statistics of Railways for the Year Ended June 30, 1912.....	180
Train Accidents in June .....	182
*Long Island Improvements at Jamaica.....	183
*New Engine Terminals on the Western Maryland; by Gustave E. Lemmerich .....	189
*Development of the East Indian Railway; by Lewis R. Freeman..	191
*Automatic Train Pipe Connector .....	195
*Welding and Cutting with Oxygen and Illuminating Gas.....	196
Foreign Railway Notes .....	174, 175, 178, 181, 182, 190

GENERAL NEWS SECTION..... 197

\*Illustrated.

practice of railroads and of other large public service corporations of turning to the daily newspapers to put before the public in this manner their side of controversies is one of the distinctly wholesome signs of the times. In the first place it shows that the roads must have a sound case if they are to win it by thus appealing to the public as judges. No matter how misleading or clever advertising may be it must in the long run depend for its success on the quality of the goods advertised, and the same is true of the arguments in a controversy. Furthermore it is a recognition of a fair public opinion which is willing to hear both sides. This is a long step away from the attitude taken by some of the older schools of railroad men who contemptuously dismissed any efforts to appeal to the better class of public sentiment through a policy of frankness by expressing the opinion that the general public were both too ignorant and too lazy to try to form a just opinion; and that it was cheaper to bribe legislators than it was to pay for advertising. If a railroad manager sits down and tries to write out a half-page advertisement setting forth his side of a controversy he is pretty likely to learn a great many things about the other side of the question that never would have come to his notice in the ordinary course of events. Furthermore, as he strengthens his case on paper, he unconsciously looks for and corrects mistakes in management that have helped to lead to the very state of public opinion which he is trying to change. In this connection the address of President Finley reprinted elsewhere in this issue is of especial interest.

IN the *Railway Age Gazette* of June 20 we commented at some length on bulletins commending employees, and in the issue of July 11 in an article entitled "Merits and Demerits," published a list consisting entirely of records of discipline administered. For about two years the Pennsylvania Railroad has been issuing monthly bulletins showing commendations as well as cases of discipline relating to employees. In another column there are reprinted the commendations for a single month for one division—not grand division—and also certain selected cases from the discipline administered. An employee who has performed a commendatory act receives a letter of commendation signed by the superintendent, so that he has something of record to show in the future should he come up for discipline. Such commendation is considered as an offset in administering discipline and mitigates, or may even eliminate, the serving of the discipline, although the employee's record is shown charged with the full discipline to which he was liable. There are some points of especial interest about the list which we publish. In the comments in these columns on "Commending Employees" it was pointed out that there ought to be some distinction between an employee who does good work in the line of his duty and one who goes outside of his duty to further the interests of his company. In the bulletin which we reprint commendation in most cases is given only where an employee has gone outside of his duty to further the interests of the company; and in cases, as, for instance, where an engineman and fireman were commended for keeping an engine in a clean condition, we may assume from the common sense spirit that is maintained in both the commendation and discipline that commendation in this case was given because of the *unusually* good performance of duty. The cases of discipline selected were taken because they show a certain courage that is rarer than it should be in the administration of discipline on matters that are of real importance. It is so easy for a superintendent or trainman to shut his eyes to a freight flagman throwing refuse on the ground, instead of putting it in a garbage can, or to a brakeman allowing a passenger to board a train in error, simply by persuading himself that all he can be responsible for are the results in the matter of handling business that are obtained by the employees on his division.

**I**N 1864, the main line of the East Indian Railway was open from Calcutta to Delhi, 1,020 miles, with the single exception of a break at the ferry where the Jumma bridge at Allahabad was still unfinished. The chairman of the board of directors said at the time that not even the Grand Trunk of Canada could compare with it in length of line. Although this statement was incorrect the Grand Trunk was the only railway which did have a greater mileage, for there was not a single company in the United States which could equal it. On June 30, 1864, the Grand Trunk was operating 1,335 miles of line, and the railways with the greatest mileage in the United States were the New York Central & Hudson River, with 804 miles, and the Pennsylvania Railroad with 797 miles. On June 30, 1865, the Chicago & North Western had 847 miles of line in operation. At first thought one would scarcely expect to find a railway with such a large mileage in India at that time, but it is not so surprising, for nowhere else were the conditions so favorable or the incentives so strong. The East Indian Railway was backed by the Honorable East India Company, one of the richest and most powerful organizations in existence. The territory penetrated was exceedingly fertile and the density of the population was greater than in any other region then being opened up by railways. The country was flat and offered few difficulties to construction, and labor was plentiful and cheap. England was trying to civilize a very backward nation, and the great value of railways as a civilizing force was appreciated even then. Moreover, England had suffered severely from the lack of railways during the Sepoy rebellion, seven years before, and was determined to profit by that lesson. The conditions in the United States were very different. The population was dense only in widely separated localities. It was growing rapidly, but in such a way that the railways found it profitable only to serve restricted districts. The total mileage in operation in the United States in 1864 was 33,908, doubtless greater than in any other country, but this was divided up among a very large number of companies. Until that time no company had risked connecting very distant communities on account of the comparative dearth of traffic that would have existed throughout a large part of the territory traversed. Also, the country had been in the throes of the Civil War, which had greatly reduced the supply of money and labor, and had consequently materially retarded railway development. Canada, on the other hand, had not been handicapped in this manner and could afford to build long stretches of line, invading American territory to secure the traffic, which, in a large measure, would have gone to American railways had the conditions been otherwise. At that time, therefore, although the United States had the greatest railway mileage in the world, either of two foreign companies could boast of greater mileage than any single company in this country.

**A** WIDESPREAD controversy, in which many varying opinions have been expressed, has been aroused by a ruling issued by the Interstate Commerce Commission in May that carriers may be permitted to charge for copies of their tariffs, not to exceed the cost of the paper, extra printing and mailing. The commission announced the opinion that it is discriminatory to furnish tariffs free to some shippers or associations unless the privilege is accorded to all, and held that if tariffs were to be charged for the carriers must publish price lists and furnish enough copies to meet the demand. On June 16 Agent Leland of the Southwestern Lines issued a price list of tariffs, to become effective July 1, but the date has since been postponed at the request of shippers to October 1. The entire matter involves some perplexing questions. Shippers naturally take the position that tariffs are the railways' price lists, analogous to the catalogs issued by business houses, and that they should be furnished free to all who ask for them. Under the law shippers are required to be informed as to the correct rates and have the right to request quotations in writing. The railways are also required to publish tariffs and post them publicly at stations,

subject to the commission's orders. This creates a situation slightly different from that of other kinds of business, that are not subject to regulation and are free to publish or not publish price lists and to issue or deny them to whom they please. Moreover, there are cases in which business houses that publish very elaborate and costly catalogs do impose a nominal charge for them to avoid the waste of allowing them to fall into the hands of people who would make no use of them. One of the principal arguments advanced by those in favor of charging for tariffs is the large waste now involved in issuing expensive tariffs to those who have little or no use for them, and while carriers may undoubtedly reduce this by more frequent revising of their mailing lists it is difficult to see how a large waste can be avoided if they are required to furnish tariffs indiscriminately to all who ask. On behalf of the shippers it has been urged that if the shippers of the country should to any extent decline to pay for tariffs and call upon the carriers to quote rates the extra expense in clerical hire to meet the demand would easily exceed the cost of tariffs, and that shippers are now making use of their tariffs to perform a great deal of service for the railways. The shippers, however, are not looking up their own rates for the benefit of the railways, but because it is to their own interest to do so. The publication and posting of tariffs under the requirements of the law have added a very considerable sum to the expenses of the railways which must be paid by the public in some form or another. It would seem to be only equitable to distribute a part of this cost among those for whose requirements it is incurred.

#### AMERICAN SOCIETY FOR TESTING MATERIALS.

**A**T the annual meeting of the American Society for Testing Materials, which was held at Atlantic City recently, there were presented the usual large number of papers and reports some of which were of high scientific and commercial value, while a justification for their presentation would be difficult to find for others. The society labors under the same disadvantage that handicaps all technical associations of a broad and general character. Its interests are so wide and so diversified, covering as they do the whole general subject of scientific investigation, that it is impossible to obtain a discussion that is really worthy of the name on any one subject. Hence papers are presented that receive such scant attention as to be discouraging to their authors. Then, too, the very fact that the standing of the society is high and the work that it has done is valuable, attracts papers that ought not to be accepted from men who have little or no notion of what a scientific investigation really means. They have made a few tests, limited in scope, possibly for a specific purpose, and then they proceed to prepare an elaborate paper giving minute details that are of no value and from which no conclusion or recommendation can be or is drawn. In fact one of the crying weaknesses of the society is that so many papers are written that lead nowhere and tell nothing and serve no recognizable purpose other than that of placing the names of the authors for a few brief moments before the association, to be at once forgotten, unless the effort happens to be particularly bad, as happens occasionally, when it would have been better had the effort not been made.

These are weaknesses that can probably be remedied, though it is difficult to say just how. A reading committee that could pass intelligently on all papers offered would have to be a complete compendium of human knowledge, and such a committee would, of course, be impossible to procure. Still it does seem that a censorship somewhat more rigid than that apparently exercised would be well.

The specifications adopted by the association are of a high and ranking character, though they sometimes fail to fully grasp the requirements and ideas of consumers in every particular. But they are usually drawn by specialists who work long and earnestly and represent the best practice. It is for this reason,

as well as because of the generally diversified character of the membership, that there was much force in the secretary's plea that no changes should be made in the open meeting, in proposed specifications. His claim was that the membership was not qualified to make changes, and that the most that should be done would be to refer back to the committee for reconsideration. This holds, too, for the final adoption of specifications by letter ballot. It is safe to say that the great majority of the members are incapable of voting intelligently on any one set of specifications. For example, what does the steel manufacturer know about the qualities of linseed oil, or what moral right has the chemist of a paint manufacturer to cast a vote on steel rails, and yet this is exactly what a letter ballot of the society invites. Hence, it is well to regard its specifications as the output of committees of specialists, and, as such, entitled to the corresponding amount of respect and confidence, sanctioned by the society at large because its members have seen fit to pass what amounts to a vote of confidence in the formulating committees.

**WORKING THE SPACE INTERVAL SYSTEM WITH INADEQUATE SIGNALS.**

A CORRESPONDENT wants to know what is the safest and best practice in manual block signaling in a situation like that illustrated in the sketch shown below. The scene is on a prominent eastern road. Extra train No. 72, going south, at W is obliged to wait there for regular train No. 10, going north, which is at A. The dispatcher issued an order for the trains to meet at W and then, to save time, issued a second order to Extra 72 authorizing it to pass the signal at W under full

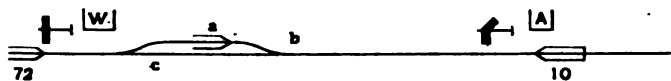

flag protection, so that it could be clear of the main track in season to cause a minimum delay to No. 10. "On approaching W No. 10 was flagged, the other train, with its engine at a, not having got in to clear.

The principal point at issue, concerning which our correspondent appears to have had some controversy with his superior officer, is whether it was proper to give to No. 10 (as was done) a clear signal at A. The operator at A received from W a "clear block"; that is to say, authority for No. 10 to run to the signal at W. This signal was beyond the switch at which the Extra had to enter the side track; but the meeting order had the effect of ordering No. 10 to stop before it had reached this switch.

We print this statement and question, not because we propose to sit as a judge in the controversy, but rather as an illustration of the difficulty of managing the block system without a suitable equipment of fixed signals. The patchwork by which two or three different rules, in different parts of the code, are depended on for the safety of two simple train movements, is no worse patchwork than will be found in many other situations, and is not so bad as will be seen every day in many places; but it remains patchwork, and is tolerable only because much time and money would be required to change bad practice to good.

The dispatcher in this case provided a double protection; and therein felt, no doubt, that he had taken all necessary precaution. Proper obedience to the meeting order required No. 10 to stop at c; that was one protection; and the flag, stopping the train at b, was another. To give a stop indication by semaphore at A, the same being modified by the meeting order, would have been another. With the use of this last provision the flagging might have been omitted. Whether this would have been better may depend on a number of circumstances. If the time consumed between A and W was considerable, the chance of forgetting the signal indication would be an element. The practice of setting signals at stop and then issuing written orders which

contradict the signal indication is to be deprecated, for it tends to weaken the signal system. Every thoughtful railroad officer desires to make of signaling an exact science; this practice thwarts that purpose. But dependence on the flagman also has its difficulties, and we shall not quarrel with the man who tries to make a train movement safe without the flagman. Dependence solely on the rule which would have required No. 10 to stop at c, involves complete confidence in the examiner who has educated the engineman in obedience to rules; so here is another difficulty. No examiner that we know of has been able to bring every one of his enginemen up to 100 per cent., even on paper.

Having all these factors to consider, with their admitted perplexities, why not adopt the brief rule that all trains shall approach all stations under control? This would be simple. Admittedly, it would have to be very rigid. But it could be safely modified, in the case of important express trains, by giving written orders conferring unlimited right from Station A to Station C (ignoring the signals at Station B); and with adequate care it might be all right to give such an order by signal instead of on paper. This under-control rule would arouse instant rebellion, all around, without doubt. But so did the block system, at first. But if adopted it would have great educational value and it would enforce the lesson that there ought to be adequate home, starting and distant signals at every station. With these facilities at W and A the dispatchers, trainmen and others who disagreed in this case would have been freed from their perplexities, and they would have been able to sleep soundly at night.

In Ireland, Australia, Japan and certain other countries which in some respects are more enlightened than America, the progressive railroad manager is not satisfied, at single-track meeting points, with anything less than a symmetrical loop; that is to say, meeting tracks so laid that trains from both directions

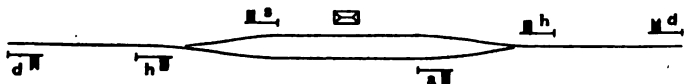

can run fully up to the station before encroaching on the rights of trains from the opposite direction. This simple arrangement is shown in the sketch above.

**NEW BOOKS.**

*The Steam Consumption of Locomotive Engines from the Indicator Diagrams.* By J. Paul Clayton. Bulletin No. 65 of the University of Illinois Engineering Experiment Station. Copies may be obtained upon application to W. F. M. Goss, Director of the Engineering Experiment Station, University of Illinois, Urbana, Illinois.

This bulletin applies to locomotive engines the logarithmic analysis developed in bulletin No. 58 of the engineering experiment station by the same author. In bulletin No. 58 it was shown that the expansion curves of all steam engine indicator diagrams obey substantially the polytropic law  $P V^n = C$ , and that the value of n is controlled directly by the quality of the steam mixture in the cylinder at cut-off. It was further shown that each distinct type of engine possesses a series of definite relations between the values of n and steam quality at cut-off, and that, by determining their relations, the actual steam consumption of engines can be closely determined from the indicator diagrams alone. This present bulletin gives the relations of n and steam quality at cut-off as determined from the tests of twelve locomotives, and shows that the steam consumption of these locomotives may be determined by this means to within 4 per cent. of the steam consumption as measured on test plants. Methods are developed for measuring valve leakage, the proportion of steam used for heating the train in winter, the spring in valve gears, cylinder clearance, cylinder leakage, and the cyclic events.

## Letters to the Editor.

### BOILER TUBE SPECIFICATIONS.

PHILADELPHIA, Pa., June 21, 1913.

TO THE EDITOR OF THE RAILWAY AGE GAZETTE:

I beg to call your attention to an item on page 1369 of the *Daily Railway Age Gazette* of June 14, in which criticism is made of the American Society for Testing Materials committee for not keeping in touch with the Master Mechanics' Association committee. Whoever wrote this item was certainly not aware of the facts, because as chairman of the A. S. T. M. committee I have been in constant correspondence with Mr. Henry, the chairman of the Master Mechanics' Association committee and, in fact, the A. S. T. M. committee had a representative present at one or two of the Master Mechanics' Association committee meetings. The proposed specifications have been frequently interchanged and harmonized the one with the other, and they now almost agree exactly, with the exception of one or two minor modifications which were introduced in the Master Mechanics' committee after the A. S. T. M. committee suggestions had been approved by the meeting of that society; it is the intention as soon as these specifications are approved by a vote of the Master Mechanics' Association to harmonize the two absolutely. They would have agreed had not the Master Mechanics' committee made some alterations after the A. S. T. M. specifications and the Master Mechanics had been brought together, it was thought, finally.

G. R. HENDERSON.

### PULVERIZED FUEL FOR LOCOMOTIVES.

ALTOONA, Pa., July 21, 1913.

TO THE EDITOR OF THE RAILWAY AGE GAZETTE:

Since the publication of my article on "Powdered Fuel for Locomotives," *Railway Age Gazette*, July 4, I have been quite severely criticized by one or two engineers who say my article is "too previous—that what I claim, I have done on paper only and that I have no facts or proof to back up my assertions." Every engineering feat of any importance was done on paper first; hundreds of successful inventions and devices have been made successful by studying and profiting by the mistakes of others.

True, a Scotch marine boiler on a locomotive is revolutionary—so were steam turbines on our biggest ocean liners. Oil is being successfully used on locomotives—why not powdered coal? Oil is practically a gas, as it ignites—so is coal. Although powdered coal is in form a gas, it is far different from oil at the point of ignition. The most perfect nozzle or spray for oil yet devised cannot begin to approach in its fineness of mixture the fineness of powdered coal; it cannot begin to approach the perfect intermixture of air and coal which is possible with powdered coal. It has been shown that a big percentage of it is so fine and light as to remain in suspension in the air when allowed to escape. Will oil do this? Gasolene is admitted to be much more volatile than kerosene, and much more still than fuel oil, as used in furnaces, yet even the most expensive carbureters built, after years of experience, have been shown to be inefficient in mixing the gasolene and air, by simply inserting an additional air mixing device in the manifold to still further break up these small particles of gasolene.

In all the attempts to fire powdered coal on locomotives in the past practically every one was conducted and tried along lines similar to those used with oil, and just as long as this system is carried out failure will be the reward. Powdered coal is as different from crude fuel oil as the highest test naphtha. Why engineers and other experimenters have not realized and benefited by this I cannot comprehend, and until they do they may as well try to develop perpetual motion.

Powdered coal can be burned economically in a locomotive, perhaps not as efficiently as on one especially designed for its use, but well enough to prove its worth as a successful fuel. Give me the biggest Mallet, a pulverizer, fan and all the material necessary for the work, and in forty-eight working hours I can equip it ready to run on the road with powdered coal as fuel. This can be done without altering the boiler in any respect whatever, the only changes being minor ones in the firebox and tender. Though it costs roughly about thirty cents a ton to dry and pulverize the coal, I will guarantee to show at the end of a day or week's run a saving on the credit side of the ledger. Of course, as I said, this would not be as efficient as a boiler specially designed for it, yet it would prove cheaper than the most efficient superheater.

One reason that this is so is because every pound of coal burned is doing work; you are not wasting several tons a day keeping up steam in roundhouses, standing on sidings, waiting for orders, etc. There is no wood needed to start fires, no ashes to clean out, no fires to knock out. Why? Because a powdered coal flame—once the firebox is heated—can be turned off and relighted as readily as gas. If a train has to stand five minutes in a station the flame is cut off entirely. It isn't necessary to baby and rake and shake a fire prior to taking a long grade, it is as easy to increase the heat as it is to open the throttle. Think what this means alone. The abolishing of steam failures. At a test several years ago when they still had steam engines on the Manhattan Elevated an engine equipped to burn powdered coal ran all the way to Harlem and back with the boiler heated simply by the fire brick—the flame being shut off entirely. Their boiler was a success but their method of firing was not.

Tradition and past performances are hard things to fight, and many an inventor has gone down to discouragement simply because he had something which others had tried and said couldn't be done.

WALTER D. WOOD.

### CIRCULATION IN FIREBOX WATER LEGS.

ALTOONA, Pa., July 21, 1913.

TO THE EDITOR OF THE RAILWAY AGE GAZETTE:

In the *Railway Age Gazette* of July 18, page 91, you had an article, supplemented by drawings purporting to show the direction of circulation of the water in the legs of a firebox, the device used for the experiment being a glass tube bent in different forms to represent a section. This would do all very well for a class room experiment, but it does not at all comply with conditions as they are in the firebox.

If the space between the inner and outer walls of the firebox were subdivided by solid plates, such as *AB-CD*, etc., as I have shown in Fig. 2, permitting of no circulation between *X* and *Y*, *Y* and *Z*, etc., then the conditions would be the same as in the tube experiment. As it is, it is not unreasonable to suppose that the comparatively colder water along the bottom of the barrel of the boiler will take the course shown by the arrows in Fig. 1, flowing in to fill the place vacated by the water rising along the sides of the water legs. A few sensitive pyrometers might help to prove this. If the author of the article had had a series of tubes connected at top and bottom he would have been nearer to the solution, but still far from it.

WALTER D. WOOD.

PROJECTED LINE IN KWANGTUNG, CHINA.—For some time there have been discussions as to the necessity of joining the populous town of Tsang Shing on the East river with the main line between Canton and Kowloon. It will attach itself to the main line at Shek Lung. It will not be a long line, only about 14 miles. On the other hand, it will pass through two or three large towns. The promoters affirm that the way is level and that land can be purchased cheaply. The same company has also suggested other lines, joining the towns in the district north of the East river.

# GETTING MORE MOVEMENT FOR FREIGHT CARS.

Delays at Terminals Present the Hardest Problem.—Suggestions Regarding Some Means for Overcoming Such Delays.

BY ARTHUR HALE,

General Agent, American Railway Association.

The meager car surpluses remind us that there may be a car shortage earlier than ever this fall. The surplus on June 30 was no greater than it was on the 1st of February, and was just what it was a year ago. Let us consider what should be done to avoid, postpone or minimize the car shortage which may be waiting for us next October.

First, then, let us ask what is a car shortage. Is it necessarily a lack of cars? The answer to this, of course, is "No." We have enough cars if we can move them faster. To avoid a car shortage, then, we need either more cars or more movement, and it will be better if we can have both more cars and more movement.

As to the cars, the answer is easy. Last year the roads built 150,000 new freight cars, and this year they are nearly 10,000 cars ahead of their last year's record. Something is being done in this line.

Now, how about movement?

What do we mean when we say the movement can be improved? Do we mean that our freight trains ought to be run faster? Any railroad man will tell you "No"—that to run freight trains faster is not the best way to secure a better movement. He will explain that the freight car is in motion only a small fraction of the time, and that what is needed is more movement of the kind we have now, and not faster movement.

The latest average movement that the Interstate Commerce Commission has given us, which is for the fiscal year 1910, was 24 miles a day. The maximum movement reported to the American Railway Association by its members was for October and November, 1912, when the movement reached 26 miles per day.

The usual arrangement with train employees is that they are to be paid overtime when the freight train makes less than 10 miles an hour. This 10 miles an hour is generally accepted as a proper movement for a freight car. At this rate our freight cars in the fiscal year 1910 were in motion one-tenth of the time, and in our record months they were in motion about one-ninth of the time. Certainly, there is a chance for more movement of a vehicle which stands still eight hours for every hour it is in motion.

These are the recognized statistics, but it is perhaps a pity that the railways should put their worst foot forward by acknowledging this record of 24, or even 26 miles per car per day.

It is not generally understood that this gives only the road movement of a car and omits all switching mileage, nor is it well understood that a car is necessarily switched a great many times in each of its round trips, and that each of these switch movements necessarily takes a good deal of time. It is, however, too late to change this basic figure. It is about the only thing we have as a basis of comparison on this question, so we will let it go.

Let us consider who is responsible for car delay. This responsibility is divided between the public and the railroad. Delay by shipper and receiver should be adequately taken care of by demurrage rules, and there is a general impression that on the whole there is less delay by the public than there used to be. Unfortunately, there are no statistics by which this can be proven. The only information which covers the whole of the country is a figure given by the Interstate Commerce Commission of \$7,764,964 demurrage collected by the railways in the fiscal year 1911. The commission will give us this fig-

ure for 1912, and for future years, but we have no figure covering the whole country prior to this one for 1911. We have, to be sure, the statistics of certain demurrage bureaus showing delay by shippers or receivers, but these figures are not made on a uniform basis, nor do they cover the whole country. We cannot, therefore, tell how much the shippers and receivers should help us, but we shall know more on this point in the future. Certainly, some of the shippers and receivers made great efforts to secure prompt handling of cars during the car shortage last fall and winter, and we trust they will continue these efforts even more successfully this year.

Now, as to delay by railroads, and in this delay I will include shifting movements. As stated above, the railways do not credit themselves with any mileage on account of these shifting movements, and usually the time occupied in a switch movement is much less than the time in which a car stands awaiting such a movement. Delays by railroads appear to be divided into four kinds—delays en route, delays in yards, delays in shops, and delays in storage, and by this last word "storage" I mean the holding of all available cars for which there is no immediate prospective loading.

Delay en route is something the railways know all about, or can know all about if they want to. It is indicated very clearly and cogently by the overtime which is paid train crews. Further than keeping overtime to a minimum, it is generally agreed that delay en route need not be considered.

Delay in storage is not usually an important matter in the periods of car shortage, because in such periods there are no cars stored, and there ought to be no cars stored. If, in exceptional cases, cars are stored in periods of car shortages steps should certainly be taken to turn the cars over to roads which need them.

Delay in shops is also a matter on which the railways are fully informed. This subject was treated in an article published in the *Railway Age Gazette* of July 11, 1913, which shows the necessity of repairing cars now. It is gratifying to observe that the corner has been turned this year earlier than usual. The per cent. of cars in shops appears to have reached its maximum on May 31, and an improvement is shown as of June 14.

The bulk of delay in periods of shortage is to cars standing in yards awaiting movement. This includes both loaded and empty cars. There are cars delayed in this way waiting to go into shops and coming out of shops; cars awaiting delivery to connections, and awaiting movement from interchange tracks, and lastly, and this is probably the most important item, there is a great total of cars, loaded and empty, awaiting road movement, some in terminals and others in yards where engines are changed.

L. F. Loree, in a recent article in the *Engineering Magazine*, estimates the average delay to cars awaiting such movement as 10 hours and 32 minutes. This was on the basis of the average movement of the year 1910. Last fall, when a record movement of 26 miles a day was made, this "yard delay" appears to have been reduced to 8 hours and 16 minutes, and even this seems too large. Some roads brought this average delay down to 4 or 5 hours, and these are the roads which have made the best record in moving cars and in moving freight.

The problem for the transportation departments of the country, then, during the next car shortage is to reduce the delay to cars in yards.

It is hard to believe that the average freight car on an aver-



age railroad stands still for 10, or even 8 hours, when it is all ready to go somewhere. Probably the average car does not wait as long as this for road movement, and the greater delays are in the local movement.

For instance, on large railroads cars are arriving at large terminals at all hours of the day and night. There is often only one shift a day to certain private sidings. If a car for such a private siding does not reach the terminal in time for this shift it has to lie over 24 hours. To this delay Sundays and holidays are to be added. In such cases the average delay is well over 12 hours and this delay cannot be reduced unless two shifts a day are given. This is typical of all cases where cars may arrive at a point at any hour in the 24 for connection with any local movement which is made only once every 24 hours.

Cars are sometimes held for "solid trains" longer than is intended, and cars may be held for quite considerable periods on account of one error or another on the part of the railroad or the shipper. All these delays are, of course, entirely outside of the regular "free time" allowed the roads' patrons for loading, unloading, inspection, reconsignment, etc.

But even if these extreme cases are cut out, the delay in yards awaiting road movement is often longer than is fully appreciated. Many a railroad manager is perfectly content when he looks over his reports in the morning and finds that while in the previous 24 hours there were, say, 5,000 cars "moved," there were only 2,500 "left in the yards." If he is content with such a showing he does not realize that this indicates an average delay of 12 hours to every car.

To be sure, it is unsafe to generalize from the cars "left over" at any one particular hour, but if this midnight figure of 2,500 cars represents the average number, the generalization is correct, and it is very easy to judge from a comparison with reports of other hours or dates whether or not an average condition is reported.

The first thing to do to get more movement for our freight cars is, then, to reduce this yard delay, which means to reduce the number of cars left in yards; and the best way to do this is to bring the facts home to everyone concerned, that is, to everyone who can help; and it is really surprising to find, when you analyze the situation on a large railroad, how many of the officers and employees can help to reduce the number of cars in yards. The superintendents, trainmasters, and yardmasters, the men who are directly responsible, are sometimes the only men who have information on the subject, but there are a great many others who can help, and will help, if the importance of the matter is explained to them. Every yard clerk can help, and a great many will if they are told exactly what is needed. The master mechanic, roundhouse foreman, and men about the roundhouse can help a great deal, and they will help if they realize that it is essential to their railroad and the railroads at large that more movement be given to freight cars. Maintenance people can help a little, and the traffic people can help a great deal. Often the president of a railroad can, and will, help if he is shown how little movement can be given to freight cars under present facilities and organization, and how much more movement can be given with improved facilities and organization.

But in distributing this information, and explaining it, we must be sure that it is information and not misinformation. As already indicated, many managers are satisfied with average conditions because they do not know exactly what their reports mean. It is easy, as I have indicated, to ascertain the approximate delay to cars from the reports which are currently made, but it is a very laborious and difficult task on a large railroad to show actually the average delay to all the cars passing through a given yard on a given day. Still, this is something which can be figured out in the card record office, and often it has to be figured out before the men responsible for the movement can believe that the average delay is anything like what is indicated by the reports of the movement and of

cars left over. Sometimes it is easier to convince the man on the ground of the delay which is taking place in his yard by making the yard clerks check against each other the hour of arrival and the hour of departure of each car. Sometimes it is necessary to do this both in the yard office and in the car record office before those responsible are convinced of the situation.

Besides convincing ourselves of what our current reports show, we should be very careful to make sure that these reports fully cover the situation, and this requires constant vigilance. It is a great temptation to everyone to make a favorable report of his own work, and it is so easy for a man on the ground to forget to report a few cars here or there, that it is really necessary to check up all car reports.

There are various ways of doing this. The car record office is useful, and so are regular trips of inspectors, but nothing is more effectual in the way of getting correct reports than for the officers to make it plain in their trips over the roads that they frequently consult and act upon the reports of cars on hand and of cars forwarded.

One special point must be looked after by the management, and this is that there be no confusion as to responsibility for car reports. It should be definitely decided exactly who is to make the car report for each siding. There is sometimes a question whether the agent, the yardmaster, or the master mechanic should make this report, and this is a question which should be gone over periodically so as to make sure, in changes of clerks, that no siding is missed, and the daily report is made complete. This may sometimes involve a decision as to whether cars awaiting movement to shop are to be counted as shop cars or not. Unless such points are fully decided some cars may not get reported at all, and on the other hand, an undue zeal may lead to duplication.

Points of interchange must be looked after especially, and the daily report of cars on hand should show the cars standing on interchange tracks for movement by the home road. A supplementary report should be made of all cars standing on interchange tracks for foreign roads, with the number of cars moved away each day. If this precaution is neglected there is danger of an unexpected accumulation or congestion. It is desirable to check these reports of cars on interchange tracks periodically with connecting roads. When this is regularly done many misunderstandings at junction points are avoided.

It is useful to have the card waybills stamped with the hour of arrival in every yard. By this device the delay to every loaded car in the yard can be readily ascertained by an inspection of the card waybills in the yard office.

Special precautions, also, should be taken to prevent delay to empty cars even in times of car shortage, as local shippers and agents are always anxious to hold a few cars for prospective loading.

It is a mistake to unduly elaborate records and statistics. The reports ordinarily in use on American railways are sufficient to give information as to the situation if they are fully and correctly made up and properly understood. After this it becomes a question of organization and discipline.

There is one other matter, however, which cannot be neglected if we are to have more movement for our freight cars. The roads must have plenty of freight engines, and the engines must be in good repair. It must be understood that a train of cars, even of empty cars, is worth more than an engine, and its delay costs more than the delay to an engine. Cars, therefore, should not wait for engines, but engines should always be ready when a train is ready.

**EARNINGS OF SOUTH MANCHURIA RAILWAY.**—The annual meeting of the South Manchuria Railway was held at Tokyo on June 14. During the fiscal year ended March 31, 1913, the company's gross revenue amounted to \$16,705,900 and expenditures to \$14,252,800, increases of \$2,684,600 and \$2,057,900 respectively over the previous year.

**HOWARD ELLIOTT.**

Howard Elliott, president of the Northern Pacific, on July 25 was elected president and director of the New York, New Haven & Hartford, as the selection of the special committee of directors appointed to choose a successor to Charles S. Mellen. The election becomes effective on September 1, but it is announced that at a meeting of the directors some time in October it is proposed to make a change in the by-laws of the company, under which Mr. Elliott will be elected chairman of the board of the entire New Haven system, and that each of the principal constituents of the system, the New York, New Haven & Hartford, the Boston & Maine, the New England Navigation Company, and the trolley line system, will have individual presidents. The new administrative plan conforms with recommendations of a committee of stockholders headed by George von L. Meyer. In becoming president of the New Haven, Mr. Elliott for the second time follows in Mr. Mellen's footsteps, having succeeded him as president of the Northern Pacific in 1903, when Mr. Mellen left that road to go to the New Haven.

Mr. Elliott seems to be an excellent choice for dealing with the very difficult railway situation in New England. He is a native of the East, having been born in New York City. While his railway career has been spent on western lines, he will find himself perfectly at home in New England, for he received his education at Harvard University, having graduated from the Lawrence Scientific School in 1881 with the degree of C. E. One of the things that got Mr. Mellen into trouble was his undiplomatic way of talking to and dealing with people. His biting sarcasm and disregard for other people's feelings and opinions made him innumerable enemies. Mr. Elliott is so differently constituted that he would be incapable of making enemies in this way, either for himself or for a railway that he was managing. He is naturally reserved, but, in spite of this, has made a practice in recent years of delivering numerous public addresses on railway subjects. In his personal relations with patrons of the road and in his public addresses he has been moderate, conciliatory and patient. He is an extremely sincere and earnest man, who leaves this impression on all with whom he comes in contact, whether in a business way or otherwise, and it seems to be a safe prediction that he will very soon win the regard and complete confidence of the people of New England both by what he says and by what he does. He accepts unreservedly the modern principle that railways and their officers are public servants, and tries to live up to this theory both in his utterances and in his management.

As a railway executive, he is one of the leaders of the country. He learned the business on the Burlington, from which so many able and successful railway managers have been graduated. He has served at different times in the engineer-

ing, the accounting, the traffic and the operating departments, and few men know both the theory and practice of railway operation and management so thoroughly. He is a tireless worker, a master of details, and an excellent organizer. He makes his plans far ahead, and is indomitably persevering in carrying them out. He has had a difficult situation to deal with throughout his career on the Northern Pacific. The road when he took charge of it was not in very good physical condition, and he very greatly improved it. Its mileage was 5,111 miles, and he increased it to 6,032 miles. Its revenue freight train load was 326 tons, and he increased it in 1912 to 511 tons. It looked as if the Northern Pacific was hard hit when the Chicago, Milwaukee & St. Paul built its extension to Puget Sound right through the Northern Pacific territory, and the Northern Pacific did feel severely for some time the effects of this new competition, but Mr. Elliott sturdily met the issue, fought a

good fight, maintained the road's dividend, and at the same time made large expenditures from earnings for improvements. In spite of the adverse conditions he was able to show a surplus of over \$3,000,000 in 1911, and one of over \$2,000,000 in 1912. When George J. Gould retired as president of the Missouri Pacific in 1911 Mr. Elliott was offered the presidency of that road, but declined it.

The foregoing indicates in a very inadequate way the manner of man who has now been given the task of solving the New England railway problem. If the owners of the New England railroads and the people of New England will give him a fair chance Mr. Elliott will do a great work for them, and his personality and his methods are such that it would seem they should command the respect and support of both the owners and the patrons of these railways.

Mr. Elliott has always taken active part in the social and business life of the cities in which he has resided, and has also by acting in co-operation with various organizations, aided in the conservation movement, and materially forwarded the agricultural interests of the West.

He was born December 6, 1860, in New York, and entered railway service during the summer of 1880, during his college vacation, as a rodman on the Chicago, Burlington & Quincy. After his graduation from Lawrence Scientific School in 1881, he became, on October 17, clerk in the president's office of the St. Louis, Keokuk & Northwestern, and during the following year for several months was clerk in the assistant treasurer's office of that road at Keokuk. From September 15, 1882, to January 1, 1887, he was assistant auditor and assistant treasurer of the Chicago, Burlington & Kansas City and the St. Louis, Keokuk & Northwestern at Keokuk. From January 1, 1887, to May 1, 1891, he was general freight and passenger agent of the same roads, and from the latter date to January 1, 1896, also of the Hannibal & St. Joseph and Kansas City, St. Joseph & Council Bluffs. From January 1, 1896, to May 1, 1902, he



Howard Elliott.

was general manager of the same roads, and from May 1, 1902, to October 21, 1903, second vice-president of the Chicago, Burlington & Quincy. On the latter date he was elected president of the Northern Pacific, and he is also president of various subsidiary companies of the Northern Pacific.

### AMERICAN RAILWAY TOOL FOREMEN'S ASSOCIATION.

The first two sessions of the fifth annual convention of the American Railway Tool Foremen's Association were reported in last week's issue, page 158. Following is a report of the last session of the convention:

#### FORGING MACHINE DIES.

B. Henrikson, Chicago & North Western, Chicago, Ill., chairman of the committee, in discussing the best material from which to make the dies, stated that cast iron, being the cheapest material and most easily worked, is very desirable for dies, but can only be used where the demand for its product is not very great. Where many forgings are required the dies should be made of cast steel. In cases where more wear takes place on one part of the die than on another the main body may be made of cast iron with a steel insert for the place where the excessive wear comes. These inserts may be replaced when worn beyond a certain limit. Nickel steel is used for heavy plunger work, while common tool steel or special plunger steel will do for lighter work. Care should be taken that the design of the dies allows for the overflow of the excess metal.

Charles Helm, Chicago, Milwaukee & St. Paul, Milwaukee, Wis., also a member of the committee, exhibited drawings of dies used on a 4 in. Ajax forging machine for forging castle nuts.

*Discussion.*—It would seem that the opportunities of the forging machine were practically unlimited, as with a good die maker many of the articles that are now made by hand in the smith shop may be more easily and less expensively made on a forging machine. The constant study of methods in the various shops will present an opportunity for the tool foremen to greatly reduce the shop operating expenses by designing tools for doing special work. Many of the members are using tire steel for the base of dies with tool steel inserts for the parts that receive the worst treatment. Cast iron is also used with steel inserts with considerable success. As a general proposition it seemed that it was not economical to use a high grade of steel in the dies, as the difference in the service between it and the cheaper steel does not warrant its use. Nickel steel was mentioned by many as giving good results for plungers and inserts. While high speed steel has also been used for this purpose it was found that it will not give service where water is used for cooling; when water is not used it will give excellent results, especially in doing work in which the plunger becomes red hot. A few members spoke of punching the tell-tale holes in the staybolts, but it was stated that this would tend to crystalize the metal in the center and harden it, thereby reducing its ductility and increasing the chance of its breaking. On the Central of Georgia chrome nickel is used for the punches or rams, and an air blast is used to remove the scale rather than a stream of water. This has given very good results.

#### THREAD AND TAPER FOR BOILER STUDS.

A. M. Roberts, Bessemer & Lake Erie, Greenville, Pa., chairman of the committee, recommended the U. S. standard form of thread for boiler studs and plugs for the following reasons: Convenience of manufacturing the studs, simplicity of application; it will give a steam tight fit from inside to outside; it will allow for a stronger and more durable stud; taps and dies may be maintained better and may be easily duplicated, and the old style of V-thread may be changed to the U. S. standard without difficulty. He also recommended a 1¼ in. taper

in 12 in. for standard mud plugs, and ¾ in. taper for studs.

J. E. Dossier, Southern Railway, Knoxville, Tenn., recommended the U. S. standard form of thread as it gives much greater strength and life to the taps and dies than the old V-thread.

Daniel Freyler, Illinois Central, Memphis, Tenn., recommended the old V-thread as standard for boiler studs and plugs, stating that it gave better holding power in the boiler and that it would adapt itself more readily to slight variations in the angle of the thread and still make a tight joint. He also recommended the ¾ in. taper in 12 in.

H. C. Wilson, Southern Railway, Spencer, N. C., reported in favor of the U. S. standard thread as it does not have the sharp point which has been found to wear away so fast on the old type of V-thread. He also found that the old V-thread form of tap or die soon wears off at the point of the thread, losing its size and form, causing trouble from tight or loose bolts.

W. J. Eddy, inspector of machinery, Rock Island lines, Chicago, recommended U. S. standard thread with ¾ in. taper for plugs and fittings, and 1¼ in. taper for washout plugs. In all cases 12 threads per inch was recommended.

*Discussion.*—A recommendation was passed as the sense of the association that all boiler fittings be made with a ¾ in. taper and the U. S. standard thread with 12 threads to the inch. This recommendation was adopted after considerable discussion. It was clearly pointed out that with the V-thread the taps were harder to keep in proper condition, and that a good steam tight fit could not be made as easily as with the U. S. standard tap. It was pointed out that the U. S. standard would be more economical and give greater satisfaction. The Whitworth thread was mentioned by many as giving the best satisfaction for the staybolts, but was more difficult to maintain than the U. S. standard thread.

A. R. Davis, of the Central of Georgia, reported that from tests he had found that it took 24 per cent. less power to tap a hole with a U. S. standard tap than with a V-thread tap. He also found in tapping 25 holes that the wear on a V-thread tap was .008 in., while on a U. S. standard tap it was .001¾ in. In another test of 50 holes the V-thread had worn away .011 in., while the U. S. standard had only worn .003 in. A lubricant of lead and oil was used. The condition of the tap holes showed that 20 per cent. of those tapped with the U. S. standard thread was better than those tapped with the V-thread.

#### OTHER BUSINESS.

The following officers were elected for the ensuing year: President, A. M. Roberts, Bessemer & Lake Erie, Greenville, Pa.; first vice-president, Henry Otto, Atchison, Topeka & Santa Fe, Topeka Kan.; second vice-president, J. J. Sheehan, Norfolk & Western, Roanoke, Va.; third vice-president, E. R. Purchase, Boston & Albany, Springfield, Mass.; secretary-treasurer, A. R. Davis, Central of Georgia, Macon, Ga.; chairman of executive committee, C. A. Shaffer, Illinois Central, Chicago, Ill. The following four men were also elected to the executive committee: J. Martin, Cleveland, Cincinnati, Chicago & St. Louis, Indianapolis, Ind.; O. D. Kinsey, Illinois Central, Chicago, Ill.; C. Helm, Chicago, Milwaukee & St. Paul, Milwaukee, Wis.; A. Williams, Pennsylvania Railroad, Ft. Wayne, Ind. There were 56 members registered.

**PROPOSED CHANGSAN-YUSAN RAILWAY, CHINA.**—The proposal of the managing director of the Chekiang Railway, to construct the short line connecting Changsan, in Chekiang, and Yusan, in Kiangsi, has received enthusiastic response, and some definite action has been taken toward the carrying out of the project. This line, short though it is, will be a connecting link, greatly needed, between the grand routes of the two provinces to Anhui and northward on the one hand, and to Fukien and Kwangtung on the other hand.

**JAMES H. HUSTIS.**

Under the plan by which Howard Elliott is to become temporarily president of the New York, New Haven & Hartford until the by-laws of the company can be changed to provide for the office of chairman of the board, James H. Hustis, vice-president of the Boston & Albany, is to become, subject to the approval of the board on November 1, president of the New York, New Haven & Hartford. There is not another man prominent in the railroad field who could take the presidency of the New Haven with so much of the confidence of the New England people already behind him as Mr. Hustis. When in October, 1907, James H. Hustis came to the Boston & Albany as assistant general manager—the title of general manager being retained by the general manager of the New York Central, but the duties on the Boston & Albany devolving on Mr. Hustis—it is not much of an exaggeration to say that the Boston & Albany was a by-word for unsatisfactory service in New England. With patience and honesty that inspired public confidence, and the courage of his convictions that gained from the New York Central management a larger and larger share of the final authority in the management of the Boston & Albany, he has brought the service on the B. & A. up to a standard that is not only satisfactory to New England, but is a model for the rest of the country.

Mr. Hustis is sometimes spoken of as being a blunt man. He is blunt in the sense that he is keen, honest, confident in his own honesty and intolerant of subterfuge. He is also intolerant of shirking the responsibilities which go with authority. An instance that well illustrates this point occurred not so very long ago on the Boston & Albany. An engineman had backed his train off a siding which until a few days before had been connected with another track. The engineman was suspended for a considerable period of time and report was made which in the course of time reached Mr. Hustis showing that the engineman alone was responsible, since he had failed to read the bulletin describing the condition of the siding. Mr. Hustis at once refused to accept this report as complete, and insisted that not only was the engineman at fault, but that a share of the responsibility rested also on the men who should have made sure that the engineman read his bulletin and the switchman who knew of the condition of the track and did not especially warn the engineman and on the officers who had not taken every precaution in their power to see that just such an occurrence as this should not happen.

In cases of complaint where the complaints were addressed to the general manager it is invariably the practice for Mr. Hustis to acknowledge the letter of complaint at once, where possible to explain the occurrence complained of immediately, and whenever the complainant was a resident of Boston, or

likely to be in Boston, he was invited to come into the office and talk the situation over. Naturally in a great majority of cases where this invitation was availed of, the critic was turned into a staunch friend.

Mr. Hustis is a member of the board of directors of the First National Bank of Boston and of the Newton Trust Company, his home town. He is also a member of the Boston Chamber of Commerce. By thus actually entering in personally with the interests of those served by his road he has identified himself with the interests of New England, not as an outsider, nor even as an acquaintance, but as a friend.

It seems peculiarly fortunate, or possibly we may lay it to the genius of doing the right thing that seems to attach to Mr. Vail, that the New Haven directors were able to secure in one and the same man qualities which will go so far toward restoring a proper feeling between the New Haven and the New

England people, and qualities which are so badly needed in the New Haven labor situation. Mr. Hustis is a strict disciplinarian, and one of his early decisions on the Boston & Albany was to discharge an employee who had merited such discipline, but who happened to be the leader of one of the strongest labor unions on the road, and in spite of this, or possibly because of it, he has gained to an unusual degree the sincere respect of his men as well as his subordinate officers.

Combined with his inflexibility in the face of breaches of discipline, he has a broad, human toleration for other people's ways of doing things. In commenting on the work of a superintendent, once, who had been in the habit of doing things his own way, and his own way was not always the best way, Mr. Hustis remarked that as he had more and more experience in the handling of men, he had come to the conclusion that the line which divides right and wrong for each individual is not a straight line, rigid and unbendable, but is a line which is balanced with deviations on one side, counterweighing deviations on the other.

Mr. Hustis has a power of quick analysis, of quick judgment of character, and of quickly arriving at decisions, that brings out the best in his employees without ever suggesting the "driver." It is said, and probably with literal truth, that there is hardly a minor officer on the Boston & Albany who does not "cherish a speaking acquaintance with Hustis." In other words, he has that rare quality in an executive of commanding the respect of his subordinate, while never for an instant standing aloof from him. Not long after Mr. Hustis had taken the Boston & Albany, in speaking of his own work he said: "It is the men at the switches, on the trains, in the yards that do the real work. All that I can do is to try to find out where the weak points are and try to strengthen them."

James H. Hustis was born in New York City in 1864, and began railroad work as office boy in the general manager's office of the New York Central & Hudson River. In 1891 he was



James H. Hustis.

appointed trainmaster on the Harlem division, and two years later was made assistant superintendent. In 1900 he was appointed superintendent of the Harlem division, was later made superintendent of the River division (the West Shore), and served as superintendent of the Rome, Watertown & Ogdensburg, of the Hudson division and of the Putnam division. In 1907 he was made general superintendent of the western district, and in October of the same year was given charge of the Boston & Albany with the title of assistant general manager. In June, 1911, he was given the title of vice-president, and the operation of the Boston & Albany was put entirely in his charge.

### STATISTICS OF RAILWAYS FOR THE YEAR ENDED JUNE 30, 1912.

This abstract is based upon compilations covering the fiscal year ended June 30, 1912, made from the annual reports of carriers having gross operating revenues of \$100,000 or more for the year and also of railway companies owning property operated by the same carriers under lease or other agreement, which have been made in advance of the completion of the twenty-fifth annual statistical report of the Interstate Commerce Commission. The omission of returns for small roads prevents the showing of items comparable with complete figures for 1911. None of the statements include returns for switching and terminal companies. The figures given in the abstract may be somewhat modified by revision before they are presented in the full report for 1912.

#### MILEAGE.

On June 30, 1912, the roads covered by this abstract represented 240,239 miles of line operated, including 10,825 miles used under trackage rights. The aggregate mileage of railway tracks of all kinds covered by operating returns for these roads was 360,714 miles. There were single track, 240,239 miles; second track, 24,930; third track, 2,512; fourth, fifth and sixth tracks, 1,784; yard track and sidings, 91,250. These figures indicate, for the roads under consideration, an increase of 8,926 miles over corresponding returns for 1911 in the aggregate length of all tracks, of which increase 3,167 miles, or 35.49 per cent., represent yard track and sidings.

#### EQUIPMENT.

There were 61,250 locomotives in service on June 30, 1912, an increase of 979 over the previous year. Of the total number of locomotives, 14,206 were classified as passenger, 36,600 as freight, 9,475 as switching, and 969 were unclassified.

The total number of cars of all classes in the service of such roads was 2,368,658 (or 25,245 more than on June 30, 1911), which equipment was assigned as follows: Passenger service, 50,606 cars; freight service, 2,203,128; company's service, 114,924. The figures given do not include so-called private cars of commercial firms or corporations. Of cars in freight service, there were classified 2,202,966, as follows:

Type	Number.	Aggregate capacity in tons.
Box	1,002,461	33,975,288
Flat	146,050	4,990,796
Stock	76,392	2,333,976
Coal	852,720	36,588,734
Tank	7,795	310,348
Refrigerator	30,681	950,530
Other cars in freight service	86,867	3,498,287
<b>Total</b>	<b>2,202,966</b>	<b>82,647,959</b>

The average number of locomotives per 1,000 miles of line was 255, and the average number of cars per 1,000 miles of line, 9,860. The number of passenger-miles per passenger locomotive was 2,263,019, and the number of ton-miles per freight locomotive was 7,077,428.

The number of locomotives and cars in the service of the carriers under consideration aggregated 2,429,908, of which 2,410,440, or 99.20 per cent. as against 99.01 per cent. in 1911, were

fitted with train brakes, and 2,425,265, or 99.81 per cent. as against 99.77 per cent. in 1911, were fitted with automatic couplers. Of the 2,203,128 cars in freight service on June 30, 1912, the number fitted with train brakes was 2,194,694 and the number fitted with automatic couplers was 2,199,301.

#### EMPLOYEES.

The total number of persons reported as on the pay rolls was 1,699,218, or an average of 707 per 100 miles of line. As compared with corresponding returns for June 30, 1911, there was an increase of 45,987. There were 63,558 enginemen, 66,408 firemen, 49,051 conductors, 135,959 other trainmen, and 39,530 switch tenders, crossing tenders, and watchmen. The total amount of wages and salaries reported as paid to railway employees during the year ended June 30, 1912, for the roads under consideration was \$1,243,113,172.

#### CAPITALIZATION OF RAILWAY PROPERTY.

On June 30, 1912, according to the annual reports under consideration, the par value of the capital outstanding was \$19,533,750,802. This amount includes capital held by the railway companies concerned, as well as by the public. Of the total amount of such capital outstanding there existed as stock \$8,469,560,687, of which \$6,882,813,008 was common and \$1,586,747,679 was preferred; the remaining part, \$11,064,190,115, representing funded debt, consisted of mortgage bonds, \$8,019,700,886; collateral trust bonds, \$1,279,128,266; plain bonds, debentures, and notes, \$1,067,567,350; income bonds, \$263,441,054; miscellaneous funded obligations, \$116,170,300; and equipment trust obligations, \$318,182,259.

Of the total capital stock outstanding, \$2,909,693,873, or 34.35 per cent., paid no dividends. The amount of dividends declared during the year (by both operating and non-operating companies represented in this statement) was \$400,432,752, or 7.20 per cent., on dividend-paying stock. The average rate of dividends paid on all stocks outstanding pertaining to the roads under consideration was 4.73 per cent. No interest was paid on \$808,464,701, or 7.52 per cent., of the total amount of funded debt outstanding other than equipment trust obligations.

#### INVESTMENT IN ROAD AND EQUIPMENT.

The expenditures for additions and betterments, as well as the expenditures for new lines and extensions, during the fiscal year 1912 were as follows:

Investment to June 30, 1912	\$15,895,657,969	
Investment to June 30, 1911	15,518,264,612	
<b>Increase 1912 over 1911</b>		<b>\$377,393,357</b>
Expenditures for additions and betterments		Expenditures for new lines and extensions
From cash or other working assets	\$187,976,646	\$59,872,304
From special appropriations	32,553,291	183,613
Through issue of securities	113,592,193	124,498,432
Unassigned	2,134,855	3,554,933
<b>Total</b>	<b>\$336,256,985</b>	<b>\$188,109,282</b>
Total expenditures during year		\$524,366,267
Property retired or converted	\$67,371,604	
Adjustments	17,290,466	
Difference between record value of grantor and purchase price of grantee in case of roads sold, merged, consolidated, etc.	62,310,840	
<b>Total</b>		<b>146,972,910</b>
<b>Net increase during year</b>		<b>\$377,393,357</b>

#### PUBLIC SERVICE OF RAILWAYS.

The number of passengers carried during the year was 994,158,591. The corresponding number for the year ended June 30, 1911, was 987,710,997. The increase in the number of passengers carried during the year over corresponding returns for 1911 was 6,447,594.

The passenger mileage was 33,034,995,806. The corresponding return for 1911 was 73,465,336 more. The passenger mileage per mile of road was 139,356, as against 142,859 for the preceding year.

The number of tons of freight carried (including freight received from connections) was 1,818,232,193, while the corresponding figure for the previous year was 1,753,189,939, the increase being 65,042,254.

The ton mileage was 262,955,605,123. The corresponding ton mileage as reported for the year ended June 30, 1911, was 253,456,389,237. The increase in the ton mileage over 1911 was 9,499,215,886. The number of tons carried one mile per mile of road was 1,108,578, as against 1,088,314 for 1911. The average number of tons of freight per train-mile was 409. The corresponding figure for the preceding year was 386.

The average receipts per passenger per mile, as computed for the year ended June 30, 1912, for the roads covered by this statement, were 1.985 cents; the average receipts per ton per mile, 0.743 cent. The passenger service revenue per train-mile was \$3.04.015. The average operating revenues per train-mile were \$2.30.201. The average operating expenses per train-mile were \$1.59.544. The ratio of operating expenses to operating revenues was 69.30 per cent.

REVENUES AND EXPENSES.

The operating revenues of the railways herein represented (average mileage operated 237,809 miles) were \$2,826,917,967; their operating expenses were \$1,958,963,431. The corresponding returns for 1911 (average mileage operated 234,366 miles) were: Operating revenues, \$2,772,733,828; operating expenses, \$1,901,399,475. The following figures present a statement of the operating revenues for 1912 in detail:

Freight revenue .....	\$1,956,802,927
Passenger revenue .....	657,422,999
Excess baggage revenue .....	7,473,128
Parlor and chair car revenue .....	658,800
Mail revenue .....	50,674,758
Express revenue .....	72,970,758
Milk revenue (on passenger trains) .....	8,323,683
Other passenger revenue .....	5,228,969
Switching revenue .....	29,331,726
Special service-train revenue .....	2,078,910
Miscellaneous transportation revenue .....	6,174,062
Total revenue from operations other than transportation .....	27,367,678
Joint facilities—Dr. ....	—918,586
Joint facilities—Cr. ....	3,328,155

Total operating revenues..... \$2,826,917,967

Operating expenses, as assigned to the five general classes, were:

Maintenance of way and structures.....	\$363,495,583
Maintenance of equipment.....	448,303,785
Traffic expenses .....	60,568,586
Transportation expenses .....	1,013,340,697
General expenses .....	73,254,780

Total operating expenses..... \$1,958,963,431

With minor eliminations from the figures given above, operating revenues per mile of line operated averaged \$11.881 and operating expenses \$8.234 for the year.

CONDENSED INCOME ACCOUNT AND PROFIT AND LOSS ACCOUNT.

There is given below a condensed income account and profit and loss account of operating roads, the gross operating revenues of which were \$100,000 or more for the year ended June 30, 1912. A similar statement follows for non-operating roads (leased, operated under contract, etc.) controlled by the operating roads described. The statements omit returns for a few roads, the reports of which were not sufficiently complete for inclusion therein. For a number of items, such as dividends, taxes, etc., both statements must be taken into consideration in order to learn the aggregates of such items. Thus the aggregate of dividends declared during the year, \$400,308,609, includes those declared out of current income and those declared from surplus both by the operating roads and by the non-operating roads. This amount includes dividends declared on railway capital stock owned by other railway companies.

OPERATING ROADS.  
Income Account.

Rail operations:	
Operating revenues .....	\$2,826,917,967
Operating expenses .....	1,958,963,431
Net operating revenue .....	\$867,954,536

Outside operations:	
Revenues .....	\$63,527,073
Expenses .....	62,489,614
Net revenue from outside operations.....	1,037,459
Total net revenue .....	\$868,991,995
Taxes accrued .....	113,122,509
Operating income .....	\$755,869,486
Other income .....	255,611,495
Gross income .....	\$1,011,480,981
Rents, interest, and similar deductions from gross income.....	609,661,490
Net corporate income .....	\$401,819,491
Disposition of net corporate income:	
Dividends declared from current income.....	\$246,372,011
Appropriations for additions and betterments.....	37,186,102
Appropriations for new lines and extensions.....	77,082
Appropriations for other reserves.....	5,463,269
Total .....	289,098,464
Balance to credit of profit and loss.....	\$112,721,027
<i>Profit and Loss Account.</i>	
Credit balance on June 30, 1911.....	\$1,065,793,723
Credit balance for year 1912 from income account.....	112,721,027
Total .....	\$1,178,514,750
Dividends declared out of surplus.....	100,433,571
Difference .....	\$1,078,081,179
Appropriations for additions and betterments.....	\$4,274,626
Appropriations for new lines and extensions.....	106,542
Appropriations for other reserves.....	3,020,920
Other profit and loss items—debit balance.....	16,449,742
Total .....	23,851,830
Balance credit June 30, 1912, carried to balance sheet....	\$1,054,229,349

NON-OPERATING ROADS.

Income Account.

Gross income from lease of road.....	\$124,533,101
Salaries and maintenance of organization.....	352,898
Taxes accrued .....	6,777,870
Net income from lease of road.....	\$117,402,333
Other income .....	6,495,874
Gross income .....	\$123,898,207
Interest, and similar deductions from gross income.....	69,754,356
Net corporate income .....	\$54,143,851
Disposition of net corporate income:	
Dividends declared from current income.....	\$37,556,473
Appropriations for additions and betterments.....	1,067,278
Appropriations for new lines and extensions.....	16,943
Appropriations for other reserves.....	16,783
Total .....	38,657,477
Balance to credit of profit and loss.....	\$15,486,374
<i>Profit and Loss Account.</i>	
Credit balance on June 30, 1911.....	\$66,257,339
Credit balance for year 1912 from income account.....	15,486,374
Total .....	\$81,743,713
Dividends declared out of surplus.....	15,946,554
Difference .....	\$65,797,159
Appropriations for additions and betterments.....	\$1,173,439
Appropriations for new lines and extensions.....	.....
Appropriations for other reserves.....	115,000
Other profit and loss items—debit balance.....	11,117,804
Total .....	12,406,243
Balance credit June 30, 1912, carried to balance sheet....	\$53,390,916

UNIFICATION OF CHINESE RAILWAY ACCOUNTS.—Dr. C. C. Wang has gone to Europe in company with Mr. Tsang Kuang-hsiang, inspector general of railways, to study the various systems of accounting in vogue in various countries. They will be gone several months, and their investigations should lead to great benefits to China in future. Dr. Wang's mission is not likely to be as resultless as many other missions which China has from time to time sent abroad.

KIRIN-CHANGCHUN RAILWAY, CHINA.—The biggest towns on this line are Kirin and Changchun, which, although they are trading marts, do not possess the qualities of such extensive development as is possible with a port accessible both by land and water routes. If the railway is prolonged to the bank of the Sungari river it will be connected with the water route and there will be great developments possible because of the increased facilities. After completion the receipts of the line will be materially increased. The Minister of Communications has approved this proposal.

TRAIN ACCIDENTS IN JUNE.<sup>1</sup>

Following is a list of the most notable train accidents that occurred on railways of the United States in the month of June, 1913:

Collisions.					
Date.	Road.	Place.	Kind of Accident.	Kind of Train.	Kil'd. Inj'd.
1.	Boston Term.	Boston.	xc.	P. & P.	1 0
2.	N. Y., N. H. & H.	North Kent.	bc.	F. & F.	1 1
3.	Boston & M.	S. Lawrence.	xc.	P. & P.	0 20
12.	N. Y., N. H. & H.	Stamford.	rc.	P. & P.	6 22
18.	Lake Shore & M. S.	Kalamazoo.	bc.	P. & F.	2 37
22.	Chi., Mil. & St. P.	Delmar J.	rc.	F. & F.	3 1
27.	N. Y., N. H. & H.	Canaan.	xc.	P. & F.	0 8
	C. N. E.				

Derailments.					
Date.	Road.	Place.	Cause of Derailm't.	Kind of Train.	Kil'd. Inj'd.
1.	Great Northern	Barnesville.	neg.	P.	1 19
1.	C., C., C. & St. L.	Stockwell.	b. journal.	F.	2 5
18.	M., Kan. & Tex.	Hailey.	acc. obst.	P.	1 53
18.	Boston & M.	Graniteville.	unx.	P.	0 1
20.	Mobile & O.	Wickliffe.	d. track.	P.	0 1
22.	Pennsylvania	Cuylerville.	d. track.	P.	0 38
23.	Del. & Hudson	Minooka.	exc. speed.	F.	2 1
24.	Annapolis S. L.	Severnside.	runaway.	P.	0 0
28.	Ches. & Ohio	Fulton, Ind.	d. track.	P.	0 21

In the collision at the South station at Boston on the 1st, a local passenger train entering the station ran into the side of another passenger train which was coming out, and overturned one parlor car. The 15 passengers in this car all escaped with slight injuries, but a brakeman was fatally scalded. The collision was due to disregard of a signal.

The trains in collision at North Kent, Conn., on the night of the 2d were a southbound train consisting of a locomotive and two empty passenger cars and a northbound milk train. The fireman of the southbound train was killed and the engineer was injured. The cause of the collision was disregard of dispatcher's orders on the part of the southbound train.

In the collision of passenger trains at South Lawrence, Mass., on the third 18 passengers and two employees were injured, none very seriously. A passenger train consisting of two cars backing into the station from a branch was run into by one from Boston, the latter being at fault. The Massachusetts Railroad Commission, reporting on the collision, ordered the abandonment of ball signals (not interlocked).

The trains in collision at Stamford, Conn., on the 12th were westbound express No. 53, first and second sections. The first section had been stopped for a change of engines and was run into by the second section, which had passed distant and home signals set against it. This collision was reported in the *Railway Age Gazette* of June 20 and 27; and the Interstate Commerce Commission's report is noticed in the issue of July 15. Six passengers were killed.

The butting collision at Kalamazoo, Mich., on the 18th was between a northbound passenger train and a southbound work train, and both engines were badly wrecked. Two employees were killed and 31 passengers and 4 trainmen were injured. The collision was due to disregard of rules on the part of the work train, which encroached on the right of the passenger train.

The trains in collision near Delmar Junction, Iowa, on the 22d were eastbound freight train No. 70 and a work train engaged in distributing material. One engine and twenty cars were damaged. Three trespassers in a box car were killed and one was injured. The collision was due to the wrongful assumption, on the part of No. 70, that the block section was clear, after having received notice that the section was occupied by the work train.

The trains in collision at Canaan, Conn., on the 23rd of June, were a southbound milk train of the N. Y. N. H. & H. and an eastbound freight of the Central New England, the collision oc-

curing at the crossing of the two roads. Eight passengers in the coach of the milk train were injured. The passenger car of the milk train was backed into the freight train, on the crossing, when the front part of the train was coupled to the rear part.

The train derailed near Barnesville, Minn., on the evening of the 1st was the westbound Oriental limited express and the engine and first three cars were overturned. The engineer was killed and six employees and 13 passengers were injured. The cause of the derailment was disregard of a signal at an interlocking.

The train derailed near Stockwell, Ind., on the 1st was a westbound freight, and 12 loaded cars were wrecked. Two trespassers riding on the cars were killed and five others were injured. The cause of the derailment was a broken journal.

The train derailed on the Missouri, Kansas & Texas, at Hailey, Okla., on the 8th, was southbound passenger No. 9, and four of the cars were wrecked. One passenger was killed and fifty passengers and three trainmen were injured. The wreck occurred at 3 a. m. and was caused by striking four horses which were on the track. One of the horses was thrown against a switch stand with such force as to break the connection to the rails and throw a car off the track.

The train derailed near Graniteville, Mass., on the 18th was an express train bound from New York City to Bar Harbor, and seven of the nine cars in the train ran off the track. Of the 75 passengers in the train all escaped without serious injury. One employee was injured. The cause of the derailment is reported as not fully determined; the tender was the first vehicle to leave the track.

The train derailed near Wickliffe, Ky., on the 20th was a northbound passenger. One sleeping car was overturned and its conductor was injured. The cause of the derailment was distortion of track by solar heat.

The train derailed at Minooka, Pa., on the 23d consisted of a locomotive only, and it is said that the cause of derailment was excessive speed on a curve. The engineer was killed, and also a fireman riding on the engine, deadhead; and the fireman of the engine was injured.

The train derailed near Cuylerville, N. Y., on the 22d was a southbound excursion of six cars, occupied by about three hundred passengers. Four cars were ditched when the train was running over an easy curve at a moderate speed. The number of persons injured was thirty-eight, though the names of only eight are given as seriously injured. The cause of the derailment was a broken tender truck.

The train derailed on the Annapolis Short Line at Severnside, Md., on the 23d was a freight consisting of a locomotive, 5 cars and a caboose. The train became uncontrollable on a descending grade and plunged through a partly open draw and fell into the river. There were no serious injuries, though the engineer and fireman narrowly escaped.

The train derailed near Fulton, Ind., on the 28th was eastbound express No. 6, and a sleeping car and a dining car were overturned. One employee in the dining car and about twenty passengers were injured. The train was running about 20 miles an hour. The cause of the derailment was the distortion of the track by solar heat.

Canada.—Eight passengers were killed in a derailment on the Canadian Pacific, near Ottawa, on Wednesday, June 25, as reported in the *Railway Age Gazette* of July 4, page 26.

NEW TUNNEL FOR INDIA.—The scheme for a new railway tunnel on the Western Ghats Railway has now matured, and the contract for its construction has been let. It will be in the vicinity of Kasara station, between Kalyan and Igatpuri and is 75 miles from Bombay. It will be 140 ft. long, and will run nearly parallel to the old tunnel, but will be on a steeper grade and of a slightly larger area. It is expected that the work of construction will occupy about 18 months.

<sup>1</sup>Abbreviations and marks used in Accident List:  
 rc, Rear collision—bc, Butting collision—xc, Other collisions—b, Broken—d, Defective—unf, Unforeseen obstruction—unx, Unexplained—derail, Open derailing switch—ms, Misplaced switch—acc, obst., Accidental obstruction—malice, Malicious obstruction of track, etc.—boiler, Explosion of locomotive on road—fire, Cars burned while running—P, or Pass., Passenger train—F, or Ft., Freight train (including empty engines, work trains, etc.)—Asterisk, Wreck wholly or partly destroyed by fire—Dagger, One or more passengers killed.

# LONG ISLAND IMPROVEMENTS AT JAMAICA.

The Elevation of Tracks, Including the Separation of Railway Grades at Three Points, and a New Station and Office Building.

The Long Island Railroad is now completing very extensive improvements at Jamaica, L. I., involving an expenditure of about \$3,000,000. This work involves a number of unusual and very interesting problems, including, as it does, the elevation of all tracks for a distance of about two miles, the separation of grades of intersecting branches at three different points and the construction of a station and general office building. While the city of Jamaica has only 25,000 population, it is the center of the Long Island system, from which lines radiate in six different directions to the various parts of the island. It is essentially a transfer station and the number of passengers changing from one train to another at this point is very large.

The main line extends northwest to Long Island City and through the tunnels under the East river to the new Pennsylvania terminal in uptown New York, a distance of about 11 miles. The Atlantic division extends west to Flatbush station, Brooklyn, about the same distance, where connection is made with the subway for downtown New York. The Montauk division extends northwest between these two lines to Long Island City. East of Jamaica the main line extends along the center

with the general plan for the substitution of electricity for steam on all Pennsylvania lines in the vicinity of New York, the Long Island being a subsidiary of the Pennsylvania, although operated independently. At the present time all trains between Jamaica and the Pennsylvania terminal are operated by electricity as are also all passenger trains going to Flatbush avenue. At the time the subway was built to Brooklyn it was anticipated that Long Island trains would run directly into downtown New York through the subway, and the Flatbush avenue terminal was designed accordingly, but this plan has since been abandoned. The Montauk division to Long Island City and Bushwick, which handles considerable freight traffic and a few passenger trains, is still operated by steam, while several freight trains are moved daily over the Atlantic division towards Flatbush avenue by steam. Preliminary to the undertaking of the Jamaica improvements, the main freight yard was moved out to Holban, about two miles east of Jamaica, eight years ago, and freight trains are made up at this yard for movement by steam either to the transfer bridges at Long Island City or Bay Ridge, or to the eastern portions of the island.

All of the service to Brooklyn and the great bulk of the traffic to the Pennsylvania station is handled by multiple unit trains, but a few of the trains entering Jamaica from New York change from electric to steam power at the Pennsylvania's Sunnyside yard in Long Island City and proceed without breaking up. The multiple unit equipment operating west of Jamaica and the ordinary steam trains running east from Jamaica require, of course, facilities for making up the trains and also for storing and cleaning the equipment.

## TRACK ELEVATION AND GRADE SEPARATION.

The most important part of these improvements is the elevation of the tracks. In connection with this it was essential that the traffic over the various lines be separated to avoid opposing crossings at grade and the delay incident to handling over 1,000 passenger trains daily in addition to freight traffic and switching movements to and from the roundhouse and coach and team track yards. The elimination of these crossings entailed some of the most elaborate work of this nature which has ever been undertaken in this country and the arrangement adopted enables trains from any of the branches to be run into and out of the station without crossing or fouling any other line except at the switches at the ends of the station and separates all freight and passenger traffic. The natural topography at Jamaica did not influence the plans to any great extent as the country is essentially flat in the vicinity of the improvements.

To secure an idea of the magnitude of the problems involved it is necessary to study the track layout adopted and especially the arrangement of the various main lines entering the station. The two existing tracks on the Atlantic division coming east from Flatbush avenue are increased to four, the two outside tracks being devoted to local passenger service. These tracks remain on the present ground level until opposite the roundhouse, when they begin to ascend onto the elevation on a 0.7 per cent. grade, this being the standard adopted for all permanent main line approaches to the elevation. From Maure avenue the eastbound Atlantic division freight track and both passenger tracks continue on a slightly ascending grade to Van Wyck avenue, where the eastbound freight track swings to the south around the new passenger station, which is located between Foley and Guilford streets. The westbound Atlantic division freight track descends on a 1.7 per cent. grade from a connection with the Montauk division main tracks near Van Wyck avenue, to west of Maure avenue, where it joins the Atlantic division passenger tracks. The two Montauk division main tracks ascend eastwardly on a 0.7 per cent. grade im-

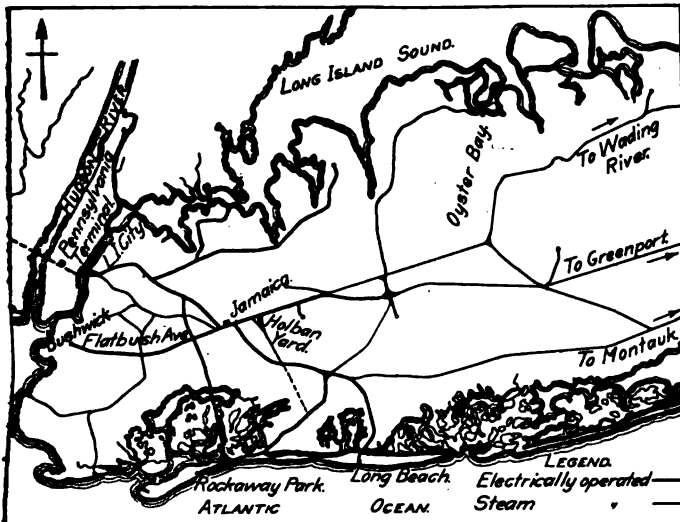

Long Island Tracks in Vicinity of Jamaica.

of the island to Greenport and to Shelter Island, with branches to Oyster Bay and Wading River along Long Island sound. The Montauk division turns south from the main line about two miles east of Jamaica and follows the south shore of the island to Montauk Point at the eastern end. The Old Southern branch turns south immediately at the station and extends to the beaches on the south shore.

The Long Island is essentially a passenger road, depending very largely upon suburban travel. Over 63 per cent. of the gross earnings are derived from passenger revenue as compared with 32 per cent. from freight. This passenger travel is largely commuter traffic, increased very greatly during the summer months. About 65,000 passengers, or two-thirds of all those carried by the Long Island for New York, are now delivered at Flatbush avenue daily, although the number going directly to the uptown terminal has grown rapidly since the completion of the new Pennsylvania station and will increase at a greater rate upon the completion of the Seventh avenue subway. The traffic is so divided that it is impossible to arrange any schedules in which a large proportion of the passengers will not have to transfer at Jamaica, and the problem at this station is therefore to facilitate this transfer as much as possible.

The improvements at Jamaica are being made in accordance



mediately after crossing Ridgewood avenue, this northerly or westerly limit of the elevation, however, being but temporary, as upon the completion of the Jamaica improvements it is intended to elevate the tracks across Ridgewood avenue for a mile farther west through Richmond Hill. Just north of the roundhouse, the westbound Montauk division track divides into two tracks for passenger and freight service respectively. These three tracks then ascend on a 0.7 per cent. grade, crossing over two tracks at Maure avenue, which leads from the Atlantic division westbound freight track to the passenger coach cleaning yard, used for movements between the roundhouse and the coach yard. The westbound passenger track then descends on a 1.7 per cent. grade to the level of the Atlantic division passenger tracks, passes under the eastbound main line tracks and enters the station. The two other Montauk division tracks continue on the high level to Van Wyck avenue, where they cross over the Atlantic division passenger tracks. Eastbound Montauk division passenger trains enter the station over the eastbound

cent. with the traffic. The main line and Montauk division tracks proceed east from the station on a 0.7 per cent. ascending grade, crossing over Rockaway Road, after which they descend to the level of the present tracks between Prospect and Washington streets.

SPECIAL STRUCTURES.

Complicated work was encountered at Van Wyck avenue, where two tracks of the main line and two of the Montauk division cross over six tracks of the Montauk and Atlantic divisions directly over the street, necessitating a three level structure costing about \$250,000. In connection with this work, Van Wyck avenue was widened from 66 ft. to 100 ft., of which 18 ft. 6 in. on each side was given over to sidewalks. The entire structure is of steel with center and curb supports, the center posts being enclosed by concrete walls for protection against damage by traffic. The vertical posts were designed to extend continuously from the footing to the upper deck and are of built-up I-beam

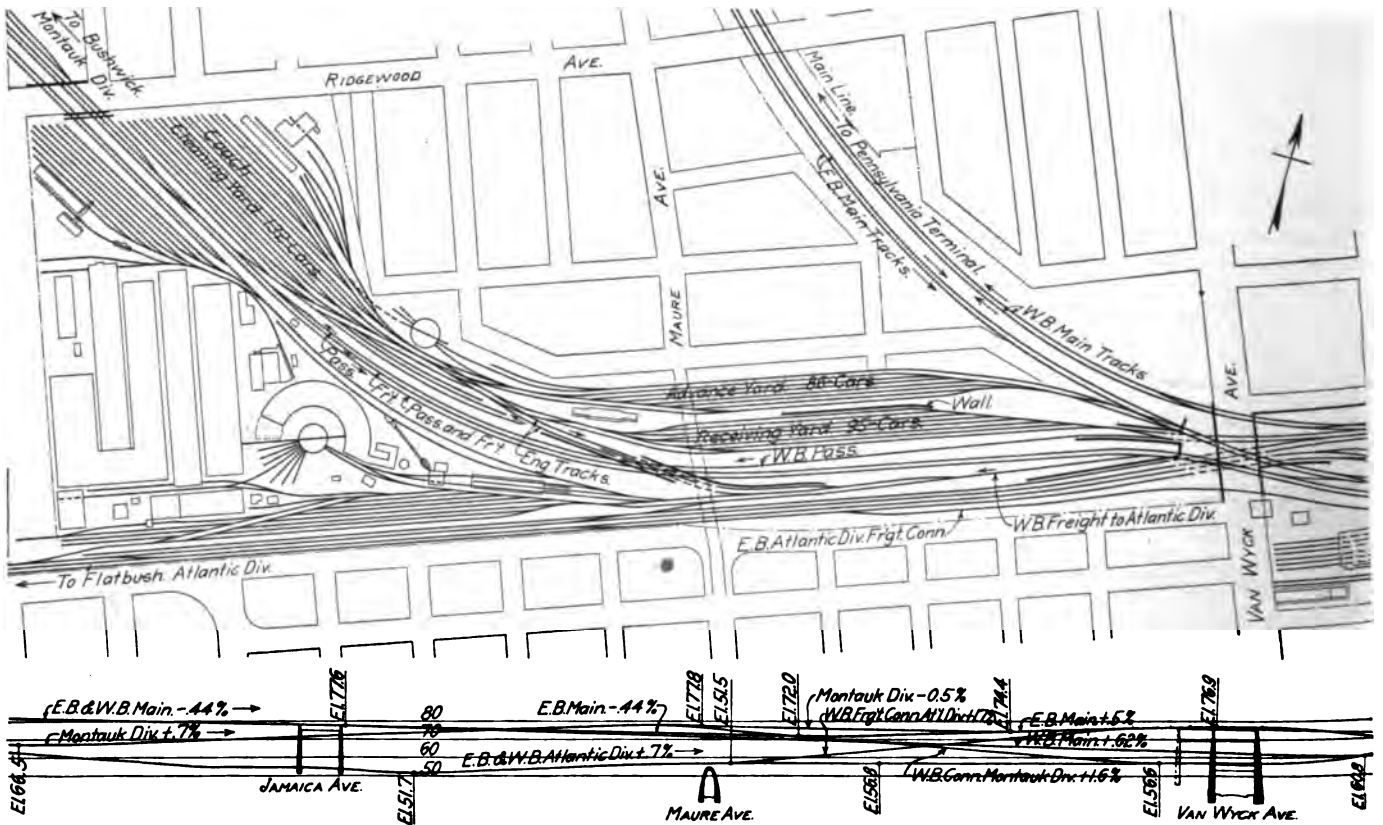

Track Layout and Profile of Complete Development at Jamaica.

main line passenger tracks through a series of cross-overs. The main line, which is used almost entirely for passenger traffic, comes in from the north with four tracks connecting with the other lines at Van Wyck avenue on a 3 deg. curve. North of Ridgewood avenue the elevation of these tracks connects with work previously completed. Entering the station, the eastbound tracks rise to the high level, crossing over the entrance to the receiving yard, and the westbound passenger connection to the Montauk division and over the four Atlantic division passenger tracks, after which they descend to the station level. The westbound main line tracks lead directly from the throat of the station on a level grade without crossing the tracks of any other division.

East of the station the principal complications arose from a connection with the Old Southern branch. Both tracks of this branch cross under the two main freight tracks and the two eastbound passenger tracks and then ascend to the level of the station between the eastbound and westbound passenger tracks on grades ranging from 2 per cent. against the traffic to 2.9 per

section 38 ft. 1 1/16 in. long, supported on steel grillage footings. The tracks on the intermediate level are carried on a solid floor of 15 in. I-beams embedded in concrete, these beams being in turn riveted to main girders 54 in. deep. A similar construction was adopted on the upper floor with the exception that the I-beams rested directly upon the upper flanges of another set of cross girders, and here concrete was used to protect the under surface of the steel floor system from the action of the gases from locomotives on the intermediate level. A clearance of 14 ft. is provided on the street level, and of 16 ft. 9 in. on the lower track level, the upper level being a deck structure.

Another special structure is that at Maure avenue, where this street is carried under tracks crossing at two different levels by a 32 ft. segmental arch. This arch is over 500 ft. long, extending under the advance and receiving yards as well as the main lines. It was constructed in short sections, each comprising about 200 yd. of concrete placed as the elevation of the tracks progressed, steel forms being used and moved from one section to another. The crossing of tracks at different levels gave rise to the great-

est complications here, as at Van Wyck avenue. Three Montauk division main tracks cross over two tracks leading to the Morris Park coach cleaning yard a short distance west of the street at such an angle that it was necessary for one of the wing walls of the underpass to extend over the arch. In order to carry this wall across the arch without placing its weight on the crown, thereby introducing eccentric loading, a special concrete beam was designed, the lower surface of which conformed roughly to the contour of the upper arch ring and which carried the load of the wall onto the haunches of the arch. This beam was built on the line of the wall on a skew of 75 deg. with the center of the arch, and is 53 ft. 3 in. long, this dimension in itself being unusual for a beam of this construction. The beam is 16 ft. 8 in. deep over the center of the arch and 25 ft. deep at the ends. It was very heavily reinforced horizontally along the base and the front face as well as vertically. The beam was designed with a chamber of 9 in. The interesting features of this unusual design are shown in the accompanying drawing.

Other streets at which openings under the tracks are maintained are Foley, Guilford, Rockaway road and Church streets. At Guilford street the design was complicated by details of the station, which will be referred to later.

**RETAINING WALLS.**

Including all work at the various street crossings, over 100,000 cu. yd. of concrete are required on the entire project. During the past few months between 4,000 and 5,000 yd. of concrete have been deposited monthly. A large amount of this goes into retaining walls along property lines, and between adjacent tracks at different elevations. In the design of these walls nothing un-

and cement are set. A narrow gage track leading to the mixer was laid alongside the standard gage track with a second narrow gage track connecting with it near the mixer and at a point beyond the material cars. Small steel cars are loaded on the narrow gage track alongside the material track, the stone, sand and cement being each placed in the car in turn, marks upon the sides of the cars denoting the proper quantities of each. In this way each car is loaded complete with materials for one batch of concrete. The grades on the narrow gage tracks are arranged to provide a down hill run to the mixer and, by a simple arrangement of cables, the loaded car descending pulls an empty one up on the other track. Arriving at the mixer the car dumps its contents into a hopper which is depressed sufficiently to receive the materials by gravity. After mixing the concrete is dumped by gravity into another hopper still lower, which is then elevated in a tower and dumped into a third hopper somewhat above the level of the work. Concrete is released from this hopper by gravity into carts and trucked down grade to the place of deposit. As this hopper has a storage capacity of several batches, practically continuous depositing can be maintained. With this arrangement a relatively small amount of labor is required. With such a plant it has been found possible to mix 200 yd. of concrete daily with a 1/2 yd. mixer.

Over 1,500,000 cu. yds. of filling material is required for the entire project, of which about 1,200,000 cu. yds. is now in place. This material is brought in in 12 yds. Western air dump cars from Cold Spring, about 25 miles east of Jamaica, where some heavy grade revision and realignment work is in progress. In each instance the first track has been gradually raised to grade by filling underneath it, and trestles have not been resorted to.

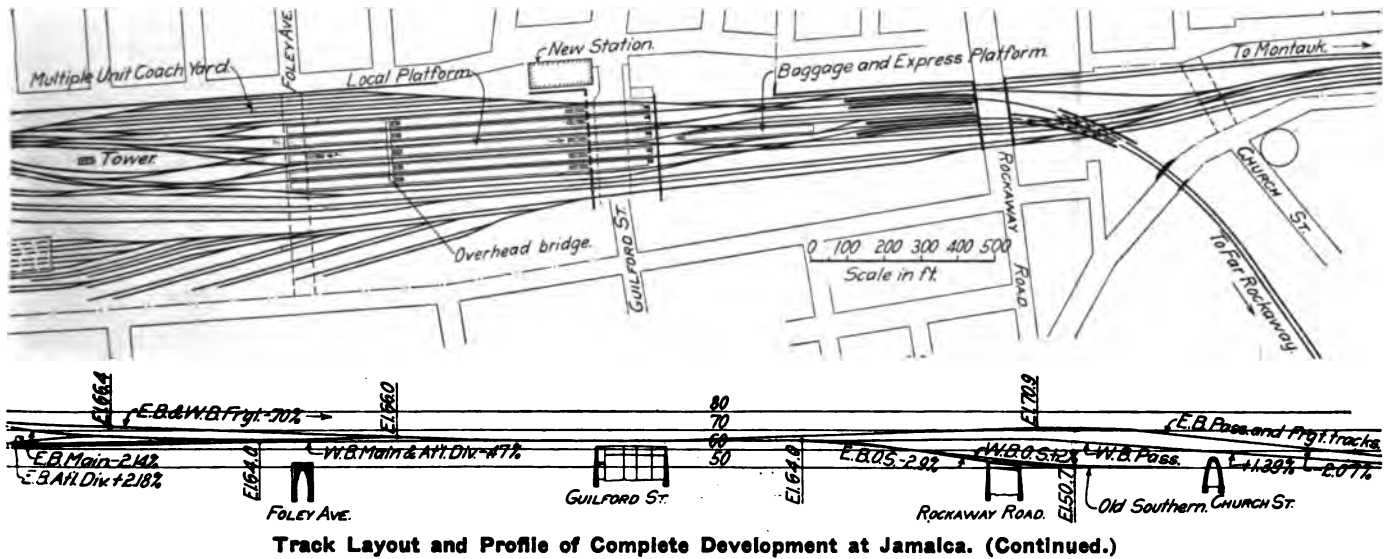

**Track Layout and Profile of Complete Development at Jamaica. (Continued.)**

usual has been brought out, as they follow general standards except that in a number of instances walls are built between high and low level tracks resting on the fill and anticipating some settlement. It would otherwise have been necessary to carry the footing down through this filling to a solid foundation beneath. It was deemed advisable to anticipate some settlement and make provision for it, and while such settlement has occurred in some instances, there have been no serious effects and the cost of these walls has been greatly reduced. One interesting detail has been developed in their construction. In several instances where a considerable length of wall of a uniform section was required, rails were laid on the footings and the forms were mounted on small trucks. After the completion of one section the forms were then rolled to the next section without dismantling them, saving considerable time and expense.

Careful attention was also given to the arrangement of the concrete mixing plant, and after several trials the following was adopted as the most economical. A standard gage track was laid as near the mixer as practicable, on which cars with stone, sand

After the first track has been brought to grade the embankment is widened by unloading from it. Where differences in grade exist between adjacent main tracks the slopes are sodded and concrete drains provided to eliminate erosion.

**PASSENGER STATION AND OFFICE BUILDING.**

In connection with these improvements it was necessary to provide a new station and plans were made for one costing \$235,000, which is now practically complete. The old station was a small frame building located east of Church street on the ground level. As the Old Southern branch left the main line west of this point a separate station was required for this branch and reverse movements were sometimes made into the main station. In planning for the new station a new location west of this junction was essential to serve all branches and a site was selected just west of Guilford street with platforms extending to Foley street. The station building is located on the street level north of the tracks and is five stories high, although the steel work is designed for an ultimate height of 12 stories. The building is

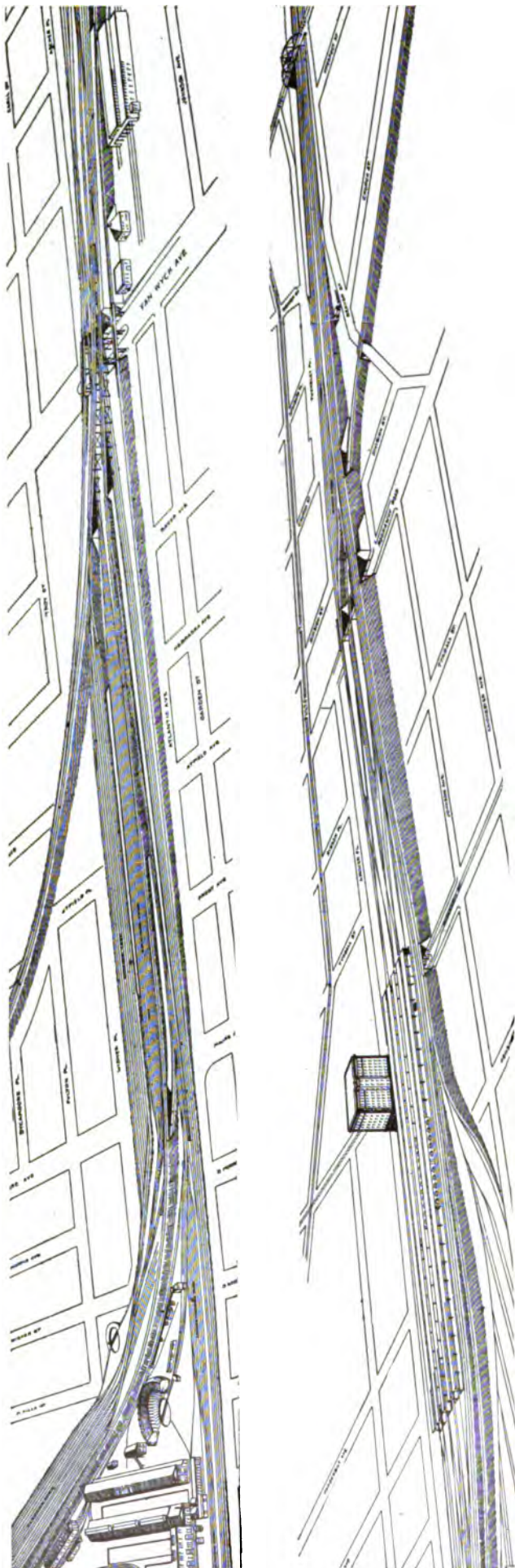

Perspective View of Long Island Improvements at Jamaica.

of steel construction faced with buff terra cotta for the two lower floors and with brick above that. The station facilities utilize the east half of the two lower floors with the usual arrangement



View from High Level Tracks East of Van Wyck Avenue, Looking West.

of ticket offices, check and waiting rooms. The remainder of the building is occupied with the general offices of the road other than the executive offices, which will remain in the Pennsyl-

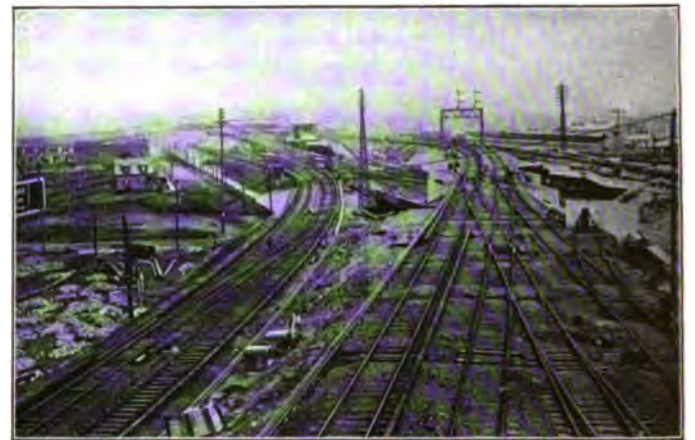

View from High Level Tracks West of Van Wyck Avenue, Looking Southeast.

vania Terminal, New York. The waiting room is finished in tile with green trimmings up to a height of 10 ft., above which is a buff mat surface. All openings are trimmed with marble.



View from Top of Shelter Shed at the West End of Platform, Looking West.

Entrance to the platforms is gained by a mezzanine floor connecting with the south end of the waiting room, with stairways to the different platforms, this mezzanine floor being directly

over the street sidewalk along the west side of Guilford street. With the exception of an entrance to the local platform from Foley street at the west end, this mezzanine floor affords the only approach to the platforms. Tandem stairways which separate inbound and outbound traffic lead to the various platforms. Five platforms are provided, each 1,000 ft. long and 22 ft. wide, serving eight tracks in all. These platforms are covered with umbrella sheds of steel construction with timber roofs covered



View Looking East from East End of Station Platforms, Showing High Retaining Wall on Left.

with tar and gravel. The roof is sloped from the center and outer edges towards the posts, with drains leading down the posts to sewers below the platforms. The steel columns are of built-up I-beam sections and with the down spouts are encased in concrete. Two enclosed shelters are provided on each of the platforms and an overhead bridge is built near the west end to enable passengers to transfer from one platform to another.

As the platforms are built on a fill averaging over 20 ft. in



Van Wyck Avenue Bridge, from Roadway, Looking North.

height it is necessary to support them on piles. For this purpose about 600 28-ft. concrete piles, 16 in. in diameter were required.



North Portal of Maure Avenue Arch, Looking South.

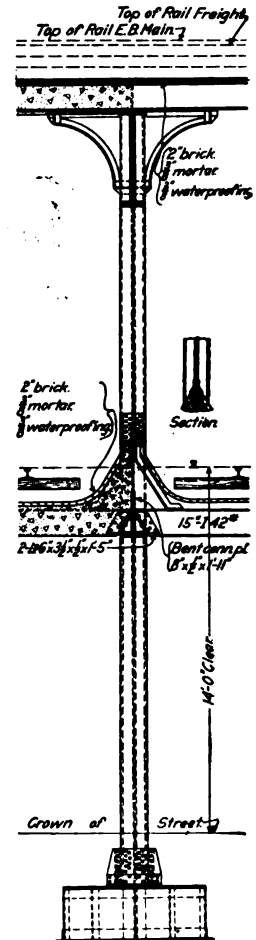
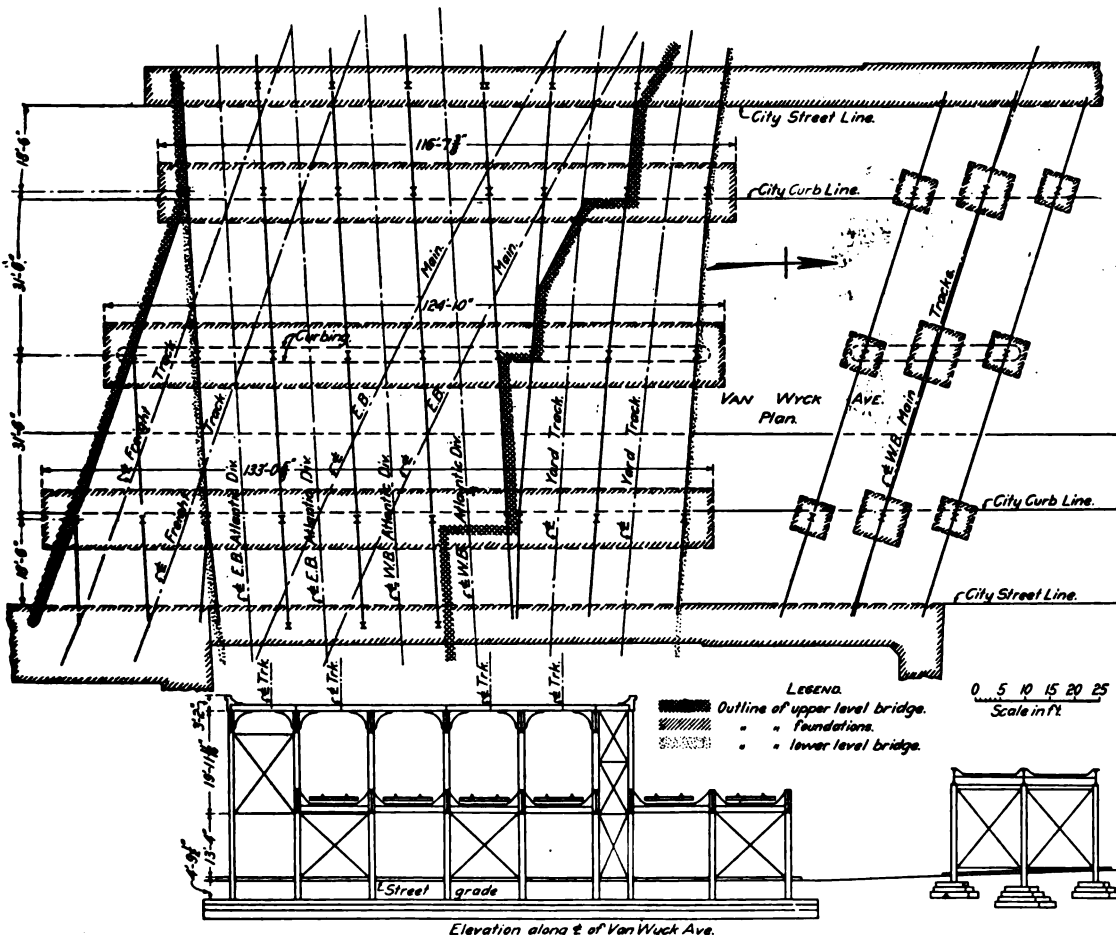

At first these piles were bought in the market, but as it was found that they could be made cheaper on the work most of them were made by company forces. They are reinforced with eight rods running lengthwise through the pile and with spiral banding spaced closely at the top and bottom and spread to a maximum of 12 in. at the center. These piles were cast in a horizontal position and after 24 hours the forms other than the

driveway for express wagons are located under the tracks, the viaduct being lengthened an additional 61 ft. beyond the street line to provide for these facilities. Five elevators are provided to raise baggage and express to the track level. Business re-

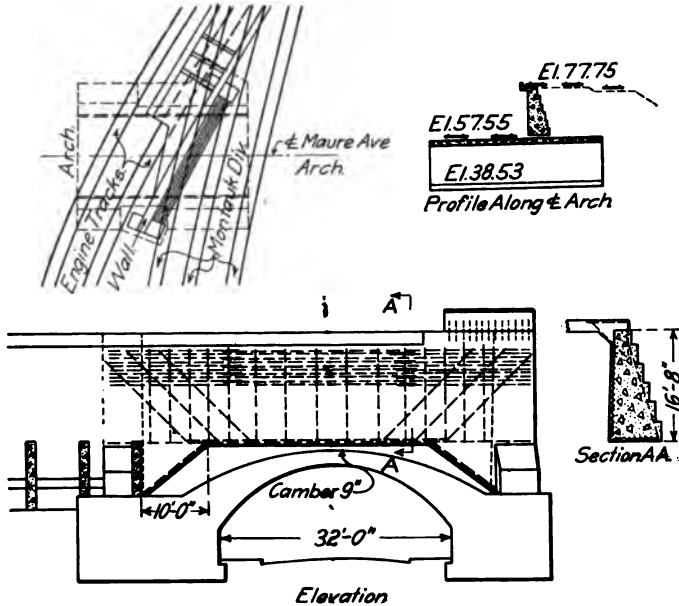

Plan and Elevation of Special Retaining Wall at Maure Avenue.

bottom boards were removed. After seasoning for two weeks in this position they were stacked up. No piles were driven until after they had been seasoned at least one month. A gang of 20 men was able to make 10 of these piles in a day, and careful figures show that their cost was reduced to about \$.50 per lin. ft. Two rows of piles were driven under each platform, the rows being spaced 12 ft. center to center, while the piles in each row



Looking Down on the Wing Wall of the Underjump at Maure Avenue.

are spaced 15 ft. between centers. These piles were capped by beams running parallel to and across the platform supporting the concrete floor. The outer edge of the platform is sloped upward slightly for a distance of 2 ft. to prevent passengers from slipping toward the edge. The surface was marked in 2 ft. squares and indented with a spiked roller to provide sure footing and to facilitate the escape of water.

On the east side of Guilford street the express office and a



Maure Avenue Underjump Under Construction, Looking West.

quiring transfer from one track to another is lowered to the street level by one elevator and hoisted by another, but provision is made for handling baggage at the track grade in case of emergency.

YARDS.

The extensive rearrangement of tracks required the construction of new yards for storing and cleaning the various types of

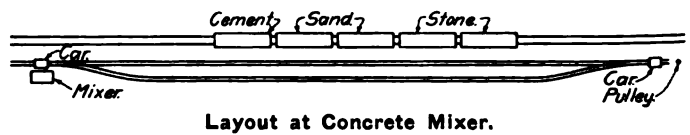

Layout at Concrete Mixer.

equipment, and with the exception of the locomotive terminal, which is left undisturbed at the lower level between the Atlantic and Montauk divisions, two miles west of the station, all the yards at Jamaica were rebuilt. A new 16-track coach cleaning yard for steam passenger equipment with a capacity of 132 cars



Station Building from Track Level, Looking Northeast.

was built on the elevation of the Montauk division opposite the roundhouse. These facilities are complete in themselves with a hollow tile and stucco frame service building, brick boiler house and conduits for air, water and steam pipes.

North of the Atlantic division tracks between Maure and Van Wyck avenues are two coach yards, the northerly or westbound one having eight tracks with a total capacity of 86 cars, and the eastbound one, seven tracks with a capacity of 97 cars. The grades of each are so arranged as to be favorable to movements in the advance direction. A third coach yard for the use of multiple unit equipment is provided north of the west end of the station platform. This yard is on the level of the adjacent main lines and consists of five tracks with a capacity of 56 cars. Directly across the main lines from this are a seven track team track yard, freight house and an inspection and repair shop



Station Building, Platforms and Shelters, Looking West.

for the multiple unit equipment. All of these latter facilities are on the ground level and are reached by a track ascending to a connection with the main freight tracks near Rockaway road.

No. 10 simple or slip switches are generally used in the main tracks, slip switches being used freely in the vicinity of the station because of the limited space available and the wide variety of movements to be provided for. Switches in the vicinity of the station will be controlled by electro-pneumatic interlocking plants. One large tower midway between Foley and Van Wyck avenues will control all switches between the west end of the station and a short distance west of Van Wyck avenue, while a second tower will be placed a short distance east of Guilford street to govern movements at the east end of the station and the connections with the Old Southern branch.

One of the most difficult conditions to contend with in the

vicinity of Rockaway road east of the station during the past winter. By removing those tracks in the center of the right of way to the south side and shifting the Old Southern branch connection a short distance west of its permanent location, it was possible to complete those portions of the structures shown solid without interference to the other tracks. Upon the completion of this work the main line tracks were shifted on it and the balance of the concrete work shown hatched was then put in. The tracks could not be shifted to the south until after the summer rush was over, so that it was impossible to start concreting until about October 10. It was then necessary to complete those portions of the work shown solid by February 1 in order that the portion shown hatched could be completed in time to enable the tracks to be placed on their permanent location before the summer traffic began in the early part of June.

This work has been under construction for the past two years and is now practically completed. It has all been handled under the direction of J. L. Savage, chief engineer of the Long Island Railroad; L. B. Morris, chief engineer of Jamaica improvements, and F. Auryansen, bridge engineer. All construction work has been done by company forces under the personal direction of Mr. Savage.

### NEW ENGINE TERMINALS ON THE WESTERN MARYLAND.

By GUSTAVE E. LEMMERICH.

The Western Maryland has about completed new engine terminals at Hagerstown, Md., and Maryland Junction, W. Va. These terminals are practically of the same layout and design, but more room was available at Maryland Junction than at Hagerstown. One of the illustrations shows the arrangement of tracks and buildings at Maryland Junction. This terminal is between two division yards and is laid out so that locomotives from each of the yards can enter at the same time. There are two incoming and two outgoing tracks with engine storage tracks. The incoming tracks have inspection and ash pits and coal can be taken on four tracks; the coaling station is of the Holman type, built by Roberts & Schaeffer. Locomotives which do not re-

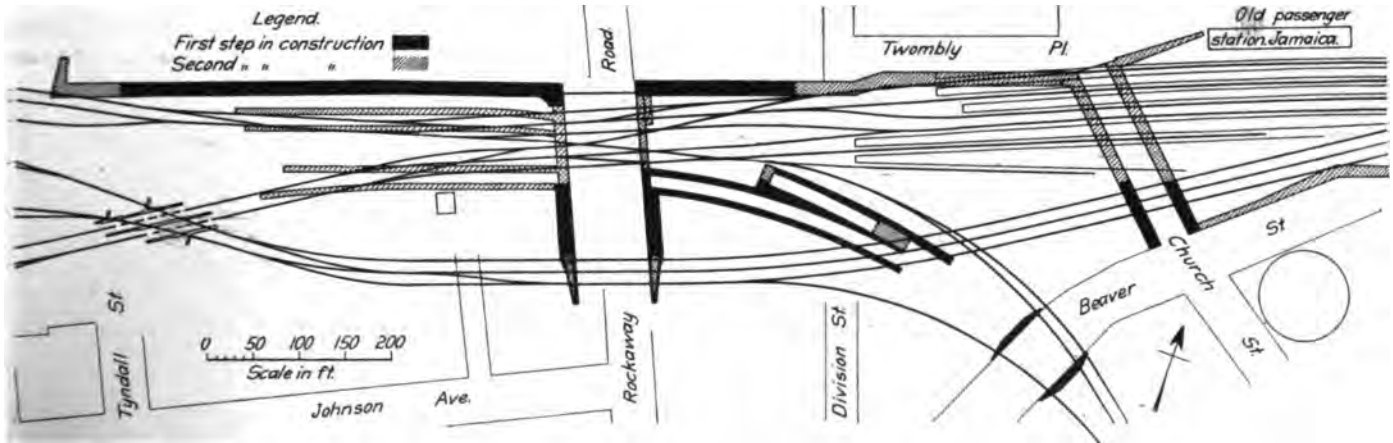

Temporary Track Layout for First Stage of Construction Work East of New Station.

prosecution of this work has been the maintenance of traffic at all times. Because of the greatly increased passenger traffic during the summer months this has necessitated the almost entire abandonment of work involving interference with the main lines at this season, requiring the prosecution of such work largely during the winter. This has required the working out of a very careful schedule of operations in advance so that all work tending to interfere with main line operation can be completed before June 1. A good example of this is shown in one of the accompanying drawings illustrating the schedule of oper-

quire to be turned or to go to the engine house, can pass over the crossover to the engine storage tracks.

A 100 ft. turntable is provided, which permits the placing of a switch engine and a car on the table at the same time. If the table is installed before the engine house is started a considerable saving is effected in the delivery of material for the construction of the house, and also in time, so that a 100 ft. table is about equal in cost to an 80 ft. one.

The engine house is of 105 ft. wide and is constructed with a steel frame; the outer walls are of brick, with almost all the

space above the window sills occupied by windows. It is heated by hot air through underground ducts, with outlets in the pits and rear walls. The heating system is of liberal proportions, the apparatus being furnished by the Buffalo Forge Company, and a boiler washing system is also installed. The engine house is provided with a 10-ton electric traveling crane.

also extend outside the building. Through these lines of cranes material can be transferred to and from all parts of the shops, storehouse, roundhouse, outside tracks, etc.

The layout and designs were made by the writer under the supervision of H. R. Platt, chief engineer of the Western Maryland. G. E. Painter, Baltimore, was consulting me-

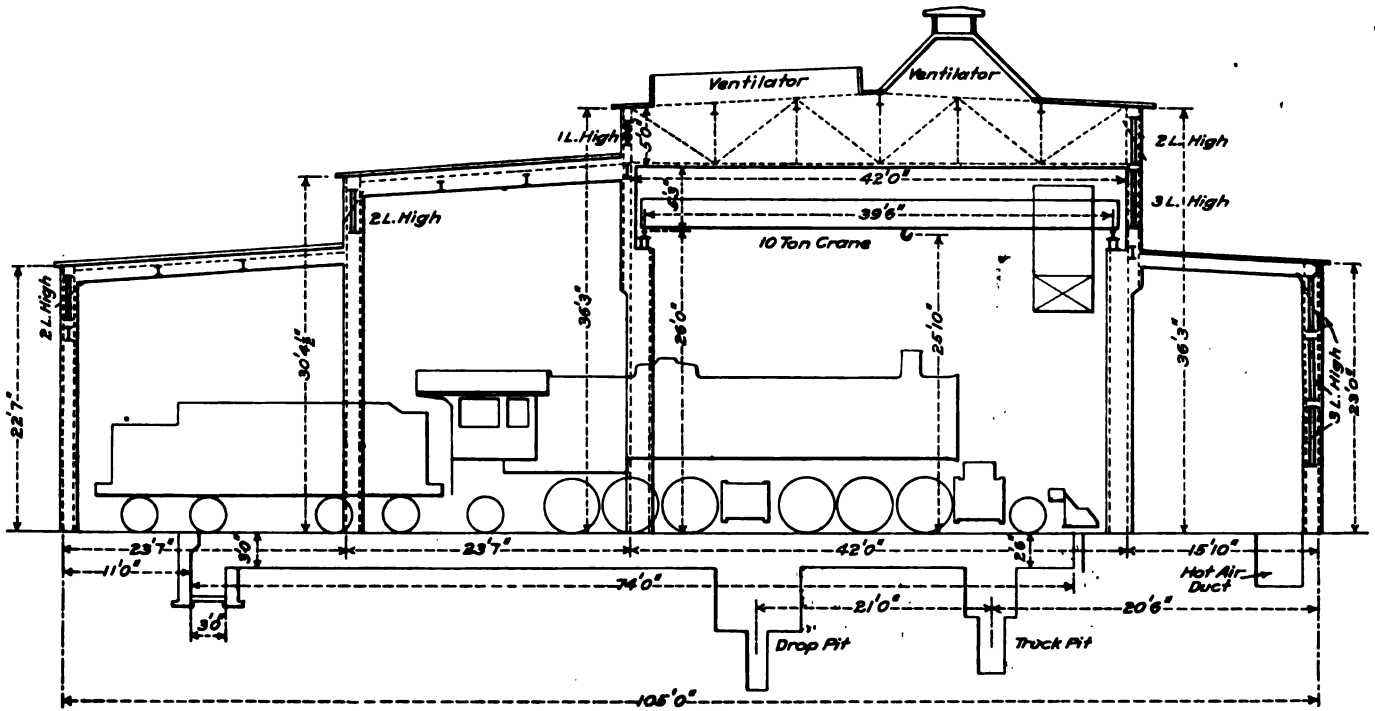

Cross Section Through Western Maryland Engine House, Showing Travelling Crane.

The Western Maryland has had shop facilities of very limited proportions, and on this account these engine terminals had to be equipped on a more liberal scale to tide the motive power department over until proper general repair shops can be developed. All the shop buildings are of a steel frame construction with brick curtain walls and plenty of glass area.

At Maryland Junction the ground next to the engine terminal is intended to be used for a general freight car repair shop

mechanical engineer under the supervision of C. R. Tritsch, superintendent motive power and car department of the Western Maryland.

LOCOMOTIVES NEEDED IN NEW SOUTH WALES.—Owing to the shortage of tractive power and the inability of the state to undertake the work of building without serious delay in providing additional workshop plant and facilities, the chief railway

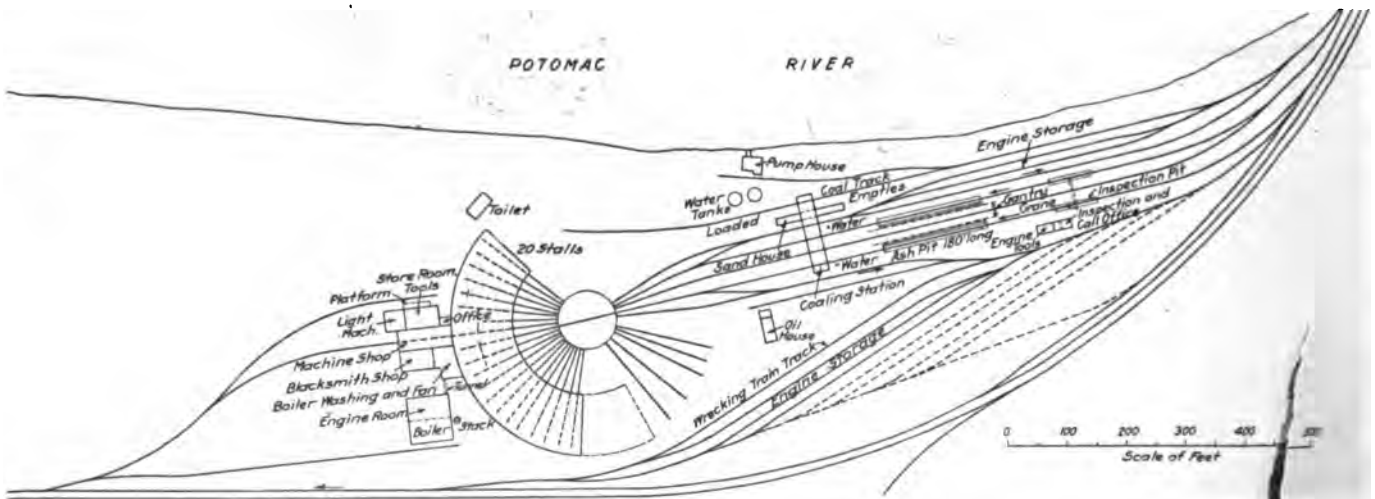

Locomotive Terminal of the Western Maryland at Maryland Junction, Va.

and the machine shop is therefore laid out to be extended to serve this repair shop also. Provision is made for a future traveling crane in the machine shop running from the roundhouse to the outside of the extension; another crane will run at right angles on a midway, connecting the future storehouse, mill, etc., with the freight car shop. Cranes in this shop will

commissioner of New South Wales has made an urgent requisition upon the government for the importation of 80 locomotives. The order, which represents about \$400,000, caused some consternation among the ministers who are in favor of supporting local industries. The matter was deferred pending further information.

# DEVELOPMENT OF THE EAST INDIAN RAILWAY.

The Pennsylvania of Asia Has a Mileage of 2,500—Main Trunk Line 1,020 Miles Long Built Nearly 50 Years Ago.

BY LEWIS R. FREEMAN.

"An American railway man would probably be able to learn little in India that would be of practical use to him in his own work," a Calcutta railway official said to me a short time ago; "but, in the problems which we have solved and have still to solve, he ought to find a great deal to interest him."

India, in the past, has brought her railway ideas as she has her railway materials, from England, and there is little of either

conservative London boards and the comparative inefficiency of the native employees, rather than on account of a lack of belief in and enthusiasm for the methods themselves.

The one great thing which Indian railways accomplish better than our own is the safe carrying of passengers. Out of 371,580,000 passengers carried by the Indian railways in 1910, but three were killed from causes beyond their own control. This remarkable showing is due to the fact that the great majority of passengers is willing to travel at a low rate of speed, to the insistence of the government on the provision of adequate safeguards at stations and crossings and to the adherence to a certain very high standard of construction. The American public insists on speed at any cost, even if that cost is paid in lives; and, in comparison with their respective revenues, there is not nearly so high an average cost of construction in America as in India. Although the latter country has nothing to approach the roadbeds of the trunk lines of the New York Central, the Pennsylvania and one or two other roads in the eastern section of America, it never had anything to parallel those early western roads, with their wooden trestles, unballasted tracks and ramshackle stations.

Ask any Indian railway man to name what he considers the most "desirable property" among the lines of that empire and, after possibly a few words about the fine showing of his own line, there is sure to be some reference to the East Indian Railway. This road illustrates what is best in, and typical of, the railroads in India. It was built soon after 1850 by a company formed in co-operation with the Honorable East India

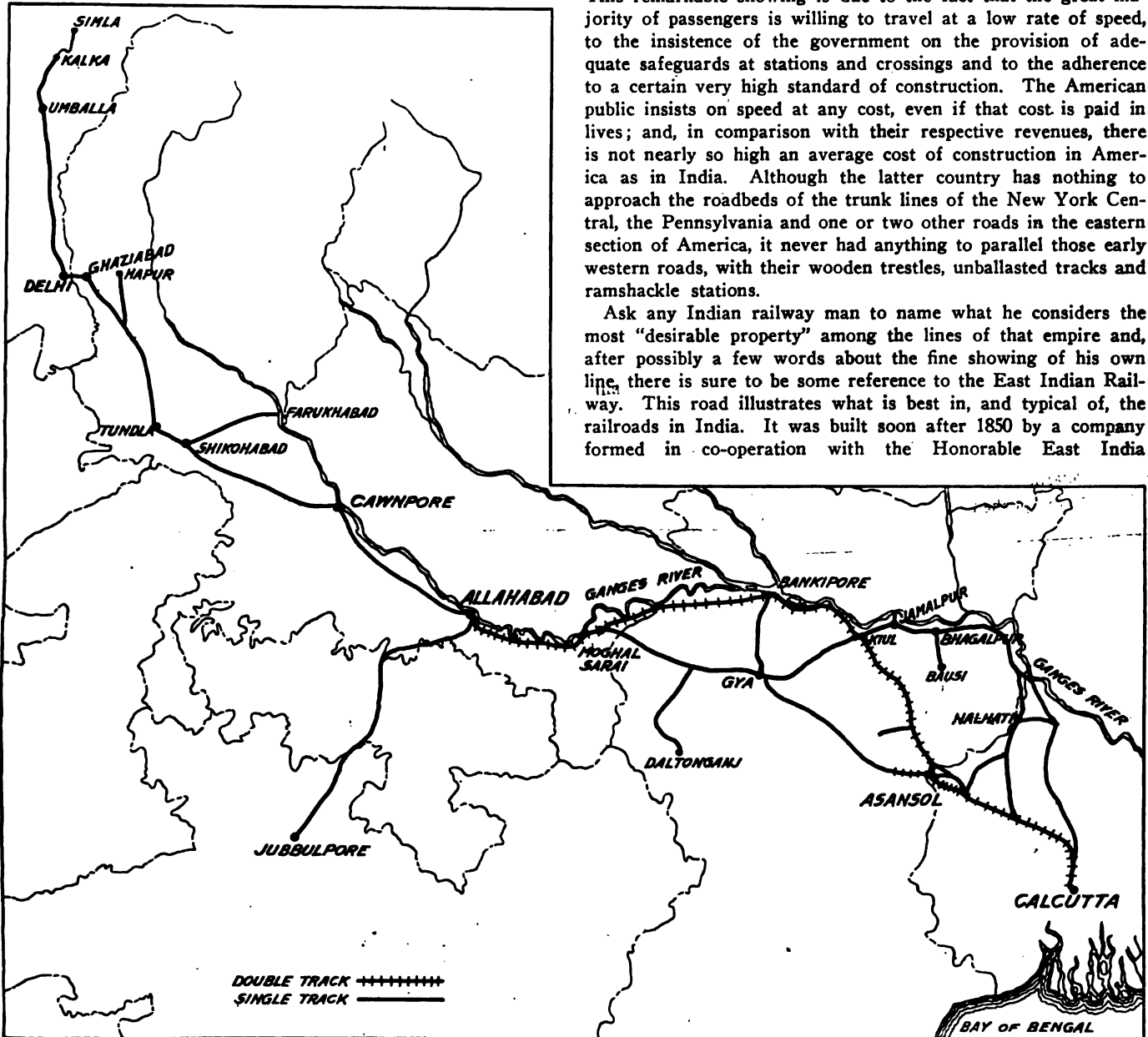

The East Indian Railway.

that America, in its present stage of railway development, could find use for. India still buys her materials in England, but for ideas she is beginning to look to America rather than the old country. Nearly every Indian railway man who has the time, tries to arrange his home leave so as to visit the United States—and one finds among those who have done so a familiarity with modern American railway methods which are rarely put in practice in India on account of the opposition of the ultra-

Company, which at that time controlled the destinies of India. Being the pioneer line in the richest part of India, the great prize of the territory of the Plains of the Ganges fell to its lot by priority of occupancy, a circumstance to which is largely traceable the pre-eminent position which the road occupies today.

To read the history of the East Indian Railway—and a very interesting record has been written by G. Huddleston, C. I. E.,



who was for many years chief superintendent of that line, and who is now at the head of the Burma Railways—is to read a large part of the history of modern India. Projected in 1845, and with the first section open for traffic in 1853, it shared with the telegraph the honor of saving India in the Sepoy rebellion of 1857. Without the hundred odd miles of line already completed when the trouble broke out it is probable that the mutiny might have taken years to suppress; with the line completed to

with renewed energy. Great difficulty was experienced in transporting materials to the intermediate centers of construction, while for a time a serious outbreak of cholera threatened to put a stop to the work altogether. For some months no less than 10 per cent. of the coolies employed died weekly, and during the epidemic it is estimated that no less than 4,000 laborers succumbed. By the end of 1861 the company had open 359 miles of line in Bengal and 243 miles in the northwest provinces, a



Coal Train on a Double-Track Stretch.

Delhi, or even to Cawnpore, the whole dreadful affair might have been checked before it had time to spread. A large number of the company's engineers were killed in the Cawnpore massacre, and two others especially distinguished themselves in the gallant defense of Arrah.

Construction was considerably retarded during the early days of the mutiny, but in 1858-9 work was pushed at several points

total of over 600 miles. This gave an average of 60 miles a year for the ten years during which the line had been under construction, "a record which," in the words of the viceroy of that period, "while not up to expectations first entertained, is satisfactory as regards the past and encouraging as regards the future."

At the outset the most encouraging thing was the attitude of

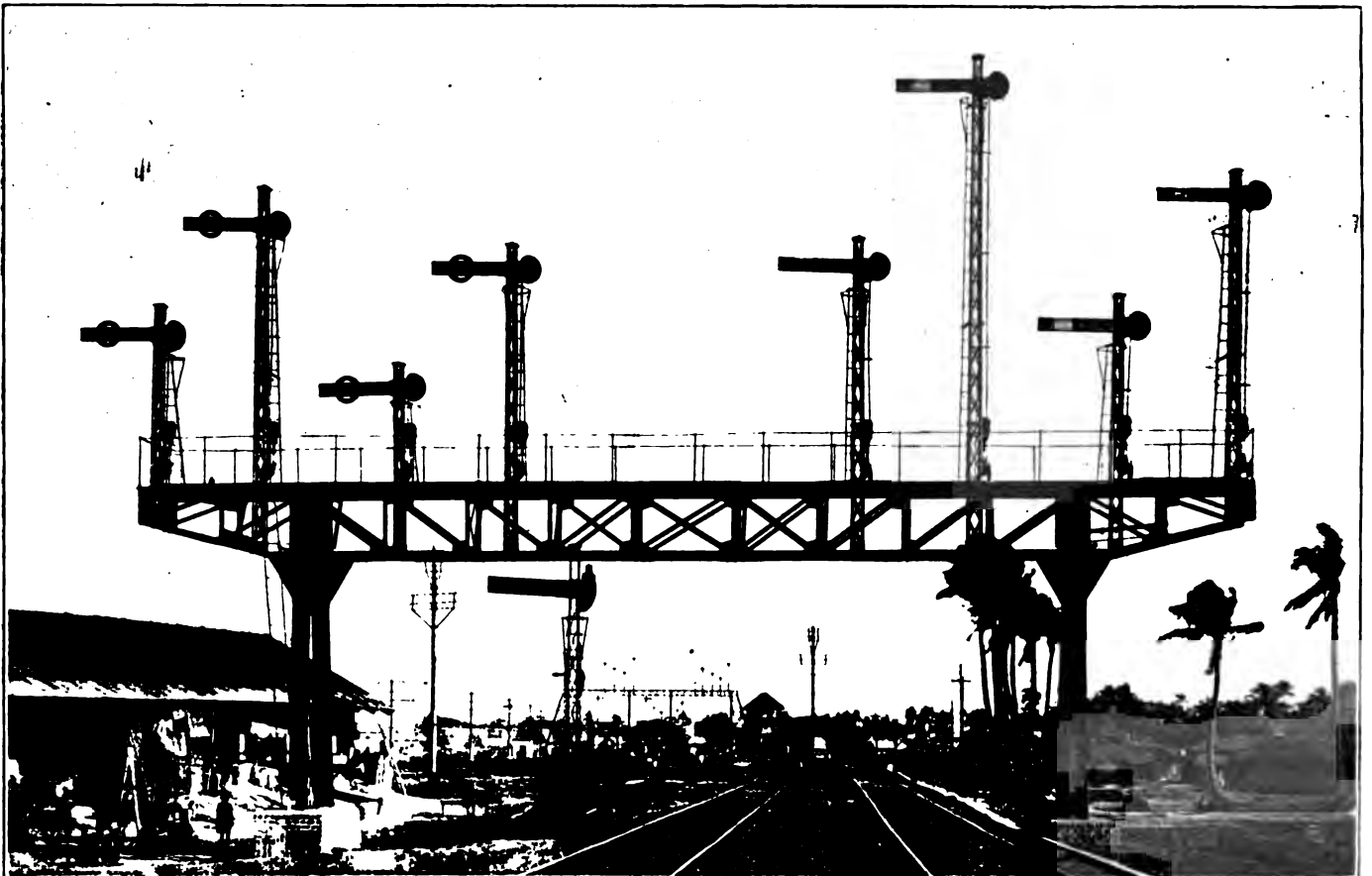

Semaphores at the Allahabad Yards.

the natives toward the railroad. Not only did they prove willing to come forward as laborers in satisfactory numbers, but they also displayed an amazing readiness to patronize the completed line. The figures for the first five years' business of the East Indian were prophetic not only of the success of that line, but of all the lines which were projected in a dozen widely separated sections of the empire.

In 1864, save for the break at the ferry where the Jumna bridge at Allahabad was still unfinished, passengers could travel by rail the whole 1,020 miles from Calcutta to Delhi. The latter point is the terminus of the E. I. R. proper today; so it may be said that the main trunk of the system was completed nearly fifty years ago, a long time before transcontinental communication was established in the United States. The chairman of the board, speaking in London at that time, pointed out that no line, either in England or on the continent of Europe, could compare with the main line of the E. I. R. in "magnitude or continuous length; nor could the Grand Trunk line of Can-

through a large number of populous cities in its East Indian section, and it is this, doubtless, that is responsible for the fact that, in spite of the opening of a much more direct route via Nagpur, it still remains the main line of communication between Calcutta and Bombay.

Consideration of population centers was also responsible for carrying the original line of the E. I. R. a long ways to the north of what would have been the most direct route to Delhi and the Punjab. The first section of the railway was planned to tap the Ganges at Rajmahal, but by the time construction was completed to that point the Holy river, with characteristic capriciousness, had changed its course and the importance of Rajmahal was a thing of the past. Had the plan of building in as direct a line as possible to Benares been followed it would not only have given a much shorter route to the northwest provinces, but would also have led to the discovery and exploitation of the great Jherriah coal fields forty years earlier than they were actually opened up, besides altering completely



Interior of the E. I. R. Station at Calcutta, the Largest Station in India.

ada compare with it as to works, progress or length of line." I have no figures as to the progress of railroads in the United States, but I should be surprised to learn that any one company had very much over 1,000 miles of continuous line in operation at the end of the Civil War.

It had been the original intention to permit the E. I. R. to extend on to Lahore and the frontier, but special considerations, principally strategic, prompted the government to build that line itself. It has since developed into the great 5,000-mile Northwestern Railway system, still owned and operated by the state. In this territory the E. I. R. operates, but does not own, the 162 miles of 5 ft. 6 in. gage line of the Delhi-Umballa-Kalka railway which was opened in 1891 to handle the Simla traffic.

The next important event in the history of the construction of the E. I. R. was the completion of the 242 mile branch from Naini Junction, near Allahabad, to Jubbulpore, where connection with the Great Indian Peninsula Railway formed the first trans-Indian line. This route, though extremely circuitous, passed

the whole complexion of the Indian mutiny in making Benares instead of Calcutta the base of British operations. The original line still exists for local traffic, but the construction of two chords or "cut-offs" have successively reduced the distance to the northwest. Delhi, distant from Howrah (Calcutta) 903 miles by the main line, is reached in 29 hours from the latter point by the Punjab Mail, the fastest of the through trains.

The E. I. R. has been closely confined to the sphere which it occupied at the time of the completion of its main line to Delhi in 1864, and since that year its efforts have been largely directed to net-working this territory with branches, improving the existing lines and stimulating traffic. How well the latter has been done may be gathered from the following figures: In 1911 the number of passengers carried by the E. I. R. was 36,844,000, and the average journey was 58 miles. In the same year 8,508,000 tons of coal and 6,533,000 tons of merchandise were moved and the average merchandise haul was 248 miles.

The total mileage of the E. I. R. is just under 2,500, of which

about 600 are double track and 15 triple. The gage is 5 ft. 6 in. The Delhi-Umballa-Kalka and other lines operated bring the total mileage under E. I. R. management up to 2,800. The construction cost was about \$88,300 per mile. To appreciate what good construction this means one should consider that the whole line lies in a flat country, where little cutting or filling was necessary, and that it was built by the cheapest labor offered by any country in the world, not excepting China. Eighty-eight thousand dollars goes a long way under these conditions, and in the case of the E. I. R. it has found its way into a substantial roadbed, fireproof stations, well built rolling stock, and ample safety devices. The main line from Calcutta to Delhi is laid with steel rails, those on the eastern end being 85 and 88½ lb. rail. The rest of the main line and branches are laid with 75 lb. rails. A few short branches are still laid with iron rails, but these are being replaced with second-hand steel rails removed from the main line in the course of relaying operations. About 30 per cent. of the ties are wood and the remainder are iron. The wooden ties consist principally of sal and deodar; but of late jarrah and Australian hardwood ties have also been put into the road. Sal is the best of the Indian woods for ties, but, even to roads running through jungles in which the tree is found, it is sold for upwards of \$1.25 a tie. This seems a high price considering the cheapness of labor in India, but it is probably due to the fact that the trees are widely scattered. Australian sleepers for the unusually broad Indian gage will probably cost a little less than \$2 apiece. The iron sleepers are of the Denham-Olpherts pattern and weigh about 252 lbs. each. The line is stone ballasted and fenced throughout and the sharpest curve is of 1,000 ft. radius. On the main line the ruling grade is 0.3 per cent., with a 1 per cent. grade on the section between Simultala and Jhajha. On the grand chord the ruling grade is 0.5 per



Dining Car Interior.

cent., compensated on curves, with a 1.25 per cent. grade on the section between Gurja and Gujhandi. The branches have a ruling grade of 0.5 per cent.

By the agreement with the East India Company certain conditions under which the line might ultimately be purchased by the former were laid down. These rights the Indian government, which had succeeded to them on taking over the affairs of the chartered company after the Indian mutiny, decided to exercise in 1876. The negotiations covered several years, and it was not until January 1, 1880, that the deal was completed. At this time all the contracts then existing between the secretary of state and the company were determined. The purchase price was \$163,750,000, which sum was arrived at by adding the stipu-

lated 25 per cent. premium to the market value of the company's stock at date of purchase. It was provided by the purchase act that this should be paid in the form of a terminable annuity of \$7,368,750, payable from date of purchase to 1953. One-fifth of the annuity was deferred, and the holders of this portion (representing a capital of \$32,750,000), constitute the present East Indian Railway Company, which, since the date of purchase, has operated the railway for the government. The deferred annuity holders receive, in lieu of the annuity, interest at 4 per cent. a year on \$32,750,000 and a share of the surplus profits of the railway. The terms of operation are as follows: After deducting from the gross earnings of the railway the operating expenses, the surplus profits up to a sum of \$833,000 are divided in proportion of four-fifths to the government and one-fifth to the company. Any excess over this sum is divided in proportion



Typical Culvert, E. I. R.

of fourteen-fifteenths to the government and one-fifteenth to the company.

As on other Indian railways, the E. I. R. is permitted to raise and lower fares and rates only between certain maxima and minima fixed by the government.

The location of the E. I. R. shops at Jamalpur, a couple of hundred miles from Calcutta and off the present main line, was an unfortunate result of an early change of plans. These shops had grown beyond a point which made it practicable to move them before the mistake was realized, and now, in spite of their inconvenient location, they have increased to an extent that has gained for Jamalpur the title of the "Crewe of India." The workshops cover an area of over a hundred acres, 20 of which are under roof, the whole being fenced with a high iron fence. On the score of sanitation, quarters, amusements, etc., the place is the model colony of India.

The shops are now in a position to build locomotives to meet all the requirements of the line. This work had been going on for some years, but owing to the heavy volume of repairs it was not until recently that extensions made it possible to give much attention to the building of new engines. Almost all the parts of a locomotive can now be made in the shops, including all-steel castings, and the cost of a locomotive built at Jamalpur is considerably less than one purchased and imported. The Jamalpur engines have given most satisfactory results.

As Mr. Huddleston remarks in his valuable history of the E. I. R., there are larger railway shops existing in Europe than those at Jamalpur, but few are more self-contained or better equipped with modern electrically-driven machinery. The distance from England and the cost of freight and the accompanying delays in complying with indents for materials, etc., have been successfully overcome by the liberal and progressive policy the company has adopted in developing Jamalpur. In addition to actual locomotive work the shops undertake work for the engineering, stores, collieries and passenger car and freight car departments, and the whole of the manufacture of the Denham-Olpherts cast-iron tie, which is the standard in use on the line. All signaling and interlocking gear, posts, frames, etc., are made complete. It may be said that any general engineering work can be carried out in the shops as occasion demands.

The question of labor supply has become a troublesome one at Jamalpur, on account of the growth of the shops. It has, therefore, been necessary for some time to bring in labor daily, from a distance of 19 miles in one direction, seven in another, and six in another. Workmen's trains are run out to these places morning and evening to bring in and take back the men.

The shop plant includes a steel foundry, iron foundry, rolling mill, erecting and fitting shop, machine shops, point crossing and signal and interlocking, forge, smith, pattern, bolt and nut, brass finishing, tin and coppersmith's, cold saw, chain testing, wheel, boiler, millwright, paint and tender, and a modern and complete power house.

**AUTOMATIC TRAIN PIPE CONNECTOR.**

The Queen & Crescent has equipped its Blue Grass Special with the Durbin automatic train pipe connectors, which automatically couple the air, steam and signal lines, and also provide

for telephone communication between all of the cars and the locomotive. The connector is attached to the car independent of the coupler. It is of the butt-face type and all the connections are arranged in a vertical line coincident with the center line of the car. With the butt-faced coupler the ports will register



**Durbin Automatic Train Pipe Connector as Connected in Service.**

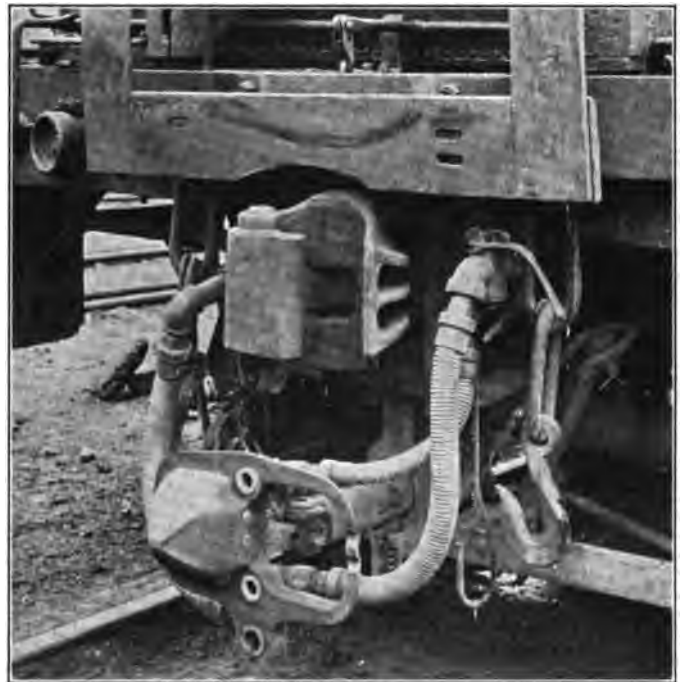

**Durbin Automatic Train Pipe Connector Applied to a Locomotive Tender.**

accurately when coupling, and the gaskets will not be subjected to such severe treatment as in the side-faced type; it is also possible to keep a more perfect joint between the gaskets without relying on springs to keep the heads together. The gaskets can also be replaced without separating the cars. Having the con-

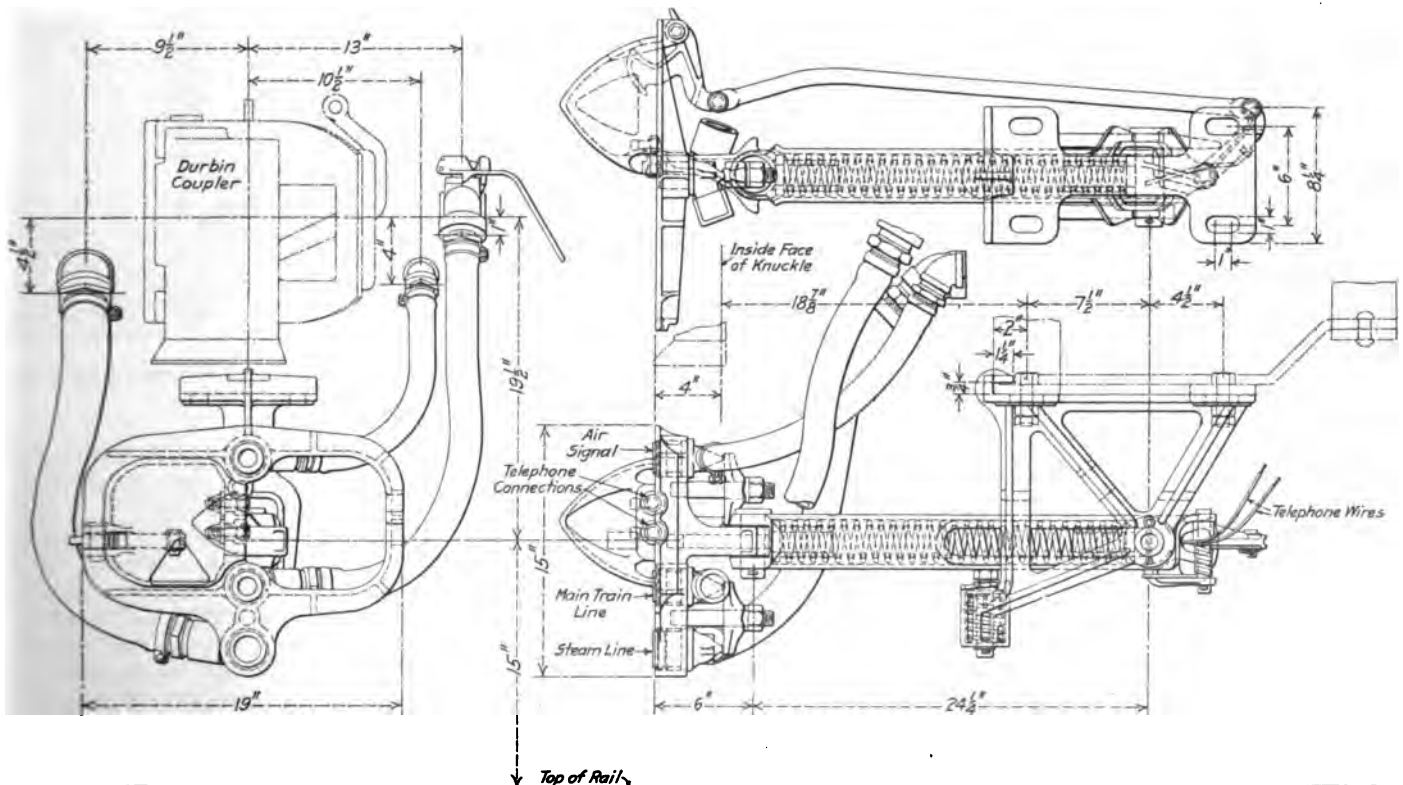

**Durbin Automatic Train Pipe Connector for the Queen & Crescent.**

nections in a vertical line has been found to be an improvement over having them in a horizontal line, for there is less liability of the connections springing apart and creating a leak when the train is passing around a curve.

The design of the connector is clearly shown in the illustrations. It is made of malleable iron and is pivoted 6 in. behind the face of the connector to allow for the curvature of the track. It is free to move 30 deg. each side of the center, and has a vertical travel of 10 in., which is sufficient to allow for uneven track. The coupler has a gathering range of 4½ in. in a vertical direction and 5 in. in a horizontal direction, which insures its engagement on any curve. It has a horizontal travel of 10 in., and is forced out by a spring made of vanadium steel. Even though the connectors are forced together by these springs when the cars are coupled, they also are automatically locked so that there is no possibility of their jarring open while on the road. This lock will only trip when the cars have been uncoupled and have started to separate. The hose couplings are held in the coupler head by a bridge bolt as shown in the drawing. This makes it possible for the hose coupling to be removed from the connector head for a new gasket without it being necessary to uncouple the cars. A metal gasket is used on the steam line. The plugs for the telephone connection are located between the signal line and air brake line couplings.

One of the greatest advantages of this connector is that it obviates the necessity of men going between the cars to couple the hose. It keeps the hose in an almost rigid position which will tend to reduce the hose failures due to abrasion, and on account of its construction it will practically eliminate torn hose. This device will also save considerable time in connecting up a train of cars. It is sold by the Durbin Automatic Train Pipe Connector Company, St. Louis, Mo.

### WELDING AND CUTTING WITH OXYGEN AND ILLUMINATING GAS.

The success that has attended the use of high temperature gases and electricity for the welding and cutting of metals has been so marked that any development of these systems will at once prove of interest. The system which is described in this article uses a combination of oxygen and illuminating gas taken from the city mains. One of the illustrations shows the apparatus

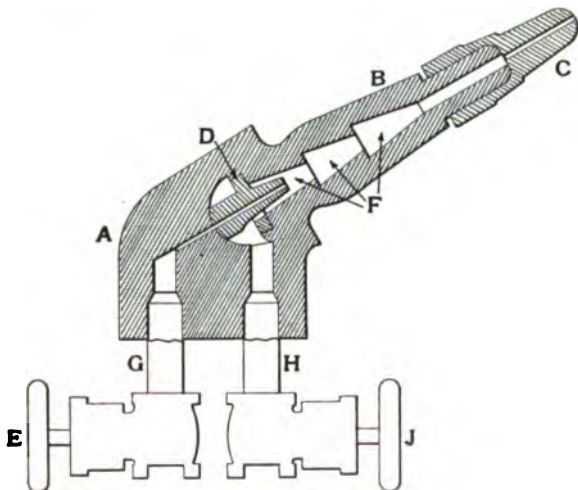

**Burner for Welding and Cutting with Oxygen and Illuminating Gas.**

as set up in a permanent installation, although, by the use of flexible connections a portable outfit may easily be constructed. The illuminating gas passes from the meters to a water jacketed booster *K* which is driven by a small electric motor; this booster is used to raise the pressure of the gas, its maximum capacity being 30 lbs. per sq. in., although more than 14 lbs.

is never required for even the heaviest cutting, as this pressure has proved sufficient when cutting steel bars 8 in. square. From the booster the gas passes upward through the pressure regulating waterseal *L*, then through the pipe *M* to the pressure gage and the specially constructed reducing valve *N*, which reduces the pressure to that required for whatever class of work is being done. From the reducing valve the gas passes directly through the pipe *O* to the burner where it is combined with the oxygen.

The use of tanked oxygen, as in other welding processes, is recommended. The oxygen is stored in the tanks *P* and passes through the small coiled pipe to the reducing valve *Q*, from which it passes through the pipe *R* to the burner. The maximum pressure used in the oxygen for welding is 25 lbs. per sq. in., and for heavy cutting up to 90 and 100 lbs. The illus-

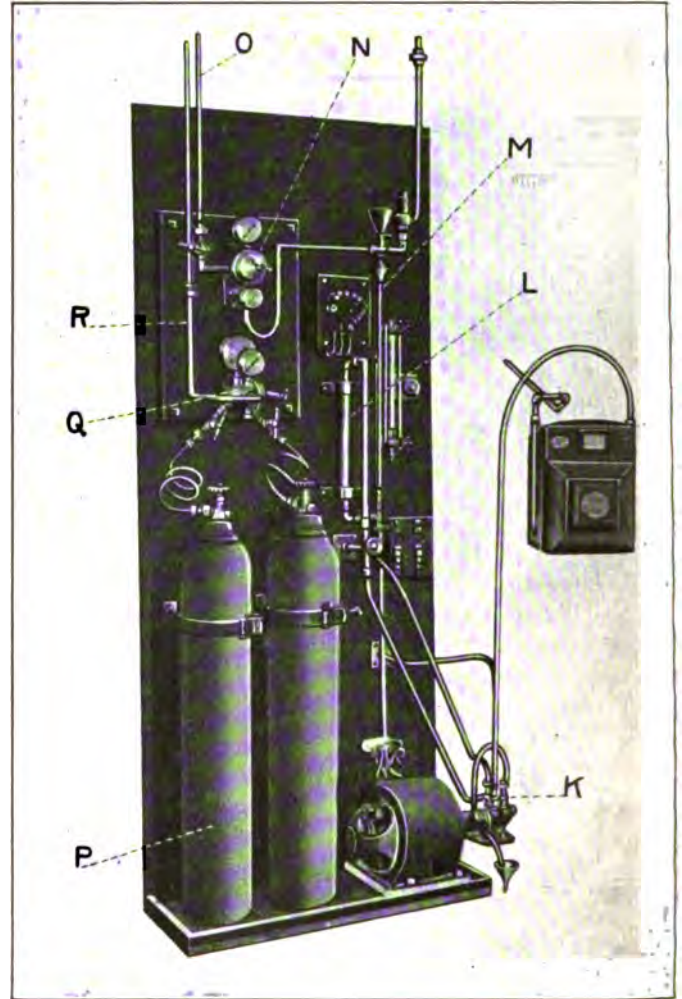

**Apparatus for Welding and Cutting with Oxygen and Illuminating Gas**

tration shows a two-torch outfit, but they may be built to any required size and there is one 14-torch outfit in successful operation.

The other illustration shows the construction of the burner or torch. This burner insures the complete mixture of the gases by means of the multiple stage system of mixing chambers and has been approved by the New York Municipal Explosives Commission. It will be seen that the two gases are separated until they enter the mixing chamber through the parallel ports of the transformer. Each torch is equipped with 10 tips, which are numbered and permitted a full range of work, and the ground joints facilitate the changing of the tips. Referring to the illustration, *A* is the head piece, *B* the stationary nozzle, *C* the tip, *D* the transformer, *F* expansion mixers, *G* the oxygen

conduit, *H* the illuminating gas conduit, and *E* and *J* are needle valves.

It has not yet been found possible with this system to weld either wrought iron or steel, but the welding of cast iron in medium thicknesses has proven very successful and economical. Steel and wrought iron may be readily cut by this process and steel bars up to 8 in. square have been cut with great success. The process is especially adapted for the smaller sizes of iron castings and is most economical and efficient on brass and aluminium work. It is quite applicable to such work as the repairing of brass castings, the filling in of blow holes and in boiler shops, particularly for the cutting of plates; there are also many opportunities for its use in the electric railroad repair shops as well as in signal work. The process has been developed by E. Raven Rosen-Baum, consulting engineer on high temperature gases, 607 West Forty-third street, New York, and all the apparatus has been patented by him.

### AN AMERICAN IMPRESSION OF ENGLISH TRAINS.

Just then the lighter bumped against the dock. I walked under a long, low train-shed covering four tracks, and then I saw my first English passenger train. I didn't like the looks of the cars. I can prove in a moment by any traveler that our trains are vastly more luxurious. I can see where there isn't heat enough, and where one lavatory for men and women on any train, let alone a first-class one, is an abomination; but, still, and notwithstanding, I say the English railway service is better. Why? Because it's more human; it's more considerate. You aren't driven and urged to step lively and called at in loud, harsh voices, and made to feel that you are being tolerated aboard something that was never made for you at all, but for the employees of the company.

But finally the train was started, and we were off. The track was not so wide as ours, if I am not mistaken, and the little freight cars were positively ridiculous, mere wheelbarrows by comparison with the American type. As for the passenger cars, when I came to examine them, they reminded me of some of our fine street cars that run from, say, Schenectady to Gloversville. They were the first-class cars, too—the English Pullmans. The train started out briskly and you could feel that it did not have the powerful weight to it which the American

train has. An American Pullman creaks significantly, just as a great ship does when it begins to move. An American engine begins to pull slowly because it has something to pull—like a team with a heavy load. I didn't feel that I was in a train half so much as I did that I was in a string of baby carriages.

It was 3:30 when the train began to move, and from the lovely, misty sunshine of the morning the sky had become overcast with low, gray, almost black, rain clouds. I looked at the hills and valleys. They told me we were in Wales. Curiously, as we sped along, first came Wordsworth into my mind, and then Thomas Hardy.

At 4:30 one of the charming English trainmen came and asked if we would have tea in the dining car. We would. We arose and in a few moments were entering one of those dainty little basket cars. The tables were covered with white linen and simple, pretty china and a silver tea service. It wasn't as though you were traveling at all. I felt as though I were stopping at the house of a friend, or as though I were in the cozy corner of some well-known and friendly inn. Tea was served. We ate toast and talked cheerfully.—From "The First Voyage Over," by Theodore Dreiser, in the *Century* for August.

### COMPENSATING QUADRANT CRANE.

The compensating quadrant crane is of the derrick type, with the jib securely fastened at its lower end to two quadrants; in the smaller cranes the jib and the quadrant are cast in one piece. The quadrant is provided with a finished rolling surface and teeth that engage in a rack and roll in a slot on the bottom plate, a frame work being built on the latter. The actuating screws work in bearings in the top connecting piece of the crane, this piece also holding the bearing at the top of the post; the bearing at the bottom of the post is a part of the bottom plate. The actuating screw swings the quadrant by means of a nut which slides on a guide on the top part of the frame. For slewing, the bottom plate is provided with four rollers that roll on a beveled flange on the post plate.

There are two different compensating devices. The first is obtained by the use of two parallel links pivoted at one end near the top of the jib, and at the other end holding two sheaves over which the hoisting ropes run. This end of the links is held by a chain that runs over the sheave at the top of the jib, and is

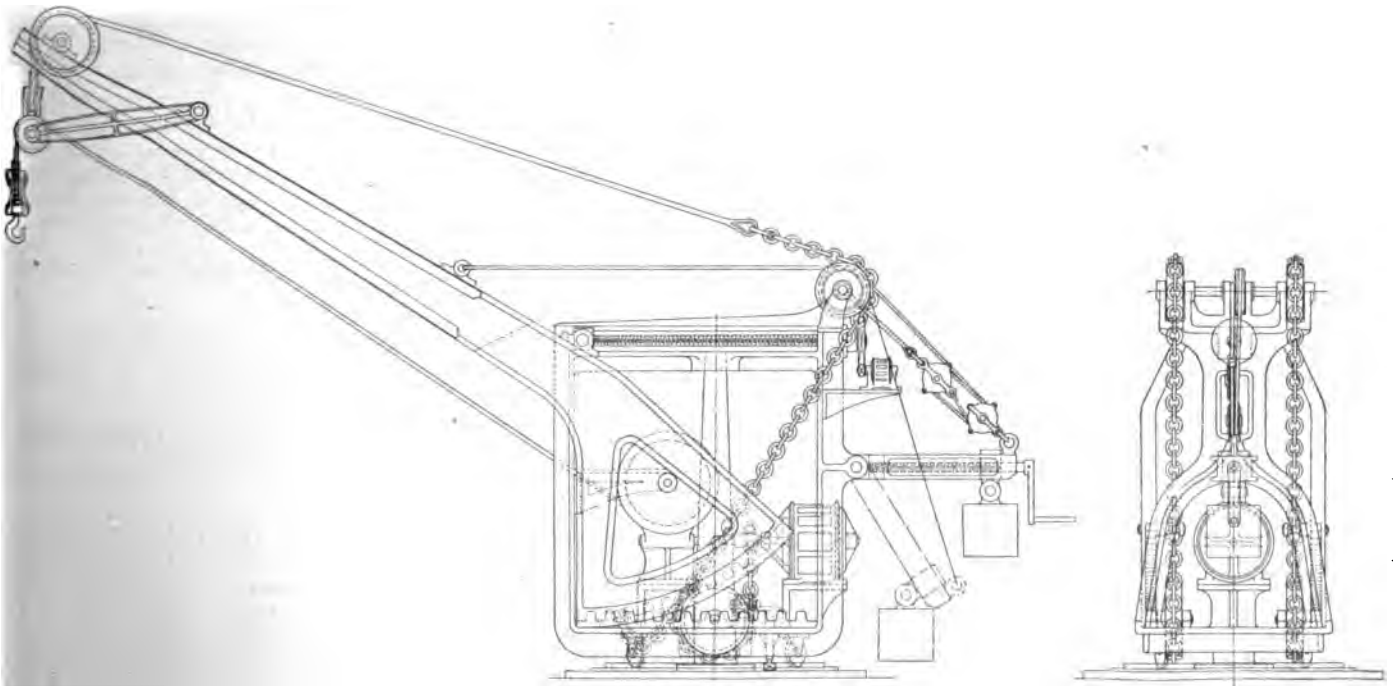

Compensating Quadrant Crane.

connected by means of a rod with a three-arm dog pivoted at the top of the back frame. The other two arms of the dog are connected with the lower back end of the quadrants by means of two chains running over sheaves on the bottom plate. In the second device for compensation, the fixed end of the hoisting rope is fastened to the jib at a suitable point near the top, and from this point runs back and forth over sheaves on the back part of the frame and on the top of the jib.

The hoisting machinery is of the usual kind, made of dimensions suitable for the purpose for which the crane is to be used.



Truck Crane of One-Ton Capacity.

The slewing is done by a system of gears under the bottom plate, which engage an annular rack in the post plate. The derricking is accomplished by means of the actuating screw, which is provided with a worm or spur gear drive; the necessary counterbalancing is accomplished by a weight. The driving power can be of any desired kind, but the cranes are generally provided with electric motors.

This type of crane is readily adaptable for use about scrap yards and also as a wrecking or locomotive crane. It is manufactured by the Welin Marine Equipment Company, Long Island City, N. Y.

**DOUBLE TRACKING IN INDIA.**—The double tracking of the Umballa-Saharanpur section of the North-Western Railway is being steadily proceeded with, and, at the same time, some of the station yards are being remodeled.

**MOTOR BUSES IN LONDON.**—In 1903 there were 3,500 horse omnibuses in use in the streets of London. There are now only 100 in use and it is expected that by the beginning of 1914 this type of vehicle will have been entirely done away with.—*The Engineer*.

**SHIP BUILDING ON THE CLYDE.**—During the first six months of 1913, the Clyde shipbuilders built 127 vessels, aggregating 348,470 tons, which is the largest output on record, exceeding the next largest output, that of the first six months of 1906, by over 12,000 tons.

**EXTINGUISHING FOREST FIRES.**—Ammonia bombs are being tried out on some of the national forests for the purpose of extinguishing forest fires. They are said to have worked well in the case of brush fires where the fire-fighters find difficulty in getting near enough to the burning area to beat out the flames.

## General News.

Oscar Bider, on July 26, made an aeroplane flight from Milan, Italy, to Basel, Switzerland, across the Alps, 160 miles, in three hours and 45 minutes, making one brief halt at Liestal to obtain additional gasolene. He attained a height on the trip of 10,000 ft.

The motorman and conductor of the freight train which ran into a Rochester & Eastern passenger train at Victor, N. Y., on July 19, killing one man and injuring 18 others, have been arrested charged with manslaughter in the second degree, following the verdict of the coroner finding both men negligent.

Engineers, firemen and switchmen employed by the Chicago & Western Indiana and the Belt Railway of Chicago have threatened to call a strike if the roads do not meet their demands for shorter hours and a wage increase. Representatives of the unions have been in conference with the officials of the road for several days.

The White Audit System of checking passenger train collections, which was described in the *Railway Age Gazette* of January 17, 1913, page 112, at the time of its installation on the Chicago, Burlington & Quincy, is to be adopted on August 1, by the Colorado & Southern and the Chicago, Indianapolis & Louisville.

Four laborers were killed in a derailment of a car in a construction train on the Newark branch of the Erie on July 27. The train was rounding a curve at a slow rate of speed when the middle car of the seven-car train left the rails and rolled down a high embankment, carrying with it the four workmen who were riding on the load of cinders.

President Freeman, of the International & Great Northern, in commenting on the crop conditions along the I. & G. N. lines, said that a good wheat crop was harvested and an excellent corn crop made, and that Texas is looking forward to a 6,000,000 bale cotton crop, which will be the largest that has ever been produced in that state. The cotton crop is about three weeks late.

Five coaches of a Denver, Boulder & Western train were overturned at Eldorado, Col., on July 27, and 27 passengers were said to be injured, six of them seriously. The newspaper accounts of the accident say that the last coach of the train was backed off the end of the wye on which it was turning, and in an endeavor to draw this coach back on to the track, three other coaches were overturned.

Isaiah Hale, safety commissioner of the Atchison, Topeka & Santa Fe, has prepared a poster to be displayed in school houses along the company's lines, calling the attention of children to the danger of walking and playing on railway tracks. The poster includes some statistics on trespassing accidents, showing that 20 per cent. of the trespassers killed during last year were children under 14 years of age.

United States Representative Stout has introduced a bill in the lower house of Congress providing for the extension of the second class mail privilege to periodicals published by commercial clubs, chambers of commerce or other organizations not formed for profit, provided these periodicals are published only for the purpose of setting forth or advertising the products, resources or agricultural possibilities of the section in which the periodical is published.

Senator Newlands, of Nevada, has introduced a bill providing for a national waterways commission to have supervision over the expenditure of a proposed annual appropriation of \$60,000,000. The proposed commission is to consist of the president, the secretaries of war, of the interior and of agriculture, and of the chairman of the Interstate Commerce Commission, of the chairman of the Panama canal commission and of the chairman of the board of river regulation.

The Brotherhood of Railroad Trainmen and Order of Railroad Conductors on the Northern Pacific have put to a vote of their members the question of whether or not to strike unless the demands of the trainmen that suburban trainmen and conductors shall receive equal rating pay and promotion with main line employees are met. The company wishes to deal separately with employees on electric lines, while the brotherhoods desire to keep the trainmen in such service in their own organizations.

The New York *Evening Sun* is offering a prize to the commuter who can show the longest record of daily commutation into New York; another to the commuter who has made the greatest mileage in one year, and a third to the commuter who has made the greatest mileage in five years. A commuter laying claim to one of these prizes must substantiate his claim. If the *Sun* can decide the questions that will arise it will qualify to act as judge in a contest to determine what railroad has the longest piece of tangent in the world.

The management of the Missouri, Kansas & Texas has issued a circular to officers and employees announcing that the management of hospital matters will be placed in the hands of the employees contributing to the hospital fund, and two hospital associations will be incorporated, one for the main system, and one for the lines in Texas. Two boards of trustees of seven members each will be organized. The hospital fund has now accumulated a surplus of about \$100,000, which will be divided between the two associations.

#### Earnings of the Steel Corporation.

The report of the United States Steel Corporation for the quarter ended June 30, 1913, shows that the total net earnings were \$41,219,813 after deducting all expenses incident to operation, including those for ordinary repairs and maintenance of plants and fixed charges of subsidiary companies. This compares with \$34,426,801 for the last previous quarter and \$25,102,265 for the corresponding period of last year. This showing has not been surpassed in any quarter since the second quarter of 1907, when the net earnings amounted to \$45,503,705.

#### Japanese Passenger Makes Some Suggestions.

Shikaro Takomoto, "Japanese passenger," has written to the Hon. S. Pacific Company, earnestly asking why "do engineer 9:30 evening p. m. freight train necessary blow whistle with so long lasting of sounds." Takomoto, too, has some suggestions regarding Pullman cars. The letter follows:

"Dear Hon. S. Pacific:—

"I residing in these Suisun City and question, please, do engineer 9:30 evening p. m. freight train necessary blow whistle with so long lasting of sounds for calling back end brakeman if 5 short whistle call would wake my baby and back end brakeman with same effect each departure? Many other trains at crossings raise same long night noises; cannot all lives be safe with less awaking of almost the dead?

"Also recent time of late I travel with hon. employ in lovely electric lights Pullman car "Aliena" and cannot find satisfy place to lose my watch and American eagle (\$10.00) for complete safety. Could not hon. Pullman save 25c. from every gentleman in lower berth rate financial condition by inserting in smoke room wash place, one small safe deposit box convenience (10c. to porter upon arrival at destitution to leave key with it), so saving temptation of robbery under pillow.

"Thanking you for quiet relief to home and very grateful for travel safely. Your truly,

"Shikaro Takomoto, Japanese Passenger."

The Southern Pacific has answered Takomoto and assured him that it will do all it can that "all lives be safe with less awaking of almost the dead."

#### Co-operation to Prevent Car Shortage.

The Sunset-Central Lines of the Southern Pacific Company have prepared a circular letter including suggestions for the prevention of car shortage, which is being sent by all local freight agents to patrons in their respective territories. The circular states that within the next sixty days another period of heavy traffic will be on us and that it will be the aim of the Sunset-Central Lines to so handle the traffic that congestion will not occur and that shippers may be assured of an adequate supply of cars. The co-operation of the shipper is necessary, however, and after discussing some of the phases of car interchange and emphasizing the necessity of such car handling as will keep the company's cars at home, the circular states that shippers may assist in some of the following ways:

By giving as much advance notice as possible of your requirements. If there is no suitable car on hand, opportunity should be given to secure it from another point.

By calling on the agent for his approval before reloading cars

made empty on your tracks. Such cars may or may not properly be used in the direction you desire, and their misuse may necessitate transfer of freight, with consequent delay to your shipment.

By loading cars to the greatest possible percentage of their capacity, and by using your efforts with your customers to induce them to place orders for full car loads. If you use two cars to handle the load of one, you reduce the supply 50 per cent.

By regulating, so far as possible, your inbound shipments so as to avoid receipt of cars in excess of your ability to promptly unload. Congestions which delay your freight and hurt your business are almost always caused by over-shipments. The effect on the car supply is also obvious.

By calling the agent's personal attention at once to any condition which retards the loading or release of cars and which it may be in the power of these lines to correct. Our own deficiencies in facilities or service may be chargeable with a detention for which you are being held responsible.

The circular also includes some extracts from the Car Service and Per Diem Rules and a list of the companies whose cars are considered "home" on the Sunset-Central Lines.

#### The Lazy Box Car.

The Universal Portland Cement Company has long been interested in the subject of maximum loading of freight cars, in order to obtain maximum car efficiency, and has distributed a great deal of literature on the subject to its customers. One of the company's officials, Gordon Wilson, has recently expressed the argument as follows:

Jim Bingham claims with pride that he  
Is busy as a man can be;

He will not stand for loafing around his lumber yard.  
The way he talks is a disgrace,

But that is just because his face,

Like all his property, must work both constantly and hard.

At times, to me, he almost seems  
Inhuman, for he works his teams

Like they were made of metal 'stead of common bone and flesh.  
And all his yardmen and his clerks

Full seven days a week he works,

And then acts disappointed if they aren't all keen and fresh.

One day when I dropped in on Jim,  
A clean cut chap was selling him

A nifty little order of a carload of cement.

But Jim was forcing him to work

To get that order like a Turk,

And though they scrapped and argued, neither one of them  
unbent.

I butted in and asked them why  
Their fool discussion ran so high.

And Jim explained, "This feller is gettin' fresh with me.

I want a hundred-barrel car,

And this young feller goes so far

As tellin' me I ought to buy a hundred seven three."

And then I called the salesman's bluff;

He said there were not cars enough

To carry all the merchandise that people had to ship.

And in that way he plainly showed

Why decent citizens should load

A car to full capacity each time she made a trip.

Well, then I said to Jim, "Old man,

This salesman has a little plan

That ought to make an awful hit with anyone like you.

It drives you wild when people shirk,

So why not make these box cars work

And carry every ounce of freight that they are able to."

And then Jim Bingham saw the light,

"By Gum," said he, "for once you're right,

I never thought of railroad cars in just that way before.

And after this the car for me

Will be a hundred seven three,

I won't let cars loaf on the job with my cement no more."



### The Parcels Post.

The postmaster general, who, with the chairman of the Interstate Commerce Commission, went before the Senate committee on post offices and post roads, is quoted as saying that it is his intention of increasing, as soon as may be, the limit set for the weight of parcels that may go by post to 100 lbs. The Interstate Commerce Commission issued a statement in which it said that it does not consider that the provisions of the parcel post act to the effect that changes may be made by the postmaster general with the consent of the commission necessarily means that hearings should be held on such proposals of the postmaster general. The commission goes on to say that the question of compensation to the carrier for hauling mails is a matter of contract between them and the post office department, in connection with which the commission has no jurisdiction.

### Lehigh Valley Wreck.

At 12:35 a. m. on July 27 a rear end collision occurred between two freight trains near Slatington, Pa., on the main line of the Lehigh Valley. The conductor of the forward train was caught in the caboose and killed, and the wreckage was thrown under the westbound passenger tracks just in front of the Lehigh Valley passenger train No. 5 from New York to Buffalo. The locomotive of the passenger train plowed through the wreckage, but was brought to a stop without any further loss of life.

### Trainmen's Wage Arbitration.

On Saturday of last week the managers' committee agreed to withdraw the eight grievances of the roads which they had previously insisted should be passed upon by the arbitrators at the same time as the demands of the trainmen for increased wages and changes in working conditions. The trainmen and managers' committee thereupon reached an agreement to submit their differences to arbitration, as provided for by the amendment to the Erdman act, and it was announced by the trainmen that the two members to represent them on the arbitration board would be Lucius E. Sheppard, senior vice-president of the Order of Railway Conductors, and Daniel L. Cease, editor of *The Railway Trainman*. The two representatives of the railroads on the board are W. W. Atterbury of the Pennsylvania, and A. H. Smith of the New York Central.

### Railway Mail Pay.

The committee on railway mail pay has issued a statement in part as follows:

Ninety per cent. of all the money paid to the railroads is for the weight of mail carried. The law stipulates that the mail shall be weighed for a typical period at least once every four years and that payment shall be made during the entire period according to the average weights then actually ascertained. In practice, the post office department has construed this law to mean that the mails shall be weighed not oftener than every four years. The result is that though there is a constantly increasing weight of mail, the railroads receive no payment whatever for the increase until the next quadrennial weighing period, when a basis is arrived at which shall govern the payments to be made for the succeeding four years.

An illustration of the injustice of this quadrennial weighing system is in the fact that just after the weighing of the mails in Ohio in 1907, the printing of stamped envelopes and newspaper wrappers was changed from New England to Dayton, Ohio, so that many railroads have been required to handle this traffic for four years without compensation, while other roads have been receiving for the same period compensation for services not performed. This principle is at present working great hardship to many railroads. The parcels post started January 1, 1913, and immediately there was a great increase of mail and a reduction of express matter for which the railroads had been previously paid. Congress has allowed a 5 per cent. increase in pay to compensate for the parcels post, but the records already indicate that the government's postal revenues will increase this year from 20 to 30 per cent. on account of the parcels post.

The government makes no additional payment for speed or for frequency of service. There is no greater pay accorded the

railroads for carrying mails at a speed of 60 miles per hour than for 15 miles per hour. There is no greater pay for 100 trips a day than for one trip a day. The aggregate weight of mail carried, and therefore the pay, is the same, whatever the speed or whatever the frequency with which it is carried.

To facilitate the distribution of mail en route, the railways have provided 1,388 traveling postal cars. The mileage made by full railway post office cars of all sizes in the performance of service during the fiscal year 1912 was 126,798,405. Passenger cars on American railroads the same year yielded revenue of about 25 cents for each mile run. If the railway postal cars had yielded as much per mile, it would have amounted to a total of \$31,699,601.

### Western Roads to Oppose Rate Reductions.

The presidents or receivers of twelve railways operating west of Chicago held a conference in Chicago on July 28, to consider the rate situation, and particularly the recent decisions of the Supreme Court in the state rate cases. At the conclusion of the meeting a statement was given out stating that the reduced rates have been filed under protest and that the roads propose to continue their efforts to have them increased. The statement in full follows:

"The railroads have promptly obeyed the laws and orders in Missouri, Arkansas and Minnesota reducing passenger and freight rates, which were the subject of the recent decisions by the Supreme Court of the United States.

"The 2 cent passenger fare has been put into effect in each state, as well as the reduced freight rates, but the tariffs carrying these rates have been filed under protest. In the cases of a few of the roads the claim that the rates were too low was sustained, and, while these roads were permitted to maintain their rates, and will do so, where competitive conditions may permit, the practical result of the decisions is to affect all lines alike in competitive business, which comprises the greatest part of the traffic involved.

"It must not be understood that the Supreme Court has decided any of these rates to be reasonable. The lower courts, after long and patient hearings, decided in each instance that the rates were unreasonably low, and all that the Supreme Court decided upon this branch of the cases is that further proof should have been produced by the railroads.

"Railroad men have always believed that the 2 cent passenger rate is not enough to pay for the character of passenger service demanded by modern travel, and with the increase in steel equipment, automatic block signals, high speed tracks, new passenger stations, etc., that is constantly required, this is more certainly true now than ever. The freight rate reductions are unjust and unnecessary.

"In the east the trunk lines are asking a 5 per cent. increase in freight rates, and there is much indication that public opinion favors it. West of Chicago the railroads, as a result of these decisions, are facing heavy reductions in many important rates, and there never was a time when reductions in rates were more unwise and called for with less reason than the present.

"Several of these reductions were ordered five or more years ago under conditions of public opinion that have since largely changed. In the meantime the expenses of the railroads have greatly increased, and the cost of new capital for necessary improvements has become almost prohibitive. As a consequence new construction has practically ceased, and investors are gradually withdrawing their funds from railroad securities and turning to other forms of investment.

"Believing that these reductions are not only wrong but untimely and unnecessary, the railroads have put these low rates into effect under protest and propose to continue their efforts to have them increased. New evidence will be carefully prepared to meet the suggestions contained in the opinions of the Supreme Court in case further litigation should become necessary, and consideration is also being given to an appeal to the state authorities and the Interstate Commerce Commission for relief instead of again resorting to the courts."

The statement is signed by: E. P. Ripley, president Atchison, Topeka & Santa Fe; Darius Miller, president Chicago, Burlington & Quincy; B. A. Worthington, president Chicago & Alton; S. M. Felton, president Chicago Great Western; A. J. Earling, president Chicago, Milwaukee & St. Paul; H. U. Mudge, president Chicago, Rock Island & Pacific; J. A. Johnson, president

Kansas City Southern; B. F. Bush, president Missouri Pacific; F. H. Britton, president St. Louis Southwestern; C. E. Schaff, president Missouri, Kansas & Texas; C. W. Nixon, receiver St. Louis & San Francisco; F. A. Delano, receiver Wabash.

#### Rear End Collision on the Pennsylvania.

On July 30 westbound passenger train No. 13, on the Pennsylvania main line, ran into the rear end of westbound passenger train No. 15 near Tyrone, Pa. The engineman of No. 13 was killed and a number of passengers were injured, some of them seriously. First accounts say that No. 15 had just called in the rear flagman and was starting forward when No. 13 came around a curve about ten cars length behind the rear end.

#### Bulletin of Commendation and Discipline.

Following are the notices of commendation on one division of the Pennsylvania Railroad for a single month, and a few selected notices of discipline for the same month:

##### COMMENDATION.

Engineman commended for prompt action in stopping train after discovering board projecting from car roof.

Engineman commended for prompt action in notifying proper persons after discovering that brake rigging was down under car in passing freight train.

Engineman and fireman each commended for keeping engine in a clean condition.

Crossing watchman commended for prompt action in flagging freight train when he observed fire flying from truck of car.

Clerk commended for prompt action in notifying proper persons when he discovered, on his way home from work, truck side cracked on car standing on siding.

Leverman commended for prompt action in notifying proper persons when he discovered coal on track. (It was found that a drop bottom was down under a car in a passing freight train.)

Telegraph operator commended for prompt action in notifying proper persons when he observed a car leaning in passing freight train. (It was found that truck under car was broken.)

Telegraph operator and leverman each commended for prompt action in notifying proper persons when they discovered hot journal on car in passenger train.

Telegraph operator commended for prompt action in notifying proper persons when he observed that something was dragging under car in passing freight train. (It was found that a drop bottom was down under car and lading partly lost.)

Telegraph operator commended for prompt action in setting up route from No. 3 to No. 4 track when he thought that a freight train on No. 3 track would not be able to get stopped before fouling route set up for train No. 24 from No. 3 to No. 1 track, the freight train having run by stop signal.

Track watchman commended for prompt action in notifying proper persons when he discovered something dragging under car in passing freight train. (It was found that a hog rod was down under car.)

Air brake repairman commended for prompt action in closing down engine, in the plumbing shop, when the governor belt broke, saving the engine from possible damage and employees from personal injury.

Engine house foreman commended for designing a device for spraying hot ashes, which has proven to be efficient and a labor saver.

Engine house foreman commended for designing a stop device for pneumatic tube system of transmission of messages, which has proven useful and efficient.

Air brake inspector commended for designing an air operated clamp for holding train line feed valves to test rack, which has proven efficient as a time saver.

Gang leader commended for designing an air operated water pump for increasing the pressure on a valve testing rack, which has proven efficient.

Freight flagman commended for prompt action in having train stopped when he observed brake bar down on car in his train.

Switch tender commended for prompt action in notifying proper persons when he discovered something dragging under car in passing freight train. (It was found that brake rigging was down under car.)

Switch tender commended for prompt action in notifying

proper persons when he discovered car door open in passing freight train.

Switch tender commended for prompt action in notifying proper persons when he discovered something dragging under car in passenger train. (Train was stopped and it was found that brake rigging was down under baggage car.)

Freight conductor commended for prompt action after discovering fire in town of Blank, to warn the people by having enginemen sound whistle and taking proper steps to protect company property and notifying train despatcher.

Patrolman commended for prompt action in flagging freight train when he observed that a steam shovel had stopped on crossing on account of overhead wires, averting a possible accident.

##### DISCIPLINE.

Freight flagman suspended two days for throwing refuse on ground instead of putting it in garbage can.

Freight conductor suspended seven days for failing to make effort to clear obstruction from main track.

Freight conductor suspended seven days, freight brakeman suspended seven days and freight brakeman censured, for failing to give their duties proper attention and observe hot journal on car in train.

Car repairman and lamp attendant each suspended two days for operating elevator, instead of waiting for elevator attendant.

Car Repairman suspended four days for erasing inspector's marks from car without making repairs.

Passenger brakeman suspended two days for allowing lady passenger to board train in error, her destination being a point on another division.

Passenger brakeman suspended two days for leaving his train before being properly relieved at terminal.

Passenger conductor censured and passenger brakeman suspended two days for using poor judgment and lack of tact in failing to comply with a reasonable request from passenger.

Passenger brakeman suspended two days for failing to report for examination after being notified to do so.

Passenger conductor censured for failing to sign register upon arrival at Blank.

Two passenger conductors each censured for lifting transportation prematurely.

Passenger conductor suspended two days for lifting mileage in excess.

#### Safety First Work on the Frisco.

C. H. Baltzell, superintendent of the Ozark division of the St. Louis & San Francisco, has written for *The Frisco Man* a description of some of the methods used in reducing the number of accidents on that division 63 per cent. in the last year, which resulted in the division winning the Safety First honors for the best showing in personal injury reductions on the road. Some extracts from the statement are as follows:

I was fortunate in selecting my committee, securing men who had Safety First interests deeply at heart; men ever on the lookout for defects in equipment, as well as on the lookout for men practicing dangerous habits in their work.

Many unique methods were used to secure these good results. One at Thayer, Mo., to prevent the evil of boys hopping trains, was the installation of a platform, steps and springboard, together with a dressing room, at the old swimming hole in Warm Fork, opposite superintendent's office. I fixed this up for the boys and we all went swimming occasionally. I have counted as many as forty boys between the ages of eight and eighteen in the swimming hole at one time. I took occasion frequently to talk briefly to these boys upon the evils and dangers of hopping trains, and asked them, in consideration of fixing up the splendid swimming hole, that they would promise not to hop and ride trains through the Thayer yards; they have kept their promise.

Not only did the boys at Thayer heed the warning, but at a number of other stations along the road, where I have numerous boy friends. It has always been my practice to caution the boys about the bad habit of hopping trains, with result that during the eleven months in which we were struggling for the Safety First honors, I did not have a boy injured on the Ozark division.

At our meetings, which are held every Monday afternoon at Thayer on subjects of train rules and mechanical items of interest, the men have attended with remarkable regularity and showed their interest in these meetings by coming prepared to take active part in same.

The Safety First slogan has been kept continually before our men, and they have received it in loyal, manly spirit.

In all my athletic career no contest was ever entered into with any more spirit or determination to win than in this contest, for the principal reason that so many are benefited by results. When we stop to consider that in eleven months on the Ozark division alone, there was a reduction of 63 per cent. in the number of men hurt—and we have every reason to believe that some of them would have been fatal—the knowledge of such results, to my mind, is sufficient for any and all the work which might have been expended.

I have found in connection with this work, that in making such a strong feature of Safety First practices and habits, getting the men interested, that we have been getting their minds concentrated in the right direction. I have found that our men in all departments have become more efficient in their particular line of work, because of the great educational features of this movement.

#### Society of Railway Financial Officers.

The annual meeting of the Society of Railway Financial Officers will be held at the Hotel Moraine, Highland Park, Ill., September 23-25.

#### Demurrage in Australia.

Every trader would like to see demurrage abolished. All sorts of arguments are invented against the practice. One of the latest dodges to evade it is the request to the railway commissioners asking them not to charge demurrage on Foundation Day, which is a national holiday. The commissioners have, however, declined to consider the request. This is as it should be unless the commissioners wanted to treat the railways as a philanthropic instead of a commercial undertaking. It stands to reason that if traders did not pay their legitimate dues in order to support the railway undertaking of the state, the ordinary taxpayer would have, directly or indirectly, to subscribe to the transportation cost of merchandise of individual traders who would sell and enjoy the profits.

#### MEETINGS AND CONVENTIONS.

The following list gives names of secretaries, dates of next or regular meetings, and places of meeting.

- AIR BRAKE ASSOCIATION.—F. M. Nellis, 53 State St., Boston, Mass.
- AMERICAN ASSOCIATION OF DEMURRAGE OFFICERS.—A. G. Thomason, Boston, Mass. Convention, May 19, 1914, St. Louis.
- AMERICAN ASSOCIATION OF GENERAL PASSENGER AND TICKET AGENTS.—W. C. Hope, New York. Annual meeting, October 14-15, Philadelphia, Pa.
- AMERICAN ASSOCIATION OF FREIGHT AGENTS.—R. O. Wells, East St. Louis, Ill.
- AMERICAN ASSOCIATION OF RAILROAD SUPERINTENDENTS.—E. H. Harman, St. Louis, Mo.; 3d Friday of March and September.
- AMERICAN ELECTRIC RAILWAY ASSOCIATION.—H. C. Donecker, 29 W. 39th St., New York.
- AMERICAN ELECTRIC RAILWAY MANUFACTURERS' ASSOC.—H. G. McConnaughey, 165 Broadway, New York. Meetings with Am. Elec. Ry. Assoc.
- AMERICAN RAILWAY ASSOCIATION.—W. F. Allen, 75 Church St., New York. Next meeting, November 19, 1913, Chicago.
- AMERICAN RAILWAY BRIDGE AND BUILDING ASSOCIATION.—C. A. Lichty, C. & N. W., Chicago. Convention, October 21-24, 1913, Montreal.
- AMERICAN RAILWAY ENGINEERING ASSOCIATION.—E. H. Fritch, 900 S. Michigan Ave., Chicago.
- AMERICAN RAILWAY MASTER MECHANICS' ASSOCIATION.—J. W. Taylor, Old Colony building, Chicago.
- AMERICAN RAILWAY TOOL FOREMEN'S ASSOCIATION.—A. R. Davis, Central of Georgia, Macon, Ga.
- AMERICAN SOCIETY FOR TESTING MATERIALS.—Prof. E. Marburg, University of Pennsylvania, Philadelphia, Pa.
- AMERICAN SOCIETY OF CIVIL ENGINEERS.—C. W. Hunt, 220 W. 57th St., New York; 1st and 3d Wed., except June and August, New York.
- AMERICAN SOCIETY OF ENGINEERING CONTRACTORS.—J. R. Wenlinger, 11 Broadway, New York; 2d Tuesday of each month, New York.
- AMERICAN SOCIETY OF MECHANICAL ENGINEERS.—Calvin W. Rice, 29 W. 39th St., New York.
- AMERICAN WOOD PRESERVERS' ASSOCIATION.—F. J. Angier, B. & O., Baltimore, Md. Next convention, January 20-22, 1914, New Orleans, La.
- ASSOCIATION OF AMERICAN RAILWAY ACCOUNTING OFFICERS.—C. G. Phillips, 143 Dearborn St., Chicago. Annual meeting, May 28, Atlantic City, N. J.
- ASSOCIATION OF RAILWAY CLAIM AGENTS.—J. R. McSherry, C. & E. I., Chicago.
- ASSOCIATION OF RAILWAY ELECTRICAL ENGINEERS.—Jos. A. Andreucetti, C. & N. W. Ry., Chicago. Annual convention, October 18-24, Chicago.
- ASSOCIATION OF RAILWAY TELEGRAPH SUPERINTENDENTS.—P. W. Drew, 112 West Adams St., Chicago.
- ASSOCIATION OF TRANSPORTATION AND CAR ACCOUNTING OFFICERS.—G. P. Conard, 75 Church St., New York.
- ASSOCIATION OF WATER LINE ACCOUNTING OFFICERS.—W. R. Evans, Chamber of Commerce, Buffalo, N. Y. Annual meeting, October 8, Philadelphia, Pa.
- BRIDGE AND BUILDING SUPPLY MEN'S ASSOCIATION.—H. A. Neally, Joseph Dixon Crucible Co., Jersey City, N. J. Meeting with American Railway Bridge and Building Association.
- CANADIAN RAILWAY CLUB.—James Powell, Grand Trunk Ry., Montreal, Que.; 2d Tuesday in month, except June, July and Aug., Montreal.
- CANADIAN SOCIETY OF CIVIL ENGINEERS.—Clement H. McLeod, 413 Dorchester St., Montreal, Que.; Thursday, Montreal.
- CAR FOREMEN'S ASSOCIATION OF CHICAGO.—Aaron Kline, 841 North 50th Court, Chicago; 2d Monday in month, Chicago.
- CENTRAL RAILWAY CLUB.—H. D. Vought, 95 Liberty St., New York; 2d Thurs. in Jan. and 2d Fri. in March, May, Sept., Nov., Buffalo, N. Y.
- CIVIL ENGINEERS' SOCIETY OF ST. PAUL.—L. S. Pomeroy, Old State Capitol building, St. Paul, Minn.; 2d Monday, except June, July, August and September, St. Paul.
- ENGINEERS' SOCIETY OF PENNSYLVANIA.—E. R. Dasher, Box 704, Harrisburg, Pa.; 1st Monday after 2d Saturday, Harrisburg, Pa.
- ENGINEERS' SOCIETY OF WESTERN PENNSYLVANIA.—E. K. Hiles, Oliver building, Pittsburgh; 1st and 3d Tuesday, Pittsburgh, Pa.
- FREIGHT CLAIM ASSOCIATION.—Warren P. Taylor, Richmond, Va.
- GENERAL SUPERINTENDENTS' ASSOCIATION OF CHICAGO.—E. S. Koller, 226 W. Adams St., Chicago; Wed. preceding 3d Thurs., Chicago.
- INTERNATIONAL RAILWAY CONGRESS.—Executive Committee, 11, rue de Louvain, Brussels, Belgium. Convention, 1915, Berlin.
- INTERNATIONAL RAILWAY FUEL ASSOCIATION.—C. G. Hall, 922 McCormick building, Chicago.
- INTERNATIONAL RAILWAY GENERAL FOREMEN'S ASSOCIATION.—Wm. Hall, 829 West Broadway, Winona, Minn.
- INTERNATIONAL RAILROAD MASTER BLACKSMITHS' ASSOCIATION.—A. L. Woodworth, Lima, Ohio. Annual meeting, August 18, Richmond, Va.
- MAINTENANCE OF WAY & MASTER PAINTERS' ASSOCIATION OF THE UNITED STATES AND CANADA.—W. G. Wilson, Lehigh Valley, Easton, Pa.
- MASTER BOILER MAKERS' ASSOCIATION.—Harry D. Vought, 95 Liberty St., New York.
- MASTER CAR BUILDERS' ASSOCIATION.—J. W. Taylor, Old Colony building, Chicago.
- MASTER CAR AND LOCOMOTIVE PAINTERS' ASSOC. OF U. S. AND CANADA.—A. P. Danc, E. & M., Reading, Mass. Annual meeting, September 9-12, Ottawa, Can.
- NATIONAL RAILWAY AFFLIANCE ASSOC.—Bruce V. Crandall, 537 So. Dearborn St., Chicago. Meetings with Am. Ry. Eng. Assoc.
- NEW ENGLAND RAILROAD CLUB.—W. E. Cade, Jr., 683 Atlantic Ave., Boston, Mass.; 2d Tuesday in month, except June, July, Aug. and Sept., Boston.
- NEW YORK RAILROAD CLUB.—H. D. Vought, 95 Liberty St., New York; 3d Friday in month, except June, July and August, New York.
- NORTHERN RAILROAD CLUB.—C. L. Kennedy, C. M. & St. P., Duluth, Minn.; 4th Saturday, Duluth.
- PEORIA ASSOCIATION OF RAILROAD OFFICERS.—M. W. Rotchford, Union Station, Peoria; 2d Thursday.
- RAILROAD CLUB OF KANSAS CITY.—C. Manlove, 1008 Walnut St., Kansas City, Mo.; 3d Friday in month, Kansas City.
- RAILWAY BUSINESS ASSOCIATION.—Frank W. Noxon, 2 Rector St., New York. Annual dinner, second week in December, 1913, New York.
- RAILWAY CLUB OF PITTSBURGH.—J. B. Anderson, Penna. R. R., Pittsburgh, Pa.; 4th Friday in month, except June, July and August, Pittsburgh.
- RAILWAY ELECTRICAL SUPPLY MANUFACTURERS' ASSOC.—J. Scribner, 1021 Monadnock Block, Chicago. Meetings with Assoc. Ry. Elec. Engrs.
- RAILWAY FIRE PROTECTION ASSOCIATION.—C. B. Edwards, Mobile & Ohio, Mobile, Ala. Next meeting, October 7, Chicago.
- RAILWAY GARDENING ASSOCIATION.—J. S. Butterfield, Lee's Summit, Mo. Next meeting, August 12-15, Nashville, Tenn.
- RAILWAY DEVELOPMENT ASSOCIATION.—W. Nicholson, Kansas City Southern, Kansas City, Mo.
- RAILWAY SIGNAL ASSOCIATION.—C. C. Rosenberg, Bethlehem, Pa. Convention, October 14, Nashville, Tenn.
- RAILWAY STOREKEEPERS' ASSOCIATION.—J. P. Murphy, Box C, Collinwood, Ohio.
- RAILWAY SUPPLY MANUFACTURERS' ASSOC.—J. D. Conway, 2135 Oliver bldg., Pittsburgh, Pa. Meetings with M. M. and M. C. B. Assoc.
- RAILWAY TEL. AND TEL. AFFLIANCE ASSOC.—W. E. Harkness, 284 Pearl St., New York. Meetings with Assoc. of Ry. Tel. Supa.
- RICHMOND RAILROAD CLUB.—F. O. Robinson, Richmond, Va.; 2d Monday except June, July and August.
- ROADMASTERS' AND MAINTENANCE OF WAY ASSOCIATION.—L. C. Ryan, C. & N. W., Sterling, Ill. Convention, September 8-12, 1913, Chicago.
- ST. LOUIS RAILWAY CLUB.—B. W. Frauenthal, Union Station, St. Louis, Mo.; 2d Friday in month, except June, July and Aug., St. Louis.
- SIGNAL AFFLIANCE ASSOCIATION.—F. W. Edmonds, 3868 Park Ave., New York. Meeting with annual convention Railway Signal Association.
- SOCIETY OF RAILWAY FINANCIAL OFFICERS.—C. Nyquist, La Salle St. Station, Chicago. Annual meeting, September 23-25, Chicago.
- SOUTHERN ASSOCIATION OF CAR SERVICE OFFICERS.—E. W. Sandwich, A. & W. P. Ry., Montgomery, Ala.
- SOUTHERN & SOUTHWESTERN RAILWAY CLUB.—A. J. Merrill, Grant bldg., Atlanta, Ga.; 3d Thurs., Jan., March, May, July, Sept., Nov., Atlanta.
- TOLEDO TRANSPORTATION CLUB.—J. G. Macomber, Woolson Spice Co., Toledo, Ohio; 1st Saturday, Toledo.
- TRACK SUPPLY ASSOCIATION.—W. C. Kidd, Ramapo Iron Works, Hillsburn, N. Y. Meeting with Roadmasters' and Maintenance of Way Association.
- TRAFFIC CLUB OF CHICAGO.—W. H. Wharton, La Salle Hotel, Chicago.
- TRAFFIC CLUB OF NEW YORK.—C. A. Swope, 290 Broadway, New York; last Tuesday in month, except June, July and August, New York.
- TRAFFIC CLUB OF PITTSBURGH.—D. L. Wells, Erie, Pittsburgh, Pa.; meetings monthly, Pittsburgh.
- TRAFFIC CLUB OF ST. LOUIS.—A. F. Versen, Mercantile Library building, St. Louis, Mo. Annual meeting in November. Noonday meetings October to May.
- TRAIN DISPATCHERS' ASSOCIATION OF AMERICA.—J. F. Mackie, 7042 Stewart Ave., Chicago.
- TRANSPORTATION CLUB OF BUFFALO.—J. M. Sells, Buffalo; first Saturday after first Wednesday.
- TRANSPORTATION CLUB OF DETROIT.—W. R. Hurley, L. S. & M. S., Detroit, Mich.; meetings monthly.
- TRAVELING ENGINEERS' ASSOCIATION.—W. O. Thompson, N. Y. C. & H. R., East Buffalo, N. Y. Annual meeting, August, 1913, Chicago.
- UTAH SOCIETY OF ENGINEERS.—R. B. Ketchum, University of Utah, Salt Lake City, Utah; 3d Friday of each month, except July and August.
- WESTERN CANADA RAILWAY CLUB.—W. H. Rosevear, P. O. Box 1707, Winnipeg, Man.; 2d Monday, except June, July and August, Winnipeg.
- WESTERN RAILWAY CLUB.—J. W. Taylor, Old Colony building, Chicago; 3d Tuesday of each month, except June, July and August.
- WESTERN SOCIETY OF ENGINEERS.—J. H. Warder, 1735 Monadnock Block, Chicago; 1st Monday in month, except July and August, Chicago.

# Traffic News.

The Seaboard Air Line has put in regular operation the Orangeburg Railroad, which runs from North, S. C., to Orangeburg, 17 miles.

The Chicago, Milwaukee & St. Paul has announced that its new line from Plummer, Idaho, to Spokane, Wash., will be opened on Monday, September 1.

The Traffic Club of Chicago held an all-day picnic at Dellwood Park, near Joliet, Ill., on Thursday, July 31. A feature of the program was a baseball game between teams representing the Traffic Club of Chicago and the St. Louis Traffic Club.

The Chicago Great Western has announced that during the present summer it will try the experiment of maintaining a three-cent fare in the State of Minnesota when other competing roads are carrying passengers at two cents a mile. The Great Western has been exempted from the operation of the two cent fare law temporarily.

At a meeting of the executive committee of the Western Passenger Association last week it was decided to refer to the

advanced freight rates at the time that it denied a reopening of the rate advance cases in 1910, might be postponed indefinitely. The proper proceeding for the railroads was to file tariffs showing increases in class and commodity rates to take effect on September 15. These increases amount to about 5 per cent. It is estimated that it will cost the eastern roads about \$250,000 to prepare the new tariffs. The commission can then refuse to permit these tariffs to go into effect, but must then give the roads a chance to justify the proposed increases.

## Summary of Revenues and Expenses of Steam Roads In May.

The Bureau of Railway Economics' summary of revenues and expenses and comments thereon for May, 1913, are as follows: The railways whose returns are included in this summary operate 220,897 miles of line, or about 90 per cent. of the steam railway mileage in the United States. Total operating revenues for the month of May, 1913, amounted to \$255,127,573. Compared with May, 1912, the total operating revenues show an increase of \$9,090,461. These total operating revenues per mile of line averaged \$1,155 in May, 1913, and \$1,031 in May, 1912, an increase of \$124 or 12.0 per cent. Freight revenue per mile increased 14.8 per cent. and passenger revenue per mile 6.2 per cent.

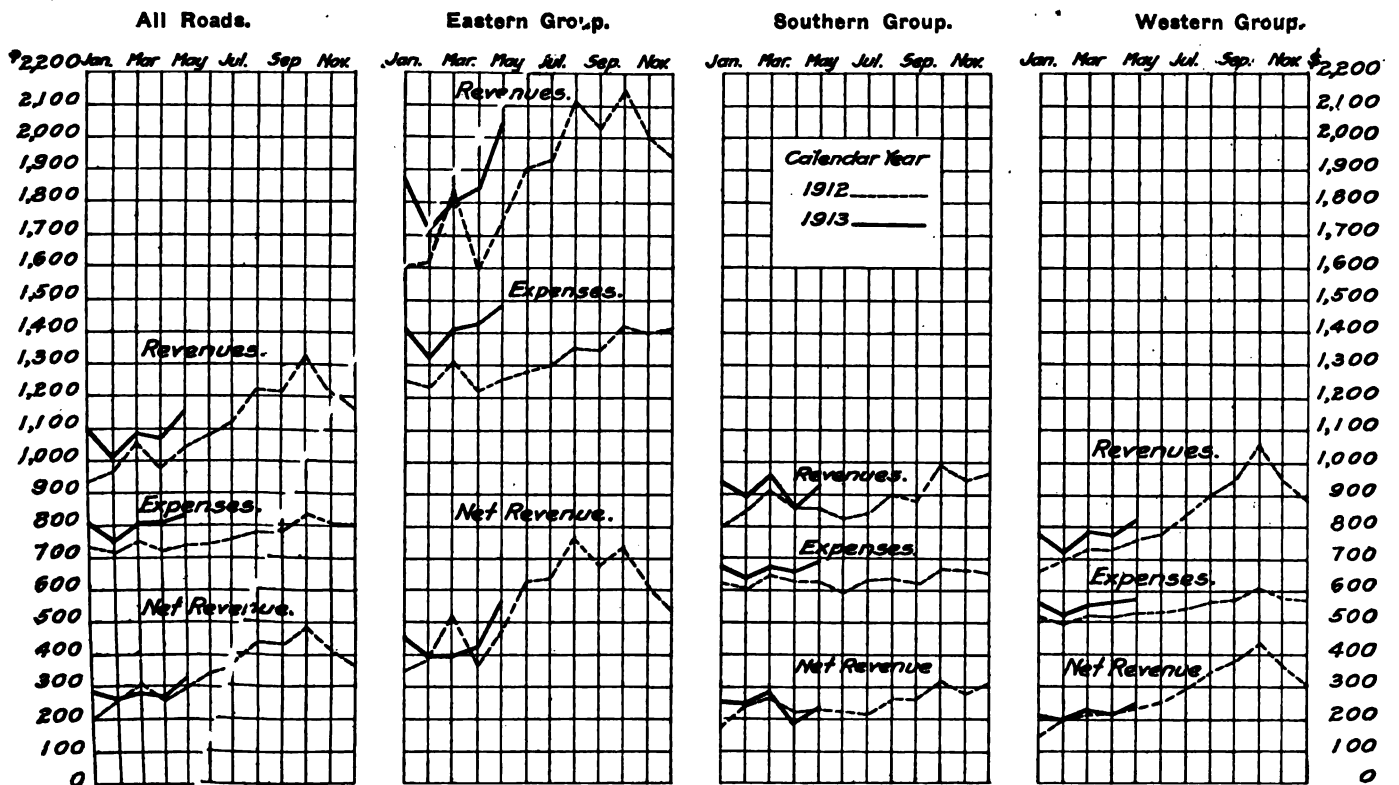

Monthly Revenues and Expenses Per Mile of Line in 1912 and 1913.

Pullman company a proposal to adopt some rule that will curtail the abuse of the privilege of advance reservations of sleeping car accommodations. It is proposed to adopt some plan, such as a time limit within which reserved accommodations must be claimed and paid for, so that railways will not be left with such accommodations on their hands at the last minute after having turned away passengers because no space was available.

The Hamburg-American Steamship Company has issued a statement saying that a renewal of the North Atlantic pool agreement, which expires this year, on the present basis is a business impossibility to all the continental steamship companies, including the North German Lloyd. The Hamburg-American claims that the withdrawal of the Canadian Pacific and the Allan Line from the pool gave these companies an unfair advantage. The trouble apparently is that the Hamburg-American company wants to get as large a percentage of the immigrant traffic as is given to the North German Lloyd.

## Freight Rate Advances.

The attorneys for the eastern railroads have decided that since the investigation, which the Interstate Commerce Commission announced that it would make into the necessity for

Operating expenses amounted to \$183,524,141. This was \$22,228,737 more than for May, 1912. These operating expenses per mile of line averaged \$831 in May, 1913, and \$736 in May, 1912, an increase of \$95 per mile, or 12.9 per cent.

Net operating revenue amounted to \$71,603,432. This was \$6,861,724 more than for May, 1912. Net operating revenue per mile of line averaged \$324 in May, 1913, and \$295 in May, 1912, an increase of \$29 per mile, or 9.8 per cent.

Taxes for the month of May amounted to \$10,586,402, or \$48 per mile, an increase of 6.3 per cent. over May, 1912.

Operating income averaged \$277 per mile of line, and in May, 1912, \$250, thus increasing \$27, or 10.8 per cent. Operating income for each mile of line for each day in May averaged \$8.93 and for May, 1912, \$8.06.

The operating ratio for May was 71.9 per cent., which is comparable with 75.4 per cent. in April, 1913, and 71.4 per cent. in May, 1912.

The railways of the eastern district show an increase in total operating revenues per mile of line as compared with May, 1912, of 17.0 per cent., the railways of the southern district an increase of 7.8 per cent., and the railways of the western district an increase of 8.7 per cent. Operating expenses per mile increased 16.9 per cent. on the eastern railways, 10.2 per cent. on the

southern railways, and 10.0 per cent. on the western railways. For the Eastern railways net operating revenue per mile increased 17.2 per cent., for the southern railways it increased 1.2 per cent., and for the western railways it increased 5.8 per cent. The increase in taxes per mile was 7.4 per cent. in the eastern district, 5.7 per cent. in the southern district, and 5.6 per cent. in the western district. Operating income per mile increased 19.3 per cent. in the East, increased 0.6 per cent. in the South, and increased 6.4 per cent. in the West.

Comparison of the returns for the 11 months of the fiscal year 1913 with those of the corresponding months of the previous fiscal year reveals an increase in total operating revenues per mile of 9.7 per cent., an increase in operating expenses per mile of 9.6 per cent., and an increase in net operating revenue per mile of 9.8 per cent. This net operating revenue per mile of the eastern railways increased 8.0 per cent. as compared with the corresponding period of the previous year, that of the southern railways

to date. The following table shows the per cent. of operating revenues consumed by each class of expenses:

PER CENT. OF TOTAL OPERATING EXPENSES.

	May,		Fiscal year ended June 30,		Calendar year ended December 31,	
	1913.	1912.	1912.	1911.	1912.	1911.
Maintenance of way and structures	15.2	14.5	12.7	12.9	12.8	12.7
Maintenance of equipment	17.1	16.0	15.8	15.5	16.0	15.7
Traffic expenses	2.0	2.2	2.2	2.2	2.0	2.1
Transportation expenses	35.2	36.0	35.9	35.5	35.5	35.4
General expenses	2.4	2.7	2.5	2.5	2.4	2.5
Total operating expenses.....	71.9	71.4	69.1	68.6	68.7	68.4

-Car Location.

The accompanying table, which is taken from bulletin No. 8 of the American Railway Association, gives a summary of freight car location by groups on July 1, 1913.

CAR LOCATION ON JULY 1, 1913.

	N.Y., N.J., Ohio, Ind., Va., Ky., Penn., Iowa, Mont., Wyo., Texas, Oregon,		Del., Md., Mich., W. Va., Miss., Ala., Ga., Fla.		Ill., Wis., Minn., Neb., Mo., Ark.		La., New Mexico, Cal., Ariz.		Idaho, Nev., Canadian Lines.		Grand Total.			
	New England.	Pa.	Pa.	Carolina.	Ala.	Fla.	Ill.	Wis.	Minn.	Dakota.		Mo., Ark.	La., New Mexico.	Cal., Ariz.
Total Cars Owned	87,838	681,344	273,709	202,718	166,786	460,073	16,936	154,250	30,923	131,490	121,766	2,327,832		
Home Cars on Home Roads	41,808	394,795	106,837	106,566	86,007	315,283	5,551	84,958	14,265	76,020	85,236	7,316,406		
Home Cars on Foreign Roads	46,030	286,549	166,872	96,152	80,779	144,810	11,385	70,192	16,658	55,470	36,529	1,011,426		
Foreign Cars on Home Roads	50,961	305,486	224,229	76,710	65,432	172,046	8,372	64,688	19,775	50,753	43,185	1,081,637		
Total Cars on Line	92,769	700,281	331,066	183,276	151,439	487,309	13,923	140,746	34,040	126,773	128,421	2,398,043		
Excess or Deficiency	4,931	18,937	57,357	*19,442	*15,347	27,236	*3,013	*5,504	3,117	*4,717	6,656	70,211		
Surplus	1,404	7,311	3,820	4,729	2,499	10,964	835	14,171	2,238	17,198	5,571	70,740		
Shortage	746	823	465	1,989	619	525	63	500	33	197	1,076	7,936		
Shop Cars—														
Home Cars in Home Shops	4,799	38,940	18,685	12,242	15,457	24,312	687	11,193	2,064	5,711	3,963	138,953		
Foreign Cars in Home Shops	899	9,172	8,053	2,247	2,113	4,757	490	1,949	851	2,573	599	35,703		
Total Cars in Shops	5,698	48,112	26,738	14,489	17,570	29,069	1,177	13,142	2,915	8,284	4,562	171,756		
Per Cent. to Total Cars Owned—														
Home Cars on Home Roads	47.60	57.94	39.03	52.57	51.57	68.52	32.78	54.49	46.13	57.81	70.00	56.55		
Total Cars on Line	102.39	102.78	120.87	90.41	90.80	105.92	82.21	95.15	110.08	96.41	105.46	103.02		
Home Cars in Home Shops	5.47	5.71	7.30	6.04	9.27	5.66	4.06	7.26	6.68	4.34	3.26	6.06		
Foreign Cars in Home Shops	1.02	1.35	3.15	1.11	1.26	1.11	2.89	1.26	2.75	1.96	.49	1.48		
Total Cars in Shops	6.49	7.06	10.45	7.15	10.53	6.77	6.95	8.52	9.43	6.30	3.75	7.54		

\*Denotes deficiency.

increased 3.9 per cent., and that of the western railways increased 14.0 per cent.

When the returns for the five months of the calendar year 1913 are compared with those of the corresponding months of 1912, they show an increase in total operating revenues per mile of 9.4 per cent., an increase in operating expenses per mile of 10.0 per cent., and an increase in net operating revenue per mile of 7.6 per cent. This net operating revenue per mile increased 5.9 per cent. in the eastern district as compared with the corresponding period of the previous year, increased 7.3 per cent. in the southern district, and increased 9.8 per cent. in the western district.

The diagram shows the variation in operating revenues, operating expenses and net operating revenue per mile for the separate months of the calendar year 1912 and of the calendar year 1913

Car Surpluses and Shortages.

Arthur Hale, chairman of the committee on relations between railroads of the American Railway Association, in presenting statistical bulletin No. 147-A, giving a summary of car surpluses and shortages by groups from April 11, 1912, to July 15, 1913, says: The total surplus on July 15, 1903, was 76,280 cars; on June 30, 1913, 70,740 cars; and on July 18, 1912, 75,389 cars. Compared with the preceding period there is an increase in the total surplus of 5,540 cars, of which 426 is in box, 137 in flat, 2,148 in coal and 2,829 in miscellaneous cars. The increase in box car surplus is in groups 1 (New England lines), 2 (New York, New Jersey, Delaware, Maryland and Eastern Pennsylvania); 3 (Ohio, Indiana, Michigan and Western Pennsylvania); 6 (Iowa, Illinois, Wisconsin and Minnesota), and

CAR SURPLUSES AND SHORTAGES.

Date.	No. of roads.	Surpluses					Shortages				
		Box.	Flat.	Coal gondola and hopper.	Other kinds.	Total.	Box.	Flat.	Coal, gondola and hopper.	Other kinds.	Total.
Group *1—July 15, 1913.....	7	528	600	112	25	1,265	0	26	58	27	111
" 2— " 15, 1913.....	34	1,763	31	1,445	368	3,607	200	0	217	0	417
" 3— " 15, 1913.....	32	4,971	383	3,172	2,480	11,006	76	2	178	661	917
" 4— " 15, 1913.....	13	3,032	267	851	1,032	5,182	170	344	1,050	0	1,565
" 5— " 15, 1913.....	27	1,266	1	535	520	2,322	250	254	110	10	614
" 6— " 15, 1913.....	32	7,243	331	1,717	4,966	14,257	953	74	37	53	1,074
" 7— " 15, 1913.....	5	97	21	268	166	552	731	0	0	11	784
" 8— " 15, 1913.....	21	6,273	184	2,601	3,827	12,885	324	4	46	5	385
" 9— " 15, 1913.....	13	1,049	191	330	925	2,495	153	0	5	27	163
" 10— " 15, 1913.....	21	5,122	1,088	2,172	8,766	17,148	127	37	125	4	416
" 11— " 15, 1913.....	6	3,767	124	0	1,670	5,561	177	180	0	2	429
Total .....	211	35,111	3,221	13,203	24,745	76,280	3,161	921	1,826	96	6,875

\*Group 1 is composed of New England lines; Group 2—New York, New Jersey, Delaware, Maryland and Eastern Pennsylvania lines; Group 3—Ohio, Indiana, Michigan and Western Pennsylvania lines; Group 4—West Virginia, Virginia, North and South Carolina lines; Group 5—Kentucky, Tennessee, Mississippi, Alabama, Georgia and Florida lines; Group 6—Iowa, Illinois, Wisconsin and Minnesota lines; Group 7—Montana, Wyoming, Nebraska, North Dakota and South Dakota lines; Group 8—Kansas, Colorado, Missouri, Arkansas and Oklahoma lines; Group 9—Texas, Louisiana and New Mexico lines; Group 10—Washington, Oregon, Idaho, California, Nevada and Arizona lines; Group 11—Canadian lines.

9 (Texas, Louisiana and New Mexico). The increase in flat car surplus is in all groups, except 1 (as above), 8 (Kansas Colorado, Oklahoma, Missouri and Arkansas), and 9 (as above). The increase in coal car surplus is in groups 2, 3 (as above), 5 (Kentucky, Tennessee, Mississippi, Alabama, Georgia and Florida); 7 (Montana, Wyoming, Nebraska and the Dakotas), and 8 (as above). The increase in miscellaneous car surplus is in groups 3 (as above); 4 (the Virginias and Carolinas); 6, 9 (as above), and 10 (Washington, Oregon, Idaho, California, Nevada and Arizona).

The total shortage on July 15, 1913, was 6,875 cars; on June 30, 1913, 7,036 cars; and July 18, 1912, 6,467 cars.

Compared with the preceding period; there is a decrease in

**INTERSTATE COMMERCE COMMISSION.**

The commission has further suspended from July 23, until January 23, 1914, certain provisions contained in a supplement to Agent F. A. Leland tariff, which proposed to cancel through rates applicable in connection with Fourche River Valley & Indian Territory Railroad.

The commission has suspended from August 1 until October 29, the item in a supplement to the tariff of the Atchison, Topeka & Santa Fe, which contains an advanced rate for the transportation of flaxseed from St. Paul, Minn., and Minnesota Transfer, Minn., to Fredonia, Kan., the present rate being 15 cents per 100 lbs., and the proposed rate 26½ cents per 100 lbs.

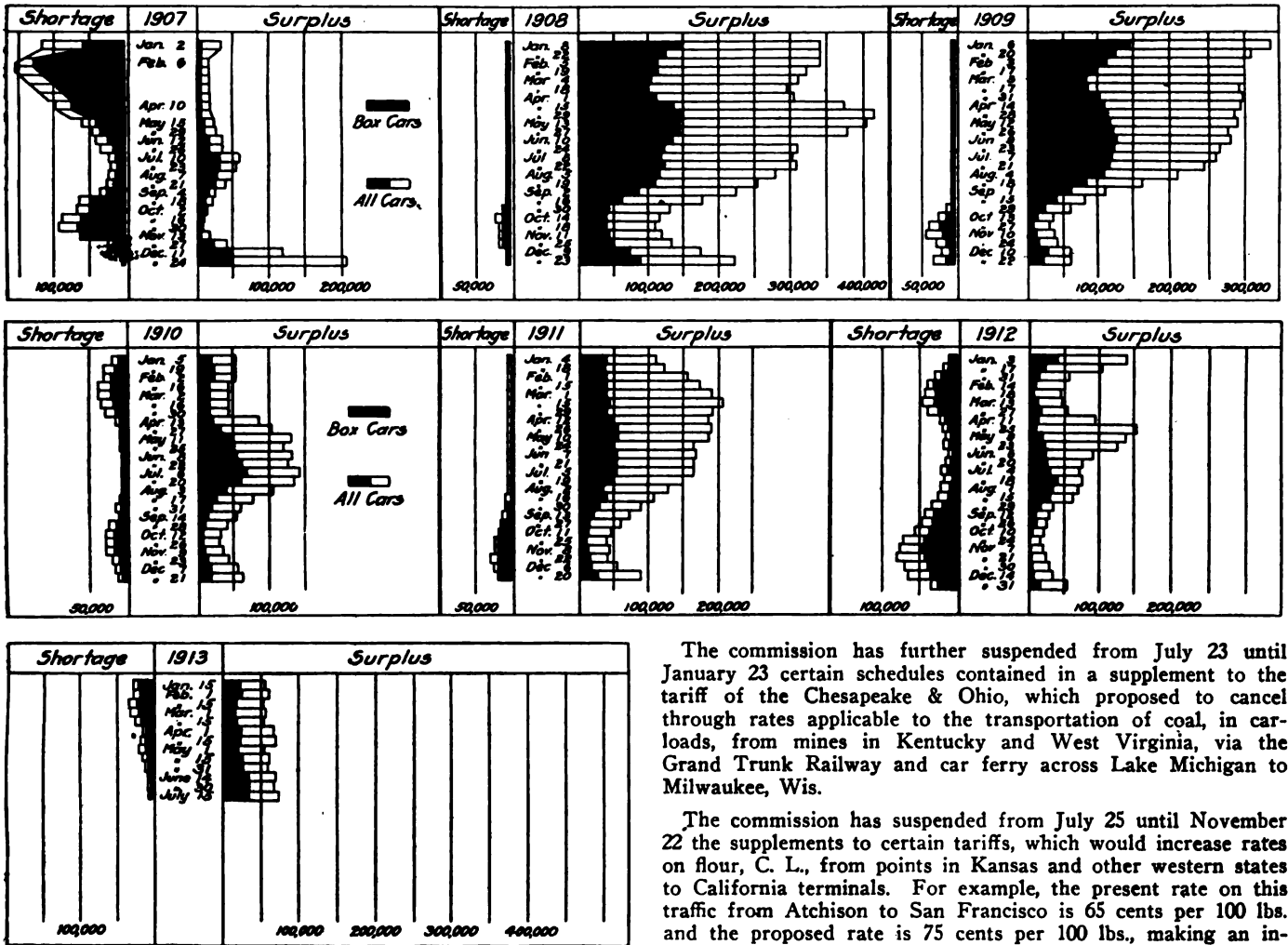

**Car Surpluses and Shortages, 1907 to 1913.**

the total shortage of 161 cars, made up as follows: an increase of 799 in box and 584 in miscellaneous, and a decrease of 549 in flat and 995 in coal car shortage. The increase in box car shortage is in groups 2, 5, 6, 7, 9 and 10 (as above). The increase in miscellaneous car shortage is in groups 1, 3, 7 and 10 (as above). The decrease in flat car shortage is in all groups, except 6 and 10 (as above). The decrease in coal car shortage is in all groups, except 9 and 10 (as above).

Compared with the same date of 1912; there is an increase in the total surplus of 891 cars, made up as follows: 2,718 in box and 1,064 in flat, and a decrease of 2,217 in coal and 674 in miscellaneous car surplus. There is an increase in the total shortage of 408 cars, made up as follows: 665 in box and 701 in miscellaneous, and a decrease of 710 in flat and 248 in coal car shortage.

The accompanying table gives car surplus and shortage figures by groups for the last period covered in the report and the diagram shows total by-weekly surpluses and shortages from 1907 to 1913.

The commission has further suspended from July 23 until January 23 certain schedules contained in a supplement to the tariff of the Chesapeake & Ohio, which proposed to cancel through rates applicable to the transportation of coal, in carloads, from mines in Kentucky and West Virginia, via the Grand Trunk Railway and car ferry across Lake Michigan to Milwaukee, Wis.

The commission has suspended from July 25 until November 22 the supplements to certain tariffs, which would increase rates on flour, C. L., from points in Kansas and other western states to California terminals. For example, the present rate on this traffic from Atchison to San Francisco is 65 cents per 100 lbs. and the proposed rate is 75 cents per 100 lbs., making an increase of 10 cents per 100 lbs.

The commission has suspended from July 31 until November 28, the tariff of the Chicago, Rock Island & Pacific, which proposed to advance rates for the transportation of wheat and grain products, c. l., from Oklahoma City and stations in Oklahoma west of that point to Memphis, Tenn. The amount of the advance proposed was 2½ cents per 100 lbs., the present rate, a group rate, being 20 cents per 100 lbs., and the proposed rate 22½ cents per 100 lbs.

**Complaint Dismissed.**

*Franke Grain Company v. Illinois Central et al. Opinion by the commission:*

The Minneapolis, St. Paul & Sault Ste. Marie Railway Company published on October 1, 1910, an index of tariffs, circulars, etc., showing Illinois Central tariff, I. C. C. A-5735, to be still in effect. The tariff had, however, been canceled December 8, 1907. On applying to the agent of such defendant in Milwaukee, the complainant was shown that company's circular above mentioned, and also the Illinois Central tariff, which showed rate of 14.75 cents per 100 lbs. from Oto and Onawa, Iowa, to Honey

Creek, Wis. Relying on the information thus obtained, complainant purchased and shipped one carload of corn from Oto and two from Onawa to Honey Creek on which rates of 21.75 cents and 20 cents, respectively, were applied. The commission decided that under the decisions of the United States Supreme Court in *Illinois Central v. Henderson Elevator Company*, 226 U. S., 441, and other cases cited, the complainant cannot recover damages on account of the failure of defendant to have the proper tariff posted at its stations; and that the record does not show that the rates charged were unreasonable.

#### Transcontinental Rates from Group F.

*In re investigation and suspension of advances in class and commodity rates between points in Iowa and Minnesota and points in Pacific territory. Opinion by Commissioner Harlan:*

In the tariffs under suspension the respondents have proposed to break up and rearrange one of the groups which the commission adopted as a basis for the rates prescribed in the Intermountain cases. Group F extends from Kansas City through Sioux City to Duluth, a distance of 693 miles. It is very long and very narrow. The respondents proposed to apply the Mississippi river rates to all points north of Sioux City to and including St. Paul and Minneapolis. This would put those points in group E. They also propose to apply the Chicago, or group D, basis to points north of the Twin Cities, to and including Duluth and Superior. This would leave group F undisturbed south of Sioux City. The change proposed would affect only the traffic moving to and from the South Pacific coast terminals, and to and from the southwestern intermountain territory; no change is proposed with respect to traffic to and from the North Pacific coast terminals. The commission decided that the proposed rates had been justified. There was no reason why Duluth should have better rates than Chicago to and from the territory in question, or why the Twin Cities should have better rates than the upper Mississippi river crossings. There is but little ground for a parity of rates to and from the southwest as between Kansas City and Duluth, which are at the two extremities of group F. The order of suspension will be vacated in respect of all of the rates except the rate on salt from Duluth to the South Pacific coast terminals. That rate was left unchanged. These findings will be subject to such modifications, if any, as may be required as the result of the action taken by the carriers in compliance with the views to be announced in *Iowa State Board of Railroad Commissioners v. A. E. R. R. Co.*, docket No. 5,241. (28 I. C. C., 1.)

#### Salt Rates Not Changed.

*Gottron Brothers Company v. Genesee & Wyoming et al. Bruce & West Manufacturing Company v. Erie Railroad et al. Morton Salt Company v. Buffalo, Rochester & Pittsburgh et al.*

*Sterling Salt Company v. Pennsylvania Railroad et al.*

*Opinion by Commissioner Harlan:*

The charges made in these complaints are that the carload rates on salt, when shipped in bulk, and when shipped in packages, are unreasonable in themselves; that the rates are discriminatory when compared with the rates from Detroit, Mich., and that the higher rates in salt in packages than on bulk movements of salt are unreasonable and unduly discriminatory. Violations of the fourth section are also alleged in the case of bulk shipment only. These alleged violations of the fourth section arise out of the existence of the special rate of 10 cents per 100 lbs. on bulk salt to Chicago, and the special rate of 7 to 8 cents per 100 lbs. on bulk salt to Detroit. The specific relief sought by the complainants is the reduction of the package rate to Chicago from 14 cents to the basis of the present rate of 10 cents per 100 lbs. on bulk salt, and the scaling of the latter rate on both bulk and package salt to other destinations, to which the rates from New York field are now scaled on the 14 cent rate to Chicago. As the rate of 10 cents per 100 lbs. on coarse salt in bulk from the New York field to Chicago was compelled by water competition, the commission decided that the normal rate of 14 cents per 100 lbs. between those points, when scaled back to intermediate points in accordance with the percentage basis, does not result in discriminatory rates or in rates that are unreasonable. The commission also found that any disturbance in the rate from Detroit with the idea of lining up the rates on

course salt from the respective mines, would disturb and throw out of line the rate on evaporated salt, which is shipped not only from Detroit but many other sections. If the rates from the New York field to particular destinations are unreasonable or discriminatory as compared with rates to the same points from Detroit, the adjustment may be rectified only by an increase in the Detroit rate, as a cut in the rate to those destinations from Retsof, N. Y., would break down the percentage adjustment on salt traffic. A higher rate on salt in bulk than on salt in packages was held to be neither unreasonable nor discriminatory when the differentials are not disproportionate to the difference in transportation conditions. The shipment of coarse salt in 200 lb. sacks is not entitled to the rate published for coarse salt in bulk, as it is well understood in the salt trade that the latter phrase applies only to salt shipped without containers. The tariff of one of the defendants named the 10 cent rate from Retsof to Chicago on (coarse salt) in carloads without limiting its application to such salt when shipped "in bulk." This rate was therefore applicable to carload movements of coarse salt in sacks or packages. When this was discovered the defendants made the necessary corrections. The commission decided that this increase was justified. The complaint was dismissed. (28 I. C. C., 38.)

#### STATE COMMISSIONS. 1197

The attorney-general of Arkansas has filed an intervention in the state rate litigation now pending in the federal court at Arkansas, asking that the state be awarded \$65,000 to reimburse it for its expense in carrying on the litigation involving the two cent fare and reduced state freight rates.

Engineers of the Illinois, Wisconsin and Michigan state railroad commissions have compiled a code of rules for the installation and operation of interlocking plants, which will be submitted to other commissions in an effort to have them adopted as uniform throughout the United States.

The Kansas Public Utilities Commission has given permission to the Kansas & Southwestern, a 60-mile road owned jointly by the Atchison, Topeka & Santa Fe and the St. Louis & San Francisco, to charge three-cents per mile passenger fares, on condition that \$70,000 is expended in improvements to the physical condition of the road. The order was issued on petition of communities along the line of the road.

The Illinois Railroad and Warehouse Commission is engaged on a general revision of the rules, specifications, descriptions of articles and minimum carload weights in the Illinois freight classification. The work is being done by Thomas L. Wolf, rate clerk for the commission, and the classification conference committee of the Illinois freight committee is co-operating with him. Thirty-five general rules have already been adopted, and an agreement has been reached with the railways and shippers on a large number of increases in carload minimum weights. This is the first general revision of the classification since 1906.

#### COURT NEWS.

A petition of the Minnesota state officials for an order directing the Chicago Great Western to put into effect for a test period of 90 days the new Minnesota passenger and freight rates, was denied by Judge Willard on July 28.

The right of any single state to regulate the power of an interstate corporation to raise funds for disbursement in various states is attacked by the Southern Pacific in a suit filed in the United States district court at San Francisco, asking an injunction to restrain the California Railroad Commission from asserting jurisdiction over a contemplated issue of equipment trust certificates to the amount of \$6,000,000.

A hearing on the application of eight railways in Iowa for an injunction restraining the state railroad commission from enforcing the rate of 1½ cents per mile for the Iowa state fair, prescribed by the last session of the legislature, was held before two judges of the United States court at Council Bluffs, on July 23. The case was taken under advisement. Representatives of the state argued that the reduced fare would increase the earnings of the roads by increasing the distance, and that

roads granted rates equally low to points outside of Iowa. The railroads attacked the law as unconstitutional and confiscatory.

The attorney-general of Texas has submitted a proposition to the Missouri, Kansas & Texas, looking to the compromise and dismissal of the suit of the state against that company for alleged violations of the anti-trust law. He stipulates that the railroads shall enter into an agreement with the state to connect its isolated line in East Texas with its main line near Waco, by building a distance of 100 miles, extending the Texas Central from Rotan to a connection with the Santa Fe at Fuller, 50 miles, and that all contracts between the Missouri, Kansas & Texas of Texas, and the Missouri, Kansas & Texas of Kansas shall be submitted to the Texas railroad commission for approval before they become effective.

The attorney general of the United States has brought suit in the district court at Portland, Ore., against the American Telephone & Telegraph Company and some of its subsidiaries, claiming that these companies have violated the provisions of the Sherman law in creating a monopoly in Oregon, Washington, Montana and Idaho. It was announced by the department of justice that this proceeding was brought to correct an exceptional condition and would not in any way interfere with the broad investigation of telephone conditions throughout the entire country undertaken by the Interstate Commerce Commission at the suggestion of the former attorney general. Theodore N. Vail, president of the American Telephone & Telegraph Company, gave out a statement in which he said that the facts in the case would not be contended, but that his company relied upon being able to show that the facts as presented by the government did not constitute a violation of the anti-trust law.

**CANTON-HANKOW RAILWAY, CHINA.**—The associate director of the Canton-Hankow and Hankow-Szechuan railways, Dr. Jeme Tien-yew, arrived at Hankow early in May to arrange for the commencement of construction work. He stated that money was available for the construction of the British section, and that he expected work to begin immediately. The first work to be undertaken will be to complete the purchase of the land, then to make the earthwork. The only material that has been ordered up to the present is the telegraphic material.

**NEW RAILROADS IN CUBA.**—A railroad is projected from Placetas to Trinidad, Santa Clara province. Trinidad is one of the oldest towns of Cuba and one of the most picturesque. It is, however, entirely cut off from railroads and has thus lost much of its importance. A railroad from Caibarien to Mayajigua, in Santa Clara province, is about ready for service. The Narciso Sugar Central is largely interested in the road, which will permit direct transportation of its sugar to Caibarien on the north coast. A \$300,000 railway from the Socorro sugar mill, in Matanzas province, to Playa Liza, in the Cienega de Zapata, is planned by Sr. Pepro Arenal, owner of the mill.

**CHILEAN RAILWAYS.**—The competition which was threatened for the Antofogasta Railway when the Arica-La Paz was completed has hitherto had no appreciable effect upon the business carried on by the admirably conducted and efficiently equipped line which serves the sister states of Chili and Bolivia. For some years past the receipts derived from all sources have shown a consistent expansion; for the past twelve months they have been particularly good. The future seems even more rosy yet, for several fresh channels of usefulness have been opened, such as a revival in the tin-mining industry, and the improvement in the copper-mining operations of Chili. It is true that working expenses have marked an unpleasant advance, comparing, in this respect, very adversely with those of the previous years, and especially with those of 1911. This is not at all difficult, however, to understand. Firstly, passenger traffic has considerably augmented; secondly, the roadbed has called for a large amount of exceptional outlay; while, thirdly, coal has increased very much in price, and will probably advance still further. The fuel bill alone accounts for about 14 per cent. of the working expenses of this railway. The directors, it is understood, are in favor of introducing oil-fuel to a large extent, but before the local management can endorse this policy it will be desirable to continue for some time yet the experiments which have been in hand for the last 12 months.

## Railway Officers.

### Executive, Financial and Legal Officers.

W. C. Chisholm, K.C., has been appointed general solicitor of the Grand Trunk, with headquarters at Montreal, Que. W. E. Foster has been appointed solicitor and will take charge of such matters arising in the province of Ontario as may be assigned to him.

J. Nicholson has been appointed auditor of disbursements of the Galveston, Harrisburg & San Antonio, Houston & Texas Central, Houston East & West Texas, Houston & Shreveport and the Texas & New Orleans, with headquarters at Houston, Tex.; effective August 1.

### Operating Officers.

S. L. Kamps has been appointed inspector of transportation of the Chicago Great Western, with office at Chicago.

M. Dailey has been appointed general manager of the Muscatine North & South Railway, with headquarters at Muscatine, Iowa, in place of H. B. Holbert, resigned.

The headquarters of W. T. Tyler, general manager of the St. Louis & San Francisco, have been removed from Springfield, Mo., to St. Louis; effective August 1.

Richard L. Barrett has been appointed trainmaster of the Pittsburg, Shawmut & Northern, with office at St. Mary's Junction, Pa., succeeding J. T. Colbert, promoted.

T. J. Hayes, trainmaster of the Cleveland, Cincinnati, Chicago & St. Louis at Cleveland, Ohio, has been appointed superintendent of terminals at Cincinnati, Ohio. P. T. White, trainmaster at Springfield, Ohio, succeeds Mr. Hayes, and O. C. Wyman, trainmaster at Wabash, Ind., takes the place of Mr. White.

George H. Schleyer, one of the receivers of the St. Louis, San Francisco & Texas and the Ft. Worth & Rio Grande, assumes the title of general manager in addition to his duties as receiver, with headquarters at Ft. Worth, Tex. W. E. Livingston, trainmaster of those roads, is appointed superintendent and G. A. Chandler, car accountant, is appointed superintendent of car service, both with headquarters at Ft. Worth, and the offices heretofore held by them are abolished. Effective July 21.

C. O. Jenks, who recently was made general superintendent of the Lake district of the Great Northern, with headquarters at Superior, Wis., as already announced in these columns, was born March 6, 1874, at St. Paul, Minn. He was educated at the University of North Dakota, and began railway work in June, 1891, as clerk in the superintendent's office of the Great Northern. He was successively chief clerk, trainmaster, assistant superintendent and superintendent of various divisions until October, 1906, when he became president and manager of the Nelson-Jenks Company of Great Falls, Mont. In December, 1909, Mr. Jenks returned to active railway service as superintendent of the Butte division of the Great Northern. He was promoted to general superintendent of the Central district in March, 1912, which position he held until he was appointed general superintendent of the Lake district on July 20, as above noted.

Alfred Price, whose appointment as assistant general manager of the Canadian Pacific, with headquarters at Montreal, Que., has been announced in these columns, was born on December 6, 1861, at Toronto, Ont., and was educated in the public schools of his native town. He began railway work in September, 1879, and was consecutively operator, messenger and clerk, and car accountant on the Credit Valley Railway until 1882, and was then operator and relief despatcher of its successor, the Canadian Pacific, at Toronto, since which time he has been in the continuous service of that road. From 1884 to July, 1888, he was train despatcher at the same place, and was then car distributor until May, 1896, when he became car distributor and chief despatcher. In August, 1898, he was appointed superintendent at Toronto, and in May, 1903, was transferred in the same capacity to Fort William, Ont. He was appointed superintendent of transportation, western lines, in August, 1904, at Winnipeg, Man., and in March, 1907, was promoted to general superintendent.



ent of the Central division at the same place. On December 1, 1907, he was made general superintendent of the Alberta division with headquarters at Calgary, Alta., which position he held at the time of his recent appointment as assistant general manager of the same road, with headquarters at Montreal, as above noted.

H. A. Worcester, whose appointment as general manager of the Cleveland, Cincinnati, Chicago & St. Louis, with headquarters at Cincinnati, Ohio, has already been announced in these columns, was born November 18, 1862, at Albany, N. Y. He is a graduate of Yale University, and began railway work in December, 1885, with the New York Central & Hudson River as assistant stationmaster at the Grand Central station in New York City. In August, 1891, he entered the service of the Lake Shore & Michigan Southern at Buffalo, N. Y., as clerk, and one year later he was made assistant trainmaster of the Franklin division, from which position he was advanced to superintendent of the Lansing division in February, 1893. In June, 1896, Mr. Worcester was transferred to the superintendency of the Detroit division, where he remained until November, 1902, when he was made superintendent of the Eastern division, and in February, 1905, he was placed in charge of the Western division for three months as superintendent. He then went to the Michigan Central in April of that year as assistant general superintendent and was promoted to general superintendent in November. He returned to the Lake Shore in February, 1906, as general superintendent and the following October was made assistant general manager of the Cleveland, Cincinnati, Chicago & St. Louis, which position he held at the time of his recent appointment as general manager, as above noted.



H. A. Worcester.

#### Traffic Officers.

D. M. Middleton has been appointed commercial agent of the Lehigh Valley, with headquarters at New York.

Leslie Rawls has been appointed special representative of the traffic department of the Western Maryland, with office in Baltimore, Md.

The headquarters of C. Hanson, joint general livestock agent of the International & Great Northern and the Texas & Pacific, have been moved from Ft. Worth, Tex., to San Antonio.

William A. Wallace has been appointed traveling freight agent of the Erie, with office at Reading, Pa. Ira S. Auch has been appointed general agent with office in Philadelphia, Pa., succeeding Mr. Wallace.

W. C. Preston, general freight and passenger agent of the St. Louis, San Francisco & Texas and the Ft. Worth & Rio Grande, is appointed traffic manager, with headquarters at Ft. Worth, Tex., and the former office is abolished; effective July 21.

Albert Davidson has been appointed general agent of the Grand Trunk Pacific and the Grand Trunk in charge of passenger and freight traffic in western British Columbia, north of Rivers Inlet, including Queen Charlotte islands, succeeding A. E. McMaster.

Howard C. Montague has been appointed commercial agent of the Georgia Southern & Florida, with office at Chattanooga, Tenn., succeeding James F. Slowey, resigned. Harold L. Peters has been appointed soliciting freight agent at Tampa, Fla., effective August 1, succeeding Mr. Montague.

C. H. Todd, general agent of the Western Maryland at Indianapolis, Ind., has been appointed traveling freight and passenger agent, with headquarters at Elkins, W. Va., and H. E. Williams has been appointed general agent, with office at Baltimore, Md., succeeding C. H. Porter, assigned to other duties. Effective August 1.

Fred R. Porter has been appointed general freight agent of the Grand Trunk Pacific, with office at Winnipeg, Man., succeeding R. J. Foreman, who has accepted service with the Grand Trunk Railway. F. G. Adams has been made division freight agent at Edmonton, Alta., succeeding Mr. Porter. A. E. McMaster has been made commercial agent at Regina, Sask., succeeding Mr. Adams.

W. J. Frost, traveling passenger agent of the Missouri Pacific at Cincinnati, O., has been transferred to Indianapolis, Ind., in a similar capacity, in place of C. D. Boyd, resigned to engage in other business. Lee B. Scheurer, city passenger agent at Cincinnati, succeeds Mr. Frost. G. M. Trickett has been appointed traveling passenger agent, with office at Little Rock, Ark., in place of W. H. Glover, who has been transferred to Chicago as traveling passenger agent in place of I. M. Keller, resigned to enter other business.

Edward M. Kain, whose appointment as assistant general freight agent of the Erie, with office at Buffalo, N. Y., has been mentioned in these columns, was born on August 16, 1866, at Elmira, N. Y. Mr. Kain began railway work in 1884 in the service of the Erie, and has been with that company ever since. He was stationed at various places, including Binghamton, N. Y. On January 12, 1905, he was made division freight agent at Elmira, which position he held until July 15, 1913, when he was made assistant general freight agent as mentioned above.

Arthur Campbell Shaw, whose appointment as general passenger agent of the Canadian Pacific, with office at Winnipeg, Man., has been mentioned in these columns, was born at Detroit, Mich., May 12, 1865. He was educated at the Normal school, Toronto. He entered railway service in 1880 with the Great Western Railway of Canada. From 1882 to 1886 he was engaged in other business, but on March 13, 1886, he again took up railway work in the office of the district passenger agent of the Canadian Pacific, at Toronto. On December 1, 1886, he was transferred to the office of the general passenger agent at Montreal, Que. On December 1, 1900, he was transferred to the office of the general agent of the passenger department at Chicago. On November 1, 1910, he was made assistant general passenger agent, with office in Winnipeg, which position he retained until July 1, 1913, when he was made general passenger agent as mentioned above.

#### Engineering and Rolling Stock Officers.

W. T. Leyden, master mechanic of the Minneapolis & St. Louis, with headquarters at Marshalltown, Iowa, has resigned.

W. C. Groening has been appointed master mechanic of the Pere Marquette, with office at Wyoming, Mich., succeeding J. E. Hickey, resigned.

J. J. Daily has been appointed roadmaster of the first district of the Oregon Short Line, with headquarters at Kemmerer, Wyo., in place of John McGreevey, resigned.

J. C. Mill, assistant signal engineer of the Chicago, Milwaukee & St. Paul, has been appointed signal engineer, with office at Milwaukee, Wis., succeeding A. Brown, deceased; effective August 1.

George Thomson, division general foreman in the car department of the Lake Shore & Michigan Southern at Englewood, Ill., has been appointed assistant master car builder, Michigan Southern division of that road, also of the Chicago, Indiana & Southern and the Indiana Harbor Belt, with headquarters at Englewood.

Charles Edward Smith, whose appointment as assistant chief engineer of the Missouri Pacific, with headquarters at St. Louis, Mo., has already been announced in these columns, was born August 20, 1877, at Somerville, Mass. He was educated at the Massachusetts Institute of Technology, and began railway work in June, 1897, as rodman on the New England Railroad at Boston, Mass. From June, 1898, to September, 1899, and from June to November, 1900, he was assistant city engi-

neer at Putnam and Willimantic, Conn. Later until September, 1903, he was draftsman and bridge designer for the New York, New Haven & Hartford at New Haven, Conn. The following six months he was with the Bureau of Yards and Docks of the Navy Department at Washington, D. C., as steel draftsman. Mr. Smith returned to railway service in March, 1904, as assistant bridge engineer on erection and inspection work for the Lake Shore & Michigan Southern at Cleveland, Ohio. In March, 1905, he went to the International Correspondence Schools as text book writer, leaving in December of the following year to become technical editor, structural materials division, U. S. Geological Survey. He entered the service of the Missouri Pacific in August, 1907, as assistant engineer on general work in the maintenance of way department at St. Louis, Mo. On September 1, 1909, he was made bridge engineer, which position he held at the time of his promotion to assistant chief engineer, as above noted.

#### Purchasing Officers.

Samuel Porcher, assistant purchasing agent of the Pennsylvania Railroad, with office in Philadelphia, Pa., has been appointed purchasing agent, with office in Philadelphia, succeeding Daniel S. Newhall, deceased.

#### OBITUARY.

Anthony N. Brady, chairman of the board of directors of the Brooklyn Rapid Transit Company, died in London, England, on July 22, at the age of 71. The directors of the Brooklyn Rapid Transit Company adopted a resolution relating to his death, which is in part as follows: "For seventeen years he has been actively concerned in the direction of the company's business. During all of that period he has shown unceasing interest in its growth and development, manifesting that interest not only in the devotion of service and talents to its affairs, but in his large investments in its securities. Never for an instant has his faith in its success or his loyalty to its welfare wavered."

Arthur S. Hanson, general passenger agent of the Boston & Albany, with office in Boston, died on July 28, at the age of 61. Mr. Hanson was born in Salem, Mass., December 31, 1851. After studying at St. Mark's school, at Southboro, Mass., he spent three years in Boston in the mercantile business. In 1872 he went to Chicago and entered railway work in the service of the Illinois Central. On December 1, 1878, he entered the passenger department of the Boston & Albany, with which company he has been continuously associated ever since. He was appointed assistant general passenger agent on February 1, 1882, and general passenger agent on December 1, 1884, which position he held at the time of his death.

Edward A. Taft, manager of the express department of the New York, New Haven & Hartford, died on July 29 at his home in Boston. Mr. Taft was born in 1845, and served as captain's clerk on the gunboat *Cambridge* and the sloop of war *Tuscarora* in the civil war. He began as clerk with the Merchants' Union Express Company in 1866, and was later made auditor of the New England Express Company, and in 1886 was made a member of the board of managers of the Erie Express, which later was merged with Wells, Fargo & Company. He later became a director and president of the rector and chairman of the board of the Manhattan Delivery Morris European & American Express Company, and a di-Company.

**THE CHEFOO-WEIHSIEN RAILWAY, CHINA.**—The surveying corps have finished the surveying of the line from Chefoo to Weihsien, a distance of 200 miles.

**PRIZES FOR NEAT HOMES IN VICTORIA.**—In addition to other prizes awarded to the Victorian Railway employees, it was decided some time ago to award prizes to the workmen for neat homes. The competition was arranged so as to encourage workmen in the habit of keeping hygienic homes and improving them by laying out gardens, planting trees, etc. On the Victorian railways three prizes are given annually in each of the seven districts in the state, as follows: \$30 for the first; \$15 for the second, and \$5 for the third.

## Equipment and Supplies.

### LOCOMOTIVE BUILDING.

**THE MONONGAHELA** has ordered 6 consolidation locomotives from the American Locomotive Company. The dimensions of the cylinders will be 21 in. x 30 in., the diameter of the driving wheels will be 51 in. and the total weight in working order will be 194,000 lbs.

### CAR BUILDING.

**THE ATLANTIC COAST LINE** is in the market for 25 phosphate cars.

**THE NEW YORK CENTRAL LINES** are in the market for about 300 passenger cars.

**THE CHICAGO, BURLINGTON & QUINCY** is in the market for 15 combination baggage and mail cars and 10 mail cars.

### IRON AND STEEL.

**GENERAL CONDITIONS IN STEEL.**—There has been a marked improvement in the buying movement during the past week. This is largely due to the greater confidence that is felt in the crop prospects. Consumers are now entering the market and are placing large orders for new business which had been held in abeyance for some time. The improvement has compensated partially for the sharp falling off in business and in production early in July. Prices are firm and the mills are operating at about 90 per cent. of their capacity. There are enough orders on the books to keep the mills running at this capacity for three or four months.

**FORESTRY IN FRANCE.**—France has spent \$35,000,000 in planting trees on the watersheds of important streams.

**SOUTH AUSTRALIAN RAILWAYS.**—Railways were early in starting in South Australia, the first one, between Adelaide and Port Adelaide, being opened in 1856, with the Victorian gage of 5 ft. 3 in., which was continued on the main lines connecting with Victoria.

**REPORTING FOREST FIRES.**—The Western Pacific has instructed its engineers to report fires along the right-of-way where it traverses the Plumas national forest in California. The location of fires is indicated on a card dropped by the engineer or fireman to the next section crew met after the fire is discovered. It is then the duty of part of the section crew to go back on hand-cars or speeders and put out the blaze.

**STEAM FOR CAR NAVIGATION.**—Benjamin Phillips, architect, of Philadelphia, proposes to construct a steam car to travel on rivers at a speed of 20 to 25 miles per hour to carry one hundred passengers, to draw 15 in. of water, to be only one-third the weight of any other ordinary steamboat of the same dimensions now afloat; of far superior strength and safety, constructed on entirely new principles; the whole material except the engine and boiler to cost about \$1,600 completely furnished and ready for operation by the first day of May next.—*From the American Railroad Journal for January, 1833.*

**EARLY RAILROAD TRAVEL.**—We are requested to state that there has not been a day since the opening of the Camden & Amboy Railroad that the Philadelphia and New York passengers have not been taken over the road each way with the exception of Saturday and Monday last, notwithstanding the recent heavy falls of snow. On those days there were no passengers from Philadelphia, owing to the company's not being able to procure coaches to convey passengers from Philadelphia to the railroad. The passengers that left New York on the above-mentioned days were taken over the railroad in cars and forwarded to Philadelphia the same evening in sleighs. The stage arrangements being now completed, passengers will be conveyed from the railroad to Philadelphia in coaches until the river Delaware opens.—*From the American Railroad Journal, March 9, 1833.*

## Supply Trade News.

F. E. Hutchison, who recently resigned as chief electrician of the Chicago, Rock Island & Pacific, was appointed at that times sales manager of the Moon Manufacturing Company, of Chicago.

The National Tube Company, Pittsburgh, Pa., has contracted with the National Metal Molding Company and the Safety-Armorite Conduit Company, both of Pittsburgh, to manufacture and sell electrical conduit for it as its agents, under their various brands.

Eighteen minority stockholders of the Union Car & Equipment Company, Chicago, have applied to the United States Circuit Court at Chicago for the appointment of a receiver for the company, alleging that the company's affairs are involved and that it has ceased to do business.

Harrison G. Thompson, manager of the railway department of the Edison Storage Battery Company, Orange, N. J., has been made a vice-president of that company. Mr. Thompson was born in Weston, Mass., in 1875. His railroad experience began with the Pullman Company in 1896. When he had been with that company for two years he was made foreman of electricians. In 1900 he resigned to become foreman of the battery department of the Riker Motor Vehicle Company. Leaving this concern at the time of its absorption by the General Vehicle Company of Hartford, Conn., Mr. Thompson became associated with W. L. Bliss, one of the pioneers in electric car lighting development. He resigned from the Bliss Company in 1905 and went to the



H. G. Thompson.

Pennsylvania Railroad where he was in charge of electric car lighting with headquarters at Jersey City, N. J. In 1906 he went to the Safety Car Heating & Lighting Company, New York, as electrical superintendent. He was in charge of this company's electrical laboratories during the development of its first electric car lighting system. In December, 1909, he was appointed manager of the railroad department of the Westinghouse Storage Battery Company. He was later with the United States Light & Heating Company, New York, for a short time. On July 1, 1910, he was made manager of the railway department of the Edison Storage Battery Company, which position he held until his appointment as a vice-president as mentioned above. He is a member of the executive committee of the Telephone and Telegraph Appliance Association, and for three years was vice-president of the Association of Railway Electrical Engineers.

Ground was broken on July 23, for the new plant of the Baldwin Locomotive Works in East Chicago. The plant is to be built in several units, the first unit to occupy a building 1,400 x 600 ft. of concrete and steel. The H. A. Strauss Company, of Chicago, has the contract for the construction of the concrete work on the first unit.

W. F. Girtten, representative of the railroad department of the Garlock Packing Company in Eastern territory, and formerly general storekeeper of the Central of New Jersey and of the Delaware, Lackawanna & Western, died at the Presbyterian Hospital, Newark, N. J., on July 27, of a complication of intestinal and stomach troubles. The funeral was held on Tuesday.

On Monday, July 28, the General Electric Company had on exhibition at Schenectady, N. Y., the control apparatus for the Gatun lock of the Panama canal. It was assembled just as it will be when it is finally placed in operation, and demonstra-

tions of its workings were made before a number of guests, including engineers, members of the technical press and General Electric employees. Details of this apparatus, which has many points of similarity with the interlocking apparatus used on railroads, will be published later.

The B. F. Sturtevant Company of Canada, Ltd., has recently been incorporated in Canada and will build a plant at Galt, Ontario. From this plant the company will handle all business in Canada and also export to England, Australia and other foreign countries. Arrangements have been made to provide for an expansion of this plant up to ten acres. Salesmen are already located to cover the Montreal, Toronto and Vancouver sections and offices will soon be established in each principal city in Canada. This company will make and sell some of the more important lines of apparatus now handled by the B. F. Sturtevant Company, Hyde Park, Mass., including fans and blowers, planing mill exhausters, propeller fans heating and ventilating apparatus, fuel economizers, steam turbines, vertical engines, generating sets and stokers.

Manning, Maxwell & Moore, Inc., New York, together with its subsidiary companies, will move its general offices on or about October 1 from 85-89 Liberty street to the new Lewisohn building, 113-119 West Fortieth street. This change is being made to meet the demand for a more convenient and central location, as well as larger space to handle material increases in their various lines, which cover electric traveling cranes, machine tools, engineering specialties and railway, machinists', engineers', factory and contractors' supplies. A large portion of this product is manufactured by their constituent companies, the Shaw Electric Crane Company, the Ashcroft Manufacturing Company, the Consolidated Safety Valve Company, the Hayden & Derby Manufacturing Company, and the Hancock Inspirator Company. The amount of floor space in the new offices will be 28,000 sq. ft., almost double that of the present offices.

### TRADE PUBLICATIONS.

**WATER SOFTENERS.**—The Kennicott Company, Chicago Heights, Ill., is distributing a pamphlet describing the company and its work by Elbert Hubbard.

**DENVER & RIO GRANDE.**—The passenger department has issued a 98-page booklet describing the attractions of outdoor life in the Rocky mountains, including descriptions of the various places and valuable suggestions for people contemplating an outdoor vacation, with estimates of the various incidental expenses.

**TITANIUM ALLOY FOR OPEN HEARTH RAILS.**—The Titanium Alloy Manufacturing Company, Niagara Falls, N. Y., has prepared bulletin No. 1 of a series of rail reports which will be published from time to time, giving the results of a series of studies of rail steels both in service and in the laboratory. The present bulletin covers tests made on five sets of samples of standard open hearth and titanium treated "A" rails which were rolled by the same mills under the same specifications, the only difference being the introduction in one set of 0.1 per cent. of titanium alloy. The report of these tests includes a set of 10 sulphur prints showing segregation of the carbon, phosphorus and sulphur and a set of 16 photomicrographs showing the characteristic structure of the steel in the two sets of rails. The specimens from which some of these photomicrographs were made were etched by different treatments to show the arrangement of ferrite, cementite and pearlite. These photographs also show, of course, the phosphorus enclosures and slag fissures. The report also contains the results of mechanical analyses and physical tests of both sets of rails with a brief description of the method of taking the sample pieces and making some of the tests and a short discussion of the showing made by the treated rails. The conclusions reached in the report are that the treated rail is more ductile than standard open hearth steel without being lower in strength, that it is slightly harder, more resistant to impact, less easily broken and is superior in endurance under normal loads. The treated steel is practically homogeneous, resulting in improvement of all the physical properties, as shown by the comparative tests. The manner of presenting information which is followed in this report is highly commendable, as the best known methods of testing are employed and the company offers any railroad or steel mill official free access to the original records of the tests which are on file in its laboratory to make further investigation or verify any of the statements made.

## Railway Construction.

**AUGUSTA & EDGEFIELD (Electric).**—We are told that this company plans to build from Augusta, Ga., north via North Augusta, S. C., Ropers, Edgefield, Pleasant Lane and Kirksey, to Greenwood, 55 miles, with permission to use either steam or electricity for the motive power. C. W. Requarth, Charlotte, N. C., will have charge of the survey and obtaining rights of way. It is expected that the survey will be completed this fall, when contracts for grading, track laying, bridges, etc., will be let. There will be two bridges, one over the Savannah river at Augusta, Ga., and one over Turkey creek; also terminal stations, way stations and a power plant. The principal commodities to be carried are cotton, grain, merchandise and lumber. The line will traverse a thickly settled but undeveloped farming and timber section. William P. Calhoun, chairman of the survey committee, Edgefield.

**BUTTE, BOISE & WINNEMUCCA.**—According to press reports construction work has started on the line of this company from Boise, northeast to Butte, to a connection with the Gilmore & Pittsburg, and from Boise southwest to Winnemucca, Nev., to a connection with the Western Pacific. The contract was awarded to J. W. Monarch.

**CALIFORNIA-OREGON & EASTERN.**—This company is planning to build from Grants Pass, Oregon, southwest to Crescent City, Cal., about 100 miles. William Loftus, Portland, Oregon, is president of a construction company that has been organized to build the line. The grading work is to be started at once on the first section of 10 miles from Grants Pass to Wilderville, crossing the Rogue and Applegate rivers. Franklin Helm, San Francisco, Cal., represents California capitalists backing the project. (See Grants Pass-Crescent City, April 11, p. 863.)

**CANADIAN PACIFIC.**—This company will build an electric line from Hamilton, Ont., to Niagara Falls. By constructing this electric line through the Niagara peninsula, the Canadian Pacific will be in a position to handle traffic direct from Hamilton to Buffalo on its own right of way, instead of operating, as at present, over the lines of the Toronto, Hamilton & Buffalo and the Michigan Central. The Canadian Pacific may undertake, also, the construction of a line from Toronto to Hamilton, to avoid operating over the Grand Trunk tracks.

**CHARLOTTESVILLE INTERURBAN.**—We are told that surveys have been made and the route decided upon, for a line from Charlottesville, Va., southwest about 15 miles to Alberene. Financial arrangements are not yet complete, but it is probable that the line will be built. Walter Washabaugh, Charlottesville, may be addressed.

**COLORADO, KANSAS & OKLAHOMA.**—An officer writes that this company intends to build from Scott City, Kan., to a connection with the Midland Valley at Wichita. The route has not yet been definitely decided upon, but the line will probably run from Scott City to Dodge City, thence to Kinsley and thence to Wichita. Preliminary surveys will be made shortly. The incorporators are Frank S. Yantis, managing receiver of the Scott City Northern, Scott City; W. C. Fordyce, E. F. Goltra, W. V. Delahunt, all of St. Louis; all officers of the Scott City Northern; Leo Monroe and C. M. Monroe, of Scott City, and James A. McClure, of Topeka, Kan.

**DIXIE RAILWAY.**—An officer writes that work is now under way building from Alexander City, Ala., south to Benson, 15 miles. O. J. Pruett is the contractor. Grading has been finished on seven miles, and track laying has recently been started. The work involves handling about 10,000 cu. yds. a mile. There will be one 500-ft. trestle on the line. The company expects to develop a traffic in lumber, naval stores and cotton oil products. W. E. Benson, president, and D. B. McKenzie, chief engineer, Benson. (June 13, p. 1324.)

**FOX & ILLINOIS UNION (Electric).**—An officer writes that the track is all laid from Yorkville, Ill., south to Morris, about 20 miles. H. H. Evans is president, with office at Aurora, Ill. F. M. Zimmerman is chief engineer.

**GREAT NORTHERN.**—See Kettle Valley.

**KETTLE VALLEY.**—According to press reports, this company, jointly with the Great Northern, will build the unfinished link across the Hope mountains from the Coquehalla summit to Hope, B. C., on the Frazer river, 60 miles. Bids will be called for immediately. The Kettle Valley will build and operate the section, both systems sharing the expense and running rights.

**MATADOR & NORTHERN (Electric).**—An officer writes that a contract has been given to F. Fennon, and work is now under way from a connection with the Quanah, Acme & Pacific at a point three miles east of Roaring Springs, Tex., to Matador, 9 miles, and grading work is about 25 per cent. completed. The maximum grade is 1 per cent., and maximum curvature 4 deg. There will be five trestles on the line. A. B. Echols is president, and G. A. Lider, chief engineer, Matador.

**MINNEAPOLIS, ST. PAUL, ROCHESTER & DUBUQUE TRACTION.**—An officer writes that a contract for grading work on eight miles has been given to Frederick & Barnard, Minneapolis, Minn., and sub-contracts have been given to Dale & Baumgardner, St. Paul, and to McCollough & Cheney, Minneapolis. The company now operates an electric line from Minneapolis, Minn., south, and plans to build an extension southwest via Rochester and Cresco, Iowa, towards Dubuque.

**MISSOURI, KANSAS & TEXAS.**—This company is planning to build from Whitney, Tex., to Hillsboro, on the main line, to make traffic arrangements with the Trinity & Brazos Valley from Hillsboro to Teague, to build about 65 miles from Teague to Trinity, connecting there with the branch to Livingston and to build from Livingston to Galveston via Beaumont. This will give the company a much more direct route to Galveston.

**NORTHERN PACIFIC.**—This company is planning to start work shortly on the Lake basin branch, which will run from Great Northern Junction, Mont., on the main line, north to Hester on the Billings & Northern, thence northwesterly past Stickley to a point north of Busteed, and east of Gibson.

**PINE BLUFF & NORTHERN.**—An officer of this company, which operates 8 miles of railway from McCreanor, Ark., on the Chicago, Rock Island & Pacific, south to Cullor, writes that the work is held up pending a decision of the Supreme Court of Arkansas regarding the construction of a bridge over the Arkansas river. The company started work some time ago from McCreanor south to Pine Bluff, 42 miles, and expects to develop a traffic in lumber and timber products, cotton and farm products, rice and merchandise.

**SOUTHERN NEW ENGLAND.**—Contractor John Marsch, who had been doing the work on this line from Palmer, Mass., to Providence, R. I., has been asked to complete his contract. The section between Palmer and Blackstone, 58 miles, will be built first, as the construction of that section would take about 18 months. Construction work will not be resumed in Rhode Island until the Massachusetts section is well under way. It is understood that Mr. Marsch is ready to resume work upon a guarantee of reimbursement for such damages as he suffered on account of the previous interruption.

**VAN HORN VALLEY.**—Organized in Texas, with headquarters at Van Horn, to build from Lobo, Tex., on the Southern Pacific to a connection with either the El Paso & Southwestern or the Atchison, Topeka & Santa Fe at some point in New Mexico, over 200 miles. The incorporators include R. H. Owen, F. J. Cumming, J. E. Hayes and A. M. Lewis, all of Minneapolis, Minn.; J. Y. Canon and J. M. Daugherty, Van Horn; J. McGregor, Lobo.

**WABASH.**—This company has just completed and put into service a set of new double tracks between Bement, Ill., and Monticello, 10 miles. This road will soon have double track from St. Louis to Lodge, 150 miles, on the line to Chicago. The second track being built from St. Louis to the Indiana State line, 200 miles, is also near completion.

**WESTERN MARYLAND.**—Construction work will be begun at once on a branch from a point near Henry, W. Va., to Kempton, about 3 miles. This branch will be known as the Kempton branch, and will serve a new coal mine of the Davis Coal & Coke Company. The contract for the construction of the line has been awarded to A. L. Anderson & Brothers, Altoona, Pa.

## RAILWAY STRUCTURES.

**ASHTABULA, OHIO.**—The Lake Shore & Michigan Southern will open bids next week for the car shop which is to be built at this point. The shop will be 200 ft. x 450 ft. and will cost about \$40,000.

**BROWNWOOD, TEX.**—The Gulf, Colorado & Santa Fe has let contracts to H. D. McCoy, of Cleburne, for a 12-stall brick and concrete roundhouse, a machine shop 60 x 80 ft., and a power house 37 by 80 ft.

**CUMBERLAND, MD.**—The Western Maryland has completed the construction of a roundhouse, a power plant, a machine shop and engine terminals at Maryland Junction, near Cumberland. The roundhouse has 20 stalls and is of steel and concrete construction. The contract for furnishing the structural steel for this building was awarded to the McClintic-Marshall Construction Company. The machine shop is equipped for light repairs to engines and cars but particularly to engines. The engine terminals will be of sufficient size to meet the needs of the company at that point. These improvements are a part of the general terminal development at Cumberland. A new passenger and freight station has recently been completed at that point by this road.

**DENVER, COLO.**—Plans have been prepared by the engineers for the proposed remodeling of the Denver union station, together with track elevation and improvements, which will bring the cost up to about \$2,000,000.

**DURANÍ, OKLAHOMA.**—A new Union station will be built at this point by the Missouri, Kansas & Texas, the St. Louis & San Francisco and the Missouri, Oklahoma & Gulf jointly. It will cost about \$60,000.

**MEXIA, TEX.**—The Houston & Texas Central has purchased a tract of 260 acres near Mexia, on which will be erected a 12-stall roundhouse, car sheds and shops to handle running repairs. Plans for the improvement are now being prepared by the engineering department.

**PADUCAH, KENTUCKY.**—The Illinois Central will double the capacity of its shops at this point. Details are not yet available, but new buildings will be erected and new machinery installed.

**ROCHESTER, N. Y.**—The New York Central & Hudson River is building four bridges at Rochester over Hudson, Chatham, Joseph and Clinton street or avenues. These bridges will have solid floors and the subways will be of steel. About 2,500 tons of structural steel will be required. Contracts have been let as follows: For the foundation, Goosline & Swan, Rochester, N. Y.; for fabricating structure, McClintic-Marshall Construction Company, Pottstown, Pa.; for erection, Jobson-Gifford Company, New York. Membrane waterproofing, made by the H. W. Johns-Manville Company, New York, will be used.

**UTICA, N. Y.**—The New York Central & Hudson River is building a new passenger station at this point. J. Henry Miller, Inc., Baltimore, Md., is the general contractor for the passenger station proper, and Henry R. Beebe, Utica, is the contractor for the passenger and baggage subways. This company has just completed the construction of a thirty-stall engine house at Utica.

**NORTHERN CENTRAL RAILWAY, COLOMBIA.**—Construction work on this line has been stopped. There are few parts of South America which offer greater physical drawbacks than this portion of Colombia. The line was commenced from the swampy and desolate banks of the Magdalena river, at a dismal fever and mosquito-haunted place called Puerto Wilches. It was intended to carry the railway through the forests, across mountains and over torrential rivers and streams until it reached Bucaramanga, the center of a rich and thriving agricultural and mining district in the heart of Colombia, hitherto entirely without any other means of transportation than the mule or donkey. Upon the construction of this new route some of the most skillful and enterprising railway engineers of the day have been engaged, and in few parts of South America would it be possible to find better examples of railway track-laying, more admirably constructed bridges, stronger earthworks and retaining walls, or, indeed, a more conscientiously built line from start to finish. A difficulty about the government guarantee threatens to ruin the entire enterprise.

## Railway Financial News.

**BUFFALO, ROCHESTER & PITTSBURGH.**—Kean, Taylor & Company, New York, have bought from this company \$500,000 series G 4 per cent. equipment trust bonds.

**CINCINNATI, HAMILTON & DAYTON.**—The Public Service Commission of Ohio has granted permission to this company to issue \$787,000 first and refunding unguaranteed 4½ per cent. bonds as security for a loan, the amount of which is to be not less than 80 per cent. of the face value of the bonds.

**ILLINOIS CENTRAL.**—The directors have declared a semi-annual dividend of 2½ per cent., thus reducing the annual rate from 7 to 5 per cent. The company has been paying 7 per cent. since 1905. The Union Pacific owns directly and indirectly \$31,700,000 Illinois Central stock.

**SEABOARD AIR LINE.**—This company has sold \$1,900,000 5 per cent. equipment trust notes to the Equitable Trust Company, Kean, Taylor & Company, and Eastman, Dillon & Company, all of New York. The company is paying 15 per cent. in cash for the equipment which is to be security for the notes.

**SOUTHERN PACIFIC.**—See an item in Court News in regard to this company.

**UNION PACIFIC.**—In a note accompanying the preliminary statement of the income account for the year ended June 30, 1913, C. B. Seger, vice-president in charge of accounting, explains that while the estimated surplus of \$32,616,465, after the payment of 4 per cent. dividends on the preferred stock, is \$2,558,216 greater than at the end of 1912, and in 1913 is equivalent to 15.06 per cent. on the total outstanding common stock, the 1913 surplus does not include the fourth quarterly dividend on Southern Pacific stock, payable October 1, 1913, amounting to \$1,899,750, although the corresponding dividend for the preceding year, paid on October 1, 1912, is included in the surplus for the year ended June 30, 1912.

The first quarterly dividend on the Southern Pacific Company stock, payable January 1, 1913, was collected on the full amount of 1,266,500 shares [\$126,650,000]. The second and third quarterly dividends, payable on April 1 and July 1, 1913, have been collected on the 382,924 shares [\$38,292,400] (this brings the amount of stock sold to the Pennsylvania); while on the remaining \$88,357,600 stock the dividend has been collected by the Central Trust Company of New York, and such dividends will be received in connection with the offer now pending to Union Pacific stockholders of subscription rights to certificates of interest representing the Southern Pacific stock, and the amount is therefore included in income from investments in 1913 income account.

See also Illinois Central.

**WABASH.**—Judge Sessions has authorized the receivers to issue \$14,000,000 6 per cent. receivers' certificates to provide for maturing receivers' certificates which were issued February 1, 1912.

**BANGKOK-SINGAPORE RAILWAY.**—The British and the Siamese governments are considering a proposal to run the Bangkok-Singapore Railway down the west coast of the Malay peninsula, so as to pass through Kedah and the province of Wellesley and bring Penang within a few days of Bangkok and giving a much quicker mail route to Siam. It was originally intended to run the railway down the east coast, passing through Kelantan and Pahang, and so missing Penang. If this proposal is sanctioned it will mean considerable acceleration in finishing a route direct from Bangkok to Singapore, as the work of constructing the extension from the Federated Malay States Railway main line at Bukit Mutajam in the province of Wellesley to Alor Star, the chief town and capital of Kedah, is well in hand, and it is proposed to extend the line still further to the state of Pulis, of which Kangka is the chief town. The distance from Bukit Mutajam to Alor Star is, roughly, 65 miles, and from Alor Star to Kangka 30 miles, making a total distance of nearly 100 miles, of which part is already constructed and surveyed. This construction work will be carried out by the construction department of the Federated Malay States Railways. The Siamese portion will be constructed by the Siamese Royal State Railways.

# Railway Age Gazette

PUBLISHED EVERY FRIDAY AND DAILY EIGHT TIMES IN JUNE, BY THE  
SIMMONS-BOARDMAN PUBLISHING COMPANY,  
WOOLWORTH BUILDING, NEW YORK.

CHICAGO: Transportation Bldg. CLEVELAND: Citizens' Bldg.  
LONDON: Queen Anne's Chambers, Westminster.

E. A. SIMMONS, *President.*

L. B. SHERMAN, *Vice-President.*

HENRY LEE, *Sec'y & Treas.*

The address of the company is the address of the officers.

### EDITORS.

SAMUEL O. DUNN, *Editor.*

ROY V. WRIGHT,  
*Managing Editor.*

H. H. SIMMONS

E. S. FAUST

W. E. HOOPER

H. F. LANE

F. W. KRAEGER

B. B. ADAMS

E. A. AVERILL

A. D. CLOUD

E. T. HOWSON

R. A. THAYER

GEORGE L. FOWLER

A. C. LUDON

Subscriptions, including 52 regular weekly issues and special daily editions  
sent from time to time in New York, or in places other than New  
York, payable in advance and postage free:

United States and Mexico.....	\$5.00
Canada.....	6.00
Foreign Countries (excepting daily editions).....	8.00
Single Copies.....	15 cents each

Preparation and Maintenance of Way Edition and four Maintenance of  
Way Edition Daily issues, North America, \$1.00; foreign, \$2.00.

Entered at the Post Office at New York, N. Y., as mail matter of the  
second class.

WE GUARANTEE, that of this issue 8,150 copies were printed; that of  
these 8,150 copies, 6,700 were mailed to regular paid subscribers and 848 were  
provided for counter and news companies' sales; that the total copies printed  
this year to date were 275,788—an average of 8,618 copies a week.

VOLUME 55.

AUGUST 8, 1913.

NUMBER 6.

## CONTENTS

### EDITORIAL:

Editorial Notes.....	213
Telephones in Ticket Offices.....	214
Organization Problems.....	216

### LETTERS TO THE EDITOR:

Suggestions for More Efficient Organization; by N. E. Bailey.....	216
---	-----

### MISCELLANEOUS:

"Cotton Belt" Freight Terminal at St. Louis; by Winters Haydock.....	218
Are You Watching the Coal Pile? by D. C. Buell.....	221
*An Unusual Signal Installation.....	223
*Extensive Improvements on the L. & N.....	225
*Safety Exhibit Car.....	228
Principles of Electric Railroading; by C. L. de Muralt.....	230
*New End Construction for Pullman Cars.....	231
Decision in the Express Rate Cases.....	233
*Electric Trucks in Freight House Service.....	236
A New Public Service Law in Pennsylvania.....	238
Railroad Smoke Inspectors' Association of Chicago.....	239
*Rumsey Mail Car Door.....	240
Foreign Railway Notes.....	217, 220, 224, 228, 229, 235, 238

### GENERAL NEWS SECTION.....

\*Illustrated.

FIGURES which are compiled in the auditor's office and are sent to superintendents often carry hardly enough weight to make their compilation a paying investment. In the first place, in a great number of cases the superintendent cannot from his own records check up these figures. Naturally, if they make his showing bad he has a feeling of resentment which results, however, in no better showing next month because he cannot analyze his figures. One great trouble is that in the history of the organization of a railroad company the various individuals who have in the past had authority to order the compilation of certain classes of information have left the dry form of what was to them a living and useful work, and these forms have been deposited one on top of another until on some roads the mass of them has become almost impressively superfluous. A new man becomes general manager. His particular temperament, or the particular situation which

he has to meet, leads him, after careful study, to desire certain daily or weekly information. He issues orders that such information shall be compiled. On the other hand, he does not understand why certain information has been compiled in the past and is being compiled; but he is afraid to issue orders to abandon its compilation because he respects the work of his predecessor, and he fears that the reason he is abandoning it is because he does not understand it. A very considerable sum of money could be saved by most of the railroad companies in this country if a thorough housecleaning were made of all information, statistics, etc., for which there is not now a present need and of which those for whose benefit it is supposed to be compiled cannot directly see the advantage.

THE tramp problem shows no signs of letting up. Even if local magistrates were to waken to their duties and pursue a vigorous policy, the railway, being in the thick of the conflict, cannot do otherwise than constantly force the fight. A recent number of the *Scranton Times* tells of conditions in Northeastern Pennsylvania as follows:

It is not uncommon for five or six arrests of men and boys to be made daily by local railroads for illegal train riding. As long as men endanger their lives by jumping on or off of moving trains, riding on trucks, or between the cars on coal trains, and in every way endanger their life and ride in the most uncomfortable manner, one would think they were punished sufficiently, without the railroad authorities hauling them before the courts and locking them up at public expense; but this is not all; the railroads are made the victims of broken freight cars, and merchandise is stolen by the hoboes. And the free riders are too often a class of criminals who live on the public by stealing, enter homes at night, and quibble at nothing to get a living without work. In the best interests of the public, the railroads are doing a good service in their efforts to break up illegal train riding. The tramp problem, via railroad or public highway, is a big one that has not yet been solved.

In Western Massachusetts the news columns of the daily papers tell of similar activities. On the Pennsylvania Railroad, the less offensive class of trespassers—berry pickers, picnic parties and such like—are said to be making much work for the railroad police. Why would it not be a good thing for the railroad press agents to compile a large record of arrests and convictions, and of wise and unwise action on the part of courts, and circulate it among railroads and magistrates generally? Some railroads do not do their full duty. Many magistrates do not tackle the problem seriously enough. Apparently the railroad officers of the country are the only people who can stir the magistrates. Other interests suffer from the tramp nuisance, but seem to be helpless. Are the railroads to remain forever helpless? To exterminate tramps is, perhaps, more distinctly altruistic than to run "good farming specials" and teach farmers how to raise potatoes, cotton and cattle; and the job is far less pleasant; but the satisfaction of doing a good thing for society is present in both cases.

A NEW idea in the conduct of safety first campaigns has been inaugurated on the New York Central Lines. A safety exhibit car, described on another page, has been fitted with models of safeguards for machinery and other apparatus, and also with photographs showing graphically how the more common kinds of accidents occur and how they may be prevented. While the safety department of the New York Central has conducted an aggressive and successful fight toward the reduction of accidents to employees, it was felt that there were many men who could be reached and influenced by the safety exhibit car that were not now actively interested in the safety first movement. For instance, among other things, it has been the practice of Mr. Dow, the general safety agent, to hold safety meetings at terminals and division points to which the men and their families are invited. This is all well enough, and such meetings have been largely attended, but many of the men do not feel altogether at home at such places and, therefore, do not attend. On the other hand, these men will not hesitate to visit the exhibit car, which they can conveniently do in their working clothes and without special effort. Moreover, the working models will make

a much greater impression on them than the stereopticon pictures which are shown at the public meetings. While the exhibit car is also accompanied by a lecture car, the number in attendance at these lectures will necessarily be very much smaller than at the mass meetings, and ample opportunity will undoubtedly be afforded for the asking of questions and the discussion of features which may not have been made clear to some of those in attendance. After the lecture has been completed, those present can visit the exhibit car and have a very much better understanding of the various features of the exhibit. The safety first movement on the railroads has been very successful throughout the country and a large number of roads have organized the movement in such a way as to place it upon a permanent basis. One of the greatest difficulties in furthering it will be from time to time to so modify or change the methods of encouraging the employees to follow it that they will not lose interest. From this standpoint the safety exhibit car on the New York Central is a most interesting development and promises to add much to the interest of the movement on that system.

**T**HE Philadelphia & Reading carried to and from the Gettysburg anniversary celebration in July about 70,000 passengers— $3\frac{1}{2}$  million passenger miles on the 25-mile Gettysburg branch alone; and it expended around twenty thousand dollars for the insurance of these passengers against death or injury by collision. That is to say, this 25-mile line was fully equipped with automatic block signals, for this occasion; and after the rush was over the signals were taken down. This very unusual installation is described on another page. We have no official figures, but, roughly, the materials and work cost \$25,000, and the salvage amounted to \$7,000. Though the block system has been used in this country for over 40 years, and under a great variety of conditions, it has been difficult in the great majority of cases to learn with any precision the financial considerations which were held by the owners of the roads to justify the initial expenditure. Here, however, the case is quite clear. There was no thought of the future; the whole expenditure was chargeable to two temporary elements: 1, to secure the shortest practicable time interval between the excursion trains, and 2, to prevent collisions; in other words, insurance. If the receipts from these passengers were as much as two cents a mile the gross amount for the 25 miles was \$70,000. This makes the insurance very costly; perhaps 25 per cent. of the whole income. This, however, is not a fair calculation. Most of these passengers traveled over other and longer divisions of the Reading, and the company's total income from them was much more than the sum named. Any loss by reason of collision would have been a burden on the treasury of the whole Reading system and any disaster of any kind would have affected the reputation of the company everywhere. The expenditure for signals therefore cannot be fairly charged to the Gettysburg branch. The adoption of the automatic block system instead of the manual—which, with the electric train staff, well adapted to temporary use, would insure a high degree of safety—must be considered a great triumph for the track circuit and for the young American engineers who have perfected it.

**G**OOD railroad service receives appreciative notice, now and then, in spite of the critical spirit with which the atmosphere is constantly charged. In freight service, one of the cheapest things in the world, appreciation depends largely on cold calculation; and any road, even one with a doubtful reputation, can extort commendation if it "delivers the goods" and gets the consignees to note the fact. But we refer now to passenger service, and the illustration that we have in mind is the following note from the Philadelphia *Public Ledger*:

When President Wilson makes a quick trip across the state we hear a lot about the "terrific speed." But tens of thousands of Philadelphians who go to Atlantic City every week ride equally fast, but they do not seem to appreciate it. All the 60-minute trains on both railroads [Pennsylvania and Reading], and many of the other trains as well, travel more than 70 miles an hour for a considerable part of the distance. The average speed

for the entire distance is around 65 miles an hour for a few of the trains each day, and they must do at least 75 miles a part of the way. These are America's swiftest trains, but they have been doing their stunt from Philadelphia to the sea for so long [15 years or more] that travelers on them forget the novelty.

Yes, indeed! It is no novelty. And these speeds are made on a considerable number of other lines, between the Atlantic ocean and the Missouri river. It is not novel, but it is costly. The Atlantic City lines have an advantage in their straight and level country, their equable climate and their freedom from heavy freight traffic; and they deserve the credit which they accorded for very high speed, very good roads and a high record for safety. But expenditures of money and skill, equally creditable when considered in comparison with the obstacles to be overcome, may be seen in connection with large numbers of fast trains elsewhere. One reason, no doubt, why good passenger service often fails to elicit commendatory notice is that in our widespread luxury we get into the habit of demanding the best everywhere, whereas, in the majority of cases only second best can be afforded. We want more than we can pay for. Here, as in other matters, virtue is commonplace, while the opposite excites eloquence, even in the ignorant. A hundred rustic "guys" can denounce a railway's shortcomings where only one cock-headed citizen will appreciate the costs and obstacles, and make the comparison with other features of civilization which are necessary to properly value such a product of railroad enterprise as an extensive train-service which makes a perfect record, with the highest speed, for a long series of months or years, and all at a cost of two cents per mile per passenger, or less. The Atlantic City lines are not less notable for speed and safety than for economy. This is a very proper ideal to be aimed at everywhere; but complete realization, even on the best roads, must be slow in coming. In the meantime thoughtful editors can find many other places where they can bestow praise. Many editors are now friendly to railroad presidents, and railroad financiers and traffic managers; they can find equally good things to engage their interest among the superintendents and master mechanics, the men who manage these fast trains.

#### TELEPHONES IN TICKET OFFICES.

**P**OLITENESS has been the rule in ticket offices from time immemorial. It was the rule even in the old days of the browbeating ticket seller, who abused passengers at will when their conduct did not suit him. The agent's barbarous doings were exceptions. And, unfortunately, exceptions are common, even to this day. But with the introduction of the telephone this rule has been made more important and significant. In answering questions over the telephone the clerk who is disposed to be ungenerous to passengers has a new and different temptation to indulge his unbusinesslike propensity, and some railroads have issued circulars specifically reminding station men that their behavior at the telephone was likely to be an important factor in making or marring the reputation of the company.

But is there no limit to the demands on the ticket agent's courtesy? Can people go on asking their idle questions forever? At the ticket window the stream of questioners sometimes lets up; and for a part of the time the window can be closed. But with a telephone in the office there is no time limit, and the number of possible questioners is limited only by the size of the town. Everybody, even ladies in their boudoirs, or the janitor in the back cellar, can ask questions; and at train time, when the agent is busiest, the questions are most numerous. One of the earliest railroad agents to have a telephone in his office was H. C. Hamilton, about 1877. Asked by the writer at that time how it affected the office routine, he replied that the principal change was in the increased wear of shoe leather, walking to the other side of the room to answer the inquiries of merchants expecting freight. From that day to this it has been the same. At the Grand Central Terminal, New York, the more extensive information bureau is not that which is visible to the public at the time-table case in the waiting room, with its two or three attendants; it is in the

secluded telephone room, where ten men spend their time in answering questions; and for a large part of the day four or more of these men are at work at the same time. And they deal almost wholly with passenger business, no freight station being connected. The telephone has become a part of everybody's life, and the railroad man can be no exception.

This subject was called to mind by the receipt of a letter from a correspondent, a woman living in a small city not far from New York, which in substance reads as follows:

How is it that in the matter of telephone communication our railroad stations are the least enterprising of any business places with which people have to deal? Desiring, one day recently, to make a somewhat unusual journey, on short notice, I took the very natural course of going to the telephone to make inquiries of the ticket agent as to the time of the trains, and the fare, and the routes; but what was my surprise to find that there was no railroad office listed in the telephone book—except the office of the freight agent, which, being a quarter mile away from the passenger station, was not able to be of any benefit to me in that particular case.

With a view to giving to this question a comprehensive answer we made inquiries of railroad officers in New England, New York, Pennsylvania, Ohio, Illinois, the far west, the south, and Canada, and we have received a lot of interesting replies. To the question of the ticket agent, whether there can be a limit put to the number of his questioners, or to their fatal ingenuity, the answer is, unequivocally, "No." He must be patient and courteous till he dies. In addition to this he must be intelligent and well informed; his answers must have solid substance as well as good form. Moreover, this is good for him, personally. An officer of the Chicago, Burlington & Quincy informs us that in cases on his road the station agents have been the first to call the officers' attention to the need of a telephone, believing that their own advancement would be promoted by the use of the telephone, in attending to the wants of patrons, as a means of making for themselves a good reputation.

Taking it for granted that a railroad station should be conducted with as much intelligence and enterprise as a store—stores have taught us most of what we know about pleasing customers—we may say it should have (1) a telephone in the ticket office, (2) one in the freight office, and (3) a pay station (booth) in the waiting room; and our correspondents furnish a mass of testimony as to the wisdom of providing adequate telephone facilities which we will try to summarize.

Taking the last point first, a telephone—or a sufficient number of telephones—for the convenience of the public, is in these days only a reasonable convenience. In the stations of the subway in New York City, the State authorities are moving to have public telephones installed, even though they are obliged to go to the legislature for a special act, the law under which the subways were constructed having been drawn in such strict terms that at present the premises cannot be used for other than transportation purposes. With telephones in railroad stations the inspector of stations should see that the agents take sufficient interest in the booths to know that they are always kept in neat and presentable condition. It is worth while also to take enough interest in the service to keep track of the passengers' complaints, if any are made. The service should at least be as good as can be had at first-class drug stores. The nickel-in-the-slot machines are destined to make the telephone universal, and users of the wires desire, of course, to get as good service from one telephone as from another.

With up-to-date superintendents, the telephone in the freight house has long since fully justified itself. While it adds to the number of questions which the freight agent or his clerk must answer, it is a means of decided economy in expediting the delivery of freight. One superintendent says definitely that the telephone is much more than paid for by the number of days saved on cars of bulk freight, through the facility it affords for giving to consignees prompt notice of arrival. The value of this feature is especially marked in rural districts where mails are infrequent. Practically all our correspondents say that their stations have telephones in towns where exchanges are in operation; but on the Missouri Pacific, we are informed that even the

"farmers'" lines are in some cases run into the stations.

The ticket-office telephone, not being so obviously profitable as the one in the freight office, has not made so much progress. Some officers intimate that their own roads are not in this matter quite up to the needs of the public. In the large cities the information bureau, with its attendant always on duty to answer questions, has become an established institution. At the other extreme, the small country station, manned by a single agent, the telephone also does its full duty, as the agent is not overburdened with so many duties and the questions coming to him are not burdensome in their number. But in moderate-sized towns, the situation is frequently rather complex. One manager says frankly that this subject is one of the most troublesome with which he has to deal with in the station service. It will often happen that the agent, or the agent and his assistant, are interrupted in their work to an unreasonable degree, while yet the employment of an assistant, even at a small salary, does not seem to be warranted. A girl, employed especially for telephone work, does not always fill the bill, for many of the questions coming over the telephone have to do with rates of fare and other matters concerning which only a well-posted ticket man can answer. Questions come thickest just about train time, when a ticket seller is busiest. And there is no escaping many unnecessary questions. The manager of a Western road says:

It is a fact that this convenience is abused. Take the early summer especially, when people are planning to go on vacations, it takes practically all the time of one man, in towns of any considerable size, to answer questions and quote rates; and two-thirds of the rates are quoted to points to which people never have any intention of going. They merely think it would be a nice trip, and so they satisfy their curiosity about trains and fares. And, once having become used to the telephone, people will call up on the 'phone to see if a train is late when they are expecting a visitor, or if they are taking a trip, even if there is no expectation that the train is late.

But, whatever the obstacles, the telephone is necessary; and, having made it a part of the machinery of an office, there is no rational course but to keep it in the best possible working order. If there is a competing railroad in town the spur of rivalry will be always present. If there is no competitor and the spur of ordinary business ambition is not enough, the State Railroad Commission, or the shadow of coming decisions of the commissions, should be a sufficient incentive to good service. Missouri, Kansas, Nebraska and Oklahoma have already passed laws to make the railroads provide the facilities the people want.

Many of the most enterprising railroads print the telephone numbers of the passenger offices in their advertising matter, and this practice will no doubt be extended. One passenger traffic manager believes that the time has already come when the publication of time-tables in local newspapers is unnecessary; people desiring information about the trains will call up the railroad office. Where the ticket office and the freight office are together the entry in the telephone directory should clearly indicate that the number is available both for passenger inquiries and for freight inquiries; and where the offices are separate the same information should be made clear.

The railroad with which our woman friend had to deal evidently was not quite up to date. The superintendent who has charge of that station may expect to hear from the State Public Service Commission, unless his state is an unusually slow one. As one general manager says in his letter to us: "The telephone; electric light; municipal water in place of a station pump; water closets heated and lighted, instead of the old arrangement; flower beds and shrubbery from the nursery; improved driveways (*i. e.*, paving block, instead of dirt roads); janitor service; matron service, and other things which might be enumerated, are fixed charges which have come to stay, and which have added their weight to the very considerable excess 'cost of living' over what our fathers knew a generation ago; or even ten years ago, for that matter. Everybody has become accustomed to finding a telephone on his desk, and to class as indispensable many facilities which were unknown when you and I entered railroad service." To this condition the railroads must conform.



### ORGANIZATION PROBLEMS.

IN making suggestions looking toward a better form of railway organization, Mr. Bailey, in a letter which appears in another part of this issue, has made use of a chart to more clearly define the lines of responsibility which control the different officers and men in the organization. Marked improvements have been made in the conditions on some roads where attempts have been made to chart the existing organizations in this way. In many cases it became apparent almost before the work had been well started that there were possibilities of conflict of authority because of the crossing or confusion of the different lines. To overcome this it was necessary, at least in some cases, to make rearrangements and changes. Generally speaking, the simpler the form of organization the more efficient it is, and a good test of its simplicity is to attempt to diagram or chart it. If the lines of authority are not clearly evident so that the chart may be easily made, something is wrong and needs to be remedied.

Even if the organization can be clearly charted there is still room for considerable confusion and misunderstanding unless the exact limits of authority and responsibility of each member in it are clearly defined. The lines of demarkation between the limits of authority of the various officers is more or less hazy on some roads, resulting in friction and frequent misunderstandings. On other roads, because of tradition, or due to the personalities of the men who may have been among its officers, the lines of demarkation are often more or less irregular and differ greatly from those on roads where the conditions are better balanced. In these days when a road like the Canadian Pacific, for instance, finds that it is profitable to clearly define in the form of standard practice cards the exact procedure to be followed in performing minor operations in the mechanical department, it seems strange that railways will allow the efficiency of the entire organization to suffer because the limits of authority of its officers are indefinite and have not been reduced in writing to clear, clean-cut statements. Can the general officer who is responsible for this uncertainty afford to excuse himself on the plea of having other duties to perform which prevent his giving it the required amount of attention?

In commenting on "The Human Element in Industrial Management" in our issue of July 25, the statement was made that the problem of industrial efficiency will have to be solved by the development of a sufficient number of strong executives who understand how to train and handle men and to take advantage of the best things in science and practice to secure the maximum of efficiency with the minimum of effort. Are these men being developed as fast as they should be on our railways, and is the form of organization which obtains on many roads such as will make it possible to develop these men? In the first place, something besides a haphazard, or hit-and-miss method must be used to select from the ranks those men who are to be developed into good foremen and executives. In the next place, the remuneration should be such as to attract and hold such men. For instance, cases are not at all unusual where trainmasters, foremen, shop superintendents, traveling engineers and master mechanics receive less compensation than do some of the men who are working under them on a trip or piece work basis and whose responsibilities are not nearly so great. Is it to be wondered at that so many promising young men leave the railways for more lucrative positions in the industrial field?

A bright and ambitious young man, anxious to enter railway service, approached an older friend who was thoroughly familiar with railway and industrial conditions and asked him for advice. The older man replied, "I would advise you not to do so unless you want to get a few years of experience, but that is all there is to it. Get your experience and then go where you can get paid for it." This is pretty strong advice and one of the most important improvements that should be brought about in railway organization is to overcome this condition.

## Letters to the Editor.

### SUGGESTIONS FOR MORE EFFICIENT ORGANIZATION.

JEROME, Ariz., July 29, 1913.

TO THE EDITOR OF THE RAILWAY AGE GAZETTE:

Your issue of July 11 contains extracts from the testimony of President C. S. Mellen of the N. Y. N. H. & H., before Coroner Phelan at Bridgeport, Conn., July 7. From these extracts it would appear that the duties of the vice-presidents of that road were not specifically defined and it is fair to presume that a like condition of affairs prevailed as regards the duties of other officials. Speaking of the duties of the vice-presidents, Mr. Mellen said, "In railroad circles there is a well defined line of demarkation in this respect, which is not specified in the notice (of appointment) or by any order of the president." I believe that that statement is absolutely true and that it is responsible for a very considerable part of the lack of efficiency and good management in the operation of our railroad systems.

The astonishing part of the testimony to me is that the duties of important officials are left to their judgment and experience. No two men have the same judgment nor experience. All men are more or less selfish, and most men are vastly ambitious. From close observation, covering many years' experience I am led to believe that the petty jealousies, apparently inherent in most subordinate officers, are not necessarily confined alone to such officials and that the higher one gets in the management of a railroad the more detrimental to efficiency become efforts of such officials to secure all possible power and authority, outside of what properly belongs to their respective positions.

While the lines of demarkation are fairly well marked there are many places of apparently overlapping authority; the authority of officials is often not sufficiently defined for them to determine just where this line may be and there are consequently many clashes, which greatly redound to the detriment of the service.

The official list on practically every railroad in the United States is made up of men secured from every part of the country. On practically no two roads are the lines drawn exactly alike and men come together from different roads with divergent ideas of their authority. Where one character is particularly strong, assertive, ambitious or unscrupulous, he will often gradually encroach upon the authority of others, until the custom grows up on that line for him to exercise authority never intended for his position. This is often conducive to internal dissensions, which make for lax discipline and poor efficiency. The men instinctively take up the feeling held by their respective heads and the ugly spectacle is often seen of entire departments being at loggerheads with one another. It is also often the case that these conditions do not come to the attention of the higher officials, or, if they do, are made light of and not given the attention which their importance deserves. In many cases the authority is a divided one up to the very head, who lives in such a mass of responsibility, who has such vast properties under his control, as to make it practically impossible for him to attend to such an apparently small matter, and, as a result, this unhealthy condition grows continually worse and brings in its wake much that is condemned in railroad management.

What official, on a vacation trip over other roads, cannot see acts of gross inefficiency or carelessness and does not determine that such things shall be remedied on his own line when he returns? How often, however good his intentions may be, is he so plunged into other distracting work or so hedged about with conflicting authority on his return as to render any improvement practically impossible.

I have come to the conclusion that the best remedy for these conditions is to more clearly define the authority of all officials and to limit the units of operation so as to make it possible for

unit heads to more closely supervise such units. The tendency of latter day railroading is to increase rather than diminish the divisions; to increase the scope of the higher officials until they sometimes not only exercise authority over vast mileage on one line, but often hold similar positions on two or more lines. In the very nature of things, it becomes impossible for men occupying such positions to give more than cursory attention to many important matters. In support of this I might again call attention to Mr. Mellen's testimony, as well as to many other changes in management of late date.

In making more definite the lines of demarkation, I believe that every road should be charted, and in addition thereto the duties of every official should in a measure be defined—amplified by explanatory notes. Conferences should be held periodically, these matters taken up, discussed dispassionately and any doubts dispelled by decisions from competent authority. In this way each department head will understand just exactly the lines of

division superintendent should report directly to the general superintendent and indirectly to the chief engineer, superintendent of motive power, auditor, and other general officials.

I would have, where practicable, all division officials grouped in one consolidated office, separated into departments, but with a common head. This is a modification of the Hine system and is, I believe, an improvement over that excellent system.

After all is said and done, however, the unit which is successfully operated is so operated largely because of the personal equation of the unit head. Where the department head knows the exact limits of his responsibility, has decision and common-sense and can infuse into his subordinates an exemplary spirit of co-operation and loyalty the unit will be efficiently and successfully run, but where the unit head does not have these faculties, lost motion and inefficiency is certain to prevail. A clear understanding of the duties and authority pertaining to any position, and of just what is expected of a department head should, how-

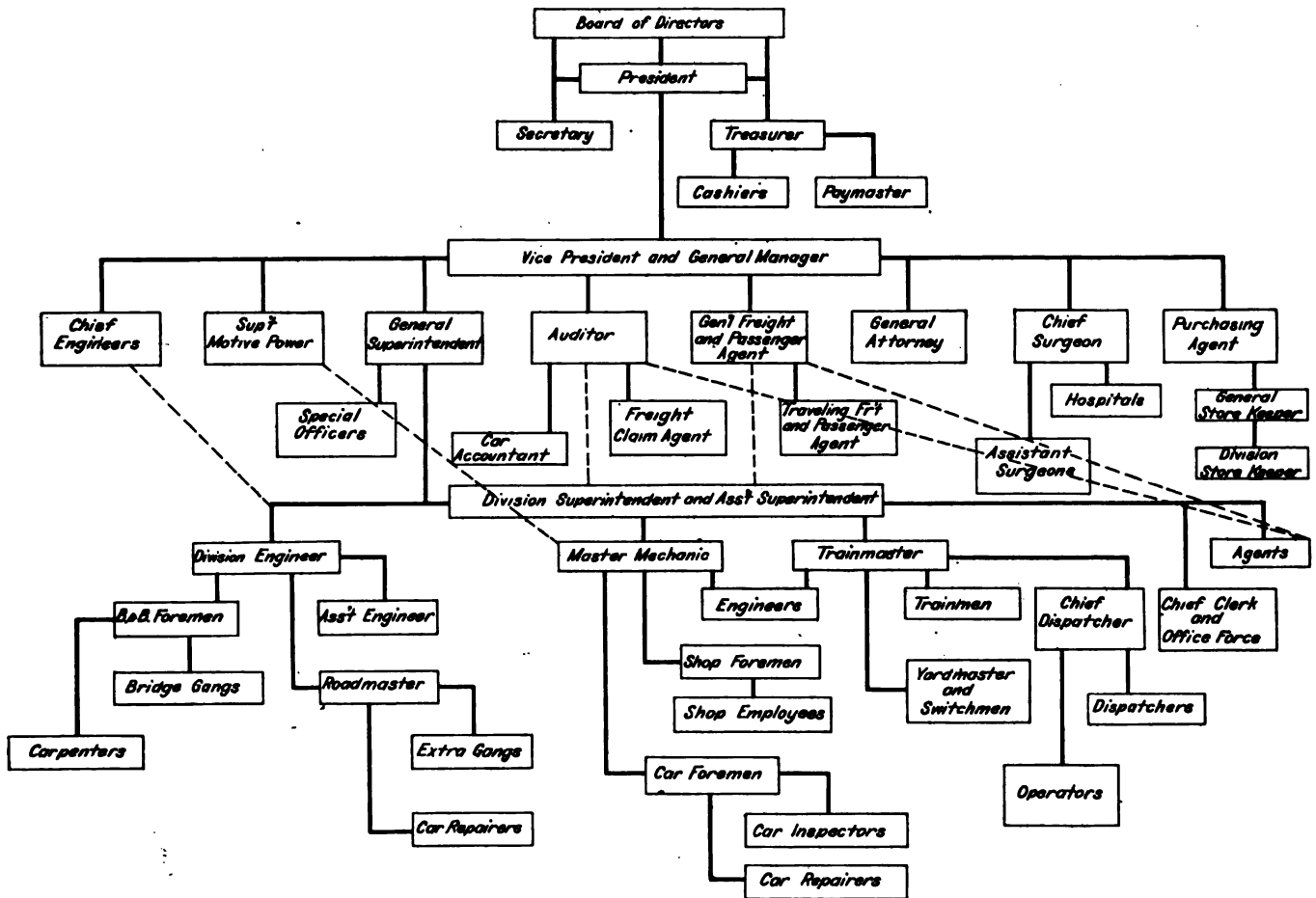

A Suggested Form of Efficient Organization for a Railway.

demarkation of his authority, and also those of each other official. In charting I would suggest, for any but the largest railroad systems, something similar to drawing. On larger systems, where more vice-presidents are employed, the diagram may be very easily changed to suit conditions.

It will be noted on the chart herewith, that the division superintendent is made the absolute unit head, all division officials reporting directly to him or to the assistant superintendent, as may be determined. This does not preclude the chief engineer from securing information, etc., from the division engineer, but it should be done through the division superintendent. The same process applies as regards the mechanical department. Where it is not considered expedient to employ a chief engineer or superintendent of motive power, their duties may be assumed by the general manager or by the general superintendent. The

ever, add immensely to the efficiency of any official and greatly rebound to the successful management of the railroad affected.

N. E. BAILEY,  
Gen. Supt., United Verde & Pacific Railway.

DUTY FREE COAL FOR RUSSIAN RAILWAYS.—The Duma in St. Petersburg has adopted the bills relating to the import free of duty of coal from abroad for the use of the state and private railways.

RAILWAY CONSTRUCTION IN INDIA.—On December 31, 1912, there were 2,455 miles of line authorized or under construction in India. This figure comprises 1,092 miles of 5 ft. 6 in. gage; 536 miles of 3 ft. 3 in. gage; 823 miles of 2 ft. 6 in. gage, and 4 miles of 2 ft. gage.

# "COTTON BELT" FREIGHT TERMINAL AT ST. LOUIS.

Occupies Three City Blocks and is Five Stories High.  
Building Narrow to Facilitate Trucking to and From Cars.

By WINTERS HAYDOCK,

Resident Engineer, St. Louis Southwestern, St. Louis, Mo.

The increase in the volume of freight handled at St. Louis by the St. Louis Southwestern, due to its expansion in Arkansas and Texas and to the recent development of these states, has necessitated the building of a large new freight terminal to replace the old and inadequate facilities. Several extensions to the company's lines have recently been built into new territory

of the St. Louis Transfer Railway, which is a part of the Terminal, are on Lewis street to the east. Lewis street is about 20 ft. lower than First street, and Florida and Dickson streets at the north and south ends of the property respectively, slope down from First to Lewis street on a grade of seven per cent. For the fullest utilization of the property, which had been bought

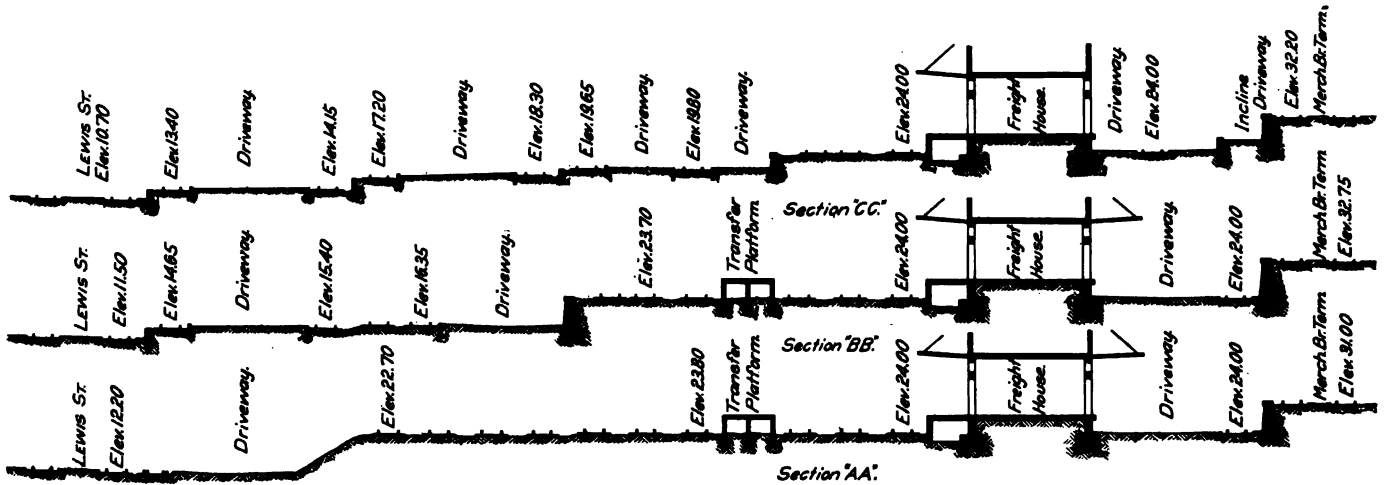

Sections Across Tracks at New "Cotton Belt" Freight House.

in Arkansas and Texas, and with every prospect of as great a future ratio of development in the old territory as in the past, it was the part of wisdom to make the new terminal ample for a large increase over present business, and to spare no expense in making it up-to-date and economical of operation.

at great expense, it was necessary in designing the yards to plan for a connection with the tracks both on First and on Lewis street. This involved a serious difficulty in design on account of the difference in elevation of these tracks and the steep slope of the property. The adopted arrangement pro-

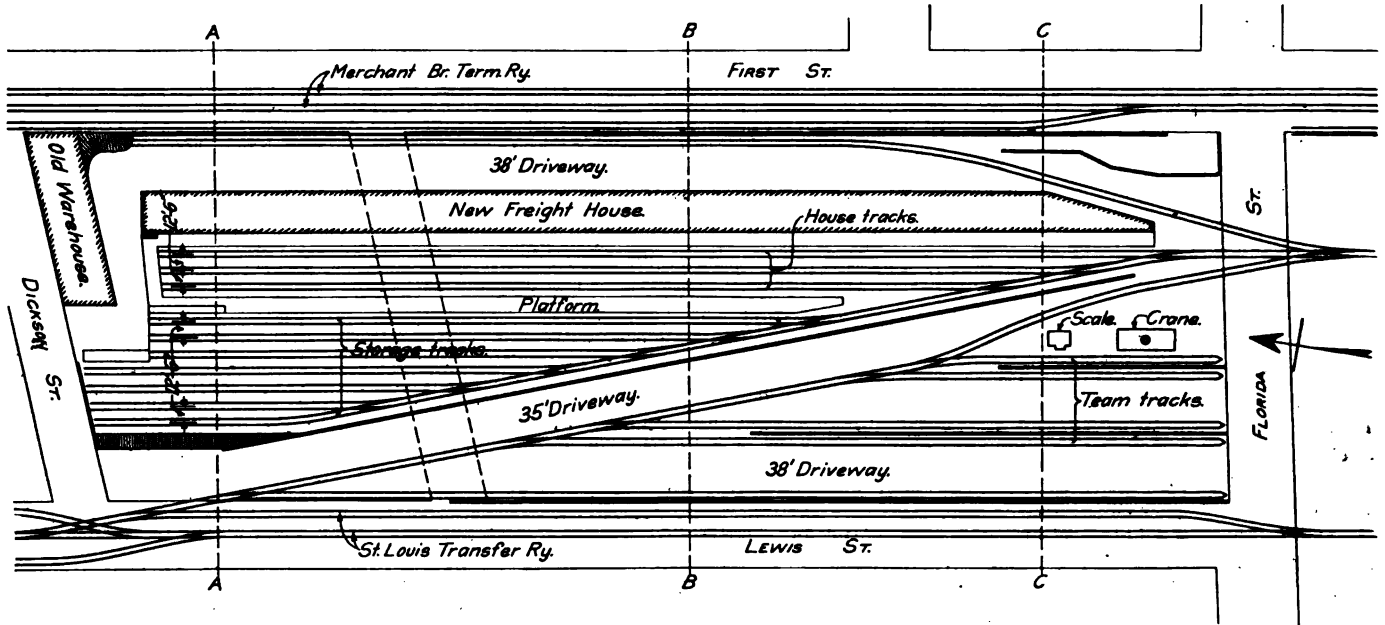

Track Layout at New "Cotton Belt" Freight House.

The new terminal occupies three city blocks between First and Lewis streets and Florida and Dickson streets. It is about 874 ft. long and 274 ft. wide. The main line tracks of the Terminal Railway Association leading from the Merchants bridge are on First street, west of the property, and the tracks

vide a maximum of convenience of operation with a minimum waste of space, without requiring steep grades.

The principal features of the terminal are briefly: a freight house 751 ft. long, 30 ft. wide and five stories high; a yard of 10 tracks to serve the freight house and for the storage of cars;

a transfer platform 500 ft. long; and a team track yard of five tracks. The difficulty of getting tracks into all four corners of a comparatively small rectangular area was overcome by running two ladder tracks diagonally through the property, from one of which the house and storage tracks lead toward the south and from the other of which the team tracks lead toward the north. Between these two tracks is a driveway diagonally from Florida

The design of the freight house was adopted in the belief that, though various systems of handling freight have been tried, such as telpherage systems, hoists, etc., nothing can surpass for economy the simple plan of trucking freight to and from the cars through a narrow building. Hence the building was made long for capacity and narrow for economy. It is 751 ft. long, 30 ft. wide and has a platform on the track side 10 ft. wide. On the west side is a driveway paved with brick. Steel rolling doors are provided on each side of the building and a 12-ft. concrete canopy is provided on each side. At short intervals along the middle of the building platform scales are set in the floor.

The building is five stories high and fireproof throughout, being of steel frame construction with concrete fireproofing around the columns and beams and reinforced concrete walls, floors and roof slabs. The floors are designed for a load of 500 lbs. per sq. ft., the panels between beam centers being 13 ft. 6 in. The four upper stories are intended for warehouse purposes and are served by four electric elevators. This extension of the plan to include a large warehouse area without using any more ground space was warranted by the permanent demand which exists for such space in St. Louis and by the additional freight business which such a warehouse connection would naturally bring. Each floor is divided into compartments about 100 ft. long by division walls having openings 12 ft. wide, provided with rolling steel doors with automatic fire latch. The entire building is protected by an automatic sprinkler system.

Near the north end of the building on the first floor is a large and well finished office for the bill clerks and cashier, and above this on the second floor is a larger office for the freight agent and his clerical force. On the first and second floors are seven toilet rooms. These and the offices are heated by steam from a boiler located in the cellar in the north end of the building. The vacuum system is used. One compartment on the third floor is also heated—this to be used as a storeroom for fruit.

A refrigerator room is provided on the second floor of the two-story building above the boiler cellar at the north end. The walls, floors and roof of this room are insulated with 3-in. cork slabs. Refrigeration through ammonia pipes is provided by the St. Louis Cold Storage and Refrigeration Company. This room is served by a special elevator.

In order to provide for the transferring of freight from car to car a reinforced concrete platform about 500 ft. long and 12 ft. 6 in. wide has been built between the third and fourth tracks east of the freight house. This is connected with the building by a cross platform at the south end. A convenient feature is a concrete end loading incline at the end of one of



New "Cotton Belt" Freight House from West Side.

street to Dickson street and a connection with the ends of the driveways between the team tracks. In the team track yard the elevations of the tracks and driveways conform in general to the seven per cent. slope, the various levels being divided by small retaining walls. The driveways of the team yard are paved with granite blocks and have concrete curbs. Features of the team track yard are a wagon scale and a crane of 25 tons capacity mounted in the middle of a concrete platform.



New "Cotton Belt" Freight Station from Team Track Side.

the tracks, providing an ever ready means of loading traction engines, threshing machines, boilers, fire trucks, automobiles, etc.

The work of tearing down the old buildings of the Charter Oak Stove Company, from whom the real estate was bought, was begun in September, 1911. Wrecking and grading were carried on during the fall. The severity of the winter prevented the accomplishment of much, except the erection of the steel frame. The tower and chute system was used in concreting in conjunction with hopper cars for the long hauls. About 15,000 cu. yds. of concrete were used in the entire construction. The long and

shields at the corners and a large terra cotta sign, all in verde-green.

The terminal was designed and built under the direction of C. D. Purdon, chief engineer, O. D. Schmidt, chief draftsman, bridge and building department, being the architect for the building. Thompson & Scott were the general contractors. The steel frame was fabricated and erected by Christopher & Simpson. The plumbing and heating system was installed by the Wm. Burke Plumbing Company and the sprinkler system by the Globe Automatic Sprinkler Company. Ed. Samen was superintendent



South End of New Freight Station During Construction, Showing Forms and Concrete Distributing Tower.

narrow form of the building lent itself admirably to economy in form-work. The outside wall forms were built in large panels 40 ft. 6 in. long and one story high. The beam, floor and inside wall forms were built in small panels light enough to be handled by two men. The concrete was poured in sections including about one-quarter of one story. While one of these sections was being concreted another was being erected by the carpenters; the form panels were moved from section to section and thus used over and over. The large outside panels were moved along the building and from story to story by a wooden traveler, which ran on rails temporarily placed on the steel roof beams. They were suspended from the traveler by multiplying chain hoists.

Architecturally the building is as pleasing in appearance as its massive design and utilitarian purpose warrant. The usually flat appearance of a concrete surface is relieved by verde-green terra cotta lion heads at the ends of the canopy rods, terra cotta

for the contractors and the writer was resident engineer. The terminal was opened for business on January 1, 1913.

**ROLLING STOCK FOR INDIA.**—There are to be built for the Great Indian Peninsula Railway 202 passenger cars, 1,386 freight cars and 112 engines. Provision has also been made for the construction of 500 box cars for the Bombay, Baroda & Central India, and 400 box cars for the East Indian Railway during 1913-14.

**INDIAN RAILWAY CONCESSIONS.**—A concession has been granted to the District Board of Tanjore for the construction, without rebate or guarantee, of extensions of the Tanjore District Board railway from Nidamangalam to Mannargudi (Madras) about 8 miles, and Tiruturaipundi to Vedaraniem (Madras), about 20 miles in length. The two extensions will be on the 3 ft. 3½ in. gage.

# ARE YOU WATCHING THE COAL PILE?

A Series of Questions and Suggestions Emphasizing the Necessity of Giving Detail Attention to the Fuel Problem.

By Dr. C. BUELL,

Chief, Railway Educational Bureau, Omaha, Neb.

Do you realize that on a medium-sized division the average cost for coal per day runs around \$2,000? If you will check it up on your division, and it is of average size, you will find this is not far wrong. With this in mind, let me ask the question as to how much time you are spending per month in looking after fuel matters. If you are a division superintendent or master mechanic, I will hazard the guess that there is not a week that you don't spend several hours "chasing overtime," and yet, probably, on your division overtime will not average much over \$1,000 a month; whereas, fuel costs will perhaps average \$60,000 a month. Under these circumstances are you giving sixty times the attention to your fuel costs that you are to your overtime costs? You ought to, on a basis of comparative statistics.

## AT THE COAL CHUTE.

Do you think to talk to the coal-chute foreman about how much coal is picked up off the ground each month, and what is done with it? Everything may be cleaned up around the chute, but this is no indication that an excessive amount of high class coal is not being spilled, picked up and shipped away for use at pumping stations. It is also well to find out if the pick-up coal is being properly credited or charged in the records.

While talking to the coal-chute foreman, do you find out how much "pencil adjustment" has to be made each month to balance the coal accounts at his chute? If there is such a pencil adjustment, do you investigate the matter with the station agent who handles the bills, and others concerned, to find out where the leakage occurs, and why there should have to be any more than a nominal adjustment?

Do you have statistics in your pocket so you know, when at a coaling station, what the cost of handling the coal is at that point? There are many ways to reduce the cost of handling coal at coaling stations which are not being carefully considered. There are many places, particularly at terminal points, where the distribution of labor is such that statistics show an excessively high, or perhaps an unusually low, cost of handling fuel, whereas if labor charges were properly proportioned such would not be the case. If it is costing more than three cents a ton to coal engines at mechanical plants, or more than seven cents a ton at pocket chutes, or over ten cents a ton at any point, it is a pretty good indication that there is a possibility of making a saving on this item if some little study is given the situation. At many small coaling stations, particularly of the older type, the work can in some cases be let out by contract at much less than the present cost.

Have you ever stopped to figure out what the cost of handling coal on your railroad is? You can figure this approximately by taking the average cost of handling per ton as nine or ten cents, and multiplying the total number of tons used by locomotives by that amount. The answer to this simple problem will surprise you.

Do you watch the operation of mechanical chutes to see whether some engines are getting all lump coal and some engines all slack? Slight modification of a chute at times will overcome this difficulty and result in considerable fuel economy on the road.

Does the coal-chute foreman understand that with run-of-mine coal there is often a considerable amount of slack along the side of the car that stood next to the tippie at the mine? If the coal-chute man understands this, he is probably making an effort to mix this fine stuff with the coarser coal. There are lots of other little items of interest around a coal chute that

a man with his eyes open will see. For instance: Will a stretch of 200 or 300 ft. of fence prevent the stealing of a lot of coal that is going on at present?

Is the coal being broken up to firing size at the chute so as to keep faith in the contract which you have made with the fireman?

Are coal-chute men giving certain engineers or firemen the worst coal or the best coal on account of personal dislike or preference?

Are the handling arrangements for the fireman proper and safe, so as to avoid risk of personal injury in taking coal?

Are the chutes provided with derails, and are they kept set to prevent possible accident?

Are the records being kept properly?

Are there any old company coal waybills stuck away in a corner that should have been sent to the auditor's office many months ago?

Is the foreman "on the job," so that engineers don't have trouble (particularly on passenger trains) locating the proper pocket to spot at?

Do you find out if the coal is coming to the chute in the right kind of cars? There probably is not a road in the country that does not have trouble in getting the right kind of cars to the proper plants. Hopper bottom cars go to a plant where there are no facilities for dumping through the hopper; and flat bottoms go to the plants where the hopper cars should have gone. It is hard to keep this straight, but it is not impossible if you keep after it, and lots of money can be saved this way, even on a medium-sized railroad.

Is coal being switched to the chute so that it can be handled with the minimum force?

These are just a few of the things. If your eyes are open the coal chute presents lots of problems in fuel economy, but if they are not open, it is just a coal chute, and ten chances to one a lot of money is going to waste unnoticed.

## AT THE STATION.

At coaling stations it is just as important to talk to the station agent as it is to talk to the coal-chute foreman. Do you find out how the company coal is coming, whether the billing is being handled properly, so that there can be an accurate record of the coal handled through the chute, not only at the station and in the division offices, but in the accounting office?

Do you ask the agent if the coal-chute foreman co-operates with him properly in returning company coal waybills, if they are handled jointly as in most cases?

Do you talk with him about the pilfering of coal, to see if this cannot be reduced? The confiscation of commercial coal is another important item.

Do you ever explain to an agent that it saves coal as well as time and money if his force is lined up so as to cause the least possible delay to passenger and freight trains? Perhaps he has never thought that a minute wasted at his station must be made up between stations and that it takes extra coal to do this. While talking about this, don't forget the importance of a first-class switch list.

While standing at a station, if you see an engine coming in making a cloud of black smoke, do you say anything to the crew about this being unnecessary?

If you are standing around a station and hear an engine popping off unnecessarily, do you ask the crew if they realize the waste?

These last two questions may seem somewhat foolish, but

one of the surprising features of the moving picture car work in connection with fuel economy was that if an engine was making black smoke anywhere around a terminal, or if an engine was popping off, there was some engineer, fireman, trainman or other employee who had seen the moving pictures who would stroll over to that engine and look up and holler: "Say, partner, haven't you been to that picture car yet?" This very thing made quite a difference in the amount of smoke and popping. How much more effective it would be if the superintendent, trainmaster, or road foreman did this instead of depending on the men to check each other up at a terminal!

#### AT THE CINDER PIT.

Do you ever get up on the string of engines waiting to be cleaned at the cinder pit, and examine the condition of the fires in these engines, to find out which crews are burning their fires down properly so as to avoid waste of coal, and which crews are careless about the matter, so that you can check this important item to prevent this waste? At the same time, do you pay attention as to which fires are clinkered and heavy and which are clean and light? This may make a difference of from half an hour to a couple of hours in the cleaning of the fire, and when you are at all short of power the condition in which fires are brought into the terminal plays an important part in the speed with which engines can be turned and made ready for service. There is another important item in this connection, and that is that if the men on your district are all bringing in light, clean fires, the cost of cleaning fires and turning engines can be materially reduced from what it is if the fires are in bad condition and clinkered. Inspection of the engines at the cinder pit gives you a mighty good line on which fireman to ride with and instruct in order to make a better fuel showing.

While you are around the ash-pit, do you watch the use of the blower to see what flues are not being mistreated?

Another thing that it is important to watch on the cinder-pit track is the way the water-tender does his work. If engines are popping off on this track continually, it is a pretty safe bet that before long you will see the water-tender getting up on some of these engines and putting more water in the boiler, and at the same time throwing more coal on the fire. There should be no excuse for engines popping on the cinder-pit track while waiting to have their fires cleaned.

#### AT THE ROUNDHOUSE.

Do you ever make a surprise test on the work done by the roundhouse men that affects fuel economy? For example: Have you ever gone into the firebox of a locomotive on which the work book shows "blow out flues," and the flue borer has marked the work "OK," and made a test with a torch to see how many of the flues have actually been blown out? If you have never done this you have a surprise in store for yourself.

Have you ever talked to the master mechanic about the particular importance of having flues kept clean on superheater engines? You must have noticed, if your eyes are open, that dirty flues on the superheater make an enormous difference in the steaming capacity of the engine and the amount of fuel it burns.

Do you check up occasionally to see if boilers are being washed out often enough, and that the work is being properly done?

Do you ever check up engines that are ready to go out to see that the cinder hopper slides have been properly put in place, that the front door has been bolted tight, and that the spark cleaning hole cap is firmly seated? You know, of course, how seriously the leaking of air into the front end affects the steaming of an engine, and, in addition, that air-leaks in the front end are liable to produce a burned and warped smokebox.

Do you ever study the problem of building fires in locomotives, not only from the viewpoint of seeing that there is a fire started that is in fit condition, so that the fireman can build it up ready for the run, but, in addition from the standpoint of the cost

of firing up engines, which is an important item, and can be cut down half at many points by improved methods?

Do you watch the way engines are coaled at the terminal, to see that the tanks are not filled too full and coal wasted thereby?

Do you examine the coal books on the engine from time to time? There are lots of cases where the coal book shows 23 or 24 tons of coal on a tank that can't possibly hold more than 15 or 16 tons. That is a thing that spoils the value of the performance sheets.

Do you ever stop and study the method of taking care of firing tools so that the fireman can have his own shovel and other tools? You know, of course, that any man can do cleaner, better work with the tool that he likes and that fits his hand than he can with a tool that does not suit him. There is economy in it from the store department standpoint, too.

Do you ever look over the engines at the roundhouse to see whether the decks are in proper condition, so the fireman can do good work? Sometimes there are strips of iron that stand up above the deck right where the fireman would naturally rest his foot. Sometimes there are bad places in the tank deck that catch a man's shovel and prevent him firing regularly. While you are looking at this, why not examine the doors to see if they latch properly, to see that they are properly equipped with chains, so that they can be swung shut easily between fires; or in the case of an automatic door-opener, that it is properly adjusted, and the pedal in a convenient position? All of these are things which make considerable difference in the amount of coal burned. I can remember trips, when I was firing, when I burned half a ton or more of coal too much, because the fire door would not latch open, and I could not fire the engine with any success going around curves nor very regularly on straight track. Poor door catches cost the railroad lots of money in coal wasted.

While you are up on the deck of the engine, do you look particularly to see whether the sheeting over the shaker levers is arranged so that there won't be a continual waste of coal through the holes at this point? If you haven't thought of this before, ride on one of these engines sometime, and you will be surprised to see how much coal will drop down through these holes and be wasted during the trip.

There are lots of other things to be seen around a roundhouse that time does not permit mentioning. Then, too, there are other things, such as getting engines properly drafted, testing for steam-pipe leaks, etc., that require more than ordinary inspection to locate and adjust.

#### ON THE ROAD.

When you are riding on the train do you take note of the smoke that is trailing back, or of the absence of such smoke, and commend the crew for good work at the end of the run? If the work was not good do you let them know that you noticed their poor work? Many times while you are riding back in the train you can hear the engine popping, and thus tell whether coal is being wasted in this manner. If you are riding on the engine there are many things to watch. You, of course, see how the fireman fires, what his method is, if he is getting the coal to burn, whether he is closing the door between each scoopful fired, whether he is slugging the engine, or firing light and even as he should, and, in fact, all of the different features of his work. If it is part of your duty, you will, of course, instruct, suggest or commend as the case may be.

There are other important features, however. Do you notice the location of the steam gage to see whether the fireman can see it easily? A badly located steam gage means coal wasted every trip. The same thing holds true to a less extent regarding the location of the water glass. You have undoubtedly watched the method of handling the injector, and you instruct, suggest or commend regarding this feature of the work, but are you sure that the engineer is co-operating with the fireman and the fireman with the engineer about steam and water, so that they understand each other's methods, and work together?

Do you watch to see if the fireman is using great big heaping scoopfuls of coal? If he is, you can suggest not filling the scoop so full, and he can probably do his work easier, and save considerable fuel.

Have you watched to see if he tears his fire all up with a rake? You might be able to convince him that he could get along much better if he fired more carefully and overcame the necessity of doing this raking. In a similar manner there is probably a whole lot of information you could give the fireman about shaking the grates, that would be of value to him and that would save considerable coal.

If the engine is popping, do you call attention to the unnecessary waste this is causing?

If a lot of black smoke is being made do you suggest improved methods that would overcome this bad feature?

When the engine is coming into a town where water or coal is to be taken, and the fireman puts in a "slug" to hold the fire while this is being done, thus smoking up the town, do you suggest to him that if he lined up the sides and corners and left a bright fire in the middle of the firebox he would avoid making all that smoke, and serve his purpose just as well?

Do you watch to see how the engineer handles the reverse lever and throttle, and do you watch to see whether the engineer gives the fireman warning before he is going to shut off, so as to save the last two or three scoopfuls of coal?

Are you giving the new fireman the amount of attention that he deserves? You know that if you let the new fireman watch some poor man he will learn poor methods and get into bad habits; whereas, if you can break in the new fireman yourself, or put him with a crew that you know will break him in properly, the new man will start out with proper ideas, and will give results accordingly. If you have watched this proposition of the new man you can't fail to realize the importance of the matter.

GENERAL.

Do you try to make your commendations somewhat publicly, that is in the hearing of other interested men, and your suggestions, and especially your first severe criticisms, as personal and confidential as possible?

If there is any tying up on the road, on account of the sixteen hour law, do you check up to see that the engine is being properly taken care of, and no coal wasted? In a similar manner are you in touch with the situation on helper engines, work train engines, steam shovels, pile drivers, etc.? Do you know where the steam shovel gets its coal? If it is getting it from the work-train engines, and proper account is not made of this fact, it interferes with your fuel showing. Then, too, a lot of coal may be wasted in helper service, work-train service, steam shovel or pile driver service, by firemen not properly banking their fires when the engines are not at work.

Do you ever drop off at pumping stations to see what kind of coal they are burning, what the conditions are at these points, and whether the coal is being used economically? At small expense the boiler plants at many pumping stations can be made

to burn the poorest grade of fuel with a considerable saving in cost. This is a point well worth looking after. It should be remembered, however, that the plant must be kept in condition to successfully burn the cheap coal, or else the pumper will get lump coal from engine tanks to keep his boiler hot.

Do you know anything about the distribution of coal for heating purposes at telegraph offices, stations, switch shanties, section houses, outfit cars, etc.? In many cases coal is thrown off from road engines or switch engines to supply such points. This makes a charge against your locomotive performance that should not be necessary. Coal storage facilities at such points is another feature worth looking into, to prevent coal being wasted or stolen.

When you get a report of poor coal or find poor coal on engines, cars, or at coal chutes, do you follow the matter up to get the car numbers, and to check up so that you will know what mine the coal came from? If you do this, it is then an easy matter to find out whether the coal was inspected, and to line things up so that further trouble can be avoided, temporarily at least.

Are you in touch with the division accountant who makes up the fuel statistics for the division, and has to make the final pencil adjustments as between coal furnished the division and charged out? He is a good man to know, and to keep in close touch with. You can help him, too.

Have you ever made a check to find out if the estimate of coal on hand on the division at the close of the month is a real estimate or merely a wild guess?

Do you know, with any degree of accuracy, your average cost of coal per day? If not, why don't you arrange with the division accountant so that you can have this information?

AN UNUSUAL SIGNAL INSTALLATION.

The celebration at Gettysburg battlefield July 1, 2 and 3 was the occasion of an enterprise in signaling never before heard of—the installation of automatic block signals for 25 miles, and the removal of the signals after the celebration was over; a costly temporary arrangement, but one which was warranted by the magnitude of the traffic. The Federal Signal Company, which furnished the signals, sends us the following account of the work:

"The fiftieth anniversary of the Battle of Gettysburg was celebrated by a reunion of the veterans of the North and South, and there were about 100,000 visitors at Gettysburg. Of this number about 70 per cent., or 70,000, were transported over the Gettysburg & Harrisburg Railroad of the Philadelphia & Reading system, a single-track line 25 miles long. In order to handle this heavy traffic expeditiously and safely, it was decided to make a temporary installation of automatic block signals. The regular traffic is so light that permanent automatic block signals were not warranted; ordinarily there are never two passenger trains on this section at the same time, there being but eight trains a day, four in each direction. The signals are the

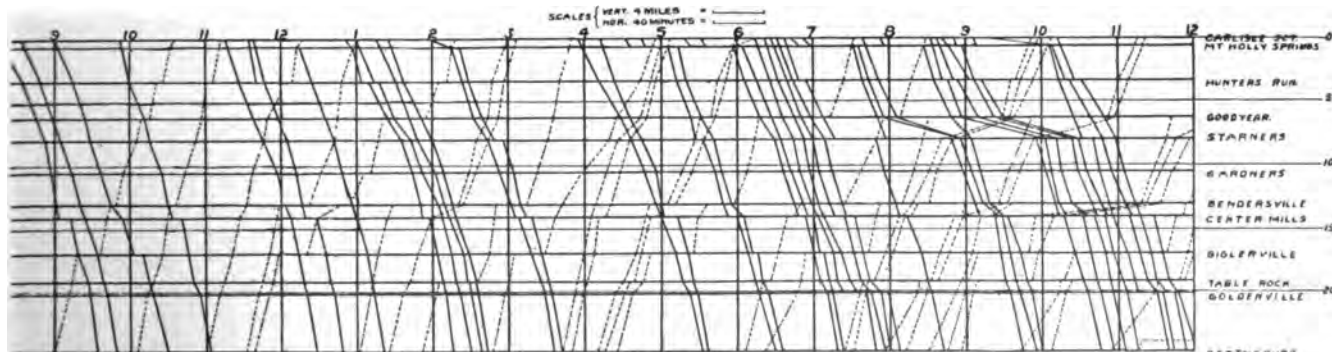

Fig. 2—Train Movements on the Gettysburg & Harrisburg Railroad June 30, 1913, from 9 a. m. to Midnight.



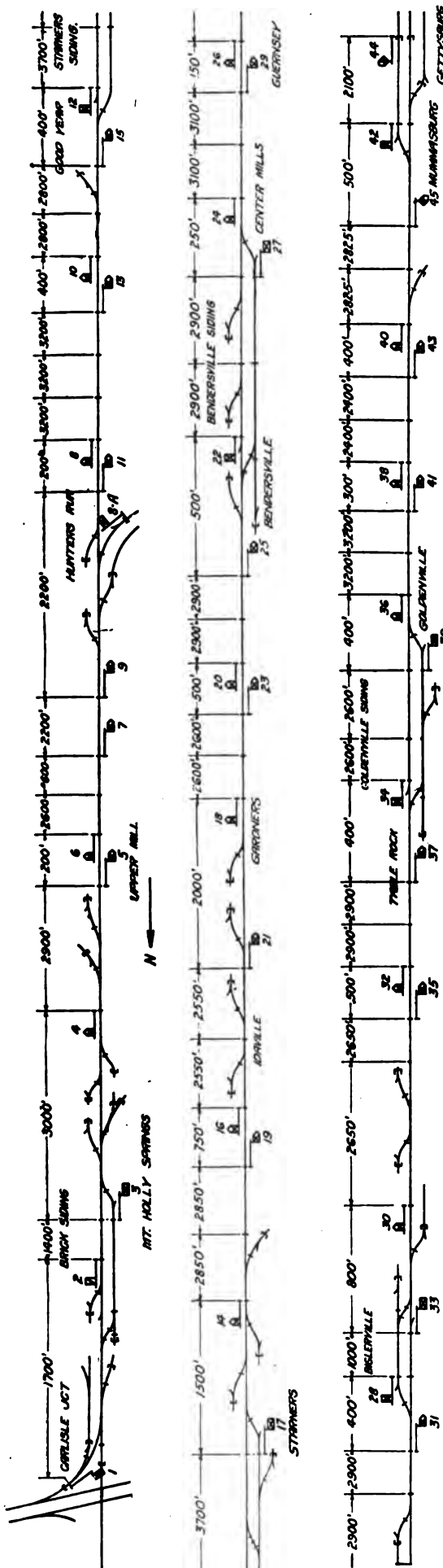

Fig. 1.—Switches and Temporary Automatic Block Signals on the Gettysburg & Harrisburg Railroad.

same as the Federal company is installing on the New York, Chicago & St. Louis between Payne, Ohio, and Stoney Island, Ill.

"The contract for the installation of the signals on the Gettysburg & Harrisburg was let April 8, 1913. Work was started May 1, and the signals were put in service June 22. They were taken out of service July 7. The signals were located as shown in the diagram, Fig. 1, and were of the three-position upper-quadrant type arranged to stand normally clear for trains in one direction, the signals governing opposite movements over the same track standing in the stop position.

"The switches were operated by switch stands. Derails were provided at ends of double track, mechanically connected to the switches. The signals were supported on long ties made firm by blocking. The signal and track batteries were placed in wood boxes on top of the ground."

The rails were bonded in accordance with the R. S. A. standard, but duplicate wires were not used. The line wires used were iron, covered with weatherproof insulation, and supported on porcelain knobs fastened to the sides of temporary poles.

Most of the traffic was handled between the hours of noon and midnight; and the total volume is indicated by the following table:

TRAINS BETWEEN HARRISBURG AND GETTYSBURG, JUNE 29—JULY 6, 1913.

Date.	Southward.		Northward.		Total.	
	Number of trains.	Average cars per train.	Number of trains.	Average cars per train.	Number of trains.	Average cars per train.
June 29.....	23	9	24	9	47	9
June 30.....	36	10	29	10	65	10
July 1.....	16	8	21	5	37	7
July 2.....	14	9	13	10	27	9
July 3.....	14	8	12	10	26	9
July 4.....	28	10	22	10	50	10
July 5.....	18	9	19	11	37	10
July 6.....	1	6	7	11	8	8
Summary....	19	9	18	9	37	9

We show in Fig. 2 a part of the diagram showing train movements June 30, when the traffic was nearly all southward. Southbound trains are indicated by solid, and northbound by dotted lines. The scales are such that 4 miles vertical is equal to 40 minutes horizontal. The passing track switches are set for southbound movements, Carlisle Junction to Gettysburg, and the signals are in corresponding positions.

Officers of the road expressed themselves as well satisfied with the service of the signals.

**AUTOMATIC BRAKES IN INDIA.**—During the calendar year 1912 350 engines, 697 passenger cars and 7,936 freight cars were fitted with automatic brakes, bringing the total number so fitted at the close of the year up to 6,063 engines, 18,159 passenger cars and 64,657 freight cars, as against 1,549 engines, 3,826 passenger cars and 92,004 freight cars not fitted.

**CONGESTION OF TRAFFIC IN INDIA.**—The special difficulty with which the Indian railways had to grapple during 1912, was the inability of the companies to deal promptly with all the traffic offered to them. The difficulty was especially acute in connection with the coal traffic. For the last six years the directors have been working on a policy of enlarging the capacity of the lines and increasing the rolling stock, and the very large increase in gross earnings and in tonnage carried in 1912 as compared with former years, indicates that the carrying capacity of the railways has been largely increased; but, at the same time, there is no doubt that for the time being trade in India has outstripped the transport facilities of the railways. Large orders for rolling stock have been placed and the program for additions to rolling stock during the present year is the largest in the history of Indian railways. Though the traffic carried during the cold weather of 1912 was even heavier than that of the corresponding period of the previous year, the congestion was far less acute and with a vigorous prosecution of the existing policy there are good grounds for belief that a marked and progressive improvement will be visible in each successive year.

# EXTENSIVE IMPROVEMENTS ON THE L. & N.

Interesting Features of the Bridge, Tunnel and Grading Work Now Under Way Between Paris, Ky., and Jackson.

The very heavy and extensive work which the Louisville & Nashville has under way between Nashville and Birmingham was described in the *Railway Age Gazette* of July 25. This company has another distinct project, which also involves some very heavy work, between Paris, Ky., and Jackson. This work is being undertaken in continuation of the policy of improving the line from Cincinnati to the coal fields at the head of the Kentucky river, which has been under way for some time. A second track has been completed from Cincinnati to Paris (see *Railway Age Gazette* of June 16, 1911, for a description of the enlargement of the Covington tunnel, which was one of the interesting features of this double track work), and at present this is being continued to Winchester. The work of improving the line from Winchester to Jackson is being pushed at present in anticipation of an early increase in coal traffic, which will follow the development of large tracts of land recently secured by

The old grade between Paris and Winchester was one per cent., so that the improvements on that section will make an important change in operating conditions. The revision work on this section involves some heavy grading and long hauls. The maximum departure from the old line is about one-half mile.

On the new line between Winchester and Irvine the earthwork is heavy for the entire distance. The line crosses the drainage almost all the way, paralleling the Kentucky river for a short distance before reaching Irvine, but crossing all the tributary streams. The line along the river is on a steep side hill and has occasioned a great deal of trouble on account of slides, the location being finally revised to throw the line further up the hill and reduce this trouble. A large percentage of the material on the northern end of this new line is rock, some of which is very hard blue slate. Deep cuts and fills are numerous and two or three contractors used cableways to very good advantage

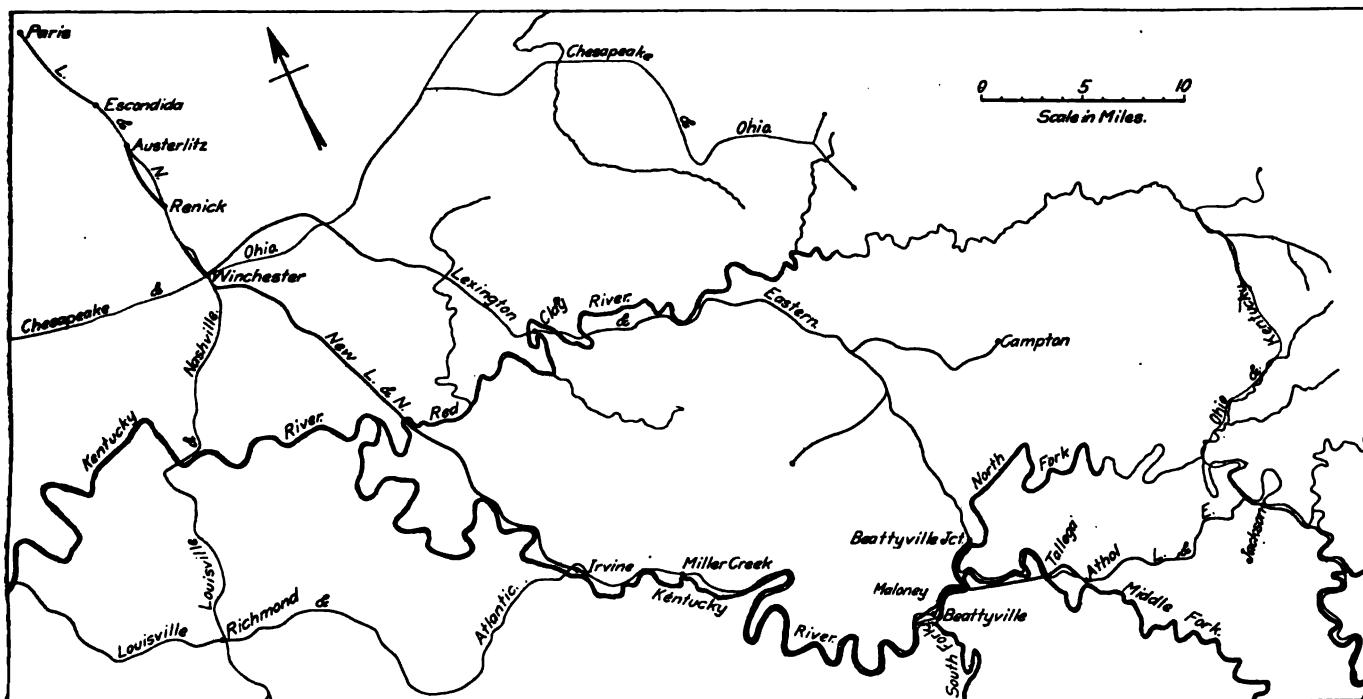

Map of the Louisville & Nashville Lines Between Paris, Ky., and Jackson.

a large mining company in the district at the head of the Kentucky river.

In addition to the double tracking between Paris and Winchester, the line is being revised and grades lowered. The Louisville & Nashville owns a line, the Lexington & Eastern, from Winchester to Jackson, but the location is not what was desired and it was decided to build from Winchester to Irvine, which is on the Louisville & Atlantic, also an L. & N. line, and to use that line from there to Maloney, following the Kentucky river. At that point the new line will cross the north fork of the Kentucky and follow the middle fork to Tallega where it will strike the present line of the L. & E. From there to Jackson the existing line will be used with necessary improvements. The grades on this line will be 0.3 per cent. northbound and 0.5 per cent. southbound, except between Winchester and Irvine where the grade is 0.4 per cent. As most of the traffic will be coal from the Jackson district to the northern markets, the former grades will be against the loads. The maximum curvature will be six degrees and the road bed standards will be 24 ft. in cuts and 18 ft. in fills.

in making the deep fills. One contractor, having two short cuts about 60 ft. deep, had considerable trouble in making the first shovel cut on account of the steepness of the approaches. As all the material had to be used it was necessary to put in two or more switch-backs to get the work trains down to the dumping trestle. There are two tunnels near the north end of the new section, both in rock, one of which, however, requires timbering. It is planned to line both of these tunnels with concrete. The approach cut and heading of the Conkwright tunnel, which is the larger of the two, is shown on one of the photographs.

There are a number of important bridges on this line, the largest of which is across the Red river. This structure is 1,780 ft. long, consisting of a steel viaduct with 13 40-ft. tower girder spans, seven 60-ft. and eight 80-ft. intermediate girder spans, and one 200-ft. deck truss. The maximum elevation of base of rail above the top of the pedestals is about 155 ft. The footings are spread on hard clay under 12 bents and are carried down to rock in the other cases. There are four other viaducts on this line, one over Howards Creek, 1,235 ft. long; one over Dry Fork, 460 ft.; one over Calloway Creek, 420 ft. and one other

360 ft. long. Both of the abutments for the 360 ft. structure and one at Howards Creek are of reinforced concrete of the pier type, described in a former article on the Cumberland River bridge. (See *Railway Age Gazette*, July 25, 1913, p. 153.)

Soundings at the site of the viaduct over Calloway Creek showed a depth of 40 to 50 ft. to rock, the overlying material being very unsatisfactory for footings as the bed of the creek

pedestal of 64 ft. 7 in. The pedestals under three bents are spread to 12 ft. square and are carried on nine reinforced concrete piles 14 in. square at the top and 12 in. square at the point, reaching to rock. The other footings are carried down to rock. The adoption of the viaduct for this location was also influenced by the fact that a road crossed the line near the creek which would have required a separate arch if an arch

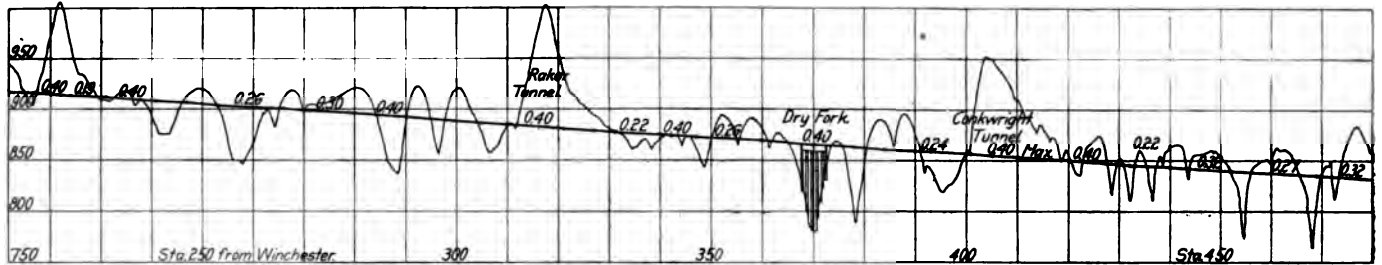

Portion of the Profile Between Winchester and Irvine.

has been filled up by deposits during high water in the Kentucky river. The creek empties into the river only a short distance below the crossing of the new line and since the building of dams in the river the high waters have repeatedly backed up

had been used for the creek, but which can now be carried under the viaduct without extra cost.

Most of the small stream openings are concrete arches. The largest of these is at White Oak Creek where a 52-ft. arch is



Making a High Fill with a Cableway.



Typical Culvert Construction.

into these tributary streams, depositing large quantities of drift-wood, vegetable matter and silt. The final plans for the viaduct show a maximum elevation of base of rail above the top of the

built. The footings are carried to rock, the footing below the springing line of the arch being about 8 ft. thick. The arch ring is not reinforced, being 6 ft. thick at the haunches and



Opening Up a Deep Cut.



Contractor's Plant for White Oak Creek Arch.

3 ft. 6 in. at the crown. This ring was placed in 10-ft. sections which was as much as could be finished in a day's work. Spandrel walls are 9 in. thick and the wing walls 6 in. to 8 in. thick, heavily reinforced and braced by counterforts 8 ft. to 10 ft., center to center. Stone for concrete was secured from a quarry

screenings, which has served to fill the crevices around the old piles and solidify the fill very satisfactorily. Crushed stone is being used for ballast on the revised line so that screenings are available at the crusher plant. The new roadbed is being laid with 90-lb. rail on oak ties.

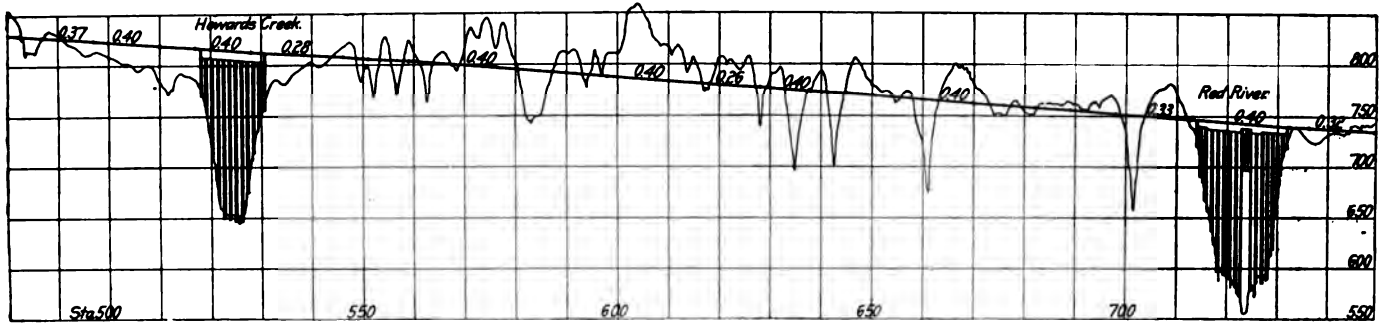

Portion of the Profile Between Winchester and Irvine.

near the site, as was also possible in a number of other cases on this section. A very good grade of stone was secured in this way. Screenings and river sand were used for the fine aggregate. The plant for placing the White Oak Creek arch is shown in one of the photographs. In another is shown a 14-ft. and 16-ft. arch near the north end of the line, one carrying the arch and one the creek.

At Irvine a comparatively large yard is being built as a distributing and collecting yard to serve the mine district and to

In two cases on this section unusual conditions were encountered in building concrete culverts. In one case it was found that the rock on which the culvert was designed to be founded ran out about under the middle of the culvert and as the masonry work was then holding up grading there was no time to change the design or relocate the structure. As no pile driver was available it was impossible to drive piles under the footing and after a number of plans had been discussed and discarded it was decided to drive 6-ft. well casings 12 ft. long, 8 ft. center to center, remove the material inside the casings with a well auger and fill them with concrete, thus forming concrete piles. The casings were driven by heavy blocks, pulled up by hand and all tools necessary were easily secured locally. In the other case a road crossed the line near a small stream and a double deck



Footings and Abutment for Dry Fork Viaduct.

classify the loads for road trains. It will be a flat yard with provision for increasing the capacity as needed.

From Irvine to Maloney the revision work is light, consisting largely of eliminating curvature and raising the line in places to keep above high water. All of the old trestles, of which there were a large number, are being filled. To decrease the settling on these new fills, which has been very troublesome, the plan was adopted of covering the top of the fill with a layer of fine



North Heading of Conkwright Tunnel.

concrete box design was adopted which carries the stream in a waterway 6 ft. 6 in. x 12 ft. and the roadway overhead in an opening 12 ft. x 13 ft. The roadway opening is 58 ft. 6 in. shorter than the waterway, allowing room at both ends for the roadway to turn off of the floor of the box to an approach built alongside the stream. Wing walls are provided to keep the fill from encroaching on these highway approaches. The entire structure is heavily reinforced, as shown in the drawings.

The material handled in the work between Irvine and Maloney is largely shale which disintegrates rapidly. In many cases a shelf of material resembling fireclay cropped out and in such cases slides almost invariably occurred. More than 50,000 yds. of material have been removed from slides on this section.

The new line leaves the L. & A. at Maloney, crossing the

north fork on a bridge consisting of one 250-ft. through truss, one 40-ft. and two 80-ft. deck plate girders. The new line to Tallega follows the middle fork, except at one point where the river makes a big bend and the line cuts through in a tunnel. Between Tallega and Athol the principal feature of the work is the construction of a new tunnel replacing one on the old line known as Mud tunnel. The old one was in a very soft material and caused endless trouble when it was driven, by caving, sliding and crushing the timbers. As the new grade is about 40 ft. below the old at this point the new tunnel strikes much better material, a large part of which is slate and no difficulty is expected.

In replacing an old deck truss bridge near Athol with a concrete arch the fill could not be carried above the lower chord for fear of weakening the truss and causing a failure. It was necessary to place temporary bents on the new fill while the bottom chord was removed and the fill completed.

The work from Athol to Jackson consists principally of improving the existing line by the application of stone ballast and heavier rails and is being handled entirely by company forces.

This work is being handled under a special construction de-

**SAFETY EXHIBIT CAR.**

Early last week a safety exhibit car was put in service on the New York Central & Hudson River at the Grand Central Terminal station in New York, which contains a large number of models showing how the various machines used in a railroad shop should be properly safeguarded, together with a number of photographs showing various machine guards and safety appliances, as well as a large number of photographs relating to the trespass problem. The first two days that the car was open 600 men visited it. The car will be taken over the entire New York Central system, visiting first the more important division and terminal points and later covering the smaller places. Every employee will be required to visit the car, and lectures will be given at regular intervals in another special car arranged for this purpose which will accompany the exhibit car.

The exhibit car was constructed from a standard baggage car, is finished in white enamel and has a floor covering of linoleum. Along both sides, about 3 ft. from the floor, is a shelf which is finished in mahogany and on which the various models are placed. On the side walls, a couple of feet above the shelf, is a

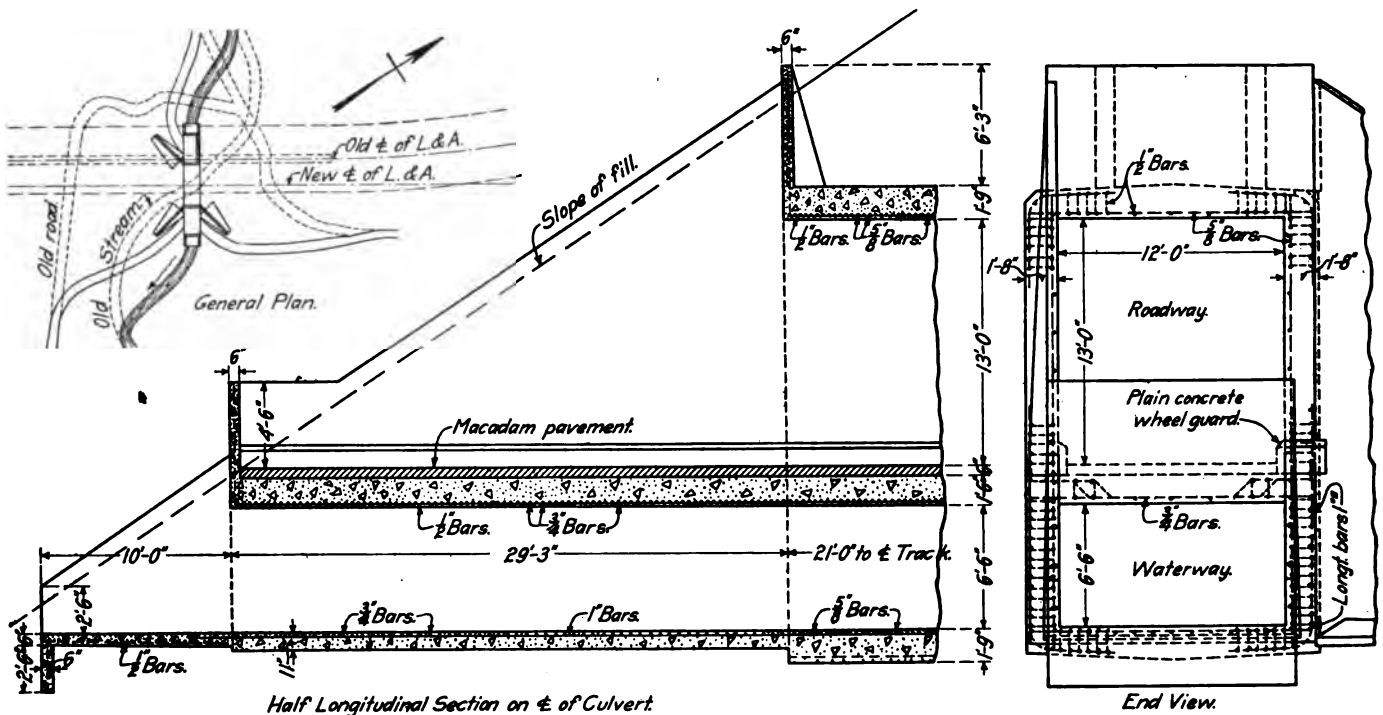

**Details of Double Deck Concrete Culvert.**

partment, which, as mentioned in the former article, has been organized under the direction of John Howe Peyton, assistant to the president and chief engineer of construction. H. G. Laird is in charge of the work between DeCoursey, Ky., and Winchester, and Ewing D. Sloan is in charge of the work between Winchester and Jackson. The work was let in nine general contracts. We are indebted both to the engineers and contractors connected with the work for courtesies extended in securing the above information.

**RAILWAY PROSPERITY IN SPAIN.**—The railways of the country are progressing rapidly, as evidenced by the fact that in 1911 railway material was purchased abroad to the value of \$4,734,000, and the state revenue from taxes on passenger and freight traffic was \$4,742,000. The railroad receipts increased from \$57,060,000 in 1911 to \$62,422,380 in 1912. The increase in freight traffic has been such that in 1912 over 2,000 freight cars were constructed in the two Spanish workshops, besides the imports of rolling stock from abroad.

double row of neatly arranged photographs. On one side of the car are a number of photographs which show unsafe practices which commonly cause accidents resulting in injuries to the employees and others. Alongside of each picture is another one showing the safe practice which if it had been followed would have prevented the accident. This collection of photos is based on those causes which statistics covering the past two years show to have been the most prolific sources of accidents.

Another part of the side wall is devoted to a number of pictures showing how trespassers needlessly risk their lives, and above these is a statement calling attention to the fact that during the year ending June 30, 1912, there were 5,284 persons killed and 5,687 injured while trespassing on railroads in the United States. As the car is taken over the system it is expected that a number of magistrates and local public authorities will visit it, and their attention will be especially directed to this part of the exhibit. At the same time they will also be furnished with literature giving statistics on trespassing, with the idea that they will be encouraged to take a greater interest in preventing this abuse.

The models which are shown cover safeguards to shop machinery and also include water gage glasses of an approved and safe type, and models showing the proper way of applying railings to engine house turntables and to transfer tables; also of safeguarding stairways. There are a number of signs in the car which are intended to catch the visitor's eye and emphasize certain facts in connection with safety first. Among these are the following:

- "It pays to do your work the safe way."
- "The most important machine is man—Get the safety habit."
- "Thirteen thousand miles of railroads—150,000 employees—We aim to make them all safe."
- "Statistics show that by far the greater number of injuries are caused by unsafe practices on the part of employees."
- "During the first four months of 1913 on the N. Y. C. & H. R. and L. S. & M. S. roads there were 35 fewer employees killed on duty than during the same period of 1912. Conclusive proof that safety work is a benefit to the employees and their families."

The above showing is a remarkable one when it is known that the locomotive mileage increased 2 per cent. on the New York

Central and 8 per cent. on the Lake Shore, as compared to the same period for the previous year. This splendid showing is largely due to the energetic work of the safety department. There are now 60 division safety committees on the New York Central Lines, including 900 men. These committees consist of certain division officers and men from the ranks who represent each branch of the service. The men each serve six months and are then succeeded by other members. The old committeemen, however, retain their safety buttons and have the authority to cooperate with the safety committee in calling attention to and eliminating unsafe practices.

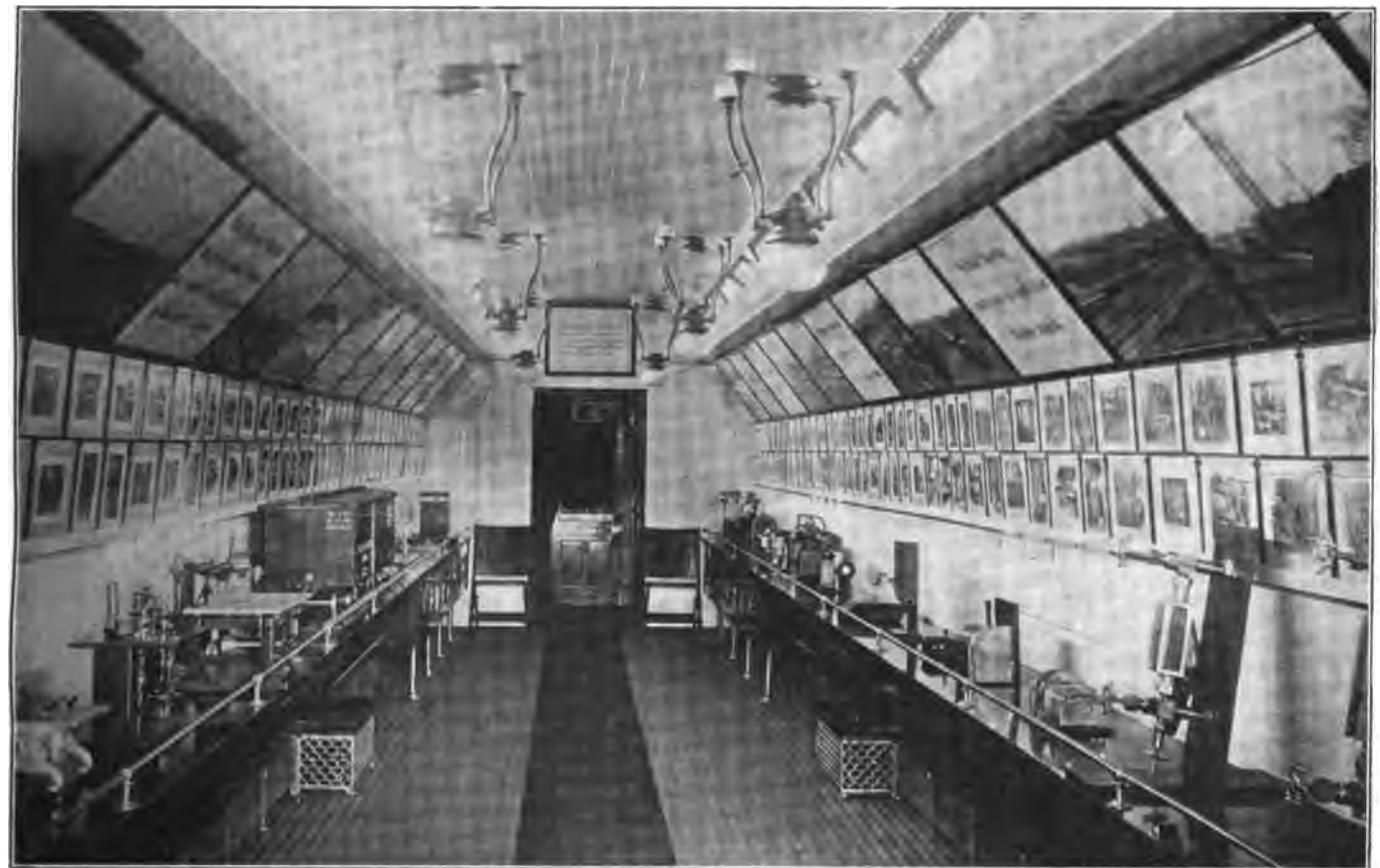

Interior of Safety Exhibit Car; New York Central Lines.

The lockers shown underneath the shelves at the far end of the car are intended to carry literature which will be distributed to the men. This will include safety bulletins and copies of the *Safety Magazine*. The men in charge of the car will also have copies of the safety standards of the New York Central Lines, which contain specifications profusely illustrated, showing ex-

actly how different classes of machinery should be safeguarded. The car was equipped and will be operated under the direction of M. A. Dow, general safety agent of the New York Central Lines.

**RAILWAY COKE FACTORY IN MANCHURIA.**—The South Manchuria railway gas department is constructing a coke factory at the Fushun collieries. The building has been completed and the kilns and machinery are now being installed. The new factory will be ready early in August at the latest. There are to be five kilns, each capable of treating ten tons of coal at one time, installed in a row, to be used one after another. When completed the daily average output of coke will be about 35 tons.

**AMUR RAILROAD, MANCHURIA.**—With a view of shortening the distance between the line of the Amur railroad and the Pacific ocean, the construction committee of the railway has under consideration two branch lines, one from Khabanofsk to

Imperial harbor, and the other from Shmakovka, a station on the Ussuri railroad 316 miles north of Vladivostok, to St. Olga bay. The cost of surveys is estimated at \$38,625 and \$30,900, respectively, and these sums were included in the railroad budget for 1914.

**RAILWAY EXTENSION IN INDIA.**—Permission having been obtained from the government, a commencement was made during the year by the Delhi railway with the extension of its line from Tebing Tinggi, the present terminus, to the port of Tandjong Balei. It is anticipated that on the completion of the first section the Delhi railway will undertake the construction of a side line to Siantar, through the Simeloengoen district, which district is being rapidly developed for rubber and tea cultivation. In view of the increasing trade of the port of Belawan, the Delhi railway has at present under consideration a proposal to double the line from Belawan to Medan.

PRINCIPLES OF ELECTRIC RAILROADING\*.

BY C. L. DE MURALT,

Professor of Electrical Engineering, University of Michigan.

III.

In the last article of this series (*Railway Age Gazette*, May 9, 1913), we established the following formulas for use in calculating the force which it takes to move a railroad train under any given set of conditions:

To overcome the force of inertia, that is to say, to start a train from rest, or to stop a running train, it requires

$$f_i = 100 W A \text{ pounds,} \tag{1}$$

where  $W$  represents the weight of the train in tons and  $A$  the rate of acceleration, or retardation, in miles per hour per second.

To lift a train up a grade against the force of gravity, it takes a force

$$f_g = 20 W p \text{ pounds,} \tag{2}$$

where  $p$  represents the grade in per cent. (feet rise per 100 ft. horizontal length).

And to overcome train friction it takes a force

$$f_r = W \left( 2 + \frac{V}{10} + \frac{90}{W'} \right) \text{ pounds,} \tag{3}$$

where  $V$  stands for the train speed in miles per hour, and  $W'$  for the average weight per car in tons. To this amount must be added, in the case of uncompensated curves, an amount equal to  $0.7 W$  for every degree of curvature.

TRACTIVE EFFORT.

The sum of these three forces constitutes what is generally called "tractive effort," namely the total effort or force which the engine must exert to move the train.

Let the tractive effort be represented by  $f$ , then we may write:

$$f = f_i + f_g + f_r \\ = 100 W A + 20 W p + W \left( 2 + \frac{V}{10} + \frac{90}{W'} \right)$$

$$\text{or, } f = W \left( 2 + 0.1 V + \frac{90}{W'} + 100 A + 20 p \right) \tag{4}$$

where  $f$  is the total tractive effort in pounds, if  $W$  is the weight of train in tons,  $V$  the speed in miles per hour,  $W'$  the average weight per car in tons,  $A$  the rate of acceleration in miles per hour per second, and  $p$  the grade in per cent.

This force  $f$  must be exerted whether the motive power is steam or electricity, and whether the train is a motor car train or a train drawn by a separate locomotive. Not all the factors shown in the formula are necessarily present at all times. For instance, during a start on the level,  $p$  will equal zero, and the last item of the formula will consequently be made to disappear. On the other hand, during a run at constant speed,  $A$  will equal zero and the second item from the end will disappear. It is therefore necessary to consider what values attach to each of the factors of the formula at every point along the road, and in that way we may establish the value for the tractive effort at every single point.

WEIGHT ON DRIVERS.

The next point to consider is, how is this tractive effort going to be produced and applied. In this connection we might as well realize that in practically all instances, the force necessary to move the train is developed within the train itself. The only exception which at once suggests itself to our mind is the case of the inclined cable railway, where the necessary tractive effort is produced by some outside machinery and is transmitted to the cars by means of the cable. In practically all other cases we have some kind of an engine, be it a steam engine, or an electric motor, or a gasolene engine, or an alcohol engine, or what not, which is placed in some part of the train and is connected to one or more of the axles of the train in such a manner as to make them revolve. The fact that these axles,

through the wheels, are resting on the track, makes the train roll forward when the axles are turned.

Right here is where the importance of the weight on drivers comes in. It is through the contact between wheel and rail that the revolving motion of the axle is changed into a forward motion of the train as a whole. This can only take place if the contact between wheel and rail is good. If it is bad, that is to say, if the wheels slip on the rails, then the engine may still turn the axles but the train will not move forward.

The quality of the contact depends mainly upon two things, namely, upon the condition of the surfaces of wheel and rail, and upon the pressure with which the two are held together. As to the first, we all know that wet rails, or rails covered with sleet or snow, will let the wheels slip more readily, while clean dry rails, or sanded rails, will hold them. As to the second, the more pressure we exert on the contact surface, that is to say, the more weight we put over the driving axle, the greater will be the effort which we can transmit without letting the wheels slip. In practice this is generally expressed in a formula about as follows:

$$f_{max} = x w''$$

where  $f_{max}$  represents the maximum tractive effort in pounds which can be transmitted without slipping the wheels, if  $w''$  stands for the weight on drivers in pounds, and  $x$  is the so-called "co-efficient of adhesion." The actual values of the latter are approximately as follows:

For clean dry rail.....	0.3
For wet rail.....	0.18
For rail covered with sleet or snow.....	0.1
For sanded rail.....	0.22

Inasmuch as all modern motive power is equipped with sanding devices, it has become customary to use the standard value for  $x = 0.22$ . With electric locomotives or electric motor cars it would be permissible to raise this to  $x = 0.25$ , because the torque exerted by an electric motor is perfectly uniform, whereas the torque exerted by a steam engine or gasolene engine fluctuates during one revolution between a maximum and a minimum value, so that the average value is less than its maximum value. As a matter of fact, tests with electric locomotives on clean dry rails have resulted in values as high as  $x = 0.4$ . But for the purposes of this treatise we will disregard this difference and assume uniformly  $x = 0.22$ , whether the motive power be steam or electricity or gasolene. The above formula thus becomes:

$$f_{max} = 0.22 w'' \tag{5}$$

And if we turn this around, we get:

$$w'' = \frac{f_{max}}{0.22} \tag{6}$$

which enables us to determine the weight, in pounds, which must be placed on drivers if it is desired to develop a certain maximum tractive effort.

For any given train operating under certain conditions we can find the necessary maximum tractive effort by means of formula (4) above. If this value is inserted in formula (6), then we obtain the minimum weight which must be placed on drivers in order to move the train under these conditions. We will see later that certain systems of motive power can get along with this minimum weight on drivers, while others, in order to develop the necessary horse power, must have additional weight. It will be best, however, to postpone this part of the investigation until after we will have defined the term horse power as applied to railroad work, which we will do in the next article. Meanwhile it will be interesting to note which are the principal factors that influence the minimum weight on drivers.

If we look at formula (4) we see that there are two items which more than any of the others affect the value of  $f$ , namely the items "100 A" and "20 p." If either  $A$  or  $p$  is increased, even by a small amount, the resultant change in  $f$  is marked, and is greater than would be produced by a much greater proportionate increase of either of the other variables, for instance  $V$ . Expressed in words this means that the tractive ef-

\*Copyright, 1913, by the Simmons-Boardman Publishing Company.

fort, and with it the required weight on drivers, will be seriously increased by any material increase in rate of acceleration or by any material steepening of the grade.

In ordinary trunk line no very great rates of acceleration are required. The weight on drivers found in ordinary locomotives is quite sufficient for the purpose. In suburban service in the neighborhood of the big cities, matters are changed, however. In order to make reasonable schedule speed with stops from one to two miles apart or less, it is necessary that trains get under way as fast as possible. This means that the rate of acceleration is pushed up and with it, up goes the tractive effort required and the weight on drivers. We generally find that the first step taken to meet this condition is the development of some special type of suburban locomotives with an exceptional amount of weight on drivers. But there are cases where this is not sufficient. In real rapid transit work rates of acceleration of 2 miles per hour per second and more are not uncommon. To start a train of say 300 tons at this rate will, according to formula (1), require for starting effort alone a force of

$$f_1 = 100 \times 300 \times 2 = 60,000 \text{ lbs.,}$$

to which must be added the effort necessary to overcome friction and grade. And, according to formula (6), the minimum weight on drivers corresponding to this force is

$$w'' = \frac{60,000}{0.22} = 273,000 \text{ lbs.}$$

To place such values in high speed passenger locomotives is not easy, and the difficulty is increased with every increase in train weight and rate of acceleration. The problem is solved by substituting motor cars for locomotives. Instead of concentrating our motive power on from two to four axles of the locomotive, we distribute it throughout the train over as many axles as necessary, and in that way we have no difficulty in placing as much weight on drivers as may be called for by the highest feasible rates of acceleration.

This is the reason why suburban service is best handled by motor car trains. And it explains how such lines as the Manhattan Elevated, or the New York Central, were able to materially increase their schedule speed when they supplanted their steam locomotives by electric motor cars.

The effect of increase of grade on weight on drivers is somewhat different. It is particularly noticeable in heavy freight service. On the level or on low grades we find ordinary locomotives quite heavy enough to haul even the heaviest of trains. When it comes to grades in the neighborhood of 2 per cent. and above, things are different. To run a train of say 2,000 tons up a grade of 3 per cent. will, according to formula (2), require for the overcoming of the grade alone a force of

$$f_g = 20 \times 2,000 \times 3 = 120,000 \text{ lbs.,}$$

to which must be added the effort necessary to overcome friction. The minimum weight on drivers, corresponding to this force, is according to formula (6)

$$w'' = \frac{120,000}{0.22} = 546,000 \text{ lbs.}$$

Values of this order cannot readily be placed in an ordinary locomotive, nor for that matter in a locomotive of the Mallet articulated type. The use of individual electric motors under freight cars has not yet been seriously suggested. Thus we find service of this nature handled by double heading or the use of pusher locomotives in steam operation, and by multiple unit locomotives in electric work.

It is well to thoroughly realize that in both of the cases cited above, the question of speed and the question of power of the engine or motor did not enter. It was merely a question of weight on the drivers in order to be able to give the required tractive effort. In the first instance the increased weight on drivers was required in order to give a satisfactory rate of acceleration, in the second instance in order to overcome an extra steep grade. The questions connected with speed and horse power will be taken up in the next article.

## NEW END CONSTRUCTION FOR PULLMAN CARS.

From a study of recent wrecks of passenger cars it has become apparent to the Pullman Company that a much more substantial end construction for both wooden and steel equipment is necessary to better withstand the shearing effect that a heavy steel underframe of one car has upon the superstructure of another car when this underframe laps over that of the car ahead in a collision. As a means to greatly reduce, if not to wholly eliminate the destructive effects in such cases, this company has adopted a new type of end construction which is shown in the illustrations. This design is the invention of Richmond Dean,

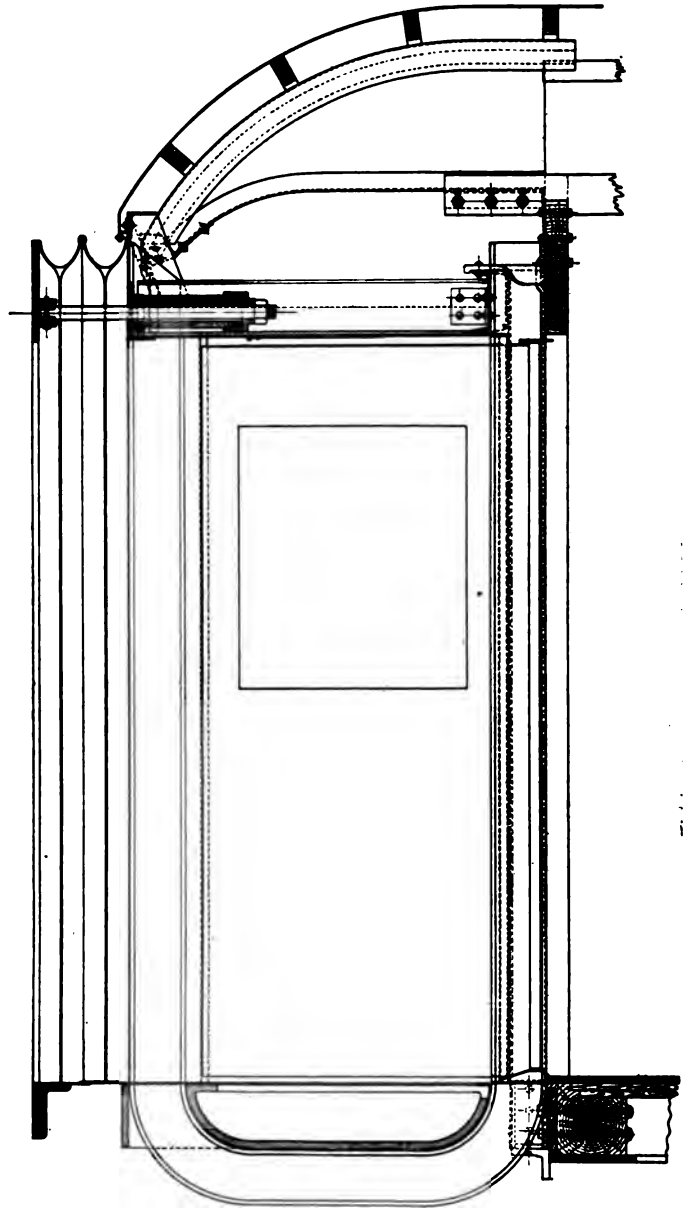

Side Elevation of U-Shaped Member In Pullman End Construction.

general manager of the Pullman Company. All of the modern Pullman equipment is provided with the Commonwealth steel underframe, which has a cast steel combined platform and double body bolster at each end. This underframe readily permits of the new end construction in combination with which a very efficient arrangement is obtained.

The principal feature of the new design is that of an I-beam bent in the form of a U, the legs of which extend upward through apertures in the platform casting. The upper ends of



these I-beams are thoroughly anchored in an end superstructure made up of structural shapes. Two of these U-shaped I-beams



New End Construction for Both Steel and Wooden Cars.

at the platform end sills. The U-shaped members are made from one continuous I-beam instead of being made up of riveted sections, in order to eliminate any possibility of riveted joints failing. With this construction it is readily seen that in case of collision, should one underframe override that of the next car, its progress will first be obstructed by the legs of the U-beam at the bumper sill, which as they bend will tend to lift the whole car body, thereby offering greater resistance to further advance of the overriding car. If these should fail there would still be the second leg of the U-shaped member, together with the strengthened car end, to further retard the progress of the overriding underframe. From a study of the design it will be seen that this construction is most substantial, and it would seem that it would fully accomplish the results desired.

This new car end is being applied to all new Pullman cars and to all high class wooden cars as they pass through the shops for general repairs. Mr. Dean in his patent claims states that unduly strong underframes, instead of affording the presumed advantages of safety to passengers and of preserving the cars from injury, may, at least in some instances, contribute to the damage of the latter, especially when the force of the collision is sufficient to cause the overriding of the underframes, resulting in the breaking down of the end wall of the car. It is his idea to remove the surplus strength from the underframe and so construct and strengthen the vestibule, as described above, that it will act as a cushion to absorb and dissipate the force of the impact of such a collision without materially increasing the weight of the car. Throughout the construction it has been his idea to reduce the number of riveted joints to a minimum.

The new car body end wall is securely fastened to the cast steel combined platform and double body bolster, and is made up of Z-bar end posts extending to the top of the roof, and secured to the other parts of the car framing in the usual manner. The outer faces of these posts are riveted to a channel sill above the doorway, which is bent to allow for the rear legs of the heavy U-shaped I-beams; the remainder of the vestibule is constructed to harmonize with the new features. It is believed that

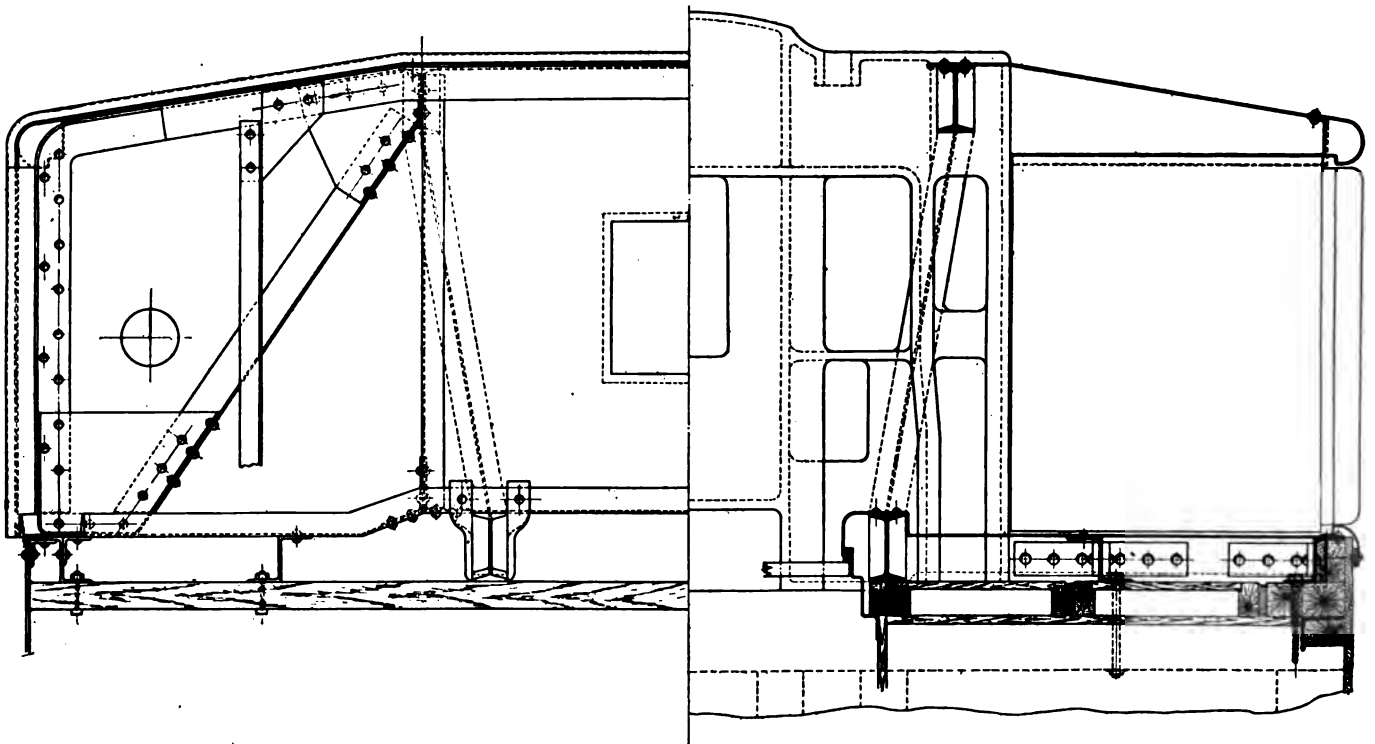

Top and Floor Plans of New End Construction for Pullman Cars.

are applied on each end of the car in the manner shown, one leg forming the door post at the entrance of the car, while the other forms the door post for the opening between the cars

this new design will be the means of preventing the disastrous results that have been recently experienced with the ordinary type of end construction in collisions.

# DECISION IN THE EXPRESS RATE CASES.\*

Interstate Commerce Commission Orders Lower Rates—Reductions Hit Long-Haul Traffic—Opinion by Commissioner Marble.

On June 8, 1912, a report and order of the commission, written by Commissioner Lane, was issued in the above matters. That report was abstracted in the *Railway Age Gazette* of July 19, 1912, page 99.

With regard to the requirements contained in that order the present situation is as follows:

The carriers on the day appointed, September 1, 1912, adopted the combined waybill and label, and the practices relative thereto as prescribed in the commission's report. It now appears that the requirement that a label shall be affixed to each package in a shipment of perishable property comprising a number of packages operates at some points to retard prompt movement. The order herein will provide that a label need be attached to only one package in each such shipment, such label to indicate the number of packages in the shipment.

The proposed Directory of Express Stations has been prepared by the carriers and is in type ready for issuance as soon as the final order as to rates shall be made. The failure of the carriers to issue this directory on December 1 followed a request by them to this commission for delay and acquiescence in such request by the commission. The order herein will provide that such directory shall be issued not later than October 15, 1913, the date hereinafter fixed for the application of the block system of stating rates and the new rates herein prescribed.

With regard to the third portion of the order of June 8, 1912, in which it was required that through routes should be established and published, the express companies suggested that the number of indirect routes is so large that the publication thereof in a tariff would be unduly burdensome without corresponding advantages to shippers. On November 30, 1912, therefore, the commission issued an order in this regard as follows:

That the respondents, and each of them, are required to immediately appoint a representative who together with a representative of the Interstate Commerce Commission hereafter to be named shall constitute a committee to be known as the Direct Routing Committee, the duties of which board shall be to study existing express routes and consider all complaints of indirect or circuitous routing and proposed amendments to the existing routes of express carriers so as to give to shippers the advantage of the most direct normal route in point of time.

This committee has been named. Its labors may be expected to minimize the evil of indirect routing which in the past has operated to deprive shippers of the despatch which should be a feature of the express business. In any case where reasonably expeditious through routes do not result from the conferences of this committee the commission has ample authority to prescribe new and reasonably direct through routes.

The block system of stating rates is admitted by the carriers to be practicable and satisfactory. By its simplicity and intelligibility, it will afford the means for such a statement of express rates as will really publish them to shippers. The order herein will therefore prescribe such block system of stating rates as the reasonable practice to be followed by the respondent carriers on and after October 15, 1913.

An informal joint committee representing respondent carriers and the complaining shippers has cooperated in suggestions for a new classification of property for express transportation. The resulting classification is fairly made and reasonable.

The classification above mentioned includes also new rules governing the practices of express companies which are so revised, simplified, and amended that they are just and reasonable.

In the report of June 8, 1912, it was found that the form of receipt for property issued by the respondent carriers was so worded as to improperly limit the rights of the shippers there-

under and to discourage the presentation of claims by the shippers whose consignments had been lost or damaged in transit. One of the matters considered by the informal joint committee above mentioned in connection with the new classification was a proposed new form of express receipt. All of the respondent carriers represented in this committee agreed that the form of express receipt determined by that committee is just and reasonable. The Adams Express Company has since withdrawn its agreement on this point.

This form provides that the liability of the carrier shall be limited to a maximum of \$50 on each shipment weighing less than 100 lbs., and to a maximum of 50 cents per pound on shipments weighing more than 100 lbs., unless a greater value is declared at the time of shipment. The rates prescribed are intended to cover the movement of the great mass of merchandise of moderate value. The classification prescribed provides for valuation charges upon articles of higher value. In the case of shipments of extraordinary value, not only is the carrier entitled to notice of such value in order that its care may be increased, but it is also entitled to extra compensation for the increased liability and care. Under the law it is the duty of shippers of property of more than ordinary value to bill the same at its true value in order that the legal rate may be applied. In the case of a shipper declaring a false value to secure a reduced rate one of the penalties under this form of receipt is an estoppel by which he is precluded, in case of loss or damage, from denying the correctness of such value so given.

The respondent carriers will be required to use the new express receipt exclusively in connection with all interstate shipments on and after October 15, 1913.

It has been suggested on behalf of these carriers that the amount of any c. o. d. bill for collection from a consignee shall be considered as a declaration of the value of the shipment, unless a greater value is declared. Such a provision seems to be a reasonable measure of protection to the carriers which they may adopt if they are so inclined.

From the foregoing it appears that serious controversy in this matter now exists only as to the amounts of the various rates to be applied under the block system.

The respondents have raised the contention that no order can be made concerning their schedules of rates as a whole, for the reason that the commission can not act except after hearing. To the rule relied upon the commission gives complete adherence. It does not follow, however, that in dealing with the rates of express companies, which are intimately related one to another, the commission must institute a separate investigation as to each rate. Stated in its extreme form, such a view would lead to the conclusion that express companies are outside the act. Each company has some millions of rates. Time would not be long enough to institute a separate investigation as to each of these. But the first fact developed by this investigation was that the rate scales of these respondents must be studied as a whole if justice is to be done to the express carriers or to the public. This investigation started with the consideration of single rates.

A petition was also filed on behalf of commercial organizations representing 212 of the largest cities of 42 states. Although specific rates were not named in this petition, the complaint involved the reasonableness of all the rates between these cities, and necessarily included the rates between them and the points intermediate to them upon all routes.

As a result of its investigation, the commission was convinced that its order must take into account the entire body of rates for express service. In this respect the express service is radically different from the services performed by the railroads in the carriage of passengers and property, and is more precisely

\*Though the opinion has been very much condensed, the original language is preserved insofar as is possible.

comparable with the service performed for the public by the Post Office department. No rate prescribed in the order has been made without an investigation and a hearing. The rates determined by the commission to be reasonable and just have also followed a like exhaustive investigation, and also have been in detail submitted to the analysis and criticism of the respondents and of shippers throughout the country for a period of several months. Having determined after investigation, as it did, that justice as to express rates could be reached only by the form of order adopted, and having submitted every detail of that order, not only to its own exhaustive analysis, but also to the analysis and criticism of the respondents and the shippers of the country, it is apparent that the fullest possible hearing has been given as to all the rates shown.

The long delay in the issuance of the commission's order as to the rates requires explanation. It has arisen from the extraordinary care exercised by the commission to make its order entirely fair to the express carriers.

Prolonged informal conferences between the commission and the executive heads of the respondents, including traffic officers and counsel, were held in the endeavor to arrive at a common understanding of the various problems involved, but the results were far from satisfactory and the conferences were discontinued.

The commission returned to its ordinary procedure in rate cases and itself formulated and published the rates embodied in its report of June 8, 1912. That order required the respondents to show why certain rates fixed by the commission were not reasonable. By this method it was hoped that every valid objection to the rates made by the commission might be developed, and that all changes necessary to make them entirely just might be made.

The rates for express transportation between various points in the United States contained in the order of June 8, 1912, were typical and representative of all the rates here prescribed. At various times between that date and December 10, 1912, additional proposed rates in harmony with those contained in the report were served upon the respondent carriers, with an order that they also be considered in the same manner as those contained in the report. These rates taken together constitute a system of express rates between all of the blocks served by the respondents herein. This system of rates as an entirety was used by the carriers in the returns made by them which are hereinafter discussed.

On October 9, 1912, the respondents appeared and pleaded that the rates proposed by the commission were unduly low. It was claimed that the rates furnished by the commission had been applied to the actual business of the respondents, and that the resulting figures indicated a reduction in gross revenues of more than 30 per cent. This statement was utterly inconsistent with the results of the comparisons of its proposed rates with the existing rates of the companies which had theretofore been made by the commission. It was also inconsistent with the estimates made by the commission of the effect of its rates upon the actual business of two companies for single days which had theretofore been reported to the commission.

The express companies admitted at this argument, however, that the showing which they were able to make at that time as to the effect of the rates as applied to actual business was incomplete and unsatisfactory. They asked for and were given further time to complete and correct their estimates.

The commission, desiring that there should be uniformity in the presentation of the figures developed by the respondents, issued, on December 10, 1912, an order prescribing in detail the forms to be used in presenting the same. By this order the express companies were required to answer certain specific inquiries and to support their answers with sufficient detail to enable the commission to verify the results.

The responses of the express companies to this order all purport to cover the business of October 23, 1912, and not the business of the days in 1911, which was made the basis of the argu-

ment on October 9, 1912. Certain abnormalities in the business of October 23, 1912, hereinafter described, indicate that larger claims of loss from the proposed rates may be made upon the basis of the business of that day than would be possible upon the basis of the business of a normal day. Five of the respondents filed their working sheets and primary detail papers. The following is compiled therefrom:

Statement showing the ratio of reduced revenue on interstate shipments to gross revenue from all sources for October 23, 1912, including revenue from transportation of money and valuables.

Express companies.	Reduction of revenue from—		
	Interstate merchandise shipments. Per cent.	Interstate general special shipments. Per cent.	Total for all interstate traffic, all classes. Per cent.
Adams .....	15.36	0.71	16.07
American .....	13.14	.74	13.88
Southern .....	17.50	.94	18.44
United States .....	14.14	.67	14.81
Wells Fargo .....	14.89	.47	15.36
Average for five companies.....	14.65	.68	15.33

The contentions of the respondents that the rates submitted by the commission are unduly low are based upon the theory that the business of October 23, 1912, was normal and fairly representative of the conditions governing traffic throughout the year. It has been assumed by them that the various classes of traffic move in the same ratio one to the other each day throughout the year, and that whatever reductions in revenue are indicated by the experimental application of the commission's rates to certain classes of this traffic for the selected day must be accepted as proving the results that would follow the application of such rates to the actual business of extended periods.

It is apparent that the test of October 23 has produced results which are not indicative of the results that would follow the adoption of these rates, for it is evident from the returns that the business of October 23 was abnormal.

The average daily revenue from express transportation of the five leading respondents for the year ended June 30, 1912, on the basis of 313 business days (the factor employed by the Great Northern Express Company) was therefore \$459,772.56. The revenue on October 23, 1912, as reported to the commission, was \$517,895.34, or 12.64 per cent. more than the average daily revenue for the preceding fiscal year. As the respondents have made their claims of reductions in revenue by an application of the claimed percentage of loss for the one day to the total revenue of the preceding fiscal year, the nature of the revenue of October 23 is of the greatest consequence.

A comparison of the weights and revenues on October 23, 1912, with the weights and revenues during three months of 1909 showed that although there was no appreciable increase in the average weight per package, the average revenue per package on October 23, 1912, had increased from 1 per cent. to 72.1 per cent. over the average revenue per package for the three months of 1909.

The scales of rates of these respondents were practically the same on October 23, 1912, as they were throughout the three months. The average weight of the packages was not increased on that day. The causes of the increased revenue must be found either in an increase of the average journey for that day, or in an increased proportion of merchandise shipments, or both.

So for this day in October (a month which produced over one-tenth of the amount of the gross revenue for the preceding fiscal year) the commission is presented a showing which indicates 12 per cent. more revenue than the daily average for that year, and from 6 to 10 per cent. greater returns from merchandise rates than upon normal days. It is also shown, as a basis for estimated reductions in revenue, average revenues per piece which exceed the average of the three months by from 1 per cent. to 72 per cent., and is asked to conclude therefrom that its proposed rates are too low.

The reductions caused by the commission's proposed rates fall most heavily upon the long-haul traffic. A preponderance of long-haul traffic in a given day's business would present the indication of a greater reduction than if the business of that day

were normal. Likewise, the proposed rates effect a greater percentage of reduction upon shipments carried under the merchandise rates than upon any other class of traffic. Whatever may have been the cause of the increase in the average return per package on October 23, the resulting statements of reductions in revenue, when used as averages for extended periods of normal traffic, are untrustworthy and misleading.

Together with their report of the actual revenues for October 23, 1912, these carriers also reported the revenue that would have accrued on each package had the commission's rates been applied instead of the present rates. The average revenue per package resulting from the proposed rates, as reported by these carriers to the commission for October 23, 1912, is either only slightly less or else greater than the actual average revenue per package reported by these same carriers for the three months.

It may be said that the business for October 23 was abnormal, and that is the conclusion forced by an analysis of the figures presented by the respondents. If this be the accepted conclusion, then the elaborate estimates of loss based upon those figures lose all persuasiveness. If this conclusion is not accepted, however, and the business of this day is regarded as normal, then it appears that the earnings per package at the proposed rates would not have been greatly below the actual average returns per package for the three months in any case, and that as to six of the nine respondents the returns per package for the day at the proposed rates would have been in excess of the actual average returns for the three months at the company's rates.

The respondents have attempted to show that the proposed rates will not provide a reasonable return to the railroads, the position taken being that even the existing rates do not give adequate return to the railroads in addition to the expenses of the express company and the expenses which the railroads have arbitrarily assigned for the purposes of this controversy to their express operations. This contention, however, is based upon theories and assumptions to which the record gives no support, such as the adoption of an arbitrary and theoretical basis for the apportionment of railroad expenses between passenger operations and freight operations, and the further adoption of a like basis for the allotment of passenger train expenses between passenger service, baggage service, express service, and mail service.

Respondents' showing of expenses of transportation is not persuasive. These expenses are claimed to be increasing faster than gross revenues. This claim is based upon a showing that includes payments to the railroads under the percentage contracts as such expenses, and which makes no satisfactory showing of the details of the division of the expenses of the express companies between their transportation and non-transportation activities.

The argument which has been made by the express companies is based upon the assumption that no greater number of packages will be carried in 1914 than were carried in 1912, even though their unjust practices be reformed and even though the present unjust and unintelligible mass of rates be succeeded by a just and intelligible system. The showing has been considered without rejection of the assumption and without consideration of the increase in business that may be expected to result from fair dealing.

Also no account has been taken of the large amount of business carried by the respondents without charge. While it may be that the franks issued by them are within the law, nevertheless the expense of this portion of the express business is not legitimately to be charged to the paying patrons. It must be treated as a gift from the stockholders of the respondents to the favored holders of the franks. The amount of this business was not fully reported for October 23. What was reported, however, when computed on the basis of the average charge that accrued on the revenue packages, indicates the possibility of a substantial addition to the yearly revenues without injustice to anyone.

The losses in revenue from this free service, calculated according to the methods used by the respondents in estimating the reductions of revenues under the commission's rates, are thus shown to be \$2,058,028, if account be taken of only the incomplete showing of free service made in the returns for October 23.

A considerable portion of respondents' argument is to the effect that the loss of business to the parcel post will so far reduce their earnings as to render all previous investigations valueless. This is equivalent to saying that inasmuch as shippers have been given the convenience and economy of the parcel post the express carriers must, on that account, be allowed to charge rates higher than would otherwise be reasonable. That is to say, the commission is called upon to take from shippers of the country all the benefit that they receive from the parcel post and give it to the respondents in the form of higher rates upon the remaining express business.

With regard to the small-package business of the parcel post it should be noted, however, that it will still be carried upon the railroads of the country. So far as the rail carriers are concerned, it is of no consequence to them whether they furnish rail transportation for the express respondents herein or for the Post Office department. The express companies, moreover, will not experience a gross loss of their earnings upon these small parcels, but only of the net difference between their earnings heretofore and the cost to them of furnishing terminal service upon these parcels. The commission's conclusion is that the establishment of the parcel post is not a justification for any higher scale of rates than the one here shown to be reasonable.

The commission's order is for two years only. That period will give abundant opportunity for a test of these rates under varying conditions amounting to a normal average. In no other way can the absolutely proper rate basis for the respondents be finally determined. Respondents are also at liberty at any time to bring forward new facts as a basis for a petition for modification of this or any other order.

The rates prescribed in the order are those shown in the report of June 8, 1912, and those prepared subsequent to that date and submitted under the orders to show cause hereinbefore recited. Some typographical errors have been corrected and a few relatively unimportant rates between points in geographical proximity, but connected by circuitous rail routes, have been increased to allow for existing transportation difficulties.

The commission decided that the rates prescribed in the order are just, reasonable, and non-discriminatory, and they ordered that on and after October 15, 1913, the respondents shall cease charging for the transportation of express matter, between the points named, any rate in excess of the rates therein prescribed.

The Long Island Railroad Company, during the pendency of these proceedings, carried on its own express traffic, and was not a party. No order, therefore, is made as to rates to or from points on the lines of that railroad. The consideration of these rates is left for subsequent proceedings unless its successor shall voluntarily concur in rates conforming to those named in the present order.

**SIGNALING IN INDIA.**—During the calendar year 1912 101 stations were fitted with apparatus for interlocking switches and signals, but 291 stations with instruments for block signaling.

**RAILWAY SCHOOLS IN INDIA.**—The use of railway schools in India continued to be appreciated during 1912, and at the close of the year there were 9,682 children and 9,591 apprentices and workmen attending these schools.

**RAILWAY EMPLOYEES IN INDIA.**—The total number of employees in India at the close of 1912 was 589,422, of which number 7,850 were Europeans, 10,066 Anglo-Indians and 571,506 Indians.

**ACCIDENTS IN INDIA.**—During the calendar year 1912 the number of passengers killed on Indian railways from causes beyond their own control was 0.02 per million of passengers traveling, which gives an average of 1 in 2,188 millions of miles traveled.

# ELECTRIC TRUCKS IN FREIGHT HOUSE SERVICE.

Instances of the Use of These Trucks in Railway and Steamship Service Resulting in Greatly Increased Efficiency.

While electric storage battery trucks have not been used in as many instances or for as long a period for handling freight in storehouses and on piers as have similar trucks in the handling of baggage and mail, a number of railways and steamship companies have adopted such trucks in the former service with resulting economy. The Automatic Transportation Company, Buffalo, N. Y., has electric freight trucks in use by the Erie at Jersey City, N. J., Marion, Ohio, and Salamanca, N. Y.; by the Rock Island at Sylvis, Ill.; by the Louisville & Nashville at Pensacola, Fla.; by the New York Central & Hudson River at Utica, N. Y.; by the Baltimore & Ohio at Chicago; by the Hoboken Shore Road at Hoboken, N. J.; by the Panama Railroad at Colon, Canal

labor. The first large installation of trucks handling railroad freight was made by the Erie at its Jersey City terminal, where 24 trucks were installed on its transfer pier No. 6. This station consolidates and transfers about 600 tons of freight daily. The L. C. L. freight received at the various New York stations is brought here at the close of each day in cars and barges, checked out and distributed, some to fast freight trains leaving on schedule time and some to way freights. The following detailed comparison of the cost of handling freight for one year after the installation of electric trucks, with the operation with hand trucks for the year before, shows the relative economy in favor of the electric trucks:



Trucks Used by the Rock Island at Sylvis, Ill.

Tonnage handled .....	Electric trucks 170,170 tons			Hand trucks 183,371 tons		
	No. men	Amount paid	Cost per ton	No. men	Amount paid	Cost per ton
Fixed charges—Foremen, clerks, cooper and sealer...	9	\$6,425.38	\$0.038	9	\$6,392.01	\$0.035
Checking—Checkers and callers	13	8,715.13	.051	17	10,830.23	.059
Labor—Loaders, stevedores, truckers .....	57	31,455.33	.185	103	54,119.00	.295
Total operating cost.....	79	\$46,595.84	\$0.274	129	\$71,341.24	\$0.389
Decrease with electric trucks.....				50	\$24,745.40	\$0.115

In addition to the labor cost for handling the freight the operation of the trucks required a day and night electrician and a helper, the yearly wages of the three men being \$2,031.69. The electric current consumed cost \$962.22; the trucks averaging a fraction over 7 k. w. per day each. The trucks are charged from a power line supplied by the generating station which furnishes light and power for the Jersey City terminal at night. The ability to charge the trucks during the day when the normal load on this station is very low, greatly reduces the cost of power for charging. The supplies and repair material used on these trucks for one year cost \$617.79, including oil, paint, acid, distilled water and small repair parts. A large part of this amount was used in replacing the lead cells which had been broken by careless handling. The batteries were renewed for the second year at a cost of \$1,700, the normal life of a lead battery being one year's service. The Erie has charged these trucks with five per cent. per year depreciation as well as five per cent. interest on the investment.

The Erie lately placed five trucks at each of its transfer sta-

Zone; by the Merchants & Miners Transportation Company at Savannah, Ga., Norfolk, Va., and Jacksonville, Fla.; by the Old Dominion Steamship Company at New York and Norfolk, Va.; by the Boston Terminal Company, Boston; by the Baltimore Steam Packet Company, Norfolk, Va., and by the Detroit & Cleveland Navigation Company, Detroit, Mich. Other companies manufacturing electric trucks have also made installations in freight houses and piers.

In general, the economy of the storage battery electric freight house or warehouse truck depends on the loads it carries, the distance it carries them and the rates that are paid locally for



Electric Trucks Used in Loading Cars on Merchants' & Miners' Transportation Pier at Savannah, Ga.

tions at Salamanca and Marion and arrangements are being made to increase this number to 10 at Salamanca and 15 at Marion. The payroll saving in the cost of handling freight at these two points due to the installation of the trucks was \$0.15 and \$0.13 per ton, respectively. Both these points are local L. C. L. freight transfer stations, about 450 tons per day being handled at Salamanca and about 600 tons per day at Marion. One platform, at Marion, is particularly narrow, being only 8 ft. wide and a truck which is designed to work in congested districts is used there.

The New York Central freight house at Utica, N. Y., has been equipped with six electric trucks handling both inbound and outbound freight, as well as transfer. Two of these trucks were first installed and the following check was made of their operations: An operator and one laborer were assigned to each truck to pick up freight requiring the longer hauls to transport and stow it. The labor cost for each truck was \$0.18 per hour. The two trucks did the following work in one week:

Hours worked	Tons handled	Packages handled	No. of loads	Distance traveled
115	350	11,111	388	309,600 ft.

The average performance of each truck would be as follows: 1,818 lbs. per load consisting of 28.6 packages of 63 lbs. each

time of one hour and five minutes. Under ordinary conditions the work would have been done by a hand truck gang, consisting of two loaders, two stevedores, eight hand-truckers and two helpers on the grade. This gang would require about one hour and fifteen minutes to unload a car.

The electric truck has been used at various points for handling steamship freight with very large resulting economies. Where freight is trucked in and out of the hold through the portholes, as is the case with a good many coastwise vessels, the trucks can run directly in and out of the hold. Where freight is handled in and out of the vessel in sling loads by means of hoisting machinery, as is customary with the larger vessels, the trucks can deliver to or take from the slings a complete load. These loads can be made up on the truck when loading and be carried away at a single trip when unloading.

On the first day that eight of these trucks were installed on the Cunard Line piers in New York, they worked from 1 p. m. to 6 p. m. and from 7 p. m. to 11 p. m., or nine hours. They took all of the freight coming from four slings, operating three hatches. The freight consisted of miscellaneous boxes, most of which contained macaroni and lemons, and had to be trucked from 150 to 200 ft. from the ship's side and stowed on the pier. The eight trucks with eight operators replaced a force of 32



Truck Carrying Pipes on Pier of the Merchants' & Miners' Transportation Company, Savannah, Ga.

hauled an average distance of 798 ft. The average number of loads per truck per hour was 3.4, or 18 min. per load. In a ten-hour day the two trucks handled 61 tons. With a regular organization this performance can, of course, be much improved. To have loaded, hand trucked and stowed the 61 tons of freight in ten hours, covering the same distance as in the case of the two electric trucks, would have taken a force of ten loaders, hand-truckers and stevedores.

In one instance the handling of fruit, consisting of oranges and canteloupes, from refrigerator cars on a car float to the pier and bulkhead, including the stowing away, cost \$0.125 with the use of electric trucks. This cost includes the loaders, truck operators and stowers. This figure seems more unusual when it is considered that the platforms on car floats are narrow, that the doors of refrigerator cars are narrow and that the incline from the float to the pier was steep—under some conditions being equivalent to a grade of 25 per cent. To each of these refrigerator cars there were assigned two electric trucks with two motormen, three loaders and three stevedores. The loads were carried an average distance of 300 ft. and the cars, with an average tonnage of 13.1 tons, were unloaded in an average

hand-truckers. The laborers received \$0.33 an hour, \$0.50 an hour after 6 p. m. and \$0.60 an hour on Sundays. The labor saving occasioned by the use of the eight trucks for this first day's work of nine hours was therefore \$87.60, or \$1.22 per truck per hour. The saving can, of course, be increased with longer haul as shown by the fact that when these trucks carried freight to the bulkhead of the pier, a distance of 600 to 700 ft., each truck did the work of eight men with a resulting labor saving of \$2.64 per truck per hour.

At another steamship pier these trucks are in use in unloading cargoes of wine, the vessels usually bringing 6,000 to 8,000 50-gal. barrels. Each sling hoists three barrels, which, under the old method were dropped on the pier and rolled several hundred feet to the bulkhead by laborers stationed a short distance apart. With the electric trucks the barrels are dropped on a small portable platform from which six barrels are tipped onto each of the trucks and carried away to the stowing place. The seven trucks handled an average of 547 barrels per hour, each barrel weighing about 500 lbs., at a saving for labor of \$8 per hour.

At another pier coastwise steamers were discharged by the use of these trucks at an average saving in the cost of handling

barrels, boxes and case goods of \$0.10 per ton. In this case, freight was trucked from the hold through the portholes and stowed on the pier. At another point where the operation was similar to the last case mentioned, but where the labor rates are very low, the average saving compared with hand trucking made by each truck in the first six months' service was \$600, or \$100 per month per truck.

These trucks are also in service at a large number of industrial plants for handling raw materials, products in the course of manufacture and finished products being loaded out. They are particularly valuable for use in machine shops, foundries, car shops, warehouses, etc. One typical installation of trucks in this service showed the following record: One truck in one day carried 2,004 packages weighing 72.25 tons, making 71 loads, the working time being 8 hours and 36 minutes, and the distance under load 140,800 ft., or 26.7 miles. The average load was 28 packages of about 70 lbs. each, or one ton. The average distance was 1,983 ft., which was made in the round trip time of 7.25 minutes. A number of special types of trucks have been designed to meet the widely varying conditions encountered in such industrial plants.

These trucks are made in a number of types, all of which have the same operating mechanism. The frame consists of two steel channel sections extending the entire length of the platform which are supported on four spiral springs encased in malleable iron boxes which transfer the weight on the platform directly to the axles. The loading space on the largest truck made for freight house service is 6 ft. 9½ in. by 41 in., the over-all length of all of the trucks being 9 ft. 3 in. The batteries are carried in a box above the platform at the front end of the truck and the rear platform is closed by an end gate which is arranged to be lowered to a horizontal position to increase the length of the loading platform for handling long pieces. When this end gate is lowered the length of loading space can be increased to 9 ft. 9½ in.

The power from the batteries is taken through a maximum capacity fuse, the line being equipped with a circuit breaker and drum type controller. A set of resistances operated by a lever moving in a vertical plane, gives five speeds forward and five reverse, varying between one and ten miles per hour. A foot pedal is provided which must be pushed down by the operator before power can be sent into the controller. The releasing of this foot pedal sets the band brake on the jack shaft and closes the circuit breaker. From the controller the power is sent directly through the 2 h. p. motor, which is mounted between the frame members just behind the leading axle. The pinion of the motor is connected by a Morse silent chain to a sprocket wheel on the axle about four times the diameter of the pinion, a substantial and compact differential being provided on the axle. The gear ratio with the driving wheel is 12 to 1.

The axles are rigid under the frame and are set in annular roller bearings which are mounted in solid ribbed cast wheel centers provided with solid rubber or fabric tires, making a wheel with a total diameter of 16 in. The steering is done by means of a lever moving in a vertical plane, the wheels being moved independently for steering as is the case in all standard automobiles. The trucks vary in weight from 2,125 to 2,220 lbs. and have a load capacity of 2,000 lbs. The motor has a capacity sufficient to handle a loaded truck up a 15 to 25 per cent. grade.

**ZULULAND RAILWAY EXTENSION.**—The inclusion in the present railway extension proposals of a short standard-gage line from the present main line to Eshowe, the old capital of Zululand, has been received with much satisfaction. The line will traverse the Ginginhlovu battlefield, which still bears indications of the severe struggle with Cetewayo's hordes, and it will be the means of tapping a rapidly developing sugar area of great potentiality. Eshowe is at present served by a motor service.

## A NEW PUBLIC SERVICE LAW IN PENNSYLVANIA.

The legislature of Pennsylvania has abolished the state railroad commission, a body of six years' standing, and has established in its stead a "public service commission" of seven members; and has adopted an entirely new law. The new commission is already in office.

The new law clothes the commission with much more extensive powers than the railroad commission possessed. The latter could recommend only, while the new commission has powers like those existing in New York, Massachusetts and other states to compel compliance with its orders. The law gives the commission authority over 25 lines of industry in public service, including railroad, electric railroad, gas, electric light, stage line, express, pipe line, baggage transfer, ferry, turnpike, bridge, wharf, telegraph, telephone, heat, water, refrigerator, sewage and municipal corporations. The law contains most of the far-reaching and drastic features of the public utilities laws of other states, recently adopted, including provisions regulating the issue of stocks and bonds by public service companies. The commission has exclusive jurisdiction over the construction, relocation and abolition of grade crossings, the expenses to be borne by the public service companies, the municipalities benefited and the state, in proportions the commission deems equitable.

The act does not apply to the generation, transmission or distribution of electricity, gas, water or steam for use by the producer or his tenants.

Every public service company must furnish and maintain service in all respects "just, reasonable, adequate and practically sufficient for the accommodation and safety of its patrons, its employees and the public, and in conformity with such reasonable regulations or orders as may be made by the commission."

Changes in tariffs can be made only after 30 days' notice to the commission and the public. The commission is empowered to determine whether the contemplated changes are reasonable and may allow or deny the company the right to make them. Every public utility is entitled to the full enjoyment and exercise of all its rights, powers and privileges lawfully possessed when the act was signed. A corporation, except it be a street railway, may extend its service through a municipality without the consent of the municipality to reach some more distant point, but the commission has the power to order connections one with another.

The signing and attestation of unauthorized stocks and bonds by the officers of a public service company, or the assenting to such issue by the directors, is punishable by fine and imprisonment.

The commissioners will serve for ten years each. Each commissioner will receive \$10,000 a year, except the chairman, whose salary is \$10,500. Four members of the commission will be a quorum, and hearings may be held by any of the commissioners. The Dauphin County Court (Harrisburg) has appellate jurisdiction in certain cases and in all injunction and mandamus proceedings.

The secretary will receive \$5,000 a year; chief counsel, \$7,500; assistant counsel and investigator of accidents, \$5,000 each, and marshal, \$2,000. Attorney-General Bell becomes general counsel of the commission by virtue of his office, and the act empowers him to name the counsel and assistant counsel.

The governor named the commissioners last week, and he included the three members of the old railroad commission. The full list is as follows:

Nathaniel Ewing, chairman (was head of the State Railroad Commission); ten-year term.

S. Larue Tone, hitherto general manager and chief engineer of the Pittsburgh Railways Company; nine-year term.

Samuel W. Pennypacker, ex-governor and member of the old railroad commission; eight-year term.

Emory R. Johnson, Philadelphia, professor of transportation and commerce, University of Pennsylvania; seven-year term.

Milton J. Brecht, member of the old railroad commission, six-year term.

Charles F. Wright, ex-state treasurer, five-year term.

Frank M. Wallace, banker, four-year term.

Mr. Tone is a graduate of Rensselaer Polytechnic Institute, and has served 20 years with the Pittsburgh Railways Company, in charge of engineering, power and operating departments. Mr. Wright is vice-president of the First National Bank of Susquehanna, and is interested in manufacturing and water power enterprises. He has been a member of Congress and state treasurer. Mr. Wallace is president of the Second National Bank of Erie, and treasurer of the Pittsburgh Coal Company.

The name of Dr. Emory R. Johnson is the most prominent one in this list; he has a national reputation as economist and writer. Professor Johnson was born at Waupun, Wis., March 22, 1864, and was graduated from the University of Wisconsin in 1888. He received the degree of Ph. D. from the University of Pennsylvania in 1893. After graduation he continued his studies in Germany; and then for three years, 1893-1896, he was instructor in economics at Haverford College. He has been professor of transportation and commerce at the University of Pennsylvania since 1896, and he has been a student of transportation for more than twenty years. In this field he stands in the first class. He is the author of the following books: "Inland Waterways: Their Relation to Transportation," 1893; "American Railway Transportation," 1903; "Ocean and Inland Water Transportation," 1906; "Elements of Transportation," 1909; and "Railroad Traffic and Rates," 1911, the last named jointly with Dr. G. G. Huebner. He is the editor of Appleton's "Railway Series," which includes a number of books by others than himself; and for many years he has been editor of the "Annals," of the American Academy of Political and Social Science. Dr. Johnson's books, however, represent but a fraction of his writings. He has done a large amount of work for the United States government, beginning more than fourteen years ago. In 1899, President McKinley appointed him a member of the Isthmian Canal Commission, which place he held for five years. He made a thorough report on the industrial and commercial value of an Isthmian Canal, and during the past two years he has made elaborate reports on the traffic and tolls of the Panama Canal, which were sent to Congress by President Taft, and were the basis of the president's recommendations concerning rates of toll and other matters. This last report embodied an exhaustive and comprehensive study from a traffic standpoint of all the great canals of the world. In 1904 Professor Johnson made a report on valuation of railroad property, for the Census Bureau, and in 1908 one on transportation by water, on the Atlantic and Gulf coasts. In 1909 he went to Europe with the National Waterways Commission. He is still engaged on important studies for the government in connection with the Panama Canal.

### RAILROAD SMOKE INSPECTORS' ASSOCIATION OF CHICAGO.

According to the United States Bureau of Mines, Chicago stands foremost in the matter of a scientific solution for the smoke problem of large cities. The Smoke Inspection Bureau of that city is composed of 25 inspectors whose chief duties are the inspection of the stationary plants. The locomotive smoke is inspected by men in the employ of the railroads entering Chicago who co-operate with the city inspector. Each year the city inspection bureau makes a series of observations extending over a period of about two months to determine the progress made by the railroads in the reduction of locomotive smoke. As a means of obtaining concerted action among the railroads in this matter, the General Managers' Association of Chicago appointed a committee, of which H. T. Bentley, principal assistant

superintendent of motive power and machinery, Chicago & North Western, is chairman, to investigate the locomotive smoke problem. This committee found that the inspectors in service on the various roads were not able to give the service desired, and in the latter part of 1912 it was decided to pool the services of these men so that wherever they might be it was their duty to inspect the smoke of any locomotive of any road, and make their reports to the local company's smoke inspector and to the General Managers' Association, so that immediate action could be taken. In this way the usefulness of the smoke inspectors was greatly increased. The chief smoke inspectors of each road meet every two weeks and go over the reports submitted during that time, discussing the ways and means of improving conditions and securing uniformity of action. If necessary, a number of inspectors are placed in a territory where the smoke is exceptionally bad to overcome the trouble.

As a means of determining the best possible way in which to reduce smoke from locomotives, the General Managers' Association made a series of tests on various smoke devices; these tests were conducted by the Pennsylvania Railroad on the testing plant at Altoona.\* As a result of these experiments it has been recommended to the General Managers' Association that all the locomotives entering Chicago be equipped with the device recommended in the report. From the meeting of the Railway Smoke Inspectors' Association of July 25, it was learned that most of the roads operating in Chicago have already equipped their locomotives with smoke consuming devices, such as steam jets, brick arches, etc.

The results obtained by this joint association are well illustrated by the annual report of the city smoke inspector of Chicago, which is given in the accompanying table. This inspection was made by six of the city's inspectors over a period of 48 days; there were 11,151 observations made during that time. The table clearly shows the way in which the different roads are endeavoring to reduce locomotive smoke. While the biggest improvement over last year was made by the Illinois Northern, which jumped from the twenty-third place last year to the second place this year, the Chicago & North Western deserves a great deal of credit in moving from sixteenth place to fourth place, as that road operates in Chicago very nearly twice as many locomotives as any other road. The value of such an association to Chicago is very great, and the work of the railroad inspectors is greatly appreciated by the City Inspection Bureau.

YEARLY REPORT OF THE CITY SMOKE INSPECTOR OF CHICAGO ON LOCOMOTIVE SMOKE DENSITY.

Railroad.	Summer 1913—		Summer 1912—	
	Per cent. Density.	Standing	Per cent. Density.	Per cent. Density.
1 A. T. & S. F. ....	4.73	2	4.75	
2 Illinois Northern .....	6.31	23	17.92	
3 Illinois Central .....	7.43	4	6.98	
4 C. & N. W. ....	7.65	16	12.94	
5 C. B. & Q. ....	7.74	1	3.51	
6 L. S. & M. S. ....	9.49	9	11.55	
7 Soo Line .....	10.86	24	19.18	
8 C. M. & St. P. ....	11.75	6	9.36	
9 N. Y. C. & St. L. ....	11.9	7	10.3	
10 B. & O. C. T. ....	12.14	8	10.53	
11 Michigan Central .....	12.23	5	8.98	
12 Chicago Great Western .....	13.37	3	5.6	
13 Baltimore & Ohio .....	13.4	25	20.92	
14 Wabash .....	14.12	20	14.89	
15 C. R. I. & P. ....	14.66	15	12.85	
16 C. & E. I. ....	14.73	14	12.47	
17 C. & O. ....	14.78	Not listed	.....	
18 C. R. & I. ....	14.94	21	15	
19 C. I. & S. ....	15.12	13	12.18	
20 C. I. & L. ....	15.63	11	12.15	
21 C. & A. ....	16.56	10	11.62	
22 Pennsylvania .....	16.58	19	14.4	
23 Grand Trunk .....	16.62	17	13.08	
24 Chicago Junction .....	17.01	28	24.84	
25 C. & W. I. ....	17.1	12	12.16	
26 Belt .....	18.06	22	16.87	
27 E. J. & E. ....	18.45	29	31	
28 Pere Marquette .....	18.8	18	13.18	
29 Erie .....	20.51	27	21.76	
30 J. H. B. ....	26.22	Not listed	.....	
31 South Eastern .....	28.23	Not listed	.....	
32 C. S. Line .....	29.23	31	40	

\*The results of these tests were presented in a paper before the American Railway Master Mechanics' Association at the recent convention at Atlantic City, and were published in the *Daily Railway Age Gazette* of June 14, on page 1377.



**RUMSEY MAIL CAR DOOR.**

The Rumsey Car Door & Equipment Company, Chicago, has recently developed a mail car door including the principles involved in its standard freight car door. The illustrations of the door sections show clearly how these features have been included in the new door. When closed, the door is forced to a positive bearing on all four sides by the door post sealing flanges, which not only make it watertight but keep the cold out in winter.

The chief point of interest in the Rumsey car doors is the

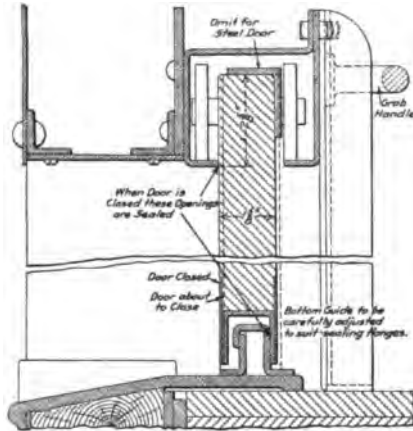

**Vertical Section Through Rumsey Door for Postal Cars.**

pressed steel, unitary post structure anchored at the top and bottom to the car sills and into which the door interlocks when closed, making it thereby an integral part of the superstructure. Any shock received by the door is transmitted through its interlocking feature to the posts, which by their anchorage transmit it to the superstructure. These pressed steel posts will stand a strain of 13,300 lbs. without the wood fillers and 15,000 lbs. with the fillers in place; to illustrate further, they take a stress equal to the resistance of a stick of oak 42¾ in. x 4¾ in. This represents the stress received at the center of the post, when No. 10 gage open hearth steel is used.

The combined steel and wood post is similar to what is known

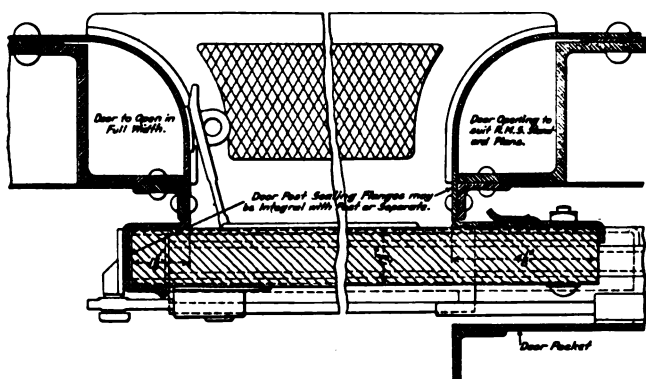

**Horizontal Section Through Rumsey Postal Car Door.**

as the Harriman standard. The steel member extends sufficiently beyond the face of the post to form interlocking sealing flanges whose functions are identical with those of the all-steel post, and this construction is recommended for rebuilt equipment and for stock cars, owing to its moderate cost.

This company has also designed a flush door which does not interfere with the strength of the car superstructure and is the type recommended for stock and refrigerator cars. This particular type of door is also applicable to box cars of all dimensions.

**General News.**

The roundhouse and shops of the Chesapeake & Ohio at Cane Fork, W. Va., were destroyed by fire on July 28; estimated loss \$50,000.

The South Dakota state tax commission has announced the assessment values of railway property in the state for the year, which have been increased from \$32,001,000 in 1912 to \$124,231,861 in 1913. This is an average of \$29,529 per mile.

A Rock Island train was delayed for 40 minutes on July 30, near Ford, Kan., by a large number of grasshoppers that had blown on to the tracks at a deep cut. The trainmen were obliged to scoop them off the tracks with shovels and to sand the rails before the train could proceed.

Birmingham, Ala., reports a new kind of train robbery. The registered mail in the mail car of northbound train No. 4, of the Louisville & Nashville, was carried off, on the evening of August 5, by two robbers who got into the car at Calera, and handcuffed and bound the mail clerks, taking their time to do the job between Calera and Birmingham, 33 miles.

Charles J. Doherty, the engineman who figured in the rear collision of passenger trains on the New York, New Haven & Hartford at Stamford, Conn., June 12, was released by the City Court at Stamford August 1, the prosecuting attorney having asked for the dismissal of the charge of manslaughter in view of the action of the coroner, exonerating the engineman from criminal liability.

The Wells-Fargo Express announces that if it has to submit to the drastic reduction in rates which has been ordered by the Railroad Commission of California, it will withdraw from that State. Application will be made at once for a writ of review, and the contest will be taken to the highest court if necessary. For Wells-Fargo to withdraw from California would seem something like the Erie canal withdrawing from New York.

President Schaff of the Missouri, Kansas & Texas has announced that on account of the recent action of the attorney-general of Texas in instituting suit against the company and various subsidiaries for alleged violation of the anti-trust law, all work of improvement and extension on the system would necessarily have to be suspended, as the companies could not afford to take the responsibility for expending large sums in the face of the hostile attitude of the state administration, as manifested by this litigation.

Eugene Gilbert, a French aviator, on Sunday last flew from Paris to the town of Pejabo, on the Portuguese frontier, a distance of 1,030 miles, in an effort to win the Pommery Cup which is given for the longest flight in a single day. Gilbert beat the record of 875 miles made on June 11 last by des Moulinais, flying from Paris to Warsaw. Gilbert left Paris at 4:45 a. m., and flew for 7 hours without a stop to Victoria, in Spain, where he landed. Ascending again at 1 p. m., he headed for Portugal, and at 8 p. m. descended at Pejabo.

The conductors and brakemen of the Bangor & Aroostook have signed an agreement with the officers of the road to continue at work for another year at the present rates of pay. This road is not a party to the agreement for arbitration at New York City. The agreement under which these men have been working on the Bangor & Aroostook expired last February, about the time when the enginemen and firemen struck. Officers of the road say that henceforth contracts with employees will be made for terms which expire in the summer months, when traffic is light.

Representative Cullop of Indiana, has introduced in Congress a bill to give the Interstate Commerce Commission jurisdiction over all future consolidations of railroads and over the issue of stocks and bonds and the use of moneys realized from the sale of securities. The bill declares illegal the acquisition of property by a railroad not needed in its construction, equipment, maintenance or operation, or not needed for legitimate improvements. Notes for periods of less than one year may be issued to an amount equal to three per cent. of the company's assets without supervision by the commission.

Senator Bryan in a speech in Congress last Saturday, opposing Postmaster General Burleson's orders reducing parcel post rates on August 15, advocated one cent postage for letters. "If we lose more than seven cents a pound in the transportation of newspapers and magazines, how can we expect to make a profit in the transportation of merchandise?" he asked. ". . . A former Postmaster General has transported second class mail matter by freight. With much further extension the present Postmaster General will be transporting freight by mail. Unless we stop until we have more information, pretty soon the people will go to the freight offices to get their mail and to the postoffice to get their freight."

The Chicago & Western Indiana and the Belt Railway of Chicago last week appealed to the United States board of mediation and conciliation for assistance in settling the wage controversy with the roads' engineers, switchmen and yardmen who had taken a strike vote. The labor organizations accepted the offer of mediation, and Messrs. Chambers and Hangar arrived in Chicago on Monday. They immediately went into conference with the officers of the roads and representatives of the employees. The controversy concerns a demand for an increase in wages and an objection by the men to a new rule adopted by the companies limiting seniority rights to each road, as the two roads are now under separate ownership.

The New York, New Haven & Hartford is abolishing 16 highway crossings and one railroad crossing at a cost of \$2,300,000. Plans are being prepared for the abolition of all grade crossings between Boston and Providence, 40 miles, and for eliminating crossings at Braintree, Quincy and Taunton, Massachusetts. Four of the crossings on which work is now in progress are in Massachusetts, and five in Rhode Island, at Pawtucket and Central Falls. This work includes the reconstruction of a section of the railroad about 1½ miles in length, and also the construction of a new joint overhead station. Two crossings are being abolished at Rumford, R. I., and two at Olneyville will soon be changed. Work is going on in Connecticut at Ansonia, Brookfield and Still River. The company has also authorized the elimination of crossings at Mill Plain and Winsted.

The arbitrators who have been chosen to consider the demands of the conductors and brakemen of the Eastern railroads—W. W. Atterbury, A. H. Smith, L. E. Sheppard and Daniel L. Cease—met in New York City this week in an attempt to agree upon the two additional arbitrators who will be required to complete the board, in accordance with the provisions of the law. President Wilson has designated Professor Royal Meeker, who has been nominated for the position of Commissioner of Labor Statistics, as the third member of the Federal Board of Mediation and Conciliation. This board has already been called upon to consider a number of railroad controversies. Commissioner William L. Chambers has gone to Chicago and to St. Louis to consider controversies on the Chicago Belt Railway, the Chicago & Western Indiana and the St. Louis Southwestern. Mr. Chambers or Mr. Hangar, or both, will go to San Francisco, at the request of the Southern Pacific, which is threatened with a strike of passenger train men.

#### An Unprofitable Mail Contract.

The Toledo, St. Louis & Western has given the postmaster general sixty days' notice that it will refuse to transport the mails after October 1. In view of the prospective increase in the parcel post business, the restrictive regulations imposed by the government and the inadequate pay, the road considers it to the best advantage to forego the postal business.

It is said that this is the first time that a railroad has ever flatly refused to carry out a mail contract with the government. The contract with the "Clover Leaf" has two years to run and the department will probably refuse to permit the road to cancel its contract.

Whether the Toledo, St. Louis & Western (Clover Leaf) will continue to carry Uncle Sam's mail on its passenger trains between Toledo and St. Louis after September 1 appears to hinge on the outcome of conferences to be held between officers of the company and the postmaster general within the next ten days.

The road receives \$62,000 a year for the mail service on its entire system. This has been the fixed remuneration for a number of years, and officers of the road declare that under new conditions it is required to do double its former service. All

stations and postoffices on the line can be reached by other steam and interurban roads. Recently the postoffice department notified the road that it must place a man each on duty at Forest and Michigantown, two small stations, in order to take care of mail from the night trains, patrons of both postoffices having complained of poor service. Apparently this is the straw that broke the camel's back. There are about 27 cities, towns and villages on the Clover Leaf route that can be reached by other steam railroads. Others can be served by traction lines, and still others must be reached by rural routes.

#### Railway Mail Pay.

Ralph Peters, chairman of the Railway Mail Pay Committee, says that the railways of the country, instead of being overpaid by \$9,000,000, as was claimed by former Postmaster General Hitchcock, are in fact underpaid by \$15,000,000. The postmaster general, in November, 1909, reporting on the exhaustive data furnished at that time by the railroads, said (House Document No. 105) that the committee of the department which had compiled the data "estimated that through a readjustment of railway mail pay on the basis of cost with 6 per cent. profit, a saving to the government could be made of about \$9,000,000." But this estimate of the costs to the railways of carrying the mails has since been abandoned by the post office department, primarily because the department did not in its first estimates make allowance for any return on that part of the railway plant used in the service. If to the post office department's own figures there is added proper interest on the investment and due adjustment is made as to the percentage of the railway plant used in the postal service, the following revised result is obtained as to the *minimum* cost:

1. Interest at 6 per cent on 1.95 per cent. (the share of the railway plant used for postal service) of the net capital investment of all the railways in the United States is \$16,380,000.
2. The space actually used for mail and incidental thereto, but eliminated from the department's calculations, \$9,600,000.
3. Difference between approved methods and the department's methods of separating freight and passenger expenses, \$5,000,000. Total, \$30,980,000.

If this sum is added to the net amount estimated in document 105 as the cost of carrying the mails, it will yield about \$15,000,000 more than the sum now paid for railway mail service.

The railroads maintain, therefore, that the most exhaustive inquiry ever made of this subject shows that a fair payment for the actual cost of the service would result in the companies receiving at least \$15,000,000 more than they are now paid.

#### Opening of Centre Street Subway, New York City.

The subway, built by the city of New York and finished some months ago, between the Williamsburgh bridge, in Manhattan, and the City Hall station, about one and one-half miles long, was opened for partial use on Monday last. This is a four-track line, designed to connect the Manhattan terminals of the Williamsburgh and the Brooklyn bridges, but only two of the tracks are at present in operation, and the connection, at the southern end, with the Brooklyn bridge, has not yet been completed. When all arrangements have been made this line will connect not only with the two bridges named, but also with the Manhattan bridge, which is midway between these two. Trains of the elevated lines in Brooklyn, coming over the Williamsburgh bridge to Manhattan, now use the new tracks and deliver passengers as far south as Chambers street station, which is under the new Municipal building.

#### Norfolk & Western Electrification.

The plans for the electrification of the Elkhorn-Bluefield section of the Norfolk & Western main line—about 30 miles—were noticed in the *Railway Age Gazette*, June 13, page 1319. Gibbs & Hill, consulting engineers, have recommended the adoption of this installation of the single phase system. They have made an exhaustive analysis of systems now in use in this country and abroad, and a careful study of local conditions; also comparisons of the capital and operating costs, based on operating data and manufacturers' bids for equipment. The intention is to use 25 cycle, single phase current at a potential of 11,000 volts at the trolley. Power will be supplied from a power house to be erected

at Bluestone, W. Va., with an installed capacity of 27,000 kw. For transmission purposes the potential will be raised to 33,000 volts, and the transmission line will be carried mainly on the catenary bridges. Feeding points will be established at suitable locations along the line sufficiently close to minimize voltage drop and inductive disturbances. In view of the fact that freight trains only are to be handled, the locomotives, of which there will be 24, are to have motors of the induction type, and the control and connections are to be arranged to give three running speeds of approximately 7, 14 and 28 miles an hour. Special attention is being given to the question of regeneration and electric braking on grades, which would decrease the wear and tear on train equipment, and also under favorable conditions tend to reduce the demand on the power house.

#### Des Moulinais.

Bleriot, Bellenger, Paulhan, Vedrines, Legagneux and Garros are some of the immortals who have upheld the prestige of France, but a greater has come upon the scene in the person of the pilot with the streaming name, Marcel Brindejonc des Moulinais, who has flamed in the sky of 1913 by flying 3,000 miles, from Paris to St. Petersburg and back to Paris, with the assurance and nonchalance of youth. Des Moulinais is not of age yet; a beardless boy. He drives an 80 h. p. monoplane through the uncharted air with as much coolness and precision as Burman or De Palma steers a bounding automobile in a road race. At 17 he mastered the Demoiselle, the butterfly of aeroplanes, which looked no safer than a scallop shell in the surges of the Atlantic. The boy was next heard of on the circuit in France, using his monoplane as if it were a perfected vehicle. When 1913 opened, being then 19, he was primed for great deeds. In three hours, five minutes he flew from Paris to London (287 miles) and then back to Paris by way of Brussels. Then came the red letter achievement of 1913, his long aerial voyage by way of Paris, Warsaw, St. Petersburg, Stockholm, Copenhagen, The Hague and Paris again, in fair weather and foul. He has flown at the rate of 140 miles an hour and he has the endurance of a roan horse.—*New York Sun*.

#### Cost of Valuation Work.

The Interstate Commerce Commission now estimates that it will take from five to seven years to value the property of the railways and that the work will cost the government from \$10,000,000 to \$15,000,000. The commission has asked for an immediate appropriation of \$1,500,000 for the organization of the corps of engineers necessary to undertake the work. Commissioners Clements and Prouty and Secretary McGinty have told the House appropriations sub-committee that a carefully worked out estimate places the cost of the field work at \$1,921,500 a year throughout the period. The plan presented by Mr. McGinty contemplates the division of the country into five districts containing approximately 50,000 miles of railroad each. In addition to the engineering work it is estimated that the accounting feature of the work will cost about \$350,000 a year, and that the maintenance of a valuation office in Washington will cost probably \$150,000 a year. Mr. McGinty was confident that the commission would be able to get the field force organized, through the Civil Service Commission, by the first of next year.

Valuations of one or more railroads have been made in twenty states. In most of these there have been no extensive or thorough inventories or appraisals. Texas made a comprehensive valuation about twenty years ago; Michigan and New Jersey have made elaborate valuations within recent years solely for taxation purposes. New York has valued several individual properties for various purposes. Oregon has valued several roads, but not all.

It is reported that at least eight states are making or planning physical valuations to be used for rate making. These are California, Kansas, Minnesota, Nebraska, Oklahoma, South Dakota, Washington and Wisconsin. Ten states have in recent years made or are making elaborate valuations of all the railroads within their borders. These are California, Kansas, Michigan, Minnesota, Nebraska, New Jersey, Oklahoma, South Dakota, Washington and Wisconsin. It is presumed that the Interstate Commerce Commission will begin its valuation of the railroads in those sections of the country where the states have made no start. Some states have already petitioned the Commission for permission to take advantage of the federal valuation so as to save them the cost of an independent valuation.

#### Railway Signal Association.

Secretary C. C. Rosenberg announces that the headquarters for the annual convention of this association, to be held in Nashville, Tenn., October 14, 15 and 16, will be at Hotel Hermitage, and members are requested to reserve rooms at the hotel at once so as to make sure that enough space will be set aside for those who are to attend the convention. Plans are being made for special trains from Chicago over the Chicago & Eastern Illinois and from New York over the Pennsylvania. On the 17th, after the close of the convention, there will be an excursion to Chattanooga; and if a sufficient number of members desire to make a daylight trip over the Cincinnati, New Orleans & Texas Pacific, General Manager Baker of that road will run a special train, with an observation car. Further particulars will be given in the official program for the convention which is to be distributed to members about September 16.

#### American Association of Railroad Superintendents.

The twenty-second annual convention will be held at the Hotel Sherman, Chicago, on August 21 and 22. The morning session on August 21 will be devoted to a business meeting, which will be followed in the afternoon by an address on the handling of explosives, inflammables and other dangerous articles, by Col. B. W. Dunn, and the report of the committee on Interchange Car Inspection, M. Marea, chairman, and the report of the committee on transportation, C. L. Gardner, chairman. The program for August 22 includes the report of the committee on Train Rules, B. F. Hoehn, chairman, an address on railway economics as they apply to the operating department, by W. W. Wheatley of New York, and an address on immigration in its relation to the operating department, by C. D. Schmidt, commissioner of immigration, Rock Island Lines.

#### International Railway Congress, 1915.

The permanent commission of the International Railway Congress Association, at its meeting in Brussels, last month, decided that the next session of the Congress should be held at Berlin, June 21 to July 3, 1915.

#### MEETINGS AND CONVENTIONS.

The following list gives names of secretaries, dates of next or regular meetings, and places of meeting.

- AIR BRAKE ASSOCIATION.—F. M. Nellis, 53 State St., Boston, Mass.
- AMERICAN ASSOCIATION OF DEMURRAGE OFFICERS.—A. G. Thomason, Boston, Mass. Convention, May 19, 1914, St. Louis.
- AMERICAN ASSOCIATION OF GENERAL PASSENGER AND TICKET AGENTS.—W. C. Hope, New York. Annual meeting, October 14-15, Philadelphia, Pa.
- AMERICAN ASSOCIATION OF FREIGHT AGENTS.—R. O. Wells, East St. Louis, Ill.
- AMERICAN ASSOCIATION OF RAILROAD SUPERINTENDENTS.—E. H. Harman, St. Louis, Mo.; 3d Friday of March and September.
- AMERICAN ELECTRIC RAILWAY ASSOCIATION.—H. C. Donecker, 29 W. 39th St., New York.
- AMERICAN ELECTRIC RAILWAY MANUFACTURERS' ASSOC.—H. G. McConnaughy, 165 Broadway, New York. Meetings with Am. Elec. Ry. Assoc.
- AMERICAN RAILWAY ASSOCIATION.—W. F. Allen, 75 Church St., New York. Next meeting, November 19, 1913, Chicago.
- AMERICAN RAILWAY BRIDGE AND BUILDING ASSOCIATION.—C. A. Lichty, C. & N. W., Chicago. Convention, October 21-24, 1913, Montreal.
- AMERICAN RAILWAY ENGINEERING ASSOCIATION.—E. H. Fritch, 900 S. Michigan Ave., Chicago.
- AMERICAN RAILWAY MASTER MECHANICS' ASSOCIATION.—J. W. Taylor, Old Colony building, Chicago.
- AMERICAN RAILWAY TOOL FOREMEN'S ASSOCIATION.—A. R. Davis, Central of Georgia, Macon, Ga.
- AMERICAN SOCIETY FOR TESTING MATERIALS.—Prof. E. Marburg, University of Pennsylvania, Philadelphia, Pa.
- AMERICAN SOCIETY OF CIVIL ENGINEERS.—C. W. Hunt, 220 W. 57th St., New York; 1st and 3d Wed., except June and August, New York.
- AMERICAN SOCIETY OF ENGINEERING CONTRACTORS.—J. R. Wenlinger, 11 Broadway, New York; 2d Tuesday of each month, New York.
- AMERICAN SOCIETY OF MECHANICAL ENGINEERS.—Calvin W. Rice, 29 W. 39th St., New York.
- AMERICAN WOOD PRESERVERS' ASSOCIATION.—F. J. Angier, B. & O., Baltimore, Md. Next convention, January 20-22, 1914, New Orleans, La.
- ASSOCIATION OF AMERICAN RAILWAY ACCOUNTING OFFICERS.—C. G. Phillips, 143 Dearborn St., Chicago. Annual meeting, May 28, Atlantic City, N. J.
- ASSOCIATION OF RAILWAY CLAIM AGENTS.—J. R. McSherry, C. & E. I., Chicago.
- ASSOCIATION OF RAILWAY ELECTRICAL ENGINEERS.—Jos. A. Andreuccetti, C. & N. W. Ry., Chicago. Annual convention, October 18-24, Chicago.
- ASSOCIATION OF RAILWAY TELEGRAPH SUPERINTENDENTS.—P. W. Drew, 112 West Adams St., Chicago.
- ASSOCIATION OF TRANSPORTATION AND CAR ACCOUNTING OFFICERS.—G. P. Conard, 75 Church St., New York.

## Traffic News.

As a means of relieving the industries of Cincinnati during the teamsters' strike in that city, the railways have petitioned the Interstate Commerce Commission for the privilege of canceling charges for storage as long as the teamsters' strike continues.

At the close of the convention of the American Association of General Passenger and Ticket Agents on September 9, at St. Paul, Minn., the agents will become the guests of the Northern Pacific for a tour of Yellowstone National Park, occupying eleven days.

Officers of the Ann Arbor have notified the Michigan Railroad Commission that the company proposes to contest the state two-cent fare law in the courts, claiming that the law is confiscatory. A suit of the Duluth, South Shore & Atlantic attacking the law is now pending before a master in chancery.

The attorney-general of Oklahoma is preparing suits against the principal railways of the state to collect refunds on passenger tickets sold within the state during the past three and one-half years, of the difference between the three cent fare which was collected, and the two cent rate which was finally sustained by the Supreme Court. The state corporation commission has estimated the total amount of the refunds due at over \$5,000,000.

During the month ending the 15th of July, 1,721 carloads of potatoes from the South passed through the Harlem River yard of the New York, New Haven & Hartford, destined for cities in New England, an average of 54 cars a day. In the same time there were sent through this yard 467 carloads of watermelons, 135 of cantaloupes, 112 of berries and 98 carloads of peaches. The movement of freight cars through this yard, eastbound and westbound, now amounts to about 5,000 a day.

The Circuit Court of Appeals of Kanawha county, W. Va., has appointed a commission to supervise the redemption of rebate coupons which have been issued by the Chesapeake & Ohio in connection with passenger tickets, during the past year or two, since the beginning of the litigation concerning the constitutionality of the two-cent fare law of West Virginia, which was finally decided against the road. The commission will redeem outstanding coupons, and will have a clerical force to be paid for by the railroad.

The Chicago Great Western has announced that it will within ten days put into effect the new two-cent passenger rates involved in the recent decision of the Supreme Court. The injunction which restrained seven railroads in Minnesota from applying the two-cent rates was not dismissed in the case of the Great Western, and the company had previously announced its intention of seeking to continue the three-cent rate. The attorney-general of Minnesota had expected to move for the vacation of the injunction on August 18.

Edward White, of Chicago, president and manager of the Chicago & New Orleans Transportation Company, has announced that a barge line will be put in service by this company on September 1, between Chicago and New Orleans. The plan of the company is to operate a fleet of 150-ton barges in the Illinois and Michigan canal from Chicago to La Salle, where the cargoes will be transferred to larger barges. Mr. White estimates that the trip can be made in a week, and with profit at freight rates approximately 75 per cent. of the current railroad rates; and he expects to carry 3,000,000 tons a year.

The St. Louis & San Francisco has announced a considerable reduction in passenger train service, to take effect August 10, by which eight trains will be discontinued, and the time of several others lengthened by additional stops to take care of the business formerly handled by the discontinued trains. A. Hilton, general passenger agent, has issued a circular announcing the changes, in which the retrenchment policy is explained as follows: "The necessity for the most rigid economy, in all directions, has resulted in making some reductions in the Frisco passenger train service. The following changes, which will take effect August 10, are the result of the most careful consideration—the purpose being to cause patrons the least possible inconvenience. The management earnestly urges a careful consideration and a fair trial of the new service."

ASSOCIATION OF WATER LINE ACCOUNTING OFFICERS.—W. R. Evans, Chamber of Commerce, Buffalo, N. Y. Annual meeting, October 8, Philadelphia, Pa.

BRIDGE AND BUILDING SUPPLY MEN'S ASSOCIATION.—H. A. Neally, Joseph Dixon Crucible Co., Jersey City, N. J. Meeting with American Railway Bridge and Building Association.

CANADIAN RAILWAY CLUB.—James Powell, Grand Trunk Ry., Montreal, Que.; 2d Tuesday in month, except June, July and Aug., Montreal.

CANADIAN SOCIETY OF CIVIL ENGINEERS.—Clement H. McLeod, 413 Dorchester St., Montreal, Que.; Thursday, Montreal.

CAR FOREMEN'S ASSOCIATION OF CHICAGO.—Aaron Kline, 841 North 50th Court, Chicago; 2d Monday in month, Chicago.

CENTRAL RAILWAY CLUB.—H. D. Vought, 95 Liberty St., New York; 2d Thurs. in Jan. and 2d Fri. in March, May, Sept., Nov., Buffalo, N. Y.

CIVIL ENGINEERS' SOCIETY OF ST. PAUL.—L. S. Pomeroy, Old State Capitol building, St. Paul, Minn.; 2d Monday, except June, July August and September, St. Paul.

ENGINEERS' SOCIETY OF PENNSYLVANIA.—E. R. Dasher, Box 704, Harrisburg, Pa.; 1st Monday after 2d Saturday, Harrisburg, Pa.

ENGINEERS' SOCIETY OF WESTERN PENNSYLVANIA.—E. K. Hiles, Oliver building, Pittsburgh; 1st and 3d Tuesday, Pittsburgh, Pa.

FREIGHT CLAIM ASSOCIATION.—Warren P. Taylor, Richmond, Va.

GENERAL SUPERINTENDENTS' ASSOCIATION OF CHICAGO.—E. S. Koller, 226 W. Adams St., Chicago; Wed. preceding 3d Thurs., Chicago.

INTERNATIONAL RAILWAY CONGRESS.—Executive Committee, 11, rue de Louvain, Brussels, Belgium. Convention, 1915, Berlin.

INTERNATIONAL RAILWAY FUEL ASSOCIATION.—C. G. Hall, 922 McCormick building, Chicago.

INTERNATIONAL RAILWAY GENERAL FOREMEN'S ASSOCIATION.—Wm. Hall, 829 West Broadway, Winona, Minn.

INTERNATIONAL RAILROAD MASTER BLACKSMITHS' ASSOCIATION.—A. L. Woodworth, Lima, Ohio. Annual meeting, August 18, Richmond, Va.

MAINTENANCE OF WAY & MASTER PAINTERS' ASSOCIATION OF THE UNITED STATES AND CANADA.—W. G. Wilson, Lehigh Valley, Easton, Pa.

MASTER BOILER MAKERS' ASSOCIATION.—Harry D. Vought, 95 Liberty St., New York.

MASTER CAR BUILDERS' ASSOCIATION.—J. W. Taylor, Old Colony building, Chicago.

MASTER CAR AND LOCOMOTIVE PAINTERS' ASSOC. OF U. S. AND CANADA.—A. P. Dane, B. & M., Reading, Mass. Annual meeting, September 9-12, Ottawa, Can.

NATIONAL RAILWAY APPLIANCE ASSOC.—Bruce V. Crandall, 537 So. Dearborn St., Chicago. Meetings with Am. Ry. Eng. Assoc.

NEW ENGLAND RAILROAD CLUB.—W. E. Cade, Jr., 683 Atlantic Ave., Boston, Mass.; 2d Tuesday in month, except June, July, Aug. and Sept., Boston.

NEW YORK RAILROAD CLUB.—H. D. Vought, 95 Liberty St., New York; 3d Friday in month, except June, July and August, New York.

NORTHERN RAILROAD CLUB.—C. L. Kennedy, C. M. & St. P., Duluth, Minn.; 4th Saturday, Duluth.

PEORIA ASSOCIATION OF RAILROAD OFFICERS.—M. W. Rotchford, Union Station, Peoria; 2d Thursday.

RAILROAD CLUB OF KANSAS CITY.—C. Manlove, 1008 Walnut St., Kansas City, Mo.; 3d Friday in month, Kansas City.

RAILWAY BUSINESS ASSOCIATION.—Frank W. Noxon, 2 Rector St., New York. Annual dinner, second week in December, 1913, New York.

RAILWAY CLUB OF PITTSBURGH.—J. B. Anderson, Penna. R. R., Pittsburgh, Pa.; 4th Friday in month, except June, July and August, Pittsburgh.

RAILWAY ELECTRICAL SUPPLY MANUFACTURERS' ASSOC.—J. Scribner, 1021 Monadnock Block, Chicago. Meetings with Assoc. Ry. Elec. Engrs.

RAILWAY FIRE PROTECTION ASSOCIATION.—C. B. Edwards, Mobile & Ohio, Mobile, Ala. Next meeting, October 7, Chicago.

RAILWAY GARDENING ASSOCIATION.—J. S. Butterfield, Lee's Summit, Mo. Next meeting, August 12-15, Nashville, Tenn.

RAILWAY DEVELOPMENT ASSOCIATION.—W. Nicholson, Kansas City Southern, Kansas City, Mo.

RAILWAY SIGNAL ASSOCIATION.—C. C. Rosenberg, Bethlehem, Pa. Convention, October 14, Nashville, Tenn.

RAILWAY STOREKEEPERS' ASSOCIATION.—J. P. Murphy, Box C, Collinwood, Ohio.

RAILWAY SUPPLY MANUFACTURERS' ASSOC.—J. D. Conway, 2135 Oliver bldg., Pittsburgh, Pa. Meetings with M. M. and M. C. B. Assocs.

RAILWAY TEL. AND TEL. APPLIANCE ASSOC.—W. E. Harkness, 284 Pearl St., New York. Meetings with Assoc. of Ry. Elec. Sups.

RICHMOND RAILROAD CLUB.—F. O. Robinson, Richmond, Va.; 2d Monday except June, July and August.

ROADMASTERS' AND MAINTENANCE OF WAY ASSOCIATION.—L. C. Ryan, C. & N. W., Sterling, Ill. Convention, September 8-12, 1913, Chicago.

ST. LOUIS RAILWAY CLUB.—B. W. Frauenthal, Union Station, St. Louis, Mo.; 2d Friday in month, except June, July and Aug., St. Louis.

SIGNAL APPLIANCE ASSOCIATION.—F. W. Edmonds, 3868 Park Ave., New York. Meeting with annual convention Railway Signal Association.

SOCIETY OF RAILWAY FINANCIAL OFFICERS.—C. Nyquist, La Salle St. Station, Chicago. Annual meeting, September 23-25, Chicago.

SOUTHERN ASSOCIATION OF CAR SERVICE OFFICERS.—E. W. Sandwich, A. & W. P. Ry., Montgomery, Ala.

SOUTHERN & SOUTHWESTERN RAILWAY CLUB.—A. J. Merrill, Grant bldg., Atlanta, Ga.; 3d Thurs., Jan., March, May, July, Sept., Nov., Atlanta.

TOLEDO TRANSPORTATION CLUB.—J. G. Macomber, Woolson Spice Co., Toledo, Ohio; 1st Saturday, Toledo.

TRACK SUPPLY ASSOCIATION.—W. C. Kidd, Ramapo Iron Works, Hillsburn, N. Y. Meeting with Roadmasters' and Maintenance of Way Association.

TRAFFIC CLUB OF CHICAGO.—W. H. Wharton, La Salle Hotel, Chicago.

TRAFFIC CLUB OF NEW YORK.—C. A. Swope, 290 Broadway, New York; last Tuesday in month, except June, July and August, New York.

TRAFFIC CLUB OF PITTSBURGH.—D. L. Wells, Erie, Pittsburgh, Pa.; meetings monthly, Pittsburgh.

TRAFFIC CLUB OF ST. LOUIS.—A. F. Versen, Mercantile Library building, St. Louis, Mo. Annual meeting in November. Noonday meetings October to May.

TRAIN DISPATCHERS' ASSOCIATION OF AMERICA.—J. F. Mackie, 7042 Stewart Ave., Chicago.

TRANSPORTATION CLUB OF BUFFALO.—J. M. Sells, Buffalo; first Saturday after first Wednesday.

TRANSPORTATION CLUB OF DETROIT.—W. R. Hurley, L. S. & M. S., Detroit, Mich.; meetings monthly.

TRAVELING ENGINEERS' ASSOCIATION.—W. O. Thompson, N. Y. C. & H. R., East Buffalo, N. Y.

UTAH SOCIETY OF ENGINEERS.—Fred D. Ulmer, Oregon Short Line, Salt Lake City, Utah; 3d Friday of each month, except July and August.

WESTERN CANADA RAILWAY CLUB.—W. H. Roseyear, P. O. Box 1707, Winnipeg, Man.; 2d Monday, except June, July and August, Winnipeg.

WESTERN RAILWAY CLUB.—J. W. Taylor, Old Colony building, Chicago; 3d Tuesday of each month, except June, July and August.

WESTERN SOCIETY OF ENGINEERS.—J. H. Warder, 1735 Monadnock Block, Chicago; 1st Monday in month, except July and August, Chicago.

#### Freight Claims Frauds Punished.

The United States District Attorney at New York City has secured a number of convictions in connection with his recent investigation of fraudulent claims for damages to eggs arriving in New York City over railroads from the west. H. C. Shimer and Adolph Fortgang, egg dealers, 336 Washington street, pleaded guilty and were fined \$6,000 and \$5,000, respectively, for bribing freight inspectors of the Pennsylvania and the Erie to approve the payment of excessive claims. Henry A. Guiler, assistant federal attorney, said that these defendants had collected wrongfully \$38,000 on padded claims during the past year or two. Shimer was fined an additional \$5,000 on the charge of bribing a railroad employee to give information concerning the business of competing egg dealers. DeWinter & Company pleaded guilty to attempting to induce discrimination in expeditious delivery of eggs by the payment of money to railroad employees, and a fine of \$7,000 was imposed. The government attorney believed that in twelve months DeWinter & Company had profited \$30,000 by means of these frauds.

#### California Commission Reduces Express Rates.

The California Railroad Commission has issued a decision ordering a reduction of the rates of Wells, Fargo & Company, for transportation of merchandise of approximately 15 per cent. below the present rates. It is estimated that the order will reduce the earnings of the company by \$750,000 a year. The commission has prescribed entirely new rates on a ten mile zone basis, to become effective October 1. At the end of six months the company is to submit a statement of its earnings if it feels the rates are not reasonable. In the decision the commission declares that the company makes a net yearly profit of \$842,097, or 136 per cent. on a property valuation estimated at \$613,233. The decision terms the company "a parasite on the railroads," and suggests that instead of appealing to the Interstate Commerce Commission for permission to increase rates the railroads "look into its express situation." "That somebody is getting the worst of it, there is no doubt," the commission says, and continues: "We do not see why the railroad companies, if this service is a public necessity, as it seems to be, could not furnish and maintain the comparatively small amount of additional terminal equipment which is necessary to carry on the pick-up and delivery business of the express company."

The commission also points out that the Wells Fargo company pays to the Atchison, Topeka & Santa Fe 55 per cent. of its gross earnings on that line, and to the Southern Pacific only 40.8 per cent., and comments on the fact that "neither the Santa Fe nor its principal stockholders are heavily, if at all, interested in Wells, Fargo & Company, and that the Southern Pacific officials and its principal stockholders are." The commission estimates that the Southern Pacific "in effect pays to the express company \$2,500,000 annually more than it should on all business in California."

#### INTERSTATE COMMERCE COMMISSION.

The commission has further suspended from August 4 until February 4 the operation of the certain schedules in certain boat-line tariffs, which proposed to add to the list of articles the transportation of which is prohibited, butter, eggs, fresh meats and live or dressed poultry.

The commission has further suspended from August 13 until February 13 the operation of certain schedules in supplements to Agent W. H. Hosmer's tariff, which proposed to increase rates for the transportation of building stone, C. L., from Sandstone and Banning, Minn., to Kansas City, Mo., and other destinations.

The commission has further suspended from August 13 until February 13 the operation of the supplement to the tariff of the Chicago, Rock Island & Pacific, which publishes advanced rates for the transportation of wheat and corn, C. L., from Omaha, Neb., and other Missouri River points to Mann, Spencer, Unity, Colby and Abbottsford, Wis.

The commission has suspended from August 1 until November 29 the operation of certain provisions contained in a supplement to the tariff of the Chicago, St. Paul, Minneapolis & Omaha, which cancel commodity rates applicable to the transportation of

emigrant movables between Chicago, St. Louis, St. Paul, Kansas City and other points and stations in South Dakota.

The commission has further suspended from August 9 until February 9 the operation of the supplement to tariff of the Pennsylvania Railroad, which contains schedules which advance rates for the transportation of petroleum and its products, C. L., from Emlenton, Pa., and a number of other points located on the Pennsylvania Railroad north of Pittsburgh and south of Franklin, Pa., to Detroit, Mich., Milwaukee, Wis., and other points of destination.

The commission has suspended from August 1 until November 29 the operation of an item in a supplement to W. H. Hosmer's tariff, which contains advances in rates applicable to the transportation of packing house products, in carloads, from Marshalltown, Cedar Rapids and Des Moines, Ia., to Chippewa Falls, Wis., Eau Claire, Wis., St. Paul, Minn., and other points, the increases amounting to from one to seven cents per 100 lbs. The present rate from Cedar Rapids to Eau Claire, for example, is 15 cents and the proposed rate 18½ cents per 100 lbs.

The commission has suspended from August 4 until December 2, 1913, the operation of certain schedules in a supplement to Agent A. D. Hall's tariff, which contain rates which exceed by ½ to 3½ cents per 100 lbs. the present lowest combination of local rates applicable to the transportation of flour from St. Jacob, Ill., to certain points in Kentucky and Tennessee. For example, the present rate on this traffic from St. Jacob, Ill., to Denton, Ky., is 21.5 cents per 100 lbs., the factors of which are 10.5 cents to Paducah, Ky., and 11 cents beyond; the proposed rate is 25 cents per 100 lbs.; increase 3.5 cents per 100 lbs.

#### Complaint Dismissed.

*Dillon Coal & Transfer Company v. Oregon Short Line et al. Opinion by the commission:*

Although advised by the commission that his claim informally presented would be considered only on the formal docket the petitioner took no further action for five years and then filed this complaint. The commission decided that the complaint was barred by the statute of limitations. (28 I. C. C., 81.)

#### Lagrange, Ga., Discriminated Against.

*Lagrange Chamber of Commerce v. Atlanta & West Point et al. Opinion by Commissioner Clements:*

The commission decided that the present adjustment of rates from the Ohio and Mississippi river crossings was unjustly discriminatory to Lagrange, Ga., and unduly preferential to Opelika, Ala. The defendants were ordered to remove this discrimination. (28 I. C. C., 178.)

#### Special Passenger Fares Cannot Be Ordered.

*Carnegie Board of Trade et al v. Pennsylvania Company et al. Opinion by the commission:*

Special fares for the movement of passengers in guaranteed numbers in one day, without baggage-checking privileges, may be provided by carriers under the permission given in section 22 of the act to regulate commerce. In the absence of discrimination the commission, however, has no power to prescribe such fares. (28 I. C. C., 122.)

#### Chicago-Missouri River Class Rates Unreasonable.

*Cedar Rapids Commercial Club v. Chicago, Rock Island & Pacific. Opinion by Commissioner Harlan:*

The class rates between Chicago and points on the Missouri river are adjusted on an 80-cent scale, and between Chicago and points on the Mississippi river in Iowa on scales of from 37.5 to 41.7 cents. Upon complaint on behalf of the cities in the interior of the state of Iowa the commission decided that the rates between such interior points and Chicago are unreasonable and unduly discriminatory in comparison with the rates to the river towns, and ordered carriers to submit to the commission for approval a revised basis of such rates grading the 80-cent Missouri river scale back across the state. Reparation was denied. (28 I. C. C., 76.)

REVENUES AND EXPENSES OF RAILWAYS.

MONTH OF MAY, 1913.

Name of road.	Average mileage operated during period.	Operating revenues			Maintenance			Operating expenses			Net operating revenue (or deficit).	Outside operations, net.	Taxes.	Operating income (or loss).	Increase (or decr.) comp. with last year.
		Freight.	Passenger.	Total.	Way and structures.	Of equipment.	Trans- portation.	Traffic.	General.	Total.					
Denver & Salt Lake.....	215	\$73,833	\$20,574	\$97,957	\$21,030	\$17,385	\$3,613	\$33,011	\$5,370	\$80,409	\$17,548	.....	\$1,500	\$14,048	\$21,538
Louisiana & Western.....	208	126,212	65,630	199,921	24,942	35,209	8,777	37,321	5,612	30,361	69,510	.....	7,406	62,719	15,288
Morgan's La. & Tex. R. R. & S. S. Co.....	404	262,359	101,381	369,011	69,793	59,174	10,670	179,509	12,930	336,476	52,335	.....	17,718	33,297	116,038
St. Louis & San Francisco.....	4,742	2,419,933	880,950	3,524,319	695,390	464,826	78,441	1,253,278	130,910	2,623,855	901,474	.....	165,364	736,110	109,481

ELEVEN MONTHS OF FISCAL YEAR, 1913.

Denver & Salt Lake.....	215	\$742,739	\$258,416	\$1,048,240	\$186,713	\$23,612	\$23,612	\$362,445	\$55,164	\$808,063	\$240,177	.....	\$38,500	\$201,677	\$30,551
Louisiana & Western.....	208	1,386,609	646,665	2,128,681	382,847	80,108	651,743	651,743	62,491	1,434,563	694,118	.....	83,247	610,785	171,163
Morgan's La. & Tex. R. R. & S. S. Co.....	404	2,991,553	1,063,298	4,319,349	784,954	675,095	146,956	1,860,796	131,425	3,595,226	720,123	.....	202,975	494,525	584,048
St. Louis & San Francisco.....	4,742	27,195,144	9,991,496	39,883,151	5,016,203	5,215,982	869,446	14,212,031	1,144,604	26,458,266	13,424,885	.....	1,844,848	11,580,037	1,313,548

MONTH OF JUNE, 1913.

Alabama & Vicksburg.....	143	\$91,035	\$41,867	\$144,869	\$18,468	\$42,298	\$3,712	\$48,794	\$5,428	\$118,700	\$26,169	.....	\$5,272	\$20,197	-\$6,964
Ann Arbor.....	309	277,427	113,264	426,794	53,572	94,597	13,798	163,645	10,125	335,737	51,057	.....	13,300	74,909	1,457
Atlantic Coast Line.....	8,238	4,669,583	2,120,227	7,335,179	1,019,419	1,244,549	186,899	2,159,062	187,386	4,797,074	2,538,085	.....	325,839	38,839	490
Baltimore & Ohio Chicago Terminal.....	77	.....	898	150,022	20,113	18,696	700	64,750	4,575	108,834	41,188	.....	16,052	26,119	-\$5,877
Belt Ry. Co. of Chicago.....	21	.....	32,117	259,251	24,056	29,439	654	99,240	8,776	160,115	99,136	.....	9,968	89,168	827
Bessemer & Lake Erie.....	204	1,014,650	32,117	1,058,468	84,425	169,198	8,110	218,800	13,449	494,082	564,386	.....	97,951	466,435	128,777
Buffalo, Rochester & Pittsburgh.....	576	879,717	95,714	1,015,458	134,077	195,132	13,704	311,934	18,136	691,003	364,488	.....	10,000	305,063	43,600
Canadian Pacific Lines in Maine.....	233	41,180	27,474	74,050	46,044	13,736	7,202	59,647	4,869	131,518	37,468	.....	12,039	69,507	23,936

Charleston & Western Carolina.....	341	97,709	26,828	132,675	2,683	27,002	3,646	59,568	5,593	93,126	39,549	.....	8,269	51,280	39,378
Chicago & Alton.....	1,026	776,519	371,769	1,251,248	171,441	170,826	58,966	603,368	35,063	1,154,686	98,560	.....	43,461	31,339	230,352
Chicago & Erie.....	270	327,673	65,791	438,967	22,694	70,799	2,004	216,140	13,234	354,783	75,429	.....	16,037	67,029	75,429
Chicago & Northwestern.....	7,976	4,572,586	1,820,261	7,196,027	1,448,985	839,074	92,514	2,501,460	144,786	5,033,499	2,162,528	.....	294,160	1,869,749	16,000
Chicago, Indiana & Southern.....	359	302,299	24,885	340,336	46,260	104,783	7,371	128,992	5,200	292,606	47,930	.....	15,282	33,340	14,383

Chicago Junction.....	12	5,205,453	1,785,450	7,631,916	15,884	2,671	920	84,796	3,572	107,843	65,767	.....	2,534	63,233	24,161
Chicago, Milwaukee & St. Paul.....	9,592	1,770,336	54,037	2,424,458	27,851	33,135	10,238	2,597,539	7,784	176,547	2,342,576	.....	48,103	2,061,940	150,605
Chicago, Rock Island & Gulf.....	477	827,937	433,888	1,372,608	118,434	236,200	35,170	510,103	33,771	933,678	438,930	.....	7,934	56,823	4,180
Chicago, St. Paul, Minneapolis & Omaha.....	1,744	636,711	155,808	835,368	204,349	248,242	25,820	248,242	23,885	633,129	202,239	.....	68,791	371,438	4,651
Cincinnati, New Orleans & Texas Pacific.....	337	94,556	27,173	127,695	31,916	31,916	9,197	58,329	5,918	137,071	9,376	.....	29,000	173,114	58,267

Colorado Midland.....	338	230,386	56,705	299,759	53,495	33,680	3,909	99,689	9,730	200,503	99,256	.....	5,702	94,605	16,023
Cumberland Valley.....	162	1,643,809	250,938	3,952,183	141,446	303,269	27,126	660,974	66,293	1,199,108	754,395	.....	49,700	701,266	429,432
Delaware, Lackawanna & Western.....	854	2,397,986	750,866	3,392,183	526,670	494,941	88,716	1,032,988	69,502	2,212,817	1,179,366	.....	165,000	1,040,967	114,856
Detroit & Mackinac.....	958	67,907	27,283	100,952	13,978	15,055	2,042	36,920	3,680	71,675	29,277	.....	8,419	17,750	33
Detroit & Mackinac.....	418	.....	863,761	4,605,126	324,489	724,629	115,821	1,431,247	129,217	2,725,403	1,879,723	.....	3,108	1,758,593	400,672

Detroit River Tunnel.....	2	1,190,266	41,599	1,240,339	126,035	100,050	2,564	196,099	62	15,871	90,829	.....	6,000	84,829	9,805
Duluth, Missabe & Northern.....	356	550,683	110,269	691,680	72,447	84,408	16,492	206,459	29,289	409,095	803,455	.....	72,341	742,313	12,718
El Paso & Southwestern.....	982	1,073,583	3	1,149,451	129,010	172,116	5,116	312,786	17,351	636,379	636,379	.....	35,000	245,851	21,075
Elgin, Joliet & Eastern.....	824	3,367,481	863,761	4,605,126	324,489	724,629	115,821	1,431,247	129,217	2,725,403	1,879,723	.....	47,862	465,210	85,610
Erie.....	1,988	.....	.....	.....	.....	.....	.....	.....	.....	.....	.....	.....	.....	1,758,593	400,672

Florida, East Coast.....	642	142,697	107,851	304,150	64,077	48,134	5,886	128,632	17,925	264,354	39,796	.....	32,018	5,761	48,119
Fort Worth & Denver City.....	454	221,759	115,777	357,200	61,999	82,984	7,891	144,296	14,531	311,701	45,319	.....	13,287	29,849	26,691
Grand Rapids & Indiana.....	578	255,263	155,582	410,845	78,708	86,642	14,151	193,018	16,290	388,809	23,641	.....	23,641	1,987,334	224,964
Grand Northern.....	7,752	4,881,023	1,476,491	6,797,699	1,617,650	615,499	125,597	1,804,060	244,434	4,407,240	2,390,459	.....	422,096	1,987,334	224,964

Gulf, Colorado & Santa Fe.....	1,586	615,789	233,088	946,071	131,158	192,572	26,592	416,143	43,115	809,580	136,491	.....	34,507	101,984	47,730
Indiana Harbor Belt.....	105	.....	.....	.....	42,205	35,316	3,788	111,782	7,211	200,302	38,898	.....	5,500	55,926	11,020
International & Great Northern.....	1,160	470,213	182,267	704,554	92,575	100,503	27,876	335,882	29,499	606,335	218	.....	20,000	75,437	2,034
Kanawha & Michigan.....	177	258,079	31,612	296,772	61,413	89,792	2,823	89,792	6,640	212,425	84,347	.....	7,055	67,403	15,042

REVENUES AND EXPENSES OF RAILWAYS.

MONTH OF JUNE, 1913—(CONTINUED).

Name of road.	Average mileage operated during period.	Operating revenues:				Operating expenses:				Net operating revenue (or deficit).	Outside operations, net.	Taxes.	Operating income (or loss).	Increase (or decr.) comp. with last year.	
		Freight.	Passenger.	Total.	Maintenance of way and structures, equipment.	Traffic.	Transportation.	General.	Total.						
Kansas City Southern.....	827	\$623,566	\$155,039	\$853,980	\$92,220	\$110,321	\$34,091	\$585,138	\$28,298	\$320,208	\$34,091	\$268,842	\$41,142	\$227,700	\$43,167
Lake Erie & Western.....	906	411,416	77,915	515,045	92,455	99,103	11,900	402,575	10,679	188,348	11,900	176,678	21,136	90,311	13,810
Lake Shore & Michigan Southern.....	1,872	3,099,611	1,194,538	4,877,892	722,825	1,130,781	110,551	3,444,861	88,130	1,610,281	110,551	\$19,846	150,000	1,253,877	86,866
Long Island.....	399	275,940	87,544	1,221,017	17,076	118,976	30,348	771,888	12,325	450,290	30,348	519,320	63,660	449,201	11,833
Louisiana Ry. & Navigation.....	351	114,307	27,210	151,576	25,279	24,273	5,361	124,364	5,603	63,358	5,361	27,012	4,005	23,007	4,941
Louisville, Henderson & St. Louis.....	200	63,123	32,744	103,506	19,568	13,440	3,883	79,135	4,530	37,714	3,883	24,371	10,348	14,575	14,154
Maine Central.....	1,206	542,711	327,669	1,422,991	205,664	140,758	67,787	779,228	29,601	353,418	67,787	145,763	56,486	89,276	12,695
Michigan Central.....	1,817	1,809,122	887,054	3,015,719	371,527	465,523	52,777	2,123,168	68,278	1,165,063	52,777	892,551	116,000	774,367	112,607
Minneapolis & St. Louis.....	1,586	554,572	167,257	770,024	108,426	96,818	20,121	528,327	17,553	285,409	20,121	241,697	32,701	208,973	35,279
Minneapolis, St. Paul & Sault Ste. Marie.....	3,976	1,656,941	600,998	2,414,216	449,938	352,734	57,803	1,718,672	53,441	804,756	57,803	695,544	151,439	554,276	69,308
Missouri, Kansas & Texas System.....	3,817	1,367,355	802,495	2,351,588	430,824	330,791	87,308	1,916,896	66,692	1,001,281	87,308	434,692	105,355	322,882	165,714
Mobile & Ohio.....	1,122	892,888	117,807	1,070,683	85,944	225,970	31,372	780,168	38,424	398,458	31,372	290,515	28,222	261,049	43,458
Monongahela.....	65	128,776	2,651	133,505	25,945	4,094	2,403	58,084	320	25,812	2,403	75,421	3,800	71,621	8,850
Nevada Northern.....	165	124,619	12,818	140,698	18,096	18,802	4,328	69,596	413	37,957	4,328	71,102	7,889	63,213	5,565
New York, Chicago & St. Louis.....	565	903,584	153,265	1,093,277	146,387	154,626	19,126	797,530	46,876	430,515	19,126	295,747	40,579	254,063	44,300
New York, Philadelphia & Norfolk.....	112	318,927	43,007	393,682	26,784	59,781	14,309	278,026	3,614	173,538	14,309	115,656	9,473	30,445	589
Norfolk Southern.....	562	174,021	63,545	264,194	34,563	30,126	8,734	165,238	5,613	86,202	8,734	98,956	4,811	93,664	2,870
Northern Central.....	472	793,095	239,830	1,106,922	160,402	251,758	30,918	977,785	17,592	517,115	30,918	129,137	40,475	88,659	60,923
Pennsylvania Co.....	1,751	4,690,318	905,288	6,154,779	1,117,757	1,035,631	121,836	4,549,750	89,712	2,184,814	121,836	1,605,029	244,815	1,355,202	636,113
Pennsylvania Railroad.....	4,032	11,228,158	3,291,815	15,559,936	1,896,468	3,014,171	407,785	10,938,083	216,653	5,403,006	407,785	4,621,853	584,346	3,868,935	199,691
Philadelphia, Baltimore & Washington.....	713	929,093	664,335	1,783,321	216,843	353,675	51,000	1,409,399	33,771	754,110	51,000	373,922	53,477	320,445	42,836
Pittsburgh, Cincinnati, Chic. & St. Louis.....	1,472	2,488,039	760,751	3,649,063	708,777	834,060	78,679	3,135,429	80,707	1,433,206	78,679	513,634	140,656	372,145	590,418
Richmond, Fredericksburg & Potomac.....	88	157,515	259,219	42,518	26,357	3,540	7,020	166,781	3,540	166,781	7,020	41,438	41,006	50,712	25,947
San Antonio & Aransas Pass.....	727	221,385	122,238	364,096	114,314	72,271	11,614	356,572	7,272	151,101	11,614	7,524	12,719	5,195	17,189
Seaboard.....	3,082	1,343,656	377,176	1,940,658	185,844	243,091	74,246	1,282,218	60,418	718,619	74,246	688,440	77,000	579,318	232,469
Southern.....	7,037	3,195,302	1,514,709	5,147,098	796,755	733,052	176,124	3,759,325	183,908	1,869,486	176,124	1,387,763	200,825	1,189,242	43,118
Southern in Mississippi.....	281	37,698	26,609	71,716	23,671	9,825	4,931	82,012	2,359	41,246	4,931	10,296	8,337	18,633	10,469
Union R. of Baltimore.....	9	120,418	21,846	143,937	11,609	.....	2,779	20,955	1,117	5,450	2,779	122,982	8,488	114,494	2,685
Union R. of Pennsylvania.....	31	597,571	205,393	884,223	48,995	108,017	100	163,133	60,418	718,619	100	180,087	10,000	168,318	43,347
Vandalia.....	910	45,122	84,043	108,499	3,753	13,544	1,082	84,838	1,412	43,067	1,082	23,461	3,340	20,214	1,069
Washington Southern.....	356	143,993	394,904	570,745	72,119	76,515	15,357	409,260	16,922	228,347	15,357	161,485	27,310	131,663	42,087
West Jersey & Seashore.....	31	597,571	205,393	884,223	48,995	108,017	100	163,133	60,418	718,619	100	180,087	10,000	168,318	43,347
Alabama & Vicksburg.....	143	\$1,240,791	\$491,427	\$1,861,937	\$281,033	\$371,898	\$66,960	\$1,404,598	\$43,604	\$641,409	\$66,960	\$457,339	\$69,559	\$384,811	\$90,838
Alabama Great Southern.....	309	3,488,041	1,291,317	5,231,985	627,364	1,177,997	110,471	3,815,904	154,663	1,736,400	110,471	1,416,081	176,041	1,232,664	23,453
Ann Arbor.....	292	1,381,716	549,661	2,027,720	295,141	259,188	87,215	1,435,083	49,641	743,898	87,215	637,619	167,159	461,516	63,914
Archison, Topeka & Santa Fe.....	8,238	64,547,715	25,491,140	98,090,754	15,239,198	16,317,940	2,005,392	63,830,683	2,074,835	28,193,318	2,005,392	34,260,071	4,067,432	30,192,639	1,558,678
Atlantic Coast Line.....	4,616	24,497,524	8,931,836	36,123,072	4,667,357	5,581,307	947,067	24,635,532	618,144	12,821,637	947,067	11,487,540	1,451,477	10,036,063	501,342
Baltimore & Ohio Chicago Terminal.....	77	.....	22,531	1,794,351	229,264	276,256	56,450	1,403,444	9,111	832,363	56,450	390,907	209,181	192,456	92,070
Belt Ry. Co. of Chicago.....	21	.....	3,193,208	195,307	430,158	6,196	1,331,104	68,435	2,031,104	1,162,008	100,227	1,061,781	100,227	1,061,781	105,788
Bessemer & Lake Erie.....	204	8,509,688	368,161	9,012,362	982,051	1,708,771	134,149	5,109,387	108,586	2,175,540	134,149	3,902,975	292,951	3,610,024	57,016
Buffalo, Rochester & Pittsburgh.....	576	9,411,879	1,127,612	10,947,246	1,557,963	2,161,210	224,441	7,665,891	224,441	3,281,355	224,441	3,281,355	216,000	3,057,990	183,843
Canadian Pacific Lines in Maine.....	233	983,341	379,027	1,476,484	354,705	220,616	60,677	1,372,608	74,604	662,006	60,677	103,876	124,039	20,163	92,311
Charleston & Western Carolina.....	341	1,441,549	356,357	1,895,999	321,938	313,928	50,966	1,472,594	40,289	738,532	50,966	423,405	63,269	360,136	61
Chicago & Alton.....	1,026	9,908,251	4,218,552	15,254,865	2,550,080	3,379,145	402,965	12,840,072	57,908	6,414,793	402,965	2,414,703	486,761	1,893,613	1,260,480
Chicago & Erie.....	270	4,225,158	741,783	5,493,371	896,208	1,179,828	137,553	5,325,790	252,171	2,860,029	137,553	1,67,581	166,722	9,133	443,336
Chicago & Northwestern.....	7,976	54,661,588	20,557,623	83,035,921	11,501,186	11,569,696	1,592,858	58,252,780	1,348,982	32,241,258	1,592,858	24,783,141	3,597,160	21,197,277	17,540,872
Delaware River & Chesapeake.....	359	3,936,915	303,952	4,407,458	571,382	1,120,674	115,996	3,429,995	97,171	1,524,781	115,996	277,463	195,401	787,136	316,485
Delaware Valley.....	12	.....	2,003,912	204,490	2,208,402	13,278	975,413	1,360,282	13,278	1,360,282	13,278	27,511,093	22,212	27,511,093	33,617
East St. Paul.....	9,592	67,964,161	18,457,136	94,084,055	10,498,244	13,871,986	1,403,912	62,887,594	1,894,343	35,065,842	1,403,912	27,511,093	3,823,832	27,511,093	9,239,532
Great Northern.....	477	2,487,059	697,267	3,395,974	357,132	357,132	1,224,159	2,187,524	1,224,159	1,224,159	1,224,159	31,208,450	88,744	31,208,450	9,239,532

TWELVE MONTHS OF FISCAL YEAR, 1913.

has denied.





to it by its shippers, including the Anheuser-Busch Brewing Association, instead of by the trunk lines. (28 I. C. C., 93.)

#### Carrollton, Ga., Discriminated Against.

*Board of Trade of Carrollton, Ga., et al v. Central of Georgia et al. Opinion by Commissioner Clements:*

Carrollton, Ga., is a local point on the Central of Georgia between Newnan, where the Atlanta & West Point crosses, and Cedartown, where the Seaboard Air Line intersects that road. It is less than 70 miles from Atlanta, but no direct line connects the two. Substantially, all long-distance rates to Carrollton, as well as to Atlanta, are based upon or bear relation to the rates from Baltimore, Md., and from Louisville, Ky. Atlanta has certain rates from Baltimore and from Louisville which are applied by the carriers at Cedartown, without addition or subtraction, but at Newnan and Carrollton the defendants make joint rates by adding certain differentials to the rates to Atlanta, which differentials are less than the local rates from Atlanta to Carrollton. Upon a complaint which alleges that these rates to Carrollton violate sections 1, 3, and 4 of the act, and specifically brings in question the basing-point system of rate making as applied at Carrollton, the commission held that the defendants, having filed applications to be relieved from the operation of the fourth section of the act, and determination of such applications by the commission not having been reached, this case may be decided under sections 1 and 3, reserving decision under section 4 until the commission passes upon the appropriate applications of the carriers.

The basing-point system of rate making does not now demand that joint through rates over long distances to local or non-competitive points should be made by adding to basing-point rates either the full locals or high differentials.

In the making of joint through rates on long-distance traffic to local or non-competitive points, the differentials above the rates to the basing points should bear some reasonable relation to the total distances involved, in order that the rates to the local points may be just and to avoid subjecting such local points to prejudice or disadvantage that is undue.

Where the long-haul traffic to local stations is meager, these differentials may be higher than otherwise they would be.

The present rates to Carrollton are unjust and unreasonable and subject that place to undue prejudice and disadvantage in that the defendants, in making rates on long hauls from Baltimore and related points and from Louisville and related points, add to the competitive rates to the basing point, Atlanta, differentials or arbitraries which, as component parts of joint through rates, are excessive and unreasonable when the total length of the haul is considered, and do not add such differentials or arbitraries to commercially competitive points, such as Cedartown.

In view of all the circumstances and conditions shown, differences and discriminations in rates as between Atlanta, Cedartown, and Carrollton may be justified; but the prejudice and disadvantage to which Carrollton may be subjected should not, for the present, exceed the differentials herein prescribed as maxima. Reparation was denied. (28 I. C. C., 154.)

#### Conference Rulings.

Free interstate transportation may lawfully be issued to officers of any railroad in an adjacent foreign country which has filed joint tariffs and concurrences in connection with interstate carriers in the United States without reservation as to the jurisdiction of the commission.

The Panama Railroad has not complied with the provisions of the act to regulate commerce in such a way as to make its officers and employees entitled to free transportation.

As to shipments from points in the United States to points in Mexico which are held at the border by reason of the carriers being unable to transport them to destination on account of revolutionary conditions in Mexico, the carriers will be permitted to file with the commission a proper application for authority to establish on one day's notice tariffs naming the conditions and rates under which they will return or otherwise dispose of the property which has been billed to points in Mexico and which they have been unable to deliver because of the revolutionary conditions in Mexico.

In a previous conference ruling the commission expressed the

view that a transit privilege extended through a period of more than one year is *prima facie* unreasonable. Experience has shown, however, that as applied to import shipments of matting and tea which must be purchased in foreign countries in certain seasons and in large quantities, a transit period of 18 months is not unreasonable, provided full local rates to the transit point are required to be paid.

In connection with the published privilege of feeding and grazing in transit, or where carriers are required to feed live-stock in transit, under the provision of an act approved June 29, 1906, commonly called the 28 hour law, carriers may lawfully provide in their tariffs that they will furnish feed at current market prices, and bill the cost thereof, together with an addition not exceeding 10 per cent. of such cost to cover the value of their services as advance charges.

Where there is an additional transfer or drayage charge in connection with a through shipment, the carriers' tariffs must specify what that charge shall be. If such drayage or transfer charge is absorbed, in whole or in part, by a carrier, the tariffs must show the amount of such transfer charge that will be absorbed. A drayage firm is not a proper party to a joint tariff nor is it a carrier under the provisions of the act; therefore no tariffs can properly be filed by it. There is no provision in the law which requires, and the commission has no authority to require, a carrier to confine such drayage service to one drayman or one firm of draymen. The question of who is responsible in case of loss and damage while a shipment is in charge of a truck man to whom it has been committed by the carrier is for the carrier to resolve, and not for the commission's determination.

#### Weighting Case.

*In re Investigation of Alleged Irregularities and Discrepancies in the Weighting of Freight by Carriers Subject to the Act to Regulate Commerce. Opinion by Commissioner Proby:*

Inaccuracies in weighing result in the imposition of unreasonable charges and in discrimination between shippers just as really as do differences in the freight rate itself.

The record discloses that a majority of the track scales now in use should be at once rebuilt in order to obtain reasonably accurate results. It is also apparent that many additional scales should be installed.

A modern scale, properly installed and kept in proper condition, should be accurate within at least 100 lbs., and when under test it shows a variation of 100 lbs. or more it should be considered out of order. All scales should be tested by the test car at least once in two months; in many cases every month.

Cars should never be weighed in motion coupled at both ends. They may properly be weighed in motion when uncoupled upon scales especially designed for that purpose and in charge of thoroughly competent men. Cars should not ordinarily be weighed when coupled at one end, and never unless at points where the greatest attention is paid to the condition of the scale and the competency of the weighmaster.

A prolific source of error is the wrong stenciling of the tare weight of cars; when the car weighs more than the stenciled tare the shipper loses, while when the car weighs less than the stenciled tare the shipper gains. Correction of an erroneous stenciled weight is by a proper reweighing of the car at stated times.

Inaccuracies in weighing particular commodities, such as grain, coal and lumber, discussed and various remedies considered; and criticism of certain team-track weighing made.

General rules and practices of carriers whereby large amounts of carload freight are exempted from all weighing whatsoever considered and various criticisms and recommendations thereon made.

Remedies for the defects in weighing revealed by this investigation discussed at length, and the opinion advanced that some federal tribunal, perhaps this commission, should be given authority in the following respects: To fix the points at which track scales shall be installed; to prescribe the standard of such scales and their installation; to test or supervise the testing of such scales; and to supervise the operation. (28 I. C. C., 7.)

#### STATE COMMISSIONS.

The Missouri & North Arkansas has filed an application with the Missouri Public Service Commission, asking for author-

ity to increase its passenger rate to three cents a mile, and to charge freight rates higher than those required by the maximum freight rate law. The road contends that the two cent passenger and maximum freight rates are confiscatory.

**COURT NEWS.**

In the United States District Court at Pittsburgh, Pa., August 1, the Pennsylvania Railroad was fined \$4,000 for thirty-four violations of the hours of service law. The company pleaded guilty to all but seven of the thirty-four violations charged.

Hearings in the suit of the state of Texas against the Missouri, Kansas & Texas, attacking the constitutionality of the act passed at the last session of the legislature authorizing the consolidation of various subsidiary lines of the Missouri, Kansas & Texas, were begun before a commissioner at Dallas on July 30. President C. E. Schaff, General Manager W. A. Webb, and General Freight Agent L. J. West testified regarding the organization of the various lines.

The Terminal Railroad Association of St. Louis has filed with the Federal Court at St. Louis a form of proposed reorganization as ordered by the United States Supreme Court. The proposed plan provides for the abolition of the arbitrary within the so-called 100-mile zone, permits of any common carrier enjoying the privileges of the Terminal's tracks and terminal facilities and otherwise conforms to the mandate of the Supreme Court. E. C. Crow, special representative of the Government, is now working on a form of decree which he will submit to the court, in which the arbitrary will be given special attention. The instrument now filed by the company permits a railroad to become either a joint owner of the property through assessment of cost of operation and maintenance or to enjoy the privileges at a fee to be agreed upon, any controversy arising from the agreement between the Terminal and lines applying to trackage rights to be submitted to the court for adjudication. Rebilling of freight originating in St. Louis from East St. Louis is done away with, and that section of the company's rules prohibiting any member of the association or road using its facilities from taking advantage of any other terminal facilities is annulled.

**Iowa Passenger Fare Law Enjoined.**

United States Judges Smith, McPherson and Van Valkenberg at Council Bluffs, Ia., on August 2, rendered a decision granting a permanent injunction against the enforcement of a passenger rate of 1½ cents a mile for the State Fair at Des Moines, which was prescribed in a law passed by the last session of the state legislature. The decision holds that the rate is confiscatory, and discriminates in favor of Des Moines as against other cities in the state.

**INDIAN RAILWAY MILEAGE.**—During the calendar year of 1912, 668 miles of new line were opened to traffic in India, bringing the total mileage in operation up to 33,484 miles. This figure comprises 17,189 miles of 5 ft. 6 in. gage; 14,165 miles of 3 ft. 3 in. gage; 1,692 miles of 2 ft. 6 in. gage, and 438 miles of 2 ft. gage.

**RAILROAD NEWS.**—The steam car South Carolina arrived at Charleston at half-past seven p. m. on the 15th from Branchville, 62½ miles, in 7 hrs. 15 min., all stoppages included. Eighteen passengers; cargo 70 bales of cotton. Stopped at Summerville 30 min. to discharge freight cars.—*American Railroad Journal, January 5, 1833.*

**NEW STEAM CARRIAGE.**—A steam carriage constructed by Col. Macirone and J. Squire, Paddington-wharf, and which professes to be by the superiority of its peculiar boiler, and the simplification of its machinery, a decided improvement on all former vehicles of that description, has been exhibited for some time past in the neighborhood of Paddington. We drove out in it a few days ago along the Harrow-road with, in all, 11 persons. The utmost velocity on level ground was near 10 miles an hour; a part of the road covered with a coating of loose wet pebbles was crossed at a rate of about eight miles; and the bridge over the Grand Junction Canal, where the steep is rather a smart one, at four or five miles an hour.—*Quotation from the London Times in the American Railroad Journal, January 19, 1833.*

**Railway Officers.**

**Executive, Financial and Legal Officers.**

J. B. McLaren, has been appointed auditor of freight accounts of the Grand Trunk, with office at Montreal, Que., in place of J. D. McLennan, assigned to other duties.

W. P. Hopper, local treasurer of the Georgia Southern & Florida, at Macon, Ga., has been appointed also secretary and treasurer of the Hawkinsville & Florida Southern.

J. E. Hall, general counsel of the Georgia Southern & Florida, has been appointed also vice-president and general counsel of the Hawkinsville & Florida Southern; office at Macon, Ga.

W. B. Buchannon, auditor of the Georgia Southern & Florida and the Macon & Birmingham, has been appointed also auditor of the Hawkinsville & Florida Southern; office at Macon, Ga.

V. L. Veasey has been appointed auditor of the Texas State Railroad, with headquarters at Rusk, Tex., in place of J. A. Shattuck, resigned to accept a position with the International & Great Northern.

J. S. Pyeatt, vice-president and general manager of the New Orleans, Texas & Mexico and the Beaumont, Sour Lake & Western, and vice-president of the Orange & Northwestern and the St. Louis, Brownsville & Mexico, has been appointed manager for the receiver of the St. Louis, Brownsville & Mexico, the Beaumont & Sour Lake and the Orange & Northwestern, with headquarters at Houston, Tex.

The executive committee of the Northern Pacific announces that after having carefully considered the situation created by the impending retirement from the presidency of the company by Howard Elliott, the committee has decided to recommend to the board of directors the following plan for meeting it:

"Creation of the office of chairman and promotion of W. P. Clough, now first vice-president, to fill the same.

"Promotion of J. M. Hannaford, now second vice-president, to be president.

"Promotion of G. T. Slade, now third vice-president, to be first vice-president."

Edson Prosper Rich, who recently was made assistant general solicitor of the Union Pacific, in addition to his duties as general attorney for the states of Iowa and Nebraska, as has already been

announced in these columns, was born August 15, 1858, at Griggsville, Ill. He was graduated from the University of Nebraska in 1884 and took a post-graduate course at the Johns Hopkins University in 1884-1885. Mr. Rich was made assistant attorney of the Union Pacific for Nebraska in 1900, and from 1903 to 1904 he held the position also of general claims attorney for the entire system. In 1908 he was appointed general attorney for the states of Iowa and Nebraska, and effective July 1 this year he was made assistant general solicitor, still retaining the title of general at-



Edson Rich.

torney for Iowa and Nebraska, as above noted. The headquarters of Mr. Rich are at Omaha, Neb.

John H. Hunter has been chosen president of the Brinson Railway, with office at Savannah, Ga., in place of Geo. M. Brinson. The board of directors of this road has been reorganized as follows: James Imbrie, Thomas P. Goodbody and John F. Wallace of New York; Mills B. Lane, John H. Hunter, Robert M. Hitch and Henry D. Stevens of Savannah, and E. T. Comer of Millhaven. The new board elected James Imbrie, chairman;

Robert M. Hitch, secretary, and William Murphy, assistant secretary.

J. M. Johnson, vice-president in charge of traffic of the Missouri Pacific and the St. Louis, Iron Mountain & Southern, who has been appointed vice-president in charge of traffic also of the Western Pacific and the Denver & Rio Grande, as recently announced in these columns, was born May 13, 1845, at Cincinnati, Ohio. He was educated in the public schools, and began railway work January 1, 1871, as station agent for the Indianapolis, Cincinnati & Lafayette at Franklin, Ind. He was successively general freight and ticket agent of the Cincinnati & Martinsville and traveling auditor of the Indianapolis, Cincinnati & Lafayette until 1877, when he was placed in charge of the local freight traffic of the latter road. From November, 1879, to January, 1883, he was assistant general freight agent of the Indianapolis, Cincinnati & Lafayette and the Cincinnati, Lafayette & Chicago at Lafayette, Ind. He was then made assistant general freight agent of the Cincinnati, Indianapolis, St. Louis & Chicago in charge of freight traffic originating in Chicago and the Northwest, and on March 1, 1884, went to the Chicago, Rock Island & Pacific as first assistant general freight agent. Four years later he was promoted to general freight agent of that road; from March, 1896, to March, 1899, was freight traffic manager, and on the latter date he became third vice-president. Mr. Johnson left the Rock Island on April 1, 1903, to accept the position of assistant to the vice-president of the Gould Lines, and on November 1, 1907, he was made vice-president in charge of traffic of the Missouri Pacific and the St. Louis, Iron Mountain & Southern, with headquarters at St. Louis, Mo. His jurisdiction is now extended over the Western Pacific and Denver & Rio Grande, as above noted.



J. M. Johnson.

#### Operating Officers.

W. B. Allen has resigned as superintendent of transportation of the Chesapeake & Ohio of Indiana.

J. E. Duval has been appointed general superintendent of car service of the Grand Trunk, with office at Montreal, Que.

J. H. Conlan has been appointed general roadmaster of the Colorado lines of the Denver & Rio Grande, with office at Denver, in place of P. C. Connelly, resigned.

J. W. Forgason has been appointed assistant superintendent of the Victoria division of the Galveston, Harrisburg & San Antonio, with office at Victoria, Tex.

I. C. Schreck, heretofore on the Cleveland division, has been appointed train master of the Michigan division of the Cleveland, Cincinnati, Chicago & St. Louis, with office at Wabash, Ind.

James Doyle has been appointed assistant superintendent of the First division of the Houston & Texas Central, with office at Ennis, Tex., in place of H. M. Torrance, assigned to other duties.

B. C. Beyers has been appointed superintendent of the Peoria & Eastern division of the Cleveland, Cincinnati, Chicago & St. Louis, in place of M. E. Neville, promoted; office at Indianapolis, Ind.

W. F. Kaderly, superintendent of motive power of the Georgia Southern & Florida and the Macon & Birmingham, has been appointed general superintendent of the Hawkinsville & Florida Southern, with office at Macon, Ga.

J. H. Palmer, heretofore general manager of the Gulf Line, with office at Ashburn, Ga., becomes, under the new organization of the road, now the Hawkinsville & Florida Southern, superintendent and car accountant, with office at Ashburn.

E. S. Koller, assistant general manager of the Chicago, Burlington & Quincy, with headquarters at Chicago, has been appointed assistant general manager of the lines west of the Missouri River, with headquarters at Omaha, Neb.; effective August 1.

H. W. Sheridan, general superintendent of the Louisiana Western and Morgan's Louisiana & Texas Railroad & Steamship Company, with headquarters at New Orleans, La., has resigned. Guy Hopkins has been appointed acting general superintendent in place of Mr. Sheridan.

J. A. Brown, assistant general freight agent, and C. W. Strain, assistant general passenger agent, of the St. Louis, San Francisco & Texas, Ft. Worth & Rio Grande, Brownwood, North & South and the Paris & Great Northern, have resigned, and the positions are abolished. Mr. Brown and Mr. Strain will retain their present positions with the south Texas lines of the Frisco.

S. S. Butler, heretofore assistant to the vice-president, in charge of traffic, of the Texas and Louisiana lines of the St. Louis & San Francisco, has been appointed traffic manager of the St. Louis, Brownsville & Mexico, Beaumont, Sour Lake & Western and the Orange & Northwestern, with headquarters at Houston, Tex. The offices of J. E. Springer, industrial agent, and F. W. Green, immigration agent, have been abolished.

F. P. Brady, general superintendent of the Canadian Government Railways, announces that L. S. Brown has been appointed superintendent of the Truro, Sydney and Oxford district of the Intercolonial in place of Y. C. Campbell, transferred; office at New Glasgow, Nova Scotia; and that H. B. Fleming has been appointed assistant superintendent of the National Transcontinental Railway between Moncton, N. B., and Edmundston.

George E. Patterson, whose appointment as superintendent of the Springfield division of the Illinois Central, with headquarters at Clinton, Ill., has already been announced in these columns,

was born June 23, 1869, in Marion County, Illinois. He received a common school education and began railway work in October, 1889, with the Illinois Central as agent and operator at Laclede, Ill. During the next 14 years he was employed as agent and operator at various points, including Mattoon, Gilman, Rantoul, Champaign and Kankakee, Ill., and was then for one year yardmaster at Kankakee. In June, 1904, he was made division agent of the Illinois division, and the following May he became inspector of weights for the Illinois Central and the Yazoo & Mississippi Valley. Mr.



G. E. Patterson.

Patterson was appointed trainmaster at Freeport in January, 1906, and was transferred to the Chicago district in a similar capacity in August, 1907, holding the latter position until July 15, when he was promoted to the superintendency of the Springfield division, as above noted.

M. Dailey, whose appointment as general manager of the Muscatine North & South was announced in the *Railway Age Gazette* last week, was born at Galesburg, Ill., March 7, 1865, and began railroad work on the Chicago, Burlington & Quincy, at Creston, Iowa, in 1880. When twenty years old he was a locomotive engineer. In 1888 he left the service of the Burlington and took a position as locomotive engineman on the Chicago Great Western.

After two years at this work he was promoted to the position of roundhouse foreman at Des Moines, and later was made traveling engineer, trainmaster, master mechanic, and, finally, superintendent. In 1911 he left the Chicago Great Western and went to Bellingham, Wash., as superintendent of machinery of the Bellingham Bay & British Columbia. After one year's service with this company he resigned and went to the Missouri, Kansas & Texas, where he was assistant superintendent, with headquarters at Parsons, Kan. This position he resigned on his recent appointment to the M. N. & S.

Macy Nicholson, whose appointment as assistant general superintendent of the Great Northern, with headquarters at Great Falls, Mont., has already been announced in these columns, was born in October, 1874, at Hagerstown, Ind. He was educated in the common schools at Hagerstown, and began railway work in October, 1891, with the Milwaukee, Lake Shore & Western as clerk in the superintendent's office at Ashland, Wis., remaining with the road and the Chicago & North Western (which absorbed the former company in August, 1893) until June, 1896. He was then for two years employed as bookkeeper and stenographer for the Rockefeller and United States Steel mines on the Gogebic iron range in upper Michigan. He returned to active railway service in June, 1898, as clerk in the office of James J. Hill, then president of the Great Northern. In April of the following year Mr. Nicholson was made chief clerk to the vice-president and general superintendent, and from February, 1903, to May, 1905, he was an assistant superintendent. On the latter date he was advanced to division superintendent, and was successively in charge of the Dakota, Butte and Fergus Falls divisions until July 20 of this year, when he was promoted to assistant general superintendent of the Central district, as above noted.

**Traffic Officers.**

John A. Morgan has been appointed general agent of the Scott City Northern at St. Louis, Mo.

E. H. Stockton has been appointed soliciting freight agent of the Norfolk & Western at Winston-Salem, N. C.

S. Y. Henderson, has been appointed commercial agent of the Hawkinsville & Florida Southern at Hawkinsville, Ga.

C. A. Smith has been appointed assistant general freight agent of the Carolina, Clinchfield & Ohio, with office at Johnson City, Tenn.

W. T. Peacock has been appointed general agent of the Cleveland, Cincinnati, Chicago & St. Louis at Indianapolis, Ind., in place of C. H. Jackson, resigned.

E. A. Niswonger has been appointed commercial agent of the Cleveland, Cincinnati, Chicago & St. Louis at Terre Haute, Ind., in place of W. W. Baum, transferred.

T. W. Trelford, Jr., traveling freight agent of the International & Great Northern, has been appointed commercial agent at San Antonio, Tex., in place of P. A. Sullivan, resigned.

J. A. Craig, freight claim agent of the Georgia Southern & Florida, has been made also freight claim agent of the Hawkinsville & Florida Southern, with office at Macon, Ga.

M. S. Kerley has been appointed traveling freight agent of the St. Louis Southwestern, with headquarters at Shreveport, La., in place of S. A. Martin, resigned to accept service elsewhere.

J. M. Cutler, general freight agent of the Georgia Southern & Florida and the Macon & Birmingham, has been appointed also general freight agent of the Hawkinsville & Florida Southern; office at Macon, Ga.

C. B. Rhodes, general passenger agent of the Georgia Southern & Florida and Macon & Birmingham, has been appointed also general passenger agent of the Hawkinsville & Florida Southern, with office at Macon, Ga.

William J. Faherty, contracting freight agent of the Wabash at Chicago, has been promoted to contracting freight agent at New York, succeeding F. D. Royce, who has been appointed commercial agent at Philadelphia, Pa. J. L. Craig, traveling freight agent at Toledo, O., has been transferred to Chicago in a similar capacity, succeeding H. W. Chandler, assigned to other duties.

A. E. Allen, heretofore chief clerk to the traffic manager, has been appointed assistant general freight agent of the Boston & Albany, with office at Boston, Mass., in place of W. A. Barrows, promoted. Mr. Allen was born at Harwichport, Mass., September 19, 1874, and entered railroad service in 1897 as a clerk in the office of the commercial agent of the Boston & Albany at Boston. His whole railroad service has been with that company. He was made chief clerk to the general freight agent in 1906, and since June 5, 1911, has held the position from which he is now promoted.

Frank A. Wadleigh, general passenger agent of the Denver & Rio Grande, has been appointed passenger traffic manager of that road and the Western Pacific, with headquarters at Denver, Colo. E. L. Lomax, passenger traffic manager of the Western Pacific, has been appointed assistant passenger traffic manager of that road and the Denver & Rio Grande, with office at San Francisco, Cal. A. S. Hughes, general traffic manager of the Denver & Rio Grande, will have jurisdiction also over the Western Pacific, with headquarters at Denver. H. M. Adams, freight traffic manager of the Western Pacific, has had his jurisdiction extended over the Denver & Rio Grande, with headquarters at San Francisco.

J. N. Githens, freight traffic manager of the Missouri Pacific and the St. Louis, Iron Mountain & Southern, has been appointed assistant to J. M. Johnson, vice-president in charge of traffic of those roads and the Denver & Rio Grande and Western Pacific, with headquarters at St. Louis, Mo. C. E. Perkins, assistant general traffic manager of the Missouri Pacific and the St. Louis, Iron Mountain & Southern, succeeds Mr. Githens as freight traffic manager, and the former position is abolished. W. I. Jones, assistant general freight agent of the Missouri Pacific and St. Louis, Iron Mountain & Southern, has been appointed assistant to the general traffic manager, with headquarters at St. Louis. Effective August 1. A photograph and sketch of Mr. Perkins were published May 30, 1913, page 1203.

Walter A. Barrows, heretofore assistant general freight agent, has been appointed general passenger agent of the Boston & Albany, with office at Boston, Mass., in place of A. S. Hanson,



W. A. Barrows.

deceased. Mr. Barrows was born in Camden, Me., July 31, 1867. He entered the service of the Boston & Albany in March, 1892, as a clerk in the office of the ticket auditor at Boston. He subsequently served in a similar capacity in the office of the freight auditor and of the general freight agent; and after the lease of the Boston & Albany to the New York Central, he was for a short time employed in the office of the freight claim agent in New York City. On February 2, 1903, he was appointed eastbound contracting freight agent at Boston; on August 1, 1906, was promoted to

division freight agent at Pittsfield, and on December 1, 1907, was made division freight agent at Worcester. On April 1, 1913, he was made assistant general freight agent, with office at Boston, which place he held at the time of the promotion now announced. Mr. Barrows was graduated from Yale college in the class of 1891.

The traffic department of the Intercolonial announces the following appointments, effective August 1:

D. A. Storey, general freight agent, has his authority extended over the Prince Edward Island Railway.

H. H. Melanson, acting general passenger agent, is made general passenger agent, with office at Moncton, N. B. E. Tiffin is appointed general western agent, at Toronto. H. H. Schaefer, division freight agent at Moncton, has charge of the territory

in New Brunswick, north and east of Moncton. S. G. Tiffin, Moncton division freight agent, has charge of the territory in New Brunswick west of Moncton. D. M. Condon, heretofore acting district passenger agent, is appointed district passenger agent at Halifax, N. S. D. McDonald is appointed district passenger agent, with office at Montreal.

#### Engineering and Rolling Stock Officers.

I. M. Page has been appointed signal supervisor of the Chicago & Alton at Bloomington, Ill., in place of R. D. Boynton, resigned.

J. L. Cunningham has been appointed master mechanic of the Philadelphia, Baltimore & Washington, with office at Wilmington, Del., in place of C. G. Turner, resigned.

The office of superintendent of motive power of the New Orleans, Texas & Mexico and the St. Louis, Brownsville & Mexico, heretofore held by C. M. Hoffman, has been abolished.

W. T. Cousley, chief car inspector of the Elgin, Joliet & Eastern, at Gary, Ind., has been appointed master car builder of the San Antonio & Aransas Pass, with headquarters at San Antonio, Tex.

C. L. McIlvaine has been appointed master mechanic of the New York, Philadelphia & Norfolk, with office at Cape Charles (City, Va., in place of J. L. Cunningham, who has been appointed to a similar position on the P. B. & W.

E. M. Wilcox, division general foreman of the Chicago, Indiana & Southern and the Indiana Harbor Belt, has been appointed division general foreman of the Lake Shore & Michigan Southern, with headquarters at Englewood, Ill., succeeding George Thomson, promoted.

#### Purchasing Officers.

Samuel Porcher, whose appointment as purchasing agent of the Pennsylvania Railroad, with office in Philadelphia, Pa., has been mentioned in these columns, was born in South Carolina on December 21, 1857. He was educated at the University of Virginia, graduating in the class of 1881. On January 27, 1882, he began railway work as an apprentice in the Altoona shops of the Pennsylvania Railroad. He went through a full shop course, including the test department, remaining in the mechanical department of the Pennsylvania Railroad at Altoona until 1888. From 1888 to 1894 he was assistant engineer in the motive power department of the United Roads of New Jersey division of the Pennsylvania Railroad with office in Jersey City, N. J. On March 1, 1894, he was appointed assistant purchasing agent of the Pennsylvania Railroad with office in Philadelphia, which position he retained until his appointment as purchasing agent of the Pennsylvania Railroad, as mentioned above.



Samuel Porcher.

**TRANSPORTATION IN MADRAS.**—It is suggested that the needs of better transportation facilities in the Madras presidency might be met, in the absence of railway extensions, by putting industrial motors on the roads. A Madras correspondent of an Indian contemporary remarks that the leap from railways to motor traffic is easy and that the increased utilization of road traction would be justifiable, if only from the point of view of not putting all your traffic eggs in one basket. The demand for more ample traveling and freight car facilities forms one of the principal themes at the meetings of the District Boards. It is constantly coming under the consideration of trades people and of their Chambers of Commerce. The need is universal and insistent.

## Equipment and Supplies.

### LOCOMOTIVE BUILDING.

THE NORFOLK & WESTERN is in the market for 10 Pacific type locomotives.

THE BARTLETT WESTERN has ordered 1 mogul locomotive from the Baldwin Locomotive Works.

THE PERE MARQUETTE has ordered 10 mikado locomotives from the Baldwin Locomotive Works.

THE PAULISTA RAILWAY, Brazil, has ordered 2 prairie locomotives from the Baldwin Locomotive Works.

THE CUBAN AMERICAN SUGAR COMPANY has ordered 1 mogul locomotive from the Baldwin Locomotive Works.

THE CANADIAN NORTHERN is making inquiries for 15 consolidation locomotives and 15 switching locomotives.

THE CHICAGO & EASTERN ILLINOIS has ordered 2 Pacific type locomotives from the American Locomotive Company. These locomotives will be equipped with superheaters, will have 26½ in. x 28 in. cylinders, 73 in. driving wheels and in working order will weigh 272,000 lbs.

THE CUBAN CENTRAL has ordered 3 ten-wheel locomotives, 4 consolidation locomotives and 1 six-coupled double end tank locomotive from the American Locomotive Company. The ten-wheel locomotives will be equipped with superheaters, will have 18 in. x 24 in. cylinders, 56 in. driving wheels, and in working order will weigh 118,000 lbs. Three of the consolidation locomotives will be equipped with superheaters, will have 18 in. x 24 in. cylinders, 50 in. driving wheels, and in working order will weigh 125 lbs.; and the other consolidation locomotive will have 16 in. x 20 in. cylinders, 38 in. driving wheels, and in working order will weigh 101,000 lbs. The six-coupled double end tank locomotive will have 17 in. x 24 in. cylinders, 50 in. driving wheels, and in working order will weigh 106,000 lbs.

### CAR BUILDING.

CHICAGO & ILLINOIS MIDLAND is in the market for 250 gondola cars.

THE CHARLOTTE HARBOR & NORTHERN is in the market for 50 flat cars.

THE NORFOLK & WESTERN is building 700 ninety-ton gondola cars at the company's shops.

THE NEW YORK CENTRAL LINES are making inquiries for 400 steel underframes for heavy repairs to freight cars.

THE LEHIGH VALLEY has ordered 500 steel underframes from the Standard Steel Car Company for heavy repairs to cars.

### SIGNALING.

The New York, New Haven & Hartford is gradually installing on its four track lines automatic block signals in place of the controlled manual system. Automatics have already been put in use between Stamford and South Norwalk, 9 miles, and the work is to be extended eastward to Bridgeport and then to New Haven; and the whole line, Stamford to New Haven, about 40 miles, is expected to be equipped by the first of next January. Work has been begun on the substitution of semaphores for the enclosed disk signals on the double track line from New Haven to Springfield, 62 miles. Three-position semaphores are to be used on this division and the arms will move in the upper left hand quadrant. Alternating current is to be used in all of the new signals for track circuits, for signal circuits and for lighting. On the line from New Haven to Stamford, there will be duplicate wires for supplying current, one circuit being supported on the south side of the roadway and the other on the north side, this to provide as effectually as possible against interruptions of service from loss of tower. Independent signal generating units are to be put in at the Cos Cob power house.

## Supply Trade News.

The Hall Switch & Signal Company, New York, opened a branch office in the New Birks building, Montreal, Que. B. H. Richards will have charge. Heretofore all the Canadian business of this company has been handled through the New York office.

J. C. Tipton has been made Canadian representative of the Galena Signal Oil Company, New York, with office in Montreal, Que., succeeding A. Lichtenhein, deceased. After September 1, the Montreal office of this company will be located in the Shaughnessy building.

The Taylor-Wharton Iron & Steel Company, High Bridge, N. J., has opened a branch office in the Candler building, Atlanta, Ga., in charge of H. F. McDermott, as engineer and district sales manager. This office will also be a branch office of Wm. Wharton, Jr., & Co., Inc., Philadelphia, Pa.; the Tioga Steel & Iron Company, Philadelphia, and the Philadelphia Roll & Machine Company, Philadelphia.

L. C. Noble, vice-president of the Pittsburgh Spring & Steel Company, whose death at his home in Evanston, Ill., was noted in our issue of July 25, was born at Ann Arbor, Mich., July 24,



L. C. Noble.

1842. In October, 1862, he became foreman of the machine shop of the Detroit Locomotive Works, holding that position until 1863. From 1863 to 1867, he was employed in the shops of the Chicago & North Western at Chicago. From 1872 to 1874, he was general foreman of the Houston & Texas Central, and in May, 1874, was appointed general master mechanic for the same road. Subsequently he was for several years prior to 1890 superintendent of motive power of the same road. In 1890 he became associated with the A. French Spring Company, as western manager of sales, and in 1902 he resigned that position to become vice-president of the Pittsburgh Spring & Steel Company, with office at Chicago, which position he held at the time of his death.

### TRADE PUBLICATIONS.

**CONCRETE WORK.**—The Pittsburgh Testing Laboratory, Pittsburgh, Pa., has issued booklet C of specifications for cement, reinforcement bars and concrete.

**COMPRESSORS.**—The Chicago Pneumatic Tool Company has issued bulletin 34 R, describing its class L-SS and L-SB compressors of the enclosed self-oiling type.

**COUPLERS.**—The Robinson Coupler Company, Washington, D. C., has published an attractive booklet illustrating and pointing out the advantages of the Robinson Connectors.

**CULVERTS.**—The Portsmouth Culvert Company, Portsmouth, Ohio, has issued an illustrated booklet describing the manufacture and use of its Butt-Joint Nestable corrugated metal culverts, including descriptions of various installations.

**MOTOR CARS.**—The Chicago Pneumatic Tool Company has issued an illustrated booklet describing the Rockford railway motor cars of various types, and including some interesting figures showing the actual costs of operation of the Rockford cars in service.

## Railway Construction.

**ANTHONY & NORTHERN.**—This company has completed its six-mile line from a connection with the Chicago, Rock Island & Pacific at Pratt, Kan., to a connection with the Missouri Pacific at Iuka, Kan. This line will be extended north from Iuka in the near future.

**DAYTON, MIDDLETOWN & CINCINNATI (Electric).**—An officer writes that this company will build from Dayton, Ohio, to Cincinnati via Carlisle, Germantown, Middletown, Monroe, Bethany, West Chester, Sharonville and Reading. The line will be about 55 miles long and will run north and south. The prospects of building are excellent, but no track has been laid as yet. Surveys are now being made. The route is good, free from flood danger, and is almost an air line. James G. Miller, West Chester, is president, and E. H. McKnight, Middletown, is general manager.

**DENVER & SALT LAKE.**—This company will begin laying rails within a few days on its extension from Steamboat Springs to Craig, and expects to have the line completed about September 20. Grading is 95 per cent. finished from Steamboat Springs to Hayden, and is entirely finished from Hayden to Craig.

**KINGSTON & EXCELSIOR SPRINGS (Electric).**—An officer writes that this company will build a line from Kingston, Mo., southwest to Excelsior Springs, via Elmira and Lawson, about 25 miles. The prospects of building are good, but the preliminary surveys have not been completed as yet. The work will be comparatively light, the maximum grade being 2 per cent. and the sharpest curve 3 degrees. The line will carry grain, hay, live stock, stones, coal and passengers. E. S. Boner, Kingston, is president, and F. Cawood Rogers is chief engineer.

**MOTLEY COUNTY.**—An officer writes that work is under way on the line of this company from a point 3½ miles east of Roaring Springs, Tex., to Matador, 8 miles. Six miles of grading has been finished, but no track has been laid as yet. Frank Fennen, of Matador, has the contract for grading. The work is light, the maximum grade being 0.9 per cent., and the sharpest curve 3 degrees. There will be four trestles with an average length of 50 ft. The road will carry cotton, coal, lumber and general merchandise. The line will be eventually extended to Memphis on the Fort Worth & Denver City on the north and to Spur, Tex., on the south, a total distance of 120 miles.

**NEW YORK SUBWAYS.**—The New York Public Service Commission for the First district has executed a contract with the E. E. Smith Contracting Company for the construction of that section of the Broadway-Manhattan subway lying between Union Square and Twenty-sixth street. The total amount of the Smith company's bid was \$2,056,702.50. The plans call for a four track underground railroad with one-half of the express station at Union Square and a local station at Twenty-third street and Madison Square.

**PAWHUSKA & NORTH EASTERN.**—An officer writes that this company will build from Pawhuska, Okla., to Caney, Kans., and also to Skedee, Okla. No track has been laid as yet, but three miles of grading has been finished. The country to be traversed is level and the maximum grade will be 1 per cent. The amount of earth to be moved will not exceed 8,000 cu. yds. per mile. The sharpest curve will be 10 deg. There will be three bridges varying in length from 80 ft. to 120 ft. There will be no tunnels and only a few trestles. The principal commodities to be carried in order of their importance according to the amount of revenue resulting, are cattle, farm products, and other merchandise. J. B. Tolson is president.

**SAN ANTONIO, UVALDE & GULF.**—An officer writes that the earth to be moved on the extension of this company's line from Pleasanton, Tex., south to Corpus Christi, via Mathis, will average about 20,000 cu. yds. per mile. The grade will be 0.5 per cent. and the maximum curve will be 3 degrees. The streams through this territory rise rapidly, and as a result the construction will be expensive. There will be eight steel bridges varying in length from 100 ft. to 400 ft. The bridge over the Medina river, it is said, will be the highest pile bridge ever driven in Texas. The road will carry cattle, cotton, onions, corn, hay and

produce. A. R. Ponder, San Antonio, Texas, is president, and E. R. Breaker, Pleasanton, is chief engineer.

**SURPRISE VALLEY RAILWAY.**—Incorporated in Utah to build from Reynard, Nev., on the Western Pacific, to the state line of Nevada and California at the southern end of Surprise valley, about 55 miles. When this line has been completed the incorporators will organize another company and build from the northern terminus through the Surprise valley to Cedarville, Cal., 35 miles. The incorporators are F. E. Bush, president; J. E. Sexton, chief engineer, both of Palisade, Nev.; John Fritz, Geo. C. Turner and H. L. Merryfield, all of Cedarville; and H. L. Rood, E. L. Perkes and G. E. Walker, all of Salt Lake City, Utah.

**WASHINGTON & OLD DOMINION.**—Surveys have been made for the proposed extension of this company's line from Bluemont, Va., to Berryville, where a connection with the Norfolk & Western will be made, and from Berryville to a connection with the Baltimore & Ohio at Winchester.

### RAILWAY STRUCTURES.

**BLACK ROCK, N. Y.**—The Grand Trunk is planning to build a new passenger station and freight depot at this point. As planned at present, the passenger station will be built south of the track and abutting on the Niagara Street subway, and the freight station will be built just opposite on the north side of the track. The passenger station will be about 150 ft. x 40 ft., with a brown stone foundation and two stories of brick. The freight depot will be similar in size and general construction. The estimated cost of the two buildings is \$75,000.

**EAST ST. LOUIS, ILL.**—The St. Louis Southwestern, through a newly incorporated subsidiary called the Valley Terminal Association, has purchased about 140 acres of land on which to erect a roundhouse, shops and other terminal buildings, and a yard with a capacity of about 5,000 cars.

**GLENWOOD, PA.**—The Baltimore & Ohio has given a contract to the Dravo Contracting Company, Pittsburgh, Pa., for the substructure of a double track steel bridge at this point. The bridge will be 1,000 ft. long and the contract for the superstructure will be let in the near future.

**LOS ANGELES, CAL.**—The Atchison, Topeka & Santa Fe Coast Lines have awarded a contract for a "Unit-Bilt" reinforced concrete 25-stall roundhouse at Redondo Junction, near Los Angeles, to the Van Sant Houghton Company of San Francisco.

**NEW HAVEN, CONN.**—The New York, New Haven & Hartford will renew four bridges on its line between East Hartford, Conn., and Springfield, Mass. Two will be at Hazardville, one at Broad Brook, and one at Springfield. The new bridges will be capable of bearing 200,000 lbs. carweight, while the bridges they will replace are capable of a carweight limit of only 100,000 lbs. On the Rockville Branch, three bridges near Vernon, will be reconstructed to bear a 156,000 lbs. carweight, and on the line from Hartford, steel bridges capable of sustaining 200,000 lbs. carweight will replace the present wooden bridges at Millville Heights, East Thompson, East Douglass, Thompson and Putman.

**REDONDO JUNCTION, CAL.**—The Atchison, Topeka & Santa Fe has given a contract to the Van Sant Houghton Company, San Francisco, Cal., for the construction of a Unit-Built reinforced concrete, 25-stall roundhouse at this point.

**SILSBEE, TEX.**—The Gulf, Colorado & Santa Fe has asked bids on an eight-stall brick and concrete roundhouse.

**TEMPLE, TEX.**—The Atchison, Topeka & Santa Fe will begin work immediately on a new roundhouse at this point to cost about \$25,000.

**TEXARKANA, TEX.**—The St. Louis Southwestern has begun work on a new 16-stall roundhouse at this point.

**TORONTO, ONT.**—The Canadian Pacific will build another addition to its passenger car repair shop at this point. The new building will be one story high and will be built of brick and concrete foundation. John Hayman & Son Company, London, Ont., have secured the concrete contract for this building, which will cost about \$26,000.

## Railway Financial News.

**CHICAGO, TERRE HAUTE & SOUTHEASTERN.**—Holders of the \$6,500,000 income mortgage bonds are to receive 1¼ per cent. on coupon No. 9, dated September 1, 1913. The interest on these bonds was a non-cumulative 4 per cent. rate up to December 1, 1912, and semi-annual payments of 1 per cent. each were made on September 1, 1911, and March 1 and September 1, 1912, and March 1, 1913. Since December 1, 1912, the bonds provide for cumulative interest at the rate of 5 per cent., and the present payment will make 2¼ per cent. paid in 1913.

**DETROIT, TOLEDO & IRONTON.**—The sale of the \$1,014,000 preferred stock of the Ann Arbor, which is deposited under the Detroit, Toledo & Ironton consolidated mortgage, has been adjourned to August 28.

**HAWKINSVILLE & FLORIDA SOUTHERN.**—This company, of which John B. Munson is president and general manager, on August 1 took over the operation of the line from Hawkinsville, Ga., southwesterly to Camilla, Ga., 97 miles, and including also the 14-mile line from Hawkinsville westward to Grovania, on the Georgia Southern & Florida. The lines here referred to are those which appear in the *Official Guide* under the name of the Gulf Line. The H. & F. S. proper extends from Hawkinsville to Worth, 42.5 miles. This has hitherto been operated by the Gulf Line. From Worth to Ashburn, 3 miles, the track of the Georgia Southern & Florida is used. All of the properties are owned in the interest of the Georgia Southern & Florida; and the G. S. & F., in turn, is controlled by the Southern Railway. Bonds to the amount of \$261,000 of the Hawkinsville & Florida Southern are to be issued in connection with the change, which appears to be virtually a consolidation of the H. & F. S. and the Gulf Line. Mr. Munson is vice-president and general manager of the G. S. & F. and also is Receiver of the Macon & Birmingham. The names of the officers of the new organization are given in another column. Most of these officers hold similar positions in the organization of the G. S. & F. or of the Macon & Birmingham.

**HOCKING VALLEY.**—The Ohio Public Service Commission has authorized the issue of \$1,000,000 5 per cent. equipment trust certificates. The certificates are to be secured by 1,000 50-ton coal cars, six Mikado locomotives and certain other equipment.

**ILLINOIS CENTRAL.**—Kuhn, Loeb & Company, New York, bought from the company \$3,500,000 5 per cent. equipment trust notes and resold them to Lee, Higginson & Company, Boston, and Kissel, Kinnicut & Company, New York, and these bankers are offering them to the public at a price to yield 5½ per cent. interest on the investment. The certificates represent 80 per cent. of the cost of the new equipment on which they are secured.

**NEW YORK, NEW HAVEN & HARTFORD.**—Control of the New England Investment & Securities Company has been sold by the New Haven to Sanderson & Porter, electrical engineers, 50 William street, New York. Control is vested in the \$100,000 common stock, which alone has voting power, and the \$4,000,000 preferred stock of the Investment company is held by the public, and 4 per cent. dividends are guaranteed on it by the New Haven, with a further guarantee of \$105 per share in the event of liquidation. The Investment company has \$15,000,000 notes outstanding, guaranteed principal and interest by the New Haven. The New England Investment & Securities Company controls the Worcester & Southbridge Street Railway, the Worcester & Blackstone Valley Street Railway, the Worcester Railways & Investment, the Springfield & Eastern Street Railway, the Milford, Attleboro & Woonsocket Street Railway, the Springfield Railways, the Springfield Street Railway, the Hartford & Worcester, and the Uxbridge & Blackstone Street Railway.

**NEW ORLEANS, TEXAS & MEXICO.**—The receivers of this subsidiary of the St. Louis & San Francisco have asked permission of the court to issue about \$1,000,000 receivers' certificates. It is estimated that about 18 months of work and between \$2,000,000 and \$3,000,000 will be required to put the N. O. T. & M. in thoroughly good physical condition.

# Railway Age Gazette

PUBLISHED EVERY FRIDAY AND DAILY EIGHT TIMES IN JUNE, BY THE  
SIMMONS-BOARDMAN PUBLISHING COMPANY,  
WOOLWORTH BUILDING, NEW YORK.

CHICAGO: Transportation Bldg. CLEVELAND: Citizens' Bldg.  
LONDON: Queen Anne's Chambers, Westminster.

E. A. SIMMONS, *President.*  
L. B. SHERMAN, *Vice-President.* HENRY LEE, *Sec'y & Treas.*  
The address of the company is the address of the officers.

**EDITORS.**

SAMUEL O. DUNN, *Editor.*

ROY V. WRIGHT, <i>Managing Editor.</i>	H. H. SIMMONS	E. S. FAUST
W. E. HOOPER	H. F. LANE	F. W. KRAEGER
B. B. ADAMS	E. A. AVERILL	A. D. CLOUD
E. T. HOWSON	R. E. THAYER	GEORGE L. FOWLER
	A. C. LOUDON	

Subscriptions, including 52 regular weekly issues and special daily editions published from time to time in New York, or in places other than New York, payable in advance and postage free:

United States and Mexico.....	\$5.00
Canada .....	6.00
Foreign Countries (excepting daily editions).....	8.00
Single Copies .....	15 cents each

Engineering and Maintenance of Way Edition and four Maintenance of Way Convention Daily issues, North America, \$1.00; foreign, \$2.00.

Entered at the Post Office at New York, N. Y., as mail matter of the second class.

WE GUARANTEE, that of this issue 10,150 copies were printed; that of those 10,150 copies, 8,674 were mailed to regular paid subscribers and 860 were provided for counter and news companies' sales; that the total copies printed this year to date were 285,909—an average of 8,664 copies a week.

VOLUME 55. AUGUST 15, 1913. NUMBER 7.

## CONTENTS

<b>EDITORIAL:</b>	
Editorial Notes .....	255
Rapid Increase in Steel Passenger Equipment.....	257
A Question for the Locomotive Engineer.....	257
The New Railway Managers and the Public.....	258
The Train Despatcher and the Block System.....	258
<b>LETTERS TO THE EDITOR:</b>	
Being Prepared When Safety Fails; by Jos. J. Morgan.....	259
Design of Concrete Ties; by K. R. Schuster.....	259
<b>MISCELLANEOUS:</b>	
*Reclaiming Scrap on the Santa Fe.....	260
*Trespassers Killed and Injured on the New York Central.....	267
Steel Passenger Train Equipment.....	269
Legislation Relating to Operation.....	270
Report on Butting Collision at Brant, Mo.....	270
Train of 99 Cars Hauled 111 Miles by One Locomotive.....	270
Are American Railroads Overcapitalized? by Alba B. Johnson.....	271
Traveling Engineers' Association.....	273
*Depreciation or Valuation of Properties; by L. R. Pomeroy.....	274
*New Pass Form for Rock Island Lines.....	275
Around the World in Thirty-Six Days.....	276
<b>MAINTENANCE OF WAY SECTION.</b>	
<b>EDITORIAL:</b>	
Editorial Notes .....	277
Cheaper Fuel for Pumping Engines.....	277
Reclaiming Maintenance Scrap.....	278
<b>MISCELLANEOUS:</b>	
*A Maintenance Department Testing Plant; by B. B. Milner.....	279
Abstract of Engineering Articles Since July 18.....	281
*New York Central Improvements at Rome; by Emile Low.....	282
*A Machine Car for Construction Work.....	285
Reinforced Concrete Telegraph Poles.....	286
*Methods of Handling Light Earthwork; by H. C. Landon.....	287
The Oil Engine in Railway Water Service; by C. R. Knowles.....	289
*Program of the Roadmasters' Association Convention.....	290
Specifications for Manganese Steel Rails.....	291
*Whitewashing Device with Portable Compressor; by F. W. Bentley, Jr.....	292
*Two Methods of Calculating Frog Angles; by F. W. Rizer.....	293
*Tests of a Fire Resisting Paint.....	293
*A Track Shifter.....	294
*The Kilbourne & Jacobs Automatic Air Dump Car.....	295
*University of Cincinnati Co-operative Course in Railway Engineering.....	296
Motor Car Troubles, Their Symptoms, Causes and Remedies.....	298
Handling Second-Hand Rails and Fastenings on Branch Lines; by P. H. Hamilton.....	299
Scale Shops .....	300
<b>GENERAL NEWS SECTION.....</b>	<b>301</b>

\*Illustrated.

ONE way in which the number of engine failures may be greatly reduced and the cost of locomotive maintenance cut down is to have complete data furnished to the mechanical engineer's office covering each defective part, whether it is cracked, broken or badly worn, and regardless of whether it caused an engine failure or was found while the engine was being cleaned or repaired. One man should be assigned to study and classify this data in order to determine just what steps should be taken to improve conditions. In some cases a radical change in design may be necessary, in others a slight change or rearrangement of the parts or apparatus may eliminate the trouble, while in still other cases it may be necessary to change the grade of material used for the purpose. Unless this is done it is quite possible on a road of average size for a given part to fail on several locomotives during a year and yet remain unnoticed because the failures may have taken place at different points, and in some cases may not have been noticed at headquarters because they did not result in engine failures. It is only by tabulating and classifying the various defects for the entire system and taking into consideration the number of locomotives on which each particular part is used, that conditions can be intelligently improved to reduce the number of failures with a minimum expenditure of the time and money to procure the best results. If records of this kind are kept and classified for a period of several years, it is possible to quickly and accurately determine just what parts can be attacked with the best results. If records of this kind are not kept, then the scrap pile offers the next best opportunity for securing information as to the failure of the various parts. This is particularly true where conditions make it necessary to ship all of the scrap which is to be sold, to one central part on the system. For instance, when the Santa Fe established the scrap plant at Corwith, Ill., those in charge noticed that as the scrap was sorted out certain parts which were used on equipment that had only been on the road for a few years, appeared in large numbers. Investigation showed that these parts had failed, due to defective design, and the purchasing agent was therefore in a position to ask the builders to furnish new parts of a better design at no expense to the railroad, thus preventing the continuance of failures and resulting in a considerable saving.

THE importance of inciting the magistrates and local authorities to make a more determined effort to reduce the trespassing evil on the railroads has been commented on many times in these columns. This seeming lack of interest may be due in some degree to the feeling on the part of the magistrates that they are dealing with a large floating class of tramps and hoboes, and that any effort on their part may not be of much avail unless concerted action is taken by the authorities throughout the country; in other words that a determined move on their part to punish offenders might result in an expense to the districts which they represent without effecting a very great improvement of conditions as a whole. The fallacy of this argument was clearly shown by F. V. Whiting, general claims attorney of the New York Central Lines, a year or so ago, when in analyzing the statistics for 1,000 persons who had been killed when trespassing, he found that practically 49 per cent. (489) resided near the place of accident, while the places of residence of 321 others were known, leaving only 19 per cent. in the hobo class, or whose places of residence could not be ascertained. These figures would seem to indicate that a disposition on the part of a magistrate to make an example of those who trespass on railroad property in his district, would, at least, have some effect on the 49 per cent. of trespassers who live in the immediate neighborhood. The New York Central has made attempts to get in touch with the magistrates along its line by furnishing them with literature on the trespass question. As far as can be seen this has not been productive of any



very important results, and it is planned to follow it up with a torney's staff. The safety exhibit car, described in last week's issue, contains an exhibit of special interest to magistrates and public authorities and an effort will be made to have them visit the car and examine it. Meanwhile, a more concerted action on the part of the railroads in dealing with this problem is promised by the appointment of a committee of the Association of Railway Claim Agents to deal generally with the trespass problem and co-operate with the General Managers' associations or the American Railway Association. While the enactment of proper legislation is necessary in some cases, experience has shown that the great difficulty is to secure a respect for the law already enacted by the punishment of the offenders; in other words, the problem is to educate the public to a state of mind where it is willing to have the law enforced. To secure the most effective results on any one road for the expenditure of a given amount of energy it might be well to concentrate on those points where the conditions are worst. In this connection the type of graphical chart used on the New York Central, which is shown on another page, is to be commended, for at a glance it may be seen just where the accidents are most frequent.

**D**URING his campaign for election as governor of New York William Sulzer promised the representatives of the railway labor brotherhoods that if he were elected and a full crew bill were passed he would sign it. Subsequent statements issued by Mr. Sulzer showed that he knew almost nothing about the causes of railway accidents in the United States or about the merits of full crew legislation. Nevertheless, after he became governor, in spite of the presentation to him of the most convincing arguments against train crew legislation, he kept his promise and signed a full crew bill. It is of no little significance that it is now this same Governor Sulzer of whom a legislative investigating committee reports, that he "made a false and fraudulent report to the secretary of state under his oath as required by law" as to the amount expended in his campaign for governor; "that he converted to his own private use contributions given in aid of his said election for the purchase of securities or other private uses; that he engaged in stock market speculations at a time when he was governor and vigorously pressing legislation against the New York Stock Exchange"; "that as governor he wilfully and corruptly made false public statements advising and directing citizens to suppress evidence in reference to his unlawful use of contributions made to him for campaign purposes"; and "that he has otherwise corruptly and unlawfully acted or omitted to act." As a result of the investigation and report of this committee the New York Assembly has adopted by a vote of 79 to 45 a resolution providing that Governor Sulzer "be and hereby is impeached for wilful and corrupt conduct in office and for high crimes and misdemeanors." It may be that the governor will disprove the grave charges made against him. But if he is guilty as alleged his conduct in reference to other matters has been perfectly consistent with his conduct in reference to the train crew legislation. It is alleged that he applied money that had been given to him for party purposes to personal uses. Now, in the case of the train crew matter, he used his position as governor of New York to put into effect a measure which injures the people of New York in order, evidently, to further his own political aggrandizement. This is not the first time that a public man who has professed himself an immaculate tribune of the people has promoted legislation for the benefit of certain classes of people at the expense of the whole people, and later fallen under suspicion regarding his personal probity. Only a few years ago Oklahoma had a governor who was a militantly strident self-avowed tribune of the people, and who waged remorseless, demagogic warfare on the railways. And subsequently, as an ex-governor, he was indicted for violations of

a federal statute. Thus it ever was. From the young man Absalom in Israel, and Alcibiades in Greece, to the present moment there never has been a demagogue who was worthy of public confidence; and the infallible mark of the demagogue always is that he makes unjust attacks on some particular class of the public, for the pretended good of the whole public. It is one of the things that are inexplicable that even in the most intelligent nations there always is a large number, and often a majority, of the people who will for a time, sometimes for a long time, accept the demagogue at his own valuation instead of at the valuation which his professions and his conduct stamp upon his brazen forehead in letters that are so unmistakable that it would seem that even a fool need not err therein.

**W**E publish elsewhere in this issue a summary of the legislation affecting railway operation passed by the 42 legislatures that had sessions in 1913. The summary is from a report that has just been issued by the Special Committee on Relations of Railway Operation to Legislation. It does not encourage the belief that the mania for regulating railways has subsided. In 1911, 512 bills to regulate railway operation were introduced in the 37 legislatures that met in that year. No record was kept of the number of them passed. In 1912 thirteen legislatures met in regular session, and there were introduced 272 bills for the regulation of railways, of which 48 were passed. In 1913 there were 1,395 bills for the regulation of railway operation introduced in the 42 legislatures that met, and of these 230 were passed. It will be noted that these figures include only measures relating to operation and exclude measures relating to rates, finances, valuation, and so on. Many of them were merely measures to amend laws already in effect, but in view of the hundreds of provisions affecting railways that have been passed within recent years it would seem that the time should have come for a reduction instead of an increase in the output of the legislative mills. The continued activity of the lawmakers is doubtless attributable to three principal causes. One is the desire to promote the public welfare by passing laws which are really needed. This doubtless is what led to the enactment of amendments to a good many laws already on the statute books. This also doubtless caused the passage of the six measures relating to trespassing on railways. The second cause of a good deal of legislation is the desire of many lawmakers, by introducing bills on which their names appear as the authors, to give their constituents the impression that they are really doing something. The third and main cause of legislation affecting operation, as the compilation plainly shows, is the ubiquitous activity of the lobbies of the railway brotherhoods. It is easy enough to trace to them the legislation regarding full crews, hours of service, service letters and time of payment, terms of employment, experience of employees, headlights, and so on. The result of the working of these causes in the state houses of 42 states has been the passage of some good measures and of a very large number of provisions that are restrictive, burdensome, meddlesome, inconsistent, expensive, unjust or downright silly. Most of the bills were introduced by members who knew little about the subjects with which they dealt and were passed by members who knew nothing at all about them. There is hardly a provision in the 230 measures adopted which does not tend to increase the cost of railway operation and thereby to either reduce the net earnings of the railways or to make it necessary for them to charge higher passenger and freight rates than they would otherwise have to charge. Fair and sensible regulation of railways is desirable, but to those who study the sort of regulation actually in vogue, especially in the various states, it sometimes seems that, on the whole, it is worse for the railways and the public than no regulation at all would be.

**RAPID INCREASE IN STEEL PASSENGER EQUIPMENT.**

THE wonderful increase in the number of all-steel passenger cars placed in service in the country since January 1, 1909, as indicated in the bulletin of the Special Committee on Relations of Railway Operation to Legislation which is reproduced, on another page of this issue, is all the more remarkable when we remember that the first modern experimental all-steel passenger car for use on steam roads was not placed in service until 1906. Prior to that time a number of designs had been developed for special purposes but not for regular through passenger traffic on steam roads. The introduction of the steel frame, side door suburban car on the Illinois Central in the fall of 1902 was probably the first move toward the introduction of steel passenger equipment in this country. Experience with a crude design of side door equipment in temporary use during the Chicago World's Fair demonstrated the value of this principle in handling suburban traffic and a steel frame was adopted for the superstructure because of its marked advantages for this type of construction. This design was followed shortly by a steel frame car designed by George Gibbs for use by the Interborough Rapid Transit Company of New York. It was desired to make it as nearly fireproof as possible, but a large amount of equipment was needed in a very short time and market conditions were such that it was impossible to obtain the desired amount of steel for an all-steel construction.

The Pennsylvania Railroad officers became interested in the development of an all-steel car at about that time because of the necessity of providing fireproof equipment for the tunnels under the North and East rivers, which were at that time in contemplation. President Cassatt therefore offered the assistance of the mechanical department of that road and a design for a sample steel car was developed and the car was completed at Altoona about 14 months after work on the design was started. This car was placed in service on the Second Avenue Elevated Line. The design was modified somewhat and in 1912 300 cars were built from the new design to be used in the New York subway. These cars contained only 680 lbs. of wood, all of which was fireproof, and in a second lot of cars which was built a short time later most of the wood was replaced by aluminum castings. Within the next year or two a number of steel passenger cars were designed and built, more particularly in connection with special service in the subway or with the electrification movement in and about New York. These included cars for the Long Island suburban traffic, the Philadelphia subway and the New York Central suburban traffic.

The first experimental cars for through passenger traffic on steam roads were built by the Pennsylvania Railroad at Altoona and the Southern Pacific at the Sacramento, Cal., shops. These were both built in 1906. It was not until the middle of 1907, however, that the first real move toward the introduction of the all-steel car for passenger service was made. At that time the Pennsylvania Railroad placed an order for 200 of these cars. The report of the Master Car Builders' committee on steel passenger cars at the June convention, 1908, showed that up to the time that the report was prepared, probably during the latter part of March or April, there were in service on the Interborough Rapid Transit and the Hudson & Manhattan, 390 all-steel cars; in suburban electrical service there were 135 all-steel cars on the Long Island and 125 on the New York Central & Hudson River; in steam railroad service there were 17 all-steel cars, including five passenger coaches, one sleeping car and 11 all-steel postal, baggage or express cars, the first all-steel baggage car having been placed in service by the Erie Railroad in June, 1904. There were also a large number of all-steel passenger equipment cars in process of building for the Pennsylvania Railroad, including 154 passenger coaches, 22 baggage cars, 10 dining cars, 14 postal cars and five passenger-baggage cars. The Long Island was also having built 50 suburban all-steel passenger cars. The wonderful progress which was made within the next few months is indicated by the fact that the report of the Special Com-

mittee on Relations of Railway Operation to Legislation shows that there were 629 all-steel passenger cars in service on the steam roads of this country on January 1, 1909, and that during the next four years to January 1, 1913, this number was increased to 6,642, or over 1,000 per cent. Another remarkable feature of the report is that on January 1, 1913, there were 1,649 passenger cars under construction, of which 85.2 per cent. were to be all-steel construction and only 3.3 per cent. of wood.

The development of these cars has been so rapid that in some respects they may be said to still be in an experimental state. Their behavior in rough service and wrecks has indicated their value from a safety standpoint, although there is still a considerable question as to the best type of design to properly dissipate the end shocks and afford the greatest protection to the passengers. With this in mind, several improvements have been made in the end construction, and the result of these will be watched with considerable interest and may lead to modifications in future designs. The prophecy of early designers to the effect that a time would come when steel passenger cars could be made as cheap as those of wood has come true, and while data is not yet available it is probable that the cost of maintenance of the steel passenger cars will be less.

The most troublesome problem in steel passenger car design at the present time is that of properly heating and ventilating the cars. It is necessary that the metal lining which is riveted to the framing and which is an advantage from the standpoint of strength, weight and cost, should be properly insulated so that heat may not be lost from the car by conduction during cold weather. That the railroads are to be commended for the rapidity with which steel passenger equipment has been introduced is indicated by the fact that five years ago, although there were only 17 all-steel passenger equipment cars in use, two-thirds of which were for postal, baggage or express service, today many of our roads use nothing but all-steel or steel underframe equipment on their high class passenger trains.

**A QUESTION FOR THE LOCOMOTIVE ENGINEER.**

THE locomotive runner should keep a perfect lookout. Every now and then the investigation of a collision or a derailment brings out the need of some system by which the runner can more surely keep an adequate lookout at every point throughout a run. A notable case was that on the Cincinnati, Hamilton & Dayton reported last January (*Railway Age Gazette*, page 92). To keep a vigilant eye on the track and signals throughout every foot of a run—as is highly desirable, if not absolutely necessary, and as would be done if, on a crooked road, at night, there were a possibility of finding a landslide every 50 rods—is, in the great majority of ordinary runs, a severe strain on the mind; for with long stretches where a few seconds' inattention does no harm, and with the varied distractions of duties connected with the boiler or the fire, or of necessary conference with the fireman, or of mere involuntary wandering of the mind, the most systematic mental discipline seems to be not entirely sufficient. How is the proper habit acquired? Every engineman desires, of course, to make a perfect record for safety; and every superintendent desires to have enginemen who can be depended on to carry out such a purpose in the most effective way.

Taking it for granted that some enginemen understand how to do this better than others, and that all desire to perfect themselves, we offer a prize of fifty dollars to the man who will write the best paper on the subject. The paper should be not over 1,500 words in length and should reach the office of the *Railway Age Gazette*, New York City, by October 15. Papers which do not take the prize, but which are used, will be paid for at our regular rates. Writers must tell the editor, briefly, what their experience has been; and preference may be given to those who have had most experience as engineers on fast trains. Also, narratives of actual experiences are desirable. To describe a mistake, or a narrow escape from one, may be the best means of safeguarding others against making the same kind of mistake; and should be useful

in illustrating the writer's recommendation as to how to avoid repeating it. In cases where a writer tells of his own mistakes, the matter can be published without giving the author's name. An engineer could send two papers, one to be published with his name and one without it.

#### THE NEW RAILWAY MANAGERS AND THE PUBLIC.

THE retirement of Mr. Mellen as president of the New York, New Haven & Hartford will mark an epoch in the history of railways in this country. Formerly the managers of railways regarded themselves as occupying positions substantially similar to those of the managers of other large concerns. They considered that it was their main, or almost their sole, function to earn profits for their employers. The law regarded railways as public servants. The managers recognized the theory, but to a large extent ignored it in practice. They submitted to the letter of legal provisions regarding rates and service, only in the measure that these were vigorously enforced by unusually energetic and aggressive public officials. But they often did not conform even to the letter of the statutes; and very commonly they violated the spirit of their function of public service.

During the last ten years, under the pressure of public regulation and public opinion, the attitude and conduct of railway managers have been undergoing a remarkable change. This has been due in no small measure to changes in the personnel of the managers. Some of the older leaders of transportation have demonstrated their statesmanlike qualities by adapting themselves to the changed conditions. Many of them, either in the ordinary course of events or owing to the development of conditions to which they could not adapt themselves, have been retired. There has, consequently, sprung up a new generation of managers—some of them new only in the adaptation of their policies to the spirit of the time, many of them, as managers, new in fact. The members of this new generation are animated not only by the desire to earn profits for their employers—a desire without having which in large measure they would be commercial eunuchs—but also by the desire to perform fully and loyally their function as servants of the public. They recognize the difficulties in the way of performance of their dual duty, but they accept unreservedly its responsibilities.

Mr. Mellen belonged to the last generation of the railway managers. Able and ambitious, he proved himself incapable of performing the functions of a public servant. Perhaps his deficiency was not so much lack of ability to do the work of a public servant well, as lack of ability to do it satisfactorily. At any rate, he showed such lack of capacity for adapting himself to contemporary conditions that it became evident to everybody else long before it did to him that his days as a railway manager were numbered. His retirement will mark the abdication of the last of the railway czars. It will be of no less significance in the country as a whole than in New England, for it will eliminate the last of the managers whose ability as executives was equaled by their ability to arouse antagonisms almost, if not quite, as inimical to the interests of the railways as downright inefficiency in operation. The changes that have been occurring in the personnel of railway managers, could not be more strikingly illustrated than by the differences between the characteristics and methods of Mr. Mellen and of those who are to succeed him in the management of the transportation system of New England. Mr. Elliott, Mr. Hustis and Mr. McDonald are typical of that fine race of American railway officers who unite to great executive ability a conception of public duties and a disposition to live up to it, which were almost unknown not many years ago.

It is a question of vital importance whether the public fully appreciates the changes that have been occurring in the personnel of railway managers and in their attitude toward the public. Unless the public does appreciate these changes it will not sufficiently modify the policy it has followed with reference

to railways during recent years. And if the public attitude and policy are not to be greatly changed there is serious trouble ahead for the railways and the country. To sum up the situation in a word: will the public call off the railway baiters for a while and give the new generation of railway managers a fair chance? There is no doubt that the sentiment of the public toward the railways has softened very much. Unfortunately, while the public is no longer urging forward attacks on railways it is not requiring them to be stopped. This is clearly shown by the statistics regarding the number of laws to regulate railway operation which have been passed by the state legislatures during the present year. Most of these laws are harmful to the railways and do the public no good. The public has compelled the railway managers largely to reform. When, if ever, is it going to compel the law makers and administrative public officials to reform? When is it going to recognize the fact that by permitting legislatures and railway commissions to impose numerous unnecessary restrictions and burdens on railway companies it is permitting them to make it impossible for the new generation of railway managers to live up to the modern conception of the function of the railway manager as a public servant?

The public is often strangely forgetful of the fact that it, as well as the individuals composing it, has duties and responsibilities. However, the situation does not afford ground for pessimism. Public officials always lag somewhat behind public opinion. The change in public opinion with reference to railways seems to be unmistakable; and, perhaps, in due time the conduct of the servants of the public will catch up with the views of the public.

#### THE TRAIN DESPATCHER AND THE BLOCK SYSTEM.

A PERSON who sits on two stools is in danger of falling to the ground. This has been illustrated many times in train management. A conspicuous example is found in the practice of many American railroads which use the manual block system on single track but which, for protection against butting collisions at meeting points, depend in part on the train despatcher. The rules do, indeed, provide for all possible conditions, and the weakness due to a division of responsibility is in most cases hard to locate and define; it is not often susceptible of proof. And yet the feeling that it exists is very definite. Station operators do not exercise the cautious vigilance that they would if they knew that everything depended on themselves and there were not a despatcher also on guard. Despatchers, no doubt, relax, knowing that the station-to-station blocking constitutes one more safeguard against collision. It is rare that an experienced despatcher will deliberately put undue dependence on a station operator, for the despatcher's mind exercises caution automatically. But cases do occur. What seems to be a case of this kind is reported by the Interstate Commerce Commission in the Brant collision, noticed in this issue.

This seems to be a case of the elusive fault which we have mentioned. We cannot say positively that it is, for the report does not elucidate the details with sufficient fulness to enable one to draw a conclusion. And this difficulty of getting governmental (or railroad) investigators to air the facts thoroughly in cases of this kind is one of the reasons why the adoption of the block system, in its completeness, is the only remedy for the collision disease that can be recommended unreservedly. It is conceivable that, with certain improvements in personnel, the arrangement of meeting points on single track could be made tolerably safe without incurring the expense of the block system; but as nobody who has the power will go into the subject deeply enough to warrant safe conclusions as to the character and extent and feasibility of the improvements needed or desired, the simpler remedy, the block system, is the only resource.

Not all of the circumstances of this case are clouded, how-

ever. The government investigator says that the despatcher disobeyed a rule, requiring him to send the order simultaneously to both trains. No rule of any railroad requires this. Simultaneous sending is required "if practicable." What the investigator means, no doubt, is that the order should have been written in the same words for both trains. Apparently the despatcher, to save a little time, transmitted to the westbound train, No. 11, only a part of the order which was sent to the eastbound, No. 12, omitting parts that did not affect No. 11. In doing this he, in effect, *made a new order*. This is not stated explicitly, but as both the long and the short order are spoken of as "Order No. 4," this is the only conclusion that can be reached. Evidently, there is needed a rule that in transmitting orders to opposing trains the despatcher shall read from the same paper, and *read the whole of the same paper*, for each of the two trains. Errors of despatchers are supposed to be checked by the repetition of orders by receiving operators. The present report is silent on this point; but the many difficulties which have been encountered in this matter in the past suggest that counting the words, as is done with paid messages, would often be a safeguard against errors like that which was made in this case.

Another safeguard which ought to be regularly employed is the practice of beginning a new paragraph for each movement in an order. This is a simple thing to do, and an effective safeguard; but few, if any, superintendents have had the persistency to enforce it uniformly. The difficulty of securing attention to a simple improvement in the despatching system is one of the reasons why the system as a whole has been condemned.

Neither is all of the station operator's negligence obscure. The report does not say so, but it is evident that the operator, when he gave a clear signal to the westbound train, omitted the simple, but imperative, routine procedure of looking at his train sheet. Passing over all consideration of this feature, the report goes on to say that automatic signals are safer than manual. This is true enough, as a general proposition; but the immediate question is not so general. The question is whether the operation of the manual system can be improved. During the one, two, five or ten years that must elapse before money can be found to install automatic signals it is the duty of the railroads to enforce the space interval system in the next best way, that is, by the manual block system.

Obviously, there is a question of discipline and training to be settled, as regards this operator, whatever may be the character of the block signaling rules. And in the matter of the concurrent neglect of the despatcher and the operator there is the harder question, alluded to in our opening paragraph, of insuring that neither shall relax his vigilance because of an unauthorized dependence on the other. To guard against this danger is not impossible, for experiments on the Erie and the Northern Pacific have demonstrated that in the ordinary practice there is much to be desired; but, as intimated above, the only generally accepted remedy for the weaknesses of the despatching system is the full adoption of the block system; and on single track this usually means automatics.

The Interstate Commerce Commission's report is incomplete in certain details, as we have pointed out. It is also incomplete in another feature; that wherein it says of the despatcher that "he was not in physical condition for the proper performance of his duties." What was the matter with him? This is a grave question. Many readers will read between the lines and conclude that he was under the influence of liquor. If such was the case the report should give the facts. If such was not the case justice to the despatcher demands that the facts be stated. And the station operator's record is clouded by a statement about the use of intoxicants. The report ought to say whether this cloud merits consideration at the present time. With railroad superintendents all over the country constantly wrestling with the difficulties of the liquor question, a policy of silence has nothing to commend it.

## Letters to the Editor.

### BEING PREPARED WHEN SAFETY FAILS.

KINGSTON, N. Y., July 28, 1913.

TO THE EDITOR OF THE RAILWAY AGE GAZETTE:

The efforts of safety committees on railways throughout the United States, and the results secured by them, deserve nothing but praise and commendation. In spite of all efforts to promote safety, however, accidents do sometimes occur and the provisions for alleviating suffering resulting from such accidents are in too many cases insufficient. Most railroad men have witnessed scenes of terrible suffering without having at hand any means of lending aid until a physician could arrive, which in many cases is too late to save life. Every railroad man cannot be a doctor, but if general instructions were issued as to first aid measures and certain employees provided with emergency sets, a great deal could be done toward alleviating pain and possibly saving life.

The first aid instructions could be printed in pamphlet form with heavy covers and should be of a convenient size to be carried in the coat pocket for reference at any time. The emergency sets should be complete enough and still simple enough to allow an employee with a set of instructions to perform any of the well known first aid measures that are often so important.

JOS. J. MORGAN.

### DESIGN OF CONCRETE TIES.

NEW YORK, May 9, 1913.

TO THE EDITOR OF THE RAILWAY AGE GAZETTE:

In the *Railway Age Gazette* of April 11, 1913, Paul M. La Bach, dwells on the question of reinforced concrete ties. His sketches and the technical part of his letter show that Mr. La Bach understands the matter thoroughly. I may, however, be permitted to add that the reason why concrete ties tested heretofore have failed, is the lack of what I believe to be the most important part of the reinforcement next to the longitudinal bars. So far as I know, this auxiliary reinforcement is not provided in any of the ties that have been tested thus far. This reinforcement consists of hoops or spirals which tie the concrete under the base of the rail together and reinforce it laterally and corresponds to the hoop or spiral reinforcement of columns which is well known in concrete building construction.

It has been shown by numerous tests of columns that the concrete under sufficient loading swells; that is to say, it expands laterally before it fails completely by crumbling. The mission of the hoops or spirals in columns is to prevent this swelling of the concrete, and it is a well known fact that columns thus reinforced have about twice the carrying capacity of columns reinforced longitudinally only. It seems to me that the same action must take place in cross-ties. The concrete under the rails is exposed to heavy pressure and pounding, and unless strongly reinforced there, it soon goes to pieces, owing to expansion and, finally, crumbling. Therefore, concrete ties should be substantially tied together by hoops or spirals. Photographs and reports on concrete ties that I have seen in various publications seem to prove the correctness of my deduction, inasmuch as they show that most ties have failed by longitudinal splitting or crumbling of the concrete under the rails, which would undoubtedly have been avoided by properly tying the concrete together. Concrete reinforced and tied together in all directions so that any possible tension or expansion stresses will be taken care of by steel, resists the most severe vibrations and shocks remarkably well. Concrete ties have fallen into bad reputation, because so many faulty designs have been tested and, of course, found wanting. K. R. SCHUSTER.

# RECLAIMING SCRAP ON THE SANTA FE.

Material Valued at Half a Million Dollars Reclaimed During 1912-13 at the Shops for This Purpose at Corwith.

Ten years ago the highest average price for No. 1 railroad wrought scrap during any one month was \$20.40 per net ton at Chicago. The highest last year was \$14.25. This ratio is substantially the same for other classes of scrap and the reduction has been gradual. A few years ago the railroads, beginning to feel this reduction began to watch the scrap pile more closely. It was found that considerable usable material could be reclaimed at a very small cost, and reclaiming shops or scrap docks have been established on many roads. The most extensive plant is that of the Atchison, Topeka & Santa Fe, located at Corwith, Ill, near Chicago. It was originally simply a collecting depot for the scrap on the Santa Fe system, the scrap being hauled to Chicago because there was practically no market west of that place. But as the possibilities of the amount of material that might be reclaimed have been realized, this scrap yard has been enlarged and buildings have been erected and machines installed until now it represents the most complete plant of its kind in this country; improvements and additions are still being made. The main shops of the reclaiming plant are shown in Fig. 1.

During the year 1912 there were 143,142 tons of scrap handled at Corwith, at a total cost (including all charges) of \$50,063.67. The scrap sales amounted to approximately \$1,000,000 and the value of the materials reclaimed from the scrap was \$421,497.48; this was handled or made serviceable for use at a cost of \$53,766.81, or at the rate of \$12.76 per \$100 reclaimed. This is truly a wonderful return on the money invested. The growth of the plant is indicated by comparing the above figures with those for 1911, when 140,018 tons of scrap were handled at a total cost of \$50,931.45, from which \$367,727.45 worth of material was reclaimed at a cost of \$10.03 per \$100. While it appears that the rate of cost of reclaiming was less in 1911 than in 1912, it will be seen that material of a greater value was obtained in 1912, which would indicate that more expert labor was required to do the reclaiming. Investigation showed that to be the case. The material reclaimed during the fiscal year ending June, 1913, amounted to approximately \$500,000.

Before going further it must be clearly understood that the material received at Corwith is absolutely scrap material, i. e., material that cannot be used without extensive repairs, and in anticipating the question concerning the disposition of the usable material it may be said that about \$50,000 worth of such material is reclaimed at the local shops throughout the system each month.

The following table will give an idea of the amount of material and the value of the more important items handled at Corwith:

SCRAP HANDLED DURING 1912.	
Miscellaneous scrap	75,000 tons
Rail	9,569 tons
Miscellaneous brass scrap	2,193 tons
Hose	193 tons
Hose fittings	11 tons
Rope	41 tons
Babbitt	156 tons

MATERIAL RECLAIMED DURING 1912.		
	Number.	Value, New.
Tie plates	9,907	\$1,519
Track spikes	1,110 kegs	3,996
Nuts	283,650 lbs.	6,750
No. 2 track shovels	3,587	1,937
Scoops	600	222
Tamping picks	9,307	5,025
Brake beams	6,293	17,254
Track jacks	807	4,000
Norton jacks	324	4,652
Track drills	317	5,397
Wheelbarrows	75	203
Switch stands		5,400
Angle cocks	610	
Miscellaneous valves (¼ in. to 4 in.)	5,626	

## MATERIAL RECLAIMED DURING 1912 (Continued).

	Number.
Miscellaneous bolts	2,307,354
Warehouse trucks	389
Couplers (to be filled in by oxy-acetylene process)	1,000
Steel wheels (re-tiring)	4,500
Round and flat iron	20,000 tons to be re-rolled

Another important feature of the reclaiming at Corwith is the replacement of defective material. All the material is carefully inspected before it is sold as scrap, and a good deal of it is found to have builders' defects. An example of this is shown in the illustration of the cylinders, Fig. 2; the group in the foreground has been picked out from the rest waiting for inspection by the builder and will be replaced. Couplers, bolsters, and other material have also been found with such defects and have been replaced by the builders.

## COLLECTION AND CREDITS.

The scrap is shipped to Corwith from all over the system as fast as it accumulates in carload lots; the scrap along the line is picked up each month by the supply trains. There is no sorting done outside of Corwith, except when the scrap is being loaded at terminal points where workmen from the mechanical department assist the store department in loading so that they may retain any serviceable material that has found its way to the scrap pile. There is, however, a further exception with regard to the rail. All rail except that from southern Kansas and Illinois, is sent to Newton, Kan., where it is sorted, the usable rail being held for re-rolling or drilling at that place, and the scrap sent to Corwith for sale. In southern Kansas and Illinois the usable rail is sent to Newton and the scrap direct to Corwith to prevent back hauls.

About 95 per cent. of the scrap which comes into Corwith from off the line is loaded in foreign coal cars which were originally loaded west to Texas, New Mexico, Arizona and California with oil well casing, pipe, supplies, etc. These cars, were it not for the scrap coming to Corwith, would probably have to be hauled back empty. These same cars are used to load the scrap when it is ready to sell, so that it can be readily seen that only 5 per cent. of the scrap is handled in Santa Fe cars.

As the miscellaneous scrap is taken from each division, that division is credited with a fixed scrap price of \$10.31, and later if the scrap is sold at a different price that division is again credited or debited, as the case may be, with the difference. The total scrap credit, however, that is given to each division and balanced against the operating expenses consists of the above, plus the value of the defective material replaced by manufacturers, plus the difference between the market price of the reclaimed material and the cost of reclamation, together with the scrap value of the reclaimed material. This scrap credit is then proportioned to the various operating accounts as follows:

	Per Cent.
Track fastenings	5
Bridges	0.5
Signal department	0.5
Telegraph department	0.5
Buildings	1.5
Track tools	0.5
Engine repairs	28
Passenger cars	7
Freight cars	52
Work cars	2
Shop machines and tools	1.5
Train supplies	0.5
	100

These proportions were determined from the operating costs of a period extending over three years. This allotment of scrap credit is carried still further to each individual unit, such as each locomotive, by distributing the pro-rated amount given to that individual account to each individual unit represented in the

account in the same proportion as the cost of repairs on that unit bears to the total amount spent on that account. In this way the operating accounts are directly benefited by the value of the scrap obtained from repairs, as they should be.

SCRAP YARDS AND HANDLING OF SCRAP.

Corwith, Ill., where the scrap dock is located is on the main line of the Santa Fe, about 6 miles south of Chicago. It covers

an area of about 25 acres, and is equipped with the following reclaiming shops:

Wheel and rolling mill shop.....	40 ft. x 274 ft.
Bolt and blacksmith shop.....	40 ft. x 290 ft.
Storehouse .....	28 ft. x 276 ft.
Hose house .....	28 ft. x 80 ft.
Brass house .....	40 ft. x 100 ft.
Valve and spring shop.....	24 ft. x 180 ft.

These buildings were made largely from scrap lumber obtained from all over the system and were put up by the work-



Fig. 1—Main Shops for Reclaiming Scrap at Corwith, Ill.; Atchison, Topeka & Santa Fe.

men at the plant. There are about 375 men employed, most of whom are unskilled laborers. There are, however, a few skilled mechanics for special work, such as repairing triple

ding of scrap, and cost to operate only five cents per ton of scrap handled. As they are constantly required for unloading and loading the cars, they switch the cars to the loading and



Fig. 2—Scrapped Cylinders; Those in the Foreground Are Held for Inspection by the Bullder.

valves, mounting car wheels, turning tires, etc. Four locomotive cranes are used throughout the yards, three of which

unloading points instead of requiring the services of a separate switch engine.

The carloads of scrap received at Corwith are first weighed and then placed on the receiving track, which is the middle track shown in Fig. 3. From the cars it is sorted into its various classes by a gang of about 80 men, iron baskets being placed on both sides of the track for the different material.

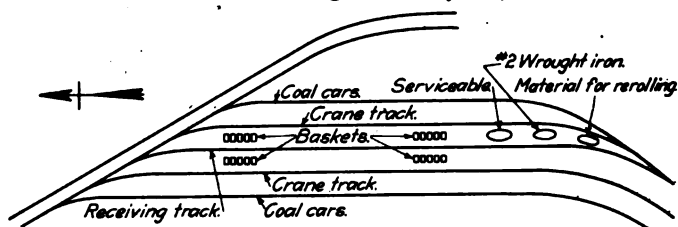

Fig. 3—Arrangement of Tracks for Sorting Scrap at Corwith; A., T. & S. F.

are equipped with lifting magnets, and the fourth with a clam shell bucket. These cranes are an important item in the han-



Fig. 5—Assorted Scrap Material Awaiting Inspection and Repairs.



The pile just to the right of the flat car is usable material. Fig. 4—Method of Sorting Scrap from the Cars.

The tracks on both sides of the receiving track are used for the cranes and flat cars on which are loaded the baskets containing the scrap that is to be held for future sale. The scrap ready for immediate sale is dumped directly into coal cars on the outside tracks and is shipped to market as soon as a carload has accumulated. The full baskets on the flat cars are shifted to the various classified piles awaiting sale, or to the shop for

reworking. The different classes of scrap into which all the mixed scrap is divided as it is taken from the cars are as follows:

Burnt cast iron.	No. 1 wrought iron.	Spring steel.
Black cast iron.	Brake shoes.	Springs that are good.
Long pipe.	Axle butts.	Knuckles (good).
Short pipe.	Malleable iron.	Knuckles (bad).
Soft steel.	No. 1 sheet iron.	Drawbars (good).
Tool steel.	No. 2 sheet iron.	Drawbars (bad).
Bolts.	No. 2 wrought iron.	Borings.

Many of these are classified still further prior to sale. The brass scrap is shipped to Corwith in locked box cars, but that

material taken from the scrap. The couplers and bolsters shown in Fig. 5 are to be examined for cracks and breaks, and those that cannot be repaired by being filled in by the oxy-acetylene process will be scrapped. The springs are taken to the spring shop and tested, and if found fit for service are retempered; if not, they are uncoiled and made into jimmy bars, claw bars, etc. The brake beams are carefully inspected and those needing repairs are sent to the smith shop where a force of 12 or 15 men is constantly employed in putting in new struts and brake heads. The driving tires shown at the right in Fig. 4 are also inspected and those found serviceable for light power in switching service are made use of. As many as 170 have been reclaimed in one month.

A pile of spikes that have been reclaimed from the No. 2 wrought iron scrap and several barrels of nuts are shown in

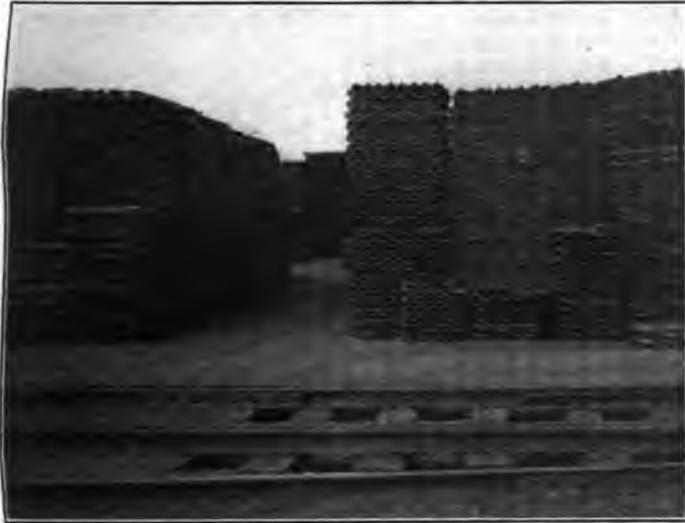

Fig. 6—Rail Angle Bars Obtained from the Scrap Pile.

which accidentally finds its way to the miscellaneous scrap is sorted and placed in separate piles, being collected frequently by means of a wheelbarrow. Any material having brass attached to it is placed in a separate pile and the brass is removed. The serviceable material, the No. 2 wrought iron and the material to be re-rolled, is thrown to one side and piled as indicated in Fig. 3. All the shovels and track forks with



Fig. 8—Track Spikes and Barrels of Nuts to Be Reclaimed.

Fig. 8. The spikes are first rattled and cleaned of rust, and then straightened and sharpened under a small belt hammer. Nuts were retapped at a net saving, during the month of May, of \$616.80 for 162 kegs.

A pile of usable material and long iron for re-rolling as it is sorted out from the scrap cars is shown in Fig. 9. A pile of scrapped rail ready to be sold is shown in Fig. 10.

As stated in the first part of the article the reclaiming plant has grown rapidly in the past two years, and it is only now that



Fig. 7—Steel Wheel Centers Held for Re-tiring.

broken handles are placed in another pile and the old handles are burned off. As it is impossible to have a bucket for each material within throwing range of each car, piles are made in the cars themselves, as shown in Fig. 4, at the right, the cars later being switched to the various piles and unloaded by a locomotive crane. The iron baskets used for collecting the scrap are cut from the scrapped fireboxes by the oxy-acetylene process. Figs. 5, 6, 7, 8 and 9 show various groups of the ma-



Fig. 9—Usable Material and Rods for Re-rolling Found in the Scrap Pile.



it is able to handle the scrap as it is received. It was therefore necessary to store the scrap in a heterogeneous heap, as shown in Fig. 11. These heaps are, however, being rapidly cleared up in the manner shown in the picture.

#### RECLAIMING PLANT.

The equipment of the shops for reclaiming the material is most complete. A very few new machines were purchased for these shops until recently, when it was found necessary to furnish better machines in order to do the class of work required. The re-



Fig. 10—Scrapped Rail Ready for the Market.

rolling shop is equipped with a large Williams, White & Company shear, shown in Fig. 12, which will shear a  $1\frac{1}{2}$  in. plate, 60 in. wide, or a  $1\frac{1}{4}$  in. plate, 100 in. wide. This machine is used for cutting the heavy rods and flat iron. The rolling mills are shown in Fig. 13; the one in the foreground is used for rolling  $3\frac{1}{2}$  in. stock to 2 in., and is operated by a 100 h. p. motor. The second mill is used for rolling 2 in. stock down to  $\frac{1}{2}$  in. and is operated by a 50 h. p. motor. During the month of May 125 tons of material was re-rolled by the small rolls, the other rolls not having been installed, with a net saving in the cost of material of \$1,514.34, or a saving of \$12.12 per ton. With the new mill in service, and as the workmen become more accustomed to the

work, a greater saving will be made, and three or four times as much tonnage can be handled. The rods are heated for rolling in the soft coal furnaces at the left of the rolls.

The rods from the rolling mills are cut to length in a No. 6 and No. 8 Whiting double shear and formed into bolts on two  $1\frac{1}{2}$  in. Acme, one 2 in. Ajax and one 3 in. Acme bolt heading machines. They are then threaded on six 3-headed Acme and two 3-headed Landis bolt threading machines. While all of this equipment was

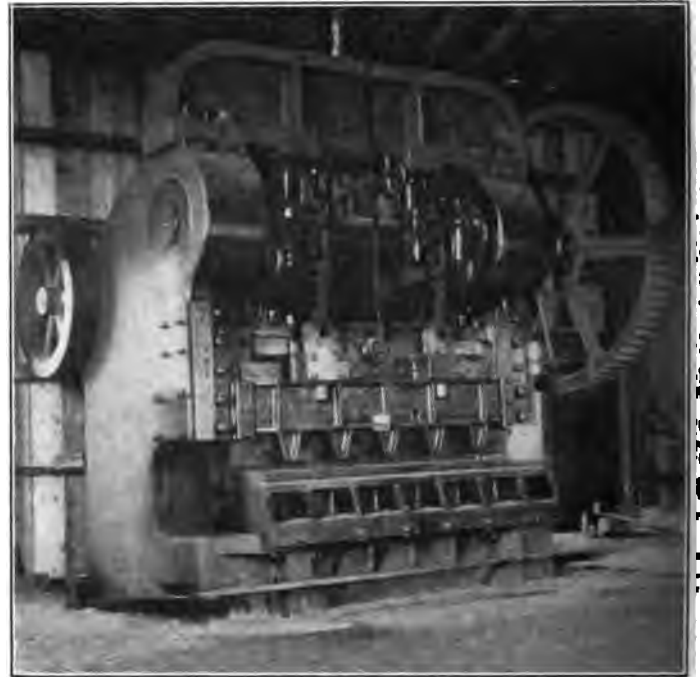

Fig. 12—Large Shears for Cutting Heavy Rods and Bars for Re-rolling.

not in service last May, there were 333,790 bolts made during that month at a net saving of \$4,102.15. Fig. 14 shows the south section of the bolt shop. An extension has been built on the left for additional machines.

A very material saving is also made in re-tiring the steel wheels that are standard on the Santa Fe lines. These wheels were previously sent to the Standard Steel Works Company at Burnham, Pa., for re-tiring at a freight charge of \$6 a wheel;



Fig. 11—Sorting the Scrap from the Accumulated Piles.

they are now re-tired at Corwith at a net saving of \$1,619.47 for 361 wheels in addition to the saving in freight charges. The equipment for handling this work consists of four boring mills, three of which are shown in Fig. 15, one wheel lathe, one axle lathe, a 400-ton Niles-Bement-Pond wheel press, a turret lathe, two radial drills and one vertical drill. There is also an oil fire for shrinking on the tires.

As the re-tiring of all steel tired wheels is done at Corwith (except the driving wheels), it is made the distributing point for

find their way into the scrap pile, but owing to the above-mentioned reports, the wheels are forwarded to another division where lighter power is used and they are worn to their scrap limit.

The smith shop is provided with 15 forge fires, three small belt hammers, and a test rack for brake beams. This shop is called upon to do various jobs, the most important being the repairing of brake beams, the good parts of one being used to repair another, new heads and struts being applied where neces-

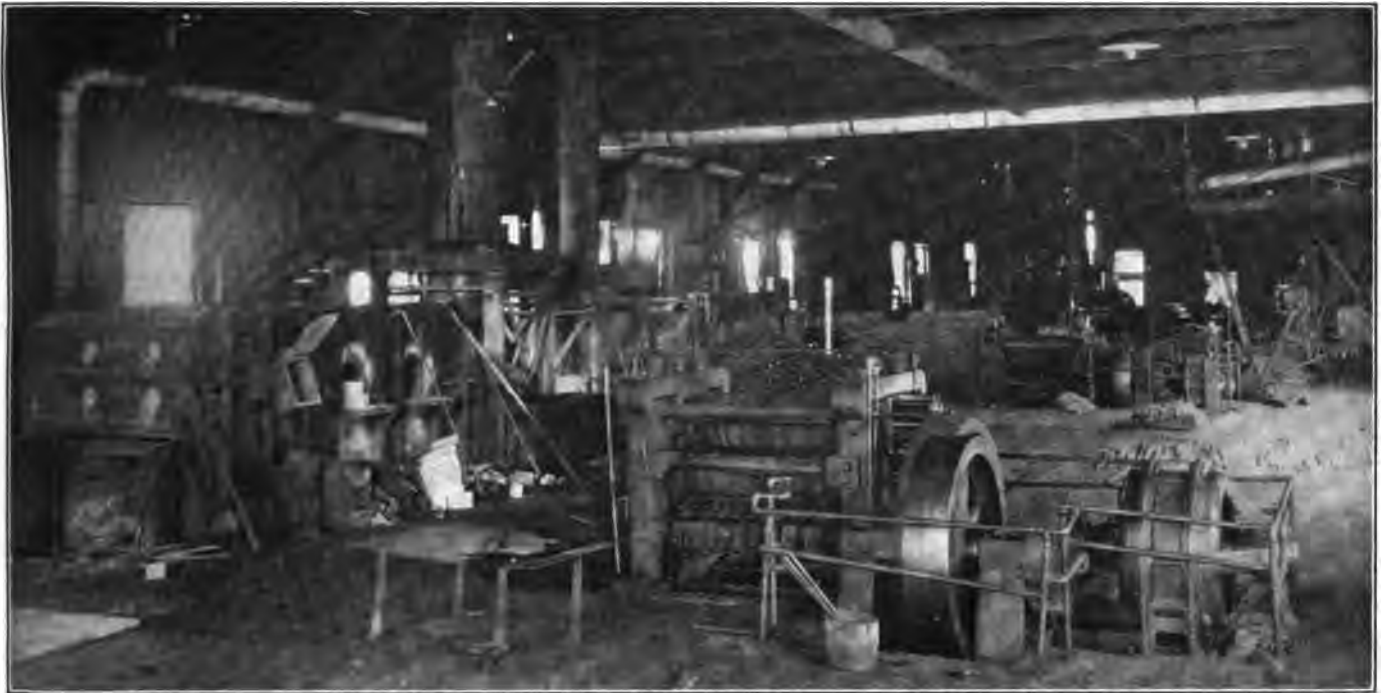

Fig. 13—Rolling Mills for Reclaiming Bar Iron.

this class of wheels for the whole system. A complete system of monthly reports, signed by the mechanical and store department officials, showing wheels on hand and their condition so far as wear on tires, flanges, etc., is concerned, enables the foreman in charge at Corwith to handle the distribution to the best possible advantage; for instance, one division point may have wheels on hand with tires too thin for the class of locomotives running out of that point. Under ordinary conditions these wheels would

sary. During the month of May 166 beams were thus reclaimed, with a net saving of \$257.09.

Other work done in the smith shop is the repairing of the material shown in the following table, in which is included the net saving made on that work during the month of May:

Material.	Number of Pieces.	Net Saving.
Picks .....	61	\$15.68
Track drills .....	45	666.01



Fig. 14—South End of the Bolt Shop In the Reclaiming Plant.

Material.	Number of Pieces.	Net Saving.
Jacks .....	170	903.83
Claw bars .....	95	79.71
Tamping picks .....	1,722	467.05
Switch stands .....	105	590.12
Jimmy bars .....	151	50.06
Knuckle locks .....	304	176.42
Switch chains .....	34	112.20

It will be noted that there is a considerable saving in the track drills, jacks and switch stands. These are mainly repaired by taking the good parts of one to replace the broken parts of another,

the repairing of trucks, shovels and ballast forks. Two men are constantly busy on this work, and while the repairs are not extensive, considerable material is reclaimed, old handles taken from the broken blades being put in the shovels and forks. During last May 349 shovels were reclaimed at a net saving of \$127.27; 43 ballast forks at \$46.51, and a few trucks at \$52.84. The latter item does not show as great a percentage of saving as the average.

The north end of the building is given over to the hose shop,



Fig. 15—Boring Mills in the Wheel Shop.



Fig. 16—Interior of the Storehouse for Reclaimed Material.

other, which together with what straightening and forging there is to be done provides good serviceable switch stands.

The spikes are also straightened in the smith shop under a belt hammer whose anvil has one corner beveled off for sharpening the spike. This operation is performed after the spikes have been rattled. During the month of May 131 kegs were thus reclaimed at a net saving of \$174.62.

The next building is the store house, a section of which is shown in Fig. 16. There is a room set aside in this building for

where all couplings, nipples, clamps, etc., are removed from the scrapped hose, and the good ones are cleaned, painted and put into service again. In this way \$259.89 was saved on air hose fittings and \$408.46 on steam hose fittings in one month. This work is done at Corwith for the whole system by three men; formerly it was done at the division points. The cost of labor for the work has thus been materially decreased, and during the past two years it has not been necessary to purchase any nipples or couplings.



Fig. 17—Reclaiming Babbitt from Old Car Brasscs at Corwith

The brass shop is located to the east of the above-mentioned shops, and is used for melting the babbitt from car brasses, as shown in Fig. 17, and for the storage of the brass scrap and babbitt pigs. It is provided with a Dings electro-magnetic chip separator for separating the iron from the brass chips, a scale for weighing the amount of the brass and babbitt handled, four babbitt pots and a furnace for melting the babbitt from the journal brasses. The magnetic separator has been found very profitable. The babbitt pots are made from old locomotive domes and are fired with coal. Every piece of scrap iron containing brass finds its way to the brass house, where it is removed. The babbitt is melted from the car brasses at a cost of 36 cents per ton.

The shop adjoining the brass house is a valve shop where such valves as are not too badly worn or damaged are repaired. This includes triple and retaining valves, as well as the ordinary gate and globe valves. The shop is equipped with bench vices, an emery wheel, 18 in. lathe, a small horizontal miller, a 9-spindle valve grinding machine, a Westinghouse triple valve test rack, a 26 in. shaper, a Lucas horizontal boring mill, a small planer and a 12 in. lathe. The last four machines are used for other work than repairing the valves, the chief work of the shaper being broaching out car brasses that have not been sufficiently worn to require re-babbiting. When there is plenty of work this shop will repair on an average of five triple valves, 25 to 30 angle valves, and 30 to 40 other kinds of valves per day. The chief trouble with the globe and gate valves is broken stems.

The following list shows the material reclaimed in this shop during the month of May:

Kind of Valve.	Number.	Net Saving.
Globe .....	430	\$46.72
Gate .....	44	57.16
Angle cocks .....	336	255.80
Cut-out cocks .....	191	79.45
Retaining .....	139	81.64
Triple (Westinghouse) .....	63	565.91
Triple (New York) .....	3	23.78
Broaching brasses .....	..	509.86
Boring brasses .....	..	225.54

The spring shop is just south of the valve shop and contains an air operated press to test the resiliency of the springs, a soft coal heating furnace, and an oil tempering bath. If the springs are found suitable for further use they are retempered; otherwise they are heated to a red heat and uncoiled, and are then sent to the smith shop to be made into claw bars, jimmy bars, etc. Springs valued at \$449.23 were reclaimed in one month with a net saving of \$195.92. This building also contains three rattlers and the boilers for heating the shops.

Of the castings reclaimed the small ones are cleaned in the rattler and the larger ones are dipped in paint. During last May the net saving from this one item was \$3,242.83.

The work at Corwith is greatly hampered by labor conditions and the difficulty in holding men. All kinds of nationalities are represented there. The more intelligent of these are taught to sort scrap while the others are kept at the wheel barrow. Regardless of these conditions, however, the plant is well organized and with a few steady men retained as foremen the work is carried on successfully and is giving remarkable returns.

We are greatly indebted for the information regarding the handling of scrap on the Santa Fe to M. J. Collins, general purchasing agent, under whose personal direction the scrap plant has become such a paying investment; to N. M. Rice, general storekeeper, who is directly in charge of the accounts at Corwith, and to R. K. Graham, general foreman at Corwith, and his associates.

**EARLY RAPID TRANSIT.**—The Camden & Amboy Railroad is, we learn, partly completed and in use. This road will probably be the most traveled in this country. Passengers who leave Philadelphia at half-past six in the morning may dine in New York at 4 p. m., as they are landed at half-past three o'clock. The time is not far distant when six hours will be ample time to perform the journey.—From the *American Railroad Journal*, October 6, 1832.

## TRESPASSERS KILLED AND INJURED ON THE NEW YORK CENTRAL.

To show graphically just how extensive are the injuries to trespassers on the New York Central & Hudson River, Frank V. Whiting, general claims attorney of the New York Central Lines, has had a graphical chart made as shown in the illustration. This diagram covers the calendar year 1912. On the original chart a circular tab or sticker, red in color, is used for each trespasser who has been injured, and a red "K" is pasted on the diagram for each trespasser that is killed. These are placed on the chart as soon as the accident is reported to the general claims attorney's office, and the diagram is therefore always up to date. The advantage of a chart of this kind is evident; at almost a glance it can be seen just where the accidents most frequently occur, so that special efforts may be made to improve conditions at those points.

The New York Central has given considerable effort to the prevention of accidents to trespassers, but the result has fallen far short of expectations because of the lack of co-operation on the part of the local authorities in the cities and towns along the road. In an article on "Trespassers Killed on Railways—Who Are They?" which was published in the *Railway Age Gazette* of March 8, 1912, Mr. Whiting showed conclusively that the problem is not so much one dealing with the tramp or hobo, but rather with those who in many instances are regularly employed, well-to-do and respected citizens, and that as far as prevention of accidents to trespassers is concerned the problem is really a local one, and wholly within the hands of the local officials.

That the magistrates have not co-operated with the railroad to as great an extent as is desirable is shown from the following data concerning the number of arrests during 1912 and the disposition of the cases:

CAR RIDING.			
Penitentiary .....	472	Suspended sentence .....	2,976
Jail .....	1,072	Discharged .....	624
Reformatory .....	11	Turned over to outside police. ....	4
Humane Society .....	46		
Fined .....	201	Total .....	5,422
Probation .....	16		
TRESPASSING.			
Penitentiary .....	70	Suspended sentence .....	585
Jail .....	146	Discharged .....	97
Reformatory .....	3	Probation .....	24
Fined .....	32		
Humane Society .....	8	Total .....	965
		Car riding.	Trespassing.
Total number of days in sentences (penitentiary)....		18,453	3,118
Total number of days in sentences (jail).....		11,420	880
Total amount of fines paid.....		\$966.00	\$142.00

From the above it will be seen that less than 30 per cent. of the trespassers were punished for car riding, and only about 26 per cent. for trespassing. In about 67 per cent. of the cases the offenders were discharged or given a suspended sentence because the local communities did not care to incur the expense of sending the men to the jail or reformatory. When it is considered that the railroads are among the largest taxpayers in the communities through which they run, this hardly seems to be just. However thorough the railroad may be in policing its property there will be very little possibility of greatly reducing the evils of trespassing if the matter continues to be handled in this way.

The New York Central has tried to impress the local authorities with the necessity of dealing more severely with trespassers by sending to them Mr. Whiting's article on trespassing and similar information. This apparently has not been productive of results, and it is planned to have a member of the general claims attorney's staff visit the magistrates personally and try to impress upon them the necessity of greater co-operation. Meanwhile arrests of trespassers are being made at the rate of from 700 to 800 per month.

A determined crusade is being made to stop free riding on trains and to apprehend and punish car thieves. On the night

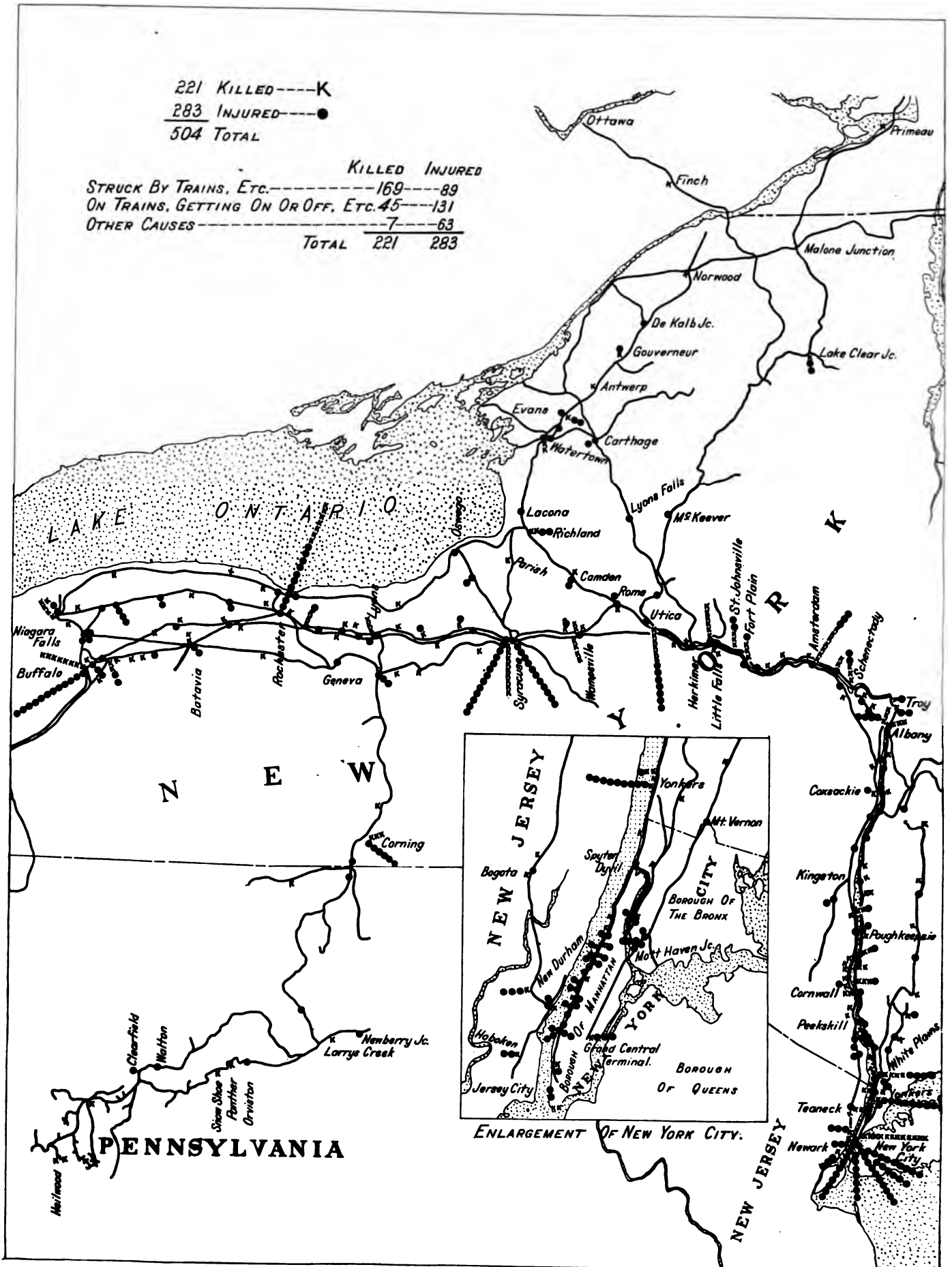

Showing Location of Accidents to Trespassers on the New York Central & Hudson River.

of July 29 practically all trains, passenger and freight, were stopped at S.S. 9, just west of Schenectady and a force of officers rounded up 46 men and had them sentenced as follows:

- 16 to penitentiary for 60 days each.
- 10 to jail for 30 days each.
- 7 to jail for 20 days each.
- 2 to jail for 15 days each.
- 3 to jail for 10 days each.
- 2 fined \$5.00 each, which was paid.
- 4 fined \$3.00 each, which was paid.
- 2 sentence suspended.

It is planned to repeat this treatment at other locations on the line.

A little over a year ago signs were placed on the telegraph poles warning trespassers, and reproducing part of the New York state law referring to that offence. While some of the local officers reported that these signs were being read and heeded, statistics for last year do not show that they effected any appreciable or permanent improvement. Believing that it would be wiser to post a briefer warning, measures are being taken to have the words "Do not walk upon the track" stenciled on telegraph and signal posts and other places where it will be seen and be liable to do the most good.

### STEEL PASSENGER TRAIN EQUIPMENT.

The Special Committee on Relations of Railway Operation to Legislation has issued a bulletin on steel and steel underframe passenger equipment, from which the following is taken:

Four bills are pending in Congress requiring the replacement of wooden passenger equipment in steel. The periods suggested during which this is to be done vary from January 1, 1915, to January 1, 1918.

In order to ascertain the progress of the building of steel and steel underframe passenger equipment, and to develop the cost of reconstruction in steel of the present wooden passenger equipment in the country, Circular No. 40 was issued to the railways on January 10, 1913.

Replies to that circular have been received from 247 companies, operating 227,754 miles in the United States, and 57,493 passenger equipment vehicles, with 1,649 under construction on January 1, 1913.

Replies have also been received from eleven companies, operating 24,718 miles in Canada, and 4,891 passenger equipment vehicles, with 517 under construction on the same date.

Tabulations based on these replies are shown in the large table.

The estimates and percentages given hereafter apply only to the equipment operated by roads in the United States.

Attention is called to the following:

	ACQUIRED.	Total Number.	Percentages		
			Steel Per Cent.	Steel Underframe Per Cent.	Wood Per Cent.
1909		1,880	26.0	22.6	51.4
1910		3,638	55.4	14.8	29.8
1911		3,756	59.0	20.3	20.7
1912		2,660	68.7	20.9	10.4
January, 1913 (under construction)		1,649	85.2	11.5	3.3

Between January 1, 1913, and July 1, 1913, orders have been placed by railways for 1,140 passenger equipment vehicles. Of these 1,064, or 93.3 per cent., are of all-steel construction, and 76, or 6.7 per cent., have steel underframes.

It will, therefore, be noted that the construction of wooden passenger equipment has practically ceased.

	APPROXIMATELY IN SERVICE.	
	Steel.	Steel underframe.
January 1, 1909	629	673
January 1, 1910	1,117	1,098
January 1, 1911	3,133	1,636
January 1, 1912	5,347	2,399
January 1, 1913	7,271	3,296
Increase 1913 over 1909	6,642	2,623
Increase 1913 over 1909	1,055 per cent.	389 per cent.

	APPROXIMATE COST OF REPLACEMENT.		
	Number.	Average Cost.	Amount.
Postal	580	\$11,000	\$7,480,000
Mail and baggage	2,724	10,000	27,240,000
Mail, baggage and passenger	679	10,000	6,790,000
Baggage and passenger	3,757	10,000	37,570,000
Baggage or express	7,431	8,500	63,163,500
Passenger	23,692	12,800	303,257,600
Parlor, sleeping, dining	6,864	22,000	151,008,000
Business	774	15,000	11,610,000
Motor	325	20,000	6,500,000
Total	46,926		\$614,619,100
Annual interest charge at 5 per cent.			\$30,730,955

The charge to operating expenses under the classification of accounts of the Interstate Commerce Commission, assuming a value of \$4,000 per vehicle replaced, will be \$187,704,000.

TABULATION OF REPLIES FROM 248 RAILWAYS, SHOWING ACQUISITIONS OF STEEL PASSENGER EQUIPMENT.

Number of Passenger Equipment Cars Operated	In Service December 31, 1912			Under Construction or Contracted for but not yet Received on Dec. 31, 1912			Acquired in Calendar Year 1912			Acquired in Calendar Year 1911			Acquired in Calendar Year 1910			Acquired in Calendar Year 1909										
	Number Roads	Steel	Steel Underframe	Wood	Steel	Steel Underframe	Wood	Steel	Steel Underframe	Wood	Steel	Steel Underframe	Wood	Steel	Steel Underframe	Wood	Steel	Steel Underframe	Wood							
1 to 50	147	33	160	1,905	14	6	19	13	2	49	12	19	58	22	10	57	9	15	73							
51 to 100	23	103	136	1,203	16	18	6	5	28	1	28	32	9	80	22	44	7	7	7							
101 to 200	21	107	190	2,337	14	1	1	42	98	30	43	63	23	78	2	46	59	62	34							
201 to 500	23	391	390	6,259	281	6	1	103	43	17	233	113	43	174	102	118	15	35	119							
501 and upward	33	6,644	2,430	35,222	1,080	159	28	1,666	384	179	1,896	536	646	1,662	383	818	405	308	734							
<b>Total U. S.</b>	<b>247</b>	<b>7,271</b>	<b>3,296</b>	<b>46,926</b>	<b>57,493</b>	<b>1,405</b>	<b>190</b>	<b>54</b>	<b>1,649</b>	<b>1,829</b>	<b>555</b>	<b>276</b>	<b>2,660</b>	<b>2,214</b>	<b>763</b>	<b>779</b>	<b>3,756</b>	<b>2,016</b>	<b>538</b>	<b>1,084</b>	<b>3,638</b>	<b>488</b>	<b>425</b>	<b>967</b>	<b>1,880</b>	
<b>SECTIONS:</b>																										
New England	9	32	121	5,468	115	8	20	16	22	103	14	422	24	193	10	6	114	10	6	114						
East	78	3,153	1,060	16,021	390	72	13	952	323	22	839	204	99	583	82	230	167	58	182							
Southeast	54	75	592	4,901	135	81	16	27	87	17	37	219	68	6	27	102	157	77	77							
Northeast	30	315	51	3,643	98	2	4	85	26	68	141	99	75	1	348	12	150	150								
Southwest	35	328	265	3,263	72	5	4	109	53	56	78	28	61	90	41	88	24	80	68							
West	40	2,039	1,032	8,982	318	22	1	357	33	10	550	208	30	743	363	68	269	174	109							
Sleeping Car Co's	1	1,329	185	4,648	276			283	12		519			519		54	6		268							
<b>Total U. S.</b>	<b>247</b>	<b>7,271</b>	<b>3,296</b>	<b>46,926</b>	<b>57,493</b>	<b>1,405</b>	<b>190</b>	<b>54</b>	<b>1,649</b>	<b>1,829</b>	<b>555</b>	<b>276</b>	<b>2,660</b>	<b>2,214</b>	<b>763</b>	<b>779</b>	<b>3,756</b>	<b>2,016</b>	<b>538</b>	<b>1,084</b>	<b>3,638</b>	<b>488</b>	<b>425</b>	<b>967</b>	<b>1,880</b>	
Canada	11	1	14	4,876	4,891	71	446	517	1	6	533	540		231	281	178	178			121	121					
<b>Total U. S. and Canada</b>	<b>258</b>	<b>7,272</b>	<b>3,310</b>	<b>51,802</b>	<b>62,384</b>	<b>1,405</b>	<b>261</b>	<b>500</b>	<b>2,166</b>	<b>1,830</b>	<b>561</b>	<b>809</b>	<b>3,200</b>	<b>2,214</b>	<b>763</b>	<b>1,016</b>	<b>3,967</b>	<b>2,016</b>	<b>538</b>	<b>1,262</b>	<b>3,816</b>	<b>488</b>	<b>425</b>	<b>1,088</b>	<b>2,001</b>	
<b>CLASSES OF EQUIPMENT:</b>																										
Postal	570	209	680		128			30	10		286	88	11	140	10	11	52	30	5							
Mail and Baggage	274	275	2,724		137	13	1	123	58	8	95	47	36	43	34	70	17	17	65							
Mail, Baggage and Passenger	32	20	679		22	10	3	9	2	4	3	12	4	6	7	7	4	17								
Baggage and Passenger	281	144	3,757		63	16		123	32	18	45	29	42	110	16	64	12	22	62							
Baggage or Express	854	881	7,431		121	43	32	188	90	89	233	280	173	324	99	89	86	171	162							
Passenger	2,801	1,323	23,692		432	97	11	866	302	126	887	244	413	726	333	505	260	158	281							
Parlor, Sleeping and Dining	1,707	338	6,864		384	9	4	396	51	13	640	36	94	648	37	316	33	22	365							
Business	11	58	774		4	2	1	5	10	10	3	15	4	1	2	15	1	1	9							
Motor	741	38	325		114		2	99	2	8	22	2	2	18		7	27		1							
<b>Total U. S.</b>	<b>7,271</b>	<b>3,296</b>	<b>46,926</b>	<b>57,493</b>	<b>1,405</b>	<b>190</b>	<b>54</b>	<b>1,649</b>	<b>1,829</b>	<b>555</b>	<b>276</b>	<b>2,660</b>	<b>2,214</b>	<b>763</b>	<b>779</b>	<b>3,756</b>	<b>2,016</b>	<b>538</b>	<b>1,084</b>	<b>3,638</b>	<b>488</b>	<b>425</b>	<b>967</b>	<b>1,880</b>		

## LEGISLATION RELATING TO OPERATION.

[WITH AN INSET.]

The Special Committee on Relations of Railway Operation to Legislation has compiled a table, which is reproduced herewith, showing the classification of bills introduced and laws enacted relating to railway operation in the state legislatures which were in session in 1913. The table shows that in 42 states in which the legislatures were in session 1,395 bills relating to railway operation were introduced, of which 230 were enacted. In 1912, when 19 legislatures were in session, including six special sessions at which no such legislation was introduced, 292 bills of this character were introduced, of which 48 were enacted into laws.

As in previous years laws relating to employees and equipment were most numerous among those passed. There were 48 laws relating to employees, of which 14 are full crew laws, 10 relate to service letters and time of payment, 9 to terms of employment, 8 to hours of service and 5 to experience. The next most numerous class of laws passed were those relating to equipment and to stations, of which 33 each were passed. Of the equipment laws 14 relate to headlights, and were enacted in 13 states. Of the station laws 20 relate to station equipment and 7 to track connections. Thirty-two laws were enacted relating to crossings, 13 with reference to separation of grades. Under the head of maintenance of way 22 laws were passed, of which 9 relate to track scales and weighing, 5 to fencing and 5 to double track. There were 18 laws passed relating to passenger trains, 7 with reference to the equipment and 5 with reference to drinking on trains. Only 8 laws were passed relating to freight trains, of which 5 concern the speed of livestock trains. Laws regarding trespassing were passed in six states—Arizona, Kansas, Michigan, Pennsylvania, Rhode Island and Washington.

Indiana led in the number of bills introduced, with 99, of which only 18 were passed. Minnesota led in the number of laws passed, 19 having been enacted out of the 58 which were introduced. In Wisconsin 80 bills were introduced and 17 enacted.

### REPORT ON BUTTING COLLISION AT BRANT, MO.

The Interstate Commerce Commission has issued a report, dated July 11, by Chief Inspector Belnap, on a butting collision of passenger trains which occurred on the Missouri Pacific at Brant, Mo., May 27, in which three employees and one mail clerk were killed and 48 persons were injured. The collision occurred at 3:49 a. m., and was due to a mistake by the train dispatcher in sending meeting orders, and to a station operator's fault in manual block signaling. The order sent to the eastbound train, No. 12, contained four meetings, while that sent to the westbound train, No. 11, contained only two. According to the report, this order was numbered 4 in both cases; and yet the meeting point for these two trains was given as McGirk's in one order and Tipton in the other. The order as received by No. 12 read as follows:

No. 3 Eng. 6409 meet No. 10 Eng. 5524 at Clarksburg and No. 12 Eng. 6415 at Tipton. No. 10 take siding No. 11 Eng. 112 meet No. 10 Eng. 5524 at Centretown & No. 12 Eng. 6415 at McGirk's.

As received by No. 11 it read,

No. 11 Eng. 112 meet No. 10 Eng. 5524 at Centretown and No. 12 Eng. 6415 at Tipton.

Tipton is 18 miles west of McGirk's and train No. 11 passed McGirk's, and the collision occurred two miles west of there. Both trains were running at about 40 miles an hour. The first car in No. 12 was a steel mail car; this was crushed for about half its length. The first car in the other train was a wooden

passenger car, empty, and this was wrecked and subsequently burned. Except for these two cars, no car in either train was knocked off the track. All of the cars in train No. 11 and four of those in No. 12 were returned to service by the same day.

The operator at McGirk's had authorized California, the next block station to the west, to send train No. 12 east; and then, about ten minutes afterward, admitted westbound train No. 11 to the same block, forgetting that he had pledged the block for the use of train No. 12. The report tells of conversations over the telephone as to where these trains were to meet, but no light is thrown on the cause of the operator's error. The testimony seems to be conflicting and the investigator offers no conclusion as to the explanation of the conflict.

The dispatcher had had fifteen years' experience as operator and dispatcher, and had a clear record on the Missouri Pacific since June, 1912. "His general condition and appearance, discrepancies on the train sheet on the day of the accident, and his total collapse after making a brief statement at the hearing, indicated that he was not in physical condition for the proper performance of his duties." As to what was the trouble with his physical condition the report gives no inkling. The operator at McGirk's had been employed nine years on many different railroads and had been discharged by the Chicago, Burlington & Quincy for using intoxicants. His record on the Missouri Pacific was clear. Whether or not these statements about the condition of the men are intended as hints that perhaps intoxicating liquor had something to do with this collision, does not appear. The report says nothing further on this point, but goes on to observe that as long as the human element is involved, errors will be made which will result in accidents; and that it is believed that the automatic block system is safer because it eliminates the human element in a greater degree.

The report says that Dispatcher Roach failed to obey a rule requiring him to send train orders simultaneously, but it has nothing to say about the repetition of the order. The dispatcher thinks he must have read, when sending to No. 11, that part of the order which refers to the meeting of No. 12 and No. 3.

### TRAIN OF 99 CARS HAULED 111 MILES BY ONE LOCOMOTIVE.

On July 11 last the Rock Island road hauled from Dalhart, Tex., to Liberal, Kan., a distance of 111.2 miles, a train consisting of 98 loaded cars and caboose, of which 95 cars were loaded with cantaloupes and three with red ball freight, in five hours with a single Mikado locomotive. The run was made for the purpose of testing the capacity of the company's new Mikados, of which 75 have been acquired in the last 15 months; and for the purpose of the test three trains arriving at Dalhart from Brawley, Cal., were consolidated into one. The line over which the run was made is on a generally descending grade for the entire distance Dalhart being 3,987 ft. above the sea level, and Liberal 2,853 ft. The maximum grade against the train eastbound was .8 per cent. This hill, at Beaver River, had to be doubled, making a delay of 38 minutes. The average time for the run was 22.2 miles per hour and the actual running time, excluding several stops, was 4 hrs. 4 min., making an average speed of 27.3 miles per hour while running. The regular schedule of the California gold ball train, the fastest freight train on the system, is 6 hrs. 10 min. for this run.

Locomotive No. 2,504, which hauled the train, has a tractive effort of 57,000 lbs., and the weight on drivers is 240,000 lbs., while the total weight of the engine is 320,000 lbs. The weight of the train was 3,770 tons, and its length 4,430 ft. The cantaloupes were packed in 30,805 crates, making a total of 1,277,000 melons, or a number equal to one for every person in the state of Kansas. The run was made with several tons of coal. There were three brakemen in the crew.







# ARE AMERICAN RAILROADS OVERCAPITALIZED?\*

Comparison With Conditions in Europe—Intrinsic Worth  
of American Properties—Need of Money for Improvements.

BY ALBA B. JOHNSON,

President of the Baldwin Locomotive Works.

Next to agriculture, transportation constitutes the largest industry of the country. Therefore the prosperity of the country depends, after abundant crops, upon the prosperity of the railroads. After the Civil War the country set about developing its great unsettled western country. For this development first railroads and then population were necessary. So great was the need for the first that extraordinary inducements were held out to capitalists to invest in railroad construction. These inducements were offered by the National Government, by states, by counties and by individual cities and towns. Rates of interest were high and the details of capitalization were scrutinized only by the investor, for at that time there was no public authority having jurisdiction over such matters. At that time the public at large was glad to have railroads on any terms. Now, however, a careful review is being made by economists and Government bureaus, of these details of railroad finance, to determine their effect upon present-day problems.

If those who believe American railways are seriously overcapitalized would study thoroughly certain facts, it is probable that most of them would conclude that they have attached too much importance to capitalization and would feel readier to co-operate for invigoration of railway credit through reinforcing railway revenue. The certainty of increased earnings for the railroads would do more for a restoration of national prosperity than any other factor conceivable. To start the roads into robust enlargement of facilities would feed many mouths, bless many regions, do much to steady business, postpone and minimize depressions and carry forward the widening of every man's selling area. This beneficent result is obstructed by the general delusion as to capitalization.

While President Brown, of the New York Central, was before the Interstate Commerce Commission in 1910, testifying for higher freight rates, an attorney of the shippers, Mr. James, was about to ask the witness his opinion of a statement in a book when Mr. Brown inquired, "What is that book?" Mr. James replied that it was *Chapters of Erie*, by Charles Francis Adams, written in 1871, the statements referred to being the passage on stock watering. Chairman (since judge) Knapp leaned forward and remarked in surprise:

"Do you mean seriously to intimate that the New York Central is overcapitalized?"

Sundry railway counsel, not appreciating the obstinacy with which the Adams fiber refuses to wither, and not knowing that this identical Adams, grandson of the sixth president and great grandson of the second, was at that moment in the prime of maturity at seventy-five, and capable of accepting summons and holding his own with any generation of interrogators whatever, jested on the point whether counsel would "produce Mr. Adams for cross examination," and whether he should be sought "above or below." So far back the lawyer had gone to find any competent authority to support his contention that the New York Central was overcapitalized.

The tradition of water securities is kept alive by a few classic instances. One earnest hydrophobe, who had heard that story about the New York Central, observed: "Please call Mr. Adams and ask him about \_\_\_\_\_," naming a railway company celebrated in recent times for stock jobbing.

Nothing is to be gained by issuing a clean bill of health to all roads since the discovery of the steam engine. If we are asked "Have American railway companies issued stock as a

bonus with bonds?" the answer is "Yes; because it was then necessary to attract investors and was consistent with the business standards of the time; the practice was once general. Moreover in some consolidations securities were issued to a par value greater than that of the combined issues previously outstanding; also, directors have been known to operate construction companies and to issue stock to buy property from themselves."

Facts are facts, and converts are not to be won by denying them. Charles P. Neill, until recently Government mediator in railway labor disputes, says that whenever he found the employer indignant, with reason, and reluctant to arbitrate, he began the acquaintance by acknowledging that it was "an outrage." The belligerent was at once his friend, and inquired, "What do you advise me to do?" "Yield!" said the mediator, and compromise or arbitration followed. A frank admission of what has been done in the past with regard to capitalization, leaving judgment upon it to individual temperament and to Heaven, is the first step toward getting together and seeing what, if anything, should now be done about it.

If, then, as viewed by some, construction companies ought not to have been employed, or employed on other terms, and the stock bonuses ought not to have been given, and the consolidations should have been accomplished, if at all, without increase of capital obligations, how serious have been the results?

Receiverships have wiped out millions of the original capitalization. There were many receiverships and many drastic reorganizations of railroads prior to 1894, but during that year 210 railroads, or twenty per cent. of all the railroads in the United States, were in the hands of receivers and their reorganization was later effected by the wholesale scaling down of their original capitalization. There are no statistics available to show whether in the aggregate this was equivalent to squeezing out all the water originally contained; but many of the best-informed statisticians believe this to have been the case.

## AN ILLUMINATING COMPARISON.

Earnings which could have been paid to stockholders, as is the custom in some other countries, have on American roads been put into the property without increase of capitalization. The old rule of the Pennsylvania Railroad Company was a dollar expended for improvements for each dollar disbursed in dividends to stockholders, and for years this practice was emulated by many of the most prosperous and conservative roads. In the twenty years, 1891-1910, the amount expended for terminal improvements and charged to income account aggregated no less than \$459,839,061. The rigid accounting system of the Interstate Commerce Commission was not put into effect until the fiscal year 1908, and in the years before that large sums were expended on the property and charged to operating expenses which now are required to be assigned to capital account.

Stock again, instead of being given as a bonus "representing nothing but blue sky," has to a large amount been sold for cash above par. The economist, Floyd W. Mundy, cites three cases, the New York Central, Baltimore & Ohio, and Pennsylvania, which, in 1913, he estimates had a total capital stock of \$934,242,088. Of this, \$547,770,653 was issued since 1900, upon which the cash realized was \$620,788,035. Three of our largest roads, he means, got an average of more than eight per cent.

\*Reprinted from *The Saturday Evening Post*.

premium on at least sixty-one per cent. of their total stock now outstanding. Among other effects of this policy it has served in the case of these companies to wipe out, many times over, any increases of capitalization through unearned stock dividends.

As a result of these two sets of forces—the sins of the fathers and the penance of the sons—is the burden of interest and dividends sufficiently excessive to require a readjustment of that situation before the matter of reinforcing railway credit and reinventing railway progress is undertaken?

Let us seek an answer by sweeping away the cobwebs of par value and per mile of line, which may mean anything or nothing, and applying a test, perhaps rarely used, but a test fundamental, comprehensive and conclusive. Let us ask: Are payments to capital excessive? There happens to be one foreign country, Great Britain, which has a considerable railway system, privately owned and operated, and yielding statistics comparable with those for the United States. How does our burden of payments to stockholders and bondholders compare with the British? What share of the receipts goes into dividends and interest on funded debt? The figures are as follows:

RAILWAY RECEIPTS AND PAYMENTS TO CAPITAL.	
United Kingdom, 1911.	
Receipts (returns to British Board of Trade, p. xix).....	£127,199,570
Total capital (do., p. xxiv).....	1,324,018,361
Average rate interest and dividends (do., p. xxvii).....	3.59 per cent.
Amount of interest and dividends (computed from above)...	£47,532,259
United States, 1910.	
Operating revenue (Interstate Commerce Commission Statistics of Railways, p. 70).....	\$2,750,667,435
Net revenue from outside operations (do., p. 70).....	2,225,455
Total receipts .....	\$2,752,892,890
Net interest (do., p. 69).....	370,092,222
Net dividends (do., p. 69).....	293,836,863
Interest and dividends .....	\$663,929,085

Comparison.	
Interest and dividends percentage of receipts:	
United Kingdom .....	37.3
United States .....	24.1

If capital had received from American railways the British proportion of total receipts, 37.3 per cent., instead of 24.1 per cent., as was the fact, the American distribution of interest and dividends in 1910 would have been \$364,772,072 more than it actually was.

Does this test of whether capitalization is or is not excessive afford an overwhelming motive for staying railroad progress in this country, while returns to owners and creditors of our roads are being scaled down?

To many, like the attorney above mentioned who wanted to call Mr. Adams and ask him about a specific road, averages for all the lines of each country compared may not be conclusive. To these, perhaps, one fact in the hand is worth two in the bush. Average statistics is the bush, and the particular instance known to him is the bird in the hand. How can we tell but that a considerable number of the principal American lines are carrying too heavy a burden of interest and dividend disbursements? Let us examine for his benefit an eastern and a western road which have been most criticized—Alton and Erie. What are the figures? Here they are:

NET DIVIDEND AND INTEREST PERCENTAGE OF RECEIPTS.	
United Kingdom (1911).....	37.3
United States (1910).....	24.1
Alton (1910) .....	25.8
Erie (1910) .....	17.3

These figures do not excuse wrongdoing, if wrongdoing there has been, but on the other hand do they furnish reason for blocking American railway leadership as a whole in the development of American industry, commerce, agriculture and territory?

Par value of capitalization should be mentioned, lest the omission be misinterpreted. Par value affords no secure basis of comparison. The usual method is to assign capital per mile of line. This is faulty, because it leaves unanswered the question, What is a mile of line? A mile of line on an average in Texas has only 58.7 per cent. as many lines of track as has

a mile of line in the statistical group situated in New York, New Jersey, Pennsylvania, Delaware and Maryland, only 23.2 per cent. as many locomotives and only 15.7 per cent. as many cars. So of terminal cost figures; the per-mile-of-line basis means little unless we know how many miles of line there are per terminal. If two roads have each two terminals, worth \$1,000,000 apiece, and one is 1,000 miles long while the other is but 500, then the 1,000-mile line has capitalization charged to its two terminals of \$2,000,000, or \$2,000 per mile of line, while the 500-mile road has a capitalization charged to its two terminals of \$2,000,000, or \$4,000 per mile of line. Cost of road construction again may be as low as \$20,000 a mile on the prairie and as high as \$250,000 a mile through the mountains, or \$1,000,000 a mile through the city. For this and other reasons comparison of capitalization is unsatisfactory. The facts, however, for what they are worth, are creditable to American railways by such a margin as fairly to raise the question whether any conceivable allowance for difference in conditions would offset it.

The Interstate Commerce Commission, by eliminating duplications, finds as the average net capitalization outstanding in the hands of the public a figure which is given in Statistics of Railways for 1910, page 52, as \$62,657 per mile of line. This compares as follows with capitalization in the principal foreign countries, the reduction to terms of American money, in view of the amounts involved, being figured on the precise basis laid down by the United States Bureau of Standards—\$4.8665 to the pound sterling, 19.3 cents to the franc, 23.8 cents to the mark—and reckoning 0.62137 mile to the kilometer:

CAPITALIZATION PER MILE OF LINE.		
	Amount.	Excess Over U. S. (Per Cent.)
United States, 1910 (Interstate Commerce Commission Statistics of Railways, p. 52).....	\$62,657	
Germany, 1911 (Statistik der Im Betriebe Befindlichen Eisenbahnen Deutschlands, p. 13).....	113,855	81.7
France, 1910 (Statistique des Chemins de Fer Français, pp. 334, 335).....	144,683	130.9
United Kingdom, 1911 (Returns to British Board of Trade, p. xxiv) .....	275,156	339.1
England and Wales, 1911 (Returns to British Board of Trade, p. xxiv) .....	328,415	424.1

These figures, showing an excess over American capitalization ranging from 81.7 per cent. in Germany to 424.1 per cent. in England and Wales, are averages for all roads. "Net capitalization," on the basis used by the Interstate Commerce Commission for all the roads consolidated in one account, is not easy to compute for individual American roads, owing to the interweaving network of subsidiary corporations. To deduct from the total for the given road the securities of other roads held in its treasury still leaves a sum higher than the "net" actually is, because there would remain to be deducted the securities held in the treasury of every subsidiary, and so on in an all but endless chain. But consider the primary elimination, deducting from the total for the parent corporation only those securities of other companies directly held by it. This shows that there is no American road of considerable size which is not capitalized at less than the British average. Of American roads two hundred or more miles long, that having the highest gross capitalization per mile is the Erie. Its net figure, after making the partial deduction above defined, is \$239,573. The United Kingdom shows an average for all lines 14.9 per cent. higher than the Erie; England and Wales 37.1 per cent. higher. The Alton net, thus figured, stands at \$129,413. The French average for all roads shows 11.7 per cent. higher than the Alton; United Kingdom 112.6 per cent., England and Wales 153.7 per cent. higher than the Alton.

#### THE SHOE ON THE OTHER FOOT.

Suppose it were the railways of the United States instead of the European lines which showed excess of capitalization per mile of line 81.7, 130.9, 339.1, 424.1 per cent.; would not the country visit condemnation upon our roads in good round terms? It is not good form in the United States to applaud

railways. I would not suggest the indecorum of Americans throwing up hats over their impressive accomplishment in keeping down the capitalization charges on transportation; but may not one reasonably ask whether "overcapitalization," according to world standards, has really been so flagrant in the United States as to constitute a national emergency? To meet it, ought the replenishment of equipment and the building of terminals for the accommodation of freight to wait?

Is the question of capitalization, then, as related to actual investment, to be ignored and railway managers left foot-free? The problem is receiving assiduous attention. Railways operating five hundred miles or more of lines which pass through states having statutes for the regulation of railway securities aggregate 198,854 miles, which is 94.6 per cent. of the total in the five-hundred-mile class. The Interstate Commerce Commission is at this moment, under mandate of Congress, inquiring into railway capitalization.

Is capitalization, in view of these elaborate and concerted efforts to regulate it, a problem which absolutely must be solved as a condition precedent to revision of freight rates, stiffening of railway credit and provision for handling the expanding business of a great and growing country?

Even when instrumentalities for the regulation of security issues shall have been perfected, how certain is it that capitalization, or the return thereon, has very much to do with freight rates or can be made to have? The Baltimore & Ohio, the Pennsylvania, the Erie and the New York Central operate for the most part under a rate structure, the basis of which is the through rate between New York and Chicago, identical for all four. This rate was fixed by competition, but once established it has been accepted as a standard of reasonableness, and rates between points where there is no competition are automatically influenced by that rate through custom and through the long-and-short-haul clause of the Interstate Commerce Act. The whole population served by these roads is, therefore, paying for its transportation at what may be termed the same rates. Assuming that the valuation now under way shall provide a means of judging accurately the cost of the properties, what prospect is there that these roads will prove to be "worth" even approximately the same? One has enormously expensive terminals in Chicago and New York, another not; one passes through many large cities where land is valuable and where elevated, depressed, tunnel and other costly structures have been frequent, another less so; one had to be carried over or under mountains, another traverses mainly a level country. Measuring the actual cost of the roads to the public by the sure test of the percentage of receipts paid to owners and creditors we find that the New York Central distributed in 1910 in net interest on funded debt and in dividends 11.2 per cent. of receipts; Erie, 17.3 per cent.; Pennsylvania, 13 per cent., and Baltimore & Ohio, 23 per cent. What, in the light of these figures, can capitalization have to do with freight rates?

#### JUSTICE TO RAILROADS.

The Interstate Commerce Commission, as it observed in the Eastern trunk line rate advance case, handed down through Commissioner Prouty, "is called upon to deal with rates as they exist, and in so doing we ordinarily consider them, not from the revenue standpoint, but rather from the commercial and traffic standpoint." He went on to declare, discussing the Baltimore & Ohio, Pennsylvania and New York Central: "Under rates reasonable for these three systems there may be lines whose earnings will be extravagant, but that is their good fortune. There may be lines which cannot make sufficient earnings, but that is their misfortune." The need of the average road was adopted by the commission as the test. Anxious citizens, who come to see that poverty for their railway means a handicap to those it serves, may inquire what an average road is. They will at least want the door left open for making the rate level adequate for the particular road on which they depend.

Possibly we have been splitting hairs. A new railway question confronts us requiring statesmanship for its solution. When it becomes clear to enough people that the railroads have before them, in enlargement of facilities and provision for safety, a task which must be done, and which cannot be done with money now available, the Interstate Commerce Commission will have before it the demand that this work be accomplished and that conditions be made such that the roads can obtain the capital. No single adjustment for one territory or for one year will suffice. What is required is a permanent policy of protection to railway revenues.

It is to be hoped this may become a national policy. To this end business men may well study the question of capitalization for themselves. Should they perceive that it is largely irrelevant to freight rates let them frankly admit it, they and their representatives in the legislative councils of states and nation.

#### TRAVELING ENGINEERS' ASSOCIATION.

The twenty-first annual convention of the Traveling Engineers' Association was held at Chicago, August 12-15, President W. H. Corbett, master mechanic, Michigan Central, presiding. After the opening prayer by the Rt. Rev. Samuel Fallows, D.D., the convention was welcomed to the city by Leon Hornstein, assistant city attorney. W. A. Garrett, vice-president, Chicago Great Western, made an interesting and enlivening address praising the good work done by the road foremen of engines.

President Corbett, in his address, spoke of the importance of the road foremen of engines as regards the handling of trains. He mentioned the great benefits that had been derived by these men from attending the conventions of this association.

The secretary reported a membership of 957, which is a gain of 75 members over last year.

The report on the uniform instructions to engineers on the handling of superheater locomotives was presented at the first session by a committee, of which J. W. Hardy, Chicago, Rock Island & Pacific, is chairman. Besides many valuable instructions to the enginemen a brief outline of the purpose of the superheater was included.

Wednesday's session included a report on the credit due to the operating department for power utilization and train movement that reduces the consumption of fuel per ton mile, by a committee, of which N. J. Howley, Erie, is chairman. This report clearly pointed out the various means by which the operating department can assist in reducing fuel costs. W. J. Tollerton, general mechanical superintendent, Rock Island lines, also addressed the association at this session. W. C. Hayes, superintendent of locomotive operation of the Erie, outlined those features of the Master Mechanics' June convention which were of special interest to the traveling engineers. A committee report on the subject of the care of locomotive brake equipment on the line and at the terminals, also methods of locating and reporting defects, H. A. Flynn, Delaware & Hudson, chairman, was read and discussed.

On Thursday the convention was addressed by D. R. MacBain, superintendent motive power, Lake Shore & Michigan Southern, and H. C. Bayless, mechanical engineer, Minneapolis, St. Paul & Sault Ste. Marie. A paper was read by Le Grand Parish, on the advantages obtained with the brick arch in locomotive service.

The last session was addressed by W. B. Storey, vice-president, Atchison, Topeka & Santa Fe, and a paper was read by J. H. Lewis, chief smoke inspector of the Chicago, Burlington & Quincy, on "What We Can Do to Eliminate the Black Smoke Evil on Locomotives." The standing committee on the revision of progressive examinations for firemen for promotion and new men for employment also made a report. A detailed report of the convention, with abstracts of the papers and committee reports will be published in next week's issue.

## DEPRECIATION OR VALUATION OF PROPERTIES.

By L. R. POMEROY.

The precise meaning of the word depreciation, or rather the precise financial process by which it is to be covered, varies so much, both in theory and practice, that for the present purpose it will be advisable to consider provision against depreciation merely as the setting aside of a definite fund to cover the amount which must be written off each year to allow for the gradual deterioration of the plant.

The falling off in value of a manufacturing plant, which takes place over a course of years, is due to two causes, of which the first is the actual employment on the work for which it is intended, and the second is the adolescence which may take place, due entirely to external developments, with which the plant has no relation. The first of these is usually known as depreciation, while the second is sometimes termed antiquation. While purchase value is perhaps affected by age and wear, rental or going value, in absence of decreased efficiency, is not.

In 1908 James Edward Darbishue read a paper before the Institute of Mechanical Engineers (England), on the subject of "Depreciation of Workshop, Plant and Machinery." This paper aroused great interest and was fully discussed by prominent authorities. The curves shown in Fig. 1 are plotted from those

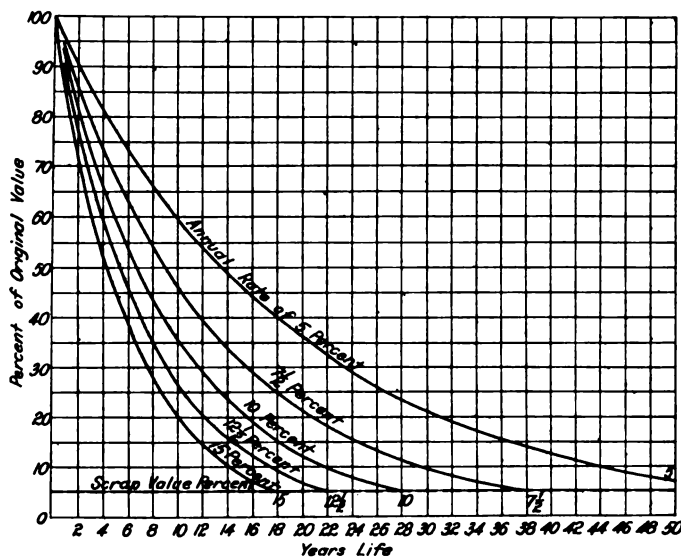

Fig. 1—Depreciation Curves Plotted from Those Presented by Mr. Darbishue.

presented in that paper and were the basis of the discussion. This form of depreciation is also used by Matheson, the celebrated English authority, in his book on the "Depreciation of Factories and Their Valuation."

The amount of depreciation shown by any rate,  $x$ , selected from these curves is a varying one, because it is not a constant rate for every year. It diminishes year by year, by  $x$  per cent. on the last or previous year's value. Assuming a rate of 10 per cent. it would take a period of 28 years for the amount to reach the scrap value (5 per cent. of the machine).

While it was admitted that a 10 per cent. rate was a fair one it was thought that the amount should be so adjusted as to be at a lesser rate for the early life of the machine and gradually increasing more rapidly during the latter life of the machine, the curve ending at the scrap value just as the regular curve for 10 per cent. does.

Fig. 2 is presented to show among other things, the comparison of curves based on these ideas. Curve *A* shows the regular 10 per cent. depreciation, while curve "*A modified*" represents the adjusted curve suggested. The modification is based

on, or follows the curve on the diagram representing the assumed profit value of the machine.

A comparison of the various methods in use leads the writer to recommend and emphasize the curve shown in Fig. 2, plotted from the formula presented by Mr. McKay in the May issue of *Machinery*, for the reason that it takes into account the replace-

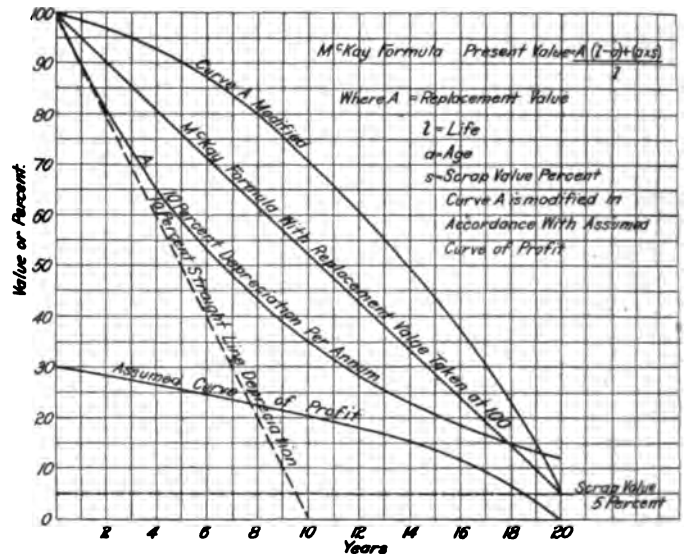

Fig. 2—Comparison of Values by Different Methods.

ment value of the tool or machine, which in all fairness is a consideration to which the plant is intrinsically entitled. If another type of machine is selected to replace the old machine, the difference in cost of the new machine over the replacement value of the old machine may be properly considered a betterment and can be capitalized.

Following is an example or illustration of the value found by the various methods given on the basis of 20 years' life, showing the values at 5, 8, 10, 18 and 20 years:

10 Per Cent. Straight Line Depreciation. Per Cent.	10 Per Cent. Curve A. Per Cent.	Curve A Modified. Per Cent.	McKay Formula Replacement Value 100 per cent. Per Cent.	McKay Formula Replacement Value 120 per cent. Per Cent.
50	59	90	76	91

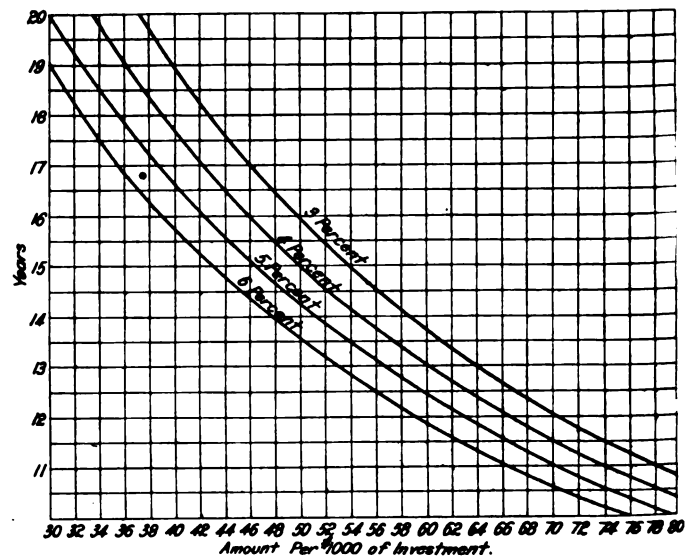

Fig. 3—Curves for Computing Sinking Fund Payments.

20	43	80	62	74
0	35	70	52	62
0	15	23	15	18
0	12	5	5	6

The above bears more directly on valuations and appraisals or applies to the starting of an inventory as the basis of a systematic method of handling depreciation in connection with general accounting. It would seem, however, that the sinking fund method is preferable, as it provides an automatic plan of extinguishment of the initial investment, at a predetermined life, by furnishing a fund which, at the termination of this life, is equal in amount to the original investment and forms a replacement fund.

Fig. 3 gives curves for computing depreciation or sinking fund payments for interest compounded annually. These curves show: First, the annual payments per \$1,000 invested to repay the original outlay at the end of a given number of years and, second, the term of amortization, i. e., years. When a given amount per \$1,000 of principal or per cent. is paid into the sinking fund annually, the formula is as follows:

$$\text{Annual rate } x = \frac{R}{(1 + R)^n - 1}$$

and for the number of years:

$$N = \frac{\log \frac{R + x}{x}}{\log (1 + R)} \text{ where}$$

- N = Number of years or term of amortization.
- R = Rate of interest received.
- x = Rate of depreciation charge or annual sinking fund installment in dollars per dollar.

For example, assume the life of a tool, machine or plant to be 20 years. Then the annual sum at 5 per cent. interest compounded, set aside each year to absorb the investment, equals \$30 per \$1,000 of principal or 3 per cent. For 15 years' life, \$46.40 or 4.64 per cent.; or the amount and rate being given the term of years can be read directly from the curves. Suppose the amount to be 5 per cent. or (\$50 per \$1,000) compounded at 5 per cent. Then the number of years, from the diagram, that this given amount at 5 per cent. will absorb the original investment is 14.25 years.

**NEW PASS FORM FOR ROCK ISLAND LINES.**

The Rock Island Lines adopted on July 1 a new form of trip pass both for exchange purposes and for employees' use, designed by E. A. Fleming, chief clerk in the office of the president. The new form was adopted primarily on account of the

saving of time and labor which it was believed it would afford in the issuance of passes in offices where large numbers are handled, and also for the purpose of more effectively preventing misuse by various methods which have been practiced to a considerable extent.

The illustration shows both the face and reverse sides of the pass form. It will be noted that there are three sections of approximately the same size, divided by perforations. The pass folds at these lines of perforation, and, by means of two pieces of carbon paper, the face of the pass, the reverse side of the central section, and the face of the recording coupon are written at one operation. The central section is further divided into two coupons that are to be used for comparative checking and identification purposes, and are to be taken up and returned by conductors when the pass is first presented for passage on both the going and return trips. These coupons, when the pass is written, will show on the reverse side that part of the trip, going or returning, that they represent.

The pass proper provides spaces for either one way or round trip, or two separate trips if preferred, as it is not essential that the return trip be between the same points as the going trip. Space is also provided for showing the residence address of the holder of the pass and via what route the trips are to be made. The recording coupon, after being written, should afterwards be endorsed in the proper space to show the name of the officer issued by and by whom requested. No year will be shown on the pass except as is required in writing it, thus making the pass good for use during any ninety day period. The prefix letters now used in numbering will also be done away with by reason of the fact that no two trip passes of any class will bear the same number. The new issue of passes will begin with No. 25,001 and run consecutively for several years. Only annual passes will bear numbers below 25,001.

The forms are supplied in sheets (of five passes each) padded together, and in single form bound 50 passes per book; the former to be provided where they can be used to advantage. Passes may be written either by typewriter or with indelible pencil. When they are furnished in books a blank form is inserted to be used by the issuing office for reference after the recording coupons have been turned in.

The pass proper is to be retained by the holder until the trip shown thereon is completed.

The new form has been approved by the Interstate Commerce

<p>No.</p>	<p><b>Rock Island Lines</b></p> <p><small>THIS PASS SUBJECT TO CONDITIONS ON BACK AND VARIOUS ARTICLES IN THE RULES AND REGULATIONS</small></p> <p>Pass _____ Account _____</p> <p>ADDRESS _____</p> <p>GOING TRIP                      RETURN TRIP</p> <p>FROM _____ FROM _____ TO _____ TO _____ VIA _____ VIA _____</p> <p>ISSUED _____ 19                      ISSUED _____ 19</p> <p>VALID WHEN COUNTERSIGNED BY _____</p>	<p>No.</p> <p><small>CONDUCTOR'S EMPLOYMENT CONTRACT</small></p> <p>On the RETURN TRIP the first Conductor to whom the pass is presented shall take the same up and return it to the issuing office. The name of the Conductor receiving the coupon for the return trip shall be written in the space provided for that purpose.</p> <p>NAME _____</p> <p>ADDRESS _____</p>	<p>No.</p> <p><small>CONDUCTOR'S EMPLOYMENT CONTRACT</small></p> <p>On the RETURN TRIP the first Conductor to whom the pass is presented shall take the same up and return it to the issuing office. The name of the Conductor receiving the coupon for the return trip shall be written in the space provided for that purpose.</p> <p>NAME _____</p> <p>ADDRESS _____</p>	<p><b>RECORDING OFFICE COUPON—C</b></p> <p><small>EXCHANGE PASS</small></p> <p>No. _____</p> <p>PASS _____ ACCOUNT _____</p> <p>ADDRESS _____</p> <p>GOING TRIP                      RETURN TRIP</p> <p>FROM _____ FROM _____ TO _____ TO _____ VIA _____ VIA _____</p> <p>ISSUED _____ 19                      ISSUED _____ 19</p> <p>COUNTERSIGNED BY _____</p> <p>ISSUED BY _____</p> <p>REQUESTED BY _____</p>
------------	---	---	---	--

<p><b>INSTRUCTIONS</b></p> <p>THIS FORM OF PASS IS INTENDED FOR USE PRIMARILY WITH A TYPEWRITING MACHINE BUT CAN ALSO BE WRITTEN WITH A HARD LEAD PENCIL, INDELIBLE PREFERRED. PEN AND INK SHOULD NOT BE USED.</p> <p>AFTER ISSUING PASS ATTACH COUPON "C" TO THE REQUEST OR AUTHORITY FOR ISSUANCE AND MAIL PROMPTLY TO THE PRESIDENT OR SECOND VICE-PRESIDENT.</p> <p>RETURN ENTIRE PASS WHEN CANCELLED OR SPOILED IN ISSUING. IT IS IMPERATIVE THAT CARE BE TAKEN IN WRITING PASSES TO INSURE GOOD, LEGIBLE COPIES.</p> <p>REGARD OF ALL PASSES ISSUED SHOULD BE MADE ON THE BLANK FORMS IN THE BACK OF THIS BOOK.</p>	<p><small>IF CHANGED OR ALTERED PASS WILL BE FORFEITED</small></p> <p>PASS _____ ACCOUNT _____</p> <p>GOING TRIP                      RETURNING TRIP</p> <p>FROM _____ FROM _____ TO _____ TO _____ VIA _____ VIA _____</p> <p>ISSUED _____ 19                      ISSUED _____ 19</p> <p>HONORED _____                      HONORED _____</p> <p>TRAIN _____ DATE _____                      TRAIN _____ DATE _____</p> <p><small>NOT APPLIED FOR                      CONDUCTOR                      NOT APPLIED FOR                      CONDUCTOR</small></p>	<p><small>GOOD OVER LINES OF THE CHICAGO, ROCK ISLAND &amp; GULF RAILWAY BETWEEN POINTS NAMED ON FACE OF PASS</small></p> <p><i>W. A. Fleming</i> CHIEF CLERK OF THE BOARD</p> <p><b>CONDITIONS</b></p> <p>THIS PASS IS NOT TRANSFERABLE, IS FORFEITED IF ISSUED BY OTHER THAN THE OFFICIAL NAMED HEREON, OR IF ANY ALTERATION, ADDITION OR ERASURE IS MADE THEREON, AND MAY BE REVOKED WITHOUT NOTICE BY THE AUTHORITY AND THE USE AND EXTENSION OF THIS PASS IS WHOLLY AT THE DISCRETION OF THE OFFICE OF ISSUANCE. THE HOLDER OF THIS PASS SHALL BE RESPONSIBLE FOR THE PROTECTION OF THE SAME AND SHALL BE LIABLE FOR THE FULL VALUE OF THE SAME IN CASE OF LOSS OR THEFT. THE PASS IS VALID ONLY FOR THE PURPOSES AND UNDER THE CONDITIONS SPECIFIED HEREON.</p> <p>I ALIEN TO THE ABOVE CONDITIONS.</p> <p>SIGNATURE OF HOLDER _____</p> <p><small>ISSUES OF THIS PASS MUST BE MADE IN THE SETTING SHOWN HEREON</small></p> <p>PLACE OF RESIDENCE _____</p> <p><small>Conductors will accept passes below in order specified. First Conductor must have short and valid No. or a check on continuous trip and return-over.</small></p> <table border="1" style="width: 100%; border-collapse: collapse;"> <tr> <td>RETURNING</td> <td>DATE</td> <td>TRAIN</td> <td>1</td> <td>2</td> <td>3</td> <td>4</td> <td>5</td> <td>6</td> </tr> <tr> <td>GOING</td> <td>DATE</td> <td>TRAIN</td> <td>1</td> <td>2</td> <td>3</td> <td>4</td> <td>5</td> <td>6</td> </tr> </table>	RETURNING	DATE	TRAIN	1	2	3	4	5	6	GOING	DATE	TRAIN	1	2	3	4	5	6
RETURNING	DATE	TRAIN	1	2	3	4	5	6												
GOING	DATE	TRAIN	1	2	3	4	5	6												

Face and Reverse of New Rock Island Pass Form.

Commission, and special authority has been granted to the Rock Island Lines for its adoption, with the request that advice be given as soon as may be possible of the results obtained in connection with its use.

It has now been in service for several weeks and has proved entirely satisfactory, not only saving time in the office, but causing no confusion in its handling by the conductors.

**AROUND THE WORLD IN THIRTY-SIX DAYS.**

John Henry Mears, a representative of the New York *Evening Sun*, arrived in New York City on the evening of August 6, after traveling around the globe in thirty-five days, twenty-one hours, thirty-five minutes and four-fifths of a second, or within less than one second of the time which was calculated before the journey was begun. Mr. Mears says that he averaged 587 miles a day, 24.5 miles an hour, and that the distance traveled was 21,066 miles. The shortest day's travel was 287 miles, from London to Paris; and the longest was 955 miles, on the last day of the journey, from Indiana Harbor to New York; and this occupied only 21 hours 18 minutes. He says that the most serious dangers he encountered were in Siberia, where an infuriated railroad officer [conductor] threatened him, and on Puget Sound, where he transferred from a steamer to a hydro-aeroplane.

The last stage of the railroad journey was by the Empire State Express from Buffalo to New York. This train was delayed near Albany, by reason of damage to track by heavy rain, but reached New York, on time, at 10:10 p. m. From the station at New York to the office of the *Sun*, about three miles, the trip was made in automobiles, in about five minutes, officers of the police department riding in another car ahead, to make sure of a clear road.

From the fragmentary accounts printed in the *Evening Sun* we gather the data given in the tables below. It will be seen that the distance from Chicago to New York is overstated by about 12 miles.

While the trip was completed in the time calculated, there were a number of serious delays, but these were made up by changing routes and by other devices. Mr. Mears says that railroad and steamship officers were uniformly accommodating, except in the case above noted. In the first stage of the journey, the voyage across the Atlantic, there was a delay of several hours by reason of fog. In Siberia there was a delay of 18 hours because of a washout. For several days after this Mears was liberal in his payments of money to the locomotive engineers. Between Victoria, B. C., and Seattle there was a fog and before landing at Seattle he transferred to an aeroplane. At Cleveland, Ohio, the train was delayed just outside the station, and Mears traveled a short distance on foot to make his connection with the train east from Cleveland.

*Original Itinerary.*

Lv. <i>The Evening Sun</i> Office, July 2.....	12:45 a. m.
Ar. Cunard Line Piers, July 2.....	12:59 a. m.
Lv. New York by <i>Mauretania</i> , July 2.....	1:00 a. m.
Ar. London, July 7.....	1:00 a. m.
Lv. London, July 7.....	9:00 p. m.
Ar. Paris, July 8.....	5:50 a. m.
Lv. Paris, July 8.....	1:45 p. m.
Ar. Berlin, July 9.....	7:29 a. m.
Lv. Berlin, July 9.....	7:15 p. m.
Ar. Moscow, July 11.....	3:50 p. m.
Lv. Moscow, July 11.....	10:30 p. m.
Ar. St. Petersburg, July 12.....	9:15 a. m.
Lv. St. Petersburg, July 12.....	2:25 p. m.
Ar. Harbin, July 20.....	11:40 p. m.
Lv. Harbin, July 21.....	1:00 a. m.
Ar. Vladivostok, July 21.....	8:20 p. m.
Lv. Vladivostok by boat, July 21.....	9:30 p. m.
Ar. Tsuruga, July 23.....	3:30 p. m.
Lv. Tsuruga, July 23.....	7:40 p. m.
Ar. Yokohama, July 24.....	8:23 a. m.
Lv. Yokohama by <i>Empress of Russia</i> , July 24.....	4:00 p. m.
Ar. Victoria, Aug. 2.....	8:00 a. m.
Lv. Victoria, Aug. 2.....	8:30 a. m.
Ar. Seattle, Aug. 2.....	1:45 p. m.

*Original Itinerary. (Continued.)*

Lv. Seattle, Aug. 2.....	7:10 p. m.
Ar. St. Paul, Aug. 5.....	7:55 a. m.
Lv. St. Paul, Aug. 5.....	8:30 a. m.
Ar. Chicago, Aug. 5.....	9:00 p. m.
Lv. Chicago, Aug. 5.....	11:30 p. m.
Ar. Cleveland, Aug. 6.....	7:50 a. m.
Lv. Cleveland, Aug. 6.....	7:50 a. m.
Ar. Buffalo, Aug. 6.....	11:45 a. m.
Lv. Buffalo, Aug. 6.....	1:00 p. m.
Ar. New York, Aug. 6.....	10:10 p. m.
Ar. <i>The Evening Sun</i> Office, Aug. 6.....	10:20 p. m.
Total time—35 days 21 hrs. 35 min.	

The itinerary was changed to cut out Moscow, Vladivostok and Tsuruga.

*Distances.*

New York to Ambrose Lightship.....	Miles. 28
Ambrose Lightship to Daunt's Rock Lightship.....	3,397
Daunt's Rock Lightship to Fishguard.....	144
Fishguard to London.....	261
London to Paris.....	287
Paris to Berlin.....	672
Berlin to St. Petersburg.....	1,022
St. Petersburg to Irkutsk.....	3,492
Irkutsk to Harbin.....	1,533
Harbin to Chang Chun.....	152
Chang Chun to Mukden.....	189
Mukden to Antung.....	170
Antung to Fusan.....	583
Fusan to Shimonoseki.....	150
Shimonoseki to Tokio.....	704
Tokio to Yokohama.....	17
Yokohama to Victoria.....	4,871
Victoria to Seattle.....	100
Seattle to St. Paul.....	1,907
St. Paul to Chicago.....	411
Chicago to New York.....	976
Total.....	21,066

St. Petersburg was the point furthest north on the route, 60 deg. north latitude. Shimonoseki was the point furthest south, 34 deg. north latitude. The difference is 26 deg. It will be noted that layovers of considerable length were scheduled at a number of points, for example: London, 21 hours; Paris, 7 hours, 55 minutes; Berlin, 11 hours, 46 minutes, etc. If any one thought it worth while to engage special trains and steamships the circuit of the globe could be made, evidently in much less time than 35 days.

*Names of Carriers.*

- Cunard line, from New York to Fishguard.
- Great Western Railway, from Fishguard to London.
- , London to Calais.
- Northern Railroad, from Calais to Paris.
- Eastern Railroad, from Paris to Franco-German line.
- Prussian State Railroad, from the international line to Berlin and thence to the Russian line.
- Russian State Railroad, from the Russo-German State line to St. Petersburg, and thence to the Trans-Siberian, and the Trans-Siberian line to Harbin.
- South Manchurian Railway, from Harbin to Mukden.
- Chosen Railway, from Mukden to Fusan, Corea.
- Imperial Japanese Railway (and steamer), from Fusan to Yokohama.
- Canadian Pacific steamship *Empress of Russia*, from Yokohama to Victoria.
- Seattle Yacht Club and Christopherson's hydro-aeroplane, from William Head and Race Rocks, Puget Sound, to Seattle.
- Northern Pacific Railroad, from Seattle to St. Paul.
- Chicago & North Western, from St. Paul to Chicago.
- Lake Shore & Michigan Southern, from Chicago to Buffalo.
- New York Central & Hudson River, from Buffalo to New York.

The *Evening Sun* prints the records of previous around-the-world journeys as follows:

Name.	Record				Date.
	Years.	Days.	Hrs.	Min. Sec.	
Magellan Expedition.....	3	..	..	..	1519-1522
Capt. W. D. Seymour.....	..	117	..	..	1876
Nellie Bly.....	..	72	6	11 14	1889
George Francis Train.....	..	67	12	3	1890
Charles Fitzmorris.....	..	60	13	29 42½	1901
Henry Frederick.....	..	54	7	20	1903
Col. Burnley Campbell.....	..	40	19	30	1907
Andre Jaeger-Schmidt.....	..	39	19	42 37½	1911
John Henry Mears.....	..	35	21	35 ½	1913

The journey of Col. Campbell was the first made over the Siberian Railroad. Mears, it will be noted, crossed the Pacific ocean in nine days, a much quicker voyage than was possible prior to the advent this year of the new and fast steamers of the Canadian Pacific Railway.

# Maintenance of Way Section.

THE statistics of bills introduced and laws enacted in state legislatures during 1913, published elsewhere in this issue, show that maintenance is a subject not entirely overlooked in the present crusade of legislative regulation. The measures directly affecting the maintenance department are classified in the tabulated statistics under four heads: clearances, crossings, maintenance of way—general, and stations. In the 42 state legislatures which met in 1913, 362 bills were introduced under these four heads, of which 90 became laws. The equipment of stations apparently concerns the legislators more than any other item in these groups, for 70 bills were introduced and 20 laws passed on this subject. Forty-three bills were introduced and 13 laws passed governing the separation of grades at railway crossings and three laws were enacted specifying clearances as a result of the introduction of 13 bills. The state of Minnesota holds the individual record in legislative activity from the standpoint of the maintenance department with 32 bills introduced and 13 passed. Indiana is a close second, however, with 32 introduced and six passed. Only 14 legislatures met in 1912, so that a direct comparison with the showing made last year is difficult, but the fact that only 50 bills were introduced and five laws passed in 1912 under the four heads mentioned, shows that the average record per state for 1913 is more than double that of last year.

WE venture to prophesy that in point of attendance, quality of reports and discussion and size and value of the exhibit, the 1913 convention of the Roadmasters' and Maintenance of Way Association to be held in Chicago, September 9-13, will be fully up to past performance, if it does not establish some records. Now as to the facts which justify such a prophesy. The association gained nearly 25 per cent. in membership last year by adding 125 members. In spite of this phenomenal record, the increase so far this year shows that the numerical growth by the time the convention meets will be even greater than last year. A large membership means a large attendance, provided the meetings are interesting and are held at a point convenient to a large percentage of the members. The work of the officers and committees assures an interesting program. Following the precedent established last year of cutting down the number of subjects, only five reports will be presented and good live discussions should be brought out on each subject. Chicago is one of the easiest cities in the country to reach, and a large percentage of the membership of the association is on roads which terminate in Chicago. As to the exhibit, it is enough to say that 50 firms have already reserved space as compared with 39 at Buffalo last year.

COMPARATIVELY few roads have facilities for carrying on tests of track devices and forms of construction in a systematic manner. The suggestion made by Mr. Milner, in his article in this issue, that the railways co-operate in establishing and maintaining an experimental track, has some sound arguments in its favor. In studying the stresses in track, which would be one of the first problems to be considered at such a testing plant, some reliable and valuable data should be secured. Very few engineers would be willing to assert that our present standard construction is the only one which has merit, although practically all efforts to increase the strength of track to take care of increased loads have been made along the line of strengthening the individual elements of the existing track, rather than in starting with basic principles and designing a structure to meet the requirements. Thorough tests of other types of con-

struction might well repay the effort. Such a testing station could also handle all tests of track, switch and signal devices much more advantageously than the individual roads. The value of many devices is dependent largely on the conditions under which they are used, and if tests can be made where there are facilities for varying all the conditions affecting a device, as would be the case at such an experimental station, the true merit of the device may be determined. The length of time required to secure results in an ordinary service test is too great in most cases to make the test practicable. A special test track can be subjected to much more frequent train movements, thereby decreasing the required time very materially. In order to place any confidence in experimental data, the observations must be made by men who are qualified and trained to handle such work. The average service test can at best be inspected only at intervals by the chief engineer or other responsible officer, and the success or failure of the device may depend entirely too much upon the individual preference of the roadmaster or foreman in charge of the section on which the device is installed. A testing station could be put in charge of a well qualified man, possibly at one of the large engineering schools, as suggested by Mr. Milner. The German station mentioned in the article has found it necessary to withhold all data referring to the relative merits of devices from publication on account of the controversies that are started by manufacturers when their devices do not show up well and the unduly colored advertisements which may be used by the owners of favored devices. It might not be as easy to handle this phase of the matter in a station maintained by the co-operation of a number of roads as it is at the German station maintained by the government. It is difficult to anticipate the attitude of manufacturers toward such a comprehensive system of tests, but the firms that have devices of merit certainly would have nothing to fear, and others would deserve the disfavor which such tests would bring upon them. The cost of building and maintaining such a station would be excessive for any one road, but it ought to be small enough to make it an excellent investment if it could be entered into by a number of roads, preferably through such an association as the American Railway Engineering Association.

## CHEAPER FUEL FOR PUMPING ENGINES.

THE increase in the cost of gasoline during the last two or three years has increased the cost of operating many gasoline pumping plants at water stations practically to the level of steam plants. It is a difficult matter to give average figures for the cost of gasoline, either at present or in past years, from which to determine the exact amount of the increase that has taken place. The price which railways pay is fixed largely by local conditions, the competition of small independent companies keeping the price relatively low in some instances. The price paid is fixed by contract covering very large quantities of this fuel so that the cost to small users is not an index of that to the railways. In some instances the price paid for gasoline used at certain pumping stations is even less now than it was three years ago, for instance, but in the great majority of cases the present prices show increases, some of which are as much as seven cents per gallon, or even more. The average increase is variously estimated at from 25 to 40 per cent.

The gasoline engine has proved its value in the water service department, especially for small installation, and a large number of plants of this type have been successfully operated. The general use of these engines makes the increase in the price of gasoline very important to water service men. If the price con-



tinues to increase—and on account of the limitations of the supply and the phenomenal increase in the use of the automobile, the indications are that it will—either present engines will have to be replaced by steam or electric plants or some other fuel will have to be found which can be economically used in the internal combustion engine. Since the latter alternative involves a much smaller outlay for new equipment than would be necessary to install steam or electric plants, it is very much to be favored and both manufacturers and water service men are giving their best efforts to the development of oil engines and attachments which will allow crude oil, kerosene, motor spirits, or some other cheaper form of fuel to be used in the gasolene engines which the roads already own. The advances that are being made in the use of oil engines for pumping water are well described in Mr. Knowles' paper elsewhere in this issue. It would seem from the figures presented by him that a fair start has been made toward the satisfactory solution of the problem.

The necessity for securing cheaper fuel for internal combustion engines is being discussed by users of gasolene motors throughout the world. One of the most thorough investigations of future supplies of hydro-carbon motor fuels and of substitutes for hydro-carbons, was presented in two papers before the Imperial Motor Transport Conference at a recent meeting in London. These papers define motor spirits, one of the fuels used in Mr. Knowles' experiments, as any easily evaporated combustible liquid sufficiently volatile to form an explosive mixture with air at a moderate temperature. This would include a great many oils among which are a number of the distillates of petroleum. By a process called "cracking," which heats hydro-carbons until they split into lighter carbon and hydrogen or into other hydro-carbons, many oils which would otherwise not be suitable for fuel can be utilized.

Other motor spirits which have already been utilized to some extent are obtained from shale oil and bituminous and cannel coal. Certain coal tar oils may be made available for use as motor fuel by processes of cracking, the commercial availability depending, as in most of the other substitutes that are being suggested, on the ability to market the by-products which are obtained in their production.

One of the papers referred to recommended the use of alcohol very strongly. While Mr. Knowles' tests, published in this issue, show that alcohol is not economical for oil engine fuel, he indicates, in commenting on the tests, that the engine used was not adapted to alcohol. The author of one of the English papers maintains that motors can be properly designed to burn alcohol at a very low cost. It seems certain, however, on account of the present price of alcohol, the lack of suitable alcohol motors and certain corrosion troubles which are experienced in its use, that for the immediate future at least, relief will be sought in some of the power distillates.

#### RECLAIMING MAINTENANCE SCRAP.

**A** FEW roads which are paying special attention to the utilization of second-hand and scrap material are effecting material economies. Most roads have adopted some system of collecting scrap at frequent intervals and section gangs are required to assemble it at central points on their sections, to be picked up by the train making such collections. However, this practice is by no means universal, and there are still some roads that make no organized effort to prevent the loss of this material. A recent inspection of a yard on an eastern road revealed large quantities of bolts, spikes, tie plates, as well as couplers, brake beams and other car parts scattered about between the tracks. If this condition is typical of the entire road, many thousand dollars are being needlessly wasted, as the value of this material would repay the cost of its collection several times over.

The relaying of rail has been practiced almost universally, and

a second use of track fastenings is usually obtained, but there are still opportunities for improvement in the handling of such material to get the greatest value from it. We have called attention more than once to the operation of rail sawing plants and rail inspection and classification yards, and elsewhere in this issue is published an article on the collection and handling of second-hand rail on branch lines, which includes some excellent suggestions.

The reclaiming of maintenance scrap, other than rails and angle bars, has not been generally attempted, and in fact the reclaiming of small scrap in other departments has been largely a local matter at division points or terminals. A number of roads, however, are establishing scrap depots and reclaiming shops to handle the scrap collected from the entire road, and the results of the operation of these shops show that large economies can be effected by such a method. In a great many cases, track material and tools are discarded and get into the scrap pile, which are not usable in the condition in which they are found, but which would not require extensive repairs to make them as good as new. The Lackawanna, for instance, finds that over 50 per cent. of all material other than rails and angle bars which is sent in as scrap can be put back into service after making some slight repairs, thus increasing its value from that of scrap to new material. The Southern Pacific has for some time been making tie plates, angle bars, spikes and other track fastenings from various forms of scrap iron. The Sacramento shops, which handle this work, turn out about 1,700,000 tie plates each year in addition to the other classes of material that are manufactured. In this case no definite figures of the savings can be arrived at, as these are dependent on the assumed prices credited to the various departments for scrap material used at the shop. It is known, however, that a considerable saving is made.

The most complete scrap reclaiming plant that has been developed is operated by the Santa Fe at Corwith, Ill., just outside of Chicago. The operation of this shop and the savings which have been made are described in considerable detail in an article in the general section of this issue. While a very large part of the material handled at Corwith is car and locomotive scrap, there are a number of interesting features in connection with the handling of maintenance scrap. No rail intended for relaying comes to Corwith, as the company operates a rail sawing mill at Newton, Kan., which handles all necessary work on second-hand rail.

The fact that all of the material handled at Corwith consists of smaller parts makes the savings that have been effected all the more noteworthy. For instance, it would seem that there would be considerable question as to the advisability of trying to reclaim track spikes and nuts, but it has been found that spikes can be reclaimed at a cost which, including the value of the scrap and all charges for operating the plant, is \$1.33 per keg less than they can be bought for in the market. In the same way nuts can be reclaimed for \$3.81 a keg less than their value new. The savings made on a few other typical items are as follows: \$1.08 each for ballast forks, \$0.84 each for claw bars, \$14.80 each for track drills and \$5.32 each for jacks. As an indication of the magnitude of the work which is done on maintenance scrap the value new of this material, which was reclaimed during 1912, was a little over \$39,000.

In most cases the material is repaired by putting together the good parts of several pieces. The rust is removed from spikes by rattling them, and they are then straightened and sharpened. In some instances articles for use in the maintenance department can be made from scrap car and locomotive parts. In this manner picks are forged from old coupling pins and jimmy bars are made from coil springs that are too weak to be used again. By handling all scrap at one shop it is possible to make the best use possible of each piece of scrap without interfering with the proper accounting between departments.

# A MAINTENANCE DEPARTMENT TESTING PLANT.\*

A Suggestion for Increasing the Amount of Experimentation on Track Constructions as an Aid to Scientific Design.

By B. B. MILNER.

Some time ago the writer, whose experience has been chiefly with railway motive power, was asked to assist a maintenance-of-way engineer in the investigation of a problem which involved a study of track design and the stresses imposed upon its various members. Consultation with several men of recognized experience and authority, as well as an investigation of all experimental work performed in this connection, and a search through the literature of the subject, revealed the fact that dependable data upon which to base definite conclusions upon various points raised were lacking. This same revelation was made by O. E. Selby, bridge engineer of the Cleveland, Cincinnati, Chicago & St. Louis, in writing an admirable paper, entitled "A Study of

in 1899, by Railroad Director Schubert, of Berlin, of observations extending over a period of over three years, on the action of ties actually in track. This report was translated and published by W. C. Cushing, chief engineer, maintenance of way, Pennsylvania Lines, and appeared in Bulletin No. 76 of the American Railway Engineering Association, June, 1906.

In Mr. Johnson's formulæ the two following premises are made:

1. "That the width of distribution of the load is equal, for stone ballast, to the width of the tie plus the depth of the ballast, and, for gravel ballast, to the width of the tie plus half the depth of the ballast."

From Fig. 2 this premise may be algebraically expressed thus:

$$\begin{aligned} \text{For gravel, } x &= b' + \frac{1}{2} d' \dots\dots\dots (1) \\ \text{For stone, } x &= b' + d' \dots\dots\dots (2) \end{aligned}$$

where  $x$  is the width of the ballast pyramid carrying the load.

2. "That the intensities of pressure within that width are proportional to ordinates to an arc of a circle whose radius and chord are each equal to the width of distribution of the load."

The deduction of the formulæ is as follows:

If the circular arcs be considered as approximate parabolas, the intensities of pressure may be assumed to be proportional to the ordinates of the curves. The area of the parabolic segment  $= \frac{2}{3}xy$ , hence the mean ordinate  $= \frac{2}{3}y$ ; or the mean pressure  $= \frac{2}{3}$  the maximum.

The pressure at  $b$  is 0, hence, to obtain an approximately uniform distribution of pressure over the surface of the subgrade, the tie-spacing  $S$  must be such that the curves overlap and have a common ordinate  $y'$  equal to  $\frac{1}{2}y$ . This will obtain when  $db = \frac{1}{4}cb$ ;  $eb = \frac{1}{4}ab$  or  $mo = \frac{1}{4}mn$ .

Hence, the tie-spacing  $S = \frac{3}{4}x$ .

Therefore, from (1), for gravel,

$$S = \frac{3}{4} (b' + \frac{1}{2} d')$$

and from (2), for stone,

$$S = \frac{3}{4} (b' + d')$$

from which the required ballast depths  $d'$  are obtained by transposition:

$$\begin{aligned} \text{For gravel, } d' &= \frac{8}{3} (S - \frac{3}{4} b') \\ \text{For stone, } d' &= \frac{4}{3} (S - \frac{3}{4} b') \end{aligned}$$

both of which give values of  $d'$  much greater than exist in practice.

The question whether, in order to strengthen our tracks for

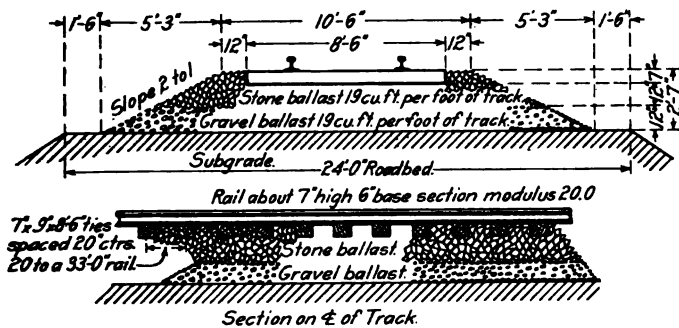

Fig. 1—Track Superstructure for 60,000 lb. Axle Loads.

the Stresses Existing in Track Superstructure and Rational Design Based Thereon," which was published in Bulletin No. 80, American Railway Engineering Association, October, 1906. This paper contained several paragraphs elaborating upon the statement that "railroad track has grown in strength as heavier loads have made increased strength necessary, but such growth has been entirely along empirical lines, and not one single detail of track superstructure bears marks of engineering design."

After careful consideration of such factors as rail loading and stress therein, tie bending, bearing of tie upon the ballast, depth of ballast and its bearing upon the subgrade, Mr. Selby developed the track design shown in Fig. 1. The sizes on the drawing are for 60,000-lb. axle loads. The principal sizes for 50,000-lb. loads, using various weights of rail, are given in Table I.

TABLE I.

Rail	80 lbs.	90 lbs.	100 lbs.	Rail with Sec. Mod. 20
Axle load	50,000 lbs.	50,000 lbs.	50,000 lbs.	60,000 lbs.
Size of ties	7 in. x 8 in. x 8½ ft.	7 in. x 8 in. x 8½ ft.	7 in. x 8 in. x 8½ ft.	7 in. x 9 in. x 8½ ft.
Spacing of ties	16½ in.	18 in.	20 in.	20 in.
Number of ties per 33 ft. rail	24	22	20	20
Depth of ballast	14 in. stone	16 in. stone	18 in. stone	12 in. stone; 12 in. gravel
Width of roadbed	21 ft.	21 ft.	22 ft.	24 ft.

From this table it is at once seen that the number of ties per 33 ft. rail, as well as the depth of ballast, is much greater than that found in standard track today, and, since the figures in the table are the result of a careful consideration of the strength of the materials involved, it is not surprising that the question of strengthening our present standard tracks is becoming such a live one, especially with our heavier trunk lines.

The depth of ballast, computed by Mr. Selby, was obtained from formulæ for the thickness of ballast necessary to produce equal distribution of axle loads on the surface of the subgrade beneath the ballast, for which Thomas H. Johnson, consulting engineer of the Pennsylvania Lines West, was responsible. Mr. Johnson deduced these formulæ after studying a report, made

the increased loads imposed, the number of ties or the depth of ballast, or both, should be increased, is one on which opinions vary widely among those concerned. The following is here presented in this connection:

Fig. 3 shows a diagrammatic section of the ordinary standard main line track, in which 7 in. by 8 in. ties are spaced 22 in. apart, or 18 per 33-ft. rail, and laid upon 6 in. of ballast. The slopes of the ballast pyramids, transmitting the load from the bottom of the tie to subgrade, are determined in accordance with Mr. Johnson's premises for the distribution of pressure at the bottom of stone ballast. It will be noted that the width of the base of the ballast pyramid under each tie is 14 in. and the width of the strip of subgrade unloaded and lying between adjacent ties is 8 in. As shown by Director Schubert's experiments, and in line

\*Abstracted from the Journal of the Franklin Institute for July, 1913.



and speed, etc., and must do this upon subgrade of given conditions. With a sufficient amount of the right kind of data, it should be possible to combine the knowledge of the loads to be imposed with that of the subgrade conditions, and prescribe the most efficient and economical track construction, which, if it cannot be immediately provided, can be approached from year to year in connection with regular track maintenance work. Subgrade conditions vary materially within short distances, but with these conditions properly charted it should be a very easy matter, in bringing the condition of the track up to a desired standard, to concentrate effort upon those sections which are farthest from that standard and which will be located from tabulated or charted data or from the frequency of service failure.

Opinions of maintenance men vary greatly upon a majority of questions relating to track and track superstructure design, and practically none of these opinions is supported by such conclusive test or experience as will make early agreement or reconciliation possible. In the maintenance-of-way department dependable data are not being collected as in the motive power department, in which department much money has been, and is continually being, profitably spent to settle questions pertaining to the design and operation of both locomotives and cars, many of which questions are of less importance than some of those relating to track construction.

The writers upon maintenance-of-way subjects will have served a useful purpose if they succeed in focusing attention upon the

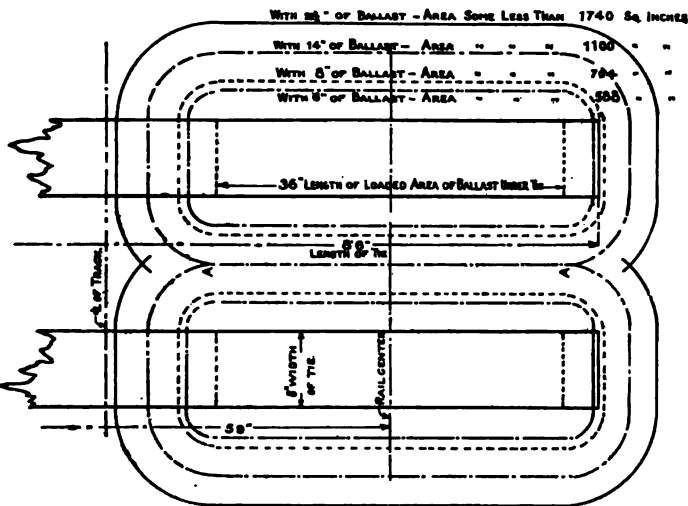

Fig. 5—Sketch of Track Plan.

comparative deficiency of experimental work in this field, for as soon as this deficiency is realized work will be inaugurated which will in a few years elevate the science of track construction to its proper level. The condition of our tracks is now lagging behind requirements, and we cannot consistently hope for a better state of affairs unless some move along scientific lines is soon inaugurated. In the meantime, locomotive and car designers must "mark time," so far as increased loads and speeds are concerned.

While some investigations should necessarily be made under regular service, many can be (and a few have been) carried out upon an experimental track of significant proportions. An experimental track was constructed a comparatively short time ago by the Prussian State Railroads at Oranienberg, Germany, and is being used to determine experimentally the best construction. Dr. H. K. Hatt, of Purdue University, who visited this installation a few years ago, reported:

"It consists of an oval track two miles in circumference over which runs a train consisting of an electric locomotive and cars. At about every 50 ft. two vertical rail ends were sunk in the ground on each side of the track and clips riveted onto them to serve as a reference line for measurement of track deformation.

The service is considered as severe in one year as eight years on the main line. The cost of the roadbed and equipment is stated to have been \$40,000.

"The records of traffic passing over this experimental track show that in 369 working days the number of ton miles was about 3,700,000. In the months of January, February, March and April, 1909, there were nearly 4,350,000 ton miles. The locomotive weighed 59½ tons and would pull a train of from 240 to 375 tons. The speed of the train was about 37 miles per hour."

The loads imposed upon this experimental track are insignificant in comparison with those which, for the results obtained to be of service, would have to be placed upon such a track in this country. The writer would suggest that an experimental track be designed and constructed in the form of a figure 8, so that one loop could be operated while the other was being prepared for test. On this track, properly enclosed by fencing, etc., a motor, hauling any desired combination of cars, loaded with any desired axle loads, could be controlled from the office of an engineer of maintenance-of-way tests located in the center of either of the loops, and in this way any combination of rails, fastenings, ties, joints, ballast, frogs, switches, signals and safety devices could be tested.

The value of an ability, by this method, to rapidly test rails of different steels, under more scientific conditions, must be apparent when the amount of work done in settling rail questions during the last ten years is considered. Such a plant, with its so general benefits, could very properly be jointly constructed by interested railroads, perhaps under the direction of the American Railway Engineering Association, and tests on it carried out by some one of our educational institutions interested, in much the same way that motive-power department tests of various equipment furnished by different railroads, directly or indirectly through the Master Car Builders and Master Mechanics' Associations, have for some years been conducted at Purdue University, Lafayette, Ind.

ABSTRACT OF ENGINEERING ARTICLES SINCE JULY 18.

The following articles of special interest to engineers and maintenance of way men, and to which readers of this section may wish to refer, have appeared in the regular weekly issues of the *Railway Age Gazette* since July 18, 1913:

Extensive Improvements on the L. & N.—The Louisville & Nashville has under way extensive double tracking, grade revision and realignment work covering more than 300 miles of line and involving two distinct projects. The first of a series of two articles describing this work, which covers interesting construction details of the improvements between Nashville, Tenn., and Birmingham, Ala., was published in the issue of July 25, page 143. The second article describing improvements to the old line and the building of certain sections of new line between Winchester, Ky., and Jackson, was published in the issue of August 8, page 225.

Long Island Improvements at Jamaica.—The elevation of the Long Island tracks through the city of Jamaica, L. I., has been complicated by the necessity for separating grades of intersecting branches without interruption to a very heavy passenger traffic. The work included some unusual structures and a modern passenger station. August 1, page 183.

New Engine Terminals on the Western Maryland.—Two engine terminals recently built by the Western Maryland at Hagerstown, Md., and Maryland Junction, W. Va., were described in the issue of August 1, page 189.

Development of the East Indian Railway.—In an article of a general nature covering the growth of an East Indian line that now operates 2,500 miles, a number of details of construction were included. The article was published in the issue of August 1, page 191.

"Cotton Belt" Freight Terminal at St. Louis.—The new freight terminal of the "Cotton Belt" at St. Louis, including a reinforced concrete freight house, team tracks, scales, cranes and other equipment, was described in the issue of August 8, page 218.

Electric Trucks in Freight House Service.—The economies to be secured by the operation of electric freight trucks were well brought out in a description of a number of installations of these trucks published in the issue of August 8, page 236.

# NEW YORK CENTRAL IMPROVEMENTS AT ROME.

Realignment Made Necessary by Construction of Barge Canal  
Involved Street and Stream Crossings and a New Station.

By EMILE LOW,  
Consulting Engineer, Buffalo, N. Y.

The New York Central & Hudson River, east of Syracuse, N. Y., roughly parallels the Erie Canal, although between the crossing west of Canastota and that at Rome, the canal and the railroad are as much as four miles apart at places. The original Erie Canal, which was begun at Rome on July 4, 1817, crossed the divide between the Mohawk river and Wood Creek at Rome at its lowest point, its water elevation being 3 ft. lower than the present canal. When the first enlargement of the Erie Canal was made in 1845, its location at Rome was shifted to the north

largely of copper and brass works and allied industries, and also the Rome Locomotive Works. The notable exception is the Rome Rolling Mill on the Erie Canal which has track connection with the New York, Ontario & Western. This railroad and also the Rome, Watertown & Ogdensburg, now a branch of the New York Central, connect with the New York Central at the present passenger station.

When the Barge Canal became a certainty, its location at Rome was a serious problem. The proposed ship canal from

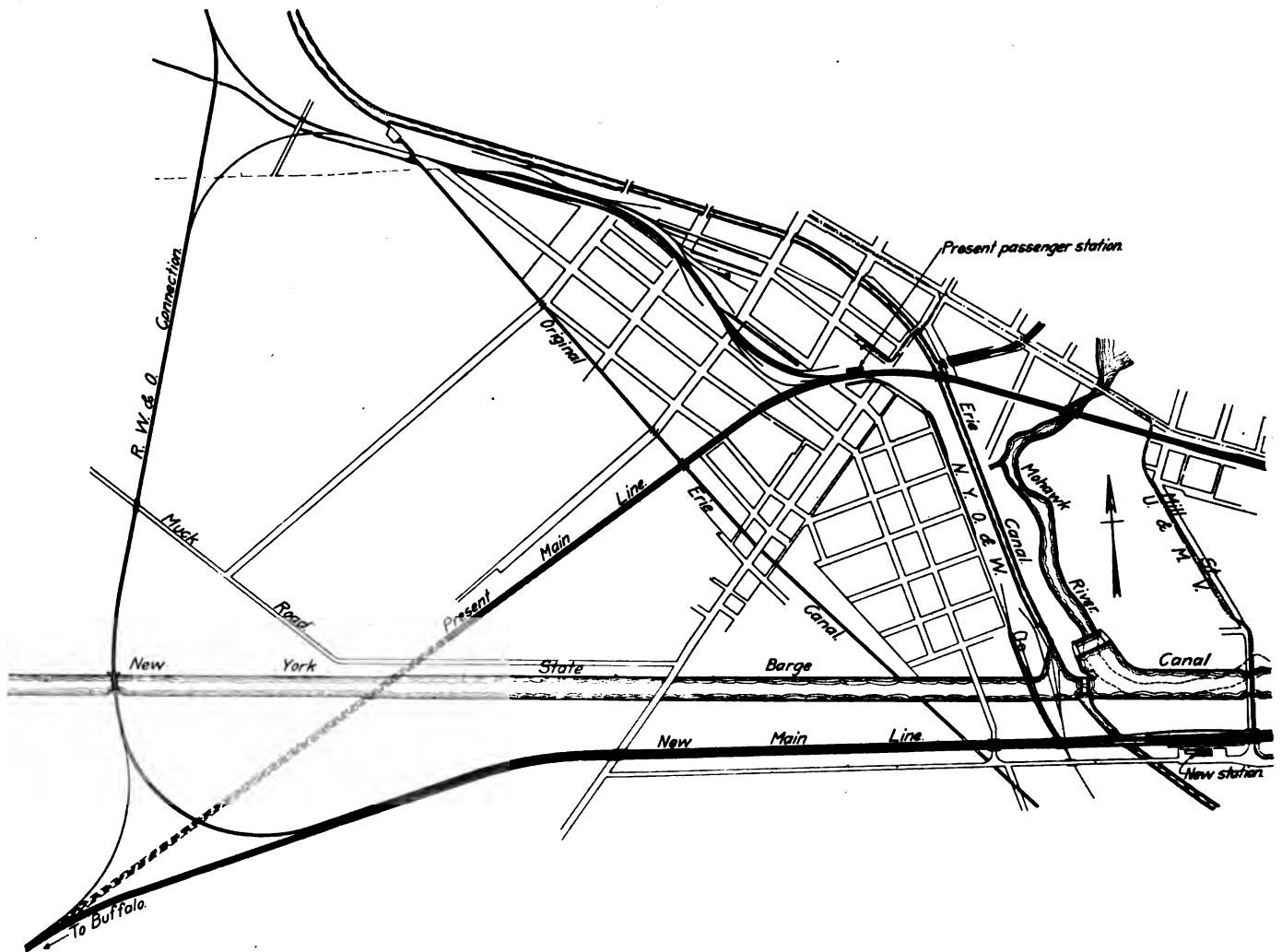

Partial Plan of New York Central Improvements at Rome, N. Y.

about one-half mile, skirting along the foot of a slight declivity forming the southern boundary of the town. It then turned to the south, intersecting the original canal at a small settlement known as Stanwix on the south of the valley.

The New York Central crosses the present canal nearly at right angles, just east of the station at Rome and just west of the crossing of the Mohawk river. It recrosses the river about four miles east of Rome, running along the south bank to beyond Utica.

As in many other towns, the main industries of Rome are located along the line of the present railroad, nearly all east of the passenger station, on both sides of the track; they consist

Oswego to the Hudson river was located years ago south of Rome, with two draw bridges to carry the New York Central. The writer had charge of the location of the Barge Canal at this point during the years 1904-7, and his first examination indicated that a relocation of the New York Central south of the present line was imperative with the Barge Canal about 500 ft. north of and parallel to the revised line.

After every possible location had been surveyed this plan with slight modification was adopted and is now being executed. The new line leaves the old about 9,000 ft. west of the present passenger station, by a 1 deg. 30 min. curve to the right, the curve being followed by a tangent about 3,000 ft. long, then another 1

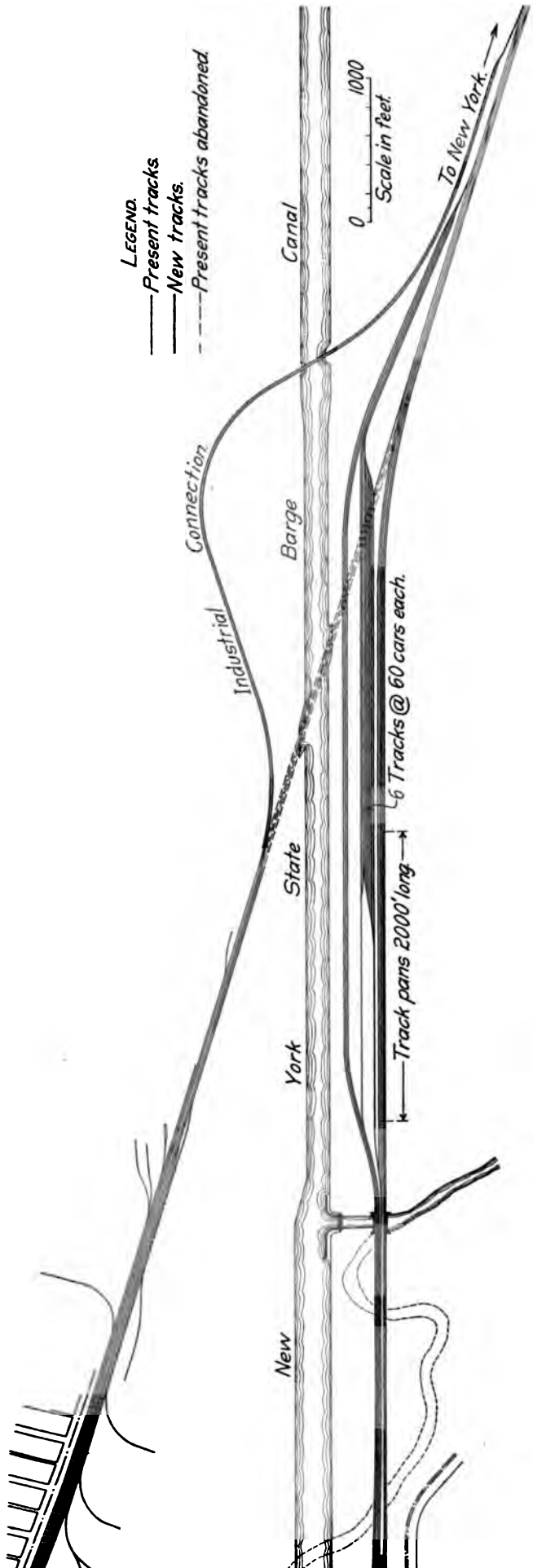

Remaining Portion of Plan on New York Central Improvements at Rome, N. Y., but on a Larger Scale Than the Portion Shown on the Opposite Page.

deg. 30 min. curve to the right, followed by a tangent over two miles long at the end of which a connection with the present line is made by a 1 deg. curve, the total length of the improvement being about four miles. A new connection with the R. W. & O. is being made at the eastern end of the main line change, and from this connection east the four tracks of the N. Y. C. & H. R. and the two of the R. W. & O. are side by side, making a six track line. These tracks cross James street, the old Erie Canal, Lawrence street, the New York, Ontario & Western and the present Erie Canal.

Immediately east of this canal crossing and between it and



Building the Skew Arch Over the Present Erie Canal.

Mill street is located the new passenger station on the south side of the railroad, facing a new street connecting Mill and James streets. The tracks are numbered from the south to the north. The most southerly one is the eastbound passenger, No. 2, the westbound passenger, No. 3, the westbound freight, No. 4, the eastbound freight, and Nos. 5 and 6 the R. W. & O. The island platforms will be 1,200 ft. long, one between tracks 2 and 3 serving the westbound New York Central passenger track and one between tracks 5 and 6 serving both R. W. & O. tracks. The platforms are reached by a subway and stairs. The station will be a brick structure 210 ft. long x 50 ft. wide, with all accom-



Double Arch Over Mill Street and the U. & M. V. Electric Railway.

modations for passengers on the street level. It will be set back from the tracks a sufficient distance to allow the embankment to take its natural slope and passengers will reach the track platform along the eastbound main by a covered bridge from the second story of the station.

The main waiting room will be in the east end of the building, reached directly from the street by two large doors on the south side. The ticket office, which will be 40 ft. long, is located between these doors; the women's retiring and rest rooms occupy the entire east side of the main waiting room and the men's

smoking and toilet rooms, the west side. The west end of the building will be occupied by baggage and express rooms. The stairways to the eastbound track will be inside the main waiting room and the subway to the westbound track will be entered from the main waiting room level under these stairways.

Beginning about 3,000 ft. east of the station, a six track yard with a capacity of 360 cars is located between the two freight tracks. The two N. Y. C. passenger tracks and the eastbound freight track continue straight, the other three being shifted far enough to the north to make room for the yard. A new industrial connection is being built at the east end of the improve-

located along them, and also to preserve the present connection between the New York Central and the Rome, Watertown & Ogdensburg.

The new connection for the latter road leaves it about one mile northwest of the old passenger station, just south of the crossing of the old Eric Canal, running due south about 1½ miles across the Barge Canal to a connection with the New York Central at the western end of the improvement. By means of "Ys" both easterly and westerly connections are secured. A "Y" connection is also made at the R. W. & O.

The new main line is entirely on embankment, ranging from

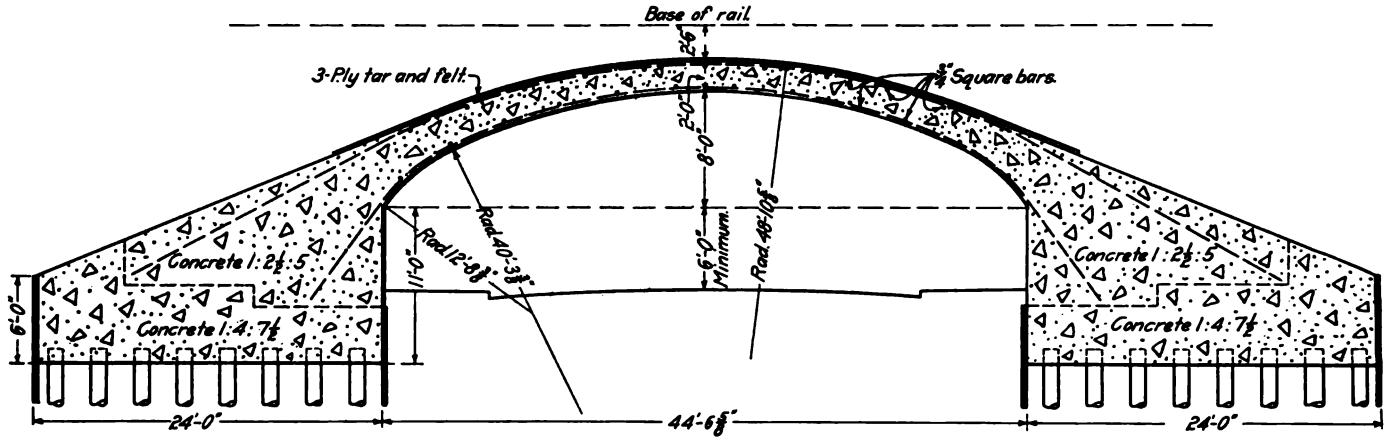

Longitudinal Section of James Street Arch.

ment. It leaves the main line about 2½ miles east of the present passenger station, bearing to the right across the Barge Canal and connecting by a reverse curve with the present tracks east of the Rome Locomotive Works. This diversion was made necessary on account of the limited head room at the present crossing of the Barge Canal, and also because of the acute angle of crossing. The map shows that about one mile of the present tracks is retained west of the old passenger station and about two miles east of it, to serve the many industrial establishments

10 to 20 ft. high, built from material pumped from the adjacent Barge Canal by a hydraulic dredge. This section of the canal is known as Contract No. 43 and extends from Oriskany to Rome. The contractors are the M. A. Talbot Company of Baltimore, Md. The hydraulic dredge known as the "Stanwix" used on this work was built by the Morris Machine Works, of Baldwinsville, N. Y., and has a 20 in. suction and discharge. It began operations in July, 1911, and by January, 1913, had pumped 1,107,110 cu. yds. of material, partly sand, gravel, clay and muck.



Discharge Pipe and New Embankment Being Made by Dredge.

Dikes thrown up by Lidgerwood excavators are used to retain the pumped material.

All highways are crossed overhead. The James street crossing is a reinforced concrete three centered arch, built on a skew of 53 deg. 54 min. It is 123 ft. long; the arch span is 36 ft. and the rise 8 ft. Bed rock in this vicinity is about 70 ft. below the ground surface and bearing piles are required for the support of the abutments. The piles are 35 ft. long, spaced 3 ft. in the rows and 2.5 ft. between the rows, each of the two abutments being supported by 319 piles. The normal width of the abutments is 19.5 ft. at right angles to the center line of the street and 24 ft. parallel with the center line of the arch. They are 4 ft. high on the inner faces and 8.5 ft. and 6 ft. at the back, with one step of 18 in., and another of 3 ft. The concrete in the footing and skewback is 1:4:7½.

The thickness of the arch at the crown is 24 in., at the end of the flat curve 30 in., and at the springing line, on line with the radius, 4 ft. The skewback, which is a large mass of concrete with its top tangential to the flat arch, impinges against the offsets of the foundation concrete, this weight with that of the superimposed embankment resisting the arch pressure. The transverse reinforcement for the intrados and extrados of the arch consists of ¾ in. square bars, spaced 10 in. center to center.



Hydraulic Dredge Working in New Barge Canal South of Rome, N. Y.

The longitudinal reinforcement consists of the same sized bars spaced 4 ft. center to center, staggered top and bottom. The arch concrete is 1:2½:5. The top of the arch ring and back of spandrel walls are waterproofed with three ply tar and felt, covered with a 1 in. coat of 1:2 Portland cement mortar. The top of abutments and back of wing walls are waterproofed with a ½ in. coat of straight run coal tar pitch. The base of rail is 2 ft. 6 in. above the top of the arch.

The Lawrence street crossing is of the same type as the one at James street. The clear span is 36 ft., and the crossing is square. The number of bearing piles is 456. The crossing of the present Erie Canal is on a skew of 40 deg. 23 min. The span taken normal to the canal is 35 ft., with a rise of 8 ft. The other general dimensions are the same as the James street arch, except the length of the barrel. A tow path is provided for on one side of the canal.

At the crossing of Mill street and the Utica & Mohawk Valley Electric a double arch is used. The Mill street arch is a counterpart of the Lawrence street arch, except in some unimportant details, the clear span being 36 ft., and the rise 9 ft. 4 in. The U. & M. V. arch has a clear span of 24 ft. and a rise

of 5 ft. 6 in. There is also a crossing of the Mohawk river consisting of two 40 ft. arch spans at the Barge Canal spillway, and other minor structures at the Muck road and original Erie Canal crossing.

The crossing of the Barge Canal on the Rome, Watertown & Ogdensburg connection is a double track bridge with two deck plate girder approaches. The crossing is slightly skewed and the canal at this point is 130 ft. wide, which is 55 ft. more than the normal width. The two piers are founded on 74 bearing piles each, variously spaced from 30 to 42 in., a maximum loading of 20 tons per pile being allowed for. The concrete in the pier stems is 1:3:6. The copings are 1:1:2.

This improvement work is being carried out under the direction of George W. Kittredge, chief engineer of the New York Central & Hudson River and allied lines.

### A MACHINE CAR FOR CONSTRUCTION WORK.

In connection with the construction of the North Coast lines in Washington, a machine car was built to provide repair shop facilities for general use in connection with the laying of new track or other construction work remote from such facilities. The car is 39 ft. 10 in. long, 9 ft. 6 in. wide and 9 ft. high, in-



Exterior of North Coast Machine Car.

side dimensions. It was equipped with a 12 h. p. Fairbanks-Morse oil cooled vertical gasolene engine, which was connected to a friction clutch and to the wheels of the car by sprockets



Interior of Machine Car.



and chain, making it self-propelling. In actual practice this car did considerable light switching and moved from one station to another under its own power, being able to maintain a speed of 8 or 10 miles an hour.

Among the tools contained in the car were one 23 in. engine lathe, one 16 in. shaper, one 1½ in. bolt cutter, one 6 in. pipe threading machine, one emery wheel and one 22 in. vertical drill. With these tools, practically all kinds of repair work incident to track laying and ballasting operations was carried on. About 4 gal. of gasolene were required to run the shop machinery upon the average repair work with two men working for a period of 12.5 hours. The car was found to be very efficient and useful upon the work when properly operated and maintained.

### REINFORCED CONCRETE TELEGRAPH POLES.\*

On the New York terminal division of the Pennsylvania a concrete pole line has been built along the right-of-way across a continuous five-mile stretch of semi-tidal swamp-land known as the "Hackensack Meadows." The ground surface is covered with a heavy growth of reeds, and the top stratum is a peaty bog from 8 to 15 ft. deep, underlain with varying strata of clay, fine sand, and mixed sand and clay for very considerable depths. The problem was to provide a design of pole which would not only be strong in itself, but which could be set in a stable foundation in soft and uncertain ground. It was desired to make the line entirely secure against interruption by severe storms or by fires in the swamp reeds. It appeared, under these conditions, that the ordinary type of wooden pole would not be wholly satisfactory, either as regards strength for such heavy service, or safety as regards the frequent meadow fires.

Reinforced concrete poles seemed to be adapted to the purpose, but very little reliable data about either the cost or service from such design was obtainable. A simple form of reinforced concrete pole was designed which could be manufactured on or near the work at a cost which would not be prohibitive. Without previous data to go upon, the design was somewhat experimental, and probably will not be of very great assistance in fixing a precedent for an ordinary telegraph pole, as the conditions called for heavier construction than usually required for such lines.

The line required 202 poles, spaced from 70 to 135 ft. apart, with an average standard spacing of 120 ft., the variations in span being due to numerous railway and highway crossings. The height of the top of poles above the ground also varies from 25 to 50 ft., and the total length of poles from 35 to 65 ft. The loading called for an ultimate capacity of 60 open telegraph wires, two 40-pair telephone cables, and one signal control cable. The open wires are of copper, No. 7 and 8, B. & S. gage, and the cables No. 13 and 16 B. & S. gage insulated wires, with a lead covering. The cables are carried by steel messenger wires. The weight of the wires and cables is 10½ lbs. per running ft., giving a total loading for the average span of 1,268 lbs. per pole, or, including cross-arms, insulators, brackets, and fittings, 1,500 lbs. per pole. In addition to this static vertical loading, emergency conditions were assumed of an extra loading of ½ in. of ice on the wires and a wind pressure of 8 lbs. per sq. ft. on wires and 13 lbs. per sq. ft. on the poles. The stresses under these conditions are not to exceed the elastic limits of the wires and of the carrying structures. These assumptions are equivalent to a vertical loading of 7,600 lbs. per pole and a horizontal force of 4,000 lbs. exerted one foot below the pole top. The normal sag of the wires at 60 deg. F. temperature is 4½ in., and a normal tension of 273 lbs. for No. 8 wires and 130 lbs. for No. 9. The maximum hot sag at 130 deg. F. is 11 in.; the tension in the

wires under maximum wind-pressure with the ice loading and at 20 deg. F., is 702 lbs. and 470 lbs. respectively, for the two sizes of wires.

The design adopted is that of a tapering smooth-surface, reinforced concrete pole, square in cross-section, with chamfered corners and having a taper of ½ in. in 5 ft. The concrete is of 1½:2:4 mixture, assumed to have an ultimate strength in compression of 2,000 lbs. per sq. in. The reinforcement is composed of mechanical bond bars tied into a square skeleton frame, and in the complete pole this reinforcement is covered by a 1-in. minimum thickness of concrete.

In order to manufacture the poles economically, a yard was established adjacent to the right-of-way and with sidetrack connections for delivery of materials. The ground was leveled and set with stringer pieces, 3 ft. apart, of old wooden car sills, so as to furnish a convenient surface upon which to erect timber forms. This yard permitted of the simultaneous manufacture of 6 poles and the storing in place of 90 poles during the period of seasoning. In the process of manufacture the skeleton reinforcement is first made up, the twisted steel mechanical bond bars being tied together to form a square skeleton frame; this frame is then suspended at the proper height above the ground and the sectional wooden frames put in position around it. The concrete mixture is then poured in and carefully tamped. In this way six poles were made per day and were left in place at least sixteen days to season.

After a number of experiments it was found best to set the poles in pits excavated in the marshy stratum. These pits were generally about 9 ft. square and 5 ft. deep. A timber grillage was placed around the base of each pole about 5 ft. below the top of the ground. This grillage consisted of 6 cross ties bolted together and to the pole, and partly planked over by 3-in. rough lumber. The pole, which projected below the grillage and was pointed at the butt, was jetted down by compressed air into the sandy layer, so that the grillage would rest at the bottom of the pit. The pits were then backfilled with rock and clay. Poles on curves are cross-guyed, and the terminal and railway crossing poles are head-guyed with steel cables.

In order to determine the stability of the foundations, as above described, as well as the transverse strength of the pole itself, a test was made of a 55-ft. pole set in a 13-ft. foundation. The test consisted in applying a horizontal pull 39.5 ft. from the ground. The breaking load was 4,360 lbs., and the point of fracture 20 ft. from the ground, at the top of the 32-ft. reinforcement bars. The foundation itself was found to be amply secure.

The actual cost of labor and material for manufacture of these poles, reduced to a unit cost for an average length pole of 40 ft., weighing 7,600 lbs., was as follows:

Forms—labor and material.....	\$19.00
Concrete—labor and material.....	26.50
Reinforcement—labor and material.....	32.00
Total per pole.....	\$77.50

The above does not include cost of preparing site, engineering, etc., and is for the bare poles without fittings or foundation timbers. To obtain the cost of the poles erected, there must be added the cost of loading, distribution, foundations and setting, cross-arms, and fittings, but these items were special to the particular location and would be of little use as a matter of general information. It might be stated, however, that the cost of handling and erecting these heavy poles was considerably more than would be the case for wooden poles; furthermore, care must be taken in loading and unloading them, and special appliances are required for their erection.

In the special case in question it was figured that the cost of the line erected complete was not greatly in excess of that of an equally stable wooden pole line, as, in order to meet such a condition, it would have been necessary to employ "H" frame poles and set them in equally expensive foundation pits. In the case of this line it is interesting to note that the foundations and setting cost considerably more than the poles themselves.

\*Abstract from a paper by George Gibbs, chief engineer electric traction, Long Island R. R., in *Portland Cement*, October, 1912.

# METHODS OF HANDLING LIGHT EARTHWORK.

Experience Gained in Moving 330,000 Cu. Yds. on 14 Miles of Line, Including Details of Force Employed and Cost of Work.

By H. C. LANDON,

General Manager, Watauga & Yadkin River Railroad Co., North Wilkesboro, N. C.

The equipment necessary to grade a railroad depends largely on its location with reference to connections with other roads, the characteristics of the profile and the yardage to be moved in the several cuts to make the fills. In the construction of the Watauga & Yadkin River Railroad, which is building from North Wilkesboro, N. C., westward toward Boone, the fills are generally light and the cuts are not very heavy, although there are some comparatively heavy side hill cuts with a large percentage of rock. The difficulty of moving steam shovels far into this country on account of the very poor roads and lack of bridges, eliminated them from consideration, and a study of the profile



Fig. 1—Appearance of Cut Before Explosion

therefore determined that the greater portion of the earth and rock must be moved with drag scrapers, wheel scrapers and explosives.

## SCRAPERS.

The drag scraper can be used for very short hauls, but it was soon found that wheelers should be used for hauls over 50 ft., except in special locations where it is desired to move earth quickly and the distance is very short. A motion study developed the fact that with drag scrapers the speed of the mules was not over 7,200 ft. per hour, with a haul of 150 ft. on account of the frequent stopping to load the drag, and with a scraper force of six teams and a plow team the cost was about \$0.20 per cu. yd. When the distance was not greater than 50 to 70 ft. the cost of moving by drag scrapers was not more than \$0.12 per cu. yd., and earth has been moved for about \$0.11 per cu. yd., where little or no plowing was necessary. Observations made on 110 ft. hauls with drag scrapers indicated that under the best conditions 25½ trips were made per hour, giving a speed of 5,600 ft. per hour and approximately 25 yds. per team at a cost of \$0.17 per cu. yd.

As a general proposition the drag scraper is expensive in moving earth and should not be considered. A few drags on the job, however, are valuable and convenient, especially, for special purposes. In one instance it was questionable whether it would not be cheaper to make a fill with drag scrapers from a borrow pit alongside and waste earth from a cut approximately 600 ft. away. It developed that the cost to make the

fill from the adjoining borrow pit was approximately \$0.12 per cu. yd., while the cost of hauling the material from the cut with wheelers was only \$0.14 per cu. yd. To waste the cut and make the fill with drag scrapers would have cost not less than \$0.24 per yd.

Observation of the wheeler forces showed that the speed of the wheelers with the above haul was about 133 ft. per min., or about 1.5 miles per hour. An average of 300 yds. per day was handled with this wheeler force of one foreman, nine wheelers, one plowman, one loader, one dumper, one snatch team and one four mule plow team, at a total cost of approximately \$34 per day. This force, therefore, handled 300 cu. yds. at an approximate cost of \$0.146 per yd., and the amount handled could probably be increased if some system of premiums were devised. The low cost per team is due to the fact that the company owns its own teams and that \$3 per day is considered a high price for teams in the locality in which this road is being constructed.

Careful observation showed that with a haul of 300 ft., nine wheelers averaged 55 cu. yd. per day per wheeler at a cost per cu. yd. very little above \$0.09. The material handled was river bottom material, which is easily plowed and not difficult to handle, or a side hill cut with a sub soil of a reddish clay not much more expensive to handle than river bottom soil. Thirteen wheelers with 800 ft. average haul handled 300 cu. yds. per day at a cost of \$0.168 per cu. yd. With this haul it was cheaper to move the material out of the cut into a fill than at-



Fig. 2—Cut Opened by Explosion.

tempt to make the fill from the side ditch alongside, provided it was necessary to waste the material in the cut.

The advantage of the wheeler is in its capacity. The drag scraper requires from eight to ten loads per yd., while a No. 2½ wheeler requires but little more than two loads. The average speed of the teams operating wheelers in general is about 1.5 to 1.9 miles per hour, and on long hauls where there is no delay in loading, teams will make an average speed of 2.3 miles. On December 31, 1912, observation was made of two wheeler forces, both handling stiff red clay on side hill work. In the first instance, the force consisting of one plow team, one snatch

team and six wheelers, with an average haul of 415 ft., made four trips in exactly 20 min., traveling through some mud, or at a speed of 9,960 ft., or 1.9 miles per hour. The second wheeler force using nine wheelers, one plow team, one snatch team and with an average haul of 510 ft. made seven trips in 47 min., equal to 1.7 miles per hour. Each wheeler in the first force should, therefore, make approximately 12 trips per hour, or 120 trips per day and handle nearly 60 yds. of material. In checking the record of one-half day this was approximately what the teams were doing. The longer haul should have been made with greater speed per hour, but the condition of the ground over which the material was deposited made the movement somewhat slower than that of the other force. Even at this rate the labor cost per cubic yard would not very much exceed \$0.10, and under these conditions each team would handle 89 loads per day, or nearly 44 yds. per team.

With good teams and careful arrangement of the work the cost of wheeler work, even with hauls of 600 or 800 ft., can be kept down to a moderate price, provided the material is earth and can be plowed without much difficulty. The handling of material with drag scrapers where there is much rock is not very successful, although cuts have been handled successfully where material had to be blasted.

#### DUMP CARS.

Four small dump cars of 2 yds. capacity were used in the work. As it was difficult to get light steel rails, wooden rails made of 4 in. x 4 in. timbers were provided. These cars were used to move rock at a tunnel approach and in short cuts where most of the material was rock, which was required for the fills. The cars were loaded by hand and the hauls averaged about 250 ft. The cost per cubic yard with this haul did not exceed \$0.17. Where the haul was over 100 ft. the average gang loading cars, including drillers, was 14 men. This force would move about 150 yds., largely rock, at a cost of about \$25.

Dump carts for short hauls, of approximately 100 cu. ft. capacity, have proved very convenient for disposing of earth, where the haul was short and speed was not a requirement. The average gang employed loading carts was about ten men, and such a gang would handle 75 cu. yds. per day at a cost of approximately \$19.50.

#### POWDER AND EXPLOSIVES.

The location of the line being largely on side hills and in places where there was little or no danger in moving earth and rock with powder, it was decided to move a large portion of the side hill cuts by this means. Up to this date approximately 5,000 kegs of powder have been used, moving approximately 50,000 cu. yds. At first it was difficult to get the foremen to use the powder, but we finally succeeded in arranging the work so that the entire section lying between the small runs on the hillside was drilled with the proper number of holes; about on the center line, if in soft rock, or near the ditch line, if in hard rock, and from 10 to 17 ft. apart, depending upon the depth of the cut. These side hill sections were usually from 300 to 400 ft. in length, requiring from 30 to 40 holes. A No. 3 blasting machine was ordinarily ample to handle the shots. The first order of powder was for only 400 kegs, which was used in small units, but to very good advantage, moving approximately one yard of rock to every 2 lbs. of powder used.

One 80 ft. cut offered a serious problem. After a study of the situation it was decided that it might be possible to construct powder tunnels and blow off the top of the hill, thereby making an open cut. The line crossed a narrow ridge on a sharp skew which would enable the powder if properly used to throw the material away from the line. The first attempt was made at the west end of the cut, tunnels being driven at right angles to the line to the ditch line, and then both ways on the ditch line approximately 25 ft. above grade. It was supposed that a thorough study had been made of the material, which was generally stiff hard clay or rotten rock, but it developed that a very hard rock existed on the west end of the tunnel

parallel to the line. This disturbed the calculations somewhat. Only 400 kegs of powder were used to make the blast, the powder being placed in paper flour sacks and loaded in a compact manner in the tunnel, approximately filling it, the tunnel being 4 ft. wide and 5½ ft. high. Electric exploders attached to five or six sticks of dynamite were placed in the tunnel at intervals of approximately 25 ft. on the connecting wire lines. The end of the tunnel was tamped very thoroughly. The explosion which followed moved a large amount of earth, and earth which would have had to be removed finally to get to the mouth of a tunnel, which is now being constructed. However, while about 8,000 cu. yds. of material was moved the blast did not do the work expected. The hard rock west of the main tunnel proved of such great resistance that scarcely any material was moved at the summit of the cut, indicating that not enough powder had been used at any point in the tunnel and that the powder tunnels were not properly loaded to move the earth above and beyond the tunnels. The tunnel at the east end was then more carefully planned. Small tunnels were extended out 25 ft. at right angles to the main bore so as to reach approximately the north ditch line. The powder tunnel indicated that most of the material was rotten granite rock, not very difficult to move. It was estimated that about 15,000 yds. were to be moved and it was decided to use only 20,000 lbs. of powder. This powder was loaded in the tunnel in paper sacks as in the previous case. The exploders and the line were placed in the tunnel at approximately the same intervals as in the first instance and were all carefully tested. The total length of this tunnel was 245 ft., the powder filling all but 30 ft. of it. This blast moved approximately 14,000 yds. of earth. Two of the photographs show the west end of the tunnel before and after the shot.

Several other large blasts have been successfully made along the route in side hill cuts on different sections of the line, moving almost one-half yard of material for every pound of powder used. In one cut, estimated at 8,000 yds., 95 per cent. of which was solid rock, 33 holes were driven in two rows, the upper row being approximately 20 ft. deep and extending 2 ft. below grade, while the lower holes were 16 ft. deep, extending 6 ft. below grade. The holes were expanded twice; first by using five or six sticks of dynamite, and then by using 25 or 30 sticks. This material was all rock, and the second expansion of the holes was necessary, although it is believed that one expansion of the holes, using 10 or 12 sticks of dynamite would have given better results, as the second expansion tended to fill the holes rather than open them up to sufficient size. An average of 11 kegs of powder was used in expanding the upper holes and 13 in the lower holes. The results of this blast were very satisfactory, 378 kegs of powder being used, moving fully 7,000 cu. yds. of rock. A No. 3 push down battery was used in this explosion, although this was overloading the battery slightly.

In all the smaller shots that are being made, the foremen are instructed to use powder judiciously, and they are getting good results with a minimum amount of powder. The holes are made on the center line to a point about 2 ft. below the grade line and are spaced a distance apart equal to the depth of the holes. It is found that the holes drilled on the center line and to this depth below the grade will ordinarily pull down the grade about the amount desired, and will not move the earth too far back of the slope line where soft rock is handled. In some locations where we have encountered a very hard granite the upper holes are placed on the ditch line. Steam drills are used with hard rock, while a large percentage of the other holes are put down by hand and churn drills.

The total yardage in grading 14 miles of the road is 330,000 cu. yds., 20 per cent. of which is rock. This was moved with an average of 72 teams, 200 men, 150,000 lbs. of powder and ten tons of dynamite in less than six months. The average labor cost of moving earth was \$0.15, and rock at \$0.36. The wages paid for common labor were \$1.40 per day, pole drillers \$1.60, and hired teams \$3 per day.

## THE OIL ENGINE IN RAILWAY WATER SERVICE.

By C. R. KNOWLES,

General Foreman Waterworks, Illinois Central, Chicago.

Internal combustion engines using gasolene as a fuel have been used by railway water service departments for a good many years with varying success, depending largely on the care and attention given the engines. The advantages claimed for an engine of this type over one driven by steam are: Lower first cost; less floor space required; can be started more quickly than by firing up a boiler; economy in handling of fuel; proper installation presents a better fire risk; requires less attention. The latter feature is the principal claim to economy in a gasolene engine as by eliminating the services of a regular pumper, and giving the operation of the engine over to some employee in connection with other duties, the charge for attendance is only nominal and the cost of operation is reduced.

The possibility of operating a gasolene engine with little or no attention has caused many users to believe that such engines can be run without any attention whatever, except that required to start. Consequently the operation of the engines in many instances has been turned over to men wholly incapable of properly handling any machinery, and possessing no qualification except that of being conveniently located. The result has been a high cost for repairs and frequent delays and interruption to service, which destroy the saving that should be expected. The increasing cost of gasolene has cut down this margin of saving until it has become necessary to look for some other fuel as a substitute, and this problem seems to have been partially solved by the use of low grade oils, such as kerosene and power distillates. The necessity for using such oils has resulted in great activity on the part of the builders of oil engines and in the designing of attachments to permit the burning of low grade oils in gasolene engines.

In the course of development of the oil engine widely different types were evolved. In one type, known as the Diesel, the oil is injected into the cylinder by an enormous air pressure, and the heat raised by compression is sufficient to burn the oil instantly as it enters the cylinder. The types which we have to deal with, however, may be divided into two general classes, first a modified form of the above engine which may be known as a two-cycle valveless injection engine in which the compression has been reduced, adding the required temperature in a heated combustion chamber.

The engine is governed by throttling the oil supply and ignition is accomplished by the hot tube method, a common form being by means of a hollow hot ball. This hot ball is heated by a blow torch before starting, and after the engine is running the heat is maintained by the successive explosions of the engine. The cycle of operation is as follows: The air is drawn into the crank case by the up stroke of the piston through a port located just below the exhaust port, and is compressed slightly on the downward stroke of the piston. During the latter part of this stroke the inlet port of the cylinder from the crank case is open and the air is forced into the cylinder against a baffle plate on top of the piston which directs it to the upper part of the explosion chamber, partially scavenging the cylinder of dead gases. On the up stroke the piston compresses the confined air into the explosion chamber and ignitor ball, and at the same time an oil spray is discharged into the cylinder at high pressure by the oil pump. The temperature of this mixture of air and oil is raised by the heat generated by compression, assisted by the heat given off by the walls of the cylinder and head, ignition is caused by the ignitor ball, the explosion occurs, and the piston is forced downward on the power stroke. This operation is repeated at every revolution of the engine.

Engines of this type which inject liquid oil into the cylinder

are liable to carbon trouble and resultant deterioration, due to the fact that an excess of oil injected into the cylinder breaks up into volatile compounds, such as the naphthas, heavy tar-like oils, and free carbon. Improper lubrication also will cause carbon trouble. The high speeds and temperature at which oil engines work necessitate a continuous and skillful use of good oil. A great deal depends upon the proper lubrication of an engine of this type and the prevention of carbon forming in the cylinder. The destruction of the lubricating oil by combustion cannot be prevented and just what occurs to the oil in an internal combustion engine cannot be entirely explained, but there is no doubt that a great deal of it is burned along with the fuel oil, and as long as this is true it is necessary that complete combustion take place in order to prevent the residue of unburnt oil being left in the cylinder in the form of carbon. The greater the amount of carbon in the oil the greater the amount of air necessary to form complete combustion.

The lubrication of a steam engine or pump is comparatively simple. In steam engines there is generally a certain amount of water, but the flames of an oil engine dry the internal surfaces and unless the proper amount of oil is applied the cylinder, piston, and rings soon begin to suffer. In a steam engine or pump the temperature will reach at the most about 500 deg., while in an oil engine it rises as high as 2,500 deg. Added to this is the fact that the piston speed of an internal combustion engine is from three to four times that of a steam engine or pump, and consequently the oil engine requires a different method of lubrication and a great deal more of it. Another cause of carbon formation is an overload. When the engine is working up to its maximum power a momentary overload will cause an excess of oil and resultant accumulation of carbon due to the fact that the oil engine is not flexible enough to adjust itself instantly to the varying loads as is a steam engine or pump.

Another common type of engine burning the low grade oils operates on the well known four-cycle principle, consisting of four strokes of the piston or two revolutions of the crank. During the first outward stroke, which is called the suction stroke, the air is sucked into the cylinder and fuel is either pulled in with air or in some types injected by a pump, as with the two-cycle above described. This is followed by the return or compression stroke during which the piston compresses the charge. Ignition is accomplished by electric spark or by hot surface forcing the piston on its second outward or working stroke. The cycle is completed by the second return stroke of the piston, called the exhaust or scavenging stroke, during which the burnt gases are expelled from the cylinder through the exhaust valve.

Gasolene engines now in service are being converted into oil burning engines by the addition of attachments for pre-heating the oil to the flashing point before the oil enters the cylinder. These attachments consist of generators, or mixing chambers, where the oil is heated by the exhaust of the engine, and are made in various sizes and types both for throttling and hit-and-miss governors. With these attachments the engine is generally started on gasolene and allowed to run until the cylinder and generator are heated, when the oil is cut in. On other types a retort is provided where the oil is converted into a vapor or gas by heating the retort with a blow torch. Either method requires from five to ten minutes to start the engine running on oil. Very little carbon trouble is experienced with the use of these attachments and the lubrication required is about the same as with a gasolene engine.

A series of tests was made pumping from an 8 in. well 190 ft. deep, lifting water against 15 in. of vacuum, the total head being 61 ft., with an 8 in. x 10 in. single cylinder direct acting pump direct-connected to a 6 h. p. four-cycle horizontal gasolene engine equipped to run on kerosene and distillates as well

as gasolene. The engine was controlled by a throttling governor.

The fuels used were:

	Specific Gravity.	Flash.	Burn.
Distillate	40 deg. Baume	150 deg.	170 deg.
Methyl alcohol	40.5 deg. Baume	Same temperature	
Kerosene	46 deg. Baume	124 deg.	145 deg.
Gasolene	62 deg. Baume	Same temperature	
Motor spirits	58 deg. Baume	Same temperature	

EFFICIENCY TESTS.

	Distillate.	Alcohol.	Kerosene.	Gasolene.	Motor Spirits.
Lbs. fuel per hour	5.145	6.062	4.943	5.373	4.755
Cost fuel per hour, cents	.0347	.35	.06	.1313	.0975
Pump, r. p. m.	43.36	43.32	43.54	43.72	43.79
Pumped, g. p. m.	175.0	177.8	176.8	176.8	178.1
Water, horse power	2.69	2.73	2.72	2.72	2.74
Lbs. fuel per h. p. h.	1.91	2.22	1.91	1.97	1.74
Cost fuel per h. p. h., cents	.0129	.1282	.0220	.0483	.0356
Cost fuel per gal., cents	.04625	.40	.08	.15	.13
Pints per hour	6	7	6	7	6
Temperature cyl. start	165 deg.	90 deg.	135 deg.	46 deg.	46 deg.
Temperature cyl. running	145 deg.	145 deg.	145 deg.	130 deg.	125 deg.
Temperature inlet air	110 deg.	125 deg.	120 deg.	60 deg.	60 deg.

As will be seen from the above figures the distillate is the most economical of the fuels used, the cost per water horse power hour being 53 per cent. of the cost of pumping with kerosene, and only 27 per cent. of the cost of pumping with gasolene. This engine has been successfully operated on distillates from 36 deg. to 42 deg. Baume for a period of three years. The high cost of alcohol eliminates it as a fuel for pumping water and the results of this test are submitted merely for comparison. No doubt better results could have been obtained by reducing the area of the combustion chamber, as more compression is required to secure economical results with alcohol in internal combustion engines. The results obtained from the use of kerosene were practically the same as from the distillate, the only difference being in the price of the two fuels. The gasolene test shows such results as might be obtained from the average gasolene engine under the same conditions. The fuel known as motor spirits, recently produced as a substitute for gasolene, operates under the same conditions as gasolene. The only objectionable feature about this oil is a disagreeable odor which would perhaps make it undesirable in certain localities.

A 12 h. p. four-cycle gasolene engine with hit-and-miss governor pulling a 7½ x 24 in. working barrel in a deep well was equipped with a generator for burning low grade oils. Comparative tests showed that the engine consumed the same amount of 39 deg. distillate per h. p. h. as gasolene, the difference in cost of the fuels showing a saving of .0434 cents per h. p. h. in favor of the distillate. The cost of pumping water at this point is comparatively high, due to the fact that the water is pumped with a single-acting deep well cylinder which is not as economical as pumping with a surface pump.

The tabulated results of this test follow:

	Gasolene.	Distillate.
Lbs. fuel per hour	11.746	12.005
Cost fuel per hour, cents	21.875	8.093
Pump, r. p. m.	24	24
Pumped, g. p. m.	124	124
Water h. p.	3.4	3.4
Lbs. fuel per h. p. h.	3.458	3.53
Cost fuel per h. p. h., cents	.0643	.0209
Cost fuel per gal., cents	.125	.04625
Pints per hour	14	14
Cost per 1,000 gals. water, cents	.029	.0108

A test was conducted for a period of 30 days on two 20 h. p. vertical, two-cycle three-port valveless engines, direct-connected with clutch to a 9 in. x 10 in. single-acting triplex pump. During the test the engines were run alternately, one pumping days and one nights, each engine running an average of 10 hours out of 24. No effort was made to prime the test, the object being merely to show the actual figures under average working conditions.

A total of 10,684,452 gal. of water was pumped against a head of 69 ft. at a cost of \$50.20 for oil and lubricants. The fuel used was 39 deg. Baume power distillate, flash 126, fire 160, cost per gallon in tank car lots \$.04625. The engines ran smoothly and maintained practically a constant speed, the variations in speed from readings taken from time to time during the

test being from 398 to 403 r. p. m. No repairs of any kind were necessary and the formation of carbon in cylinders was not noticeable. However, the two mufflers showed a deposit of several pounds of dry carbon.

The tabulated results of the test follow:

Duration of test	30 days
Total number of hours	609
Amount of distillate used	803 gals.
Cylinder lubricating oil	46 gals.
Other lubricating oil	3 gals.
Kerosene	31 gals.
Speed of engine	400 r. p. m.
H. p. developed	6.76
Actual water pumped	10,684,452 gals.
Total head	69 ft.
Total gallons delivered per minute	292.5
Actual water horse power	5.07
Total actual h. p. h.	3,087
Pounds of oil per h. p. h.	1.025
Cost oil and lubricants per h. p. h.	.00857
Cost of fuel oil per h. p. h.	.006
Cost fuel oil per 1,000 gals.	.0034
Cost fuel oil and lubricants per 1,000 gals.	.0047

The results given above are not to be considered the best obtainable from the use of oil in pumping water, but represent the cost at the average pumping station. The use of low grade oils has proved to be practical and economical beyond all question. There are conditions where this type of pumping unit would not be satisfactory, particularly where a varying load is encountered. But where conditions are favorable, as in tank service, and the installation is ample in power, excellent results may be obtained, always provided the proper care is given the installation.

PROGRAM OF THE ROADMASTERS' ASSOCIATION CONVENTION.

The following program of business and entertainment has been prepared for the thirty-first annual convention of the Roadmasters' and Maintenance of Way Association, which is to be held in the Auditorium Hotel, Chicago, September 9-13.

TUESDAY, SEPTEMBER 9.

Morning.—Convention called to order at 10 a. m. by President William Shea.

Address of welcome on behalf of the city of Chicago by Mayor Carter H. Harrison.

Address of welcome on behalf of the railroads entering Chicago by W. H. Penfield, assistant chief engineer, Chicago, Milwaukee & St. Paul.

Reading of committee reports and general discussion.

Afternoon.—Reading of committee reports and general discussion.

WEDNESDAY, SEPTEMBER 10.

Morning.—Reading of committee reports and general discussion.

Afternoon.—Reading of committee reports and general discussion.

Automobile ride through the parks and boulevards of Chicago for the visiting ladies.

Evening.—Boat ride on steamer United States, leaving Clark street bridge at 6 p. m. Dinner will be served on board and there will be music for dancing. For roadmasters and guests and members of the Track Supply Association.

THURSDAY, SEPTEMBER 11.

Morning.—Election of officers.

Reading of committee reports and general discussion.

Adjourn at 1:30 p. m.

Afternoon.—Baseball game at 3:30 p. m., National League. Chicago vs. Brooklyn. For roadmasters, and guests and members of the Track Supply Association.

Evening.—Theatre party for visiting ladies.

Second annual banquet given by the Track Supply Association in honor of the members and guests of the Roadmasters' and Maintenance of Way Association. The banquet will be given in

the Auditorium. The list of speakers will include: H. R. Saford, chief engineer, Grand Trunk; W. L. Park, vice-president, Illinois Central; W. A. Garrett, vice-president, Chicago Great Western; Paul Hamilton, engineer track and roadway, Cleveland, Cincinnati, Chicago & St. Louis; James Burke, superintendent roadway, B. & B., Erie, and C. E. Lindsay, division engineer, New York Central. Goldsmith's orchestra and the Oxford Quartette will furnish entertainment during the banquet.

FRIDAY, SEPTEMBER 12.

Morning.—Reading of committee reports and general discussion.

Afternoon.—Reading of committee reports and general discussion.

The following committee reports will be discussed: "Contracting of Maintenance Work," "New and Improved Appliances," "Combined Organization of Maintenance Forces," "The Use of Power Driven and Labor Saving Appliances" and "Prevention of Accidents, Personal and Otherwise, Viewed from the Maintenance Standpoint."

In connection with the convention, the Track Supply Associa-

### SPECIFICATIONS FOR MANGANESE STEEL RAILS.

Although manganese steel rails have been manufactured for five years or more, it is only within the last two or three years that they have been made commercially, those rolled during the first years being largely for experimental purposes. During the past two years manganese steel rails have been inserted on curves near the entrance of the new terminal of the Chicago & North Western at Chicago; the Lackawanna has placed 500 tons on curves carrying a heavy freight traffic and they have been installed in a number of other roads as well as on elevated roads and in subways. Because of the attention being given to manganese rail at the present time, the following specifications of the Manganese Steel Rail Co., New York, are of interest:

1. Chemical composition.—For all sections:

Carbon .....	0.95 to 1.35 per cent.
Phosphorus .....	Not over .10 per cent.
Manganese .....	10.50 to 15.00 per cent.

2. Quenching.—All rails shall be quenched in water bath within a period of a minute and twenty seconds after leaving the final pass. In case, on any occasion, this limit of time before quenching

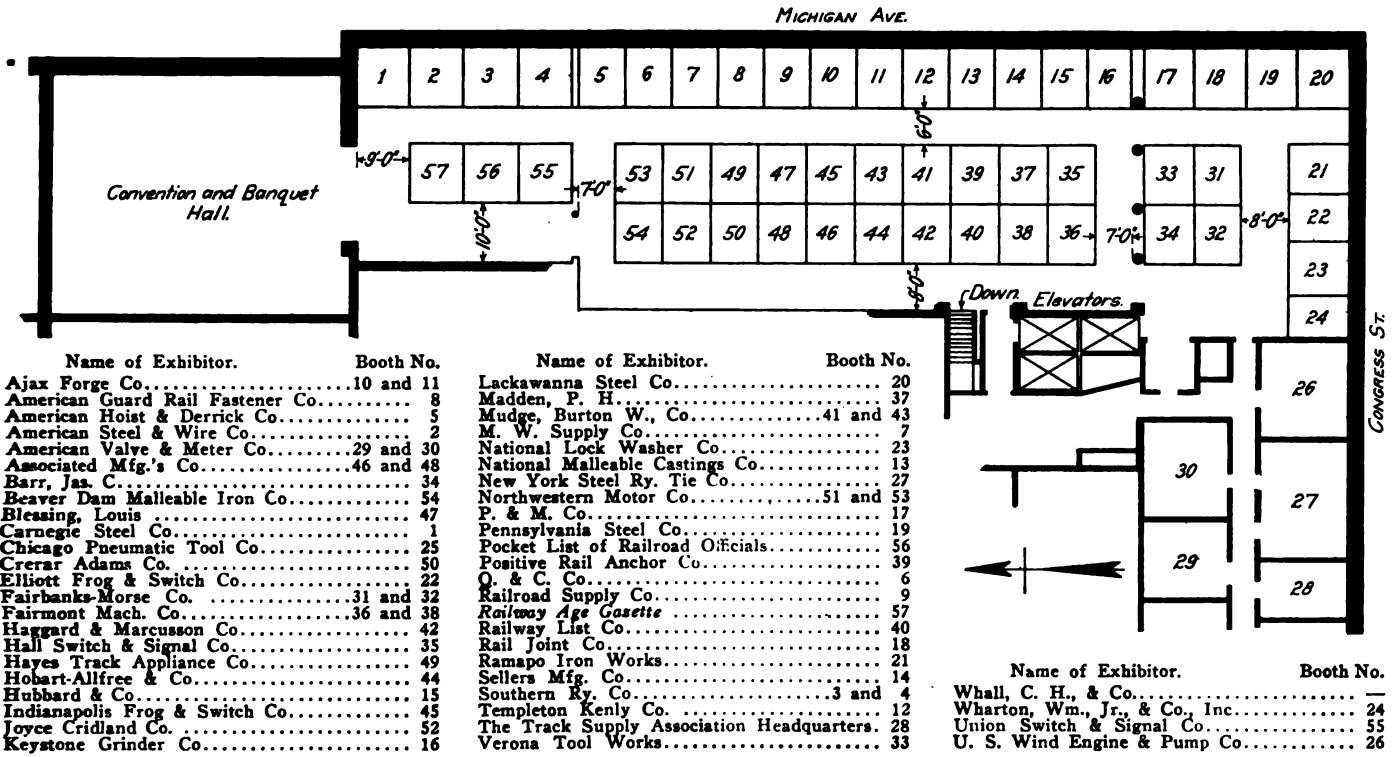

Plan of Track Exhibit at Roadmasters' Convention.

tion will conduct an exhibition of track material and devices in the corridors on the ninth floor of the Auditorium Hotel adjoining the convention hall. The location and number of these exhibits is shown on the accompanying diagram.

**FRENCH RAILWAY IMPORTS.**—The question of the origin of light railway rolling stock and material came up for discussion in the French senate a short time ago. The Minister of Public Works was asked whether the supply of this plant was reserved to French makers, and whether he would arrange for such a policy to be followed if that were not the case at present. Judging by the reply, French makers have nothing to fear in the matter. The minister said that he would not personally sanction an order going abroad unless there was a difference of at least 15 per cent. between the lowest French and the lowest foreign tender. This really means that the home makers have a protective tariff of thirty per cent., since there is an ad valorem duty of fifteen per cent. on imported material of the kind into France.

is exceeded, for any cause whatsoever, such rails shall be especially marked, and a bend test made from both ends of the bar. This bend test shall consist of taking a two-inch section of the finished rail and bending the head down towards the base, cold, under the steam hammer. In case this bend test from either end of the rail breaks, before the head has been bent through an angle of 90 deg., a further bend test shall be cut from the same end of the same rail and retested. If this retest breaks, the rail shall be retreated so as to stand all test specified herein.

3. Drop test.—The drop test shall be made on a piece of rail not less than four feet and not more than six feet long. These drop test pieces shall be selected, one from each pit in which the ingots are heated. These rails shall be placed head upward on the supports and the various sections shall be subjected to the following impact tests under a free falling weight:

Weight of rail per yard.....	Height of drop in feet.....
50 to 60 lbs.....	17
61 to 70 lbs.....	18
71 to 80 lbs.....	18
81 to 90 lbs.....	19
91 to 100 lbs.....	20

If any rail breaks when subjected to less than three blows under the drop, two additional tests shall be made on the "A" rails from the same pit; if either of these retests fails all of the "A" rails from the pit which they represent shall be rejected. Two tests shall then be cut from the "B" rails from the same pit and if both of these tests meet the above requirements, all the remaining rails from that pit shall be accepted. If either of these "B" rails fails all the "B" rails from that pit shall be rejected. Then two tests shall be cut from the "C" rails and tested, and so on until all the rails from the pit have been tested.

The drop testing machine shall have a tup of 2,000 lbs. weight the striking face of which shall have a radius of not more than 5 in., and the test rails shall be placed head upwards on solid supports 3 ft. apart. The anvil block shall weight at least 20,000 lbs. and the supports shall be part of, or firmly secured to, the anvil. The report of the drop test shall state the atmospheric temperature at the time the test was made. The temperature of the test pieces, when tested, shall not be less than 60 deg. F., nor greater than 120 deg. F.

4. Section.—The section of the rail shall conform as accurately as possible to the templet furnished by the railroad company, consistent with clause No. 5 relative to the specified weight. An allowance in height of 1/64 in. under and 1/32 in. over and in width of 1/16 in. will be permitted. A perfect fit of the splice bars shall be maintained.

5. Weight.—The weight of the rails shall be maintained as nearly as possible, after complying with clause No. 4, to that specified in contract. Rails shall be accepted and paid for according to actual weights.

6. Length.—The standard length of rails shall be 30 or 32 ft. Ten per cent. of the entire order shall be accepted in shorter lengths, varying by even feet down to 24 feet. A variation of 1/4 in. in length from that specified will be allowed.

7. Branding.—The name of the maker, the weight of the rail and the month and year of manufacture shall be rolled in raised letters on the side of the web, and the number of the heat and the number of the pit in which the rails were heated shall be so stamped on each rail as not to be covered by the splice bars. A letter shall be stamped on the side of the web to indicate the portion of the ingot from which the rail was rolled.

8. Punching.—Circular holes for splice bars shall be punched in accordance with the specifications of purchaser. They shall in every respect accurately conform to drawing and dimensions furnished and shall be free from burrs.

9. Finishing.—The distance between the supports of rails in the gaging press shall not be less than 42 in. Rails shall be straight in line and surface when finished—the final straightening being done while cold—smooth on head, sawed square at ends, variations therefrom to be not more than 1/32 in., and prior to shipment shall have the burr caused by the saw cutting removed and the ends made clean.

10. Inspection.—The inspector representing the purchaser shall have free entry to the works of the manufacturer at all times while his contract is being executed, and shall have all reasonable facilities afforded him by the manufacturer to satisfy him that the rails are being made in accordance with the terms of the contract. All tests and inspections shall be made at the place of manufacture prior to shipment, and shall be so conducted as not to unnecessarily interfere with the operation of the mill. The manufacturer shall furnish the inspector with a complete analysis of every heat. Analyses shall be made on drillings taken from small test ingots, the drilling being taken at a distance of not less than 1/4 in. beneath the surface of said test ingot. On the request of the inspector, the manufacturer shall furnish drillings for check analysis.

11. No. 2 Rails.—Rails, which by reason of surface imperfections, are not classed as No. 1 rails, shall be considered No. 2 rails; but No. 2 rails shall not be accepted for shipment which have flaws in the head of more than 1/4 in., or in the flange of more than 1/2 in. in depth; and these shall not, in the judgment

of the inspector, be, in any individual rail, so numerous, or of such a character, as to render it unfit for No. 2 rail uses.

12. Designation of No. 2 Rails and Short Lengths of No. 1 Rails.—Both ends of all No. 2 rails shall be painted white. Both ends of all short length No. 1 rails shall be painted green.

## WHITEWASHING DEVICE WITH PORTABLE COMPRESSOR.

By F. W. BENTLEY, JR.,

Machinist, C. & N. W., Milwaukee, Wis.

The practical utility of compressed air for applying paints and washes by the spray method is unquestioned where the supply of air can be maintained in quantity of flow and pressure to suit the requirements of the spraying device. The most serious drawback in connection with using the above method for whitewashing mileboards, crossing-posts, etc., lies in the

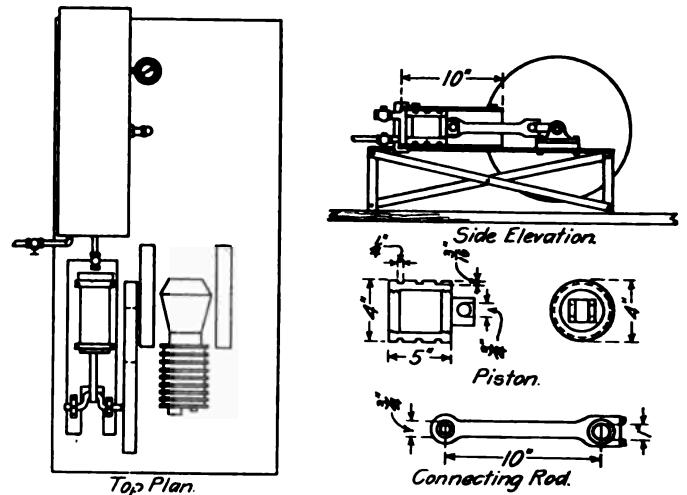

Details of Home-made Compressor.

difficulty of securing an efficient and inexpensive means for producing the compressed air.

The accompanying sketches and photographs illustrate a cheap, simple and efficient portable compressor, made out of odd fittings picked up in the shop and attached to a motor section car. The sketches were made by the writer from suggestions given for its construction by J. E. Tisdale, general foreman.

As the motor car to which the compressor is secured is self-propelling, the equipment is rapidly moved from one section to another with an attached trailer containing slacked lime solution.

The compressor cylinder is made from a piece of pipe bored to a diameter of 4 in. It is of the single stroke type having a



Compressor Plant on Motor Car for Spraying White Wash.

1/2 in. discharge and a 3/4 in. intake valve in the forged cap at the head end. The piston is made from an old rod bushing into each end of which old washout plugs are screwed three or four threads, giving the piston the advantage of lightness. The square head of the crank end plug was slotted out to take the rod pin of the back connection of the small 10 in. piston rod. A crank of 1 in. steel was forged with a 5 in. throw, being held in bearings as shown. An 18 in. pulley is placed on the other end of the shaft, being belted to a 6 in. pulley on the shaft of the car engine. The reservoir for storage is an old 14 in. x 33 in. drum taken from a scrapped engine, and is equipped with a gage and safety valve, which is set at 60 lbs.

With the above device it is possible to quickly raise and easily maintain any required pressure for operating the whitewash spray. The arrangement also greatly facilitates such work in-so-far as both labor and expense are concerned, for it is possible to simply turn it over to each consecutive section foreman as the work progresses.

### TWO METHODS OF CALCULATING FROG ANGLES.

By F. W. RIZER,

Assistant Engineer, Chicago, Burlington & Quincy, Chicago.

In frog and switch calculations, where it is the practice to carry out the angles to hundredths or thousandths of a second, some perplexity occurs where a person using one method attempts to check calculations in which the other method was used.

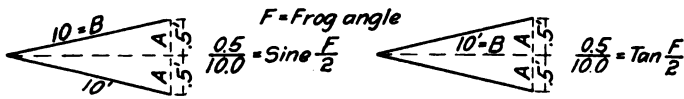

FIG. 1.

FIG. 2.

#### The Sine and Tangent Methods of Measuring Frog Angles.

Figs. 1 and 2 show the two methods of calculating the angle of a No. 10 frog. The sine is used in Fig. 1 and the tangent in Fig. 2. Both of the above methods are correct from a mathematical standpoint and either may be used provided one or the other is formally adopted as standard. Some railways and frog manufacturers use the former method and others the latter.

Most of the engineering field books, for some unknown reason, give the frog angles which are calculated as in Fig. 2, although that shown in Fig. 1 seems to be the more logical method since the definition of a 1 in 10 frog, for example, is a frog that spreads one foot in ten feet, and a person measuring a frog or laying out the angle will measure the distance along the rails and not on the line which bisects the angle.

Below is a table showing the frog angles, calculated by the two methods. The angles in the left hand column were calculated, as in Fig. 1, by the writer with a seven place table of functions and are correct to the nearest thousandth of a second. The angles in the right hand column were calculated as in Fig. 2 and are copied from Searles:

Spread of Frog.	$\frac{A}{B} = \text{Sine } \frac{F}{2}$	$\frac{A}{B} = \text{Tan. } \frac{F}{2}$
1 in 4	14 deg. 21 min. 41.436 sec.	14 deg. 15 min. 00 sec.
1 in 5	11 deg. 28 min. 42.024 sec.	11 deg. 25 min. 16 sec.
1 in 6	9 deg. 33 min. 37.378 sec.	9 deg. 31 min. 39 sec.
1 in 7	8 deg. 11 min. 31.520 sec.	8 deg. 10 min. 16 sec.
1 in 8	7 deg. 09 min. 59.916 sec.	7 deg. 09 min. 10 sec.
1 in 9	6 deg. 22 min. 10.121 sec.	6 deg. 21 min. 35 sec.
1 in 10	5 deg. 43 min. 55.084 sec.	5 deg. 43 min. 29 sec.
1 in 11	5 deg. 12 min. 37.809 sec.	5 deg. 12 min. 18 sec.
1 in 12	4 deg. 46 min. 33.714 sec.	4 deg. 46 min. 19 sec.
1 in 13	4 deg. 24 min. 30.435 sec.	
1 in 14	4 deg. 05 min. 36.336 sec.	
1 in 15	3 deg. 49 min. 13.534 sec.	
1 in 16	3 deg. 34 min. 53.649 sec.	
1 in 17	3 deg. 22 min. 14.974 sec.	
1 in 18	3 deg. 11 min. 00.630 sec.	
1 in 19	3 deg. 00 min. 57.295 sec.	
1 in 20	2 deg. 51 min. 54.314 sec.	

### TESTS OF A FIRE RESISTING PAINT.

The protection of timber bridges from fire has received increased attention during the past two or three years. Among the various means adopted to protect structures against fires, paints have been frequently used. A number of tests have been made recently of the Clapp Fire Resisting paint, made by the

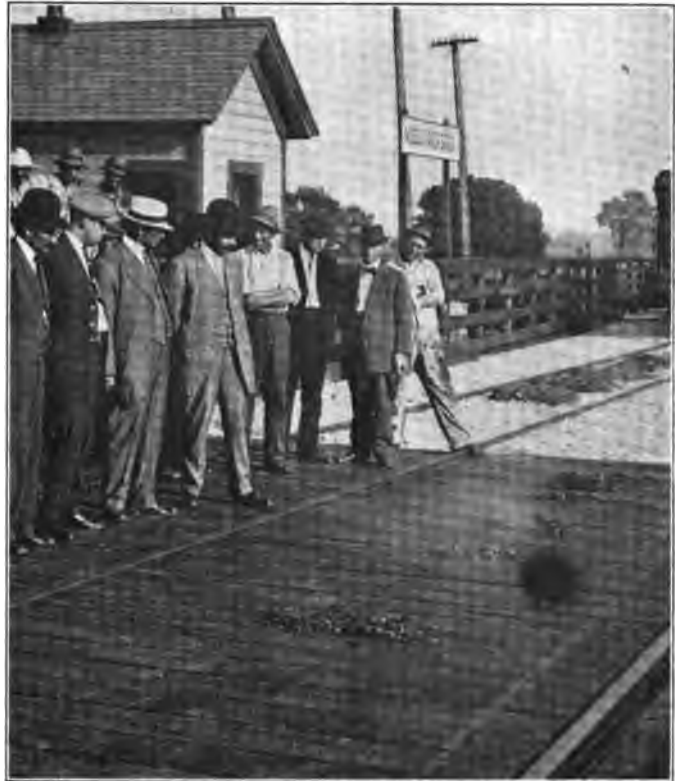

Burning Coals on Missouri River Bridge of the Illinois Central.

Clapp Fire Resisting Paint Company of Brookport, Conn., and as a result of these tests a number of roads are using this material regularly as a protection against fire.

On September 3, 1912, this paint was tested on the Missouri river bridge of the Illinois Central at Council Bluffs, Iowa. The floor of this bridge consists of a 3 in. plank deck on which one coat of this paint had been applied. The paint was put on at a boiling temperature so that it would penetrate the wood



Result of Test on Missouri River Bridge, Showing Slight Charring of Wood.



quickly. After an interval of four weeks it was tested by placing live coals at five different places on the deck. These coals were taken from the firebox of a locomotive in a blazing condition and burned one hour and 10 min. before going out. After they went out an examination showed that the planking was only charred to a depth of  $1\frac{3}{8}$  in. and the fire had not spread from the original areas covered.

On the following day a test was made of a one span structure erected purposely for this test at Chicago. One coat of



Attempting to Burn a Section of Test Trestle at Chicago.

paint had been applied to this structure about three weeks previous to the test. Six large sacks of shavings, three bales of hay and one bale of straw were scattered under the structure and it was fired. After the fire was completely out an examination showed that the timbers were charred but very little. Although the stringers, ties and bents were a solid mass of flames shortly after the fire started, as soon as the paint began to come out of the wood it formed a hard crust which soon extinguished them.



Effect of Fire on Test Trestle at Chicago; Surface Charred Only.

The Chicago Great Western tested the Clapp paint in July, 1911. Pile trestle bridge No. 341 near Stillman Valley, Ill, had been painted with this preparation, one gallon covering about 150 sq. ft. of surface. An engine was run across the trestle, which is 147 ft. long, dumping as many live coals as possible. There was no indication of fire starting. The engine was run across several times with the same result; then several shovels of burning coal were deposited on the ties and between the ties on top of the stringers. This coal was permitted to burn until the fire went out, no water being used to extinguish the fire, with the result that in each case a spot about 4 in. in diameter was charred to a depth of  $\frac{1}{2}$  in. to  $\frac{3}{4}$  in. There was no indication, however, of the fire spreading. One of the coals dropped from the engine fell in a little pocket in one of the ties, which had probably been caused by a knot falling out. As this pocket had been well coated with paint the fire was immediately extinguished.

In addition to the fire resisting qualities of the paint, it was found in this case that it also acted to some degree as a preservative. The trestle on which the test was made was built in March, 1904, and it was expected to replace it during the present season. When an inspection was made of its condition early this spring it was found that it would be possible to let the old structure remain for at least one more year. The Clapp paint is standard for certain classes of structures on the Chicago Great Western, and a stock is kept in the store department for distribution as needed.

### A TRACK SHIFTER.

When excavation is being carried on parallel to a track which is being used for construction purposes, the track must be shifted laterally from time to time, as the cut approaches it, and it is convenient to have some means of doing this work systematically and cheaply. The usual method of using "main force and crowbars," is expensive and slow.

A device intended to shift track easily and cheaply has been developed by the Maschinenfabrik Buckau of Magdeburg, Ger-



Track Shifters in Operation.

many. The machine which is shown in the illustration simultaneously raises the rails and shifts them laterally about 24 in.

A chain is passed under the rail and hooked to the device, and one man at each apparatus can do the entire work of shifting. The device weighs 280 lbs. The amount of lift and shift depends on the slope of the grounds, the arrangement of the chains, etc. The time required depends on the strength and skill of the men.

**THE KILBOURNE & JACOBS AUTOMATIC AIR DUMP CAR.**

A new side dump car which is unlocked, dumped, righted and relocked automatically by the application of air drawn from the air brake train line has been developed by the Kilbourne & Jacobs Manufacturing Co., Columbus, O. This car is dumped by a piston on one side and is righted by another piston on the opposite side, the operating devices for each side being

load of 23 cu. yds. The third car, the 16 yd. "Range" type is designed for heavy service, especially in handling iron ore strippings.

These cars have been used on a number of systems including the Chicago, Burlington & Quincy, Chicago, Rock Island & Pacific, Louisville & Nashville, Great Northern, Pennsylvania Lines and Delaware, Lackawanna & Western. They are being used not only for grading work but for ballast cars and for handling cinders. One southern road has adapted this type of equipment to the handling of sugar beets. In one instance 26 16 yd. cars of this type carried an average load of 98,000 lbs. for 11 hours per day for seven months, hauling in this period 4,500,000



Side View of Kilbourne & Jacobs Car.

entirely separate and independent. The storage reservoirs are placed between the draft sills and are charged directly from the air brake train line.

The cars are designed to dump upon the high side of a curve as well as upon the low side. Trains can be dumped simultaneously to the right or left; alternate cars can be dumped on opposite sides, or any portion of the train can be dumped independently. They dump at an angle of 44 deg., throwing the material clear of the track and thus largely eliminating danger of derailment. The unlocking and relocking of cars is automatic and being locked in transit they cannot dump accidentally.

The car is constructed of steel throughout with the exception of the floor which is of hardwood. The doors are of steel box girder type and are suspended at the top from the lifting levers so that they are free to swing out when struck by the dumping load. The car conforms to the specifications of the Master Car Builders' Association and the Interstate Commerce Commission and is designed for use in freight trains at all ordinary speeds.

This type of car is built in three sizes. The 20 yd. "Range" type is designed for work on the main line and weighs approximately 47,800 lbs. with a length over couplers of 32 ft. and with a maximum capacity of 28 cu. yds. The "Contractors" type is lighter in construction with 16 cu. yds. capacity and a maximum



End View of Steel Air Dump Car, Showing Hinged Doors, etc.

cu. yds. of iron ore. These cars worked in temperatures falling at times as low as 22 deg. below zero, and the total repair bill for this time was \$544.18, or \$20.93 per car.

**EXPERIMENTAL RAILROAD.**—The Railroad Company of this city (Raleigh, N. C.) expect to have their road between the Capitol Square and the Stone Quarry completed by New Year's Day if not prevented by inclement weather, and a handsome car upon it for the accommodation of such ladies and gentlemen as may desire to take the exercise of a railroad airing.—From a despatch dated December 28, 1832, to the American Railroad Journal.



Under-side of Dump Cars, Showing Air Cylinders and Operating Mechanism.

## UNIVERSITY OF CINCINNATI CO-OPERATIVE COURSE IN RAILWAY ENGINEERING.

The experiment of the University of Cincinnati in offering co-operative engineering courses received widespread attention at its inception and has been watched with interest by many educators and engineers. The possibility of training young men as railway engineers in a course which combines practical experience in various departments of railroad work and a thorough training in engineering principles is of particular interest to railway men. These courses have now been in existence long enough to indicate their success and to make a description of their operation interesting. The students in railway engineering

university. The students are divided into pairs, alternating at work and in school, the period of alternation being two weeks. This arrangement has been found best for the students, and since one of the boys is always at work, the employer receives continuous service. The co-operative courses are offered in chemical engineering, civil engineering, electrical engineering, mechanical engineering and metallurgical engineering, railway engineering being considered as one of the branches of civil engineering.

The electrical engineering and mechanical engineering students were first tried on the co-operative plan. The logical place to start such students in practical work seemed to be in a foundry. Here they cut sand, help the molders, and feed the cupola with the other foundrymen, being transferred after a time to the ma-



General Laboratories at the University of Cincinnati, the Only Shop in the Institution.

are now being used on three divisions of the Pennsylvania Lines West and the Cleveland, Cincinnati, Chicago & St. Louis is employing them in track, signal and bridge gangs with very good satisfaction. The first test of these boys in railroad work was made on the Union Pacific, the accompanying photograph showing some of them engaged in handling rail in an ordinary section gang. On account of the distance from Cincinnati, however, the Union Pacific had to discontinue the use of these students.

The co-operative courses are based on the principles that by giving students theory and practice alternately, they will derive the greatest good from both and that the experience gained in working under actual industrial conditions is much more valuable than that acquired in a "practice shop" maintained by a

chine shop and other departments of the plant where they work in much the same manner as an apprentice machinist, finally reaching the designing and engineering departments.

When the co-operative plan was extended to the civil engineering course, places could easily be found for the students in the city engineering department and with engineers and contractors on building and bridge construction. It was a much more difficult matter, however, to plan for a course of railroad work which would properly train a student to become a railway engineer. It was realized that positions on an engineering corps, which are usually the only ones open to engineering students or young graduates, do not give the boys the knowledge of maintenance and operation which a successful railway engineer needs, and it was therefore decided to start

them in an ordinary section gang. They are required to handle a pick and shovel at first, being given the same treatment and pay as other section hands. After a time, however, they get a chance to help make out the foreman's reports and may act as assistant foremen when they show the ability. From the section gang the boys go to a bridge carpenter gang, where they repair pile trestles, renew timber decks and handle minor repairs on buildings. Then they are placed in a signal construction gang where they may start by bonding rails or placing concrete foundations, being given a chance later to help install interlocking machines or maintain block signals. The length of time spent by a student in each of these three departments is approximately one year, although local conditions, the boy's previous experience and his rate of progress in the work may cause some changes in this schedule to be made.

As the railway course has only been operating for three years it cannot be said definitely what positions the boys will fill beyond those named. It is expected, however, to give them some knowledge of construction work, such as track elevation or yard construction, and some experience in the motive power department, probably at a division engine terminal where they can learn the general construction of cars and locomotives and acquire considerable operating knowledge. Arrangements have been made also to give them experience in a bridge shop, and



University of Cincinnati Co-operative Students In a Union Pacific Section Gang.

to place them with railroad contractors doing heavy construction.

One of the principal advantages of the co-operative system is that all practice shops can be eliminated from the university. At Cincinnati the only laboratory in the institution which in any way approaches the practice shops known in most engineering colleges is the general laboratory which is shown in one of the accompanying photographs. This is fitted up for testing work on all kinds of mechanical and electrical devices, and is used for some class work, and in large part for thesis work. Incidentally, the thesis work done by students in a co-operative course can be made much more valuable than the problems usually handled by senior engineering students. After working for five years in a shop or on a railroad, the student is more than likely to have come in touch with some definite problem which needs solution, and in several instances, manufacturers have co-operated with students in such thesis work by furnishing full sized machines and all equipment for the making of tests from which they were anxious to secure the benefits. The

fact that no practice shops are needed means that a very large saving in expenditure for equipment can be made, and this saving when applied to the salaries of professors makes it possible to get the best men available.

Another of the advantages of the system as it is operated at Cincinnati is that a very careful selection of students is made. The capacity of the school is limited and the 285 students who were taking these courses last year were all that could be handled under present arrangements. Out of the total number of applicants for entrance, of which there are several thousand each year, the number of new students that can be accommodated, which is now 160, are selected after careful questioning and after making sure that the applicant fully understands what he wants to study and what will be expected of him in the co-operative course. These boys are required to start their practical work in July, and their admission to the university in the fall is in a measure dependent on the showing made during the summer. Most of those who lack the qualities required to carry out so strenuous a course as this are eliminated before school opens in the fall. Further elimination is made during the first year and readjustment as to course is often found advisable. In most engineering schools any boy who presents credentials of scholarship from a recognized preparatory school is accepted as a student and is allowed to pursue the course which he thinks he wants to take. Under the system at Cincinnati the professors have an excellent chance to determine from the boy's work both in the shop and the classroom whether he is adapted to the line of work he has entered and if not, they urge him to change as soon as possible. This system of selection results in the securing of young men who are not only good students, but who have in large measure the natural qualifications to become engineers.

The fact that the students receive regular rates for the work done makes it possible for many boys to take this course who would be unable to secure the money for a regular four year theoretical course. The amount of money paid to the boys is usually not sufficient to pay all of their expenses of board, lodging and tuition, but some of them have even been able to save money during the five years they were in the university. A minimum rate of \$0.15 per hour for the first year, with an increase of \$0.01 per hour for each succeeding year is fixed by an agreement between the university and the various companies for which the boys are working. The minimum scale on the Pennsylvania and the Big Four, where most of the boys in railway engineering are taken, is \$0.165 per hour to start. The tuition is \$50 a year, with the usual laboratory fees and text book expense.

An important feature of the system is the use of special instructors called "co-ordinators," who spend enough time with the boys at their work to keep in close touch with the problems that they are meeting there so that these problems may be explained and used in classroom work to illustrate principles which are being taught, thus definitely connecting in the student's mind his practice and theory.

Probably the best indication of the success of the co-operative courses is the showing made by the students and the satisfaction which is shown by their employers. There is at present a much greater demand for the co-operative students by industrial firms in and around Cincinnati than the university's facilities can accommodate. Agreements have been made by the university with about 65 corporations to take co-operative students and other companies that are waiting for a chance to get young men of this kind may be added to this number if plans now under consideration for offering somewhat more specialized courses to train boys for executive positions in industries not generally recognized as of an engineering nature are carried out. The ability of the co-operative students to handle important work is shown by the fact that two of the boys during last summer alternated as foreman of an important department of a big machine shop to allow the regular foreman to go home to Belgium for a vacation.

Another example of their ability was shown just after the

floods of last spring when a call for assistance was sent in by the town of Hamilton, Ohio, which had been very seriously damaged. The dean of the engineering college took 12 senior electrical students to Hamilton without much knowledge of what was needed, but with the intention to do the best they could to relieve the situation. It was found that the water supply of the town was cut off since this water was secured from deep wells driven by electric pumps and the local generating station had been so flooded that the motors and switch-board equipment were too badly damaged to operate. The boys took hold of this damaged plant, and in less than a week had overhauled the water-soaked motors, repaired the switchboards and were supplying water to the town.

During the emergency work which had to be done by the C. C. C. & St. L. after the same floods, two of these co-operative students proved themselves very valuable members of emergency gangs. One of these boys had enough knowledge of electrical engineering to install a temporary lighting plant at the site of a big bridge which had been washed out, making it possible for the night shifts to work to much better advantage.

Dean Herman Schneider, of the school of engineering of the University of Cincinnati, is responsible for the adoption of this experiment, and he feels that the results secured have justified his contentions in favor of the system.

### MOTOR CAR TROUBLES, THEIR SYMPTOMS, CAUSES AND REMEDIES.

The Educational Bureau of the Union Pacific has recently issued a copyrighted instruction book on "Railroad Track Motor Cars," a copy of which has been supplied to practically every employee operating motor cars. The following notes are taken from this book:

A gasoline engine or a motor car usually behaves in one of the four following ways: It does not run at all. It runs nicely a short distance and then stops. It runs—explosions being quite regular, but the engine seems weak and does not develop power. It runs—explosions being irregular or infrequent; that is, the engine misses fire but apparently has plenty of power when explosions do occur.

Each of these symptoms indicates one or more specific causes as described in the following paragraphs:

If the motor car does not work, or does not operate properly, the trouble should be looked for and remedied as quickly as possible. If the operator does not know from the action of the engine the cause of the trouble, time may be saved by searching for it in a systematic manner. There may be no buzz at the vibrator; this may be due to one or more of the following causes: The battery switch may not be closed, or the throttle lever may not be in position to close the circuit. The primary wires may be loose at their connections. There may be a broken primary wire or a poor connection to the binding post between the battery and the spark coil; between the spark coil and the timer; or between the battery and the ground connection on the throttle-lever quadrant or the engine frame; or dirt may be interfering with the proper contact at the timer. If the primary wires are all right, then the vibrator spring may need adjusting or the contact points need cleaning. Adjustment of the spring can be accomplished by operating the thumb screw provided, and the contact points may be cleaned by passing a strip of paper between them while the vibrator is gently pressed down. If the vibrator will not operate after the above remedies have been applied, the indications are that the battery is too weak.

If there is a buzz but no explosion, some one or more of the following suggestions may aid in finding the cause: The cock in the gasoline pipe may be closed. Endeavor to get an explosion by priming the cylinder with a thimbleful of gasoline. If an explosion does not follow, a grounded secondary wire or a poor connection to the binding post between the spark coil and the spark plug should be looked for.

If the secondary wire is found in proper condition, the battery switch should be opened to prevent the operator from receiving a shock from the battery; and the spark plug should be removed by unscrewing. Then lay the spark plug on the cylinder head so that the rod in the center of the plug will not be in contact with the cylinder head; close the battery switch and push the car until a buzz is obtained at the spark coil. If under these conditions no spark is obtained at the spark plug, the insulated rod in its center should be cleaned; following which, if there is still no spark produced, the spark plug should be taken apart and cleaned, or a new spark plug should be substituted for the one removed.

#### RUNS FOR A SHORT DISTANCE.

If the car runs nicely for a short distance and then stops, the most frequent cause of trouble is interference with the proper supply of gasoline. The operator may have neglected to open the cock between the gasoline tank and the carbureter—the car stopping as soon as the limited supply of gasoline in the carbureter is used up. There may be dirt or an obstruction of some other kind in the gasoline pipe, which prevents the free flow of gasoline to the carbureter. There may be water in the gasoline, which is carried over from the carbureter and collects on the spark-plug points, forming a bridge through which the current can pass without creating the desired spark in the cylinder. The batteries may be weak, having only sufficient strength to supply current for a few explosions.

Weak explosions may be due to some one or more of the following causes: The fuel mixture may be too "rich." This will be indicated by smoke or yellow flame passing from the exhaust pipe or muffler. The needle valve should be closed tight, the throttle opened and the car pushed 200 or 300 feet to clear the cylinders of gas. Then the needle valve can be opened a part of a turn and another start made. The needle valve may have been opened too far before starting the engine. The fuel mixture may be too "weak." This will be indicated by the odor of the exhaust or by back-firing with a two-cycle engine. In such a case the needle valve should be opened a part of a turn or more. The muffler may be clogged, preventing free escape of all of the burned fuel. In such a case the muffler should be taken off and cleaned.

If there are few and irregular explosions, the trouble may be due to some of the following: The cylinder inlet valve may not work. The car should be pushed and the valve watched to see whether it is stuck; and if so, it should be opened several times by hand until it works properly. If only a few explosions occur after priming the cylinder the carbureter should be primed again and the needle valve opened part of a turn. The primary or secondary wires may be grounded on account of poor insulation, particularly the secondary wires, in which case there will be a continuous buzzing when the switch is closed, irrespective of the position of the timer. Investigate to see whether the secondary wires are securely tightened in the binding posts.

The needle valve may require opening a few turns on account of a partial clogging of the valve through an encrustation or deposit on the valve stem. Experiment by closing the needle valve and then fully opening it, because the passage way may be clogged with sediment from the gasoline. Sometimes if the car is pushed along the track about 100 feet the dirt will be sucked out of the needle valve. The suction should be tested by placing the hand over the air-intake opening of the carbureter while the car is moving. If this suction is found to be weak, the air-intake valve should be opened about three-quarters of the length of the screw, because the suction may be insufficient to pull the gasoline through the needle valve of the carbureter, and into the cylinder through the cylinder inlet valve. Weak suction may indicate that the intake valve is stuck shut, or that the exhaust valve is stuck open, or that the throttle valve of the carbureter may be partly or completely closed. If when the car is moved air is blown outward through the carbureter, instead of being sucked in, it indicates that the inlet valve is stuck open, or in case this valve is mechanically operated, it indicates that the cam

shaft or intake cam is out of position, resulting in the improper timing or opening of this valve. Inexperienced men driving cars that have chain-driven cam shafts have much trouble from cam shafts and cams being out of position.

Take off the top cover of the carbureter and see that the valve works freely, and whether gasoline runs freely into the cup when the float is depressed. Gasoline leaking from around the top of the carbureter (flooding) indicates dirt in the float valve, or that the float is stuck down. It is a common practice when it is thought that there is dirt in the needle valve to screw the valve tight and open it again. This practice almost always results in embedding hard foreign substances permanently in the nozzle. In Schebler carbureters it is better to take the top cover off the carbureter and insert a small common pin into the nozzle where it opens into the mixing chamber. This should be done before drawing off the gasoline as foreign substances will then be dislodged and can be drawn off by draining the carbureter. Try closing the cock in the pipe which leads from the gasoline tank to the carbureter. Then unscrew the plug at the bottom of the carbureter, drawing the gasoline into a cup. If there is any water or dirt in the float chamber of the carbureter or the gasoline pipe, it will be drawn off in this manner. The plug may then be replaced, the gasoline cock opened, and the carbureter primed for another trial. Finally, if only a few explosions occur after priming the cylinder and testing for the trouble in the foregoing manner, it is necessary to clean the needle valve of the carbureter. This may be done by closing the cock in the gasoline pipe, unscrewing the needle valve and very gently pushing a piece of wire into the needle-valve opening with such care as not to injure the nozzle. This will free the valve of any obstruction.

Misfiring is another cause of trouble, and may be due to one or more of the following conditions: The primary wire should be inspected to see whether it is broken or loose at any of its connections, because this will stop the buzz of the spark coil if the broken ends are separated or shaken apart due to the vibration of the car. The secondary wire should be inspected because it may have become loosened or grounded as a result of the vibration of the car. The buzzer of the spark coil may not be properly adjusted or it may be sticking either up or down so that the buzz is not continuous. In such a case the vibrator screw should be adjusted and the contact points cleaned. The timer contacts may be rough, or the stationary part of the timer may be loose. In such a case the contacts may be smoothed by means of fine sandpaper, or the timer tightened. The spark plug may be dirty and should be cleaned. To do this the battery switch should be opened, the spark plug unscrewed, and taken apart if necessary so that the end of the plug and the insulated rod can be cleaned; and then the plug tested by laying it on the cylinder, and pushing the car as already explained. Weak batteries may be the cause of misfiring because a spark may not be given continuously at the spark plug. The batteries may be only polarized and will perhaps work again if they are not used for half an hour. In an emergency, cut a hole in the top of each cell and pour in two teaspoonfuls of water. This may cause the battery to give enough current to carry the car a few miles.

**Back firing** is another trouble; it may have its source in one or more of the following causes: If the engine back fires through the carbureter, the inlet valve to the cylinder may be stuck open or may be broken. In the former case it should be operated by hand until it opens and closes properly. The timer may be loose or so improperly set that the spark occurs late in the explosion stroke of the piston. This will permit the inlet valve to open before the previous charge has been burned, particularly in two-cycle engines where the exhaust of one charge and the intake of the next occur at practically the same time. The timer may be loose or so improperly set that the spark occurs too early in the compression stroke, thus causing the engine to run backwards. Carbon deposits on the cylinder walls or piston may become so hot as to cause the explosion to occur too early in the compression stroke, or the cylinders may become heated to such a degree as to cause the explosion too early in the compression stroke.

## HANDLING SECOND HAND RAILS AND FASTENINGS ON BRANCH LINES.

By P. H. HAMILTON,

St. Louis & San Francisco, Neodesha, Kan.

Several railroads have elaborate systems for sorting out, cutting off and rerolling rails released from main lines for use on branch lines; but on most roads it is customary to ship released rails direct from the point of release to the place where they are to be relaid. In many instances the foreman loading the released rail cares little about the trouble or expense he may cause the man who is to relay it.

Where released rails are being shipped to another division for immediate relaying, the man in charge of the shipping should see that the rails are loaded so that they require the least handling at their destination, and to prevent delays to the rail gang. Rails should be loaded from both sides of the car, and the foreman in charge of the unloading should see that they are unloaded from the same side they came up on. By examining the ball of the rail the man on top of the car can tell which side they should be rolled off on, and can eliminate the necessity of the tong men turning the rails. If possible, rails of only one length should be loaded on a car, all short rails being loaded separately. This will enable the gang laying the rails to keep the joints properly "broken," and the short rails can be used around switches, crossings, etc. It is a costly proposition for a foreman to keep 10 or 12 men ahead of the rail gang matching up rails because the party loading the rails has given no attention to this detail.

When unloading rail the foreman should be furnished with a list of the material on each car so that he can arrange to dispose of the short rails, or battered and curve worn rails with the minimum amount of handling. It should not be necessary to unload a lot of short pieces out on the line and then have to pick them up with a work train. Frogs and switch material should not be loaded on the same car with rails. If it is necessary to unload rail and sort it out, this should be done in yards, and the cars should be "spotted" so that there will be no charge for train service. However, the proper time to sort rail is as it is being picked up along the track.

It is preferable to use new joints on relaying rail to make good track, but it is often necessary to use the joints released with the rail. In case second hand joints are to be used they should be loaded on the cars with the rails. When the rail is to be laid immediately after distribution, and new joints are to be used, the joints should be distributed with the rail, to save train service and to get the proper distribution. When the joints are received ahead of the rails they should be piled at a station in a convenient place for reloading, and be reloaded and distributed with the rail.

In loading rails by hand the unison-man should always stand on top of the car. He should be provided with a rail fork, and in addition to "bawling out" he should line the rails up after they are thrown on the car and see that each rail lies straight with the car. If the car is properly loaded, and the rails lie straight the load will not shift endwise, and bulkheads will not be necessary for short hauls.

Much valuable time is wasted in applying rusty bolts and rusty joints, and for this reason it is important that all track material be kept as free from rust as possible. If possible, all small material should be unloaded out of the weather, and should be distributed only a short time before it is to be used. Guard rails, switch rods, and other track fixtures are generally shipped out to the work with all the bolts and nuts in place. When they are first received, the bolts and nuts are greasy, but a few days in the weather soon rusts them so that when placing a guard rail or a switch rod, it costs more to remove the nuts from the bolts than it does to apply the fixture.

Track spikes and track bolts should not be kept where they are exposed to the weather, and rail joints should be kept off the ground until they are to be applied. Rusty track spikes are

harder to drive, and are more apt to "fly," causing personal injuries. Rusty track bolts and rail joints are hard to apply, and they increase the cost of maintenance of tight joints. It is hard to make a rusty joint fit up against the rail properly. We always oil the continuous joints where they fit against the base of the rail, which cuts the rust and allows the joint to get a good bearing against the base of the rail. A barrel of crude petroleum oil will grease the joints on about five miles of track.

The foreman in charge of the rail gang should have an extra box car in which to carry his supply of bolts, spikes and small material. He should replenish this supply at the various stations when necessary, and should take out with him from camp each day only what he will need that day. This insures his having good material to work with, saves the time of men running back and forth along the track looking for material, and no new material is left behind.

Trackmen dislike using rusty second hand spikes, on account of their being hard to drive. When a large supply of second hand spikes is accumulated the foreman should throw them on a pile of old ties and burn them. The expansion from the heat removes the rust, and makes them much easier to drive.

### SCALE SHOPS.\*

The size and requirements of a shop to repair scales only are not as extensive in character and detail as for one for their manufacture. The machinery need not generally be as extensive and elaborate, especially when the scale shop is located near other shops, where much of the machine work may be economically performed. However, the apparatus for testing, sealing and gaging is not essentially different in a manufacturing and a repair shop. The following requirements in the layout of a scale shop, with the necessary machinery, testing apparatus, etc., are suggested for a shop adapted both for manufacture and repair.

The ideal scale shop should be self-contained, consisting of an independent or separate building located on the ground floor, well lighted and ventilated in such a manner as to provide materially against air currents, which interfere with the proper sealing of levers. Independent foundations should be provided for all the machinery, to eliminate vibratory conditions as far as possible.

By way of suggestion, at least, for some of the larger railroads, it has been found that a suitable shop for both manufacturing and repairs, requires a floor area of about 7,500 sq. ft., an outside storage space of probably 70 ft. x 20 ft. for storing and the assembling of scales, structural steel, etc., and another outside space 100 ft. x 60 ft. for the storage of miscellaneous parts and castings. If it is not desired to fabricate and assemble the steel bridges in the shop, additional space may be required on the outside of the building for this purpose.

The shop should be served by an overhead traveling crane of 30 tons capacity, the crane runway being extended outside the building over the storage space. Two tracks should enter the building, one leading to the master scale, which should be located in one corner of the building, where the travel in and out of the shop will not be great. The track leading to this scale should be used only for running on to the scale the test weight cars and other materials to be weighed. The other track should enter the building for a distance of two car-lengths, for the handling of material.

The following tool equipment is suggested for consideration, the size and kind to be determined by the requirements: One screw-cutting engine lathe, one turret lathe, one plain milling machine, one universal milling machine, one rack gear cutter for graduating and notching beams, one heavy shaper, one middle-sized shaper, one heavy radial drill, one upright drill press, one sensitive drill press, one plain grinder with double-end spindle for two emery wheels with top platen for grinding

face contacts on pivots, one disk grinder with tilting feed table, one buffing wheel, one bolt cutter and one universal shop saw.

Work-benches should be provided for the required number of men, with vises spaced not closer than 8 ft. apart, all vises to have compensating jaws, with swivel bases.

The following are suggested standards to properly equip a scale shop: One master scale to have a capacity of at least 100,000 lbs., sensitive to within the smallest graduation on the beam and to be of good design and workmanship. It should be located in one corner of the scale shop, under the direct supervision of the foreman, and built on an independent foundation, close to the entrance to the shop, to afford easy access for the test cars; one even arm master sealer's balance, with a capacity of not less than 50 lbs. and preferably 100 lbs. in each pan, with a sensibility of over two grains; one sealer's balance, having a capacity of 2 lbs. in each pan, with a sensibility of 1/10 grain; and a sufficient number of sealing beams, preferably with a multiple of 10 to 1, for all kinds of levers, as may be required. The more modern method of sealing is to use a compound beam, specially constructed for the purpose. In connection with this outfit there should be provided such trestles, horses, and other devices as may be necessary to suspend the various types of levers and beams to be sealed.

There should also be one set of Tobin bronze master weights ranging from 50 lbs. to 1/16 ounce and of "Class A" standard as provided by the United States Government Bureau of Standards, Washington, D. C., to be used as primary standards; one set of decimal grain weights, ranging from 10 grains to 1/1000 grain, or an equal quantity of accurately sealed weights of other denominations; five 500-lb., two 1,000-lb. and one thousand 50-lb. test weights, for testing the master scale, the values to be derived from the primary standards, with a permissible tolerance of 25 grains, either in excess or deficiency. These weights can be carried in cars used for road work, when desired. When this is done, however, they should be maintained to within 100 grains of their true value.

The equipment should also include one laying-off or surface table, of suitable size to meet requirements; a full assortment of micrometer gages for measuring pivot distances; also range bars or special straight edges for determining the range of pivots in beams or levers; one specially constructed overhead structure, for sealing trussed-levers and dormant scales; one heating furnace of suitable size, preferably gas. There may, of course, be additional apparatus and equipment needed to specifically meet all other requirements, but this can readily be determined as the organization is developed.

When the scale shop is located in close proximity to a car and locomotive shop, the forgings, pivots, etc., should for economical reasons be made in the regular blacksmith shop. The pivot work, however, should be done by men regularly assigned to this work, who should be thoroughly familiar with the requirements and with the best methods of heating and tempering. This will result in a great saving of work in the scale shop, such as fitting pivots in repair work, etc. The heating, forging, and tempering of pivots should be done in a special furnace equipped with a pyrometer to get the best possible results. Some of the scale shop machinery may be eliminated if practical and economical to perform the necessary work in a regular machine shop. It is also assumed that the necessary carpenter work can be done in the regular department for that work; also that the painting can be taken care of in the same way, as these parts of the work are of limited quantity and ordinarily would not be of sufficient volume to keep even a few men continually employed.

The men employed in the manufacture and repair of scales in the shop should be those who understand to some extent the theory, as well as the construction, of scales. A competent foreman should be employed, and he should select capable machinists with a conception for such work, who in a short time under proper schooling should be able to fill the requirements.

\*Abstract of a report presented to the American Railway Association at New York, May 21, 1913.

## General News.

The fifteenth annual convention of the Southern Railway Agents' Association was held at Atlanta, Ga., August 6, 7 and 8. Officers were re-elected for the ensuing year as follows: C. G. Walker, Louisville, president; C. E. Coffey, East St. Louis, vice-president; W. J. Townsend, Augusta, secretary, and J. M. Bryan, Columbia, treasurer.

A motor car on the Central New England, carrying track laborers, ran into a freight train near Pleasant Valley, N. Y., on Friday last and two men were killed and two injured. Both the car and the freight train were running at good speed at an obscure place in the road; and the result was a violent butting collision, completely wrecking the motor car.

The recent decision of the Court of Claims in favor of the Chicago & Alton, holding that the post office department had not been justified in calculating the average weight of mails by counting seven days in a week, appears to have been thus far without result. The collection of the judgment by the Alton depends on an appropriation by Congress; and in dealings with other roads the post office department continues the practice which was condemned by the court.

The Canadian Northern, on recommendation of its safety committees, has issued a bulletin to shippers, station agents and trainmen announcing that in order to check the growing and dangerous tendency to increased loading heights of logs and lumber the extreme height of load to be permitted hereafter will be 15 ft. above the top of the rail. Stakes may be extended 2 ft. higher. Agents and conductors will refuse to accept loads not in conformity with these rules.

The Canadian Brotherhood of Railway Employees has received from the general manager of the government railways a letter to the effect that the employees of the Intercolonial will be granted increases of pay dating from March last. It appears that some of these increases have already been announced, but that further action will be taken in order to put all classes of employees on a basis of equality. It is said that about two thousand persons will be affected and that the gross increase will be about \$120,000 yearly.

C. M. Wood, flying in a monoplane, attempted, last Friday, to go from New York to Washington without landing, but he was compelled by trouble with his motor to alight at Gaithersburg, Md., 18 miles short of Washington. He started from Hempstead, L. I., about 4:30 a. m., and traversed the distance of about 287 miles in four hours, thirty-one minutes. He followed the Pennsylvania Railroad, and had a special train on that road to serve as a guide, but he flew at great height and the railroad was out of his sight nearly all of the time.

Senator Lea of Tennessee has introduced in Congress a resolution calling upon the Interstate Commerce Commission to investigate the relations of the Louisville & Nashville to certain of its subsidiary lines. The senator explains that there is a fear in Tennessee that the Louisville & Nashville will absorb the Tennessee Central and bring the entire state under the domination of the L. & N. The resolution calls on the commission to see what money the L. & N. has spent for maintaining political agents, for furthering political campaigns, or for the prevention of the construction of other railroads.

The Interstate Commerce Commission has ordered all common carrier telephone companies to furnish by October 1 a detailed statement of their organization and equipment and physical and financial operations. This is the first important order of the commission in relation to telephones. The commission has made an extensive inquiry, special agents of the commission having gathered a large quantity of data bearing upon the operation of telephone companies. As soon as practicable the commission will hold in various parts of the country public hearings concerning the rates and operating methods of such companies as come within the jurisdiction of the commission.

W. B. Spaulding, chairman, Central Safety Committee, St. Louis & San Francisco, reports that for the 12 months ending June 30, 1913, as compared with the same 12 months prior to the inauguration of the Safety First work on the Frisco, there

were 18 less trainmen killed, or a reduction of 62 per cent.; 413 less trainmen injured, a reduction of 35 per cent.; one less switchman killed, a reduction of 17 per cent.; and 13 less switchman injured, a reduction of 5 per cent. This makes a total of 445 less casualties to trainmen and switchmen. Mr. Spaulding holds that these reductions were unquestionably effected by the activity of the committeemen and other employees interested in personal injury prevention work. The record discloses that in every instance on any division where there was considerable activity in looking out for and quickly repairing defects in appliances on cars which trainmen and switchmen had to use, there immediately followed a radical reduction in the number of casualties to trainmen and switchmen.

The general safety committee of the Baltimore & Ohio has issued to employees a bulletin announcing that the number of fatal injuries happening to employees on the road during the month of July, is the lowest since the records have been kept—that is, for over two years. But three employees were fatally injured, and one of these was off duty. In all three of the cases the victim stood on or entered the track immediately in front of a train, with his eyes open and apparently in possession of all his senses. The lesson of all three was simply that we should form the habit of looking in both directions before stepping on a running track. The president of the road, Daniel Willard, writing in the *Baltimore & Ohio Employees' Magazine* for July, thanks the officers and employees of the company for what they have done in support of the policy of "Safety First," and appeals to every employee to make still further efforts to promote safety. Employees are requested to report, either by interview or by letter, everything which may indicate a dangerous condition; and by way of providing against every possible cause for reluctance, Mr. Willard says that facts in this field may be sent direct to him by letter; and such letters will be treated as confidential if the writer so desires.

A copy service department has been established by the Union Switch & Signal Company, Swissvale, Pa., and a bulletin has been issued telling of its uses. It is intended for the benefit of railroad companies which may wish to use information about their signals as features of their time tables or other advertising matter. A road on which the Union signals are in service may have the benefit of this new bureau without charge, not only for folders and such like documents, but also in the preparation of "news stories," or anything which may be intended to attract the attention of the public. It pays a road, says this bulletin, to advertise the fact that it is operated under the automatic block system. People have grasped the fact that automatic block signals are promoters of safety. The bureau will translate technical language into words that will be comprehended by the public, and at the same time will be characterized by accuracy. With the resources of the bureau no railroad advertising department need make the mistake (which has been made more than once) of showing signals wrong side up or wrong side out, or so arranged as to lead trains into danger. It is suggested that souvenir post cards may be filled with such good advertising that they can be sold for money.

### New Station at Westerly.

The New York, New Haven & Hartford has just finished extensive improvements at Westerly, R. I., including a new passenger station, freight yard and freight house, and the elevation of the main tracks. A sharp curve has been taken out and a number of grade crossings eliminated. The cost of the crossing changes was borne in part by the city of Westerly. The passenger station is 123 ft. x 49 ft. and the platforms are 750 ft. long. The freight house is 250 ft. x 50 ft. and the freight yard has 8 tracks.

### Railway Theatricals Up-to-Date.

Predetermined collisions of locomotives, which were quite fashionable a few years ago, have not been heard of for a long time; but the idea is not dead, and now it is to be perpetuated in moving pictures. According to the *New York World* a butting collision was "pulled off" in fine style, on the Raritan River Railroad, near South River, N. J., August 3, at the expense of the Vitagraph Company of America; and there were on hand the proper quota of actors and actresses to impersonate the



people who were killed, injured or distressed by the collision. The man who managed the camera escaped, by only three feet, a heavy piece of the locomotive which was thrown off, and struck the ground near him. After the preliminary scene had been gone through with, a car was set afire and the actors, substituting for themselves dummies where necessary, made a "rescue" scene. When the imaginary excitement was over the company of actors, said to be two hundred, sat down under the trees and partook of beer and sandwiches. The cost of this "act" is said to have been \$35,000.

#### Condition vs. Theory.

While northwestern Oklahoma is not the only part of the state that is suffering for additional transportation facilities, that section of the state probably needs more steel rails than does any other locality of Oklahoma.

When the people of the northwestern part of the state, a vast empire, larger than several New England states, use their best efforts to secure the repeal of section 9 of article ix of the state constitution, they will have taken the first step toward getting more railroads for the convenience of the people who now are forced to haul grain and merchandise over long and rough roads.

If there had been no article ix, section 9, C. G. Jones would have built a road from Oklahoma City to the northwestern part of the state. Mr. Jones built three railroads, and at the time of his death two years ago he was contemplating the construction of other lines, awaiting only the repeal of the prohibitive section of the constitution. After borrowing \$5,000,000, which he used to build railroads in Oklahoma, Mr. Jones found that the financiers refused to supply more funds to construct railroads that were prohibited by our constitution from being sold or leased to other lines.

At the time that the constitution was adopted, there was a sentiment which favored these restrictions. But we have seen that this section is a barrier and blocks development. It is time to stop fooling ourselves and to show that we are as progressive as we claim to be. It is time to repeal section 9 of article ix.—*Daily Oklahoman*.

#### The Public Makes No Demands.

Secretary Elliott of the International Travel Club has done well to call attention to the fact that when several railways lengthened the running time of their exceptionally fast trains they received only commendation from that public to whose insistent and compelling demand the putting on of such trains has so often been ascribed. Travelers do, indeed, prefer fast to slow trains, but they assume that the managers of railways know at what rate danger begins, and that they will not exceed or even approach it closely. The public influences speeds only by its willingness to take the faster of the trains which the companies in their competitions with each other see fit to provide. An article in this month's *Atlantic* on the lesson of the *Titanic* is marred by a like mistake as to the "demands" of travelers by sea. The writer blames the public for the magnificence and luxury of the enormous vessels now provided. But the public assumes that when they add Roman baths and gymnasiums and restaurants of stately expanse and gorgeous decoration to the simpler equipments of other days the ship owners keep the ultimate desideratum, safety, constantly in mind. Of course, we landsmen accept luxury gladly enough when it is offered to us and we can afford it, but the only real demand for the luxuries comes through stockholders hungry for dividends and from officers eager to draw traffic from other lines.—*New York Times*.

#### An Automatic (?) Speed Control.

The recent distressing series of fatal accidents on Long Island shows clearly enough the need of removing or guarding grade crossings. The remedy, of course, is to remove the crossings wherever that can be done, but when all the money which can be raised for this purpose has been spent there will still remain hundreds of grade crossings. Caution, however, is the one quality which drivers of fast cars seem determined not to use. To meet that emergency a man in Mount Vernon comes forward in the *New York Times* with a simple plan which would compel

caution on the part of the very people least disposed to exercise it. Instead of a straight road he would build a square block in the center of the highway, which would compel vehicles to turn a right angle to the right before crossing and another turn afterward to get back into the main highway. No sober driver of a car would try to take these four sharp corners at high speed; and when he has slowed down he can hear and see a train if one is approaching. Undoubtedly speed maniacs will protest volubly at any regulation which compels them to go slow, but the automobile clubs ought to welcome this provision. The cost would be trifling and the block crossings could easily be set up in rural neighborhoods where there is no money to lower the grade of the highway.—*Brooklyn (N. Y.) Eagle*.

#### Exhibitors at the Traveling Engineers' Convention.

Among the exhibitors at the convention of the Traveling Engineers' Association, held at the Hotel Sherman, Chicago, August 12-15, were the following:

- American Arch Company, New York, N. Y. Represented by W. L. Allison, J. T. Anthony, F. G. Boomer, G. O. Denney, C. E. Miller, J. P. Neff, LeGrand Parish, K. Tate and Geo. Wagstaff.
- American Locomotive Company, New York, N. Y.—Photographs and literature. Represented by C. A. Delaney, A. M. Sheffer, W. J. Becker, F. V. Kennedy and W. P. Steele.
- American Steel Foundries, Chicago, Ill.—Simplex couplers, Vulcan brake beam, economy draft arm, Vulcan truck, Andrews side frame and Simplex bolster. Represented by W. G. Wallace, W. A. Wallace and F. A. Lorenz, Jr.
- Ashton Valve Company, The, Boston, Mass.—Boston and Chicago air gages, appliances and safety valves. Represented by J. F. Gettrust and C. B. Foster.
- Barco Brass & Joint Company, Chicago, Ill.—Flexible joints, engine, tender, steam and air connections. Represented by F. N. Baird.
- Bettendorf Company, The, Davenport, Iowa.—Model underframe and truck. Represented by J. G. Hope.
- Brown & Co., Tom, Chicago, Ill.—Lovejoy expanders, jacks and tools. Represented by Tom Brown and Harry W. Stannard.
- Chicago Car Heating Company, Chicago, Ill.—Heating appliances. Represented by J. E. Buker and E. E. Smith.
- Commercial Acetylene Railway Light & Signal Company, New York, N. Y.—Acetylene headlights and signal lights. Represented by H. G. Doran.
- Crane Company, Chicago, Ill.—Valves and fittings. Represented by Frank D. Fenn, G. S. Turner and F. W. Venton.
- Dearborn Chemical Company, Chicago, Ill. Represented by J. F. Franc, C. S. Murray, W. S. Reid, I. H. Bowen, C. B. Hennessey, J. D. Purcell and J. F. Roddy.
- Detroit Lubricator Company, Detroit, Mich.—Detroit lubricators. Represented by A. D. Homard and R. H. Lindman.
- Dickerson Manufacturing & Supply Company, Clinton, Ill.—Water gages. Represented by C. L. Dickerson and F. H. Hinckley.
- Dixon Crucible Company, Joseph, Jersey City, N. J.—Graphite productions. Represented by H. C. Sorenson, L. H. Snyder and F. R. Brandon.
- Emery Pneumatic Lubricator Company, St. Louis, Mo.—Emery brake cylinder lubricant and automatic lubricators for pneumatic devices. Represented by H. C. Millar and E. A. Emery.
- Equipment Improvement Company, New York, N. Y.—Markel devices and Wine side bearings for cars and tenders. Represented by W. E. Weatherly.
- Franklin Railway Supply Company, New York, N. Y.—Franklin fire door. Represented by W. L. Allison, R. G. Coburn, W. H. Coyle, Jos. Sinkler and Hall R. Stafford.
- Galena Signal Oil Company, Franklin, Pa. Represented by W. E. Brumble, J. A. Roosevelt, Fred Smith, M. Meehan, J. A. Linahan, G. E. McVicker, Bloss Carey, Joe Arn, E. N. Sedwick, P. H. Stack, L. H. Palmer, W. J. Walsh, Dan Enbanks and Wm. Holmer.
- Gold Car Heating & Lighting Company, New York, N. Y.—Locomotive reducing valves, latest improved wedge locked steam hose couplings and temperature controls. Represented by W. H. Stocks and A. D. Stuver.
- Greene, Tweed & Company, New York, N. Y.—Palmetto packing and Favorite reversible ratchet wrench. Represented by A. J. Richardson and L. J. Van De Wall.
- Hammett, H. G., Troy, N. Y.—Radius grinder and Trojan metallic packing. Represented by E. C. Sawyer.
- Hunt-Spiller Manufacturing Corporation, Boston, Mass.—Gun iron for locomotive castings. Represented by J. G. Platt, V. W. Ellet and J. M. Monroe.
- Jenkins Bros., New York, N. Y.—Valves and packing. Represented by B. J. Neely.
- Jerguson Manufacturing Company, The, Boston, Mass.—Wiltbonco water gages. Represented by H. M. Waters.
- Jerome-Edwards Metallic Packing Company, Chicago, Ill.—Packing. Represented by L. E. Bulter and George C. Jerome.
- Johns-Manville Company, H. W., New York, N. Y.—Armored squirt hose and packing. Represented by D. L. Jennings.
- Keystone Lubricating Company, Philadelphia, Pa.—Keystone driving box.
- Leslie Company, The, Lyndhurst, N. J. Represented by J. J. Cizek and S. Inglis Leslie.
- Liberty Manufacturing Company, Pittsburgh, Pa.—Boiler tube and locomotive arch tube cleaners. Represented by S. A. Bockius and Chas. C. Hughes.
- Locomotive Stoker Company, New York, N. Y.—Represented by F. H. Philbrick.
- Locomotive Superheater Company, New York, N. Y. Represented by C. W. Wickham, John Bell, Geo. L. Bourne, Geo. Fogg, B. G. Lynch, R. M. Ostermann, F. E. Schaff, W. G. Tawse, G. E. Ryder, G. E.

- Spengler, Wm. Boughton, W. A. Buckber, C. D. Hilferty, A. C. McLachlan and R. R. Porterfield.
- McCord & Company, Chicago, Ill.—Locomotive force feed lubricator. Represented by R. L. McIntosh, L. H. Neal, W. J. Schlocks, H. S. Whitehair and H. E. Creer.
- Manning, Maxwell & Moore, Inc., New York, N. Y.—Valves, gages and inspirators. Represented by J. H. Bush, C. L. Brown, F. R. Smith and F. J. Wilson.
- Mark Manufacturing Company, Chicago, Ill.—Cold drawn steel unions. Represented by M. K. Kimberly and J. V. Larson.
- Moon Manufacturing Company, Chicago, Ill.—Headlights. Represented by H. E. Procutier and F. E. Hutchison.
- Mudge & Company, Chicago, Ill.—Mudge-Slater spark arrester. Represented by B. W. Mudge, G. W. Bender, Robt. D. Sinclair and Robt. M. Smith.
- Nathan Manufacturing Company, Chicago, Ill.—Steam boiler supplies. Represented by J. C. Currie, J. S. Suley and A. S. Work.
- National Boiler Washing Company, Chicago, Ill.—Photographs and descriptions. Represented by E. B. White.
- National Graphite Lubricator Company, The, Scranton, Pa.—Graphite lubricators. Represented by L. S. Watres and D. J. Lewis.
- National Railway Devices Company, Chicago, Ill.—Shoemaker fire door. Represented by Jay G. Robinson.
- National Tube Company, Pittsburgh, Pa.—Kewanee specialties, N. T. C. regrinding valves and National pipe. Represented by B. F. Bart and L. R. Phillips.
- Ohio Injector Company, The, Chicago.—Injectors, lubricators and flange oilers. Represented by A. C. Beckwith, Frank W. Furry, Wm. S. Furry, F. W. Edwards and F. B. Wipperman.
- Okadee Company, The.—Blow-off cocks, water glasses and water hose couplings. Represented by A. G. Hollingshead and H. L. Winalow.
- O'Malley-Bearse Valve Company, Chicago, Ill.—Multiplate valves. Represented by Edward O'Malley and Thos. O'Malley.
- Parkesburg Iron Company, Parkesburg, Pa.—Charcoal iron boiler tubes. Represented by J. H. Smythe, J. A. Kinkead and L. P. Mercer.
- Parsons Engineering Company, Wilmington, Del.—Photographs showing elimination of smoke from locomotives and details of the equipment. Represented by Wm. H. Savery and John H. Parsons.
- Paxton-Mitchell Company, Omaha, Neb.—Piston rod and packing. Represented by W. M. Leighton.
- Pilliod Company, The, Swanton, Ohio.—Miniature locomotive operating with the Baker gear. Represented by R. G. Graham, Fred E. Pilliod and F. S. Wilcoxon.
- Pyle-National Electric Headlight Company, Chicago, Ill. Represented by E. B. Barris, W. T. Bretherton, J. W. Johnson, J. E. Kilker, R. L. Kilker, E. E. Kirran, G. H. Matthews, C. P. McGinnis and Wm. Miller.
- Standard Heat & Ventilation Company, New York, N. Y.—Heating and ventilating equipment. Represented by Wm. C. Hermsen, E. C. Post and A. L. Whipple.
- Storrs Mica Company, Owego, N. Y.—Mica headlights. Represented by Tom Brown, Harry W. Stannard and Chas. P. Storrs.
- Strong, Carlisle & Hammond Company, Cleveland, Ohio.—Randall graphite sheet lubricator. Represented by H. P. Prescott and B. E. Carpenter.
- Syracuse Faucet & Valve Company, The, Syracuse, N. Y.—Syracuse valves. Represented by Jos. F. Brightman and S. B. Groner.
- The New York Air Brake Company, New York, N. Y. Represented by B. Hyanes, Geo. Kleifges, M. LaQuay, Robt. G. Parker and Wm. Owens.
- United States Metallic Packing Company, Philadelphia, Pa.—Packing, in-destructible oil cups and sanders. Represented by M. B. Brewster, H. M. Wey and C. L. Mellor.
- Universal Flexible Packing Company, Pittsburgh, Pa.—Air pump packing. Represented by John E. Chisholm.
- Watson-Stillman Company, The, New York, N. Y.—Chambers throttle valve. Represented by Frank H. Clark and G. R. Smith.

#### Federation of Trade Press Association.

The annual convention of the Federation of Trade Press Associations will be held at the Hotel Astor, New York, September 18-20. The subject of the opening meeting on the morning of September 18 will be Business Promotion Through Trade Press Efficiency, which will be followed by addresses by President H. M. Wilson of the New York Trade Press Association, President H. M. Swetland, of the Federation of Trade Press Associations, Secretary-Treasurer E. C. Johnston, of the same association, and by the presidents of the various local associations. R. R. Shuman, of the Shuman-Booth Company, Chicago, will deliver an address on The New Force in Business, which will be followed by an address on The Weakest Spot in Trade Press Efficiency by Elton J. Buckley, editor of *The Grocery World and General Merchant*.

Lunch will be served at the Thirty-ninth Street Publishers' building, followed by an inspection of the plant and publishing offices of the Federal Printing Company. The editorial symposium, under the leadership of A. I. Findley, of the *Iron Age*, will be held on the afternoon of September 18. At this symposium will be presented papers on general editorial subjects; also on the relations of editors with other departments.

On the same afternoon there will be the circulation symposium under the leadership of M. C. Robbins, at which papers will be presented from subscription managers, canvassers, and subscribers, giving views as to the value of the trade press and wherein it fails to be of value to them.

On September 19 there will be the advertising symposium, which will be under the leadership of Hugh M. Wilson, and at which papers will be presented by educators, publishers, advertisers, advertising managers and advertising agents.

At the business meeting will be told the inside stories of some of the big trade paper publishing successes. These speakers will treat the fundamental principles upon which each business was built. H. M. Swetland, president, will preside.

In the afternoon there will be a mass meeting at which there will be a number of addresses by representative men on subjects of live interest to editors, publishers, and advertisers. The banquet will be held on the evening of September 19 at the Hotel Astor. John Clyde Oswald, of the *American Printer*, will be toastmaster. The speakers will include the Hon. Albert S. Burleson, postmaster general; The Hon. William C. Redfield, secretary of the Department of Commerce; John Kendrick Bangs; Tom Daly; the Hon. Charles F. Moore and Dr. N. M. Waters.

The publishers' symposium will be held on the morning of September 20. Here will be discussed the policies, standards, and ideals of the trade paper publishing business. This symposium will be under the leadership of E. R. Shaw, of *The Practical Engineer*.

William H. Ukers, 79 Wall street, New York City, is chairman of the committee on arrangements.

#### International Engineering Congress.

Col. George W. Goethals, chairman of the Isthmian Canal Commission and chief engineer of the Panama Canal, has accepted the honorary presidency of the International Engineering Congress, and will preside over the general sessions to be held in San Francisco, Cal., September 20-25, 1915.

#### MEETINGS AND CONVENTIONS.

*The following list gives names of secretaries, dates of next or regular meetings, and places of meeting.*

- AIR BRAKE ASSOCIATION.—F. M. Nellis, 53 State St., Boston, Mass.
- AMERICAN ASSOCIATION OF DEMURRAGE OFFICERS.—A. G. Thomason, Boston, Mass. Convention, May 19, 1914, St. Louis.
- AMERICAN ASSOCIATION OF GENERAL PASSENGER AND TICKET AGENTS.—W. C. Hope, New York. Annual meeting, October 14-15, Philadelphia, Pa.
- AMERICAN ASSOCIATION OF FREIGHT AGENTS.—R. O. Wells, East St. Louis, Ill.
- AMERICAN ASSOCIATION OF RAILROAD SUPERINTENDENTS.—E. H. Harman, St. Louis, Mo.; 3d Friday of March and September.
- AMERICAN ELECTRIC RAILWAY ASSOCIATION.—H. C. Donecker, 29 W. 39th St., New York.
- AMERICAN ELECTRIC RAILWAY MANUFACTURERS' ASSOC.—H. G. McConaughy, 165 Broadway, New York. Meetings with Am. Elec. Ry. Assoc.
- AMERICAN RAILWAY ASSOCIATION.—W. F. Allen, 75 Church St., New York. Next meeting, November 19, 1913, Chicago.
- AMERICAN RAILWAY BRIDGE AND BUILDING ASSOCIATION.—C. A. Lighty, C. & N. W., Chicago. Convention, October 21-24, 1913, Montreal.
- AMERICAN RAILWAY ENGINEERING ASSOCIATION.—E. H. Fritch, 900 S. Michigan Ave., Chicago.
- AMERICAN RAILWAY MASTER MECHANICS' ASSOCIATION.—J. W. Taylor, Old Colony building, Chicago.
- AMERICAN RAILWAY TOOL FOREMEN'S ASSOCIATION.—A. R. Davis, Central of Georgia, Macon, Ga.
- AMERICAN SOCIETY FOR TESTING MATERIALS.—Prof. E. Marburg, University of Pennsylvania, Philadelphia, Pa.
- AMERICAN SOCIETY OF CIVIL ENGINEERS.—C. W. Hunt, 220 W. 57th St., New York; 1st and 3d Wed., except June and August, New York.
- AMERICAN SOCIETY OF ENGINEERING CONTRACTORS.—J. R. Wenlinger, 11 Broadway, New York; 2d Tuesday of each month, New York.
- AMERICAN SOCIETY OF MECHANICAL ENGINEERS.—Calvin W. Rice, 29 W. 39th St., New York.
- AMERICAN WOOD PRESERVERS' ASSOCIATION.—F. J. Angier, B. & O., Baltimore, Md. Next convention, January 20-22, 1914, New Orleans, La.
- ASSOCIATION OF AMERICAN RAILWAY ACCOUNTING OFFICERS.—C. G. Phillips, 143 Dearborn St., Chicago. Annual meeting, May 28, Atlantic City, N. J.
- ASSOCIATION OF RAILWAY CLAIM AGENTS.—J. R. McSherry, C. & E. I., Chicago.
- ASSOCIATION OF RAILWAY ELECTRICAL ENGINEERS.—Jos. A. Andreucetti, C. & N. W. Ry., Chicago. Annual convention, October 18-24, Chicago.
- ASSOCIATION OF RAILWAY TELEGRAPH SUPERINTENDENTS.—P. W. Drew, 112 West Adams St., Chicago.
- ASSOCIATION OF TRANSPORTATION AND CAR ACCOUNTING OFFICERS.—G. P. Conard, 75 Church St., New York.
- ASSOCIATION OF WATER LINE ACCOUNTING OFFICERS.—W. R. Evans, Chamber of Commerce, Buffalo, N. Y. Annual meeting, October 8, Philadelphia, Pa.
- BRIDGE AND BUILDING SUPPLY MEN'S ASSOCIATION.—H. A. Neally, Joseph Dixon Crucible Co., Jersey City, N. J. Meeting with American Railway Bridge and Building Association.

## Traffic News.

**CANADIAN RAILWAY CLUB.**—James Powell, Grand Trunk Ry., Montreal, Que.; 2d Tuesday in month, except June, July and Aug., Montreal.

**CANADIAN SOCIETY OF CIVIL ENGINEERS.**—Clement H. McLeod, 413 Dorchester St., Montreal, Que.; Thursday, Montreal.

**CAR FOREMEN'S ASSOCIATION OF CHICAGO.**—Aaron Kliné, 841 North 50th Court, Chicago; 2d Monday in month, Chicago.

**CENTRAL RAILWAY CLUB.**—H. D. Vought, 95 Liberty St., New York; 2d Thurs. in Jan. and 2d Fri. in March, May, Sept., Nov., Buffalo, N. Y.

**CIVIL ENGINEERS' SOCIETY OF ST. PAUL.**—L. S. Pomeroy, Old State Capitol building, St. Paul, Minn.; 2d Monday, except June, July August and September, St. Paul.

**ENGINEERS' SOCIETY OF PENNSYLVANIA.**—E. R. Daisher, Box 704, Harrisburg, Pa.; 1st Monday after 2d Saturday, Harrisburg, Pa.

**ENGINEERS' SOCIETY OF WESTERN PENNSYLVANIA.**—E. K. Hiles, Oliver building, Pittsburgh; 1st and 3d Tuesday, Pittsburgh, Pa.

**FREIGHT CLAIM ASSOCIATION.**—Warren P. Taylor, Richmond, Va.

**GENERAL SUPERINTENDENTS' ASSOCIATION OF CHICAGO.**—E. S. Koller, 226 W. Adams St., Chicago; Wed. preceding 3d Thurs., Chicago.

**INTERNATIONAL RAILWAY CONGRESS.**—Executive Committee, 11, rue de Louvain, Brussels, Belgium. Convention, 1915, Berlin.

**INTERNATIONAL RAILWAY FUEL ASSOCIATION.**—C. G. Hall, 922 McCormick building, Chicago.

**INTERNATIONAL RAILWAY GENERAL FOREMEN'S ASSOCIATION.**—Wm. Hall, 829 West Broadway, Winona, Minn.

**INTERNATIONAL RAILROAD MASTER BLACKSMITHS' ASSOCIATION.**—A. L. Woodworth, Lima, Ohio. Annual meeting, August 18, Richmond, Va.

**MAINTENANCE OF WAY & MASTER PAINTERS' ASSOCIATION OF THE UNITED STATES AND CANADA.**—W. G. Wilson, Lehigh Valley, Easton, Pa.

**MASTER BOILER MAKERS' ASSOCIATION.**—Harry D. Vought, 95 Liberty St., New York.

**MASTER CAR BUILDERS' ASSOCIATION.**—J. W. Taylor, Old Colony building, Chicago.

**MASTER CAR AND LOCOMOTIVE PAINTERS' ASSOC. OF U. S. AND CANADA.**—A. P. Dane, B. & M., Reading, Mass. Annual meeting, September 9-12, Ottawa, Can.

**NATIONAL RAILWAY AFFLIANCE ASSOC.**—Bruce V. Crandall, 537 So. Dearborn St., Chicago. Meetings with Am. Ry. Eng. Assoc.

**NEW ENGLAND RAILROAD CLUB.**—W. E. Cade, Jr., 683 Atlantic Ave., Boston, Mass.; 2d Tuesday in month, except June, July, Aug. and Sept., Boston.

**NEW YORK RAILROAD CLUB.**—H. D. Vought, 95 Liberty St., New York; 3d Friday in month, except June, July and August, New York.

**NORTHERN RAILROAD CLUB.**—C. L. Kennedy, C., M. & St. P., Duluth, Minn.; 4th Saturday, Duluth.

**PEORIA ASSOCIATION OF RAILROAD OFFICERS.**—M. W. Rotchford, Union Station, Peoria; 2d Thursday.

**RAILROAD CLUB OF KANSAS CITY.**—C. Manlove, 1008 Walnut St., Kansas City, Mo.; 3d Friday in month, Kansas City.

**RAILWAY BUSINESS ASSOCIATION.**—Frank W. Noxon, 2 Rector St., New York. Annual dinner, second week in December, 1913, New York.

**RAILWAY CLUB OF PITTSBURGH.**—J. B. Anderson, Penna. R. R., Pittsburgh, Pa.; 4th Friday in month, except June, July and August, Pittsburgh.

**RAILWAY ELECTRICAL SUPPLY MANUFACTURERS' ASSOC.**—J. Scribner, 1021 Monadnock Block, Chicago. Meetings with Assoc. Ry. Elec. Engrs.

**RAILWAY FIRE PROTECTION ASSOCIATION.**—C. B. Edwards, Mobile & Ohio, Mobile, Ala. Next meeting, October 7, Chicago.

**RAILWAY GARDENING ASSOCIATION.**—J. S. Butterfield, Lee's Summit, Mo.

**RAILWAY DEVELOPMENT ASSOCIATION.**—W. Nicholson, Kansas City Southern, Kansas City, Mo.

**RAILWAY SIGNAL ASSOCIATION.**—C. C. Rosenberg, Bethlehem, Pa. Convention, October 14, Nashville, Tenn.

**RAILWAY STOREKEEPERS' ASSOCIATION.**—J. P. Murphy, Box C, Collinwood, Ohio.

**RAILWAY SUPPLY MANUFACTURERS' ASSOC.**—J. D. Corway, 2135 Oliver bldg., Pittsburgh, Pa. Meetings with M. M. and M. C. B. Assoc.

**RAILWAY TEL. AND TEL. AFFLIANCE ASSOC.**—W. E. Harkness, 284 Pearl St., New York. Meetings with Assoc. of Ry. Teleg. Sups.

**RICHMOND RAILROAD CLUB.**—F. O. Robinson, Richmond, Va.; 2d Monday except June, July and August.

**ROADMASTERS' AND MAINTENANCE OF WAY ASSOCIATION.**—L. C. Ryan, C. & N. W., Sterling, Ill. Convention, September 8-12, 1913, Chicago.

**ST. LOUIS RAILWAY CLUB.**—B. W. Frauenthal, Union Station, St. Louis, Mo.; 2d Friday in month, except June, July and Aug., St. Louis.

**SIGNAL AFFLIANCE ASSOCIATION.**—F. W. Edmonds, 3868 Park Ave., New York. Meeting with annual convention Railway Signal Association.

**SOCIETY OF RAILWAY FINANCIAL OFFICERS.**—C. Nyquist, La Salle St. Station, Chicago. Annual meeting, September 23-25, Chicago.

**SOUTHERN ASSOCIATION OF CAR SERVICE OFFICERS.**—E. W. Sandwich, A. & W. P. Ry., Montgomery, Ala.

**SOUTHERN & SOUTHWESTERN RAILWAY CLUB.**—A. J. Merrill, Grant bldg., Atlanta, Ga.; 3d Thurs., Jan., March, May, July, Sept., Nov., Atlanta.

**TOLLEDO TRANSPORTATION CLUB.**—J. G. Macomber, Woolson Spice Co., Toledo, Ohio; 1st Saturday, Toledo.

**TRACK SUPPLY ASSOCIATION.**—W. C. Kidd, Ramapo Iron Works, Hillsburn, N. Y. Meeting with Roadmasters' and Maintenance of Way Association.

**TRAFFIC CLUB OF CHICAGO.**—W. H. Wharton, La Salle Hotel, Chicago.

**TRAFFIC CLUB OF NEW YORK.**—C. A. Swope, 290 Broadway, New York; last Tuesday in month, except June, July and August, New York.

**TRAFFIC CLUB OF PITTSBURGH.**—D. L. Wells, Erie, Pittsburgh, Pa.; meetings monthly, Pittsburgh.

**TRAFFIC CLUB OF ST. LOUIS.**—A. F. Versen, Mercantile Library building, St. Louis, Mo. Annual meeting in November. Noontday meetings October to May.

**TRAIN DISPATCHERS' ASSOCIATION OF AMERICA.**—J. F. Mackie, 7042 Stewart Ave., Chicago.

**TRANSPORTATION CLUB OF BUFFALO.**—J. M. Sells, Buffalo; first Saturday after first Wednesday.

**TRANSPORTATION CLUB OF DETROIT.**—W. R. Hurley, L. S. & M. S., Detroit, Mich.; meetings monthly.

**TRAVELING ENGINEERS' ASSOCIATION.**—W. O. Thompson, N. Y. C. & H. R., East Buffalo, N. Y.

**UTAH SOCIETY OF ENGINEERS.**—Fred D. Ulmer, Oregon Short Line, Salt Lake City, Utah; 3d Friday of each month, except July and August.

**WESTERN CANADA RAILWAY CLUB.**—W. H. Rosevear, P. O. Box 1707, Winnipeg, Man.; 2d Monday, except June, July and August, Winnipeg.

**WESTERN RAILWAY CLUB.**—J. W. Taylor, Old Colony building, Chicago; 3d Tuesday of each month, except June, July and August.

**WESTERN SOCIETY OF ENGINEERS.**—J. H. Warder, 1735 Monadnock Block, Chicago; 1st Monday in month, except July and August, Chicago.

The Erie Railroad reports that it has transported during the past ten years 303,580,752 passengers without loss of life or limb.

The Southern Railway is planning to exhibit southern farm products at three expositions and at thirty-five district or county fairs in northern and western states within the next few months.

Sailings of steamships from Galveston for foreign ports with wheat average more than one a day. The number of vessels scheduled to sail in the month of August is 49, besides 25 coasting vessels.

The Maine Central announces that 500-mile tickets, price \$10, have been put on sale at all stations in New Hampshire, complying with a law of that state, passed at the last session of the legislature.

The movement of freight over the middle division of the Pennsylvania Railroad for the month of July is reported as the heaviest in the history of the road. The number of cars passing Denholm was 180,113, an increase of about 10,000 cars over the best previous record.

The Pennsylvania Railroad announces that with a view to making it more convenient for passengers to redeem unused tickets, agents have been instructed that if a ticket wholly unused is presented by the original purchaser at the ticket office at which it was sold, it may be redeemed for the fare at which it was sold.

The Louisville & Nashville on August 12 put into effect new passenger tariffs throughout the state of Alabama, based on a uniform rate of 2½ cents a mile. The order of the State Railroad Commission requiring the adoption of this rate was taken before the Federal Court last week with a view to making an appeal to the United States Supreme Court; but the judges decided against the company, and, apparently, the purpose to appeal has been dropped. This road has fought the low passenger rates in the State and Federal courts since 1906.

The Chicago & Alton has announced that its passenger trains will no longer stop at East St. Louis, but through trains between Chicago and St. Louis will be run over the Merchants' bridge, the east end of which is at Granite City. When the road abandoned the East St. Louis station some time ago protest was made to the Illinois Railroad and Warehouse Commission, and the company agreed to give service between Granite City and East St. Louis for one month on trial, and to continue the service if it proved profitable or even paid expenses. The test showed that but few passengers took advantage of the trains, and the commission has now given its permission to discontinue the service entirely.

The Eastern railroads are actively engaged in preparations to file freight tariffs showing the 5 per cent. increase heretofore spoken of; but there is no basis for the assertion that the roads are trying to force the commission to early action. After the application of the railroads for the advance the commission ordered an investigation of the whole matter on its own initiative. This disposition of the matter was entirely satisfactory to the railroads, but two of the members of the commission in a minority report held that the commission could not properly go into the matter unless actual tariffs had been printed and filed and were before the commission in evidence. In view of the objection raised by these two members, the railroads concluded to go ahead with the preparation of new tariffs.

The Department of Agriculture reports the general crop conditions on August 1 averaged for the United States 6.2 per cent. lower than on the same date last year, and 4.3 per cent. lower than the average condition on August 1 of recent years. The weather conditions about August 1 were unfavorable for the crops in general. Hot and dry weather has continued in Kansas, Missouri and neighboring states. The lowest conditions are found in Kansas with 31.6 per cent. below; Oklahoma, 18.0 per cent.; Kentucky, 13.6 per cent.; California, 12.8 per cent.; Illinois, 12.3 per cent., and Maryland with 12.2 per cent. below average conditions. The highest conditions are in Wisconsin

with 7.6 per cent.; Washington, 5.3 per cent.; Florida, 5.2 per cent., and Minnesota, 4.3 per cent. above the average conditions on August 1. The dry and hot weather throughout the southwest, which continued for 10 days without intermission, and caused much scarcity of water, was believed to have more than offset the effect of beneficial rains this week over Illinois, Nebraska, and Iowa. The Cincinnati *Price Current* estimates that 400,000,000 bus. of the growing corn have been destroyed by the drouth. The Chicago expert, Snow, assigned 300,000,000 bus. as the loss in June alone. Corn at Chicago, August 13, was quoted at the highest prices of the season; 73 cents a bushel for September, 68½ for December, and 69½ for May.

**Car Surpluses and Shortages.**

Arthur Hale, chairman of the committee on relations between railroads, of the American Railway Association, in presenting statistical bulletin No. 149, giving a summary of car surpluses

and shortages by groups from April 25, 1912, to August 1, 1913, says: The total surplus on August 1, 1913, was 69,716 cars; on July 15, 1913, 76,280 cars; and on August 1, 1912, 65,904 cars. Compared with the preceding period; there is a decrease in the total surplus of 6,564 cars, of which 2,438 is in box, 433 in flat, 4,393 in coal, and an increase of 700 in miscellaneous car surplus. The decrease in box car surplus is in all groups except 1 (New England lines), and 11 (Canadian lines). The decrease in flat car surplus is in groups 1 (as above), 3 (Ohio, Indiana, Michigan and Western Pennsylvania), 6 (Iowa, Illinois, Wisconsin and Minnesota), 7 (Montana, Wyoming, Nebraska and the Dakotas), 8 (Kansas, Colorado, Oklahoma, Missouri and Arkansas), and 10 (Washington, Oregon, Idaho, California, Nevada and Arizona). The decrease in coal car surplus is in all groups, except 1 (as above). The increase in miscellaneous car surplus, is in groups 1 (as above), 2 (New York, New Jersey, Delaware, Maryland and Eastern Pennsyl-

**CAR SURPLUSES AND SHORTAGES.**

Date.	No. of roads.	Surpluses				Shortages					
		Box.	Flat.	Coal, gondola and hopper.	Other kinds.	Total.	Box.	Flat.	Coal, gondola and hopper.	Other kinds.	Total.
Group *1.—August 1, 1913.....	7	1,013	205	124	142	1,484	12	70	144	2	228
" 2.—" 1, 1913.....	33	1,116	57	1,024	639	2,836	132	1	300	0	433
" 3.—" 1, 1913.....	33	4,607	341	340	2,321	7,609	419	81	1,263	29	1,792
" 4.—" 1, 1913.....	14	2,376	417	709	730	4,232	536	400	1,612	20	2,568
" 5.—" 1, 1913.....	27	441	39	150	578	1,208	215	206	425	3	849
" 6.—" 1, 1913.....	31	5,320	291	1,556	5,025	12,192	1,223	19	135	3	1,380
" 7.—" 1, 1913.....	5	76	19	202	176	473	738	0	0	93	831
" 8.—" 1, 1913.....	21	2,296	100	2,486	4,701	9,583	1,061	98	25	19	1,203
" 9.—" 1, 1913.....	14	1,023	230	195	792	2,240	600	0	53	8	661
" 10.—" 1, 1913.....	21	3,755	881	2,024	8,660	15,320	305	14	72	114	505
" 11.—" 1, 1913.....	6	10,650	208	0	1,681	12,539	348	443	0	20	811
Total .....	212	32,673	2,788	8,810	25,445	69,716	5,589	1,332	4,029	311	11,261

\*Group 1 is composed of New England lines; Group 2—New York, New Jersey, Delaware, Maryland and Eastern Pennsylvania lines; Group 3—Ohio, Indiana, Michigan and Western Pennsylvania lines; Group 4—West Virginia, Virginia, North and South Carolina lines; Group 5—Kentucky, Tennessee, Mississippi, Alabama, Georgia and Florida lines; Group 6—Iowa, Illinois, Wisconsin and Minnesota lines; Group 7—Montana, Wyoming, Nebraska, North Dakota and South Dakota lines; Group 8—Kansas, Colorado, Missouri, Arkansas and Oklahoma lines; Group 9—Texas, Louisiana and New Mexico lines; Group 10—Washington, Oregon, Idaho, California, Nevada and Arizona lines; Group 11—Canadian lines.

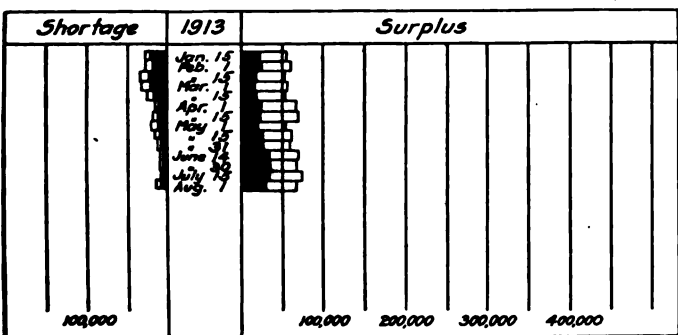
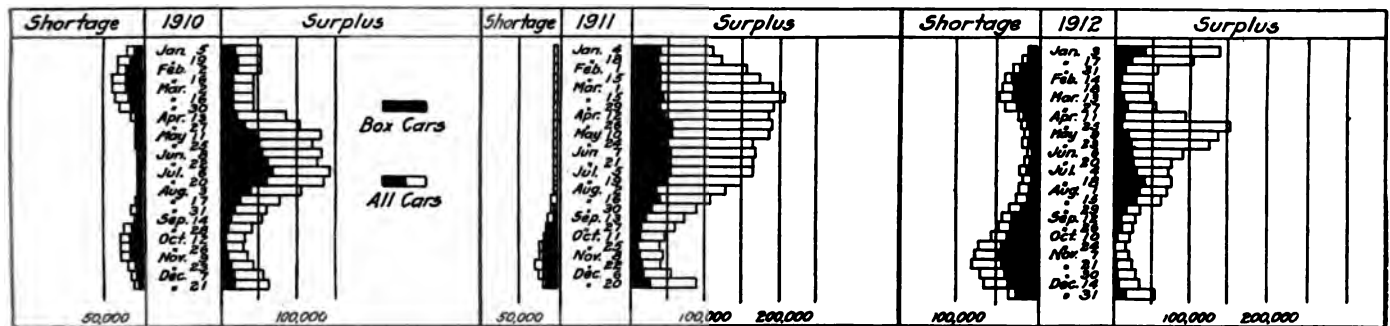
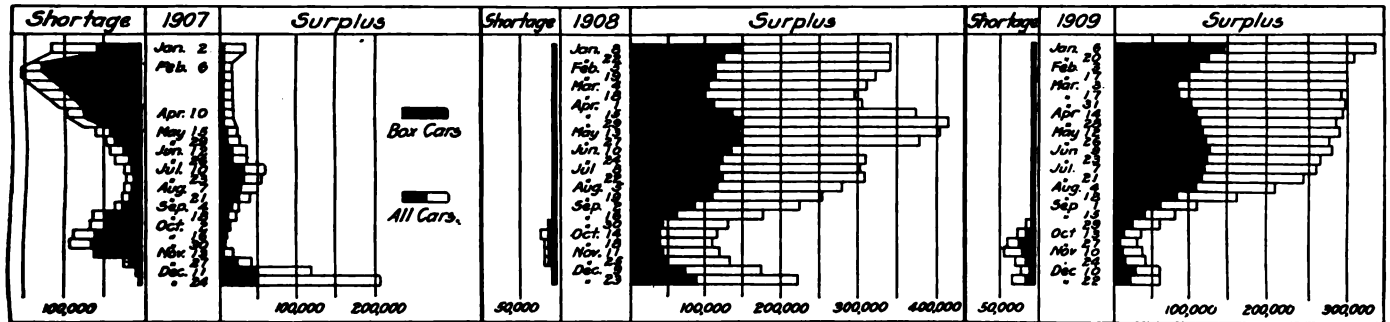

**Car Surpluses and Shortages, 1907-1913.**

vania), 5 (Kentucky, Tennessee, Mississippi, Alabama, Georgia and Florida), 6, 7, 8 and 11 (as above).

The total shortage on August 1, 1913, was 11,261 cars; on July 15, 1913, 6,875 cars; and on August 1, 1912, 9,394 cars. Compared with the preceding period; there is an increase in the total shortage of 4,386 cars, of which 2,428 is in box, 411 in flat, 2,203 in coal, and a decrease of 656 in miscellaneous car shortage. The increase in box car shortage is in all groups, except 2 and 5 (as above). The increase in flat car shortage is in groups 1, 2, 3 (as above), 4 (the Virginias and Carolinas), 8 and 11 (as above). The increase in coal car shortage is in all groups, except 8 and 10 (as above). The decrease in miscellaneous car shortage is in groups 1, 3, 6, 10 and 11 (as above).

Compared with the same date of 1912; there is an increase in

the total surplus of 3,812 cars, of which 4,639 is in box, 644 in flat, 1,683 in miscellaneous, and a decrease of 3,154 in coal car shortage. There is an increase in the total shortage of 1,867 cars, of which 1,392 is in box, 1,250 in coal, 138 in miscellaneous, and a decrease of 913 in flat car shortage.

The table on page 305 gives car surplus and shortage figures by groups for the last period covered in the report and the diagram shows total bi-weekly surpluses and shortages from 1907 to 1913.

**Car Location.**

The table on page 307, which is taken from bulletin No. 8-A of the American Railway Association, gives a summary of freight car location by groups on July 15, 1913.

**Car Balance and Performance.**

Arthur Hale, chairman of the committee on relations between railroads, of the American Railway Association, in presenting statistical bulletin No. 150, covering car balances and performances for April, says:

The miles per car per day, for April were 24.0, compared with 23.7 in March. This figure for April, 1912, was 23.3.

Ton miles per car per day, for April were 369, compared with 374 in March. This figure for April, 1912, was 340.

The proportion of home cars on line increased one point to 54 per cent. in April, 1913, compared with 53 per cent. in April, 1912.

The per cent. of loaded mileage for April decreased 0.6 per cent., to 69.4 per cent. This figure for April, 1912, was 69.1 per cent.

The average earnings per car per day for all cars on line were \$2.48, compared with \$2.47 in March. This figure for April, 1912, was \$2.34.

The table on this page gives the car balance and performance in the month covered by the report, and the diagram on page 307 shows car earnings and car mileage and different car performance figures monthly from July, 1907.

**Manufacturers' Railway and the Interstate Commerce Commission.**

The Manufacturers' Railway, St. Louis, announces that it will continue to operate its road notwithstanding that under the recent decision of the Interstate Commerce Commission (*Railway Age Gazette*, August 8, p. 247), it is unlawful for the trunk lines to continue the former allowances. The road will appeal to the courts, as no formal order was made. The opinion of the commission is declared by the officers of the road to be paradoxical. While permitting the Manufacturers' Railway to retain its status as a common carrier, at the same time it imposed conditions which are declared to be impossible. The road now receives a maximum of \$4.50 per car. The commission held that it was entitled to only \$2, but at the same time ruled that the trunk lines could not absorb even that small amount; that it should be charged in addition to the full rate to and from St. Louis. George F. Moore, president of the road, declaring that the new rate would put the Manufacturers' line out of business, has filed a protest with the commission. "The Manufacturers' Railroad could not live a day under the rates suggested by the commission's opinion," said Mr. Moore. "We cannot even receive car demurrage from the trunk lines. As each car is on our tracks about four days that means we receive only \$2 a car and have to pay out about the same sum for car rent. The Terminal Railroad Association receives about \$6 for each car it handles. The new rates have not been promulgated by an order of the commission. Until they are so promulgated we will continue to do business as at present. If an order fixing the \$2 rate is issued we will go into court and ask an injunction against its enforcement."

**INTERSTATE COMMERCE COMMISSION.**

**Complaint Dismissed.**

*National Lumber Exporters' Association v. St. Louis, Iron Mountain & Southern et al. Opinion by Commissioner Prouty:*  
The commission decided that the rate of 15 cents per 100 lbs. for the transportation of hardwood lumber from Pine Bluff and

CAR BALANCE AND PERFORMANCE IN APRIL, 1913.

	New England.	N. Y., N. J., Del., Md., Eastern Pa.	Ohio, Ind., Mich., Western Pa.	Va., W. Va., No. and So. Carolina.	Ky., Tenn., Miss., Ala., Ga., Fla.	Iowa, Ill., Wis., Minn.	Mont., Wyo., Neb., Dakotas.	Kan., Colo., Mo., Ark.	Texas, La., New Mex.	Oreg., Idaho, Nev., Cal., Ariz.	Canadian Lines.	Grand Total.
Revenue freight cars owned.....	89,771	687,841	220,708	188,875	171,261	423,999	18,526	144,413	31,365	136,064	134,732	2,247,555
Average number of system cars on line.....	42,698	353,489	122,316	100,468	77,406	5,858	5,858	71,236	19,441	65,946	87,393	1,224,903
Railway-owned cars: Average foreign on line.....	54,069	307,222	119,370	88,650	81,221	149,963	10,689	63,571	22,544	48,274	52,764	998,337
Excess.....	96,767	660,711	241,686	189,118	158,626	428,616	16,547	134,807	41,985	114,220	140,157	2,223,240
Per cent. of cars on line to total owned:.....	6,996	*27,130	20,978	243	*12,635	4,617	*1,979	*9,606	10,620	*21,844	5,425	*24,315
Home.....	48	51	55	53	45	66	31	49	62	48	65	54
Foreign.....	60	45	54	47	48	35	58	40	72	36	39	45
All railroads.....	108	96	109	100	93	101	89	89	134	84	104	99
Private cars on line.....	3,500	35,777	10,254	6,598	10,196	14,218	1,662	7,246	4,295	9,698	3,241	106,685
Total, all cars on line.....	100,267	696,488	251,940	195,716	168,822	442,834	18,209	142,053	46,280	123,918	143,398	2,329,935
No. of freight engines owned.....	5,98	5,38	8,93	6,63	9,33	5,95	7,08	7,15	6,18	5,79	4,65	6,58
Average cars on line per freight engine owned.....	1,446	10,431	3,075	3,435	2,892	6,985	545	2,887	891	2,806	2,192	37,605
Total freight car mileage.....	69	67	82	57	58	63	33	49	52	44	65	62
Average mileage per car per day.....	57,221,052	507,554,293	143,097,285	137,229,885	120,762,773	320,794,681	25,048,593	98,151,944	38,810,443	117,739,228	109,033,494	1,675,443,671
Per cent. loaded mileage.....	19.0	24.3	23.4	23.4	23.9	24.0	46.9	24.3	28.0	31.6	25.3	24.0
Ton-miles of freight, including company freight.....	74.4	67.9	72.5	70.7	69.9	70.7	69.9	66.3	62.6	68.7	76.0	69.4
Average ton-miles, including company freight:.....	688,182,503	8,398,548,693	2,254,270,152	2,038,172,416	1,719,395,395	3,645,088,117	366,755,812	1,393,978,254	465,903,183	1,649,925,567	1,800,766,240	24,420,988,332
Per car-mile.....	12.0	16.5	16.7	14.9	14.3	14.8	15.0	14.2	12.0	14.3	16.5	15.4
Per loaded car-mile.....	16.2	24.4	23.0	22.5	20.5	20.8	20.9	21.7	19.2	20.8	21.7	22.2
Per car per day.....	229	402	310	347	343	354	705	346	336	451	419	369
Gross freight earnings.....	\$7,525,204	\$49,276,562	\$13,211,214	\$12,707,938	\$11,719,194	\$32,585,952	\$2,778,757	\$11,062,306	\$3,878,686	\$16,600,515	\$11,439,691	\$172,786,019
Average daily earnings: Per car owned.....	\$2.79	\$2.40	\$2.00	\$2.24	\$2.28	\$2.56	\$5.00	\$4.12	\$4.08	\$4.08	\$2.83	\$2.56
Per railroad car on line.....	2.59	2.49	1.82	2.24	2.46	2.53	2.50	2.82	3.08	2.72	2.72	2.48
All cars on line.....	2.50	2.37	1.75	2.16	2.31	2.45	5.09	2.69	2.79	4.48	2.66	2.48

\*Denotes deficiency.

CAR LOCATION ON JULY 15, 1913.

	New England.	N.Y., N.J., Del., Md., Pa.	Ohio, Ind., Mich., Western Pa.	Va., W. Va., No. Carolina.	Ky., Tenn., Miss., Ala., Ga., Fla.	Iowa, Ill., Wis., Minn.	Mont., Wyo., Neb., Dakotas.	Kans., Colo., Okla., Mo., Ark.	Texas, La., New Mexico.	Oregon, Idaho, Nev., Cal., Ariz.	Canadian Lines.	Grand Total.
Total Cars Owned.....	87,932	680,443	272,455	202,858	*172,691	460,799	17,148	152,814	33,320	131,987	136,105	2,348,552
Home Cars on Home Roads.....	43,467	402,543	108,869	105,328	90,288	320,875	5,748	85,397	15,421	77,121	95,044	1,350,101
Home Cars on Foreign Roads.....	44,465	277,900	163,586	97,530	82,403	139,924	11,400	67,417	17,899	54,866	41,061	998,451
Foreign Cars on Home Roads.....	51,124	287,061	200,117	73,874	63,212	164,392	8,300	63,718	24,763	50,668	43,296	1,030,525
Total Cars on Line.....	94,591	689,604	308,986	179,202	153,500	485,267	14,048	149,115	40,184	127,789	138,340	2,380,626
Excess or Deficiency.....	6,659	9,161	36,531	*23,656	*19,191	24,468	*3,100	*3,699	6,864	*4,198	2,235	32,074
Surplus.....	1,265	9,953	4,660	5,182	2,322	14,257	552	12,885	2,495	17,148	5,561	76,280
Shortage.....	111	522	812	1,565	614	1,074	784	385	163	416	429	6,875
Shop Cars—												
Home Cars in Home Shops.....	5,522	42,072	18,689	12,786	15,853	25,462	683	10,939	2,686	5,189	4,776	144,657
Foreign Cars in Home Shops.....	1,435	8,867	7,705	2,482	1,933	4,838	546	2,481	1,040	2,639	586	34,552
Total Cars in Shops.....	6,957	50,939	26,394	15,268	17,786	30,300	1,229	13,420	3,726	7,828	5,362	179,209
Per Cent. to Total Cars Owned—												
Home Cars on Home Roads.....	49.43	59.16	39.96	51.92	52.28	69.63	33.52	55.88	46.28	58.43	69.83	57.49
Total Cars on Line.....	104.40	101.35	113.31	88.34	88.89	105.31	81.92	96.26	120.60	96.82	101.64	101.37
Home Cars in Home Shops.....	6.28	6.18	7.34	6.30	9.18	5.92	3.98	7.16	8.06	3.93	3.51	6.29
Foreign Cars in Home Shops.....	1.21	1.31	3.03	1.23	1.12	1.13	3.19	1.49	3.12	2.00	.43	1.50
Total Cars in Shops.....	7.49	7.49	10.37	7.53	10.30	7.05	7.17	8.65	11.18	5.93	3.94	7.79

\*Denotes deficiency.

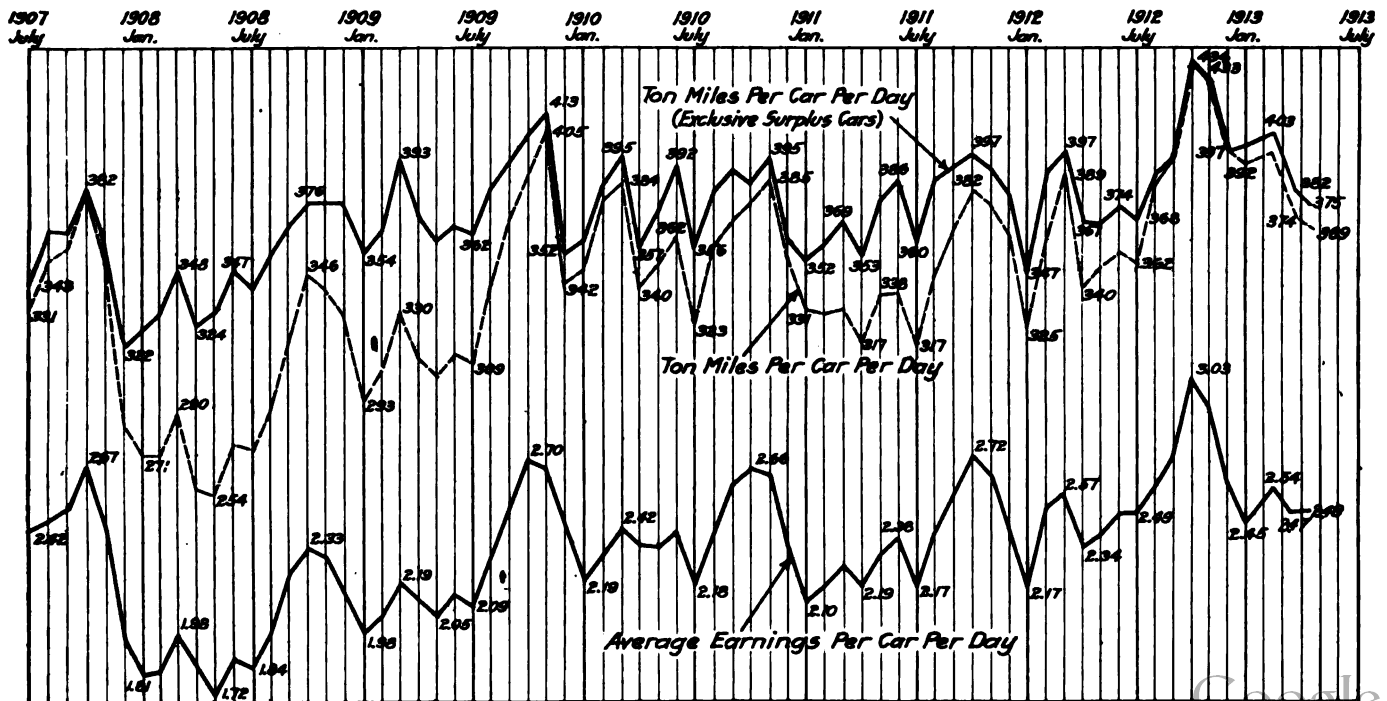
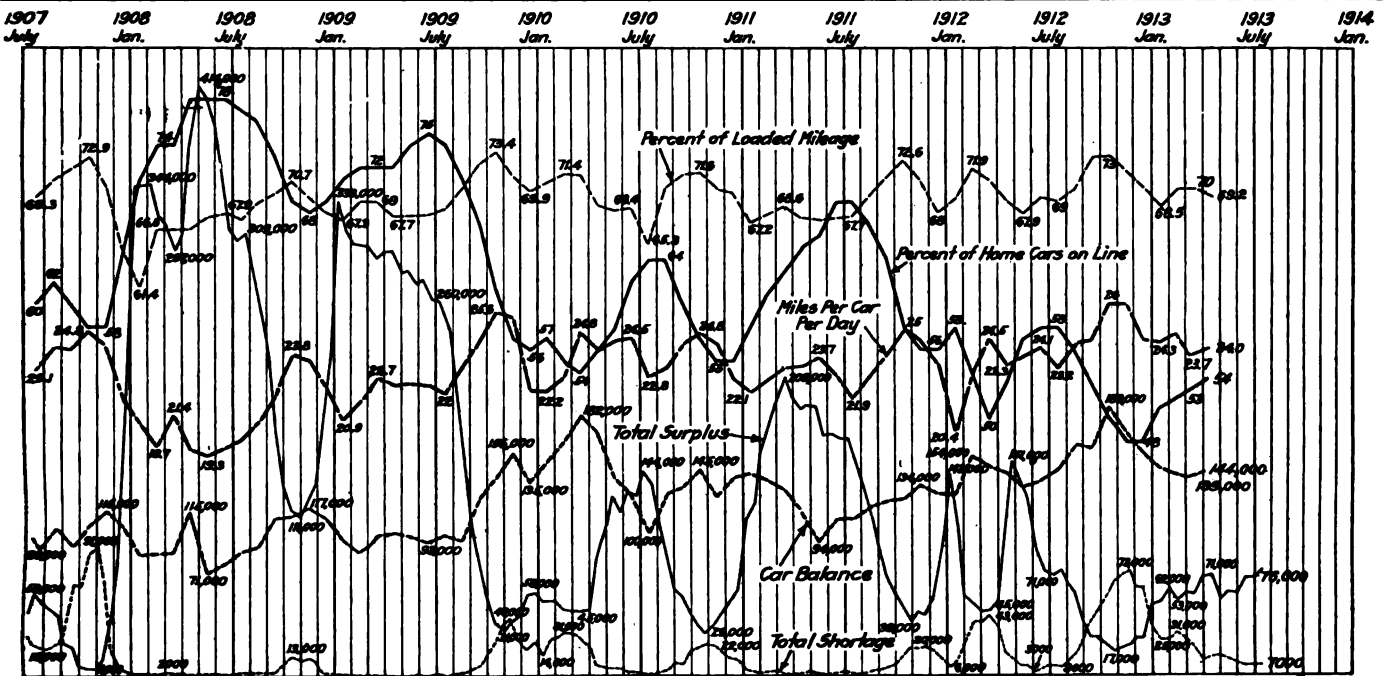

Freight Car Mileage, Earnings and Performance, 1907-1913.

REVENUES AND EXPENSES OF RAILWAYS.

MONTH OF JUNE, 1913.

Name of road.	Average mileage operated during period.	Operating revenues			Operating expenses			Net operating revenue (or deficit).	Outside operations, net.	Taxes.	Operating income (or loss).	Increase (or decrease) comp. with last year.
		Freight.	Passenger.	Total.	Way and structures.	Maintenance of equipment.	Traffic.					
Arizona, Eastern	367	\$165,696	\$41,266	\$223,210	\$103,361	\$30,647	\$3,252	\$59,435	\$9,584	\$206,276	\$1,794	\$5,180
Butte, Anaconda & Pacific	90	88,053	12,966	111,019	3,372	24,788	646	4,064	4,064	69,882	2,000	\$81,667
Carolina, Clinch, & Ohio Ry. Co. of S. C.	247	186,960	17,075	208,314	12,545	28,058	7,051	58,709	11,667	98,030	11,671	34,959
Chesapeake & Ohio Lines	2,333	3,213,996	534,779	3,060,498	530,207	372,191	58,884	971,735	63,128	1,996,145	1,807	39,225
Chicago, Rock Island & Pacific	7,573	3,351,882	1,667,572	6,137,476	854,932	770,816	158,136	2,145,651	131,945	4,061,480	237,962	1,831,866
Chicago, Terre Haute & Southeastern	351	122,578	16,270	142,800	20,286	20,286	3,290	55,898	9,290	112,904	10,000	5,358
Cincinnati, Hamilton & Dayton	1,015	678,526	140,047	931,268	117,027	163,894	20,518	440,843	19,757	762,077	40,757	84,899
Cincinnati, Northern	245	97,642	18,741	122,935	25,483	18,649	2,830	37,666	3,766	99,468	5,500	15,902
Cleveland, Cincinnati, Chic. & St. Louis	2,014	1,880,836	750,346	2,888,945	534,501	597,513	63,690	1,263,335	70,840	2,529,879	103,800	227,148
Colorado & Southern	1,127	541,262	125,835	686,992	107,441	174,427	13,571	213,277	21,703	530,419	29,175	125,639
Denver & Rio Grande	2,560	1,301,473	486,093	1,873,090	432,970	395,680	43,448	535,651	53,897	1,461,646	72,000	341,546
Denver & Salt Lake	215	66,051	37,975	108,713	20,948	18,533	5,295	29,701	5,784	86,261	3,762	22,690
Detroit & Toledo Shore Line	79	125,091	13,138	125,511	11,557	7,713	1,247	31,859	2,513	54,889	5,945	64,677
Detroit, Toledo & Ironton	441	112,583	13,138	125,511	42,957	100,372	2,443	75,329	5,811	226,912	5,935	95,429
Duluth & Iron Range	272	1,021,294	23,817	1,052,769	125,245	68,328	1,086	199,233	10,632	404,524	64,885	593,782
Duluth, South Shore & Atlantic	628	221,219	96,789	342,642	83,141	38,792	12,243	115,325	8,054	257,555	8,435	35,313
Galveston, Harrisburg & San Antonio	1,338	566,248	244,791	861,420	116,254	172,423	36,247	458,268	38,710	821,908	25,472	64,815
Gulf & Ship Island	308	131,969	35,228	180,725	21,329	34,646	3,159	54,488	8,313	121,935	9,136	32,226
Hoeking Valley	352	590,612	76,710	723,501	52,266	110,835	8,840	215,350	16,135	403,426	52,800	267,275
Illinois Central	4,763	3,519,279	1,104,450	5,312,982	534,218	1,203,857	105,225	1,860,014	122,744	3,827,058	256,301	1,227,304
Lehigh & Hudson River	97	133,229	3,905	171,665	31,511	19,247	1,504	65,780	4,207	122,249	4,067	45,349
Lehigh Valley	1,439	3,156,597	466,180	3,743,478	510,495	710,176	95,144	1,132,939	100,898	2,610,652	119,705	936,695
Louisiana & Arkansas	255	98,872	22,387	119,047	28,159	19,821	2,392	35,561	5,750	91,683	4,166	25,209
Louisiana Western	208	114,610	61,855	186,693	24,388	41,349	6,277	58,104	6,375	138,493	7,405	19,219
Midland Valley	373	67,570	40,580	116,610	32,996	33,297	2,670	41,666	5,670	116,299	6,205	5,870
Morgan's L. & Tex. R. & S. Co.	404	202,951	95,316	338,598	68,566	11,890	15,889	161,783	15,033	324,461	17,718	116,868
Nashville, Chattanooga & St. Louis	1,231	273,776	268,056	1,068,182	246,074	208,610	40,684	396,500	2,938	921,475	21,719	86,425
New Orleans & North Eastern	196	262,560	54,334	346,393	31,528	86,948	10,614	126,266	12,880	267,630	11,766	9,865
New Orleans, Mobile & Chicago	404	124,713	30,251	166,074	24,411	19,956	3,884	76,491	9,722	134,464	7,406	24,158
New Orleans, Texas & Mexico	286	73,902	16,138	96,301	5,944	39,210	3,411	54,099	7,214	97,990	1,436	3,125
New York, Ontario & Western	566	614,317	162,486	816,012	99,507	104,586	13,216	282,840	16,326	516,475	26,926	30,175
New York Central & Hudson River	3,750	5,663,380	3,287,891	9,962,558	1,604,197	1,846,126	191,009	3,405,463	287,453	7,335,142	536,788	2,091,751
New York, Susquehanna & Western	154	147,081	47,852	226,768	38,642	18,576	1,911	98,448	7,498	159,075	6,680	6,563
Norfolk & Western	2,035	3,199,476	415,319	3,742,889	492,067	747,211	60,939	1,172,031	71,435	2,543,683	122,000	1,092,408
Northwestern Pacific	401	115,079	215,966	352,850	51,619	39,504	4,646	119,885	13,402	229,056	12,866	110,928
Oregon Short Line	1,975	1,033,604	458,002	1,708,641	202,910	130,956	30,039	419,463	46,012	828,380	109,865	768,206
Oregon-Washington R. R. & Nav. Co.	1,917	893,114	502,002	1,491,550	253,453	166,257	49,544	472,346	53,980	995,580	363,242	99,111
Pecos & Northern Texas	482	124,658	37,098	172,774	22,413	38,666	3,539	65,020	7,984	136,762	2,450	33,562
Peoria & Eastern	352	197,172	59,800	291,724	65,046	45,450	4,241	113,608	6,802	235,147	10,400	46,177
Pere Marquette	2,330	861,628	322,127	1,309,768	396,483	273,797	38,263	524,770	39,830	1,273,143	32,764	23,909
Pittsburgh & Lake Erie	223	1,574,989	173,522	2,135,242	313,423	273,727	8,717	398,737	29,079	922,485	49,700	82,502
Pittsburgh, Shawmut & Northern	279	151,396	8,628	162,484	30,596	43,636	1,072	56,700	5,746	137,750	1,590	23,144
Rutland	468	175,232	104,822	323,455	45,430	75,200	10,559	123,458	8,096	262,243	16,613	44,599
St. Joseph & Grand Island	319	77,623	30,984	121,425	28,615	12,413	4,827	55,051	6,536	107,442	6,213	7,365
St. Louis & San Francisco	4,742	2,332,559	949,867	3,518,564	314,943	547,840	79,780	1,111,473	87,318	2,141,354	113,615	1,263,595
St. Louis, Brownsville & Mexico	518	113,848	72,514	166,362	41,973	41,973	6,373	111,485	9,434	211,257	5,500	10,437
St. Louis Merchants' Bridge Terminal	9	63,440	31,831	108,680	35,521	3,918	2,794	80,214	5,300	125,649	27,431	2,757
St. Louis, San Francisco & Texas	244	450,529	120,744	629,274	65,306	120,021	27,615	162,505	25,227	400,674	37,602	190,546
St. Louis Southwestern	906	556,294	287,026	941,180	119,180	273,521	34,641	583,741	19,166	1,273,143	43,899	312,677
San Pedro, Los Angeles & Salt Lake	1,135	707,373	146,678	900,410	210,111	210,111	2,096	307,798	3,854	581,415	7,318	29,509
Southern Kansas of Texas	125	87,776	30,103	134,225	29,171	13,008	5,508	45,212	6,281	98,972	4,318	2,667
Tennessee Central	294	2,260	2,260	330,565	31,001	10,239	8,868	86,257	31,323	135,750	25,560	1,106
Terminal R. R. Ass'n of St. Louis	34	246,254	102,315	371,216	93,580	61,862	8,868	153,544	13,028	335,902	13,136	3,559
Texas & New Orleans	458	246,254	102,315	371,216	93,580	61,862	8,868	153,544	13,028	335,902	13,136	3,559
Toledo & Ohio Central	443	513,646	55,044	601,866	85,795	92,854	6,863	182,768	10,246	378,526	24,335	197,892
Toledo, Peoria & Western	248	77,779	39,832	131,208	22,040	19,783	2,687	48,219	3,888	96,317	5,486	29,405
Toledo, St. Louis & Western	451	3,715,576	358,932	4,335,167	542,644	565,563	162,989	1,521,208	107,853	2,900,257	179,505	1,255,505
Trinity & Brazos Valley	463	85,168	42,990	136,071	85,509	37,754	10,274	90,084	10,077	233,698	4,000	101,627
Vicksburg, Shreveport & Pacific	171	67,242	46,225	124,366	21,863	29,010	3,814	45,459	4,978	103,526	6,500	12,847
Virginia & Southwestern	240	127,638	44,935	182,509	27,010	41,877	4,239	102,438	3,588	174,338	7,232	16,465
Virginian	503	425,507	47,100	485,813	87,663	77,663	10,499	110,499	8,747	260,695	20,800	36,139
Yazoo & Mississippi Valley	1,373	557,362	199,066	817,036	80,435	115,218	15,492	370,344	23,535	642,249	39,492	71,598

REVENUES AND EXPENSES OF RAILWAYS.

TWELVE MONTHS OF FISCAL YEAR, 1913.

Name of road.	Average mileage operated during period.	Operating revenues			Operating expenses			Net operating revenue (or deficit).	Outside operations, net.	Taxes.	Operating income (or loss).	Increase (or decr.) comp. with last year.		
		Freight.	Passenger.	Total, inc. misc.	Way and structures.	Maintenance of equipment.	Traffic.						Trans- portation.	General.
Arizona Eastern	367	\$2,076,266	\$467,849	\$2,692,035	\$431,136	\$235,535	\$31,875	\$679,786	\$102,172	\$1,480,504	\$1,211,531	\$115,937	\$1,096,578	\$258,630
Battle, Anzonia & Pacific	90	1,079,014	133,438	1,330,940	133,891	265,193	8,449	631,110	36,532	1,075,175	255,765	24,689	231,126	49,506
Butte, Clinchfield & Ohio	247	2,244,831	183,229	2,480,360	171,154	259,662	82,918	434,608	105,267	1,053,609	1,426,787	99,671	1,327,116	228,565
Carolina, Clinch & Ohio Ry. Co. of S. C.	18	132,589	18,874	154,239	10,671	1,049	11,845	32,366	7,090	65,021	89,218	7,307	81,911	6,021
Chesapeake & Ohio Lines	2,333	27,549,696	5,858,138	35,088,278	4,342,745	7,273,439	669,019	11,380,998	783,362	24,451,560	10,633,718	1,375,863	9,303,934	-1,341,096
Chicago, Rock Island & Pacific	7,573	43,940,946	19,080,164	67,968,961	9,509,079	9,715,722	1,874,979	27,539,337	1,677,461	50,316,578	17,652,383	2,857,693	14,611,279	487,837
Chicago, St. Paul, Minneapolis & Omaha	1,744	10,837,207	4,964,395	16,993,004	2,108,279	2,188,946	348,515	6,267,791	394,915	11,887,461	10,251,643	1,834,411	8,428,467	396,838
Chicago, Terre Haute & Southern	351	6,897,810	1,208,816	8,227,773	332,889	402,369	37,308	823,029	95,435	1,001,600	1,275,271	120,000	1,155,088	120,838
Cincinnati, Hamilton & Dayton	1,015	7,384,784	1,609,544	10,071,297	1,241,461	1,676,365	234,241	4,477,247	235,456	8,061,980	2,009,307	430,419	1,578,888	-531,506
Cincinnati, New Orleans & Texas Pacific	337	8,078,157	1,848,423	10,445,169	1,057,059	2,429,958	281,571	3,030,545	237,349	7,036,482	3,406,687	345,600	3,053,214	60,946
Cincinnati Northern	245	1,130,106	211,663	1,418,922	261,441	297,576	31,713	585,008	40,044	1,215,782	201,140	65,862	135,278	90,017
Cleveland, Cincinnati, Chic. & St. Louis	2,014	23,181,395	33,983,300	47,951,504	4,795,550	6,785,848	862,527	13,708,573	706,502	26,859,000	7,124,300	1,243,042	5,667,891	-97,968
Colorado & Southern	1,127	6,897,810	1,395,362	8,827,773	1,166,653	2,010,570	135,829	2,624,703	265,979	6,203,734	2,624,039	351,258	2,257,620	83,091
Colorado Midland	338	1,401,428	262,763	1,828,335	270,463	409,896	92,095	817,027	68,348	1,657,829	1,701,506	95,477	70,596	-108,080
Cumberland Valley	162	2,671,527	692,191	3,521,447	620,193	419,384	53,299	1,163,646	98,854	2,355,376	1,166,071	71,240	1,095,981	184,010
Delaware & Hudson Co.—R. R. Dept.	854	20,104,347	3,091,853	23,999,532	1,864,867	3,590,932	281,697	8,212,929	706,265	14,656,690	9,342,842	602,713	8,667,536	954,105
Delaware, Lackawanna & Western	958	29,618,439	8,167,527	40,518,044	5,043,138	6,145,292	837,899	12,458,433	798,469	25,283,231	15,234,813	1,748,340	14,068,848	3,133,758
Denver & Rio Grande	2,560	18,078,140	5,299,081	24,452,965	3,545,938	4,538,251	546,433	7,738,496	678,055	17,047,172	7,405,793	948,739	6,450,559	1,054,300
Denver & Salt Lake	215	808,790	296,390	1,156,952	201,077	205,246	28,906	392,147	60,948	888,334	688,628	42,262	226,366	-28,024
Detroit & Mackinac	418	818,460	339,835	1,242,327	166,415	174,768	26,969	443,602	34,942	846,696	395,631	103,519	288,818	45,960
Detroit & Toledo Shore Line	79	1,349,364	.....	1,354,559	145,378	76,065	14,739	375,048	28,425	639,655	714,904	66,755	648,149	63,885
Detroit River Tunnel	.....	.....	.....	1,285,488	28,213	34,618	.....	106,918	981	1,707,300	1,114,750	61,508	1,043,250	45,061
Detroit, Toledo & Ironton	441	1,391,374	151,770	1,673,286	422,046	469,201	31,723	859,468	64,395	1,846,831	1,734,541	68,869	2,421,414	362,627
Duluth & Iron Range	272	6,750,768	263,164	7,121,719	891,543	679,920	11,601	1,597,448	143,596	3,324,108	3,797,611	26,233	3,461,883	117,821
Duluth, Missabe & Northern	356	7,946,030	442,283	8,476,104	967,089	979,656	25,007	1,676,713	154,893	3,803,358	4,672,746	29,095	4,278,575	549,884
Duluth, South Shore & Atlantic	628	2,252,869	972,528	3,415,832	716,712	1,161,864	119,642	1,358,579	117,693	2,724,490	688,342	19,625	473,389	-99,866
El Paso & Southwestern	982	7,126,209	1,151,938	8,657,731	1,039,279	1,161,259	175,735	2,420,320	321,625	5,118,283	3,539,433	378,952	3,126,828	348,954
Elgin, Joliet & Eastern	824	12,385,212	1,415,968	13,801,782	1,415,968	2,051,942	60,341	1,771,064	212,180	7,511,495	8,539,238	404,905	5,434,382	1,140,232
Eric	1,988	40,120,601	9,473,473	49,594,074	5,372,831	9,619,241	1,201,739	18,058,645	1,126,909	35,379,385	18,952,428	1,768,399	16,509,733	2,961,819
Florida East Coast	642	2,452,214	1,914,798	3,037,056	770,841	706,791	92,189	1,837,546	147,436	3,554,003	1,482,453	214,519	1,252,673	129,379
Fort Worth & Denver City	454	3,510,915	1,564,159	5,334,556	598,395	981,926	84,727	1,906,263	174,624	3,745,405	1,589,151	128,920	1,450,588	-20,584
Galveston, Harrisburg & San Antonio	1,338	8,291,538	3,200,942	12,065,517	1,308,723	2,470,656	409,846	5,003,150	377,161	9,370,566	2,493,981	268,085	2,980,269	283,521
Grand Rapids & Indiana	378	3,291,036	1,786,971	5,019,074	777,463	919,817	139,532	2,343,324	190,195	4,570,062	1,439,012	265,084	864,534	1,350
Great Northern	7,752	58,426,236	15,158,588	78,654,591	12,321,241	9,361,317	1,242,553	21,473,258	1,430,291	45,828,640	32,825,951	4,276,898	28,670,376	3,491,235
Gulf & Ship Island	308	1,548,699	411,903	2,110,542	285,671	376,939	34,158	563,591	99,639	1,359,998	750,544	.....	663,260	96,914
Gulf, Colorado & Santa Fe	1,596	9,863,758	2,993,363	13,701,533	2,418,285	2,129,057	299,985	5,207,818	410,851	10,195,996	3,505,537	469,628	3,035,909	733,514
Hocking Valley	352	6,365,735	929,991	7,817,644	781,109	1,595,266	106,384	2,332,475	168,609	4,983,843	2,833,801	477,900	2,355,901	45,452
Illinois Central	4,763	42,589,299	13,455,884	64,280,903	8,519,025	13,952,654	1,320,583	24,743,324	1,513,325	50,048,911	14,231,992	2,903,551	11,250,848	3,438,129
Indiana Harbor Belt	105	.....	.....	389,744	389,744	387,268	32,026	1,422,550	81,335	2,314,923	917,302	66,554	872,214	186,947
International & Great Northern	1,160	8,074,686	2,464,156	11,260,565	1,472,197	1,557,565	319,664	4,796,525	383,529	8,527,480	2,733,085	340,000	2,372,072	.....
Kanawha & Michigan	177	2,858,751	372,311	3,303,229	478,269	641,445	28,823	958,671	78,211	1,185,419	1,117,810	106,262	1,011,488	-15,573
Kansas City Southern	827	7,955,386	1,694,580	10,706,309	1,024,840	1,344,625	315,868	3,661,311	400,513	6,747,157	3,959,152	465,339	3,493,813	964,162
Lake Erie & Western	906	4,843,415	888,375	6,062,327	894,907	1,138,283	143,302	2,315,277	141,100	4,632,819	1,429,508	247,269	1,182,239	158,620
Lake Shore & Michigan Southern	1,872	39,376,127	12,504,785	58,272,052	7,148,005	10,363,122	1,020,739	18,965,468	1,046,288	38,543,617	19,728,435	1,831,098	18,069,373	1,770,859
Lehigh & Hudson River	97	1,712,366	47,563	1,849,439	238,945	261,941	16,023	623,859	52,840	1,242,608	606,828	48,067	558,761	44,334
Lehigh Valley	1,439	36,725,138	4,867,554	43,043,372	5,694,422	7,561,271	982,858	13,993,617	875,652	29,107,820	13,935,552	1,447,205	12,208,137	1,625,703
Long Island	399	3,462,813	755,985	11,641,883	1,555,766	1,320,191	170,288	5,010,386	301,397	8,358,028	3,283,855	717,822	3,080,900	310,251
Louisiana & Arkansas	255	1,375,538	243,981	1,674,459	270,644	254,707	60,207	1,059,718	613,741	1,425,428	666,396	50,235	563,506	76,066
Louisiana Ry. & Navigation	351	1,476,056	291,604	1,891,824	279,162	241,866	71,423	753,999	78,978	1,425,428	466,396	59,505	406,891	57
Louisiana Western	208	1,501,219	708,520	2,315,374	281,762	424,196	88,384	709,848	88,866	1,573,056	742,318	90,653	652,633	190,382
Louisville, Henderson & St. Louis	200	775,422	171,884	1,231,481	304,931	165,858	52,653	467,972	38,000	1,029,414	202,068	43,348	161,837	-99,230
Maine Central	1,006	7,126,071	3,511,171	11,331,406	1,792,298	1,646,818	132,519	4,330,613	345,150	8,246,998	3,084,408	548,621	2,495,393	72,784
Michigan Central	1,817	23,018,013	8,795,392	35,379,498	4,199,116	5,170,762	801,007	14,110,794	624,524	24,906,203	10,473,295	1,366,985	9,123,561	570,326
Midland Valley	373	951,078	479,056	1,511,166	375,462	279,158	31,415	511,379	69,019	1,266,433	244,733	71,840	181,430	-82,258
Minneapolis & St. Louis	1,886	7,283,061	1,865,938	9,707,004	1,249,821	1,208,665	215,727	3,784,632	248,273	6,707,398	2,909,616	382,242	2,617,011	1,173,709
Minneapolis, St. Paul & Sault Ste. Marie	3,976	23,485,675	6,598,443	31,763,916	3,486,089	3,978,876	647,035	10,996,353	685,782	18,891,257	12,872,530	1,764,124	11,236,024	2,316,991
Missouri, Kansas & Texas System	3,871	20,912,978	9,402,967	32,346,258	4,637,748	4,100								



Dermott, Ark., to New Orleans, La., when for export, was not unreasonable. (28 I. C. C., 215.)

#### Rates on Cotton Piece Goods Reduced.

*John Taylor Dry Goods Company et al, v. Missouri Pacific et al. Opinion by Commissioner Prouty:*

The complainants ask for a carload rating upon cotton piece goods originating in New England and the south for the transportation from points on the Mississippi river to points on the Missouri river. The commission decided that to establish a carload rating here and not elsewhere would be to throw out of balance the relation between rates on this important commodity in all parts of the country. There are good reasons why cotton piece goods should be given a carload rating, but if this is to be done it should be in some more comprehensive way than by an order in the present proceeding. The prayer was denied.

The present any-quantity rate of 35 cents per 100 lbs. upon cotton piece goods originating in New England and the south for the transportation from points on the Mississippi river to points on the Missouri river is unjust and unreasonable to the extent that it exceeds 32 cents.

Rates on cotton piece goods to Sioux City, Iowa, from Southern mills seem to be somewhat higher than those to other points upon the Missouri river. The same reduction should be made to Sioux City in all cases as is made to other Missouri River points.

Reparation should be awarded complainants in amount of the difference between the 35-cent rate and the 32-cent rate on their shipments of cotton piece goods since December 31, 1911, only, the date of the commission's decision in the *Warnock case*, 21 I. C. C., 546.

The complainants contend that, under the tariff of October 26, 1910, they are entitled to reparation in the amount of the difference paid under the 35-cent rate and the 30-cent rate, but that contention is denied, because the claim is not based upon the reasonableness of the rate charged. It involves simply a question of tariff construction. *Wheeler & Motter case*, 20 I. C. C., 141, cited and followed. (28 I. C. C., 205.)

#### STATE COMMISSIONS.

C. C. Witt, for the past two years engineer for the Public Utilities Commission of Kansas, has resigned to accept a position with the Interstate Commerce Commission. T. J. Strickler succeeds Mr. Witt.

The new Public Service Commission of Pennsylvania, the establishment of which was noticed last week, has appointed John P. Dohoney investigator of accidents, and George A. Woods, marshal. The commission has already taken up some of the unfinished business in the office of the former railroad commission, and has issued a decision in a car demurrage case; but no other permanent appointments have thus far been made.

The governor of Maine has issued a proclamation declaring that the general election to decide on the public utilities act of the state will not be held until September, 1914; which means that the present railroad commission of Maine will continue until that time. In the proclamation Gov. Haines emphasizes what he considers the good points of the law, and urges the people of the state to give it their soundest and best consideration before voting it down.

**UNION STATION FOR DELHI, INDIA.**—The government of India has issued the reports of the Delhi town-planning experts. Dealing with communications the committee discusses the question of railways, roads and tramways, and is of opinion that a complete scheme of railway arrangements, designed to serve the whole of the capital, both old and new, should be an essential feature of the layout of the city. The scheme as now drawn out provides for a new union station into which it will be possible to run every passenger train which will arrive at Delhi, whether on the 5 ft. 6 in. gage or the 3 ft. 3 in. gage. By no other means, except by such a terminal arrangement, is it possible to give to Delhi as a whole the important advantage of a central station from which all trains will depart. The scheme also provides for a short diversion of the existing Agra-Delhi chord line. This will be necessary to enable the Great Indian Peninsula and Bombay, Baroda & Central India to run into the station.

## Railway Officers.

#### Executive, Financial and Legal Officers.

James M. Buick, secretary of the Sligo & Eastern, has been chosen president, with headquarters at St. Louis, Mo., succeeding Charles L. Rogers.

E. W. Peabody has been appointed statistician, in charge of the statistical bureau of the Missouri, Kansas & Texas, with headquarters at St. Louis, Mo.

Y. C. Campbell has been appointed claims agent of the Intercolonial Railway and the Prince Edwards Island Railway for the district from Halifax, N. S., to Sydney, with headquarters at New Glasgow, N. S.

Walter C. Noyes has been appointed general counsel of the Delaware & Hudson, with office at New York, succeeding Wm. S. Opdyke, resigned. Mr. Opdyke continues his connection with the company as a member of the board of managers.

The Colorado, Kansas & Oklahoma is the new name of the Scott City Northern, which has been reorganized with general office at Scott City, Kan. The officers of the new company are now as follows: William C. Fordyce, president, St. Louis, Mo.; Frank S. Yantis, vice-president, general manager and treasurer, Scott City, Kan.; Edward F. Goltra, vice-president, St. Louis; W. V. Delahunt, secretary, St. Louis; Wm. G. Little, assistant secretary, auditor and traffic manager, Scott City; R. L. Gurney, assistant treasurer, St. Louis, and Lee Monroe, general counsel, Topeka, Kan. The other officers retain their former positions with the reorganized company.

#### Operating Officers.

F. C. Dow has been appointed trainmaster of the Musselshell division of the Chicago, Milwaukee & St. Paul, with office at Miles City, Mont., succeeding A. C. Bowen, transferred.

C. E. Brooks, assistant superintendent of the Idaho division of the Oregon Short Line, has been transferred to the Montana division as an assistant superintendent, with headquarters at Pocatello, Idaho, succeeding G. L. Hickey, resigned.

W. F. Kaderly is general superintendent of both the Georgia Southern & Florida, and the Hawkinsville & Florida Southern, with office at Macon, Ga.; and he retains his position as superintendent of motive power of the Macon & Birmingham.

C. L. Titus, trainmaster of the New York, Chicago & St. Louis at Ft. Wayne, Ind., has been appointed assistant superintendent of the Buffalo division, with office at Conneaut, Ohio. O. Pierce succeeds Mr. Titus as trainmaster of the Chicago division. Effective August 15.

The Pere Marquette announces that hereafter the railroad will be divided into two districts, to be known as the Western district, with headquarters at Grand Rapids, Mich., and the Eastern district, with headquarters at Saginaw, Mich. The Western district will comprise the Chicago, the Petoskey and the Detroit divisions; J. A. Gordon is appointed general superintendent of that district, with office at Grand Rapids. The Eastern district will include the Toledo, the Port Huron, and the Canadian divisions, and W. C. Hurst is appointed general superintendent, with office at Saginaw. Effective August 11.

#### Traffic Officers.

Stanton Curtis, northwest passenger agent of the Southern Railway at Chicago, has been appointed assistant general passenger agent, with office at Chicago, effective September 1.

H. Brandt, district passenger agent of the Pacific Coast Steamship Company, with office at Los Angeles, Cal., has been appointed general agent, passenger department, with office at Seattle, Wash., succeeding George W. Andrews, assigned to other duties, and H. B. Brittain, city passenger agent at Los Angeles, Cal., succeeds Mr. Brandt.

C. H. Webb has been appointed assistant general freight agent of the South Texas and Louisiana lines of the St. Louis & San Francisco, embracing the St. Louis, Brownsville & Mexico, the Beaumont, Sour Lake & Western, the Oregon & N. W. western, and the New Orleans, Texas & Mexico, with headquarters at Houston, Tex.

Warner Winston Croxton, who has been appointed general passenger agent of the Atlanta, Birmingham & Atlantic, with headquarters at Atlanta, Ga., as has been announced in these columns, was born on August 25, 1880, in King William county, Virginia, and was educated in the high schools. He began railway work on June 1, 1900, with the Southern Railway, and from January of the following year to July 1902, was stenographer at Columbia, S. C. He was then for four months at Richmond, Va., and from December, 1902, to April, 1904, was secretary to the general passenger agent of the same road at Washington, D. C. From April, 1904, to October, 1905, he was traveling passenger agent of the same road at Norfolk, Va., and was then transferred in the same capacity to New York, where he remained until April, 1907, when he returned as traveling passenger agent to Norfolk, and in September, 1908, was again transferred in the same capacity to Baltimore, Md. He was appointed assistant general passenger agent of the Norfolk Southern with headquarters at Norfolk in September, 1909, and one year later was promoted to general passenger agent, which position he held at the time of his recent appointment as general passenger agent of the Atlanta, Birmingham & Atlantic, as above noted.

W. I. Jones, who on August 1 was appointed assistant to the general traffic manager of the Missouri Pacific and St. Louis, Iron Mountain & Southern, with headquarters at St. Louis, Mo.,



W. I. Jones.

began railway work in 1886 as a locomotive fireman on the Iron Mountain. He was employed in that capacity until October, 1888, when he was transferred to the local office of the Missouri Pacific, and after remaining there about 15 months went to the traffic department. He left railway work in May, 1891, returning in March, 1901, as chief clerk to the assistant general freight agent of the Missouri Pacific. In November, 1906, he was promoted to commercial agent at Monroe, La., returning to the general office as chief clerk to the freight traffic manager on November 1, 1907. Mr. Jones was made assistant general freight agent in December, 1910, which position he held when recently promoted to assistant to the general traffic manager, as above noted. Mr. Jones' entire railway service has been with the Missouri Pacific system.

**Engineering and Rolling Stock Officers.**

J. E. McQuillen, master mechanic of the Gulf, Colorado & Santa Fe at Silsbee, Tex., has been appointed mechanical superintendent, with headquarters at Cleburne, Tex., succeeding P. T. Dunlop, resigned.

G. A. Schmoll, district superintendent of motive power of the Baltimore & Ohio, at Wheeling, W. Va., has been appointed district superintendent of motive power, with headquarters at Pittsburgh, Pa., succeeding E. J. Searles, resigned, and J. F. Bowden, master mechanic at Newark, Ohio, succeeds Mr. Schmoll. A sketch of Mr. Bowden's career was published in the *Railway Age Gazette* of May 16, 1913, page 1111.

G. A. Schmoll, who has been appointed district superintendent of motive power of the Baltimore & Ohio, with headquarters at Pittsburgh, Pa., was born on November 23, 1862, at Fort Wayne, Ind., and began railway work in June, 1885, as an apprentice in the shops of the Pennsylvania Railroad. He later became machinist and in January, 1902, was made shop foreman, leaving that company the following November to become motive power inspector on the Baltimore & Ohio. In June, 1903, he was promoted to master mechanic at Mount Clare, and seven years

later he became superintendent of motive power at Wheeling, W. Va., remaining in that position until his appointment as district superintendent of motive power at the same place, which position he held at the time of his recent appointment as district superintendent of motive power at Pittsburgh, as above noted.

J. L. Cunningham, whose appointment as master mechanic of the Philadelphia, Baltimore & Washington, with headquarters at Wilmington, Del., has already been announced in these columns, was born on September 28, 1874, at West Fairfield, Pa., and in 1891 graduated from Blairsville, Pa., High School. In November of the same year he became machinist apprentice on the Pennsylvania Railroad at Altoona, Pa., and after completing his apprenticeship, entered Purdue University, graduating with the class of 1900. In July of the same year he was appointed motive power inspector on the Pennsylvania Railroad at Philadelphia, Pa., and the following March was transferred in the same capacity to Pittsburgh. In December, 1902, he was made foreman of the Bedford division shops, at State Line, Pa., and one year later became assistant master mechanic at Harrisburg. He was appointed general foreman at Columbia, Pa., in October, 1904, and in April, 1906, was made assistant engineer of motive power at Williamsport, Pa., becoming master mechanic of the New York, Philadelphia & Norfolk in August, 1910, with headquarters at Cape Charles, Va., which position he held at the time of his appointment on July 1, as master mechanic of the Philadelphia, Baltimore & Washington, as above noted.



J. L. Cunningham.

**Purchasing Officers.**

H. G. Cook, whose appointment as general storekeeper of the Southern Pacific, with headquarters at San Francisco, Cal., has already been announced in these columns, began railway work, January 1, 1901, as storekeeper and round-house clerk for the Chicago, Rock Island & Pacific at Phillipsburg, Kan. Two years later he was transferred to Horton, Kan., where he was successively accountant, stock clerk and chief clerk in the office of the district storekeeper, until the early part of 1905. During the two years following he was employed as chief clerk in the office of the superintendent of motive power at Topeka, Kan., and again as chief clerk to the district storekeeper at Horton, leaving the Rock Island in February, 1907, to accept the position of inspector of stores with the Southern Pacific. He served in that capacity for three years and was then appointed storekeeper at Los Angeles, Cal., in February, 1910, being transferred to Sacramento, Cal., in April, 1911, to take charge of the general stores at that point. He held the latter position until his appointment on July 15 as general storekeeper, as above noted.



H. G. Cook.

of stores with the Southern Pacific. He served in that capacity for three years and was then appointed storekeeper at Los Angeles, Cal., in February, 1910, being transferred to Sacramento, Cal., in April, 1911, to take charge of the general stores at that point. He held the latter position until his appointment on July 15 as general storekeeper, as above noted.

## Equipment and Supplies.

### LOCOMOTIVE BUILDING.

THE SAN ANTONIO & ARANSAS PASS has ordered 8 consolidation locomotives from the Baldwin Locomotive Works.

THE SANDY RIVER & RANGELEY LAKES has ordered 1 six-wheel switching locomotive from the Baldwin Locomotive Works.

THE HOCKING VALLEY has ordered 6 mikado locomotives and 2 ten-wheel locomotives from the American Locomotive Company.

THE ERIE has ordered 40 mikado locomotives from the American Locomotive Company, and 10 Pacific type locomotives from the Baldwin Locomotive Works.

THE NIGERIAN RAILWAYS OF AFRICA have ordered 2 six-wheel switching locomotives from the American Locomotive Company. The dimensions of the cylinders will be 14 in. x 24 in., and the diameter of the driving wheels will be 44 in., and the total weight in working order will be 71,000 lbs.

### CAR BUILDING.

THE NEW YORK CENTRAL LINES, mentioned in the *Railway Age Gazette* of August 1, as being in the market for about 300 passenger cars, are now definitely in the market for 204 passenger cars.

THE SOUTHERN RAILWAY has ordered 800 gondola cars and 500 box cars from the American Car & Foundry Company, and 420 gondola cars from the Mt. Vernon Car & Manufacturing Company.

### IRON AND STEEL.

THE CHICAGO, MILWAUKEE & ST. PAUL is inquiring for 70,000 tons of rails.

THE CHICAGO, BURLINGTON & QUINCY is inquiring for 50,000 tons of rails.

THE ATCHISON, TOPEKA & SANTA FE is inquiring for 30,000 tons of rails.

GENERAL CONDITIONS IN STEEL.—During the past two weeks the orders received by the Steel Corporation have shown a considerable increase over the previous week. New orders are running at present at about 60 per cent. of shipments, or 10 per cent. better than three weeks ago. The railroads are beginning to enter the market again and it is expected that the orders for equipment will show a material increase in the near future.

### SIGNALING.

The Pennsylvania Railroad is to install automatic block signals on its main line, Middle division, from Iroquois to Lewiston Junction, 40 miles.

The Western Maryland has given a contract to the Union Switch & Signal Company for the installation of automatic block signals on its lines through five tunnels, between Hagerstown and Cumberland, Md., and at other points on that division, aggregating 15½ miles of track.

The Baltimore & Ohio has put into operation the automatic signals which have been under construction during the past few months between McCools and La Paz, on the Chicago division of the road, 45 miles. Automatic block signals are being installed on the Cincinnati, Hamilton & Dayton, between Glenwood and Indianapolis, 48 miles, and on the Baltimore & Ohio Southwestern, between North Vernon, Ind., and Milan, 30 miles.

FUEL OIL IN ROUMANIA.—A few locomotives were converted into oil burners as long ago as 1887. In 1911, out of a total of 595 locomotives, 499 used oil for fuel. About five-eighths of the fuel is petroleum, one-eighth is coal from Cardiff and Westphalia, more than a seventh lignite, and one-tenth wood.

## Supply Trade News.

William G. Bee, formerly manager of sales of the Edison Storage Battery Company, Orange, N. J., has been made a vice-president and general sales manager of that company.

The Roberts & Schaefer Company, Chicago, has received a contract from the Grand Trunk to build a 600-ton, Holmen, coal-ign station at St. Lambert, Que. The contract price is about \$17,000.

C. R. Weaver has been made vice-president of the L. J. Bordo Company, Philadelphia, Pa., maker of Bordo blow-off valves, succeeding C. W. Allen, resigned. Mr. Allen has also resigned his position as a director of this company.

The Indiana Car & Equipment Company has recently opened a new plant at East Chicago, Ind., for building and repairing freight cars. P. H. Joyce, who is also president of the Illinois Car & Manufacturing Company, is president and treasurer of the new company, and L. J. Smith is secretary. The general offices are in the Great Northern building, Chicago.

The Stark Rolling Mill Company, Canton, Ohio, has appointed The Pedlar People, Ltd., Oshawa, Ont., its general distributors of Toncan metal sheets and products in Canada. The Pedlar People have branches at Montreal, Toronto and Winnipeg. A. T. Enlow, formerly sales manager of the Stark Rolling Mill Company, has been made manager of sales and a director of The Pedlar People, Ltd., and is also a director.

Alfred A. Pope, president of the National Malleable Castings Company, Cleveland, Ohio, died at his summer home in Farmington, Conn., on August 5. Mr. Pope was born in North



Alfred A. Pope.

Vassalboro, Me., in 1842. When he was a boy his family moved to Salem, Ohio, where he received his schooling. After several years the family moved to Cleveland, Ohio, where Mr. Pope started in business. After five or six years as a partner in the woolen manufacturing business conducted by his father and brothers under the firm name of Alton Pope & Sons, his connection with the malleable iron business began in the year 1869. This became the leading commercial interest of his life and he, associated with his partners, was foremost in developing the present process of making malleable iron and in extending its manufacture until now it has become one of the most important iron industries in the United States. Under his leadership the Cleveland Malleable Iron Company grew rapidly, until it finally became the National Malleable Castings Company. The Eberhard Manufacturing Company, Cleveland, established by Mr. Pope in 1879, was expected to produce light and special castings, but has developed into one of the largest manufacturers of vehicle and saddlery hardware in the country. The Ewart Manufacturing Company, Chicago, now a part of the Link-Belt Company, originators of detachable link belting, is another of the large enterprises which grew under the management of Mr. Pope. At the time of his death, Mr. Pope was president of the National Malleable Castings Company and the Eberhard Manufacturing Company, which positions he held since the organization of those companies. He was a director in the Link-Belt Company, the North & Judd Manufacturing Company, and the Landers, Frary & Clark Company, New Britain, Conn., the Indiana & Michigan Electric Company, South Bend, Ind., the Colonial Trust Company of Waterbury, Conn., and the Century Bank of New York.

## Railway Construction.

**ALTON & SOUTHERN.**—Incorporated in Illinois with \$10,000 capital, to build from a point opposite St. Louis, Mo., to a point at or near the banks of the Mississippi river in Madison county, Ill. The line is being built by the Aluminum Company of America, Pittsburgh, Pa., and it is said that about six miles have been completed. The incorporators include C. B. Fox, C. E. Hodgson and W. H. Hebenstreit, all of East St. Louis, Ill.

**ANACORTES & EASTERN.**—An officer writes that contracts are to be let soon to build the first section of a line from Anacortes, Wash., southeast to Laconner, thence northeast via Mount Vernon to Avon. There will be a 6,000 ft. trestle and one wooden drawbridge with a 75 ft. opening. A. D. Bower, president, and H. W. Griswold, chief engineer, Anacortes.

**ATCHISON, TOPEKA & SANTA FE.**—The Dodge City & Cimarron Valley has been extended from Hugoton, Kan., west to Elkhart, 33 miles. (March 14, p. 528.)

**BRINSON RAILWAY.**—This road has been extended from Waynesboro, Ga., northwest to St. Clair, 13 miles. (November 22, p. 1013.)

**BUCTOUCHE RAILWAY & TRANSPORTATION.**—The Minister of Railways for Canada has approved the location plan for the projected extension from Richibucto to Loggieville, N. B., 47 miles; but has refused to approve the plans for a line from Painsee Junction to Cape Tormentine, N. B., 42 miles. (Jan. 10, p. 87.)

**BUTTE-BOISE-WINNEMUCCA.**—An officer of this company, which was recently organized in Idaho with \$40,000,000 capital to build a line east and west from Boise, Idaho, writes that preliminary lines have been run between Anaconda, Mont., and Winnemucca, Nev., and a section of the line near Boise, Idaho, has been finally located. The company expects to do considerable work on the line this fall. L. O. Leonard, president, Boise. (July 18, p. 131.)

**CANADIAN PACIFIC.**—A new line called the Kootenay subdivision has been opened for business on the British Columbia division, from Golden, B. C., south to Spillimacheen, 40 miles.

**CHICAGO, MILWAUKEE & ST. PAUL.**—According to press reports, a contract has been given to the Keasal Construction Company, Tacoma, Wash., for work on the first two sections of 13 miles of the Puget Sound & Willapa Harbor, from Willapa Harbor northeast to Helsing Junction, about 47 miles. (April 25, p. 974.)

**COLORADO, KANSAS & OKLAHOMA.**—An officer writes that this company, formerly the Scott City Northern, expects to begin work early in October on the extension from Scott City, Kan., via Dodge City and Kinsley, to Wichita, where a connection is to be made with the Midland Valley. (August 1, p. 211.)

**FRONTIER ELECTRIC.**—An officer writes that this company has been organized to build an electric line on a private right of way between Niagara Falls, N. Y., and Buffalo. The necessary franchises have been secured from the city of Niagara Falls, also from North Tonawanda and Tonawanda. Nearly all the right of way has been secured and as soon as the entire right of way is secured construction work will be started. J. S. Simmons, Niagara Falls, may be addressed.

**GREAT NORTHERN.**—See Kettle Valley.

**KETTLE VALLEY.**—A contract has been given to MacArthur Brothers Company, New York, for building 38 miles of railroad in the Coquehalla canyon, B. C., to be used jointly by the Kettle Valley and the Great Northern. The work will cost over \$2,000,000, and consists of considerable heavy rock work with several small tunnels. Some of the work will be sublet at once by F. C. Hitchcock, vice-president and general manager of MacArthur Brothers Company, with headquarters at Hope, B. C. (August 1, p. 211.)

**LITTLE ROCK, PINE BLUFF & EASTERN TRACTION.**—An officer writes regarding the construction of a line from Little Rock, Ark., southeast to Pine Bluff, 50 miles, that the company is now negotiating for franchises, also for terminal facilities, and that construction work will not be started until these matters are

satisfactorily arranged. The line is to have maximum grades of 13 ft. to the mile, and over 94 per cent. of the track will be straight. E. W. Jackson, vice-president and chief engineer, Little Rock.

**MINNESOTA CENTRAL (Electric).**—Incorporated with \$1,000,000 capital to build from Minneapolis, Minn., northwest via Robbinsdale and Champlin, to St. Cloud, about 80 miles. The line may eventually be extended north to Mille Lacs. A contract for grading the section from Robbinsdale to Champlin has been given to Petris & Smith, Osseo. E. G. Potter, president, Minneapolis; E. M. Nye, secretary, and E. M. Potter, treasurer.

**MINNEAPOLIS, ST. PAUL & SAULT STE. MARIE.**—The new line called the Sixth district has been opened for business on the Winnipeg division, from Fordville, N. D., west to Drake, 131.9 miles. (November 29, p. 1063.)

**MONTEZUMA SAN JUAN SOUTHERN.**—An officer of this company, which was organized recently in Colorado, to build via Cortez, Colo., south, to Fruitland, N. Mex., thence to Grants, about 200 miles, writes that arrangements have been made with the Ute Construction Company, St. Louis, Mo., to carry out the work. E. P. Allen, managing director of that company, will sublet the construction work. W. K. Palmer, of the Palmer Engineering Company, Kansas City, Mo., is in charge of the engineering work. G. O. Harrison, president, and Emil Stein, general manager, Cortez. (May 23, p. 1161.)

**MONTOUR RAILROAD.**—An officer of this company, which is a subsidiary of the Pittsburgh Coal Company, Pittsburgh, Pa., writes that work is now under way on an extension to Mingo Junction, where a connection is to be made with the Bessemer & Lake Erie, about 35 miles. (March 14, p. 529.)

**NACOGDOCHES & SOUTHEASTERN.**—An officer writes that the company expects to have work finished by October on the short extension of about three miles from the present eastern terminus at Dunham, Tex., east to a connection with the Angelina & Neches River, at a point about five miles west of Chireno. (March 14, p. 529.)

**NEBRASKA ROADS.**—According to press reports plans are being made by capitalists of Nebraska to build from Northport, Neb., southwest via Banner county, to the Pinebluff section of Wyoming. C. W. Perry, Pinebluff, Wyo., is said to be interested.

**OKLAHOMA, NEW MEXICO & PACIFIC.**—According to press reports, this company has given the Kenefick Construction Company the contract to build 25 miles of line westerly from Ardmore, Okla. Construction work is now under way. The old right of way of the Arkansas & Choctaw has been acquired and the first 20 miles will be easily and quickly built, as the majority of the grading has already been done. Ties and rails have been purchased and are now arriving. The main office of the company will be located at Ardmore.

**ORANGEBURG RAILWAY.**—This road has been completed from a connection with the Seaboard Air Line at North, S. C., southeast via Wolfton, and Raymond, to Orangeburg, which is on the Atlantic Coast Line and the Southern Railway, 17 miles, and is now open for traffic.

**PENNSYLVANIA SOUTHERN.**—This company will rebuild 16½ miles of line in Clarion county, Pa., and build two short branches to new coal mines. The Millcreek division will also be rehabilitated and car shops established at Clarion. The improvements will cost upwards of \$200,000.

**PUGET SOUND & WILLAPA HARBOR.**—See Chicago, Milwaukee & St. Paul.

**SAN ANTONIO, UVALDE & GULF.**—The Gulf division has been extended from Kitty, Tex., south to Mikaska, 13 miles. (July 18, p. 132.)

### RAILWAY STRUCTURES.

**BROWNWOOD, TEX.**—The Gulf, Colorado & Santa Fe has awarded a contract for the erection of new terminal buildings at this point, including a 12-stall roundhouse.

**CLARION, PA.**—See Pennsylvania Southern under Railway Construction.

**NEW LONDON, CONN.**—Preliminary borings for the new four-track bridge which the New York, New Haven & Hartford is to build over the Thames river at New London are now under way and it is expected that they will be completed in about three months, when the final plans, based on the results of such borings, will be drawn. This will take possibly another six months. Like the Connecticut river bridge, the piers will be four-track piers, but only two tracks will be built at first. The cost of the bridge will be about \$4,000,000. (March 7, p. 447.)

**PORTLAND, ME.**—The erection of a bridge to cost \$1,000,000 between Portland and South Portland is now practically assured, owing to the decision of the Portland Terminal Company (Boston & Maine and Maine Central) to pay \$400,000 toward the work. The county of Cumberland will pay \$500,000 as its share of the cost, and the Portland Electric Railway Company will pay \$100,000. The proportionate payment of all interested parties has been a subject of legislative discussion for several years, and it was finally settled by the last legislature.

**QUEBEC, QUE.**—An agreement between the city of Quebec and the Transcontinental Railway Commission regarding the location of shops at St. Malo and a passenger station at Palais, has been ratified. The estimated cost of the shops is \$1,500,000, and the union station, with yards, etc., \$1,700,000. The work is to be started at once and will be carried out by the Transcontinental Railway Commission, Ottawa, Ont.

**SEASIDE, MASS.**—The New York, New Haven & Hartford has let the contract for a new passenger station at Seaside on the Plymouth branch. The building will be 54 ft. by 26 ft. It will have a hard wood interior with cement floors, while the exterior will be stucco, with roof of red Spanish tile. The platform covers will be supported on ornamental stone columns. The granolithic platforms will be 400 ft. long and 8 ft. wide. The station will have waiting room, toilet room, women's retiring room, baggage room and ticket office. The grounds surrounding it will be laid out with flower beds and a circular drive. The structure is to be completed by November 1. New stations are nearly finished at Buzzard's Bay and East Bridgewater, Mass., on the same road.

**STRATFORD, ONT.**—The Grand Trunk will build a new station at Stratford at a cost of \$60,000, and will also put up large express sheds. The station is to be a two-story structure of red brick, trimmed with granite with slate roofing and tile flooring. The lower floor will be used for station purposes, while the upper will be occupied by the divisional staff.

**WEST OREGON CITY, OREGON.**—It is reported that the Portland, Eugene & Eastern will begin work within 90 days on the construction of a machine shop and foundry.

**ARICA-LA PAZ RAILWAY.**—Reference has been made in these columns to the excessively high rates prevalent on the Arica-La Paz Railway, and it was pointed out that if this newly completed enterprise hoped to compete successfully with the Antofagasta-Bolivia Railway it would be necessary to make a considerable cut in the rates scheduled. It is now announced that the management has reduced the established rate tariff by no less than 50 per cent. on ores from the Corocoro mining zone, consigned to the port of Arica, and 50 per cent. upon all coal carried. The company is also considering the advisability of reducing the through rate upon petroleum. These heavy reductions have not been arrived at without considerable pressure being brought to bear by the government of Bolivia, which, having originated and financed the line, naturally carries great weight with the management.

**RAILWAY CONSTRUCTION IN ARGENTINA.**—A goodly proportion of the new construction work which has been planned and already commenced in Argentina is upon the Central Argentine system, the Buenos Ayres Great Southern system, the Argentine North Eastern and others. In regard to the first named a double track is being built between Villa Ballester and Rosario de Santa Fé, a distance of 175 miles. On the Buenos Ayres Great Southern a number of branches are being built, in connection with which outlay a fresh capital issue is to be made. The Argentine North Eastern is constructing a branch from Concordia to Concepción in the neighboring republic of Uruguay. Argentina is also being connected with Chili by a new route by way of the Lerma Valley, joining up with the Huatiquina Railway.

## Railway Financial News.

**ATCHISON, TOPEKA & SANTA FE.**—See St. Louis, Rocky Mountain & Pacific.

**ATLANTA, BIRMINGHAM & ATLANTIC.**—According to press reports this company has been declared foreclosed, after having been given a month in which to settle all outstanding obligations. The date of sale has not yet been determined upon.

**BOSTON & MAINE.**—The directors have decided to pass the semi-annual dividend of 3 per cent. on the \$3,149,800 preferred stock due September 1.

**BUFFALO & SUSQUEHANNA.**—Judge Ormerod has entered a decree of foreclosure directing the sale of this company. W. F. Dubois, of Coudersport, Pa., was appointed special master to make the sale of the railroad in Pennsylvania.

**MANISTEE & GRAND RAPIDS.**—This line, which runs from Manistee, Mich., to Marion, 77 miles, and from Dighton to Hartwick, 5 miles, will be offered at auction on September 10. The upset price will be \$250,000.

**NATIONAL RAILWAYS OF MEXICO.**—The directors have decided to pass the semi-annual dividend of two per cent. on the \$28,831,000 first preferred stock, due August 10.

**NEW YORK, NEW HAVEN & HARTFORD.**—The stockholders will vote on August 22 on the question of authorizing an issue of \$67,552,400 debenture bonds. This issue has already been subscribed for twice over.

**PARAGOULD SOUTHEASTERN.**—See St. Louis Southwestern.

**PHILADELPHIA, BALTIMORE & WASHINGTON.**—The Public Service Commission of Maryland has sanctioned the proposed purchase of the Sparrows Point Railroad by this company from the Pennsylvania Steel Company for \$1,400,000. The Sparrows Point is a five-mile line built to connect the works of the Maryland Steel Company with the Union Railroad (thus connecting it with the Philadelphia, Baltimore & Washington) and also with the Northern Central, which operates it for 20 per cent. of the receipts.

**PITTSBURGH, CINCINNATI, CHICAGO & ST. LOUIS.**—The Ohio Public Service Commission has authorized this company to issue \$7,000,000 4½ per cent. bonds. It was impossible for the company to float at 92 an issue of that amount bearing 4 per cent. interest, as authorized by the commission on February 24, 1913.

**ST. LOUIS, IRON MOUNTAIN & SOUTHERN.**—The Missouri Public Service Commission has authorized this company to issue \$28,584,500 six per cent. first and refunding mortgage 40-year bonds.

**ST. LOUIS, ROCKY MOUNTAIN & PACIFIC.**—The property of this company will be sold to the Atchison, Topeka & Santa Fe, with the exception of what pertains only to the fuel business of this company.

**ST. LOUIS SOUTHWESTERN.**—Stockholders will vote on October 7 on the question of leasing the Paragould Southeastern, and also guaranteeing the payment of the principal and interest of 30-year five per cent. bonds of that road under a mortgage limited to \$5,000,000. The Paragould Southeastern runs from Paragould, Ark., to Blythesville, 37 miles, its stock being owned by the St. Louis Southwestern.

**SPARROWS POINT.**—See Philadelphia, Baltimore & Washington.

**UNION PACIFIC.**—The subscription price to stockholders for certificates of interest in Southern Pacific stock, will be \$92 per share, which includes the dividend accumulated on the stock since January 1, 1913. This makes the net price per share about \$88.

**WHEELING & LAKE ERIE.**—Kuhn, Loeb & Company, and Blair & Company, both of New York, have bought at public auction, the \$800,000 three year, 5 per cent. notes of the Wheeling & Lake Erie, which matured on August 1, together with all claims for interest from February 1, 1908, and the \$500,000 Wabash first refunding and extension mortgage 4 per cent. bonds, deposited as collateral for the notes. The price paid was \$9,863,550.

# Railway Age Gazette

PUBLISHED EVERY FRIDAY AND DAILY EIGHT TIMES IN JUNE, BY THE  
SIMMONS-BOARDMAN PUBLISHING COMPANY,  
WOOLWORTH BUILDING, NEW YORK.

CHICAGO: Transportation Bldg. CLEVELAND: Citizens' Bldg.  
LONDON: Queen Anne's Chambers, Westminster.

E. A. SIMMONS, *President.*

L. B. SHERMAN, *Vice-President.* HENRY LEE, *Sec'y & Treas.*  
The address of the company is the address of the officers.

### EDITORS.

SAMUEL O. DUNN, *Editor.*

ROY V. WRIGHT, <i>Managing Editor.</i>	H. H. SIMMONS	E. S. FAUST
W. E. HOOPER	H. F. LANE	F. W. KRAEGER
B. B. ADAMS	E. A. AVERILL	A. D. CLOUD
E. T. HOWSON	R. E. THAYER	GEORGE L. FOWLER
	A. C. LOUDON	

Subscriptions, including 52 regular weekly issues and special daily editions published from time to time in New York, or in places other than New York, payable in advance and postage free:

United States and Mexico.....	\$5.00
Canada .....	6.00
Foreign Countries (excepting daily editions).....	8.00
Single Copies .....	15 cents each

Engineering and Maintenance of Way Edition and four Maintenance of Way Convention Daily issues, North America, \$1.00; foreign, \$2.00.

Entered at the Post Office at New York, N. Y., as mail matter of the second class.

WE GUARANTEE, that of this issue 8,200 copies were printed; that of these 8,200 copies, 6,720 were mailed to regular paid subscribers and 850 were provided for counter and news companies' sales; that the total copies printed this year to date were 294,108—an average of 8,651 copies a week.

VOLUME 55. AUGUST 22, 1913. NUMBER 8.

## CONTENTS

<b>EDITORIAL:</b>	
Editorial Notes .....	315
Brotherhood Interference with Railway Discipline.....	316
The Decision in the Manufacturers' Railway Case.....	317
Buffalo, Rochester & Pittsburgh.....	318, 355
New Books .....	319
<b>LETTERS TO THE EDITOR:</b>	
*One Plan for Solving the Chicago Terminal Problem; by Gustave E. Lemmerich .....	320
<b>MISCELLANEOUS:</b>	
*New "Soo" Freight Terminal at Chicago; by Arthur R. Lord.....	321
Telephones in Ticket Offices.....	325
Western Railways Demand Adequate Compensation for Parcel Post Service .....	326
*The Darjeeling Himalayan Railway; by Lewis R. Freeman.....	327
Train Accidents in July .....	329
Traveling Engineers' Association.....	331
Foreign Railway Notes.....	326, 329, 330, 338
<b>GENERAL NEWS SECTION.....</b>	<b>342</b>

\*Illustrated.

SEVERAL instances of recent railway legislation indicate that the departments of the railways most directly affected by the legislation are not always consulted as freely as would seem advisable in presenting to the legislators the railway's side of the case while such legislation is pending. The interests of the railways as affected by state laws are naturally left to the legal department, and the other departments have scant means of knowing what legislation is pending except when they are advised by representatives of that department. When such matters are dealt with in a strictly legal manner some of the practical considerations which would be most seriously affected by the proposed law may occasionally be lost sight of. As an illustration, a law regulating clearances was recently enacted in a western state which imposes some unnecessary hardships on the railways within that state. After the enactment of the bill it

was explained in defense of the action by those who had been active in drawing it, that no objection to the requirements contained had been made by the legal representatives of the railways. It was found, however, that the first knowledge of the proposed legislation that was received by the engineering department of one of the largest railways affected came after the bill had passed, which was too late for objection to be heard. It is recognized that this is not the general rule, and much credit should be given the Special Committee on the Relations of Railway Operation to Legislation for the activities that it has undertaken in keeping its supporters advised of pending legislation and in getting practical railway men from interested departments to present their side of the question to legislators. The above example shows, however, that there is still room for more active co-operation, particularly with the engineering department.

WHILE the maximum ton-miles per hour per dollar of expenditure is the prime concern of all operating and mechanical officers, there is one officer, linking the two departments, with whom the accomplishment of this result is a most direct and exclusive duty. The traveling engineer's efforts are devoted to seeing that tonnage trains are moved with the greatest possible despatch and with the least cost for operation and supplies. After a train is once started on the road, the success of its trip depends very largely on the knowledge and ability of the engine crew and on the condition of the equipment given them to operate. The traveling engineer is to a large extent responsible for both. It is generally recognized by successful managers that effective supervision is the greatest aid to the highest efficiency in any line of endeavor. This is probably more true in connection with handling trains at the present time than ever before. Greater efficiency in operating trains is also more necessary now than ever before. Not only have the wages of the engine crew materially increased, but the locomotives are larger, important new devices are continually appearing and length and weight of trains are increasing. These all demand greater efforts from the traveling engineer than ever before. If results are to be obtained from the increased labor cost, more expensive equipment and larger trains, even more effective supervision of the engine crew must be given than is at present usually the case. The mystery of why locomotive appliances are more efficient on some roads than on others can often be explained by a knowledge of the number of engine crews or the number of engine miles a month for each traveling engineer on the division or system. It is impossible for a single man to effectively supervise a larger number of crews than he can ride with frequently. While this statement may seem to be almost axiomatic there are by no means a few managements that expect a single traveling engineer to train and direct 50 or more road crews. This makes it impossible for him to see any particular crew more than once a month as an average. With between 20 and 30 road crews a traveling engineer can produce results which will quickly make clear the importance of his position. An increase in the number of ton-miles per dollar expended will be assured if the traveling engineer is given a fair chance.

THE desire of traveling engineers to do their part in preparation for greater accomplishments could not be better illustrated than by the attendance, interest and activity of the members attending the Traveling Engineers' convention held in Chicago last week. At almost no time were there less than 200 members in attendance at the meetings and frequently there were over 300 present. Although there were but five reports presented for discussion and there were two sessions held on each of the four days, except the last, in practically every case it was necessary to cut off the discussion by a motion. The members seemed to be imbued with the idea of giving all the information they could from their own experience and of absorbing the maximum amount from the experience of others. The discussions were refresh-

ingly frank and no hesitation appeared in freely criticising methods or devices. The conventions of this association are unique in the fact that the members have no hesitation in saying exactly what they think. If their experience has been unsatisfactory, they are not at all backward in relating it and asking for an explanation of their failure. As might be expected with this spirit prevailing, much practical information appeared. All of this is evidence that the traveling engineer proposes to prepare himself to give the best results. It now remains, in many instances, for the managements to show an inclination to take full advantage of the opportunity.

#### BROTHERHOOD INTERFERENCE WITH RAILWAY DISCIPLINE.

THE charge has often been made by railway officers that the railway labor brotherhoods interfere with proper and needful disciplining of employees. The allegation sometimes has been denied by the spokesmen of the brotherhoods. W. G. Lee, president of the Brotherhood of Railroad Trainmen, recently has sent out a circular letter to the operating officers of the railways of the United States and Canada, which because of its direct bearing on the question of railway discipline, ought to be brought to the attention of the general public of these two countries.

Before giving the contents of Mr. Lee's circular letter, let us state some facts regarding the relations between the public, the railway managements and the employees which would seem to be incontrovertible. The railway is engaged in rendering a service to the public. The public holds the officers of the railways responsible for the way in which the roads are operated. The officers cannot operate the railways so as to satisfy and promote the welfare of the public unless they can procure the obedience of employees. In order to protect the legitimate interests of the employees they have organized unions; and in furtherance of their purpose the unions have secured the making of contracts or agreements between the employees belonging to them and the railways which are technically called "schedules." Differences of opinion sometimes arise as to the exact meaning of the schedules. These lead to conferences between the officers of the roads and the representatives of the employees at which interpretations of the schedules are adopted. If a difference of opinion arises between an officer—for example a trainmaster or a train despatcher—on the one hand, and a trainman, on the other, as to what the interpretation of a schedule means, as the trainmaster or despatcher is the superior of the trainman it would seem to be the latter's duty to obey orders, and then, if he sees fit, to report the matter to the grievance committee of his brotherhood, which, in its turn, if it sees fit, can take it up with the officers of the railway. To lay it down as a principle that an employee, when he differs from his superior officer regarding the meaning of the interpretation of a schedule, may and should refuse to obey his superior's orders is to lay down a principle of anarchy.

Attention is now invited to Mr. Lee's letter and the resolutions adopted by the Brotherhood of Railroad Trainmen, copies of which he has sent out to the railway officers:

CLEVELAND, Ohio, August 1, 1913.

General Manager, or other Operating Officers, Railways of the United States and Canada.

Dear Sir: In accordance with action taken by the Eleventh Biennial Convention of the Brotherhood of Railroad Trainmen, held at San Francisco, Cal., May 19 to June 4, I refer for your consideration copies of two resolutions adopted at the fourteenth and fifteenth days' sessions, pertaining to alleged schedule violation. Very respectfully yours,

W. G. LEE, President.

(14th day's proceedings, page 147.)

WHEREAS, The Brotherhood of Railroad Trainmen has, at great expense and effort, through its General Grievance Committees, negotiated schedules governing rates of pay and working conditions for men employed in train and yard service on various lines of railroad in the United States and Canada; and

WHEREAS, There appears to be a determined desire on the part of certain

officials to misinterpret or violate articles in schedules thus made; therefore, be it

*Resolved*, That the Eleventh Biennial Convention go on record as instructing its officers and the General Committees of the Brotherhood to strenuously oppose, in every consistent way, the action of such railroad officials as violate schedules; and, be it

*Resolved*, That our organization go on record as instructing its members to carry out contractual and authorized instructions of railway officials, while at the same time maintaining the position that the General Grievance Committees of the Brotherhood will not be disposed to accept without question the statement of a railroad official than one or more of our members have been insubordinate, when, as a matter of act, the alleged insubordination has been nothing more than an insistence that schedule language should be literally adhered to; and, be it further

*Resolved*, That a copy of this resolution be sent over the President's signature to General Managers of all railroads in the United States and Canada.

(15th day's proceedings, page 164.)

*Resolved*, That when interpretations of schedules are agreed to between railway officials and the authorized General Grievance Committees of the Brotherhood and said agreements as interpreted are ordered violated by railroad officials, that such instructions shall be considered unlawful and a refusal on the part of our members to carry out such instructions shall not be considered insubordination. Further, that General Grievance Committees of the Brotherhood are instructed to protect members disciplined on account of their failure to carry out such illegal instructions.

The italics, which include the most important part of the matter quoted, are ours. If employees seek to live up to the letter and spirit of the resolutions, what must be the results? The intent of these resolutions is to divorce responsibility and authority—a thing that has never yet failed to produce evil results.

The stand taken by the Brotherhood of Railroad Trainmen in these resolutions is so obviously contrary to fairness and reason, and so clearly designed and adapted to interfere with the maintenance of the discipline which is necessary to efficient and safe operation of railways, that it must receive unqualified condemnation from every fair-minded person. It is on a par with the communication sent on September 2, 1911, by Warren S. Stone, Grand Chief of the Brotherhood of Locomotive Engineers, to the members of the latter organization on the Harriman Lines, the Illinois Central, and some other roads on which there was a strike of shop employees. There were a number of men on these lines holding official positions who retained their memberships in the Brotherhood of Locomotive Engineers; and Mr. Stone said in his letter that "members holding official positions cannot do the work or take the place of strikers without violating the laws of the organization." In other words, he sought to give orders to officers of the roads which they could not obey without disobeying the orders of higher officers of the roads. These incidents illustrate the ever-increasing arrogance of some of the unions and their leaders. If the officials of railways cannot secure the implicit obedience of employees to their orders how can they be held responsible by the public for the results of their railway operation?

It is to be hoped that the managers of the railways will meet squarely the issue raised by the Brotherhood of Railroad Trainmen; and that every employee who, in accordance with these resolutions, refuses to obey the orders of any of his officers, will be summarily and finally discharged from the service. The right of officers to have their orders obeyed should be maintained even though in order to do so it is necessary to go through a bad strike. The lack of proper discipline is the greatest curse of railway operation in America. It is the main cause of railway accidents; it is the main cause of the preventable wastes in railway operation; and when the brotherhoods, instead of co-operating to improve the conditions, assume openly an attitude that is adapted to aggravate them, they lose their claims to public confidence and respect. Perhaps it is not without significance that it is the organization which has been promoting full crew legislation in the pretended interest of safe operation that now adopt resolutions which are adapted to further impair the discipline that is most essential to safe operation.

### THE DECISION IN THE MANUFACTURERS RAILWAY CASE.

THE most important work that the Interstate Commerce Commission has done has been to reduce unfair discrimination by railways between shippers. In the long series of opinions by the commission regarding unfair discrimination, few have been as important as that recently rendered in the case of the Manufacturers Railway Company et al versus St. Louis, Iron Mountain & Southern Railway et al. The Manufacturers Railway is owned by the same interests that control the Anheuser-Busch Brewing Association of St. Louis. It was originally constructed to replace the horses and wagons which had previously been used for hauling this concern's raw materials and products between the railways and its plant. Later, the railway, which at its inception, was merely a plant facility, was taken over by a separate corporation controlled, however, as already indicated, by the same interests that control the brewing company. The Manufacturers Railway demanded from the trunk lines allowances from their rates for switching cars between their lines and the industries located on its tracks. These industries include some not controlled by the Anheuser-Busch Brewing Association, but the evidence showed that about 76 per cent. of the total traffic of the railway is handled for the brewery, and that approximately 85 per cent. of the total business within the immediate zone of the brewery's buildings is handled for it. Prior to March, 1910, the trunk lines made allowances to the Manufacturers Railway of from \$3.50 to \$5.50 per car. On the date mentioned these were canceled. The Manufacturers Railway then appealed to the commission for an order requiring the trunk lines to pay it \$4.50 per car. It based its appeal on the ground that it rendered a service to the trunk lines in delivering them traffic originating on its rails which was worth this amount, and that as the trunk lines made similar allowances to other terminal railways it was an unfair discrimination for them to refuse to make the allowance to the Manufacturers Railway.

The commission found that the railways had in the past made allowances to the Manufacturers Railway because the interests that owned both it and the brewery had used the large traffic of the latter as a club with which to coerce the trunk lines. It decided that the Manufacturers Railway is a common carrier and that the payments formerly made out of their through rates by the trunk line were "absorptions in compensation for services rendered to the trunk lines and were in no sense divisions of joint rates as for services rendered for the shippers served by the railway." "In the absence of an undue discrimination with respect to these absorptions the commission could make no lawful order with reference thereto," and "the defendant trunk lines in delivering freight at the St. Louis rate to points on the rails of the Terminal Railroad Association of St. Louis and in refusing to bear the expense of similar delivery by the (Manufacturers) Railway upon the rails of that carrier are not subjecting the shippers located on and served by the (Manufacturers) Railway to undue prejudice and disadvantage." In holding thus, the commission evidently had in mind the fact that the Terminal Railroad Association is controlled by the trunk lines themselves, and that therefore delivery on it is in effect delivery on the rails of the trunk lines themselves, while the Manufacturers Railway is owned by separate interests, and therefore delivery on its rails is delivery to a point beyond the rails of the trunk lines. Furthermore, the trunk lines had canceled their allowances to other industrial railways in St. Louis as well as to the Manufacturers Railway. In the circumstances, the commission found that the only lawful order it could make would be one for the establishment of joint rates if the conditions warranted such action. Under joint rates "that part of the service performed by the (Manufacturers) Railway would be in the contemplation of the act a service performed for the shipper to be paid for by the shipper." The commission, therefore, held that the trunk lines might continue to collect their regular through rate to St. Louis and that the switching rate charged by the Manufacturers Railway might be \$2 a car, which, however, must be in addition

to the St. Louis rate and be paid by the shipper to whom the service is rendered.

The majority opinion was written by Commissioner Clements. Commissioner Harlan wrote a concurring opinion in which he contended that the Manufacturers Railway is not a common carrier, but merely a plant facility. To many persons it will seem that the evidence sustains in the view taken by Mr. Harlan rather more than that taken by Mr. Clements. The railway was originally constructed as a plant facility. Most of its tracks are so laid in relation to the brewery that it is a practical impossibility for them to be used in the rendering of any service to the public. But the very definition of a "common carrier" is one who holds himself out to carry for the public and has the facilities with which to do so. There are parts of the lines of the Manufacturers Railway which are so situated that it can and does serve industries other than the brewery. Doubtless it was this fact that determined the commission's decision as to the Manufacturers Railway's status as a carrier. Obviously, the fact is that as to some of its lines the Manufacturers Railway is a common carrier, and that as to others, it is not. Why could not the decisions of the commission and the courts in regard to an instrumentality of this sort be made to conform to the facts? If they could be and were the difficulties of dealing with the questions involved would be much reduced.

As things are, the decision leaves some problems unsolved. The clear intent of the commission is that the Manufacturers Railway and those who control it shall not be allowed to participate in the rate of the trunk lines. Commissioner Clements adds: "We should also regard in the same light any effort on the part of the trunk lines to accomplish these results by shrinkage of their St. Louis rates or by means of per diem or demurrage agreements or practices." Per diem is a payment by a railway for the use of foreign cars. All cars are foreign to the Manufacturers Railway, because it owns no cars of its own. If it were not required to pay per diem, it would get for nothing the use of cars which did not belong to it. Obviously, this would be contrary to the intent of the commission's decision. It follows that some arrangement must be made under which the Manufacturers Railway must pay per diem. Demurrage is what is paid by the shipper for the detention of a car after he has had a reasonable amount of free time in which to unload it. Since other shippers are required to pay demurrage, obviously there would be an unfair discrimination in favor of shippers situated on the Manufacturers Railway if they were not required to pay demurrage. The question arises, however, as to whom they should pay it? Apparently, to the Manufacturers Railway. If the Manufacturers Railway pays per diem to the railway that owns a car for the use of it while on the farmer's tracks it would seem to follow that it has a right to collect demurrage from the shipper who unduly detains the car. It would appear, however, that the per diem and demurrage arrangements must be closely supervised in order to prevent the Manufacturers Railway from making any profit from them. The commission has held that the switching service that it renders is worth \$2 a car, and if by any means the Manufacturers Railway receives more than this, it must, under the commission's decision, be held that those who own it are getting a rebate.

If this decision involved only the status of the Manufacturers Railway it would be of little importance. It is of very great importance because it is a precedent for determining the status of numerous industrial railways occupying a position analogous to that of the Manufacturers Railway. All over the country large manufacturing concerns have organized as separate corporations railways which are virtually plant facilities, and have then used the power that they derive from the large traffic that they control to coerce the trunk lines into paying to them switching allowances and divisions of through rates which are virtually rebates. This has been one of the most pernicious forms of unfair discrimination that have been in vogue since the practical abolition of secret rebating. It has not been abolished largely because competition between the various railways has



rendered it extremely difficult for them to make agreements to take concerted action regarding it. In its efforts to break up this form of discrimination the commission is rendering a great service to the railways, the small shippers and the public. In justice to the railways, however, it ought to be understood that they are cooperating with the commission in accomplishing the reform. They voluntarily withdrew the allowances that they had been paying to the Manufacturers Railway when the commission rendered a decision in another industrial railway case indicating that such allowances were illegal. Furthermore, the testimony of railway officers regarding the allowances to the Manufacturers Railway afforded the basis for the decision of the commission in its case. The only persons who are not anxious to see the abolition of such illegal and vicious relations as formerly existed between the trunk lines and the Manufacturers Railway, St. Louis, are the big shippers who have been profiting by such arrangements.

#### BUFFALO, ROCHESTER & PITTSBURGH.

IT is probable that if the management of the Buffalo, Rochester & Pittsburgh were asked to account for the remarkably good showing which that company made in the year ended June 30, 1913, even when compared with the good showing made in the previous year, they would credit operating efficiency, high standard of maintenance and conservative financing. But this is a description of the results that have been obtained rather than an explanation of how these results were brought about. Operating 576 miles of road in a highly competitive territory, the Buffalo, Rochester & Pittsburgh earned \$10,947,246 from operation in 1913, an increase over 1912 of 13 per cent., and had net corporate income, after the payment of expenses, taxes, interest, etc., of \$2,126,994,\* an increase of over 20 per cent. compared with the previous year. The increase in operating revenue was the result in part of a better business year in the territory served, and also apparently in part to a somewhat increased share of the business going to the B. R. & P. The increase in net was the result of economies due, as will be explained more fully later, in part to an important increase in ore traffic southbound and in part to a more efficient utilization of labor; and finally, to economies resulting from improved facilities paid for without any proportionate increase in fixed charges.

That the company was able to more than hold its own in getting a share of a general increase in business is in itself pretty strong evidence that there was an improvement in service somewhat more than commensurate with the general progress of the art of railroading. The greater volume of ore traffic southbound may also be directly attributed to the same high standard of service.

With an increase in the ton miles carried of 19.72 per cent.—the total revenue ton mileage in 1913 was 2,040,358,520—transportation expenses amounted to \$3,580,617, or 12 per cent. more than in 1912, and consumed but 32.71 per cent. of total operating revenue, as compared with 32.88 per cent. in 1912. This holding down of transportation expense was in the face also of an increase of 6.79 per cent. in the passengers carried one mile—passenger mileage in 1913 totaled 54,573,203.

In commenting on the operation of the Buffalo, Rochester & Pittsburgh, the president of one of the large railroad systems recently remarked that the B. R. & P. people had nothing to do but run their railroad, and they ran it remarkably well.

*Adequate supervision is one of the real explanations of the B. R. & P. success.* This might not be sufficient without many of the natural advantages which the B. R. & P. has; without its record of conservative financing, improvement out of earnings, and without its farsighted and aggressive traffic policy, to account for the results that were obtained last year, but it is the most important factor in the explanation

\*This net includes, of course, "other income," which was increased last year by \$224,164 more received for hire of equipment than in the previous year.

of the effectiveness of the machine to render service to the public and to earn an adequate return on its cost to its owners.

The Buffalo, Rochester & Pittsburgh is a short line, although a very busy one, but its importance among American railroads and in the development of railroad science is much greater than would be indicated either by its mileage or by its business and earnings, adequate as they are. On this road are being demonstrated some of the principles of what might be called intensive railroading. This phrase, however, very inadequately describes all of the methods of work which are being used to obtain such highly satisfactory results as those shown in 1913. Along with the successful effort to increase the effectiveness of the plant goes a recognition of the reciprocal relations which exist between employer and

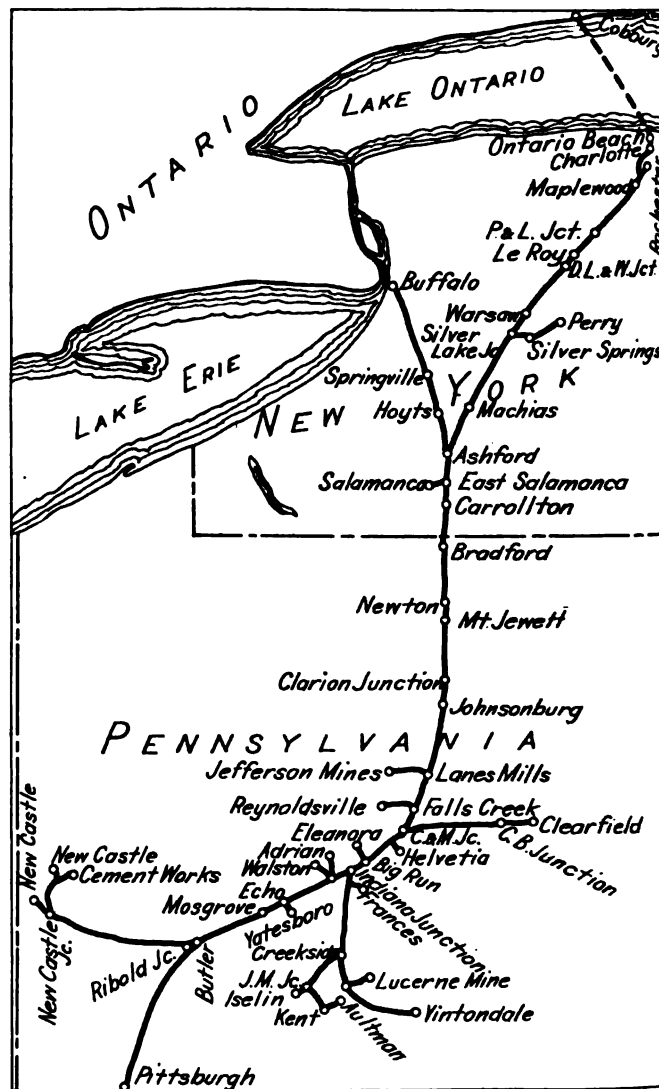

The Buffalo, Rochester & Pittsburgh.

employed, and between a public service corporation and its patrons; and, in fact, it is directly through the recognition of these relations that the results are being obtained.

Without doubt, the full-crew bill in New York, the successfully enforced demands of organized labor for higher wages, and the sometimes purposeless legislation relating to railroads have their bad effects on the B. R. & P.; but the management has accepted what it cannot remedy, and more important, has remedied those things which lay within its power. A forced increase in the wages of organized labor has not been partially offset by a refusal to recognize the higher cost of living of clerks and unorganized labor, or by a blind refusal to permit any increases in salaries of railroad officers, nor has vicious legislation been met with reprisals on com-

munities unable to defend themselves. In 1913 the salaries and expenses of clerks and attendants in the general offices were increased over 9 per cent. The expenses for superintendence in 1913, including superintendence under each one of the four classes of operating expenses and salaries of general officers, increased 15 per cent.

The Buffalo, Rochester & Pittsburgh spends 5.1 per cent. of its total operating revenues for superintendence under these five heads, and 3.67 per cent. of its total operating revenues. The Pittsburgh & Lake Erie, which is a model of operating effectiveness and has unusually adequate supervision, spends 5.06 per cent. of its total operating expenses for superintendence and 2.5 per cent. of its total operating revenues; the very considerably smaller proportion of operating revenue being due, of course, to the greater traffic density on the P. & L. E. The Norfolk & Western, which is one of the best managed coal roads in the East, spends 3.6 per cent. of total operating expenses for superintendence, which is 2.3 per cent. of total operating revenues. The comparison here is simply for the purpose of measuring the adequacy of the B. R. & P.'s expenditures for supervision and not as any contrast or parallel of policy as between the other roads mentioned. What can, however, be said with justification is that this policy of liberal expenditures for supervision is highly successful on the B. R. & P.

To give some concrete examples of this success: Ton mileage increased 19.72 per cent. and revenue freight train mileage 8.95 per cent.; passenger mileage increased 6.79 per cent. and passenger train mileage 4.60 per cent.; the number of passengers per train mile increased from 38 to 39; the number of loaded cars in freight train from 19.52 to 20.52; the percentage of loaded cars in freight train from 57.35 to 59.76; the number of tons of freight per loaded car from 33.17 to 34.61, and the revenue train load from 647 to 710 tons. While on the face of it the increase in train load is the most remarkable showing made by these figures, in fact, the increase in car loading is a better and more noteworthy example of the gain in efficiency through supervision.

The tonnage of iron ore carried in 1912 amounted to 263,574 tons, and in 1913 to 781,201 tons. Coal and coke traffic on the B. R. & P. moves north from the branches in the vicinity of Punxsutawney to the lakes, and the securing of iron ore traffic from the lakes south to Punxsutawney in itself would account for a very large increase in the *average* revenue train load. It might conceivably also account in some part for the increase in car loading, but it is probable that the increase shown in 1913 over the remarkably good car loading in 1912 was due to a continuance and improvement upon the policy of constant supervision and attention to this detail.

Another factor in the increased average train load, which operated, however, only for part of the year, was the installation of heavier power. One passenger locomotive and nine freight locomotives were bought and paid for during last year, and in addition, 12 freight locomotives and three passenger locomotives were ordered, but were not received in time to be taken into last year's account. The freight locomotives that are being bought are of the heavy Mikado type, and the new passenger locomotives are heavy Pacific type engines.

The Buffalo, Rochester & Pittsburgh in 1913 carried 12,490,608 tons of freight, of which 7,980,204 tons were bituminous coal, 1,472,481 tons manufactures and 781,201 tons iron ore.

The percentage of total operating revenues going to each class of operating expenses in 1913 and 1912 was as follows:

	1913.	1912.
Maintenance of way and structures.....	14.23	12.52
Maintenance of equipment.....	19.74	18.94
Traffic .....	1.30	1.26
Transportation .....	32.71	32.88
General .....	2.05	2.14
Total .....	70.03	67.74

During 1913 the company spent net \$816,021 for improvements to property, exclusive of equipment. The most important of these improvements were \$138,822 for bridges and culverts, \$136,734 for automatic block signals, \$117,147 for sidings and yard extensions, and \$115,898 for second track. It is noteworthy that next to the largest single item for improvements was spent for a part of the plant which can add in no way to revenues and will be an added charge to maintenance. This is block signals, of course. In addition to the 53 miles of block signals installed last year, a total of 76 miles from Gainesville to East Salamanca and from Falls Creek, Pa., to Punxsutawney are now being installed. The expenditures on new rolling stock amounted to \$1,424,892. Although the total amount spent for additions and betterments, including new rolling stock, amounted to \$2,240,913, the net increase in the bonded debt of the company was but \$755,000. The discount on funded debt issued (there was a total of \$1,123,000 consolidated mortgage 4½ per cent. bonds sold, part of the proceeds of which, of course, were used to retire outstanding obligations) was \$4,936, all of which was charged to profit and loss, there being no unextinguished discount on securities sold carried on the balance sheet. The company is peculiarly fortunate in its relations with its bankers. In a way these relations are unusually close, control of the company being held by a single firm of bankers and their immediate friends; but the closeness of these relations with the bankers has facilitated rather than hindered the independent management of the property, and at the same time has enabled the company to get remarkably good net prices for its securities, even in a time of poor bond markets. Since June 30 the company sold a small issue of equipment notes, and it is understood that while the negotiations for the sale of these notes were carried on by the banking firm, and all the advantages of a wholesale banking house's connections were availed of, no charge whatsoever was made the railroad company for this service, the only bankers' commission being that of the retailers.

The following table shows the remarkably successful financial results that were obtained in 1913, even as compared with the very prosperous year 1912:

	1913.	1912.
Average mileage operated .....	576	570
Freight revenue .....	\$9,411,879	\$8,174,728
Passenger revenue .....	1,127,612	1,058,260
Total operating revenues .....	10,947,246	9,542,368
Maint. of way and structures.....	1,557,963	1,195,263
Maint. of equipment.....	2,161,210	1,807,077
Traffic expenses .....	141,659	120,108
Transportation expenses .....	3,580,617	3,137,300
General expenses .....	224,441	204,481
Total operating expenses .....	7,665,891	6,464,229
Taxes .....	216,000	204,000
Operating income .....	3,057,990	2,874,147
Other income .....	1,018,718	779,578
Gross corporate income.....	4,076,708	3,653,726
Interest and rentals .....	1,949,714	1,882,831
Appropriations .....	450,293	379,564
Dividends .....	980,000	885,000
Surplus .....	686,701	506,330

NEW BOOKS.

*Freight Rates; Studies in Rate Construction.* By John P. Curran. Published by the Railway Text Book Publishing Company, Monadnock Block, Chicago. 367 pages. Cloth. Price \$5.

The purpose of this book is to give the student of traffic matters a comprehensive understanding of the methods employed in rate-making by describing and explaining thoroughly the various rate bases and structures. After a brief introduction giving some of the general principles of rate-making, and a brief history of railway regulation, the book consists mainly of compilations of extracts from various tariffs which define the rate territories, groups, etc., with detailed explanations to show how the tariffs are built up.

# Letters to the Editor.

## ONE PLAN FOR SOLVING THE CHICAGO TERMINAL PROBLEM.

CHICAGO, August 14, 1913.

TO THE EDITOR OF THE RAILWAY AGE GAZETTE:

The main problem in the solution of the Chicago terminal situation is to get the railroads to co-operate. The railway map of Chicago is a systemless chaos, and considering the fact that the railroads will have to electrify their lines within the city limits sooner or later, and that electrification of these lines on the present location is absolutely impossible financially, they will have to co-operate eventually.

If the railroads would forget for a moment their own jealousies and would study the terminal situation in Chicago, they would find a solution that would be satisfactory to themselves both from a financial and from an operating standpoint. They own practically enough property to provide for a suitable grouping of the roads avoiding grade crossings

tions being connected at the south end so that trains coming from the east could connect with western lines at the station or vice versa. Each of the two proposed passenger stations has 30 platform tracks which are divided into incoming and outgoing groups. The station proper would be over about the center of the platforms, reducing the length of the passengers' walk about half. The suburban business could be carried on the eastern lines to the north side of the loop near Polk street, and on the western lines suburban business could be handled at practically the same point as at present, just east of Canal street. This suburban business along these lines would not have to enter the union station at all. Transfer stations could be provided for bringing passengers to and from the union station. A portion of the space in the station loops would be utilized for express and mail business. There would also be a few tracks for engine storage, coaches, etc.

The freight houses in this layout constitute a union freight station in the loop district, each railroad to keep its own individuality in the receiving and delivering of freight, but the handling to and from the cars to be managed as a unit. The houses are located across the tracks and between two

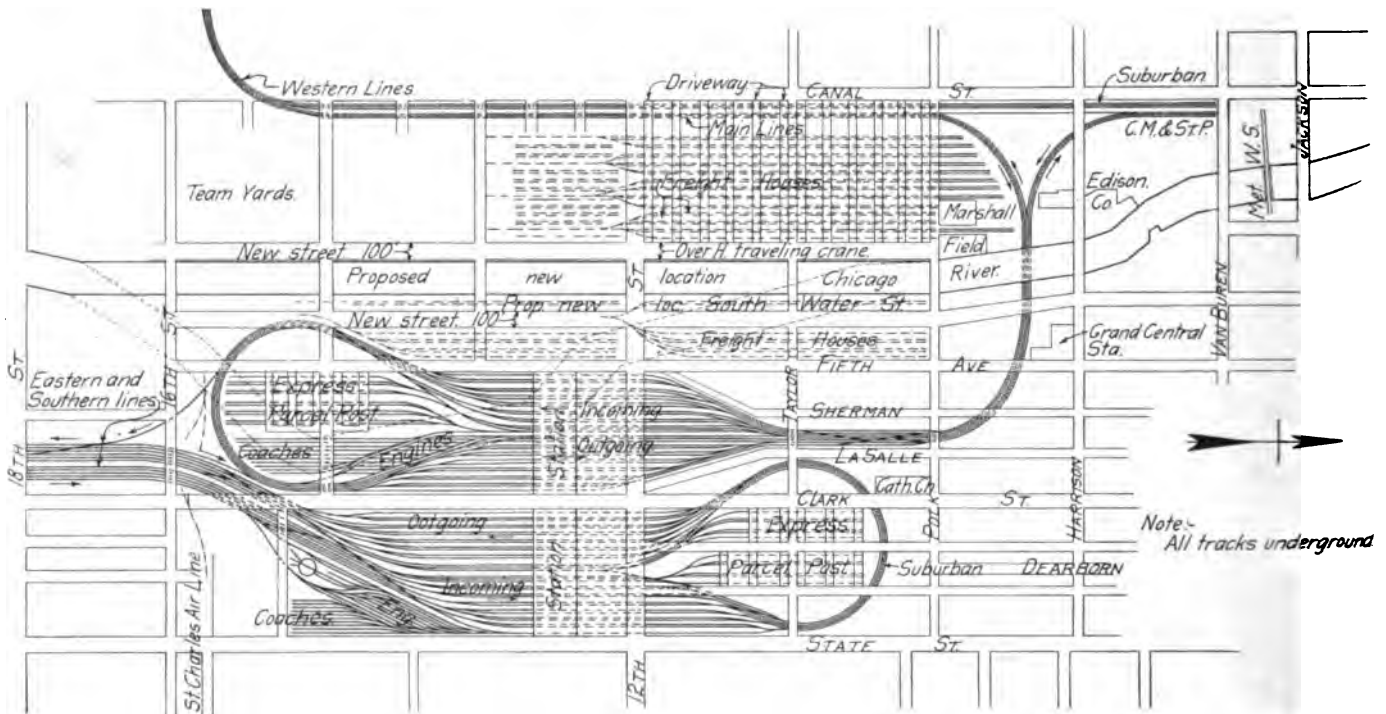

Layout for Proposed Union Station at Chicago.

and by some rearrangements they could create ideal layouts which would also result in material savings in the running time to and from the city. It should not be an unsurmountable difficulty for a fair minded commission to solve this question.

The accompanying sketch shows a study of a union station on these lines on the assumption that the river can be straightened. This union station is located south of Twelfth street between State street and Fifth avenue extended. All tracks in this layout are below the surface and would be in open cut wherever possible. At certain places the streets might have to be raised a few feet.

The proposed union station consists of two units, one for the eastern and southern lines and one for the western and northern lines with the possible exception of the Chicago & North Western and the Illinois Central. Should the latter be included, however, some of that company's tracks could be used for northbound passenger service with the Rock Island and Pennsylvania for southbound passenger service. All freight could be handled on the Western Indiana.

The stations are of the through type, the adjacent sta-

driveways, the freight to be lowered on electric trucks to the platforms. These houses should be connected above the driveways with bridges. The upper stories could be utilized for warehouse purposes, which would enable the renters to receive and deliver freight to any railroad or any other tenant. An electric truck could be delivered to such tenants for loading and unloading.

Another solution of this problem could be made by locating a union station for the western lines east of Canal street and the river and a union freight station east of the river, extending to Clark street, leaving the union station for the eastern lines at the same location shown on the sketch. A union station for the western lines at this point also permits a through station south of Twelfth street, leaving the suburban station at about its present location.

The main point is that the railroads should get this co-operation idea, and plans can then be developed which will prove successful from a financial and operating standpoint. The railroads have co-operated in other lines to great advantage and they could get the same results in this problem.

GUSTAVE E. LEMMERICH.

# NEW "SOO" FREIGHT TERMINAL AT CHICAGO.

Details of Design and Construction of Large Elevated Freight Terminal Carried on Reinforced Concrete Structure.

By ARTHUR R. LORD.

The Central Terminal Railway Company is building a modern elevated freight terminal at Chicago for the use of the Minneapolis, St. Paul & Sault Ste. Marie. The new terminal is located near the center of the business and manufacturing district of the city and covers 11 city blocks. The terminal faces at its northern end on the projected Twelfth street boulevard and the plans accord with the widening and beautifying of Twelfth street, for which the voters of Chicago have already authorized a bond issue. Extending south from Twelfth street the structure occupies the entire area between Canal and Clinton streets, crossing Twelfth place, Thirteenth street, Maxwell street, Liberty street, Fourteenth street, Barber street, Fourteenth place and Fifteenth street, and then turning to the west the tracks cross Clinton, Jefferson and Union streets, and connect at Halsted street with the present Baltimore & Ohio Chicago Terminal tracks, which are used by the Soo line in entering Chicago.

The city of Chicago would not permit the building of a terminal of this size at the street level, or with any grade crossings. The problem resolved itself, therefore, into two alternate possibilities; retaining walls could be built along the streets and the area filled, with bridges across the streets and large terminal storage houses provided in addition to the freight houses required for the actual handling of the freight to and from the cars. This project would have involved 2½ miles of retaining wall 29 ft. high, retaining over 600,000 cu. yds. of fill. To provide equal storage capacity to that shown on the present plans an additional warehouse having 520,000 sq. ft. of floor space would have been required. If this warehouse were built on the same site, over the tracks, it would of course be necessary to elevate and lower all the merchandise stored in these higher floors. And the building of the additional warehouse over the tracks would result in the loss of that flexibility in the track arrangement, which is a most valuable feature of the present design.

The second possibility is the one embodied in the present plans. The terminal tracks under this arrangement are all carried on a deck structure continuing uninterrupted across the streets, almost the entire area of the property beneath this structure, excepting the five streets left open for traffic being available for storage purposes, amounting in all to over 600,000 sq. ft. All of this space is at the street level directly accessible to teams for city distribution and served also by the tracks of the Chicago Tunnel Company. From the street the track deck is reached by two incline driveways, one from Twelfth street on the north and the other from Fourteenth place on the south. These lead directly to the team tracks, the traveling crane and the driveway between the freight houses.

The Chicago Tunnel Company is providing several connec-

tions with its system of freight carrying tunnels which serve all the principal buildings in Chicago. Universal freight station No. 4 of this company will be located at Twelfth and Canal streets under the in-freight tracks. Three elevators connect the tracks of the Tunnel company with the tracks of the Universal freight station and the freight houses of the Central Terminal Railway Company.

The freight houses and office building are located at the

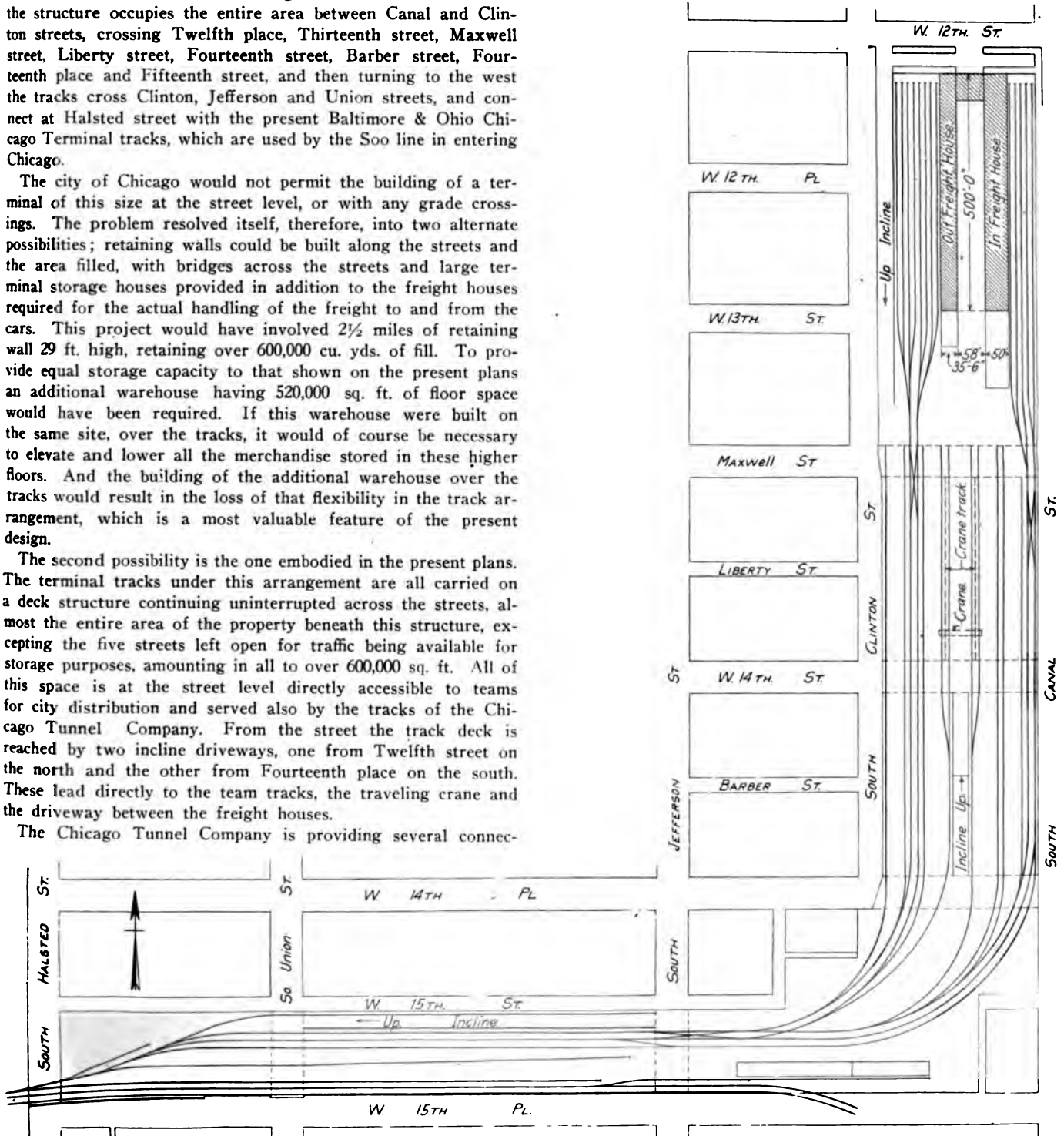

Track Layout of New "Soo" Freight Terminal at Chicago.

north end of the terminal adjacent to Twelfth street. The main in and out-freight houses are at present being built 500 ft. long, provision being made for a future increase in length. The in-freight house is being built four stories high but designed for two additional stories when the need for additional space arises. The in-freight house is served by five tracks along Canal street with a capacity of 80 cars. The building is 50 ft. wide with a floor space of about 100,000 sq. ft., which will be doubled when the extensions now contemplated are made. The plans call for a cold storage chamber on the first floor. Five elevators distribute the freight received on the second floor to the upper and lower floors. One tunnel elevator serves the

18 on the second. Fifteen scales flush with the floor serve these doors. The entire west side of the second story of the out-freight house is open to the tracks with columns 20 ft. on centers and full width doors between. Two freight elevators serve the first and second floors. A ten-ton 20 ft. radius pillar crane for handling heavy castings, etc., will be located on the out-freight platform, so as to serve cars, trucks and platform from one fixed position.

Between the in and out-freight houses is a 58 ft. driveway on both the ground and second floors. The ground floor driveway is entered directly from Twelfth, Maxwell and Canal streets. The second floor driveway is reached by the incline



Perspective Drawing of Complete Terminal Which Has Been Changed in Some Details During Construction.

second floor directly. Three spiral chute conveyors are also being installed. At present one scale is provided on the first floor and four on the second, set flush with the floor at shipping doors. The plans provide for 14 team shipping doors on the first floor and 19 on the second. The entire east side of the in-freight house is open, with columns 20 ft. on centers and with full width doors between permitting cars to be spotted with great ease. A screen wall of concrete and brick hides the freight tracks from Twelfth street boulevard.

The out-freight house is to be two stories high and is served by eight tracks with a capacity of 105 cars. The building is 35 ft. 6 in. wide, the present floor area being 65,000 sq. ft., with provisions for future increase. The freight is received from the driveways through 16 team doors on the first floor and

from Twelfth street and Fourteenth place. The floors of the in and out-freight houses are 3 ft. 6 in. above the top of the paving. The second floor of the in house is 4 ft. above top of in-freight rail, while that of the out house is 4 ft. 3 in. above top of out-freight rail.

Along Twelfth street at the north end of the freight houses the freight and business office of the M. St. P. & S. S. M. will be located in a four story (ultimately six story) building 143 ft. 6 in. x 36 ft. in plan. The ground floor driveway entrance is through this building.

The power and heating plant is located under the out-freight tracks near Twelfth street. The coal is received on the west out-freight track and dumped directly into the bin below, and the ashes are hoisted to cars on the same track. Ultimately



Perspective of Freight Buildings Facing Twelfth Street As They Are Being Built.

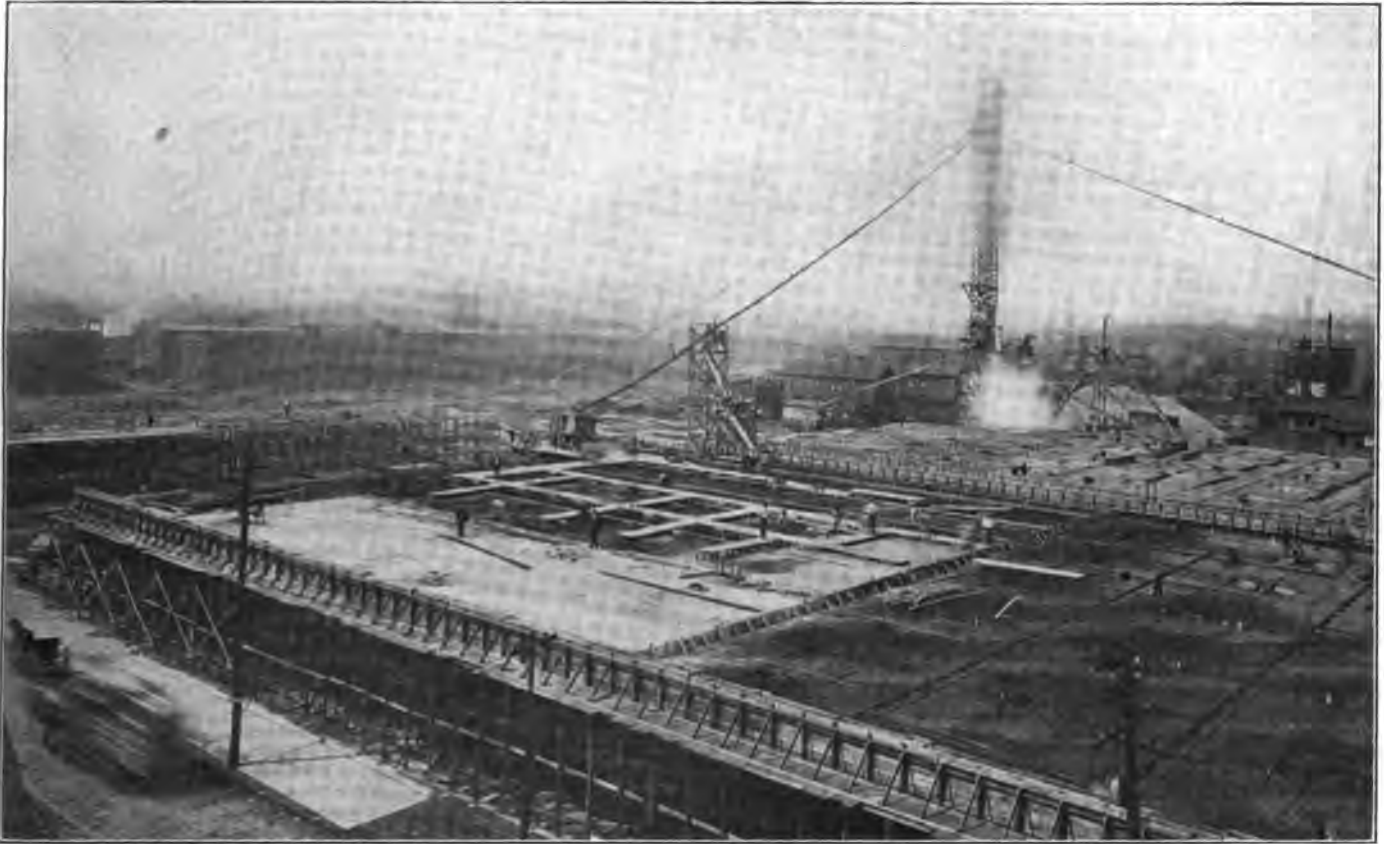

Early Work on the Track Slab Showing Many Stages of Construction.

all heat and power required for the operation of the terminal will be developed by this plant. Provision has been made for expansion in the future. A reinforced concrete chimney 140

ft. high is now being constructed by the Custodis Chimney Company.

The team tracks are located south of Maxwell street and



General View of Terminal on July 13. The Three Concrete Plants Are Shown, the One in the Foreground Having One Mixing and Two Distributing Towers.

have a total capacity of 259 cars, which can be greatly increased when the need arises. A traveling crane serves four tracks near the south incline driveway. A 9 ft. x 20 ft. automatic scale is located in a central position with regard to the inclines and driveways. The flat unobstructed deck permits the tracks to be rearranged at any time as experience may show to be desirable for the more efficient operation of the terminal.

The elevated structure is designed to carry any arrangement of tracks on 12 ft. centers with the heaviest loading which it is considered that the future may by any possibility impose upon them. The track deck is absolutely unbroken by beams and is to be ballasted, permitting of unlimited elasticity in the track arrangements. The structure is built of reinforced concrete throughout, with the exception of the columns at the track side of the in-freight house. Concrete was chosen because of lower first cost, lower maintenance cost and greater permanency as compared with structural steel. The use of steel would also have required either through girders at the street crossings, destroying the elasticity of the track arrangement, or an increase of several feet in elevation of the entire structure above the street. Structural steel construction of the same strength and properly fireproofed would have cost very much more than the concrete structure.

Almost all types of reinforced concrete construction are to be found in the structure, the requirements of each case being studied and the type best suited being used. For the track slab with the heavy load of ballast and trains, figures soon showed that the flat slab construction with depressed heads led all other types by a very wide margin from the standpoint of cost and desirability in every way. This construction gave an absolute minimum of thickness over the streets, which in turn determined the elevation of the entire structure. For this sort of structure the flat slab is in the opinion of the designers absolutely without a rival. In the freight houses proper with a loading of 350 lbs. per sq. ft. the flat slab also enjoyed considerable advantage in cost over its nearest competitor, as well as making possible a more attractive building. For the office building and the out-freight house roof, where the loads are light, tile-concrete joist construction was used as being cheaper

and somewhat superior in the matters of condensation and noise conduction. For the driveway slab between freight houses a reinforced concrete girder, beam and slab construction was found best adapted, as the panels were rectangular. The retaining walls are of a semi-gravity type, being lightly reinforced for temperature and bending stresses. On account of the vibratory nature of the load Havemeyer deformed bars, furnished by the Concrete Steel Company, New York, were used very



Bending Slab Reinforcement in Place.

largely. Some square twisted bars were used and a small number of plain rounds.

Construction work was started on the footings in August, 1912, and continued with a small force, which was increased as rapidly as the clearing of the site and acquisition of property would permit, with very few interruptions throughout the fall and winter. There are about 2,000 columns in the structure. The footings rest on hard blue clay at an elevation of 2 ft. above city datum. The top of the slab is 31.18 ft. above this datum at the crossing of Jefferson street, running down on a very slight grade to 26.23 ft. at the freight houses. In May the construction of the track slab was begun and at the present time



Surface of Track Slab Ready for Waterproofing.

about three city blocks have been completed. The bridge across Union street and the slab across Fourteenth place are constructed. Work on the freight houses was delayed, owing to difficulty and delay in acquiring certain property, but at present all but one of the interfering buildings have been razed. All the reinforcing steel in the track slab is being bent in position, which results in a large saving, and in better work. The Havemeyer  $\frac{3}{4}$  in. round bars used on the larger portion of the work bend very easily, but the  $\frac{3}{4}$  in. square twisted bars used in one section are very much more difficult to bend, although even here bending in position is believed to be cheaper and preferable to shop bending. The concrete is placed by a combined gravity chute and cart method as shown in the illustrations. With a 33 cu. ft. mixer the output of a single plant runs from 375 to 450 cu. yds. per day of eight hours, and three plants are in continuous operation.

Some of the quantities involved were originally estimated as follows, although the final figures may be slightly different:

Excavation .....	125,000 cu. yds.
Concrete in track slab and columns.....	36,300 cu. yds.
Concrete in footings.....	25,300 cu. yds.
Concrete in freight and office buildings.....	13,000 cu. yds.
Concrete in retaining walls.....	13,350 cu. yds.

which E. Pennington is president, and C. N. Kalk is chief engineer. The Leonard Construction Company, Chicago, has the contract, H. H. Hadsall having general charge of the design and construction for that company. The structural design was licensed and checked by the Concrete-Steel Products Company, Chicago, and H. Hanselmann, Chicago, is the architect.

The design and cost computations were made by the writer as consulting engineer for the Leonard Construction Company, and the design of the track slab was submitted to and approved by Professor W. K. Hatt of Purdue University.

### TELEPHONES IN TICKET OFFICES.

In our issue of August 8, page 214, there was given a summary of a large amount of information concerning the use of telephones in station ticket offices, the value of this service, the increased expense of running stations because of this comparatively new feature, and the problems connected with it. This information came from railroad officers in all parts of the country. To the matter there given there should be added a letter, received since that date, from the manager of a Western



View Under Track Slab Showing Typical Construction.

Concrete in driveway and pavements.....	17,700 cu. yds.
Concrete in entire structure, about.....	108,000 cu. yds.
Reinforcing steel .....	6,500 tons
Area of ground covered.....	18.5 acres (800,000 sq. ft.)
Area of working space.....	34.7 acres (1,500,000 sq. ft.)
Area of working space under roof.....	17.9 acres (780,000 sq. ft.)

The work is now being pushed at high speed, and it is expected that the terminal will be completed by January 1, 1914.

The entire deck of the track slab will be waterproofed by the Johns-Manville Company, using three-ply asbestos membrane protected by 1 in. of asphaltic mastic. In general the membrane will not be sealed to the slab, but will be entirely loose except at the downspouts and walls. About 630,000 sq. ft. of slab surface is to be waterproofed in this manner.

Arrangements are now being made to measure the actual stresses in the steel and concrete of the track slab, during the coming fall. Four adjacent panels will be loaded with locomotives and complete measurements made of the resulting stresses under various critical loadings. Dead load stresses occurring when the forms are removed will also be measured.

The terminal was planned by the M. St. P. & S. S. M., of

road which, though it contains little that is different from what was received from other roads, sets forth the small-station problem somewhat more in detail. This manager says:

"It is at the smaller one-man offices where the real difficulty exists. At such places, there is not only the freight and ticket work to look after, but the handling of railroad and commercial telegrams, train orders, baggage, express and mail. All this devolves on the agent, and he is usually a pretty busy man, especially at train time when his attention is required simultaneously in connection with nearly all classes of the work. It is clearly out of the question for him to give the telephone much attention at such times. This condition is generally quite well understood and appreciated by those who have frequent need of communicating with the agent, but, now and then others, who do not realize what the agent is up against, feel that they have a definite grievance and make vigorous complaint. If they cannot reach the agent quickly and talk with him at length and uninterruptedly, about matters of no special urgency, while others all around him need and are entitled to



preference, they feel it their duty to appeal to the superintendent—if not to the state railroad commission. This misuse of the service places a heavy burden on the agent.

"Many people in the smaller towns call up to inquire about trains with no motive or purpose but curiosity; or they desire to meet trains simply for the lack of something else to do. They also call the agent to get the correct time; or to inquire if there is any freight or express for them, just as they look for mail at the post office, without really expecting anything. In cases where they actually do expect something, they keep telephoning every little while about the shipment until it finally arrives. Endless other inquiries, too numerous and varied to mention, are also made, thus forcing the agent to become a veritable information bureau. All this seriously interferes with the transaction of the real business of the station. The best the agent can do in many cases, even with important questions, is to politely request the inquirer to give his number, or to call again later.

"We have arranged, in a number of cases, for the agent to keep the telephone exchange posted as to arriving time of trains, to enable the exchange operators to give out such information to the public upon inquiry, in order to save the agent from the burden of answering each inquiry himself. This has afforded quite a relief. The public should understand and appreciate these difficulties and endeavor to assist by reducing communication with railroad station telephones, both in frequency and length, as much as conditions will permit."

However, the agent's perplexities, whatever their character or degree, must be considered as a part of "the day's work" and, as was suggested in our former article, an agent may even make the telephone a stepping stone to personal advancement. The Missouri Pacific advises its agents on this subject in a code of rules, from which the following paragraphs are taken:

"The management regards the telephone service as the open door for the public's entrance and expects its representatives to extend the same courtesy to a patron's telephone call as though a personal visit were made.

"The public judges the company by the way you talk to it over the telephone.

"The word 'hello' is obsolete.

"Telephone calls should be answered promptly. Answer with the name of your department, or the name of the speaker, or with both if it would facilitate the understanding of the party calling.

"It takes just as much time later as now to answer telephone calls, therefore answer them *now*."

**COLOMBIAN RAILWAY EXTENSION.**—Construction work on the 60-mile extension of the Dorada Beltran Railroad will be commenced soon with a view to connecting with the Girardot Railway at Girardot, on the Magdalena river. As it parallels this river there should be few engineering difficulties. The completion of this road will do away with delays to freight and passengers on the upper Magdalena river, and will materially expedite the service between La Dorada, the present head of lower river steamboat navigation, and Bogota, the capital.

**NEW LINE FOR PORTUGAL.**—The Camara Municipal do Concelho de Thomar has just been authorized by the Portuguese government to build a railway from the station of Paialvo to the town of Thomar. The road is to be broad gage and similar to the government broad-gage lines. Thomar is to be the terminal of the contemplated Nazaré-Thomar Railway and is about 6 miles from the railway station of Paialvo. This railroad is necessary to make the Nazaré-Thomar Railway a complete success. Thomar is one of the show places of Portugal and is in one of the richest parts of the country. Concerns desirous of supplying material to the new railroad should communicate with the Camara Municipal do Concelho de Thomar and should write in Portuguese.

## WESTERN RAILWAYS DEMAND ADEQUATE COMPENSATION FOR PARCEL POST SERVICE.

Officers of a number of western lines on August 16, sent a telegram to Postmaster General Burluson, urging that steps be taken to secure to the railways adequate compensation for the service rendered by them in handling parcel post business. The telegram sent was as follows:

"The undersigned are prompted respectfully to ask you to consider whether the United States government is really dealing fairly with the railroads of the country as to the matter of pay in connection with the introduction and extension of parcel post service.

"The testimony of the Post Office department before the Senate committee, July 25, showed that the first three months' business of the department, after the installation of the parcel post, had a gross increase in postal revenue of 14.54 per cent. of which at least 9.16 per cent. was attributed to the new parcel post business.

"On the basis of this statement, the government must have collected not less than \$11,266,800 in revenue from the parcel post for the first six months beginning January 1. As this was before any arrangement had been made to reimburse the railroads for taking care of this new feature of the postal service, not one dollar of this big return was paid to any of the railroads for transporting the entire business referred to.

"To remunerate the transportation companies for the additional parcel post business transported, Congress provided, beginning July 1, a 5 per cent. gross increase in their mail pay, based upon rates, zones and weight limit, in original act, although the additional business transported amounted to at least 9.16 per cent., according to the testimony of the Post Office department or nearly double that provided in the allowance.

"The extension of the parcel post, to be inaugurated August 15, when the weight limit is to be raised from eleven to twenty pounds, and mileage increased, is certain to result in a vast enlargement of business.

"The government will collect postage on this business, but no provision has yet been made to pay the railroads for transporting it. Not only will they receive no compensation for this increased business, but will suffer the actual loss of earnings, previously derived from the same traffic when carried as express or freight.

"No code of business requires service without pay, and it is especially unreasonable for the United States government to require the railroads, or any other interest, to serve it without remuneration.

"Congress is in session and can immediately remedy this condition in accordance with suggestion made by the Committee on Railway Mail Pay in letter to you, July 30, which we endorse and urge upon your consideration."

The telegram was signed by the following: Darius Miller, president, Chicago, Burlington & Quincy; W. A. Garrett, vice-president, Chicago Great Western; W. L. Park, vice-president, Illinois Central; B. L. Winchell, director of traffic, Union Pacific; B. A. Worthington, president, Chicago & Alton; John Sebastian, vice-president, Rock Island; F. H. Britton, president, St. Louis Southwestern; E. L. Brown, vice-president, Denver & Rio Grande; R. H. Aishton, vice-president, Chicago & North Western; W. J. Jackson, receiver and general manager, Chicago & Eastern Illinois; E. F. Kearney, vice-president, Texas & Pacific; Edward Chambers, vice-president, Santa Fe; E. D. Sewall, vice-president, Chicago, Milwaukee & St. Paul; H. Miller, general manager, Wabash; C. E. Schaff, president, Missouri, Kansas & Texas; E. J. Pearson, vice-president, Missouri Pacific, and W. C. Nixon, receiver, St. Louis & San Francisco

# THE DARJEELING HIMALAYAN RAILWAY.

Many Difficulties Overcome to Enable This Two-Foot Gage Line to Climb the Himalayas on a Four Per Cent. Grade.

By LEWIS R. FREEMAN.

The Darjeeling Himalayan Railway, which has made the hill town of Darjeeling easily accessible from Calcutta, has rendered an invaluable service to the English in India by affording them a place of refuge from the excessive heat of the plains during the summer months.

Darjeeling is the summer capital of the province of Bengal. Lying on a ridge of the foothills of the Himalayas at an elevation of 7,000 ft. and in full view of the great 29,000 ft. peak of Kinchinjunga, it is, on the score of the grandeur of scenery, one of the most beautiful spots in the world. Up to 1878, when the

this section will be broadened to conform with the line from Calcutta. The 51 miles of the Darjeeling Himalayan Railway, from Siliguri to Darjeeling, are of the 2 ft. gage.

The Ganges ferry on this run has presented one of the most troublesome problems in Indian engineering. Owing to the shifting nature of the great river, which cuts away its bank at one point and increases it at another, the ferry slips have had to be moved back and forth up and down both banks, often as much as several miles at a time. The completion of the great bridge at this point, preliminary work on which has been going on for



A Sharp Loop in the Himalayas.

northern Bengal State Railway was opened to traffic, the journey from Calcutta to Darjeeling was a formidable undertaking of a week's duration, involving travel by rail, steam ferry, block cart and a pony-drawn tonga. The completion of the line from Siliguri to Darjeeling in 1881 established rail connection all the way to the coast, and repeated improvements in train and ferry schedules have cut the running time between Calcutta and the mountain terminus down to 20 hours. There are three grades of gage. From Calcutta to Damoodeah, on the Ganges, a distance of 116 miles, the way is over the tracks of the Eastern Bengal State Railway, which is of the Indian broad gage of 5 ft. 6½ in. The 196 miles of the same railway from Sara Ghat, on the northern side of the Ganges, to Siliguri, are of the 3 ft. narrow gage, but, on the completion, of the great Ganges bridge,

several years, promises to put an end to this trouble, though it is by no means impossible that the capricious river may alter its course in some great spring flood of the future and leave a \$15,000,000 bridge spanning a dry channel.

The line from Calcutta runs across the low valleys of the Ganges all the way to the foot of the Himalayas, and Siliguri, 329 miles from the coast, has an elevation of but 400 ft. above sea level. At this point the final change is made to the mountain railway and the average grade of the remaining 50 miles to Darjeeling is 4 per cent. When first built the line followed very closely the route of the old cart road and the average grade was over 5 per cent. Subsequent reconstruction and alinement necessitated many loops, spirals and switchbacks before the grade was reduced to its present 4 per cent. The cost of the road as

it now stands, inclusive of roadbed, rolling stock, stations and staff quarters is about \$18,000 per mile. The percentage of net earnings on total capital has varied between 9.02 in 1901, to 11.65 in 1910. The earnings are augmented by an annual subsidy of about \$30,000, and for several years stockholders have received an annual dividend of 10 per cent., a good figure even for India, where all of the railways are good payers.

Like all Indian trains, those of the Darjeeling Himalayan provide for the carrying of three classes of passengers. The first class coaches are divided into two compartments, and are 13 ft. long by 6 ft. wide and 7½ ft. high above the rails. The diameter of the wheels is 19½ in., and the floors clear the ground by but a few inches. They carry 12 passengers, but are hardly comfortable with more than half that number. Luggage of the size of an average suit case or larger has to be checked and carried in the baggage van. First and second class compartments are identical

the first loop is circled. From there until the summit of the ridge above Darjeeling is reached at Ghoom, 7,500 ft. above sea level, loops, switchbacks and "horseshoes" succeed each other in rapid succession. As the line reaches the first ridge and begins to clear the forests, glimpses of the plains appear, and, if the sun is right, the flash of the distant Ganges may be seen, and even the Brahmaputra in Assam. The plantations commence as soon as the forest zone is passed and the line, which has been of inestimable value to them in providing a regular outlet for their crops, is hemmed in by the dark green tea bushes most of the way to Darjeeling.

The first of the switchbacks is encountered at mile 17, and so abrupt is the hillside that the passenger may step out of his car at the foot and, following the footpath, easily beat the train as it is slowly shuttled back and forth to the top.

There is nothing approaching a level space of even an acre



Himalayan Terminus of the Darjeeling Railway.

in appointments, the only difference being that passengers of the latter class are not allowed in the compartments of the former, and one is therefore less likely to be crowded in the first class. Fares are high, though not unwarrantably so for a mountain railway. First class costs the equivalent of about 12 cents a mile; second class, 6 cents; and third class, about 2½ cents. The average fares in India are first class, 4 cents; second class, 2 cents, and third class, from ½ to ⅔ of a cent.

The first 7 miles of the Darjeeling railway extend through the dense sub-tropical forest which clothes the lower slopes of the Himalayas. Especially noticeable among the timber trees is the Sâl, the main source of India's tie supply. Deodar, another Himalayan tree, is also much used for this purpose, and teak is sometimes employed, though its value for ship building and other finer construction makes it rather too valuable to use for ties. From the seventh mile the climb begins, and at the twelfth

in extent anywhere on the line, but Teendharia, at mile 20, offers a less abrupt slope than any other point, and out of this has been terraced space for workshops and roundhouses, and this spot forms the principal locomotive station.

At Gybari station, at an elevation of 3,500 ft., a long series of switchbacks occurs, a portion of which have proved very troublesome to protect at the height of the monsoon or in any season. When it is stated that the precipitation has been known to exceed 14 in. in 6 hours at this point, something of the difficulty of preventing washouts may be realized. The last of the four loops is passed just before reaching Gybari. The work of constructing this "spiral" was extremely difficult and expensive, as the curve has a radius of but 58 ft.

At mile 25 the geological formation changes to what is known as "Sikkim gneiss," and thenceforward the line is less liable to damage from flood. Kurseong, a resort for the

stand the altitude and humidity of Darjeeling, is reached at mile 30, and from there the 2,500 ft. climb to Ghoom, 16 miles farther on, follows closely the route of the cart road, the grade being as high as 4.3 per cent. in places. Beyond Ghoom, the line sweeps around a point into full view of the snows on the Himalayas, and, still following the cart road, descends the last 4 miles to the narrow ledge upon which are located the Darjeeling yards and station.

It is interesting to note that, despite the diminutive size of the trains, the management has contrived to light the expresses with electricity. The lighting plant is carried on a separate car, and consists of a 6 h. p. gasolene motor, direct coupled to a dynamo with a capacity of 54 amp. at 65 v. The current is carried by cables fixed to the roof of the cars, joined by couplings. No accumulators are needed, the current being generated and carried direct to the lamps.

The management has furnished the following brief descrip-



Switchback on the Darjeeling Himalayan Railway.

tions of the two classes of specially designed locomotives which are used on the Darjeeling Himalayan Railway:

"Garratt" Engine.		Class B Engine.	
Type	0-4-0	0-4-0	0-4-0
Cylinders	1 in. x 11 in. x 14 in.	2 in. x 11 in. x 14 in.	2 in. x 11 in. x 14 in.
Steam pressure	160 lbs. per sq. in.	140 lbs. per sq. in.	140 lbs. per sq. in.
Wheels, diameter	26 in.	26 in.	26 in.
Weight of engine in working order.	28 tons	14 tons	14 tons

Two extensions of this line are now under consideration. The Teesta Valley extension would run from Siliguri, practically on the level 11 miles to Sivok, and then up the Teesta valley 18 miles, a total of 29 miles. The last 18 miles would present difficulties such as were encountered in the construction of the Darjeeling Himalayan Railway. The Kissengunge extension would run from a point at about mile 4 of the Darjeeling Himalayan Railway directly west to Nuxalbari, on the Nepal frontier, and thence in a southerly direction to Islampur and Kissengunge, 72 miles. There would be no engineering difficulties of any extent on this line. It is believed that the traffic would be large enough on both extensions to warrant their construction.

**ARGENTINE RAILWAY CONCESSIONS.**—The public works committee of the chamber of deputies of Argentina has reported favorably on the following bills: A concession to the Central Argentine Railway for a line from Vinas to Puerto Ramallo. A concession to the Buenos Aires Western Railway for a line from Colonia Alvear station, in a westerly direction across the Atuel river, passing about 37 miles through the Province of Mendoza and terminating at Colonia Bouquet. A concession to the Compañía Francesa de Ferrocarriles en la Provincia de Santa Fe for a line from Charaday station westerly for 60 miles.

## TRAIN ACCIDENTS IN JULY.<sup>1</sup>

Following is a list of the most notable train accidents that occurred on railways of the United States in the month of July, 1913:

<i>Collisions.</i>						
Date.	Road.	Place.	Kind of Accident.	Kind of Train.	Kil'd.	Inj'd.
†11.	I. S. & M. S. .... } Pennsylvania .... }	Alliance.	xc.	P. & F.	1	62
13.	Mich. Central .....	Jackson.	bc.	P. & P.	0	8
21.	Great Northern .....	Superior.	xc.	F. & F.	6	5
26.	Southern .....	Holton, Ga.	bc.	P. & P.	1	2
27.	Lehigh Valley .....	Rockdale.	rc.	F. & F.	1	15
30.	Pennsylvania .....	Tyrone.	rc.	P. & P.	1	11
31.	Great Northern .....	Allouez.	xc.	P. & F.	2	2

<i>D. Derailments.</i>						
Date.	Road.	Place.	Cause of Derailm't.	Kind of Train.	Kil'd.	Inj'd.
2.	Missouri Pacific ....	Berger.	d. eq.	P.	1	108
11.	Southern .....	Wayne.	malice.	P.	2	0
13.	Mich. Central .....	Detroit.	unx.	F.	1	0
18.	Texas & N. O. ....	Fauna.	boiler.	P.	2	..
26.	Chi., M. & St. P. ....	Cataline, Wis.	acc. obst.	P.	4	1
26.	Denver, B. & W. ....	Eldora.	neg.	P.	0	19
27.	Erie .....	Paterson.	neg.	F.	4	3
30.	Georgia S. & F. ....	Fargo, Ga.	unx.	P.	0	10
30.	Cin., N. O. & T. P. ....	Glenmary.	b. rail.	F.	3	0
†30.	Lancaster & C. ....	Knox, S. C.	flood.	P.	2	55
31.	Louisville & N. ....	Livingston.	unx.	P.	2	10
31.	Philadelphia & R. ....	Sinking Spring.	unx.	F.	1	4

The collision at Alliance, Ohio, on the evening of the 11th, was caused by six freight cars running away after having eluded control while being switched. These cars broke away from a yard train of the Lake Shore & Michigan Southern and ran uncontrolled some distance down grade to the crossing of the Pennsylvania, where they crashed into a coach of passenger train No. 340. One passenger was killed and 58 passengers and four employees were injured. The yard engine had come down from Mount Union to the freight house with five cars ahead of the engine, the engine moving tender first. These five cars were left standing on the main track, with two hand brakes set, while three cars were taken out of the freight house track and coupled to the five cars, making eight cars in all. After the train had proceeded some distance, the conductor and brakeman discovered that four cars had broken away, but before they could set the brakes the cars ran down the grade and collided with the passenger train which was pulling over the crossing, striking the coach in No. 340 near the center.

The collision near Jackson, Mich., on the 13th, occurred on the bridge over Grand River. Northbound and southbound passenger trains, running at 25 or 30 miles an hour, collided with such force that the engines and first two cars of each train were derailed and the tender of one train and the baggage car of the other fell into the river. The northbound train had run past the meeting point fixed in a despatcher's order. One engineman, one fireman and six passengers were injured.

The trains in collision at Holton, Ga., on the 26th, were northbound passenger No. 13 and southbound passenger No. 24. A porter was killed and the engineman and fireman on train No. 24 were injured. The collision was due to the mistake of the porter, who was killed, in turning a switch immediately in front of train No. 24. When that train was within 300 ft. of the siding on which No. 13 had been placed to meet No. 24, he became excited because of the apprehension that the switch was not in the right position and he turned it, allowing the train to enter the side track. The porter was struck by the engine and instantly killed. Both engines were badly damaged, but no passengers

<sup>1</sup>Abbreviations and marks used in Accident List:  
rc, Rear collision—bc, Butting collision—xc, Other collisions—b, Broken—d, Defective—unf, Unforeseen obstruction—unx, Unexplained—derail, Open derailing switch—ms, Misplaced switch—acc. obst., Accidental obstruction—malice, Malicious obstruction of track, etc.—boiler, Explosion of locomotive on road—fire, Cars burned while running—P, or Pass., Passenger train—F, or Ft., Freight train (including empty engines, work trains, etc.)—Asterisk, Wreck wholly or partly destroyed by fire—Dagger, One or more passengers killed.

were seriously injured. The switch was right, before the porter touched it, train 13 having entered by another switch.

The trains in collision near Rockdale, Pa., on the 27th, were eastbound freights. The leading train had stopped at a water tank when the following train, running fifteen miles an hour, collided with it. The engineman of the following train failed to properly observe signals set against him. The caboose and four cars of the leading train were wrecked. The conductor, riding in this caboose, was killed. A part of the wreck fouled the westbound track and passenger train No. 5, which came along very soon after, ran into it and the engine and two cars were derailed. The fireman of the standing freight train flagged the passenger train and its speed was reduced considerably. Fifteen passengers were slightly injured.

The trains in collision at Tyrone, Pa., on the 30th, were westbound first class trains No. 13 and No. 15, No. 13 running into No. 15 as it stood at the station, or was just starting away. The engineman, Geo. J. Funk, of No. 13, was killed and a large number of passengers in No. 15 were injured. Eleven of these injured, including a number of employees in the dining car, were taken to a hospital, but in the other cases the injured ones were able to continue their journeys. A number of officers of the road were on train No. 13, and they at once began an investigation to discover the cause of the collision; and they reported in substance as follows:

"The track inspection committee rode in car 2802 on the rear of train No. 13, which ran into the rear of train No. 15, standing at Tyrone passenger station. We at once investigated the cause of the accident and found it was due to the engineman, Funk, disregarding caution and home automatic signals. The flagman of No. 15 had been called in and had almost reached his train when No. 13 came in sight. We found him standing at the rear of our car; in other words he was a train length to the rear of his train when we saw him.

"He stated that automatic signal No. 2,219, which was 1,150 ft. to the rear of train No. 15, had been in the stop position. This was verified by the traveling engineer of the Tyrone division. Signal Engineer Rudd, and supervisor of signals Post, examined the signal mechanism and found it in perfect condition."

When the locomotive of No. 13 was examined it was found that the emergency brakes had been applied by Engineer Funk and that he had reversed the engine.

The wreckage was piled across three tracks, but all of the cars in both trains were of steel and withstood the shock with but little crushing. No. 13 had eight cars, and was running on time and going about 30 miles an hour. The impact threw the locomotive off the track and against the railroad fence, three cars following.

The front mail car in No. 15 was overturned while the seven cars behind it stood the shock and remained on the rails. On the locomotive of No. 13 were Engineman George K. Funk, Fireman W. D. Barton and Assistant Road Foreman of Engines C. E. Miller. Funk was crushed against the railroad fence and instantly killed; Miller suffered a fractured skull, and the fireman escaped with slight injuries. Most of the passengers in the last two cars of train No. 15, which received the worst of the shock, were thrown from their seats and more or less bruised and cut, while there was scarcely a car of either train that did not contribute its quota of injured.

The accident at Allouez, Wis., on the night of the 31st, was due to carelessness in switching. A train of ore cars was allowed to run violently against a standing train on which were a number of workmen, and eight of these men were thrown into the ore pockets, where they were covered with ore and badly injured. Two of them were killed and 2 others seriously injured.

The train derailed near Berger, Mo., on the 2nd was the westbound California express and the engine and seven cars were overturned and fell down a bank. The engineman was killed and 104 passengers and 4 employees were injured. The derailment is believed to have been caused by something dragging under the engine.

The train derailed at Wayne City, Ill., on the 11th, was westbound passenger No. 24. The engineman was killed and the fireman fatally injured. The engine was derailed by a bolt which had been placed on the track by mischievous boys, and the engine was ditched.

The train derailed near Detroit, on the 13th, was an eastbound first class train consisting of empty baggage cars. The engine was derailed and overturned, and the engineman was killed. The leading truck of the tender was the first to leave the track.

The train derailed near Fauna, Tex., on the 18th, was a westbound passenger, and the cause of the derailment was the explosion of the boiler of the locomotive. The engineman and fireman were killed.

The train derailed at Cataline, Wis., on the 26th was a southbound express. The engine and first three cars were badly wrecked. The engineman, fireman, express messenger and one other person were killed and one trainman was injured. The cause of the derailment was a tree which had been blown down by a high wind and lodged on the track.

The train derailed on the Denver, Boulder & Western at Eldora, Col., on the 26th, was an excursion passenger which had just been loaded for its trip to Denver. The train was pushed backward around a Y-track, preparatory to starting, and the rear car was pushed over the bumping post. In trying to pull the car back on to the track it was overturned and this coach in turn pulled over two others, and 19 persons were injured.

The train derailed near Paterson, N. J., on the 27th, was a work train moving at low speed around a curve of 3 deg. One car was overturned and fell down a bank, and four laborers riding on this car were killed, and three were injured. The derailment was due to the unbalanced load on the car, which contained cinders. The lading on the high side had been taken off.

The train derailed on the 30th near Fargo, Ga., was southbound passenger No. 1, and the first three cars were ditched and overturned. Four passengers and 6 employees slightly injured. The tender was the first vehicle to leave the track.

The train derailed at Glenmary, Tenn., on the 30th, was southbound freight No. 51, and the engine and 19 cars fell down a bank. The engineman, fireman and one brakeman were killed. The cause of the derailment was a broken rail.

The train derailed on the Lancaster & Chester near Knox, S. C., on the 30th, was a mixed passenger and freight. There were two passenger cars, both of which fell through a bridge and lodged in a creek 50 ft. below. Two passengers were killed and a large number of passengers were injured.

The train derailed at Livingston, Ky., on the 31st was southbound passenger No. 23, and the engine and first three cars were overturned. The engineman and fireman were killed and the six passengers and four trainmen were injured. The cause of the derailment was not determined.

The derailment of an eastbound freight train at Sinking Spring, Pa., on the 31st was at a derailing switch. One brakeman was killed and four other trainmen were injured. The engine and 18 cars ran off. The derailment was due to the carelessness of a signalman who changed the signal when it was too late for the train to stop.

*Electric Roads.*—In a rear collision on the Pacific Electric Railway near Los Angeles, Cal., July 13, 14 passengers were killed and about 150 injured. This was reported July 18, page 119. On the same day, the 13th, four persons were reported killed at Cambridge, Ohio, when an interurban electric car was struck by a passenger train. In a rear collision on the Rochester & Eastern at Victor, N. Y., on the 19th, one passenger was killed and eighteen were injured. A freight train ran into the rear of a preceding passenger train.

**PROPOSED LINE FOR CUBA.**—A railroad is projected from Placetas, Cuba, to Trinidad, Santa Clara Province. Trinidad is one of the oldest towns of Cuba and one of the most picturesque. It is, however, entirely cut off from railroads and has thus lost much of its importance. Digitized by Google

# TRAVELING ENGINEERS' ASSOCIATION.

Operating Department and Fuel Economy; Superheaters; Brick  
Arches; Smoke Prevention; Locomotive Brake Equipment.

The twenty-first annual convention of the Traveling Engineers' Association was held at the Hotel Sherman, Chicago, August 12-15, with President W. H. Corbett, master mechanic, Michigan Central, in the chair, as noted in the *Railway Age Gazette* of August 15, page 273. The opening address was made by W. A. Garrett, vice-president, Chicago Great Western.

## MR. GARRETT'S ADDRESS.

Mr. Garrett showed that he thoroughly appreciated the service rendered by the road foremen of engines and was conversant with their duties and the various problems that they have to solve. He referred to them as the men upon whom rested the responsibility, which under present conditions is a very important responsibility, of seeing that the engines are operated with the greatest economy and with the least amount of failures. Every year has found an improvement in the engineers and firemen, which is due to the painstaking and conscientious manner in which the traveling engineers train and instruct these men.

Mr. Garrett also laid special stress on the relation of the employer towards the employee, stating that the success of the employer depends upon the well-being and high standing of his employees, and again, the success of the employees depends upon the success of the employer, which necessitates a thorough cooperation between them. Mention was made of the effects of government regulation whereby it has become so hard to make the necessary profits. It, therefore, devolves on the employees as well as the management to reduce the operating costs as much as possible. Otherwise, the roads will be driven to receiverships which may eventually develop into government ownership, a thing which neither employees nor the railroads desire.

Mr. Garrett quoted from statistics compiled by the Interstate Commerce Commission as to the causes of the principal accidents that occurred between 1902 and 1912 as follows:

Excessive speed .....	137
Carelessness .....	95
Mis-read order .....	69
Ran past signal .....	66
Disobedience of rules on orders.....	63
Forgetfulness .....	49
Asleep .....	40
Failure to follow schedule.....	16

535

He closed his remarks by calling attention to the importance of the "safety first" movement and cautioned the men to make haste safely.

## ADDRESS OF THE PRESIDENT.

President Corbett spoke of the responsibilities of the road foreman of engines, as he is the man to whom the engineers and firemen look for final instructions on matters pertaining to locomotive operation. He should be most thoroughly trained in economical and safe locomotive operation, and should study the new devices as they are placed on the locomotive in order to obtain the best results from them. He should also keep posted as to the various appliances that improve locomotive operation. The railroads at present are trying to solve the difficult problem of the "high cost of living" and every new idea that will increase economy in locomotive operation will be gladly accepted.

## MR. TOLLERTON'S ADDRESS.

W. J. Tollerton, general mechanical superintendent of the Rock Island lines, said in part: I regard this association as one of the most important of the various mechanical organizations; it is alone from the vigorous effort which must be put forth constantly to reduce the growing operating cost, but also from the requirements of the various federal and state laws, cover-

ing locomotive conditions. Therefore, I feel that the position of traveling engineer is one of large responsibility. You gentlemen have direct supervision over a large part of locomotive operating expenses, proportioned about as follows:

Locomotive fuel, including handling.....	43 per cent.
Locomotive repairs .....	24 per cent.
Engine house expense .....	6 per cent.
Water for locomotives .....	2 per cent.
Lubricating locomotives .....	1 per cent.
Locomotive supplies .....	1 per cent.

The traveling engineer's principal duties are those of education and instruction. The greatest returns will be secured by educational means; discipline should be administered only in extreme cases of unwillingness to follow your instructions. Discipline freely administered indicates lack of proper instruction, disorganizes your division and should be avoided.

That the personnel of your engine service may be brought to the highest efficiency, care should be used to secure the right kind of locomotive firemen. Young men, with at least a grammar school education, should be selected. And when started out they should be thoroughly instructed along the lines of proper and economical performance of their duties. A number of roads issue instruction books; on the Rock Island the first year's questions and instructions cover combustion; second year, the handling of the locomotive, break-downs, etc.; and third year, the air brakes and signals. These books should be placed in the hands of young firemen and their details discussed at class meetings. The fireman of today is the engineer of tomorrow, and a careless and indifferent fireman will always develop into that kind of an engineer. Hold frequent meetings with the engine crews. At such meetings investigate and explain factors directly affecting economy in operating costs; discuss rules and other matters which enter into the everyday life of enginemen.

The federal boiler inspection law is being strictly enforced; therefore, it becomes your duty to see that all defects in violation of this law are properly and intelligently reported by the enginemen on arrival at the terminals. Not giving proper and accurate reports calls for greater expense in roundhouse maintenance. Incomplete work reports result in the mechanics spending hours trying to locate defects, which time could be devoted to making needed repairs to other locomotives, thereby reducing one of the growing costs of locomotive operation, i. e., locomotive repairs. Correct reports made by the enginemen will enable the roundhouse forces to quickly make the repairs to the defective parts, reducing the time the locomotives are at the terminals. Under the present practice of pooling, particularly freight locomotives, it is most important that the enginemen be instructed as to the proper and accurate work reports to avoid unnecessary expense. Enginemen in pooled service have a tendency to avoid reporting work, possibly with a view of not being criticized. This can be overcome by proper instruction.

Fuel represents 42 per cent. of the expense of locomotive operation. Repairs represent 24 per cent. Those two items afford the best opportunity for reducing the operating expenses, and it is to you that the management has to look for the results. These can be obtained if you get the enginemen thoroughly interested. Members of this association should not only be familiar with the requirements of the federal boiler inspection law, and the penalties for violations thereof, but should instruct the enginemen as to their duties therewith. The importance of the inspection of locomotives should be impressed on the enginemen. It is true, the railroads maintain locomotive inspectors at larger terminals; on branch lines and other places the inspection force consists of the enginemen

themselves. The proper amount of interest by the enginemen will reduce the engine failures and improve the service.

You can assist greatly in making the "Safety First" movement a magnificent success. The number of injuries annually to enginemen, due to broken water and lubricator glasses, may practically be eliminated by the enginemen insisting on shields being properly maintained. Explain to them that it is to their interest to properly report shields, headlights, air brake apparatus, safety appliances and similar defects that may cause injury to themselves or others. Follow this closely, as it is one of the largest possibilities in the safety first field. Eliminate the overloading of locomotive tenders. This will not only assist in avoiding injury but will save fuel.

Be familiar with and fully instruct the enginemen as to the requirements of the Interstate Commerce Commission on safety appliances, in so far as they relate to the locomotives. There are two disbursements for which every railroad company receives no return. They are payments for personal injuries and losses due to fire damage. You can aid greatly in bringing these down to a minimum. With proper co-operation on the part of the firemen, in closing the damper after blowing the ashpan, and the enginemen in seeing that all appliances are in proper working order before leaving terminals, a large reduction can be made.

#### W. L. PARK'S ADDRESS.

W. L. Parks, vice-president of the Illinois Central, spoke of the traveling engineer as being indispensable in the present method of locomotive operation. He commented at some length on the opportunities of the men in the operating department, such as the traveling engineers, to greatly aid in directing public opinion along the right lines in regard to the railroads. He showed by general statistics the number of women and small shareholders holding stock in the various large railway companies. In some cases over 50 per cent. of the stockholders had a hundred shares or less. At the present time the railroads are in hard straits, finding it difficult to borrow money as freely as before. Confidence seems to have become shaken and men connected with the railroads should do all they can to convey the true facts to the public and let them know who the true owners of the railroads are. As regards accidents, Mr. Park stated that 114 were killed in passenger accidents in the United States during the past year, whereas about 6,000 trespassers were killed. The law makers should use more influence to keep these people from off the right of way. In regard to obnoxious laws in this respect, he cited those in effect in the state of Mississippi, where trains are required to slow down to a speed of 6 miles an hour while passing through towns and cities, and wherever a trespasser is hit in this state considerable trouble is experienced on account of this law. Engineers, having been indicted, are becoming personally interested and are using their influence to have such laws changed. Mr. Park also mentioned the beneficial effect the railway supply companies are exerting in locomotive operation by their special investigations of various new devices to increase the economy of railroad operation.

#### THE OPERATING DEPARTMENT AND FUEL ECONOMY.

For the purposes of this report the committee assumes the operating and mechanical departments are to be considered as distinct units. The operating department consists of officials usually known as general superintendent, superintendent of transportation, division superintendent, trainmasters, train despatchers, yardmasters, etc., or those who have to do with making up and despatching trains. The consumption of fuel per ton mile is variable and dependent on many conditions, two of which come within the province of the operating department. When power is ready for service, the fuel burned while it is waiting to be utilized might be considered by the strict economist as being wasted, as no direct earnings result from its use. Fuel burned during time beyond that in which the train

should be delivered at its destination under the average favorable conditions, might also be considered wasted. The relation which the operating department has to economical consumption of fuel lies in its control of the above two items through its connection with power utilization and its supervision of train movement.

The study of fuel economics is scarcely a duty of the operating department, but moving trains and handling power in connection therewith are its chief duties and upon the efficiency with which it performs these functions, a low or high fuel consumption largely depends. Its opportunities for aiding in keeping down fuel consumption through betterment of many underlying conditions, well within its charge, that have an indirect bearing on the promptness with which power can be utilized and trains made up and delivered, are far from limited. Credit is due it for the betterments that result in actual savings in fuel and for endeavors to take advantage of opportunities tending to further savings. The true credit due is proportional, however, to the utilization it makes of these opportunities as a whole, considering possible savings that could be made if all were taken advantage of. Paradoxical as it may appear, a seemingly low fuel consumption per ton mile may actually be a high consumption, and the maximum amount that should be used may be less than the minimum amount being used through adverse conditions of operation which might be reduced to a minimum if proper efforts were made. For illustration: Two railroads run side by side, under the same basic conditions as to gradient, style of power, etc. On one line the fuel consumption per thousand ton miles has been 175 lbs., which, by a supposed strenuous effort of the operating department, is reduced to 170 lbs. The general manager boasts to the general manager of the competing line of this record and is informed that the fuel consumption per thousand ton miles on the competing line is but 150 lbs. He finds the difference is due to such things as closer tab kept on reducing power in dull times, better judgment in assigning engines to the runs suited them, more attention to trackage at turn-tables, ash-pits and coal chutes, up-to-date methods of handling the ashes and coal to prevent delays, yards modified from time to time to expedite switching and the making up of trains, block signals arranged so as to be seen a good distance away, close supervision of despatching methods to prevent delays, rigid investigation of delays and prompt action to eradicate causes leading thereto; close attention to methods of inspection to prevent having to switch out bad order cars in terminal yard and en route, scientific loading in relating to the capacity of the power and weather conditions, judgment in regard to cutting down and filling out en route, and in seeing to proper facilities for quick switching at such points; judicious selection of stopping and starting ground at the water stations and at block signals where conditions may make stops frequent, and to betterments of similar imperfect operating conditions, most of which were within the power of his operating department to have bettered.

Even where yard and road conditions are ideal, a good share of credit can accrue to the operating department for fuel savings through intelligent handling whereby trains are made up with least possible delay, handled with minimum amount of power, gotten over the road in the minimum of time, and power held at terminals the shortest time possible consistent with keeping up necessary repairs and with the volume of business.

The most deserved credit that can be given the operating department for results that bring about economy in fuel is that due for betterment in yard and road conditions and in methods of despatching that go to make nearly perfect railroading.

*Limitation of Power Kept in Actual Service.*—We assume that practically the maximum number of engines required to handle business at its height is assigned to each division. Good judgment in shopping engines for repairs and in storing them during the dull periods is an important item in fuel economy. We do not believe in limiting engines kept in s-

ice to a point that might delay freight through lack of power to move it, but while any train or number of trains may be moved with a low rate of fuel consumption when only fuel used in actually moving is considered, yet all fuel consumed by the engines of a division must ultimately be charged against the total train movement of such division, and engines needlessly lying ready for service and consuming fuel in idleness increase the fuel consumption per ton per mile above the figure used in actually handling tonnage. The same is true of power held on the road beyond what would be a reasonable time under favorable conditions, when such delay is due to indifferent operating conditions. It is realized that delays are not always chargeable to the operating department, but the closer the final charges for fuel consumed are to the number of pounds per ton mile used in actually handling the train, the greater will be the credit due that department.

In storing engines, we believe in keeping those in service whose mileage comes nearest entitling them to shopping. If the poorer engines are stored, the good ones are being worn out during the dull season, and when the rush season comes the majority of the power will be in poor condition. With poor power in use during dull periods, the tendency of such power to break down is not as likely to cause delay to following trains, with accompanying waste of fuel, as in the busy season when the trains run closer together.

*Turning of Power.*—The operating department has a direct interest in facilities for speedily turning engines at terminals. Whether it is in direct charge of the turning or not, it is entitled to credit for aid in procurement of betterments that make quick turning possible with an accompanying economy in fuel. This calls for a good arrangement of trackage to and from the yards to the turn-table, ash-pit, coal chutes and water tank, and a sufficient and efficient turn-table, ash-pit, coal chute and water crane arrangement whereby, particularly at busy terminals, a more or less continuous "blocking up" condition is avoided.

*Yards—Terminal, Intermediate and Hump.*—Yard conditions, terminals and en route, are perhaps the most prolific source of train delays that result in increased fuel consumption. Terminal yards should be large enough to permit prompt entrance of the incoming trains and provide for a quick movement of power to the engine terminals. Yards at intermediate points should provide for speedy switching where necessary to pick up or throw out cars and for prompt obtainance of water and fuel when necessary. At large terminals, separate yards for making up trains going in opposite directions, classification tracks in connection with making up, provision for proper storage tracks, cripple tracks of easy access into which bad order cars may be thrown for repairs, which are to be used exclusively for this purpose; and "making up" tracks, long enough to hold maximum length of trains hauled, thereby avoiding switching incidental to making up on two tracks, all tend to promptness of train movement and the minimizing of fuel consumption. Provisions to accelerate movement of road engines to waiting trains, avoidance of switching movements by the road engine after coupling to the trains, as in throwing out bad order cars, filling out, etc., and provisions for the prompt get-a-way of trains, are equally important. Hump yards are an efficient means of reducing fuel charges in switching service by reducing switching power. Experience is teaching, however, that unless closely watched they not only run up the car department costs, but are not as conducive to fuel economy as might be, due to the failure of yardmasters at some points to see that the cars are not prevented by riders, from striking with sufficient force to damage them. This frequently results in delays due to making repairs or throwing out badly damaged cars and is believed to be a material cause of break-in-twos en route.

*Loading of Power.*—Proper loading of power as to capacity is important to prompt train movement and fuel consumption. We believe that power should be loaded to not more than 90 per cent. of maximum capacity under the best conditions and that this be

varied according to the weather conditions. As a matter of fact, fuel is sacrificed by unloading as well as overloading. Where a grade on the division is not sufficient to justify pusher service, if trains were loaded so to make certain they would not stall on such grade they would be underloaded over the rest of the division, causing considerable loss in ton miles and increased fuel consumption per ton mile. Local conditions should be carefully studied to determine the most economical load for the territory. Makeup of trains as regards heavy and light cars is important, as the further from the engine the heavy cars are, the more the flange friction is increased on the curves and the harder the train will pull. Efforts should be made to place the heavy cars at the head end of the train. Judgment, however, should be used in order not to bring about bad braking conditions.

*Train Inspection.*—While train inspection is not usually directly in the control of the operating department, it bears such an intimate relation to train movement that this department is vitally interested in it. Prompt inspection of the trains, the providing of adequate facilities for such inspections, for making light repairs, for throwing out bad order cars, for inspection and testing of the air brakes before the road engine is attached, or arrangements for a quick test after it is attached, are of direct benefit to it, and incidentally to fuel economy.

*Watering and Coaling En Route.*—Water troughs permitting the water supply to be scooped are an efficient means of lowering fuel consumption by cutting out train delays incidental to stopping for water. Where water cranes are used, special attention should be given to the lay of the ground in the immediate vicinity with reference to the ease with which the trains can be stopped and started in either direction and when located in the yard limits they should be so arranged that the trains, while standing, will not block switches, cross-overs or public highways, or interfere with other power movements. Water tanks should be spaced so that heavily loaded trains can get over the division with a minimum number of stops for water. In bad water districts water treating plants should be installed. Where necessary to take coal en route, facilities should be provided so as to avoid unnecessary delays or interference with the movements of others or permitting such other movements to delay the quick coaling of through-going power.

*Block Signals.*—Where block signals are in use they should be so located as to be seen at a reasonable distance away from the approaching train, preferably on the engineer's side, and they should be carefully maintained. Being required to reduce speed on account of not being able to see the signal until almost at it, to avoid running past if set against train movement, is not an uncommon cause of slow movement and, therefore, not conducive to fuel economy. In congested districts, where stops are likely to be frequent, location of signals with a view to good starting ground, is of importance. Automatic block signals are decided improvements over mechanical or hand-thrown signals, on account of being closer together, enabling the inferior train to occupy the main track closer to the time of the superior train and to start out closer behind the superior train, thus bringing about more prompt train movement and less delay in allowing superior trains to pass, which results in fuel saving.

*Train Despatching and Handling of Train Orders En Route.*—Handing train orders from towers without requiring the train to be brought to a standstill, is important to prompt movement. In automatic block territory on ascending grades, heavily loaded trains should be allowed to proceed under caution instead of coming to a full stop. In a manual block territory on ascending grades, caution cards should be handed on by hoops instead of stopping the train. The use of telephone boxes at outlying points for the purpose of directing crews with reference to train movement, is also a distinct aid and source of credit to the operating department. Utilizing the track against the current of traffic can be frequently done to good advantage.

*Way Freight Trains.*—Local way freight or pickup trains, where conditions warrant such, for distributing freight from the terminals to the local points, attending to local switching, gathering



up local freight and bringing it to the terminal points to be made into through trains, thus avoiding delay in stopping the through trains for these purposes, is also a means of cutting down fuel consumption. Where work on the division is more than local trains can do, the accumulation should be switched to some point on the division where it may be readily picked up by a through train stopped for that purpose.

*Poolled or Assigned Power.*—Whether it is best to pool power or assign each engine to a regular crew, is a problem important to fuel economy. Admitting that a regular assigned engine is given more attention by the engine crew, may get out on time more frequently, and with a good engine crew may perhaps cost less for maintenance, yet with the growing tendency to take the responsibility of the repairs made on engines from the engine crew and placing it on the shop, the advantages of assigned engines are becoming less. The sixteen-hour law makes it practically impossible for an engine crew to follow an engine unless the engine is held a long time at terminals, which cannot be thought of when yards are congested. If the engine is not held, the engine crew that brought it in may not see it again for a week, which practically places the engine in pooled service. If men could, as formerly, follow their engine with whatever rest they themselves considered sufficient, the assigned engine would be ideal. If engineers on pooled engines were educated to take the same interest in promptly and intelligently reporting work on every engine brought to the terminal and were held strictly accountable for reporting all defects, and the shops were required to do the work reported, there would be little, if any, advantage in the assigned engines over the pooled engines. While every railroad has its portion of indifferent engineers, the pooled engine will occasionally, even now, get the care of the interested engineer. It is a well-known fact that the same volume of business can be handled with less number of pooled engines than assigned engines, which should result in a corresponding lower total fuel consumption.

*Running of Light Power.*—Minimizing the running of light power is important to fuel consumption. During periods when the run of business is the heaviest in one direction, double heading power to be returned is believed to be the preferable method, as with two engines on a train the possibility of delays due to failure of power is reduced to a minimum.

*Sidings.*—Sidings of sufficient length to hold the maximum train handled, and not too far distant from one another, in which trains can be placed when necessary through failure of power or on account of hot bearings, necessity for re-brassing cars, etc., and into which crippled cars may be thrown and cars placed when necessary to cut down tonnage or to double a grade, etc., are important to prevent delays either to the train in trouble or to following trains, with accompanying fuel economy.

*Conclusions.*—Improvement is always possible and the measure of credit due to the operating department for low fuel consumption per ton mile lies in the progressiveness, strenuousness and the persevering continuity of its efforts to bring about perfect operating conditions and despatching methods in its territory. With railroads hampered, as they are today, by restrictive laws and rate-making legislatures and commissions, the recognized successful railroad men are those who can increase the company's net income by limiting the amount of its financial outgo, and in so far as the efforts of the operating department are successful in bringing about conditions that cut down the fuel consumption per ton mile, it need have no fear of not receiving the full credit thereof.

The report is signed by: M. J. Howley, chairman, T. B. Bowen, J. C. Petty, J. W. Nutting, G. H. Travis and P. J. Miller.

#### DISCUSSION.

The discussion indicated that the operating department was in an excellent position to greatly aid in the reduction of the consumption of fuel. This applies not only to the tonnage of trains as allotted by the train and yard masters, but to the handling of the train by the despatcher both on the road and at the terminals, the specific cases mentioned being, in not calling for power too

soon before the time it is actually needed, prompt delivery of train orders at the stations, more rapid and longer movement of trains, prompt removal of slow orders and the handling of dead-head equipment on through trains instead of on locals. In regard to the tonnage it is as necessary to have enough as not to have too much in order to obtain the best results from the power, and in stormy weather care should be taken not to overload the engine.

An engine can waste a lot of coal at the terminal by being ordered out too soon. Two hours was mentioned as the proper time to be given to the roundhouse for an engine. Considerable fuel is also wasted in delays along the line due to poor despatching. At one of the large terminals in the Middle West it was found that fuel equal to 81 per cent. of that used while the engine was on the road was being consumed at the terminal. By increasing the mileage of the engines between fire cleanings, through more scientific firing, this percentage has been materially decreased. It was found that this could be done very easily with superheater engines.

The operating department often requires that the trains get out of the terminal as rapidly as possible, which sometimes means working the engine very hard for the first mile or so. This tears up the fire to such an extent as to invite engine failure further along the line. That consideration should be given in this respect seemed to be the opinion of all the members present.

Every means should be taken to prevent the stopping of heavy trains on ascending grades or curves; water columns, side tracks, switches, etc., should be so located that trains may be handled to the best possible advantage. Signal lights and markers should be kept in good condition and properly focused so as to prevent unnecessary slow downs.

In supplying engines on short orders it has been found that a cold engine could be made ready quicker by drawing off the cold water and filling the boiler with water at about 210 or 220 deg. In this way an engine can be made ready for service in one and one-half hours.

Above all things, it is necessary to have the proper co-operation between the operating and mechanical departments, and the operating department should solicit suggestions as to how it may aid in fuel economy. It is also necessary for the mechanical department to be thoroughly informed on all conditions and have the absolute facts before suggesting any changes in train handling. On some roads letters have been issued to the various departments asking for suggestions as to how the general service may be improved, which gives one department a chance of showing wherein it may be assisted by another department. Frequent meetings of the road foremen of engines with the despatchers, train and yard masters were suggested as a means of solving many of the seeming inconsistencies.

#### HANDLING SUPERHEATER LOCOMOTIVES.

The committee presented a brief history of the development of the superheater on locomotives and illustrated the various types of superheaters of the high degree type. It pointed out as the principal advantages derived from the use of superheated steam: The increased volume of steam delivered per unit of water evaporated; the prevention of cylinder condensation, and a much smarter engine. When it is realized that the heat losses in the cylinders of a saturated steam locomotive average easily 30 per cent., due to cylinder condensation, which is eliminated with highly superheated steam, and in addition the increase in volume, it is an easy matter to see why the superheater locomotive produces such remarkable results in the way of efficiency and economy.

Add to this the fact that the efficiency of the superheater locomotive increases as the load increases, while it is the reverse with the saturated steam engine, and we have the reason for its being generally adopted by the railroads.

One of the most important features to be considered is the firing question. Inasmuch as the efficiency of the locomotive increases as the degree of superheat increases, it can readily be seen that the flame temperature in the fire-box is a very impor-

tant factor and it is quite necessary that the draft appliances be so constructed as to produce an even, steady pull over the entire grate, and a draft condition that will make the locomotive a free steamer. In order to obtain this, it is generally necessary to use a somewhat smaller nozzle, draft-pipe and stack arrangement.

On account of the smaller volume of exhaust steam and its higher velocity, a moderate reduction in the size of the exhaust nozzle does not produce the same bad effect as with saturated steam, and its reduction to produce the desired draft conditions may be reached before there is any noticeable effect in the way of back pressure. However, the necessity for these changes depends much upon the quality of fuel used and the operating conditions.

The kind of coal to be used has to be considered. For illustration: A superheater locomotive will give less trouble and will be more efficient using Colorado or New Mexico coal than it will with Iowa or Arkansas coal; this is on account of the former coals being almost free from clinker and slag forming properties, while the latter is very bad to clinker the grates and honeycomb the tubes, superheater units and flues. Any stoppage of the flues reduces the boiler heating surface and in case of the superheater flues also reduces the degree of superheat.

Another important feature to be considered is the valve and cylinder lubrication. Owing to the fact that there is no moisture in superheated steam to assist in lubricating, it is generally necessary to use a little more oil than with saturated steam. Enginemen must know that the oil feed to valves and cylinders is constant.

Owing to the high temperature of the valve and cylinder walls when shutting off, and particularly at high speeds, it is necessary to admit a small amount of steam when drifting, in order to prevent the oil from carbonizing and also to prevent drawing in hot gases from the smoke-box. It is necessary to keep the steam pressure in the cylinders above the atmospheric pressure so that air will not get into the cylinders and cause the oil to burn.

It has been learned from experience that a great many of the troubles formerly attributed to insufficient or defective lubrication have been eliminated by the proper delivery of the oil, and the use of metal in valve chambers and cylinders most suitable to high temperature, and more care in fitting up the parts coming in contact with the superheated steam.

The committee also included many valuable instructions as to the handling and operating of superheater engines. The report is signed by J. W. Hardy, chairman, Sheridan Bisbee, W. A. Buckbee, B. J. Feeny and J. W. Heath.

#### DISCUSSION.

By far the most important point brought out in the very thorough discussion of this paper was the absolute need of proper instruction to the men handling superheater engines. This applies not only to the engine crew but to the roundhouse forces as well. To obtain a proper return from the investment made in a locomotive superheater, it must be properly maintained and kept in good condition. The flues must be kept clean, and the flue cleaner not only instructed how to properly clean them, but watched to see that he does not neglect his work, for with the plugged superheater flues the superheater is worse than useless as it deprives the boiler of sufficient heating surface to operate it even as a saturated steam engine. It also greatly increases the cost of maintenance, for with these flues plugged up it is extremely difficult work to remove the superheater units. Some roads do not experience this difficulty as much as others, which is attributed to the kind of coal used and to the use of the brick arch. The Central of Georgia, with the arch and combustion chamber, claims not to experience any trouble in this respect, finding it necessary to clean the flues only once or twice a month.

The question of full throttle and short cut-off received consideration, and the general belief was that when operating above  $\frac{1}{4}$  stroke the throttle should be kept wide open and below that point the speed should be regulated by the throttle. In this respect one member claimed a saving of 5 per cent. in fuel by

the use of the screw reversing gear, special tests being made to determine its value. This is explained by the fact that the engineer finds it easier to more carefully regulate the cut-off of his engine, thereby using considerably less steam. It was stated that many engines carry too much water in the boiler which allows it to be carried over into the superheater, thereby greatly reducing the beneficial effects of the superheater. A height of from  $\frac{1}{2}$  to  $\frac{3}{8}$  of the glass was recommended on level track. Many believed that the relief valve on a superheater engine was a detriment, as it draws air into the cylinder while drifting, causing the oil in the cylinders to carbonize; and, to prevent the smoke and cinders from being drawn back through the exhaust ports, it was recommended that the throttle be left slightly open until the engine came almost to a stop.

#### ADVANTAGES OF THE BRICK ARCH.

By LE GRAND PARISE.

The general introduction of the brick arch in the past few years has been brought about by the necessity for increased boiler power and sustained steam pressure. The other incidental advantages, which, in themselves, are large, are subordinate to the necessity for increased power per pound of metal.

Important improvements are being made in the form and application of brick arches and arch tubes, as is evidenced by the recent combination of the sectional arch on tubes and the Gaines furnace. These improvements are the inventions of men in railroad service who are trying to improve the steaming capacity of the boiler. The long fire-box with a suitable combustion chamber, shorter flues in some cases, improved front ends, improved grates and better air admission in the ash-pan have given surprising results. Important improvements in exhaust nozzles and exhaust passages in the saddle have also been developed in the past few years.

One result of the application of arches is to reveal weaknesses in other factors affecting combustion. It is frequently necessary to give immediate attention to the admission of air through the grates. This is usually done by cutting down the nozzle, whereas the fault lies in the ash-pan. The fire must have air, and when it is considered that it is necessary at times to use 25 tons of free air per hour (or a volume equal to 350 box cars of air), we better appreciate the problem which confronts us when this has to be drawn in by the exhaust nozzle. The more difficulty experienced in getting air into the ash-pan, the more back pressure we produce in the cylinders. The speed of the gases entering the flues is approximately 180 m. p. h. on a locomotive with 70 sq. ft. of grate and  $8\frac{1}{2}$  sq. ft. of flue opening, such as is found on our large Mikados. This will give a fair idea of the difficulty in burning the gases before they escape. The arch, acting as a baffle wall, retards the gas only to a limited extent, but long enough, however, to give a better mixture of the air and gas and greatly improve the combustion.

The fact that the value of the fire-box heating surface is seven times the value of the same amount of flue heating surface was brought out in the Jacobs-Shupert fire-box tests at Coatesville, Pa., conducted by Dr. W. F. M. Goss. The long box equipped with a sectional arch, or with the Gaines combustion chamber, insures the proper distribution of heat over the fire-box sheets. The longer fire-box is a protection to the flues to just the extent that the combustion is more complete. The cold air from the door has a longer travel, and, naturally, absorbs more heat.

Another important matter which must receive constant attention is the care of the arch tubes. No trouble whatever is experienced from scale when a mechanical cleaner is used to cut it out of the tubes at each boiler washout. This practice is now quite general and should be universal. The flow of the water through the tube is reduced very rapidly as the scale increases, due to the rough surface of the interior of the tube.

The value of the arch tube as the means of better water circulation has not received the attention it deserves. In this respect today its value is of decided importance. The problem in good steaming is to utilize the full value of the heating surface. Flues

which lie below the center line of the boiler have difficulty in getting rid of the heat. The only way that this may be accomplished is by getting a more rapid circulation of water in the bottom of the boiler. This will be better understood when it is known that, when the boiler is working up to its capacity, four 3-in. arch tubes will circulate fully 30,000 gallons of water per hour, when the discharge end of the arch tube is designed to discharge at the surface of the water. The boiler of a consolidation engine of modern type ordinarily contains about 3,500 gallons of water. From this it will be seen that the circulation is very rapid.

The 3-in. arch tube ( $2\frac{3}{8}$ -in. internal diameter) in common use today is the minimum size that should be used, as the diameter of the tube has a direct relation to the amount of water circulated. It is quite possible that the future will see the use of circulating tubes of greater diameter than 3 in. A proper design should give all the additional benefits to steaming that are obtained in water tube boilers of the stationary type.

More rapid circulation of water on the heated surfaces will increase the evaporation on account of the rapid replacement of the hot water with colder water. The scouring effect of the water will take up and carry away the heat, allowing the colder water to come into contact with the heated surfaces. It will be necessary to give attention to this feature if we expect to secure the benefit from a higher velocity of gases over the heated surfaces. Heat will flow rapidly through a sheet when there is cold water on one side, and will flow less and less rapidly as the temperature of the water increases. This may be illustrated by the trouble which was experienced with bottom combustion chamber sheets before arch tubes were applied. The over-heating of the sheets was due to the fact that there was no circulation to take away the heat.

Improved steaming means better fire-boxes, and this means more satisfactory operation. The relation between the air supply, the coal and the arch is so intimate that they must be considered together. Free access of air into the ash-pan is very important. The cases are rare where too much air is admitted through the grates when they are properly covered. The important improvements in the future must come from improvements in nozzles or draft; improvements in grates and air supply; improvements in water circulation, and, last but not least, the development of longer combustion chambers.

Anything mechanical that will aid in making a better mixture of the gas and air will improve combustion. The long combustion chamber increases the distance the gas has to travel on its rapid race to the flues, and gives more time for the gas and air to unite in the proper mixture and complete the series of gas reactions, or explosions, before they reach the flue-sheet.

Improvements in the locomotive have been made so rapidly that it is difficult to realize the importance of keeping up with the development. More expert supervision is necessary in order that proper results may be obtained, and the burden of this expert supervision rests upon the members of this Association. The rapid development has brought about the necessity for more expert supervision, and the staff of the manufacturers is being drawn from the ranks of railway service and is made up almost wholly of men who specialize in the work for which their railroad experience has fitted them.

The arch does not admit of using an excessively heavy fire; therefore, the fireman does not have to be instructed on this important factor. The value of the brick arch as a smoke preventive is well known. The cost of the arch is overshadowed by the fuel saving, and the maintenance cost can be kept very low with proper supervision and by having sufficient material on hand at all times to make the necessary and proper renewals promptly.

#### DISCUSSION.

While there was considerable discussion it was generally agreed that the brick arch decidedly improved the economical operation of a locomotive and many predicted its ultimate use on all locomotives. D. R. MacBain stated that all the loco-

motives on the Lake Shore & Michigan Southern are equipped with the arch. As regards the maintenance, the keeping of the arch tubes clean seemed the most important feature. A mechanical cleaner should be used and the cleaning carefully done to prevent any chance of these tubes becoming clogged with scale, thereby not only eliminating chances of failure but insuring good circulation. The advantages obtained by the circulation through the arch tubes were generally accepted as presented in the paper. F. F. Gaines stated that the Central of Georgia was using an arch tube 0.15 in. thick in order to increase this circulation.

Opinions varied as to whether the arch should be placed directly against the tube sheet or some 4 or 6 in. back, good results having been obtained in both cases. The chief objection to the first location is that the bottom flues are liable to become clogged, or, when the opening at the base of the arch is too large, that the front of the fire will be hard to maintain properly due to excessive draft. When the engine is drafted properly, however, it was stated that neither of these difficulties would be experienced.

Mr. Gaines stated that he had found that on engines equipped with a brick arch and superheater much better results could be obtained by setting the exhaust nozzle much lower than has heretofore been the general practice. The long jet of exhaust steam will pull out a greater amount of the smoke and gases, thereby increasing the draft.

Mr. MacBain corroborated this statement, stating further that the exhaust jet of itself should not entirely fill the stack. There should be plenty of space left so that the gases entrained along the jet could readily escape. By a careful study of this problem the steam failures would be materially reduced. He strongly objected to the use of the petticoat pipe, recommending in its stead that pains be taken that the exhaust pass up through the center of the stack. The oblong nozzle was mentioned as giving the best results. The benefits attributed to the use of the brick arch were the saving in fuel by more complete combustion and for the same reason more smokeless engines and the protection of the flues against sudden cold drafts from either the open door or holes in the fire.

#### BLACK SMOKE ON LOCOMOTIVES.

By MARTIN WHELAN.

The problem of smoke elimination on bituminous coal burning locomotives has become a serious one for the railroads, especially for those having extensive terminals in large cities. It is well known to all of you that there is a strong demand and continuous agitation to force the railroads to electrify all such terminals, and the only argument used is the elimination of smoke and cinders from steam locomotives. In large industrial centers the locomotives are responsible for but a small percentage of the total smoke if the railroads make an effort to eliminate it, and the electrification of the railroads in such centers would have comparatively small effect on the general smoke conditions unless the industrial plants were electrified also.

Smoke escaping from a locomotive stack is a waste and the greater the volume of smoke the greater the loss. The emission of black smoke is a sure indication of imperfect combustion. That this can be eliminated has been proved by many observations.

The most effective device for the reduction of smoke is a number of combustion tubes used in conjunction with steam jets. These tubes are located in the side-sheets or back-head of a boiler. The number in the side-sheets usually varies from 4 to 7 on each side. They are 2 in. in diameter and are applied by removing the fifth or sixth stay-bolt above the mud-ring and in enlarging the hole to fit the 2-in. tube. Where the tubes are located in the back-head they are usually placed above the fire-door. The object is to admit air above the fire and to mix it with the gases as they escape from the burning coal. The steam jets are connected by a  $\frac{1}{2}$ -in. pipe with a  $\frac{3}{8}$ -in. nipple entering the tube. Some roads have the nipple opening just flush with the outside sheet and others go to the other extreme

and extend it in almost to the inside sheet. The reason for this difference is that when placed outside the noise is very annoying and it requires constant watching to get the engine crews to use them. The noise is greatly reduced when they are extended inside. The tubes located in the back-head are also very effective, but the noise is very objectionable.

The next requirement is the blower connection with a 1¼-in. pipe extending from the fountain to the smoke-box. The multiple blowers are preferable because they are almost noiseless, but objectionable because the small openings soon become filled with dirt. The double tip blower is the most serviceable. The blower pipe should have a quick-acting auxiliary valve located so that the fireman can reach it easily from either the deck or the seat box. The steam jet connection is usually made to the blower pipe, either above or below the auxiliary blower valve, preferably above, so that the steam jets can be controlled independent of the blower, as there are times when the engine is using steam that it is found necessary to use the jet and not use the blower. The valve which controls the steam jet should be located close to the auxiliary blower valve.

The brick arch is a great help in reducing smoke when using steam, but is of little benefit when the engine is shut off, unless the arch is sealed against the flue-sheet as it usually is in switch engines. When this is done it will pocket the smoke and gases and prove a great benefit. There is the objection of cinders and dirt accumulating on top of it. On freight and passenger engines there is an opening left between the flue-sheet and arch, as they are almost continually using steam, and if properly handled by the crew it will make no smoke.

Another device that is frequently brought into discussions on smoke elimination is the mechanical stoker. The only one that I know anything of that is smokeless is an underfeed stoker used on the Pennsylvania and known as the Crawford stoker. I have seen this stoker in all kinds of service and know it is a success as a smoke eliminator.

Co-operation on the part of the engine crew is of the greatest importance. Without it mechanical devices are a failure. The most effective preventer of black smoke is the man behind the scoop. A fireman who has a fair knowledge of the principles of combustion and makes use of that knowledge will make a better showing on smoke elimination than a disinterested one will make with all the known devices or even the best grades of coal. The men on the locomotives are the principal factors and therefore it becomes necessary to interest and educate them. We all recognize that the firemen of today have not the advantages of the regular engine or the regular engineer. That has been taken from them. Arrangements have been made to take care of the pooled engines, but we have failed to arrange for the changed conditions that the pooled engines have forced on the firemen. All progressive railroads maintain apprentice schools for the purpose of educating the mechanics, but how many pay any attention to the education of the firemen? The mechanical apprentice, after serving four years, still continues under the eyes of a foreman, whereas the fireman after three years spent feeding coal into a fire-box is considered competent to assume the responsibility of managing a locomotive on a busy railroad. The apprentice just out of his time may leave the railroad that educated him and never return, whereas the promoted fireman usually remains during his life, and once he becomes an engineer he has no foreman immediately over him in his daily work, but instead becomes a foreman himself.

In the Cleveland district the crews are disciplined for violations where such violations are the results of carelessness. Both engineer and fireman are held equally responsible. For the first offense they are warned, and if they still continue to disregard the instructions they are suspended, usually for ten days. If engines are equipped with the ordinary devices for the prevention of smoke and the engine crews are properly instructed as to their use and the proper method of firing a locomotive, there will be but little cause for complaint on account of objectionable smoke.

#### DISCUSSION.

The members agreed with the author that the most important item in the elimination of smoke was the proper instruction and supervision of the engine crew, special stress being put on the supervision, as it was sometimes found difficult to have the men follow the instructions given them. This is especially true of the old engineers who were taught to fire by the amount of smoke showing at the stack. One member favored the assignment of one supervisor to every 50 or even 25 engine crews. The brick arch was mentioned as greatly reducing the smoke.

One of the chief troubles experienced is the lack of large enough ash-pan opening so that sufficient air to thoroughly consume the gases may be drawn up through the grates. This fault was well illustrated by statements that oftentimes when an engine was working hard it was possible to obtain better combustion by leaving the fire door open.

Some members spoke of the trouble in reducing smoke under different atmospheric conditions, but it was generally acknowledged that with proper instruction followed by careful supervision smoke could be practically eliminated with the various smoke consuming devices that are in use on the locomotives.

As regards the smoke at roundhouses it was claimed that it could be reduced some 75 to 85 per cent. by careful supervision and that the salary of an inspector and instructor would more than be saved by the amount of fuel that is usually wasted.

#### CARE OF LOCOMOTIVE BRAKE EQUIPMENT.

The only care that the locomotive air brake equipment may be said to need on the road, when all its operative parts are in good working condition in starting out on a trip, is to see that the air pump gets sufficient lubrication to keep it from stopping and that it is not run at an excessive speed.

The Federal law requires that not less than 85 per cent. of the cars in a train (engine and tender being counted as two cars) shall have air brakes in use; also that "all power-braked cars in every such train, which are associated with the said 85 per cent., shall have their brakes so used and operated." While this law makes no provision by which, in the event of any failure that prevents use of the train brakes, the train may be moved beyond the point where this occurred, the fact that this would seriously block traffic has prevented objections to moving such a train carefully and under full control of hand brakes to the next side track, but beyond which, we understand, it may not be taken, with liability of prosecution, until repairs or another locomotive again permit of using the air brakes as required.

This necessarily means that engineers must possess a reasonable knowledge as to how to locate and remedy the causes of the ordinary failures to the locomotive brake equipment that may be susceptible of remedy, in order to prevent delays and the possible tying up of their trains. In spite of the earnest efforts of the Air Brake Association in an educational way, the large amount of explanatory literature sent out by the air brake companies, the air brake knowledge disseminated through books and the magazines of the various railroad orders, and the large amount of money spent by the railroads themselves for air brake instructions to their men through instruction cars, rooms, etc., it is seldom that these men are found discussing what to do in cases of air brake failures, or to find them over-familiar with how to proceed in such cases.

On a prominent Eastern road freight train break-in-twos were almost entirely eliminated by the different road foremen getting their engineers together every two weeks at what were known as "break-in-two meetings," at which the break-in-twos of the division, their probable causes and the best methods of handling trains to prevent them were discussed in a friendly spirit.

While a good knowledge of the construction of the air brake equipment and its operation is excellent, a knowledge of what to do in case of trouble with any of its parts is

indispensable; more so today than ever, and the teaching of how to render "first aid" to an ailing equipment should form an important part of all air brake instructions.

The air pump, furnishing, as it does, the power that operates the brakes, is naturally the most vital part of the equipment, as its failure to operate means the tying up of the train if out on the road and it cannot be started up again. Its operation is controlled to some extent by the pump governor, which in turn may be responsible for the erratic action or complete stoppage of the pump, and it is therefore particularly important that the engineer should be familiar with the possible defects that can occur in either of these parts, how the governor defects may act on the pump and the means that can be used to overcome the troubles.

The rest of the paper contained various instructions on the handling and locating of defects in the pump, feed valve, governor, brake valve, etc., of the automatic, the E.T. and New York L.T. equipment, covering in a general way most of the common defects met with on the road. The committee stated that break-downs are due usually to negligence on the part of someone, and that if proper inspections and repairs are made as they should be, the occasion for delays to patch up a break-down on the road will be rare.

The report is signed by: H. A. Flynn, chairman, T. F. Lyons, F. B. Farmer, L. W. Sawyer and C. M. Kidd.

#### DISCUSSION.

The discussion clearly brought out the importance of maintaining the air brake equipment in the best possible condition and in this way eliminating as far as possible any chance of break-down. This can be done by periodic shoppings. On the Erie the air brake inspector makes a thorough inspection of the brake equipment at each boiler washing.

In case of a break-down while on the road the engineer should first advise the despatcher and if liable to block traffic should ask for help and while waiting for assistance should attempt to repair the damage and prevent an engine failure. F. McArdle mentioned many ingenious and valuable kinks in pump repairs showing how many of the break-downs may be temporarily repaired. He strongly advocated giving the engineer all the instruction possible along these lines. On the Erie all such failures are discussed and studied at the periodical meetings of the engineers so that all of the men may profit by the experience of the engineer that had the failure.

Trouble has been experienced by using superheater oil in the air end of the pump by gumming up the ports of the feed valve. One road found it necessary to "lye-out" the pump just twice as often when this high test oil was used. It was claimed that this service was not warm enough to keep this oil sufficiently thin to pass through the ports of the feed valve. The feed valve should be carefully maintained to prevent stuck brakes or slid flat wheels. An engineer with the proper instruction can readily clean the valve in a very few minutes.

All work coming from the repair shop should be carefully inspected before taken out on the road, as it was believed that most of the failures were due to improper workmanship and inspection. In closing Mr. Farmer strongly emphasized the importance of the careful maintenance of the pump and all other air brake appliances.

#### OTHER BUSINESS.

Among other speakers during the convention were F. F. Gaines, superintendent of motive power, Central of Georgia; D. R. MacBain, superintendent of motive power, Lake Shore & Michigan Southern, and E. W. Pratt, assistant superintendent of motive power, Chicago & North Western. Mr. Gaines and Mr. MacBain made instructive remarks in regard to the brick arch, which are included in a discussion of that subject. Mr. Pratt presented a few pertinent remarks on scientific tonnage rating.

This convention was the best attended of any of the Traveling Engineers' Association, 510 members being regis-

tered, which is a trifle over 50 per cent. of the total membership. The total membership reached the 1,000 mark before the convention closed, and the treasurer reported a cash balance of \$4,143.

The subjects suggested by the Subject Committee for the next convention included committee reports on smoke abatement, the efficient locomotive operation, mechanical stokers, and air brakes, with papers on speed recorders, the chemistry of combustion, and tonnage rating. A committee was appointed to confer with the supply organization in regard to erecting a monument to C. B. Conger, one of the originators of the Traveling Engineers' Association and its president for the first five years of its existence. Mr. Conger in the last part of his life being connected with the supply organization, it seemed fitting that both should co-operate in this matter.

The following officers were elected for the ensuing year: F. P. Roesch, president; Robert Collett, first vice-president; J. C. Petty, second vice-president; J. W. Hardy, third vice-president; D. Meadows, treasurer, and W. O. Thompson, secretary. The new executive committee is as follows: W. C. Hayes, H. F. Henson, Martin Whelan, W. E. Preston, W. H. Corbett, J. R. Scott.

Chicago received the highest number of votes for the next place of meeting.

**ARGENTINE-BOLIVIAN RAILWAY CONNECTION.**—An arrangement has been concluded between the Argentine and Bolivian governments for surveying a railroad from La Quiaca to Tupiza. When this line is joined with that being built from Uyuni to Tupiza the Argentine state railways will be connected with all the Bolivian system, and also with the lines to the Pacific coast.

**HOW A RAILROAD COMBATED A PLAGUE.**—On the trans-Manchurian section of Russia's great 5,000 mile trans-Asiatic railroad, the majority of the track workers are Mongolians—hard working, but brutish in their ignorance and lack of all notions of sanitation. While citizens, nominally, of the new republic of China, they are entirely under Russian influence, so, when the Bubonic plague broke out in northern Mongolia a couple of years ago, it soon reached the toilers on the railroad system and began decimating them to such an extent that the operation of the lines was seriously impaired. What was considered still more serious was the fact that the Russian employees themselves were in imminent danger of infection, and, in fact, numbers were attacked with many fatal results. Thoroughly aroused at this, the Russian state administration of railroads decided to adopt heroic measures. Fire is the best known disinfectant for infected areas, so the Russians simply made a big blaze of the most dangerously affected Mongol quarters of Harbin, the chief town in Russian Manchuria. By this procedure, Harbin was efficiently disinfected. The next step was to disinfect the afflicted quarters along the railroad. This was not an easy task, as, in many instances, the Mongol population objected to being burned out. At a number of settlements, however, the Russian sanitary corps experienced no resistance, for the simple reason that all the inhabitants had succumbed to the plague. In such cases the settlements were burned, bodies and all. Sufferers and suspected cases were brought in by railroad to pest houses, especially established, and given the best attention possible by the Russian medical corps. The sufferers were transported in the box cars, which are generally used for the transport of troops and emigrants who are regarded and treated as so much cattle. Even the cars for the transport of gangs of convicted criminals are made more comfortable than those for the troops and emigrants. During the plague some of these box cars were fitted up as temporary pest houses and run on isolated sidings, so that sufferers could be cared for until better accommodations could be secured. After the plague was finally wiped out, the cars were disinfected, not by fire, but by spraying, and were returned to the regular service. During all this time the Mongol authorities did nothing to check the ravages of the plague but left it all to the Russians.—By L. Lodian.

# TRAIN OPERATION SIXTY YEARS AGO.

Interesting Comparisons Between Modern Methods of Train Management and the Efficient and Progressive Ideas of 1852.

The train schedule shown below is a copy of one which was in force on the Western & Atlantic on March 1, 1852. This is from a time-table which was preserved by George W. Adair, one of the old-time conductors, and has been sent to us by Col. J. L. McCollum, superintendent of the Western & Atlantic, now operated by and as a division of the Nashville, Chattanooga & St. Louis. Newspaper notices of old time-tables are common enough, but this table seems especially worthy of preservation because of its age and its fulness of detail. We reprint also the rules for passenger enginemen and conductors and some other extracts from the code of rules which appears in this time-table.

The Western & Atlantic was (and is) owned by the state of Georgia, and in 1852 it was operated by the state. A perusal of the rules shows that the governor of the state gave passes. This time-table was issued by Wm. M. Wadley, general superintendent. Mr. Wadley was father of Geo. Dole Wadley, now of Macon, Ga., who was for many years connected with the Central of Georgia, and who was general manager of that road about twenty years ago. William M. Wadley was a roadmaster in Georgia in 1848; was general superintendent of the Central of Georgia in 1849-51, and became superintendent of the Western & Atlantic in 1852. Soon after that he went back to the Central of Georgia, and subsequently served on a number of other roads; and he was president of the Central of Georgia from 1866 to 1882.

Clauses in these old rules which from one cause or another will be of special interest to railroad men are too numerous to mention. That rule about preferences to be observed in assigning seats at the table may seem to indicate that dining cars were run at that early day, but that was not the fact. Colonel McCollum, who has been in the railroad service in Tennessee, Georgia and Alabama for 47 years, tells us that it was the eating station that this rule referred to. It will be seen that the train in the schedule made a stop of 35 minutes at noon at Calhoun.

Rules 4 and 5 seem to indicate that flagging ahead around curves was a pretty common practice.

Brakemen in those days were "train hands"; but though only "hands" they were required to be courteous and attentive to the comfort of passengers.

Rule 13 for conductors shows that then, as now, the railroads had to bow down before their maker, the government.

The flagging rule is there in all its glory. Evidently, they had their troubles with it, then as now. Whether the flagman had a flag or not; or whether, if he had one, it was red, white, green or yellow, does not appear. At nights he had, presumably, a lantern, but the rule throws no light on the subject. But as, even in this year 1913, we find superintendents differing as to whether a flagman's lantern shall be white and red or simply red, it is, perhaps, not to be wondered at that in those dark ages they took care not to commit themselves on the subject of color. But it is plain that their fuseses were big enough to be readily seen—or at least were intended to be so. What precautions were taken to prevent those beacon fires on the roadbed from warping the rails is not stated.

And the space interval was in use. See rule 18. It would be unsafe to use this rule as a basis for any conclusion as to how well they maintained the interval, but, surely, they meant well. The system cannot be called a block system, for what would be the "block" could hardly be called an entity; it was a floating factor. Theoretically, the minimum space between moving trains was always the same, as was the case with the fish-odor space-interval, at one time said to have been in use on the railways of Southern New England.

The Western & Atlantic tail light evidently was of any color that might be available. A few years later—say 1857—there was in force on the Western (Massachusetts) Railroad a clause which very likely may have been afterward added to the W. & A. rule, warning enginemen that, in the matter of following another train at night, "no excuse will be received as to having been deceived in regard to the distance." Those were the "good old times"—which some well-meaning persons would renew in these days—when the ability and ingenuity of quick-witted men were depended upon to make up for any lack of appliances or facilities.

From the freight conductors' rules we quote only a few. The speed of freight trains between stations seems in all cases to have been less than ten miles an hour. From Atlanta to Bolton, seven miles, the time was 48 minutes, equal to  $8\frac{3}{4}$  miles an hour. Bolton to Marietta, 13 miles, 92 minutes, equals about 8 miles an hour. The freight took two days to traverse the 137 miles between Atlanta and Chattanooga. It left Atlanta northbound at 7 a. m., and reached Adairsville at 5:33 p. m., and then there is a sub-head "Second Day," and the start for Chattanooga is made at 7 the next morning. The station stops vary from 10 to 60 minutes. No. 4 of the freight conductors' rules illustrates the delightful uncertainty of the provisions for changing meeting points which were in vogue on American roads generally about that time. And this was 1852, eight years after Morse had demonstrated the practicability of his telegraph between Washington and Baltimore, and was some months, at least, after Charles Minot made actual use of the telegraph, on the Erie, to make meeting points.

## WESTERN & ATLANTIC RAILROAD. Schedule for Passenger Train—Up.

### PICTURE OF ENGINE AND CARS

Number of station.	Name of station.	Time for arrival.	Time for departure.	Time between stations.	Remarks.
	Atlanta .....	.....	6.00 A.M.	28	
No. 1	Bolton .....	6.28 A.M.	6.33	36	
2	Marietta .....	7.09	7.39	44	
3	Moon's .....	8.23	8.23	16	
3½	Acworth .....	8.39	8.47	17	
4	Allatoona .....	9.04	9.04	28	
5	Cartersville .....	9.32	9.47	15	Pass down frt.
5½	Cass .....	10.02	10.07	20	
6	Kingston .....	10.27	10.32	16	
6½	Hadley's .....	10.48	10.48	24	
7	Adairsville .....	11.12	11.17	27	
7½	.....	11.44	11.45	14	Pass down pass.
8	Calhoun .....	11.59	12.34 P.M.	24	
8½	Resaca .....	12.58 P.M.	1.03	24	
9	Tilton .....	1.27	1.35	35	Pass down frt.
10	Dalton .....	2.10	2.18	26	
11	Tunnel Hill .....	2.44	2.49	26	
11½	Ringgold .....	3.15	3.20	20	
12	Opelika .....	3.40	3.45	22	
13	Chickamauga .....	4.07	4.14	21	Pass up frt.
13½	Chattanooga .....	4.35	4.40	20	
	.....	5.00			

### RULES FOR PASSENGER ENGINEMEN.

1. Each engineman will keep a watch, which must be regulated by the time of his conductor at the commencement of each trip; and he will always have in his possession the current schedule book.

2. No train will leave a station before the time stated in its schedule, or without an order or signal from the conductor. The engineman must always give notice before starting by the sound of his bell or whistle.

3. Should any stock be killed which may be likely to endanger the safety of the next train passing, the engineman will always stop his train until the track is cleared.

4. Passenger trains must not exceed the speed of their schedule under any consideration, except when they are behind time, in which case the speed may be increased three miles per

hour, generally. In passing turnouts, the speed must be diminished to six miles per hour, and on all long high bridges to eight miles per hour.

5. The engineman will permit no person, not duly authorized, to ride upon his engine or tender. He will run uniformly and steadily between stations; delay as little as possible for wood and water, and take care that the wood is so loaded as not to fall from his tender. He will report to his conductor the exact amount of wood taken from each station, and all failures of a supply of wood and water.

6. In connecting and in starting with his train, the engineman will be exceedingly careful in the management of the throttle, so that the cars may not be injured, or the passengers annoyed by the sudden violence of the start.

7. When a train is approaching a stopping place, it is the duty of the engineman to see that the fire is so regulated that it will be unnecessary to blow off steam while the engine remains stationary.

8. Enginemen must not, under any circumstances, intrust their engines to firemen. When an engine is to be moved, it must be done by the engineman in person, unless at Atlanta, where it may be done by any person appointed for that purpose by the superintendent of machinery.

9. All engines running at night, out of time, must keep their dampers open so as to show light.

10. When passing cotton, either on platform, cars or near the warehouses, engines must be made to exhaust as lightly as possible.

11. One short sound of the whistle is a signal for the brakeman to put on the brakes; two sounds of the whistle is the signal to take them off.

12. When an engine is to be followed during the day by any other, the forward one will carry on its buffer a red flag, spread. If no engine is to follow during the day, then the flag must be furled and bound to the staff.

For any violation of the above rules, for running off at turnouts; for killing of stock by daylight; and for all other irregularities, the general superintendent will impose such fines as he deems just, and called for by the nature of the offense.

#### RULES FOR PASSENGER CONDUCTORS.

1. Each conductor will keep a watch, which must be regulated by the timepiece at the depot in Atlanta.

2. The conductor will always have the current schedule book in his possession; and it is his duty to see that his train runs in accordance with its rules, and in case of any violation of them by the engineman or other person connected with the train, he will immediately bring the attention of the party to the rule violated, and have it corrected.

3. No train will run without a cord connecting the rearmost car with the bell of the engine. Trains running in the same direction, which are to pass each other, the rearmost one not arriving in time, the forward one to proceed in regular schedule time.

4. If either of the passenger trains fails to arrive at the passing [meeting] place in time, the other will wait fifteen minutes and then proceed, continuing fifteen minutes behind time until the other train is passed or heard from. Then the speed may be increased three miles per hour. Should both trains be delayed more than fifteen minutes, they will become irregular, and will be governed by Rule 5 for passenger conductors.

5. Should any two trains approaching each other become irregular, great caution is necessary in proceeding: run slowly, and keep a signal man far enough ahead to stop safely in case of meeting.

6. A passenger train running out of time will avoid the regular freight trains, which, in all such cases, will run precisely one hour behind their schedule.

7. The conductor will enter on his report the number of his paying passengers (ministers of the gospel, when on business connected with their profession, to be charged half price), and

the name of every free passenger; and he will be subject to pay the fare of all who may ride free without being duly authorized. No person will be permitted to pass free without a ticket from the governor or general superintendent, except the officers and agents of other roads (a list of whom can be had at the general superintendent's office), and officers and agents of this road, when on business connected with their duties; or workmen on the road, who must be provided with passes from the general superintendent, supervisors or other officers of the repair department. All free passengers and persons connected with the road will give place to paying passengers, and in no case crowd them out of their seats in the cars or at the table.

8. He will carefully note, in his report, the time of arrival and departure of his train from each station; the exact amount of wood taken from each station, which must be noted at the time; and all stock killed that comes to his knowledge, together with any unusual occurrence on the trip. When any detention occurs to the train, the cause of it must be distinctly stated.

9. He will inspect the running gear of his train at every station.

10. He will pay every attention to the comfort and accommodation of his passengers—see that his train hands are courteous and attentive to them, and be held responsible for the safekeeping and proper delivery of their baggage.

11. He will allow no passenger to carry merchandise as baggage without extra charge.

12. He will allow no person to stand upon the platform of the cars when the train is in motion.

13. He will never leave Atlanta or Chattanooga without the mail, without first sending to the post office. It is also made his special duty to see that the mails are delivered and received at the way stations. This may be confided to the train hands, who for neglect of duty, shall be fined; but it shall, nevertheless, be the business of the conductor to see that this duty is performed.

14. As a general rule, when trains meet between stations, the train nearest the turnout will run back. Any dispute as to which train is to retire is to be determined at once by the conductors, without interference on the part of the enginemen. This rule is required to be varied in favor of the heaviest loaded engine, or worst grades, if they meet near the center. In case of backing, a man must be placed on the lookout, so that any danger to the rearmost part of the train may be seen, and the engineman at once receive notice. The backing must also be done very cautiously.

15. Freight or extra trains will always, when necessary, give relief to the passenger trains. If the engine of the passenger train meets with an accident, or cannot perform its duty, the engine of any freight or extra train may be put in requisition for the passenger train by the conductor of the latter.

16. If a train meets with an accident so as to obstruct the road, a man must be stationed at a sufficient distance and in a proper direction to warn approaching trains of danger; and, if at night, fires must be made and kept up through the night, at each end of the train in such manner and place as to be seen by an approaching engine.

17. A train stopping at any station at night, must invariably be run on the turnout, so as to leave the main track clear. In all cases where a train stops at night, a strict watch must be kept.

18. Trains running in the same direction and near each other, will always observe a distance of one mile; and at night the front train must show a light on the rearmost car for the government of the train in its rear.

19. As a general rule, passenger trains will take the turnout when passing freight trains, excepting when freight trains have to wait for the passenger trains, in which case the freight train will take the turnout (if it is long enough) so as not to delay the passenger train. When freight trains have to pass [meet] the one having the most time at the station will take the turnout. It is the special duty of the conductor that arrives





railroads should never settle claims without investigation, even when the claimant gives a bond.

There was also recommended by the sub-committee, through the conference committee, a post card form for the acknowledgment of claims, which form was likewise adopted by the association.

The form of the blank for overcharge claims is shown above, reduced one-half in width and height. This blank is printed on light yellow paper. That for loss and damage is on dark yellow paper. It is similar to that here shown except in the central part, headed "Detailed statement," etc. This paragraph requires certain different particulars.

### A MODEL DAIRY.

The Pennsylvania Railroad has been running, in connection with an agricultural demonstration train, a car fitted up to show modern dairy appliances. The Pennsylvania has a milk department organized to develop the dairy industries along its lines which has done notably good work. This department estimates that milk can be shipped anywhere within a radius of 500 miles from New York or Philadelphia into these cities in good condition and in time to be pasteurized, bottled and delivered to the consumer the following morning. There may not be any wider margin between scientific farming and unscientific farming than between scientific dairying and unscientific dairying, but the chances for utter failure in the dairying field are unquestionably far greater than for the farmer who confines himself entirely to agriculture.

The accompanying photographs show two views of the interior of the Pennsylvania's dairy car. This car contains a model of a silo, a dairy barn in miniature, a concrete stall equipped with stanchion feed car and litter carrier, with continuous water and feed trough, and a complete dairy house with inexpensive equipment for weighing, testing and cooling milk, washing tinware, etc.

INDO-CEYLON RAILWAY.—Work on the Ceylon side of the railway is making rapid progress. The line has been laid right up to Talaimannar, the terminus of the Ceylon line, and ballast trains are about to be run. Two large jetties have been erected at Talaimannar, one for use in the northeast monsoon and the other in the southwest. The south jetty is about 1,000 ft. long, with a breadth of about 40 ft. Three lines run along each jetty, so that trains may be run down either side, and, in addition, there is a gangway several feet in width for the use of passengers. Alongside the end of each jetty a warehouse, 200 ft. long, is to be erected. Customhouses will also be erected on the jetties. It is probable that electric light will be installed at Talaimannar before the opening of the line. The whole work is expected to be completed by the end of the current year.



Feed Trough In Dairy Car.



Interior of Dairy Car.

## General News.

The Western Maryland has arranged with a correspondence school to instruct its firemen in the use of the air brake, and an instruction car will soon be put in service.

A. E. Baer, an engineman of the Louisville & Nashville, has received a reward of \$1,000 from the post office department for having captured a train robber last September. It is said that Baer had already received a reward of \$500 from the railroad company.

The Western Maryland has given a contract for the installation of telephones for train despatching on 326 miles of its lines. With this addition every division but one will be thus equipped; and the company intends eventually to use telephones throughout the whole of its lines.

The four arbitrators chosen by the Eastern railroads and the employees to settle the conductors' and brakemen's wages have selected a fifth in the person of Hon. Seth Low, of New York, president of the National Civic Federation, and have also selected a sixth but, as he has not yet accepted the place, have not given his name. The sixth, when he accepts, will complete the board.

The number of ties laid in the tracks of the New York, New Haven & Hartford during the twelve months ending with the last fiscal year was 1,983,296; and all of those laid in the main tracks of the main line west of New Haven (123,672), were creosoted. Creosoted ties and screw spikes are now used for all renewals in the main line tracks between New Haven and New York.

The Pennsylvania Railroad once more reminds the public that high heels and hobble skirts are responsible for a large proportion of the injuries sustained by women while getting on and off trains. Notes are published of six accidents to women reported within three days from stations on the Pennsylvania; but there is no affidavit as to whether the cause was or was not connected with skirts or heels. Indeed, the tightness of the skirts and the highness of the heels in these particular cases are left wholly to conjecture.

According to a press despatch from San Francisco, Mr. Hangar, the government conciliator, has averted a strike of passenger trainmen of the Southern Pacific, by inducing the company to abandon its plan to make of the electric trainmen a separate class. The men had protested that the segregation of the electric lines terminating at San Francisco Bay from the steam lines would result in reducing their wages, or in preventing them from securing as high wages as are or may be paid to men on steam operated trains.

The state of Pennsylvania has adopted a law, which goes into effect next October, limiting the number of hours which women may remain on duty in certain employments, and requiring that they be allowed forty-five minutes for luncheon in the middle of the day. This law applies to women who act as station agents and telegraph operators; and the state public service commission has received from a representative of the women telegraphers on the Pennsylvania Railroad a petition, asking that the lunch-hour clause of the law be not enforced.

Last week we noted the transportation of 30,805 crates of melons, in a single train, a distance of 111 miles in five hours. This week the enterprising Southwest reports a sensation of another kind: the transportation of 240 crates of peaches by parcel post. This little shipment passed through Albuquerque, N. M., on the night of August 17, where the crates were transferred, on their way to Gallup, N. M. These peaches had been carried in the mail bags (?) about 1,000 miles. From the railroad standpoint the cost of this service is represented by  $x$ , and the receipts by  $a$ .

The Missouri, Kansas & Texas has contracted with Butler Bros., of Dallas, Tex., for the burning of more than one million yards of earth and its converting into ballast, at a cost of approximately \$1,250,000. An additional \$500,000 will be spent by the railroad in distributing the ballast over six hundred miles of its track in Texas. Plans have been adopted for the construction of burning pits at Hillsboro, Granger, Reedville and Rogerville.

In order to burn this enormous quantity of ballast about 250,000 tons of lignite coal will be required. More than 150,000 acres of land have been leased to furnish the surface earth for the burning pits.

Professor Emory R. Johnson, of the University of Pennsylvania, who is United States Commissioner of Panama Canal Traffic and Tolls, has gone to Europe to compare toll rates with the leading bureaus in England and on the Continent. He will confer with the German Bureau of Registry, the Suez Canal Company, the British Board of Trade and Lloyds Registry, and will report the result of his conferences to the Secretary of War. An endeavor will be made to bring about a uniform system of ship measurement throughout the world. Professor Johnson, who has just been appointed a member of the Pennsylvania State Public Service Commission, will return September 27.

Attorney-General Looney of Texas has proposed legislation to require every railroad in Texas to be operated independently and to have no officers in common with any railroad of another state. All the minutes and orders adopted by the boards of directors would be without effect unless approved by the Texas railroad commission and all contracts and agreements would have to receive its approval. The commission might employ auditors and engineers at the expense of the state to examine into the affairs of a railway, and officers and employees of a road who violated the provisions of the act would be subject to criminal prosecution. Texas railroads would be allowed to receive financial assistance from foreign corporations but without impairment of their independence.

J. M. Fitzgerald, president of the Western Maryland, has received from the State of Pennsylvania, a gold medal, commemorating the excellent service rendered by that road on the occasion of the celebration at Gettysburg last month, when, according to the published statement, that road carried to and from Gettysburg about 60,000 passengers. The medal was presented by the governor of the state and the Gettysburg Commission. In their letter to Mr. Fitzgerald, they make mention of the splendid services rendered by the president personally, the promptness of the train movements, and the fact that no accident of the slightest character occurred during the entire period of the celebration. Mr. Fitzgerald was at Gettysburg during most of the celebration, giving personal attention to the management of the trains.

The Farmers' Union of Texas at a recent meeting adopted resolutions regarding train crew legislation. The resolutions set forth that the farmers of Texas produce 85 per cent. of the wealth of the state; that there cannot be profitable production without adequate transportation; and that, therefore, the Farmers' Union believes in encouraging capital to build and operate railroads. The resolutions add that "inasmuch as all the expenses of operating the railroads must be paid by the shippers, and ultimately rest upon the shoulders of the producers, we demand and expect that our railroads shall be economically operated and at the very least expense consistent with safe and adequate service." The union therefore opposes all unjust burdens upon the railways and endorses the action of President Radford and the other officers and members in opposing the full crew bill before the thirty-third legislature. The resolutions add, "The expense of operating railroads is much larger than it should be because of the exorbitant salaries paid to railroad employees and officials and stealage of goods while in transit, and as this unnecessary and preventable expense is borne by the producers we demand that it be eliminated."

The Interstate Commerce Commission has issued an order, dated July 23, providing for a new account, No. 113½, in its classification of railway operating expenses, to provide for "Valuation Expenses." Items in this account will be entered under General Expenses. The aim is to segregate from other operating expenses all extraordinary expenses of a carrier due to its compliance with public requirements as to valuation of its property. This account must not in any degree relieve the other primary accounts of expenses ordinarily chargeable thereto under conditions existing while no valuation work is in progress. The new account should include expenses incident to the ascertainment (in accordance with the Act to Regulate Commerce

as amended March 1, 1913, or with other federal or state requirements) of the value of property owned or used by the accounting carrier, such expenses including pay, and office, traveling, and other expenses of officers specially employed or assigned to such work, and of their assistants, clerks, and attendants, and the cost of stationery and printing, and of engineering supplies consumed. No charge should be made to this account for the salaries of officers or of their clerks and attendants for incidental services in connection with valuation work, but special office, clerical, traveling, and incidental expenses incurred by these officers on account of such work may be included as a part of the cost of the work.

**Tourist-Car Luncheons.**

An eastern exchange rises to remark in favor of the Arcadian simplicity of carrying a lunch when traveling, and eating it in the regular coach, pointing out, what is perfectly true, that this is the best that an average tourist can afford. But something is to be said on the side of the diner, notwithstanding its exaggerated prices and the tips. Let all the passengers on a long journey adopt the pastoral plan and traveling becomes far more of a burden than exorbitant prices can possibly make it. The Gothicism of the average tourist car or day coach crowd at tea is not calculated to enhance the joy of travel. It is a feature that never enters into the advertising matter put out by railroad companies. The expenses in the diner are exorbitant, but some things are even worse.—*Omaha Bee.*

**Pennsylvania Pensions.**

Thirty-one employees of the Pennsylvania Lines east of Pittsburgh were retired under the pension rules on the first of July, and fourteen on the lines west of Pittsburgh; and the press bureau of the road has issued a pamphlet, entitled "The Railroad Roll of Honor," giving the names and titles of these men and the number of years each has served. Three of them have been in the service fifty years or longer, and the pamphlet contains brief sketches of their lives, with portraits. These three are George W. Blair, foreman, and Samuel Alloway, clerk, Philadelphia, and John Manning, engineman, New York. A pension roll, like a pay roll, serves as a reminder that railroad work is not all done by men who wear uniforms or who are constantly before the public. In this list we find laborers, clerks, carpenters and track watchmen; a blacksmith, a sweeper, a boiler-maker, a trucker, a watchman, a gateman, a tallyman, a cooper, and car builders and machinists.

**A Meeting-Point Rule.**

A correspondent in Pennsylvania, commenting on the question of making safe train movements at meeting points under the space interval system, as discussed in our issue of August 1, sends a copy of the rule in force on his road, which is given below. He admits, however, that this rule, though satisfactory to the officers of the road, as regards safety, is not always expeditious. But most of his stations, he says, have signals fixed at the clearance points, making these special provisions unnecessary. The rule follows:

"A train may pass a stop signal to go on a siding subject to the following conditions. When the block signal controlling the opposing train is not located at the clearance to the siding and the block is not occupied by an opposing train, a train may pass the stop signal, after ascertaining the condition of the block and securing permission from the signalman. When such movements are made the signalman must not give clear block for an opposing train until the train is on the siding clear of the main track. If the block is occupied by an opposing train, the train will be governed by Rule 99, and must not pass the stop signal until the opposing train arrives and is stopped at the clearance to the siding.

"When the block signal governing the opposing train is located at clearance to the siding, a train may pass the stop signal, to enter the siding, before the opposing train arrives."

Under this rule and the practice under it, after No. 10 had entered block at "A," Extra 72 south would be held at "W" until No. 10 had arrived and was stopped by the meet order and flag as clearance to siding (c), Extra 72 then pulling into siding. If No. 10 had not entered at "A," Extra 72 would be permitted to

pull in, after conferring with signalman, No. 10 being held at "A" until the extra was clear.

**More Extensive Governmental Sanitary Inspection.**

The treasury department has issued orders to the inspectors of the supervising architect's office to report to the department unsanitary conditions found by them in their journeys on interstate railroad trains and at stations at which the inspectors arrive or depart. This is an extension of the supervisory activities of the treasury department announced last autumn (*Railway Age Gazette*, pages 807, 823) when the commissioned officers of the Public Health and Marine Hospital service were ordered to make these inspections, in the interest of the health of passengers making interstate journeys. Since the order to the health officers was issued the treasury department has forbidden common drinking cups on cars, etc. The secretary of the treasury has authority over the public health department, and also over the architects who design most or all of the federal buildings of the country. These public building inspectors have to pass upon the cleanliness, sanitation and maintenance of the buildings; so that they are, presumably, well qualified for this new service.

Mr. Allen, assistant secretary of the treasury, says that the inspections which have been made by the officers of the public health service have been highly successful, the railroads co-operating cheerfully; and this satisfactory result appears to have been the reason which actuated the department in setting more men at work in the same line.

The reports now called for are to be sent to the Public Health Service department. Inspecting officers of the architect's office have been cautioned to go about their task with the greatest care and tact and not to suggest nor attempt any changes in sanitary apparatus or methods. If changes or reforms are needed or desired the matter will be left entirely to the public health department.

**Twenty-Pound Parcels by Mail.**

In accordance with announcements made last month the post office department now accepts packages for transmission short distances by parcel post up to and including 20 lbs. Under the new rule the rate on parcels exceeding 4 oz. in weight will be five cents for the first pound and one cent for each additional 2 lbs. or fraction thereof when intended for local delivery, and five cents for the first pound and one cent for each additional pound or fraction thereof when intended for delivery at other offices within the first and second zones. Section 1, 3, 7 and 15 of the parcel post regulations are amended accordingly. The pound rates of postage in the first and second zones under the new rule will be as follows:

Lbs.	First zone		Second zone rate.	Lbs.	First zone		Second zone rate.
	Local rate.	Zone rate.			Local rate.	Zone rate.	
1...	\$0.05	\$0.05	\$0.05	11...	\$0.10	\$0.15	\$0.15
2...	.06	.06	.06	12...	.11	.16	.16
3...	.06	.07	.07	13...	.11	.17	.17
4...	.07	.08	.08	14...	.12	.18	.18
5...	.07	.09	.09	15...	.12	.19	.19
6...	.08	.10	.10	16...	.13	.20	.20
7...	.08	.11	.11	17...	.13	.21	.21
8...	.09	.12	.12	18...	.14	.22	.22
9...	.09	.13	.13	19...	.14	.23	.23
10...	.10	.14	.14	20...	.15	.24	.24

Fresh meats and other perishable articles will be accepted for mailing to offices within the first and second zones.

Ralph Peters, chairman of the Committee on Railway Mail Pay, has issued a statement explaining the attitude of the railroads as follows:

"The railroads have already carried the greatly increased burden of the parcel post from January 1, when it was instituted, to July 1, without one cent of additional payment.

"Whatever may be the views of the public as to railroad capitalization, and altogether aside from the question of railway mail pay in general (which the railways maintain is inadequate), it surely cannot be the purpose of the American people to force the railroads to carry this new mail matter without payment.

"The railroads will carry the parcel post, even with the 20-lb. limit. Any other course on their part would impose such a serious inconvenience upon the general public as to be unthinkable.

"But the railroad companies of the United States wish it to

be known by the people that this service is exacted of them by the government without making provision for compensation."

**Suggestions for Traffic Efficiency.**

When information is requested by a shipper or consignee do not refer him to someone else but if possible secure the information he wants, from the proper source, and give to him. When asked to perform some service, or secure certain information or correct an error, the shipper should be made to feel that we are interested in his request. Do what can be properly done in the matter and as soon as result can be accomplished or information obtained, let him know.

Do not make promises unless they can be fulfilled. When conditional promises are made and cannot be kept confer at once with the person interested and tell him frankly, explaining reason; this will gain the confidence of patrons and make friends by the interest shown and the efforts made.

In case a shipment is going to a station, the name of which might be easily confused with other stations, great care should be exercised. The forwarding of freight to improper destination results in claims which often result in loss of future business for the same consignee or his friends. The good will of a shipper or consignee will be communicated to his business associates or personal friends.—*W. S. Andrews, Queen & Crescent.*

**Railway Results in 1912 Compared with 1902.**

J. F. Holden, vice-president of the Kansas City Southern, has prepared and made public a comparison between the results of railway operation in the United States in 1902 and 1912, which he has based on the "Statistics of Railways in the United States" of the Interstate Commerce Commission for 1902, and the abstract of the commission's statistics for the year ending June 30, 1912, which was issued by the commission on July 1, 1913. The increases in the various figures and Mr. Holden's comments on them are given below:

Total trackage, in miles.....	Increase	86,519	or	31	per cent.
Number of locomotives ....	"	20,025	or	48	per cent.
Number of freight cars.....	"	657,027	or	42	per cent.
Number of passenger cars....	"	13,619	or	37	per cent.
Number of employees.....	"	509,903	or	43	per cent.
Wages paid to employees....	"	\$567,085,580	or	87	per cent.
Passengers carried one mile..	"	13,345,058,186	or	68	per cent.
Freight tons carried one mile	"	105,666,235,070	or	68	per cent.
Total revenue .....	"	\$1,100,537,700	or	63	per cent.
Total operating expenses....	"	\$842,714,684	or	76	per cent.
Net revenue .....	"	\$257,823,016	or	42	per cent.
Taxes .....	"	\$58,657,072	or	107	per cent.
Net operating income.....	"	\$199,165,944	or	35	per cent.
Dividends paid .....	"	\$60,950,772	or	33	per cent.
Operating ratio to revenue..	1902			64.66	per cent.
Operating ratio to revenue..	1912			69.30	per cent.
Par value of outstanding stock on which no dividends were paid in 1912..		\$2,909,693,873	or	34	per cent. of total
Par value of outstanding bonds on which interest was not paid in 1912.....		\$808,464,701	or	7½	per cent. of total
<b>Total .....</b>		<b>\$3,718,158,574</b>			
To have paid 5 per cent. on this amount the railroads should have earned an additional net revenue of....		\$185,907,928			

Had the net revenue for the twelve months ending June 30, 1912, after deducting taxes, increased in the same proportion as the gross earnings, viz., 63 per cent. instead of 35 per cent., there would have been added to the net earnings approximately \$155,000,000; but not sufficient by \$30,000,000 to pay 5 per cent. on the stocks and bonds on which no interest or dividends were paid.

"With this kind of showing it is not surprising that the investing world has lost confidence in railroad securities, and railroad managers are at their wits' end to know how to secure additional revenue to meet the needs of increasing transportation demands.

"It is not to be supposed that the commerce of the country will stand at its present proportions; in fact, there is no reason why it should not increase in the next ten years the same as in the past ten years, but it will be seriously handicapped if the railroads cannot secure the needed money to take care of the increasing growth."

**Rescue of Passengers from a Flood.**

Readers of the *Railway Age Gazette* may recall a news item in the issue of July 18 to the effect that a train of the Pennsylvania line had been surrounded by a flood, near Marietta, Ohio, so quickly that the passengers had to be rescued by boats. The company has issued a leaflet describing this unusual emergency, and containing portraits of freight conductor W. H. Sweeney and passenger conductor W. S. Davis, to whom the road has presented gold watches in recognition of their prompt and intelligent action. The circular says in part:

The Muskingum, Wills Creek and Duck Creek Valleys were visited Sunday evening, July 13, with an almost unprecedented rain and electrical storm which continued unabated throughout the night. Duck Creek rose to a stage 6 ft. higher than ever before. It is not unusual, after a heavy rain, for it to overflow its banks a few feet, and for trains to run slowly through it so long as the water is not high enough to extinguish the fire in the locomotive. Freight train 630 was stopped by small driftwood on the track. While the crew was working to remove this, the rapidly rising water extinguished the fire in the engine. The train was later entirely submerged, the caboose broke away from the rest of the train and was pushed by the stream three-quarters of a mile without leaving the rails.

Following the freight was passenger train No. 600, which was held at Stanleyville by the flagman of the freight. On learning of the difficulties ahead, the passenger train crew decided to back their train south to get on higher ground, but fearing that they might have trouble, they threw some stove wood on the engine for emergency use. The train was soon stopped to move a small tree which had lodged on the track, but while the crew were endeavoring to remove this, the stream was rising more rapidly all the time, lodging and depositing driftwood between the trucks of cars.

So much time was consumed in attempting to remove this debris that the fire in the passenger engine was drowned, as was the fire in the engine of yet another train following, which in the meantime had left its cars and had come to the assistance of No. 600.

While part of the crew continued their efforts to clear away the driftwood, Conductor Davis and Fireman Alloway went to a farm house to telephone to Marietta for assistance. They were taken from the train to the nearest land in a small flat boat, owned by a young farmer boy named Ralph Farley. In the meantime Conductor Sweeney, of the freight had started for assistance, and joined Davis.

As the four men were returning to the passenger train to rescue the passengers, the little boat struck a post under the water and turned turtle. . . . Sweeney, after thrilling experiences, recovered the boat and with an old hat was able to bail nearly all of the water out and go to the assistance of the passengers.

All of the men and one woman on the train had in the meantime been assisted to the roofs of the passenger cars. The other women passengers were taken through the coach windows before the water reached the seats. All of the women were taken to the shore on the east side of the train before any of the men were rescued.

There were no oarlocks on the small boat and they had much difficulty in paddling through the swift currents. To make better progress and eliminate another possibility of accident, a heavy wire—supplied by a telephone lineman who happened to be a passenger on the train—was stretched taut above the water, tied to a tree on shore and at the other end fastened through two windows of a car of the train. The crew used this wire to tow the boat back and forth between the cars to the east side. All of this was accomplished without any apparent anxiety or excitement on the part of the passengers.

The train crew saved all of the mail which was on the passenger train, some of the express matter, and all of the baggage except three trunks.

Not long after the passengers had been removed from the train and the water had about reached the tops of the cars, the old covered bridge which spanned Duck Creek at Stanleyville left its foundations and floated broadside toward the front end of the passenger engine, but the bridge struck a tree with sufficient force to veer it away. It just touched and broke off the headlight of the engine.

A check for \$25 was sent to Ralph Farley, George Trautner

and Herman Trautner, farmers who rendered valuable and timely assistance.

#### Master Blacksmiths' Convention.

The twenty-first annual convention of the International Railroad Master Blacksmiths' Association was held at the Hotel Jefferson, Richmond, Va., August 19-22. President McSweeney called the meeting to order at 10:20 a. m. August 19, after which George W. Kelly led in prayer. W. W. McLellan, in a brief speech, introduced Gov. Mann of Virginia, who welcomed the association to the state. He was followed by Mayor Ainslie, of Richmond, who gave the members the freedom of the city. Addresses of welcome were also made by the president of the Richmond Chamber of Commerce, by W. D. Duke, assistant to president, Richmond, Fredericksburg & Potomac on behalf of the railroads, and by the Rev. J. T. O'Farrell. An account of the proceedings of the convention will be published in next week's issue.

Among the manufacturers of railroad supplies who exhibited at the convention were the following:

- Ajax Manufacturing Company, Cleveland, Ohio.—Forgings made on Ajax machines. Represented by J. B. Blakeslee, A. L. Guilford, Henry Gaul and J. A. Murray.
- Chambersburg Engineering Company, Chambersburg, Pa.—Power-driven hammers. Represented by G. Nixon.
- Clement Rostein Company, Philadelphia, Pa.—Steam hammer packing. Represented by Norman Miller.
- E. F. Houghton & Company, Philadelphia, Pa.—Quenching and hardening oils. Represented by E. Niessen.
- National Machinery Company, Tiffin, Ohio.—Forging and heading machines. Represented by E. R. Frost.

#### American Association of Railroad Superintendents.

The annual convention of the American Association of Railroad Superintendents, was held at Hotel Sherman, Chicago, August 21 and 22. Those eligible to membership in this association are general superintendents, superintendents, assistant superintendents, trainmasters and assistant trainmasters of railways doing a freight or passenger business. The dues are \$2 yearly, which should be remitted to E. H. Harman, secretary, Union Station, St. Louis. A report of the meeting of the association will be published in the *Railway Age Gazette* next week.

#### MEETINGS AND CONVENTIONS.

*The following list gives names of secretaries, dates of next or regular meetings, and places of meeting.*

- AIR BRAKE ASSOCIATION.—F. M. Nellis, 53 State St., Boston, Mass.
- AMERICAN ASSOCIATION OF DEMURRAGE OFFICERS.—A. G. Thomson, Boston, Mass. Convention, May 19, 1914, St. Louis.
- AMERICAN ASSOCIATION OF GENERAL PASSENGER AND TICKET AGENTS.—W. C. Hope, New York. Annual meeting, October 14-15, Philadelphia, Pa.
- AMERICAN ASSOCIATION OF FREIGHT AGENTS.—R. O. Wells, East St. Louis, Ill.
- AMERICAN ASSOCIATION OF RAILROAD SUPERINTENDENTS.—E. H. Harman, St. Louis, Mo.; 3d Friday of March and September.
- AMERICAN ELECTRIC RAILWAY ASSOCIATION.—H. C. Donecker, 29 W. 39th St., New York.
- AMERICAN ELECTRIC RAILWAY MANUFACTURERS' ASSOC.—H. G. McConaughy, 165 Broadway, New York. Meetings with Am. Elec. Ry. Assoc.
- AMERICAN RAILWAY ASSOCIATION.—W. F. Allen, 75 Church St., New York. Next meeting, November 19, 1913, Chicago.
- AMERICAN RAILWAY BRIDGE AND BUILDING ASSOCIATION.—C. A. Lichty, C. & N. W., Chicago. Convention, October 21-24, 1913, Montreal.
- AMERICAN RAILWAY ENGINEERING ASSOCIATION.—E. H. Fritch, 900 S. Michigan Ave., Chicago.
- AMERICAN RAILWAY MASTER MECHANICS' ASSOCIATION.—J. W. Taylor, Old Colony building, Chicago.
- AMERICAN RAILWAY TOOL FOREMEN'S ASSOCIATION.—A. R. Davis, Central of Georgia, Macon, Ga.
- AMERICAN SOCIETY FOR TESTING MATERIALS.—Prof. E. Marburg, University of Pennsylvania, Philadelphia, Pa.
- AMERICAN SOCIETY OF CIVIL ENGINEERS.—C. W. Hunt, 220 W. 57th St., New York; 1st and 3d Wed., except June and August, New York.
- AMERICAN SOCIETY OF ENGINEERING CONTRACTORS.—J. R. Wenlinger, 11 Broadway, New York; 2d Tuesday of each month, New York.
- AMERICAN SOCIETY OF MECHANICAL ENGINEERS.—Calvin W. Rice, 29 W. 39th St., New York.
- AMERICAN WOOD PRESERVERS' ASSOCIATION.—F. J. Angier, B. & O., Baltimore, Md. Next convention, January 20-22, 1914, New Orleans, La.
- ASSOCIATION OF AMERICAN RAILWAY ACCOUNTING OFFICERS.—C. G. Phillips, 143 Dearborn St., Chicago. Annual meeting, May 28, Atlantic City, N. J.
- ASSOCIATION OF RAILWAY CLAIM AGENTS.—J. R. McSherry, C. & E. I., Chicago.
- ASSOCIATION OF RAILWAY ELECTRICAL ENGINEERS.—Jos. A. Andreucetti, C. & N. W. Ry., Chicago. Annual convention, October 18-24, Chicago.
- ASSOCIATION OF RAILWAY TELEGRAPH SUPERINTENDENTS.—P. W. Drew, 112 West Adams St., Chicago.
- ASSOCIATION OF TRANSPORTATION AND CAR ACCOUNTING OFFICERS.—G. P. Conard, 75 Church St., New York.
- ASSOCIATION OF WATER LINE ACCOUNTING OFFICERS.—W. R. Evans, Chamber of Commerce, Buffalo, N. Y. Annual meeting, October 8, Philadelphia, Pa.
- BRIDGE AND BUILDING SUPPLY MEN'S ASSOCIATION.—H. A. Neally, Joseph Dixon Crucible Co., Jersey City, N. J. Meeting with American Railway Bridge and Building Association.
- CANADIAN RAILWAY CLUB.—James Powell, Grand Trunk Ry., Montreal, Que.; 2d Tuesday in month, except June, July and Aug., Montreal.
- CANADIAN SOCIETY OF CIVIL ENGINEERS.—Clement H. McLeod, 413 Dorchester St., Montreal, Que.; Thursday, Montreal.
- CAR FOREMEN'S ASSOCIATION OF CHICAGO.—Aaron Kline, 841 North 50th Court, Chicago; 2d Monday in month, Chicago.
- CENTRAL RAILWAY CLUB.—H. D. Vought, 95 Liberty St., New York; 2d Thurs. in Jan. and 2d Fri. in March, May, Sept., Nov., Buffalo, N. Y.
- CIVIL ENGINEERS' SOCIETY OF ST. PAUL.—L. S. Pomeroy, Old State Capitol building, St. Paul, Minn.; 2d Monday, except June, July, August and September, St. Paul.
- ENGINEERS' SOCIETY OF PENNSYLVANIA.—E. R. Dasher, Box 704, Harrisburg, Pa.; 1st Monday after 2d Saturday, Harrisburg, Pa.
- ENGINEERS' SOCIETY OF WESTERN PENNSYLVANIA.—E. K. Hiles, Oliver building, Pittsburgh; 1st and 3d Tuesday, Pittsburgh, Pa.
- FREIGHT CLAIM ASSOCIATION.—Warren P. Taylor, Richmond, Va.
- GENERAL SUPERINTENDENTS' ASSOCIATION OF CHICAGO.—E. S. Koller, 226 W. Adams St., Chicago; Wed. preceding 3d Thurs., Chicago.
- INTERNATIONAL RAILWAY CONGRESS.—Executive Committee, 11, rue de Louvain, Brussels, Belgium. Convention, 1915, Berlin.
- INTERNATIONAL RAILWAY FUEL ASSOCIATION.—C. G. Hall, 922 McCormick building, Chicago.
- INTERNATIONAL RAILWAY GENERAL FOREMEN'S ASSOCIATION.—Wm. Hall, 829 West Broadway, Winona, Minn.
- INTERNATIONAL RAILROAD MASTER BLACKSMITHS' ASSOCIATION.—A. L. Woodworth, Lima, Ohio.
- MAINTENANCE OF WAY & MASTER PAINTERS' ASSOCIATION OF THE UNITED STATES AND CANADA.—W. G. Wilson, Lehigh Valley, Easton, Pa.
- MASTER BOILER MAKERS' ASSOCIATION.—Harry D. Vought, 95 Liberty St., New York.
- MASTER CAR BUILDERS' ASSOCIATION.—J. W. Taylor, Old Colony building, Chicago.
- MASTER CAR AND LOCOMOTIVE PAINTERS' ASSOC. OF U. S. AND CANADA.—A. P. Dane, B. & M., Reading, Mass. Annual meeting, September 9-12, Ottawa, Can.
- NATIONAL RAILWAY APPLIANCE ASSOC.—Bruce V. Crandall, 537 So. Dearborn St., Chicago. Meetings with Am. Ry. Eng. Assoc.
- NEW ENGLAND RAILROAD CLUB.—W. E. Cade, Jr., 683 Atlantic Ave., Boston, Mass.; 2d Tuesday in month, except June, July, Aug. and Sept., Boston.
- NEW YORK RAILROAD CLUB.—H. D. Vought, 95 Liberty St., New York; 3rd Friday in month, except June, July and August, New York.
- NORTHERN RAILROAD CLUB.—C. L. Kennedy, C. M. & St. P., Duluth, Minn.; 4th Saturday, Duluth.
- PEORIA ASSOCIATION OF RAILROAD OFFICERS.—M. W. Rotchford, Union Station, Peoria; 2d Thursday.
- RAILROAD CLUB OF KANSAS CITY.—C. Manlove, 1008 Walnut St., Kansas City, Mo.; 3d Friday in month, Kansas City.
- RAILWAY BUSINESS ASSOCIATION.—Frank W. Noxon, 2 Rector St., New York. Annual dinner, second week in December, 1913, New York.
- RAILWAY CLUB OF PITTSBURGH.—J. B. Anderson, Penna. R. R., Pittsburgh, Pa.; 4th Friday in month, except June, July and August, Pittsburgh.
- RAILWAY ELECTRICAL SUPPLY MANUFACTURERS' ASSOC.—J. Scribner, 1021 Monadnock Block, Chicago. Meetings with Assoc. Ry. Elec. Engrs.
- RAILWAY FIRE PROTECTION ASSOCIATION.—C. B. Edwards, Mobile & Ohio, Mobile, Ala. Next meeting, October 7, Chicago.
- RAILWAY GARDENING ASSOCIATION.—J. S. Butterfield, Lee's Summit, Mo.
- RAILWAY DEVELOPMENT ASSOCIATION.—W. Nicholson, Kansas City Southern, Kansas City, Mo.
- RAILWAY SIGNAL ASSOCIATION.—C. C. Rosenberg, Bethlehem, Pa. Convention, October 14, Nashville, Tenn.
- RAILWAY STOREKEEPERS' ASSOCIATION.—J. P. Murphy, Box C, Collinwood, Ohio.
- RAILWAY SUPPLY MANUFACTURERS' ASSOC.—J. D. Conway, 2135 Oliver bldg., Pittsburgh, Pa. Meetings with M. M. and M. C. B. Assocs.
- RAILWAY TEL. AND TEL. APPLIANCE ASSOC.—W. E. Harkness, 284 Pearl St., New York. Meetings with Assoc. of Ry. Teleg. Sups.
- RICHMOND RAILROAD CLUB.—F. O. Robinson, Richmond, Va.; 2d Monday except June, July and August.
- ROADMASTERS' AND MAINTENANCE OF WAY ASSOCIATION.—L. C. Ryan, C. & N. W., Sterling, Ill. Convention, September 8-12, 1913, Chicago.
- ST. LOUIS RAILWAY CLUB.—B. W. Frauenthal, Union Station, St. Louis, Mo.; 2d Friday in month, except June, July and Aug., St. Louis.
- SIGNAL APPLIANCE ASSOCIATION.—F. W. Edmonds, 3868 Park Ave., New York. Meeting with annual convention Railway Signal Association.
- SOCIETY OF RAILWAY FINANCIAL OFFICERS.—C. Nyquist, La Salle St. Station, Chicago. Annual meeting, September 23-25, Chicago.
- SOUTHERN ASSOCIATION OF CAR SERVICE OFFICERS.—E. W. Sandwich, A. & W. P. Ry., Montgomery, Ala.
- SOUTHERN & SOUTHWESTERN RAILWAY CLUB.—A. J. Merrill, Grant bldg., Atlanta, Ga.; 3d Thurs., Jan., March, May, July, Sept., Nov., Atlanta.
- TOLEDO TRANSPORTATION CLUB.—J. G. Macomber, Woolson Spice Co., Toledo, Ohio; 1st Saturday, Toledo.
- TRACK SUPPLY ASSOCIATION.—W. C. Kidd, Ramapo Iron Works, Hillsburn, N. Y. Meeting with Roadmasters' and Maintenance of Way Association.
- TRAFFIC CLUB OF CHICAGO.—W. H. Wharton, La Salle Hotel, Chicago.
- TRAFFIC CLUB OF NEW YORK.—C. A. Swope, 290 Broadway, New York; last Tuesday in month, except June, July and August, New York.
- TRAFFIC CLUB OF PITTSBURGH.—D. L. Wells, Erie, Pittsburgh, Pa.; meetings monthly, Pittsburgh.
- TRAFFIC CLUB OF ST. LOUIS.—A. F. Versen, Mercantile Library building, St. Louis, Mo. Annual meeting in November. Noonday meetings October to May.
- TRAIN DESPATCHERS' ASSOCIATION OF AMERICA.—J. F. Mackie, 7042 Stewart Ave., Chicago.
- TRANSPORTATION CLUB OF BUFFALO.—J. M. Sells, Buffalo; first Saturday after first Wednesday.
- TRANSPORTATION CLUB OF DETROIT.—W. R. Hurley, L. S. & M. S., Detroit, Mich.; meetings monthly.
- TRAVELING ENGINEERS' ASSOCIATION.—W. O. Thompson, N. Y. C. & H. R., East Buffalo, N. Y.
- UTAH SOCIETY OF ENGINEERS.—Fred D. Ulmer, Oregon Short Line, Salt Lake City, Utah; 3d Friday of each month, except July and August.
- WESTERN CANADA RAILWAY CLUB.—W. H. Rosevear, P. O. Box 1707, Winnipeg, Man.; 2d Monday, except June, July and August, Winnipeg.
- WESTERN RAILWAY CLUB.—J. W. Taylor, Old Colony building, Chicago; 3d Tuesday of each month, except June, July and August.
- WESTERN SOCIETY OF ENGINEERS.—J. H. Warder, 1735 Monadnock Block, Chicago; 1st Monday in month, except July and August, Chicago.

## Traffic News.

Shipments of anthracite coal from the Pennsylvania mines in the first seven months of this year amounted to over 40,000,000 tons.

The New York, New Haven & Hartford expects that from 750,000 to 900,000 baskets of peaches will be shipped this season from the peach orchards of central Connecticut, and has put shelves in 125 ventilated cars and in 40 refrigerator cars for this service.

The Merchants' and Manufacturers' Association of Baltimore has petitioned the Interstate Commerce Commission to suspend the tariffs which have been filed by the railroads centering in Baltimore, in which a change is made in the conditions of transportation, to the effect that the railroads will no longer furnish store door delivery or make store door collections of freight in that city. In the suit before the Interstate Commerce Commission concerning store door delivery in Washington, which was decided last June, the commission held that this wagon service must be continued at Washington as long as it was kept in force in Baltimore. It appears that free delivery at Baltimore was instituted under circumstances somewhat different from those which existed at Washington, the competition with steamboats running between Baltimore and New York and other northern cities having been an element in the case.

On September 1 the Atlantic Steamship lines will put in force a rule under which, for cotton of other than the specified size of bale or density, a penalty of \$1 a bale will be imposed at the seaboard. To comply with this rule many compresses have had to be remodeled. The new crop of cotton is beginning to come in and cotton drafts are beginning to make their appearance in the market; and the question of protecting bills of lading against risk, which has been under discussion during the last two years, is up before the cotton warehouses and bankers. There is less intensity now than formerly in the agitation for protection, as during the two-year period a cotton draft business exceeding \$1,000,000,000 has been done with practically no loss. Naturally, since the revelations of the Knight-Yancy and Steele-Miller frauds, resulting from spurious bills of lading, various methods of checking up bills against actual cotton have been introduced, and gradually the possibilities of fraud have been lessened to a point which eliminates the liability to the heavy losses experienced in the past. The new steamship rule prescribes standards for size, covering, marking, density and moisture.

### How It Is Done.

Haleyville, Ala., July 31.—Yesterday the Illinois Central railroad special "Get Acquainted" train made a stop of 50 minutes here. The train on its arrival was met by a committee of the Commercial club and the railroad men were driven at once to the "Gas City" club rooms where they met the members and citizens of the town.

Judge R. L. Blanton welcomed them in an appropriate talk, laying before them the position of Haleyville and its need of competitive rates on many commodities. He expressed the kindly feelings of the inhabitants to the Illinois Central Railroad. General Freight Agent Hattendorf replied, as did several of the others, all seemingly pleased with the reception given them and the looks of progress evident around.

After a general hand shaking the visitors were driven back to their special and left for Jasper. While no promises were made the impression was made that the town would not suffer from the visit made.—*Birmingham Age Herald*.

### INTERSTATE COMMERCE COMMISSION.

The commission has suspended from August 20 until February 20, the tariff of the Boston & Maine, which contains schedules advancing rates on wool from Ayer, Lawrence, Worcester and South Wilmington, Mass., to Skowhegan and Lewiston, Me.

The commission has suspended from August 16 until February 16, the schedules contained in 55 tariffs and supplements to tariffs which proposed to cancel through joint class and com-

modity rates applicable on traffic between points located on the Kansas City & Memphis and points on or reached via the St. Louis & San Francisco.

The commission has suspended from August 23 until February 23, the supplement to the tariff of the St. Louis & San Francisco, which by the cancellation of through joint rates, leaving in effect combination rates, proposed to advance rates for the transportation of lumber and articles manufactured therefrom, c l, from points in Arkansas and Missouri to points in Iowa, Minnesota and other states.

The commission has suspended until December 13, 1913, the schedules in certain tariffs, which proposed to cancel through joint class and commodity rates now in effect between stations on the Kansas City & Memphis and points located on, or reached via the St. Louis & San Francisco, it being provided that on and after the effective dates above stated combination rates would apply which would have resulted in material advances in rates.

The commission has suspended from August 17 until December 15, the supplement to the tariff of the Central of New Jersey, which proposed to increase by over 100 per cent. rates on high explosives, viz.: powder, other than black, brown or smokeless powder; dynamite, except in forbidden forms; dry nitrocellulose, except in forbidden forms; picric acid, etc., in carload and less than carload quantities from Kenvil and other points in New Jersey to points on the Boston & Maine.

The commission has suspended from August 15 until February 15, the operation of the supplement to the tariff of the St. Louis, Rocky Mountain & Pacific, which contains schedules withdrawing the present through joint rates applicable to the transportation of bituminous coal from mines located on the St. Louis, Rocky Mountain & Pacific in New Mexico to points in Oklahoma, Nebraska, Kansas and other states located on the Rock Island Lines, and providing for the application of combination rates.

The commission has suspended from August 7 until December 5, the schedule in the tariff of the Missouri Pacific, which provides for a refrigeration charge of \$40 per car on shipments of fruits and vegetables from Denver and other Colorado points to Wichita, Hutchinson and other Kansas points. Such shipments now move under a charge of \$2.50 per ton for ice actually used in refrigerating same, and it is claimed that such icing charge never exceeds \$18 per car on shipments destined to the points above specified.

The commission has suspended until December 16, 1913, the operation of the schedules in certain tariffs, which propose to increase by 5½ cents per 100 lbs. rates on packing house products, carloads, from Mason City, Iowa, to points in Arkansas and Texas, and to increase by 7 cents per 100 lbs. rates on shipments of fresh meat, carloads, from Mason City, Iowa, to same destinations. At present packing house products from this point of origin are subject to an arbitrary of 9½ cents per 100 lbs. over the St. Louis rates to Arkansas and Texas. The present arbitrary on fresh meat, carloads, is 17 cents; the proposed arbitrary over St. Louis rates is 24 cents per 100 lbs. It is not proposed to advance similar rates from other Iowa packing house points.

### Rates on Cotton Seed and Its Products.

*In re investigation and suspension of advances in rate by carriers for the transportation of cotton seed and cotton seed products from points in Texas to New Orleans, La. Opinion by Commissioner Prouty:*

The item under suspension ruled that rates from Texas points to New Orleans, La., will not apply in connection with the Illinois Central or the Yazoo & Mississippi Valley except from points on the Sunset Central Lines. The effect of this is to restrict to certain routes the application of the export rate of 18½ cents per 100 lbs. on cotton seed and its products, from Texas points to New Orleans. The Texas & Pacific alleges that since it reaches New Orleans directly over its own rails, it should not be expected to deliver this traffic to other carriers, thereby short-hauling itself. The commission decided that it had no right to deprive the Texas & Pacific of its haul from Shreveport to New Orleans, and that that road was justified in closing the other gateways. The order of suspension was vacated. (28 I. C. C., 219.)

REVENUES AND EXPENSES OF RAILWAYS.

MONTH OF JUNE, 1913.

Table with columns: Name of road, Average mileage operated during period, Operating revenues (Freight, Passenger, inc. misc., Total), Maintenance (Way and structures, equipment, Of), Operating expenses (Traffic, portation, Trans-), General, Total, Net operating revenue (or deficit), Outside operations, net, Taxes, Operating income (or loss), Increase (or decr.) comp. with last year.

REVENUES AND EXPENSES OF RAILWAYS.

TWELVE MONTHS OF FISCAL YEAR, 1913—(CONTINUED).

Name of road.	Average mileage operated during period.	Operating revenues			Maintenance of way and structures			Operating expenses			Net operating revenue (or deficit).	Outside operations, net.	Taxes.	Operating income (or loss).	Increase (or decr.) comp. with last year.
		Freight.	Passenger.	Total.	inc. misc.	Total.	General.	Total.	Traffic.	Trans- portation.					
Southern in Mississippi.....	281	\$649,036	\$358,844	\$1,007,880	\$113,015	\$29,373	\$1,120,895	\$29,662	\$510,437	\$50,437	\$1,032,924	\$63,148	\$89,629	-\$26,481	\$126,113
Southern Kansas of Texas.....	125	1,233,480	212,394	1,503,704	100,034	100,034	1,603,738	26,725	44,126	44,126	937,095	566,609	31,159	535,450	217,746
Spokane, Portland & Seattle.....	556	3,246,231	1,682,949	5,341,465	674,202	464,202	6,005,667	55,512	1,309,604	153,024	2,696,545	2,641,521	640,800	2,000,721	159,244
Tennessee Central.....	294	1,154,131	434,171	1,684,335	339,940	173,478	1,858,313	67,935	572,080	85,489	1,238,922	445,413	50,946	394,467	116,265
Terminal R. R. Ass'n of St. Louis.....	34	.....	5,402	2,983,590	449,433	212,134	3,433,023	11,082	1,124,096	101,928	1,898,673	1,084,917	319,885	885,593	194,387
Texas & New Orleans.....	458	2,816,431	1,185,743	4,269,072	925,011	878,110	5,147,183	100,408	1,708,166	146,692	3,758,387	510,989	154,909	357,051	1,023
Toledo & Ohio Central.....	443	4,733,227	630,655	5,363,882	849,494	1,042,274	6,406,156	83,586	1,985,584	112,026	4,073,023	1,599,710	260,154	1,330,103	133,852
Toledo, Peoria & Western.....	248	826,586	480,927	1,329,961	300,203	245,668	1,575,629	29,102	1,917,970	42,305	1,135,248	1,938,826	63,887	1,874,939	21,457
Toledo, St. Louis & Western.....	451	3,715,576	388,932	4,335,167	542,644	565,563	4,900,730	162,989	1,521,208	107,853	2,900,257	1,434,910	179,505	1,255,405	235,576
Trinity & Brazos Valley.....	463	2,156,829	563,759	2,835,818	587,825	418,619	3,423,643	125,386	1,375,990	143,300	2,651,120	184,698	47,513	137,185	31,284
Ulster & Delaware.....	129	708,041	374,641	1,138,053	140,833	157,108	1,295,161	20,807	475,390	31,663	825,801	312,252	41,148	271,819	17,805
Union R. R. of Baltimore.....	9	1,495,748	281,149	1,797,641	117,403	1,097,295	2,894,936	11,936	64,823	32,852	227,014	1,570,627	69,965	1,500,662	260,294
Union R. R. of Pennsylvania.....	31	.....	.....	4,708,718	427,112	1,097,295	5,805,913	1,321	1,791,327	46,363	3,363,418	1,345,300	86,750	1,272,058	104,701
Vandalia.....	910	7,699,828	2,396,827	11,204,405	1,638,541	2,279,910	13,484,315	301,257	4,265,009	230,661	8,715,378	2,489,027	369,165	2,119,862	385,360
Victoria, Shreveport & Pacific.....	171	1,029,980	532,143	1,705,918	323,627	312,023	2,017,941	40,297	566,352	61,514	1,303,813	402,105	74,434	323,360	99,397
Virginia & Southwestern.....	240	1,585,662	174,029	1,806,626	279,700	410,422	2,217,048	23,564	496,998	43,584	2,714,046	532,358	21,300	479,098	75,855
Virginian.....	503	5,350,849	337,362	5,842,583	741,069	1,090,727	6,933,312	31,721	1,372,167	106,702	3,274,156	2,468,427	214,300	2,327,796	595,872
Wabash.....	2,515	21,774,362	7,268,289	31,769,286	4,330,278	5,330,497	37,100,000	1,025,136	13,214,059	793,519	24,693,489	7,075,797	903,892	6,115,222	1,795,748
Washington Southern.....	36	478,096	499,182	1,318,390	173,191	160,944	1,489,335	15,110	512,988	34,905	897,138	421,252	40,665	378,345	50,450
Western Ky. of Alabama.....	356	1,835,127	4,124,858	6,351,136	966,370	287,520	7,238,656	180,639	2,654,797	163,660	4,952,986	1,396,150	284,753	1,069,519	46,963
Western Ky. of Alabama.....	133	749,694	347,630	1,412,153	245,857	264,013	1,677,166	17,989	405,445	68,283	1,055,387	356,566	59,245	297,444	31,122
Yazoo & Mississippi Valley.....	1,373	7,623,031	2,507,308	10,999,673	1,597,365	1,637,222	12,636,898	180,153	4,491,719	318,360	8,624,819	2,374,854	466,491	1,911,288	635,282

Rates on Tin Cans and Fruit Baskets.

In re investigation and suspension of advances in rates by carriers for the transportation of tin cans and other commodities between points in the state of California and points in other states. Opinion by Commissioner McChord:

In the original report in this proceeding, 27 I. C. C., 298, mentioned in the Railway Age Gazette of July 4, 1913, page 31, it was held that the respondents had not justified the proposed increased rates, and the carriers were given until August 1, 1913, to establish a reasonable scale. The present rates on empty carriers, fruit baskets, etc., are low and some advances might fairly be made but the respondents have not justified the increases amounting to over 400 per cent., which would result if the changes proposed became effective. The order of suspension as to these increases will be made permanent, but the respondents may apply for a modification of this order in connection with the submission to the commission of a scale of rates materially less than would result from the change now proposed.

The carriers also proposed to advance the rating on tin cans from class C, with graduated minima, to the current Western classification rating, which is fourth class with minimum weight 14,000 lbs. The rates on tin cans from California points to points in Arizona, at which carload shipments move, in effect at the time the order of suspension was issued, have been continued in effect by the publication of specific commodity rates. The vacation of the order of suspension, therefore, will not result in an advance in these rates, and they will be permitted to become effective. (28 I. C. C., 247.)

Fourth Section Application Granted.

In re coal rates from the anthracite regions to points on the New Haven Railroad. Opinion by Commissioner Prouty:

The commission decided that on account of water competition, the respondent had the right to charge lower rates on prepared sizes of anthracite coal to Boston, Needham, Needham Heights and Newton Upper Falls, than is made to intermediate points, provided that the rate to no intermediate point shall exceed the present rate of \$3 per gross ton on prepared sizes, and that rates to Needham, Needham Heights and Newton Upper Falls shall not exceed the rate to Boston by more than 20 cents per ton. (28 I. C. C., 235.)

STATE COMMISSIONS.

Justice Gummere, of the Supreme Court of New Jersey, has issued an order staying the order of the Board of Utility Commissioners, issued early in the summer, requiring the railroads to furnish drinking water on all trains having a continuous run of half an hour or more within the state.

The Alabama state railroad commission has extended for ten days an order recently issued by it requiring the Central of Georgia and the Western of Alabama to establish uniform passenger rates on their lines in Alabama, on the basis of 2½ cents a mile. This extension was granted in order to give attorneys time to prepare briefs in the cases when they are taken before the federal courts. The roads will contend that the order is confiscatory.

ARGENTINE RAILWAYS.—Notwithstanding the considerable increase in the receipts of the Argentine railways, which, during the past year, augmented by fully 20 per cent., many of the leading Argentine lines present far from satisfactory financial condition, a fact which may be attributed to the excessively high operating expenses. Some managers take a very gloomy view of the immediate prospects, more especially in regard to the price of coal and the continual demands which are being made by all classes of the employees for increases in their already high wages. In the meantime, new lines have to be built and rolling stock renewed and added to. Last year in the Argentine republic there were 1,961 miles of new railways opened to traffic, bringing up the entire railway system of the country to 18,707 miles. During the present year there will be no cessation in new construction, and, in fact, the year 1913 will probably rank as one of the most active from a new construction point of view during the past 20 years.



## Railway Officers.

### Executive, Financial and Legal Officers.

A. D. Lightner, heretofore vice-president of the New Orleans, Texas & Mexico, has been appointed chief officer, operation and traffic, with headquarters at New Orleans, La.

W. E. Paschall has been appointed assistant treasurer of the Atlanta, Birmingham & Atlantic, the Georgia Terminal Company and the Alabama Terminal Railroad, with headquarters at Atlanta, Ga.

J. H. Lauderdale, heretofore assistant secretary and assistant treasurer of the New Orleans, Texas & Mexico, and secretary and treasurer of the Beaumont, Sour Lake & Western, has been appointed treasurer and purchasing agent of the Louisiana and the South Texas lines of the St. Louis & San Francisco, with headquarters at New Orleans, La.

The officers of the Atlantic Southern, formerly the Atlantic, Northern & Southern, are now as follows: Robert Abeles, president, St. Louis, Mo.; DeRoo Weber, first vice-president, with offices at St. Louis, and at Atlantic, Iowa; J. D. Abeles, second vice-president, and Robert Abeles, Jr., treasurer, with offices at St. Louis; and John M. Reed, secretary, with office at Des Moines, Iowa. See an item under Railway Financial News.

### Operating Officers.

T. F. Milligan has been appointed trainmaster of the Great Northern, with headquarters at Everett, Wash.

George W. Coffin has been appointed general manager of the Atlantic Southern, formerly the Atlantic, Northern & Southern, with headquarters at Atlantic, Iowa.

M. A. Neville, superintendent of the Peoria & Eastern division of the Cleveland, Cincinnati, Chicago & St. Louis, has been appointed general superintendent of the Cincinnati Northern, with headquarters at Van Wert, Ohio.

R. S. Richardson has been appointed assistant superintendent of the Halifax and St. John district of the Intercolonial and the Prince Edward Island Railways, with headquarters at Moncton, N. B., succeeding H. B. Fleming, transferred.

Frank S. Elliott, whose appointment as general superintendent of the Central district of the Great Northern, with headquarters at Great Falls, Mont., has already been announced in these columns, was born September 29, 1865, at Edyville, Iowa. He received a high school education and began railway work in July, 1882, as a telegraph operator for the Chicago, Rock Island & Pacific. From 1884 to 1889 he was employed by the Chicago, Burlington & Quincy as operator, agent and train despatcher, and the following year he was with the Atchison, Topeka & Santa Fe as train despatcher. He then went to the Northern Pacific as a train despatcher, leaving in 1904 to go to the Great Northern, where he remained until 1905, serving successively as train despatcher, chief despatcher, trainmaster and assistant superintendent of the Spokane and Cascade divisions. He was then for one year superintendent of the Denver & Rio Grande at Salt Lake City, Utah, returning to the Great Northern in 1906. For two years he was assistant superintendent of the Dakota, Kalispell, Spokane and Willmar divisions, and from 1908 to 1910 was superintendent



F. S. Elliott.

of the Northern and Dakota divisions and the Lake district. Mr. Elliott was then made assistant general superintendent of the Western district, with office at Spokane, Wash., which position he held until his recent promotion to general superintendent of the Central district, as above noted.

F. L. Brendel, superintendent of the Eastern division of the Western Maryland, at Baltimore, Md., has been appointed superintendent of the Middle division, with headquarters at Hagerstown, succeeding H. H. Berry, resigned. R. M. Johnson, inspector of transportation at Baltimore, succeeds Mr. Brendel, and his former position has been abolished.

### Traffic Officers.

W. F. Fuller has been appointed general agent of the Tidewater Southern at Modesto, Cal.

L. C. Shirah has been appointed commercial agent of the Macon & Birmingham, with office at Atlanta, Ga.

E. H. List has been appointed traveling freight agent of the Minneapolis & St. Louis, with headquarters at Chicago, succeeding J. R. Shannon, promoted.

J. F. Thompson has been appointed general agent of the freight department of the Atchison, Topeka & Santa Fe, with headquarters at Chicago, in place of G. A. Aird, deceased.

F. R. Cornell, contracting freight agent of the Wabash at Toledo, Ohio, has been appointed traveling freight agent, with headquarters at that place, succeeding J. L. Craig, promoted to Chicago territory.

Logan A. Mizener has been appointed traveling freight agent of the Chicago, St. Paul, Minneapolis & Omaha, with headquarters at St. Paul, Minn., in place of H. N. Drummond, resigned to engage in other business.

Lawrence N. Helm has been appointed general freight and passenger agent of the Ohio River & Columbus, the Cincinnati, Georgetown & Portsmouth, and the Felicity & Bethel, with office at Cincinnati, Ohio, effective September 1.

J. F. Jutz, traveling freight agent, and C. M. Rollings, traveling passenger agent, of the Union Pacific System, have been transferred from St. Louis, Mo., to Birmingham, Ala., in similar capacities. J. W. McBurney succeeds Mr. Rollings, and Frank J. Butler takes the place of Mr. Jutz.

Charles F. Stewart, superintendent of the tariff department of the Southeastern Passenger Association, at Atlanta, Ga., has been appointed general passenger agent of the Western Maryland, with headquarters at Baltimore, Md., succeeding F. M. Howell, resigned to go into other business.

Charles S. Bentley, traveling freight agent of the Delaware, Lackawanna & Western, at Cleveland, Ohio, has been promoted to commercial agent with office at Toledo. C. O. Mann, traveling freight agent at Detroit, Mich., succeeds Mr. Bentley. E. A. Farr, contracting agent at Detroit, succeeds Mr. Mann, and R. Weir succeeds Mr. Farr.

J. S. Buchanan, traveling freight and passenger agent of the Wabash, at Moberly, Mo., has been promoted to commercial agent, with office at Hannibal, Mo., succeeding Chas. J. Sayles, promoted to chief clerk in the general traffic department at St. Louis, and C. A. Shumate, chief clerk in the division freight and passenger office at Moberly, has been promoted to traveling freight and passenger agent, with office at Moberly, succeeding Mr. Buchanan.

John T. West, passenger agent of the Seaboard Air Line at Philadelphia, Pa., has been appointed division passenger agent, with office at Raleigh, N. C., succeeding H. S. Leard, resigned to go to another company. L. E. Mann, traveling passenger agent at New York, succeeds Mr. West, and C. S. Cannon succeeds Mr. Mann. W. B. Gresham, traveling passenger agent at Atlanta, Ga., has been appointed district passenger agent, with headquarters at Birmingham, Ala., succeeding Jack W. Johnson, deceased. H. R. Gray, traveling passenger agent at Tampa, Fla., succeeds Mr. Gresham; R. L. James, city ticket agent at Tampa, succeeds Mr. Gray, and George C. Myrover succeeds Mr. James. S. C. Boylston, Jr., and R. A. Garvin have been appointed passenger agents, with headquarters at Jacksonville, Fla.

**Engineering and Rolling Stock Officers.**

W. Osborne has been appointed engineer maintenance of way of the Atlantic Southern, formerly the Atlantic, Northern & Southern, with headquarters at Atlantic, Iowa.

The headquarters of J. J. Waters, superintendent of motive power of the Pere Marquette, have been moved from Grand Rapids, Mich., to Detroit; effective August 12.

Hugh Montgomery has been appointed superintendent of motive power and rolling stock of the Rutland Railroad, with office at Rutland, Vt., succeeding F. C. Cleaver, resigned.

H. C. Van Buskirk has been appointed mechanical superintendent of the First district of the Chicago, Rock Island & Pacific, with headquarters at Des Moines, Iowa, succeeding J. B. Kilpatrick, resigned.

J. E. Hood has been appointed supervisor of bridges and buildings of the Northern Pacific, with headquarters at Duluth, Minn., in place of R. E. McFarlane, who has been granted leave of absence for six months.

F. C. Stuart, signal engineer of the Texas & New Orleans, Galveston, Harrisburg & San Antonio and Morgan's Louisiana & Texas Railroad & Steamship Company, with headquarters at Houston, Tex., has resigned.

A. B. Adams, general foreman of the Gulf, Colorado & Santa Fe at Cleburne, Tex., has been appointed master mechanic of the Beaumont division, with headquarters at Silsbee, Tex., in place of J. E. McQuillen, promoted; effective August 15.

J. E. Taussig, formerly division superintendent of the Galveston, Harrisburg & San Antonio, Tex., has been appointed a special representative on the staff of E. F. Kearney, first vice-president of the Texas & Pacific, with headquarters at New Orleans, La.

W. S. Butler, master mechanic of the Huntington division of the Chesapeake & Ohio, and the Chesapeake & Ohio of Indiana, at Huntington, W. Va., has been appointed master mechanic of the West Virginia general division, with office at Hinton. F. J. Walsh, master mechanic of the Hinton division, at Hinton, has resigned to accept service with another company, and C. B. Hitch, general foreman at Covington, Ky., has been appointed general foreman, with headquarters at Hinton, W. Va.

Charles L. McIlvaine, who has been appointed master mechanic of the New York, Philadelphia & Norfolk, with office at Cape Charles, Va., as has already been announced in these columns, was born on September 25, 1876, at Wilmington, Del., and was educated at the University of Pennsylvania. He began railway work as an apprentice in October, 1899, on the Philadelphia, Baltimore & Washington, at Wilmington, and in 1901 was made special apprentice at the Pennsylvania shops at Altoona, Pa. In January, 1903, he became draughtsman at Jersey City, N. J., and in March, 1905, was appointed inspector in the motive power department at the same place. The following month he was made assistant master mechanic on the Amboy division at Camden, and in May, 1907, became assistant engineer of motive power on the Buffalo & Allegheny Valley division at Buffalo, N. Y. From September, 1910, to May, 1911, he was assistant engineer of motive power of the Philadelphia & Erie and the Northern Central, at Williamsport, Pa., and then became assistant engineer of motive power in the office of the general superintendent of motive power at Altoona, Pa., which position he held at the time of his recent appointment as master mechanic of the New York, Philadelphia & Norfolk, as above noted.

**Purchasing Officers.**

Thomas Spratt has been appointed assistant purchasing agent of the Norfolk & Western, with office at Roanoke, Va.

A. C. Mann, purchasing agent of the Central of Georgia, at Savannah, Ga., has been appointed purchasing agent of the Illinois Central, with headquarters at Chicago, succeeding J. C. Kuhns, who becomes vice-president of the Burden Sales Company, New York. J. L. Bennett, general storekeeper of the Central of Georgia at Savannah, succeeds Mr. Mann, effective September 1.

F. K. Mays, treasurer of the Atlanta, Birmingham & Atlantic, at Atlanta, Ga., has been appointed purchasing agent of that

road, also of the Georgia Terminal Company and the Alabama Terminal Railroad, in addition to other duties previously assigned to him, with headquarters at Atlanta, succeeding W. A. Hammel, resigned to go to another company, and G. E. McWhite has been appointed assistant purchasing agent.

Hollis C. Pearce, whose appointment as general purchasing agent of the Seaboard Air Line, with headquarters at Norfolk, Va., has been announced in these columns, was born on June 1,



H. C. Pearce.

1867, at Westberry, Que., Canada, and graduated in 1884 from St. Charles-Baromme College at Sherbrook, Que. He began railway work in 1885, as superintendent's clerk on the Minneapolis, Lyndale & Minnetonka, and was then conductor and later material clerk for the superintendent of construction of the same road. From September 1, 1887, to April, 1903, he was with the Minneapolis, St. Paul & Sault Ste. Marie, consecutively as clerk to the superintendent of construction for one year, clerk in the auditor's office two years, chief clerk to the general superintendent three years, general store-

keeper seven years, and purchasing agent three years. He went to the Chicago, Rock Island & Pacific in April, 1903, as assistant purchasing agent, and from May, 1904, to 1906, was general storekeeper of that road. In 1906 he was appointed general storekeeper of the Southern Pacific Company, which position he held at the time of his recent appointment to the new position of general purchasing agent of the Seaboard Air Line, as above noted.

**OBITUARY.**

John J. Coughlin, of Las Vegas, Nev., roadmaster of the Las Vegas & Tonopah, was run over by a passenger train and killed on August 7. It appears that he had fallen from his motor car. He was lying on the track, and, as the train approached, was seen by the engineman and the fireman, but there was not space in which to bring the train to a stop. Mr. Coughlin was inspecting the track from Goldfield to Bonne Clare. It is supposed that he had fainted because of the heat. The motor car, uncontrolled, ran 21 miles down grade and collided with a hand car.

**NEW BRIDGE FOR HONDURAS.**—The Honduras National Railway has accepted the \$27,928 bid of an American bridge company for the two spans (400 ft. and 100 ft., respectively) across the Uluva river at Pimienta, delivery aboard steamer at New York not later than December. The contract for erecting the Uluva river bridge has been let to an American contractor of Guatemala City, for \$15,500, with additional pay for extras.

**BADAJOS-FREGENAL RAILWAY, SPAIN.**—There is a project to construct a much-needed railway between Badajoz and Fregenal, in Seville district. These points are about 56 miles apart, and the connecting railway line would pass through long stretches of level country devoted to pasturing sheep and pigs, production of cereals, and cork forests, for which products there is at present little or no practical or convenient outlet. With these cork forests, wheat fields, and good pasture lands for sheep and pigs the region is potentially rich, and might be much more advantageously exploited if properly equipped with facilities for marketing. As projected, the railway will cross the Province of Badajoz from north to south, thus opening up a district hitherto inadequately developed because of its inaccessibility. In the past the roads have been utilized for hauling to market the produce of the Province; but this means of transportation is as slow and inconvenient as it is antiquated.

## Equipment and Supplies.

### LOCOMOTIVE BUILDING.

THE ROANOKE RAILROAD & LUMBER COMPANY has ordered 1 mogul locomotive from the Baldwin Locomotive Works.

### CAR BUILDING.

THE UNION PACIFIC is said to be considering the purchase of from 500 to 1,000 all steel box cars.

THE BINGHAM & GARFIELD has ordered 25 60-ton ore cars from the Pressed Steel Car Company.

THE BOSTON & MAINE is in the market for 1,000 gondola cars and 5,000 center sill constructions for reinforcement.

THE NEW YORK, NEW HAVEN & HARTFORD has ordered 100 steel coaches from the Osgood-Bradley Car Company.

THE MAINE CENTRAL is in the market for 6 coaches, 3 smoking cars, 2 baggage cars, 2 baggage and mail cars and 2 postal cars.

THE SWIFT REFRIGERATOR TRANSPORTATION COMPANY, Chicago, is building 250 refrigerator cars at the company's shops and is making inquiries for 250 more.

THE BUENOS AYRES & PACIFIC expects to order 100 refrigerator cars before the end of the year. O. R. Green, Buenos Ayres, Argentina, has recently been in this country in connection with this proposed order.

### IRON AND STEEL.

THE PENNSYLVANIA SYSTEM is making inquiries for 150,000 tons of rails.

**GENERAL CONDITIONS IN STEEL.**—During the past week there has been no increase in the volume of orders for new business placed, although inducements in the form of price concessions are being made to consumers. It is estimated that new orders are only about 50 per cent. of capacity. A falling off in production is predicted unless there is a marked improvement in the buying movement in the near future. Further concessions in prices will probably have to be made before this can be brought about.

### SIGNALING.

On the Nashville-Gallatin Interurban Railway, a new electric line between Nashville and Gallatin, Tenn., 27 miles long, the trains are equipped with the Simmen cab signal. The general arrangement is the same as that on the Toronto & York, the signaling of which was described in the *Railway Age Gazette*, August 6, 1909, page 248. There are home and distant contact rails at each siding, for movements in both directions. Telephone equipment is provided to enable motormen, without leaving their cabs, to communicate instantaneously with the dispatcher at any time when the motor car is in contact with a contact rail.

The New York, New Haven & Hartford has put in service at Worcester and South Worcester, Mass., all-electric interlocking plants controlling all movements at the passenger stations at each of these two places and at the same time has equipped all four of the main tracks between Worcester and South Worcester, about one mile, with automatic block signals, so arranged that by co-operation of the signalmen at the two ends of the line, any one of the tracks can at any time be used in either direction. The tracks between these two places are used by the trains of the line from Providence and that from New London. Electric current is taken from the wires of the city electric lighting company, which furnishes a duplicate service at 2,200 volts. Alternating current is used in all of the signal apparatus, and the signals are lighted by electricity. The apparatus for this installation was furnished by the Union Switch & Signal Company.

## Supply Trade News.

The Goldschmidt Thermit Company, New York, has moved its San Francisco, Cal., office from 432 Folsom street, to 329 Folsom street.

J. C. Kuhns, purchasing agent of the Illinois Central, has been made a vice-president of the Burden Sales Company, New York, with office in Chicago.

Ceresit, made by the Ceresit Waterproofing Company, Chicago, has just been awarded the Grand Prix at the world's fair, held this year at Ghent, Belgium.

The National-Standard Company, Niles, Mich., succeeds the National Cable and Manufacturing Company, Niles, Mich., and Cooks Standard Tool Company, Kalamazoo, Mich. The officers of the company are: W. F. Harrah, president; F. A. Hastings, vice-president; E. E. Cook, secretary, and W. H. Parkin, treasurer. The company handles various railroad track tools, cattle guards, positive pressure blowers, copper cables and automobile jacks.

George M. Basford, chief engineer of the railway department of Joseph T. Ryerson & Son, Chicago, has been made a member of the general executive committee of the Railway Business Association. Mr. Basford in the early months of the association, and while assistant to the president of the American Locomotive Company, New York, acted for a time as secretary of the organization, and has since kept in close touch with its work.

William G. Bee, whose appointment as vice-president and general sales manager of the Edison Storage Battery Company, Orange, N. J., was mentioned in the *Railway Age Gazette* of



W. G. Bee.

August 15, has been connected with Thomas A. Edison for the past 11 years. Mr. Bee began his business career in the electric vehicle industry, which he entered at its earliest commercial stage. His first position was with the Pope Manufacturing Company, Hartford, Conn., and in 1897 he went to the Electric Vehicle Company, of Hartford. During the Spanish War Mr. Bee served as chief gunner's mate on the *S. S. Gloucester*. After the war was over he returned to the Pope company and spent about a year in Mexico in its interests. In 1901 he had charge of that

company's exhibit at the Pan-American Exposition, at Buffalo, N. Y. In 1902 he went to the Edison company as sales manager, which position he held until his appointment as a vice-president and general sales manager of that company, as mentioned above. While with the Pope company Mr. Bee gave Mr. Edison his first ride in an electric vehicle. Mr. Bee has been responsible in a large measure for the rapid growth in the sales of the Edison storage batteries ever since they were put on the market.

The Westinghouse Electric & Manufacturing Company, Pittsburgh, Pa., has received among others orders for the following: Two 2,000 k. w., 600 v., D. C., six-phase, 25-cycle commutating-pole, self-starting rotary converters and six 375 k. v. a. 13,200 v., 25-cycle, air-blast transformers, together with one switchboard for the control of same for the Boston Elevated; and two 300 k. w., 250 v., 900 r. p. m. compound-wound, D. C., generators connected to and driven by two steam turbines through reduction gears for the Interborough Rapid Transit.

## Railway Construction.

**BROOKLYN RAPID TRANSIT.**—See New York Subways.

**BUTLER COUNTY.**—This company, which operates a line from Linstead, Mo., to Fagus, 26 miles, has been granted permission, it is said, to extend the line south to the Missouri-Arkansas state line. Application has recently been made for a charter in Arkansas to build a further extension south to Piggott, in Clay county, Ark.

**BUTTE, WISDOM & PACIFIC.**—We are told that this company's plans call for building from Divide, Mont., up the Big Hole river in Silverbow, Beaverhead and Deerlodge counties, Montana. Surveys are now being made. The principal commodities to be carried will be the product of mines; also timber and lumber, and grain, cattle and merchandise from the Big Hole country. The company hopes ultimately to extend the line in other directions. It is at present financed by the Boston & Montana Development Company, a mining company which has taken over some 2,500 acres of patented mineral ground. John G. Brown, Helena, Mont., may be addressed.

**COLUMBUS, KENTON & TOLEDO TRACTION.**—Organized in Ohio to build an interurban line from Columbus, north via Kenton. It is understood that financial arrangements are being made to build the section from Columbus to Findlay, where connection is to be made with the Toledo, Bowling Green & Southern. J. W. Caine, president, Kenton, Ohio.

**DALLAS, CORSICANA & PALESTINE.**—President L. E. Mitchell of this company, which was organized last year in Texas, with a capital of \$400,000 and headquarters at Palestine, to build from Palestine northwest through Anderson and Navarro counties to Corsicana, is quoted as saying that construction work is now under way and will be pushed to completion. (December 13, page 1162.)

**FRESNO TRACTION.**—This company, which operates a line from Fresno, Cal., has applied for permission to build an 8½-mile line from Muscatel to the new town of Biola.

**GRAND TRUNK.**—An officer writes, relative to the resumption of work on the Southern New England, between Palmer, Mass., and Providence, R. I., that the company has never stopped construction work on this line, although it has only been able to carry it along on a small scale for the last five or six months, as a result of the financial stringency. Arrangements have now been made to complete the grading on the 58-mile section in the state of Massachusetts, and this work will be completed in due course.

**GREAT NORTHERN & GULF CENTRAL.**—Organized in Texas to build from a point in Texas on the Gulf coast, northwest to Amarillo, or to some other point in the upper panhandle of Texas, about 600 miles. It is understood that the project has been financed by British capitalists and that a contract has been given to the Industrial Construction Company, Chicago, to build the line. Construction work is to be started as soon as the necessary survey, right of way, and other preliminary arrangements are completed. John Andrewatha, chief engineer, Austin, Tex.

**MISSOURI, KANSAS & TEXAS.**—An officer writes that the M. K. & T. Ry. Co. of Texas has never contemplated building nor made surveys for a line between Whitney, Tex., and Hillsboro, nor for a line from Livingston to Galveston. Surveys have been made from Weldon, which is about 17 miles westward from Trinity, to the main line, but no decision has ever been reached as to the adoption of any one of these lines nor for the construction of same.

**MOJAVE & BAKERSFIELD.**—See Southern Pacific.

**NEW YORK SUBWAYS.**—The New York Municipal Railway Corporation (Brooklyn Rapid Transit) has filed with the New York Public Service Commission, First district, plans for the reconstruction of the Sea Beach Railway as a four track depressed line from its connection with the Fourth avenue subway about Sixty-fifth street, Brooklyn, to a point immediately south of Eighty-sixth street, near Coney Island. The railroad asks permission of the commission to let the construction contract immediately, without competitive bidding, to George W. McNulty.

**NORMAN INTERURBAN.**—See Oklahoma Railway.

**OKLAHOMA RAILWAY (Electric).**—An officer of this company, which operates a line from Edmond, Okla., south, via Britton, and Oklahoma City to Moore, 24½ miles, with a western line from a point midway between Oklahoma City and Britton via Putnam City, Bethany, Yukon and Banner to El Reno, 29 miles, writes that the company is laying tracks with its own forces on an extension building under the name of the Norman Interurban Railway, from Moore, south, thence southeast to Norman, 8.2 miles. The grading work involved handling a total of 75,000 cu. yds. and was carried out by local contractors. The line has 1 per cent. grades with 4-degree curves. The company expects to carry out the plans made some time ago to build during 1914, the extension from the northern terminus at Edmond north to Guthrie, 16 miles. G. W. Knox is president and Guy Treat, chief engineer of the Norman Interurban.

**OKLAHOMA ROADS (Electric).**—Capitalists of Tulsa, Okla., and Bartlesville and Coffeyville, Kan., are said to be interested in a project to establish a through electric line from Kansas City, Mo., south to Tulsa, about 275 miles. The plans include the consolidation of existing interurban and street railway systems in Coffeyville, Independence, Cherryvale, Iola, Ottawa and Olathe, in Kansas, and in Bartlesville, Dewey and Tulsa in Oklahoma. The Kansas City-Olathe line, the Coffeyville-Cherryvale line and the short line from Bartlesville to Dewey, are to form links in the proposed through line. Harry F. Sinclair, a banker of Tulsa, is in charge of the financial arrangements.

**SOUTHERN NEW ENGLAND.**—See Grand Trunk.

**SOUTHERN PACIFIC.**—An officer writes that under the name of the Mojave & Bakersfield, a new line is to be built from Mojave, Cal., northeast to Bakersfield.

**SPRINGFIELD & PANA.**—Incorporated in Illinois with \$25,000 capital to build from Springfield, Ill., southeast to Pana, in Christian county, about 50 miles. The incorporators include J. E. Melick, C. P. McClaughlin, Springfield; A. C. Sprague and C. C. Melick, Hampton, N. J.

**SURPRISE VALLEY RAILWAY.**—An officer writes that contracts are to be let in about 40 days to build the line. The projected route is from Reynard, Nev., on the Western Pacific, north, following the North Fork Buffalo creek, thence northwest to a point immediately north of Hot Springs in Washoe County, Nev., near the California border, about 55 miles. J. E. Sexton, chief engineer, Palisade, Nev. (August 8, p. 254.)

**PASSENGER TRAFFIC OF SOUTH MANCHURIA RAILWAY.**—The passenger traffic of the South Manchuria Railway has greatly increased in recent years, having doubled in five years. The average daily number of passengers carried during 1912 on the main line was 9,293 and on the Antung line, 1,561.

**RAILWAY CONSTRUCTION IN SPAIN.**—The Belgian company owning the Ferrocarril Central de Aragon purchased and took over on June 30, 1913, the narrow gage Carinena-to-Saragossa Railway and in addition to making a connection with its own line at Saragossa will reconstruct it as a standard gage. The new Caminreal-to-Saragossa Railway joins this line at Carinena and the Chamber of Commerce of Saragossa, after an examination of the claims of the Utrillas mine owners that the road should be constructed via Utrillas, has decided against them and so reported to the government. These three lines will form a direct route from Valencia via Caminreal, Saragossa, Huesca, and Canfranc, through the new international tunnel to Oloron, near Pau, France. The port of Valencia, handicapped in its development for many years through lack of short and direct railway connection with southern France and central Spain, will benefit materially if in addition to the above line the line to Madrid can be built. Several projects for the latter have been submitted to the government from time to time during the past few years, but nothing has resulted. It was said a few months ago that the Ministerio de Fomento would present to the Cortes for its approval a law authorizing the government to let a concession for this line under the same conditions as the Lerida-to-Saint Giroms line, but the commercial bodies of Valencia requested that besides the regular subvention of \$6,710 per mile to be granted for construction, the government guarantee 5 per cent. on the entire cost of construction and as a result nothing has been done.

## Railway Financial News.

**ATLANTIC NORTHERN & SOUTHERN.**—See Atlantic Southern Railroad.

**ATLANTIC SOUTHERN RAILROAD.**—This company has been incorporated to succeed the Atlantic Northern & Southern, and has bought that portion of the Atlantic Northern & Southern running from Atlantic, Iowa, on the main line of the Chicago, Rock Island & Pacific, to Villisca, on the Chicago, Burlington & Quincy, 37 miles. The company is incorporated with \$300,000 stock, and the new officers are mentioned elsewhere in this issue.

**BIRMINGHAM, SELMA & PENSACOLA.**—This line, which runs from Brent, Ala., to Harrisburg, nine miles, has been sold to J. F. Johnston, of Tuscaloosa.

**BRINSON RAILWAY.**—This company has made an application to the Georgia Railroad Commission to issue \$2,562,500 first and refunding mortgage 30-year bonds and \$1,250,000 2-year 6 per cent. notes.

**BUFFALO & SUSQUEHANNA RAILROAD.**—The order for the sale of this property, mentioned in these columns last week, is for the sale of the railroad company's property only. The railroad company is controlled through stock ownership by the Buffalo & Susquehanna Railway, which is also in the hands of a receiver, and which also operates directly a number of miles of line.

**CHICAGO & ALTON.**—The Missouri Public Utilities Commission has approved of an issue of \$861,000 6 per cent. general mortgage bonds. These bonds are part of the total authorized issue of \$20,000,000, of which \$7,300,000 are outstanding in addition to the bonds which are now to be issued.

**CHICAGO & NORTH WESTERN.**—Kuhn, Loeb & Company, New York, have purchased and resold \$4,000,000 4½ per cent. equipment trust certificates, series C, maturing \$4,000,000 annually on July 1 from 1914 to 1923, inclusive. These certificates are secured by four switching locomotives, 2,000 gondola cars and 2,005 box cars.

See St. Louis, Peoria & Northwestern.

**KANSAS CITY, MEXICO & ORIENT.**—The reorganization committee have issued a circular in which they say:

"The plan of reorganization which the committee had hoped to issue earlier in the year had to be amended, owing to the financial situation both here and in America. The committee, however believe that this delay has not been disadvantageous, as we are now able to report that, whereas the net earnings from June 30, 1911, to June 30, 1912, on the lines in the United States, showed a deficit of \$201,000, the net earnings over the same lines from June 30, 1912, to June 30, 1913, will show a profit of approximately \$160,000. This is the more satisfactory since the new line to Alpine could not be operated until late in May, and therefore there has not yet been time to obtain the increased earnings anticipated from the connection with the Southern Pacific at Alpine.

"As the committee have now prepared a plan which can in its opinion be carried out, and which they consider will be accepted by the security holders, it has applied to the federal court in Kansas City for a decree of foreclosure with a view to buying the property. The judge on June 23 intimated that he would be prepared to sign the decree whenever the reorganization had sufficiently progressed to warrant him in so doing.

"During the last few months the committee have made further exhaustive inquiries as to the necessity of building from Wichita to Kansas City. The experts confirm the great value of completing into Kansas City and of securing the terminal facilities there, and the reorganization plan has, therefore, been prepared with this in view. The net earnings on the section from Wichita to Alpine for the coming year are estimated at \$600,000, and on the section from Kansas City to Alpine, one year after completion, at \$1,290,000, so that the committee feel justified in adopting the policy of building into Kansas City as soon as possible.

"Owing to the continued disturbed conditions in Mexico, the

present plan does not contemplate an immediate reorganization of the Mexican division. As the line completed in Mexico is only 237 miles, contrasting with 742 miles in the United States (including 13 miles joint track over the St. Louis & San Francisco), it is proposed to leave the Mexican lines in the hands of the Mexican receivers until such time as the committee can safely recommend further construction in that country. Preliminary steps have, however, already been taken to further the company's interests there.

"There are now issued and sold \$2,142,000 of receivers' certificates and \$475,000 receivers' notes, both charged on that portion of the lines in the United States. Bonds to the amount of \$18,276,000 have been deposited with the committee."

**ROCK ISLAND MEMPHIS TERMINAL CO.**—This company has been organized in Tennessee to construct and provide the terminal facilities which will be used exclusively by the Chicago, Rock Island & Pacific in Memphis, and will acquire from the Arkansas & Memphis Railway Bridge & Terminal Company real estate and franchises upon and under which exclusively Rock Island terminal facilities will be provided. The segregation of the properties will not interfere with the full discharge to the public of every obligation imposed upon the Arkansas & Memphis Railway Bridge & Terminal Company. The original incorporators are: L. P. Miles, Roane Waring, C. H. Raine, B. L. Mallory and Ernest Adams.

**ST. LOUIS, PEORIA & NORTHWESTERN.**—This company, which is a subsidiary of the Chicago & North Western, has made a mortgage to secure \$10,000,000 first 5 per cent. bonds of July 1, 1913-1948.

**ST. LOUIS, ROCKY MOUNTAIN & PACIFIC.**—The proposed sale of the securities of this company to the Atchison, Topeka & Santa Fe, mentioned in these columns last week, is subject to the following terms: The \$3,499,100 stock and \$3,699,000 bonds of the railway company which are owned by the holding company are to be sold to the A. T. & S. F. for \$3,000,000 4 per cent. 50-year bonds, to be issued by the Santa Fe, and to be secured by first mortgage on all the St. L. R. M. & P., and \$50,000 cash.

**ST. LOUIS SOUTHWESTERN.**—*The Commercial & Financial Chronicle* says that this company has bought for about \$230,000 139 acres south and east of St. Louis, title being taken in the name of the Valley Terminal Railway.

**SOUTHERN RAILWAY.**—Potter, Choate & Prentice, New York, and Drexel & Company, Philadelphia, Pa., have purchased and sold \$1,760,000 5 per cent. equipment trust certificates series R, dated August 15, 1913, and due in 20 semi-annual installments from February 1, 1914, to August 15, 1923, inclusive.

**UNION PACIFIC.**—It is understood that applications for the \$88,000,000 Southern Pacific stock represented by certificates of interest offered to Union Pacific stockholders at 88 were made for the total amount of \$220,000,000, so that applicants will receive 40 per cent. of the amount applied for. The sale of this stock was underwritten by a syndicate headed by Kuhn, Loeb & Company, New York.

**VALLEY TERMINAL RAILWAY.**—See St. Louis Southwestern.

**PROPOSED LINE FROM TANGIERS TO FEZ, AFRICA.**—Following on the treaty recently signed between France and Spain, by which a perfect understanding has been arrived at in regard to joint action and zones of influence to be observed in Morocco by the two countries, preliminary steps are proceeding apace with a view to furthering the project for the building of a railway from Tangiers to Fez, which when constructed will form a natural complement of what is undoubtedly destined to be the great international rail route for European communications with Morocco, viz., Paris, Irun, Madrid, Algeciras, Tangiers, Fez. The only break is caused by the short steamer crossing between Algeciras and Tangiers, which is accomplished in three hours and is at date a daily service. The negotiations at present completed have resulted in the formation of two companies, one in France, under the title of the Compagnie Générale du Maroc, and the other in Spain, called the Compañía General Española de Africa, whose object is to raise and apportion the necessary capital, in the proportions allotted to each country.

# ANNUAL REPORT.

## TWENTY-EIGHTH ANNUAL REPORT OF THE BUFFALO, ROCHESTER & PITTSBURGH RAILWAY COMPANY.

The Directors of the Buffalo, Rochester and Pittsburgh Railway Company submit to the Stockholders the following report for the year ending June 30, 1913:

### ROAD OPERATED.

	1913. MILES.	1912. MILES.	INCREASE. MILES.
Owned .....	360.30	356.22	4.08
Leased .....	87.29	87.28	.01
Trackage rights .....	128.87	126.32	2.55
Total length of road operated.....	576.46	569.82	6.64
Second track .....	194.89	192.42	2.47
Sidings .....	333.59	319.86	13.73
Total miles of all tracks, all steel rail.....	1,104.94	1,082.10	22.84

The increase of road operated is due to the construction of 4.08 miles of mine lines, and an adjustment of 2.56 miles in leased lines and trackage rights.

Sidings were increased 13.73 miles.

### INCOME.

	1913.	1912.	INCREASE OR DECREASE.
<b>RAIL OPERATIONS:</b>			
Operating revenues .....	\$10,947,246.06	\$9,542,367.78	\$1,404,878.28
Operating expenses .....	7,665,891.28	6,464,228.57	1,201,662.71
Net operating revenue.....	\$3,281,354.78	\$3,078,139.21	\$203,215.57
<b>OUTSIDE OPERATIONS:</b>			
Revenues .....	\$25,581.60	\$21,803.74	\$3,777.86
Expenses .....	32,946.34	21,795.66	11,150.68
Net revenue .....	Def. \$7,364.74	\$8.08	—\$7,372.82
Total net revenue.....	\$3,273,990.04	\$3,078,147.29	\$195,842.75
<b>TAXES ACCRUED</b> .....	216,000.00	204,000.00	12,000.00
Operating Income .....	\$3,057,990.04	\$2,874,147.29	\$183,842.75
<b>OTHER INCOME</b> .....	1,018,717.73	779,578.22	239,139.51
Gross corporate income.....	\$4,076,707.77	\$3,653,725.51	\$422,982.26
<b>DEDUCTIONS FOR INTEREST AND RENTALS</b> .....	1,949,713.70	1,882,830.84	66,882.86
Net corporate income.....	\$2,126,994.07	\$1,770,894.67	\$356,099.40
<b>APPROPRIATIONS:</b>			
Pension Fund .....	\$1,497.51	\$4,564.33	—\$3,066.82
Special appropriation .....	448,795.68	375,000.00	\$73,795.68
<b>TOTAL APPROPRIATIONS</b> .....	\$450,293.19	\$379,564.33	\$70,728.86
Surplus available for dividends	\$1,676,700.88	\$1,391,330.34	\$285,370.54

Taxes amounted to \$216,000, an increase of 5.88%, due to higher assessments on real estate and increased taxes imposed on gross receipts, capital stocks and loans.

A special appropriation of \$448,795.68 was made from the Net Corporate Income. Of this amount \$125,000 was paid into the Sinking Funds under Equipment Agreements Series A, B and C, of which \$5,000 was applied to retire a like amount of Equipment Bonds Series A, and the balance became available for the purchase of new rolling stock; \$114,000 was appropriated to retire a like amount of Equipment Bonds Series G; \$204,000 represents one-half of the principal of Equipment Bonds Series D, E and F paid during the year, the other half being refunded by 4½% Consolidated Mortgage bonds held in the treasury of the Company; the remainder, \$5,795.68, is the interest hitherto accrued on the sinking fund balances retained in the fund.

### DIVIDENDS.

Dividends in cash were paid on:	1913.	1912.	Increase
Preferred stock... \$6,000,000	6% \$360,000	6% \$360,000	
Common stock... 10,500,000	6% 630,000	5% 525,000	\$105,000
Total .....	\$990,000	\$885,000	\$105,000

Since the close of the fiscal year, your Board of Directors has declared a semi-annual dividend of three per cent. on the preferred stock and three per cent. on the common stock, both payable August 15, 1913.

### CAPITAL STOCK.

There has been no change during the year in this account. The total outstanding Capital Stock of the Company amounts to \$16,500,000, and consists of \$6,000,000 preferred stock and of \$10,500,000 common stock.

### FUNDED DEBT.

In accordance with the provisions of the Consolidated Mortgage of 1907, \$1,123,000 4½% bonds were issued and sold, and the proceeds applied to payment of Additions and Betterments. The Trustee also delivered to the Company \$204,000 Consolidated Mortgage 4½% bonds, representing 50% of Equipment Bonds Series D, E and F retired during the year. These bonds, added to those in the Treasury of the Company, make a total of \$1,318,000 held in reserve.

Under the terms of the Sinking Funds for the redemption of Equipment Bonds, \$527,000 bonds were retired, as follows: \$5,000 Series A; \$114,000 Series D; \$116,000 Series E; \$178,000 Series F; and \$114,000 Series G.

Equipment bonds Series G, authorized in 1910, were issued to the amount of \$159,000.

The net result is an increase of \$755,000 in the bonded debt of the Company outstanding on June 30, 1913.

### CONSTRUCTION.

The policy of making liberal appropriations for improvements has been continued, the expenditures on that account for the year amounting to \$816,020.88, as follows:

Land .....	\$91,578.86
New station, Warsaw, N. Y. ....	13,873.61
“ and office building, East Salamanca, N. Y. ....	48,265.61
“ Salamanca, N. Y. ....	37,481.98
“ Brockwayville, Pa. ....	17,398.13
“ Stanley, Pa. ....	10,009.81
Station improvements .....	18,334.14
Reservoir and pipe line, Creekside, Pa. ....	29,008.34
Water stations .....	13,986.44

Indiana tunnel improvements .....	29,423.86
Second track, Rochester, N. Y., to Scottsville, N. Y. ....	115,897.51
Increased weight of rail, frogs and fastenings .....	87,293.05
Stone ballast .....	11,558.83
Improving bridges and culverts.....	138,821.61
Telephone train dispatching lines.....	37,447.88
Sidings and yard extensions.....	117,147.13
Jacksonville mine line .....	100,543.25
Fulton Run mine line .....	7,783.39
Guthrie mine line .....	32,919.59
Tearing Run, Coy and Wallace mine lines.....	35,779.99
New roadway machinery .....	12,578.27
Automatic block signals .....	136,733.65
Additions to shops, Du Bois, Pa. ....	26,657.02
New shop machinery, Du Bois, Pa. ....	25,794.26
Other items .....	34,704.67

Total .....

CREDIT—Property transferred to Water Companies, (see page 14 of this report).....

Total .....

The following work, referred to in last year's report, was completed:

Brick station at Salamanca, N. Y.  
Reservoir and pipe lines at Ketur, Pa., and Falls Creek, Pa.  
Lining Indiana tunnel.

Jacksonville and Lucerne mine lines.  
Telephone train dispatching line on Rochester and Buffalo Divisions and the Indiana Branch.

Automatic block signals for fifty-three miles on Rochester Division.  
New brick stations were constructed at Warsaw, N. Y., Brockwayville, Pa., and Stanley, Pa.

A brick station and Divisional Office Building was built at East Salamanca, N. Y.

Among the important work, now in progress, may be mentioned:

Replacing various timber bridges, trestles and culverts in permanent form.

Guthrie mine line.  
Tearing Run, Coy and Wallace mine lines.

Telephone train dispatching line between East Salamanca, N. Y., and Butler, Pa., a distance of 180 miles.

Automatic block signals for 76 miles, from Gainesville, N. Y., to East Salamanca, N. Y., and Falls Creek, Pa., to Punxsutawney, Pa.

New yard near Rochester, N. Y.  
New roundhouse and extension of boiler and tank shops at Du Bois, Pa.

Second track, Rochester, N. Y., to Scottsville, N. Y., a distance of 11.97 miles.

In addition to the above, many passing sidings, yard and industrial tracks have been provided to meet the demands of increased business.

### EQUIPMENT.

Expenditures were made for new rolling stock as follows:	
One passenger locomotive .....	\$23,066.92
Nine freight locomotives.....	207,555.79
Three steel combination mail and baggage cars.....	31,069.84
Five steel combination baggage and express cars.....	46,532.20
Four steel coaches .....	55,975.46
Five steel passenger and smoking coaches.....	70,599.43
One hundred steel underframe flat cars.....	76,805.15
One thousand steel coal cars.....	765,597.12
One locomotive crane hoist .....	8,368.84
Four caboose cars, built at Company's shops.....	2,821.06
Four work equipment cars, built at Company's shops.....	11,110.48
Steel underframes applied on seven hundred and sixty-four gondola cars .....	40,217.56
Steel side stakes applied on six hundred and twenty-five gondola cars .....	15,384.03
Sundry other betterments, including re-classification or transfer of twelve freight train cars and fifty-five work equipment cars .....	69,788.27
	\$1,424,892.15

In addition to the above, twelve freight locomotives, three passenger locomotives, twenty-seven steel passenger train cars, and one locomotive crane hoist, were purchased, but owing to late delivery will be accounted for in next year's report.

There was credited for equipment sold, transferred or destroyed, the following values, charged in part to Operating Expenses, and the balance, representing the depreciation since June 30, 1907, charged to Reserve for Accrued Depreciation:

Seven locomotives .....	\$44,193.44
Two passenger train cars.....	2,291.26
Five hundred and sixteen freight train cars.....	205,218.46
Twenty-eight work equipment cars.....	21,019.82
	272,722.98

Making a net increase of.....

The total tractive power of engines aggregates 9,932,893 pounds, an increase of 310,733 pounds over last year. The average tractive power of each engine increased 837 pounds, being 34,017 pounds as against 33,180 pounds last year.

The total carrying capacity of cars in freight service now amounts to 708,813 tons, an increase of 40,069 tons over last year. The average carrying capacity or efficiency of each freight car increased 1.03 tons, being 41.26 tons as against 40.23 tons last year.

The reserve for accrued depreciation of equipment owned on June 30, 1913, amounted to \$1,644,437.85.

The accrued depreciation on leased equipment, now aggregating \$173,424.57, in accordance with the requirements of the Interstate Commerce Commission accounting, has been credited to a suspense account, for adjustment at the time the equipment is surrendered.

### PASSENGER REVENUES.

The gross passenger revenue, the largest in the history of the Company, amounted to \$1,127,612.12, a gain of 6.55 per cent., or \$69,351.70.

The average rate received per passenger per mile decreased .005 cents, being 2.066 cents as compared with 2.071 cents a year ago.

The average distance each passenger was carried increased .67 miles, being 26.98 miles, against 26.31 miles last year.

Passengers carried in 1913.....	2,023,020	
Passengers carried in 1912.....	1,942,226	
An increase of 4.16 per cent., or.....		80,794
Passengers carried one mile in 1913.....	54,573,203	
Passengers carried one mile in 1912.....	51,101,188	
An increase of 6.79 per cent., or.....		3,472,015

## FREIGHT REVENUES.

The average rate received per ton per mile decreased .19 mills, being 4.61 mills as compared with 4.80 mills last year.

The average distance each ton was hauled increased 4.04 miles being 163.35 miles, against 159.31 miles a year ago.

The revenue tonnage moved was also the largest in the history of the Company, all of the general commodities showing increases, as follows:

	1913.	1912.	INCREASE.
Bituminous coal.....	7,980,204	7,188,280	791,924
Coke.....	593,447	538,452	54,995
Iron ore.....	781,201	263,574	517,627
Pig and bloom iron.....	310,374	231,857	78,517
Other freight.....	2,825,382	2,475,986	349,396

Total.....	12,490,608	10,698,149	1,792,459
An increase of 16.75 per cent., or.....			

Tons moved one mile in 1913.....	2,040,358,520
Tons moved one mile in 1912.....	1,704,307,001

An increase of 19.72 per cent., or.....	336,051,519
---	-------------

The result for the year is a gain of 15.13 per cent., or \$1,237,150.20 in gross freight revenue.

## EXPENSES.

Operating Expenses increased \$1,201,662.71 or 18.59 per cent., due principally to the larger volume of traffic, necessitating proportionate outlays in all departments.

The expenses were further increased by the advances made in wages of employees, the higher cost of materials, and, in addition to the ordinary Maintenance charges, by expenditures for the improvement of track and rolling stock required by higher standards of efficiency.

The operating ratio increased 2.29 per cent., being 70.03 per cent., against 67.74 per cent. last year.

The percentage of each group of operating expenses to gross earnings for the past five years, is as follows:

	1913.	1912.	1911.	1910.	1909.
Maintenance of way.....	14.23	12.52	12.57	13.65	10.72
Maintenance of equipment.....	19.74	18.94	19.35	20.78	21.45
Traffic.....	1.30	1.26	1.44	1.35	1.41
Transportation.....	32.71	32.88	32.11	28.55	29.22
General.....	2.05	2.14	1.81	1.74	2.25
Total.....	70.03	67.74	67.28	66.07	65.05

The average cost per ton per mile is 3.00 mills, being .01 mill less than last year.

The average number of revenue tons carried one mile per revenue freight train mile, excluding the mileage of helping engines, increased 62.63 tons, being 710.04 tons, against 647.41 tons a year ago.

The average number of revenue tons carried one mile per revenue freight engine mile, including the mileage of helping engines, increased 23 tons, being 462, against 439 a year ago.

The averages for the past ten years are as follows:

YEAR.	TRAIN LOAD.	ENGINE LOAD.
1904.....	439	357
1905.....	507	374
1906.....	525	418
1907.....	543	435
1908.....	530	371
1909.....	597	400
1910.....	638	420
1911.....	635	430
1912.....	647	439
1913.....	710	462

The average number of revenue passengers carried one mile per revenue passenger train mile is 39, being 1 more than last year.

The non-revenue traffic, not included in any of the other figures of this report, is as follows:

	1913.	1912.
Number of passengers.....	331,305	275,546
Number of passengers carried one mile.....	12,820,161	10,880,382
Number of tons.....	1,117,413	972,545
Number of tons carried one mile.....	99,797,191	88,403,527

## LEASED LINES.

Advances were made to leased lines for additions and betterment expenditures, as follows:

## ALLEGHENY &amp; WESTERN RAILWAY.

Land.....	\$11,544.43
Grade revisions and changes of line.....	45,461.98
Track fastenings and other material.....	9,978.03
Sidings and spur tracks.....	44,152.68
Branch, Craigs ville, Pa.....	32,137.70
Terminal yards.....	4,615.27
Improvements at Allegheny station, Pittsburgh, Pa.....	3,835.69
Total.....	\$151,725.78

Excepting the branch at Craigs ville, Pa, still under way, all of the work mentioned above is completed.

## CLEARFIELD &amp; MAHONING RAILWAY.

Land.....	\$4,378.75
Increased weight of rails.....	1,423.09
Track fastenings and other material.....	5,500.20
Sidings and spur tracks.....	14,505.89
Installation of telephone train despatching system.....	4,434.06
Water and fuel stations.....	4,286.23
Improvements at Clearfield station, Pa.....	693.17
Total.....	\$35,221.39

Less—Abandoned sidings and spur tracks:	
Rockton mine line.....	\$15,874.10
Other sidings.....	1,118.35
Total.....	\$16,992.45

Total.....	\$18,228.94
All of the above work is completed.	

## FIRE INSURANCE FUND.

The assets of this fund were increased \$22,796.03 during the year, and now amount to \$259,544.15 in interest-bearing securities and cash.

## PENSION FUND.

The assets in this fund, created July 1, 1903, were increased \$13,633.08 during the year, and now amount to \$190,952.78 in interest-bearing securities and cash.

There were fifty-eight pensioners upon the roll on June 30, 1913, a net increase of seven during the year.

## GENERAL REMARKS.

The Ontario Car Ferry Company, Limited, paid a dividend of 5% for the year ending December 31, 1912. The sum of \$12,485 received on the \$249,700 of this Company's stock was credited to Other Income account.

Loans amounting to \$75,150 were made to the realty company organized to acquire and hold real estate, referred to in former reports, making a total of \$373,000 advanced to date.

In order to maintain water rights in Pennsylvania and protect the supply of good water, independent companies were created and capitalized as follows:

	Stock.	6% Bonds.
Ketner Water Co.....	\$92,000	\$50,000
Kyle Water Co.....	85,000	170,000
Cloe Water Co.....	55,000	65,000
Cummings Water Co.....	60,000	10,000

Total.....	\$292,000	\$295,000
------------	-----------	-----------

The entire amount of these securities was issued to your company to reimburse it for the reservoirs and other property transferred.

Mr. Lewis Iaelin was, on November 18, 1912, elected a Director to fill the vacancy in the Board caused by the resignation of Mr. Harry Yates.

The acknowledgments of the Board are renewed to the officers and employees for their faithful and efficient services.

Statements and statistics of the operation of your road for the year are submitted herewith.

By order of the Board,

WILLIAM T. NOONAN,  
President.

ROCHESTER, N. Y., July 30th, 1913.

## COMPARATIVE INCOME ACCOUNT.

	OPERATING REVENUES.	1913.	1912.	INCREASE OR DECREASE.
<b>RAIL OPERATIONS—</b>				
<b>FREIGHT—</b>				
Coal.....	\$5,849,292.16	\$5,281,501.21	\$567,790.95	
Coke.....	529,047.49	571,451.60	—42,404.11	
Merchandise.....	3,033,539.00	2,321,775.64	711,763.36	
Total.....	\$9,411,878.65	\$8,174,728.45	\$1,237,150.20	
<b>PASSENGER</b>	1,127,612.12	1,058,260.42	69,351.70	
<b>OTHER TRANSPORTATION—</b>				
Excess baggage.....	10,851.22	10,386.00	465.22	
Mails.....	50,368.92	50,247.21	121.71	
Express.....	92,013.93	82,558.39	9,455.54	
Milk.....	15,439.63	15,007.56	432.07	
Switching.....	120,260.15	104,256.38	16,003.77	
Sundry sources.....	4,757.27	3,290.44	1,466.83	
Total.....	\$293,691.12	\$265,745.98	\$27,945.14	
<b>OTHER OPERATIONS—</b>				
Station and train privileges.....	3,857.04	3,863.71	—6.67	
Car service.....	21,688.00	5,565.00	16,123.00	
Ganson St. Docks.....	78,466.50	29,043.85	49,422.65	
Sundry sources.....	10,052.63	5,160.37	4,892.26	
Total.....	\$114,064.17	\$43,632.93	\$70,431.24	
<b>TOTAL OPERATING REVENUES</b>	\$10,947,246.06	\$9,542,367.78	\$1,404,878.28	
<b>OPERATING EXPENSES.</b>				
Maintenance of way.....	\$1,557,963.28	\$1,195,262.96	\$362,700.32	
Maintenance of Equipment.....	2,161,210.43	1,807,076.51	354,133.92	
Traffic expenses.....	141,659.31	120,108.16	21,551.15	
Transportation expenses.....	3,580,617.38	3,137,299.76	443,317.62	
General expenses.....	224,440.88	204,481.18	19,959.70	
Total.....	\$7,665,891.28	\$6,464,228.57	\$1,201,662.71	
<b>NET OPERATING REVENUE..</b>	\$3,281,354.78	\$3,078,139.21	\$203,215.57	
<b>OUTSIDE OPERATIONS—</b>				
Net revenue.....		\$8.08		
Net deficit.....	\$7,364.74		—\$7,372.82	
<b>TOTAL NET REVENUE.....</b>	\$3,273,990.04	\$3,078,147.29	\$195,842.75	
<b>TAXES ACCRUED.....</b>	216,000.00	204,000.00	12,000.00	
<b>OPERATING INCOME.....</b>	\$3,057,990.04	\$2,874,147.29	\$183,842.75	
<b>TOTAL OTHER INCOME.....</b>	\$1,018,717.73	\$779,578.22	\$239,139.51	
<b>GROSS CORPORATE INCOME..</b>	\$4,076,707.77	\$3,653,725.51	\$422,982.26	
<b>DEDUCTIONS FROM GROSS CORPORATE INCOME.</b>				
RENTS—Total.....	\$320,303.93	\$301,016.51	\$19,287.42	
INTEREST ACCRUED ON FUNDED DEBT.....	\$1,255,909.77	\$1,207,895.14	\$48,014.63	
Interest on Loans.....		419.19	—419.19	
Total DEDUCTIONS.....	\$1,949,713.70	\$1,882,830.84	\$66,882.86	
<b>NET CORPORATE INCOME..</b>	\$2,126,994.07	\$1,770,894.67	\$356,099.40	
<b>DISPOSITION OF NET CORPORATE INCOME.</b>				
<b>APPROPRIATIONS—</b>				
Pension Fund.....	\$1,497.51	\$4,564.33	—\$3,066.82	
New Equipment.....	125,795.68	125,000.00	795.68	
Retirement of bonds.....	323,000.00	250,000.00	73,000.00	
<b>DIVIDENDS DECLARED—</b>				
<b>PREFERRED STOCK—</b>				
(No. 38) 3% on \$6,000,000.....	180,000.00	180,000.00		
(No. 39) 3% on \$6,000,000.....	180,000.00	180,000.00		
<b>COMMON STOCK—</b>				
(No. 25) 3% on \$10,500,000.....	315,000.00	262,500.00	52,500.00	
(No. 26) 3% on \$10,500,000.....	315,000.00	262,500.00	52,500.00	
Total Charges.....	\$1,440,293.19	\$1,264,564.33	\$175,728.86	
<b>BALANCE TO PROFIT AND LOSS..</b>	\$686,700.88	\$506,330.34	\$180,370.54	

# Railway Age Gazette

PUBLISHED EVERY FRIDAY AND DAILY EIGHT TIMES IN JUNE, BY THE  
SIMMONS-BOARDMAN PUBLISHING COMPANY,  
WOOLWORTH BUILDING, NEW YORK.

CHICAGO: Transportation Bldg. CLEVELAND: Citizens' Bldg.  
LONDON: Queen Anne's Chambers, Westminster.

E. A. SIMMONS, *President.*

L. B. SHERMAN, *Vice-President.* HENRY LEE, *Sec'y & Treas.*  
The address of the company is the address of the officers.

**EDITORS.**

SAMUEL O. DUNN, *Editor.*

ROY V. WRIGHT,  
*Managing Editor.*  
W. E. HOOPER  
B. B. ADAMS  
E. T. HOWSON

H. H. SIMMONS  
H. F. LANE  
E. A. AVERILL  
R. E. TRAYNER  
A. C. LOUDON  
E. S. FAUST  
F. W. KRAEGER  
A. D. CLOUD  
GEORGE L. FOWLER

Subscriptions, including 52 regular weekly issues and special daily editions published from time to time in New York, or in places other than New York, payable in advance and postage free:

United States and Mexico.....	\$5.00
Canada.....	6.00
Foreign Countries (excepting daily editions).....	8.00
Single Copies.....	15 cents each

Engineering and Maintenance of Way Edition and four Maintenance of Way Convention Daily issues, North America, \$1.00; foreign, \$2.00.

Entered at the Post Office at New York, N. Y., as mail matter of the second class.

WE GUARANTEE, that of this issue 8,150 copies were printed; that of those 8,150 copies, 6,700 were mailed to regular paid subscribers and 849 were provided for counter and news companies' sales; that the total copies printed this year to date were 802,859—an average of 8,636 copies a week.

VOLUME 55. AUGUST 29, 1913. NUMBER 9.

## CONTENTS

**EDITORIAL:**

Editorial Notes.....	357
The Causes of and Remedies for Car Shortages.....	359
Grade Crossings and Automobiles.....	360
American Locomotive Company.....	362
New Books.....	363

**LETTERS TO THE EDITOR:**

A Well-Qualified Critic; by F. J. Lisman.....	363
Car Movement and Interchange; by Arthur Hale.....	363
A Claim of the Commission; by Avery Turner.....	364
Locomotive Boiler Circulation; by C. T. Rommel.....	364

**MISCELLANEOUS:**

*Construction of New Quebec Bridge Piers; by H. P. Borden.....	365
Master Blacksmiths' Association.....	369
Increasing Freight Car Efficiency; by B. A. Worthington.....	371
*William P. Clough.....	372
*J. M. Hannaford.....	373
The Sayings of Stubbs.....	373
American Association of Railroad Superintendents.....	374
*Heavy Power for the Northern Pacific.....	377
Pennsylvania Public Service Company Law.....	379
*Nomographic Method for Finding Center of Gravity and Moment of Inertia.....	381
Foreign Railway Notes.....	364, 372, 373, 377, 378

**GENERAL NEWS SECTION.....** 386

\*Illustrated.

is now practically ready for electric operation. The Pacific Electric system in southern California, which is also a Southern Pacific property, is not involved in the present controversy, as it is operated separately. The most important demands of the employees are that seniority rights in steam service on all lines of the coast system, including the territory from El Paso to Portland, be extended over the electrified lines, and that the rates of pay in steam service be applied on the electric system. A strike vote has been taken, and representatives of the roads and of the men have been in conference in San Francisco for two or three weeks. The extension of seniority rights over the electric lines, as demanded, would mean that any locomotive engineer, for instance, could claim an electric run without any previous training for the special duties of a motorman. The demands for equality in pay ignore the fact that the qualifications and experience necessary for motormen on electric trains are much less than for locomotive engineers, and also that conditions such as heavy tonnage, which have made possible and necessary previous increases in the wages of men in steam railway service, do not exist in electric service. The duties of trainmen on the Southern Pacific electric lines are essentially the same as those on high-class interurban lines, and the wages paid compare favorably with those ordinarily paid in such service. To raise the wages of employees on these electric lines to the same basis as those on steam lines would undoubtedly be the first step toward forcing up wages on all electric lines. One of the important economies attained by electric lines has resulted from the lower wages they have paid train and enginemen, and to eliminate this economy, as the labor organizations are trying to do, would seriously affect further developments along the line of electrification.

AT the Master Blacksmiths' Association convention at Richmond, Va., last week a report was presented by the committee which was appointed to confer with the Master Mechanics' Association with a view to obtaining the co-operation of the latter body in increasing the attendance of the smith shop foremen at the Blacksmiths' convention. During the presentation of the report, the chairman of the committee read an editorial on this subject which appeared in the *Daily Railway Age Gazette*, June 18, 1913. Aside from the value of the papers read and the discussion engaged in, anyone who attends one of these conventions can scarcely help being impressed with the manner in which those attending the convention grasp the opportunities for the exchange of methods and ideas, whether in the meetings or outside. There are numerous cases where men have obtained at these conventions ideas which, when put into practice on their return home, have saved their companies considerable money. Some railroad companies gladly send their foremen to the conventions and pay their expenses while there, and it is quite probable that in many cases, aside from the broadening effects that such meetings are bound to produce, the direct savings possible through the interchange of ideas will much more than offset the expenditure incurred in sending them. There is, however, a side to this question which the members, not only of the Master Blacksmiths' Association, but of all the smaller associations, should not overlook, and that is the fact that there are at least ten such associations allied to the mechanical department alone. These each have memberships ranging from 150 to 1,000, all of whom should have their expenses paid if it is allowed in any one case. Taking the standpoint of the higher railroad officer it can be readily seen that there must be a limit and this is unquestionably the explanation, in a number of cases, for the disinclination to pay expenses to any convention. Undoubtedly the railroads should for their own benefit encourage attendance at these conventions, but considering the number of such associations and the extent of their membership, can it not be considered sufficient encouragement if the members are allowed the time at the conventions with full pay and their transportation?

THE attitude which has been assumed by the engine and trainmen's organizations of the Southern Pacific with reference to the operation of trains on the company's electrified lines, will, if maintained, seriously retard the further electrification of branch lines, which has received much consideration, especially in the West. While the present controversy relates only to Southern Pacific lines, it is generally regarded as presenting a test case, which, if won by the unions, will affect conditions of employment on other roads. The Southern Pacific substituted electric for steam power on its suburban lines in the vicinity of Oakland, Cal., two years ago. It also recently organized the Portland, Eugene & Eastern to take over and electrify its branch lines from Portland, Oregon, south to Eugene, and a portion of this system



THERE is hardly another railway association in the country whose development is better entitled to encouragement from the higher officers of the railways than the American Association of Railroad Superintendents, which held its annual meeting in Chicago last week. There are many organizations of railway officials, and doubtless the executive officers sometimes grow impatient because of the amount of time that their subordinates take in attending conventions. But probably nobody who is familiar with the facts would seriously question that the work of such organizations as the American Railway Engineering Association, the Master Mechanics' and Master Car Builders' Associations, the Railway Signal Association, the Association of Transportation and Car Accounting Officers, and the Train Dispatchers' Association have contributed much toward increasing the efficiency of railway operation. Now there is no strong organization corresponding to these in the distinctively transportation field, in other words, no strong organization which devotes itself to the detailed study of the numerous questions pertaining to the movement of cars and trains. The American Railway Association is a supreme court of appeal on all operating matters rather than a body which devotes itself to dealing in detail with the technique of car and train movement. A great deal of study has been given for years to the efficient construction and maintenance of track, structures and equipment. There has been no comparable study of methods for increasing the safety and efficiency with which track, structures and equipment are operated. Probably it is largely due to this that two of the greatest problems now confronting the railway managements of America are those of reducing accidents and getting a ton mileage per day and per year out of locomotives and cars proportionate to their tractive power and capacity. In order that equipment and structures may be not only efficiently developed and maintained, but also efficiently worked, it is essential that methods for getting them satisfactorily loaded and satisfactorily moved shall be studied, developed and refined with the same laboriousness, perseverance and thoroughness as the various features of construction and maintenance. It would seem that an organization composed of general superintendents, superintendents, trainmasters and yardmasters could do the needful work much better than an organization such as the American Railway Association, composed chiefly of executive officials, could possibly do it. The American Association of Railroad Superintendents is now composed of railway officers of most of these classes, but it needs encouragement and support from the higher officers in order to enable it to live up to its possibilities. The engineering and mechanical officers are chiefly staff officers. Those concerned with car and train handling are line officers. American railways will be more efficiently operated when there is as much scientific study devoted to the work of the line as there is given to the work of the staff. The best ways in which to strengthen the American Association of Railroad Superintendents would be for the general managers to instruct their superintendents to attend and participate in its meetings.

WHILE the Association of Railroad Superintendents deserves encouragement, it was very unfortunate in the selection of one of its speakers. W. W. Wheatly, who evidently considers himself an authority on railway economics, delivered an address in which he repeated every stale slander on the management of American railroads and drew every false inference from their statistics with which the muckrakers have regaled the country during the last ten years. Mr. Wheatly sought to show, among other things, that the increases in the expenses of the railways have not been due chiefly to the increases in wages, but to increases in what the roads have paid for supplies and equipment. These increases in the costs of supplies and equipment he attributed to improper financial relations between the railways and the large trusts and banking interests. Now, it is true that there

have been heavy increases in the cost of materials and supplies. It is also true that there have been and are dubious relations between some railway systems and some large industrial and banking concerns. But it is absurd to attribute the greater part of the total increase in railway expenses to this cause. The increase in the other expenses of railways has not been anywhere near as great, either absolutely or in proportion, as the increase in the wages paid by them. The following table containing statistics of the Interstate Commerce Commission for 1902 and 1912 demolishes Mr. Wheatly's theory:

	1902.	1912. (Railways earning over \$100,000 gross)	Increase.	Per Cent. Inc.
Total operating revenues..	\$1,726,380,267	\$2,826,917,967	\$1,100,537,700	64.6
Total operating expenses..	1,116,248,747	1,958,963,431	842,714,684	75.5
Total compensation of employees .....	672,028,592	1,243,113,172	571,084,580	84.9
Total other expenses.....	444,220,155	715,850,259	271,630,104	61.1
Ratio of compensation of employees to total earnings, per cent.....	38.9	43.9		
Ratio of compensation of employees to total expenses, per cent.....	62.4	63.4		

It will be seen that expenses aside from compensation of employees, which include all expenditures for equipment, supplies, etc., increased during this ten years only 61 per cent., while the total compensation of employees increased almost 85 per cent. The increase in the compensation of employees added \$571,000,000 to railway expenses; the increase in other expenses added only \$271,000,000, or less than half as much. The consequence was that in 1902 the compensation of employees was only 62.4 per cent. of total operating expenses, while in 1912 it was 63.4 per cent. of total operating expenses. The increase in other operating expenses was less in proportion than the increase either in total wages, total expenses or total operating revenues. Mr. Wheatly also went on to repeat the stock charges of the demagogue and the muckraker that the capitalization of railways has been increasing inordinately, and that this, together with the inflation of operating expenses that he alleged has been occurring, has been increasing the cost of living. Increases in railway expenses and capitalization could not increase the cost of living unless they caused increases in the rates that had to be paid by travelers and shippers. Now, the average rate per passenger mile in the United States in 1902 was 1.986 cents, and in 1912 it was 1.985 cents; and in 1902 the average rate per ton mile was .753 cent, and in 1912, .743 cent. In other words, both passenger rates and freight rates were lower at the end of the decade than they were at its beginning. Just how, when rates remained stationary or declined, railway financing and operation can have increased the cost of living, we leave Mr. Wheatly to explain.

SILENT Signals Spell Sound Sleep. This is the introduction to an advertisement of the Chicago & Eastern Illinois in which the line of that road between Chicago and St. Louis is characterized as "The Noiseless Route." "No shouts and yells of trainmen" will disturb the sleep of passengers on the night express. Employees are "sworn to silence." This advertisement is warmly to be commended. Unless the C. & E. I. is better than most roads the rule will be broken a good many times, and the advertising manager will receive complaints and will have to complain to the superintendent that the preaching and the practice are not being made to correspond; but it is good, nevertheless, to set a high standard, and to let it be known to the public. The ideal having been published in the newspapers, all hands will have a stronger incentive to live up to it. And the high degree of noiselessness already attained on our best roads is only an added reason for making the requirements still more strict; passengers make so many all-night journeys with no disturbance whatever that a single occasional

offense becomes a notable annoyance. Without putting the slightest emphasis on the name of the Chicago & Eastern Illinois, or of any other one road, we would suggest that the trainmen and switchmen are not the only offenders. Various other night noises frequently annoy the sleeping-car sleeper. The train advertised by the C. & E. I., like others on many roads, starts out at midnight. Many passengers find it convenient to board such trains at 11 o'clock, or earlier; and in summer they thus lie by an open window in the station for an hour, and may wish to sleep. Among the things which in such circumstances prevent sleep are the pop valves of waiting locomotives, and the noisy trucks of the men loading express matter, mail bags and baggage. The fact is that in undertaking to make a big station quiet, even in the night, the railroad manager makes a big contract, and a good many different people have got to be "jacked up" now and then. Not unnaturally, the switching crews in the freight yard—who often bang the cars so that the noise penetrates the ears of passengers many rods distant—look upon the demands of the sleeping passengers as pretty stiff, and as based on refinements that working men cannot sympathize with; nevertheless, passengers have acquired the habit of expecting quiet; in the great majority of cases it is easy to accommodate them, and therefore there is nothing to do but strive for perfection. And in abating nuisances the superintendent or trainmaster can do good work with sights and smells, as well as noises. Often a passenger in a berth has some little trouble in adjusting the curtains so as to avoid annoyance from a powerful electric light. Barrels of fish on a baggage truck, under the car window, sometimes make a passenger wish that he had gone by another road. If the waiting sleeper is set on a track out in the yard, to avoid the noises in the shed, offensive odors from adjoining buildings, swamps or gutters sometimes intrude. Live stock trains are sometimes stopped alongside of passenger trains needlessly. The officer who sets out to straighten all unpleasant things of this kind may be tempted to think that he is wasting his time on excessive refinement; but "trifles make perfection."

THE state of Pennsylvania has put itself in the rapidly growing list of states having a "strong" railroad commission. The former commission of three members, possessing few and comparatively mild powers, is metamorphosed into one of seven members with ten-thousand-dollar salaries and ten-year terms. The new law, briefly noticed in our issue of August 8, page 238, is abstracted on another page of this number. Large salaries do not insure competent commissioners—as has been evident in New York since weak governors have taken the place of Governor Hughes—but Governor Tener of Pennsylvania has made a beginning which seems to be regarded in that state as highly commendable. From the standpoint of the science of railroad-ing, as well as of true public spirit, he could not have done better than he did in selecting Prof. Emory R. Johnson; and in appointing a banker, an experienced street railroad operating officer, a former state treasurer and a former governor, he showed exceptional appreciation of the importance of the commissionerships. Those parts of the new law which impose new burdens and enlarge and stiffen the regulative powers of the commission do not go into effect until next January, the duty of the commission for the next four months being mainly to finish up the business of the former railroad commission. This law will be notable not so much because of its general character—which is much like that of the law of New York, which has been in force now for six years, interpreted by the strong, intelligent and public spirited Stevens commission—as from its detailed phraseology and from its existence in a state which has an enormous railroad traffic yet never before has subjected the railroads to much regulation. In phraseology and arrangement this law appears to be an original work—it is said to have been drawn mostly by Dean Lewis of the University of Pennsylvania

Law School—and it is unusually clear and easy to read, though it is very long. Not improbably in the course of years it will clarify many points for the courts and for the commissions of other states. The establishment of a commission of strong men in a state like Pennsylvania is, indeed, an event big with possibilities. The Pennsylvania Railroad is in many respects the greatest railroad institution in the world, and the Pittsburgh district has what is probably the densest freight traffic in the world, considering the extent of the territory. The Reading is also a great institution and the rates for the transportation of anthracite coal are of interest to fifty millions of people. Governor Tener has only partially got away from the vicious idea that a state regulator of railroads must know nothing about the railroad business; so there is no danger of revolutionary action by the commission. This point, by the way, is one that will have to be taken up and settled sometime. Knowledge of railroading is absolutely essential; shall commissioners acquire it by slow study; or shall they hire it? Or are we to go forever on the assumption that railroad experts possessing patriotism and public spirit cannot be found? There seems to be only one railroad expert on this commission—Prof. Johnson—for the electric railroad manager has been selected, no doubt, with a view to having him give his time wholly to interurban and street railroad matters. Commissions which deal with all kinds of public service are in danger of being classed as jacks at all trades, and masters of none.

#### THE CAUSES OF AND REMEDIES FOR CAR SHORTAGES.

LAST year and again this year the railways have issued warnings to shippers and consignees that shortages of freight cars were impending. The warnings have been accompanied by appeals for the shipping public to co-operate with the roads in efforts to restrict the shortages and their harmful effects to the practicable minimum. The railways in issuing these warnings and appeals have rendered a courtesy and a service to their patrons. Their patrons have everything to gain and nothing to lose by extending the co-operation for which the roads ask. Some of our esteemed contemporaries, including the *Chicago Examiner* (August 3, 1913) and the *Buffalo Times* (August 21, 1913) have grown editorially cynical about the warnings issued by the railways. They have also fallen into serious errors in their statements of fact regarding the car situation. They have implied that deficiencies of rolling stock have become of annual occurrence; and the *Buffalo Times* has even been so far misled as to conclude a lucubration with the remark, "the shipping and receiving public will welcome with keen enthusiasm the appearance on the stage of that hitherto unfamiliar artist Car Surplus.

The implication that car shortages have been occurring in the United States every year is incorrect. There were shortages in 1907, 1909, and 1912, but there was none in 1908, 1910 or 1911. Furthermore, contrary to the *Buffalo Times*, the great artist "Car Surplus" has been appearing on the stage in recent years much more frequently and staying for much longer periods than has "Car Shortage." The American Railway Association between January 2, 1907, and July 15, 1913, made 162 fortnightly reports on the car situation, and 139 of these showed net car surpluses. In other words, "Car Surplus" made six times as many appearances as "Car Shortage." Furthermore, the net surpluses have been very much larger than the net shortages. Only twice in six and one-half years have shortages exceeding 100,000 cars been reported, while surpluses varying from 100,000 to over 400,000 cars have been reported 76 times; and surpluses exceeding 200,000 cars have been reported 36 times.

The amount of freight traffic delivered to the railways fluctuates violently in different parts of the year; and this is the main explanation of car shortages. The largest month's business in a given year often exceeds the smallest month's business by 50 per cent. The railways have their "rush months" of freight

traffic just as urban and suburban railway systems have their "rush hours" of passenger traffic. The "rush months" of the railways come in the fall and early winter. In order that the railways might handle their "rush months" traffic as expeditiously and satisfactorily as the traffic delivered to them in other months, it would be necessary for them to provide extensive additional facilities which would not be utilized a third of the time, and to hire a very large amount of additional labor. In order to make sure that they would have enough labor to handle the traffic expeditiously during the rush months it would be necessary for them to keep the additional labor on their pay-rolls twelve months in the year. It is because the roads do not now do this that they are always confronted with a shortage of engineers, trainmen and other employees, as well as of physical facilities when the rush months of traffic come.

If the additional facilities and labor were provided the year around the fixed charges and operating expenses of the railways would be very heavily increased, and the public would have to pay these additional fixed charges and operating expenses in the form of higher rates. Clearly recognizing this fact, does the public desire the railways to provide the additional facilities and labor? It does not. It may say that it does, but if actions speak louder than words it does not. The railway managers of the country repeatedly, year after year, have told the public that with existing rates they could not provide sufficient facilities and labor to handle the rush months traffic expeditiously; and the public throughout this period has consistently refused to permit the railways to meet increasing expenses and fixed charges by higher rates. Our newspaper friends may continue to grow cynical and caustic if they like when railway men renew the cry of car shortage; but they can rest assured that, regardless of their comments, that cry will continue to be heard in the land with increasing frequency just as long as the present policy of chronically legislating to increase railway expenses and curtail railway earnings is persevered in. The job of making bricks without straw is still just as impossible as it ever was.

Fortunately, while the main remedy for car shortages is larger railway earnings in proportion to railway expenses, the condition can be partially remedied by a more efficient use of existing facilities. More thorough study and supervision of the handling of cars and trains will reduce the delays to cars while they are in the hands of the railways. Better co-operation between the railways and their patrons in order to reduce the delays to cars while shippers and consignees have them for loading and unloading will further ameliorate the situation. The railway managements should do all that they can to increase the efficiency with which locomotives and cars are used. The patrons of the railways should likewise do their part; and when newspaper writers criticise the railway managements for calling the attention of shippers to the situation and asking for their co-operation they show that they are either unfair, or ignorant of the conditions to be dealt with.

It often seems to be assumed that car shortages are peculiar to the United States. Some people advocate the development of inland waterways as a remedy for them; others, government ownership of railways. It is a salient fact that in Germany, where the development of inland waterways and government acquisition of railways have been carried out more consistently and thoroughly than in any other country, there are more complaints about shortages of freight cars than in any other country. The car shortage in the Ruhr district of Prussia rose in December, 1912, to 12,000 cars a day. This being 3 per cent. of the total freight cars in Prussia, it was equivalent to a shortage of 60,000 cars in the United States. Furthermore, it will be noted that this is only the shortage reported from a single industrial district of Prussia; and somewhat similar conditions existed throughout the country. Car shortages have been more numerous and larger in proportion and have lasted longer in Germany, with its state railways and its highly developed inland waterways, than in the United States; and the only remedies for them there, in the

United States or elsewhere, are, first, to provide the means for developing railway facilities in a reasonable ratio to the development of freight traffic; and, secondly, for both shippers and railways to so use the facilities available as to enable the largest practicable ton mileage to be moved with them.

#### GRADE CROSSINGS AND AUTOMOBILES.

THE question of safety at highway grade crossings is always present with every railroad manager, and since the advent of the automobile it is more intense than ever; and one of the worst afflicted roads is the Long Island, because of its peculiar situation. Its territory is level, and the building of mushroom railways was in former years as much of a craze there as on any western prairie; and those roads, some of them unnecessary, are now parts of the Long Island in good and regular standing, but with hundreds of level crossings. The territory is close to New York City and now largely within the city limits, and is very thickly populated. Automobiles by the hundreds are flying everywhere at all hours of the day and night. There have been many fatal accidents, followed by much public discussion. The Long Island road spends a large percentage of its earnings for crossing watchmen—at one time it was 5 per cent. of the gross receipts—and yet the unwatched crossings are numerous.

As to the general question of gates, flagmen and bells, and the problem of separating grades, our readers are well-informed, and we bring up this crossing question at this time, not to go over that familiar ground, but to discuss briefly that aspect of the case produced by the advent of the automobile; and we quote below a letter, abridged, recently sent to the *New York Times* by a committee of the City Club. This club is composed of some of New York's most public spirited citizens, and its utterances deserve consideration. The letter makes large demands, but it is evidently the product of one who is thoughtful and who believes that he is entirely reasonable. The letter says:

In their anxiety to escape all blame for the fatal automobile accident of Sunday the officials of the Long Island Railroad Company show that they still fail to recognize the new responsibilities which the automobile has placed upon them at grade crossings. It is not fair to place all the blame on the drivers. New conditions have arisen which it is up to the railroad to meet.

In the days of horse-drawn vehicles the fixed signs at country grade crossings were generally sufficient; the majority of persons were familiar with the locality, and whistles and bells could be heard in sufficient time. Present-day conditions are very different. The automobile is here, with its faster speed, requiring more distance in which to stop. . . . Again, automobilists do not confine their riding to one limited district, and cannot be expected to be familiar with the exact location of every crossing. . . . While some persons undoubtedly cross railroad tracks knowingly at unsafe speeds, it is unreasonable to expect thousands of drivers to run at a horse's pace on account of the possibility of coming unexpectedly upon a grade crossing. If railroads run their trains at full speed across highways it is only fair that they should give adequate warning and to change the warning to meet changed conditions.

The railroad companies alone can warn the motor car driver, and they must adopt a way to do it which will give a car sufficient time and distance in which to stop. The whistle is a noise to be given up. The Long Island should consider the use of searchlights, such as are commonly found on interurban electric cars.

If reliance is to be placed on an electric crossing bell, then additional bells should be placed on each side of the crossing, at a sufficient distance to allow easy stopping, like a distant signal on a railroad. A flagman is no longer sufficient; nor are gates sufficient, unless they are very conspicuous from a distance by day and night.

For the home signal at a crossing, a red sign with the word "Stop" would appear a good thing. For the distant signal, a yellow sign with the words "Slow down" might be enough. Gates might be painted with black and white stripes, like German signal posts.

The first thing that a railroad man notices about this letter is the calm assumption that the whole cost of any change should be borne by the railroads. So fully assured is the writer that that is the correct view that he does not even mention the possibility that a fair apportionment of the cost might throw a large share of it on the automobilist, or on the city. Possibly he

thinks that there would not be much expense. But any really effective arrangement which would permit people on the highway to approach railroads at 40 miles an hour, taking no care to look both ways for trains, would surely add materially to the cost of crossing maintenance. Railroads have not been able to avoid heavy cost in making such preparations at crossings of one railroad with another, and it is not likely that they can here; the highway is a good deal like a railroad when its users indulge in railroad speeds.

Indeed, the problem of letting fast moving vehicles cross one another's paths has always been one of the most troublesome that railroad men have to deal with; and this new problem is very much like the old one. One fundamental principle applies everywhere: the higher the speed the greater the expense and the care demanded. Except where money can be freely spent, speed must be severely limited. And an almost universal principle is that the newcomer who calls for a crossing must bear the whole, or a very large share, of the cost. A new railroad laying tracks across an old one cannot impose at will the cost of making or maintaining a crossing on the existing line. This is an accepted rule in railroad practice generally. Wherein is a new line of automobiles different, in this matter, from a new line of rail cars? The fact that a thousand automobiles are owned by a thousand different men does not alter the situation, so far as the railroad company is concerned. The only pretext for saddling the whole expense of this newly demanded safeguard on the railroad is the old one—might makes right. Cities and states have got into the habit of ordering the railroad to pay for everything but, logically, there is no reason why the automobile should not bear the whole of any additional expense or burden necessary to make crossings safe for them.

Concretely, the letter which we have quoted demands just one thing—distant signals on the highway. Powerful electric lights on trains would be in some degree useful, but we do not believe that this feature of the letter calls for serious attention. The general introduction of such lights would be costly, without providing a complete remedy. In some situations the light rays would not give a good warning; powerful lights are in some degree objectionable in themselves, as is often evident when one meets an automobile at night; and the absence or failure of a light would give a false sense of security. Every train not having a searchlight would have to reduce speed. The proposal for a distant signal on the highway is the only practical feature of the letter.

If automobiles are to be free everywhere to run at unlimited speeds distant signals are a necessity. Cities and towns may even find it necessary to erect distant warnings at curves in the highways, at narrow bridges and street corners. The intoxicated and the reckless chauffeur constitute the main difficulty; but a good deal of regulation has got to be administered to persons who class themselves as well-meaning, before our streets and roads will be reasonably safe. The railroads have no reason to consider themselves sinners above all the men that dwell in Jerusalem.

But the distant signal problem is not quite so simple as it seems. A target or sign fixed 500 ft. to 1000 ft. back from the tracks would be all right if it could be made surely visible at night; but visibility is a question of degree. Even in daylight a sign would have to be very big, very bright and very near the roadway not to be ignored by some drivers. Persons who have been struck by trains and subsequently have testified in court, frequently manifest the most astonishing blindness; and juries believe them. And, remembering the great range of country traversed by each automobile owner, uniformity in the design of these signs is an important desideratum; uniformity in size, color, location and wording. Uniform legislation in all the States might be found desirable and even necessary.

If automobile drivers would exercise even a moderate degree

of caution, a distant signal would be valuable without artificial light at night. It could be made visible at night except in such thick darkness as would impel any reasonable driver to limit himself to low speed; but the public will demand all possible protection, and we may as well consider a lamp as an essential. This makes a caretaker necessary; and as the railroads everywhere bear the burden of watching crossings, if anybody watches them, this burden will fall on them. Attending to two lamps several hundred feet from the crossing is a matter quite different from caring for a single lamp at the crossing. Should the watchman leave his post to relight a lamp that had gone out? Assuming that lamps would fail no oftener than signal lamps, or than crossing bells, the danger from failure would be small, and the problem of care may perhaps not be so serious as we have assumed; but it is well to bear in mind that lamp failures introduce a peculiar danger. Railroad men know this, from experience with block signals, but other people usually ignore the point, and they should be informed. At crossings where there is no attendant the question of care is, of course, more troublesome; the introduction of distant signals would add materially to the cost, for the work of the inspector would be increased and lamps, except where electric lights were available, would have to be regularly lighted and cleaned.

A signal distant from the tracks is not an absolute necessity. Drivers could reasonably be required to take the responsibility of discerning the warning before reaching it, especially if an audible signal were also provided. This would be possible except in time of fog or snowstorms; and at such times high speed on the highway ought to be prohibited. Ingenious arrangements of moving signals, and electric light effects which simulate moving lights, are already in use to a limited extent.

And the limitation of speeds in fog serves as a reminder that limitation is not only possible, but reasonable, at all times. We have discussed the distant signal, because the demand for it is not entirely unreasonable; there are places, no doubt, where it would facilitate traffic without much increase of expense and without enhancement of danger. But why should not the automobilist, for his own benefit, and his own peace of mind, run slowly at all places except where he can see a clear road? To assume that there is no crossing (or other danger) unless he sees it is to act like a blind man. To run at high speed when he has the affirmative testimony of his own eyes, that the roadway for a long distance ahead is clear and unobstructed may be proper—if he is not infringing the rights of other automobiles—but in any other condition he has no reasonable right to run otherwise than under control. Only by the introduction of the block system, like the block system of the railroads, can such practice fairly be tolerated.

In view of the conditions touched upon, and of other considerations which the reader will call to mind, we are inclined therefore to look with a very friendly eye on the proposal for a positive speed reducer at crossings which was noticed in our issue of August 15, page 302. Making a sharp turn in the road will compel everybody to run at moderate speed. There would be no injustice in this. The railroads have to have arbitrary speed limits. In the absence of adequate interlocked signals all trains at crossings and junctions are required by very rigid rules to run at low speed, and usually to stop. The distant signal idea has merit, even with the speed limiting angle in the road; and it may be that we ought to have both. A distant signal can serve to warn all who wish to be warned; but there will still be the reckless drivers to be reckoned with.

It is proper to add a word concerning automatic signals—apparatus which produces sights or sounds by means of electrical impulses started and stopped by the passage of trains. When properly actuated these indicate the approach of a train; their silence or absence indicates that none is approaching. Automatic bells at crossings are common, and visual signals, controlled in the same way, are in use to a limited extent.

These bells and signs are highly useful in their field, but they should never be used at any considerable distance from a crossing, for the reason that when they give the wrong indication because of being out of order they introduce an element of danger. This danger is a feature to be reckoned with. With the signal at the crossings it is sufficiently small to be tolerable; the signals are valuable in spite of it; but at a point 500 ft. away, a signal indicating to the motorist "proceed" when it ought to indicate "stop," would be very definitely dangerous because he would feel warranted in putting on full speed. There are other reasons why a signal fixed at a distance from a crossing should never encourage a driver to increase his speed, but this one alone is controlling.

#### AMERICAN LOCOMOTIVE COMPANY.

THE annual report of the American Locomotive Company for the year ended June 30, 1913, shows that the earnings of that company increased in proportion to the very large increase in locomotive construction during that period compared with the previous year. In the calendar year 1912 the number of locomotives ordered was larger than in any other year since 1906 and until June, 1913, orders continued to come in at approximately the same rate. It is not surprising, therefore, that the gross revenue of the American Locomotive Company for the year, \$54,868,175, including earnings from the manufacture of automobiles, was the largest of any year in the history of the company. It was \$24,418,723 larger than in 1912; \$5,350,000 larger than in 1907, the best previous year, and over twice as great as in 1902, the first year in the company's history. The interest earned on the common stock was 17.7 per cent. compared to 0.47 per cent. in 1912 and 18 per cent. in 1907. No dividends have been paid on the common stock since 1907. The company started the year under the most auspicious conditions, for on June 30, 1912, the contract work in course of construction amounted to \$2,051,187, compared with \$740,550 one year before; also the amount of unfilled orders on July 1, 1912, was \$14,450,000, compared with \$6,015,000 on the corresponding date of the previous year. Judging from present indications the earnings of the fiscal year 1914 will show a decrease from those of last year, for, although the contract work in course of construction on June 30, 1913, amounted to \$3,975,022, and the amount of unfilled orders on the following day was \$17,156,388, orders have shown a sharp falling off since last May, so much so that it is expected that there will be a reduction in the operations of the plants in the United States in the near future.

The manufacturing, maintenance and administrative expenses, including a charge of \$1,226,535 for depreciation, were \$48,041,691, an increase of \$19,924,144 over 1912, during which the depreciation charge amounted to \$1,021,382. The profit available for dividends was \$6,185,305, which was exceeded only in 1907, when it amounted to \$6,358,207; for the year 1912 the profit available for dividends was \$2,331,904. In 1913, after the payment of the 7 per cent. preferred dividend, there was set aside \$600,000 out of the remaining surplus of \$4,435,305, to provide for current additions and betterments to the plants. In 1912 nothing was set aside for those purposes. On June 30, 1912, the reserve fund for additions and betterments was \$416,023. During 1913, \$1,113,329 was spent on additions and betterments, of which \$513,535 was charged to the additions and betterment fund, and \$599,794, to capital account. On June 30, 1913, the reserve for additions and betterments was \$502,488. The surplus in 1912 was \$117,554. In 1907 the surplus after paying the preferred dividend was \$4,608,207, out of which was paid the last dividend on the \$25,000,000 common stock, which amounted to \$1,250,000, or 5 per cent. The net credit to profit and loss in 1913 was \$3,835,305, compared with \$117,554 in the previous year and \$1,358,207 in 1907, during which year \$2,000,000 was credited to the additions and betterment fund.

During June, 1913, \$55,000 of the second installment of \$2,000,000 short term notes, due October 1, 1913, were redeemed. The balance of this issue will be paid at maturity. In January, \$1,200,000 of the authorized issue of \$6,000,000 5 per cent. notes dated July 1, 1912, were sold. After October 1, 1913, there will be \$6,800,000 notes outstanding which will mature as follows: \$2,000,000 on October 1, 1914; \$1,600,000 on July 1, 1915; \$1,600,000 on July 1, 1916; and \$1,600,000 on July 1, 1917.

Although the company had on hand at the end of the year a relatively small amount of cash—a little over \$1,500,000—and expects to pay off in cash nearly \$2,000,000 notes on October 1, it is understood that there will not in all probability be any need for a renewal of notes or for any extensive borrowing on short term paper. There were at the end of the year \$13,326,000 accounts collectible and nearly \$1,000,000 bills receivable. Since the greater part of the American Locomotive Company accounts and the paper accepted are for 30 days, these accounts have been falling due more rapidly since June 30 than has the necessary extension of the company's own credit to meet the requirements of new business. It is expected, therefore, that there will be no difficulty in permanently retiring the October 1 notes and still having sufficient cash to meet current requirements. Total current liabilities on June 30 amounted to \$13,726,383, which included \$8,745,000 notes, of which the October 1 maturities are a part, and \$4,464,169 accounts payable.

The report of President W. H. Marshall is in part as follows: "With a view to keeping pace with the constantly growing market in Canada, which for some time has been more than the Montreal plant could meet, there was authorized an expenditure of \$550,000 for extensions to that plant which, when completed about January, 1914, will increase its capacity to 35 engines per month, or about 40 per cent.

"The board of directors at a meeting held August 13, 1913, resolved to discontinue the manufacture of automobiles and motor trucks. The automobile department, since its start in 1905, has been unprofitable to the company and the prospect for the future of carrying on the business successfully is so uncertain as not to warrant, in the judgment of the directors, a continuance in this field of industry. Out of the accumulated surplus of the company, a reserve of \$2,300,000 has been created to meet any losses that may occur in the liquidation of this business.

"The company takes this opportunity to assure the owners of Alco vehicles that arrangements will be made to furnish them with repair parts for a period of not less than five years to come and, further, that it will fulfill in every respect its obligations given under guarantee to its customers.

"The annual physical inventory of materials and supplies was taken at the close of the year, and priced at cost, unless such cost was above the market value on June 30, 1913, in which case the market price was used.

"The balance sheet includes a charge of \$702,378, representing equipment trust notes discounted by this company in advance of maturity, and, as there is a possible obligation, in the event of any default in payment, a like amount is also shown as a contingent liability. The notes are secured by a lien upon the locomotives, and the security is ample. There has been a decrease in this amount since last year of \$827,189."

The convertible assets and current liabilities on June 30, 1913, and June 30, 1912, were as follows:

CONVERTIBLE ASSETS.		
	1913.	1912.
Cash .....	\$1,562,474	\$4,375,540
Accounts collectible .....	13,326,031	9,924,566
Notes receivable .....	996,239	777,592
Accrued interest .....	1,770	13,123
Material and supplies .....	5,749,234	5,688,823
Contract work in course of construction .....	3,975,022	2,051,187
Industrial locomotives and automobiles manufactured for stock .....	1,298,256	952,621
Total .....	\$26,909,026	\$23,783,454

CURRENT LIABILITIES.

	1913.	1912.
Coupon notes .....	\$8,745,000	\$8,600,000
Loans payable .....	.....	1,500,000
Accounts payable .....	4,464,169	4,503,233
Accrued interest .....	79,479	92,876
Unclaimed interest .....	235	450
Dividends on preferred stock payable July 21, 1912 .....	437,500	437,500
Total .....	\$13,726,383	\$15,134,059

NEW BOOKS.

*The Universal Directory of Railway Officials*, 1913. Compiled under the direction of S. Richardson Blundstone. Published by the Directory Publishing Co., 15 Farringdon avenue, E.C., London, England. Price 10 shillings.

The nineteenth edition of this directory of railroad officers, which is compiled from official sources under the direction of the editor of the *Railway Engineer* (London), includes not only the principal steam railroads in the United Kingdom, Europe, Asia, Africa, North and South America and Mexico, but also includes tramways and electric railways in the United Kingdom. While, of course, space permits of giving the name and address only of the higher officers in each department of the railway, the compilation is the most comprehensive in its field of anything that we know of and should be of great use in the general offices of railway supply houses having some foreign clientele. The work of compilation is done very carefully and the addresses are given in the language of the country, so that if copied on a letter exactly as found in the directory, should prevent the return of letters through the dead letter office. The first section of the book is arranged alphabetically by countries and the second section alphabetically by persons.

*Sayings and Writings About the Railways*. Paper bound; 4 1/4 in. x 6 1/4 in.; 240 pages. Published by the *Railway Age Gazette*. Distributed by the McGraw-Hill Book Company, 239 W. 39th street, New York. Price, 25 cents each, with special price for large quantities.

If a person interested in American railway problems during the past few years had carefully preserved and indexed every instructive utterance of the principal railroad presidents, financiers and governmental authorities on the subject indicated; and also of the most noted scholars, students, statesmen and investigators of the subject, as published day by day in the newspapers and magazines, he would deem himself the possessor of a valuable treasury of facts. This task has been done for him by the author of this little book; and the mass of matter, really varied, rich and comprehensive, is condensed into a small but thick pamphlet which can be carried in the pocket.

The character of the matter included is indicated by the sub-heads: What Railroads Have Done and What They Mean to Civilization and Prosperity; Who Owns the Railways? Efficiency and Safety; Taxation; Wages and Labor; Some of the Present Needs; "What the Traffic Will Bear"; Rates and Rate Making; Regulation and Legislation; Capital and Credit; Government Ownership and Valuation; Railways and Canals. There are about two hundred quotations, nearly all of them quite short; and the list of names of authors includes apparently nearly every railroad president who has expressed his views in public. Of authors other than railroad officers the following is a partial list, which will indicate the great extent of the field covered: William M. Acworth, Henry C. Adams, Joseph G. Cannon, William J. Cunningham, James O. Fagan, A. T. Hadley, H. S. Haines, Charles E. Hughes, Emory R. Johnson, Martin A. Knapp, H. T. Newcomb, Neville Priestly, Logan G. McPherson, Theodore Roosevelt, Simon Sterne, William H. Taft and Woodrow Wilson.

The compiler of this aggregation is frankly "pro-railroad," and an anti-railroad agitator would call him prejudiced; but the material furnished is so voluminous and is the product of such strong minds that no reader will lack food for thought on all sides of the railroad problem.

Letters to the Editor.

A WELL-QUALIFIED CRITIC.

NEW YORK, August 20, 1913.

TO THE EDITOR OF THE RAILWAY AGE GAZETTE:

I have read with interest a number of articles referring to the fact that the managements of railroads are actually hiring people to criticize what is wrong in the administration of their properties from a public point of view.

It strikes me that the principle is very good, but that the expenditure of money for that purpose is needless. Railroad men are part of the public, but they travel more than most other people. They travel mostly on passes.

It seems to me the least thing a railroad man can do, in consideration of free transportation, is to write to the management of the railroad company over which he happens to travel and tell them whatever he may have noticed which is worth criticizing. I have practised this golden rule for a number of years and have received some letters which show that my criticism was greatly appreciated.

F. J. LISMAN.

CAR MOVEMENT AND INTERCHANGE.

NEW YORK, August 16, 1913.

TO THE EDITOR OF THE RAILWAY AGE GAZETTE:

In trying to give more movement to freight cars opportunities for improvement will often be found at points of interchange. This is because the responsibility for the facilities and operation at interchange points is largely divided between the two railroads concerned. They must agree before interchange tracks are provided at all; each road is careful not to get the worst of the deal; and undue economy of one road may result in lack of needed facilities by both.

Again, proper operation at an interchange point means co-operation, and where this is lacking delays to cars are inevitable, especially where co-operation is replaced by rivalry. It is good, of course, when a superintendent points out with pride that "he has never been blocked at X by the Y. & Z. railway," but it is bad when he is equally proud of being able "to block the Y. & Z. at X whenever he wants to," although it is a very rational piece of human nature.

Sometimes when an interchange point is blocked it is very difficult to find out why it was blocked, and thus guard against repetition. The yardmasters of the two roads will differ radically, and it is very hard to make them co-operate for the future, to say nothing of analyzing the past. To prevent such difficulties the manager will require fuller car reports from points of interchange than from other points, and will see that these reports are checked periodically against the reports of the connecting lines, so that the yardmasters of both roads will work on a common basis.

A full report from an interchange point would show at the reporting hour—say midnight—in each direction, (1) the cars moved from the interchange track in the past 24 hours, (2) the cars on the interchange track, and (3) the cars in yard and not moved to the track. It is not meant that all these items should be sent by wire from every interchange point daily, but every yardmaster should record these facts daily, after checking them with his neighbor, and should be prepared to report them upon the least sign of congestion. It is often desirable to have item 3 reported regularly from the larger points. This figure shows cars for interchange which have not reached interchange tracks for one reason or another. If it grows large it indicates trouble. If it grows larger than the daily movement it is the basis of an expensive per diem reclaim, sign of a more expensive delay.

If this figure is kept low it indicates that facilities are ample and interchange is prompt.

ARTHUR HALE,

General Agent, American Railway Association.

### A CLAIM OF THE COMMISSION.

FORT WORTH, Texas, July 24, 1913.

TO THE EDITOR OF THE RAILWAY AGE GAZETTE:

In the twenty-sixth annual report of the Interstate Commerce Commission, on page 60, the following statement is made:

One result already apparent from the operation of the hours of service law is that the number of train miles run for each trainman employed has considerably increased since the law became effective. This increase is especially significant in view of the fact that for a number of years previous to 1908 there was a steady decrease in this item.

It may be supposed that the commission compiled figures and that this statement is justified, but many men in positions to know believe the facts are directly contrary.

So far as I can learn the mileage of the individual train or engineman has decreased since the hours of service law went into effect. The law restricted their runs, cut down long divisions, prevented doubling back into home terminals, tied them up at intermediate points, and reduced their earnings, increased the number of crews and also increased their expenses when tied up.

A great number of train and enginemen complained of reduced wages, of having to move their homes and change runs. It is true that since 1908 the rate of pay has increased and that the hours of service law was used as one reason for asking increases; also it is true that labor agitators supported it like full crew bills to increase the number of men and standardize or rather equalize wages and do away with preferred runs.

On many western roads when business fluctuated prior to 1908 during rushes, freight crews often made nearly as much in one month as they do now in two months with increased rates. Another cause that reduces mileage is the necessity of greater efficiency by reason of increased costs, bigger trains are hauled and speed reduced, freight train tonnage in many cases has been doubled.

On first class roads the number of hours per trip has frequently decreased, but not by reason of this law. Mr. Fox, general manager of the Atchison, Topeka & Santa Fe, says:

The number of hours per trip have decreased. The principal reason for this is the additional facilities, such as passing tracks, yards, grade reduction, handling business currently instead of having it congested as was the case from 1903 to 1908, and ability of our motive power to handle its rating and consequently trains being on time and the loss of time in meeting and passing is practically eliminated.

Shorter hours are due to better efficiency of the plant and not to the law.

Mr. Fox prepared a statement, which I attach, showing mileage made by eight conductors in service full month in 1906 compared with same information for 1912, which indicates 30,563 miles less made by the crews in 1912 than was made in 1906. The overtime in 1912 was 1½ per cent. of their total pay roll earning, while the overtime in 1906 for the same service was approximately 11 per cent. of the roll.

These eight conductors worked on the western division where the conditions were about the same in 1912 as in 1906. On the Colorado division overtime in 1906 was 12½ per cent., in 1913 it is about 4 per cent.

On the New Mexico division in December, 1906, the mileage was 3,635 miles per man, for 1912—3,512, but overtime in 1906 was 16½ per cent., while in December, 1912, it was only 7½ per cent., this being a mountain division. On the Rio Grande division conditions have materially changed, light engines and ordinary trains run in 1906 while heavy power used in 1906 with a big increase in tonnage. The average miles per man in 1906 was 2,761, in 1913, 2,623, which is about 13 miles less per man. Overtime in 1907 was 9 per cent., while in 1913 it averaged 6 per cent.

It is assumed that this statement is typical and fairly represents general conditions on most western railroads, and from it and general knowledge of other lines I feel sure the commission's conclusions are not warranted and were made because they looked well in print.

I do not intend to criticize the law, the railroads had to have it; but I believe the commission is not entitled to the claim made.

EVERY TURNER,

Receiver, St. Louis, San Francisco & Texas.  
WESTERN DIVISION.

Comparative statements of mileage made by eight conductors making highest mileage each month for the years 1906 and 1912.

Year.	Month.	Miles.	Year.	Month.	Miles.
1906	January	35,619	1912	January	33,188
1906	February	27,591	1912	February	24,229
1906	March	34,284	1912	March	33,313
1906	April	31,659	1912	April	30,115
1906	May	31,914	1912	May	21,477
1906	June	27,154	1912	June	21,222
1906	July	30,206	1912	July	24,984
1906	August	28,698	1912	August	28,098
1906	September	30,051	1912	September	29,599
1906	October	30,657	1912	October	32,176
1906	November	31,127	1912	November	29,576
1906	December	30,767	1912	December	31,187
Total		369,727	Total		339,164

A decrease of 30,563 miles.

### LOCOMOTIVE BOILER CIRCULATION.

BALTIMORE, Md., August 6, 1913.

TO THE EDITOR OF THE RAILWAY AGE GAZETTE:

I have read with interest the criticism by Walter D. Wood, published in your issue of August 1. While I was reading this letter, I could not help but see the last paragraph of Mr. Wood's letter on another subject, which read as follows: "Tradition and past performances are hard things to fight, and many an inventor has gone down to discouragement simply because he had something which others had tried and said couldn't be done." While I do not claim to be an inventor, and have had no feeling of discouragement as yet, I rather feel satisfied that the article on "Life of Fireboxes" will be a means of placing our designers on the alert, with a view of taking advantage of every opportunity towards increasing the life of fireboxes.

While in my article I did not claim that this circulation did represent truly the actual conditions, I did claim, and do maintain, that without exception it represents the direction of the circulation of the different shaped water legs, and I bear my argument out by the life of the different types obtained in service, also by the manner in which the silica, which was used in the test tubes to show the circulation more clearly, precipitated.

I have had considerable experience with sensitive pyrometers in locomotive test work taking firebox temperatures; they are very sensitive to any vibration, so much so, that I do not think sufficiently accurate results could be obtained so that any conclusion could be formed. A better means would be an adjustable try cock, which could be placed at various distances from the inside sheet; this would show how far from the sheet the steam bubbles force the water, but it would not be of any benefit as regards the outside sheet; and to use a pyrometer to obtain the direction of circulation near the outside sheet would not be practicable.

C. T. ROMMEL.

NEW STATION FOR ABERDEEN, SCOTLAND.—A contract for erecting a large new station at Aberdeen by the Caledonian Railway and the Great North of Scotland Railway has been awarded to P. & W. Anderson, of Glasgow; estimated cost, \$700,000. The station will be built principally of steel, with large sections of masonry and brickwork.

RAILWAY CONSTRUCTION IN RUSSIA.—The Russian government has consented to the construction of two new railway lines, the Odessa-Vilna and the Odessa-Zhlobin. The latter line was built as far as Zhlobin some years ago, but conditions then prevented its completion. It will be extended to join the main line of the Southwestern Railway, the work being done under supervision of the ministry of railways. The Odessa-Vilna line will be constructed by private capital to connect regions in the northwest with the Black sea.

# CONSTRUCTION OF NEW QUEBEC BRIDGE PIERS.

Methods Used in Sinking Very Large Caissons and Building Concrete and Granite Piers for St. Lawrence River Structure.

By H. P. BORDEN.\*

When the partially erected superstructure of the Quebec bridge, located about seven miles above the city of Quebec, collapsed in 1907, very little damage was done to the piers. One of the first questions taken up by the Board of Engineers appointed by the Dominion government to redesign and construct this bridge was whether the old masonry could be used for the new bridge. After a considerable number of preliminary designs had been worked out it was found that to construct a bridge that would be safe under all possible conditions, the structure should be made wider than the old, and that the weight of the steel would have to be very materially increased.

As the pressure on the foundations of the old piers was designed to be practically nine tons per square foot, which was considered sufficiently high, and as there seemed to be no satisfactory means of reinforcing or enlarging the piers, it was

It was found that the north and south abutments could be used without any radical changes. A series of borings was taken, from which it was learned that rock under the site of the new north main pier could be reached at a depth of about 70 ft., and on the south side about 86 ft. below the river bottom. The foundations of both anchor piers were well above high water mark, and rock was reached with very little excavation. The designs for the masonry, as finally approved, contained the following quantities of masonry;

North abutment (alterations).....	375 cu. yds.
North intermediate pier.....	1,666 cu. yds.
North anchor pier.....	17,736 cu. yds.
North main pier.....	31,860 cu. yds.
South main pier.....	38,269 cu. yds.
South anchor pier.....	16,128 cu. yds.
South abutment (alterations).....	26 cu. yds.

Total .....106,060 cu. yds.

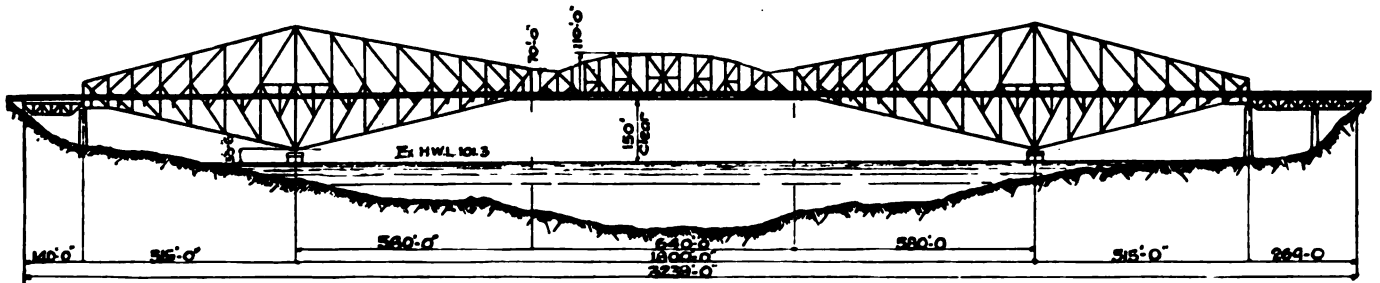

Elevation of New Quebec Bridge.

necessary to take down the old masonry and construct entirely new piers. As the tracks of the Transcontinental Railway had, at a very heavy expense, been brought up to the abutments of the old bridge, it was decided to maintain the old center line. The new piers were, therefore, designed to go just south of the existing piers, the north main pier being 65 ft. farther out into the river and the south main pier the same distance in shore, thus preserving the original length of the center span, 1,700 ft. The only important difference, therefore, in the layout of the masonry is that the approach spans between the abutments and anchor piers are of unequal length, and on the north side this requires an intermediate pier.

\*Assistant to Chief Engineer, Board of Engineers, Quebec Bridge, Montreal, Que.

## NORTH MAIN PIER.

Work was started on the sinking of the caisson for the north main pier in the spring of 1909. This caisson was a huge structure 180 ft. long and 55 ft. wide built of 12 in. x 12 in. long leaf southern pine. The caisson was built on launchways about three miles from the bridge site and launched and floated into position without any difficulty. After about 2,000 yds. of concrete had been deposited in this caisson, and it was about ready to ground on the bottom, an accident happened to the pumping machinery, and before it could be repaired the caisson had filled with water and had settled on an uneven bottom, seriously straining the structure and opening up the joints to such an extent that air could not be kept in the working chamber. It was decided to



General View of Plant on South Shore.



General View of North Side Showing Main and Anchor Piers and Abutment.



take out the masonry already deposited and to float it into dry dock and have the necessary repairs made.

As the sinking conditions were much more difficult on the north shore than on the south, it was decided to construct new caissons in two sections for the north pier and use the old caisson for the south main pier. Two new caissons were started immediately, each 85 ft. x 60 ft. They were constructed and floated in the spring of 1910 and sunk in position outside the old pier, being situated 10 ft. apart. The work of sinking these caissons progressed satisfactorily all season. The material encountered was very difficult, being a mass of boulders with only sufficient sand and gravel to fill the interstices. The rate of sinking of the west caisson was 0.37 ft. per day, and of the east 0.47 ft. per day. It was the original intention to sink these caissons to rock, but as the work progressed the sinking became more difficult and finally when the caissons had reached a position 20 ft. above rock, it was considered that the foundations at this point were quite satisfactory for many times the load that the piers would be called upon to carry. Tests were made of the bearing quality of this foundation and it was found that it sustained 60 tons per sq. ft., with practically no settle-

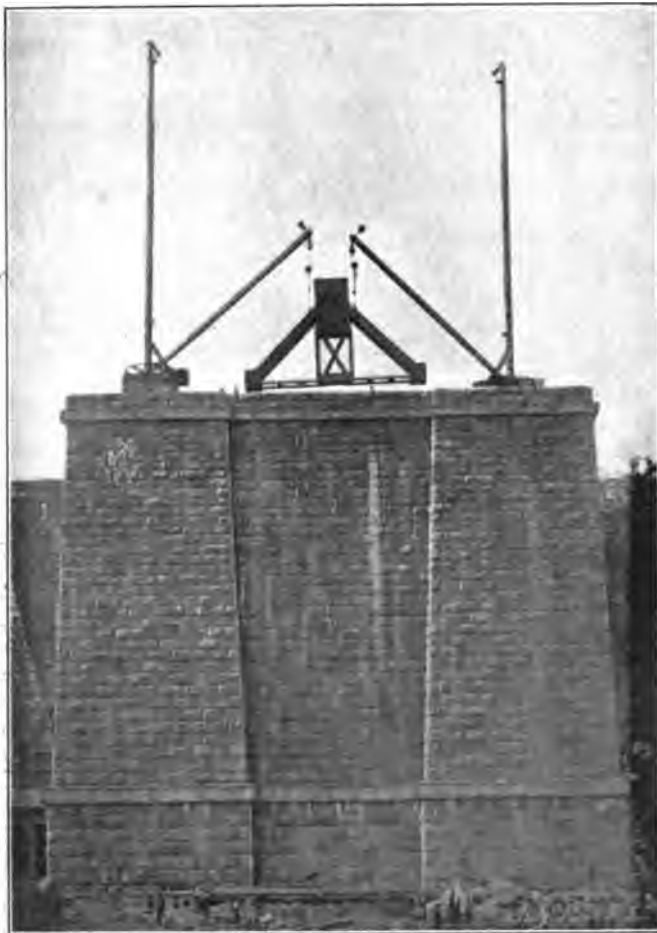

North Anchor Pier Showing the Wind Anchorage Steel.

ment. As the working load was only 8 tons per sq. ft. operations were stopped at this point, which was about 45 ft. below the bed of the river and 80 ft. below high tide. The working chamber was then sealed up, after which a thin grout was forced, by compressed air, down all the air pipes and shafts in order that all the interstices might be thoroughly filled. The space between the two caissons was then excavated with a clam shell bucket until all the loose material had been removed and this space was filled with concrete, flush with the top of the two caissons. The pier shaft was then started on this foundation

and the work was continued up to a point above high water.

As this pier is located about 500 ft. from the shore and is practically surrounded by water at all stages of the tide, a heavy platform was built around all sides of the caisson with two long trestles leading to the shore. On the platforms around the pier were located six stiff leg derricks with 75 ft. booms and 15 ton capacity which were used in handling stone, concrete, and also removing buckets of material through the service shafts in the caisson. Double tracks led down from the shore to the pier over the two trestles, on which were transported the stone from the cliff above and the concrete from the mixers situated at the foot of the

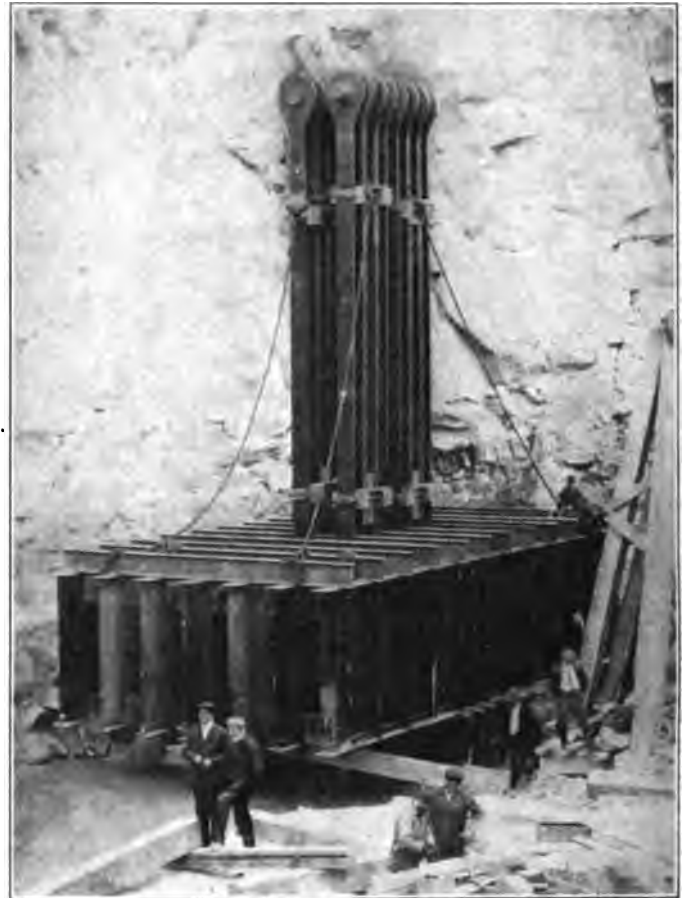

Setting Anchorage Steel In South Anchor Pier.

cliff. All the principal materials and supplies were received by rail and teams on top of this cliff, which is about 160 ft. above high water level, and delivered by gravity to the concrete plant and service tracks on the pier.

An elevator inclined about 45 deg. transported the heavier material between the two levels. Stone and sand was dumped into chutes from cars at the top of the cliff and led to the crusher plant and concrete mixers below. Coal was led to the boiler plant in the same way. Cement was brought down an inclined railway on balanced cars to the storehouse along the mixing platform.

At the start air was supplied by four 24 in. x 30 in. Ingersoll-Sargent air compressors discharging into a 12 in. main which acted as a reservoir and supplied the caissons through three 7 in. branches each with a gate valve outside the caisson. Later on this capacity was found to be insufficient for emergencies, and about 50 per cent. more the capacity was added. The compressors were operated by 600 h. p. horizontal boilers, which was increased about 30 per cent. before the work was finished. At the present time this pier is completed with the exception of the last few courses of masonry.

**NORTH ANCHOR AND INTERMEDIATE PIERS.**

The north anchor pier was 137 ft. long by 28 ft. 6 in. wide at the base, and 128 ft. 6 in. long and 20 ft. wide at the top. Below the ground line it was constructed of solid concrete, and above the ground line the facing is of granite with concrete backing. The pier itself is 156 ft. high. The courses range from 4 ft. at the bottom to 2 ft. at the top. This pier was finished this month. During last July the work on this pier proceeded at the rate of one course per day, including the time required to change the derricks. The work of changing these derricks, which operation is necessary every third day, has been reduced to a minimum. In the two anchorage wells in these piers the contractor has constructed wooden false work in sections. Each section is about 6 ft. high. Two guy derricks are raised on this false work which handles the stone for the facing of the pier. When it is necessary to lift the derricks an "A" frame gantry is hoisted on to the top of the masonry, which after being placed lifts the derrick mast about 6 ft., the guys being slacked as the mast is lifted. Another 6 ft. section of the false work is then placed under the derrick mast, which is then lowered in place and the guys tightened. This operation is carried out for both derricks before 7 o'clock in the morning. The operation takes from three to four hours each time. The work

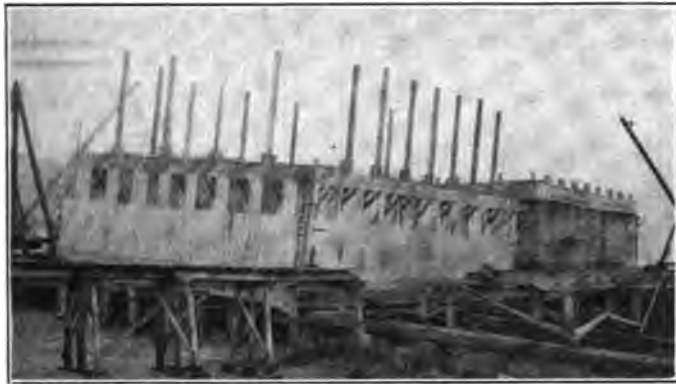

**Caissons Ready for Launching.**

therefore of laying the stone is not interfered with at all by the operation of shifting derricks.

The intermediate pier on the north side was a very simple piece of construction, the pier itself being 61 ft. 6 in. long, 14 ft. wide and 63 ft. 9 in. high, built of granite facing and concrete backing. This work has been finished.

**SOUTH MAIN AND ANCHOR PIERS.**

On the south side of the river the large caisson originally intended for the north side was used for the south main pier. As the river bottom is exposed at this point at low water an absolutely level bed could be secured. After this caisson had been thoroughly repaired in dry dock it was towed to the site and placed accurately in position without any difficulty. The sinking of this caisson was started and finished last season. The material encountered was of a very different nature from that on the north shore. At this point fine sand with a small quantity of boulders was met practically throughout the entire depth. The work progressed very much more rapidly, and an average penetration of 0.75 ft. per day was maintained during the entire period. This caisson was carried down to bed rock some 86 ft. below the bed of the river and 101 ft. below high water. The caisson was divided into 18 compartments; each compartment was supplied with a water jet at 100 lbs. pressure, which was used to loosen the sand and gravel. Each chamber was also provided with a 6 in. blow pipe through which a very large proportion of the material was removed by means of compressed air.

Both the north and south caissons were supplied with electric lights, so that the work could be performed at all times under the very best conditions. This caisson was fitted with three material shafts and four 3 ft. ladder shafts with air locks at top and bottom. The main ladder shaft, however, was fitted with a 6 ft. horizontal steel cylinder about 30 ft. long, located just above the deck of the working chamber and was built permanently into the concrete. This cylinder was large enough to hold the entire shift of "sand hogs" during the process of going in and coming



**Service and Ladder Shafts of Caisson at North Main Pier.**

out of the caisson, thus effecting a considerable saving of time and in air consumption. Owing to the fact that this caisson had received a certain amount of unknown damage at its first sinking, the greatest care was taken to prevent any further damage taking place. For this reason special appliances were devised for relieving the cutting edge from carrying all the load, and, by the use of sand jacks, the weight of the caisson was distributed over the entire bottom area. The manner of using these sand jacks was one of the most interesting features con-



**General View of Boiler Compressor, and Mixer Plant on North Side.**

ected with the sinking of this caisson and merits special description.

The jacks themselves were of very simple construction. The cylinders of the sand jacks had an internal diameter of 31 in., and were 36 in. long, constructed of ¼ in. steel plate with 4 in. lap joint; two angles 1½ in. x 1½ in. x ¼ in. reinforced the cylinder at top and bottom. The piston was a block of yellow pine 2 ft. 6 in. square and 5 ft. long. Four feet at one end was

round with a diameter of 29 in., thereby allowing 1 in. play in the cylinder. The lower end of the piston was reinforced by a 2½ in. x ¾ in. welded iron band. During operation the piston was attached rigidly to the roof of the working chamber by long screw bolts, and remained there permanently during the entire period of sinking.

In preparing for a drop, the first step was to excavate a hole under the piston. The cylinder was filled about two-thirds full of sand and placed in position under the piston and blocked up hard against it by means of timbers. While this was being done the caisson was supported on timber blocking under the bulkheads and other points. At the bottom of the sand jack was a 2 in. iron pipe extending entirely across the cylinder, the center

bags filled. Each cylinder contained in the neighborhood of 16 bags of sand, and this operation was continued until the cylinder was entirely emptied. By adopting the signal system and emptying the sand into bags, it was possible to guarantee that the whole caisson was being sunk at a uniform rate, and that there was no reasonable possibility of any part of the caisson being strained by being sunk more rapidly than another portion. As a rule a drop of from 18 in. to 2 ft. could be effected at each

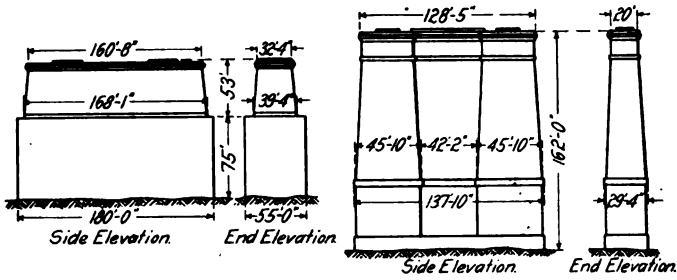

South Main Pier and North Anchor Pier.

of which was split and opened up to allow the sand to escape. This type had no bottom to the cylinder, the timbers acting as a support for the sand. Another type used had a steel bottom and two 3 in. holes with sliding cover at each side at the foot of the cylinder. The operation in both cases was the same.

When everything was ready for a drop, the timber blocking supporting the caisson was undermined by a water jet and the full load taken by the sand jacks. A man was stationed at every jack, and at a given signal, afforded by the flashing of the electric lights, each man turned a hydraulic jet with 60 lbs. pressure into the hole at the bottom of the cylinder, thus washing the sand out. The sand was caught in canvas bags of uniform size. When the canvas bag was full the lights flashed again and the water jet was turned off. Another bag was then obtained, and at the signal the jet was again turned on and the

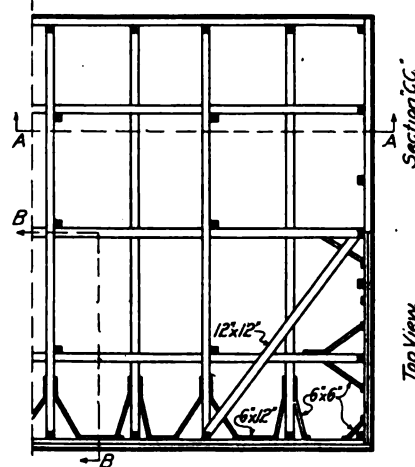
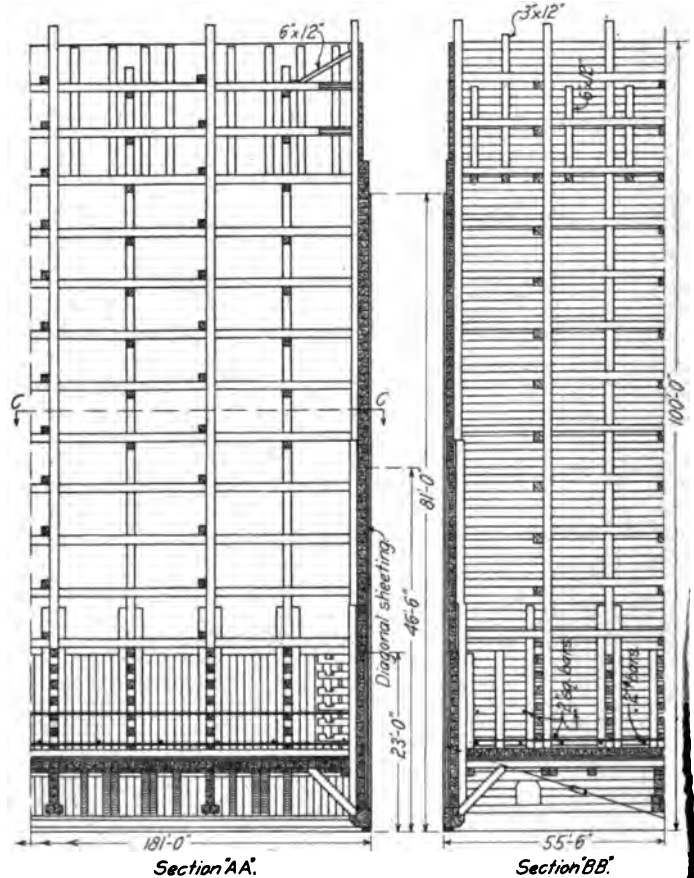

Details of Large Cofferdam Used for Main Piers.



Laying Masonry in Caisson of North Main Pier.

operation, the recurrence of the operations depending entirely on the nature of the material to be removed. When the drop had been finished the blocking was again placed under the bulkheads to take the load off the caisson, and the holes under the sand jacks deepened in order that the operation might be repeated.

The plant for sinking this caisson was approximately the same as that for the north side, only of considerably greater capacity. The rock used in the concrete was quarried from the top of cliff and carried by chutes to the crusher below. Sand, cer

gravel and coal were also brought by gravity to the lower level from the railroad tracks leading in above. Two 1½ yd. concrete mixers supplied the concrete which was taken in cars from the mixers to the loading platforms by gravity, the empty cars being drawn back by horses. The caisson stopped at elevation 1.31, the material being cleaned away about 2 ft. lower. The concrete was carried up to elevation 75.0, at which point the masonry shaft starts. The pier proper has a facing of granite blocks with backing of concrete, the last nine courses of both north and south main piers being solid granite.

Every facility for the men was supplied by the contractor. A steel hospital tank and hospital quarters were within a few yards of the caisson with a doctor continually in attendance. Shower baths, coffee rooms and boarding houses were constructed right on the site.

The south anchor pier has the same dimensions as the north anchor pier, except that this foundation does not go quite so deep. Work was started this year and is being pushed ahead during the present season.

Every effort is being put forth by the contractor to have this entire contract completed before winter sets in, in order to make way for the contractor for the superstructure, who is now on the ground.

The bridge is being built under the direction of C. N. Monsarrat, chairman and chief engineer, C. C. Schneider and Ralph Modjeski, members of the board of engineers, and John D. Wilkens, resident engineer. M. P. & J. T. Davis, Montreal and Quebec, are the contractors for the substructure. S. H. Woodward is chief engineer for the contractors.

### MASTER BLACKSMITHS' ASSOCIATION.

The twenty-first annual convention of the International Railroad Master Blacksmiths' Association, which was held in Richmond, Va., last week, as noted in our issue of August 22, page 346, was well attended and a number of important papers were read. W. H. Owens, master mechanic, Southern Railway, Manchester, Va., was present at the meeting on Wednesday and gave a short address.

#### FLUE WELDING.

E. J. Hoskins read a paper on this subject in which he stated that at the Lake Shore & Michigan Southern shops at Elkhart, Ind., five men in the blacksmith shop weld from 6,000 to 8,000 flues per month. In the erecting shop at this point the pits are so short that large superheater flues cannot be removed from the boilers without opening the erecting shop doors. To avoid cooling the shop in winter and to provide a special platform for applying superheater elements and the large tubes, there have been designed special cars that fit into the door opening. These serve the purpose of a door and also provide a convenient platform for the workmen in removing or applying superheater units and tubes.

Fred B. Nielson, Oregon Short Line, Pocatello, Idaho, stated that he considered it of more importance to swedge the flues than to weld them.

At the Ludlow, Ky., shops of the C. N. O. & T. P. there have been repaired 625 superheater flues from January 1, 1913, to June 1, 1913. A 2½-in. roller machine has been so converted that it can be changed in 20 minutes to weld 4½-in. or 5½-in. safe ends on superheater flues, by changing the mandrel and using the same rolls that are used for welding 2 in. or 2½ in. flues.

#### TOOLS AND FORMERS.

There was considerable divergence of opinion among the members regarding the use of tools in the smith shop. Some of those present considered that it was very easy to waste money in the making of tools and stated that they did not make tools for any job unless there were a large number of pieces to be made. Others stated that they believed there were very few jobs of any importance for which it did not pay to make special tools.

#### ELECTRIC WELDING.

Joseph Grine, New York Central & Hudson River, Depew, N. Y., read a paper from which the following is an extract:

"In connection with many others, our first experience with electric welding was very disappointing and failures were so many that at one time we came pretty nearly giving up the process entirely. With the discovery of an error in the adjustment of our machines, and its correction, marked improvements in results were obtained at once. We have two electric welding outfits, which have been operated day and night since May, 1912. At one of our shops 102 broken locomotive frames located in all varieties of places and on all sizes of power have been welded, and so far without a single failure; we believe it the easiest and cheapest method of welding frames without removal from the locomotive. There is no expansion or contraction to contend with in making such welds, and after completion the frame is in its original position. There is also a minimum amount of stripping needed.

"In frame welding the machines are adjusted to work at 147 amperes and 60 volts. The frames are prepared for welding in a similar manner to that for welding over a fire. They are "V'd" out by means of the oxy-acetylene machine, the oxidized surface left by the burner being then chipped off by an air hammer and chisel so that a clean surface is presented for the electric welder.

"The following is the total cost of welding frames of three different dimensions:

Frame 5 in. x 5½ in.	
Labor .....	\$5.63
Material .....	3.38
Total .....	\$9.01
Frame 4 in. by 4½ in.	
Labor .....	\$4.01
Material .....	2.51
Total .....	\$6.52
Frame 4 in. x 2½ in.	
Labor .....	\$3.03
Material .....	1.95
Total .....	\$4.98

"This includes the oxygen used to prepare the flame, wire necessary for welding, as well as the cost of the current used.

"Another item of saving effected by the process during the past winter is the filling up of flat spots on 46 locomotive driving wheel tires, these spots running in length from 2½ in. to 4½ in. It would, of course, have been necessary to turn these tires had it not been for the electric welder."

#### DROP FORGING.

G. F. Hinkens, Westinghouse Air Brake Company, gave it as his opinion that the secret of drop forging is in making the dies, and the secret of the die is in making the preparatory part so as to get the stock in the right place before placing it in the finishing die. There is a great deal of skill required by the die maker. He does not think that the ordinary machinist, until he has the experience, can make a die for a drop forging from a blue print or from a model unless he is instructed by somebody who knows how the die ought to be made. The next important thing is the hardening of the die. Drop forging dies are very expensive, and the cost of the work depends on the number of forgings that can be made.

At the Pennsylvania shops at Altoona, Pa., there is in use a 12,000-lb. steam drop hammer which is producing forgings weighing from 100 to 300 lbs. The dies for this hammer have to be well heat-treated. A hydraulic trimming press with a capacity of 200 tons is used.

#### SPRING MAKING AND REPAIRING.

In a committee report, G. M. Stewart, Pennsylvania Railroad, Altoona, Pa., said that with the use of machinery and a pyrometer it is possible to turn out much more accurate spring work than by hand. The report continued: "There has been installed in one of the Pennsylvania shops a machine for making springs which has proven a success, not one failure having been found in the making and adjusting of 2,000 plates recently turned out.

This machine shapes the plates properly, the pyrometer being used to get the correct temper, and all the plates being exact duplicates. It also shows a saving of not less than 30 per cent. in the cost of production. I may be somewhat premature in saying that elliptical springs will sooner or later be made by machinery, and without the use of a hammer, but in a number of shops this method is now in every-day operation and has resulted in a decided saving and a better spring. An objection may be raised to the machine method on account of the large number of designs of springs generally made or repaired in railroad shops. To induce the designing engineer to change designs will take time. However, if it can be shown that a superior spring can be made at lower cost, the question of providing the proper machinery will at least receive careful attention, and we may also hope to see a number of springs eliminated which differ only slightly.

"A number of methods of manufacturing elliptical springs by machinery are now employed. All that I am familiar with do this work in a hydraulic press or a bulldozer. Two methods of bending the leaves have been called to my attention. By one of these a number of fingers set close together like piano keys are employed; these are set to the desired radius by cams or by bolting each finger separately. When these are set the working surface looks like a piano keyboard bent to the shape of a spring. When forming the spring plate it is pressed between two of these keyboards, or one keyboard and a second set of weighted fingers, where each finger has a separate weight. The hot leaf is placed on the keyboard and is forced against the weighted fingers, raising each according to the camber. This method looks promising, especially where a large number of designs are required. Another method employed is to use dies, or dies and easily-made liners, for each radius of spring leaf. This requires a number of die liners, but when once made they will last for an indefinite number of leaves. By this method the leaf is pressed while hot between two dies, either in a hydraulic press or bulldozer. Either method will make elliptical spring leaves more uniformly than by hand setting.

"For the large elliptical springs, such as are used on locomotives and cars, the taper put on the leaves is rarely correct, and if properly made it should only extend back from the end about one inch. As a matter of fact the leaves are tapered back two or three inches, and as a result the taper of one leaf extends over the taper of the leaf above, so that the object of tapering is not obtained. Some railways have done away with tapering spring leaves, which is a step in the right direction. In some cases the leaf is square at the ends as it leaves the shear when cut from the bar, and in other cases the corners are clipped off, making the end of the leaf look like a spear with the point cut off. Either method makes a good looking spring, and saves the cost of heating the ends for rolling the points. I believe that the tapering machine could be put on the scrap heap, as has been done in one shop that I know of. Omitting the tapering of the leaves makes it much easier to form by dies, as it is difficult to make dies to fit the tapered ends.

"There is a method of manufacturing elliptical springs in which a hydraulic press is used. This is a double or two-story press; that is, one press above the other, each controlled by three rams of 25 tons' capacity each; by suitable valves 25, 50 or 75 tons' pressure may be used, according to the size of the leaf. In the bottom part of the press the end corners of the leaves are clipped off and the nib formed at the center; in the upper half the leaf is formed to the proper radius or camber. Following the leaf through, the process is as follows: The leaves are cut to the proper length, placed in the furnace, and the ends are then cut and the nibs formed in the lower part of the press. Next, the leaf is formed to the proper camber in the upper part of the press, the third and fourth operations being made with the one heat. It is then allowed to cool, and next is heated to 1,500 deg. F. and quenched in oil; it is then heated to 800 deg. F. and allowed to cool in air.

"In every-day practice two men can easily cut, nib and form

600 leaves in a ten-hour day. To change from one length of leaf to another takes about 15 minutes; to change from one kind of spring to another takes from 15 to 30 minutes.

"Probably no piece of steel is hardened by a much worse method than the locomotive spring. No blacksmith would think of hardening a lathe tool in the crude method used in hardening springs, yet with the heavy equipment of today, the spring must stand much abuse."

#### PIECE WORK.

Geo. P. White (M. K. & T.) :—Piece work enables a foreman to estimate the cost of work and the length of time necessary to do such work within a very small margin, for the workmen are after the money and know that it depends upon what kind of a day's work they put out, as to the amount of wages they will draw. For instance, we have 500 of a certain class of car to build. Knowing that our material is in stock and we have the drawings to work to, our first step would be to get out the forgings for the bottom, then the bodies and trucks. A foreman in a piece work shop should be able to tell within a day as to when certain forgings will be received for this work, as he knows the cost that he has to pay for each item, and would also know the amount that each workman would try to make. If it should come about for some reason that the company wanted this work several days ahead of the specified time, it is a very easy matter to push the work somewhat faster in a piece work shop than in a day work shop, for when the workmen see they are to benefit their pocketbooks, they will make every effort to get just a little more out each day.

J. H. Dalton (Erie Railroad, Huntington, Ind.) :—We work piece work on new and repair work. Wherever there is piece work the output is greater and that is what we are looking for. Some say under the piece work system they get an inferior grade of work, but I don't think so. If a man does a job which will not pass inspection, send it back to him and let him do it over on his own time and he will soon begin to do his work right. Under the piece work system the foreman has got more time to look after his other duties, because if a man gets out of a job he will hunt up the foreman instead of the foreman having to watch him. He will also take better care of his tools and have them ready for the next job.

C. E. Lewis (Penna., Baltimore, Md.) :—I have had about 29 years' experience with piece work, and think it is the only fair way to have work done. When the piece work system was first started at the Baltimore shops, there was a great deal of prejudice against it. The men seemed to think it was only another way of getting more work out of them, but they soon found that there was an advantage in it for them; and now if you ask a man to work day work he will become dissatisfied at once. I believe that all work should be done piece work. One of the worst things to contend with is that the prices are not set right at the beginning. If you get the price right at first, you will not have much trouble. When you set the price on a job of piece work be fair to the men as well as to the company.

#### OTHER BUSINESS.

There was some discussion on the subjects of case hardening, frame making and repairing, and the heat treatment of metals, and several illustrated papers on shop kinks, etc., were presented. There were also individual papers on "Cast Steel in the Blacksmith Shop" and "Efficiency" by George F. Hinkens.

The following officers were elected for the ensuing year: H. E. Gamble, Pennsylvania Railroad, Altoona, Pa., president; T. F. Buckley, Delaware, Lackawanna & Western, Scranton, Pa., first vice-president and T. E. Williams, Chicago & North Western, Chicago, Ill., second vice-president. The executive committee is composed of J. P. Sullivan, chairman; T. F. Keane, Fred Norris, J. F. Keller and F. F. Hoefle. The executive committee was instructed to choose from Denver, Milwaukee and Buffalo for the place for next year's convention. The report of the secretary showed that there are 244 active members, 25 associate and 8 honorary.

# INCREASING FREIGHT CAR EFFICIENCY.

Delays to Equipment in Yards, Their Causes, and Means  
Being Used on the Chicago & Alton for Remedying Them.

By B. A. WORTHINGTON,  
President, Chicago & Alton Railroad.

Under ordinary conditions the transportation of freight is the principal source of revenue to a railroad company, and all the machinery at its command is put in operation for this one principal purpose. Except on a very few roads passenger traffic is a secondary consideration and unremunerative; all other sources of revenue are merely incidental. Maintenance, solicitation, operation—in fact all the energies of a railroad organization—converge upon this one point, the movement of freight traffic; and the efficiency with which this is accomplished is the most important factor in determining the net results of operation.

In dealing with car efficiency, these fundamental principles are seldom mentioned, inasmuch as they are fundamental and are therefore always taken for granted; but in reviewing the situation, it is well that we should fix firmly in our minds how car efficiency bears upon the general scheme of railroading, and that it is simply a refinement in the application of elementary principles. It is a course in physical culture for a railroad—a “training-down” process—as no railroad can hope to produce its best results loaded down with a dead weight of superfluous equipment which, instead of performing a natural and healthy function, merely saps financial strength.

Arthur Hale, in his article “Getting More Movement for Freight Cars,” which appeared in the *Railway Age Gazette* for August 1, deals with the subject in a masterful manner; there is not much left to be said.

However, owing to the peculiar conditions governing the operations of the Chicago & Alton Railroad, we have classified car delays under two general heads, namely: In trains between terminals; and, in terminals and at stations.

The density and the character of the traffic on the Alton, together with the operating disadvantages resulting from train delays, are incentives enough to those in direct charge of train movements, to avoid delays, and this works to the advantage of car movement while cars are in trains between terminals.

But when it comes to yard movement these incentives are in a measure lost, and it is here that we have found a heavy drag upon the operations of the property. Therefore, to the elimination of delays in yards we have devoted our energies very diligently; and while we have found many discouraging and almost insurmountable obstacles opposing our efforts, we are satisfied that the impelling principles are correct, and that our efforts will finally be reflected in the net results of operation.

On the Alton, terminal delays have been classified as follows:

- (a) Those due to lack of adequate yard facilities.
- (b) Those due to lack of practical means to enforce economies.
- (c) Those due to bad order situation.
- (d) Disposition of foreign cars.
- (e) Unloading of commercial traffic.
- (f) Handling of company material.

(a) So far as yard facilities are concerned, our disabilities have long been recognized, but as improvement was possible only through expansion involving very large expenditures at all of our important terminals, the matter was postponed from year to year until further postponement could not be considered. At all of our principal terminals—Chicago, St. Louis, Kansas City, Springfield, Bloomington, Roodhouse, Slater—extensive improvements, aggregating in cost approximately \$1,500,000, have been arranged for, many of which will come into operation within the next month or two. With restricted yard facilities, the reduction of terminal delays on the Alton has been uphill work. Nevertheless, we have employed every available means to facilitate the movement of freight cars through yards. Switch engine mileage has been increased—as much as 39 per cent. in May, 1913—and many experiences practicable under our re-

stricted conditions have been employed. The results are beginning to show as may be noted from the following table:

	Average mileage per car per day—all cars.	
	1912.	1913.
January .....	19.21	21.71
February .....	19.92	21.44
March .....	23.03	23.23
April .....	18.85	25.33
May .....	19.97	25.07
June .....	22.69	24.48
July .....	23.17	25.61

(b) In congested yards where additional switching crews cannot be employed to advantage it is almost out of the question to consider any of the finer points of operation, in view of the pressing necessity for moving loaded cars without delay; whereas, with adequate facilities, a better classification and more orderly conduct of business are possible, with a smaller number of switching crews.

(c) One of our greatest difficulties has been due to the rapid increase in the number of bad order cars; and for some time past we have been specializing on this feature, believing that a car shortage will prevail this fall and winter, and realizing that every idle car represents so much unremunerative capital and lost traffic, and seriously impedes the conduct of business. To relieve the situation, the Alton has spent for freight car repairs during the fiscal year ended June 30, 1913, \$1,405,209. This is \$458,334 in excess of normal maintenance, and represents deferred maintenance charged out in operating expenses during the period stated. This is a part of a comprehensive plan to reduce the bad order situation on the Alton, an appropriation of \$1,715,157 having been made for maintenance of equipment (including all classes of equipment), substantially one-half of which was spent in the first year. We have sent to outside repair shops several hundred bad order cars requiring heavy repairs, and have also inaugurated a system for making light repairs to freight car equipment in yards, avoiding the necessity of switching to repair tracks. Clearing up the bad order situation on the Alton will be a great relief. It is like getting rid of a cancer.

(d) Owing to the fact that the Alton is an originating road with but a limited supply of system cars at its disposal, the handling of foreign equipment is a live question at all times. Necessarily, under these conditions, car balances stand against the Alton, and it is urgently necessary to handle foreign cars expeditiously in order to avoid excessive car hire charges. Therefore, all matters pertaining to such equipment are handled by wire. If a foreign car cannot be loaded home without delay, it is ordered home immediately, and an open record of each individual car is maintained in the car service department, each car being under constant surveillance until delivery is effected to the proper connection. The first lot of 2,900 new freight cars has been received, and it is expected that this new equipment will enable us to clear foreign cars more promptly.

(e) The handling of house, team-track and other cars in revenue service is checked up closely. Consignees are notified promptly by telephone upon the arrival of carload shipments, the usual postal notice following. Recently, in addition to the regular demurrage charges, we have inaugurated a charge of \$1 per day after the first forty-eight hours free time, and \$2 per day after the expiration of ninety-six hours, for team-track storage, this charge applying at all stations on the Alton road. In addition to the strict enforcement of demurrage and storage rules, direct personal appeal is made to shippers and consignees to impress upon them the mutual advantages in releasing cars promptly.

(f) The handling of company material is a cause of con-

siderable delay to cars, but this matter, likewise, is followed up closely. Copies of manifests covering shipments of company material handled by the stores department are sent by the first train to the car service department; tracers are sent out immediately with instructions to release cars promptly; and the matter is kept in open file and followed up closely until cars are released and returned to revenue service. Such reports show the time of arrival and the time of unloading, together with other information necessary, and delay in unloading after the arrival of a car at destination is promptly and definitely located. Assistant engineers, supervisors, trainmasters, etc., are required to give loading and unloading of company material their personal supervision. Each week the situation is rounded up and my office is furnished with a statement complete in detail, showing cars on hand under load of company material, date received, lading, to whom consigned, etc., and unusual detentions are taken up with heads of departments.

While it is our desire to restrict the handling of company material to system cars, foreign cars frequently get into this service, but as a rule they are released promptly. Delays to foreign cars appearing on the weekly "On-hand" reports are handled vigorously. In fact, the movement of all cars in company service is watched critically, on the theory that they are worth too much in revenue service to warrant any delay whatever in handling company materials.

Aside from these specific causes of delay, the less important details of car movement are constantly being checked up. For instance, a general check of yards is made daily by local forces and periodically by the car service department which is held strictly accountable for per diem balances. In the periodical checks made under the supervision of the car service department, the arrival records are checked against the outbound movement to ascertain the average detention in yards, which is used for comparative purposes, and the list of cars on hand is scrutinized critically. In our periodical checks, the feature watched most carefully is the handling of foreign cars to connections, unusual delays being rigidly investigated.

Trainmasters are also required to make periodical checks of yards. At each yard, bills for loaded and empty cars are stamped with the time of arrival, and the yardmaster is held personally responsible for checking these cards twice a day, with a view to avoiding unnecessary delay.

Repair tracks, also, are checked, not only by the car department, but also the car service department, the latter department receiving copies of all orders for material and undertaking to see that there is no delay in furnishing such material, in repairing the cars, and returning them to revenue service.

Bad order cars on the line are handled in the same manner, the car service department maintaining an open record and a close check upon individual cars until repairs are made and cars returned to service.

Inasmuch as directly or indirectly all the functions of a railroad organization are exercised in the interest of freight revenue, and as the equipment provided for freight traffic amounts to a very substantial part of the total capital investment in any railroad property, the activity of freight cars in service assumes a significant aspect; it is a reliable index to efficiency in the most important functions of a railroad; and, while on the Alton, we have been laboring under physical difficulties, the results attending our efforts are highly encouraging. With the improvements and added facilities now coming into service, we expect an improvement in average miles per car per day.

### WILLIAM P. CLOUGH.

William P. Clough is to be made chairman of the board of the Northern Pacific, on the resignation of Howard Elliott as president and the creation of this new office.

The creation of this office and the election of Mr. Clough to it are rather a concrete expression of the appreciation of the Northern Pacific directors for the responsibility and executive work which Mr. Clough has been doing for the past 12 years than any radical change in these duties.

William P. Clough was born in Cortland county, New York, and began railway work on October 1, 1880, as general counsel in the west for the Northern Pacific; occupying that position until June 1, 1887, when he entered the executive department of the St. Paul, Minneapolis & Manitoba as assistant to the president, soon after becoming a director and the second vice-president of that company.

February 1, 1890, when the St. Paul, Minneapolis & Manitoba was taken over by the Great Northern, he became a director and the first vice-president of the latter company, and remained in those positions until the summer of 1901, when he resigned them to become a director of the Chicago, Burlington & Quincy, and a director and a member of the executive committee of

the Northern Pacific, which positions he has continued to hold, and which, for the past twelve years, have chiefly occupied his time. On July 1, 1912, he became first vice-president of the Northern Pacific.

RAILWAY CONSTRUCTION IN JAPAN.—The Imperial Japanese Bureau of Railways announces that construction work on 39 lines will be carried out during the fiscal years ending March 31, 1914, and March 31, 1915, during which 285 miles and 169 miles, respectively, of new lines will be opened for traffic. The total railroad mileage to be completed in Kyushu is 94 miles. The important Miyazaki line to be extended 28 miles will open up a vast forest country, and its extension will give a great impetus to the timber industry in Kyushu. The Sendai line from Kagoshima to Kushikino is being built to serve the new large gold mine at Kushikino.

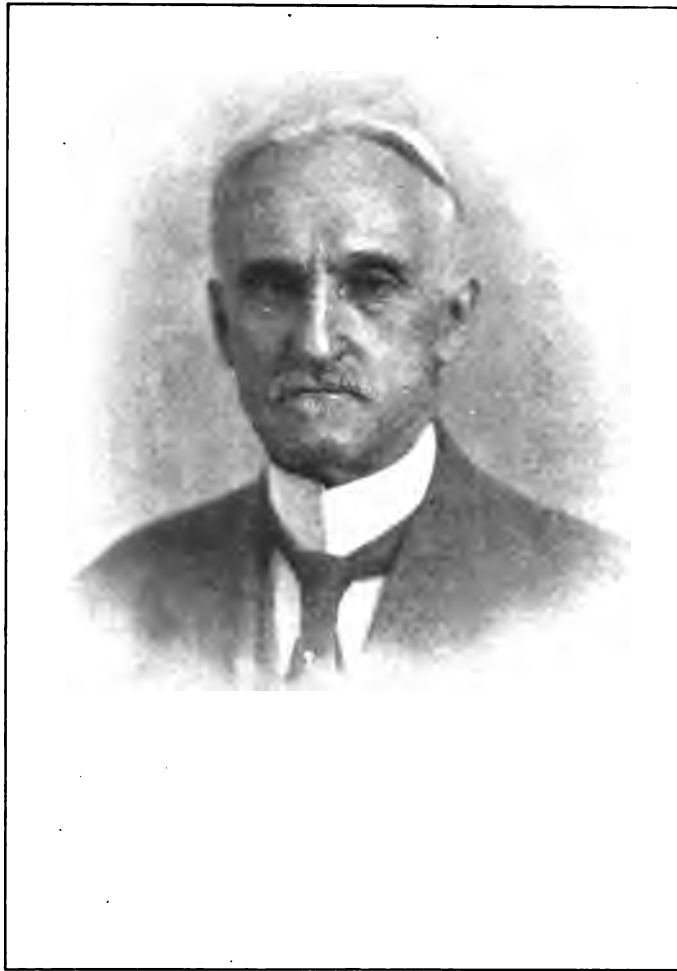

W. P. Clough.

## J. M. HANNAFORD.

Jule M. Hannaford, second vice-president of the Northern Pacific, has been recommended by the executive committee for election as president, to succeed Howard Elliott, as announced in a recent issue. The election of Mr. Hannaford will be a well deserved recognition of over 41 years of consecutive and faithful service on the Northern Pacific, since he became connected with the road in 1872 as chief clerk in the general freight office at St. Paul. For many years he has been reputed one of the ablest traffic officials in the country. It also represents another conspicuous example of the policy of promoting traffic men to railway presidencies, for Mr. Hannaford's entire railway experience has been in the traffic department, of which he has been in charge since 1899 successively as third vice-president and second vice-president, and previously as traffic manager.

His railway service was begun in 1866 as a clerk in the general freight office of the Central Vermont at St. Albans, Vt., where he remained until he went with the Northern Pacific in 1872. In his first position with the latter road he is said to have compiled and written with a pen the first regular distance tariff of freight rates ever published on the Northern Pacific, and the original now hangs in his office at St. Paul.

He is one of the most democratic and approachable of men, and his election as president will be especially acceptable to the shippers with whom he has been so long associated, and among whom he is exceptionally popular, as he bears an enviable reputation for willingness to hear both sides before reaching a decision and to co-operate with the patrons of the road for the best interests of all concerned. Mr. Hannaford is also remarkably popular with his subordinates and employees of the company, which is attributed not only to his kindly and pleasing personality, but also to the fact that he never forgets an old friend, and has in many ways been especially appreciative of loyal and faithful service on the part of his subordinates.

He was born November 19, 1850, at Claremont, N. H., and from June, 1866, to May 11, 1872, was clerk in the general freight office of the Vermont Central. On May 17, 1872, he became chief clerk in the general freight office of the Northern Pacific, and on May 1, 1879, was promoted to assistant general freight and passenger agent. From May 1, 1881, to August 1, 1883, he was general freight agent of the Eastern division, and from August 1, 1883, to March 1, 1884, assistant superintendent of freight traffic. He was then for two years general freight agent of the main line and branches, for four years traffic manager, and from 1890 to 1899, general traffic manager. From 1890 to 1893 he was also general traffic manager of the Wisconsin Central lines during their lease to the Northern Pacific.



J. M. Hannaford.

On February 1, 1899, he was elected third vice-president, and on April 1, 1902, second vice-president. From June 1, 1895, to June 28, 1906, he was also vice-president and general superintendent of the Northern Pacific Express Company, and since June 28, 1906, he has been president of that company.

## THE SAYINGS OF STUBBS.

Former Governor Stubbs of Kansas is making a tour of Europe. He is a very active creature, is Stubbs, and he seems to have gathered more misinformation than do most politicians on such a voyage. The rivers and canals of Germany fill him with delight, and he demands that Uncle Sam buy a similar set of hand-picked waterways at once.

"If the United States will develop its internal waterways system, even to a slight extent," writes Governor Stubbs, "the complaint of high freights will be no longer heard. . . . A New York to Chicago canal would pay for itself in five years."

The *Journal* believes that in this concept of a New York to Chicago canal, Mr. Stubbs has made a new record in absurdity. He has extended the limit. A magnificent natural waterway reaches from Chicago to Buffalo—two-thirds of the distance to New York. Why abandon the lakes for a canal? For the rest of the route, the old Erie ditch is being deepened and widened; but the people of the empire state will be satisfied if this undertaking pays for itself in fifty years instead of five.

The Hon. Stubbs speaks of waterways as a cure for high freight rates. Twenty minutes' research would show him that railroad freight rates in Germany are almost twice as high as those in the United States. The average rate in Germany is 13 mills per ton-mile; in America it is about 7.6 mills. Nor can this be explained by saying that in Germany cheap and bulky commodities are shipped by water. The entire freightage of all the rivers in

Germany for a year is less than the amount handled by the Pennsylvania Railroad system in two months.

If political journeymen would learn something about their own country before going abroad, they might be less ready to overwhelm the folks back home with advice—but such counsel as they did give would be better worth having.—*Chicago Daily Journal*.

PROPOSED SPANISH RAILWAY.—The project for the line from Pamplona to Logrono via Estella has been approved by the Ministerio de Fomento. The concession for construction is to be advertised in the near future and awarded this autumn so that work may begin early in the spring of 1914. Government engineers are examining the land necessary for the construction of a railway from Soria to Castejon.



# AMERICAN ASSOCIATION OF RAILROAD SUPERINTENDENTS.

## Car Efficiency and Train Movement, Interchange Rules and Handling of Explosives Discussed at Chicago Convention.

The twenty-second annual convention of the American Association of Railroad Superintendents was held at the Hotel Sherman, Chicago, on Thursday and Friday, August 21 and 22. President Charles Burlingame, superintendent of the Wiggins Ferry Company, St. Louis, presided.

The morning session was devoted to preliminary business in connection with the organization of the association, discussion of subjects to be referred to committees for report at next year's convention and the report of the executive committee. It was decided to refer to the committee on transportation the subjects of proper marking, packing and stowing of freight, and identification of men in train and yard service; to the committee on interchange car inspection the subject of uniform car lettering, and to the executive committee the subject of allowing time and expenses to men attending the convention of the Train Dispatchers' Association. The association last year referred to the American Railway Association a recommendation that that body recommend to the railways that train dispatchers be allowed time and expenses for this purpose, but it appeared that no action had been taken. J. F. Mackie, secretary-editor of the Train Dispatchers' Association, stated that several roads, including the Boston & Maine, New York, New Haven & Hartford, Atchison, Topeka & Santa Fe, Southern, Chesapeake & Ohio and Norfolk & Western, had allowed either time or expenses or both. The Boston & Maine had allowed the men \$5 a day for expenses, but had required them to take the time out of their vacations. The executive committee will follow up last year's recommendation.

The subject of overhead inspection of box cars was referred to the interchange committee for consideration during next year. There was a long discussion on the question of making general yardmasters eligible to membership in the association. President Burlingame said that the yardmasters have no association of their own and that they could offer very valuable suggestions, increasing the attendance at and interest in the meetings, and perhaps representing superintendents who could not attend themselves. It was decided to refer this subject to the executive committee for a report at next year's meeting.

### E. H. DEGROOT'S ADDRESS.

E. H. DeGroot, Jr., superintendent of transportation of the Chicago & Eastern Illinois, and past-president of the association, addressed the convention informally. He said that in order to increase the attendance at the conventions it was necessary that superior officers instruct the superintendents to attend as they are so burdened with details that they cannot get away from their work unless it is made part of their duty. The association has been passing through a critical period but he believed it has a brilliant future before it. The superintendents, with their experience and familiarity with the practical details of operation, are the men to solve the important and complex operating problems of the day. They must be interested in the work of the association, and the general managers must be interested sufficiently to instruct them to attend. Referring to the discussion on the overhead inspection of box cars, he said that any man who doubts the importance of the subject has only to walk through the cars in his local yards and observe their condition, and to note the loss and damage claims, to be convinced that it is one of the most important subjects the association could consider. Regarding the admission of general yardmasters, he thought it would be very fitting if either the general superintendent, superintendent or yardmaster might represent his company at the conventions. The question of rank or dignity should not be considered. The yardmasters are thoroughly conversant with many details of operation that can make or break the superintendent.

Mr. DeGroot urged the association to give most careful atten-

tion to the subject of obtaining greater efficiency in the use of freight cars. No one has more to do with car efficiency than the superintendent, but he is the hardest man to convince that his own car movement is not the best on earth. Cars make 25 to 26 miles per day on the average. The intermediate lines handling freight for long distances tend to bring up the average and originating a short haul lines tend to bring it down. The movement of cars in trains can hardly be greatly improved; increased efficiency must come in the handling at terminals. If cars on interchange track are "pulled" but once a day, cars are delayed, there is a delay in switching them to the repair track, the forwarding track or to an industry, and cars are also subject to delay awaiting movement or during their detention by consignees or shippers. If each superintendent can be convinced that his own cars are not moving fast enough much will have been done to avert car shortages and reduce car hire bills. There are some things that cannot be avoided, but frequently eight or nine days are consumed at local stations because proper arrangements are not made for preventing delays or if made are not carried out.

A vote of thanks was tendered Mr. DeGroot for his address.

Mr. Burlingame supplemented his remarks on car efficiency, saying that there is no economy in unduly reducing forces at terminals and that there are many incidental advantages in having adequate forces, such as the prevention of fires and theft, and reduction of per diem charges. The subject of improving movement of cars at terminals was referred to the transportation committee.

E. H. Harman, secretary and treasurer, reported that the membership had been increased from 74 last year to 159 as the result of a campaign to increase interest in the work of the association. A circular describing the objects of the association, and giving a copy of the constitution and by-laws and the printed proceedings had been sent to every operating official in North America, and an effort had been made to establish local divisions of the association at all important terminal points.

T. B. Fogg, general manager Toledo Terminal, presented the report of the executive committee, recommending the appointment of an auditing committee and an arbitration committee to arbitrate such cases as may be referred to it by the local divisions. The committee also recommended that the next convention be held during the latter part of May instead of in August. The association voted to adopt the recommendations providing for the new committees and to hold the convention on the third Thursday and Friday of May, the place of meeting to be decided by the executive committee. The executive committee will also take up with the general managers' associations the question of obtaining better recognition of the association so that superintendents may be instructed to attend the meetings. The committee was also instructed to make provision in the by-laws for honorary membership in the association to include past-presidents.

### ADDRESS BY COL. B. W. DUNN.

At the afternoon session Col. B. W. Dunn, chief inspector of the Bureau for the Safe Transportation of Explosives and Other Dangerous Articles, gave an informal talk on the handling of explosives, inflammables and acids, illustrated by a series of motion pictures which have just been made for the bureau with the assistance of the educational bureau of the Union Pacific, for the purpose of showing proper and improper methods. Col. Dunn explained that the pictures had been worked up as an experiment to take the place of or supplement the present lectures with stereopticon views which have been given by inspectors of the bureau before railway men all over the country. The motion picture film includes printed explanations of the various pictures

so that it may be used without a lecture, and includes views showing proper and improper methods of storing and loading explosives, the rejection of a box of high explosives by an agent on account of its leaky condition, the proper manner of inspecting packages and shipping orders, bracing a package in a car, the use of the various placards, labels and stamps required to be used on cars, packages and waybills, proper method of handling a leaky shipment of dynamite—placing it in a larger box and packing with sawdust—sending a telegram asking a bureau inspector to come and destroy the package, the methods followed by the inspector in destroying it, and the burning dynamite. One picture shows a freight handler trucking a leaky barrel of gasolene into a box car, lighting a cigarette while in the car, and the resulting explosion, the man being carried out dead. Another shows the proper method of bracing carboys of acids in a car, sprinkling ashes or sand around the base to absorb leakage.

The Union Pacific has provided its instruction car with a set of these pictures, and has been showing them to 30 to 40 men a day for the past month and it is proposed to have all roads maintaining such cars use them in the same way. The films shown will be used on the Illinois Central.

Col. Dunn described briefly the work of the bureau, showing that the loss and damage caused by accidents in the handling of explosives and similar articles had been reduced from \$500,000 in 1907 to about \$10,000 in 1912 and the number of lives lost from 50 to none. He appealed especially to the superintendents to cooperate with the work of the bureau by educating their employees and by following up the reports of inspectors in order to apply the necessary remedies. He said that the source of the greatest danger today is rough handling of cars containing dangerous articles, and that hardly a week passes that a report does not reach his office of contents of cars damaged by rough treatment. These reports are all referred to the general managers for investigation, but he has never yet received any other than that "on our line this car was handled with extreme care." The good record of last year is likely to go by the board at any time because of some accident caused by rough handling in spite of all the care that is being exercised generally. About 5,000 cars of dangerous articles are transported daily, and every time a package is broken there is great danger of a very serious disaster. He wanted to hear from the superintendents as to what could be done to prevent rough handling, and suggested that possibly a device could be perfected to be installed in cars that would record instances of severe shocks so that they could be located and discipline administered.

*Discussion.*—The address aroused a lively discussion of the subject of rough handling. Several superintendents thought that under present conditions it was impossible to obtain "softer" switching of cars, and that dependence for safe handling would have to be placed on the containers in which dangerous articles are packed. Several thought the expense of the additional precautions required in the handling of such articles should be borne to a greater extent by the shippers, as being out of proportion to the rates received. Col. Dunn explained that the double first class rates charged for such articles is greater than the revenue received from other articles to compensate for the additional expense of safeguarding their handling, the average cost of bracing being about \$2.06 per car, and that the manufacturers of explosives have shown a praiseworthy spirit of cooperation in making their packages safer. Several superintendents thought that a strong metal container and a cushion packing might obviate the necessity of such strict regulations as to the condition of cars, to which Col. Dunn replied that no packing would be safe in a car in a condition to admit sparks and set the car or its other contents on fire, and that there were many practical difficulties involved in the distribution of cushions.

M. Marea, general superintendent St. Louis, Troy & Eastern, expressed the opinion that explosives should not be stowed in the car ends, where there is danger of accident during repairing

of draft rigging, and thought that some kind of cushion might be devised to be placed between the load and the car end. J. M. Walsh, superintendent Illinois Central, said that the rules against allowing engines or cars to strike a train containing explosives should be more strictly enforced.

President Burlingame thought that explosives are given special handling in most large yards, as in the case of perishable articles, and that most of the rough handling is during the line haul. He did not see how the shocks of transportation could be materially reduced with the large cars, especially as, with automatic couplers the switchmen are not so careful as in the days of the link and pin. Mr. DeGroot emphasized Col. Dunn's remarks about the necessity of interesting the superintendent, saying that little improvement can be obtained unless the superintendent is convinced of its necessity, but that if he is interested he is in a position to exert a multiplicity of influence through his organization. The solution of the rough handling problem, he thought, is greater supervision.

It was decided to refer the subject to the committee on transportation for a report at the next meeting.

#### REVISION OF TRAIN RULES.

J. E. Scott, dispatcher of the Gulf, Colorado & Santa Fe at Cleburne, Tex., presented a report of the joint committee on train rules of the American Association of Railroad Superintendents and the Train Dispatchers' Association, which consisted of a number of amendments and additions to the joint report of recommendations and suggestions as to revising the Standard Code of Train Rules and Forms of orders previously approved by the two associations and submitted to the American Railway Association under date of February 20, 1913. The original report consisted of a pamphlet of 23 pages. The report as adopted after a lengthy and interesting discussion includes the following:

Rule 14. A new signal is added, 000—, flagman go forward and protect train. In a note the committee says: "There seems to be a necessity for a whistle signal of this kind, especially in automatic block territory. The signal we have suggested for this is 14 (c) reversed and we recommend the signal 00 00 instead of what we have heretofore recommended for 14 (q). We also suggest that a certain standard duration for long and short whistle signals, respectively, be prescribed, say 2 seconds for short, 4 seconds for long and 8 seconds for approaching stations, junctions, etc.

"We also suggest that railways generally be recommended to arrange with each other at intersecting points, whistle signals for calling in flagmen of a character similar to what we have recommended for intraroad points in 14 (d), (e), (f) and (g). It is our belief that a standard code satisfactory to the Interstate Commission—should such a code be made obligatory by law—would require such provision. We suggest that the junior line signal be given twice, with the briefest possible interval between the calls."

Rule 27. It is suggested that the rule be modified to require switch lights found extinguished to be relighted.

Rule 86B, first paragraph, is amended to read: "An inferior train must clear the time of a first class train or a passenger extra train, Form 'G,' Example (3), in the same direction, at the station where clearance is made, not less than 10 minutes, or must be clear of the main track by the time such first class or extra train is due to leave the last station in the rear where time is shown. Failing to clear the main track by the time required, it must be protected as prescribed by Rule 99. (See Rules 92 (A) and 87.)"

Rule 104. A paragraph is added as follows: "A switch must not be closed until the train taking the siding has fully cleared the fouling point."

Rule 201. "Being of the opinion that the person authorized to issue orders or instructions should be authorized to do so over his own signature, we suggest that train orders should be signed by the train dispatcher issuing them." Also add to first paragraph: "Instructions affecting trains, of other character than as illustrated in 'Forms of Orders' must not be issued on Train Order forms." "Note.—We suggest the 'Pink Bulletin,' as used on numerous lines, or some similar form, for the purpose of issuing other telegraph (or telephone) instructions." Second paragraph, Standard Code. It is suggested that this be changed to read: "They must be in the prescribed forms when applicable; and without erasure, alteration or interlineation. When not in a prescribed form, they must be brief and clear." "Note.—It seems evident that this injunction to be 'brief and clear' refers to forms created by the dispatcher, since the use of the prescribed forms when applicable leaves no discretion as to either brevity or clearness. We have found much confusion of thought to exist on this point."

Rule 204. The words requiring station operators to retain and preserve a copy of train orders are eliminated.

Rule 206 is amended to read: "Regular trains will be designated in train orders by their numbers as 'No. 1,' '2nd No. 1,' or 'Nos. 1 and 3,' adding

engine numbers if desired for identification. When more than one engine on a train, only one need be designated." "Note.—We are strongly impressed with the great desirability, in the interest of safety, of train identification signals. We know of several recent hazards caused by their absence."

Rules 210 and 211. Amended to require operator in listening to repetition of train order, to underscore his office copy, to increase assurance that he actually listens to the repetition as required.

Rule 221A and 221B. Insert. "When a train has been cleared and afterwards orders are issued to it, the original clearance card must be surrendered and a new one issued with the orders."

Rule 299. "New Rule. Insert immediately after 'Forms of Train Orders' striking out present paragraph: 'All of these forms and examples may be used in combination, with such changes in wording as conform to the principle involved. They may be used for two or more first or second designated trains, and for consecutive movements as illustrated by examples (2), 'form A.'"

An alternate Form F and rules to provide for yellow signals on first and intermediate sections and green signals on last sections, is amended to provide that no signals shall be used for one train on a schedule and that white signals shall be used for extra trains.

Wherever in the original report the 15 train order is specified the pink bulletin as suggested in Rule 201 is to be understood.

Many of these and other changes suggested were for the purpose of making the rules more specific in various technicalities to avoid misunderstandings that have sometimes developed in practice.

*Discussion.*—The discussion on the train rules report was continued at the morning session on Friday. Those present were greatly interested in the recommendation that train dispatchers should use their own signatures instead of those of the superintendents. Mr. Fogg said that this has been put into practice on his road. Mr. DeGroot said that it would be an important step in the development of the train dispatcher, and that if a man is given responsibility he should be given the necessary authority in black and white.

Considerable importance was also attached to the change in Rule 201, providing that incidental instructions affecting trains shall not be issued on train order forms. Mr. DeGroot described the system of pink bulletins used on the Chicago & Eastern Illinois, which are also used on the Rock Island, Pennsylvania and other roads. The chief participants in the discussion on train rules included J. F. Mackie, secretary-editor of the Train Dispatchers' Association, and J. P. Finan, dispatcher of the Atchison, Topeka & Santa Fe, at Needles, Cal.

#### INTERCHANGE CAR INSPECTION.

The following report of the committee on interchange car inspection was presented by M. Marea, chairman:

"After due deliberation, it is the general opinion on the subject of Visible Load Transfer, taking into consideration the modification of the American Railway Association Rule 15 so that the cost of transfer will not be charged against delivering company unless the physical defects cannot be repaired under load, that this association should submit to the American Railway Association the proposition of defining exactly what shall constitute a delivering line's liability.

"The St. Louis division of this association has defined that a combination of defects must exist before the delivering line shall be responsible for the transfer, for the reason that many receiving railroads say they have not the facilities to make certain repairs under load, while the delivering line may have the facilities.

"Under the present Master Car Builders' Rules an injustice is often done the line maintaining ample facilities for making repairs, because there is a chance to err as to who is liable for the transfer, when there is a difference in the repair facilities of the lines involved.

"Your committee wishes also to call attention to the following tabulated statement showing transfer claims handled in the first six months of 1911 under the twenty-four hour clause in the St.

Louis territory, as compared with similar claims handled the first six months 1913 under the combination clause:

#### TRANSFER CLAIMS HANDLED FIRST SIX MONTHS OF 1911 UNDER TWENTY-FOUR HOUR CLAUSE.

	Claims.	Cards.	Cuts.
January .....	1,109	820	289
February .....	966	599	367
March .....	1,144	698	446
April .....	897	680	217
May .....	1,310	1,146	164
June .....	1,373	1,204	169
Total .....	6,799	5,147	1,652

#### TRANSFER CLAIMS HANDLED FIRST SIX MONTHS OF 1913 UNDER COMBINATION CLAUSE.

	Claims.	Cards.	Cuts.
January .....	333	230	103
February .....	232	131	101
March .....	356	280	76
April .....	292	203	89
May .....	436	289	147
June .....	428	256	172
Total .....	2,077	1,389	688

"You can readily see the difference; it plainly shows that the twenty-four hour clause is a bad arrangement and that it will eventually breed discontent at any large interchange point.

"Your committee will not at this time make other recommendations in regards to interchange car inspection, owing to changes in the Master Car Builders' rules which go into effect September 1, 1913, and recent changes in Master Car Builders' rules 120 to 131 which went into effect August 1, 1913. The changes in these rules it is expected will bring a great benefit to all railroads, by facilitating the movement of cars unfit for lading to the home line. After the new rules have been in operation for a reasonable period your committee may have some further changes to recommend."

Minority reports were submitted by J. E. Mechling, master mechanic of the Vandalia and H. Boutet, chief interchange inspector of the Cincinnati Interchange Car Inspection Bureau.

*Discussion.*—After discussion a resolution was adopted recommending that the American Railway Association change Car Service Rule 15 to provide that the delivering line shall not be billed for the cost of transfer, except under a combination of defects as defined in the M. C. B. Rules. Several of those present were in favor of abolishing inspection except for safety, and including the cost of repairs except for owner's defects in the per diem charge. Mr. Burlingame said that the St. Louis lines had already recommended this on the ground that 14 cents of the per diem rate actually covers the cost of repairs.

At the concluding session on Friday afternoon W. W. Wheatley of New York presented a paper on "Railway Economics."

C. B. Schmidt, commissioner of immigration, Rock Island Lines, presented a paper on "Immigration and Western Development Work."

#### MR. SCHMIDT'S PAPER.

Mr. Schmidt traced the history of emigration from the earliest times, describing particularly the methods by which the first western railways created a population in their newly opened territory, and the changing character of immigration in recent years.

"An immigration official, to be successful," he said, "must familiarize himself, not only with the character, resources and opportunities of the territory to which immigration is to be directed, but also with the general economic conditions in all those parts of the world from which immigration may be drawn. He must be sufficiently intelligent and experienced to inspire the homeseeker with confidence in his judgment and integrity. Willful misrepresentation or faulty judgment in giving advice, will soon destroy his usefulness. And it is in this respect that the field officers of the railroad company, the general and division superintendents and their assistants can be of inestimable help to the immigration department. The operating department official has a constant opportunity to familiarize himself with the character of the lands and colonization opportunities along his division."

Mr. Schmidt opposed vigorously the present tendency in certain quarters to consider immigration a menace rather than a benefit, as a result of which restrictive legislation is constantly urged upon congress, chiefly in the pretended interest of organized labor. He declared that foreign labor does not reduce wage scales but stimulates industry and enables the native worker who despises menial labor to secure for himself higher employment at more remunerative wages.

"The time has not yet arrived," he added, "when we should exclude from our country the surplus human force—brain, brawn and muscle of old Europe, on flimsy pretexts, such, for instance, as the proposed literacy test, which fortunately was successfully vetoed by President Taft, but is now being brought forward again under the chaperonage of Senator Dillingham in a new guise. We are not getting at present a foreign immigration too large

## HEAVY POWER FOR THE NORTHERN PACIFIC.

The Northern Pacific has the distinction of employing a larger number of Mikado type locomotives than any other road in the country. The first order of this type consisted of 25 locomotives of which six were tandem compound were built by the American Locomotive Company in 1904. These were almost the pioneers of the type in this country, so far as modern heavy power is concerned, and are simple engines having 24 in. x 30 in. cylinders, 63 in. driving wheels, 200 lbs. steam pressure and have a total weight on drivers of 195,000 lbs. The tractive effort is 46,630 lbs. At that time these locomotives were the heaviest on that road and among the heaviest in the country. Since 1904 various improved designs have been developed from the original



Powerful Articulated Pusher Locomotive; Northern Pacific.

for the country to digest. If the Dillingham bill should become law, it would mean the exclusion annually of about 200,000 able bodied immigrants, who come to us to employ their muscle and brawn in hard labor to produce values. Railroad officials of all grades and in all departments should interest themselves in immigration and give to the immigration official all possible aid and to the immigrant—native or foreign, their sympathy. The railroad superintendent especially is in position to aid the immigration officials in their work of getting the homeseeker properly located."

The following officers were re-elected for the ensuing year: President, Charles Burlingame, superintendent Wiggins Ferry Company, St. Louis; vice-president, H. R. Saunders, terminal superintendent, Chicago, Rock Island & Pacific, Kansas City; secretary-treasurer, E. H. Harman, Terminal Railroad Association, St. Louis.

**NEW LINE FOR THE BALEARIC ISLANDS.**—The concession for a strategic railway from Palma to Santany, Balearic Islands, has been awarded to the Compania de Ferrocarriles de Mallorca, Mallorca, Balearic Islands, Spain.

engines until at present the Northern Pacific has in operation 470 locomotives of the 2-8-2 type built by the American Locomotive Company.

The latest addition to this equipment is 50 locomotives having 28 in. x 30 in. cylinders, 63 in. driving wheels, 180 lbs. steam pressure and a tractive effort of 57,400 lbs. The total weight on drivers is 240,500 lbs. While the first engines did not have combustion chambers, an order which followed shortly after was so provided, the design being prepared by David Van Alstyne, then superintendent of motive power. The various orders which have followed have in each case had a combustion chamber and the later engines also have superheaters.

As part of the latest order, the American Locomotive Company has also delivered ten Mallet locomotives of the 2-8-8-2 type, which are a development of the previous design of articulated locomotive that has been very successfully used in helper service on this road.

That the new locomotives are proving to be all that could be expected is evident from the following description of the work they are doing on various divisions.

They have been put into service between Mandan, N. D., and



Latest Development of the 2-8-2 Type Locomotive on the Northern Pacific.

Paradise, Mont., including the Yellowstone, Montana and Rocky Mountain divisions. The Yellowstone division, Mandan, N. D., to Billings, Mont., is 441 miles long and has a maximum grade of one per cent. against both east and westbound traffic. The new Mikado locomotives (Class W 3) are hauling 1,800 tons over this district at an average speed of from eight to ten miles an hour.

On the Montana division, Billings, Mont., to Helena, Mont., a distance of 239 miles, there is a ruling grade westbound from Livingston to Muir, twelve miles long, of 1.8 per cent., and eastbound from Bozeman to Muir, thirteen miles long, of 1.9 per cent.; all grades are compensated. West of Bozeman the maximum grade is 0.8 per cent. against eastbound traffic. In this territory the Mikados are hauling 1,800 tons with a Class Z-1 Mallet helper between Bozeman and Muir. The Class Z-1 Mallet is a 2-6-6-2 type, having cylinders 20 in. and 31 in. x 30 in., saturated steam, 210 lbs. pressure, weight on drivers of 262,350 lbs., and a tractive effort of 58,100 lbs.

Previous to receiving the new Mikados, trains of 1,400 tons were hauled over this territory by a Class W (2-8-2 type) locomotive using the same helper. The Class W has cylinders 24 in. x 30 in., saturated steam at 200 lbs. pressure, weight on drivers of 203,000 lbs., and a tractive effort of 46,600 lbs.

These new locomotives have increased the train loads on this division by 28.6 per cent. and observations indicate a considerable saving in coal and water.

The Rocky Mountain division, from Helena, Mont., to Paradise, Mont., is 219 miles long. From Helena to Blossburg there is a maximum grade against eastbound traffic, seventeen miles long, of 2.2 per cent. The balance of the division has a grade against eastbound traffic from Missoula to Garrison, sixty-eight miles of .4 per cent., and from Garrison to Blossburg, thirty-one miles of 1.4 per cent.; all grades are compensated. One Class W-3 locomotive hauls 2,600 tons from Missoula to Garrison at an average speed of sixteen miles an hour. The Class W hauls 2,200 tons at an average speed of twelve miles an hour. Between Garrison and Blossburg one Class Z-1 helper is used. On this division the new Mikados are making 41,600 ton mile hours as against 26,400 for the Class W Mikados, an increase of 57.6 per cent.

Between Helena and Blossburg a Class W-3 locomotive with a Class Z-3 helper is hauling 1,750 tons with no increase in coal over that formerly used by a Class W and a Class Z-1 handling 1,350 tons. This is an increase of 29.6 per cent. in train load, with no increase in coal consumption.

The new Class Z-3 (Mallets) are used on the Rocky Mountain and Seattle divisions, four coal burners on the Rocky Mountain division and six oil burners on the Seattle division. The grades and trains on the Rocky Mountain division are described above, these locomotives being used as helpers between Helena and Blossburg.

The Seattle division, from Ellensburg, Wash., to Auburn, Wash., is 105 miles long, crossing the Cascade mountains through Stampede Tunnel west of Ellensburg at an elevation of 2,837 feet above sea level. These locomotives are handling 2,200 tons from Auburn to Ellensburg at a speed of from eight to fourteen miles per hour, on a total oil consumption of 2,645 gallons. From Auburn to Lester, a distance of 43 miles, the average grade is one per cent. From Lester to Easton, a distance of 24 miles, there is a ruling grade of 2.2 per cent. for ten miles. The Class Z Mallet helper above mentioned is used from Lester to Martin. Westbound, the Z-3 locomotive handles a time freight of 1,900 tons from Ellensburg to Auburn on 1,726 gallons of oil, having a Class Z Mallet helper on the 2.2 per cent. grade.

The design of the new 2-8-2 type locomotives combines a superheater, firebrick arch, smoke consumer tubes in the sides of the firebox and a 36 in. combustion chamber. Included in the design are the builders' latest design of valve stem guide, piston rod extension guide, outside steam pipes, power reverse gear, and outside bearing trailing truck.

Both the oil burning and coal burning Mallets have super-

heaters and power reverse gears; the four coal burning engines are equipped with an arch.

The general dimensions of both types are given in the following table:

General Data.		
Type	Mallet	Mikado
Class	Z 3	W 3
Fuel	Bit. coal	Bit. coal
Tractive effort	87,600 lbs.	57,200 lbs.
Weight in working order	462,000 lbs.	320,000 lbs.
Weight on drivers	401,000 lbs.	240,500 lbs.
Weight on leading truck	34,000 lbs.	30,500 lbs.
Weight on trailing truck	27,000 lbs.	49,000 lbs.
Weight of engine and tender in working order	655,000 lbs.	513,900 lbs.
Wheel base, driving	15 ft.	16 ft. 6 in.
Wheel base, total	55 ft. 2 in.	35 ft. 3 in.
Wheel base, engine and tender	83 ft. 6 1/4 in.	68 ft. 2 1/4 in.
Ratios.		
Weight on drivers ÷ tractive effort	4.59	4.19
Total weight ÷ tractive effort	5.29	5.60
Tractive effort × diam. drivers ÷ evaporating heating surface	900.00	1,002.00
Total evaporating heating surface ÷ grate area	65.8	50.90
Weight on drivers ÷ total evaporating heating surface	72.30	67.00
Total weight ÷ total evaporating heating surface	83.20	89.00
Volume equiv. simple cylinders, cu. ft.	28.64	21.40
Total evaporating heating surface ÷ vol. cylinders	194.00	167.50
Grate area ÷ vol. cylinders	2.95	3.29
Cylinders.		
Kind	Compound	Simple
Diameter and stroke	26 in. x 40 in. & 30 in.	28 in. x 30 in.
Valves.		
Kind	H. P., Piston; L. P., Slide	Piston
Diameter	H. P., 14 in.	16 in.
Greatest travel	6 in.	7 in.
Outside lap	3/4 in.	1 1/2 in.
Inside clearance	H. P., 1/4 in.; L. P., 1/8 in.	0 in.
Lead	H. P., 1/4 in.; L. P., 1/8 in.	1/8 in.
Wheels.		
Driving, diameter over tires	57 in.	63 in.
Driving journals, main, diameter and length	10 1/4 in. x 12 in.	11 1/4 in. x 14 in.
Driving journals, others, diameter and length	10 in. x 12 in.	10 1/2 in. x 14 in.
Engine truck wheels, diameter	30 1/2 in.	33 1/2 in.
Engine truck, journals	7 in. x 13 in.	6 1/2 in. x 12 in.
Trailing truck wheels, diameter	30 1/2 in.	42 in.
Trailing truck, journals	7 in. x 13 in.	9 in. x 14 in.
Boiler.		
Style	E. W. T.	E. W. T.
Working pressure	200 lbs.	180 lbs.
Outside diameter of first ring	87 1/4 in.	83 3/4 in.
Firebox, length and width	126 in. x 96 1/4 in.	120 in. x 84 1/4 in.
Tubes, number and outside diameter	262—2 1/4 in.	212—2 1/4 in.
Flues, number and outside diameter	43—5 1/2 in.	40—5 1/2 in.
Tubes, length	24 ft.	18 ft.
Combustion chamber, length	56 in.	36 in.
Heating surface, tubes	5,170 sq. ft.	3,266 sq. ft.
Heating surface, firebox	368 sq. ft.	325 sq. ft.
Heating surface, total	5,538 sq. ft.	3,591 sq. ft.
Superheater heating surface	1,249 sq. ft.	846 sq. ft.
Grate area	84.3 sq. ft.	70.4 sq. ft.
Smokestack, height above rail	190 3/4 in.	183 1/2 in.
Center of boiler above rail	123 in.	117 in.
Tender.		
Water capacity	10,000 gals.	10,000 gals.
Coal capacity	16 tons	16 tons

NEW LINE FOR ABYSSINIA.—The concession for the construction of the last stretch of the Jibuti-Adis Ababa Railway, the length between the Haua river and Adis Ababa, has been finally granted to the Compagnie de Chemin de fer Franco-Ethiopien, which is now making all arrangements for pushing on with the line as soon as the rainy season is over, that is, in October. The railway will be completed in about two years and is expected very materially to assist in the commercial development of Abyssinia. Attention is drawn to the interest in the trade possibilities of the country being shown by French capitalists, who are displaying considerable activity in securing concessions of various descriptions. It is considered very probable that the near future will witness a large influx of Europeans into Abyssinia, for commercial and industrial possibilities are very promising. There are said to be very few signs of industrial enterprise at present, a few grain mills, two wood sawmills, a small cement works, and a government electrical station and cartridge factory representing the entire industrial plant.

# PENNSYLVANIA PUBLIC SERVICE COMPANY LAW.

A New and Comprehensive Treatment of the Relation of Railroads, Gas Companies and Other Public Servants to the State.

The new law of the State of Pennsylvania for the regulation of railroads and other public service companies is Act 854 of the general assembly of this year, and was approved by the governor on July 26. It consists of six articles and the articles are divided into sections, making 117 sections in all. One of the articles consists of only a single section, but that is made up of 25 subsections. Most of the requirements of this law take effect January 1, 1914, but the commission appointed under it has already been organized. In every case, so far as possible, a section devoted to a given topic is made to apply to all public service companies; and sections applying to railroads and not to gas companies, etc., or to gas or electric companies and not to railroads, are comparatively few.

Article 1, Section 1, defines the term public service company. It includes railroads, telegraph and telephone companies and everything that is mentioned in the interstate commerce law, and also baggage transfer corporations, ferry corporations, tunnel corporations, turnpike corporations, incline plane corporations, gas, water, water-power, heat, refrigerating and sewage corporations, and all persons engaged for profit in the business contemplated by the law; and also municipal corporations to the extent that they carry on these kinds of business. The term railroad includes lines operated by any kind of power. The term street railway includes any line used for the public conveyance of passengers or property, being mainly or in part located on a street or highway. Steamboat lines, other than ferries, are not named in this enumeration; but there is a clause declaring that the term common carrier is to include persons or corporations conveying passengers or property for profit by water.

The term "service" is intended to be used in its broadest and most inclusive sense; and the definition of facilities contains a list of words filling half a page, including all kinds of cars and vehicles and vessels; cables, converters, cross arms, storage batteries, ducts, lamps, docks, gas jets, wells, and everything that could be thought of.

Article 2 defines the duties and liabilities of public service companies. These paragraphs, lettered from *a* to *y* inclusive, can be only partly abstracted in the space here available. It is the duty of such companies (a) to furnish adequate service; (b) to make reasonable rates; (c) to make repairs and improvements as may be necessary; (d) to file tariffs, showing all charges, conditions, etc., including the method of distribution of trains, cars, vehicles, boats and motive power. Tariffs are to correspond with those called for by the federal government where practicable. The commission may restrict the number of tariffs required to be posted.

(e) Joint tariffs are required, and the commission may prescribe the apportionment of rates between different carriers; (f) tariffs may be changed only on thirty days notice. A rate made by the commission may not be changed within three years without approval by the commission, made after application is filed, giving thirty days notice. (g) Copies of all contracts must be filed with the commission; (h) reports must be made and filed as required. (i) Records must be adopted and kept as required by the commission and in the forms prescribed. Included in the records must be a proper and reasonable depreciation account, if required by the commission, and this applies also to municipal corporations with respect to public services rendered by them of the kind contemplated by this law. (j) Companies must keep all suitable books, accounts, records and memoranda, in an office within the state of Pennsylvania, and not remove them out of the state without proper authority; but this does not apply to a public service company of another state engaged in interstate commerce, whose accounts are kept at its principal place of business in another state, in the manner prescribed by the Interstate Commerce Commission. (k) Maps, profiles, re-

ports of engineers and other records must be furnished as called for. (l) Reports must be made to the commission when required, concerning the disposition of the proceeds of all sales of stocks, bonds, notes, etc. (m) Railroads and street railroads must furnish a reasonable number of safe trains, cars, boats, etc.; must operate these with such motive power as may reasonably be required; operate with sufficient frequency and change time schedules when reasonably required by the commission. (n) Railroad and other common carriers must furnish sufficient and suitable cars, boats, etc., to all shippers of freight; or, when the supply is inadequate, distribute without discrimination, in accordance with the rule of the Interstate Commerce Commission; but preference may always be given to live stock or perishable goods. (o) Lateral railroads and private sidings must be treated on reasonable terms and connecting tracks be made where the connection can be made and operated with safety, and the business will justify. If the owner of a private siding sells out to the railroad then all shippers must be treated alike at that side track; they may connect therewith upon payment of suitable compensation. (p) Telephone or telegraph corporations must provide reasonable through and continuous communication without unreasonable interruptions or delay. (q) Bills of lading must be issued and must show that the originating road is responsible through to destination; provision is made for suing connecting carriers for damage to shipments. (r) Street railways must make suitable connections with each other. (s) Railroads and street railways must make and maintain suitable connecting tracks, where practicable, and must transport freight without transfer or discrimination; but no such carrier shall be required to give the use of its tracks or terminal facilities to any other common carrier. It is provided that this subsection (s) shall not apply to a street railway not doing a freight business.

(t) The commission has full power to order the construction of tracks across the lines of other companies; to change grade crossings, elevating or depressing the grade; to require the stationing of watchmen at crossings; the installation of lights, signals, and safety appliances, and to say who shall pay the expense.

(u) Telegraph corporations must connect their lines for through traffic whenever the commission may require. (v) Telephone lines are subject to similar requirements, the intent of the law being to require efficient through service where it can be obtained without injustice to either company and without impairment of its service. Such connecting companies shall make among themselves an equitable apportionment of the cost and revenue. Paragraph *w* regulates the use of gas meters, water meters, etc. The companies must make provision for testing meters. (x) Accidents in which any person shall have been killed or injured, must be reported immediately to the commission. Accident reports shall not be open for public inspection except by order of the commission, and shall not be admitted in evidence in suits for damages, etc. (y) All companies subject to the act are to observe and obey all and singular the lawful orders and regulations which may be issued or made by the commission in the exercise of the powers conferred upon it by this act.

Article 3 defines the powers of public service companies. Section 1 authorizes the collection of reasonable rates for service, the establishment of sliding scales of rates and the establishment of rules for the payment of dividends. A public service company may participate in profits, for the purpose of encouraging efficiency (referring apparently to cases like Chicago, where the city and the street railways divide net receipts). Authority is given to make reasonable classifications of service, of patrons and of rates; to have reasonable rules for conduct of business; to require payment of charges in advance; to allow discounts for prompt payments; to take grievances before the commission.

Allowances made to shippers for service must be no more than just and reasonable.

Section 2 provides for granting by the commission of a certificate of public convenience, after which a public service company may be incorporated, or organized, and exercise its rights. Section 3 provides additional powers in this connection and authorizes municipal corporations to continue existing public service activities. Section 4 authorizes the issuance of stocks, bonds, etc., under suitable regulations and forbids fictitious increases of stock. Application may be made to the commission for a certificate of valuation, to show that a company has complied with this section. Notice must be sent to the commission of intention to issue stocks, bonds, notes, etc., giving full details. Notices of this kind sent to the commission shall be deemed to be public records and open to inspection, and may be given further publicity by the commission. Section 5 authorizes a company, on approval of the commission, to lay tracks across the tracks of other roads. Section 6 forbids the capitalization of franchises, rights, powers or privileges, in excess of the amount paid to the state or city therefor, and makes unlawful the capitalization of leases or contracts, or watering of stock when companies are merged. No company can acquire ownership or interest in any other company without the consent of the commission, except that an interest less than a controlling interest may be acquired without the approval of the commission, if otherwise lawful. Nothing in this act shall affect securities heretofore legally acquired and held, and a company already holding a majority interest in another may acquire additional interest.

Section 7 provides that after January 1, 1914, no public service company shall do business until it has filed and posted tariffs, as required by this law.

Section 8. Unjust discrimination in rates is unlawful, but where a mistake has been made a company is not bound to collect an undercharge, provided the commission, in advance, approves the waiver. Undue preference is forbidden. Section 9 contains a long and short haul provision, like that in the federal law, with a proviso that zone systems of rates are not prohibited. False billing, false description, etc., are forbidden. Excursion and commutation tickets are allowed. Any common carrier may grant free passes, or passes at a discount to any officer or employee of such carrier. Nothing in this act shall prevent telephone, telegraph, express or railroad corporations from contracting with each other for the exchange of service at free or reduced rates, such contracts to be filed with the commission. (There seems to be no provision for passes for members of employees' families or for any persons other than employees, unless it be in this clause relating to contracts for interchange of service.) Section 10 is a long and short haul law for telephone and telegraph companies. Section 11 provides that no contract with a municipal corporation shall be valid unless approved by the commission. Section 12 saves to public service companies their existing rights, except as expressly provided in this law.

Article 4 defines the constitution of the public service commission. Its title is "The Public Service Commission of the Commonwealth of Pennsylvania." (The names of the seven commissioners were given in our former article August 8, page 238.) Appointments by the governor are subject to the consent of the senate. A commissioner must be not less than 30 years of age. A quorum of the commission shall be four members. Four members may act, but their decisions must be unanimous. Section 4 requires all orders to be approved by at least four members. Section 5 defines the duties of the secretary and makes him chief executive officer of the commission. He is to be the disbursing officer and give a bond for \$10,000. Section 6. The attorney general is general counsel and he shall appoint a counsel and an assistant counsel. One of these two must attend hearings before the commission and examine witnesses when requested so to do. Section 7. The marshal is to attend the hearings of the commission and preserve order and superintend the serving of subpoenas, etc. Section 8 provides

for an investigator of accidents. He is to act under the direction of the commission, and also is to investigate any accidents, the happening of which may come to his knowledge; and he is to make a full and complete report to the commission; also report whether any public service company has failed to report an accident; he is to gather statistics and to make an annual report of his investigations, with recommendations as to means or methods whereby accidents may be averted. Section 9 provides for the employment of officers, experts, engineers, statisticians, etc.; and sections 10 and 11 prescribe the salaries.

Section 12 forbids commissioners to have other business; a commissioner must not have business relations with public service companies, or be a candidate for public office. Commissioners must not recommend anybody for employment to a public service corporation. Section 13 forbids public service companies and their officers and employees to offer anything to a commissioner. Section 14: If any employee violates the law the commission must at once dismiss him. Section 15: The governor, with the consent of the senate, may remove a commissioner or any of the counsel, for inefficiency, neglect, misconduct, etc., first giving the accused ten days' notice in writing and an opportunity to be publicly heard. The commission must hold meetings at least twice a month at Harrisburg, and may hold meetings at other places at any time. The office at Harrisburg must be open every business day from 9 a. m. till 5 p. m.

Article 5 defines the powers and duties of the commission. The 29 sections under this article cover, in different phraseology, many of the subjects already dealt with in previous articles. Orders requiring reasonable service or rates must be obeyed by every public service company. When the commission finds rates or service unreasonable or inadequate it shall issue an order making requirements for the future. This includes the power to fix joint rates. The commission may investigate proposed changes in tariffs and, after hearing and investigation, whether completed before or after the change goes into effect, may make such order in reference to the new rates as would be proper in a proceeding initiated after the same had become effective. In cases of this kind the burden of proof, to show that an increased rate is just, shall be upon the public service company. The commission may allow changes in rates within less than the prescribed 30-day limit. Where a decrease in rates is resisted the commission may require the company to give conditional rebate certificates. The commission may order reparation for overcharges, specifying the exact amount to be paid. A claimant who is not satisfied may sue the company in the court of common pleas. Orders requiring reparation must not be made on complaints filed more than two years after the time when the cause of action accrues; and a suit for the enforcement of an order must be filed within one year from the date of the order. No action shall be brought in a court on account of the wrongs and injuries here referred to until the commission shall have made a determination justifying it. (This seems to require that all suits against public service companies for inadequate service or for overcharges shall be brought through the commission.)

Section 6 requires street railway companies to transfer passengers, etc. Section 7 empowers the commission to order track connections and to make through routes and joint rates, but there is a provision relieving a road from joining in a through rate through a junction point which would unduly favor the connecting company. Sections 8 and 9 empower the commission to require telegraph companies to connect with other telegraph lines, and telephone companies to connect with other telephone lines, under reasonable regulations. The commission may divide joint revenue if the companies disagree.

Section 11: The commission may investigate interstate traffic and make complaints to the Interstate Commerce Commission. Section 12 gives the commission exclusive power over all matters connected with the abolition of grade crossings. In no case shall the consent of any court, board, or other commission or

officer, or of any municipality, be necessary. Where practicable, the commission may make general rules or orders to provide for crossing improvements, so as not to require the particular approval of the commission in each case. Where the commission determines the amount of compensation for damages the property owner, may, if necessary, sue the Commonwealth. In apportioning the expenses of changes at crossings, the commission may take into consideration the relative importance to the public of the services rendered by the public service companies concerned, and also priority of location; but where any portion of the cost is assessed on the state or city, such portion shall not be taken into account by the commission in fixing any valuation. Where an order requires relocation of or changes in adjacent structures, poles, pipes, etc., the public service company owning such structures, shall, at its own expense, make the changes. Before making a final order the commission must make an effort to reach an agreement with the cities or towns concerned. It may have crossing changes made by the public service company or by the city or town, or may do the work itself by contract.

Section 15 provides for prescribing a system of accounts. The commission may relieve any public service company from the duty of carrying a depreciation account. It may prescribe the account to which any item shall be charged or credited. Accounts and records must conform to the regulations of the Interstate Commerce Commission where practicable and desirable. The section empowering the commission to prescribe service, authorizes it to revise and change time tables and to alter the running time of trains; to regulate the distribution of cars and generally to make all arrangements and improvements in the service and facilities needed by the public. The power of the commission to determine the fair value of the property of every public service company may be exercised whenever a valuation shall be deemed necessary or proper under any of the provisions of this act.

In ascertaining and determining such fair value, the commission "may determine every fact, matter, or thing which, in its judgment, does or may have any bearing on such value; and may take into consideration, among other things, the original cost of construction, particularly with reference to the amount expended in the existing and useful permanent improvements; with such consideration for the amount in market value of its bonds and stocks, the probable earning capacity of the property under particular rates prescribed by statute or ordinance, or other municipal contract, or fixed or proposed by the commission, and for the items of expenditures for obsolete equipment and construction, as the circumstances and the historical development of the enterprise may warrant; the reproduction costs of the property, based upon the fair average price of materials, property, and labor, and the developmental and going concern value of such public service company; and these, and any other elements of value, shall be given such weight by the commission as may be just and right in each case."

Section 21: When a franchise is valued on the application of a public service company, or other valuations are made on application, the commission must hold public hearings and make a thorough investigation, and the finding of the commission must be in writing, to be known as a "certificate of valuation." No such certificate shall revive or validate any lapsed powers or rights. No certificate of valuation shall be taken as requiring the commission, in any subsequent valuation, to fix a valuation which shall be sufficient to yield a return to the holders of securities, nor shall the commission be bound to prescribe rates or charges which shall be sufficient to yield a return on securities.

The commission may withhold from the public information obtained in investigations.

Article 6 prescribes the procedure before the commission and on appeal, including duties and privileges of witnesses and rights of public service companies and others to make com-

plaints. The Court of Common Pleas of Dauphin County (Harrisburg) is given jurisdiction over appeals, of certain classes, throughout the whole state. No injunction will be issued against the commission except on notice and after cause shown upon a hearing. All proceedings for such injunctions must be brought before the Court of Dauphin County, subject to appeal to the Supreme Court. To this Dauphin County Court the commission goes when it desires an injunction or mandamus against a public service company.

Sections 35-40 of this article provide penalties for violation of the law. Section 45: Nothing in this act shall impair the powers of the Secretary of Internal Affairs; and there is a like provision for other state departments. Section 47 prescribes prices for copies of official documents. The annual report of the commission is to be made on the second Monday of May, and sent to the governor; and a duplicate is to be filed with the secretary of internal affairs. Five thousand copies of the report shall be printed and bound in cloth. Section 51 repeals the railroad commission law and a number of others. The law of June 19, 1911, to promote the safety of travelers and employees on railroads, is continued in full force and effect.

Though the new law goes into effect only at the end of this year, the commission may require public service companies to file tariffs, rules and regulations after October 1. Section 11, article 3, requiring contracts to be approved by the commission, also goes into effect at once.

### NOMOGRAPHIC METHOD FOR FINDING CENTER OF GRAVITY AND MOMENT OF INERTIA.

The usual method of finding the center of gravity and moment of inertia of rail sections is to divide the section into narrow strips of equal width and then, considering the area of these strips as forces, to construct a polygon of forces. This method is illustrated in Fig. 1 for a 100 lb. section. In this case the strips have been taken as 1/4 in. wide and the middle ordinate of each strip was laid off in the construction of the force polygon to one-half scale. Since the summation of the middle ordinates of all the strips in the half section, multiplied by the width of a strip, 1/4 in. is equal to the area of the half section, the area of the total section is equal to twice this product or 1/2 the summa-

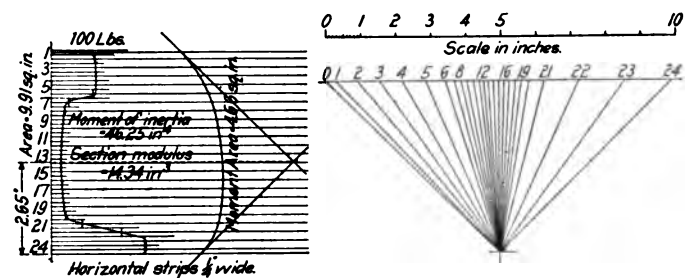

Fig. 1—Common Method of Determining Center of Gravity and Moment of Inertia by Force Polygon.

tion. By plotting these middle ordinates to one-half the scale used in the cross section, the scaled distance representing the summation of these lengths when expressed in square inches is the area of the total rail section. The center of gravity is located in the common method by the intersection of the two extreme forces in the polygon and the moment of inertia by multiplying the area of the section by the area enclosed between the force polygon and the two extreme forces. The principal objection to this method is that the natural errors in drawing the force polygon are cumulative and therefore extreme care must be taken in making this drawing to get reasonably accurate results. The so-called moment area is obtained by the use of a planimeter.

The new method consists in drawing a "curve of moments"



and a "curve of inertia" for the section under consideration and measuring their respective areas by the planimeter. The ordinates used in plotting these curves are secured by reading a simple nomogram and the method constitutes an easy way of drawing the integral curve for these particular problems.

In order to explain properly the principles upon which this new method is based it is necessary to recall some of the principles of integral calculus, particularly the fundamental one that the area of a curve,  $y = f(x)$  designated by  $A$ , is:

$$A = \int_{x_0}^x f(x) dx$$

This is the expression for the area between the curve and the  $X$  axis limited by the ordinates  $x$  and  $x_0$ . For the purpose of finding the moment of a given area about the axis  $X$ , we consider the weight of each vertical strip as equivalent to its area concentrated in the center of gravity of the strip, which in this case is easily seen to be half of the ordinate or height of this particular strip. If  $m$  is equal to the moment of the area of one elementary strip then:

$$m = \frac{y}{2} \times y \Delta x$$

and if further,  $M$  is equal to the moment of the entire area, then:

$$M = \Sigma m = \Sigma \frac{1}{2} y^2 \Delta x$$

This expression means that we must find the sum total of all the halved squares of the successive middle ordinates and multiply this sum by the width of the strips in order to find the total moment of area. If we consider the width of these strips as infinitely small then the summation becomes an integral and we can write:

$$M = \frac{1}{2} \int y^2 dx$$

The moment curve for the 100 lb. rail section used in Fig. 1 is shown in Fig. 2. The axis  $OX$  may be taken in an arbitrary manner but in order to reduce the size of the resulting diagram it is better to place it as near as possible to the center of gravity judging by the eye. As the section is symmetrical, the center of gravity is obviously located on the vertical center line, but in the case of an unsymmetrical section the process would be repeated for a second axis taken at right angles to the first. In constructing the moment curve a few ruling points in the outline of

the corresponding value of  $y^2/2$  can be read directly. This nomogram is read simply by passing from one side of the graduated line to the other and the value of  $y^2/2$  so obtained is plotted to the same scale with which the ordinate was measured. The scales of inches are added in this figure to enable the reader to follow

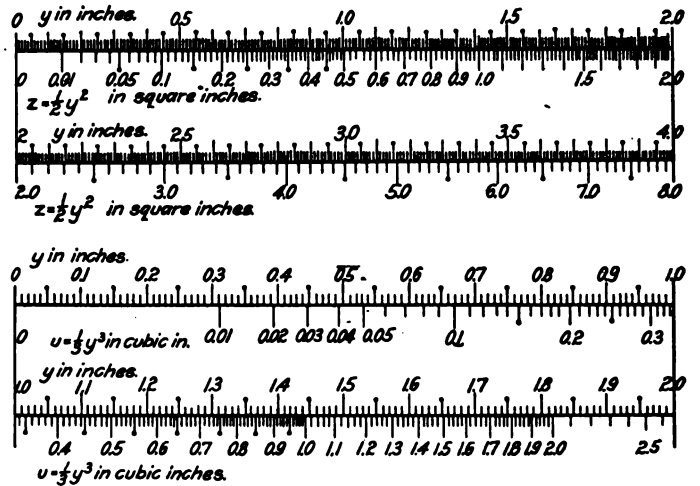

Fig. 4—Nomogram for Use in Constructing Moment and Inertia Curves.

the construction independently of the reduction in the engraving. Since it was shown above that the total moment of the section equals:

$$\left(\frac{1}{2}\right) \int y^2 dx$$

it is evident that the area of the moment curve represents the moment of the section. The  $X$  axis will pass through the center of gravity only when the moments on the two sides of the axis are equal or, in other words, when the area of the curve above and below the axis is the same. Measuring the areas in Fig. 2 it is found that the moment curve above the  $OX$  axis has an area of 4.98 sq. in. and that below this axis 5.05. This indicates that the center of gravity is below the axis  $OX$  and the distance between  $OX$  and the true neutral axis is found by dividing the difference between the areas of the moment curves by the area of the half section of the rail which gives:

$$\frac{5.05 - 4.98}{4.955} = 0.014 \text{ in.}$$

As the distance from the base line of the section to the  $OX$  axis was taken as 2.65 in., which was the distance obtained in Fig. 1, the shift of 0.014 in. indicates the greater accuracy of the new method. The corrected distance from the base line to the center of gravity is therefore 2.636 in.

By a similar line of reasoning the corresponding method for obtaining the moment of inertia is derived. In the case of a body in general the moment of inertia is defined as the summation of the products of the weight of each particle by the square of its distance from a given axis. If in a curve represented by the equation  $y = f(x)$ ,  $y$  represents the height of a strip of the width  $\Delta x$  and we take out of this strip an element of height  $\Delta y$ , calling the distance from the center of gravity of the element to the  $X$  axis  $y_1$ , then the finite element of the moment of inertia for this element of area is:

$$\Delta I = (\Delta y_1 \Delta x) y_1^2$$

and the summation of all such elements will be:

$$I = \Sigma y_1^2 \Delta y_1 \Delta x$$

The first part of this summation is equal to the definite integral:

$$\int_0^y y_1^2 dy_1 = \frac{y^3}{3}$$

and accordingly we get for the total summation the definite integral:

$$I = \left(\frac{1}{3}\right) \int_{x_0}^x y^2 dx$$

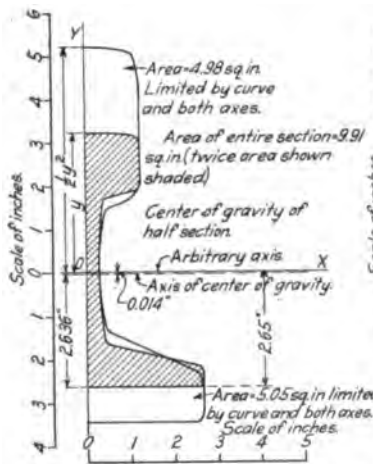

Fig. 2—Location of Center of Gravity by Drawing "Moment" Curve.

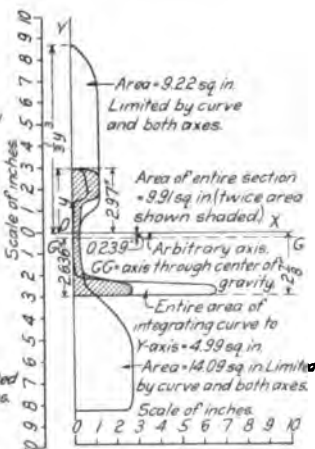

Fig. 3—Determination of Moment of Inertia by Construction of Inertia Curve.

the section are taken and the distances from those points to the  $OX$  axis are measured and considered as the ordinates of those points. By plotting on lines drawn through those points at right angles to the  $OX$  axis the values of  $y^2/2$ , corresponding to the value of  $y$  at each point, the ruling points in the moment diagram are located. In order to get these values of  $y^2/2$ , the ordinate can be measured with a rule graduated decimally in inches and using this value in the nomogram shown in Fig. 4,

The diagram Fig. 3 shows how this integration is effected by the help of a planimeter by constructing the curve of inertia for the same rail section as in the previous examples. The axis *OX* is taken arbitrarily and the values of  $\frac{1}{2} y^2$  used in plotting the inertia curve are obtained from the second nomogram in Fig. 4. The use of this nomogram for finding this curve is the same as that described in connection with Fig. 2. The total moment of inertia about the *OX* axis is represented by the area of its inertia curve, which is shown by the planimeter to be 9.22 sq. in. above the axis and 14.09 sq. in. below it. The moment of inertia of the total section is equal to twice the sum of these areas or:

$$2 (9.22 + 14.09) = 46.60 \text{ in.}^4$$

The minimum total moment of inertia which is that in respect to the axis *GG* through the center of gravity is found by the well known rule covering moments of inertia about parallel axes, namely:

$$I_g = 46.60 - 9.91 \times (0.239)^2 = 46.03 \text{ in.}^4$$

The so-called section modulus is found by dividing this minimum moment of inertia by the maximum distance from the axis through the center of gravity to the edge of the section. In this case this is equal to:  $46.03/3.209 = 14.34 \text{ in.}^3$ .

**ACCIDENT BULLETIN NO. 46.**

The Interstate Commerce Commission has issued quarterly accident bulletin No. 46, containing the record of railway accidents in the United States during the three months ended December 31, 1912. The number of persons killed in train accidents was 250, and of injured, 4,334. The total number of casualties of all classes, including industrial accidents, was 2,967 killed and 51,323 injured. "Industrial Accidents" are those occurring to employees where the movement of cars or engines is not involved. The accidents are summarized as follows:

TABLE NO. 1.—CASUALTIES TO PERSONS—STREAM RAILWAYS.

Causes.	Passengers.		Employees (including employees not on duty).		Other persons (trespassers and non-trespassers).		Total persons.	
	Kil'd.	Inj'd.	Kil'd.	Inj'd.	Kil'd.	Inj'd.	Kil'd.	Inj'd.
<b>Train accidents.</b>								
Collisions .....	42	1,313	107	1,078	11	24	160	2,415
Derailments .....	15	1,079	45	483	7	33	67	1,595
Miscellaneous train accidents (416) .....	..	13	22	310	1	1	23	324
<b>Total .....</b>	<b>57</b>	<b>2,405</b>	<b>174</b>	<b>1,871</b>	<b>19</b>	<b>58</b>	<b>250</b>	<b>4,334</b>
<b>Other than train accidents.</b>								
Accidents to roadway or bridges not causing derailment (104) ..	..	..	..	..	..	..	..	..
Other accidents (classes C-3 to C-12, inclusive) ..	57	1,923	790	13,730	1,764	3,076	2,611	18,729
<b>Total .....</b>	<b>114</b>	<b>4,328</b>	<b>964</b>	<b>15,601</b>	<b>1,783</b>	<b>3,134</b>	<b>2,861</b>	<b>23,063</b>
<b>Industrial accidents to employees.</b>								
While working on tracks or bridges ..	..	..	27	5,988	..	..	27	5,988
At stations, freight houses, engine houses, etc. ....	..	..	36	6,649	..	..	36	6,649
In and around shops ..	..	..	29	13,422	..	..	29	13,422
On boats and wharves ..	..	..	8	508	..	..	8	508
At other places .....	..	..	6	1,693	..	..	6	1,693
<b>Total .....</b>	<b>..</b>	<b>..</b>	<b>106</b>	<b>28,260</b>	<b>..</b>	<b>..</b>	<b>106</b>	<b>28,260</b>
<b>Grand total .....</b>	<b>114</b>	<b>4,328</b>	<b>1,070</b>	<b>43,861</b>	<b>1,783</b>	<b>3,134</b>	<b>2,967</b>	<b>51,323</b>

TABLE NO. 1A.—COMPARISON WITH FORMER QUARTERLY RECORDS.

No.	Item.	Bulletin 46.	Bulletin 45.	Bulletin 42.
1	Passengers killed in train accidents.....	57	88	27
2	Passengers killed, all causes .....	114	156	78
3	Employees (on duty) killed in train accidents.....	170	153	183
4	Employees (on duty) killed in coupling.....	54	32	53
5	Employees (on duty) killed, total.....	861	712	850
6	Total passengers and employees (items 2 and 5, above) .....	975	868	928
7	Other persons killed (including trespassers, non-trespassers, and employees not on duty), all causes .....	1,886	2,127	1,798
8	Employees killed in industrial accidents.....	106	114	78
	<b>Grand total (items 6, 7, and 8).....</b>	<b>2,967</b>	<b>3,109</b>	<b>2,804</b>

The total number of collisions and derailments in the quarter under review was 3,994 (1,859 collisions and 2,135 derailments),

of which 229 collisions and 194 derailments affected passenger trains. These are classified as follows:

TABLE NO. 2.—COLLISIONS AND DERAILMENTS.

No.	Classes.	Number.	Damage to road and equipment.	Number of persons—	
				Kil'd.	Inj'd.
<b>Collisions—</b>					
1	Rear .....	359	\$440,352	65	850
2	Butting .....	184	372,432	63	722
3	Trains separating .....	128	53,633	2	91
4	Miscellaneous .....	1,188	553,931	30	752
	<b>Total .....</b>	<b>1,859</b>	<b>\$1,420,348</b>	<b>160</b>	<b>2,415</b>
<b>Derailments due to—</b>					
5	Defects of roadway.....	488	\$454,412	18	634
6	Defects of equipment .....	1,041	864,264	9	226
7	Negligence .....	156	85,047	8	174
8	Unforeseen obstruction .....	63	111,435	9	175
9	Malicious obstruction .....	16	26,152	3	43
10	Miscellaneous causes .....	371	447,295	20	343
	<b>Total .....</b>	<b>2,135</b>	<b>\$1,988,605</b>	<b>67</b>	<b>1,595</b>
	<b>Total collisions and derailments....</b>	<b>3,994</b>	<b>\$3,408,953</b>	<b>227</b>	<b>4,010</b>
<b>Total for same quarter of—</b>					
	1911 .....	3,346	\$2,893,948	230	4,132
	1910 .....	3,366	2,831,469	219	3,175
	1909 .....	3,206	2,733,830	220	3,731
	1908 .....	2,684	1,940,133	173	2,616

The usual tables are given classifying certain accidents in detail. Table 1b is an amplification of Table 1. Table 3 divides into twenty-eight sub-classes the causes of accidents to employees in coupling and uncoupling cars. Table 3a classifies these same accidents according to the nature of the injuries. Table 4 divides into eighteen sub-classes the causes of accidents to employees due to falling from cars and getting on or off cars.

Table 2a divides into eight sub-classes derailments due to defects of roadway; Table 2b divides into thirteen sub-classes those due to defects of equipment. Table 1b gives a surgeon's classification of the 23,063 injuries to passengers, employees and others, which are summarized in table No. 1. There are 32 classes. For example, of the 23,063 injuries, 3,651 are classed as contusions of the body; 3,945 are sprains; 1,036 are entered in the table as "slight" injuries, and 1,647 are entered as not clearly described.

Tables 4a, 5a and 8a sub-divide the causes of miscellaneous accidents on or around the trains; of cases where trainmen strike overhead bridges, etc., and of miscellaneous accidents on or around the trains to passengers and to employees not engaged in work connected with the operation of the train.

Twenty-five accidents occurring during this quarter were investigated by the inspectors of the commission, and the reports of these investigations fill 41 pages of the bulletin. The accidents occurred as follows:

Baltimore & O. S. W. ....	W. Athens, Ohio.....	Oct. 2..	Butting collision
New York, N. H. & H. ....	Westport, Conn. ....	Oct. 3.....	Derailment
Western Maryland .....	Kobeen, Pa. ....	Oct. 7..	Butting collision
Baltimore & Ohio.....	Chicago Junction, Ohio..	Oct. 10.....	Rear collision
Louisville & Nashville...	Cunningham, Ala. ....	Oct. 12.....	Derailment
Delaware, L. & W. ....	Hallstead, Pa. ....	Oct. 18.....	Rear collision
Illinois Central .....	Hopkinsville, Ky. ....	Oct. 20.....	Derailment
Norfolk & Western.....	Cooper, W. Va. ....	Oct. 20.....	Derailment
Lehigh Valley .....	Hornets Ferry, Pa. ....	Oct. 27.....	Rear collision
Western & Atlantic.....	Emerson, Ga. ....	Nov. 8.....	Butting collision
Yazoo & Miss. Valley...	Montz, La. ....	Nov. 12.....	Rear collision
Cincinnati, H. & D. ....	Indianapolis .....	Nov. 13.....	Butting collision
New York, N. H. & H. ....	Green's Farms .....	Nov. 16.....	Derailment
New York, N. H. & H. ....	Putnam, Conn. ....	Nov. 16.....	Rear collision
Seaboard Air Line.....	Granite, N. C. ....	Nov. 16.....	Butting collision
Texas & Pacific.....	Alexandria, La. ....	Nov. 23.....	Rear collision
Western Maryland .....	Blue Mountains, Md. ....	Nov. 27.....	Butting collision
Pennsylvania .....	Glen Loch, Pa. ....	Nov. 27.....	Derailment
Pennsylvania .....	Dresden, Ohio .....	Dec. 3.....	Rear collision
Western Maryland .....	Pen Mar, Pa. ....	Dec. 6.....	Butting collision
Northern Pacific .....	Toppenish, Wash. ....	Dec. 10.....	Butting collision
Atchison, T. & S. F. ....	Williams, Ariz. ....	Dec. 10.....	Rear collision
Great Northern .....	St. Paul, Minn. ....	Dec. 10.....	Rear collision
Baltimore & Ohio.....	Glencoe, Pa. ....	Dec. 12.....	Derailment
Pennsylvania .....	Bowerston, Ohio .....	Dec. 13.....	Rear collision

Electric railways reporting to the commission (not included in the foregoing statistics) had 111 persons killed during the quarter and 1,387 injured; and there were 61 collisions and 18 derailments. Train accidents are charged with 7 fatalities. The total number of passengers killed from all causes was 8, and of employees 16 (3 in industrial accidents). The number of trespassers struck or run over by cars was 55; 29 killed and 26 injured.

## A NATIONAL PROBLEM.\*

Foodstuffs of nearly every sort have increased in cost during the past dozen years, while in the United States, with the notable exception of beef cattle, the production of foodstuffs has not lessened, but, on the contrary, has greatly increased.

As to the reasons for the increases in cost of living, the economic doctors disagree. It is enough here and now to state that the problem exists and that a great transportation agency—ideally equipped for the handling of perishable food products—is going to use its best wits and its best energies to help in the solution of that problem. The transportation agency is the express, and the particular express that is going to make the effort is the express of Wells Fargo & Company.

The company realizes that it is now necessary to bring into being an organization, studying all the phases of the problem and moving in harmony with them. To that end it has enlarged its former order and commission department into the order, commission and food products department, which came into existence August 1. It will join hands with all forces interested in the research of the cost-of-living question. The question is largely one of the distribution of food products in which the farmer and other producers, the distributor, the consumer and the carrier are mutually interested.

Wells Fargo & Company has maintained an order and commission department for many years, through which it has performed various public services, such as attending to commission for purchase and sale of goods, the recording of deeds, the payment of taxes, the reclaiming of baggage or other goods of value. The largest function of this department has been the promotion of the growth and production, especially in the west and southwest, of fruit and vegetable traffic, by first maintaining a corps of trained industrial agents at all seasons of the year to aid the producer in finding suitable location and soil, and, second, by assisting in securing markets for his production, and then in providing convenient, speedy and safe transportation. Practically all of the immense shipments of vegetables, berries, melons and other fruit which now move in carloads and train loads had their beginnings in small shipments by express. The express rates and service furnished transportation facilities necessary for the development of a great industry, and which were not otherwise available.

From these beginnings came the refrigerator car. It is worthy of recording here and now that the first refrigerator car ever built for passenger train service was built by Wells Fargo & Company, and that it went into service hardly more than a decade ago.

The order, commission and food products department comes as an outgrowth of the former order and commission department. The organization, which will be connected with the traffic department of the company, will consist of a manager and a group of industrial agents, who will direct the work, which will be performed, in its details, by the agencies and employees of the company.

The aim of the department will be to study the food products problem from various viewpoints, and to encourage and assist growers and producers by aiding them in the finding of suitable markets among dealers and consumers, and in the securing, at minimum cost, of suitable sanitary packages or containers in which to ship. It is a well-established fact that one of the greatest obstacles to an increased shipment by farmers and small producers in general, of fruits, vegetables, poultry and the like, has been the lack of availability of satisfactory containers in which safely to make shipments in small quantities.

Careful inquiry does not indicate a general shortage in the supply of food products; the difficulty seems to be that the system of distribution has not kept pace with the growth of the country, and that it is in many details complicated and expensive, particularly in the larger cities. In towns a greater quan-

tity and variety of seasonable fruit, vegetables and the like would be consumed if there was an organization having definite information regarding the produce that could be sold and where it could be obtained in producing and distributing sections. It is intended that this department shall gather information that will enable the producer, the distributor, the consumer and the carrier to keep more closely in touch with each other, to the very material benefit of all.

Agents of Wells Fargo & Company will be called upon by the food products department for names of growers and shippers of food products from their stations. The department will be anxious to know about the containers or shipping packages now in use—and those required by prospective shippers. The names of dealers, both wholesale and retail, of hotels, restaurants and co-operative clubs will be sought by the department. Its facilities will be extended to all interested in food production or consumption—the grower, producer and distributor, as well as the consumer. In this department the consumer who prefers to purchase foodstuffs direct from the producer will find a valuable aid.

An important function of the new department will be the publication of bulletins in booklet form and at frequent intervals. These will be intended for large distribution and will deal not only with what the department is doing in general, but also with specific and unusual offers, such as the shipment of individual packages of fruits, vegetables, nuts and the like.

At present there is a tendency toward indiscriminate shipments to points where markets either do not exist or have already been supplied. This results in unsatisfactory returns to growers, and to improve on this condition, constant communication will be maintained between the food products department and our agents in those districts where produce is raised in considerable quantities. By this means, advice can always be had well in advance of the movement of the crop as to its probable volume, and the date when it is likely to move. This will enable the company to assist in finding a market and should result in the products being distributed to better advantage.

## THE G. R. S. TRAIN DESPATCHER'S SELECTOR.

The General Railway Signal Company, Rochester, N. Y., has issued bulletin No. 114B, describing its train despatcher's telephone selector system, which is now in use under exacting conditions on a number of important circuits. With the completion of contracts on which work is now under way, this apparatus will be in service on nine circuits, aggregating 922 miles. On these circuits there are 283 selectors and 291 bells. Five of these circuits are on the New York Central & Hudson River, three on the Illinois Central and one on the Toronto, Hamilton & Buffalo. Current is furnished by motor generators in all of these installations except on the T. H. & B., where dry battery is used.

One of the first installations of these instruments was on the Rochester division of the New York Central, between Rochester and Niagara Falls, 76 miles. During the year ending April, 1913, there was on this line an average of 544 calls per day, and a maximum of 959. The current consumed was 475 kilowatt hours. In this circuit the motor generator is operated from a storage battery, which is on float charge from 110 volts d. c. commercial circuit. This circuit is to be extended to include another division; and then the motor generator will be operated direct from a commercial circuit, with the storage battery in series with the motor circuit, which will materially reduce the current consumption. Standard time is transmitted by the selector equipment on this circuit.

One circuit on the Adirondack division of the New York Central using this apparatus comprises 250 miles of line, 49 selectors and 56 bells. The line voltage required is 400, which

\*From an article in the *Wells Fargo Messenger* for August, 1913.

is normally supplied by an A. C.-D. C. motor generator, operated from a three-phase, 110-volt, 60-cycle commercial circuit. The storage battery will be charged by an A. C.-D. C. charging set. An extra D. C.-D. C. line motor generator is to be provided as a reserve, so that in the event of a failure of the commercial circuit the line can be operated from the storage battery.

This selector apparatus is described in the Signal Dictionary, page 128, and is specially designed for economical consumption of power. The selector requires a small number of impulses to each call. The apparatus has no time element device and no preliminary or clearing impulses are used in its operation.

### HERVEY LOCOMOTIVE STOKER.

The Hervey stoker, which is of the top feed or scatter type, was used on a Mikado type locomotive on the Baltimore & Ohio between Philadelphia and Baltimore, making a total of 6,500 miles. The most noticeable feature about it is the distributor, which is constructed like a fan. In order to properly distribute the coal to all parts of the firebox the blades of the distributor are so deflected as to deliver the fuel first to one side and then to the other. This distributor is so arranged in its casings that

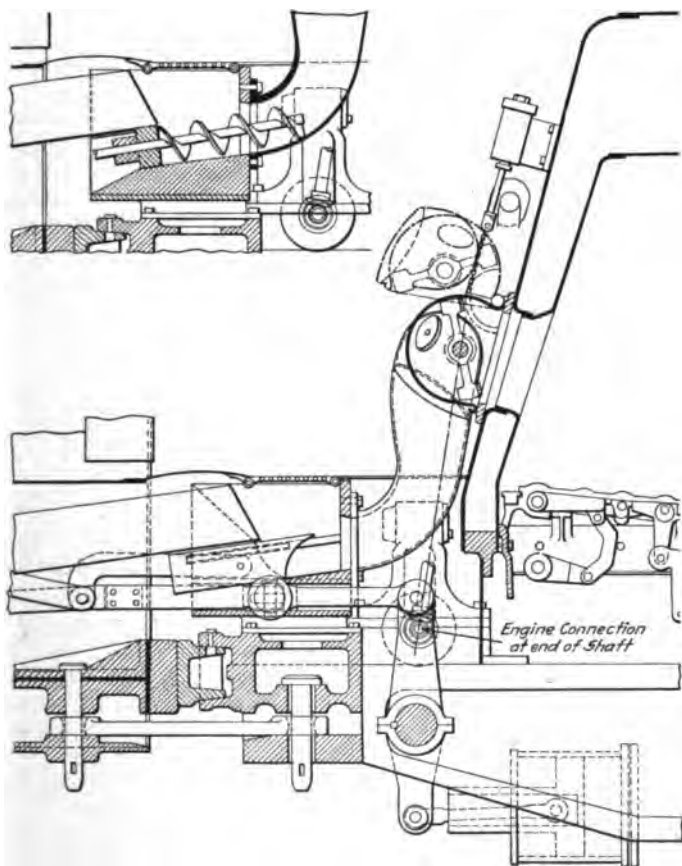

Hervey Locomotive Stoker with the Crawford Conveyor.

it may be swung out of the way in case it is necessary to resort to hand firing.

The coal may be delivered to the distributor either from above or below. The illustration shows an application of the Hervey stoker to a Pennsylvania Lines locomotive in connection with the Crawford tender feed arrangement. A special type of screw conveyor is employed in this case and is shown in the small view. A 7 h. p. steam engine is used to drive both the conveyor and the distributor, this being accomplished through the use of bevel gears. In this application the screw conveyor passes the coal up through the feed passage to the distributor. This stoker was invented and patented by D. F. Hervey, Logansport, Indiana.

### IMPROVED COAL SPRINKLER.

Among the devices recently placed on the market for the use of locomotive firemen in sprinkling coal is the ejector which was developed by the Hancock Inspirator Company, Boston, Mass., and was described in the *Railway Age Gazette*, June 27,

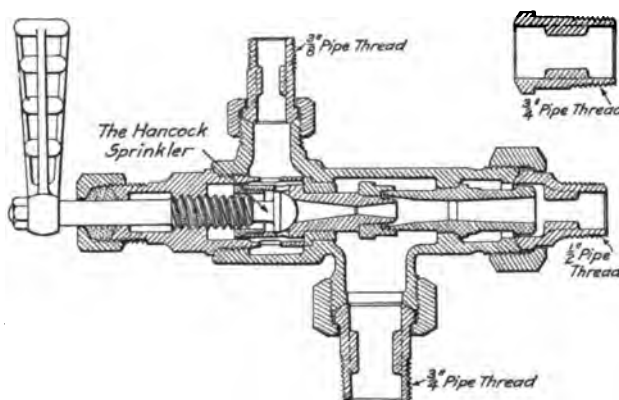

Section Through the Hancock Improved Coal Sprinkler.

1913, page 1613. Investigation of the subject of coal sprinklers has convinced the manufacturers that, as a safeguard, the apparatus should be operated entirely by one handle, so arranged that the water connection will positively be closed when

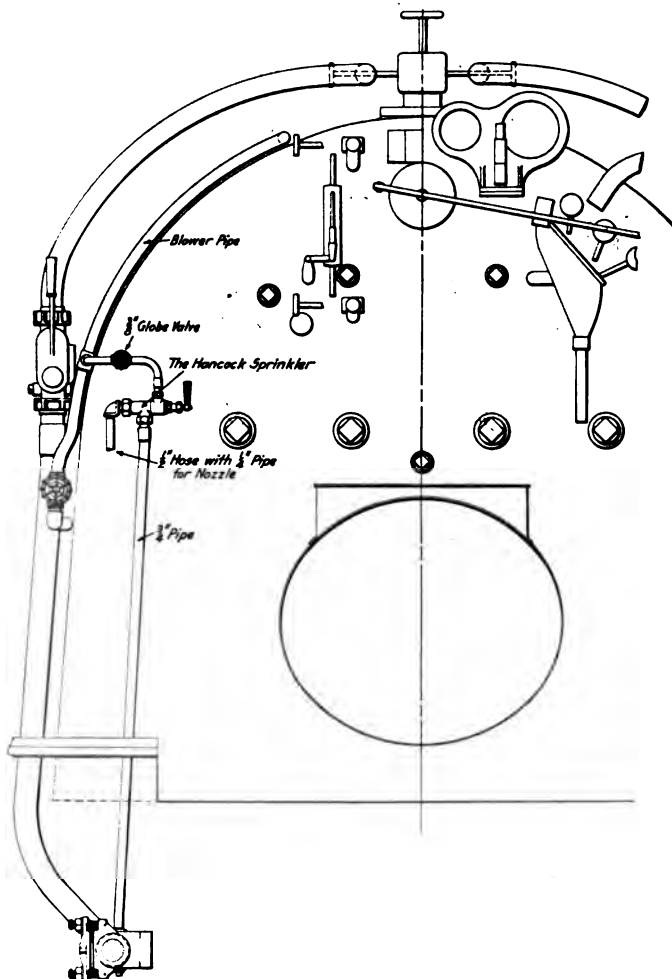

Location of the Hancock Coal Sprinkler in a Locomotive Cab.

the sprinkler is not in operation. Unless the water passage is entirely closed when the injector is used for heating the water in the tank, steam is likely to back up through the suction pipe of the sprinkler and result in injury. With sprinkling devices having

separate valves for the steam and water connections, there is always the possibility that the man operating the device will forget to open the water valve in the suction when starting the sprinkler, or forget to close it when shutting off the sprinkler. In an improved coal sprinkler which has been devised by the Hancock Inspirator Company, only one handle is used, and this operates both the steam and water valves. As shown in the drawing of the cross section, the sliding steam nozzle is so constructed that its front end overlaps the back end of the combining tube when the steam valve is closed, thus effectually closing the water opening; when the steam valve is open the steam nozzle which is attached to it is drawn back from the combining tube at the same time that the steam port is opened. The sprinkler, as shown in the other illustration, is located on the left hand side of the cab and takes its water supply from the suction pipe of the injector through a  $\frac{3}{4}$  in. pipe. A  $\frac{3}{8}$  in. globe valve is placed in the steam supply pipe to shut off the steam from the sprinkler when necessary.

### EQUALIZED SWING-MOTION TENDER TRUCK.

A locomotive tender truck that has proved satisfactory with high speed locomotives, has recently been perfected by the Commonwealth Steel Company, St. Louis, Mo. It has a swing-motion bolster carried on three-point hangers which are so designed as to support the tender in a stable manner without responding laterally to slight track imperfections, such as low joints, etc. The truck frame, in many respects, follows the design which has been previously used by this company for four wheel passenger car trucks and combines the cross transoms



Equalized Tender Truck with Swing-Motion Bolster.

and the wheel pieces in one steel casting. It is claimed that with the three-point hanger for the bolster, the impact between the wheel flange and the rail when entering a curve at high speed is greatly reduced, because the cistern is lifted by the side swing of the bolster and thus tends to throw the whole truck away from the rail. The truck is equalized in practically the same manner as a passenger car truck, the wheel pieces being supported on the equalizers by large single coil springs placed as close as possible to the boxes. It will be noted that the springs supporting the bolsters are set well in toward the center, thus tending to keep all weight well inside the gage limit and defeating any tendency to lift the wheels from the rail.

**C. P. OBSERVATION CARS FOR SWITZERLAND.**—Following an agreement between the Swiss Federal Railways and the Canadian Pacific, the latter has extended the existing observation car service in Austria, which was inaugurated last year, to Switzerland, and the new service of cars started on August 26. Hitherto these Canadian Pacific observation cars have been confined to the three Austrian services, viz.: from Trieste to Salsburg; Vienna to Innsbruck; and from Innsbruck to Buchs. The latter service now crosses the border between Austria and Switzerland at Buchs.

## General News.

The annual picnic of the Railroad Club of Kansas City will be held at Fairmount Park on Saturday, August 30.

Representative Nolan, of California, has introduced in Congress a bill to prohibit interstate transportation of goods produced by convict labor.

The New York, New Haven & Hartford, during the last fiscal year, has distributed among the farmers along its lines the sum of \$1,200,000 in payment for sleepers and fence posts, mostly in western Connecticut and Massachusetts.

Officers of the Burlington road have this week agreed with the representatives of the company's conductors and brakemen, following long discussions with the government mediator, that the questions concerning wages which are now pending shall be submitted to arbitration.

The Canadian Pacific is planning to more than double its use of oil as fuel for locomotives. This fuel is now used on the engines between Field, B. C., and Kamloops, 260 miles, and the engines are now being fitted for it on the line extending west from Kamloops to the Pacific coast, about 250 miles.

The Central of Georgia employs women as stenographers, typists and clerks in the car record office, and also in considerable numbers in the accounting department. The press despatch, recently printed, to the effect that a larger proportion of women will be employed in the future, applies only to the accounting department.

"First Aid to the Injured" is the subject of the opening article in the Buffalo, Rochester & Pittsburgh Employees' Magazine for August; and three employees are specially mentioned because of prompt and intelligent services in behalf of injured persons; Conductor F. W. Knapp, Conductor M. E. Moynihan and Miss Veronica M. Larkin, a telegrapher.

The Agricultural Department announces that about 125,000,000 ft. of timber will be sold from the Bonneville National Forest, Wyoming. A period of eight years will be allowed for cutting the timber and the minimum prices are \$2.75 per M. ft. for logs; \$1.50 per M. for posts and  $8\frac{1}{2}$  cents each for hewed sleepers. The timber is principally lodge pole pine, spruce and fir.

The Pennsylvania Railroad, which keeps small quantities of dynamite at certain points along the line of the road for use in case rocks should fall on the track, has adopted, for the safe keeping of the dynamite, a standard plan for a small ventilated, bullet proof and fireproof building. This building in its construction will conform to the requirements of the Bureau of Explosives.

Figures brought out at the hearing before the California Railroad Commission on July 30, showed that during the month of June the Southern Pacific carried on its suburban and ferry service between San Francisco and Alameda county, 1,733,191 passengers. The company has given out a statement to the effect that it is losing \$750,000 yearly on this suburban ferry and train service in Alameda County, where costly electric propulsion has recently been introduced.

The twenty-fourth annual report of the relief department of the Chicago, Burlington & Quincy for the calendar year 1912 shows total disbursements of \$596,792, of which \$563,158 was contributed by members, \$20,625 represented income from investments and \$13,009 was advanced by the railroad. The company has now advanced a total of \$51,272. Since the department was organized in 1889 it has paid out a total of \$8,834,394, on account of sickness and accidents. The membership in 1912 was 26,328.

The western section of the engineering committee appointed by the railways to confer with the engineering board of the Interstate Commerce Commission on matters connected with the valuation of the railways, held meetings last week in Chicago on August 19, in St. Louis on August 20, and in Denver on August 22, for the purpose of discussing the tentative specifications for maps and profiles issued by the commission. At each place the committee conferred with engineers of the roads in the immediate territory.

Sir Richard McBride, prime minister of British Columbia, in a recent newspaper interview at New York, advocated the construction of a railroad from the state of Washington to Alaska, across British territory, declaring such a line necessary in the interests of this country and expressing the belief that Canada would be only too willing to favor such a project. The minister's idea was that, with access by sea alone, this country could not properly defend Alaska in case of war. On Tuesday of this week Representative Johnson, of the state of Washington, introduced in Congress a joint resolution, requesting President Wilson to negotiate with the British and Canadian governments for the establishment of a railroad, as proposed by Sir Richard.

The British postmaster general, in a letter to the Cunard Steamship Company, in relation to running special mail trains between London and Holyhead, says that the London & Northwestern has demanded increased compensation and that, in the opinion of the postmaster general, the increase is reasonable. For service which has been performed for the sum of £5,510, the company demands £7,038 per annum; and this increase is based on (1) an increase of operating expenses, which makes it necessary to charge for special trains 5 shillings a mile instead of 4s. 6d.; and (2) the cost of running a vessel from Holyhead to Ireland has increased so that the charge for this service must be made £100 instead of £80. It appears that for these special trains the Cunard company pays one-third of the cost.

After mediation by G. W. W. Hangar of the United States board of mediation and conciliation the Southern Pacific and its trainmen have agreed to submit to arbitration their controversy regarding the status of employees on the company's electric lines. The board of arbitration will consist of Max Thelen, member of the California Railroad Commission; W. R. Scott, general manager of the Southern Pacific, and M. E. Montgomery, assistant chief of the Brotherhood of Locomotive Engineers. Hearings will begin on September 1. The railroad company contends that certain of its electric cars in Alameda county, which are operated under a street car franchise and stop at every crossing, should be run on a different basis from through suburban service, stopping only at regular stations.

The "Safety First" bulletin of the Delaware, Lackawanna & Western gives, in its last issue, a condensed statement of the deaths and injuries of employees on that road during the last three fiscal years and shows decided decreases, the figures for the three years, 1911, 1912 and 1913 being as follows: Killed 34, 21, 19; injured 137, 121, 109. This result is attributed in large measure to the work of the safety committees. This bulletin contains the portraits of the seven members of the general safety committee. It contains also some verses on safety written by a school girl, 13 years old. The general committee, through its secretary, William C. Wilson, 90 West street, New York City, offers a prize of \$25 for a poem on the subject of safety from accidents, open to sons and daughters of employees of the road. There is a second prize of \$15 and another of \$10.

#### Electrification in British Columbia.

The Canadian Pacific is planning to electrify its line between Rossland, B. C., and Castlegar, 29 miles. The power will be direct current, 2,400 volts, the system being similar to that in use on the Butte, Anaconda & Pacific.

#### Making Change in Selling Tickets.

If in making change the amount of the fare is distinctly named and the change then counted out to the passenger from such amount up to the amount of money received, there will be no room left for error or misunderstanding, and troublesome complaints on the part of passengers will be prevented. This method is the rule in stores generally, and it would seem to be a good one for the railroad ticket agent to follow.—*Chicago & North Western Monthly Traffic Bulletin.*

#### Getting Down to Fundamentals.

The Railroad Commission of Louisiana proposes, after giving a public hearing, to take up for adoption the following rule: "All railroads operating in the state of Louisiana shall give all

passenger trains preference over freight trains and shall handle said passenger trains and coaches promptly on their lines, and at all junctions, stations, terminal points and river transfers.

#### Safety First on the Grand Trunk.

The Grand Trunk Railway of Canada has begun a campaign for "Safety First" and has engaged George Bradshaw, formerly of the New York Central, as safety engineer. "Mr. Bradshaw," says the vice-president's circular, "will deliver at all important centers lectures on safety and will illustrate practices responsible for injuries. Notice of the time and place of these lectures will be given, and it is desired that every employee on the system, whose duties permit shall attend. No employee who considers the importance of his personal safety can afford to miss the opportunity which these lectures will afford to learn something of practical value for the protection of his life and limbs.

"We hope to reduce the personal injury record to the lowest possible point and to make our system the safest in the country. To accomplish this every officer, agent and employee is requested to give his earnest and active support and co-operation."

#### Grade Crossing Costs on the New Haven.

The New York, New Haven & Hartford has issued a statement giving a long list of places in Massachusetts, Rhode Island and Connecticut, at which extensive improvements have been made by the company during the past five years, and in Massachusetts alone it appears that the sum of \$4,500,000 has been spent on grade crossing improvements. Thirty-five grade crossings have been abolished within that time. Taunton, Braintree, Worcester and Clinton are among the principal places at which work has been done. Of the cost of the extensive improvements at Worcester, including a union station, the New Haven road pays \$843,515. The line from Boston to Providence is to be electrified and in connection with this work all of the grade crossings will be done away with at a cost of \$1,400,000. The company last year finished the double tracking of its line in western Connecticut, between Hawleyville and Shelton, and in connection with that work abolished 22 grade crossings within 20 miles. New England is a thickly settled territory, and it is doubtful if any other road in the country has abolished grade crossings at so fast a rate.

#### Norfolk & Western Electrification.

The Norfolk and Western has closed a contract with the Westinghouse Electric & Manufacturing Company, Pittsburgh, Pa., to supply all the electrical apparatus required to electrify the road between Bluefield and Vivian, W. Va. The contract calls for 26 130-ton electric locomotives of the single phase-two phase type, together with all necessary power house generating machinery and transmission apparatus.

Single phase alternating current of a frequency of 25 cycles and at 11,000 volts will be supplied to the locomotives through an overhead suspended trolley wire, this system being the same as that in use on the New York, New Haven & Hartford, the Boston & Maine in the Hoosac Tunnel, the Grand Trunk in the Sarnia Tunnel and by the New York, Westchester & Boston. The Bluefield-Vivian Section serves the Pocahontas coal region, and the coal handled amounts to 65,000 tons a day, necessitating trains of 3,250 tons. The maximum grade is two per cent., and at the present three Mallet locomotives are used on each train. Power for the entire electrified section will be generated in a central power house located at Bluestone, W. Va., with an installed capacity of 27,000 k. w. in turbo generators. The traffic conditions of this section of the road are especially well adapted to electrical operation. It is in reality a separate locomotive division at present, and it is claimed it can be operated electrically without affecting the cost of locomotive service on other sections of the road.

#### Howard Elliott to New Haven Stockholders.

"On and after September 1 I shall come to New Haven and take off my coat and go to work. I shall endeavor to perfect an organization, if one does not already exist, that will attend closely to all of the details that are so important to you as owners and to the public that the railroad serves. Little matters

such as those mentioned by our good friend, Mr. Davis, should be attended to, and yet you probably do not realize the enormous amount of detail connected with a road the size of the New York, New Haven & Hartford. The engines of the New Haven every day run 120,000 miles, or five times around the earth. It means a great deal of attention to have every little detail attended to, but we will try to do it and we will try to see that the scrap is picked up and either sold, or, as is sometimes the case, it is cheaper to bury it rather than to pay the labor cost of moving it.

"I listened with great interest to what Mr. Hiller said about the stockholders. I am told there are nearly 25,000 stockholders of this company and they have a duty and they can exert an influence themselves to help the management of this company, because directors and officers of late years have been sorely beset in trying to do their duty to the owners and to the public. We have had to meet rate reductions; we have had to meet increased cost of labor, increased cost of material, and demands from a luxurious people for better facilities.

"The stockholders can do a great deal of good, each one of them in their own circle, in trying to present to their legislators, to their members of congress, to members of commissions and to all who go to work to make the different laws under which the railroad is trying to operate, the stockholders can do good by pointing out that there are two sides to this question and that the side of the stockholders must not be lost sight of in considering the question and in making demands upon the railroad."

#### Safety First on the Erie.

The "Safety-first" idea has become so popular that it appears in a thousand guises, and circulars are literally "too numerous to mention," except as they afford additional useful lessons, or embrace some novelty. From a couple of pages of useful maxims in the *Erie Employees' Magazine*, prepared by E. I. Bowen, superintendent of the Rochester division, we copy such as seem to be out of the usual run:

"Carelessness never won a promotion. A man who has lost interest in his record is worse than useless—he is dangerous.

"When your rule tells you to flag, flag! Remember that many lives are entrusted to your care; you are paid to go back, and there is no possible excuse for not going back. Be sure and go back far enough. It is raining just as hard or it is just as cold twenty feet from the rear of your train as it is back 18 to 35 telegraph poles. When flagging, don't stand near a gang of men at work on track.

"An elderly or feeble person deserves and should have your most careful attention, particularly in getting on or off trains.

"When using step-box, say to each passenger, 'Watch your step' and say it pleasantly.

"Study your time table if you wish to, but don't overlook the fact that your book of rules contains some mighty valuable reading matter.

"Never allow a squirt hose to hang outside of cab, where it might be mistaken for grab iron.

"Don't let the happiness of your own home, that of some fellow-workmen, or that of a patron of the road, be marred by a careless act of yours. The mental agony of a person responsible for injury to another and who escapes to witness the suffering and worry of the unfortunate's dependent ones, is as much to be dreaded as personal injury resulting from such carelessness.

"Your job may not seem worth much to you, but it looks mighty good to the other fellow.

"There will soon be a next accident on the Road. Someone who reads this circular will be concerned as the responsible party or as an innocent sufferer. Do you want it to be you? If not, do your part to avoid it.

"The Safety First habit is first aid to the uninjured.

"The best book on the Safety First Movement, is the Book of Rules."

#### Canadian Rail Production in 1912.

The Bureau of Statistics of the American Iron & Steel Institute, Philadelphia, Pa., has published special statistical bulletin No. 9, giving the statistics of the production of steel ingots and castings and finished rolled forms of iron and steel in the Dominion of Canada in 1912; also statistics for the production of all kinds of pig iron in the first six months of 1913. In 1912 the output of rails amounted to 423,885 tons, or 49.2 per cent.

of the total finished rolled production of iron and steel during the year. In 1911 the output of rails amounted to 360,547 tons, or 46.1 per cent. of the total finished rolled production during that year. The table below gives the production of all kinds of rails from 1895 to 1912. The total for 1899 includes 135 tons of iron rails. Steel rails only were rolled in all years other than 1899.

Years.	Gross tons.	Years.	Gross tons.	Years.	Gross tons.
1895.....	600	1901.....	891	1907.....	311,461
1896.....	600	1902.....	33,950	1908.....	268,692
1897.....	500	1903.....	1,243	1909.....	344,830
1898.....	600	1904.....	36,216	1910.....	366,460
1899.....	835	1905.....	178,885	1911.....	360,547
1900.....	700	1906.....	312,877	1912.....	423,885

#### Citizens' Committee to Finance Chicago Terminal Investigation.

A group of prominent Chicago business men has organized a "Citizens' Terminal Plan Committee" and has announced that it will finance to the extent of \$100,000 a comprehensive study of the Chicago terminal problem, including various plans that have been suggested for new terminal locations. A statement issued by the committee outlines its purposes in part as follows:

"Although Chicago is the greatest railroad center in the world, there has never been a comprehensive study made by a duly qualified and authorized technical commission of its railroad passenger and freight terminal problem in its entirety. As this many sided problem is becoming more and more complicated, it seems to us imperative that such a study be made now, and by a commission of the ablest experts obtainable. We believe that such a broad investigation is needed to supplement the inquiry provided for by the present city council committee on railway terminals.

"We are not committed in favor of or against any of the various terminal plans which have been recently proposed and our only object is that this problem shall be thoroughly, broadly, and constructively investigated, with a view to reaching the best general solution."

As preliminary to the exhaustive investigation and report of the commission, Bion J. Arnold has been engaged to make a study of the terminal proposals of the Pennsylvania and its associated companies, and of various other terminal plans that have been advanced; likewise a study of the report, when made, of the city's expert, John F. Wallace, whose recommendations are expected to receive early attention in the city council. Mr. Arnold is to outline in a general way what should be the principles of an adequate and comprehensive railway terminal plan for the city as a whole; to report as to the extent to which such plans as may be recommended by Mr. Wallace would or would not fit into such a terminal plan for the city as a whole; to report what, if any, modifications of the plans recommended by Mr. Wallace should be made; and why; and to deal with any other matter in his discretion. He is also to report as to the field which should be covered in the comprehensive investigation by the commission of the railroad terminal problem of Chicago.

#### Halifax (N. S.) Ocean Terminals.

The new Halifax Ocean Terminals Railway which is being built to connect the existing main line of the Intercolonial with the proposed new ocean terminals to be constructed near the south end of the Halifax peninsula begins at Bedford basin and then passes under the Halifax & South Western Railway, thence in a southerly direction through the low divide between the basin and the North West Arm until it reaches Chebucto road, which will be crossed overhead. From Chebucto road the line follows the east side of the North West Arm in a southeasterly direction via Maplewood under and to the east of Young avenue. It then proceeds northeasterly crossing over Pleasant street to South and Fawson streets. From the west side of Quinpool road to the east side of Young avenue the railway is carried in a cutting, mostly through rock, and of sufficient depth to pass under all existing roads and streets with very slight alterations. Grade crossings have been entirely eliminated and the location of the railway along the North West arm and across the south end of the peninsula has been determined upon with the greatest care so as to preserve the natural beauty of these suburban and residential districts of the city.

A handsome Union passenger station will be situated near South and Pleasant streets on a site convenient alike to the harbor, business and residential centers of the city.

From Fawson street southward for a distance of about 1¼ miles along the western shore of Halifax harbor the ocean terminals will be constructed. They will provide for a bulkhead passenger landing quay 2,000 ft. long, and five piers each 1,250 ft. long, and 340 ft. broad, the whole protected at the southern end by a breakwater a quarter of a mile long. Ample railway tracks and connections, sheds and equipment, grain elevator, etc., will be provided for the handling of passengers and cargo, and a special feature of the terminals will be the exceptionally good facilities for the handling of passengers, mails and express freight. Extensive immigration quarters will be provided at the passenger landing quay. The quays will provide for depths ranging up to 45 ft., and will therefore be ample for the largest transatlantic liners afloat.

The contract for the grading of the Halifax Ocean Terminals Railway was awarded to the Cook Construction Company and Wheaton Brothers last June, and several of the steam shovels and the heavy plant have arrived, and the work is now proceeding. The railway will be double tracked throughout, and all culverts, bridges and structures will be of permanent construction. The maximum grade is 6/10 per cent., compensated for curvature and the sharpest curve 4 deg.

The contract for the grading includes the construction of a freight terminal yard on an area to be reclaimed from Bedford basin and will extend from Rockingham to Fairview. This contract also includes the construction of the breakwater. Both the terminal yard and breakwater will be constructed with materials excavated from the railway cuttings.

A passenger coach yard with all modern facilities will be provided immediately southwest of the passenger station.

The plans for the first unit of the ocean terminals are being prepared and tenders will be called for at an early date.

Halifax has a splendid geographical and strategical position. It possesses a magnificent, extensive and deep natural harbor perfectly protected, with a short, deep, well lighted and easily navigated entrance channel from the ocean, low range of tide, freedom from tidal currents and silting, and is open all the year round.

When the natural advantages of this harbor are supplemented by the proposed works, Halifax will possess terminal facilities which, although not the largest, will nevertheless equal if not surpass any on the Atlantic coast.

**Indian Railway Tie Supply.**

More than twenty-five per cent. of the surface of India is covered by so-called forests, but as much of this is mere scrub and a great deal is inaccessible, the railways, despite their relatively small mileage, are unable, under existing conditions, to obtain the whole of their wooden tie supply at reasonable rates in the country itself. The reasons for this state of affairs have been well known in India for many years past. To begin with, the native trees do not now yield an adequate supply of suitable timber, and the best local materials for railway work are so much in demand for other purposes that the price has become almost prohibitive in the majority of cases. In the damp climate of Bengal, Australian hardwoods, which have been imported in large quantities, have been found to produce good results, but the forestry service is concentrating its attention on the question of obtaining an adequate supply in the country. Attention is also being paid to the equally important matter of suitable treatment. Metallic ties, which have been extensively adopted, do not give good results on railways running through desert tracts of country, where sand-laden salty winds blow all the year round. Here wooden ties are a necessity. As in other countries, the shortage is due either to the thinning of the wooded areas as the result of unchecked and wasteful tree-felling, or to the absence of systematic reforestation. Timber supplies have been wasted, especially in native states, and trees large enough to cut into ties have become very scarce indeed, with the result that the railways of the country offer a good market for Australian and other hardwoods.

**Car Inspectors' Convention.**

The fourteenth annual convention of the Chief Interchange Car Inspectors' and Car Foremen's Association was held at Minneapolis, Minn., August 26-28, J. L. Stark presiding. The association

was welcomed to the city by the mayor, Wallace G. Nye. Brief addresses were presented by J. L. Stark, T. H. Goodnow, assistant superintendent car department Chicago and North Western, and H. Boutel, chief interchange inspector at Cincinnati, Ohio. The discussions covered the interpretations of the M. C. B. rules of interchange very thoroughly and many points that have been somewhat misunderstood were cleared up, especially those concerning the changes made at the June convention of the M. C. B. Association this year.

The following is a list of the supply companies exhibiting at the convention:

- American Steel Foundries, Chicago, Ill.—Models of the Economy draft arm, Vulcan cast steel brake beam, Vulcan truck, Simplex bolster, Davis wheel and Simplex coupler. Represented by H. J. Melchert and E. Wallers.
- Emery Pneumatic Lubricator Company, St. Louis, Mo.—Brake cylinder lubricant. Represented by E. A. Emery.
- Frost Paint and Manufacturing Company, Minneapolis, Minn.—Waterproof cements for car construction and paints for coal cars and underframes. Represented by S. E. Frost and A. B. Cross.
- Grip Nut Company, Chicago, Ill. Represented by B. C. Hooper and T. P. Swan.
- McCord & Company, Chicago, Ill.—Pinless lid journal box, continuous steel insert in journal box for resisting pedestal wear, locked lid journal box, draft gear swivel yoke, and the yokeless swivel connector draft gear with key attachment. Represented by W. J. Schlacks.
- Mahr Manufacturing Company, Minneapolis, Minn.—The Mahr burner for steel car repairs. Represented by J. A. Mahr and H. H. Warner.
- Standard Heat and Ventilation Company, New York.—Models of the thermo jet, unotherm, train line valve, steam hose coupler, hose clamps and exhaust ventilator. Represented by W. G. Hermeson.
- Templeton, Kenly & Company, Chicago, Ill.—Simplex jacks. Represented by R. Goodell and A. E. Barron.

**Central Railway Club.**

The next regular meeting and fall outing of the Central Railway Club will be held at Buffalo, September 12. Members will go by boat to the Buffalo Launch Club on the Niagara river. The club meeting will be held immediately after arrival at that point. At this meeting J. C. Fritts, master car builder of the Delaware, Lackawanna & Western, will present a paper on Freight Car Troubles.

**MEETINGS AND CONVENTIONS.**

*The following list gives names of secretaries, dates of next or regular meetings, and places of meeting.*

- AIR BRAKE ASSOCIATION.—F. M. Nellis, 53 State St., Boston, Mass.
- AMERICAN ASSOCIATION OF DEMURRAGE OFFICERS.—A. G. Thomson, Boston, Mass. Convention, May 19, 1914, St. Louis.
- AMERICAN ASSOCIATION OF GENERAL PASSENGER AND TICKET AGENTS.—W. C. Hope, New York. Annual meeting, October 14-15, Philadelphia, Pa.
- AMERICAN ASSOCIATION OF FREIGHT AGENTS.—R. O. Wells, East St. Louis, Ill.
- AMERICAN ASSOCIATION OF RAILROAD SUPERINTENDENTS.—E. H. Harman, St. Louis, Mo.; 3d Friday of March and September.
- AMERICAN ELECTRIC RAILWAY ASSOCIATION.—H. C. Donecker, 29 W. 39th St., New York.
- AMERICAN ELECTRIC RAILWAY MANUFACTURERS' ASSOC.—H. G. McConnaughy, 165 Broadway, New York. Meetings with Am. Elec. Ry. Assoc.
- AMERICAN RAILWAY ASSOCIATION.—W. F. Allen, 75 Church St., New York. Next meeting, November 19, 1913, Chicago.
- AMERICAN RAILWAY BRIDGE AND BUILDING ASSOCIATION.—C. A. Lichty, C. & N. W., Chicago. Convention, October 21-24, 1913, Montreal.
- AMERICAN RAILWAY ENGINEERING ASSOCIATION.—E. H. Fritch, 900 S. Michigan Ave., Chicago.
- AMERICAN RAILWAY MASTER MECHANICS' ASSOCIATION.—J. W. Taylor, Old Colony building, Chicago.
- AMERICAN RAILWAY TOOL FOREMEN'S ASSOCIATION.—A. R. Davis, Central of Georgia, Macon, Ga.
- AMERICAN SOCIETY FOR TESTING MATERIALS.—Prof. E. Marburg, University of Pennsylvania, Philadelphia, Pa.
- AMERICAN SOCIETY OF CIVIL ENGINEERS.—C. W. Hunt, 220 W. 57th St., New York; 1st and 3d Wed., except June and August, New York.
- AMERICAN SOCIETY OF ENGINEERING CONTRACTORS.—J. R. Wenlinger, 11 Broadway, New York; 2d Tuesday of each month, New York.
- AMERICAN SOCIETY OF MECHANICAL ENGINEERS.—Calvin W. Rice, 29 W. 39th St., New York.
- AMERICAN WOOD PRESERVERS' ASSOCIATION.—F. J. Angier, B. & O., Baltimore, Md. Next convention, January 20-22, 1914, New Orleans, La.
- ASSOCIATION OF AMERICAN RAILWAY ACCOUNTING OFFICERS.—C. G. Phillips, 143 Dearborn St., Chicago. Annual meeting, May 28, Atlantic City, N. J.
- ASSOCIATION OF RAILWAY CLAIM AGENTS.—J. R. McSherry, C. & E. I., Chicago.
- ASSOCIATION OF RAILWAY ELECTRICAL ENGINEERS.—Jos. A. Andreucetti, C. & N. W. Ry., Chicago. Annual convention, October 18-24, Chicago.
- ASSOCIATION OF RAILWAY TELEGRAPH SUPERINTENDENTS.—P. W. Drew, 112 West Adams St., Chicago.
- ASSOCIATION OF TRANSPORTATION AND CAR ACCOUNTING OFFICERS.—G. P. Conard, 75 Church St., New York.



## Traffic News.

**ASSOCIATION OF WATER LINE ACCOUNTING OFFICERS.**—W. R. Evans, Chamber of Commerce, Buffalo, N. Y. Annual meeting, October 8, Philadelphia, Pa.

**BRIDGE AND BUILDING SUPPLY MEN'S ASSOCIATION.**—H. A. Neally, Joseph Dixon Crucible Co., Jersey City, N. J. Meeting with American Railway Bridge and Building Association.

**CANADIAN RAILWAY CLUB.**—James Powell, Grand Trunk Ry., Montreal, Que.; 2d Tuesday in month, except June, July and August, Montreal.

**CANADIAN SOCIETY OF CIVIL ENGINEERS.**—Clement H. McLeod, 413 Dorchester St., Montreal, Que.; Thursday, Montreal.

**CAR FOREMEN'S ASSOCIATION OF CHICAGO.**—Aaron Kline, 841 North 50th Court, Chicago; 2d Monday in month, Chicago.

**CENTRAL RAILWAY CLUB.**—H. D. Vought, 95 Liberty St., New York; 2d Thurs. in Jan. and 2d Fri. in March, May, Sept., Nov., Buffalo, N. Y.

**CIVIL ENGINEERS SOCIETY OF ST. PAUL.**—L. S. Pomeroy, Old State Capitol building, St. Paul, Minn.; 2d Monday, except June, July, August and September, St. Paul.

**ENGINEERS' SOCIETY OF PENNSYLVANIA.**—E. R. Dasher, Box 704, Harrisburg, Pa.; 1st Monday after 2d Saturday, Harrisburg, Pa.

**ENGINEERS' SOCIETY OF WESTERN PENNSYLVANIA.**—E. K. Hiles, Oliver building, Pittsburgh; 1st and 3d Tuesday, Pittsburgh, Pa.

**FREIGHT CLAIM ASSOCIATION.**—Warren P. Taylor, Richmond, Va.

**GENERAL SUPERINTENDENTS' ASSOCIATION OF CHICAGO.**—E. S. Koller, 226 W. Adams St., Chicago; Wed. preceding 3d Thurs., Chicago.

**INTERNATIONAL RAILWAY CONGRESS.**—Executive Committee, 11, rue de Louvain, Brussels, Belgium. Convention, 1915, Berlin.

**INTERNATIONAL RAILWAY FUEL ASSOCIATION.**—C. G. Hall, 922 McCormick building, Chicago. Annual convention, May 18-22, Chicago.

**INTERNATIONAL RAILWAY GENERAL FOREMEN'S ASSOCIATION.**—Wm. Hall, 829 West Broadway, Winona, Minn.

**INTERNATIONAL RAILROAD MASTER BLACKSMITHS' ASSOCIATION.**—A. L. Woodworth, Lima, Ohio.

**MAINTENANCE OF WAY & MASTER PAINTERS' ASSOCIATION OF THE UNITED STATES AND CANADA.**—W. G. Wilson, Lehigh Valley, Easton, Pa.

**MASTER BOILER MAKERS' ASSOCIATION.**—Harry D. Vought, 95 Liberty St., New York.

**MASTER CAR BUILDERS' ASSOCIATION.**—J. W. Taylor, Old Colony building, Chicago.

**MASTER CAR AND LOCOMOTIVE PAINTERS' ASSOC. OF U. S. AND CANADA.**—A. P. Dane, B. & M., Reading, Mass. Annual meeting, September 9-12, Ottawa, Can.

**NATIONAL RAILWAY APPLIANCE ASSOC.**—Bruce V. Crandall, 537 So. Dearborn St., Chicago. Meetings with Am. Ry. Eng. Assoc.

**NEW ENGLAND RAILROAD CLUB.**—W. E. Cade, Jr., 683 Atlantic Ave., Boston, Mass.; 2d Tuesday in month, except June, July, Aug. and Sept., Boston.

**NEW YORK RAILROAD CLUB.**—H. D. Vought, 95 Liberty St., New York; 3rd Friday in month, except June, July and August, New York.

**NORTHERN RAILROAD CLUB.**—C. L. Kennedy, C., M. & St. P., Duluth, Minn.; 4th Saturday, Duluth.

**PEORIA ASSOCIATION OF RAILROAD OFFICERS.**—M. W. Rothford, Union Station, Peoria; 2d Thursday.

**RAILROAD CLUB OF KANSAS CITY.**—C. Manlove, 1008 Walnut St., Kansas City, Mo.; 3d Friday in month, Kansas City.

**RAILWAY BUSINESS ASSOCIATION.**—Frank W. Noxon, 2 Rector St., New York. Annual dinner, second week in December, 1913, New York.

**RAILWAY CLUB OF PITTSBURGH.**—J. B. Anderson, Penna. R. R., Pittsburgh, Pa.; 4th Friday in month, except June, July and August, Pittsburgh.

**RAILWAY ELECTRICAL SUPPLY MANUFACTURERS' ASSOC.**—J. Scribner, 1021 Monadnock Block, Chicago. Meetings with Assoc. Ry. Elec. Engrs.

**RAILWAY FIRE PROTECTION ASSOCIATION.**—C. B. Edwards, Mobile & Ohio, Mobile, Ala. Next meeting, October 7, Chicago.

**RAILWAY GARDENING ASSOCIATION.**—J. S. Butterfield, Lee's Summit, Mo.

**RAILWAY DEVELOPMENT ASSOCIATION.**—W. Nicholson, Kansas City Southern, Kansas City, Mo.

**RAILWAY SIGNAL ASSOCIATION.**—C. C. Rosenberg, Bethlehem, Pa. Convention, October 14, Nashville, Tenn.

**RAILWAY STOREKEEPERS' ASSOCIATION.**—J. P. Murphy, Box C, Collinwood, Ohio.

**RAILWAY SUPPLY MANUFACTURERS' ASSOC.**—J. D. Conway, 2135 Oliver bldg., Pittsburgh, Pa. Meetings with M. M. and M. C. B. Assocs.

**RAILWAY TEL. AND TEL. APPLIANCE ASSOC.**—W. E. Harkness, 284 Pearl St., New York. Meetings with Assoc. of Ry. Teleg. Sups.

**RICHMOND RAILROAD CLUB.**—F. O. Robinson, Richmond, Va.; 2d Monday except June, July and August.

**ROADMASTERS' AND MAINTENANCE OF WAY ASSOCIATION.**—L. C. Ryan, C. & N. W., Sterling, Ill. Convention, September 8-12, 1913, Chicago.

**ST. LOUIS RAILWAY CLUB.**—B. W. Frauenthal, Union Station, St. Louis, Mo.; 2d Friday in month, except June, July and Aug., St. Louis.

**SIGNAL APPLIANCE ASSOCIATION.**—F. W. Edmonds, 3868 Park Ave., New York. Meeting with annual convention Railway Signal Association.

**SOCIETY OF RAILWAY FINANCIAL OFFICERS.**—C. Nyquist, La Salle St. Station, Chicago. Annual meeting, September 23-25, Chicago.

**SOUTHERN ASSOCIATION OF CAR SERVICE OFFICERS.**—E. W. Sandwich, A. & W. P. Ry., Montgomery, Ala.

**SOUTHERN & SOUTHWESTERN RAILWAY CLUB.**—A. J. Merrill, Grant bldg., Atlanta, Ga.; 3d Thurs., Jan., March, May, July, Sept., Nov., Atlanta.

**TOLEDO TRANSPORTATION CLUB.**—J. G. Macomber, Woolson Spice Co., Toledo, Ohio; 1st Saturday, Toledo.

**TRACK SUPPLY ASSOCIATION.**—W. C. Kidd, Ramapo Iron Works, Hillsburn, N. Y. Meeting with Roadmasters' and Maintenance of Way Association.

**TRAFFIC CLUB OF CHICAGO.**—W. H. Wharton, La Salle Hotel, Chicago.

**TRAFFIC CLUB OF NEW YORK.**—C. A. Swope, 290 Broadway, New York; last Tuesday in month, except June, July and August, New York.

**TRAFFIC CLUB OF PITTSBURGH.**—D. L. Wells, Erie, Pittsburgh, Pa.; meetings monthly, Pittsburgh.

**TRAFFIC CLUB OF ST. LOUIS.**—A. F. Versen, Mercantile Library building, St. Louis, Mo. Annual meeting in November. Noonday meetings October to May.

**TRAIN DISPATCHERS' ASSOCIATION OF AMERICA.**—J. F. Mackie, 7042 Stewart Ave., Chicago.

**TRANSPORTATION CLUB OF BUFFALO.**—J. M. Sells, Buffalo; first Saturday after first Wednesday.

**TRANSPORTATION CLUB OF DETROIT.**—W. R. Hurley, L. S. & M. S., Detroit, Mich.; meetings monthly.

**TRAVELING ENGINEERS' ASSOCIATION.**—W. O. Thompson, N. Y. C. & H. R., East Buffalo, N. Y.

**UTAH SOCIETY OF ENGINEERS.**—Fred D. Ulmer, Oregon Short Line, Salt Lake City, Utah; 3d Friday of each month, except July and August.

**WESTERN CANADA RAILWAY CLUB.**—W. H. Rosevear, P. O. Box 1707, Winnipeg, Man.; 2d Monday, except June, July and August, Winnipeg.

**WESTERN RAILWAY CLUB.**—J. W. Taylor, Old Colony building, Chicago; 3d Tuesday of each month, except June, July and August.

**WESTERN SOCIETY OF ENGINEERS.**—J. H. Warder, 1735 Monadnock Block, Chicago; 1st Monday in month, except July and August, Chicago.

The Maine Central announces that, beginning with September 1, 500-mile tickets will be sold in the State of Maine at \$11.25, or 2¼ cents a mile.

The quarterly meeting of the Erie Railroad Freight Agents' Association was held at the Great Northern Hotel, Chicago, on August 21, with over 100 in attendance.

At Clayton, Del., the agent of the Adams Express Company has been arrested on a charge of violating the law of Delaware, forbidding the shipping of intoxicating liquors.

The New York, New Haven & Hartford expects to transport soon from southeastern Massachusetts about 1,500 carloads of cranberries. The cranberry farmers expect the largest crop on record.

A single shipment recently sent out from Youngstown, Ohio, destined to Newcastle, New South Wales, is reported to have filled 45 cars. It was material for a complete blast furnace, made by the Pollock Company.

The Union Pacific has announced that the American Express Company has been appointed passenger agent of the system in important cities of Europe. The American Express Company already represents in a somewhat similar capacity the New York Central Lines.

The Erie has extended its freight service in Chicago, both all-rail and lake-and-rail, to several stations on the Chicago River at Erie street, Market square, between Washington and Randolph streets, and Twenty-seventh and Robey streets, cars being taken to and from the new stations on car floats. A station at Webster avenue will be established later.

Through service between eastern and western Canada is now in effect over the Grand Trunk Railway system, in connection with the Northern Navigation Company, the route being westward over the Grand Trunk to Sarnia, the Northern Navigation Company to Fort William and the Grand Trunk Pacific to Winnipeg and points in western Canada. The summer schedule in effect over this route provides service three days a week in each direction.

The secretary of agriculture has issued a circular, No. 199, dated August 14, making changes, to take effect September 1, in the areas quarantined for Texas fever in cattle, considerable territories being released from quarantine in Texas, Oklahoma, Tennessee, Georgia and South Carolina. By the same order provision is made for transporting cattle to be exhibited at fairs in Alabama, Oklahoma, Mississippi, Virginia, Georgia, Arkansas and Texas.

The Ward Line, carrying freight to Gulf of Mexico points, announces that the suspension of through freight rates, ordered by the Mexican government some weeks ago, has been abrogated, and that shipments will now be made under tariff 3C, as formerly. It appears that the notice issued by the National Railways of Mexico, discontinuing through rates, was made necessary by an order of the authorities in Mexico, requiring freight rates to be quoted in Mexican currency, as well as to be printed in the Spanish language. The fluctuations in the value of Mexican currency made it impossible for lines in this country to adjust the tariffs as required by the order.

### Car Surpluses and Shortages.

Arthur Hale, chairman of the committee on relations between railroads of the American Railway Association, in presenting statistical bulletin No. 149-A, giving a summary of car surpluses and shortages by groups from May 9, 1912, to August 15, 1913, says: The total surplus on August 15, 1913, was 69,253 cars; on August 1, 1913, 69,716 cars; and on August 15, 1912, 58,623 cars. Compared with the preceding period; there is a decrease in the total surplus of 463 cars, made up as follows: An increase of 3,083 in box, 163 in flat, and a decrease of 517 in coal, and 3,192 in miscellaneous car surplus. The increase in box car surplus is in groups 1 (New England lines), 4 (the Virginias and Carolinas), 5 (Kentucky, Tennessee, Mis-

Mississippi, Alabama, Georgia and Florida), 6 (Iowa, Illinois, Wisconsin and Minnesota), 8 (Kansas, Colorado, Oklahoma, Missouri and Arkansas), 10 (Washington, Oregon, Idaho, California, Nevada and Arizona), and 11 (Canadian lines). The increase in flat car surplus is in all groups, except 2, 7 and 9 (as above). The decrease in miscellaneous car surplus is in all groups, except 2, 7 and 10 (as above).

The total shortage on August 15, 1913, was 14,828 cars; on August 1, 1913, 11,261 cars; and on August 15, 1912, 14,722 cars. Compared with the preceding period; there is an increase in the total shortage of 3,567 cars, of which 127 is in box, 414 in flat, 3,009 in coal and 17 in miscellaneous car short-

age. The increase in box car shortage is in all groups, except 7, 8 and 9 (as above). The increase in flat car shortage is in groups 2 (as above), 3 (Ohio, Indiana, Michigan and western Pennsylvania), 4, 5 and 6 (as above). The increase in coal car shortage is in all groups, except 6 and 9 (as above). The increase in miscellaneous car shortage is in groups 1, 3, 5, 6, 10 and 11 (as above).

Compared with the same date of 1912; there is an increase in the total surplus of 10,630 cars, of which 8,197 is in box, 650 in flat, 3,148 in miscellaneous, and a decrease of 1,365 in coal car surplus. There is an increase in the total shortage of 106 cars, made up as follows: An increase of 2,335 in coal, and a decrease of 697 in box, 812 in flat and 720 in miscellaneous car shortage.

The accompanying table gives car surplus and shortages figures by groups for the last period covered in the report and

CAR SURPLUSES AND SHORTAGES.

Date.	No. of roads.	Surpluses				Shortages					
		Box.	Flat.	Coal, gondola and hopper.	Other kinds.	Total.	Box.	Flat.	Coal, gondola and hopper.	Other kinds.	Total.
Group *1.—August 15, 1913.....	7	1,201	159	10	100	1,470	69	34	185	5	293
" 2.—" 15, 1913.....	33	505	78	1,789	834	3,206	165	3	693	0	861
" 3.—" 15, 1913.....	32	2,261	259	200	1,719	4,439	610	294	2,152	135	3,191
" 4.—" 15, 1913.....	16	3,845	692	674	447	5,658	704	422	2,490	0	3,616
" 5.—" 15, 1913.....	26	627	10	125	455	1,217	485	525	916	10	1,936
" 6.—" 15, 1913.....	31	8,436	147	1,345	3,839	13,767	1,265	32	126	9	1,432
" 7.—" 15, 1913.....	5	76	24	300	180	580	638	0	0	0	638
" 8.—" 15, 1913.....	20	3,210	86	1,833	3,466	8,595	417	88	339	17	861
" 9.—" 15, 1913.....	14	957	351	265	690	2,263	100	0	0	0	100
" 10.—" 15, 1913.....	21	3,883	928	1,752	8,869	15,432	384	1	137	117	639
" 11.—" 15, 1913.....	6	10,755	217	0	1,654	12,626	879	347	0	35	1,261
Total .....	211	35,756	2,951	8,293	22,253	69,253	5,716	1,746	7,038	328	14,828

\*Group 1 is composed of New England lines; Group 2—New York, New Jersey, Delaware, Maryland and Eastern Pennsylvania lines; Group 3—Ohio, Indiana, Michigan and Western Pennsylvania lines; Group 4—West Virginia, Virginia, North and South Carolina lines; Group 5—Kentucky, Tennessee, Mississippi, Alabama, Georgia and Florida lines; Group 6—Iowa, Illinois, Wisconsin and Minnesota lines; Group 7—Montana, Wyoming, Nebraska, North Dakota and South Dakota lines; Group 8—Kansas, Colorado, Missouri, Arkansas and Oklahoma lines; Group 9—Texas, Louisiana and New Mexico lines; Group 10—Washington, Oregon, Idaho, California, Nevada and Arizona lines; Group 11—Canadian lines.

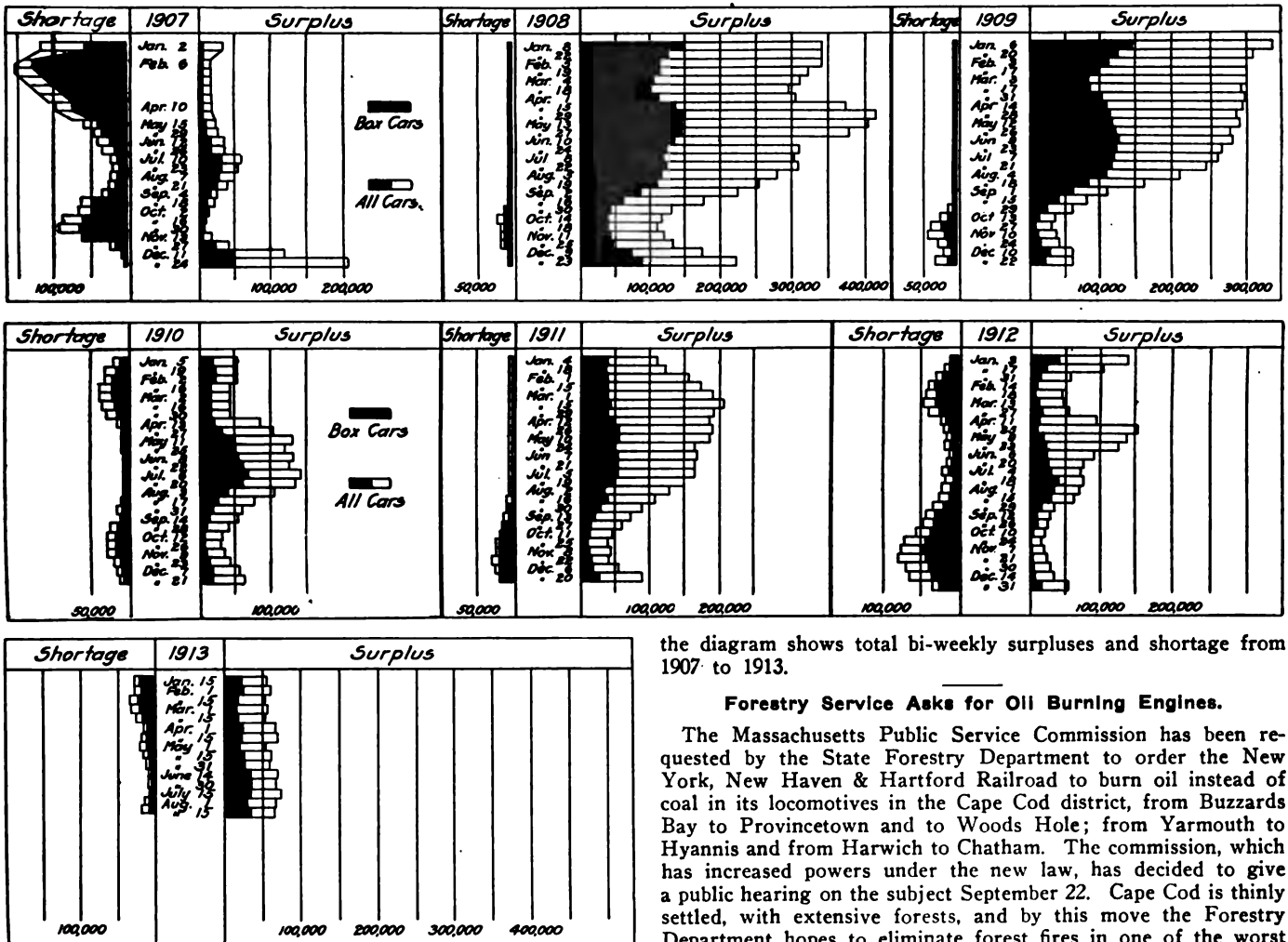

Car Surpluses and Shortages, 1907 to 1913.

the diagram shows total bi-weekly surpluses and shortage from 1907 to 1913.

**Forestry Service Asks for Oil Burning Engines.**

The Massachusetts Public Service Commission has been requested by the State Forestry Department to order the New York, New Haven & Hartford Railroad to burn oil instead of coal in its locomotives in the Cape Cod district, from Buzzards Bay to Provincetown and to Woods Hole; from Yarmouth to Hyannis and from Harwich to Chatham. The commission, which has increased powers under the new law, has decided to give a public hearing on the subject September 22. Cape Cod is thinly settled, with extensive forests, and by this move the Forestry Department hopes to eliminate forest fires in one of the worst fire hazard districts of the state.

**Revenues and Expenses of Large Roads for June.**

The following figures were compiled by the Interstate Commerce Commission from monthly reports of operating revenues and expenses of large steam roads for the month of June, 1913, received up to August 22. No reports are included for roads whose operating revenues for the year ended June 30, 1912, did not reach \$1,000,000. The figures are compiled as rendered and should not be considered final, inasmuch as scrutiny of the reports may lead to their modification before acceptance.

the Mississippi river. The commission decided that ordinarily the through rate is and should be less than the sums of the intermediates, for the reason that the cost of the through movement is less; and the present instance is no exception to this rule.

It is a fundamental maxim of rate making that the rate per ton-mile shall decrease as the distance increases, but it is not a rule of such universal or imperative application that every shipper is entitled to the benefit of it, nor can it be said that to disregard this rule creates of necessity a discrimination.

Item.	REVENUES AND EXPENSES OF LARGE STEAM ROADS.											
	United States.		Eastern District.		Southern District.		Western District.					
	1913.	1912.	1913.	1912.	1913.	1912.	1913.	1912.	1913.	1912.	1913.	1912.
Number of reports included...	159		62		32		65					
	MONTH OF JUNE.											
Average number of miles operated	204,449.98	202,260.26	52,008.61	51,681.02	39,087.50	38,958.25	113,353.87	111,620.99				
Total operating revenues	\$234,990,854	\$219,631,031	\$105,213,948	\$99,134,288	\$34,670,094	\$32,691,347	\$95,106,812	\$87,805,395				
Total operating expenses	165,237,401	149,197,388	75,336,571	66,176,078	25,506,495	23,726,954	64,394,335	59,294,355				
Net operating revenue	69,753,453	70,433,643	29,877,377	32,958,210	9,163,599	8,964,393	30,712,477	28,511,040				
Revenues per mile	1,149	1,086	2,023	1,918	887	839	839	787				
Expenses per mile	808	738	1,449	1,280	653	609	568	531				
Net revenue per mile	341	348	574	638	234	230	271	256				
Average number of miles operated	203,695.68	200,986.39	51,853.16	51,538.81	39,060.56	38,748.57	112,781.96	110,699.01				
Total operating revenues	\$2,823,555,873	\$2,548,782,711	\$1,224,583,619	\$1,102,126,326	\$434,811,410	\$403,284,513	\$1,164,160,844	\$1,043,371,872				
Total operating expenses	1,950,334,155	1,755,940,392	874,159,449	774,160,864	311,608,713	286,409,876	764,565,993	695,369,652				
Net operating revenue	873,221,718	792,842,319	350,424,170	327,965,462	123,202,697	116,874,637	399,594,851	348,002,220				
Revenues per mile	13,861	12,681	23,616	21,384	11,132	10,408	10,322	9,425				
Expenses per mile	9,575	8,737	16,858	15,021	7,978	7,392	6,779	6,281				
Net revenue per mile	4,286	3,944	6,758	6,363	3,154	3,016	3,543	3,144				

**COMPARATIVE FIGURES BASED ON ALL ROADS HAVING REVENUES ABOVE \$1,000,000 PER ANNUM REPORTING FOR JUNE, 1912.**

	1912.	1911.
For June—		
Average number of miles operated	219,626.05	217,115.20
Revenues per mile	\$1,078	\$1,028
Expenses per mile	738	704
Net revenue per mile	340	324
For Twelve Months—		
Average number of miles operated	219,372.89	216,194.00
Revenues per mile	\$12,601	\$12,547
Expenses per mile	8,708	8,603
Net revenue per mile	3,893	3,944

The complainants do not make out an undue discrimination, but they show rather an unnatural and an unreasonable rate condition. Balancing the effect upon the carriers by reduction in revenues which must ensue upon a removal of this complaint against the slight benefit which would accrue to complainants, the commission is of the opinion that no action should be taken now. (28 I. C. C., 230.)

**STATE COMMISSIONS.**

George P. Lawrence, a member of the recently established Public Service Commission of Massachusetts, has resigned.

The Public Service Commission of Missouri consists of the following gentlemen: John M. Atkinson (chairman), Wm. F.

**Car Location.**

The accompanying table, which was taken from bulletin No. 9 of the American Railway Association, gives a summary of freight car location by groups on August 1, 1913.

	CAR LOCATION ON AUGUST 1, 1913.											
	New England.	N. Y., N. J., Del., Md., Pa.	Ohio, Mich., W. Va.	Ind., Pa.	Ill., W. Va., No. & So. Carolina.	Ky., Tenn., Miss., Ala., Ga., Fla.	Iowa, Wyo., Minn.	Mont., Neb., Dakotas.	Kans., Colo., Okla., Mo., Ark.	Texas, La., New Mexico.	Oregon, Idaho, Nev., Cal., Ariz.	Canadian Lines.
Total Cars Owned	89,899	679,355	281,468	201,442	168,910	481,064	17,252	153,154	29,704	131,765	137,316	2,371,329
Home Cars on Home Roads	46,864	402,362	114,890	105,544	87,946	336,850	5,772	83,538	14,519	77,588	95,446	1,371,319
Home Cars on Foreign Roads	43,035	276,993	166,578	95,898	80,964	144,214	11,480	69,616	15,185	54,177	41,870	1,000,010
Foreign Cars on Home Roads	46,920	284,764	207,587	74,373	62,519	179,419	8,954	70,457	23,667	51,399	44,113	1,054,172
Total Cars on Line	93,784	687,126	322,477	179,917	150,465	516,269	14,726	153,995	38,186	128,987	139,559	2,425,491
Excess or Deficiency	3,885	7,771	41,009	*21,525	*18,445	35,205	*2,526	841	8,482	*2,778	2,243	54,162
Surplus	1,484	9,182	1,263	4,232	1,208	12,192	473	9,583	2,240	15,320	12,539	69,716
Shortage	228	538	1,687	2,568	849	1,380	831	1,203	661	505	811	11,261
Shop Cars—												
Home Cars in Home Shops	6,125	40,342	22,369	13,469	15,164	25,687	672	11,316	2,469	5,322	4,572	147,507
Foreign Cars in Home Shops	1,274	8,858	7,747	2,186	1,986	4,727	525	2,154	847	2,366	488	33,158
Total Cars in Shops	7,399	49,200	30,116	15,655	17,150	30,414	1,197	13,470	3,316	7,688	5,060	180,665
Per Cent. to Total Cars Owned—												
Home Cars on Home Roads	52.13	59.23	40.88	52.39	52.07	70.02	33.46	54.55	48.88	58.88	69.51	57.83
Total Cars on Line	101.63	101.14	114.48	89.31	89.08	107.32	85.36	99.28	128.56	97.89	101.63	102.28
Home Cars in Home Shops	6.81	5.94	7.95	6.69	8.98	5.69	3.90	7.39	8.31	4.04	3.33	6.30
Foreign Cars in Home Shops	1.07	1.30	2.75	1.08	1.17	1.05	3.04	1.29	2.85	1.79	.35	1.42
Total Cars in Shops	7.88	7.24	10.70	7.77	10.15	6.74	6.94	8.68	11.16	5.83	3.68	7.72

\*Denotes deficiency.

**INTERSTATE COMMERCE COMMISSION.**

The Houston Chamber of Commerce has filed a complaint with the Interstate Commerce Commission against 18 railways, attacking class and commodity rates from Houston, Tex., to points in Arkansas as unreasonable in comparison with rates from St. Louis, Kansas City and New Orleans to the same points.

**Complaint Dismissed.**

*Boston Chamber of Commerce et al. v. Atchison, Topeka & Santa Fe et al. Opinion by Commissioner Prouty:*

The complainants ask that rates from the Atlantic seaboard to Colorado and Utah common points be so adjusted that the through rate will be less than the combination upon Chicago or

Woerner, John Kennish, Howard B. Shaw and Frank A. Wightman. The secretary of the commission is T. M. Bradbury; office at Jefferson City.

The Board of Public Utility Commissioners of New Jersey, acting on a complaint of a number of shippers; has forbidden an increase in freight rates which has been announced by the Morristown & Erie on shipments to points on the Delaware, Lackawanna & Western. The Morristown & Erie extends west from the western terminus of the Caldwell branch of the Erie Railroad, and connects with the Lackawanna at Morristown. The advance in rates was made in the shape of a notice discontinuing existing through rates, making necessary a combination of local rates for the shipments which are the subject of complaint.

## Railway Officers.

### Executive, Financial and Legal Officers.

H. A. Scandrett, interstate commerce attorney of the Union Pacific system, has moved his office from Omaha to Chicago.

Mrs. Cora B. Williams, of Atlanta, Ga., has been elected president of the Georgia, Florida & Alabama, succeeding her late husband, J. P. Williams, deceased.

James H. Hustis, vice-president of the Boston & Albany, has been elected vice-president of the New York, New Haven & Hartford, in charge of all departments, with headquarters at New Haven, Conn., effective September 1, and as soon as the by-laws of the company are amended so that Howard Elliott becomes chairman of the board, Mr. Hustis will succeed him as president of the New Haven. It is understood that this will take effect about November 1, as was noted in an article containing a portrait and sketch of Mr. Hustis in these columns on August 1, page 179.

George Theron Slade, who recently was elected first vice-president of the Northern Pacific, with office at St. Paul, Minn., was born July 22, 1871, in New York City. He was graduated from Yale University, class of 1893, and entered railway service that year with the Great Northern as a clerk. He was successively timekeeper and assistant roadmaster until August, 1895, when he was made chief clerk to the superintendent of the Eastern Railway of Minnesota. In September of the following year he was advanced to assistant superintendent and one year later was appointed superintendent of that road and the Duluth Terminal Railway. In November, 1899, he became general manager of the Erie & Wyoming Valley and the Delaware Valley & Kingston, which position he held until March, 1901, when he was made superintendent of the Wyoming and Jefferson divisions of the Erie. Five months later he was promoted to the general superintendency of the Erie division of that road, resigning April 1, 1903, to go to the Great Northern as general superintendent. Mr. Slade left the Great Northern in 1907 to accept the position of general manager of the Northern Pacific, and in 1910 he was chosen third vice-president of that road, and on August 27, he was elected first vice-president, as above noted.

### Operating Officers.

W. J. Helmick has been appointed superintendent of the Gulf, Texas & Western, with headquarters at Jermyn, Tex.

P. G. Walton has resigned as assistant superintendent of the St. Louis, Brownsville & Mexico to go to the Pere Marquette.

W. S. Martin, assistant general manager of the Denver & Rio Grande, has been appointed general manager, with headquarters at Denver, Col.

E. O. McGrain, assistant general yardmaster of the Western Maryland, at Cumberland, Md., has been appointed general yardmaster of the Baltimore terminals, with headquarters at Hillen Station.

Frederick Hanssen, inspector of train service in the office of W. R. Scott, general manager of the Southern Pacific, has been appointed assistant superintendent of the Portland division at Portland, Ore.

M. C. Sullivan has been appointed assistant superintendent of the Texas & New Orleans and assistant division superintendent of the Galveston, Harrisburg & San Antonio, with headquarters at Houston, Tex., in place of W. Bretschneider, who has been granted a leave of absence.

R. E. Clarke, superintendent of car service of the Beaumont, Sour Lake & Western, the New Orleans, Texas & Mexico, Orange & Northwestern and St. Louis, Brownsville & Mexico, has been appointed superintendent of car service of those roads, with headquarters at Houston, Tex., and the former position is abolished.

The authority of J. W. Farrell, trainmaster of the Grand Trunk, has been extended to include the Third district, and the headquarters for trainmaster of Second and Third districts will hereafter be at Richmond, Que. T. Cushing, trainmaster at

Richmond, has been assigned to other duties, and T. H. Mason has been appointed trainmaster of the Fourth district, succeeding A. D. McCarthy, resigned.

Maurice A. Neville, who recently was appointed general superintendent of the Cincinnati Northern, as previously stated in these columns, was born October 9, 1877, at London, Ohio. He was educated at the University of Notre Dame, Notre Dame, Ind., 1894 to 1899, and began railway work in June, 1899, with the Peoria & Eastern as engineer on corps. In October of that year he was made assistant engineer, and in March, 1901, was promoted to engineer maintenance of way. He was made superintendent in August, 1903, which position he held until his recent appointment as general superintendent of the Cincinnati Northern, with headquarters at Van Wert, Ohio, as above noted.

C. C. Walker, general superintendent of transportation of the Chesapeake & Ohio at Richmond, Va., has been appointed assistant to general manager, with office at Richmond. E. P. Goodwin, general inspector of transportation at Richmond, has been appointed superintendent of transportation, with office at Richmond. J. W. Knapp, general superintendent of the Virginia general division at Richmond, becomes superintendent of the Newport News terminals, with office at Newport News. J. P. Stevens, general superintendent of the Kentucky general division at Cincinnati, Ohio, has been appointed general superintendent of the Virginia general division, with office at Richmond. W. R. Hudson, general superintendent at Peru, Ind., has been appointed general superintendent of the Kentucky general division and the Chesapeake & Ohio of Indiana, with office at Covington, Ky. W. L. Booth, superintendent of the Ashland division, at Ashland, Ky., has been appointed superintendent of the Chesapeake & Ohio of Indiana, with office at Peru, Ind. H. H. Morris, superintendent of the Richmond division at Richmond, succeeds Mr. Booth, and E. I. Ford, superintendent of terminals at Newport News, succeeds Mr. Morris. Effective September 1.

### Traffic Officers.

Zack J. Reese, baggage agent of the Texas & Pacific at Dallas, Tex., has been appointed general baggage agent of that system, with headquarters at Dallas.

Charles Elliott, city passenger agent of the Western Maryland at Baltimore, Md., has been appointed to the new position of general baggage agent, with headquarters at Baltimore. R. H. Lewis, formerly in the office of the division passenger agent of the Pennsylvania Railroad, at Baltimore, succeeds Mr. Elliott.

George C. Kelleher, chief rate clerk of the New Orleans & Northeastern, has been appointed assistant general passenger agent of the New Orleans & Northeastern, the Alabama & Vicksburg and the Vicksburg, Shreveport & Pacific, with headquarters at New Orleans, La., succeeding R. J. Anderson, resigned to go into other business.

### Engineering and Rolling Stock Officers.

W. F. Howard has been appointed general foreman of the Gulf, Colorado & Santa Fe at Cleburne, Tex., succeeding A. B. Adams, promoted.

J. L. Taylor has been appointed assistant division engineer of the Pittsburgh, Cincinnati, Chicago & St. Louis, with office at Louisville, Ky., succeeding H. J. Shaw, transferred.

T. Keaveny has been appointed roadmaster of the Second district of the Oregon-Washington Railroad & Navigation Company, Fourth division, with headquarters at Colfax, Wash., succeeding J. L. Twyman, transferred.

G. M. Crownover, master mechanic of the Chicago Great Western at Oelwein, Iowa, has been appointed superintendent of motive power, with office at Oelwein, succeeding J. G. Neuffer, resigned to retire from railway service, effective September 1.

C. H. Sanderson, engineer of switchboard and power station design for the Westinghouse Electric Manufacturing Company at East Pittsburgh, Pa., has been appointed chief engineer of the Havana Electric Railway Light & Power Company, with headquarters at Havana, Cuba.

J. E. McQuillen, whose appointment as mechanical superintendent of the Gulf, Colorado & Santa Fe, with headquarters at Cleburne, Tex., has already been announced in these columns,

was born at Rochester, N. Y., January 25, 1873. He was educated in the public schools of Rochester and at the Sacred Heart Academy at Palestine, Tex., and began railway work in October, 1887, as roundhouse caller for the International & Great Northern at Palestine, being employed in that capacity until February, 1888, from which time until April, 1892, he was a machinist apprentice. He was then until October, 1895, machinist and foreman in various railroad and contract shops in the United States and Mexico, on the latter date being appointed general foreman of the Houston East & West Texas at Houston, Tex. From January, 1897, to June, 1901, he was a machinist and division foreman in the shops of the International & Great Northern at Taylor, Tex., and the following three months was with the Missouri, Kansas & Texas at Smithville, Tex., as a machinist. Mr. McQuillen went to the Gulf, Colorado & Santa Fe in September, 1901, and until December, 1902, was machinist and roundhouse gang boss at Temple, Tex. He was then made general foreman at Gainesville, Tex., and in November, 1906, was promoted to master mechanic at Silsbee, Tex., which position he held until his recent appointment as mechanical superintendent, as above noted.

#### Purchasing Officers.

Thomas Spratt, who has been appointed assistant purchasing agent of the Norfolk & Western, with headquarters at Roanoke, Va., as has been announced in these columns, was born on June 3, 1865, at Philadelphia, Pa., and was educated in the public schools of his native town. He began railway work on June 1, 1886, as clerk in the purchasing agent's office of the Norfolk & Western, and in June, 1901, was made stationer. In September, 1903, he became chief clerk to the purchasing agent, which position he held at the time of his recent appointment as assistant purchasing agent of the same road, as above noted.

George Edwin McWhite, whose appointment as assistant purchasing agent of the Atlanta, Birmingham & Atlantic, with headquarters at Atlanta, Ga., has been announced in these columns, was born on March 8, 1885, and was educated in the high schools. He began railway work on July 11, 1905, in the engineering department of the Atlantic Coast Line, and left that company the following January to go in the purchasing department of the Atlanta, Birmingham & Atlantic. He has been in the continuous service of that road ever since, and was chief clerk of the purchasing department at the time of his recent appointment as assistant purchasing agent.

#### OBITUARY.

Herman Silver, formerly receiver of the Los Angeles & Pacific, died on August 19 at Los Angeles, Cal., aged 82 years.

George L. Irwin, formerly a division superintendent of the Chicago & North Western, died on August 22 at his residence in Chicago, aged 83 years.

George W. Crary, treasurer of the New Orleans, Mobile & Chicago, at Mobile, Ala., died in that city recently. Mr. Crary was born in Cincinnati, Ohio. He was secretary and treasurer of the Mobile, Jackson & Kansas City, and when that company was reorganized under the name of the New Orleans, Mobile & Chicago in 1909, he retained the same position; but since January, 1912, he has been treasurer only.

William Carpenter Smith, chief engineer maintenance of way of the Northern Pacific at St. Paul, Minn., died in that city on August 26. He was born on July 30, 1865, at St. Cloud, Minn., and graduated from the civil engineering department of the Minnesota State University in June, 1890. The same year he began railway work as resident engineer on the St. Paul & Northern Pacific, and three years later he was appointed assistant engineer at Duluth, Minn., of its successor, the Northern Pacific, and has been in the continuous service of that road ever since. He was transferred in 1897 in the same capacity to Jamestown, N. D., and from 1899, to March, 1902, was assistant engineer in charge of construction work. In March, 1902, he was appointed division engineer at Livingston, Mont., and the following December was transferred in the same capacity to St. Paul, Minn., remaining in that position until March, 1907, when he was made engineer maintenance of way, and since February 7, 1910, was chief engineer maintenance of way of the same road.

## Equipment and Supplies.

### LOCOMOTIVE BUILDING.

THE KOREAN GOVERNMENT RAILWAYS have ordered 6 Pacific type locomotives from the Baldwin Locomotive Works.

THE CZARNIKOW RIONDA COMPANY, New York, has ordered 1 consolidation locomotive from the Baldwin Locomotive Works.

THE BRAZIL NORTHEASTERN has ordered 4 ten-wheel locomotives and 3 consolidation locomotives from the Baldwin Locomotive Works.

THE WISCONSIN & NORTHERN has ordered 1 ten-wheel locomotive from the American Locomotive Company. The dimensions of the cylinders will be 19½ x 26 in., the diameter of the driving wheels will be 63 in., and the total weight in working order will be 165,000 lbs.

### IRON AND STEEL.

THE NORTHERN PACIFIC is in the market for 3,400 tons of structural steel.

THE NEW YORK CENTRAL LINES will soon be in the market for about 125,000 tons of rails.

THE CHICAGO & ALTON has ordered 2,000 tons of structural steel from the American Bridge Company.

GENERAL CONDITIONS IN STEEL.—During the past week there has been an improvement in buying movement. The demand for the lighter products is more pronounced than for the heavier grades of steel. The month of September is expected to mark the beginning of a considerable improvement in the buying movement on the part of the railroads. A number of roads are now figuring on heavy rail orders for 1914 requirements, and it is expected that some of these orders will be placed in the near future. Steel manufacturers also believe that orders for rolling stock will show material increases during the next few months.

INDIAN RAILWAY IMPROVEMENTS.—Some modest schemes are in contemplation for the improvement of communications within the native states of Jodhpur and Bikanir. The idea seems to be to convert that portion of the Jodhpur-Bikanir Railway which lies between Kuchwan Road and Hyderabad to broad gage, with certain additions on 3 ft. 3 in. gage as feeders.

NEW SOUTH WALES ENGINE ORDER.—The Government of New South Wales has placed orders for 80 new locomotives for the State railways. The North British Locomotive Company, Ltd., of Glasgow, Scotland, is to supply 50 and the Manchester, England, firm of Beyer, Peacock & Company, Ltd., the remaining 30. The former must deliver within five months, ready for shipment at Glasgow, four engines, and thereafter six each month until the order is filled. The latter will supply two engines within nine months, four each succeeding month. The prices to be paid are about \$34,000 and \$27,500, respectively, for the Glasgow and Manchester engines.

RAILWAY CONSTRUCTION IN INDIA.—The Nizam's Guaranteed Railways Company have some extensions in contemplation. The idea is to get 3 ft. 3 in. gage communication with Gadag Junction on the Madras & Southern Maharatta system, whence there is a direct run to the port of Marmagoa. The lines to be built are one from Secunderabad southwards through Mahabubnagar to the Kistna, and then westwards to Raichore; and another from Raichore to Hutti; and a third from Hutti to Gadag. In this way a good deal of country will be opened up and traffic will be collected for Marmagoa. That port will be nearer than Bombay to many parts of the Hyderabad State, and the advantage thus gained should stimulate trade. Surveys are now being made, and when the estimates of cost have been framed capital will be raised to carry out the project. The company has now only 792 miles of open line, of which 441 are on the 3 ft. 3 in. gage, and there is ample scope for raising the mileage to over one thousand.

## Supply Trade News.

The Church-Davidson Company, Chicago, has been appointed general time inspector for the Chicago, Peoria & St. Louis.

The Maloney Oil & Manufacturing Company, Scranton, Pa., has opened an office in the Karpen building, Chicago. This company makes a specialty of high grade oil for signal lamps.

The Mid-Western Car Supply Company, Chicago, which was declared bankrupt on May 20, 1913, has filed an application for the discharge of its debts. A hearing will be held in Chicago on October 6.

A. L. Whipple has resigned his position as vice-president of the Standard Heat & Ventilation Company, New York, with office in Chicago, to enter the railway supply business on his own responsibility.

M. F. Ryan, who has been connected with the Pittsburgh Spring & Steel Company, Pittsburgh, Pa., for the past ten years, has been appointed general western sales agent of that company, with office in Chicago, in place of L. C. Noble, deceased.

W. H. Hooper, assistant to the president of the Chicago Car Heating Company, with office in Chicago, has resigned to become a vice-president of the Standard Heat & Ventilation Company, New York, with headquarters in the Peoples Gas building, Chicago.

C. H. Sanderson, engineer of switchboard and power station design for the Westinghouse Electric & Manufacturing Company, Pittsburgh, Pa., with office at East Pittsburgh, has resigned that position to become chief engineer of the Havana Electric Railway, Light & Power Company, with office at Havana, Cuba.

R. A. Paterson, formerly eastern manager of the C. F. Massey Co., Chicago, resigned from that concern on August 1, to become associated with Thomas A. Edison, as vice-president and manager of sales of the Edison Concrete Products Company, with sales offices in New York, Philadelphia and Boston. Mr. Paterson's headquarters will be in the St. James building, New York.

The American Locomotive Company, New York, has decided to discontinue the manufacture and sale of Alco automobiles and motor trucks. The automobile department, since its start in 1905, has been unprofitable to the company, and the prospects for the future of carrying on the business successfully are so uncertain as not to warrant, in the judgment of the directors, the continuance in this field of industry. The company will continue to make repair parts for its automobiles for a period of not less than five years.

### TRADE PUBLICATIONS.

**REINFORCING BARS.**—The Interstate Iron and Steel Company, Chicago, has issued an illustrated booklet on its rail carbon steel, plain and twisted reinforcing bars, including specifications and a number of illustrations of structures on which these bars have been used.

**GREAT NORTHERN.**—The passenger department has issued a folder describing short trips in Glacier National Park, and giving detailed directions and cost estimates for various kinds of tours within the park. The company has also issued a folder on vacation resorts in the northwest.

**RAIL ANTI-CREEPERS.**—The P. & M Company, Chicago, has issued a booklet entitled Interesting Installations of P & M Rail Anti-Creepers, which contains a large number of excellent half tone illustrations from photographs of tracks on which the Anti-Creeper has been installed since they were first put in service in 1907.

**ELECTRIC STEEL.**—The Illinois Steel Company, Chicago, has issued a small pamphlet describing the advantages of electric steel. This steel compares favorably in quality with crucible steel but can be made in larger quantities, therefore cheaper. This steel is especially adaptable for axles, side rods, piston rods, crank pins and tires.

## Railway Construction.

**ARIZONA ROADS.**—The Calumet & Arizona Mining Company is planning to build a railroad, it is said, from Tucson, Ariz., west to its mines in the Ajo district, about 85 miles. Surveys will soon be started under the direction of R. H. Jones.

**BRIDGEPORT & SOUTHERN.**—Incorporated in Illinois with \$25,000 capital and office at Bridgeport. The plans call for building from Bridgeport, in Lawrence County, Ill., south through Lawrence and Wabash counties to Mt. Carmel, 30 miles. The incorporators include John P. Klein and A. A. Pantelis, Chicago; T. S. Hogan and George B. Erb, Bridgeport.

**DENVER & SALT LAKE.**—An officer writes that track laying has just been started on the extension from Steamboat Springs, Colo., west via Hayden to Craig, 41 miles. M. A. Wogan was the general contractor for the grading work, and McCabe & Stein are doing the track laying. There will be two 70 ft. through girder bridges on the line. (August 8, p. 253.)

We are told that a contract will be entered into in about two weeks between the city officers of Denver, Colo., and the Denver & Salt Lake for the construction of the Moffatt tunnel under James Peak, which is to be about six miles long. It is expected that the work will be started within three or four months.

**HIWASSEE VALLEY.**—The contract has been let, it is said, to build from Andrews, N. C., on the Southern Railway southwest via Marble to Peach Tree, thence southeast via Hayesville to Hiwassee, Ga., 35 miles. J. Q. Barker, president, and W. C. Sanderlin, chief engineer, Andrews. (June 20, p. 1592.)

**HOUSTON & TEXAS CENTRAL.**—A franchise has been granted this company, it is said, to build from Eureka, Tex., to Pierce Junction. The work is to be started at once and pushed to completion. The new line is to be built to carry through freight around Houston, and will reduce the congested condition of the Houston freight yards.

**INTERCOLONIAL.**—Bids are wanted until September 8, it is said, for double-tracking work between St. Romuald, Que., and Chaudiere Curve. L. K. Jones is assistant deputy minister and secretary of the Department of Railways and Canals, at Ottawa, Ont.

See an item in General News regarding the construction of a new connecting line, also of terminal improvements at Halifax, N. S.

**NEW YORK SUBWAYS.**—The New York Public Service Commission, First district, on August 19, opened bids for the construction of Section No. 1 of Routes Nos. 36 and 37, known as the Woodside, Astoria & Corona Rapid Transit Railroad. The Snare & Triest Company, New York City, submitted the lowest of ten bids, their bid aggregating \$884,859. The Astoria, Woodside & Corona line, now partly under construction in Queens borough, begins at the Queens plaza of the Queensboro Bridge and runs respectively through Second avenue to Ditmars avenue, Astoria, and through Queens boulevard and Roosevelt avenue to Sycamore avenue, Corona. Both are to be elevated railroads, and are to be operated jointly by the Interborough Rapid Transit Company and the New York Municipal Railway Corporation. Section No. 1 covers the junction point of the two lines and the joint station near the Queensboro bridge. Contracts for the Astoria line, Section No. 2, and the Corona line, Section No. 3, were let several months ago, and construction work is now in progress. The contractors for the Astoria line are Cooper & Evans, and for the Corona line, the E. E. Smith Contracting Company, both of New York City. It is expected that a contract with the Snare & Triest Company for the construction of Section No. 1 will be executed within a short time, and the contractors will be required to begin work within 60 days after that date.

**NORTHPORT & SOUTHWESTERN.**—We are told that contracts will not be let until after January 1, 1914, to build from Northport, Neb., in a general southwest direction via Reddington, Harrisburg, Albin, Wyo., Pinebluff, Grover, Colo., and Greeley to Denver, about 200 miles. There will be five steel bridges, one 1,700 ft. bridge over Platte river, and four to have an average length of 30 ft. The company expects to develop a traffic in grain, sugar beets, livestock, creamery products, merchandise, etc.

C. F. Perry and B. W. Marshall, Pinebluff, Wyo., are promoters, and D. W. Trick is chief engineer.

**OKLAHOMA ROADS.**—Application has been made in Oklahoma for a charter to build from the northern boundary of the state in Nowata county southwest through the counties of Nowata, Rogers, Washington, Osage, Tulsa, Creek, Okmulgee, Okfuskee, Lincoln, Seminole, Pottawatomie, Cleveland, McClain, Garvin, Stephens, Carter, Jefferson and Love, about 300 miles. W. E. Hawley and C. L. Huonker, of Tulsa; W. J. Cornes and Edward S. Edge, of Cleveland, O., and J. H. Cleveland, of Skiatook, are interested.

**PENNSYLVANIA SOUTHERN.**—An officer writes that work is now under way, rebuilding the line from Sumerville, Pa., to Clarion, 16 miles. There will be a 120-ft. bridge on the line, and the company has given a contract to J. C. Trunk, Clarion, for rehabilitating the concrete engine house at Clarion, at a cost of \$6,000.

**ST. JOHN & QUEBEC.**—Construction work on the St. John valley line north of Centreville, N. B., and south of Gagetown is expected to be started during September. The company's plans call for building from St. John, N. B., northwest, following the St. John river to Grand Falls, 210 miles. It is understood that a tentative arrangement has been made with McFarlane & McDonald to build the section from Centreville to Andover, although no contract has been formally closed. The route north of Centreville has not yet been formally approved by the Minister of railways, but has been approved south of Gagetown to the King's county line. The construction work south of Gagetown will be carried out by J. H. Corbett & Sons Company, Inc., whose original contract was for building from Fredericton to Rothesay. The Corbett company has track laid on more than 25 miles south of Fredericton towards Gagetown. A. R. Gould, president, Presque Isle, Maine; R. Thompson, chief engineer, Fredericton, N. B. (June 7, 1912, p. 1263.)

**TEMPLE, NORTHWESTERN & GULF.**—The Railroad Commission of Texas has been advised that construction work on this line was recently resumed. The grade between Temple and Gatesville, with the exception of about one mile, was finished some time ago and four miles of track were laid. The plans call for building from Temple, northwest via Gatesville, Hamilton and Comanche. (February 28, p. 412.)

**TEXAS ROADS.**—Plans are being made, it is said, to build a line from Terrell, Tex., southeast via Willis Point, Myrtle Springs, Canton, and Ben Wheeler to Tyler, about 80 miles. W. M. Raley, M. C. Roberts and T. P. Davis, of Terrell; J. H. Vinson, Myrtle Springs; D. S. McPhail, Canton, and O. O. Morris, Ben Wheeler, are interested.

#### RAILWAY STRUCTURES.

**AUBURN, PA.**—An officer of the Philadelphia & Reading writes that a contract has been given to the James McGraw Co., Philadelphia, Pa., for the foundation work on two reinforced concrete slab bridges to be built over the Schuylkill river. Each bridge is to have 11 spans of 20 ft. each.

**CLARION, PA.**—See Pennsylvania Southern under railway construction.

**HALIFAX, N. S.**—See an item in General News regarding terminal improvements at Halifax.

**OGDEN, UTAH.**—The Denver & Rio Grande has received bids for a steel, brick and concrete freight house at this point.

**SCHUYLKILL HAVEN, PA.**—Bids have been received by the Philadelphia & Reading for a one-story freight house, 18 ft. x 264 ft. 5 in., to be of steel frame construction with brick end walls, and for a two-story brick office building, 18 ft. x 40 ft., to be built on Railroad avenue, Schuylkill Haven. The cost of the buildings will be about \$30,000.

**SILSBEE, TEX.**—The Gulf, Colorado & Santa Fe has let a contract to W. D. McCoy of Cleburne, Tex., for an 8-stall addition to its engine house at this point.

**SPARTANBURG, S. C.**—The South Carolina Power, Light & Railway Company, it is said, will build a machine shop, carpenter shop and a paint shop at Spartanburg. It is understood that the company will also enlarge its car barns.

## Railway Financial News.

**CHICAGO, MILWAUKEE & ST. PAUL.**—In listing on the New York Stock Exchange the \$30,000,000 general mortgage 4½ per cent. bonds sold a few months ago, the company stated that the proceeds of the sale were to be used as follows: \$10,648,000 to refund an equal amount of underlying bonds matured previously; \$13,358,371 for betterments and improvements, for Chicago terminals, new docks at Milwaukee and Racine, and other additional facilities; \$134,243 for real estate, and \$5,859,686 for new equipment.

**CLEVELAND, CINCINNATI, CHICAGO & ST. LOUIS.**—This company has asked the Ohio Public Service Commission for permission to issue \$758,000 general mortgage 4 per cent. bonds and sell them at 78.

At the directors' meeting on August 26 the regular quarterly dividend of 1¼ per cent. on the preferred stock was passed. Dividends at the rate of 5 per cent. yearly have been paid on the preferred stock since 1899. The last dividend on the common stock was 2 per cent., paid in 1910.

**COLORADO, KANSAS & OKLAHOMA.**—*The Commercial & Financial Chronicle* quotes an officer as saying that this company bought at foreclosure sale on August 6 the property of the Scott City Northern, which road ran from Scott City, Kan., to Winona, about 52 miles.

**DENVER & SALT LAKE.**—This company, which is the successor of the Denver, Northwestern & Pacific, has terminated its lease of the Northwestern Terminal in Denver and withdrawn its guarantee from the \$2,025,000 Northwestern Terminal 5 per cent. bonds. The Denver, Laramie & Northwestern also uses the Northwestern Terminal property.

**LOUISIANA & NORTH WEST.**—On application of the Baldwin Locomotive Works, Judge Foster, of the United States district court at New Orleans, has appointed George W. Hunter receiver. The Louisiana & North West runs from McNeil, Ark., to Natchitoches, La., 121 miles.

**NEW ORLEANS, MOBILE & CHICAGO.**—A suit has been filed in the New York supreme court by Stanley Hess, as assignee of Kuhn, Loeb & Co., for \$219,583, balance with interest due on two loans aggregating \$633,000.

**NEW YORK, NEW HAVEN & HARTFORD.**—Stockholders, at a special meeting on August 22, voted to issue \$67,552,400 convertible debenture 6 per cent. bonds, and voted to approve the net increase in the authorized capital stock to provide for the conversion of these bonds at par. The bonds are to be convertible at par from 1918 to 1928. They are dated October 1, 1913-1933. The debentures are to be offered to stockholders at par, and the company is to receive 97½, the underwriting syndicate, headed by J. P. Morgan & Co., to receive 2½ per cent. The proceeds from the sale of these debentures will provide for indebtedness amounting to \$40,000,000, maturing December 1, 1913, and \$5,000,000 maturing February 1, 1914, and will provide for the additional capital required to complete the electrification between Stamford and New York, buy new steel equipment, etc.

The directors, at a meeting subsequent to the stockholder meeting, elected W. Murray Crane, of Dalton, Mass., a director, succeeding D. H. Warner, of Bridgeport, Conn., signed, and elected Theodore N. Vail a member of the executive committee.

**NORTHWESTERN TERMINAL.**—See Denver & Salt Lake.

**PITTSBURGH, CINCINNATI, CHICAGO & ST. LOUIS.**—This company has sold to Kuhn, Loeb & Company and Speyer & Company both of New York, \$7,000,000 consolidated mortgage 4½ per cent. series I bonds. The total authorized issue of consolidated mortgage bonds is \$75,000,000, of which, including present bonds, there are outstanding \$67,078,000 issued at various rates of interest, the last previous issue being made in 1910 at 4 per cent. Each series runs for 50 years. The proceeds from the sale will be used to retire \$3,000,000 of bonds raised by the company and Indiana 5 per cent. bonds, due January 1, 1914, and \$2,130,000 of bonds due there is and there is

# Railway Age Gazette

PUBLISHED EVERY FRIDAY AND DAILY EIGHT TIMES IN JUNE, BY THE  
SIMMONS-BOARDMAN PUBLISHING COMPANY,  
WOOLWORTH BUILDING, NEW YORK.

CHICAGO: Transportation Bldg. CLEVELAND: Citizens' Bldg.  
LONDON: Queen Anne's Chambers, Westminster.

E. A. SIMMONS, *President.*

L. B. SHERMAN, *Vice-President.* HENRY LEE, *Sec'y & Treas.*  
The address of the company is the address of the officers.

EDITORS.

SAMUEL O. DUNN, *Editor.*

ROY V. WRIGHT, <i>Managing Editor.</i>	H. H. SIMMONS	E. S. FAUST
W. E. HOOPER	H. F. LANE	F. W. KRAEGER
B. B. ADAMS	E. A. AVERILL	A. D. CLOUD
E. T. HOWSON	R. E. THAYER	GEORGE L. FOWLER
	A. C. LOUDON	

Subscriptions, including 52 regular weekly issues and special daily editions published from time to time in New York, or in places other than New York, payable in advance and postage free:

United States and Mexico.....	\$5.00
Canada.....	6.00
Foreign Countries (excepting daily editions).....	8.00
Single Copies.....	15 cents each

Engineering and Maintenance of Way Edition and four Maintenance of Way Convention Daily issues, North America, \$1.00; foreign, \$2.00.

Entered at the Post Office at New York, N. Y., as mail matter of the second class.

WE GUARANTEE, that of this issue 8,150 copies were printed; that of those 8,150 copies, 6,696 were mailed to regular paid subscribers and 850 were provided for counter and news companies' sales; that the total copies printed this year to date were 310,409—an average of 8,623 copies a week.

VOLUME 55. SEPTEMBER 5, 1913. NUMBER 10.

## CONTENTS

<b>EDITORIAL:</b>	
Editorial Notes.....	397
Car Pooling Under Government Ownership.....	398
Increasing the Efficiency of Equipment.....	399
Bridge Erection Under Traffic.....	400
Canadian Pacific.....	400, 438
New Books.....	402
<b>LETTERS TO THE EDITOR:</b>	
Fuel Economy.....	402
<b>MISCELLANEOUS:</b>	
"Getting More Movement for Freight Cars".....	403
*Atlantic Type Inspection Locomotive.....	404
E. P. Ripley on Car Shortages.....	406
*New Ohio River Bridge at Kenova, W. Va.....	407
A Correction.....	413
Uncle Sam's Freight Cars; by J. Garrett Hill.....	414
Air Brakes and Modern Conditions; by W. V. Turner and P. H. Donovan.....	415
Principles of Electric Railroad; by C. L. de Muralt.....	418
A Record Shipment by Parcel Post.....	420
*Alaska's Need of Railway Development; by E. E. Swergal.....	421
Valuation of Kansas Railways.....	424
Foreign Railway Notes.....	402, 406, 413, 418, 420, 423
<b>GENERAL NEWS SECTION.....</b>	<b>425</b>

\*Illustrated.

in substituting steel for wooden passenger cars. This has been done at great expense and in spite of the fact that the steel car is not ideal. In a violent collision an immense momentum has got to be destroyed in some way. A collision between two all-steel trains, one or both moving rapidly, is bound to wreck something. This test has never yet been made. The Pullman Company has built steel cars rapidly. Could it serve the public better and with reasonable economy by at once destroying hundreds of sound wooden cars? Such destruction, by Pullman and all the roads, seems to be what the clamorous editors and congressmen demand, ignoring the question of cost, which involves hundreds of millions of dollars. And if wooden cars are to be tolerated at all, at any time, they must be used in the rush of travel following Labor Day, when every available car must be put in service. These difficulties of the car problem serve once more as a reminder that the vital issue is the prevention, not the mitigation of collisions.

THE enclosed disk signal also furnishes food for columns of criticism by the newspapers, and the fact that the railroad had decided to put in semaphores in place of the disks on the New Haven-Springfield line is taken as conclusive condemnatory evidence. In justice to the first class roads which have used disks extensively for 20 years, and with a high degree of safety, it should be said that these signals have been and are used on lines traversed by the fastest trains in the world, where trains are not only fast but frequent. The last government report showed 3,615 miles of track thus signaled. At night the question of disk versus semaphore has no weight, as the light constitutes the signal. The North Haven collision occurred at 7 a. m. in a dense fog, and quite likely the engineman saw the light before he saw the daylight signal. Railroads instal semaphores so as to make the automatic signals uniform in aspect with the signals at junctions, and so as to have a three-position signal, which also is desirable on account of uniformity and economy; but the denunciation of the disk, because it is a disk, is based largely on tradition and sentiment. The argument that a semaphore is distinguishable at a greater distance may be admitted; but that is not a vital issue. In the North Haven case the question of visibility at a distance is likely to prove wholly immaterial, for nothing could be seen more than about 300 ft. away, on account of the fog. We pointed out last March (page 657) the illogical character of the Connecticut Commission's recommendation to abandon disks.

WILLIAM W. WHEATLY, in reading a paper on Railroad Economics, before the American Association of Railroad Superintendents (the meeting of which was commented on at some length last week), reiterating an old fallacy, rather ludicrously emphasized the author's unfitness for discussing "railroad economics." Mr. Wheatly says, in speaking of the increase in the funded debt of railroads:

The rapid progress of invention and discovery and the natural waste of wear and tear have made it necessary about every 20 years to rebuild and reequip the entire system. Almost the entire cost of each one of these cycles of improvement has been paid for with money freshly borrowed from the public. The total indebtedness of the railroad system [Baltimore & Ohio] today includes practically all of the plant and equipment that have been consumed since the beginning in 1827. As the old mortgage debts fell due, they were refunded by creating new and larger mortgages.

Apparently Mr. Wheatly has no conception of the meaning of *fixed capital*. He goes on to enlarge on the idea that these new mortgages refunding former mortgages are drawn up on property which no longer exists. The absurdity of this is apparent if we translate the Wheatly argument into a concrete example. A mortgage is made covering 100 miles of line. This line is repaired currently from earnings. As ties wear out, new ties are placed in track, and their cost is charged to the operating expenses of the current year. The same is true with rails and every other part of the line. Fifty years from the date of the first mortgage a new mortgage is drawn up secured on the property as it then is, and the proceeds from the sale of the bonds under this new mortgage are used to pay off the matured bonds

ANOTHER rear collision, killing twenty-three passengers, once more brings down on the New Haven road showers of angry denunciation, not only from yellow journals, but from others, more conservative, as well. The main question, that of the observance of signals by the engineman, cannot be considered at this time, as not enough evidence has been gathered. Neither can the flagman's conduct be criticized, for the question whether he could or should have gone back farther can be answered only after a careful investigation, which at this writing has not been made. But the reiterated denunciation of the "old wooden cars" calls for a word in defense of the road and of the Pullman company, owner of the cars. In no line of improvement has there been more rapid progress during the past five years than



issued under the old mortgage. Not even the most ardent of railroad sympathizers would dare claim that during the 50 years the road should have earned enough not only to pay for the upkeep and replacement in kind of its property, but to pay off to its security holders interest and principal as well. The amortization of a debt is proper where the security for the debt is to be allowed to run down and eventually become worthless; but in the case of a railroad, maintenance charges paid from current earnings are themselves an amortization, and the only reason that railroad mortgages are drawn for larger and larger sums is that the railroad properties are not only being maintained and replaced in kind, but are being added to by new improvements as well. In picking out the Baltimore & Ohio Mr. Wheatly chose an example that in recent years has been particularly unsuited for his purpose. One of Mr. Willard's first acts on the Baltimore & Ohio was to write off—subtract from the profits—over \$8,000,000 for equipment which had become, in his opinion, obsolete without having been replaced.

ONE of the best examples of the continual change in railway conditions is afforded by the remarkable development in railway facilities that is taking place in the Northwest and the vigorous contest that is being waged there between the big systems. Until about seven or eight years ago the Hill lines, the Great Northern and the Northern Pacific, were almost alone in the vast territory from the Missouri river to the Pacific coast north of the southern boundaries of Washington and Montana. The first serious invasion was that of the Chicago, Milwaukee & St. Paul, whose coast extension traverses territory formerly served exclusively by the Northern Pacific and parallels the older road for many miles. Shortly after the construction of the St. Paul's coast extension the Harriman lines forced an entrance from Portland north into Tacoma and Seattle over the tracks of the Northern Pacific, and followed this with the construction of the North coast line into the Yakima Valley and a new line south from Spokane towards Portland. The Hill lines have also been on the offensive, having built the Deschutes line into central Oregon, a territory previously served only by the Harriman lines, and followed this by the construction of the Oregon Electric down the rich Willamette Valley, which always has been a Southern Pacific stronghold. In eastern Washington and Montana the contest has been waged principally between the Hill system and the St. Paul, although there have been rumors of an invasion of eastern Montana by the Soo line. One of the most important developments in this vicinity is the new terminal of the St. Paul at Spokane, which is now nearing completion. When this is in operation the St. Paul will be a very active competitor for traffic both east and west, as it will be the short line between important points. The advantage the road derives from this circumstance has been increased by the location of its freight and passenger facilities closer to the business section of Spokane than the previously existing facilities. In Montana the St. Paul is building a line from Lewistown northwest to Great Falls, a distance of 137 miles, and an additional distance in the same direction of 68 miles parallel to the Billings—Great Falls line of the Great Northern. The Great Northern, on the other hand, is building a long line from Lewistown east into North Dakota north of the St. Paul's main line, which is obviously intended to keep the latter road out of this country. While the rivalry is most pronounced in the west, the Hill lines have also been forced to meet new competitors in Minnesota. Only a few years ago the Soo built a line from Thief River Falls, Minn., west into North Dakota, cutting across a territory already served by the Great Northern, while last year the same road completed a short line from St. Paul to Duluth, making it an active competitor for this business. In its turn, the Great Northern built a line from Fargo, N. D., northwest to Surrey last year, which closely parallels the main line of the Soo. All of these projects indicate the intense rivalry between the large railway systems

in the Northwest, and the effect of competition is stimulating railway construction in undeveloped territory—perhaps in many cases well in advance of the actual requirements.

#### CAR POOLING UNDER GOVERNMENT OWNERSHIP.

EVERYBODY'S MAGAZINE for September publishes an article in favor of pooling of freight cars. The method proposed is that the government shall purchase all the freight cars and rent them out to the railways. The article is entitled "Uncle Sam's Freight Cars," and is written by J. Garrett Hill, who is introduced by the editors as "an expert," and "Commercial Agent of the Queen & Crescent Route."

There is a great deal to be said in favor of the pooling of freight cars, and there is also a great deal to be said against it, but the subject is one which should be handled with a great deal of care. Arguments on both sides should be carefully weighed and should be based upon facts.

The article in question is unfortunately based upon a series of misconceptions. The author proposes that the government, in buying the freight cars, shall pay for them \$800 each. Its rate of rental to the railways is to be on the basis of 50 cents per car per day, plus one cent a mile run. This is an advance of over 50 cents above the present per diem rate. At these high rates the author correctly states that the government could keep the cars in repair and make quite a good deal of money, but unfortunately he understates the cost of upkeep and operation, and as a result he shows profits for the government which are extraordinarily large. For instance, he estimates the cost of upkeep and operation of all the freight cars in the country as \$80,000,000 per year. Now, the mere repairs to freight cars, as reported to the Interstate Commerce Commission for the year 1910, amounted to over \$137,000,000; and this does not cover renewals or depreciation.

Suppose that the government did purchase all the freight cars in the country; how would it get a right to hire them out to the railways at such an extortionate rate as to insure it a large profit on the transaction? Would not this be confiscation of the worst kind?

Mr. Hill states that railway earnings would be increased, for "sufficient equipment could be had at all times by the railways, while under the present system the loss to the railways through lack of equipment is enormous." How would this result be accomplished? It might be accomplished if the government's method of distributing cars was vastly better than the present method of the railways, but Mr. Hill is absolutely silent as to the methods which the government should pursue.

The author arranges that the government shall spend \$1,000,000,000 for storage yards for its cars. Just why this enormous expenditure is necessary he does not say, nor whether the storage yards are to be built new, or are to be bought from the railways. Apparently, they are to be built new, as the author does not speak of the advantage which the railways would secure in receiving this \$1,000,000,000 from the government. He does suggest that the \$2,000,000,000 which the railways would receive for the cars would be useful to increase their terminals, and would meet all demands for improvements for years to come. In view of the recent increases in the capital of the railways, and others that are needed, it is to be feared that the \$2,000,000,000 would not last many years.

The author points out that if the Pennsylvania System were to sell its cars to the government it would receive over \$197,000,000, which is a large amount of money; but he does not say why the Pennsylvania should be willing to part with its equipment, even at a liberal valuation, if it were to be obliged to hire equipment at a rate more than 50 per cent. in excess of what it is now paying.

It is true that the use of freight cars indiscriminately, without regard to their ownership, would be an economical arrangement for the railways taken as a whole, but unless such a plan is surrounded by safeguards, which have not as yet been devised, and which certainly are not suggested by Mr. Hill, such

a plan would work an injustice on the originating roads in times of car shortage, and would work further injustice on the distributing roads in times of car surplus.

So far all efforts toward progress in the direction of pooling have been blocked, on the one hand by the railways owning a large number of cars which insist on controlling their own equipment, and on the other hand, by roads which are profiting by the present arrangement. The combination of these two classes of roads has been strong enough to hold matters very much as they are, and articles like Mr. Hill's, which give bad reasons for good results, are likely to retard the achievement of these results.

#### INCREASING THE EFFICIENCY OF EQUIPMENT.

FROM a purely economic standpoint the most important problem confronting the railway officers of America is that of securing a more satisfactory ton mileage per day and per year from each freight car and locomotive. The power of locomotives and the capacity of cars have been increased greatly within the last decade. The ton mileage moved per locomotive and per car has not been increased in proportion. The *Railway Age Gazette* is publishing a series of discussions on the subject, "Getting More Movement for Freight Cars." The first article, which was by Arthur Hale, general agent of the American Railway Association, appeared in the issue of August 1, page 175. In the issue of August 29 we published an article on the same general subject by B. A. Worthington, president of the Chicago & Alton, also a letter from Mr. Hale on "Car Movement and Interchange." This week we publish articles on car movement by F. M. Lucore, assistant general manager of the Sunset Central Lines, and E. H. DeGroot, Jr., superintendent of transportation of the Chicago & Eastern Illinois.

The subject is really a broader one than merely that of getting more movement from cars. As already indicated, the real problem is that of getting more ton mileage from each engine and car. There are numerous things which must be done if equipment is to be worked with the maximum practicable efficiency. In the first place, as is generally recognized by those acquainted with the situation, the co-operation of the shipping public must be secured. The most economical way to increase the efficiency of equipment is to increase the size of the average load hauled per car. In this way the total amount of traffic handled may be augmented with no corresponding addition to investment in equipment, main tracks and yardage, or to operating expenses. It is well known that the average tons hauled per car have not increased anywhere near as much in proportion as has the average capacity per car, and it is very doubtful if substantial increases can be made in future in the average car load without increases being made in minimum carload weights. It ought to be possible, by co-operation between the railways and the shippers, to bring about increases in minimum weights which would not be unduly burdensome to commercial interests.

The movement per car per day can be increased by reducing the time that cars are held for loading and unloading. The maximum free time ordinarily allowed for these purposes is 48 hours. The demurrage assessed thereafter is regarded by some as a charge for the rendering of a service; by others, as a penalty for keeping cars out of service. If it is a charge for the rendering of a service it ought to be large enough to cover the cost of the service and a reasonable profit. On this theory, the prevalent demurrage rate of \$1 per car per day is inadequate. The average earnings per freight car per day are about \$2.50—in 1912 they were \$2.57. Therefore, while a car is kept out of service accumulating demurrage the railway is receiving a smaller return from it than when it is being used to move freight. The prevalent demurrage charge is also too small if considered as a penalty. The purpose of a penalty is to prevent people from doing the thing for the doing of which the penalty is imposed; and the reports of the demurrage bureaus show that shippers and consignees hold many cars in excess of the period of free

time, and that this is one of the main causes of the small average movement per car per day. The obvious remedy, whether demurrage be a charge or a penalty, is to increase the demurrage rate. Probably in no other country is the demurrage rate so low as in the United States in proportion to the capacity of cars. In the long run the public as well as the railways would benefit by the increase in car efficiency that would result from putting the demurrage rate on a more reasonable basis.

In recent years, when shippers have complained about car shortages, the spokesmen of the railways have very frequently reminded them that the delays to cars caused by shippers themselves are among the main causes of such conditions. But railway officers have not blinded themselves to the fact that there are many preventable delays to cars while they are in the hands of the railways, and they have been devoting much study to the causes of these and much thought and energy to devising and applying methods for reducing them. The articles on the subject which have been appearing in the *Railway Age Gazette* have pointed out many of these causes and told of some of the remedies that are being applied. The fact that stands out very prominently, however, that in spite of all the investigating that has been done and the efficiency methods that have been tried, the average mileage per car per day and the average ton mileage per car per day in the entire country have not been materially increased.

The discussions of the subject and the statistics relating to it show that while we know a good deal about where the delays to cars occur and the causes of them, we still know far too little about these things. We know that most of the delays occur at stations and in yards; but why, when we know this, do so many preventable delays continue to occur there? There are many answers to this question, but before it shall be satisfactorily and fully answered it will be necessary to have far more thorough investigations made than as yet have been undertaken. One of the most important prerequisites to the solution of the problem of car efficiency is to have the causes of delays on every railroad, and at every station and yard on every railroad, investigated and reported in minute detail.

This searching investigation must be followed by an equally thorough and detailed application of the remedies that it suggests. We already know that one of the pressing needs on most roads is the enlargement and improvement of station and terminal tracks. The delays to cars on many roads are chiefly due to the fact that they are being maneuvered on too restricted a trackage. The needed expansion of station and terminal facilities can be secured only by the investment of large amounts of capital, and the difficulties in the way of raising this new capital are familiar. But while an enlargement of station and terminal trackage would afford opportunity for increasing car efficiency, it would not of itself increase it. In order to get the maximum practicable ton mileage per car per day it will be necessary, no matter what physical facilities are provided, to devise better means for following and stimulating the movement of cars from the moment that they are put under load until the moment they are delivered to the railway unloaded; and in any state of the physical facilities the use of such means will increase car efficiency.

Aside from the development of terminal facilities, the means requisite to increasing the efficiency of the use of equipment may be summed up in two words. These words are "increased supervision." Increased supervision is needed in the operating departments of most railways, from the office of the president down to the offices of the trainmaster, the yardmaster and the train dispatcher. Most railways are under-officered, especially in the lower ranks, and a few of them are so organized and officered as to enable the officers on the firing line—the superintendent, the trainmaster, the traveling engineer, the yardmaster, the dispatcher—to get the maximum efficiency from train employees and equipment. It is probable that there are few railroads that could not increase the efficiency of train employees, of locomotives and of cars, and thereby reduce their operating expenses, by in-

creasing the number of officers employed to exercise direct and detailed supervision over the movement of equipment and the work of all employees concerned with train operation.

**BRIDGE ERECTION UNDER TRAFFIC.**

**A**LTHOUGH difficult problems are frequently presented by the necessity for renewing bridges under traffic, and unusual methods are sometimes adopted for handling such work, most of these methods would seem very simple in comparison with the elaborate system which was worked out and successfully used for building the new Ohio river bridge of the Norfolk & Western. For reasons stated in the description of this work elsewhere in this issue, it was essential that the new bridge occupy the same location and have the same span lengths as the old structure, and as 60 to 70 train movements a day were being made over the gauntleted track on the bridge it was impossible to use any method of erection which would require holding this track even for short periods. By delivering all material used in the alterations to the piers on barges on the river, and by handling the steel for the new superstructure on temporary tracks supported on cantilevered brackets outside the new trusses, the use of the main track on the bridge for construction purposes was limited to an occasional movement of the work engine with cars of steel or equipment for use on the other end before the material tracks were completed for the full length.

In working out the details of this plan many difficulties had to be anticipated and provided for to keep the cost of the work within reasonable bounds, and to prevent accident. The problem of designing the new trusses so as to carry the temporary material tracks without too greatly increasing the cost was solved by using the stringers intended for the new bridge on temporary brackets cantilevered out from the end of the new floor beams. By allowing the traffic to use the old track structure until all the steel in the new bridges had been erected these stringers could be taken from the temporary track and placed in the permanent deck so that the only loss was in the temporary brackets. Although it might be expected that the cost of the work handled under such conditions would be unusually high, this was not the case. The thoroughness with which the details of the plan were worked out made it possible to prosecute the work with very little interruption, to the construction forces and no delays to traffic, and the saving effected by using the old substructure and alinement much more than offset the additional cost of handling the erection in this manner.

The adoption of a 43 ft. truss spacing to place the new trusses outside the old made necessary the use of deep pier girders to carry these trusses on piers only 45 ft. long. To erect the new double track steel viaduct on the old alinement without interrupting traffic a special traveler was used which would allow a train to pass under it on one track. In closing the middle span, which was erected cantilever from both ends, the outer ends of the adjacent spans which were used as anchors during erection were jacked up enough to bring the top chord members together, a method which was first used on the Ohio river bridge at Louisville for a much longer span, and which proved simple and convenient both at Louisville and Kenova. These instances are typical of the advanced practice followed in the erection of this structure.

**CANADIAN PACIFIC.**

**E**ACH succeeding balance sheet of the Canadian Pacific is a fascinating study. Possibly if we could have seen a balance sheet of the Standard Oil before the decree of dissolution it might have been comparable to this balance sheet of what is in many ways the greatest railroad corporation in the world. At the end of the fiscal year 1913 (June 30) the Canadian Pacific was operating 11,602 miles and earned from operation during that year a total of \$139,396,000 and had outstanding but \$13,158,000 mortgage bonds. In other words, here is a railroad com-

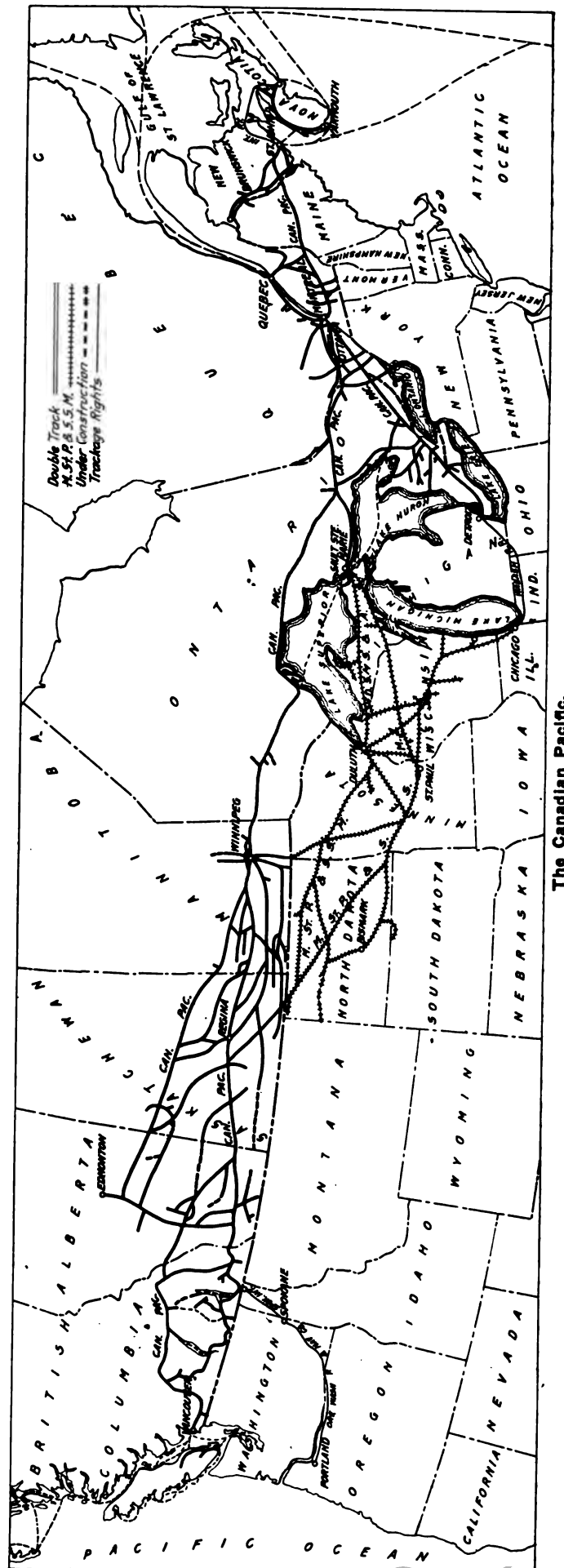

The Canadian Pacific.

pany with a bonded indebtedness of but a little over \$1,000 a mile that earns over \$11,000 a mile. The amounts due from agents and conductors and miscellaneous accounts receivable—\$11,253,000—and the amount temporarily invested in government securities—\$10,089,000—would have been more than sufficient to have paid the entire mortgage debt of the company, leaving \$30,275,000 cash on hand, \$12,073,000 advances and investments, exclusive of advances to lines under construction, and \$44,499,000 deferred payments on land and town sites sales to meet current liabilities totaling \$30,511,000. This information is given in the body of the balance sheet. The three-line note attached to the balance sheet, which is of itself rather fascinating, mentions that in addition to the assets shown the company owns 7,985,244 acres of land.

In 1912 the Canadian Pacific was unique among all the large railroad systems on this continent in being able to show as low an operating ratio as in the year before. In 1913 the operating ratio was 66.82 per cent., as compared with 64.89 per cent. in 1912; but during the past year the company has put in operation over 600 miles of new line. On a very considerable part of this new mileage revenues are not probably even paying operating expenses, while the inclusion of the figures for this new mileage tends to materially increase the ratio for total expenses to total revenues. President Shaughnessy mentions the cost of both maintenance and operation of this new mileage, but it is probable that it is chiefly in transportation expenses that the new mileage has disproportionately burdened the total. Total operating revenues in 1913 were \$139,396,000 as against \$123,320,000, while operating expenses were \$93,150,000 in 1913, as against \$80,021,000 in 1912. The transportation expenses were \$46,074,000 in 1913 and \$38,923,000 in 1912.

The Canadian Pacific has had some labor troubles during the year and the president's report mentions increases in certain rates of pay; but there are many indications in the annual report for 1913 that the materially larger transportation expenses are due in great part to the operation of the new and as yet unprofitable mileage. With an increase in ton miles carried of 10.43 per cent., there was an increase of but 7.36 per cent. in total freight car miles and an increase of 18.13 per cent. in empty car mileage. Despite the increase in empty car mileage, there was an increase of 2.45 per cent. in the average train load, the train load in 1913 being 381 tons.

An increase or decrease in empty car mileage is presumably due to changes in the character or direction of traffic. A quite notable increase in train load may be shown simply through a reduction of empty car mileage, the result of some new traffic without any more effective work on the part of the operating department. An increase, however, in revenue train load coincident with an increase in empty car mileage means either a reduction of grade, heavier power or a more effective use of the power in service.

The C. P. R. spent \$30,818,000 for additional rolling stock, shops and machinery in 1913, and there were in operation 2,052 locomotives at the end of the year, as compared with 1,820 in operation at the beginning of the year. The company spent a total of \$6,108,000 for double tracking, in the process of which undoubtedly there was some grade revision work. This addition of modern power, the grade revision work and an increase of 5.68 per cent. in the loading per loaded car, in part explains the increase from 372 tons to 381 tons in the revenue train load.

Besides the increases in transportation and maintenance expenses there was quite a marked increase in traffic expenses, these expenses amounting to \$3,377,000 last year as against \$2,881,000 the year before. The Canadian Pacific's traffic expenses are not high relative to its gross earnings, but are quite remarkably effective. It is the old story that advertising when backed up by real merit shows a high return on the investment. The principal efforts of the Canadian Pacific toward getting business are directed to the creation of new business. The

C. P. R. owes a large part of its financial success to the substantial loyalty of the Canadian people to their greatest institution; but, on the other hand, mere figures cannot measure Canada's debt to the railroad.

There have been described in detail at various times in the *Railway Age Gazette* some of the methods by which the Canadian Pacific is developing the territory which it serves and inducing the immigration into its territory of settlers from Europe and England. The construction of 600 miles of road in a single year speaks eloquently of the fact that railroad building in Canada by the C. P. R. is still keeping ahead of the requirements of population. A glance at the accompanying map will show what an extensive program of new construction the Canadian Pacific now has under way. In 1913 the total amount spent for new construction and for additions and improvements, exclusive of expenditures for new shops and new equipment, amounted to \$45,922,726.

The character of freight traffic carried is a striking justification, if any justification is necessary, of the expenditures that are being made by the Canadian Pacific to develop the Canadian agricultural and lumber industries, and to induce settlers to immigrate into Canada. The total number of tons carried in 1913 amounted to 29,472,000 tons. This presumably is long tons, and the Canadian Pacific classifies its traffic according to the English system showing barrels of flour, bushels of grain, etc., so that only an approximately correct division can be made on a tonnage basis. Approximately the grain furnished 16 per cent. of the total tonnage, flour about 2 per cent., livestock about 3 per cent., lumber about 16 per cent., and manufactured articles about 32 per cent. All other articles only furnish about 32 per cent. Coal, therefore, must make up only a small portion of the Canadian Pacific's total tonnage; and it is interesting to note how important is the tonnage of manufactured articles. Of course, the Canadian Pacific competes on manufactured articles westbound with American transcontinental roads, and not all of the 9,519,000 tons of these articles carried in 1913 went to Canadian settlers.

The following table shows the ratio of maintenance and transportation expenses to total operating revenues:

Maintenance of way .....	13 per cent.
Maintenance of equipment .....	12 per cent.
Transportation expenses .....	33 per cent.
Traffic expenses .....	2 per cent.

The following table shows the principal figures for operation in the fiscal year ended June 30, 1913, compared with that in the previous fiscal year:

	1913.	1912.
Mileage operated .....	11,602	10,983
Freight revenue .....	\$89,637,227	\$79,833,224
Passenger revenue .....	35,545,062	31,812,208
Mail .....	921,683	859,558
Sleeping car, express, telegraph and miscellaneous .....	13,273,732	10,814,042
Total operating revenues .....	139,395,700	123,319,541
Maintenance of way and structures .....	18,498,741	17,719,795
Maintenance of equipment .....	17,198,573	13,608,708
Traffic .....	3,376,981	2,880,800
Transportation expenses .....	46,074,299	38,923,050
Parlor and sleeping car expenses .....	1,241,700	944,594
Expenses of lake and river steamers .....	1,113,808	1,064,011
Commercial telegraph .....	1,691,953	1,435,944
General expenses .....	3,953,770	3,444,395
Total operating expenses .....	93,149,826	80,021,298
*Operating income .....	46,245,874	43,298,242
Net earnings of steamships in excess of amount included in operating revenues .....	1,245,563	1,104,449
Net corporate income .....	36,615,085	33,877,754
Replacement fund and pension fund .....	1,125,000	1,125,000
Dividends .....	17,189,827	15,192,235
†Surplus .....	18,310,258	17,560,519

\*Taxes are included in operating expenses.

†No account is taken of the profits from land sales, from which profits 3 per cent. additional dividends are paid on the ordinary stock, making 10 per cent. paid in all.

‡These ratios are not accurately comparable with roads reporting to the Interstate Commerce Commission, since operating revenues includes revenue from sleeping cars, restaurants, some steamship revenues, etc.

## NEW BOOKS.

*The Lure of the Iron Trail.* By Ward W. Adair. New York: Association Press, 124 East 28th street. Cloth, 201 pages, 5 in. x 7 $\frac{3}{4}$  in. Price \$1.

This book is wholly religious, yet filled with everyday life, and true to nature. It consists of thirteen stories of railroad men who had wasted their substance in riotous living, but who turned to God and reformed, thereafter living lives of usefulness and honor. Mr. Adair is a skilful and entertaining writer. He is the secretary of the Young Men's Christian Association at the Grand Central Terminal, New York City and a popular friend of the men who use the rooms of that association. Some of his stories are a trifle strong in color for the conservative reader, and now and then his knowledge of railroad practice is slightly awry; but as a whole the book is exceedingly well written, and the imaginary conversations of trainmen, shopmen, clerks and all classes have the marks of reality. Indeed, for the general reader, Mr. Adair's work gives pictures of railroad life of a quality rarely found; true in detail, sane in spirit and always of high moral and ethical tone. The subjects of the sketches are real men and some of the narratives give real names—Tom Keenan, for example, the Lackawanna engineman who has preached all over the country; also Charlie Haight, who received the Congressional medal for saving the life of a little child. The book contains some good illustrations, including a facsimile of President Roosevelt's letter to Haight.

*Electric Interlocking Handbook.* Henry M. Sperry, Editor, Rochester, N. Y.: General Railway Signal Company. Leather, 435 pages, 4 $\frac{1}{4}$  in. x 7 in. Price \$3.

This book is an advertisement of the machines and apparatus made by the publishers; but it contains such a large amount of what may be called staple information, such as one finds in standard engineering pocket books, that it deserves to be included in that class. The engineers of this company, who have prepared the work, not only have high reputations in their profession, but are known also as hard workers, and this book gives new evidence of that fact.

The scope of the work may be gathered from the chapter headings: G. R. S. Electric Interlocking System; G. R. S. Interlocking Appliances; G. R. S. Alternating Current Appliances; Signal Lighting and Interlocking Plants; Electric Locking and Check Locking; Installation and Operating Data (seven chapters devoted successively to power plants and switch boards, electric interlocking machines, switch mechanisms, signal mechanisms, relays and indicators, transformers and primary batteries); Wire Trunking and Conduit; Concrete; Written Circuits; Aspects and Symbols; Data.

Each chapter may be termed a condensed treatise. Standards of the Railway Signal Association innumerable are quoted, amplified and explained. Circuit diagrams are made plain, where necessary or desirable, by the use of two colors, red and black. The foreman of construction or the maintainer finds at every step not only concise instruction what to do, but lucid explanations of reasons, which aid him to master the subject. There is a good variety of data in tables, such as is found in mechanical engineers' handbooks. The instructions for oiling an automatic signal mechanism are given in the shape of a skeleton drawing, with red lines leading to every oil cup and every surface needing lubrication. The chapter on "written circuits" consists of a concise code of instructions, with suitable symbols, for use on the ground in installing extensive interlocking plants.

The introduction to the book is a brief historical sketch by W. W. Salmon, president of the company. He predicts that within the next ten years many important railways will have all or nearly all of their block signals and their interlocking machines on their main lines operated by electricity. Multiplying the number of levers of this company's interlocking machines now in service by the number of years that they have been in service, the product is 110,000, a number which is termed "110,000 lever years."

## Letters to the Editor.

### FUEL ECONOMY.

BALTIMORE, Md., August 13, 1913.

TO THE EDITOR OF THE RAILWAY AGE GAZETTE:

I have read with a great deal of interest and appreciation D. C. Buell's article on this subject in the *Railway Age Gazette* of August 8, and I believe that if his suggestions were put into practice they would be the means of saving a great deal of coal for the railroads.

However, I have a few suggestions to offer. First, enginemen and firemen, who are the ones who handle the bulk of the coal and consequently can save or waste more than any other employees, must be interested in their work and give at all times their hearty co-operation. To obtain this may prove very difficult to some railroad men, but in reality it is not. There is only one requisite, that harmony and good feeling exist between the officers and employees. This spirit can be created in various ways, but to my mind the most practicable method is for the officers to show their appreciation of good work. Any man in the rank and file realizes that he must work for a living, but when he sees that his work is fully appreciated he will always strive to do his best. I also think we should have more frequent talks on fuel economy and other important subjects from the higher officers; lectures three or four times a year would be advisable. Second, the enginemen and firemen should be properly instructed at every opportunity so that they may become as efficient in their work as possible. The firemen should be shown that by intelligent firing, resulting in saving coal, they save themselves much useless labor. The enginemen also should be shown how to work a locomotive in the most economical way and thereby save the firemen a great deal of labor. Here again it is necessary that friendship and co-operation exist, and therefore great care should be given to the assignment of engine crews. Third, it should be demonstrated by frequent tests with different locomotives and trains, both freight and passenger, just what amount of coal is necessary for a trip, and there should be placed on the tender of each locomotive a limited amount for each trip, with a few additional tons to take care of extra cars, unusual delays, bad weather conditions, etc. It is the practice of every railroad to have a schedule of oil allowance, and I see no reason why a similar schedule cannot be used successfully with regard to the fuel. There is no need of weighing the coal; all that is necessary is to have marks on the sides of the tank from one-half ton up and then fill up to the mark which designates the amount necessary to supply the locomotive over the division or to the next coal tipple. If an engine crew has a certain amount of coal with which to make a trip, they will naturally be economical from the start. Of course if the limited allowance is not sufficient for some crews, the engineman could make out a coal check and get the extra amount he desires at one of the coaling stations, for by no means should there be a loss of time on any train; then after the trip is completed the engine crew should explain why they used more coal than the regular allowance, and from their statements and the trip itself it can very readily be determined where the fault lies. It does not follow that the crew should be disciplined, but their attention should be called to the matter, for their inability to produce the required results signifies that they are either careless and in need of further instruction, or else they are not properly mated, and to insure success the engineman must co-operate with the fireman.

ROAD FOREMAN.

COAL SUPPLIES FOR THE BELGIAN RAILWAYS.—At present almost all the coal needed by the Belgian state railways is, by law, supplied by Belgian collieries. The railway administration contemplates the revival of the system of inviting public tenders, which, if adopted, would probably result in considerable quantities of coal being obtained from Great Britain, as was the case until about two years ago.

# "GETTING MORE MOVEMENT FOR FREIGHT CARS."

Experienced Transportation Men Discuss Arthur Hale's Recent Article, and Suggest Methods for Increasing Efficiency.

## A PROBLEM FOR ALL OPERATING OFFICERS.

By E. H. DE GROOT, JR.,

Superintendent of Transportation, Chicago & Eastern Illinois.

The fact that confronts the transportation officer is that any remedy for delays to cars while in the possession of the railways for movement lies within his own hands. No man can afford to deceive himself and Arthur Hale in his article on "Getting More Movement for Freight Cars" in the *Railway Age Gazette* of August 1 has clearly pointed out the lines along which investigation should be directed in the endeavor to expedite the movement of freight equipment. "Getting more movement for freight cars" is only one phase of the car efficiency problem, but it is a big one and can only be solved by securing definite information as to conditions and acting upon such information.

Any attempt to increase the activity of the equipment without active co-operation by the superintendent will be futile. This was probably Mr. Hale's idea when he called attention to the fact that the best way to reduce the number of cars left in yards "Is to bring the facts home to everyone concerned, i. e., to everyone who can help."

The superintendent is the key to this situation. If he does not take a personal interest in the subject, the rest of the division organization will never be more than luke-warm. If he is active, his activity will be multiplied to the extent of the entire organization, notwithstanding that in this day of specialization, there is a tendency to confine the interest of the individual officer or employee within well defined limits.

As a matter of fact, there is no reason why the division engineer, master mechanic, road foremen and every other man on the division pay roll should not be actively interested in car movement. A superintendent told me not very long ago that a stenographer, new to him, but acquainted with the road, suggested that he (the superintendent) had made a mistake in instructing that certain data regarding car mileage be sent to the division engineer in addition to other members of his staff. The reply was that the division engineer is as much a member of the car department as the car distributor. This is the spirit which will go far in bringing about the necessary results.

With the superintendent so interested that he will enthuse agents and yard masters, as well as train masters and other officers, in the development of actual conditions for which they are personally responsible, much better results will be secured than where a man from the general office brings these conditions to light, and so places the division and local men on the defensive.

Mr. Hale has well said that increasing the speed of freight trains as a means of getting more movement for freight cars is not a factor. Anyone who has not analyzed freight car movement will be surprised to find how fast the cars travel when once they are placed between a road engine and caboose.

Conditions at each interchange point, yard and station should be carefully analyzed. Sometimes false switch engine economy delays cars on connections as well as in yards and on team, industry and repair tracks. It is not hard to find the line beyond which it is false economy to reduce the number of switch engines worked, and this line should be carefully established.

Delays for inspection, the set-back evil, delays for billing from delivering line, etc., all suggest their own remedies. The work of yard clerks, bill clerks and car inspectors has

an important bearing upon the expeditious handling of cars in yards. These delays multiply, of course, with the number of yards through which a car must pass in making a given trip, and Mr. Hale states the case in a nut-shell when he says, "The problem for the transportation departments of the country then, during the next car shortage, is to reduce the delays to cars in yards."

I take it that he makes this statement in its broad sense, and intends it to cover the local stations also. An analysis of delays at these stations emphasizes the dependence of such points upon local freight trains for both switch and road movements, trains which do not run on Sundays and legal holidays.

Agents can keep down delays to foreign cars by regularly reporting them for disposition as soon as received under load, and car distributors should give disposition to agents in time for incorporation into switch list for the first local train in the direction involved. Local freight crews should make delivery of cars in their trains to intermediate connections even though they may have met the opposing local train which is required to do work at that station.

These points are merely suggestive. Investigation, analysis and the application of the remedies suggested by the conditions found will increase car activity. The work will never be finished, but substantial progress will result from eternal vigilance.

## METHODS USED TO INCREASE CAR EFFICIENCY ON SUNSET-CENTRAL LINES.

By F. M. LUCORE,

Assistant General Manager, Sunset-Central Lines.

Much can be accomplished by railway men in car handling by discussing ways and means for reducing railroad detention and forgetting for the moment to discuss ways and means of reducing so-called shippers' and consignees' detention. Some of the methods in effect on the Sunset Central Lines to bring about good car handling are as follows:

(1) We secure written orders from shippers on form provided, setting forth the number of empty cars required.

(2) We place empty cars on definite orders, and keep the remainder in stock. In other words, we are breaking away from the practice of placing empties before they are ordered by the shipper.

(3) We take empty cars from stations which have no unfilled written orders, and move them to stations which do have such orders.

(4) We freely accept cars in interchange from connecting lines. If the cars are tendered to us in bad order we repair them. In addition, we advise the delivering line, giving details. This has had the effect of causing the inspection of cars to be materially tightened up before they are tendered to us. Less than 3 cars in 100 which we receive from connections have to be repaired.

(5) We urge connecting lines to let us know of each car which we tender to them that is either in bad order condition or without proper data for forwarding in order that we may, in turn, prevent a recurrence.

(6) We aim to have loaded cars moved through terminals in the order of their arrival.

(7) We examine the records to ascertain how promptly, on arrival at destination, cars are placed where they can be unloaded. This is no small task, but it pays.

(8) We cease supplying empty cars with which to handle

shipments destined to consignees who are already overstocked with loads which they are unable to release.

(9) We commend yard clerks, yard masters, freight conductors, local agents, chief dispatchers and others for good work performed in car handling.

(10) We have sufficient traveling agents to cover each operating division, and two inspectors of transportation to supplement the work done from the division and general offices.

(11) In conclusion, everybody on the Sunset-Central lines, from the president down, is a car man.

It is to be hoped that Arthur Hale's splendid article, entitled "Getting More Movement for Freight Cars," appearing in the issue of the *Railway Age Gazette* for August 1, will stimulate all of us to study more diligently into the car handling problem to the end that such efficiency as is possible within ourselves may be secured. Then it is believed that such help as may be needed from the public can also be secured.

### ATLANTIC TYPE INSPECTION LOCOMOTIVE.

The Philadelphia & Reading has recently designed and built at the Reading shops three Atlantic type locomotives for inspection purposes. The Atlantic type was selected in order to obtain the large grate area desired. The boiler shell is very small in diameter so that it fits between the wheels and is so located that the center of the boiler barrel is only slightly above the top of the drivers. A small wash room is provided in the cab and the fittings throughout are heavily nickel plated, giving the loco-

motive a very attractive appearance. No provision is made for operating the locomotive from the observation room, but push buttons are provided for attracting the attention of the engineer, and there is an emergency brake valve in each front corner of the observation room. While the locomotive normally is operated alone, it has sufficient tractive effort to haul one or two private cars on a good schedule.

The firebox is of the Wooten type and the crown sheet is on a level with the top of the firedoor. The size of the grate is large, there being an area of 63 sq. ft. provided. The usual combustion chamber is arranged ahead of the firebox and the brick wall is used in the normal position. This leaves space for 14 ft. tubes, of which there are 180, 1 3/4 in. in diameter, giving 1,154 sq. ft. of heating surface. The dome is so located as to be included in the engineer's cab and it could be made as large as desired. It is 27 1/2 in. in diameter or considerably more than half as large as the barrel of the boiler and measured 34 in. in total height. This will insure dry steam, although it is located directly above the hottest part of the crown sheet. No superheater has been applied. It will be noted in this connection that the crown sheet is very largely supported by sling stays, there being but seven rows of radial stays at the back. Flexible staybolts have been put in the breakage zone on both side sheets. A steam pressure of 225 lbs. is carried.

Underhung spring rigging was necessitated by the relative positions of the frames and boiler shell. This is arranged to be continuous on each side for the drivers and trailing wheels, there being four semi-elliptical springs in each set.

The cylinders are 18 in. by 24 in. and are separate from the saddle casting and the single bar front rail of the frame is en-

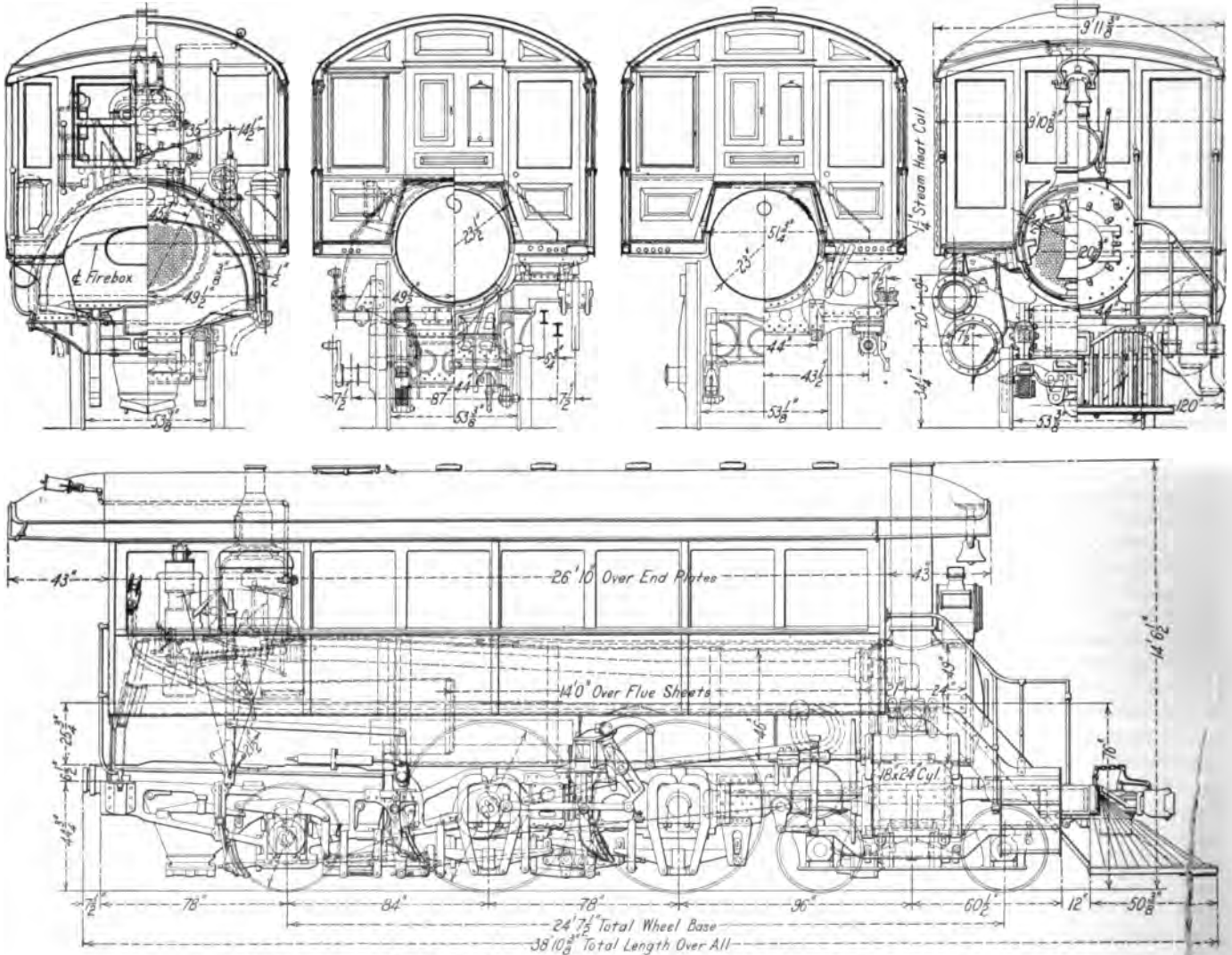

General Arrangement of the Philadelphia & Reading Inspection Locomotive. Digitized by Google

closed between the two; 11 in. valve chambers are set 7½ in. outside of the cylinder centers and the outside steam pipe extends from the side of the smoke box, underneath the floor of the observation room, to the top of the steam chest in nearly a horizontal line.

The valve gear is of the Walschaert type with the link supported by a casting extending between the two drivers. Owing to the location of the boiler, it is not possible to carry the lift shaft across the locomotive in a straight line. Furthermore, there is no clearance for an upwardly extending arm on this

in a vertical direction, it was necessary to arrange the screw itself to take different angles, depending on the position of the lever. This has been done by carrying the whole screw operating gear on a pinion supported by a casting on the boiler head. At the front end the screw has only a guide to keep it in line. The hand wheel is connected to the screw itself by a train of gears which not only increases the leverage of the wheel, but also brings it in a more convenient location for handling.

Provision for heating the observation room is made by means of steam pipes under the floor. A small turbo generator is provided for supplying current for the electric lights. One of the illustrations shows the interior of the observation car, giving a good idea of the clearness of vision which can be obtained on all sides.

General dimensions, weights and ratios of this locomotive are given in the following table:

<i>General Data.</i>	
Gage .....	4 ft. 8½ in.
Service .....	Inspection
Fuel .....	Anthracite
Tractive power .....	21,700 lbs.
Weight in working order.....	161,500 lbs.
Weight on drivers .....	98,375 lbs.
Weight on leading truck .....	26,775 lbs.
Weight on trailing truck.....	36,350 lbs.
Weight of engine and tender in working order.....	299,500 lbs.
Wheel base, driving .....	6 ft. 6 in.
Wheel base, total.....	24 ft. 7½ in.
Wheel base, engine and tender.....	53 ft. 5½ in.

<i>Ratios.</i>	
Weight on drivers ÷ tractive effort.....	5.13
Total weight ÷ tractive effort.....	8.41
Tractive effort X diam. drivers ÷ heating surface.....	1,032.0
Evap. heating surface ÷ grate area.....	20.22
Firebox heating surface ÷ total evap. heating surface, per cent....	10.61
Weight on drivers ÷ total heating surface.....	77.20
Total weight ÷ total heating surface.....	126.7
Volume, both cylinders, cu. ft.....	7.06
Total heating surface ÷ vol. cylinders.....	180
Grate area ÷ vol. cylinders.....	8.92

<i>Cylinders.</i>	
Kind .....	Simple
Diameter and stroke.....	18 in. x 24 in.

<i>Valves</i>	
Kind .....	Piston
Diameter .....	11 in.
Greatest travel .....	7 in.

<i>Wheels.</i>	
Driving, diameter over tires .....	68¾ in.
Driving journals, main, diameter and length.....	8¾ in. x 12 in.
Engine truck wheels, diameter.....	33 in.
Engine truck, journals.....	5½ in. x 10 in.
Trailing truck wheels, diameter .....	42¾ in.
Trailing truck, journals.....	7 in. x 12 in.

<i>Boiler.</i>	
Style .....	Wooten
Working pressure .....	225 lbs.
Outside diameter of first ring .....	46 in.
Firebox, length and width.....	108 in. x 84 in.



Interior of Observation Room Looking Towards the Rear.

shaft for connecting with the reverse lever. An arrangement has therefore been made whereby the reach rod from the reverse lever connects to the arm on a shaft bolted on the frame just ahead of the firebox. This shaft extends inward to the center of the locomotive, where it has a downwardly extending arm to which a bifurcated reach rod is connected that connects to the downwardly extending arm at the center of the lift shafts for each side of the locomotive. This rod spans the axle of the rear driver.

One of the most interesting features of the whole design is the combination lever and screw reverse gear that has been provided. The arrangement is such that the engine can be reversed by a lever in the ordinary manner, or if desired it can be ad-



Atlantic Type Inspection Locomotive Designed and Built by the Philadelphia & Reading.

justed by a screw gear. This combination has been accomplished by having the nut which meshes with the screw cover but the upper half of its circumference. It is set in guides formed by the sides of the reverse lever which span the screw and is connected to the latch by links so that it can be lifted, the screw acting as a quadrant when the lever is being moved by hand. When it is latched, however, the turning of the screw will move the lever to any desired point. As the lever swings from a stationary fulcrum and the screw block in the lever cannot move

Tubes, number and outside diameter.....	180—1¼ in.
Tubes, length .....	14 ft.
Heating surface, tubes.....	1,154 sq. ft.
Heating surface, firebox.....	120 sq. ft.
Heating surface, total.....	1,274 sq. ft.
Grate area .....	63 sq. ft.
Smokestack, height above rail.....	14 ft. 6½ in.
Center of boiler above rail.....	76 in.

<i>Tender.</i>	
Frame .....	12 in. channel
Wheels, diameter .....	36 in.
Water capacity .....	6,000 gals.
Coal capacity .....	9.75 tons.



## E. P. RIPLEY ON CAR SHORTAGES.

E. P. Ripley has sent the following letter to the *Chicago Examiner* in reply to an editorial on car shortages, published in that paper:

"Your editorial indicates that car shortages occur in this country every year, that the public cannot understand why this is the case, and that an explanation of the matter is due from railway officers. Since you have raised the question of the reason for car shortages, I have no doubt that, in a spirit of fairness, you will give me space in which to answer.

In the first place, you are in error in implying that car shortages occur annually. There were net shortages in 1907, 1909 and 1912, but there were none in 1908, 1910 or 1911, so that in one-half of the last six years there have been no net shortages.

"Secondly, car surpluses are much more common in the United States than car shortages, and become much larger. There are always shortages in some parts of the country and surpluses in other parts of the country because it is impossible to move cars so as always to have them just where they will be needed next. If the total shortage exceeds the total surplus there is a net shortage, and if the total surplus exceeds the total shortage there is a net surplus. The American Railway Association between January 2, 1907, and July 15, 1913, made 162 fortnightly reports regarding car shortages and car surpluses, and 139 of those reports showed net surpluses of cars while only 23 showed net shortages. In other words, there have been surpluses of freight cars six-sevenths of the time during the last six and one-half years. Furthermore, the net surpluses reported greatly exceeded the net shortages. The largest net shortage reported in 1907 was 137,847 cars, while on April 19, 1908, there was a net surplus of 413,000 cars. The largest net shortage in 1909 was only 5,740 cars, while the largest net surplus in that year was over 330,000 cars. The largest net shortage in 1912 was 51,112 cars, while the largest net surplus was almost 136,000 cars.

"Since the railways during the last six and one-half years have supplied more cars than there was a demand for six-sevenths of the time, the question naturally arises as to why they have not been able to furnish enough cars the other one-seventh of the time. The answer is to be found in the figures showing the violent fluctuations in the amount of freight traffic that is offered to them to handle at different parts of the year. The statistics for 1912 are fairly typical of those of a year of car shortage. In January of that year the earnings of the large railways from freight traffic as reported by the Interstate Commerce Commission were less than \$141,000,000, and on January 17 there was a net surplus of over 90,000 cars. In October of the same year the freight earnings of the same roads were almost \$211,000,000, or about 50 per cent. greater than they were in January, and on October 24 there was a net shortage of about 50,000 freight cars. The average earnings per month for the year were \$169,500,000 and the average net car surplus, or average safety margin, was 33,335 cars; the maximum volume of business was thus 24 per cent. greater than the average volume. Is there anything very mysterious about the inability of any concern to deal satisfactorily with its maximum business when its maximum monthly business exceeds its minimum monthly business by 50 per cent.? Obviously, if it provides enough facilities to handle its maximum business promptly and satisfactorily it will have a large surplus capacity when only its minimum business is offered.

"Perhaps it may be contended that the railways should provide so much equipment that they could promptly supply a car to every man who ordered it even in the season of the heaviest movement of traffic. But if they did this they would have to make a large additional investment. They would have to earn a return on this investment, and those to whom the cars were supplied would have to pay rates sufficient to yield a return on the additional investment. That the present rates are not sufficient to earn a return on an enormous additional investment is shown by the fact that the average rate of dividend paid on all railway stock outstanding in the year ended June 30, 1912,

was only 4.7 per cent., while the average rate of interest paid is slightly less than 4 per cent. The question for the people of the country to consider is whether they are willing to pay what must necessarily be spent in order to provide cars enough promptly to move the maximum business that is offered. Thus far they have not shown a disposition to pay enough to enable the railways to supply the additional equipment that would be required to do this.

"But over and beyond the question of increased cars is the question of increased number of locomotives to move them, increased terminals and trackage for them to stand on, and above all increased forces of men to run the engines and handle the trains. It is manifestly impossible to vary the forces of men 50 per cent. each year with the fluctuations of traffic, and this problem, difficult as it is under ordinary conditions, has been rendered far more difficult by the absolutely useless full crew legislation which has been passed in many of our states.

"The car shortages in this country are usually discussed as if similar conditions were uncommon in other countries. This is not the fact. There repeatedly have been severe car shortages in recent years on the German railways, which are owned by the government. There was one in 1912 which began in August and lasted until the end of the year, and the situation finally became so acute that the state railway administration stopped all traffic on the west bank of the Rhine for four days. The German shippers have complained bitterly about these car shortages, but a high officer of the Prussian State Railways was quoted in a cable despatch from Berlin on December 7, 1912, as saying that "the state cannot invest undue amounts of capital where it will have to lie unemployed for the greater part of the year." Likewise, in recent years there have been severe car shortages on the railways of Australia, which also are owned by the governments. Regarding the situation in New South Wales the *Sydney Sun* said in its issue of February 12, 1912: "As each harvest comes round the position is more intensified. The trade is actually paralyzed and the future is viewed with dismay." The chief sufferers from the car shortages in Australia have been the shippers of agricultural products. There was a severe shortage of cars in Canada in the fall of 1912, and a recent elaborate report of the British Board of Trade on the operation of the railways of the various European countries shows that there are also complaints of shortages of cars in France, especially on the government railways; in Italy on the government railways; and in Austria-Hungary on both private and state railways, but especially on the latter.

"In other words, car shortage is almost a world-wide condition, and complaints of it are especially rife in countries where industry and commerce are expanding and railway traffic is increasing rapidly. Doubtless in most other countries, as in the United States, car shortages are due chiefly to the wide fluctuations in the amount of freight traffic at different periods of the year, and the evidence indicates that, however regrettable they may be, the shortages in this country are neither as numerous nor as large in proportion as they are in some other countries, as Germany, for example.

"If our law-makers would stop the stream of expensive and useless legislation which is being poured out in such floods upon the railroads and see what the effect is of regulation by the commissions and the courts, there is little doubt in my mind that railroads would steadily expand their facilities and increase their equipment so as to make any widespread car shortage less and less a likely possibility. A great part of the trouble in the past and the possibility of danger in the future lie not in failure of railroads to foresee and anticipate the needs of the country, but in the inability to raise money to provide facilities on account of the destruction of railway credit by hostile legislation."

**COLLAPSE OF ITALIAN RAILWAY BRIDGE.**—A railway bridge in course of construction near Genoa, Italy, collapsed on August 19, with the result that two men were killed and ten other persons were injured.

# NEW OHIO RIVER BRIDGE AT KENOVA, W. VA.

## Replacing of Five Span, Double Track, Through Truss Structure on Same Piers Without Interrupting Traffic.

The old bridge which carried the Virginia and Ohio line of the Norfolk & Western over the Ohio river at Kenova, W. Va., and which has just been replaced, was built in 1891-2. It was 3,942 ft. long and consisted of five river spans, one 518 ft. long and four 298 ft. long, and a 2,210 ft. steel trestle approach on the east end. A minimum clearance of 40 ft. above extreme high water was required for navigation, making the four river piers nearly 100 ft. high. These piers were built of sandstone and local freestone. The bridge was built for a single track, but the trusses were spaced 34 ft. center to center, with the intention of adding a second track in the future by placing a third truss between the two original ones. This was never done, although when the line was double tracked east of Kenova,

operating qualities of the line. In addition to these considerations, the old piers were still in excellent condition and a considerable saving in the cost of the structure was made possible by their use.

In order to build the new bridge on the old alignment without interruption to traffic it was necessary to erect the new trusses outside of the old, and although the old bridge was of unusual width on account of the provision for the middle truss, the new bridge had to be made still wider. The piers which had a minimum length of 45 ft. over copings, sufficient for an ordinary double track bridge, were not long enough to carry the end bearings of the new trusses in the usual manner. On account of the fact that the river at this point is deep, the



Fig. 1—The Old Norfolk & Western Bridge at Kenova.

two gauntleted tracks were laid on the structure. As there are 60 to 70 train movements a day over this portion of the line, it was very important that the capacity of the bridge be increased by adding a second track, and it was necessary to accomplish this without interrupting traffic.

### THE OLD BRIDGE.

The old bridge was designed for Cooper's E-40 loading, the steel being heavy enough to carry two tracks if the third truss had been placed according to the original design. For present loadings, however, and the prospective increase in such loadings which must be taken into account in bridges built today, some strengthening of the bridge would have been necessary in any permanent improvement, and it was decided that it would be more advisable to build an entirely new double track structure.

current swift and the piers high, it was not thought advisable to incur the expense of lengthening them, so special pier girders were designed to carry the bearings of the new trusses on cantilever arms. These girders are necessarily very deep, and as there was to be practically no change in grade on the bridge, it was necessary to cut off the tops of the old piers to provide clearance for the girders below the bottoms of the trusses. These changes involved some rather unusual substructure work and a number of interesting problems were encountered in the erection of the superstructure.

### DESIGN OF NEW SUPERSTRUCTURE.

The new bridge has the same span lengths as the old, 518 ft. and 298 ft., respectively, the trusses being spaced 43 ft. cen-

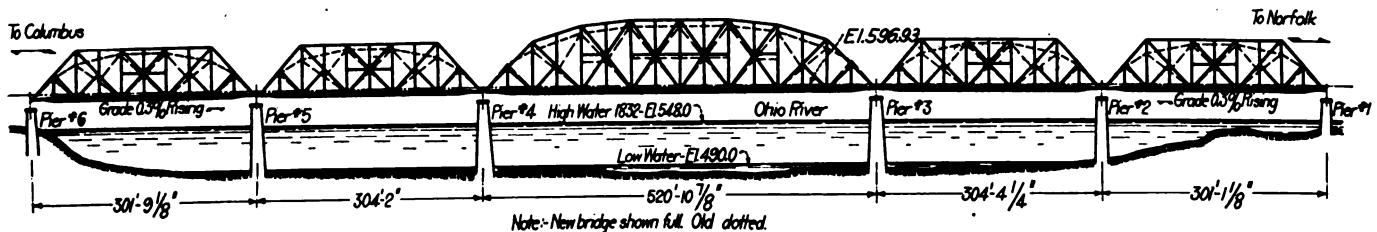

Fig. 2—General Elevation of New and Old Bridges.

No change in location was feasible, as the present alignment approaching the bridge on the east is very good and any change would have involved the purchase of improved property in the city of Kenova at a high price. It would have been practically impossible to have made any line change which would not have introduced considerably more curvature, and thereby injured the

ter to center. Two assumed loadings were used in the design of the superstructure. The first assumed in the design of the trusses a uniform load of 8,500 lbs. per lineal feet per track, with the addition of two concentrations of 70,000 lbs. each, spaced about 30 ft. center to center; for the floor beams and hangers 8,500 lbs. per ft., with eight 85,000-lb. axles; and for the

stringers 8,500 lbs. per ft., with five 85,000-lb. axles. The impact in all parts of the structure for this assumed loading was

added in accordance with the formula  $I = \frac{300}{L + 300}$ . The ten-

sile strength in steel was assumed as 62,000 to 70,000 lbs. per sq. in., and in rivet steel 47,000 to 55,000 lbs. per sq. in. The permissible fiber stresses were as follows:

Tension, 20,000 lbs. per sq. in. (including dead, live and impact stresses).

Tension, 24,000 lbs. per sq. in. (including dead, live, impact, wind and secondary stresses).

Compression, 20,000 lbs.— $100 \frac{L}{R}$ .

Extreme fiber stress on pins, 30,000 lbs. per sq. in.  
 Shear on shop rivets and pins, 15,000 lbs. per sq. in.  
 Shear on air driven field rivets, 14,000 lbs. per sq. in.  
 Shear on hand driven field rivets, 12,000 lbs. per sq. in.  
 Shear on plate girder webs, 12,000 lbs. per sq. in.  
 Bearing on shop rivets and pins, 30,000 lbs. per sq. in.  
 Bearing on air driven field rivets, 28,000 lbs. per sq. in.  
 Bearing on hand driven field rivets, 24,000 lbs. per sq. in.  
 Bearing on masonry, 600 lbs. per sq. in.

The design as computed from the above assumptions was compared with the results secured from Cooper's E-60 loading, combined with the allowable unit stresses given in the specifications



Fig. 3—Placing a Pier Girder Under Old Span after Cutting Away Half of the Top of Old Pier. The Right Hand Span Is Supported Temporarily by the Gallows Frame.

of the American Railway Engineering Association of 1910 and for a given member the maximum stress found by these methods was used in the design.

The new bridge is laid with 100-lb. rails on the westbound track and 85-lb. rails on the eastbound, white oak ties being used throughout. A special form of rail anchor is used on the viaduct approach which consists of two bent plates, one bolted to the top flange of the track girder and the other to the web of the rail, the two being joined by an insulated connection. This anchor has proved very efficient in preventing rail movement on this approach viaduct. The new bridge was painted with one shop coat of red lead and two field coats of carbon

black. The work of cutting down the old piers was begun in April, 1912, and the erection of the new steel was begun in June.

#### ALTERATIONS TO OLD PIERS.

The old stone piers had to be cut down about 8 ft. to allow the placing of the new pier girders, but as there was a difference in the elevation of the old piers of about 1 ft. 7 in., and the courses of stone varied in thickness from 16 in. to 22 in., this total cut was somewhat irregular. On five of the piers five courses of stone were removed, and on the sixth pier four courses were taken off. The total cut varied from 6 ft. 9 in. to 8 ft. 3 in., the average being 7 ft. 10 in. The girders on piers 3 and 4 supporting the central span are 5 ft. deep. The other

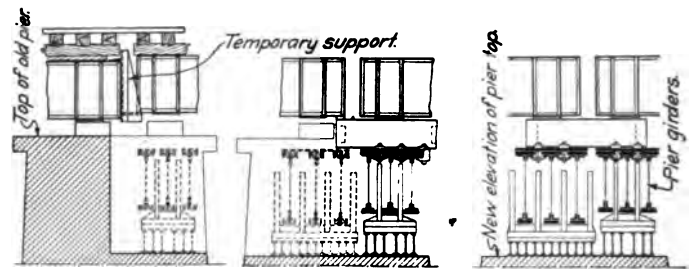

Fig. 4—Sequence of Operation In Cutting Down Piers Without Interference to Traffic.

girders supporting the 298 ft. spans are 4 ft. 3 in. deep. The tops of all of these girders were located a uniform distance below the base of rail and on account of the variation in the elevation of the piers and the difference in depth of girders, a number of combinations of plates and I-beams had to be used under the cast steel pedestals supporting these girders. The distance from the bottom of pedestals to the top of masonry varied from 3 ft.  $\frac{7}{8}$  in., to 2 ft.  $\frac{1}{8}$  in. For depths less than 1 ft. a combination of plates was used under the pedestals and for depths more than 1 ft. 10 in., 12 in. or 20 in. I-beams were used with plates as required.

The removal of the tops of the old piers made it necessary to reinforce the new tops in some manner to take the place of the coping which was removed. A new concrete coping was built around the piers at the elevation of the new top before the top courses were removed, this coping extending down three courses below the shoes of the pier girders. The old piers 1, 2, 5 and 6 were 12 ft. wide and 45 ft. long over the coping, and piers 3 and 4 were 14 ft. wide and 48 ft. long. The new concrete coping for the smaller piers is 13 ft. 6 in. x 46 ft. 6 in., and for the larger piers 15 ft. 6 in. x 49 ft. 9 in., a minimum thickness of 16 in. of concrete being allowed over the stone on the sides of all of the piers, and 18 in. on the ends. A 1:2:3 concrete mixture was used in these copings.

Three sets of reinforcement were provided in these belts. The first consists of six 2 in. bolts through each pier, set in holes drilled through the first and third stone courses below the new top of masonry. These are arranged in three pairs, each pair being connected by a 1 in. plate 6 in. wide. Each bolt is threaded 18 in. on each end and allowed to project into the concrete. Three hexagonal nuts are used on each end, one holding a 6 in. x 6 in. x  $\frac{1}{2}$  in. plate tight against the stone, and the other two holding the plate connecting each pair near the end of the bolts. Just outside of the ends of these bolts is the second set of reinforcement, which consists of  $\frac{3}{4}$  in. square bars set vertically on 12 in. centers. These bars are bent in at the bottom to form the surface reinforcement for the lower portion of the belt. The third set of reinforcement, which consists of 1 in. square bars on 6 in. centers placed horizontally entirely around the piers, is located just outside of the vertical bars. The lower portion of these concrete courses was placed up to the new top of masonry before the piers were cut, as shown by the dotted lines in the accompanying drawing. After the erec-

tion of the steel, the concrete was carried over the top of the stone masonry and filled in around the shoes and pier girders as shown in the cross sections herewith. The vertical reinforcement in the lower portion of the belt was allowed to extend above the concrete placed in the first operation and the bars forming the surface reinforcement for the upper portion were lapped over these. Horizontal reinforcement was provided in the top portion of the coping similar to that described above. The concrete over the pier girders is bonded to that between the webs by short sections of 1 in. bars set vertically, and it is surface reinforced by ½ in. bars in both directions. The

girders which are on the two long piers, 34 ft. 9 in., and for the smaller girders 32 ft. 9 in. As the new trusses are 43 ft. center to center, the amount of cantilever at each end of the heavy girders is 4 ft. 1½ in., and for the smaller ones 5 ft. 1½ in. The girders are of very heavy construction, being built up with three webs, their depths as mentioned above being 5 ft. and 4 ft. 3 in., respectively.

GALLOW'S FRAME FOR SUPPORTING OLD TRUSSES.

During the removal of the top courses of the old piers the old trusses were supported by a gallow's frame, consisting of

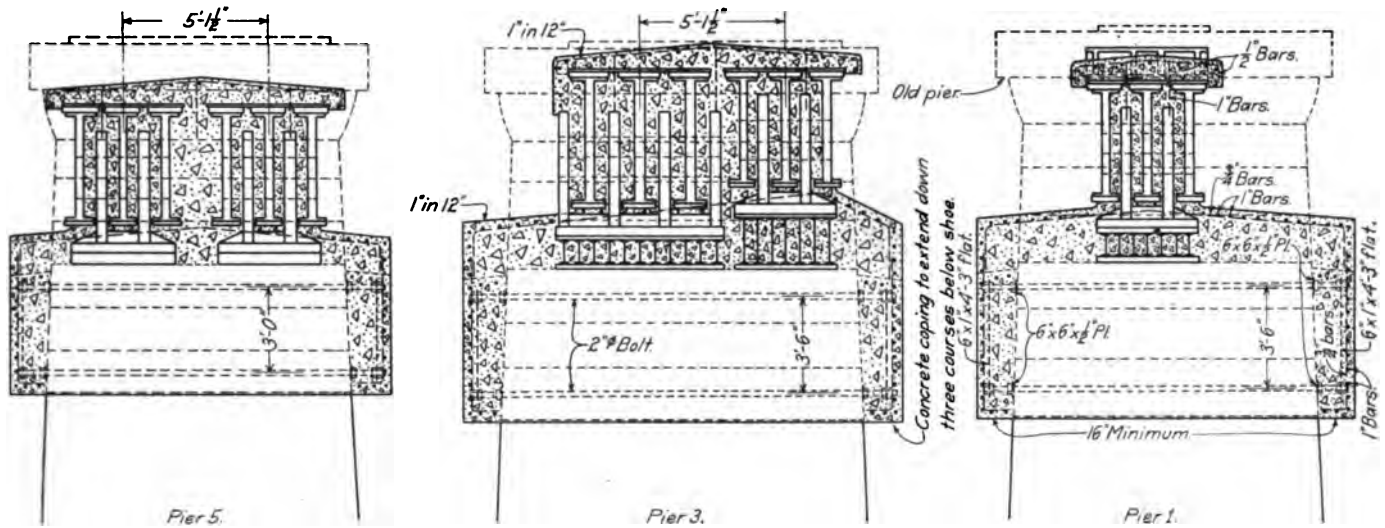

Fig. 5—Sections of Three of the Piers Showing Alterations Made in Cutting Off Old Tops.

upper surface of this concrete is battered 1 to 12 transversely in both directions from the centers of the piers.

The smaller girders are supported on cast steel pedestals having a bearing surface of 3 ft. 10 in. x 8 ft., and the larger ones on pedestals whose bearing surface is 6 ft. x 9 ft., the latter having four vertical ribs for the pin bearing. The pins in both cases are 18 in. in diameter. The outer edges of all the pedestals are thus placed about 1 ft. from the end of the old stone piers, making the distance center to center of pins for the large

two built up columns supporting a transverse plate girder with diagonal bracing to give lateral stiffness. Near the top of these columns, hanger bars were connected to support the trusses to be raised. The posts were arranged to take a bearing on the end pins of the trusses adjacent to those which were to be raised, the tops of the posts being inclined towards the truss to be moved so that when they were pulled toward the vertical the truss would be raised off its bearings by means of the hanger bars described. In most cases the bearing for these gallow's frame posts was secured by rearranging the packing on the end



Fig. 6—End View from South Showing Material Tracks and Electric Hoist for Raising Materials to the Bridge from the Ground.



Fig. 7—Old Span 1 Showing False Work Carrying Traffic and Small Traveler Erected on Old Trusses to Place New Span.

pins so as to insert the bearing plates attached to the bottom of the posts. In some cases, however, instead of using bearing plates on the bottom of the posts, short transverse girders were attached to the posts a few feet from the bottom, which were supported by a short column at each end connected to bearing shoes placed on each side of the main truss shoe of the span

vide a bearing for the gallows frame posts, this bearing was secured by erecting double timber bents back of the piers and placing blocking from the caps of these bents to notches cut in the stone piers on which the bearing shoes of the gallows frame were set. For pier one the gallows frame was guyed to the approach viaduct. It required 130,000 lbs. tension in the six lines to lift this end span.



Fig. 8—New Span 1 After Removal of Old Trusses Showing Heavy Traveler Erected for Placing Spans 2 and 3.

At the intermediate piers half of the masonry was removed at one operation. The gallows frames were first set on one truss and used to raise the other, while the longitudinal half of the stone pier under the truss thus supported was cut away. The pier girder for this location was then brought out in the river on an old car ferry and hoisted into place by falls from the transverse girder of the gallows frame, outhaul lines being attached to a floor beam of the old structure to hold the girder away from the pier. The smaller girders weighed 87 tons each and required one hour to place. The heavier ones weighed 127 tons each and required only a slightly longer time to place. When this first girder was in place on the new top of pier, the old span was blocked up on it at the proper elevation, the gallows frame was reversed so as to bear on the truss over the completed half of the pier, the other truss was raised, the remaining portion of the stone removed and the other pier girder placed.

adjacent to the one to be raised. The hanger bars were in two parts connected near their lower ends, allowing the lower section to be packed on the end pins of the span to be raised before the gallows frame was erected.

Special provision had to be made for supporting the end stringers during the removal of the pier tops at all intermediate piers. During the removal of the first half of the stone, the stringers bearing on that side of the pier were supported by plate and angle shelf connections from the ends of the corresponding stringers of the adjacent span which were still carried on their bearings on the undisturbed half of the pier. After the first girder had been placed the stringers were blocked up from these girders, and the shelf connections were reversed so that these stringers in their new position would support the stringers of the adjacent span while the stone was cut away below them. After the placing of the second girder these stringers were also

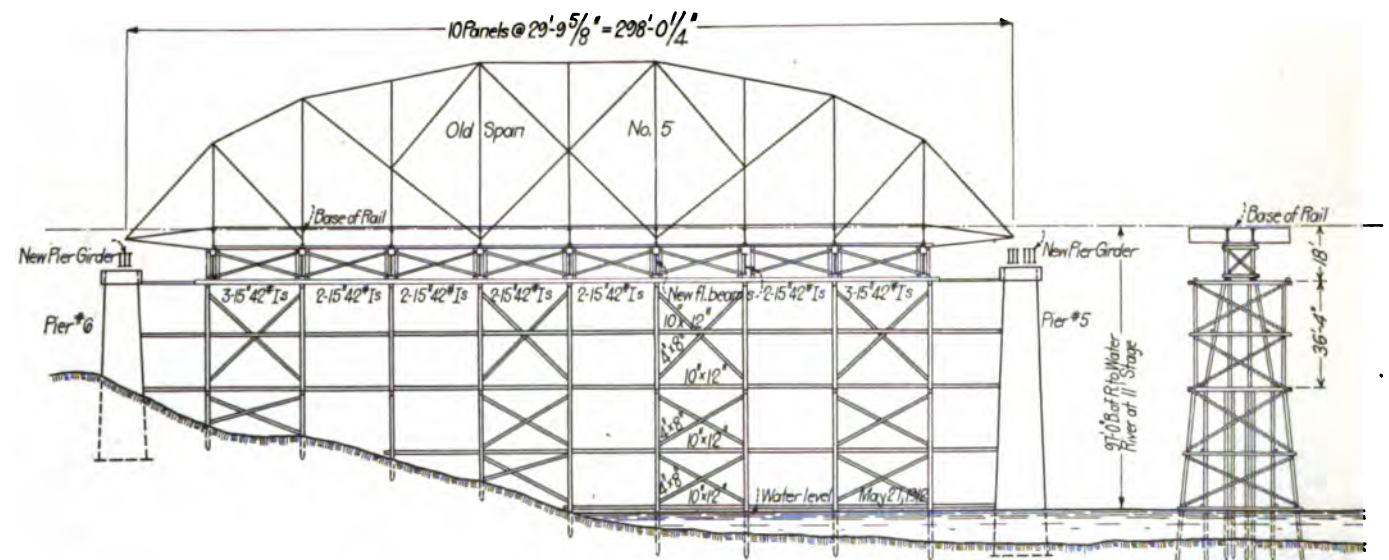

Fig. 9—False Work Used in Erecting End Spans Showing Pony Bents Supporting New Floor Beams.

span in the raised position. It was found in carrying out the work, however, that it was advisable to lower the truss for each train so that the gallows frame was never allowed to carry the truss under live load. A 100 h. p. electric hoisting engine was kept on the span to raise and lower the trusses as required, using a six sheave steel block attached to the top of the gallows frame. Blocking was kept ready on which to drop the trusses whenever necessary, and they were only raised about 1 in. between trains to clear the wedges.

carried by blocking from that girder and the temporary shelf connections were entirely removed.

METHOD OF HANDLING NEW STEEL.

At the end piers where there were no adjacent trusses to pro-

The superstructure of the five river spans required about 10,000 tons of steel and the approach viaduct required about 2,500 tons additional. All steel was delivered to a material yard on the south side, located on a belt line owned by the Norfolk & Western, around the city of Kenova. A stiff leg derrick of 40 tons capacity and a large traveler which was used in the

erection of the Queen & Crescent bridge at Lexington, Ky., were kept in this yard for handling material, unloading from road cars, assembling the parts and loading on material cars for transfer to the bridge. A material track connecting with this steel yard was built along the entire length of the approach viaduct and extended under an electric hoist which was used to raise the steel from the ground to the level of the bridge deck about 50 ft. above. This hoist consisted of two 2-drum, 4-spool engines, each having a capacity of 65 tons and mounted on separate gallows frames which spanned the material track on the ground and a spur track from the main line on the bridge level, being supported on timber bents built up from the ground. One of these frames was fixed and the other was arranged to travel along the supporting bents to allow the handling of pieces of any desired length. The engines also had a transverse move-

brackets from the new floor beams which were erected below the bottom chords of the new trusses. These connections of floor beams and material track brackets were made to temporary gusset plates dropped from the bottom chord. The stringers designed for the new bridge were used during erection in these material tracks, being supported directly on the cantilever brackets, and were transferred from this position in

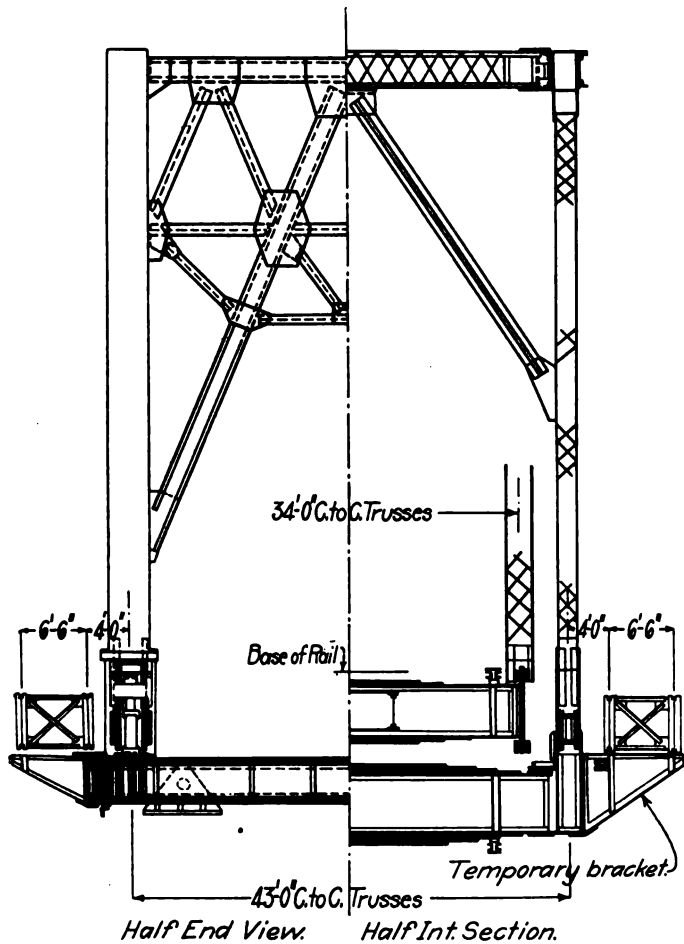

Fig. 10—Elevation and Section Showing Relation of New Bridge to Old and the Temporary Material Tracks Outside of Trusses.

ment on the girders of the gallows frames so that they could first be spotted over the track on the ground and after hoisting the load they could be moved over to a point above the track on the bridge deck, from which they could lower the steel directly to the material cars. The lighter material was brought up on flat cars, a number of which were provided with hanger stirrups for receiving the hooks from the falls of the hoisting engines. The heavy material was transferred from cars or trucks on the lower level to other cars or trucks on the bridge, the pieces that were too heavy for a car being carried on two standard trucks.

The spur track on the bridge level, which was served by the hoist, was connected to the main line just back of the end of the bridge and was also continued across the bridge outside the truss, a similar track being carried across outside of the other truss. These were supported on temporary cantilever



Fig. 11—Placing End Post of Span 2 by Cantilever Method Showing Erection Ties Between Spans 1 and 2.

the material track to their final position in the floor after the trusses were completely erected, by changing one or two panels at a time, depending on the allowable delay to traffic and the amount of time required to make the change. Since the floor beams were so far below their final position during erection, temporary struts had to be provided to brace the bottom chords against transverse buckling. The material tracks were built

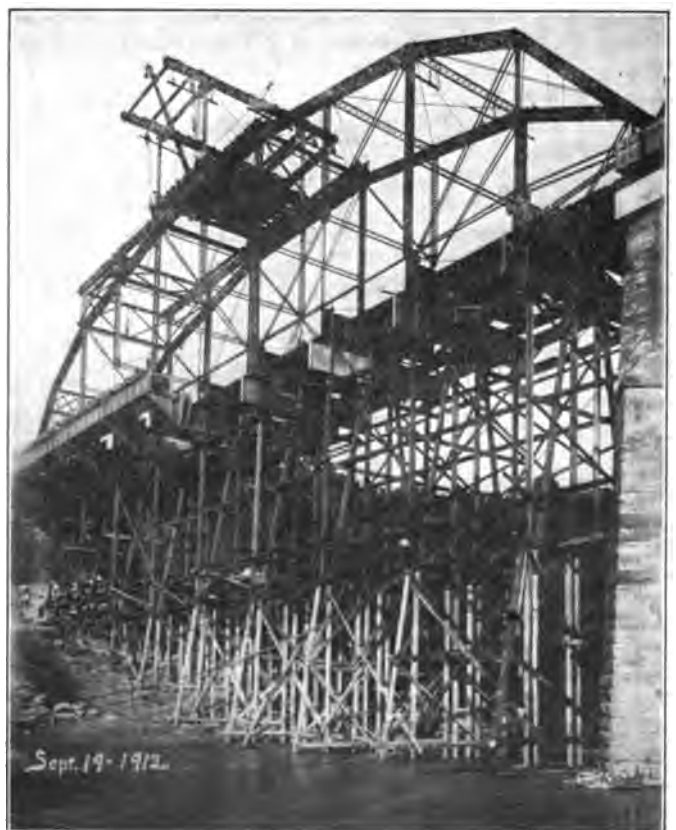

Fig. 12—False Work Under Span 5 Showing Connection of New Floor Beams to Old Ones and the Brackets Supporting Material Track.

from both ends of the bridge as the erection progressed, and connections with the main line were maintained at both ends so that steel brought up on the hoist could be run out on either side of the bridge from that end, or could be carried across the bridge on the main line and out on either material track from the other end. The movements of the dinky engine pushing these material cars were the only movements over the main track required for erection purposes.

Compressed air for pneumatic tools was supplied by a single compressor located on the east shore, the air being carried across the bridge in a 3½ in. pipe. Electric current for operating the motor equipment of the travelers and hoists was secured at 550 volts d. c.

The new steel was erected around the old without any interference with the old superstructure. In general, the bracing

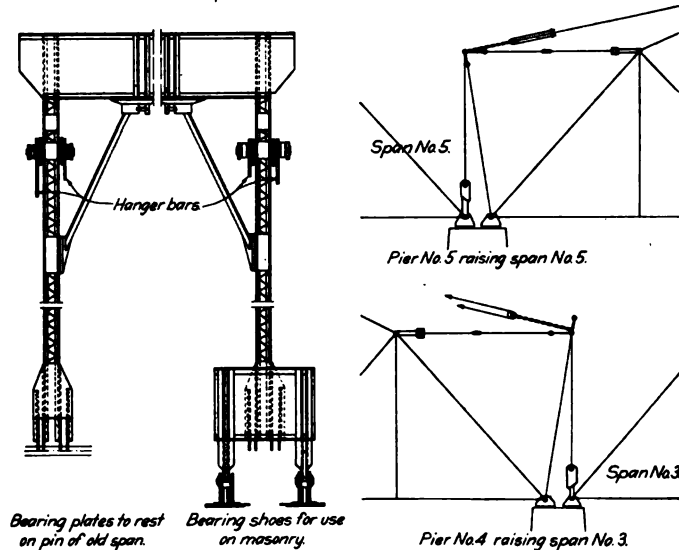

Fig. 13—Half End Views of Gallows Frame and Typical Diagrams of Operation of Lifting Spans.

was so designed as to clear the old steel 12 in. in all cases. Some very careful calculations of deflections of both the old and new trusses were necessary to make sure that this clearance would be secured. In some cases the design provided for the placing of temporary sway bracing, the material removed from old spans being remodeled to suit. These temporary members were kept in service until the old superstructure was entirely removed, allowing the placing of the permanent members.

#### ERECTION OF TWO END SPANS.

Spans 1 and 5 were erected by travelers placed on the top chords of the old trusses, falsework being provided to carry the live load, and the new span being supported on the old during erection. Bents of eight piles each were driven under the panel points to support framed bents 34 ft. wide at the top with a deck 18 ft. below the base of rail. On this deck two lines of four 15 in. 42 lb. I-beams were laid 8 ft. 6 in. apart center to center, on which were placed pony bents 10 ft. 9 in. high to support the ends of the old stringers. Two pony bents were placed at each panel point as near as possible to the floor beams and suitable longitudinal bracing was put in to connect the two bents under each panel. The stringers were blocked up on these bents and the rivets cut out of the floor beam connections so that all live load was carried through the stringers down into the temporary falsework. The new floor beams were then hung from the old by stirrup hangers of 3 in. rods with cross channels at the top and bottom.

Temporary timber falsework was used on the old trusses to keep the traveler track level. This was carried from the panel points of the old trusses and supported longitudinal I-beams on which the traveler track was laid. The traveler had a boom on

each end and also two cantilever arms extending over the material tracks on each side. Two falls were provided on each of these arms, one over the material track and the other over the center line of the new truss. A steel member to be placed was held by both lines, being picked up from the car on the material track by the outer one, drifted over to place and lowered by the inner one. The traveler was equipped with two 75 h. p. engines.

After the new floor beams had been hung, temporary brackets for the material track were attached to them and this track was laid continuously along both sides of the span. It was then possible to spot steel for the trusses on these tracks opposite its final location and the erection of the lower chord and web members proceeded continuously in this manner. Before the erection of the top chords and end posts, the new floor beams were blocked up on the caps of the timber falsework over the outside legs of the trestle so that the falsework would take the additional load imposed by the erection of the top chords and end posts. When the trusses were completed they were blocked up on their own bearings and the old stringers were blocked up on the new floor beams, allowing the new truss to carry the five load. The old truss was then dismantled, piece by piece, down to the floor system, the steel being removed over the material track. Work was carried on simultaneously on spans 1



Fig. 14—Erecting New Double Track Viaduct and Removing Old Members Without Interruption to Traffic.

and 5, duplicate travelers being used. Spans 2, 3 and 4 were erected by the cantilever method, the two shorter ones entirely from one end and the longer one from both ends. The heaviest member handled was the end post of span 3, which weighed about 108 tons. Spans 2 and 4 were erected simultaneously by two large travelers of a special design prepared for this bridge. Each of these travelers had two booms with a capacity of 65 tons each at a radius of 75 ft. They were equipped with two 4-drum, 8-spool hoists and 100 h. p. motors. The type of these travelers is well shown in the accompanying photographs. Adjustable legs at the rear of the travelers served to keep the masts vertical while working over the inclined top chords, a condition which is necessary to the successful operation of the revolving boom type of traveler.

## ERECTION OF SPANS 2, 3 AND 4.

After the completion of the two end spans, the small travelers used for these spans were left on the top chords of the new trusses as near the outer ends as possible. The large travelers for the cantilever erection of the three central spans were then erected on these new trusses just inside the small travelers which were left in that position during the erection of spans 2 and 4 to serve as counterweights. The end members of spans 2 and 4 and the temporary steel work connecting these spans with the shore spans were placed by the large travelers from the erection position on the end spans, after which they traveled out over the temporary work onto the top chords of spans 2 and 4 as the work progressed.

The connections of the hip ties from the trusses of spans 1 and 5 to spans 2 and 4 during erection were made by round pins and crescent shaped plugs in slotted holes so that when spans 2 and 4 were completed the outer ends of spans 1 and 5 respectively, could be jacked up, allowing the inner ends of spans 2 and 4 to rest on piers 3 and 4, thus removing the tension from the hip ties and allowing the crescent plugs to be driven out. Spans 1 and 5 could then be lowered and the temporary work between the spans removed. The closure of the 518 ft. truss erected from both ends was also accomplished by jacking up the outer ends of the adjacent spans, the difference in length of the chords due to erection stresses being temporarily taken up in the four middle panels of the lower chords which are of I bars. The raising of these spans was accomplished by 500 ton hydraulic jacks, two of which were used under each truss, one under each end of a short transverse jacking girder attached to the end of the lower chord.

The material tracks along the three central spans were erected as each panel was completed so that the members for the next panel could be run out on these tracks and reached by the traveler above. After the completion of the new trusses the old floor beams were cut away from the old trusses and blocked up on the new floor beams which had been erected below the lower chords in the same manner as in the end spans described above. The old trusses were then dismantled and removed, piece by piece, over the material tracks.

## ERECTION OF NEW APPROACH VIADUCT.

In connection with the replacing of the bridge, the 2,210 ft. of steel viaduct approach on the east side and a 300 ft. section of similar viaduct over two streets in the town of Kenova were rebuilt for double track. The old viaduct was built with inclined posts, special lugs being provided at the bottom of these posts to receive vertical columns in case it should be desired to double track the structure. The spacing of the pedestals under this viaduct was such that track girders carried on vertical posts would be at the proper distance from the track girders on the old structure to support the outer rails of a new double track.

For much the same reasons that it was decided to replace the bridge, it was also decided to build a new viaduct instead of taking advantage of this feature of the design of the old. The pedestals under the old viaduct were in very good condition, having been recently replaced on concrete piles. In order to utilize these pedestals, a design of viaduct in which the posts have a slight batter was adopted. Under the station platforms the posts are vertical and a third row of columns is provided. It was desired to reduce the grade of this viaduct approach from 0.5 to 0.3 per cent. by raising the east end of the viaduct about 5 ft., and the remainder of it by correspondingly lesser amounts, reaching the old grade line about over the second pier of the bridge.

This change in grade was made before the erection of the new viaduct was begun. A material track was first laid the full length of the trestle and timber blocking was distributed on which the old steel was blocked up to the new grade. The new steel was then distributed along the structure. The two spans

next to the bridge were first erected on falsework and the remainder were placed by a two boom traveler operating from the bridge outward on the new viaduct. The new bents were erected complete in the spaces between towers of the old viaduct alongside the old bents which they were to replace. The bracing in one tower of the old viaduct was then removed and temporary 6 in. x 12 in. timbers were placed from the bents of this tower to the adjacent bents of the towers on each side. The traveler then lifted the old girders clear of the old towers with the two booms. With an outhaul line on the ground the old bents were pulled over and the new ones pulled into place, the booms then dropping the girders on the new bents. It required from five to eight minutes to make the change in each bent, and it was possible to allow trains to pass between the placing of the two bents in each tower. The traveler was supported on girders erected over the posts of the new viaduct, sufficient clearance being allowed under the traveler to permit the free operation of trains on the two middle girders which remained in the same position as on the old viaduct.

On account of the change in grade at the Kenova station, which is located at the crossing of the Chesapeake & Ohio just west of the end of the approach viaduct, some alterations to the station were made necessary. A new baggage and express station was built and a new elevator installed for handling this traffic between the upper and the lower levels.

The reconstruction of this bridge was handled under the supervision of Charles S. Churchill, chief engineer, and C. C. Wentworth, principal assistant engineer. J. E. Crawford, acting chief engineer and formerly bridge engineer, was in charge of the design of the alterations to the substructure and the checking of the superstructure. F. P. Turner was the assistant engineer in charge of the work in the field. The methods used were worked up by the American Bridge Company under the direction of C. W. Bryan, chief engineer, and C. G. E. Larsson, assistant chief engineer, F. P. Witmer and Wm. G. Grove being the engineers on the design. The steel work was fabricated at the Ambridge plant. J. B. Gemberling was in charge of the erection, and H. Taylor was the engineer in the field.

## A CORRECTION.

Through a mistake the name of the author of the article entitled "Nomographic Method for Finding Center of Gravity and Moment of Inertia," which appeared in the issue of last week, page 381, was omitted. The author was M. J. Eichorn, Chicago, who is entitled to all credit for its preparation.

**SOUTH AFRICAN RAILWAY TROUBLE.**—Sir David Graaf, acting minister of railways, South African Union, notifies that the government will constitute a commission to inquire into a number of railwaymen's grievances, including the immediate introduction of the eight-hour day, a minimum wage for white employees from \$2 upwards per diem, the revision of local allowances, the abolition of piece work, the decentralization of management, and other grievances connected with pay.

**RAILWAYS AND THE STATE.**—The *Pall Mall Gazette* states that it has reason to believe that the preliminary steps in connection with one of the most important and far-reaching inquiries ever instituted in England has been taken on behalf of the government by the board of trade. During the past few years, in the House of Commons and elsewhere, appeals have been made to the government to endeavor by commission or committee to arrive at a more clear definition of the relations between the state and the railways of the country, both as regards directors and employees. The appeals for such an inquiry have not been confined to any particular section of the country, and railway directors and railway employees have shown no disposition to resent such action.



## UNCLE SAM'S FREIGHT CARS.\*

BY J. GARRETT HILL.

This is an argument in favor of government ownership of railway freight equipment—but not of the railways themselves.

There are those who believe that the time is ripe for our government to take over the railroads. And they also believe that great reductions in rates and fares would result, while at the same time the net revenue accruing to the government after deducting all operating expenses would soon have the coffers of our treasury overflowing.

I shall not stop to deny that government ownership of railroads may become practical within another generation or two. It certainly is not practical at the present time. And it is doubtful if any one living today will ever see the federal government successfully operating the railroads.

It is not my purpose, however, to argue that long step, but a much simpler one of real progress.

Government ownership of railway freight equipment is a very simple solution of our transportation problem. It is entirely practical, and could be put into effect with such ease that it would in no way disturb general business conditions. On the contrary, I believe that the country would enter upon an era of prosperity the like of which we have never known.

That there would be no serious opposition to this plan is evident, because:

It will benefit the shipper, the railroads, the government, and the public.

It will effectually prevent car shortages, and all shippers will be able to secure equipment promptly upon request.

It will prevent any possible chance of discrimination in furnishing equipment.

It will at once put the government in close touch with the movement of all freight traffic.

It will at once give the railroads all the capital they require for increased terminal facilities, additional motive power, and general improvements.

It will not affect the present railroad officers and employees.

It will not materially change the present method of operation.

It will not change the present existing freight rates.

It will not affect present earnings and dividends—except to increase them.

It will not affect the Interstate Commerce Commission.

It will not affect the present ownership of railroad tracks, locomotives, or anything else connected with railroads other than freight equipment.

At the present time there are in use approximately 2,500,000 freight cars which should be purchased by the government at an average price not to exceed \$800 per car. This would result in an investment of \$2,000,000,000; and to this should be added approximately \$1,000,000,000 for storage yards, making the total cost to the government approximately \$3,000,000,000.

The storage yards should, of course, be located at various points throughout the United States and accessible to all railroads, so that cars could be furnished to any line promptly upon request and returned to the government yards by the railroads when not in use.

The charge to be made by the government for the use of equipment is, of course, a matter of detail to be worked out. But I personally consider fifty cents per car per day, plus one cent per car per mile, a fair charge. (At the present time the railroads have in effect a *per diem* rule whereby they pay forty-five cents per car per day for all foreign cars on their line; and they pay owners of private car lines three-fourths of a cent or more per mile for the use of their cars.)

The charge of fifty cents per car per day would be sufficient to insure the prompt handling of all cars by the railroads; for the transportation department of the various lines would be anxious to get the cars off their rails at the earliest possible moment in order to be relieved of this charge.

The average movement of a freight car (including periods of idleness) is about twenty-four miles per day; based upon this, and assessing charges as mentioned above, the earnings of the government would be as follows:

<i>Daily Earnings.</i>	
2,500,000 cars at 50 cents per car per day.....	\$1,250,000.00
2,500,000 cars at 1 cent per mile per car, av. 24 miles per day.....	600,000.00
Total daily gross earnings.....	\$1,850,000.00
<i>Annual Gross Earnings.</i>	
2,500,000 cars figured on above basis.....	\$675,250,000.00
EXPENSES UNDER GOVERNMENT OWNERSHIP.	
<i>Initial Expense.</i>	
2,500,000 cars at \$800 each.....	\$2,000,000,000.00
Cost of storage yards (estimated).....	1,000,000,000.00
Total initial cost.....	\$3,000,000,000.00
<i>Annual Expenses.</i>	
\$3,000,000,000.00 at 4 per cent interest per annum.....	\$120,000,000.00
Cost of upkeep and operation, including salaries, etc.....	80,000,000.00
Total annual expense.....	\$200,000,000.00

From this you will note the annual gross earnings are \$675,250,000, while the total operating expenses, including interest on original investment, are only \$200,000,000. Thus the net revenue accruing to the government, after deducting all expenses, reaches the stupendous total of \$475,000,000 per year.

This would at first appear to be an excessive charge, and you might infer that the present earnings of the railroads would be greatly reduced. Such is not the case, as the earnings would be considerably greater than at the present time: for sufficient equipment could be had at all times by the railroads, whereas under the present system the loss to the lines each year through lack of equipment is enormous.

This loss to the railroads also means a great loss to the shippers and consumers: The shipper loses the sale of his goods or, should the goods be perishable, loses the goods themselves; while the consumer's loss is measured by the difference in the price he is obliged to pay on account of the demand for the article he desires being greater than the supply, and this condition, when traced back, is found to be due to the fact that the railroads were unable to furnish equipment to bring the goods to market.

In addition to this the railroads and the public suffer a great loss every year on account of insufficient terminal facilities. This is due in large measure to the lack of sufficient funds; and many are the companies who are today endeavoring to increase their capital stock, or issue bonds and notes, to invest in improved terminal facilities.

Government purchase of freight equipment would at once give the railroads ample capital not only to increase their terminals, but also to meet all demands in the way of improvements for years to come—besides leaving a large surplus in their treasury.

As a concrete example of what this would mean to the railroads, take, for instance, the Pennsylvania, east and west, which has in use at the present time 246,665 freight cars. These cars, purchased at \$800 each, would give the Pennsylvania a total of \$197,332,000, or \$23,812 per mile for their freight equipment, all or any part of which they could invest in improved terminals and other betterments.

Or take one of the smaller lines, such as the Buffalo, Rochester & Pittsburgh. It now has in use 17,741 freight cars, for which it would receive from the government \$14,192,800, or approximately \$24,000 per mile of road.

This change would enhance the value of railroad securities, as the earning power would be greater for reasons above explained, and with increased earnings come increased dividends—which in turn result in higher values of securities.

Further, this would enable the railroads to progress at once beyond a point that under present conditions will take them fifty years to reach. And the American people would enjoy a railroad service the efficiency of which could not be improved upon. At the same time the net income to the government would exceed one million dollars per day, while the railroads would be operating under less expense than at the present time.

\*Reprinted by kind permission from *Everybody's Magazine* for September.

# AIR BRAKES AND MODERN CONDITIONS.\*

A Study of the Effects of Changes in Railway Operation  
and Heavy Passenger Train Cars on This Equipment.

BY WALTER V. TURNER AND P. H. DONOVAN,  
Of the Westinghouse Air Brake Co.

I doubt if, outside of the locomotive, there is anything that can make more money for the railroad in certain sections of the country, and particularly in congested districts, than the brake. On the other hand, no matter where the brake is used, whether in congested districts or not, there is nothing that can lose more money or cost more than the brake, if the proper brakes are not used in the first place and not properly cared for in the second place. The reason will be apparent when the tremendous energy that has to be dissipated in stopping or controlling a train of today is considered.

The money making power of the brake is well illustrated in the case of the New York subways. In 1910 it was desired to increase the train capacity. They were considering putting on larger motors in order to get a speed of 60 m. p. h. instead of 40, and therefore get over the road in shorter time. That looks perfectly natural, and yet as a matter of fact under those conditions they would have actually consumed more time between stations than with conditions as they were, for when the speed of a train is doubled it takes four times the distance to stop, and in this case it would require more than twice the distance to stop. Then it was suggested that better brakes be used and stop sooner or in shorter distances. The time saved by deceleration has a value equal to that saved by acceleration and a much more rapid rate of deceleration was obtainable, thereby increasing the capacity. This more rapid rate of deceleration was obtainable by making a greater use of the potentiality of the rail. It may not have occurred to many people, but the rail is the starting point for the brake. The basis of the whole matter lies with the rail, and it is only by measuring the rail capacity that the possibilities of stopping can be determined.

With the better brakes the time of stopping was cut down to one-half of that previously required and the emergency stop was cut from 650 to 350 ft., so that the signal space could be shortened, and together the capacity of the subway was increased about 40 per cent. per day. This shows what can be done with the brake. It cost some money to do this, but not one-twentieth of what it would have cost to have obtained the same result by other means.

With such tremendous energy as we have today to cope with, braking is an important problem, particularly when the time element is considered, which is the most important element in the air brake. There are many, even among railroad men, who fail to take this into consideration. The engineer on the engine looks at his gage and thinks that what takes place on the head end takes place at the rear end at or about the same time, while, as a matter of fact, the brakes may be full set on the head end before they have commenced to apply at the rear, and on long freight trains even before the twentieth brake has commenced to apply.

While we find railroad men in all other departments of railroad activities writing and discussing upon the various interlocking and interdependent physical equipments and scientific development of the organization, I cannot call to mind any railroad man who has discoursed very much upon the subject of brakes, and from this I am led to conclude that either they do not realize the tremendous importance of this wonderful safety device, or that it is the important dividend earning asset, or, that the subject is too complex and involved for them to take the time to

know it as thoroughly as they do other phases of their duties, or apparatus that goes to make up the physical equipment of a railroad, or that they are willing to leave all consideration of the brake equipment and train control to the air brake man, or air brake engineer, as I hope some day to hear him called, of the road.

To the end then of a better understanding of why the changed conditions and rolling stock affect the efficiency of the air brake, I beg to call attention to the following factors:

#### *The Element of Time*

- (a) Service Operations.
- (b) Emergency Operations.

#### *Flexibility—The Importance of*

- (a) Factors of.
- (b) Time.
- (c) Auxiliary Reservoir.
- (d) Piston Travel.
- (e) Braking Force.

#### *Foundation Brake Gear.*

- (a) Single shoe gear.
- (b) Double shoe gear.

#### *Brake Shoes.*

- (a) Some of the characteristics of.  
*All of the above apply, to a more or less degree, to passenger and freight car brakes.*

#### *High Pressure Brakes for Passenger Cars.*

- (a) Velocity.
- (b) Mass.
- (c) Acceleration.
- (d) Retardation (Rail) for often it is the rail that determines the minimum stop possible is, in fact, the starting point of the brake.

#### *Empty and Load Brake for Freight Cars.*

- (a) Empty weight of car and its braking force. (Whenever the term braking power is used it should be understood as synonymous with braking force.)
- (b) Loaded weight of car and its braking force.
- (c) Level track—necessity for uniform braking force on.
- (d) "Grades"—necessity for sufficient braking force.

#### *Hand Brakes.*

- (a) Empty cars.
- (b) Loaded cars.
- (c) Effect of high capacity cars on the hand brakes.

#### *Locomotive Brake Appliances.*

- (a) Compressor.
- (b) Main, or Storage Reservoir.
- (c) Governor.
- (d) Engineer's valve used for manual operation of the brakes.
- (e) Brake Apparatus.

#### *Electrical Attachments for the Operation of Pneumatic Brakes.*

- (a) Energy.
- (b) Acceleration.
- (c) Retardation.
- (d) Grade.
- (e) Concussion.

So much for the brakes considered individually. Then they must be considered collectively, for the operation, and perhaps all of the preceding considerations, may be greatly changed and, in fact, are changed by the combination in the many different ways and under the multitudinous conditions possible; therefore, we have to consider, in this engineering problem, the length of the train; the weight of the train; greater frequency of trains, and the effect of these things on the efficiency of the apparatus due to the larger volume of air to be handled and the time element necessarily involved; the shocks produced by the enormous energy necessarily inherent in long and heavy trains under move-

\*Abstracted from the April 25, 1913, Proceedings of the Railway Club of Pittsburgh.

ment; the air supply required, which, obviously, is greater with every vehicle added to a train; the larger apparatus required for the heavier cars; the effect of the lapse of time between the application of the brakes on the head end and the rear end of the train; the difference in time between the releasing of the brakes on the front and rear end of the train, and last, but not least, the possibility of the personal equation being equal to the many degrees of manipulation required and its ability to properly judge the right thing to do for each condition or occasion.

Then come the problems of installation, maintenance, and the information to be given the men of the different departments under which come the apparatus, and, of course, the instructions, general and particular, to all concerned.

The work required in stopping a train consisting of 2 locomotives weighing 194 tons each and 10 passenger cars weighing 75 tons each from a speed of 80 m. p. h. is better appreciated when it is considered the same amount of work would be performed by lifting a weight of 1 ton over 48 miles in the air, or the energy dissipated in stopping this train would run one of the large steel street cars in Pittsburgh for a distance of 66 miles, or if this retarding force were applied to a projectile as it left the mouth of a 14 in. gun it would travel but 1,050 ft., as compared with an actual travel of 25 miles.

The foregoing illustrations clearly show the conditions as far as magnitude is concerned, and as the controlling of such enormous masses when in motion is certainly as important as to give motion itself, it is obvious that the controlling mechanism is of vital importance, if not in the last analysis entirely the determining factor, as to whether or not such development is permissible.

#### PASSENGER SERVICE CONDITIONS.

Considering for the moment passenger equipment only, natural improvement, combined with the effort of railroad companies to attract business by superior equipment, and the demand of the traveling public for greater comfort when traveling, shorter schedules (higher speeds), and at the same time greater safety, has led to the development of heavier rolling stock. These cars and locomotives are of such weight that they cannot be as efficiently braked with the older type of air brake equipment as could the rolling stock of years gone by.

The following example will show what the increase in the weight alone means to the operating department if it is to accomplish a presumably desirable result. Under former conditions, the factor of safety in train handling was none too great, and it is, therefore, imperative that we should be able to control modern trains under present existing conditions, at least as safely and effectively as formerly.

To do this for twelve 150,000 lb. passenger cars running at 60 m. p. h., it is necessary to provide means for controlling over 200,000,000 ft.-lbs. of energy as compared with 6,000,000 ft.-lbs., which was what the brakes of 30 years ago were called upon to control, with a train of five 30,000 lb. cars running at 35 m. p. h. When the locomotive used with each train (one for the early and two for the modern conditions) is considered, the total energy in the modern train becomes 373,086,394 ft.-lbs., as compared with 9,800,000 ft.-lbs. for the trains of 30 years ago.

It is not surprising, therefore, that the air brake art demands thoughtful consideration from trained and experienced minds if the railroad traffic of today is to be handled with a safety and efficiency equal to that of the days when the total energy to be reckoned with was one thirty-eighth as great.

Contrasting the modern Pullman car weighing 150,000 lbs., and having six-wheel trucks, with the earlier passenger car having four-wheel trucks, and assuming that from a speed of 60 m. p. h., the stop should be made in 20 seconds, the work done would be 37.5 foot-tons per brake shoe per second, or over three times that of the earlier train, notwithstanding that there are twelve brake shoes to do the work instead of eight. The use of two brake shoes per wheel is rapidly becoming a

necessity, not only on account of the great amount of work to be performed by each brake shoe, but also because the brake shoe pressure required by modern conditions, high speeds, and heavier cars, becomes so enormous that in emergency applications too great pressure is brought to bear on the pedestal and journals by the brake shoes acting on one side of the wheels.

The tremendous significance of this increase is but faintly appreciated by those who have not had occasion to investigate this aspect of the question. The cast iron brake shoe is today practically as it was thirty years ago. This brake shoe must now do four times the amount of work by frictional resistance to the rotation of the wheel, as formerly. It may be suggested, "Why not quadruple the pressure per brake shoe?" But it also must be remembered that when the brake shoe pressure is multiplied by four, the actual retarding force is by no means quadrupled, for three vital adverse factors are being overlooked, viz., the effect of increased pressure, speed and time on the coefficient of friction (because of heat) between the wheel and the shoe. Also, that the brake shoe wear increases very rapidly with extremely high temperatures, and if for no other reason, it would warrant the expense of a two shoe per wheel installation for the saving in brake shoe wear and maintenance for the modern passenger train condition.

#### IMPROVED PASSENGER BRAKE EQUIPMENT.

While the fundamental service and emergency features of the quick action brake could not be departed from on account of the necessity for maintaining interchangeability of apparatus and operative functions, it was clear that in designing a brake to meet these new conditions not only must the fundamental features of the old brake be improved to their highest possible efficiency, but new features must be added, some of which were inherently impossible if the design were carried along the lines previously laid down.

Briefly stated, the recognition of the higher efficiency and added means required by the changed conditions referred to led, in case of the passenger brake, to the incorporation of the following features in addition to those characteristic of the previous form of equipment.

1. Quick rise of brake cylinder pressure so that the braking force may reach its maximum in the shortest possible time and thus begin to be effective in reducing the speed when at its highest value—and when the increase in distance run before coming to a stop is greatest for every second's delay.

2. Uniform braking force on all cars, irrespective of size of equipment and variation in piston travel, thus contributing largely to the convenience and comfort of passengers, as well as making the brake more reliable and therefore easier to manipulate.

3. Maintenance of both service and emergency brake cylinder pressures up to the capacity of the ample storage reservoirs of the cars. This is of the greatest advantage in overcoming the ever-present and often serious depletion of brake cylinder pressure by packing leather leakage.

4. Predetermined and fixed limiting of maximum service braking force, without a safety valve or other blow-off device. This maintains the proper margin between the force of service and emergency applications and tends to reduce wheel sliding without wasting air and with a minimum of apparatus, thus resulting in economy both of operation and maintenance.

5. Quick service feature to compensate for increased length of train and bring about more prompt, uniform and certain application of brakes.

6. Quick recharge of the auxiliary reservoirs to offset longer trains and larger cylinders and reservoirs and insure a prompt application of the brakes when desired and prevent the depletion of the auxiliary reservoir pressure.

7. Graduated release feature to add to the flexibility of the brake by making it possible to graduate the brakes off as well as on and so to handle the train more smoothly, with a greater

saving of time, and a reduction in the amount of wheel sliding.

8. Much higher brake cylinder pressure obtained in emergency for the same brake pipe pressure carried, which pressure is maintained and retained during the complete stop, thus materially shortening the stops and adding greatly to the safety of the trains.

9. Automatic emergency application on depletion of brake pipe pressure. This is a safety and protective feature of great value, in that it insures sufficient braking force being automatically obtained to bring the train to a stop in case the system is depleted below a predetermined pressure either by careless manipulation or accidentally.

10. Full emergency braking force at any time, thus placing the maximum stopping power the brake has to offer at all times ready for use by the engineer whenever an emergency arises, irrespective of what may have preceded.

11. Separation of service and emergency features so that the necessary flexibility for service application can be obtained without impairing in the slightest the emergency features of the equipment and conversely, so that undesired quick action is practically impossible.

12. High maximum braking force secured with low total leverage, with correspondingly greater over-all efficiency of the brake.

Controlling means for passenger cars should not be dismissed without a reference to operating the mechanism by electricity. Actuating the brakes electrically results merely in the elimination of the time element of application, the retarding force coming solely from the pneumatic operation. The heavier vehicles and lengthened trains have vastly increased the energy to be controlled and magnified the time element necessarily involved in so doing it. With this end in view, great improvements have been made in the purely pneumatic brake, but full attainment is only possible when the pneumatic brake is operated electrically, as by this means the time element between the first and rear of the train is reduced, and the degree of retardation best suited to speed can be measured to a degree.

It is seldom that any one device or appliance offers the solution of so many problems, overcomes so many difficulties and at the same time utilizes such a vast energy that now is dangerous or goes to waste.

This system eliminates time as far as brake initiation and propagation is concerned.

It eliminates retardation shocks since it reduces brake operation as closely to the effects as though one vehicle only was being retarded.

It reduces the human equation to a very low factor, as it is so promptly responsive and flexible that correction of errors of judgment in manipulation can be made before inconvenience can occur.

It is free from many of the shortcomings of other brake equipments, special care being taken to insure its immunity from influences (which unavoidably exist) that cause brake operations contrary to what are contemplated or when not desired.

It increases the safety of train operation because full emergency braking force is available and obtainable always and is instantaneously effective.

For "service" (station stops, etc.) operation, it is especially valuable from a revenue standpoint, as it permits of stops being made in much less time with a reliability, smoothness and accuracy heretofore impossible.

It permits of accurate, instant and comprehensive communication between the engineer and train crew, or vice versa, thus contributing largely to co-operation and efficiency.

It is reliable, adaptable and complete.

What this progress in passenger brake development represents in increased economy of train operation depends upon the view point, that is to say, if cost of change is to be the determining consideration then the improvement possesses no value

to the one who so considers; if, however, he desires to secure the economy and increased efficiency arising from such development, it can be obtained in various ways. As, for example, if the power consumed be kept the same with the shorter stop economy along the following lines is implied: (1) Higher average speeds, (2) shorter schedules, (3) for the same number of cars increased traffic capacity, (4) for fewer cars the same traffic capacity. If it is desired to secure economy by a reduction in power consumption, this can be accomplished, still retaining (1) the same average speeds and (2) the same schedules and capacity.

Assuming the stop to be reduced from 40 seconds to 20 seconds, it is obvious that it is possible to run with power on for 20 seconds where before the train was run with brakes on for this same 20 seconds. If the train does not accelerate while this power is on, a saving in running time between stops of 10 seconds is made. (If the train accelerates, a greater saving is made.) Assuming the trip to be two hours long when making 40-second stops and 100 stops to be made, reducing the time of stop to 20 seconds results in reducing the time of the trip to 1.44 hours. That is, while the old train was making one trip, the new train would make 1.39 trips. Or if both trains consisted of 5 cars, in one day these 5 cars with the new train would have a value of 62 cars as compared with a value of 45 cars with the old train, and assuming 60 passengers per car the new train would be capable of carrying 3,720 people per day as compared with 2,700 people per day with the old train, or an increase of 38 per cent. From this example it will be seen that under conditions of congested traffic, a brake of maximum efficient design will add as much to the carrying capacity of the road as would the purchase of numerous vehicles (2 for the example taken), which, however, it would not be possible to operate because the old brakes do not permit of the required headway, etc.

As to emergency applications, we assume the stop to be reduced one-half. It is obvious that the same margin of safety could be obtained with the headway cut in two making it possible to run twice as many trains as is possible with the longer stop and still retain the same safety factor.

From another view point, as we have seen, economy may be secured by reduced power consumption. The following calculations are submitted to indicate what this economy may be under the conditions as assumed.

In suburban passenger train service train movement consists essentially of a period of acceleration and a period of deceleration, time between stops being the sum of these two. *If time between stops remain constant and the period of deceleration be shortened by the use of improved brake equipment, it is possible to introduce a period of coasting.* A period of coasting implies a lower maximum speed which permits of a shorter accelerating period or allows steam (current) to be cut off sooner. It is evident that a *reduced steam (current) consumption* gives a *reduced coal consumption*. The following calculations indicate what the reduction might be.

CONDITIONS.

- Average distance between stops, 1.3 miles.
- Average speed between stops, 24 m. p. h.
- Average time stop with old equipment, 50 seconds.
- Average time stop with improved equipment, 25 seconds.
- Weight engine and tender, 136,000 lbs.
- Number cars in train, 8.
- Weight per car, 80,000 lbs.
- Train resistance during acceleration, 10 lbs. per ton.
- 3.5 lbs. coal per i. h. p. hour.
- Efficiency from cylinders to crank pins, 85 per cent.
- Number accelerating periods per run, 12.
- Actual length run, 17 miles.
- Total runs per day, 75.
- Cost of coal, \$2.50 per ton.
- Trains operated 18 hours a day.

COAL USED WITH OLD EQUIPMENT.

- 1.3 miles ÷ 24 m. p. h. = 195 seconds between stops.
- 195 - 50 = 145 seconds time train accelerates.

$$\frac{\text{Maximum Velocity}}{2} \times 145 + \frac{\text{Maximum Velocity}}{2} \times 50 = 1.3 \times 5,280.$$

Maximum Velocity = 70.5 ft. per sec. = 48.0 m. p. h.  
Maximum Velocity is attained in 145 seconds.

Acceleration = 48.0 ÷ 145 = .33 m. p. h. per sec.

Weight train = 136,000 + (8 × 80,000) = 776,000 lbs.

$$\text{Accelerating force} = \frac{776,000}{32.2} \times \frac{.33 \times 5,280}{3,600} = 11,700 \text{ lbs.}$$

Force necessary to overcome train resistance, accelerate moving parts, etc. =

$$\frac{766,000}{2,000} \times 10 = 3,830 \text{ lbs.}$$

Total force to move train at rate indicated =

$$11,700 + 3,830 = 15,530 \text{ lbs.}$$

Horse power at average speed of 24 m. p. h. =

$$\frac{15,530 \times 24 \times 1.47}{550} = 1,000 \text{ h. p.}$$

I. h. p. at 85 per cent. efficiency = 1,000 ÷ .85 = 1,180 i. h. p.

Coal consumption = 1,180 × 3.5 = 4,120 lbs. per i. h. p. hr.

$$\text{Coal consumption per acceleration} = 4,120 \times \frac{145}{3,600} = 166 \text{ lbs.}$$

Coal consumption per run = 166 × 12 = 1,999 lbs.

Coal consumption per year = 1,999 × 75 × 313 ÷ 2,000 = 23,400 tons.

**COAL USED WITH IMPROVED EQUIPMENT.**

195 seconds between stops as with old equipment.

195 — 25 = 170 seconds time of combined acceleration and coasting.

Maximum velocity = m. p. h. per sec. times time of acceleration.

Assume m. p. h. per sec. same as with old equipment = .33 m. p. h. per sec.

$$\frac{\text{Max. Velocity}}{2} \times \text{time of acceleration} + \text{av. velocity coasting} \times \text{time of coasting} + \text{av. velocity deceleration} \times \text{time of deceleration} = 1.3 \times 5,280.$$

From above, time of acceleration = 126 seconds.

$$\text{Coal consumption per acceleration} = 4,120 \times \frac{126}{3,600} = 144 \text{ lbs.}$$

Coal consumption per run = 144 × 12 = 1,730 lbs.

Coal consumption per year = 1,730 × 75 × 313 ÷ 2,000 = 20,300 tons.

**SAVING IN COAL.**

Tons per year old equipment..... 23,400

Tons per year improved equipment..... 20,300

Saving ..... 3,100 tons.

3,100 tons at \$2.50 per ton = \$7,750.

**RETURN REALIZED ON INVESTMENT.**

18 hours ÷ 75 trains = .24 hours between trains average.

17 miles ÷ 24 m. p. h. = .708 hrs. per trip one way.

.708 × 2 ÷ .24 = 5.9 = 6 trains.

Allow two trains for uneven spacing.

Total trains = 8.

Cars per train = 8.

Total cars required for service = 64.

Assume old equipment to be returned and improved equipment to be put on at \$200.00 per car.

Cost improved equipment = 64 × 200 = \$12,800.

Return on investment = 7,750 ÷ 12,800 = 60.5 per cent. per year.

While these calculations assume certain conditions of operation, it must not be thought they are in any manner exceptional, for there is no operation but what can be improved in earning capacity to a greater or less degree by taking advantage of modern brake apparatus.

**NEW LINE FOR INDIA.**—A concession has been granted for constructing a light, feeder railway, 2 ft. 6 in. gage, from Jacobabad, on the Northwestern State Railway, to the town of Kushmore, about 77 miles distant. It is estimated that owing to the flat nature of the country through which the line will pass, and the total absence of any expensive bridgework, the line can be constructed at the low cost of \$5,353 per mile, excluding rolling stock, but including junction arrangements, shipping platforms, locomotive and car shops at Jacobabad. Rolling stock will be provided by the company according to the requirements of traffic; but it is not proposed to expend more than about \$2,800 a mile on rolling stock at first. By keeping capital cost at these low figures, it is anticipated that shareholders will receive a good return soon after the line is opened, with fair prospects of still larger returns as the country is further developed.

**PRINCIPLES OF ELECTRIC RAILROADING.\***

By C. L. DE MURALT,

Professor of Electrical Engineering, University of Michigan.

IV.

In looking into any railway electrification problem the first step to take is to calculate the force which is required to move the trains.

In the last article of this series (*Railway Age Gazette*, August 8, 1913) it was shown how this force, generally called "tractive effort," can be computed if the train weight is known, and the various other factors which influence the train movement, such as average weight per car, train speed, etc. The following formula was found for this purpose:

$$f = W \left( 2 + 0.1 V + \frac{90}{W'} + 100A + 20 p \right) \quad (4)$$

where *f* is the tractive effort in pounds, if *W* is the weight of train in tons, *V* the speed in miles per hour, *W'* the average weight per car in tons, *A* the rate of acceleration in miles per hour per second, and *p* the grade in per cent. including effect of curvature.

The second step is the determination of the weight which must be placed on the drivers of the locomotive in order to make it possible for the engine to produce the required tractive effort.

In this connection it was shown that there is a very simple and direct relation between tractive effort and required weight on drivers.

This relation can be expressed by the formula:

$$W'' = \frac{f}{0.22} \quad (6)$$

where *W''* is the weight on the drivers in pounds, if *f* is the tractive effort in pounds. In other words: To produce a certain number of pounds of tractive effort, we must place at least four and one-half times as many pounds on the drivers.

In the majority of cases the required weight can be placed on the drivers of a single locomotive, but it was found that there are at least two sets of conditions which may make this difficult. The first set presents itself in all cases where extremely high rates of acceleration are desirable, for instance, in high speed, frequent stop, passenger service. The second set is found where a railroad has very steep grades. In either case the tractive efforts may be so high that the corresponding weight cannot readily be placed on the drivers of a single rigid wheel base. In that event, the use of multiple unit locomotives or of motor car trains becomes essential.

The third step in the calculation of the horse power output which the engine or motors must be capable of giving in order to develop the tractive effort at the desired speed.

**HORSE POWER.**

The introduction of the term horse power is necessary, because it is conceivable that a locomotive may be heavy enough to give the required tractive effort and yet not possess power enough to actually exert that effort and move the train.

There are really two limits to the work which a locomotive can do:

First, there is a limit to its tractive force. This depends on the weight placed on drivers.

Second, there is a limit to its speed. This depends on the size and output of the steam engine or electric motor, as the case may be.

To obtain the best results, weight on drivers and motor output must be properly balanced. The locomotive must be heavy enough so as not to slip its wheels when the desired tractive effort is developed, and the engines or motors must be of sufficient capacity so as to actually be capable of giving this tractive effort at the desired speed.

A locomotive is called under-powered if its motors cannot do

\*Copyright, 1913, by the Simmons-Boardman Publishing Company.

this. It is called over-powered if it does not have sufficient weight on drivers to allow its motors to develop their full output. The usual practice is to make a locomotive slightly over-powered, rather than under-powered.

In the case of the steam engine this is taken care of by dimensioning the steam cylinders so that

$$f = \frac{p d^2 s}{D}$$

where  $f$  stands for the maximum desired tractive effort in pounds,  $p$  for the mean effective steam pressure in pounds per square inch (which is generally taken as being equal to about 85 per cent. of boiler pressure),  $d$  for the cylinder diameter in inches,  $s$  for the length of stroke in inches, and  $D$  for the diameter of the driving wheels in inches.

This formula is based on the fact that the work performed by one piston in a single stroke is equal to

$$p \frac{\pi d^2}{4} \times s$$

If the engine is a simple two cylinder machine, there are four strokes per revolution. Therefore the work performed by the engine as a whole during one revolution is equal to

$$p \pi d^2 \times s$$

During one revolution the engine will traverse a distance of  $\pi D$  inches, and, inasmuch as equal amounts of work are performed when products of force times distance are equal, we have:

$$f \times \pi D = p \pi d^2 \times s$$

and therefore:

$$f = \frac{p d^2 s}{D} \text{ as above.}$$

A steam engine dimensioned in this manner will have an output:

$$O = \frac{p \times \pi d^2 \times s}{12 \times n} \times \frac{1}{33,000} \text{ horse power.}$$

Similar means are used to determine the dimensions of steam cylinders in the case of compound engines, but it is not necessary to go into the matter at this point. Suffice it to say that the engine part in a well designed steam locomotive is always made sufficiently powerful so that there is no question about its being able to develop the required tractive effort.

It is necessary to arrange likewise in the case of an electric locomotive.

Steam engines have their output directly proportionate to steam pressure, cylinder volume and number of revolutions per minute. The output of electric motors is determined by the dimensions and the arrangement of the copper conductors which are used in their winding. This is a rather intricate point of design and it is beyond the grasp of most of us. Luckily, however, it is not necessary to be an electric motor designer in order to determine whether a certain motor is powerful enough for the service or not. It is largely a question of its being able to get rid of the heat which is produced by the electric current as it passes through the motor windings.

Electric motors are customarily sold on the basis of being able to develop a certain number of horse power without heating beyond a certain temperature, say 75 degs. C., which has been found in long practice to be sufficiently low so that no part of the motor will suffer any injury.

It thus comes down to the point of determining the number of horse power which are required to move the train.

The term horse power as a measure of machinery output was introduced by Thomas Savery, the inventor of an earlier type of steam engine. James Watt adopted the term for expressing the power of his machines and he established its present day value by means of experiments which were made under the direction of himself and of Boulton, his business partner, about the year 1775.

Some heavy London brewery horses were caused to raise a weight from the bottom of a deep well by pulling horizontally on a rope passing over a pulley. It was found that a horse

could raise a weight of 100 pounds while walking at the rate of 2.5 miles per hour or 220 feet per minute. This is equivalent to 22,000 foot-pounds per minute. Watt added 50 per cent. to this value so that the purchasers of his engines might have no ground for complaint, and thus established a value of one horse power = 33,000 foot-pounds per minute, which has since been in general use in England and the United States.

If the output of a horse is called one horse power when it exerts a force of 150 pounds while traveling at a speed of 2.5 miles per hour or 220 feet per minute, then our problem is to establish what will be the horse power output of a locomotive when it exerts a force of  $f$  pounds while traveling at the speed of  $V$  miles per hour or  $v$  feet per minute.

If we designate the horse power output of the locomotive by  $O$ , then we have:

$$O = \frac{f \times v}{33,000} = \frac{f \times V \times 5,280}{33,000 \times 60}$$

$$\text{or; } O = \frac{f \times V}{375} \text{ horse power} \tag{7}$$

where  $f$  is the tractive effort in pounds and  $V$  the speed in miles per hour.

This value  $O$  gives us the output for which the engine or motor of the locomotive must be designed.

RELATION OF HORSE POWER TO WATT.

In modern calculations the term watt is frequently used in place of horse power as a measure of machinery output. For this reason it may be well to point out the relation which exists between the two terms.

The watt is a unit in the so-called "C. G. S." (Centimetre, Gramme, Second) or "absolute" system of physical measurements. One watt is defined as being equal to ten million dyne-centimetres per second.

The dyne is the unit of force and is defined as that force which, acting during one second on a mass of one gramme, will give it a velocity of one centimetre per second. One gramme equals 0.0022046 pounds. One centimetre equals 0.3937 inches. The weight of the gramme varies from place to place. At 50 degrees latitude and sea level, or approximately under the conditions under which Watt made his historical experiments to determine the horse power, we have:

$$1 \text{ dyne} = \frac{1}{981} \text{ grammes} = \frac{0.0022046}{981} \text{ pounds}$$

$$1 \text{ dyne-centimetre} = 0.0000007373 \text{ foot-pounds}$$

$$\text{and: } 1 \text{ watt} = 10,000,000 \text{ dyne-centimetres per second} = 0.7373 \text{ foot-pounds per second}$$

Further up it had been established that:

$$1 \text{ horse power} = 550 \text{ foot-pounds per second}$$

Therefore we have the relation:

$$1 \text{ horse power} = \frac{550}{0.7373} = 746 \text{ watts}$$

$$\text{or: } 1 \text{ watt} = \frac{1}{746} = 0.00134 \text{ horse power}$$

This is the relation which has been recognized by English and American engineering societies and by the U. S. Bureau of Standards. In other countries the equivalents are only approximate, due principally to the difference in the value of gravity, but the discrepancy is not very great.

The watt is an interesting unit from the electrician's viewpoint, because

$$1 \text{ watt} = 1 \text{ volt} \times 1 \text{ ampere.}$$

Thus the electrician can more readily change mechanical values into electrical values if he uses the watt instead of the horse power. This explains why the term watt is more appreciated by electrical than by mechanical engineers, even though Watt himself was a mechanical and not an electrical man.

It will be noticed that the watt is a pretty small unit compared with the horse power. For sake of convenience it is therefore often best to use a multiple of the watt, namely, the kilowatt.

$$1 \text{ kilowatt} = 1,000 \text{ watts} = 1.34 \text{ horse power.} \tag{8}$$

## A RECORD SHIPMENT BY PARCEL POST.

A recent Associated Press despatch carried the news that a record shipment by parcel post had been made from Farmington to Gallup, N. M. This shipment affords a striking illustration of the results that may arise from the recent order of the postmaster general increasing the parcel post weight limit within the first and second zones from 11 to 20 lbs.

The first and second parcel post zones include all territory within any quadrangle representing an area having a mean radial distance of approximately 150 miles from the center of the quadrangle. Under the order of the postmaster general, which was issued on July 25, and went into effect on August 15, the rate on a 20 lb. shipment within the first and second zones is 24 cents. It will be noted that this rate does not apply for moving goods a maximum distance of 150 miles, but for moving them between points not more than 150 miles apart geographically, or "as the crow flies." Farmington and Gallup, being less than 150 miles apart, lie within the first and second zones. Evidently J. G. Hastings of Farmington had taken pains to inform himself regarding all these facts, for on August 16, the day after the order of the postmaster general went into effect, he delivered at the postoffice at Farmington for transportation to himself at Gallup a shipment of 240 20-lb. boxes of fresh fruit. There is no direct railway line between Farmington and Gallup. Therefore, under the requirements of the Postoffice Department this shipment of 4,800 lbs. was carried by parcel post by the Denver & Rio Grande 359 miles to El Moro, Colo., where it was transferred to the Santa Fe. The latter road carried it 429 miles further to Gallup, where, under the Postoffice Department regulations, it was required to deliver the fruit from its station to the postoffice. The transfer of the shipment at El Moro caused a delay of twelve minutes to one of the Santa Fe's best passenger trains, No. 9, and its unloading at Gallup caused another delay of ten minutes, a total delay to the train, involving inconvenience to the passengers as well as expense to the railway, of 22 minutes. At Gallup, in order to make delivery of this same shipment to the postoffice, it was necessary for the Santa Fe to use two extra trucks and four men—two of them for 45 minutes and the other two for 30 minutes each. On the following day the same shipper consigned 80 boxes, or 1,600 lbs. of fruit from the same origin to the same destination, which was, therefore, handled by the same railways in the same way.

The two shipments amounted to 6,400 lbs., or over three tons. The regulations of the Postoffice department evidently are predicated on the theory that 24 cents is a reasonable rate to be charged by the department for transporting 20 lbs. of goods a maximum of 150 miles. Because of the circuitous route by which these shipments were made the department received an average of only 4.5 cents for moving each 20 lbs. each 150 miles of the distance.

However, the department fared better than did the railways, which really rendered the service. The department got a total of \$76.80 for handling the two shipments. The railways, which carried these more than three tons of perishable goods almost 800 miles, received practically nothing for the service rendered by them. The law provides that the postmaster general shall readjust the compensation to be paid to the railways for carrying the mails on weights taken for not less than 90 days at least once in four years. The postmaster generals have adopted the policy of weighing the mails only once in four years, and basing the compensation of the railways for all the succeeding four years on this quadrennial weighing. When Congress passed the parcel post law everybody foresaw that it would cause a large amount of shipments to be diverted from the express and freight cars to the mail cars, but the only provision Congress ever has made for paying the railways for handling the traffic thus transferred to the mails, is that their total compensation for carrying the mails might be increased on July 1,

1913, a maximum of 5 per cent. As the parcel post traffic has increased the mail service rendered by the railways much more in proportion than this, the amount paid to them is wholly inadequate to offset the loss of revenue that they have suffered as a result of the diversion to the mails of much traffic which formerly moved by freight or express. On the basis merely of the cost per mile of moving mail cars the operating expense incurred by the railways in handling these shipments of fruit from Farmington to Gallup was at least \$100; and this includes nothing for overhead charges, such as return on investment, or for the expense incurred in delivering the fruit from the Gallup station to the postoffice. Adding these would make the total expense incurred by the railways about \$140, which is not far from twice as much as the revenue received by the postoffice department. If, in addition, there be added the expense incurred by the postoffice department in handling the shipments, it will be seen that the parcel post rate was probably not one-third large enough to cover the total cost of the service rendered. The present express rate between Farmington and Gallup is \$4.40 per 100 lbs. The Interstate Commerce Commission, in its recent order, holds that a reasonable rate is \$2.95. If this is a reasonable rate by express it must be a reasonable rate by parcel post, but the parcel post rate applied on these shipments figures out only \$1.20 per 100 lbs. It is, therefore, evident that the government could not by any possibility handle the business except at a heavy loss if it paid the railways a reasonable compensation for the services they render in handling the parcel post traffic; and railway men suspect that it is a realization on the part of postoffice department officers that the parcel post rates are entirely unremunerative that causes them to delay readjusting the mail compensation of the railways.

**BELGIAN RAILWAYS FOR CHINA.**—M. Devos, representing the Belgian syndicate which secured the concession for the Kweichow Lauchow Railway, has, it is reported, signed another important contract, which provides for the construction of a railway from Kwei-hua-cheng to Tatung, Tai-yuan and Cheng-tu, a distance of over 1,000 miles.

**IMPORTANT COLOMBIAN LINE PROPOSED.**—The Congress at Bogota is said to have authorized the Colombian government to construct a railway which will connect the Magdalena river with northern Santander Department, with its terminus at San Jose de Cucuta, Colombia. Efforts have been made for over 50 years to secure construction of some sort of a transportation route that would bring Cucuta into closer communication with the interior and more heavily populated portions of Colombia. Should this road be constructed and the short remaining distances between Medellin and Cali be closed, Colombia would have a transcontinental railway and river connection from east to west, which could not fail to be an important factor in the development of the entire country. It is not known whether the government will undertake the construction of this road on its own account or whether it will grant a concession therefor to foreign capitalists.

**NEW LINE FOR HONDURAS.**—The railway from Truxillo to Juticalpa, Department of Olancho, Honduras, with branch line to Tegucigalpa, will be constructed by the Truxillo Railroad Company, an American corporation in which the United Fruit Company is substantially interested. The railway will probably be built along a different line from that of the old Honduras National Railroad, and new material from the United States will be used. Work was begun on June 25, and it is intended to complete the line to the Aguan river—about 11 miles—by the end of this year. A 50-foot wharf for landing material has been built, and the right of way toward the Aguan river is being cleared. The terminal and permanent wharf will be located at the part of Truxillo Bay known as the Rincon which is considered an excellent place for a wharf, at which large steamers can lie sheltered against practically all weather. This point is about five miles from the city of Truxillo, to which a spur will be built.

# ALASKA'S NEED OF RAILWAY DEVELOPMENT.

Inadequacy of the Existing Lines and Proposed Improvements to Open Up the Great Natural Wealth of the Region.

By E. E. SWERGAL,  
New York Central & Hudson River.

Much has been written and said regarding the need of transportation development in Alaska. Regarding all great questions, agitation and interchange of views in a reasonable measure are desirable, but there is always a point where these should end and decisive action begin. That point has already been reached in the controversy regarding the development of transportation in Alaska. Probably a large majority of the writers and politicians who have written of and discussed

months of personal observation and investigation are necessary before one can arrive at reasonably safe conclusions regarding the internal questions, and the climatic, domestic and business conditions involved.

Let us briefly review the history of transportation development in Alaska; what has been accomplished and what remains to be accomplished. We will go back to the building of the White Pass & Yukon, the first railway in Alaska.

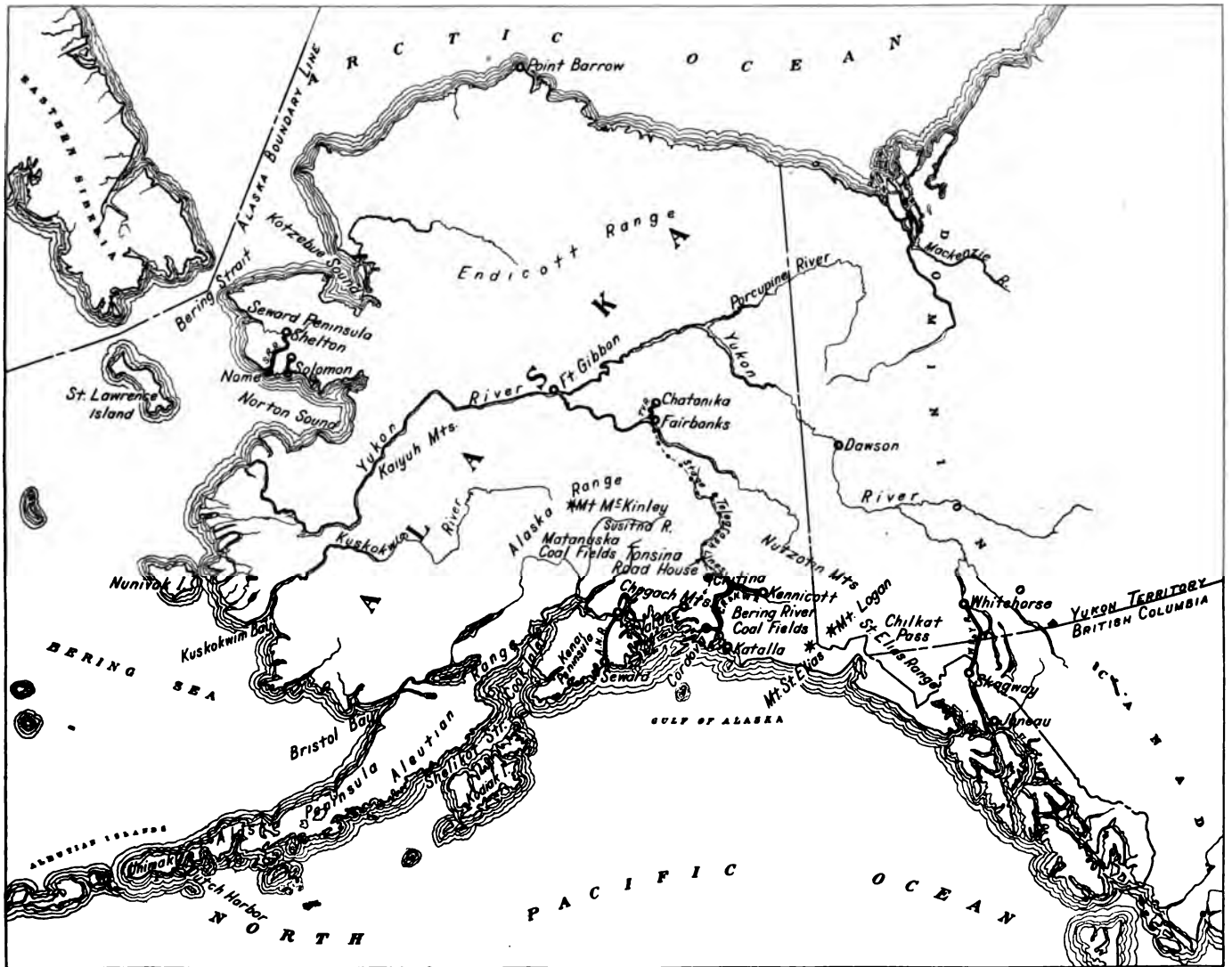

Alaska, Showing the Few Railroads Now in Operation.

Alaska's transportation question, and other internal affairs, have never even visited Alaska.

I will venture the assertion that there are not more than five newspaper and magazine writers of those who have written and talked upon the subject, who could be considered competent to judge. Of these five, two are American magazine writers of national reputation. Of the political men of prominence who have written of or discussed the question within the last three years, five or six only have visited the country, and of that number four remained only a few days in the coast section, which is the part of Alaska upon which the controversy has centered. In Alaska, as in any frontier country,

The discovery of gold placers in the Yukon valley, and the consequent influx of a large population resulted in the building of the White Pass & Yukon, a narrow gage line, in 1898-1900, to a point on the head waters of the Yukon river, from which stern-wheel steamers connected with the noted placer town of Dawson in the Canadian Yukon, at that time the chief center of gold production. This line extends 112 miles in a northeasterly direction from Skagway, Alaska, which is situated at the head of Chatham strait (commonly known as Lynn canal). Only 25 miles of this railroad is within Alaska, the greater portion being in British Columbia and Yukon territory, with a terminus at the town of White Horse.



With the discovery of the Fairbanks, Alaska, gold area, the copper belt of the Chitina river, the coal deposits at the head of the Matanuska river and in the vicinity of Cordova, and the oil deposits near Katalla, there came a popular demand for an all-American route from the southwestern coast of Alaska to the interior.

Here a brief sketch of the physical geography of the southwestern coast is necessary to a clear understanding of the difficulties encountered in the projection of railway lines into the interior. Generally speaking, this is a bold curve, swinging northwest from the islands of southeastern Alaska, then in a generally westerly direction, embracing the islands of Prince William sound, and finally sweeping southwesterly along the Alaska peninsula and the Aleutian islands, the western-most islands being within a few hundred miles of the Kurile islands of Japan.

This crescent configuration of coast line is shown on the accompanying map and largely governs the northeasterly flow of the warm Japan current, which results in greatly modified climatic conditions in Alaska, not generally found in far northern latitudes.

About 50 miles back from the coast along Prince William sound the Chugach mountains parallel the coast line, rising to an altitude of from 5,000 to 8,000 ft., from which innumerable spurs project to the ocean, where they present precipitous faces and form an irregular broken country studded with many glaciers of varying size. The culminating peak of these mountains is St. Elias, which rises to an altitude of 18,000 ft., and the largest glacier is the Malaspina, which has a sea frontage of 40 miles. So absolute has been this mountain barrier to communication between the coast and interior that even the fauna and flora are different, and it has even affected the migration of the Indians and the dissemination of their languages.

Through this coast several railroads have been projected and championed, those most discussed having their initial points at Katalla, Cordova, Valdez and Seward. These coast towns are twelve to fifteen hundred miles distant from Seattle by sea. Of the several railroads projected, two only have been built and operated through this coast range, the Copper River & Northwestern and the Alaska Northern, both standard gage lines.

The tidewater terminus of the Copper River & Northwestern is at Cordova on the easterly shore of Cordova bay, a commodious and land locked harbor which affords facility for commerce at all seasons of the year, and at all stages of water. The main line extends from Cordova in a northeasterly direction through the Copper river valley, to the town of Chitina. At this point, 132 miles from the coast, a branch extends in an easterly direction through the Chitina valley to the Kennecott copper mines, 65 miles distant at the head of the Kennecott river. At Chitina connection is made with the military sled and wagon road over which stages are operated to the well known mining town of Fairbanks, situated about 300 miles north on the Tanana river above its confluence with the Yukon. From mile 38 on the main line surveys have been run to the Bering river coal fields across the Copper river delta, a distance of about 50 miles.

This railroad is on a water level grade, and of a high order of construction, modernly equipped for operation, and with but little interruption successfully carries passengers, freight and mail throughout the year. It is noted for its engineering and scenic features, a combination of which is much in evidence at the third crossing of the Copper river on mile 49, where a \$1,500,000 cantilever, steel bridge carries the line across the stream, which here passes diagonally between the noted Miles and Childs glaciers. Modern steel bridges are also located on miles 27, 30 and 149; the latter being a cantilever bridge 250 ft. above the gorge of the Kuskulana river.

The tidewater terminus of the Alaska Northern is at Seward, Kenai Peninsula, on the northwest shore of Resurrection bay (a splendid all-year harbor), and by steamer about 150 miles

west of the noted mining town of Valdez. The line has been constructed and operated a distance of 70 miles in a northerly direction from Seward, and has afforded facility of movement for prospectors and miners developing the country tributary thereto. In a measure, it also serves those who are interested in the agricultural possibilities of the Susitna river district to the north. This river has its head waters immediately to the east of Mt. McKinley in the Alaskan range.

In a program of construction to the interior, the lines already constructed could properly serve as entrances from the coast, with any additions and betterments that may be found necessary, and with the construction of laterals to permit of development of the coal deposits. To the north of the coast mountains through which these railways have been built, a generally rolling tundra surface country is encountered. Reconnaissance lines have been run through this inland country, and it has been roughly estimated that construction to the Tanana and Yukon rivers will cost \$25,000 per mile.

There are one or two short narrow-gage lines in Alaska, which are of no real importance and which have no bearing on the general development question as it is now understood. One of these lines is the Tanana Valley Railroad, which runs from Fairbanks to Chatanika, and which serves locally between Fairbanks and the placer creeks. This line might possibly be connected up with the north and south lines to be built into Fairbanks, but this is not very probable, because the Tanana valley is narrow gage. The Solomon River Railroad is also a short narrow-gage line and runs from Nome to the local mining fields. This line only operates during the three summer months.

Space forbids extended remarks bearing upon the engineering and physical difficulties which were encountered in the construction of the railroads referred to, but it is not extravagant to say that from time to time, in various ways, action of a Napoleonic character was required, and at no time did the men engaged show a disposition to evade the issue. Many of the original questions of engineering and construction have now been solved by the men who pioneered the way, and upon this foundation of recorded experience the men who follow can solve their problems more rapidly, and perhaps obtain results at less financial cost and personal hazard than those who preceded them.

These railroads were financed by private capital and although costing many millions of dollars, and much personal anxiety and hardship to the officers and their subordinates, the enterprises were indirectly hampered in various ways through the agency of unscrupulous or uninformed magazine and newspaper writers, and by subtle and self centered politicians.

The federal government has not encouraged private enterprise in the development of transportation, and supplementing this indifference it has placed an unjust burden on development by the imposition of a mileage tax of \$100 per mile of main line built and operated. One of the lines referred to (200 miles long), is thus compelled to pay the federal government \$20,000 per year, notwithstanding the heavy expenses of maintenance and operation encountered in a country of this character, which can only be partially supported by light traffic earnings derived from an undeveloped country.

Regarding the pointed question as to who can best develop the transportation for the common good of all, it appears to be the consensus of opinion of the men who know the country best that the work should be continued by private enterprise, as has been permitted in the states, and with equitable financial assistance and regulation by the government. The Interstate Commerce Commission now has jurisdiction in Alaska, and considering the agitation that has been engendered by this question, there is little probability, if any, of corporation abuses being practiced or even attempted in the future. Many of the railroads built in the states were liberally assisted by the government, therefore, why should not assistance (stripped of political and financial abuses) be extended to private railway enterprises in Alaska?

As regards actual construction and ownership by the govern-

ment, some people raise objections, generally to the effect that the cost would impose an indirect and unprofitable burden upon the tax payers of the United States proper, inasmuch as the development is wholly within Alaska and ostensibly for the direct benefit of its people. This primary objection sounds substantial at first thought but when facts and figures are analyzed the results do not support it.

It is commonly known that Alaska was purchased from Russia in 1867 for \$7,500,000. Since then there has been taken out of the territory not less than \$350,000,000 in diversified products, mainly gold, copper, furs and fish, a profit on the purchase of approximately 4,500 per cent. This profit has been absorbed in the national wealth of the United States through various avenues of commercial interchange. There remains in Alaska great potential wealth in the same products, and in addition thereto the anthracite and bituminous coal deposits are untouched, lack of development alone standing between the coal and the warming of homes and production of energy for industrial purposes along the Pacific seaboard of the United States. This coal will tend to lessen the cost of domestic and commercial fuel by reason of additional competition in the market.

As regards possibilities of agriculture in the districts adjacent to railroads already built and proposed, there is some doubt as to the successful production of grains; corn probably never will be grown because of the absence of long hot seasons so indispensable to the growth of this product. Wheat, oats, and barley have been experimented with in the Tanana and Susitna valleys for the purpose of home consumption, and although some success has been obtained, there is ever present the hazard of destruction by frost due to the shortness of the summer season. Grass grows rapidly and in abundance during the early summer, and there is no doubt but that with proper attention sufficient hay can be produced for domestic purposes. The government has established experimental agricultural stations in the districts susceptible to cultivation, but it remains to be seen whether or not grains can be grown with certainty.

As regards the climatic effects upon railroad operation in Alaska, experience has demonstrated that operation can be successfully conducted, and although intermittent interruption has occurred on the lines already under operation during the winter months, the hazard and interruption has not been more serious, if as much so, as in the operation of lines during winter months through the mountainous sections of our western states.

Through the coast ranges of Alaska snow rotaries are necessary for operation during a portion of the winter, usually in January, February and a portion of March. This necessity, however, will become less marked as the hazardous points are determined by experience, and fortified by sheds, fences, grade reinforcement, or other improvements. Beyond the mountain ranges trains are being successfully operated during the winter months with the aid of pilot plows and flangers only, as the snowfall rarely exceeds two or three feet in the valleys, which is much less than the precipitation encountered, in the form of rain or snow, along the coast. This disparity is accounted for by the prevailing warmth along the coast due to the influence of the Japan current.

Regardless of obstacles encountered up to the present time in the maintenance and operation of Alaskan railroads, there is much hope for the future, as experience has demonstrated that all railroads, wherever their location may be, during early years of maintenance and operation are subject to trouble in greater degree than is the rule in later years, when sufficient time has elapsed to permit of substantial adjustment through a gradual co-ordination of physical features.

Reverting to the question of government ownership, the government has expended many millions of dollars, and many lives have been lost in the military and civil administration of the Philippines, Hawaii, Porto Rico and Cuba, in the development of the islands for the direct benefit of alien people, with no substantial proof that its efforts have been understood and appreciated, and

with no assurance that in the end a reasonable profit will be realized on the expenditure.

Contrast this with what we have found in Alaska. Alaska has already contributed immensely to our national wealth and there still remains vast wealth to be developed. It is a "white man's country" in every sense that the term implies; there is no country where white men grow hardier and healthier. These men have undergone hardships as did the pioneers in the early days of our western states, and in return they have been neglected, even imposed upon, by their government.

Summed up, the burdensome results of national political quarrels and governmental indifference have fallen upon the people of Alaska to such an extent that many of them have been forced by idleness to leave the country, many have failed in their small business enterprises, mining development has been seriously retarded and the development and extension of railroads discontinued. The present population does not exceed fifty thousand, including native Indians and Eskimos, and this in a country famed for its natural wealth and in extent of territory one third of the size of the United States proper.

What is needed as a remedy is the adoption by the government of a definite and businesslike development program, embracing five general items: (1) Early development of railroads by private enterprise, assisted and regulated by the government, or wholly undertaken by the government. (2) Revision of mining laws, particularly coal land laws, to permit of practical and early development. (3) More liberal appropriations to the army engineers (who have charge of highways and telegraph and cable lines), to enable them to effect a more rapid extension of trails, and for the substantial bridging of streams at dangerous fords. (4) A comprehensive plan for additional fixed aids to navigation along the coast. (5) Construction of fortified coaling bunkers for naval and merchant vessels at a practicable harbor on the southwestern coast. The latter item is a gravely important one when we consider the possibility of an American-Asiatic war. Results of expert investigation have demonstrated that Alaskan coal is as good for steaming purposes as are the best qualities of coal found in the eastern states.

Railroads, however, are the first and most important need, for without them the potentiality of the country cannot be developed. In view of the nominal amount Alaska cost us, considering the immense profit we have already derived, and well knowing what the country still holds in store for us, why should we hesitate longer to substantially aid in the work of development?

We should no longer hesitate! The necessity for decisive action has long since confronted us, and we should now act with decision and good judgment to the credit and profit of ourselves and posterity.

**TRANS-SIBERIAN RAILWAY.**—At a recent railway conference the representative of the Canadian Pacific Railway asked that the Korean railways should be connected with the regular through services of the Trans-Siberian Railway, and that the same arrangement should be effected with the railways of Northern China. This proposal has now been adopted, and Seoul and Peking are now on the regular round-the-world itinerary via Russia and Canada.

**RAILWAY IMPROVEMENTS IN EGYPT.**—Due to Lord Kitchener's initiative a great number of construction works are to be undertaken in Egypt. A new railway line, the exploitation of which has been intrusted to the Egyptian Delta Light Railways, is to unite Dessouk with the region of Foua-Metubes, in the delta. A bridge is to be built across the Nile between Metubes and Edfina. Another bridge to cost \$2,000,000 will cross the Nile between Dessouk and Rahmanieh. Other new lines in course of construction are those between Menouf and Kafe-Zayat and between Tantah and Zagazig. These will traverse two of the most fertile districts in the delta.

**VALUATION OF KANSAS RAILWAYS.**

In accordance with an enactment of the Kansas state legislature passed in 1911, the work of valuing the railway properties within the state as they existed on June 30, 1911, is now being carried on under the direction of the Public Utilities Commission. The first report of the work done to November 1, 1912, prepared by C. C. Witt, engineer of the commission, has recently been published and the following is abstracted from this report.

In carrying on this work the various lines were divided into convenient sections approximately 100 miles long, and the physical items were reported by the roads on blanks furnished by the commission in rotation for each section, beginning at one end and proceeding to the other, each section being complete in itself except as to equipment items, which will be reported for the entire line in Kansas on the basis of the locomotive or car miles made in that state to that made on the entire system. This inventory is required in duplicate, one copy of which is to be filed in the office of the commission and to constitute the railway company's appraisal, while the other is to be used by the engineering department in checking the items in the field.

Right of way maps and profiles covering the entire lines within the state, also blue prints of both the substructure and superstructure of large bridges, standard plans of pile bridges, stock yards and track construction, copies of recent construction contracts and final estimates or other special data that will assist in the determination of a correct and reasonable appraisal, were furnished to the commission by the railways.

To insure uniformity of work the railways operating in this state organized an association and have held frequent meetings, at some of which representatives of the commission have been present. In this way many disputed points have been settled in advance, and the work has been materially simplified.

As soon as the inventories prepared by the railways are received they are carefully checked on the ground by the engineers of the commission, who travel over the line on foot or on gasoline motor cars, making necessary corrections. After this inspection is completed, the report is brought into the commission's office and cost prices assigned to each item. Quantities of grading are calculated from the profiles and right of way acreages from the maps.

The aim of the commission has been to secure the cost of reproduction new and the present physical value. It is hoped to secure the original cost later. In discussing right of way, the report states: "If the appraisal is of 'the cost to reproduce new,' land must be treated as any other item and an estimate made of the cost of securing the right of way, including all severance and other damages, as if the present right of way, station grounds and terminals were not owned by the company but had to be secured by the methods commonly pursued, all improvements and conditions of abutting property being as they actually exist at the date of appraisal. "If the appraisal is of 'the present physical value,' the element of time or past existence of the property as railroad right of way must be considered. The land itself has increased in value in proportion to the increase of abutting property, but the money paid for severance damages, engineering, legal expenses and other expenses of acquisition has not increased and should be stated as of original cost. When once accounted for, this item is settled for all time."

For the purpose of securing the present market value of the right of way and station grounds, if they were devoted to other purposes, the assessed value of all farm land through which the railway extends and of all abutting lands in towns and cities was secured from the Tax Commission and the records in each county. Records of all bona fide sales and assessments years of lands for the last three in the vicinity and of classes similar to those occupied by right of way, were also secured. To determine the amount of probable damages to be paid by the railway, or of multiple cost, records of purchases of right of way and condemnation suits for a number of lines were compiled, and the resulting figures compared with the market value at the time

of the purchase of the land through which the railroad passes. From these figures it appears that the total cost of the right of way for extended sections ranged from 2¼ to 2½ times the market value of the property through which it passes, while individual tracts ranged from donations to 10 times the market value. It was also found that the multiple was larger for farm property than for town property. In small towns and villages the multiple was about 2½; in towns of 10,000 population, a little over 2; while in cities of over 100,000 population, from 1½ to 2.

In depreciating roadway items, the present physical value was determined by inspection, supplemented by theoretical life tables. An item of 4 per cent. of the cost of all roadway items and right of way was added for engineering and engineering superintendence. The present physical value of equipment was determined by depreciation tables based on a study of the average life of a large amount of equipment. An allowance of 9½ per cent. was made for general expenditures, including legal expenses other than those charged to right of way, taxes and assessments levied on the property while under construction, interest during construction, and contingencies. Nothing was allowed for adaptation and solidification of roadbed or for any intangible values.

At the time of this report, the appraisal of the Union Pacific was completed and a general summary is given herewith, the estimated cost to reproduce new per mile being \$37,156 and the estimated present physical value \$27,459 per mile.

**COST TO REPRODUCE NEW AND PRESENT PHYSICAL VALUE, PER MILE, OF EACH ITEM.**

Miles first main track.....			1,187.42
Miles second main track.....			66.87
Miles passing and sidetrack.....			251.75
Miles joint track (0.82).....			.41
<b>Total .....</b>			<b>1,506.45</b>
	<b>Road.</b>	<b>Reproduction cost, new.</b>	<b>Condition, Per Cent.</b>
1. Engineering and engineering superintendence .....		\$857.32	100.00
2. Right of way and station grounds.....		2,723.05	100.00
2a. Severance and other land damages.....		3,873.73	.....
3. Real estate .....		914.97	100.00
4. Clearing, grubbing, grading and protection .....		4,351.24	99.92
6a. Truss, plate girder and I-beam bridges..		1,589.26	87.02
6b. Pile bridges and timber trestles.....		603.97	71.31
6c. Culverts .....		479.75	78.32
7. Ties .....		3,249.39	56.68
8. Rails .....		4,093.94	81.57
9. Frogs and switches, railroad crossings...		141.38	78.89
10. Track fastenings and other material...		955.94	82.39
11. Ballast .....		662.26	84.51
12. Tracklaying and surfacing .....		1,619.85	60.94
13. Roadway tools .....		15.58	70.01
14. Fencing right of way .....		246.19	71.56
15. Crossings and signs .....		90.05	69.88
16. Interlocking and other signal apparatus.		136.88	91.34
17. Telegraph and telephone lines.....		88.00	72.20
18. Station buildings and fixtures.....		639.13	68.09
20. Shops, engine houses, turntables and cinder pits .....		343.72	63.69
21. Shop machinery and tools.....		183.74	55.20
22. Water stations .....		374.96	80.21
23. Fuel stations .....		56.91	69.60
31. Stockyards, snow fences, and miscellaneous structures .....		358.98	75.03
35. Earnings and operating expenses during construction .....		282.04	74.99
<b>Total road items.....</b>		<b>\$28,932.23</b>	<b>72.55</b>
	<b>Equipment.</b>		
37. Steam locomotives .....		\$1,847.43	56.86
39. Passenger-train cars .....		705.57	74.72
40. Freight-train cars .....		1,731.52	68.38
41. Work equipment .....		630.45	66.31
<b>Total, equipment items.....</b>		<b>\$4,914.97</b>	<b>64.70</b>
	<b>General Expenditures.</b>		
43. Law expenses .....		\$144.66	100.00
44. Stationery and printing .....		10.00	100.00
45. Insurance .....		10.00	100.00
46. Taxes .....		67.69	100.00
47. Interest and commission.....		1,015.42	100.00
48. Other expenditures, contingencies, etc...		1,861.59	100.00
<b>Total, general expenditure items....</b>		<b>\$3,109.36</b>	<b>100.00</b>
49b. Stores and supplies, material, etc., for use in Kansas .....		200.00	90.00
<b>Grand total—</b>			
Per mile of first main track.....	\$37,156.56	73.90	\$27,458.60
Per mile of all tracks.....	29,287.72	73.90	21,643.56
If Section No. 1, Kansas-Missouri state line to Topeka, which includes all the double track in this state and the extensive terminals and shops at Kansas City, Kan., is excluded from above totals, the total per mile of first main track will be .....	31,104.95	75.36	23,442.03
<b>Total per mile of all tracks.....</b>	<b>26,668.84</b>	<b>75.36</b>	<b>20,098.78</b>

### PRESSED STEEL CARLINES.

A new style of pressed steel carline has recently been designed by the Cleveland Car Specialty Company, Cleveland, Ohio, for use with steel side plates in car framing. It is necessary that the carline should rest flat on the side plate with a large bearing surface, and the design here shown is now being placed on a large number of cars. While this type is intended for steel

district supervisors of demurrage, whose duty it will be to see that demurrage rules are administered on a uniform basis throughout their respective territories.

This proposed co-operative arrangement will be established on the basis of contracts between the companies. Each railroad joining will agree with all of the others, in the association for that district, to be governed by the rules, to furnish the necessary information and statistics, and to pay a proportion

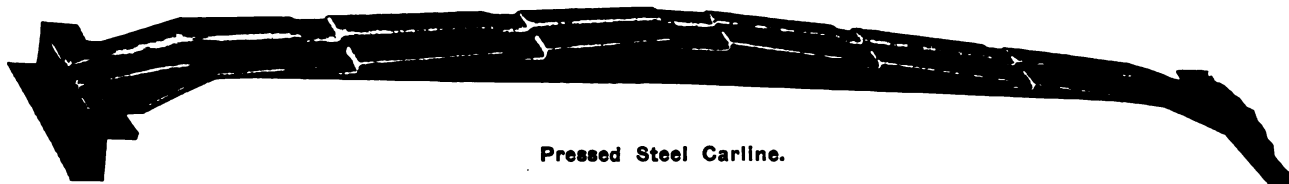

Pressed Steel Carline.

framing, it is equally applicable to cars with wood side plates. A recent test of this carline showed that it required a pressure of over 4,500 lbs. to deflect it when placed upon supports representing the side plates. The use of pressed steel has made it possible to produce a design of carline in which the maximum strength is gained with a minimum weight, as the whole carline can be made from one piece of steel and the metal placed where it is most needed. It is stated that many thousands of Cleveland carlines are now in use, and that no failures have yet been reported.

of the expense of supervision, on the basis of the number of cars handled in the territory supervised, this basis to be determined by the general secretary of the American Railway Association.

Excepting in New England demurrage is now managed throughout nearly the whole of the eastern and central states on an independent basis, each road for itself, all of the old demurrage associations having been disbanded; and even where associations now exist important roads stay out of them.

New England is under the supervision of a commissioner, Mr. Thomason, who is responsible jointly to the railroads and to the Interstate Commerce Commission, the commission being supposed to represent the shippers and consignees; but the cost of maintenance of the bureau is borne wholly by the railroad.

The other parts of the country which are under the supervision of joint commissioners, under the associations or bureaus established a number of years ago, are shown by the numbered sections in the accompanying map. Those parts of the map which are shaded represent areas now without supervision. The principal roads in the organized territory which have withdrawn from the demurrage associations are the Chicago &

### PROPOSED EXTENSION OF DEMURRAGE AGREEMENTS.

The American Railway Association, by letter ballot, the result of which was announced by Secretary W. F. Allen, August 11, has voted to authorize the supervision of freight car demurrage rules throughout the country by its Committee on Relations between Railroads, Arthur Hale, chairman. This committee, with the approval of the executive committee, will appoint

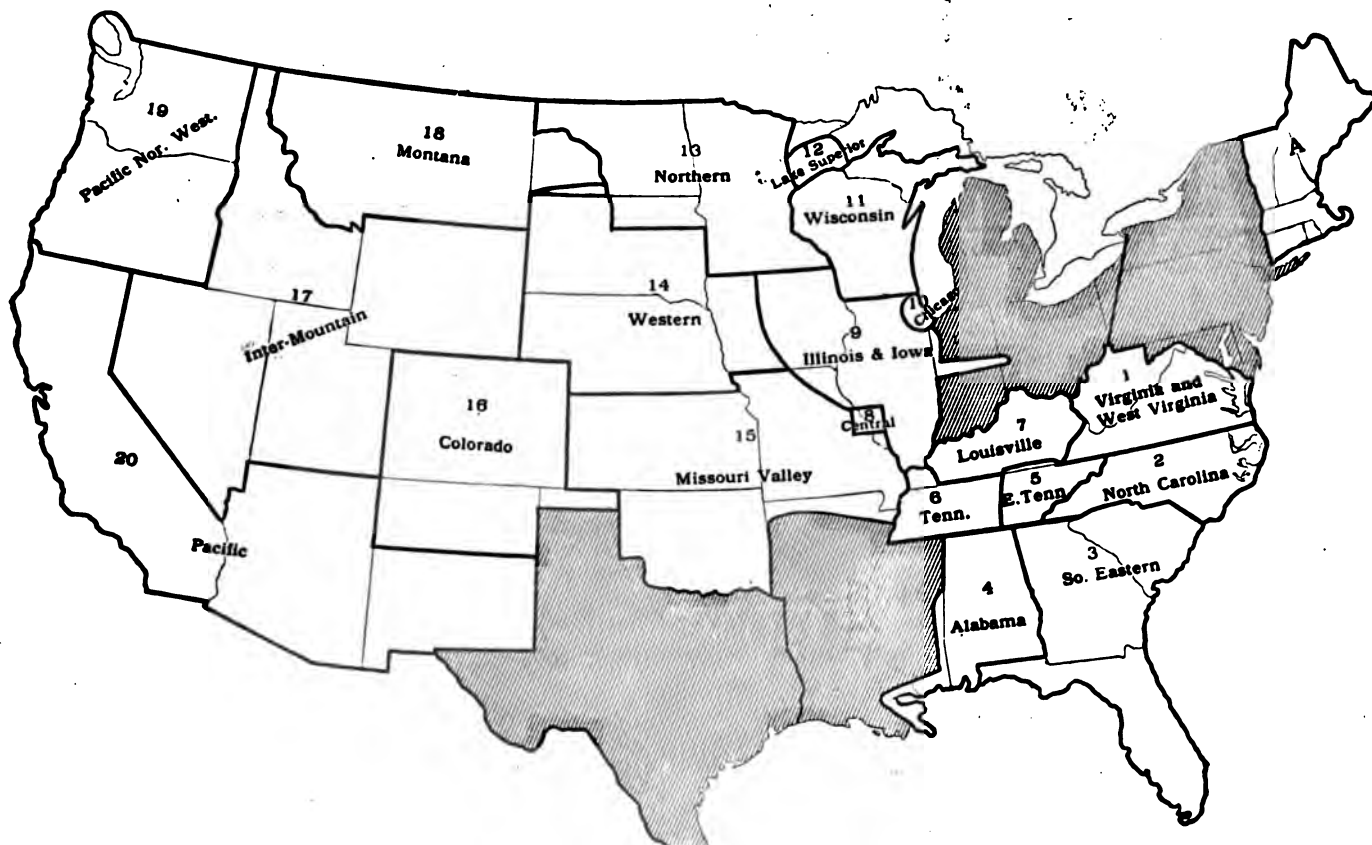

Shaded Portions Have No Demurrage Commissioners.  
Administration of Freight-Car Demurrage Rules.

Alton; Chicago & Eastern Illinois; Chicago, Indiana & Southern; Chicago, Terre Haute & Southeastern; Duluth, Missabe & Northern; Elgin, Joliet & Eastern; Illinois Central; Kansas City Southern; Minneapolis & St. Louis; Missouri, Kansas & Texas; St. Louis & San Francisco; St. Louis Southwestern; Toledo, St. Louis & Western; Vandalia.

The A. R. A. committee will endeavor to secure signatures to the proposed new contract in those territories which are not now organized.

### DEAD LINE FOR STATION PLATFORM.

The photograph shows an effective method employed by the Chicago, Rock Island & Pacific at the Englewood station, Chicago, to warn passengers on the platform of the danger in standing too close to the track when trains are approaching the station. The platform is located at the end of a 3 deg. 30 min. curve which increases the danger both of being struck by the train and by coal falling from the tender of the locomotive, the latter being more frequent on account of the curvature of the track. As this station does a heavy business, both through and suburban, it was selected as the best location at which to give



Safety Sign and Line at Englewood Station, Chicago.

the method described a thorough trial. A white line, 7 in. wide, was painted on the brick platform 6 ft. from the nearest rail, and prominent signs were painted in large red letters on a white background reading "Danger—Keep Back of Line—Watch Your Children." These signs are hung from the under side of the roof of the umbrella shed, at intervals along the platform. So far this scheme has proven effective. These dead lines could be installed in the building of new platforms with white tile, brick or other material, depending on the character of the material, thus eliminating any maintenance cost.

**NEW BRIDGE OVER THE NILE.**—The bridge which has for many years carried the main line of the Egyptian State Railway over the Damietta branch of the Nile at Mansurah, a town in Lower Egypt about 84 miles down the river from Cairo, has recently been replaced by a structure more suitable for modern train loads. At this bridge the Nile has a mean width of 130 yds. in the low water season, and 240 yds. at flood season. The new bridge is composed of four spans, three of which are fixed and of uniform dimensions, while the fourth, the second from the Mansurah side, is of the movable swing type. The turning and wedging motions of the swing span are worked by hand.

## General News.

The new all-steel ferry steamer *Edward T. Jeffery*, built for the Western Pacific, for service on San Francisco Bay and launched on July 19, is now in service between San Francisco and Oakland.

The Baltimore & Ohio, following conferences extending over several weeks, in regard to a number of complaints concerning working conditions in the shops, has come to a satisfactory agreement with the members of the machinists' union employed by the company.

The shops of the Trinity & Brazos Valley at Teague, Tex., including a number of cars and locomotives in the shops for repairs, were almost totally destroyed by a fire supposed to have started from an electric wire, on August 26. The loss is estimated at \$225,000. It is announced that the shops will be rebuilt at once.

The North Western University School of Commerce, Chicago, has announced a course of thirty-two lectures on transportation to be given on Friday evenings from 7 to 9 o'clock, from October 1 to June 1. The course is designed to give the student a general knowledge of the transportation field as well as a detailed knowledge of the principal problems in transportation. The lectures will be given by Professor Secrist and will be grouped under the following heads: First semester, the American railway system, the railway service, the railroad and the public; and the railroad and regulation. The work of the second semester is primarily concerned with railway rates and regulation. The main topics considered are the theory of railroad rates, rate-making and practice, personal and local discriminations, freight classification, rate systems and the regulation of interstate commerce.

Charles S. Mellen, late president of the New York, New Haven & Hartford, has been retained by the directors in an advisory capacity for three years, at \$30,000 a year. This statement is published on the authority of a member of the executive committee, who says that this action was taken in July, when Mr. Mellen's resignation as president was accepted. The directors felt that to keep Mr. Mellen within calling distance was only common prudence. As president, Mr. Mellen's salary was \$60,000 a year until a few years ago, when it was reduced to \$54,000 at the time that all of the executive officers voluntarily submitted to a reduction of 10 per cent. The report concerning Mr. Mellen's salary also has it that Mr. Tuttle, chairman of the board of directors of the Boston & Maine and formerly president of that road, had his salary of \$30,000 continued during the year when, at the end of his term, he had leave of absence (1911) and that he now receives a comfortable salary as chairman; but that probably he will soon retire in favor of Mr. Elliott, the new head of the New Haven road. Mr. Mellen, while president of the Boston & Maine and the Maine Central, received no salary for his services in those positions.

### Nothing New Under the Sun.

Sixty-two years ago, 1851, the Boston & Maine in its annual report said:

"The treasury of a railroad seems to be considered like a city carried by assault, the proper arena and admitted apology for plunder. It is perfectly understood among the profession, that the best feature in a lawsuit is to have a railroad company for an opponent. Judges and juries seem to vie with each other in heaping liabilities and imposing penalties upon them. Each succeeding legislature loads them with new restrictions, imposes new burdens and subjects them to new and unnecessary expenses, while the public are continually crying out for lower charges, greater speed and more frequent and more splendid accommodation. These are facts too notorious for denial, and it is the duty of those to whom the stockholders have intrusted their interest, to point out the dangers as well as the profits of their investments."—*Boston Journal of Education*.

### Life on the Old B. & P.

Conductor H. E. Strout, of the New York, New Haven & Hartford, 73 years old, who has just been pensioned after 49 years of continuous service, gives the press agent of the road

some interesting reminiscences. He entered the service of the Boston & Providence in 1860, at the age of 20, as a brakeman, at seven dollars a week. In 1862, he enlisted in the Fourth Massachusetts Infantry, and served under General Banks in Louisiana. On July 14, 1863, he was wounded in the assault on Port Hudson, but completed his enlistment. He resumed his position with the road as brakeman in October, 1864, at \$1.50 per day, later increased to \$2. In March, 1871, he was promoted to the position of passenger conductor at a yearly salary of \$1,000. At this time no money was deducted on account of sickness or absence from work, and no extra compensation was given for special trips.

"There were no local trains then out of or into Boston later than 6:30 p. m., with the exception of a theater train from Dedham, which ran once a week. The first Sunday train on the road, with the exception of the New York night mail train, was put on in July, 1871, and I was conductor of it for a number of years. There were no ticket offices open, even in Boston, for this train. We collected fares from every passenger and no rebates were given. Even the superintendent of the road was obliged to pay his fare. I collected about \$100 to \$150 each Sunday. There was no silver money at this time, it being all scrip, and this I carried between my fingers in order to make change rapidly. My regular run was three round trips daily between Boston and Dedham, 11 miles, stopping at all stations, leaving Boston at 8:30 a. m., 12:00 and 5:00 p. m., and returning from Dedham immediately upon arrival. On the morning and night trips we carried five or six cars, but on the noon trip only three.

"A few of the coaches held about 60 people, but not more than this number. There was no smoking car, but there was a 4-wheel baggage car. After much importunity on the part of the passengers, the company finally did take an old fish-car and fit it up with settees, and this was used for a smoking car. The cars were lighted by two kerosene lamps, one at each end of the car, with wicks about an inch in width; and at night conductors had to carry lanterns in collecting fares." For the past ten years Mr. Strout has been running the train leaving Boston at 3 p. m. for New York. He is a member of the G. A. R., the Order of Railroad Conductors, and Masonic bodies.

**Applications for Engineering Positions with the Federal Railway Valuation Commission.**

No work in recent years has attracted the attention of railway engineers to such an extent as has the valuation of railways being undertaken by the Interstate Commerce Commission, and for this reason positions with this commission have attracted far more than the usual number of applicants. Information regarding the examinations and the positions with their respective salaries was given in the *Railway Age Gazette* of June 20, page 1579. The number of applications received for the various positions with the salaries accompanying these positions is given below:

	No. of Applicants.	Salaries.	
		Grade 1.	Grade 2.
Senior Structural Engineer.....	703	\$3,000 to \$4,800	\$1,800 to \$2,700
Structural Engineer .....	44		1,080 to 1,500
Senior Civil Engineer .....	3,024	3,000 to 4,800	1,800 to 2,700
Civil Engineer .....	640	1,200 to 1,500	720 to 1,080
Senior Inspector of Car Equipment	262		1,800 to 3,600
Inspector of Car Equipment.....	295		1,200 to 1,500
Senior Electrical Engineer .....	488	3,000 to 4,800	1,800 to 2,700
Electrical Engineer .....	132		1,080 to 1,500
Senior Inspector of Motive Power.	475		1,800 to 3,600
Inspector of Motive Power.....	271		1,200 to 1,500
Senior Railway Signal Engineer...	146	3,000 to 4,800	1,800 to 2,700
Railway Signal Engineer.....	50		1,080 to 1,500
Senior Mechanical Engineer .....	425	3,000 to 4,800	1,800 to 2,700
Mechanical Engineer .....	63		1,080 to 1,500
Senior Architect .....	239	3,000 to 4,800	1,080 to 1,500
Architect .....	11		1,080 to 1,500

The fact that no examinations were required for positions paying over \$1,800, doubtless had the effect of bringing out many applications from men who would not be sufficiently interested to take the examination at some central point. Likewise, undoubtedly many men made application for the positions paying \$3,000 to \$4,800, to whom only the highest positions would be an inducement.

**Melons by the Million.**

Whoever thinks that the sailing ship is no longer an adjunct of Baltimore commerce will be informed of his mistake by paying a visit to municipal dock No. 5. During the current week this dock has been literally crowded with sloops, schooners and other sailing craft, all loaded to the gunwales with watermelons. There have been times during the week when there have been as many as 100 shiploads of watermelons at the dock at the same time. There have probably been more than 1,000 shiploads of watermelons delivered to Baltimore from along the two shores of the Chesapeake since the beginning of August.

Some of these vessels are equipped with gasoline engines, but most are sailboats. After the trucking season is over this fleet will go into the oyster business. Wheat and corn are brought to Baltimore on sailboats, just as they were a hundred years ago. During the past 10 days trainloads of watermelons have been shipped out daily to the mining regions of Pennsylvania and to northern cities.—*Baltimore Star*.

**A Letter of M. W. Baldwin.**

The letter dated April 3, 1849, a fac-simile of which is shown below, was written by M. W. Baldwin of Philadelphia, the father of the Baldwin Locomotive Works. It is of interest, not alone because of the distinguished name attached to it, but also from the fact that John S. Cook, the man in whose favor it was written, was in active railroad service for about 64

*John S. Cook is one of the young men I have employed for years as bookkeepers. He has just finished his apprenticeship at my shop & I cheerfully recommend him as a good workman as well as temperate & steady. I hope his employment by you will be to your mutual advantage.*

*M. W. Baldwin*

years, and until a few weeks ago. The death of Mr. Cook is announced in another column of this paper.

In a letter to a friend in Philadelphia, written nine years ago, Mr. Cook explained that the reason the Baldwin letter had remained in his possession, was that one other man of a party of five presented his letter to the prospective employer and that that one had answered for the whole party. The party consisted of J. Robinson, J. R. Seeley, David Hennessey, P. Rice, and Mr. Cook. Mr. Cook said that the Baldwin letter, except for the signature, was written by George Burnham, Senior.

**Disastrous Collision at North Haven, Conn.**

In a rear collision of passenger trains on the New York, New Haven & Hartford, two miles north of North Haven, Conn., on the morning of the second of September, 23 passengers were killed and 30 or more injured, three sleeping cars being wrecked. The collision occurred in a dense fog about 6:55 a. m. The cause seems to have been the failure of an engineman to run under proper control approaching a stop signal in a fog.

Both trains were filled with passengers returning from New England summer resorts, the leading train having ten sleeping cars and the following train five, all Pullman cars; and all of the cars were wooden.

The line at the point of collision, which is about nine miles north of New Haven, is straight and the grade is slightly descending. Southbound train No. 91, the Bar Harbor Express,

second section, was stopped at automatic block signal No. 23, because of the presence of a local passenger train in the section ahead. Having made a full stop the engineman started forward; then, as soon as the whole train had passed beyond the signal and into the next block, the conductor signaled the engineman to stop, or slacken, in order to enable the rear flagman, who had gone back, to regain the train. The collision occurred, however, before he had reached the last car. When some distance away he heard the following train approaching and at once started back a second time. The length of time consumed in the stop at signal 23, and of the stop after passing it; and also the distance which the flagman had gone back, are elements in the situation, concerning which, as yet, the testimony is not clear.

The second train was the first section of No. 95, the White Mountain Express. It had passed Wallingford, the last station preceding, about eight minutes behind the second section of No. 91. Engineman Miller, of the White Mountain train, says that on approaching signal No. 23 he shut off steam about a mile back; but it appears that he was running about 40 miles an hour when he came in sight of the preceding train, which was moving very slowly forward. Miller applied the brakes and he slackened the speed somewhat before striking the train ahead. His engine, a new one, weighing about 125 tons, completely demolished the two rear cars and lifted up and overturned the third car from the rear; and did some damage to the fourth. Few, if any, passengers were injured ahead of the fourth car, and none were seriously injured in the second train.

The signals on this part of the road are enclosed disks, installed by the railroad company, about 25 years ago. When originally installed there were no distant signals and no overlaps; and so far as can be learned, from the testimony thus far available, there was no distant indication on the day of the collision. It seems to be admitted that the engineman received a clear signal indication at the last signal before reaching signal No. 23; and the fact that the preceding train had cleared No. 23 only about 100 ft. or less, seems to indicate that there was no overlap.

Engineman Miller's testimony, so far as it can be made out, is to the effect that he saw signal 23, saw the rear end of the preceding train, and encountered the torpedoes of the flagman, all at about the same time.

Engineman Miller has been in the service of the road since 1899 and an engineman since 1903; and this was his regular train.

The transcript of the engineman's time previous to the accident is as follows:

"Engineer Miller ran No. 96 on Saturday, August 30, arrived Springfield and released from duty 12:55 a. m. Sunday, August 31.

"Had twenty-eight hours and twenty-seven minutes to rest—Sunday layover.

"September 1 called at Springfield 5:22 a. m. to run No. 95 to Stamford. Left Springfield 6:12 a. m. Arrived Stamford 9:27. Put engine away 9:42 a. m. Total time on duty, four hours and twenty minutes.

"Rest period at Stamford, 11 hours 38 minutes.

"September 1—Called Stamford 9:20 p. m. for 2-96 and arrived Springfield 1:17 a. m. Put engine away and released 1:37 a. m. Total time on duty, 4 hours 17 minutes.

"Rest period at Springfield, 3 hours 6 minutes.

"September 2—Called Springfield 4:43 a. m. for 1-95. Wreck occurred North Haven 6:55 a. m., after he had been on duty 2 hours 12 minutes.

"Above show total 10 hours 49 minutes worked from 12:55 a. m. August 31, until 6:55 a. m. September 2, 1913."

A preliminary statement issued by the road contains the following:

"Flagman Murray says that he went back promptly with proper signals and was recalled by the engine whistle. In the meantime his train had started and was stopped by Conductor Adams to wait for him after the rear end had cleared signal 23. Before he reached the rear of his train he heard the following train approaching. He stopped, started back and was 450 ft. from the rear of his train and about 400 ft. from signal 23 when first 95 passed him. He states that he placed two torpedoes on the rail approximately six telegraph poles from the rear of his train.

"Conductor Bruce C. Adams, in charge of second 91, states that he left Springfield 1 hour and 13 minutes late. He lost between Springfield and the point of the accident on the running time of this train fifteen minutes on account of running slow in the fog. When the train stopped on account of signal 23, he immediately got off, saw his flagman start back, and as soon as the brakes were released the train started. He estimates that approximately two minutes elapsed from the time that the train first stopped until it started, and approximately two to four minutes at the second stop before the collision occurred. Conductor Adams is 35 years old, and has been for nineteen years in service as freight brakeman, flagman and conductor, about one year as conductor on passenger trains."

#### Fourteen Passengers Killed on the Midland Railway of England.

In a rear collision of passenger trains on the Midland Railway, near Hawes Junction, in the north of England, September 2, fourteen passengers and an engine driver were killed and 30 passengers were injured. Several coaches were demolished and the wreck quickly burst into flames. Many of the passengers were burned, and it was believed that many of the injured persons taken out of the wreck had sustained fatal injuries by the flames. The trains were southbound, the first and second sections of the Scotch express for London. They left Carlisle about 2 a. m., and the collision occurred before daylight. The first section had been stopped at the foot of a grade.

#### Co-operation to Prevent Car Shortage.

W. A. Garrett, vice-president of the Chicago Great Western, has issued a circular to agents, yardmen, trainmen and shippers and receivers of freight, urging co-operation to increase car efficiency, as follows:

"We are confronted with a car shortage, and the consequent loss of revenue can only be prevented by co-operation.

"Agents can help by giving immediate notice of arrival to consignee in accordance with the tariff and impressing on patrons the necessity of promptly releasing cars; by promptly placing all cars on which disposition is furnished; by having necessary repairs made at once to defective cars and promptly ordering material needed for this purpose; by promptly unloading company material; by prompt handling of refused shipments; by not ordering more cars than can be loaded promptly; by avoiding the light loading of merchandise cars; by the substitution, as far as practicable, of one class of equipment which is plentiful for another class which is short; by seeing that loaded cars are billed and moved promptly; by keeping chief despatcher informed as to delayed loads and empties.

"Trainmen and yardmen can help by spotting cars promptly for loading and unloading; by reporting, switching and moving empties not needed for immediate loading; by looking out for defects and giving prompt notice of repairs needed, especially calling attention to repairs which may require transfer of lading; by consolidating light merchandise cars; by seeing that cars are moved without delay.

"Shippers can help by making requests for cars in writing and giving as much advance notice as possible; by not ordering more cars than needed for immediate loading; by not taking advantage of the full free time allowed for loading and by giving immediate notice when car is loaded; by loading cars promptly and to full capacity, which is 10 per cent. above marked capacity, and by seeing that sufficient products are on hand to load cars to capacity; by avoiding the use of cars for storage while waiting for deliveries to complete carloads.

"Everybody can help by giving cars preferred attention at all times."

#### American Society of Civil Engineers.

The first regular business meeting of the American Society of Civil Engineers for the season of 1913-14 will be held September 3. Two papers will be presented for discussion, as follows: The Storage of Flood-Waters for Irrigation: A Study of the Supply Available from Southern California Streams, by A. M. Strong, Assoc. M. Am. Soc. C. E.; and Modern Pier Construction in New York Harbor, by Charles W. Staniford, M. Am. Soc. C. E. These papers were published in the May, 1913, *Proceedings*.

ceedings. A discussion on Mr. Strong's paper, by Charles H. Lee, Assoc. M. Am. Soc. C. E., and discussions on Mr. Staniford's paper by Messrs. E. G. Walker, Edwin J. Beugler, and Harrison S. Taft, will be presented.

**American Railway Safety Association.**

A meeting of the American Railway Safety Association to perfect its organization will be held at the Hotel La Salle, Chicago, at 1 p. m. on September 22. A. W. Smallen, chairman of the general safety committee of the Chicago, Milwaukee & St. Paul, who was elected temporary chairman of the association at a preliminary meeting several months ago, expects representatives of at least fifty railways to attend the meeting.

**Canadian Railway Club.**

At the next meeting of the Canadian Railway Club, to be held September 9, a paper will be presented by A. Crumpton, assistant engineer, Grand Trunk Railway, entitled Railway Efficiency. There will also be an election of members to fill the places made vacant by the resignation of C. Murphy and D. Crombie, from the executive committee.

**New York Railroad Club.**

At the next regular meeting of the New York Railroad Club, to be held September 19, William Walter Wheatley will present a paper on Railway Economy Versus Political Economy.

**MEETINGS AND CONVENTIONS.**

*The following list gives names of secretaries, dates of next or regular meetings, and places of meeting.*

- AIR BRAKE ASSOCIATION.—F. M. Nellis, 53 State St., Boston, Mass.
- AMERICAN ASSOCIATION OF DEMURRAGE OFFICERS.—A. G. Thomason, Boston, Mass. Convention, May 19, 1914, St. Louis.
- AMERICAN ASSOCIATION OF GENERAL PASSENGER AND TICKET AGENTS.—W. C. Hope, New York. Annual meeting, October 14-15, Philadelphia, Pa.
- AMERICAN ASSOCIATION OF FREIGHT AGENTS.—R. O. Wells, East St. Louis, Ill.
- AMERICAN ASSOCIATION OF RAILROAD SUPERINTENDENTS.—E. H. Hartman, St. Louis, Mo.; 3d Thursday and Friday in May.
- AMERICAN ELECTRIC RAILWAY ASSOCIATION.—H. C. Donecker, 29 W. 39th St., New York.
- AMERICAN ELECTRIC RAILWAY MANUFACTURERS' ASSOC.—H. G. McConnaughy, 165 Broadway, New York. Meetings with Am. Elec. Ry. Assoc.
- AMERICAN RAILWAY ASSOCIATION.—W. F. Allen, 75 Church St., New York. Next meeting, November 19, 1913, Chicago.
- AMERICAN RAILWAY BRIDGE AND BUILDING ASSOCIATION.—C. A. Lichty, C. & N. W., Chicago. Convention, October 21-24, 1913, Montreal.
- AMERICAN RAILWAY ENGINEERING ASSOCIATION.—E. H. Fritch, 900 S. Michigan Ave., Chicago.
- AMERICAN RAILWAY MASTER MECHANICS' ASSOCIATION.—J. W. Taylor, Old Colony building, Chicago.
- AMERICAN RAILWAY TOOL FOREMEN'S ASSOCIATION.—A. R. Davis, Central of Georgia, Macon, Ga.
- AMERICAN SOCIETY FOR TESTING MATERIALS.—Prof. E. Marburg, University of Pennsylvania, Philadelphia, Pa.
- AMERICAN SOCIETY OF CIVIL ENGINEERS.—C. W. Hunt, 220 W. 57th St., New York; 1st and 3d Wed., except June and August, New York.
- AMERICAN SOCIETY OF ENGINEERING CONTRACTORS.—J. R. Wenlinger, 11 Broadway, New York; 2d Tuesday of each month, New York.
- AMERICAN SOCIETY OF MECHANICAL ENGINEERS.—Calvin W. Rice, 29 W. 39th St., New York.
- AMERICAN WOOD PRESERVERS' ASSOCIATION.—F. J. Angier, B. & O., Baltimore, Md. Next convention, January 20-22, 1914, New Orleans, La.
- ASSOCIATION OF AMERICAN RAILWAY ACCOUNTING OFFICERS.—C. G. Phillips, 143 Dearborn St., Chicago. Annual meeting, May 28, Atlantic City, N. J.
- ASSOCIATION OF RAILWAY CLAIM AGENTS.—J. R. McSherry, C. & E. I., Chicago.
- ASSOCIATION OF RAILWAY ELECTRICAL ENGINEERS.—Jos. A. Andreucetti, C. & N. W. Ry., Chicago. Annual convention, October 18-24, Chicago.
- ASSOCIATION OF RAILWAY TELEGRAPH SUPERINTENDENTS.—P. W. Drew, 112 West Adams St., Chicago.
- ASSOCIATION OF TRANSPORTATION AND CAR ACCOUNTING OFFICERS.—G. P. Conard, 75 Church St., New York.
- ASSOCIATION OF WATER LINE ACCOUNTING OFFICERS.—W. R. Evans, Chamber of Commerce, Buffalo, N. Y. Annual meeting, October 8, Philadelphia, Pa.
- BRIDGE AND BUILDING SUPPLY MEN'S ASSOCIATION.—H. A. Neally, Joseph Dixon Crucible Co., Jersey City, N. J. Meeting with American Railway Bridge and Building Association.
- CANADIAN RAILWAY CLUB.—James Powell, Grand Trunk Ry., Montreal, Que.; 2d Tuesday in month, except June, July and Aug., Montreal.
- CANADIAN SOCIETY OF CIVIL ENGINEERS.—Clement H. McLeod, 413 Dorchester St., Montreal, Que.; Thursday, Montreal.
- CAR FOREMEN'S ASSOCIATION OF CHICAGO.—Aaron Kline, 841 North 50th Court, Chicago; 2d Monday in month, Chicago.

- CENTRAL RAILWAY CLUB.—H. D. Vought, 95 Liberty St., New York; 2d Thurs. in Jan. and 2d Fri. in March, May, Sept., Nov., Buffalo, N. Y.
- CIVIL ENGINEERS' SOCIETY OF ST. PAUL.—L. S. Pomeroy, Old State Capitol building, St. Paul, Minn.; 2d Monday, except June, July, August and September, St. Paul.
- ENGINEERS' SOCIETY OF PENNSYLVANIA.—E. R. Dasher, Box 704, Harrisburg, Pa.; 1st Monday after 2d Saturday, Harrisburg, Pa.
- ENGINEERS' SOCIETY OF WESTERN PENNSYLVANIA.—E. K. Hiles, Oliver building, Pittsburgh; 1st and 3d Tuesday, Pittsburgh, Pa.
- FREIGHT CLAIM ASSOCIATION.—Warren P. Taylor, Richmond, Va.
- GENERAL SUPERINTENDENTS' ASSOCIATION OF CHICAGO.—E. S. Koller, 226 W. Adams St., Chicago; Wed. preceding 3d Thurs., Chicago.
- INTERNATIONAL RAILWAY CONGRESS.—Executive Committee, 11, rue de Louvain, Brussels, Belgium. Convention, 1915, Berlin.
- INTERNATIONAL RAILWAY FUEL ASSOCIATION.—C. G. Hall, 922 McCormick building, Chicago. Annual convention, May 18-22, Chicago.
- INTERNATIONAL RAILWAY GENERAL FOREMEN'S ASSOCIATION.—Wm. Hall, 829 West Broadway, Winona, Minn.
- INTERNATIONAL RAILROAD MASTER BLACKSMITHS' ASSOCIATION.—A. L. Woodworth, Lima, Ohio.
- MAINTENANCE OF WAY & MASTER PAINTERS' ASSOCIATION OF THE UNITED STATES AND CANADA.—W. G. Wilson, Lehigh Valley, Easton, Pa.
- MASTER BOILER MAKERS' ASSOCIATION.—Harry D. Vought, 95 Liberty St., New York.
- MASTER CAR BUILDERS' ASSOCIATION.—J. W. Taylor, Old Colony building, Chicago.
- MASTER CAR AND LOCOMOTIVE PAINTERS' ASSOC. OF U. S. AND CANADA.—A. P. Dane, B. & M., Reading, Mass. Annual meeting, September 9-12, Ottawa, Can.
- NATIONAL RAILWAY APPLIANCE ASSOC.—Bruce V. Crandall, 537 So. Dearborn St., Chicago. Meetings with Am. Ry. Eng. Assoc.
- NEW ENGLAND RAILROAD CLUB.—W. E. Cade, Jr., 683 Atlantic Ave., Boston, Mass.; 2d Tuesday in month, except June, July, Aug. and Sept., Boston.
- NEW YORK RAILROAD CLUB.—H. D. Vought, 95 Liberty St., New York; 3rd Friday in month, except June, July and August, New York.
- NORTHERN RAILROAD CLUB.—C. L. Kennedy, C. M. & St. P., Duluth, Minn.; 4th Saturday, Duluth.
- PEORIA ASSOCIATION OF RAILROAD OFFICERS.—M. W. Rotchford, Union Station, Peoria; 2d Thursday.
- RAILROAD CLUB OF KANSAS CITY.—C. Manlove, 1008 Walnut St., Kansas City, Mo.; 3d Friday in month, Kansas City.
- RAILWAY BUSINESS ASSOCIATION.—Frank W. Noxon, 2 Rector St., New York. Annual dinner, second week in December, 1913, New York.
- RAILWAY CLUB OF PITTSBURGH.—J. B. Anderson, Penna. R. R., Pittsburgh, Pa.; 4th Friday in month, except June, July and August, Pittsburgh.
- RAILWAY ELECTRICAL SUPPLY MANUFACTURERS' ASSOC.—J. Scribner, 1021 Monadnock Block, Chicago. Meetings with Assoc. Ry. Elec. Engrs.
- RAILWAY FIRE PROTECTION ASSOCIATION.—C. B. Edwards, Mobile & Ohio, Mobile, Ala. Next meeting, October 7, Chicago.
- RAILWAY GARDENING ASSOCIATION.—J. S. Butterfield, Lee's Summit, Mo.
- RAILWAY DEVELOPMENT ASSOCIATION.—W. Nicholson, Kansas City Southern, Kansas City, Mo.
- RAILWAY SIGNAL ASSOCIATION.—C. C. Rosenberg, Bethlehem, Pa. Convention, October 14, Nashville, Tenn.
- RAILWAY STOREKEEPERS' ASSOCIATION.—J. P. Murphy, Box C, Collinwood, Ohio.
- RAILWAY SUPPLY MANUFACTURERS' ASSOC.—J. D. Conway, 2135 Oliver bldg., Pittsburgh, Pa. Meetings with M. M. and M. C. B. Assocs.
- RAILWAY TEL. & TEL. APPLIANCE ASSOC.—W. E. Harkness, 284 Pearl St., New York. Meetings with Assoc. of Ry. Teleg. Supa.
- RICHMOND RAILROAD CLUB.—F. O. Robinson, Richmond, Va.; 2d Monday except June, July and August.
- ROADMASTERS' AND MAINTENANCE OF WAY ASSOCIATION.—L. C. Ryan, C. & N. W., Sterling, Ill. Convention, September 8-12, 1913, Chicago.
- ST. LOUIS RAILWAY CLUB.—B. W. Frauenthal, Union Station, St. Louis, Mo.; 2d Friday in month, except June, July and Aug., St. Louis.
- SIGNAL APPLIANCE ASSOCIATION.—F. W. Edmonds, 3868 Park Ave., New York. Meeting with annual convention Railway Signal Association.
- SOCIETY OF RAILWAY FINANCIAL OFFICERS.—C. Nyquist, La Salle St. Station, Chicago. Annual meeting, September 23-25, Chicago.
- SOUTHERN ASSOCIATION OF CAR SERVICE OFFICERS.—E. W. Sandwich, A. & W. P. Ry., Montgomery, Ala.
- SOUTHERN & SOUTHWESTERN RAILWAY CLUB.—A. J. Merrill, Grant bldg., Atlanta, Ga.; 3d Thurs., Jan., March, May, July, Sept., Nov., Atlanta.
- TOLEDO TRANSPORTATION CLUB.—J. G. Macomber, Woolson Spice Co., Toledo, Ohio; 1st Saturday, Toledo.
- TRACK SUPPLY ASSOCIATION.—W. C. Kidd, Ramapo Iron Works, Hillsburn, N. Y. Meeting with Roadmasters' and Maintenance of Way Association.
- TRAFFIC CLUB OF CHICAGO.—W. H. Wharton, La Salle Hotel, Chicago.
- TRAFFIC CLUB OF NEW YORK.—C. A. Swope, 290 Broadway, New York; last Tuesday in month, except June, July and August, New York.
- TRAFFIC CLUB OF PITTSBURGH.—D. L. Wells, Erie, Pittsburgh, Pa.; meetings monthly, Pittsburgh.
- TRAFFIC CLUB OF ST. LOUIS.—A. F. Versen, Mercantile Library building, St. Louis, Mo. Annual meeting in November. Noonday meetings October to May.
- TRAIN DISPATCHERS' ASSOCIATION OF AMERICA.—J. F. Mackie, 7122 Stewart Ave., Chicago.
- TRANSPORTATION CLUB OF BUFFALO.—J. M. Sells, Buffalo; first Saturday after first Wednesday.
- TRANSPORTATION CLUB OF DETROIT.—W. R. Hurley, L. S. & M. S., Detroit, Mich.; meetings monthly.
- TRAVELING ENGINEERS' ASSOCIATION.—W. O. Thompson, N. Y. C. & H. R., East Buffalo, N. Y.
- UTAH SOCIETY OF ENGINEERS.—Fred D. Ulmer, Oregon Short Line, Salt Lake City, Utah; 3d Friday of each month, except July and August.
- WESTERN CANADA RAILWAY CLUB.—W. H. Rosevear, P. O. Box 1707, Winnipeg, Man.; 2d Monday, except June, July and August, Winnipeg.
- WESTERN RAILWAY CLUB.—J. W. Taylor, Old Colony building, Chicago; 3d Tuesday of each month, except June, July and August.
- WESTERN SOCIETY OF ENGINEERS.—J. H. Warner, 1735 Monadnock Block, Chicago; 1st Monday in month, except July and August, Chicago.



## Traffic News.

The Great Northern and the Northern Pacific have announced that all passes issued to Montana state officers and their deputies have been revoked.

The Illinois Traction System, operating 500 miles of inter-urban trolley lines in Illinois, has been admitted to membership in the Illinois Freight Association, and will become a party to joint tariffs filed by the association on the same terms as steam railways.

Attorney-General Smith of Minnesota has given an opinion that those who actually paid the freight are entitled to refunds under the decision of the United States Supreme Court in the Minnesota rate case. The opinion was given as the result of petitions that farmers be given the refund on grain shipments; but the attorney-general holds that the freight was actually paid by elevator men or buyers.

The Union Pacific reports that during July the "Denver Special" train No. 11 from Chicago to Denver over the Chicago & North Western and the U. P., arrived at Denver on time thirty times, although the schedule is fast and the distance is more than 1,000 miles; and we are informed that the corresponding train of a competing line, which nearest approached this record, arrived at Denver three times late during the same period. The "Colorado Express" No. 15, from Chicago to Denver, arrived at Denver on time 28 days during the same month.

The Trunk Line railroads expect to file their new freight tariffs, making increases of 5 per cent. in rates generally, on or about October 1, so that if the Interstate Commerce Commission should not suspend the tariffs the advances would go into effect about November 1. The Pennsylvania Railroad has notified the Public Service Commission of the State of Pennsylvania that if and whenever the interstate rates are changed, a change will also have to be made in the rates within the State of Pennsylvania; this in order to maintain the parity now existing as between different commercial communities.

During the colonist fare period, September 25 to October 10, the Union Pacific will again run through colonist special trains, consisting entirely of tourist sleeping cars, from Omaha to San Francisco, on a fast and convenient schedule. These trains will leave Omaha September 26-27-28, and October 9-10-11, six in all. Through tourist sleepers will be carried from Chicago and Omaha to San Francisco, also to Los Angeles via both the Southern Pacific and the San Pedro, Los Angeles & Salt Lake. These special trains have attained popularity since their inauguration by the Union Pacific two years ago, on account of the quick schedule, with convenient connections at Omaha and arriving time in California.

Assistant Attorney-General Fitch of Missouri has announced that a suit will be instituted shortly in the state supreme court to recover from the railways the excess of freight and passenger rates above the rates fixed by law collected by railways in Missouri, while the state rate law was pending in the federal courts, dating from March, 1909. The amount to be refunded has been variously estimated by state officers at from \$10,000,000 to \$20,000,000. The plan is to sue the railroads on behalf of the people of the state and then to make refunds to those who can furnish legal proof of payment of the higher rates. Mr. Fitch has also served notice on the railways that the excess baggage law permits a charge for extra baggage of only 12½ per cent. of the amount of the fare, and that the railways must cease charging 16½ per cent., or a suit will be instituted. He has also announced that an appeal will be made by the Public Service Commission of Missouri to the Interstate Commerce Commission complaining that the railways are discriminating by charging for interstate transportation more than the maximum fare of either of the two states involved. The Wabash, the Missouri Pacific and the St. Louis & San Francisco on August 29 filed new tariffs reducing their excess baggage rate to 12½ per cent. of the passenger fare.

### St. Louis Shippers Want Cars Pooled.

P. W. Coyle, traffic commissioner of the Business Men's League of St. Louis, expresses the position of the League with reference

to the car situation as follows in *Forward St. Louis*, a paper published by the League:

"It is quite apparent that a scarcity of freight cars, and a possible congestion, such as existed in 1907, confronts us. Obviously, it is to the best interests of all concerned that all cars should be loaded and unloaded as promptly as possible, and that every car should be loaded to its maximum capacity. We respectfully urge the shippers to take such action.

"In doing this, however, we wish to direct attention to the fact that we are urging the carriers to so arrange their method of interchange of freight cars, that the shippers may be privileged to use cars owned by the different railroads more indiscriminately, or in other words, that the freight cars of the country should be pooled for more economic use. We believe shippers should contend for this "single unit," or that carriers should permit shippers to load cars, irrespective of their ownership, if the size and character are such as to conform to the order of the shipper.

"There are in use today, approximately, 2,500,000 freight cars, which, we believe, if properly distributed, interchanged on an economical basis, handled more expeditiously through terminals, etc., and loaded and unloaded more promptly by the shippers, would make available sufficient equipment to avoid this shortage and congestion.

"Under the present methods, however, each railroad may, at its option, call in its surplus cars from foreign lines, and restrict their use to its own rails, so that the circulation of freight cars may be said to resemble the currency of the country. The railroad manager scenting a boom in business, calls in his cars and holds them to protect his individual interests, just as the banker scenting a panic calls in his surplus, thus limiting the supply when general circulation is most needed.

"As a practical illustration of another feature, a St. Louis shipper may have an order for one or more carloads, say for Columbus, Ohio, requiring Big Four delivery, and he may have upon the track at his industry one or more Pennsylvania cars of required capacity, etc. In order, however, to comply with the requirements of consignee and conditions at destination, these Pennsylvania cars must be pulled out and New York Central cars placed instead. Multiply this by the thousands of similar cases throughout the country and the inefficiency of the present method is so apparent that 'he who runs may read.'"

### Shippers Fined for Defrauding Railways.

Fines totaling \$11,000 were recently imposed on and paid by Harry C. Shimer and Adolph Fortgang, of the firm of R. B. Shimer & Co., New York, who pleaded guilty to certain counts in indictments brought against them in the United States District Court, Southern district of New York, for bribing railroad employees to furnish names of consignors shipping to other consignees and for obtaining payment from the railroads of false claims for loss and damage on shipments of eggs. In passing sentence the court, in part, stated as follows:

"Mr. Shimer and Mr. Fortgang, if I should actually do what I ought to do in this case, in order thoroughly to vindicate the law and make an example for others, one which would have a salutary effect in deterring others from committing this and like offences, I would fine you enough to take from you and this firm every cent of your ill-gotten gains, and then, in addition to that fine, add a long term of imprisonment; and in this way all who are disposed to indulge in grossly illegal practices to enrich themselves at the expense of others would be taught a lesson—the existence of the law and that punishment is sure to follow.

"This is a serious offence. In many of its aspects it is worse than larceny, because it was obtaining the money of others by fraud and deceit to enrich yourselves. When a criminal goes out with a gun and says to a man, in the darkness of the night, 'Hold up your hands; stand and deliver,' there is an element of manliness and bravery about it which is entitled to more respect than the getting of money in the ways resorted to by you in this case. I trust you feel the sting of this; you ought to; and your offence and punishment will go out to the community, and will become known, and you will consider the publicity as a part of your punishment, and as something that will operate to deter others.

"And now I want to say to you that in foregoing the addition.

of imprisonment, and imposing so light a fine in view of the amount you made by your doings, after all the ends of justice will probably be served and the dignity of the law upheld, but I want to say to you further, and to each of you, that so far as is within my power I will see, and I know that the United States attorney and his able assistants will see, and that the United States attorneys wherever they are and wherever an offence might be indictable, will see—and this is a warning and not a threat—that if you should offend against the law again in these respects, you need not expect to escape with a fine, for surely the penalty will be not only a heavy fine, but a long term of imprisonment, justly earned by a repetition of such an offence as this.”

**INTERSTATE COMMERCE COMMISSION.**

**Oyster Shipments from Baltimore.**

*Atlantic Packing Company of Baltimore City et al. v. American Express Company et al. Opinion by Commissioner Marble:*

In this case the complainants asked the commission to require the respondent express companies to perform pick-up service for express shipments of oysters at Baltimore. They also asked reparation. The express companies now maintain receiving stations at various points in Baltimore, to which oysters are brought by shippers, and from which they are taken to the loading platforms by the express companies. Only one-third of the oyster shippers in Baltimore prefer a pick-up service to the present method. The commission found that in other cities this pick-up service was supplied, but under conditions dissimilar to those at Baltimore. The commission decided that the tariffs of the respondents should be changed so that they would plainly state the extent as to territory and commodities of the pick-up and delivery service at Baltimore; also that there is no undue discrimination in the present Baltimore arrangement of receiving oyster shipments, but that new receiving stations should be built at points which would be easily accessible to the complainants. Reparation was denied. (28 I. C. C., 244.)

**Rates on Wooden Lard Tubs Reduced.**

*Southwestern Woodware Company v. Chicago, Milwaukee & Puget Sound et al. Opinion by the commission:*

On January 26, 1911, the defendants reduced rates on wooden lard tubs, in carloads from Tacoma, Wash., to Chicago and other eastern points, but raised the minimum to 41,500 lbs., regardless of the length of the car. The lower rates and higher minimum were suspended on April 22, 1911, and the higher rates and lower minimum weight were continued in the tariffs. The complainant contends that the higher rates are unreasonable in themselves and that the minimum of 41,500 lbs. applicable to shipments under the reduced rates is unreasonable because, except in rare instances, the traffic cannot be loaded to that weight. The complainant asks that the carrier be required to apply a minimum weight of 34,000 lbs. to the lower rate or to restore to the tariff, naming the lower rate and higher minimum, the two-for-one rule. The commission decided that the higher rates were unjust and unreasonable and that the minimum rate of 41,500 lbs. in connection with which the lower rates are applied is also unreasonable. The commission prescribed lower rates for the future and decided that 31,500 lbs. was a reasonable minimum weight for the traffic for cars 41 ft. long, and correspondingly lower or higher for cars under or over that length. Reparation was denied. (28 I. C. C., 237.)

**STATE COMMISSIONS.**

J. L. Harrop has been appointed chief engineer of the Missouri Public Service Commission with charge of grade crossing elimination.

Petitions for additions and changes in the Illinois commissioners' classification of freight will be considered at a meeting of the Illinois Railroad and Warehouse Commission, to be held in Chicago on September 10.

The Pennsylvania Public Service Commission has recommended that as the steps or sideboards on some of the open

street cars operated by the Wilkesbarre Railway Company are too high, the company shall erect platforms at the regular stops; and for other places must provide step boxes where necessary.

The Kansas Public Utilities Commission has filed a complaint with the Interstate Commerce Commission against sixty-seven railroads, charging discrimination in freight rates on a large number of commodities from Galveston and New Orleans in favor of Kansas City and Omaha as against Kansas communities.

The Wells Fargo & Company's Express has made application to the California State Railroad Commission for rehearing on its recent order reducing express rates. The Southern Pacific has also filed a petition for a rehearing of the case, stating that the Southern Pacific is not a principal stockholder of Wells, Fargo & Co., but on the contrary does not own any stock in the express company.

The Kansas City Board of Trade on August 26 filed with the Missouri Public Service Commission a complaint charging that several railroads are violating the maximum freight law by charging higher than the legal rates on grain reconsignated at Kansas City. The commission issued an order calling upon the roads to show cause why they should not be enjoined from charging higher rates on reconsignated grain.

**COURT NEWS.**

The attorney-general has begun suit in the district court at Philadelphia to annul the control of the Philadelphia & Reading over the Central of New Jersey, attacking the present relations of the companies under the anti-trust law, and also under the commodities clause of the Interstate Commerce law. It will be recalled that in the decision of the Supreme Court, in the anthracite coal cases, a few months ago, the relations of the Reading with the Central of New Jersey were not passed upon; that part of the subject was dismissed without prejudice. The questions left unsettled at that time are the basis of the present suit.

**RAILWAY DEVELOPMENT IN GREECE.**—Discussing the reception of King Constantine in the capital the Athens newspapers say that, after the impending demobilization, the country must work at the organization of a settled administration and the development of Greece's new territories. Apart from joining up Greek railways with the European lines, the Greek system must be extended throughout the kingdom.

**LIGHT RAILWAYS IN JAPAN.**—The British vice-consul at Yokohama reports that numerous light railways have been constructed during the last few years, and there are now within the consular district of Yokohama no less than 271 miles of light railways, while another 238 miles are either under construction or consideration. So far, he adds, nothing further has been heard regarding the scheme for converting the Tokaido railway track into a standard gage system, which was first mooted several years ago, but subsequently abandoned owing to the enormous outlay it would involve.

**BURMA RAILWAYS.**—The Burma Railways Company, Ltd., is hampered by the action of the railroad board, which reflects the attitude of the government of India. The railway board is alternately accused of extravagance and of parsimonious neglect, but the former is neither required nor desired in the case of Burma. The traffic returns of the Burma Railways last year bear eloquent and conclusive testimony to the advantages of a forward policy of railroad building. The number of passengers carried on the main line and the Pegu-Moulmein and Henzada-Kyaungin extensions was 23,966,266, an increase of over 2,000,000 as compared with the previous year. Both on the main line and on the extensions the percentage of expenses to earnings fell, and the percentage of earnings to capital outlay everywhere increased. Figures like these are very satisfactory in themselves and amply warrant the belief that if further extensions were undertaken—and especially if the construction of the through connection to China were placed in the hands of the Burma Railways Company—the financial and commercial benefit to Burma would be large.

REVENUES AND EXPENSES OF RAILWAYS.

MONTH OF JUNE, 1913.

Name of road.	Average mileage operated during period.		Operating revenues.		Maintenance.		Operating expenses.		Net operating revenue (or deficit).	Outside operations, net.	Operating income (or loss).	Increase (or decrease) comp. with last year.
	Freight.	Passenger.	Total.	Inc. misc. structures, equipment.	Traffic.	Trans- portation.	General.	Taxes.				
Atlanta, Birmingham & Atlantic.....	645	\$160,923	\$52,082	\$232,584	\$43,308	\$104,640	\$10,604	\$14,337	\$15,924	.....	\$1,587	\$7,253
Atlantic City.....	167	70,471	166,883	41,590	17,836	104,873	1,214	168,998	78,512	.....	67,281	27,988
Atlantic & St. Lawrence.....	631	87,558	45,886	23,412	13,468	59,912	4,990	110,516	22,312	.....	1,308	29,540
Bangor & Aroostook.....	631	199,728	56,702	273,157	11,242	26,677	7,975	130,459	182,698	.....	144,349	114,948
Boston & Maine.....	2,252	2,307,631	1,373,633	4,048,655	150,253	70,396	236,524	2,882,173	1,166,482	22,753	68,688	345,619
Butte, Anaconda & Pacific.....	90	88,053	12,966	111,019	24,768	45,776	4,064	69,882	41,137	.....	2,000	39,137
Central of Georgia.....	1,924	512,497	299,293	896,420	120,378	381,191	35,720	44,927	128,571	7,219	91,043	74,939
Central New Jersey.....	676	2,262,861	487,006	2,407,234	327,403	715,200	63,194	283,947	1,489,663	7,051	640,675	287,228
Central New England.....	277	252,002	30,298	297,326	66,474	171,983	7,975	14,514	108,526	263	108,526	28,940
Chicago & Eastern Illinois.....	1,275	1,003,158	251,633	1,345,482	211,488	454,288	37,090	43,466	379,706	-1,110	335,130	77,605
Chicago Great Western.....	1,496	849,602	284,319	1,224,843	181,291	438,102	35,040	46,661	344,007	639	297,985	93,438
Chicago, Indianapolis & Louisville.....	617	371,960	138,271	562,638	94,399	223,549	17,954	28,578	122,407	.....	1,264	603
Chicago, Peoria & St. Louis.....	255	94,961	27,469	129,811	24,546	59,145	4,858	4,765	6,029	.....	115	115
Detroit, Grand Haven & Milwaukee.....	191	147,354	63,565	235,875	35,180	113,019	10,908	11,244	32,360	-135	20,981	623
Georgia.....	307	133,264	71,851	221,804	32,042	124,032	8,522	2,950	4,161	.....	7,111	-41,063
Georgia Southern & Florida.....	395	106,087	61,500	194,426	25,956	84,794	9,461	10,660	47,048	.....	36,368	8,245
Grand Trunk Western.....	347	424,752	220,234	686,595	101,459	302,498	22,118	49,776	145,014	-1,653	93,585	25,902
Houston, East & West Texas.....	191	82,031	33,119	122,648	38,150	39,750	4,224	2,978	27,967	.....	24,989	22,242
Houston & Texas Central.....	789	287,275	153,034	477,673	105,439	234,603	17,798	18,208	16,283	-210	2,135	-40,343
Louisville & Nashville.....	4,923	3,285,980	1,095,883	4,668,023	1,269,009	1,714,073	155,352	46,968	710,327	8,745	672,104	-125,873
New York, New Haven & Hartford.....	2,090	2,317,229	2,483,035	5,411,751	594,131	1,614,232	150,507	196,756	2,031,345	-29,263	1,805,326	-236,881
Philadelphia & Reading.....	1,015	3,241,371	664,159	4,027,832	487,717	1,008,103	61,462	33,129	1,496,477	39,497	1,184,941	-18,717
Port Reading.....	21	123,913	.....	128,062	15,681	.....	.....	.....	81,306	7,092	54,901	15,460
St. Louis Southwestern of Texas.....	703	217,188	87,804	330,776	66,284	178,235	18,929	11,229	36,312	-306	43,887	76,009
Southern Pacific Co.....	6,329	4,578,198	2,749,243	7,960,974	763,312	1,249,910	226,935	343,283	3,481,078	-2,375	3,135,420	486,847
Texas & Pacific.....	1,885	758,532	364,692	1,203,513	197,104	456,577	34,766	102,785	30,120	-1,705	84,370	68,205
Union Pacific.....	3,581	2,819,169	937,407	4,198,488	407,751	1,424,424	133,861	136,242	1,950,608	6,139	1,818,570	485,583
Western Pacific.....	937	365,158	131,837	512,861	84,135	179,192	26,230	26,189	161,006	-1,444	133,373	34,133

TWELVE MONTHS OF FISCAL YEAR, 1913.

Atlanta, Birmingham & Atlantic.....	645	\$2,358,795	\$654,988	\$3,243,045	\$529,743	\$183,404	\$135,899	\$164,235	\$566,301	.....	\$402,066	-\$101,259
Atlantic & St. Lawrence.....	167	1,242,448	358,464	1,739,091	260,287	53,479	47,238	152,286	18,105	.....	18,105	43,357
Atlantic City.....	631	769,108	1,317,384	2,205,125	388,851	180,794	15,937	110,702	324,588	.....	324,588	55,137
Bangor & Aroostook.....	631	2,452,468	626,929	3,255,936	493,449	37,386	137,063	110,587	470,675	.....	94,422	149,422
Boston & Maine.....	2,252	28,692,689	16,049,174	48,513,507	5,424,104	7,769,904	1,359,914	2,025,629	10,412,082	187,914	8,574,367	385,260
Butte, Anaconda & Pacific.....	90	1,079,014	133,438	1,330,940	133,891	8,449	36,532	24,638	255,765	.....	231,127	49,506
Central of Georgia.....	1,924	8,803,118	3,828,199	13,854,872	2,020,950	4,210,229	468,007	598,538	3,529,908	73,483	3,004,853	-447,124
Central New Jersey.....	676	2,190,346	530,425	2,840,577	2,785,817	360,570	538,172	1,521,495	10,413,790	-65,611	10,413,790	1,367,408
Central New England.....	277	3,166,658	360,203	3,708,971	350,958	14,786	46,572	124,514	1,743,728	-4,386	1,614,828	35,491
Chicago & Eastern Illinois.....	1,275	11,984,134	2,950,221	16,214,972	2,155,196	3,717,829	489,650	611,844	3,330,304	-25,571	2,692,889	-1,164,869
Chicago Great Western.....	1,496	9,795,074	3,144,884	14,000,618	1,688,800	5,524,434	413,971	439,419	3,740,476	2,293	3,503,968	922,821
Chicago, Indianapolis & Louisville.....	617	4,682,585	1,648,884	6,985,348	1,069,198	2,956,418	170,510	294,039	1,882,007	.....	1,587,938	137,672
Chicago, Peoria & St. Louis.....	255	1,472,750	141,652	1,767,378	118,430	386,112	25,836	26,605	25,429	.....	1,178	-12,939
Detroit, Grand Haven & Milwaukee.....	191	1,350,331	649,349	2,516,327	531,426	1,341,492	63,585	43,727	66,498	-644	66,498	-240,620
Georgia.....	307	2,014,097	882,165	3,117,766	356,275	1,367,372	99,342	35,728	357,862	.....	322,134	-441,361
Georgia Southern & Florida.....	395	1,410,480	830,541	2,566,890	313,480	465,904	112,444	132,838	527,752	339	394,578	-28,535
Grand Trunk Western.....	347	4,777,592	2,328,742	7,476,560	826,430	1,077,613	194,397	378,925	1,819,419	-22,098	1,418,806	47,421
Houston, East & West Texas.....	191	963,311	361,160	1,403,271	336,042	172,826	46,291	42,883	343,839	.....	300,956	11,251
Houston & Texas Central.....	789	3,472,251	1,893,541	6,828,648	1,059,667	2,045,590	204,594	231,516	1,645,519	20,428	1,102,821	44,297
Louisville & Nashville.....	4,923	42,924,952	12,835,658	59,465,699	11,216,889	11,216,889	1,417,140	1,761,626	12,913,621	20,142	12,913,621	-1,808,977
New York, New Haven & Hartford.....	2,090	34,071,975	27,896,300	68,613,503	7,893,090	27,203,271	1,947,999	3,714,756	21,386,164	645,447	18,316,855	-2,107,475
Philadelphia & Reading.....	1,015	4,033,465	7,101,752	50,562,717	4,687,899	16,199,894	734,113	1,300,478	19,126,330	411,432	19,126,330	3,918,517
Port Reading.....	21	1,568,141	.....	1,606,307	132,070	3,210	1,669	121,497	1,045,325	82,497	1,006,325	224,880
St. Louis Southwestern of Texas.....	703	3,270,929	1,109,003	4,700,840	984,258	1,987,455	237,046	131,077	366,614	-2,301	233,236	-1,35,382
Southern Pacific Co.....	6,329	56,399,970	32,028,818	95,335,315	10,151,846	26,697,435	2,596,620	4,379,326	40,663,821	1,502,186	37,886,681	3,297,028
Texas & Pacific.....	1,885	12,407,401	4,513,962	18,078,783	2,376,174	4,207,759	420,759	693,442	3,306,003	29,167	2,583,394	-305,286
Union Pacific.....	3,581	36,230,966	10,529,587	51,586,230	5,667,120	21,916,644	1,400,881	2,036,285	23,171,604	-41,331	21,933,988	3,299,884
Western Pacific.....	937	4,635,631	1,354,083	6,173,628	938,612	359,523	315,094	278,096	1,673,139	-11,635	1,383,408	576,135

† Figures shown here are for period January 1 to June 30.

## Railway Officers.

### Executive, Financial and Legal Officers.

R. J. McCarty, vice-president and auditor of the Kansas City Southern, at Kansas City, Mo., has been appointed vice-president in charge of accounts, and his former position has been abolished. L. J. Hensley, assistant auditor, has been appointed auditor. P. E. Wooley, freight and passenger accountant, succeeds Mr. Hensley, and G. H. Bacon succeeds Mr. Wooley, all with headquarters at Kansas City, Mo.

A. H. Smith, senior vice-president of the New York Central & Hudson River, announces that Howard M. Biscoe has been appointed vice-president in charge of the Boston & Albany, with headquarters at Boston, Mass., succeeding J. H. Hustis, who recently resigned to go to the New York, New Haven & Hartford. Mr. Biscoe for the last two years had been traffic manager of the B. & A. He was born on July 3, 1869, at Westboro, Mass., and was graduated from Yale University in 1892. He began railway work the same year in the ticket auditor's office of the Boston & Albany. In 1893 he went to the Central Vermont, where he had a position in the general freight office. He remained in that position until March, 1896, when he went back to the Boston & Albany



H. M. Biscoe.

and was appointed clerk in the general traffic manager's office. From April, 1898, to May, 1905, Mr. Biscoe was foreign freight agent of the same company at Boston; following which he was appointed general freight agent. From February 15, 1910, to June 3, 1911, he was assistant freight traffic manager, and since that time, as above stated, has been traffic manager of the same road.

### Operating Officers.

F. Price has been appointed superintendent of car service of the Grand Trunk, with headquarters at Montreal, Que.

J. P. Welch has been appointed trainmaster of the Duluth & Iron Range, with headquarters at Two Harbors, Minn.

F. Walker has been appointed car service agent of the Canadian Pacific, Alberta division, with headquarters at Calgary, Alta., succeeding F. T. Anderson, assigned to other duties.

A. F. Moursund has been appointed assistant superintendent of the Galveston, Harrisburg & San Antonio, Houston division, with office at San Antonio, Tex., succeeding T. F. Sharp, resigned.

W. D. Stayton has been appointed assistant superintendent of the Houston East & West Texas and the Houston & Shreveport, with office at Houston, Tex., succeeding J. C. McVea, resigned.

D. H. Rawson, general superintendent of the United States Express Company, at St. Louis, Mo., has been appointed general manager of the Western department, with headquarters at Chicago.

Charles O'Hara, superintendent of the Union Refrigerator Transit Company, at Milwaukee, Wis., has been appointed general manager, and D. J. O'Connor succeeds Mr. O'Hara, with headquarters at Milwaukee.

S. K. Blair, superintendent of the Ft. Wayne division of the New York, Chicago & St. Louis, with office at Ft. Wayne, Ind., has been appointed general agent at Ft. Wayne, and will per-

form such duties as may be assigned by the general manager. E. J. Parrish, superintendent of telegraph, succeeds Mr. Blair. W. L. Blair, assistant to the general manager, has been appointed joint superintendent of telegraph of the Western Union Telegraph Company and the New York, Chicago & St. Louis, with headquarters at Cleveland, Ohio, in place of E. J. Parrish, and the office of assistant to the general manager is abolished. Effective September 1.

L. C. Browne, who has been appointed assistant general manager of the United Railways of Yucatan, with headquarters at Merida, Yucatan, Mex., was born on April 28, 1878, at Gainesville, Fla., and was educated at St. Leo Military College, St. Leo, Fla. He began railway work in 1894 as a check clerk in a local freight agent's office of the Plant System, now a part of the Atlantic Coast Line, and then held various positions in the mechanical department of the same road. In 1898 he went to the Norfolk & Western Steamboat Company, and in 1900 returned to railway work on the Baltimore & Ohio, remaining with that company until 1902. He was appointed secretary to the vice-president and general manager of the National Railways of Mexico in 1903, and subsequently was chief clerk to the general manager of the Tehuantepec National. In 1904 he became secretary to the president of the Veracruz & Pacific, and the following year was appointed secretary to the general manager of the Mexican Railway. From 1906 to 1912, he was chief clerk to the general manager of the same road, and now becomes assistant general manager of the United Railways of Yucatan, as above noted.

Edwin Ivanhoe Ford, whose appointment as superintendent of the Richmond division of the Chesapeake & Ohio, with headquarters at Richmond, Va., has been announced in these columns, was born on April 18, 1871, in Goochson county, Va., and was educated in the public schools. He began railway work in January, 1887, as a water boy on the piers of the Chesapeake & Ohio at Newport News, Va., and later became flagman. The following year he was made lamp tender and switchman, and from 1890 to 1897 was consecutively night yard clerk; day yard clerk; yard conductor, night yardmaster, assistant yardmaster and general yardmaster. In October, 1905, he became trainmaster at the Newport News terminal, and in January, 1909, was promoted to superintendent of terminals at Newport News, which position he held at the time of his recent appointment as superintendent of the Richmond division of the same road, as above noted.



E. I. Ford.

### Traffic Officers.

W. H. Underwood, assistant general passenger agent of the Michigan Central, at Chicago, has been appointed assistant to the passenger traffic manager of the New York Central Lines West, with headquarters at Chicago.

Ira N. Peterson has been appointed agent of the New York Despatch Refrigerator Lines, National Despatch Refrigerator Line and the Chicago, New York & Boston Refrigerator Company, with headquarters at Detroit, Mich., in place of J. F. Baldwin, deceased.

F. C. Eslick has been appointed general agent of the Chicago Great Western at Mason City, Iowa, in charge of freight and passenger traffic. H. K. Hartman has been appointed commercial agent at Detroit, Mich., to succeed T. M. Smith, resigned. A. Kneubuehl succeeds Mr. Hartman as traveling freight agent, with headquarters at New York City, and F. C.

Campbell takes the place of Mr. Kneubuehl as traveling freight agent, with office at Buffalo, N. Y. Effective September 1.

Howard M. Biscoe, traffic manager of the Boston & Albany, at Boston, Mass., has been elected vice-president of the New York Central & Hudson River, in charge of all departments of the Boston & Albany, and his former position has been abolished. E. P. Gardiner, commercial agent of the Boston & Albany, at Boston, Mass., has been appointed assistant general freight agent, with office at South Station, Boston. H. A. Davis, commercial agent at Providence, R. I., has been promoted to commercial agent, with headquarters at Boston, and W. C. Schmidt, traveling freight agent at New Haven, Conn., succeeds Mr. Davis. (See Executive, Financial & Legal.)

E. P. Gardiner, who has been appointed assistant general freight agent of the Boston & Albany, with office at South Station, Boston, Mass., was born on January 31, 1875, at Chelsea, Mass., and after attending the public schools and a commercial school, entered the service of the Boston & Albany on July 6, 1895. He was promoted to contracting agent in September, 1898, then was with the Merchants Despatch Transportation Company until January, 1900, and subsequently was commercial agent at Providence. In February, 1907, he was transferred to Boston as agent of the New York Central Lines, and two years later was appointed commercial agent of the Boston & Albany, which position he held at the time of his recent appointment as general freight agent of the same road, as above noted.

C. F. Stewart, whose appointment as general passenger agent of the Western Maryland, with headquarters at Baltimore, Md., has been announced in these columns, was born at Covington, Ky., and at the age of 15 entered the office of a railway attorney at Cincinnati, Ohio, and later began railway work as a clerk in the general passenger office of the Marietta & Cincinnati, now part of the Baltimore & Ohio Southwestern. He was then consecutively, secretary to the general freight agent of the Pennsylvania Lines; city ticket agent of the Ohio & Mississippi; chief clerk in the general passenger office of the B. & O. S. W., and city ticket agent of the Chesapeake & Ohio, at Cincinnati, Ohio. In 1896 he went to the passenger department of the Southern Railway at Washington, D. C., and in 1901 became chief clerk in the passenger department of the Seaboard Air Line. He was later promoted to assistant general passenger agent of that road at Savannah. In 1909 he was appointed superintendent of the tariff department of the South Eastern Passenger Association at Atlanta, Ga., which position he held at the time of his recent appointment as general passenger agent of the Western Maryland, as above noted.

#### Engineering and Rolling Stock Officers.

Morris A. Zook, has been appointed engineer in charge of the valuation of the Grand Trunk-Wabash joint lines in Canada, with headquarters at Buffalo, N. Y.

A. Copony has been appointed master car builder of the Western lines of the Grand Trunk, with headquarters at Port Huron, Mich., succeeding J. L. Hodgson, transferred.

A. W. Duke has been appointed assistant supervisor of division No. 22, on the Tyrone division of the Pennsylvania Railroad, with office at Osceola Mills, Pa., succeeding C. M. Hursh, promoted.

The authority of F. M. Bisbee, chief engineer of the Western Lines of the Atchison, Topeka & Santa Fe, with headquarters at Amarillo, Tex., has been extended over the St. Louis, Rocky Mountain & Pacific.

A. F. Blaess, assistant engineer of maintenance of way of the Illinois Central and the Yazoo & Mississippi Valley, with office at Chicago has been appointed district engineer of the Yazoo & Mississippi Valley, with office at Memphis, Tenn. J. C. Clifford, roadmaster at Carbondale, Ill., has been appointed district engineer of the northern lines, with headquarters at Chicago, and C. E. Weaver, roadmaster at New Orleans, La., has been appointed district engineer of the southern lines at New Orleans. The two latter offices have just been created and the district engineers will report to the general superintendents. D. W. Thrower, roadmaster at Chicago, succeeds Mr. Blaess. John F. Plott, supervisor at Carbondale, Ill., takes the place of Mr. Clif-

ford. J. F. Watts, supervisor at New Orleans, succeeds Mr. Weaver. W. C. Costigan, roadmaster at Water Valley, Miss., has been transferred to Chicago in place of Mr. Thrower, and R. L. Hazelgrove, assistant roadmaster at Corinth, Miss., succeeds Mr. Costigan.

#### Purchasing Officers.

William D. Stokes has been appointed general storekeeper of the Central of Georgia, with office at Savannah, Ga., succeeding James L. Bennett, promoted.

W. M. Portlock, general storekeeper of the Seaboard Air Line at Portsmouth, Va., has been appointed assistant to the general purchasing agent, succeeding H. C. Macklin, resigned, and D. D. Cain succeeds Mr. Portlock.

James Lewis Bennett, who has been appointed purchasing agent of the Central of Georgia, with headquarters at Savannah,



J. L. Bennett.

same road, with office at Savannah, as above noted.

Ga., as has been announced in these columns, was born on December 17, 1874, at Savannah, and was educated in the grammar schools of his native town. He began railway work as a clerk in the car department of the Central of Georgia in September, 1890, and subsequently held various positions in that department and the mechanical department of the same road until September, 1906. He was then appointed general storekeeper, with headquarters at Savannah, which position he held at the time of his recent appointment as purchasing agent of the

#### OBITUARY.

C. M. Taylor, mechanical superintendent, Second district of the Chicago, Rock Island & Pacific, at Topeka, Kan., who was granted leave of absence on account of illness in July, died on September 3, at Colorado Springs, Colo. He was born on May 25, 1862, and had been with the Rock Island since December 15, 1906, as district master mechanic and mechanical superintendent, and was previously mechanical superintendent of the Western Grand division of the Atchison, Topeka & Santa Fe at La Junta, Colo.

John S. Cook, master mechanic of the Georgia Railroad, at Augusta, Ga., died on August 28, in John Hopkins Hospital, Baltimore, Md. Mr. Cook had been in railroad service sixty-four years, and it is probably safe to say that previous to his last illness he was, in point of years of service, the oldest railroad officer in the United States. He was born on October 5, 1827, at Brooklyn, N. Y., and began railway work in April, 1849, as machinist in the shops of the Central Railroad at Savannah, Ga. Later he was machinist in the shops of the Georgia Railroad at Augusta. From 1850 to 1853 he was a locomotive engineer on that road; then from 1854 to 1878, about twenty-five years, he was foreman of shops. On the election of General E. P. Alexander to the presidency of the Georgia Railroad, in May, 1878, he was made master mechanic, and had held that position ever since. Mr. Cook was well known in the railroad mechanical world and was highly respected. Before entering railroad service he served an apprenticeship at the Baldwin Locomotive Works, and on leaving the Baldwin shops in 1849, he received a testimonial from Matthias W. Baldwin, a fac-simile of which is shown in another column.

## Equipment and Supplies.

### LOCOMOTIVE BUILDING.

THE CHICAGO, BURLINGTON & QUINCY is said to be considering the purchase of a number of Santa Fe type locomotives and a number of Pacific type locomotives. This item has not been confirmed.

THE NORFOLK & WESTERN has ordered one 130-ton electric locomotive from the Baldwin Locomotive Works and the Westinghouse Electric & Manufacturing Company. If this locomotive proves satisfactory 23 of the same type will be ordered by this road.

THE INTERNATIONAL & GREAT NORTHERN has ordered 3 oil-burning consolidation locomotives from the American Locomotive Company. The dimensions of the cylinders will be 22 in. x 30 in., the diameter of the driving wheels will be 57 in. and the total weight in working order will be 217,000 lbs.

THE CARNEGIE STEEL COMPANY, Pittsburgh, Pa., has ordered 4 six-wheel switching locomotives from the American Locomotive Company. The dimensions of the cylinders will be 22 in. x 26 in., the diameter of the driving wheels will be 51 in. and the total weight in working order will be 150,000 lbs.

### CAR BUILDING.

GRAND RAPIDS & INDIANA has ordered 60 steel gondolas from the Cambria Steel Company, and 85 flat cars from the Pressed Steel Car Company.

### IRON AND STEEL.

THE MAINE CENTRAL has ordered 400 tons of structural material from the Phoenix Bridge Company.

THE CINCINNATI, HAMILTON & DAYTON has ordered 11,000 tons of structural material from the American Bridge Company.

GENERAL CONDITIONS IN STEEL.—The orders of the steel corporation for rolled steel products for August were more than 25 per cent. larger than for July. The corporation produced over 1,000,000 tons of these products during August; ingot production was about 5 per cent. more than that of July. A large number of the orders placed during August were for future requirements, which accounts for the increase over July. Orders during the past week have been very meager, but a marked improvement in the buying movement is looked for this month. There has been some price cutting, and consumers are holding off in expectation of further reductions.

### SIGNALING.

The General Railway Signal Company, Rochester, N. Y., has taken a contract for the installation of automatic block signals on the Toronto, Hamilton & Buffalo, from Vinemount, Ont., to Welland, 27 miles. With the completion of this installation the line will be block signaled throughout its length from Hamilton to Welland, 38 miles.

AUSTRALIAN RAILWAY IMPROVEMENTS.—Plans for alterations to be made at the Geelong railway station have been forwarded to the local town clerk. The work, which is to be started soon, will consist of construction of a subway, the erection of new locomotive sheds, the lengthening of the passenger platform and rearrangements of the yard, the whole involving an expenditure of \$500,000.

PARCELS POST IN AUSTRALIA.—As the result of the expansion of the parcels business in Australia, the railway commissioners have had under consideration the establishment of a motor delivery service. During the financial year just closed the revenue derived from the carriage of parcels was nearly \$1,250,000, but it is considered that if facilities for delivery were provided, the receipts would be considerably increased.

## Supply Trade News.

Isham Randolph, consulting engineer, Chicago, has removed his offices to suite 1807, Commercial National Bank building, Chicago.

The Bush type of train shed, invented and patented by Lincoln Bush, E. D., 1 Madison avenue, New York, has been adopted as standard by the Canadian Pacific and will be used to cover the 11 tracks of its new Windsor street station at Montreal, Que.

The Canada Iron Corporation, Fort William, Ontario, has announced its voluntary liquidation. The company has six large plants in Canada, manufacturing car wheels, brake shoes, sewer pipes, etc., and owns several iron mines. It is stated that the company will probably be reorganized.

The Philadelphia Steel & Forge Company, Tacony, Philadelphia, Pa., has just installed in the rolling mill department of its Tacony works a new power plant which will increase the output of finished bars 2,000 tons a month. This company has also installed a heat-treating plant and is specializing on high-grade steels for locomotives, machine tools, etc.

John C. Kuhns, whose resignation as purchasing agent of the Illinois Central and appointment as vice-president of the Burden Sales Company was noted in our issue of August 22, is associated with Fred. Gardner in representing that company, the Pearsall Company, and the Oxweld Railroad Service Company, with offices at 341 Railway Exchange building, Chicago.

Ernest F. Slocum, formerly vice-president of the Safety Car Heating & Lighting Company, New York, has returned to that company as assistant to the president, a position which has not



Ernest F. Slocum.

been filled for some time. Mr. Slocum was born in Newark, N. J., in 1870, and spent his boyhood days in St. Louis, Mo., where he received his early education. He started his business career as a journalist, and was connected with the *New York Herald* and the *Commercial Advertiser*, also of New York. Later he was made director and manager of the *Daily Advertiser* of Newark, N. J. In 1895 he went to the Safety Car Heating & Lighting Company, accepting a position offered him by the late Colonel A. W. Soper. In May, 1907, he was made a vice-president of that company having charge of sales. In October of that year he suffered a nervous breakdown and has been out of business up to the time of his appointment as assistant to the president of the Safety company as mentioned above.

### TRADE PUBLICATIONS.

PROTECTED SHEET STEEL.—The Asbestos Protected Metal Company, Beaver Falls, Pa., has issued an illustrated bulletin describing its "Asbesto-Steel" for roofs and walls, including a large number of installations in railway work.

WELDING APPARATUS.—The C. & C. Electric & Manufacturing Company, Garwood, N. J., has published bulletin No. 513-C on its electric arc welding apparatus. This bulletin is illustrated and gives valuable information on this subject.

COMPRESSORS, DRILLS, ETC.—The Ingersoll-Rand Company, New York, has published a 140-page illustrated catalog of its compressors, drills, pneumatic tools, and accessories. This catalog gives prices, capacities and dimensions, and includes over 20 pages of useful information in tabular form.

## Railway Construction.

**BALTIMORE & OHIO.**—An officer writes that this company is making surveys for the construction of a cut-off between Monongah and Gaston Junction, a point east of Fairmont, W. Va., about two miles. Through business to the west will be routed over the cut-off and the West Virginia Short Line division, instead of through Fairmont and over the Wheeling division. The cut-off will provide easier grades than the existing lines, and will also save a distance of approximately five miles.

**CALIFORNIA, OREGON & EASTERN.**—An officer writes that work is now under way building from Grants Pass, in Josephine county, Ore., southwest to Crescent City, in Del Norte county, Cal., on the Pacific coast, 91 miles. The construction work on 60 miles will be light and on 30 miles the work will be very heavy. There will be 10 steel bridges having an average length of 200 ft., also about 75 trestles and three tunnels. Track has been laid on 14 miles. The company expects to develop a traffic in timber, minerals and farm products. J. M. Meeland, president, W. W. Harmon, chief engineer, Grants Pass. (August 1, page 211.)

**CANADIAN PACIFIC.**—The report of this company for the year ended June 30, 1913, shows that the company has 1,325 miles under construction, on which work is now under way as follows:

Ontario Division.	
Name.	Miles.
Campbellford, Lake Ontario & Western; Glen Tay, to Agincourt....	182.3
Lake Superior Division.	
Interprovincial & James Bay Ry.; from Kipawa, Que., north.....	10.0
Manitoba Division.	
Selkirk Branch; from Gimli, Man., north.....	26.0
Snowflake Branch; Snowflake, Man., west.....	9.0
Virden Branch; Virden, Man., to McAuley.....	36.2
Souris Branch and extension; Boissevain, Man., to Lauder.....	37.0
Saskatchewan Division.	
Estevan Branch; Estevan, Sask., to Forward.....	55.0
Weyburn Branch; from Weyburn, Sask., west.....	205.7
Alberta Division.	
Swift Current North branch; from Swift Current, Sask., north.....	76.7
Coronation north.....	25.0
Stirling East branch; Stirling, Alta., east.....	50.0
Bassano East branch; Bassano, Alta., to Empress.....	118.3
Suffield branch; from Suffield, Alta., southwest.....	82.0
Gleichen branch; Gleichen-Shepard, Alta.....	40.0
Alberta Central; from Red Deer, Alta., west.....	65.0
Kootenay Central; Fort Steele North branch.....	84.0
Calgary & Edmonton; from Lacombe, Alta., east.....	115.2
British Columbia Division.	
Kootenay Central; Golden, B. C., south.....	60.0
Esquimalt & Nanaimo; Osborne Bay Junction, B. C., to Crofton.....	2.6
McBride Jct., to Courtenay.....	45.0
Total.....	1,325.0

Second track work now under way includes the following: Between Islington and Guelph Junction on the Ontario division, 29 miles; between Sudbury, Ont., and Port Arthur on the Lake Superior division, 133 miles; between Brandon, Man., and Calgary, Alta., 178 miles. There will also be 18 miles of second track laid and grade improvements made in connection with the building of the double track tunnel five miles long between Six Mile Creek and the Loop near the summit of the Selkirk mountains, and 139 miles of second track between Revelstoke, B. C., and Vancouver, at various points where it will give the most immediate relief. When this work is finished and the new lines between Regina and Shepard are constructed there will be 200 miles of double track between Sudbury and Port Arthur, leaving 352 miles yet to be laid. Between Port Arthur and Calgary there will be 1,095 miles of double track, leaving gaps aggregating 165 miles, and between Calgary and Vancouver there will be 158 miles of double track, leaving 488 miles to be built.

**CHICAGO, MILWAUKEE & ST. PAUL.**—An officer writes confirming the report that a contract has been given to the Keasel Construction Company, Tacoma, Wash., to build a section on the Puget Sound & Willapa Harbor. The plans call for building from Raymond, Wash., on Willapa harbor east to Chehalis, thence north via Centralia to Maytown, 65 miles. Track has been laid on 10 miles. The company expects to develop a traffic

in lumber and farm products. C. H. Byers, Raymond, Wash., chief engineer of the Puget Sound & Willapa Harbor. (August 15, p. 313.)

**DAKOTA EASTERN.**—Incorporation has been asked for in South Dakota by this company with a capital of \$800,000 to build from Clear Lake, in Marshall county, S. Dak., south through Day county to Watertown in Coddington county, about 48 miles. The incorporators include W. E. Egeland, H. D. Barnett and E. Merhagen, St. Paul, Minn., H. F. Harp and A. E. Chillson, Webster, S. Dak.

**DALLAS, CORSICANA & PALESTINE.**—An officer writes that grading work is now under way and involves handling 30,000 cu. yds. to the mile. The company was organized last year to build from Palestine, Tex., northwest through Anderson and Navarro counties to Corsicana. The maximum grades will be 1 per cent., and maximum curvature 4 deg. The company expects to develop a traffic in lumber, cotton, lignite, etc. L. E. Mitchell, president, Neosho, Mo. H. Hedberg, chief engineer, Dallas, Tex. (August 22, p. 353.)

**DALLAS, FAIRFIELD & GULF.**—An officer writes that the company plans to build from Dallas, Tex., southeast via Ferris, and probably via Kerens, to a point on the International & Great Northern. It has not been determined when contracts will be asked for the work. T. J. Alexander, president, Teague, Tex., and Woolsey Fennell, chief engineer, Tuscaloosa, Ala. (June 27, page 1631.)

**DENVER & SALT LAKE.**—The Denver tunnel commission has submitted to this railway for approval a contract, authorized by a city ordinance, providing for a loan of \$3,000,000 by the city to aid in the construction of the proposed six-mile tunnel under James Peak. A city election to authorize a bond issue for the amount is expected to be held in October. Provision is made so that the company may acquire title to the tunnel.

**DULUTH & IRON RANGE.**—An officer writes that a grading contract has been given to Charles M. Magrison, for work on a logging line from mile 108 near Robinson station, Minn., north to Burnside lake, 3.18 miles. The grading work which involved handling 10,000 cu. yds. to the mile is 90 per cent. completed and the company will carry out the track laying with its own forces.

**ERIE.**—Plans have been submitted by the city engineer of Youngstown, Ohio, calling for the depression of the tracks of the Erie and the Pittsburgh & Lake Erie. It is understood that the plans have been accepted by the railroad companies. A court decision requires these roads to bear 65 per cent. and the city of Youngstown 35 per cent. of the cost of eliminating 12 grade crossings in Youngstown.

**GEORGIA COAST & PIEDMONT.**—An officer writes that the company expects to have the 15 mile extension from Darien, Ga., south to Brunswick, including the four bridges over the Altamaha river, completed about November 1. A contract was given last year to the Glynn County Construction Company to carry out the work. (July 19, 1912, p. 143.)

**HENRYETTA INTERURBAN.**—Application has been made in Oklahoma for a charter to build about 100 miles in Oklahoma. The projected route is from Henryetta to Muskogee on the east and to Okemah and Shawnee on the West. The directors include W. Brink, J. Kincaid, C. J. Harrison and C. H. Kellogg.

**JEFFERSON COUNTY TRACTION.**—This company has finished track laying on the line from Port Arthur, Tex., north to Beaumont, 25 miles. The company is a subsidiary of the Stone & Webster Engineering corporation of Boston, Mass. It is said that the same interests have under consideration the question of building an interurban line between Beaumont and Houston, about 80 miles. The proposed line is to connect at Houston with the interurban line that runs to Galveston, the latter being also a Stone & Webster property. The same interests are building an interurban electric line from El Paso down the valley of the Rio Grande to Ysleta. (September 20, 1912, p. 559.)

**LAKE ERIE & EASTERN.**—See Pittsburgh & Lake Erie.

**LAKE ERIE & YOUNGSTOWN (Electric).**—This company is said to have started work on the line to connect Youngstown, Ohio, with Conneaut, about 65 miles. A. W. Jones, J. H. Ruhlman

and G. M. Brown, Youngstown, are interested. (January 10, page 87.)

**PITTSBURGH & LAKE ERIE.**—Additional contracts for extending the Lake Erie & Eastern from the Brier Hill Steel Company's plant in Youngstown, Ohio, northwest to Niles, have been let to the McKelvey-Hine Construction Company, Pittsburgh, it is said. The contract calls for building a single track line about 10 miles long. (May 31, 1912, page 1221.)

See Erie Railroad.

**PORTLAND, EUGENE & EASTERN (Electric).**—An officer writes regarding the reports that extensions of the Alpine and Bellfountain branches will be built in Oregon, that the company will build an extension about a mile and a half long in connection with some logging operations. One of these branches is about 10 miles long and one about seven miles.

**PUGET SOUND & WILLAPA HARBOR.**—See Chicago, Milwaukee & St. Paul.

**SALT LAKE & ALTA.**—Incorporated in Utah to build a line to the granite quarries in the Little Cottonwood canyon, and to the Alta mining district. Work is now under way between Midvale, Utah, and Wasatch, on about 11 miles up Little Cottonwood canyon. The grading is finished and track has been laid on four miles. J. G. Jacobs, president; F. P. Jacobs, vice-president; E. C. Ashton, secretary and treasurer; George E. Cutler, W. O. Williams, Norman W. Haire and C. W. Blethen, are directors.

**SAN RAFAEL & SAN ANSELMO VALLEY (Electric).**—An officer writes that this company has been incorporated in California with \$100,000 capital. Surveys are to be started in about a month for a three-mile line through the streets of San Rafael, Cal., thence westerly, via San Anselmo to Fairfax, about six miles. The company expects to use Beach storage battery cars on the line. E. S. Rake, president, S. J. Norton, vice-president. San Rafael.

**TORONTO, HAMILTON & BUFFALO.**—An officer writes that this line is being double tracked between Welland, Ont., and Fenwick, six miles, and second track is being laid across the Welland river, where a pile trestle is being constructed adjacent to the present through truss bridge prior to the permanent construction which will be determined when the government has indicated its requirements with regard to draw span. The contractor for the grading is J. L. Boyd, Toronto. The passing sidings between Welland and Hamilton are being lengthened to 75 car capacity westbound and 90 car capacity eastbound. The sidings are lapped to provide convenient layout for operation and signaling. Stone ballasting has been completed and twelve miles of 100 lb. rail are being laid between Vinemount and Hamilton, which includes the mountain section. New 100,000 gal. steel tanks have just been completed at Smithville and at Welland, and two new team yards in Hamilton of 94 cars capacity are about completed.

**VAN HORN VALLEY.**—Plans are being made, it is said, to build a 200-mile line from Lobo, Tex., via Crow Flat into New Mexico. The company has a capital of \$1,500,000. R. H. Owen, president, Minneapolis, Minn. The incorporators include J. M. Daugherty, J. Y. Canon and J. Irby, all of Van Horn, Tex.

**RAILWAY STRUCTURES.**

**WELLAND, ONT.**—See Toronto, Hamilton & Buffalo, under Railway Construction.

**WOONSOCKET, R. I.**—The New York, New Haven & Hartford is carrying out improvements at Woonsocket, to include a new yard covering 10 acres of land, to have 19 tracks; also a new outbound freight house 30 ft. x 400 ft., and an inbound freight house 60 ft. x 400 ft. A two story brick office building is also included in the improvements. Work on the freight houses is nearing completion.

**CHILI AND INTERNATIONAL RAILWAYS.**—The Chilean minister of industry recently announced in the Senate that the government would give no facilities for the construction of international railways as long as no commercial treaties between Chili and the neighboring countries existed.

**Railway Financial News.**

**BALTIMORE & OHIO.**—The New York Stock Exchange has listed an additional \$5,000,000 first mortgage 4 per cent. bonds of 1898-1948. The proceeds of these bonds were used to pay for improvements as follows: Double tracking the Chicago division, \$2,680,485; terminal and yard improvements, \$1,224,011; track elevation, \$584,875; other capital expenditures, \$570,932.

**BRINSON RAILWAY.**—The Georgia railroad commission has approved the issue of \$5,000,000 first mortgage and refunding bonds, a part of which may be used to secure \$1,250,000 2-year 6 per cent. notes. This road runs from Savannah, Ga., to Waynesboro, 96 miles.

**BROOKLYN RAPID TRANSIT.**—N. F. Brady has been elected chairman of the board, succeeding his father, A. N. Brady, deceased.

**CANADIAN NORTHERN.**—This company recently sold in London, at a price to the public of 98 per cent., £1,500,000 (\$7,500,000) 5 per cent. secured notes.

**CANADIAN PACIFIC.**—See editorial comments on the annual report in this issue.

**LAKE SHORE & MICHIGAN SOUTHERN.**—This company has sold in London £420,000 (\$2,100,000) one-year notes dated September 6. The notes were discounted in advance.

**MICHIGAN CENTRAL.**—This company has sold \$2,000,000 one-year 6 per cent. notes dated August 27.

**NEW YORK CONNECTING.**—The New York Public Service Commission has been asked for its approval of an issue of \$30,000,000 bonds, of which \$11,000,000 4½ per cent. bonds are to be deposited as security for \$10,000,000 4½ per cent. 3-year notes. The notes are to be guaranteed principal and interest jointly by the Pennsylvania Railroad and the New York, New Haven & Hartford. The New York Connecting is the road which is building a connection between the New York, New Haven & Hartford and the Pennsylvania's Long Island Sunnyside yards.

**VALDOSTA, MOULTRIE & WESTERN.**—B. P. Jones, A. L. Davis and C. I. Harrell have been appointed co-receivers, Mr. Jones having, as previously announced in these columns, been appointed temporary receiver.

**EXPANSION OF GOVERNMENT RAILWAYS IN AUSTRALIA.**—An addition has been made to the government railway system in western Australia by the state taking over the hitherto privately-owned line from the Margaret river to Flinders bay. This line was used for hauling timber from the forest to the seaboard. It traverses a tract of rich country eminently suited for dairying. It is now the government's intention to make the line part of a big extension of the state system, a project being under consideration for the construction of a railway from the port of Busselton southwards, and of which the newly acquired line will form a link. The Margaret River-Flinders Bay line will be run entirely for the convenience of settlers in the district, but later on will be used to handle the heavy traffic of a much more extensive territory.

**CROP OUTLOOK IN WESTERN AUSTRALIA.**—The outlook for the farmers in western Australia this season is particularly bright. Excellent rains have fallen over the whole of the agricultural areas, and although the season is late there is every promise of a splendid harvest and a record wheat yield. The railway officers are busy preparing for the rapid transportation of the crops to the seaboard. It is hoped that ample provision will be made for rolling stock, or there will be serious financial loss to the revenue of the state and complaints from the farmers similar to what took place lately in the states of Victoria and Queensland. These states have, however, minimized the risk of congestion of future bumper crops by the recent addition of a number of British built locomotives. Although it is the policy of the states to build their own engines, it is difficult with the existing building plant in the states to cope with the demands and rapid agricultural developments.



## ANNUAL REPORT.

## CANADIAN PACIFIC RAILWAY COMPANY—THIRTY-SECOND ANNUAL REPORT—YEAR ENDED JUNE 30th, 1913.

## To the Shareholders.

The accounts of the Company for the year ended June 30th, 1913, show the following results:—

Gross Earnings .....	\$139,395,699.98
Working Expenses .....	93,149,825.83
Net Earnings .....	\$ 46,245,874.15
Net Earnings of Steamships in excess of amount included in monthly reports .....	1,245,563.03
Deduct Fixed Charges .....	\$ 47,491,437.18
Surplus .....	10,876,352.15
Deduct amount transferred to Steamship Replacement Account .....	\$ 36,615,085.03
Contribution to Pension Fund .....	\$1,000,000.00
	125,000.00
	1,125,000.00
	\$ 35,490,085.03

From this there has been charged a half-yearly dividend on Preference Stock of 2 per cent., paid April 1st, 1913 .....	\$1,473,386.53
And three quarterly dividends on Ordinary Stock of 1½ per cent. each, paid January 2nd, 1913, April 1st, 1913, and June 30th, 1913 .....	10,150,000.00
And interest on instalments on New Stock Subscriptions, paid October 15th, 1912 .....	569,813.87
	\$ 12,193,200.40
	\$ 23,296,884.63

From this there has been declared a second half-yearly dividend on Preference Stock, payable October 1st, 1913 .....	\$1,486,626.79
And a fourth quarterly dividend on Ordinary Stock of 1½ per cent., payable October 1st, 1913 .....	3,500,000.00
	\$ 4,986,626.79

Leaving net surplus for the year .....

In addition to the above dividends on Ordinary Stock, three per cent. was paid from Special Income.

## THE FOLLOWING ARE THE DETAILS OF SPECIAL INCOME FOR YEAR ENDED JUNE 30th, 1913.

Balance at June 30th, 1912 .....	\$2,460,790.60
Interest on Cash Proceeds and on Deferred Payments for land sold .....	2,031,785.05
Interest on Deposits and Loans .....	1,201,906.69
Interest on Can. Pac. Ry. 1st Mortgage Bonds acquired .....	63,461.33
Interest from Minneapolis, St. Paul & Sault Ste. Marie Ry. Bonds .....	159,720.00
Interest from Mineral Range Ry. Bonds .....	50,160.00
Interest from Toronto, Hamilton & Buffalo Ry. Bonds .....	10,840.00
Interest from Kingston & Pembroke Ry. Bonds .....	8,565.00
Interest from Dominion Government Bonds .....	182,500.00
Interest from Ontario Government Bonds .....	48,000.00
Interest from British Consols .....	114,569.44
Interest from Montreal & Atlantic Ry. Bonds, and on other Securities .....	552,298.89
Interest from Berlin, Waterloo, Wellesley & Lake Huron Ry. Bonds .....	17,040.00
Dividend on St. John Bridge & Ry. Extension Co. Stock .....	75,000.00
Dividends on Dominion Express Co. Stock .....	240,000.00
Dividends on Minneapolis, St. Paul & S.S.M. Ry. Common Stock .....	890,645.00
Dividends on Minneapolis, St. Paul & S.S.M. Ry. Preferred Stock .....	445,326.00
Dividends on West Kootenay Power & Light Co. Common Stock .....	33,000.00
Dividends on West Kootenay Power & Light Co. Preferred Stock .....	3,850.00
Dividends on Toronto, Hamilton & Buffalo Ry. Stock .....	164,246.00
Net Revenue from Company's Coal Mines .....	305,237.93
	\$9,058,941.93

Less—Payments to Shareholders in dividends:  
October 1st, 1912, January 2nd, 1913, April 1st, 1913, and June 30th, 1913 .....

From this a dividend has been declared, payable October 1st, 1913 .....

2. The working expenses for the year amounted to 66.82 per cent. of the gross earnings, and the net earnings to 33.18 per cent. as compared with 64.89 and 35.11 per cent., respectively, in 1912.

3. Four per cent. Consolidated Debenture Stock to the amount of £1,938,394 was created and sold, and of the proceeds the sum of £1,051,619 was applied to the construction of authorized branch lines, and £886,775 was devoted to the acquisition of the bonds of other Railway Companies whose lines constitute a portion of your system, the interest on which had, with your sanction, been guaranteed by your Company.

4. Four per cent. Preference Stock to the amount of £1,569,091 was created and sold, the proceeds being used to meet capital expenditures that had your previous sanction.

5. Your guarantee of interest was endorsed on Four per cent. Consolidated Bonds of the Minneapolis, St. Paul and Sault Ste. Marie Railway Company to the amount of \$2,623,000, issued and sold to cover the cost of 131.15 miles of railway added to that Company's system.

6. During the year 474,798 acres of agricultural land were sold for \$7,487,268, being an average of \$15.77 per acre. Included in this area there were 7,944 acres of irrigated land which brought \$48.88 per acre, so that the average price of the balance was \$15.20 per acre.

7. Shares of ordinary Capital Stock to the amount of \$2,000,000.00, being the difference between the Capital Stock outstanding and the amount authorized by the shareholders October 7th, 1908, were sold in the market early in the year and realized a premium of \$2,860,821.80, which will be used for additions and improvements to your property.

8. In pursuance of your policy of building and extending branch lines in Western Canada to provide present and incoming settlers with transportation facilities, a line is projected from a point near Swift Current, on your

main line in Saskatchewan, in a north-westerly direction to cross your Lacombe branch at or about Coronation, and eventually to reach Sedgewick, a station on your line between Saskatoon and Edmonton, a total distance of 290 miles. The first 115 miles of this line should be constructed without delay, and the balance in stretches as circumstances may seem to warrant; two other lines, one of which will run north-easterly from Bassano, on your main line in Alberta, to a connection with the Swift Current line, a distance of 118 miles, and the other from Gleichen to Shepard a distance of 10 miles, should be built within the next year. These lines will serve important agricultural districts north and south of your main line and will answer all the purposes of a second track between the points mentioned for some years to come. The Weyburn branch, running south of, and parallel to, your main line in Saskatchewan and Alberta, to a connection with your Alberta Railway south of Lethbridge, a total distance of 436 miles, of which 196 miles have been constructed, or are in process of construction, under your authority, should be further extended year by year until completed. Branch lines from Gimli, Manitoba, in a northerly direction for a distance of 26 miles, and from Snowflake, Manitoba, in a westerly direction, a distance of 9 miles, and an extension of the Suffield branch in Saskatchewan, 27 miles, will be of substantial service to settlers in these respective districts.

Your Directors will ask you to sanction the construction of such part of this mileage as you have not already authorized, and the issue, from time to time, of the requisite 4% Consolidated Debenture Stock to meet the expenditure.

9. Among the important additions and improvements now in process of execution are, 29 miles of second track between Islington and Guelph Junction, on the Ontario Division, to cost \$750,000; 133 miles of additional second track between Sudbury and Port Arthur, on the Lake Superior Division, to cost \$5,300,000; 178 miles of additional second track between Brandon and Calgary, to cost approximately \$5,000,000; 18 miles of second track and grade improvements, including a double track tunnel, five miles in length, between Six Mile Creek and the "Loop," near the summit of the Selkirk Mountains, at a cost, without electrification, of about \$8,000,000; 139 miles of second track between Revelstoke and Vancouver, in stretches where it will give the most immediate relief, to cost \$6,350,000.

When this work is finished and the new lines between Regina and Shepard, to which reference has already been made, are constructed, there will be 200 miles of double track between Sudbury and Port Arthur, leaving 352 miles to be provided in the future; between Port Arthur and Calgary there will be 1095 miles of double track, leaving gaps aggregating only 165 miles, and between Calgary and Vancouver 158 miles of double track, leaving 488 miles to be built hereafter.

A second track on such a large portion of your main line between Sudbury and the Pacific Coast will relieve the congestion that has prevailed from time to time and will enable you to handle your traffic more expeditiously and economically, and the construction of the long tunnel, between Six Mile Creek and the "Loop," will eliminate four and one-half miles of snow-sheds that it would be necessary to reconstruct at very great expense if the present location of the railway through that section were adhered to. It is not the intention of your Directors to proceed with the second track in the more difficult sections along the Thompson and Fraser Rivers until your Kettle Valley Line is ready for traffic between Midway and Hope, in 1915, so that you may have an alternative route available between Medicine Hat and Vancouver via the Crow's Nest Pass if anything unforeseen should occur during the prosecution of the double track work to obstruct traffic on the main line.

10. You will be asked to approve the purchase of two intermediate steamships for the Atlantic trade, 500 feet long, 64 feet beam, 11,600 gross tonnage, 15 knots speed, to cost approximately \$300,000 each, and two steamships for the Pacific Coast service, 395 feet long, 54 feet beam, capable of making 22½ knots per hour at sea, and to cost approximately \$200,000 each.

The two Atlantic steamships are urgently required for your second and third class passengers and freight traffic between European ports and Canada, and the two fast passenger steamers for the Pacific Coast will further improve the excellent service that you are now providing for the large and growing passenger business between Vancouver, Victoria and other ports on the Pacific Coast.

11. When the last issue and sale of ordinary capital stock was authorized by you, a portion of the proceeds of the sale was directed to be applied to the retirement of the outstanding five per cent. First Mortgage Bonds of the Company that mature in 1915, and, therefore, your Directors deemed it desirable to give notice to the holders in May last that the Company would receive and pay for any of the Bonds that might be surrendered before the end of the fiscal year. Pursuant to this notice Bonds to the amount of \$4,234,700, or \$20,608,873.33, were delivered and paid for. These, with the Bonds that the Company had previously acquired, make a total of \$4,487,900, or \$21,841,113.33, that have been retired and cancelled, leaving outstanding Bonds to the amount of \$2,703,600, or \$13,157,520.00, to be redeemed and cancelled as opportunity offers.

12. For the convenience of those desiring to make transfers in Montreal of shares of your ordinary capital stock, the Bank of Montreal has been appointed Registrar and the Royal Trust Company has been appointed Transfer Agent for the Montreal Register, and a by-law giving effect to the appointments will be submitted for your consideration and approval.

13. It will be observed that the mileage covered by the statement of gross earnings and working expenses has increased from 10,983 miles in 1912 to 11,602 miles in this fiscal year. The business of a number of these new lines will naturally add but little to your gross income for a time while traffic is being developed, but meantime their maintenance and operation have a marked effect on the working expenses. This, coupled with more liberal expenditure for maintenance of way and of equipment and advances in the wage scale in some branches of the service, will account, in a large measure, for the abnormal increase in your working expenses over the previous year.

14. The item "Railway and Equipment" in the balance sheet is \$69,491,729.27 more than it was in 1912, after applying upwards of \$10,000,000 from surplus account. Of this amount \$30,137,885.86 represents the cost of additional rolling stock, \$9,113,050.21 the expenditure for the construction of branch lines, \$36,809,675.82 for additions and improvements to your property, and \$3,126,347.32 for additional shops and machinery over the whole system.

15. The undermentioned Directors will retire from office at the approaching Annual Meeting. They are eligible for re-election:—

Mr. David McNicoll  
Mr. Charles R. Hosmer  
Hon. Robert Mackay  
Hon. James Dunsmuir.

For the Directors,

F. G. SNAUGHNESS,  
President.

MONTREAL, August 11th, 1913.

CANADIAN PACIFIC RAILWAY COMPANY. CONDENSED BALANCE SHEET, JUNE 30, 1913.

RAILWAY AND EQUIPMENT.....	\$452,320,780.60	CAPITAL STOCK .....	\$200,000,000.00
OCEAN, LAKE AND RIVER STEAMSHIPS.....	23,049,283.21	PAYMENTS ON SUBSCRIPTION TO NEW ISSUE	
ACQUIRED SECURITIES (COST):		CAPITAL STOCK (\$60,000,000.00 @ 175)...	63,451,667.50
Exhibit "A" .....	100,207,933.88	FOUR PER CENT PREFERENCE STOCK.....	74,331,339.79
PROPERTIES HELD IN TRUST FOR THE COM- PANY .....	4,386,260.00	FOUR PER CENT CONSOLIDATED DEBENTURE STOCK .....	163,257,224.32
DEFERRED PAYMENTS ON LAND AND TOWN SITE SALES .....	44,499,115.78	MORTGAGE BONDS:	
ADVANCES TO LINES UNDER CONSTRUCTION..	13,750,205.47	First Mortgage, 5 per cent.....	\$34,998,633.33
ADVANCES AND INVESTMENTS.....	12,072,811.65	Less amount redeemed and cancelled.....	21,841,113.33
MATERIAL AND SUPPLIES ON HAND.....	18,628,206.99		13,157,520.00
CURRENT ASSETS:		Algoma Branch, 1st Mortgage.....	3,650,000.00
Agents and Conductors Balances.....	\$4,118,739.47	CURRENT LIABILITIES:	
Net Traffic Balances .....	120,713.25	Audited Vouchers .....	14,785,322.70
Miscellaneous Accounts Receivable.....	7,013,831.74	Pay Rolls .....	6,549,901.24
TEMPORARILY INVESTED IN GOVERNMENT SE- CURITIES .....	11,253,284.46	Miscellaneous Accounts Payable.....	9,176,078.79
CASH ON HAND.....	30,274,848.30	INTEREST ON FUNDED DEBT AND RENTAL OF LEASED LINES:	
	\$720,531,465.20	Coupons due July 1st, 1913, and including Coupons overdue not presented.....	1,208,016.17
		Accrued Fixed Charges.....	183,785.05

NOTE.—In addition to above assets, the Company owns 6,287,250 acres of land in Manitoba, Saskatchewan and Alberta (average sales past year \$15.77 per acre), and 1,697,994 acres in British Columbia.

AUDITORS' CERTIFICATE.

We have examined the Books and Records of the Canadian Pacific Railway Co. for the fiscal year ending June 30th, 1913, and having compared the annexed Balance Sheet and Income Account therewith, we certify that, in our opinion, the Balance Sheet is properly drawn up so as to show the true financial position of the Company at that date, and that the relative Income Account for the year is correct.  
Montreal, August 8th, 1913.

PRICE, WATERHOUSE & CO.,  
Chartered Accountants (England).

I. G. OGDEN,  
Vice-President.

FIXED CHARGES FOR YEAR ENDED JUNE 30TH, 1913.

£7,191,500	1st Mortgage Bonds 5% due July 1st, 1915	\$ 1,749,931.66
£ 200,000	St. Lawrence & Ottawa Ry. 4% 1st Mortgage Bonds	38,933.34
\$2,544,000	Man. S. West. Colzn. Ry. 1st Mortgage 5% Bonds due June 1st, 1934	127,200.00
	Toronto, Grey & Bruce Ry. Rental	140,000.00
£4,007,381 15 5	Ontario & Quebec Ry. Debenture Stock 5%	975,129.56
\$2,000,000	Ontario & Quebec Ry. Ordinary Stock 6%	120,000.00
£1,330,000	Atlantic & North West Ry. 1st Mortgage Bonds due January 1st, 1937	323,633.34
£ 750,000	Algoma Branch 5% 1st Mortgage Bonds, due July 1st 1937	182,500.00
\$ 500,000	New Brunswick Southern Railway 1st Mortgage Bonds, 3%	15,000.00
\$ 500,000	Lindsay, Bobcaygeon & Pontypool Ry. 1st Mortgage Bonds, 4%	20,000.00
£ 256,800	Shuswap & Okanagan Ry. 1st Mortgage Bonds, 4%	49,990.40
	Rental, Calgary & Edmonton Ry.	218,357.60
	Rental, Farnham to Brigham Jct.	1,400.00
	Rental, Mattawamkeag to Vanceboro	23,800.00
	Rental, New Brunswick Ry. System	372,829.74
	Rental, Terminals at Toronto	24,459.56
	Rental, Terminals at Hamilton	36,817.60
	Rental, Hamilton Jct. to Toronto	42,191.12
	Rental, St. Stephen & Milltown Ry.	2,050.00
	Rental, Joliette & Brandon Ry.	5,000.00
	Rental, Lachine Canal Branch	939.96
	Interest on Montreal & Western Ry.	14,733.42
	Interest on Equipment Obligations	54,266.66

4% CONSOLIDATED DEBENTURE STOCK.

£32,225,428	Interest from July 1st, 1912	\$6,273,216.64
£ 739,434	Interest from Jan. 1st, 1913	71,971.55
£ 581,143	Interest from July 1st, 1913	

Less received from subsidy Northern Colonization Railway .....	8,000.00	6,337,188.19
		\$10,876,352.15

EXHIBIT "C"

DETAILS OF BALANCE SHEET ITEM.

LANDS AND TOWNSITES.		
14,134,804 acres and Townsites sold, amounting to....	\$105,283,167.78	
6,793,014 acres disposed of to the Dominion Government in 1886 .....	10,189,521.00	

Less:—Expenses, Cultivation rebate and 10% on Land Grant Bonds retired and cancelled.....	12,462,331.77	
		\$103,010,357.01

ADD:—		
Proceeds Manitoba So. West. Col. Ry. Land Sales....	\$3,038,497.53	
Proceeds Great North West. Cent. Ry. Land Sales....	1,001,815.61	
Proceeds Manitoba & North Western Ry. Land Sales..	65,535.86	
Proceeds British Columbia Land Sales.....	2,963,987.53	
Proceeds Esquimalt & Nanaimo Ry. Land Sales.....	4,116,631.48	

Less:—Cost of lands purchased from Hudson's Bay Company.....	1,396,591.54	
Cost of land acquired with Esquimalt & Nanaimo Ry.....	1,330,000.00	
	2,726,591.54	

DEDUCT:—		
Expenditures on Irrigation.....	11,942,427.29	
		\$99,527,806.19

Amount expended in Construction of Railway and Equipment and deducted from cost of Property.....	36,193,521.00	
		\$63,334,285.19

EXHIBIT "D"

CONSTRUCTION—ACQUIRED AND BRANCH LINES.

Moosejaw N. W. Branch.....	\$ 613,147.07
Craven-Bulyea Branch .....	6,037.40
Virden-McAuley Branch .....	103,274.05
Stonewall Branch Extension .....	94.40
Lauder Branch .....	196,467.44
Weyburn-Lethbridge Branch .....	2,293,337.52
Langdon Branch .....	477.78
Kipp-Aldersyde Branch .....	61,554.62
Bassano-Irricana Branch .....	180,911.75
Regina-Colonsay Branch .....	180,528.82
Estevan-Forward Branch .....	483,201.34
Waldo-Galloway Branch .....	25,352.72
Moosejaw S. W. Branch .....	103,005.72
Wilkie N. W. Branch .....	74,667.92
KerRobert N. E. Branch .....	404,564.95
Wilkie-Anglia Branch .....	97,092.79
Swift Current S. E. Branch .....	138,044.03
Swift Current N. W. Branch .....	1,412,370.58
Boissevain-Lauder Branch .....	106,134.34
Suffield S. W. Branch .....	824,817.64
Three Forks-Bear Lake Branch .....	85,464.23
Gimli-Riverton Branch .....	28,557.66
Bassano E. Branch .....	235,884.44
Snowflake W. Branch .....	8,549.36
Longue Pointe Extension, Montreal .....	1,115,533.45
Surveys of projected lines.....	334,933.75
	\$9,113,050.21

EXHIBIT "E"

DETAILS OF EXPENDITURE ON ADDITIONS AND IMPROVEMENTS FROM JULY 1ST, 1912, TO JUNE 30TH, 1913.

QUEBEC TO BONFIELD:		
Additional Sidings, Buildings, Stations and Yards .....	\$ 157,064.63	
Permanent Bridges and Improvements of Line	239,535.34	
Right of Way .....	550.00	
		\$ 397,149.97
MONTREAL TERMINALS .....	1,970,536.98	
Windsor St. Station Extension.....	827,405.66	
Double Track Bridge over St. Lawrence River	306,396.01	
BONFIELD TO PORT ARTHUR:		
Additional Sidings, Buildings, Stations and Yards .....	625,022.79	
Permanent Bridges and Improvements of Line	365,554.08	
Double Tracking .....	2,018,997.64	
Right of Way.....	6,051.04	
		3,015,625.55
PORT ARTHUR TO FIELD:		
Additional Sidings, Buildings, Stations and Yards .....	1,161,046.76	
Permanent Bridges and Improvements of Line	797,487.76	
Winnipeg Station and Hotel.....	67,776.36	
Winnipeg Terminals .....	259,835.02	
Winnipeg New Elevator.....	347,252.23	
East Winnipeg Yard.....	2,075,355.21	
Fort William Terminals, including Coaling Plant .....	3,551,126.15	
Double Tracking .....	2,301,743.64	
Right of Way .....	7,490.08	
Calgary Hotel .....	1,085,113.11	
		11,639,246.16
FIELD TO VANCOUVER:		
Additional Sidings, Buildings, Stations and Yards .....	327,116.37	
Permanent Bridges and Improvements of Line	584,592.52	
Vancouver Terminals .....	1,302,394.59	
Double Tracking .....	1,787,230.14	
Right of Way .....	783.88	
		4,002,117.50
Banff Springs Hotel Addition.....	1,206,875.92	
Chateau Lake Louise.....	940,318.85	
Empress Hotel, Victoria.....	599,225.75	
Hotel Vancouver .....	660,584.34	
Total Main Line.....		\$25,565,482.69

BRANCH LINES:

South Western Branch.....	\$ 5,537.49
Stonewall Branch.....	3,470.57
Selkirk Branch.....	6,816.88
Emerson Branch.....	8,870.42
Nakusp and Slocan Branch.....	416.13
Revelstoke and Arrow Lake Branch.....	4,558.66
Snowflake Branch.....Cr.	7.55
Waskada Branch.....	1.75
St. Lin Branch.....	231.16
Lake Temiskaming Branch.....	26,282.49
MacGregor Branch.....	765.72
Mission Branch.....	16,796.02
Arcoia-Regina Branch.....	84,674.64
North Star Branch.....Cr.	155.60
Lac du Bonnet Branch.....	90.88
Wolsley-Reston Branch.....	1,119.26
Lachine Canal Branch.....	5,621.36
Toronto-Sudbury Line.....	346,758.11
Pleasant Hills Branch.....	225,357.47

SOURIS BRANCH:

Additional Sidings, Buildings, Stations and Yards.....	192,368.81
Permanent Bridges and Improvements of Line.....	202,488.48
Right of Way.....	334.65

ALGOMA BRANCH:

Additional Sidings, Buildings, Stations and Yards.....	66,257.21
Permanent Bridges and Improvements of Line.....	33,671.22
Grade Reduction.....	171,380.04

CROWS NEST PASS BRANCH:

Additional Sidings, Buildings, Stations and Yards.....	\$ 47,297.56
Permanent Bridges and Improvements of Line.....	198,388.50
Right of Way.....	558.78
	246,244.84

CROWS NEST PASS BRANCH:

McLeod-Lethbridge deviation.....	403.35
----------------------------------	--------

BRITISH COLUMBIA SOUTHERN RY.:

Additional Sidings, Buildings, Stations and Yards.....	21,040.68
Permanent Bridges and Improvements of Line.....	26,312.84
Right of Way.....	887.85
Balfour Extension.....	4,293.29
Yahk Branch.....	773.97
	53,308.63

Telegraph Extensions and Additions.....	1,703,663.09
Office Building, Toronto.....	269,231.02
Office Building, Edmonton.....	429,827.73
Office Building, Saskatoon.....	229,417.35
Office Building, Hamilton.....	184,711.15
Rented and Temporary Sidings.....	112,980.05
	245,673.67
Total Main Line and Branches.....	\$28,740,986.75

STATEMENT OF EARNINGS FOR THE YEAR ENDED JUNE 30TH, 1913.

From Passengers.....	\$ 35,545,061.67
" Freight.....	89,655,223.33
" Mails.....	921,682.92
" Sleeping Cars, Express, Telegraph and Miscellaneous.....	13,273,732.06
Total.....	\$139,395,699.98

STATEMENT OF WORKING EXPENSES FOR THE YEAR ENDED JUNE 30TH, 1913.

Transportation Expenses.....	\$46,074,299.26
Maintenance of Way and Structures.....	18,498,741.05
Maintenance of Equipment.....	17,198,573.38
Traffic Expenses.....	3,376,980.85
Parlor and Sleeping Car Expenses.....	1,241,700.07
Expenses of Lake and River Steamers.....	1,113,808.10
General Expenses.....	3,953,769.74
Commercial Telegraph.....	1,691,953.38
Total.....	\$93,149,825.83

STATEMENT OF SURPLUS INCOME ACCOUNT, JUNE 30TH, 1913.

Balance at June 30th, 1912.....	\$72,885,966.34
Net earnings of Railway and Steamship Lines.....	\$35,490,085.03
Special Income.....	6,598,151.33
(as per statements)	42,088,236.36
	114,974,202.70
Less: Dividends on Preference Stock, paid October 1st, 1912, and April 1st, 1913.....	2,807,288.47
And dividends on Ordinary Stock, paid October 1st, 1912, January 2nd, 1913, April 1st, 1913, and June 30th, 1913.....	19,000,000.00
And interest on instalments on New Stock Subscriptions, paid October 15th, 1912....	569,813.87
	22,377,102.34
	92,597,100.36
Amount applied on account of Additions and Improvements.....	15,000,000.00
Total Surplus Income, June 30th, 1913.....	\$77,597,100.36
From this there have been declared the dividends on Preference and Ordinary Stock, payable October 1st, 1913, amounting to.....	6,486,626.79

APPROPRIATION FOR ADDITIONS AND IMPROVEMENTS.

Balance at June 30th, 1912.....	\$ 3,535,712.14
Premium on issue \$18,000,000.00 and on sale of \$2,000,000.00 Ordinary Stock.....	11,750,647.81
Amount appropriated as authorized at Shareholders Meeting, October, 1912.....	15,000,000.00
	30,286,359.95
Less: Expended during year included in Exhibits "E" and "F" and for acquisition and development of the Company's Coal Mine Property.....	12,373,363.54
Amount unexpended.....	\$17,912,996.41

TRAIN TRAFFIC STATISTICS—FOR TWELVE MONTHS ENDED JUNE 30TH, 1913 AND 1912.

EARNINGS OF LAKE AND RIVER STEAMERS NOT INCLUDED IN THIS STATEMENT.

	Year ended June 30th, 1913.	Year ended June 30th, 1912.	Increase or Decrease. Amount or number.	Per Cent.
<b>TRAIN MILEAGE.</b>				
Passenger trains.....	22,333,592	19,591,027	2,742,565	14.00
Freight.....	27,611,103	25,638,692	1,972,411	7.69
Mixed.....	1,888,095	1,727,792	160,303	9.28
Total trains.....	51,832,790	46,957,511	4,875,279	10.38

CAR MILEAGE.

<b>PASSENGER.</b>				
Coaches and P. D. and S. cars.....	110,347,064	100,088,130	10,258,934	10.25
Combination cars.....	3,206,048	2,917,523	288,525	9.89
Baggage, Mail and Express cars.....	46,677,110	42,678,970	3,998,140	9.37
Total Passenger cars.....	160,230,222	145,684,623	14,545,599	9.98
<b>FREIGHT.</b>				
Loaded.....	581,397,285	556,244,798	25,152,487	4.52
Empty.....	165,627,992	140,210,160	25,417,812	18.13
Caboose.....	30,617,975	27,871,524	2,746,451	9.85
Total Freight cars.....	777,643,252	724,326,502	53,316,750	7.36
Passenger cars per Traffic Train Mile.....	6.62	6.83	.21	3.07
Freight cars per Traffic Train mile.....	26.36	26.47	.11	.42

PASSENGER TRAFFIC.

Passengers carried (earning revenue).....	15,298,048	13,593,569	1,704,479	12.54
Passengers carried (earning revenue) one mile.....	1,766,982,013	1,610,251,856	156,730,157	9.74
Average journey per passenger.....miles	115.51	118.46	2.95	2.49
Average amount received per passenger.....\$	2.28	2.30	.02	.87
Average number of passengers per train mile.....	1.97	1.94	.03	1.55
Average number of passengers per car mile.....	72.95	75.53	2.58	3.42
Revenue from passengers per passenger car mile, cts.....	30.72	30.31	.41	1.35
Total passenger train earnings per train mile...\$	1.75	1.75	...	....
Total passenger train earnings per mile of road...\$	3,724.92	3,471.85	253.07	7.29

FREIGHT TRAFFIC.

Tons of revenue freight carried one mile.....	11,242,690,998	10,180,782,322	1,061,908,676	10.43
Tons of non-rev. freight carried one mile.....	1,743,928,157	1,615,529,852	128,398,305	7.95
Total tons (all classes) frt. carried one mile.....	12,986,619,155	11,796,312,174	1,190,306,981	10.09
Tons of revenue freight carried one mile per mile of road.....	989,081	945,519	43,562	4.61
Tons of non-rev. freight carried one mile per mile of road.....	153,423	150,039	3,384	2.26
Total tons (all classes) freight carried one mile per mile of road.....	1,142,504	1,095,558	46,946	4.29
Average amount received per ton per mile of revenue freight, cts.....	0.784	0.772	.012	1.55
Average No. of tons of revenue freight per train mile.....	381.12	372.02	9.10	2.45
Average No. of tons of non-rev. freight per train mile.....	59.12	59.03	.09	.15
Average No. of tons of (all classes) freight per train mile.....	440.24	431.05	9.19	2.13
Average No. of tons of revenue freight per loaded car mile.....	19.34	18.30	1.04	5.68
Average No. of tons of non-rev. freight per loaded car mile.....	3.00	2.91	.09	3.09
Average No. of tons of (all classes) freight per loaded car mile.....	22.34	21.21	1.13	5.33
Freight train earnings per loaded car mile, cts.....	15.15	14.13	1.02	7.22
Freight train earnings per train mile...\$	2.99	2.87	.12	4.18
Freight train earnings per mile of road...\$	7,750.78	7,298.71	452.07	6.19

# Railway Age Gazette

PUBLISHED EVERY FRIDAY AND DAILY EIGHT TIMES IN JUNE, BY THE  
SIMMONS-BOARDMAN PUBLISHING COMPANY,  
WOOLWORTH BUILDING, NEW YORK.

CHICAGO: Transportation Bldg. CLEVELAND: Citizens' Bldg.  
LONDON: Queen Anne's Chambers, Westminster.

E. A. SIMMONS, *President.*  
L. B. SHERMAN, *Vice-President.* HENRY LEE, *Sec'y & Treas.*  
The address of the company is the address of the officers.

EDITORS.

SAMUEL O. DUNN, *Editor.*  
ROY V. WRIGHT, *Managing Editor.*  
W. E. HOOPER  
B. B. ADAMS  
E. T. HOWSON  
H. H. SIMMONS  
H. F. LANE  
E. A. AVERILL  
R. E. THAYER  
A. C. LOUDON  
E. S. FAUST  
F. W. KRARGER  
A. D. CLOUD  
GEORGE L. FOWLER

Subscriptions, including 52 regular weekly issues and special daily editions published from time to time in New York, or in places other than New York, payable in advance and postage free:

United States and Mexico.....	\$5.00
Canada .....	6.00
Foreign Countries (excepting daily editions).....	8.00
Single Copies .....	15 cents each

Engineering and Maintenance of Way Edition and four Maintenance of Way Convention Daily issues, North America, \$1.00; foreign, \$2.00.

Entered at the Post Office at New York, N. Y., as mail matter of the second class.

WE GUARANTEE, that of this issue 8,150 copies were printed; that of those 8,150 copies, 6,698 were mailed to regular paid subscribers and 349 were provided for counter and news companies' sales; that the total copies printed this year to date were 318,559—an average of 8,610 copies a week.

VOLUME 55. SEPTEMBER 12, 1913. NUMBER 11.

## CONTENTS

EDITORIAL:

Editorial Notes .....	441
The North Haven Collision.....	442
Banking Influence on Railroad Management.....	443
Fundamentals of Valuation of Public Utilities.....	444

LETTERS TO THE EDITOR:

Engine House Pay .....	446
------------------------	-----

MISCELLANEOUS:

*Mountain Railway Electrification; by Allen H. Babcock.....	447
A Plea Against Hasty Legislation.....	449
Original Cost Versus Replacement Cost as a Basis for Rate Regulation; by Raymond V. Hayes.....	450
*Construction of the Portland, Eugene & Eastern.....	453
*Locomotive Tractive Effort; by H. A. Houston.....	455
Interpretation of the Rules of Interchange.....	457
Comparative Summary of Freight Cars in Service.....	458
The North Haven Collision.....	461
*Combination Brass, Iron and Steel Foundry.....	467
Foreign Railway Notes .....	446, 454, 458

GENERAL NEWS SECTION..... 469

\*Illustrated.

THE government-owned Intercolonial Railway of Canada is hardly a model either in economies of operation, earning power or standards of upkeep for American railroads more favorably situated; but there is one lesson which American railroad officers having to do with the training of employees might well take from the Intercolonial. No matter how infrequent the service, how slow the trains, what the delay, one experiences generally, when traveling on the Intercolonial, numerous instances of little courtesies by employees which take the edge off of annoyance and, one sometimes suspects, actually go further toward making a satisfied patron than would the expenditure of many hundreds of thousands of dollars for better roadbed and equipment. The Intercolonial has succeeded in creating a public

opinion among its own employees which is distinctly adverse to the smart or surly rejoinder of a trainman to even a silly question by a passenger. The question of whether or not the train will be on time is as important a subject of speculation when traveling as the weather is in daily life. Why should not trainmen be taught to give a courteous answer to this continually recurring question from passengers, and yet this is the one question which almost never receives a courteous, intelligent answer. It may be that the Canadians are naturally more polite than the same classes in the United States. If so, there is all the more reason why pains should be taken by American railroad officers to cultivate a spirit of politeness in those of their forces who come in contact with railroad patrons.

MR. BABCOCK'S discussion of the advantages of the electrification of steam railroads having heavy grades, with special reference to Tehachapi Pass on the Southern Pacific, which is abstracted on another page in this issue, is radically different in tone from many of the previous papers on electrification. Most of these have advocated the adoption of electric power on roads now operated by steam. Mr. Babcock is a practical steam railroad man who has been forced to go into the problems of electrification very thoroughly within recent years. The electrification of the mountain districts of the Southern Pacific must be justified, if at all, by increased economy in operation rather than by results such as increased safety, the elimination of smoke, the development of passenger traffic, etc., which have been the ends sought in practically all the electrification of steam roads, which has been done up to date. The problem on the Southern Pacific has been the subject of very animated discussions for several years. The contrast between this and previous papers brings out sharply the failure of many electrical engineers to understand steam road problems and to adjust their dissensions and plans to these conditions. The papers read before the American Institute of Electrical Engineers and other associations have been devoted more to technical details than to the larger problems of the practical application of electricity to steam road operation. Electrical engineers have complained that steam railway men refuse to adjust their methods of operation to secure the best results from electrification. Many of them have failed to realize that it will be necessary, at first at least, for them to adapt electrification to existing steam road practice. If the results then gained are measurably satisfactory, steam railroad men may become willing to revise their methods to secure yet greater advantages from electrification. Likewise, comparisons between steam and electric operation should be based upon the best types of steam locomotives, in which connection James J. Hill has said that the development of the Mallet locomotive has set back electrification at least 10 years. The paper by Mr. Babcock is timely in view of the widespread interest in the subject of electrification of trunk line railroads, and should stimulate the collection of data regarding the economies actually attained under such operation. Such material has not been available to any considerable extent up to the present time.

THE case of Engineman Miller, responsible for the wreck at signal No. 23 at North Haven, Conn., ought to be highly instructive to those editors who theorize so confidently that financial mismanagement has been the cause of the train accidents on the New Haven road, as well as to railroad officers who are content to let their own reputation as disciplinarians rest on the slender support of the doctrine that when a man's own life is at stake he will surely be on his guard. Miller is in the prime of life, and of good habits; has had years of experience and was on his regular run. He had 12 hours off duty the day before he began this night run. He seems to have a rather nervous temperament, but the general manager is quoted as saying that, in spite of the mistake in this case, he would like more such runners. Miller had a clear record of two years six months, but had one or two demerits in his years as

runner before that. He had had to be vigilant for 50 miles on this trip on account of the fog, and there is no suspicion that he was asleep. He was perfectly acquainted with the road and knew that he was approaching a stop signal, and it seems to be quite certain that he simply "lost his bearings" in the fog, which means, in other words, miscalculating distance, or allowing the mind to wander for a few seconds, sufficiently to forget all about distance. The line is straight; he had gone less than a mile and a half from the last preceding signal (No. 25) which both he and his fireman say they saw (and called). Ordinary fields lie on both sides of the line with no cuts, fills, trees, buildings or other landmarks, except a gravel pit, not far from signal No. 25. The gravel pit seems to have been the runner's one landmark, and, for some unexplained reason, he did not take advantage of it. No one who was present at the hearings treats his story as other than honest. It is possible that having only 85.7 per cent. of the cars braked was an element in his miscalculation; or that with the 125-ton engine he was not so fully the master of the situation as he would have been on an engine with which he had had longer experience; but he offered nothing of this kind as an excuse or defence. He had run this engine on this train two months. It may be that he was in the habit of thinking that to stop 100 ft. beyond a block signal was safe enough—other witnesses testified that such over running happened rather frequently—but against this supposition we have the fact of his good record and his apparently consistent purpose to maintain it. Errors exactly like Miller's occur, probably, every month, perhaps oftener, on roads of which the financial management is not only not blamed, but is praised. No one has accused even Mr. Mellen of denying his superintendents any facilities or any money that they needed or wanted for educating their enginemen. Clearly the remedy for this kind of error must be looked for somewhere else than in an investigation of "Wall Street."

**E**NGINEMAN MILLER had been doing two men's work for a week prior to the wreck, and this fact is the subject of innumerable "scare-heads" in the daily papers, both yellow and white. But the fact is that he did this while still being on duty only 10 hours a day; five hours 17 minutes, plus delays, on the road, and four hours 43 minutes at terminals, including a rest of three hours 35 minutes, at Springfield. If he had been doing only his own work he would have been on duty about 10 hours every other day. The news editors who shout "overwork" ought to say specifically whether they consider these hours excessive; and then they will do well to ask a few representative enginemen how strongly they object, when well paid, to working regularly nine hours out of every 24. There is no claim that Miller was either tired or sleepy, and this question of hours has to do with the general practice rather than with the cause of this particular collision; but it is to be noted that if there was any trouble anywhere it was in the way that Miller spent his time off duty. His day was spent as follows, the two central columns representing the run of his engine and the two shorter columns his dead-head trips from and to his home.\*

Miles.	Read down.	Read up.	Read down.	Read up.
Springfield 0	.....	Ar. 12:35 a.m.	Lv. 4:20 a.m.	.....
Home.....	Lv. 4:30 p.m.	.....	.....	Ar. 11:00 a.m.
New Haven 62	6:14 p.m.	10:52 p.m.	5:45 a.m.	10:08 a.m.
Stamford. 102	Ar. 7:12 p.m.	Lv. 9:56 p.m.	Ar. 6:56 a.m.	Lv. 9:09 a.m.

He lived at Montowese, on the Air Line division, four miles from New Haven. How he got from there to New Haven, whether by freight train or street car, does not appear (the time table shows no passenger trains at the hours named). Being off duty over 14 hours each day, even when doing two men's work, he yet had only 5 hours 30 minutes for uninter-

\*The record of Miller's trips from August 25 to September 2 inclusive, shows that he arrived at Springfield on time five nights and on others from six to ten minutes late, except on the last trip before the wreck, when he was 42 minutes late. On the southbound trips he reached Stamford on time one day and on the others considerably late, the greatest delay being 2 hours 31 minutes, on September 1, when he had left Springfield nearly two hours late.

rupted rest, on a bed. He could sleep 8 or 9 hours—provided his nerves were calm enough—but he had to do it in three places. No one can say that this work-day schedule actually had the effect of making Miller unfit to run; but we lay it before the reader because it affords a striking illustration of an objectionable practice which prevails on railways generally. From any high standpoint, either business or hygienic, it should be held to be not only objectionable but absolutely bad. To apportion the blame for this would not be easy. Both the railroads and the brotherhoods have a responsibility in the premises. It is a grave responsibility. The blame for a wreck may not for years be found definitely chargeable to this bad practice, but everybody can see its badness, nevertheless. In academic discussions we all recognize the value of regular rest; why should we not act as we talk? And Miller's testimony concerning his previous experiences should be read by every one. He took this passenger run, with its very irregular hours—irregular even when he worked only on alternate days—because in the freight service the irregularity was so very much worse.

**THE NORTH HAVEN COLLISION.**

**I**N another column we report quite fully the hearing on the North Haven wreck. So prominent an accident must be fully recorded. But the broad lessons of this are exactly like those of many previous collisions. The New Haven road has, for years, been running fast trains close together in foggy weather without distant signals. This puts a severe strain on the engineman—except on those individuals who have the peculiar temperament and grit needed for such a job—and a good engineman has now broken down under it; passengers are killed and the road pays a great penalty. But the essential public question is just the same that it has been for years. To agree with this the reader only has to recall a half dozen prominent collisions; those at Tyrone, Stamford, Western Springs, Corning, Kinmundy and Batavia; and the derailments at St. Johnsville, Monmouth Junction and Westport.\* These and many more like them have, with a frequency which it would seem ought to be sufficient, reminded everybody of the delicate, important and vital functions which have to be performed by the engineman. The superiority of steel cars over wooden is an important matter; and the question of audible signals and automatic stops also must be kept in mind; but the great and immediate question is that of training enginemen to be vigilant. This question is immediate because every superintendent knows that not all of his enginemen measure up so near to 100 per cent. as he would like; and it is great because improvement of the enginemen is the only remedy that can be applied without delay. To introduce mechanical adjuncts takes much time, as well as money. To reduce speed or to make arbitrary rules requiring trains to be frequently stopped, as a safety measure, is an injustice to the public, so long as any other resource is available.

As for the New Haven road, the facts given in our report are their own commentary. The lack of distant signals is not the only lack. Many weaknesses in discipline were shown, but those which were most emphasized by the government and by the newspapers have but an indirect bearing on this case, or none at all, and their discussion here would only becloud the main issue. The flagging was utterly inefficient, and it goes without saying that where the flagging rule obtains the flagman ought to obey it in the spirit in which it is intended. But block signals and enginemen have got to get along, in some way or other, without

\*Pennsylvania .....Tyrone, Pa. ....July 30, 1913....Rear collision  
 N. Y. N. H. & H....Stamford, Conn. ....June 12, 1913....Rear collision  
 C. B. & O.....Western Springs .....July 14, 1912....Rear collision  
 D. L. & W.....Corning, N. Y. ....July 4, 1912....Rear collision  
 Illinois Central .....Kinmundy, Ill. ....June 22, 1912....Rear collision  
 New York Central...Batavia, N. Y. ....June 13, 1911....Rear collision  
 New York Central...St. Johnsville, N. Y. ....Jan. 25, 1910....Derailment  
 Pennsylvania .....Monmouth Junction.....Nov. 17, 1911....Derailment  
 N. Y. N. H. & H....Westport, Conn. ....Oct. 3, 1912....Derailment

depending in every little irregularity of train movement on the flagman, or else the problem of improving block signals and enginemen must continue to be a pressing one. Officers of the road presented some poor excuses and defenses on the witness stand, and the personal appearance of some of their subordinates was not creditable to those officers who select and promote employees. But a new management is now engaged in a strenuous effort to correct the faults of the past.

The North Haven case is like that at Western Springs, in that there was no distant signal. The new superintendent (following the practice, since the former disasters, of having personal interviews with enginemen) had told Engineman Miller that reducing speed (and losing time) to find signals in fog was not only approved, but required; but Miller made the mistake, notwithstanding. Can it be that his own personal ambition to make time, regardless of the requirements of the company, was the unconscious influence that caused him to disregard the superintendent's admonition? It is not at all unlikely. That habit of mind was of long standing, while the superintendent's proposal was in a sense new. We all know how brakemen—and some conductors—will take risks to do what they deem a creditable job, in spite of orders to avoid those very risks. Fair weather schedules—speeds that cannot be made in fog—will always contain an element of danger; certainly on lines where trains are frequent and fast.

But in every one of the other accidents mentioned above, there were adequate visual signals, home and distant. A distant signal does not cure all kinds of carelessness. Miller, asked if the signal system would be better with distant indications, replied, "Gentlemen, if there had been a distant signal, you would not be here." That thought may be some slight solace to him; but no railroad manager will venture to pin his faith to that alone. Reflection on the circumstances of this and the other cases which have been referred to, and on the fact, brought out at the New Haven hearing, that New Haven enginemen, notwithstanding their good records in past years, break the rules regarding stop signals and neither report the cases themselves nor get found out by their superiors—these things reinforce the lesson that for engine runners only the very highest perfection of discipline is adequate. Miller would grade as a good man, but he had not had much discipline. Road foremen of engines had ridden with him only a very little or none at all. The officers' good opinion of him was based largely on negative knowledge. The eight trainmasters of this division have each several hundred men to look after, and cannot train or even watch, with much effect, the individual employees. The trainmaster has to depend on what assurance he can get that a man has trained himself or has been trained by some associate. To have conductors and enginemen who can be called really trained—trained by a fully competent and approved trainer, the New Haven apparently needs several times as many trainmasters and road foremen as it now has. The new officers tell of large numbers of meetings for instruction, and of lectures, and also personal interviews, but still they deal in generalities, except as to the personal interviews. Perhaps they have not yet found the time, the resources and the men to get any farther; but it is quite evident, from the facts as given out, that for the superintendents of divisions to *know* how efficient and reliable their individual employees are, they would have to employ many more subordinate officers and inspectors than are now available. Is not this quite true of many roads other than the New Haven? And is there any entirely satisfactory way of learning the capabilities of an engineman or a conductor except by seeing him do his work? "Seeing" means, of course, frequent inspections until the employee has reached the point where he can be classed as tried and true.

In the investigations which have been made of the accidents noted above, and of others, the *general* question of discipline and training of enginemen has been left in large measure obscure. Howsoever much was brought out concerning those particular

cases, observers who wondered how many other runners on that road were of equally uncertain quality were obliged to keep on wondering. Neither the government nor any other power has made more than a superficial investigation. Is it not to the advantage of every railway management to let the public know something about this feature of its internal affairs? At all events, it is safe to say that if the superintendent has reasons for not letting the public know how minutely or effectively his men are trained, it is well worth while to examine those reasons very thoroughly, to see if they are sound ones.

In requiring superintendents to get along with too few or too cheap trainmasters or road foremen of engines, the New Haven road is not alone. The need of positive knowledge as contrasted with negative knowledge concerning the capability of employees, is felt in many railway offices. But the North Haven collision emphasizes the importance of one branch of "negative" knowledge, namely, surprise checking. There had been none of this on the New Haven recently, and that which was had in former years was not satisfactory. No one who is well-informed is unmindful of the criticisms of this kind of inspection, and of the alleged unfair and even dangerous things that have been done in its name; but the faults are not incurable, and the fundamental principle not only is just, but should receive the commendation of well-meaning employees. Whatever the difficulties, every railroad superintendent is bound to know all that it is possible to know concerning the work of every one of his enginemen.

#### BANKING INFLUENCE ON RAILROAD MANAGEMENT.

J. P. MORGAN & COMPANY have notified the New York, New Haven & Hartford of their intention to terminate within 90 days the agreement by which the Morgan firm has been the sole banker for the New Haven. Immediate interest, of course, is aroused as to whether this has any important bearing on the position of New Haven security holders. To put it frankly, the question arises as to whether the Morgan withdrawal is due to any belief on the part of the bankers that the New Haven's financial position is unsound. Without having any further information than is afforded from the New Haven's own accounts and from the history of the Morgan firm's relations to its railroad companies, there does not appear to be the slightest ground for believing that the termination of the agreement by the bankers is prompted by any fear of future New Haven financial difficulty. It is quite conceivable that New Haven stockholders may have to face a further reduction in their dividend rates. A recent statement given out by Mr. Elliott clearly suggests such a possibility; but that New Haven debenture and bondholders are in any unprotected position is almost unbelievable.

The official statement given out by the banking firm that its withdrawal was due to a desire to leave the new management under Mr. Elliott free to make whatever new arrangements they saw fit would be probably not only correct in itself, but also comprehensive, if it were amplified by the statement that J. P. Morgan & Co. are sensitive to the criticism that has been leveled against them in connection with the underwriting of the new \$67,000,000 New Haven debentures. In this matter, which is unaffected by the notice of withdrawal, the bankers received a commission of 2½ per cent. for their services as underwriters. On the face of it, this commission does not appear to be excessive. Morgan & Company have always stood behind their roads, even when they were in far worse difficulties than anything that one can see in the New Haven situation. They stood behind the Southern Railway when only a very conscientious as well as a very strong banking house could have done so. They failed to stand behind the Erie at its time of crisis, only because the Erie had nothing which it could pledge, and a conservative banking house can hardly be blamed for refusal to lend money on an entirely unsecured note,

Assuming that this termination of the banking agreement does not portend any possible danger to New Haven security holders, are these security holders going to gain anything by it?

Can the New Haven do its financing any cheaper by shopping elsewhere? There are only a few of the largest banking houses that could possibly undertake the New Haven financing. Kuhn Loeb probably could and might be willing to if the New Haven directors asked it, but the bankers would not themselves seek the business. Lee Higginson, or Kidder Peabody might be able and willing to undertake the financing of the company, or the New Haven directors might decide to sell each issue of securities to the banking house that would pay the highest price at that particular time and for that particular security.

This brings up the question of the effect of bankers' relations with railroad companies in general. Morgan & Company were criticized because members of the firm were on the New Haven board of directors when the directors decided to make the agreement appointing Morgan & Company as sole financial agents; but an agreement between a railroad company and one of the large wholesale banking houses, either expressed or implied, is the rule rather than the exception. It is not known that the Pennsylvania has any agreement with Kuhn, Loeb & Company which would prevent the railroad company from selling its securities wherever it could get the best prices for them; but the simple fact of the matter is that the Pennsylvania does not go about shopping its securities, and probably it does not believe that this is a sound policy. The Goulds and B. F. Yoakum have followed a general policy of shopping the securities of their roads around among any bankers that would give them the best price, and the Gould roads' credit at the present time, and the inability of the Frisco to refund maturing notes are both at least in some part the result of this policy. Strong banking support is as necessary to a railroad company as it is to a merchant doing a very large credit business.

On the other hand, banking influence on railroad management has not always been in the best interests of the best road. The Morgan influence on the management of the Southern Railway, the Erie, the New York Central & Hudson River and the New York, New Haven & Hartford has not been without its undesirable features. If a railroad president holds his position because he is the choice of the road's bankers, there is the risk that his feeling of loyalty to them may, under certain circumstances, affect his judgment when that judgment should be solely guided by his duty to the road's security holders.

This question of the relation of bankers to corporate management is of far-reaching importance. Within recent years public utility corporations and industrial concerns as well as railroads have gone to the private banking houses for tremendous sums of money. Industrial concerns that were built up by individual business men have been incorporated, the individual owner has sold all or a large part of his interest, and the ownership of these corporations has been distributed to the public by the banking and bond houses. To protect themselves and their clients the bankers have retained representation on the board of directors. The boards, therefore, not only of railroad companies but of public utility and of a great number of industrial concerns, contain representatives of banking interests, and it depends very largely on the ability and moral standing of the banking houses as to whether or not this representation shall be an influence for good or for bad.

Banking influence which demands of a railroad, public utility corporation or industrial corporation president that he make a good showing in a particular month or series of months to influence the sale of securities, is unqualifiedly bad. It may be a necessary evil; that usually is the ground on which justification of such action is sought. If the director or directors representing bankers on a railroad board confine their efforts entirely to the legitimate one of protecting the interests of their clients to whom they have sold securities, through an enforcement of conservative views in regard to new financing, exten-

sions, etc., they perform an important and highly desirable function; while the ability of the road to raise new capital in times of bad security markets as well as good, because of the banking interest in the directorate, is a valuable asset to the railroad.

Contrary to popular belief even among generally well informed men, the danger that lies in the domination of a banking house in the board of directors of a railroad company is not that the bankers, as directors of the road, will sell themselves securities at too low a price, but that they will, consciously or unconsciously, exert an influence on the operation of the property which is harmful because either ignorant or narrow. The bankers understand better than any one else the ethics of their own profession. When as railroad directors they pass upon the price at which the company ought to and can sell its securities, they are giving the railroad company the service of experts, and if this price were to be too low, they would be doing a conscious wrong act which they could not conceal from their own associates and one that is condemned utterly and absolutely by the ethics of their profession. There have been bankers who have abused the dual relation created by their being members of the board of directors of a railroad company, but the instances are comparatively rare.

When, however, the banker, sitting on a board of directors, or in talking over the situation with the railroad president whom he has been influential in selecting, urges his views as to the management of the property—of the showing which should be made by arbitrarily cutting down expenses to improve the position of the preferred stock preparatory to an issue of bonds, for instance—there is a very real danger that the best interests of the property will suffer. The remedy for this danger is in the cultivation of a public opinion among bankers, railroad men and educated people that will condemn as unethical this sort of interference and will demand the selection of railroad presidents who will be strong enough in the courage of their own convictions to follow their own judgment even where it differs from banking interests on the board of directors.

#### FUNDAMENTALS OF VALUATION OF PUBLIC UTILITIES.

IN discussion and action regarding matters of great public importance it is wise frequently to get down to fundamentals. Among the questions of public importance to the fundamentals of which it is now expedient to get down is that of valuation of public utilities. The Interstate Commerce Commission has entered on the preliminary work of making a valuation of all common carriers doing an interstate business. The purposes of the valuation are not specifically stated in the legislation providing for it, but they are well known. The main one is to establish a basis for the regulation of rates. An important auxiliary purpose is to establish a basis for the regulation of the issuance of securities. Much is being said and written about the general subject of valuation for these purposes, and especially the former, which shows that some of those doing the talking and writing ignore or do not know the origin, and the history of the development, of the theory of valuation. Yet in order that the subject of valuation may be intelligently discussed, and that valuations may be made which will serve the purposes for which they are intended, it is essential that the origin and growth of the theory, and the principles involved in it, should never be lost sight of.

The seed from which the entire theory of valuation of public utilities and all the valuation projects have sprung up is the principle laid down by the Supreme Court of the United States in the Nebraska rate case in 1898 that "the basis of all calculations as to the reasonableness of rates to be charged by a corporation maintaining a highway under legislative sanction must be the fair value of the property being used by it for the convenience of the public." The court stated in 1910, and in 1911, the same principle in but slightly different language when it said in the San Diego Land and Town case, "what the company is entitled to demand

in order that it may have just compensation is a fair return upon the reasonable value of the property at the time it is being used for the public."

It helps to an understanding of what the court meant to revert to the provisions of the federal Constitution from which the principle stated by it was deduced. The Fourteenth Amendment to the Constitution prohibits any state from taking property without due process of law and from denying to any person within its jurisdiction the equal protection of the laws. The Fifth Amendment prohibits the federal government from taking private property for public use without just compensation. The due process of law and equal protection of the laws which the Fourteenth Amendment requires the states to observe are interpreted to require them, just as the Fifth Amendment specifically requires the nation, to pay just compensation when private property is taken for public use. It is these provisions which protect the property owner, when his property is taken from him in the exercise of the power of eminent domain, from having it taken without payment to him of its fair value. And it is these same provisions which are the real foundation of valuation of public utilities for the regulation of their earnings and rates. The courts have reasoned that while public utilities render a public service their property is as private in its ownership as the farmer's land. Therefore, the public could not condemn and take the property of a public utility, any more than it could the farmer's land, without paying just compensation for it. When the earnings of a public utility are reduced by regulation of its rates its physical property is not actually taken from its owners. But the regulation is by and for the benefit of the public, and if the rates fixed are so low as to deprive the owners of a reasonable return, then, in proportion as the return is reduced below what is reasonable, the value of their property is taken. But to confiscate the value of the property for public use is equivalent to confiscating the property itself. Therefore, it is unconstitutional. In other words, the constitutional provisions and principles which protect the farmer from having his farm taken for public use without just compensation are precisely the same as those which protect the railway from having its rates so regulated as to deprive it of a fair return on the fair value of its property.

Since the purpose of these constitutional provisions is—among other things—to secure to the farmer when his property is taken under the power of eminent domain compensation representing its fair value, and to secure to the railway when its rates are regulated compensation representing a fair return upon the fair value of its property, it would seem to follow that so far as may be practicable fair value should be given the same meaning, and should be arrived at in much the same way, in the one case as in the other. And this apparently is the view taken by the federal courts in the important railway rate cases involving the question of confiscation. When property is taken under the power of eminent domain, the value on which the compensation paid for it must ordinarily be based is its value at the time it is taken. The amount which it has cost its owner may be considered in the endeavor to ascertain its present value; but it is the payment of its present value, and not of what it has cost its possessor, which constitutes just compensation. On the same principle the valuation of a public utility to establish a basis for the regulation of its rates must, it would seem, be based on the present value of its property. That this is the correct legal view certainly seems to be a just inference from language repeatedly used by the federal courts. As already indicated, the origin of the theory of valuation is to be found in the decision of the Supreme Court of the United States in the Nebraska rate case. The opinion of the Circuit Court in this case, which subsequently was sustained by the Supreme Court, was written by Justice Brewer, and it is significant that in this opinion Justice Brewer said: "Now, if the public was seeking to take title to the railroad by condemnation the present value of the property, and not the cost, is that which it

would have to pay. In like manner, it may be argued that when the legislature assumes the right to reduce rates the rates so reduced cannot be adjudged unreasonable if under them there is earned by the railroad company a fair interest on the actual value of the property." And repeatedly in later cases the federal courts have indicated that the underlying principles involved in valuation for the regulation of rates are substantially the same as those involved in valuation for the purpose of taking property under the power of eminent domain.

Within recent years, and especially within recent months, an increasing number of writers has been advocating valuation based chiefly on "original" or "actual" cost. The "actual cost" theory in one form is outlined in the article by Hammond V. Hayes, which is published elsewhere in this issue. Some writers apparently take the view that valuation should be based chiefly or almost entirely on the actual cost of the property. Others think that investors are entitled to a fair return year by year on all that they have invested; and that if, on the average, they have failed to receive a fair return the difference between the amount of return that they should have received and that they have received should be added to their actual investment to make up the total valuation. The "actual cost" theory has a strong attraction for those who have grown to believe that the public as a whole, and not individual members of it, should benefit by the "unearned increment" in land; and there is, of course, a vast amount of this unearned increment in the real property of railways. While the actual cost theory has been skilfully presented, and has been accepted by many persons, it seems open to objections of the most destructive character.

In the first place, originally the present value theory was advocated by those who sought to reduce railway rates, the reason being that at that time the prices of materials and supplies, the wages of labor and the value of land were so depressed that it was assumed that the cost of reproducing the railways then would be less than their original cost had been. It seems most unfair to advocate the reproduction theory when its adoption would operate to the disadvantage of the railways, and to oppose it when its adoption would, apparently, operate to their advantage. In the second place, while it might be equitable and desirable for society to adopt the single tax doctrine, thereby appropriating all increment in the value of land, it seems both inequitable and inexpedient to apply the doctrine to certain forms of property while failing to apply it generally. Why should the public confiscate the unearned increment of the stockholders of railways and not appropriate that of owners of city real estate, of mines and of farms? Finally, as already intimated, the actual cost theory appears to have no standing in law. In the San Diego Land and Town case it was contended by the company, whose water rates had been reduced, that in considering the reasonableness of its rates the court should give preponderant weight to the cost of its plant; but the Supreme Court said, "What the company is entitled to demand in order that it may have just compensation is a fair return upon the reasonable value of the property at the time it is being used for the public." So the court said in its opinion in the Consolidated Gas case in 1909, "We concur with the court below in holding that the value of the property is to be determined as of the time when the inquiry is made regarding the rates. If the property which legally enters into the consideration of the question of rates has increased in value since it was acquired the company is entitled to the benefit of such increase. This is, at any rate, the general rule." So in its recent decision in the Minnesota rate case, the Supreme Court plainly proceeded throughout on the assumption that valuation for the regulation of rates should be based on the present value of the property. It differed from the counsel and witnesses of the railways, and from most engineers, in regard to the way that the present value should be ascertained, but that the present value was the thing to be ascertained it clearly indicated. The point on which it differed most radically from railway men and engineers related



to the way in which the valuation of land should be made. It is a familiar fact that it costs a railway more than the ordinary market value of land to acquire for railway purposes. Proceeding on the reproduction theory of valuation, most engineers had adopted the view that, since experience shows that land used for railway purposes would, if it were going to be acquired, cost more than its market value, it should be included in the valuation at more than its market value. While the Supreme Court apparently held that the land should be included merely at its market value for ordinary purposes, it is significant that it said, "the property is held in private ownership, and it is that property, and not the original cost of it, of which the owner may not be deprived without due process of law."

It would seem to follow, then, that, so far as may be practicable, valuation for the regulation of rates must be made in the same way as valuation would be made if it were intended to condemn the properties of the railways and take them under the power of eminent domain. There is, however, one extremely important difference between valuation for the purpose of rate regulation and valuation for the purpose of condemnation. When a valuation is made for the purpose of taking property under the power of eminent domain, one of the principal factors ordinarily considered is the earning capacity of the property; and the net earnings are, of course, the best index of a property's earning capacity, and therefore, of its market value. But in the valuation of a public utility the purpose is to ascertain the ratio of the net earnings to the value of the property as a means of determining whether the utility's rates are reasonable. Obviously, in a valuation to find out whether net earnings are reasonable, net earnings cannot be used as a main factor in the valuation. Therefore, the estimate of the present value of a public utility must be based chiefly on what it would cost to reproduce its property in its present condition. This is a very different thing from basing the valuation chiefly on the actual cost of the property.

The fact is, that the actual cost theory is based on the premise, not that the owners of public utilities are entitled to a fair return on the fair value of their properties, but on the ground that they are entitled merely to what is considered a fair return; and the assumption is that if the owners receive, let us say, 5, or 6, or 8 per cent. on their actual investment throughout the entire life of the enterprise, they are getting a fair return. But this is not at all the principle repeatedly laid down in the courts. The principle laid down by the courts apparently is that public utilities are entitled, whenever their rates are regulated, to have the fair value of their properties ascertained, and to have their rates so adjusted as to cause them to receive a fair return on their value at that time, whether that value be more or less than the cost of the property. In rendering the opinion of the Circuit Court in the Nebraska rate case, Justice Brewer intimated that there might be reasons why valuation in a rate case ought to be made even more liberal than in a case involving the condemnation of property. "Is there not," he said, "an element of equity which puts reduction of rates in a different attitude from the absolute taking of the property by virtue of eminent domain? In the latter case, while only the value is paid, yet that value is actually paid, and the owners may reinvest and take the chances of gain elsewhere; whereas, if the property is not taken the owners have no other recourse than to receive the sum which the property they must continue to own will earn under the reduced rates."

The application of the present value theory, when the present value exceeds the cost of the property, may seem to be unjust to those who pay the rates; but is its application in these circumstances any more unjust to the rate-payers than it is to the owners of public utilities when the present value happens to be less than the actual investment? The making of a valuation based entirely on present value presents great difficulties; but does it present any greater difficulties, in the case of most railways, than would the ascertainment of their actual cost?

## Letters to the Editor.

### ENGINE HOUSE PAY.

NEW YORK, August 19, 1913.

TO THE EDITOR OF THE RAILWAY AGE GAZETTE:

The engine house has been subject to much abuse, and not only is it accused of engine failures that properly are chargeable to the transportation department, but a policy of wasteful economy stifles all attempts at improvement. Roughly, men are paid for two things—brains and brawn, graded between foreman and laborer; the general foreman is paid for executive ability and knowledge, the mechanics for both skill and physical exertion, and the laborers for toil alone. To promote proper respect for the man in charge of perhaps a million dollars' worth of company property, his salary should exceed that of any of his subordinates, yet there are engine houses in which the hourly rate of certain mechanics gives them a larger remuneration than their superiors who are on a monthly salary.

Again, there are engine house men who have served a score of years with no increase in their hourly rate, yet all this time they have been storing up experience and educating themselves for more responsibility, the latter being gladly given to them, but not more pay. Indeed, raw, untrained helpers are received upon the pay roll at precisely the same rate that is given to these older men. No policy could be more conducive to dishearten men or to create a feeling that the company is ungrateful. I recall a man who started at the lowest rate as a laborer 22 years ago. During this long period of continuous service he has acted as doper, wiper, ash pit shoveler, fire cleaner, hostler, and as mechanic's helper, and has performed or is familiar with almost every duty in the round house. Surely his services are worth more today than are those of a new man, yet he still draws the lowest laborer's rate. If a foreman, acting through his master mechanic, only had the authority to adjust the rates of pay so that the lower employees would be treated like human beings rather than mere numbers in the pay master's book, I believe a big problem in round house efficiency would be solved.

—Terminal Foreman.

RAILWAY COAL DEPOT IN SOUTHERN FRANCE.—The Paris-Lyons-Mediterranean Railway, generally known as the P. L. M., is considering transferring its principal coal depot in southern France from Marseille to Port Saint-Louis-du-Rhone, 30 miles distant. This would mean a material reduction of traffic at Marseille, as the P. L. M. is much the largest coal importer in the district. This company received at Marseille during the last three years an average of over 450,000 tons of foreign coal, or about 30 cargoes each year. All these supplies were purchased through the company's headquarters in Paris.

STEEL CARS IN THE TROPICS.—It has, hitherto, been considered inadvisable to operate steel passenger cars in tropical countries, because of the climatic conditions which prevail there, and in adopting a new type of all steel cars for passenger service the South Indian Railway would seem to be embarking upon a policy which has, up to the present, remained untried. Although the cars are of steel construction, every precaution has been taken in designing them to avoid the risks and inconveniences which otherwise would have been experienced. The tests made with the cars have shown remarkably good results. In the matter of internal temperature some very satisfactory results have been reached, a saving in weight, as compared with the latest wooden cars of the same dimensions, has also been effected. This saving would undoubtedly have been exceeded had the designers preferred not to make too sudden a departure from existing standards. It is interesting to note that several other railways in India and Egypt have placed orders with the manufacturers of these South Indian Railway cars for steel coaches.

# MOUNTAIN RAILWAY ELECTRIFICATION.\*

A Study of the Tehachapi Pass on the Coast Lines of the Southern Pacific in California. A Busy Line with Heavy Grades.

By ALLEN H. BABCOCK,  
Electrical Engineer, Southern Pacific.

During the past ten years the Southern Pacific has investigated the question of electrification of its three outlets from the central valleys of California, north over the Siskiyou mountains, east over the Sierra mountains, and south over the Tehachapi Pass. The earlier reports, inspired directly or indirectly by manufacturers as a part of their propaganda program, were favorable to electrification. The railway company then began studies of the subject, independently. The conclusions of its officers were unanimously opposed to electrification, by reason of the financial results to be anticipated; however, some of its lines have been electrified, and other electric lines have been acquired for good reasons.

Lately there has been a constant and persistent pressure put upon the company officials, both by power companies and consulting engineers, to reconsider decisions adverse to electrification. Just how much of this agitation has been due to the application of general statements regarding the benefits to be secured by electrification of the particular problems presented by west coast mountain railroading is hardly susceptible of direct determination. It is possible, however, that much of it is due to the effect that such hypothetical studies and papers as have been published recently have produced upon executives, who, however skilled they may be in their specialties, only in rare instances are sufficiently experienced technically to be capable of forming independent opinions on engineering matters. It is a fact that reports adverse to electrification in the hands of these same executives often cause disappointment and sometimes arouse criticism.

Here, then, are two opposing parties: the one with things to sell (apparatus, power, engineering skill), the other with a service to be maintained, at decreased cost if possible, but necessarily maintained at any cost; the first reports favorably upon projects that the second considers unfavorably with equal positiveness. Some things must be unknown to both. Either the radicals have not all the facts upon which to work, or the conservatives cannot interpret their facts correctly.

This paper is written, not with the intent to offer anything original in the study of such problems, but to give the facts of a typical west coast mountain railroad district and their interpretation as seen by one whose reports heretofore have been responsible for many adverse decisions in such matters. It is not intended to be the final word on the subject of electrification of this district, but it is the result of a study recently made to determine whether there was such a reasonable chance for profitable electrification as would warrant a very considerable expense in time and money.

## PHYSICAL CHARACTERISTICS.

West Slope, Bakersfield to Summit.....49½ miles  
Vertical rise .....3,764 ft.  
Average grade .....1.44 per cent.  
Average curvature equal to a constant 3 deg. curve.  
Total curvature, 7,944 deg., of which 6,969 deg. are between Caliente and Summit (27.2 mi.). The loop curve has a total curvature of 566 deg. 33 min. 12 sec.  
East Slope, Mojave to Summit.....18.3 miles  
Vertical rise .....1,285 ft.  
Average grade .....1.33 per cent.  
Average curvature (as above).....0.79 deg.  
Total curvature .....765 deg.

The ruling grade on each slope is 2.2 per cent., but these grades are not compensated for curvature so that in effect the ruling grade is 2.4 per cent. The maximum grades are long enough to fix the weight and power of the locomotives. The average distance between sidings is approximately three miles.

\*Abstract of a paper presented before the American Institute of Electrical Engineers, at a meeting held in Vancouver, B. C., on September 9-11, 1913.

In determining the energy consumption of trains moving over the mountain the actual characteristics of the line were used, but in determining load diagrams and substation spacings and capacity, the following close approximations were made to take care of the ruling grade, curves, etc.

Section.	Miles.	Average grade.
Bakersfield to Edison.....	7.2	0.5 per cent.
Edison to Caliente.....	15.1	1.5 per cent.
Caliente to Summit.....	27.2	2.4 per cent.
Mojave to Cameron.....	10.8	2.4 per cent.
Cameron to Summit.....	7.5	0.75 per cent.

The average freight train, eastbound, weighs 2,000 tons, exclusive of locomotives. Four consolidation type locomotives, or their equivalent in Mallet compounds, are used to haul this train from Bakersfield to Summit. From Summit to Mojave one locomotive is used for supplying air for brake purposes, etc., and the

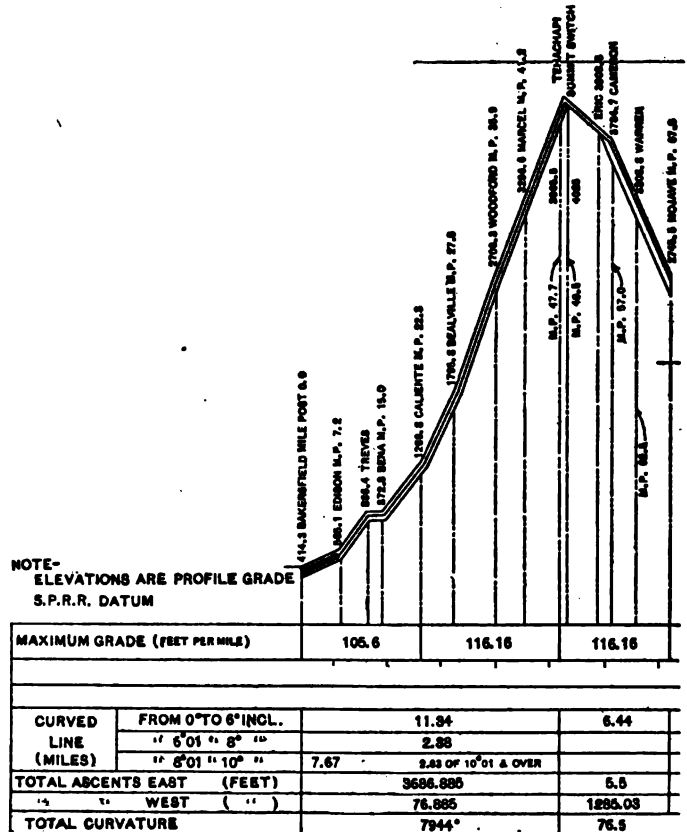

Condensed Profile, Tehachapi Pass.

other three return deadhead to Bakersfield. The westbound freight trains are lighter than the eastbound on account of the fact that much of the western movement consists of empty cars. The normal weight is 1,250 tons, hauled by three consolidation locomotives, or their equivalent in Mallets; or a 1,500-ton train operated by three consolidation or decapod locomotives, or their equivalent in Mallets. The helper engines cut out at Summit and return light to Mojave. In order to provide a flexible unit it was proposed to use an electric locomotive, capable of handling a train unit of 500 tons, as many per train to be used as the weight of the train requires. The weight of the electric locomotives is assumed at 100 tons.

Passenger train weights vary from 250 tons to 600 tons, for which a single passenger locomotive weighing 150 tons was pro-

vided. A maximum freight train movement over the mountain recently consisted of twelve full-size freight trains, eastbound, and eight full-size freight trains, westbound, in addition to the normal passenger movement, which is seven regular trains each way per day, with occasional extras and second sections.

The track, particularly on the west slope, is laid for the greater part of the distance in rough country. In fact between mile posts 326 and 361 all the track, with the exception of a short stretch near Caliente, is in cuts or on fills. It may be said generally that at least half the track is laid in conditions where any overhead contact system would require, necessarily, very expensive steel pole or bridge construction. In addition to the above, there are 18 tunnels, in none of which the vertical clearance is more than 18½ ft., and 60 per cent. of their total length is on 10 deg. curves.

Experience with similar earlier reports has shown that, in general, there is little difference in total first cost and annual operating costs, whether an overhead system or the third rail system be considered. A double overhead contact system gives maximum first cost and operating costs for contact system, and minimum weights, costs and maintenance of locomotives; a single overhead contact system gives high first cost and operating costs for contact system, with maximum weights and maintenance of locomotives; the third rail gives high first cost and minimum operating cost of contact system, medium locomotive weights and first costs, with minimum operating costs, but the total costs are brought up to the level of the others by reason of the necessary substation apparatus and attendance. A choice of systems therefore is to be made only after an exhaustive study of all the local conditions. In a preliminary study, as this is, it matters little what particular system of propulsion is chosen, upon which to base the estimates. For the purposes of this discussion a 2,400-volt continuous-current, third-rail contact system was selected for the main line, with an overhead contact system in yards and terminals, at Kern, Bakersfield and Mojave.

In the following, the first costs are based on the present traffic as shown by the train despatcher's sheets; the annual operating costs are taken from the reports of the fiscal year ending June 30, 1912, for steam operation, while the same traffic and reports are used, as far as they apply, in estimating the costs for electric operation.

FIRST COSTS.	
Substations .....	\$1,610,000
Generating station .....	1,760,000
Transmission system .....	430,050
Contact system (yards).....	155,250
Contact system (line).....	825,000
Bonding .....	122,300
Block signals .....	175,000
Shops and inspection shed.....	10,000
Electric locomotives .....	2,085,000
<b>Total .....</b>	<b>\$7,172,600</b>
Credit by steam locomotives released for service on other divisions .....	1,464,900
<b>Net first cost.....</b>	<b>\$5,707,700</b>
ANNUAL OPERATING COSTS. (Steam-generated power.)	
	Steam. Electric.
Substation labor and supplies.....	\$59,700
Power house labor and supplies.....	84,780
Transmission and contact system maintenance .....	36,576
Maintenance of way as affected by locomotives .....	\$126,890 83,285
Locomotive repairs .....	270,990 70,701
Locomotive enginemen (passenger).....	48,300 29,100
Fuel .....	240,852 100,530
	\$687,032 \$464,672
Bond interest at 4½ per cent.....	..... 256,847
<b>Totals .....</b>	<b>\$687,032 \$721,519</b>
Net loss, \$34,487	

In the above no account is taken of items not affected by the character of motive power: freight enginemen, and all train crew wages, repairs to cars and maintenance of way as affected by cars—for example.

The net loss under proposed electric operation is so small that it might be wiped out by a reasonably small change in the

assumptions; in fact, at this stage of similar investigations often there is a temptation to search for opportunities to change this, or to modify that, as the necessities of the case demand. This important fact should be borne in mind, however, that in the foregoing no account is taken of taxes and depreciation, both of which must be paid, some time, by some one, to the extent of at least 5 per cent. of the net investment, which increases the net loss by approximately \$285,000 per year.

It may be asked, why is depreciation not taken into account in the usual manner? The answer is, since there is a loss, or at least no profit shown, and since to add depreciation would be to make a bad matter only worse, nothing is to be gained by entering into the academic discussions that inevitably follow the opening of a subject concerning which opinions reasonably may differ as widely as on this much disputed particular.

But power may be purchased, as is often suggested by those with power for sale, hence it is proper to determine at what rate this power may be purchased and come out even as compared with operation by steam-generated power. Obviously any rate less than this will be profitable.

With purchased power, the total investment will be diminished by the costs of 20 miles of transmission line and of the generating station, it being assumed that power will be delivered at some one point on the right-of-way, whereas local conditions located the steam station 20 miles off the right-of-way at a point six miles east of Bakersfield where there is a large oil field from which the company obtains much of the fuel oil used in its locomotives. Plenty of water for condensing purposes is obtainable near by. The annual charges on a transmission line under these conditions do not impose so heavy a burden on the operating costs as would the delivery of oil at the right-of-way; besides, to develop sufficient water along the track would cost a great deal.

The net first cost was.....		\$5,707,700
Transmission line .....	\$120,000	
Generating station .....	1,760,000	1,880,000
<b>Leaving a net investment with power purchased .....</b>		<b>\$3,827,700</b>
ANNUAL OPERATING COSTS. (Power purchased.)		
	Steam.	Electric.
Substation labor and supplies.....	.....	\$59,700
Transmission and contact systems maintenance .....	.....	35,576
Maintenance of way as affected by locomotives .....	\$126,890	83,285
Locomotive repairs .....	270,990	70,701
Locomotive enginemen (passenger).....	48,300	29,100
Fuel .....	240,852	.....
	\$687,032	\$278,362
Bond interest at 4½ per cent.....	.....	172,247
<b>Totals .....</b>	<b>\$687,032</b>	<b>\$450,609</b>

The difference, \$236,423, should be decreased by \$191,385 (the approximate tax and depreciation rate of 5 per cent. on the net investment of \$3,827,700), and there is left the wholly inadequate sum of \$45,038 with which to purchase 53,000,000 kw.-hr. at a load factor of about 20 per cent.; with no profit to show for an investment of nearly \$4,000,000.

For the sake of the argument let the depreciation be neglected and let it be considered that \$236,423 are available for the purchase of power under the operating conditions of the service. At any time there may be four passenger and four freight trains pulling up hill simultaneously, taking a total of 32,720 kw. alternating-current input to the line. This is not the maximum number of trains that is on the mountain regularly, but represents only those taking power. A slight derangement of schedules, or an extra freight movement, of citrus fruits or oil, or a blockade, for example, will cause congestion beyond any possibility of estimating. This traffic must be handled as circumstances require. It cannot be spaced conveniently for power demands, as many engineers and power men have suggested, but the terminal yards must be cleared as the cars accumulate. This amount would net about 4½ mills, a rate that neither the purchaser nor the seller could afford to consider.

In the face of the foregoing it is difficult to see how any

recommendation in favor of electrification can be made, if the opinion is based on the direct financial profit to be realized; in other words, this case is merely another example of the fact, often noted, that in the great majority of cases the profits from electrification must be realized indirectly rather than directly—increased track capacity, postponing second-tracking, or the like.

At the present time the entire district between Mojave and Bakersfield is protected with automatic block signals of the usual continuous-current track circuit battery type. In case of electrification a great part of this apparatus will have to be replaced with alternating-current track circuit apparatus, because the use of track circuits with propulsion current in the rails requires selective apparatus to prevent false indications. The estimate of the signal department for making these changes is \$175,000.

As the company has important division shops located already at Bakersfield, a large item for repair shops is not necessary, it being understood that the heavy electric locomotive repairs would be done in the steam locomotive repair shops. An inspection shed with pits, however, is necessary, for which the lump item of \$10,000 was included, this being in the ratio of cost of the track facilities required here to the cost of similar track facilities in a shop recently erected by this company.

An analysis of the train sheets covering the period of maximum tonnage over the mountain shows that there will be required 47 freight locomotives, and 11 passenger locomotives, which includes a reasonably large allowance, namely, 8 freight and 3 passenger locomotives, for repair and shopping purposes. The locomotives required for this service are so closely similar in characteristics to those upon which quotations were asked recently from the electrical manufacturers that new quotations were not requested for the purposes of this estimate, particularly since the locomotives actually quoted on were for the same operating voltage, etc., as are contemplated herein.

The unit costs were: passenger locomotives \$40,000, and freight locomotives \$35,000, making a total of \$2,085,000 for 47 freight and 11 passenger locomotives.

It seems pertinent here to note the very significant fact that while steam locomotives are strictly interchangeable and can be moved from division to division as the necessity for varying motive power capacity develops, by reason of crop movements, or otherwise, the electric locomotives are limited in their field of operation strictly to electrified track, and as far as interchange between divisions is concerned they might as well be of some gage other than standard. An inspection of the records of the operating department shows that during a period of heavy traffic over the mountain there were in actual service 13 passenger 47 consolidated and 13 Mallet locomotives, which, if taken at the same valuation as was used in a recent report on the Sierra Nevada electrification, would represent an investment of \$1,220,750, to which should be added at least 20 per cent. for extras, shopping, repairs, etc., making the total investment in steam locomotives properly chargeable to this district = \$1,464,900.

Many years' experience in the analysis of track maintenance accounts has shown that, independent of all other considerations, track maintenance as affected by rolling stock can be divided into two heads, locomotives and cars, the segregated costs of which have been determined very accurately. Reduced to dollars and cents, the auditor's accounts show that locomotives of approximately the same weight and run at the same speeds as those contemplated in this report, caused maintenance of way expense at a certain rate per locomotive mile, from which has been deduced the item, \$83,285, given in the statement of annual operating costs. That for steam operation, \$126,890, is taken from the records.

The figure given for locomotive repairs for steam operation is taken directly from the records. The estimated cost of electric locomotive repairs, four cents per locomotive mile, is based

on our analysis of the best data available for such costs. As to this value, opinions reasonably may differ, but it probably will be recognized that the figure named gives a rather favorable consideration to the use of electric locomotives, since the repair accounts of some of the larger railroads operating the largest electric locomotives in this country show repair costs materially more than four cents, all things considered.

## A PLEA AGAINST HASTY LEGISLATION.

The following telegram was sent Wednesday by presidents of Chicago railways to William C. Adamson, chairman of the house committee on interstate and foreign commerce; to Francis G. Newlands, chairman of the Senate committee on interstate commerce, and to E. E. Clark, chairman of the Interstate Commerce Commission:

The undersigned, being officers of railways whose names appear in connection with our signatures, note with concern that, because of some recent serious railway accidents, there are being proposed in congress measures intended to require railways to immediately substitute steel passenger train cars for their wooden cars and to generally install block systems, or even automatic train stopping devices.

We are but too keenly aware that the accident record of railways in the United States is unsatisfactory. We fully recognize the right and duty of congress to take any reasonable action that may be adapted to reduce the number of accidents, but we beg respectfully to suggest that the measures being advocated are in some respects too broad and in others too narrow in their scope and that, therefore, if they were adopted they would not accomplish the beneficent results desired.

As to steel cars a recent investigation disclosed 90 per cent. of all passenger train cars acquired by railways in 1912 were of all steel and steel underframe construction and that of those under construction January, 1913, no less than 97 per cent. were all steel or steel underframe construction. Railways, without legislation, are ordering all steel and steel underframe cars faster than the manufacturers can supply them; and it is estimated that even if it were practicable now to replace all wooden cars with steel cars, the cost of doing so would be \$633,000,000.

As to block signals, while they are a recognized safety device, the Interstate Commerce Commission showed in its annual report that out of 49 collision accidents investigated by it, 48 had been caused by failure of some employee to do his duty and that of these, 13 had occurred on lines having block signals.

Steel cars do not prevent accidents; merely mitigate their effects; and the figures just cited show also that block signals are no specific for collisions. Furthermore, all legislation proposed deals only with train accidents; and the statistics of the Interstate Commerce Commission show that fatalities and injuries occurring in train accidents are a relatively small part of the total. They show that if there had not been a single collision in the fiscal year 1912, no less than 96.5 per cent. of all those killed on railways would have been killed anyway, and that if there had not been an accident of any kind to a single train, 92 per cent. of all who were killed would have been killed anyway.

A clear majority of all persons killed are trespassers on railway property, the number of trespassers killed in 1912 being 5,434, which was 39 times as great as the number of passengers killed in train accidents and 7 times as great as the total of all classes of persons, except trespassers, killed in train accidents.

A great many accidents, other than those in train accidents and trespassers are due, like them, not to deficiencies of the structures or equipment of railways, but to careless and reckless conduct of individuals, as clearly appears from the statistics of the Interstate Commerce Commission.

In view of these facts, we respectfully suggest that any action regarding railway accidents which congress may take should be designed to secure ascertainment of causes and application of the remedies for all classes of accidents. The fact that if, in the

fiscal year 1912 there had not been a single accident to a train in the United States, 92 per cent. of those who were killed on railways would have been killed anyway, shows that the situation would be very inadequately dealt with by legislation aiming merely to remove causes or to mitigate effects of accidents to trains alone.

Signed by

Daniel Willard, president of the Baltimore & Ohio.

R. H. Aishton, vice-president of the Chicago & North Western.

Darius Miller, president of the Chicago, Burlington & Quincy.

S. M. Felton, president of the Chicago Great Western.

Fairfax Harrison, president of the Chicago, Indianapolis & Louisville.

A. J. Earling, president of the Chicago, Milwaukee & St. Paul.

H. U. Mudge, president of the Chicago, Rock Island & Pacific.

C. H. Markham, president of the Illinois Central.

J. J. Bernet, vice-president of the New York Central Lines west of Buffalo.

F. A. Delano, president and receiver of the Wabash.

B. L. Winchell, vice-president of the Union Pacific.

### ORIGINAL COST VERSUS REPLACEMENT COST AS A BASIS FOR RATE REGULATION.\*

By RAYMOND V. HAYES.

There is at the present time no well defined basis upon which the fair present value of the properties of public utilities shall be ascertained. The rulings which have been rendered by courts and commissions agree in but one thing, that the fair present value can be determined only by the impartial judgment of a court or commission when such a tribunal has been well informed as to all the facts and figures relating to a particular property. The courts have gone so far as to indicate the figures which are needed for their information in establishing a fair basis of this kind. Of these figures, the two which unquestionably have been considered most important by appraisers, are (1) the cost-new as of the present time, usually termed the cost of reproduction or the replacement cost; and (2) the original cost.

There are two parties directly interested in every valuation of public utilities: the users of the enterprise, who will be spoken of hereafter as the public, and the security holders. Naturally these two parties have divergent aims in the establishment of the value of the property upon which rates are to be based. The users desire that this basis shall be made no higher than is just and proper, and the security holders and managers are insistent that their property shall be given its full value as a complete operating and earning enterprise. It is common, therefore, to find much difference of opinion as to the propriety of the inclusion or exclusion of certain items of possible cost or value. Moreover, it is difficult for parties so directly interested in the decisions of the tribunal to present the various figures, representative of value, which have been demanded by the courts. As a consequence each side usually presents that figure which will be most favorable to the end desired, a high or a low present value.

Notwithstanding repeated decisions to the effect that fair present value can be established only when a knowledge of all facts and figures have been presented to the rate making tribunal, nevertheless there has grown up within the last few years a too general acceptance of the cost of reproduction as the true index of the fair value of a property for rate making purposes. This figure is attractive to the holders of the securities of public utility enterprises, for the reason that it is usually larger than the figures that might be obtained by other means. The replacement cost during recent times has usually been larger than other figures representative of value, owing to the increased cost of labor and material and to certain more or less arbitrary assump-

tions usually employed in the derivation of replacement cost, but more especially to the advances of late years in the values of real estate in most parts of this country.

The replacement cost is the sum of money which would have to be expended at the present time to reproduce a physical property identical with that in existence at the present time and used for the benefit of the public. In deriving it an inventory of the entire physical property must be made, and to every unit found in the plant must be applied costs representative of what would have to be paid today for the material and for the labor necessary to place the material in the position now occupied by the existing plant. The replacement cost of land is its present market value, to which must be added the expense which would be incurred in its purchase. Again, most public utilities have portions of their plant in the streets. In many places the streets have become so filled with the conduits or pipes of other utilities, since the plant under valuation was built, that an existing system could be replaced at the present time only at a far greater cost than was incurred when the plant was originally installed. Again, much of the construction of the existing property was placed in the streets before the streets had been paved or, at least, before they had been surfaced with a present higher grade pavement. In consequence of such street improvements, the cost of construction at the present time would be considerably greater. A rigid adherence to the theory of replacement costs demands that these enhanced costs should form a portion of the replacement cost.

Original cost, on the other hand, is the sum of money which was expended by the undertaking for the property now in use for the benefit of the public. It is not what the original property cost, but rather what the present property cost. It is possible that the expression "original cost" conveys a false impression and that the "actual cost" of the property now in use would be less confusing. It is most important that the original cost should not be considered to be the cost of the first unit of plant used in a particular place or for a particular purpose. Elements of plant which are no longer in use or useful cannot be considered as a portion of the property to be included in a valuation for the purpose of determining a fair value for rates. Such plant elements have passed out of existence and their cost should have been removed from the assets of the company. If the business of the undertaking had been conducted properly, reserves for depreciation should have been made. These reserves are obtained from users through the rates paid for the service. Manifestly it is unfair to the users to demand rates sufficiently high to create a fund for the replacement of obsolete plant and then include the cost of such obsolete plant in a new value upon which new rates should be based.

The original cost has been presented as a figure representative of value in but few appraisals, whereas today the replacement cost is almost always ascertained. There are several reasons for this neglect of original cost. Probably the most controlling reason is that, through a misunderstanding of the true meaning of original cost, such a figure can rarely be obtained. This misunderstanding of original cost is due to the efforts of the advocates of the theory of value based on cost to define the original cost as the stockholders' investment in existing useful property. Such an interpretation of original cost requires an analysis of the company's books, an identification of each unit of the existing plant with the book entries showing its original cost, and a determination of the source of the funds used to pay for each unit. It will be apparent to all who are familiar with the construction, maintenance, and replacement of large public utility properties that such a figure can but rarely be obtained—at best in the cases of enterprises which have been constructed but recently. In most instances plant cannot be identified by the book entries. Nor is it possible to trace the sources of all funds used in constructing the plant. Time and again attempts have been made in valuations to derive a figure representative of original cost in accordance with such a definition, and without success. The replacement cost has become, therefore, the only figure which

\*Reprinted by kind permission from the *Quarterly Journal of Economics* for August, 1913. The author has been for some years chief engineer of the American Telephone & Telegraph Company, and more recently consulting engineer in valuation cases.

rests on definite knowledge of the existing property, and a figure representative of original cost has not been presented to the rate making tribunal.

The original cost has been called for by the courts as one of the figures representative of value which must be ascertained to assist the rate making tribunal in forming its judgment as to the fair present value of a property. It is a figure, consequently, of quite the same importance as that representing the replacement cost. The responsibility is upon the engineer, therefore, to find some way whereby the demand of the courts can be complied with and an accurate determination of original cost be made.

The original cost, if the above interpretation of its meaning is accepted, can be ascertained in a manner almost identical with that used in determining the replacement cost. The inventory, describing all useful property now in service, is identical for the two purposes. The unit costs will be different, however. The unit costs used in ascertaining replacement costs are, theoretically, the prices for labor and material prevailing at the date of valuation. Practically, it is usual not to take actual present prices, since such figures may have been affected by abnormal market conditions, but a figure for each unit of plant representative of a probable present cost had market conditions been normal. The unit costs used in ascertaining original costs will be the actual prices of labor and material paid by the company in each year in the past in which plant units had been purchased and installed. Thus, instead of a single unit cost for each unit, as is the case with replacement costs, there will be as many unit costs for each unit as there are years in which existing units have been purchased.

This method of ascertaining original cost is not as difficult or laborious as at first thought it may appear. The age of each unit of perishable property must be determined in every valuation for the purpose of ascertaining the loss in value of the unit due to depreciation. The present value, whether that value is based on original cost or replacement cost, is the cost-new less depreciation. The present value is the value of the perishable property in its present condition plus the value of the non-perishable property. With the ages of all units known, it is only necessary to group together units of the same kind and age. The age indicates directly the year in which the units were purchased. The prices paid for each unit in each year in the past can be obtained readily from the books of the company or, if such records are not available, it would be rarely difficult to obtain reliable figures from outside sources. The product of the unit costs for each year, obtained in this manner, multiplied by the number of units found, by a knowledge of their age, to have been installed in that year, gives the costs for each year of the perishable property. The sum of the costs of all units for all years gives the total original cost of all perishable property. To this sum must be added the actual cost of the non-perishable physical property. The non-perishable property consists principally of land. There is usually but little difficulty in identifying the sums paid for land as shown in the company's records. To the original cost of the physical property must be added the usual overhead charges, derived in a manner consistent with the above method.

Original cost, derived in the above manner, presents no difficulties to the appraiser, is founded on a carefully made inventory, and uses unit costs freed from any assumptions. It would seem to be a figure possibly even more reliable than the replacement cost. These unit costs are actual costs; whereas the unit costs used in the derivation of the replacement value are based theoretically upon the assumption that all material and labor must be figured at the prices prevailing on a particular day, but that such prices should be not the actual prices but what they would be if the market were normal. Original cost, being actual cost, avoids the contentious question usually incident to replacement cost, whether such a figure should show the cost of plant replaced in a wholesale or in a piece-meal manner. There are many other similar points favoring the reliability of a figure representative of original cost, derived as described above, which are of interest to the expert on valuations but need not be considered here.

Every consideration tends to show that the actual cost of an existing plant is a more acceptable figure, as far as the accuracy of its determination is concerned, than a figure based upon the suppositious replacement of a plant. All doubt as to the reliability of the books of the company is removed, as the inventory establishes the present useful plant and its age. The books of the company can be trusted to show what has been paid for labor and material and, even if this is doubted, market rates for labor and material for the years in question can be obtained from other sources.

It must be distinctly understood that the above arguments in favor of original cost are not intended to urge the use of that figure to the exclusion of the replacement cost. On the contrary, figures to show the replacement cost are demanded by the courts and must be prepared and presented to the rate making tribunal for its information. The point which it is wished to emphasize is that the original cost is likewise a figure of importance, which has been neglected in the past but is capable of determination with quite as great a degree of accuracy and possibly will be accepted with less controversy.

Moreover, the absence of reliable figures showing original cost has tended to affect the full and original intent of replacement cost. At the outset the demand for figures to show replacement cost arose, unquestionably, from a desire on the part of the court to know what the actual value-new of the property of the undertaking was at the time of the appraisal. The courts wanted to know what it would cost to reconstruct it at that particular time. The courts have said repeatedly that no one of the several figures, to be ascertained by the engineer as a representative of possible value, would be accepted by it in all cases as the *fair* present value-new. It is probable that the replacement cost unmodified would be accepted but rarely as that value. The present tendency, where the replacement cost is the only figure presented to the tribunal, is to change the original significance of replacement cost by using unit costs derived from an average of prices prevailing for a number of years in the past; by rejecting the cost of pavement, unless it can be proved that the pavement had been paid for by the company; by questioning whether the present value of land should be used as a portion of replacement cost; and by eliminating entirely figures representative of the value inherent in a successfully operating enterprise. These and similar modifications of the significance of replacement cost clearly indicate on the part of appraisers to obtain the original cost—the money actually expended for the existing property by the undertaking—by means of more or less arbitrary modifications of replacement cost. With an original cost accurately obtained and a replacement cost showing what it would cost actually to create, at the present time, a new and similar property, the necessity of appraisers attempting to derive a compromise figure would disappear. The decision as to how replacement cost or original cost should be modified to establish a *fair* cost-new must be made by the rate making tribunal and not by the appraisers. Competent appraisers, representing possibly divergent interests, would derive the original cost as well as the replacement cost, following the principles above enunciated, and present figures which would agree substantially. Thus, many of the controversies usual in appraisals would be removed.

The rate making tribunal thus would have two figures representative of value of the property new: the actual original cost and what the same property would cost if reconstructed today. From these two figures and from others relative to the undertaking, the rate making tribunal must assign a present value, fair to both the public and to the undertaking, upon which the return to the stockholders of the undertaking may be based. The question immediately arises as to whether the undertaking is entitled to earn a return upon the fair cost-new or upon the fair cost-new less the loss in value which may have arisen from the years that the perishable property of the undertaking has been in service.

In the case of an actual appraisal it may be found that much of the present property of the undertaking has been purchased with money derived from the public and contributed by it for the

express purpose of paying for the renewals of portions of the plant which may have become unserviceable. The investment of these funds—reserves for depreciation—in needed plant extensions is a wise plan for most successful and growing public utilities, as thereby the undertaking is required to pay a less amount as a return than would be required if new money had been obtained from the stockholders. Moreover, there would be little expense involved in obtaining new money at some later time when funds were required to pay for renewals. Clearly both the original cost and the replacement cost will include, in such cases, the cost of plant built not only with the money of the security holders, but with the depreciation reserve funds. If the reserves for depreciation had been properly made and all invested in plant, the depreciation would equal the depreciation reserves and, if the original cost-new was reduced by the loss in value due to depreciation, there would be eliminated from the original cost the cost of that portion of the plant which had been purchased with the money contributed by the public for the purpose of providing for renewals. If the reserves for depreciation had been inadequate but had been invested in plant, the present value of the property would be less than the original cost of the security holders, thereby penalizing the undertaking for improper management in not making proper reserves for depreciation. Thus it is seen that the present value derived from the original cost can only include the present value of plant purchased with the money of security holders and possibly with excess earnings. It cannot include reserves for depreciation.

Many argue at the present time, that the fair value upon which rates should be based is the money which has been contributed by the stockholders and expended by the undertaking in property now in use and useful. These advocates of the theory of "rates based on cost" would endeavor to have the original cost made the criterion of fair cost-new, provided they could be assured that in the original cost was not included the cost of plant which had been acquired with money obtained through abnormally high rates charged for service in the past. They feel that the undertaking should not be permitted to obtain returns based upon the replacement cost, particularly when a large portion of the property of the undertaking may consist of land the present value of which may exceed by a large amount its original cost. Thus in the case of many railroads, the land may have been purchased originally at a very low figure or may have been donated to the undertaking for the purpose of encouraging the building of a railroad line in sparsely settled territory.

The original cost excludes the unearned increment on land and, so far as this feature is concerned, satisfies those who object to private acquisition of the increment. Derived as above described, and with depreciation subtracted, it does not exclude the value of property acquired through excessive earnings in the past. It shows the money which was expended in the acquisition of the present property but does not distinguish between plant purchased with the stockholders' money and that acquired with the earnings produced by excessive rates.

The only answer that must be given to those who contend that the original cost may be too high is that in a very large proportion of the cases of valuations in this country, the original cost will be found smaller than the replacement cost. In other words, it would cost more to replace the property today than it cost to construct it originally. The excessive earnings of the past were invested in property useful to the public and not paid out as dividends to the stockholders. The present stockholders, in many cases, had bought their stock and invested their money in the property in good faith and with the knowledge that the undertaking had a property of a certain size and was in successful operation. It is not just to these investors that an undertaking with which they have entrusted their money, having property of greater value than the present value based on original cost, should have the value upon which rates can be based still further reduced because a portion of the property may have been purchased with money other than that contributed by the holders of securities. Common justice demands that, provided an under-

taking is well managed and is giving good service but has capital assets in excess of the actual investment of the security holders in the enterprise, the present holders of securities should not be penalized. Capitalization on expected profits, high rates and large dividends, may have formed a financial policy in the past through no act of dishonesty on the part of the management, but simply through the application of those rules for the conduct of the business of private corporations which have been accepted commonly as proper before the distinction had been made between the conduct of private enterprises and that of those vested with public interest. In the case of public utility enterprises such methods of financial operation belong to the past and will never be possible in the future under competent legislative supervision. Justice to the undertaking demands that the past should be wiped out and a new start be made on a basis which is fair to those who have invested their money in the undertaking as well as to the public. In such cases as are now being considered, therefore, the original cost of the physical property less its loss in value due to depreciation should be accepted as a portion of the present value of the entire property based on original cost regardless of the sources of the money used in building the property.

It must be admitted that there will be certain classes of utilities the original costs of which cannot be obtained with the ease which has been claimed in the foregoing pages. The principal exception will be steam railroads. The original costs of land used for roadway and for terminals can be obtained in but few instances. The same may be true of some portions of the property of the older gas and water companies. This would not be true of the property of most telephonic or other electrical enterprises. The present accentuation of replacement cost may be due largely, if not entirely, to the fact that valuations of railroad properties were among the first made and that the precedents thus established have been followed in the valuations of other classes of utilities.

It is most important for the interests of public utilities that the original cost should be recognized, ascertained, and presented as an indication of value, in order that the replacement cost may be given its full significance, and not be reduced by the more or less arbitrary exclusion of certain items of value which clearly are the property of the undertaking. A corporation is entitled to a return, upon the present value of its property, which is not so low as to be confiscatory. The present value of the property, not necessarily the *fair* present value upon which rates should be based, is what that property would cost if reproduced at the present time less the loss in value which may have arisen from the time it has been in service. Clearly land is worth its full market price at the present time; likewise, construction in the streets is worth as much as it would cost a possible competitor to create a similar plant today. The same is true of similar items the value of which has increased with the development of the territory in which they are situated. The present value of the property of an undertaking is the full replacement cost, less depreciation, of all property in use or useful to the public at the present time, and upon that value the courts may be relied upon to hold that a return can be earned of an amount which is not so small as to be confiscatory.

Whether the replacement cost is the *fair* present value upon which a return is to be earned sufficient to requite the stockholders for their enterprise in developing the business and for the risk incurred in its promotion, must be left to the rate making tribunal to decide after all facts and figures have been presented for their information. The advocates of the theory of rates based on cost cannot attack the replacement cost. They can attack the acceptance of the replacement cost less depreciation as the sole fair basis of rates, and that is all. The original cost less depreciation, ascertained as has been described above, is also a figure important for the application of the cost theory, and should be equally before the rate making tribunal for its consideration. No arbitrary ruling as to which figures shall be given dominating importance can be laid down, as other facts and figures must be known to the tribunal.

### CONSTRUCTION OF THE PORTLAND, EUGENE & EASTERN.

The Portland, Eugene & Eastern was incorporated to electrify two branches of the Southern Pacific near Portland, Oregon, and two small steam roads which have been purchased, in addition to building a new electric interurban line from Portland to Salem, Corvallis and Eugene. When this construction work is finished the company will operate a network of electric roads which will cover practically the whole Willa-

almost half of the total crop of hops grown in the United States; and the products of truck gardens, dairy farms, agriculture and forests will also furnish some freight traffic. The decision to spend \$12,000,000 in building an electric system was reached in 1910 following a complete examination by Robert E. Strahorn, who is at present the president of the company.

The new main line from Portland to Eugene will be about 125 miles long and the total mileage, including all branches will

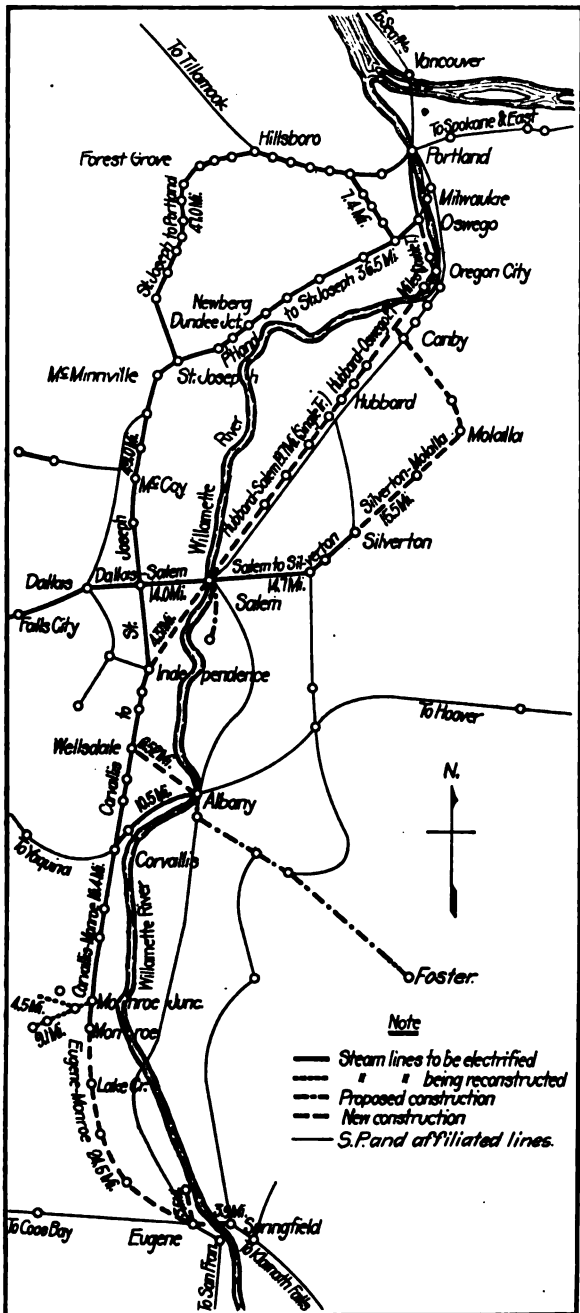

Map of Portland, Eugene & Eastern System.

mette valley, and which it is expected will handle a large amount of freight from the ranches and orchards in the valley to the markets and shipping points in the larger cities, in addition to an important passenger traffic. The territory tributary to the line contains 190,000 people, exclusive of the city of Portland and the county in which it is located, the density of population being 19.5 per square mile. The Willamette valley contains the largest and most productive, pruned and cherry orchards in the northwest; one of the counties tributary to the new line raises



New Station at McMinnville, Ore.

be about 340 miles. The terminal in Portland will be on Fourth street near the center of the retail district, and in entering the city the line will cross most of the principal street car lines, which will make it easy for passengers to reach any portion of the city. The new main line south of Portland will use the existing Southern Pacific tracks to Oswego. From Oswego to Hubbard, 21 miles, a new double track line will be built, one track to be used by the interurban cars, and the other by the Southern Pacific main line steam trains. This location will reduce the distance on the Southern Pacific between Portland and Salem, and will also improve the line as to curvature and grade, reducing the maximum grade from 1.5 per cent. to 0.5 per cent. The character of the work on this section is shown by the quantities of material to be moved which are as follows: Rock excavation, 11,650 cu. yds. per mile; earth excavation, 43,450 cu. yds. per mile; embankment, 61,950 cu. yds. per mile; overhaul, 765,700 cu. yds. at an average distance of 12,350 ft.

From Hubbard to Salem, 19.7 miles of new single track line will be built to a 0.5 per cent. maximum grade. At Salem the



Recently Completed Bridge Across the Willamette River at Salem, Ore.

new line will cross the Willamette river on a new bridge recently completed at a cost of \$300,000. This bridge also serves as an entrance to Salem for the Salem, Falls City & Western, a small steam road which has been purchased and which will be electrified as far as Dallas. A new cut-off has been built from Salem to Independence, 4.31 miles, which will form a link



in the new main line of the interurban system joining the old line of the Southern Pacific at Independence. Another cut-off is being built from Wellsdale on the old Southern Pacific line to Albany, allowing the new electric service to reach that point. From Albany to Monroe, the present line will be electrified, and from that point south to Eugene, 24.5 miles, a new single track line is being built to a maximum grade of 1.5 per cent., which involves only light grading, with the exception of one cut containing 29,000 cu. yds. of solid rock.

In addition to this main line, the system will include a branch from Canby through Molalla and Silverton to Salem. The Canby-Molalla section of this line, 11.35 miles long, is now under construction. It is being built to a maximum grade of 1 per cent., the grading being very light. The proposed line from Molalla to Silverton will be 15.5 miles long, will have a maximum grade of 2 per cent., and the grading will involve the following quantities: earth, 18,000 cu. yds. per mile; loose rock, 3,300 cu. yds. per mile; solid rock, 2,050 cu. yds. per mile, and overhaul, 242,600 cu. yds. The section from Silverton to Salem will use the present line of the Salem, Falls City & Western, which will be electrified. The present branches of the Southern Pacific west of Portland, known as the West Side and Yamhill branches, reach Forest Grove, St. Joseph, McMinnville and Independence. The completion of the main line and the electrification of these two branches will provide three distinct routes into Portland for Willamette valley shipments.

The franchise for entering Portland over Fourth street has been granted and material for the construction has been received. The electrification of the two branches forming the McMinnville loop is practically completed, these lines having been practically rebuilt. New depots have been erected at McMinnville and Forest Grove and at Newberg, McMinnville, Forest Grove and Hillsboro the line has been changed in order to locate the interurban terminals in the centers of the business sections. New rails have been laid on the old line from McMinnville to Monroe and the new line from Monroe to Eugene will be ready for operation within a short time. The Molalla line is graded from Canby to Molalla and track will be laid in a short time. Material is on the ground for the completion of the new main line from Oswego to Salem. The Portland, Eugene & Eastern has also acquired the street car systems at Salem, Albany and Eugene and is now building the system at Corvallis. It is now operating 15 miles of street railways at Salem and 17 miles at Eugene.

The electrified line from Portland to McMinnville by way of Forest Grove and back to Portland by way of Newberg, and the Beaverton cut-off from Beaverton to Cook will be served by three substations located at Oswego, Forest Grove and Dundee. Electric power will be received from the Portland Railway, Light & Power Co., at Milwaukie at 60,000 volts, 3-phase, 60 cycles, this power being generated at three plants located at Oregon City, Cazadero and Bull Run with outputs of 10,000, 25,000 and 20,000 h. p. respectively. This power will be transmitted over the company's transmission line to the Oswego substation, where two 1,000 k. w., 3-phase transformers will transform it from 60,000 volts to 13,200 volts. One transmission line will feed the Forest Grove substation from Oswego and another will transmit the power at 13,200 volts to the Dundee station. These transmission lines are of No. 1/0 7-strand hard drawn copper wire with a 3-ft. spacing and with all three wires arranged in the same plane on the crossarm. The Forest Grove and Dundee substations will be reinforced concrete fireproof buildings and will each contain two synchronous motor-generator sets of 500 k. w. capacity. These sets will supply energy to the trolley line at 1,500 to 1,575 volts d. c.

In addition to the motor-generator sets, each substation will contain the usual equipment of oil switches, switch boards and control apparatus. A small storage battery will be provided for furnishing control current for the operation of the oil switches and for emergency station lighting. Electrolytic light-

ning arresters will be provided both on the incoming transmission lines and on the outgoing 1,500 volt feeders. The Oswego substation, in addition to the transformers, will contain the same equipment of motor-generator sets as the two stations above described and will have provision for the installation of a third unit. Six other substations will serve the remainder of the line, to be located at Eugene, Lake Creek, Corvallis, Salem, McCoy and Hubbard. The distance between substations varies from 22 to 25 miles. These buildings will be somewhat similar to those already described. The cost of the Oswego station will be about \$9,000 and that of the other eight will range from \$4,200 to \$5,500 each. The catenary type of construction is to be used for the trolley, a No. 4/0 grooved copper trolley being carried by a 7/16 in. galvanized steel messenger cable of 15,000 lbs. breaking strength. Cedar poles 9 in. in diameter at the top and with the butts treated are being used for this trolley line. Two telephone circuits will be provided, one to be used exclusively for telephone train despatching, and the other to connect substations and emergency line headquarters. A telephone selective system will be installed for despatching service, with selective calling apparatus in the principal stations and telephone sets at all sidings.

The cars will be of all-steel construction, approximately 56 ft. long with a seating capacity of 60 passengers. All cars will be arranged for multiple unit operation with automatic control, and will be operated in trains consisting of all motor cars or a combination of motor cars and trailers. Among the interesting features of the cars and equipment will be the roller pantograph trolley allowing the pantographs to be placed in contact with the trolley wire by the operation of a control switch in the cab of the leading car of the train. As the trolley potential is 1,500 volts and the lighting and control circuits on the cars are arranged for 600 volts, a dynamotor compressor is installed on each car to furnish 600 volt energy for these circuits. This machine receives the 1,500-volt trolley current and by means of a tap on the winding gives 600-volt current for the local circuits. This machine is also provided with a friction clutch and automatic devices which connect the compressor proper to the dynamotor when the air pressure in the brake system has dropped to a predetermined value such that it is necessary to operate the compressor. The dynamotor, acting as a motor, drives the air compressor to recharge the storage tanks. The cars will be equipped with four motors, each wound for 750 volts, but insulated for 1,500 volts. The motors will be connected two in series when operating on the 1,500-volt circuit, and by means of a commutating switch, the connections can be so changed that each motor will be thrown directly across the trolley circuit when the car is operating on the 600-volt city lines. For freight service a number of 1,500-volt, 60-ton electric locomotives equipped in somewhat the same manner as the passenger cars will be provided.

Plans have been made for general car shops near Portland, the buildings for which will be of reinforced concrete construction and will include all modern machine shop facilities. The main shop building will contain a floor area of 40,200 sq. ft. and will cost approximately \$100,000. The yard layout around these shop buildings will include about three miles of track. Other small buildings in connection with the shops include a 20 ft. by 40 ft. blacksmith shop; 16 ft. by 32 ft. inspection office and a 40 ft. by 80 ft. boiler house.

PROPOSED LINE FOR ARGENTINA.—The public works committee of Argentina has under consideration the request of the Central Argentine for a concession for a branch line from Santa Rosa to Luxardo and Obispo Trejo, province of Cordoba. The committee has reported favorably on the petition of the same railway for building a line from Luxardo northwesterly for 15 miles, then on to Obispo Trejo, passing through Santa Rosa; also a branch from Santa Rosa to Sacanta.

# LOCOMOTIVE TRACTIVE EFFORT.

The Development of a Formula Which Includes Allowances for the Limits to the Physical Strength of the Fireman.

By H. A. HOUSTON,  
Rock Island Lines, Chicago, Ill.

The variation of draw-bar pull or tractive effort of steam locomotives depends on two things: first, the cylinder capacity, and second, the boiler capacity. The characteristics of the cylinder and boiler, and their dimensional relation to each other, are generally determined by the character of the service for which the locomotive is desired.

## MAXIMUM TRACTIVE EFFORT AT LOW SPEEDS.

It is a common practice in the design of steam locomotives to proportion the working parts so that at starting they just fail to slip the drivers on a good rail, thereby making the adhesion the absolute limit of tractive effort. In such cases, the tractive effort is determined by the size of the cylinder, the steam pressure in the cylinder, etc., and not by the weight on the drivers and the coefficient of static friction between the wheels and rail. This coefficient of static friction may be, with an excellent condition of the wheel and rail, as high as 30 per cent.; with good conditions and with the aid of sand, 25 per cent.; with good conditions without sand, 22 per cent.; while on a slippery or icy rail it may fall to 8 or 10 per cent. If this value of the coefficient of static friction is  $n$ , and the value of the driver weight upon the rail in pounds is  $W_a$ , then the limit of the tractive force is  $nW_a$ .

By the term maximum tractive effort at low speeds is meant that force at the engine draw-bar that a locomotive is capable of exerting while at the same time sustaining full boiler pressure. Maximum tractive effort can only result under the combined conditions of full boiler pressure, long cut-off, wide open throttle, and low speeds. The low speeds generally have an upper limit ranging from 5 to 10 m. p. h.. This upper speed limit is dependent upon the ratio of boiler capacity to cylinder capacity, that is, the maximum tractive effort is applicable to a speed where the cylinders have a demand less than, or equal to, the boiler capacity. For relatively small cylinders, the speed may reach 9 or 10 m. p. h., for relatively large cylinders the speed may reach only 4 or 5 m. p. h.

The maximum tractive effort for two cylinder simple locomotives, neglecting the engine friction, is:

$$T. E. = \frac{(m. e. p.) d^2 S}{D} \dots \dots \dots (1)$$

Where T. E. = Tractive effort.  
m. e. p. = Mean effective pressure.  
d = Diameter of the cylinder.  
D = Diameter of the driver.  
S = Stroke.

For general purposes the mean effective pressure is considered 92.5 per cent. of the boiler pressure (P) and the engine efficiency about 92 per cent. Making these additions equation (1) becomes

$$T. E. = \frac{0.85 P d^2 S}{D} \dots \dots \dots (2)$$

Formula 2 is used to determine tractive effort at low speeds unless it gives results that are greater than one-fourth the weight on drivers, in which case the latter value of  $\frac{1}{4} W_a$  is used.

## MAXIMUM TRACTIVE EFFORT AT HIGH SPEEDS.

In the preceding discussion of tractive effort at low speeds, there is assumed to be ample boiler capacity for supplying steam, but as the speed increases, the cylinders demand more steam per unit of time until the cut-off must be shortened in

order to maintain boiler pressure. Evidently the capacity of the boiler has been reached and is the limiting feature in tractive effort at high speeds.

Methods for the determination of maximum tractive effort for simple locomotives at high speeds have been proposed by many experimenters, chief among whom is Dr. W. F. M. Goss, who proposed the following formula:

$$T. E. = \frac{161 H}{V} \dots \dots \dots (3)$$

Where T. E. = Tractive effort in pounds on level track.  
H = Heating surface in square feet.  
V = Velocity in miles per hour.

In equation 3 it is assumed that any locomotive boiler can develop an actual evaporation rate of 12 lbs. of water for each square foot of heating surface per hour, and that 28 lbs. of steam are required per I. H. P. Hr.

In the formation of equation 3 there are three points to which the writer wishes to call attention and, in a way, to make corrections for them in the development of a new equation for tractive effort at high speeds. These points are:

First: The assumption that a fireman always possesses the strength and ability to fire any locomotive boiler at the rate of 12 lbs. actual evaporation per square foot of heating surface per hour.

Second: The assumption that the thermal value of the coal fired is always the same.

Third: The assumption that at all speeds the steam consumption per I. H. P. H. is constant.

In other words, it is the intention of the writer to develop a formula for tractive effort at high speeds, and instead of basing such a formula on the heating surface only, it will be based on the performance of the fireman, the heating surface, the rate of evaporation, and the steam consumption per I. H. P. H. as variables. Points 2 and 3 above were discussed in the *Railway Age Gazette* for March 22, 1912, page 685, and the results given were based on long periods of sustained operation,

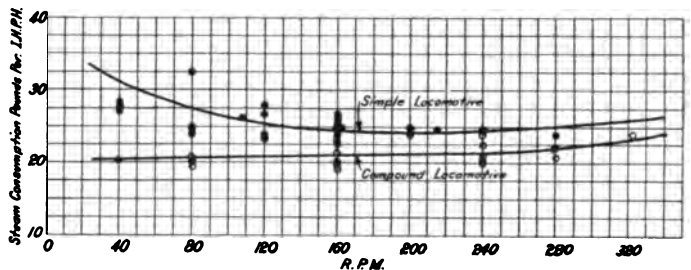

Fig. 1—Steam Consumption per I. H. P. H.

which seem unreasonable for typical American practice where the average profile of the railroads is rolling, requiring sustained operation for short periods only. For this reason the steam combustion curves shown in Fig. 1 were drawn, the data being taken from the results of tests made at the St. Louis Exposition, at the Altoona testing plant of the Pennsylvania and at Purdue University.

Owing to the fact that the tests at low speeds are made with considerably less than maximum power, the steam consumption curve for simple locomotives has not been drawn through the plotted points, as an attempt has been made to have it representative of maximum working conditions. The water rate for

simple locomotives as shown in Fig. 1 may be represented by an empirical equation,

$$S = 34.0 - 0.1 R + 0.001 \frac{R^2}{4}$$

Where S = Pounds of steam consumed per I. H. P. H.  
R = Revolutions per minute.

For compound locomotives there is not the variation in the water rate that there is in the case of simple locomotives, as is shown by the curve, and it would seem that a constant water rate of 21 lbs. could be used as representing the average value, without introducing any material error.

From an analysis of the results of the above mentioned locomotive tests the curve shown in Fig. 2 was drawn showing the fair value of a maximum rate of equivalent evaporation per sq. ft. of heating surface for any locomotive that may be expected from coals of different heat values. These rates of maximum

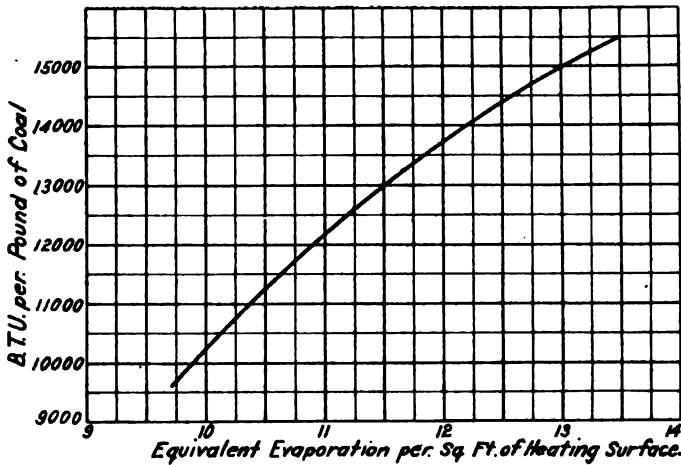

Fig. 2—Maximum Rate of Equivalent Evaporation for Various Coal Heat Values.

evaporation may be expected from any locomotive boiler working to a maximum, under ordinary conditions of the road, with a normal ratio of heating surface to grate surface, and economical firing. It is here assumed that the required rate of firing the fuel is within the limits of the fireman's strength. From these results an average ideal locomotive has been assumed. This engine has a maximum rate of equivalent evaporation of 12.89 lbs. per sq. ft. of heating surface per hour, for 2,700 sq. ft. of heating surface, with ratio of heating surface to grate surface equal to 61, thereby requiring 4,730 lbs. of coal having a thermal value of 14,850 B. t. u. to be fired per hour.

The power developed by a boiler is proportional to the rate of evaporation, the rate of evaporation is dependent on the proportions of the boiler and the amount of fuel which the fireman can handle economically. If a coal of high thermal value is used to increase the evaporative efficiency of the boiler, thereby making it possible to evaporate more water for each pound of fuel consumed, then the boiler may be forced to its maximum power. Of course, if this causes a firing rate too high for the fireman, and it is desirable to retain this maximum evaporative efficiency, then it becomes necessary to resort to some method of mechanical stoking.

With the modern locomotive where the heating surface is very large, and with a normal ratio of heating surface to grate surface, it is impossible for the average fireman to hand-fire such a locomotive up to the maximum rate of evaporation; especially is this so if the fuel is not of high thermal value. In such a case the limit on the output of power is found not in the proportions of the locomotive, but in the strength and ability of the fireman.

FORMULA FOR MAXIMUM TRACTIVE EFFORT.

It is evident that the work developed in the cylinders of a locomotive is equal to the work available at the draw-bar, pro-

vided that there are no frictional losses between these points. Then this may be represented thus:

WORK (in the cylinders) = WORK (at the draw-bar)  
 or I. H. P.  $\times$  33,000  $\times$  60 = D. B. P.  $\times$  distance traversed in feet per hour  
 = D. B. P.  $\times$  5,280  $\times$  velocity (V) in miles per hour  
 or D. P. B. = T. E. =  $\frac{I. H. P. \times 33,000 \times 60}{V \times 5,280} = \frac{375 \times I. H. P.}{V}$  (4)

Now, if  
 E = Maximum rate of equivalent evaporation per square foot of heating surface per hour,  
 e = Maximum rate of actual evaporation per square foot of heating surface per hour,  
 S = Actual steam consumption per I. H. P. H., pounds,  
 H = Number of square feet of heating surface (fire side). (For super-heater engines let 1 sq. ft. of superheating surface be equivalent to 1½ sq. ft. of water heating surface.)

Then H. P. =  $\frac{e \times H}{S}$

Since the evaporation rate is generally given in terms of equivalent evaporation from and at 212 deg. F. it seems advisable to put e in terms of E. This may be done in the following manner, if we assume a boiler gage pressure of 200 lbs. per sq. in. and a feed water temperature of 60 deg. F. Let F equal the factor of evaporation, then

$e = E \times \frac{1}{F}$

Now, F = 1.2069 for a feed water temperature of 60 deg. F., and 215 lbs. absolute pressure. Therefore, for average conditions

$e = \frac{E}{F} = \frac{E}{1.2069}$

By substitution

H. P. =  $\frac{E \times H}{1.2069 S}$  (5)

Substituting the value for horse power in equation 5 in equation 4, we have

T. E. =  $\frac{310.7 \times E \times H}{V \times S}$  (6)

Formula 6, which is a general formula for steam locomotive tractive effort, will serve as a basis for all calculations pertaining to locomotive tractive effort as treated in this article.

On the same basis on which Fig. 2 is estimated, the following table is presented, showing different areas of heating surface which, under maximum rates of evaporation when fuel of any thermal value is used, require the accompanying pounds of coal fired economically:

TABLE VI.

When heating surface is equal to:	Pounds of coal that must be fired per hour.
2,700 sq. ft.	4,730
3,000 sq. ft.	5,260
3,500 sq. ft.	6,120
4,000 sq. ft.	7,000
4,500 sq. ft.	7,880
5,000 sq. ft.	8,760
5,500 sq. ft.	9,640
6,000 sq. ft.	10,520

When B. t. u. value of coal = 14,850 and rate of equivalent evaporation = 12.89 lbs., or, when any other pair of values given in Fig. 2 are used.

For example, suppose a locomotive has 3,500 sq. ft. of heating surface, 80 in. driving wheels, and is to be fired with a coal having a thermal value of 13,000 B. t. u. per pound. To find its tractive effort at high speeds; first, by Fig. 2 it is found that a fair value for the maximum rate of equivalent evaporation per square foot of heating surface per hour is 11.5 lbs. And in Table VI it is found that 6,120 lbs. of coal must be fired per hour. If the fireman can fire at this rate, then it is simply a question of substituting in equation 6 the following values:

E = 11.5  
 H = 3,500  
 S = 34.0 - 0.1 R + 0.001  $\frac{R^2}{4}$

If a coal of different thermal value is used, then the value of E will change correspondingly.

Now, if we again take the above example, and limit it to the fireman's performance by saying that a certain fireman can only fire 5,000 lbs. of coal per hour, then 6,120—5,000 or 1,120 lbs.

of coal are not fired in each hour. In such a case, we cannot expect 11.5 lbs. as a maximum value of  $E$ . But, if we take of 13,000, we obtain the thermal value of an equivalent coal, which gives the same rate of evaporation corresponding to the thermal value given in Fig. 2 as that portion of the original coal which is actually fired. This correction is necessarily due to the incapacity of the fireman to handle the entire weight of coal given in Table VI. Now,  $\frac{5,000}{6,120} \times 13,000 = 10,620$ , which is

the thermal value of this equivalent coal. Then from Fig. 2 the maximum rate of equivalent evaporation is 10.18 lbs.

To find the tractive effort of this locomotive when limited by the performance of the fireman, it is only necessary to substitute in equation 6 the following values:

$$\begin{aligned} E &= 10.18 \\ H &= 3,500 \\ S &= 34.0 - 0.1 R + 0.001 \frac{R^2}{4} \end{aligned}$$

Dr. W. F. M. Goss, in his "Locomotive Performance," arrives at similar conclusions when he expresses cylinder horse power in terms of heating surface. The results of his tests at Purdue University justified him in using 28 lbs. of steam per I. H. P. H., and an actual evaporation rate of 12 lbs. of steam per square foot of heating surface per hour. Then as many horse power are delivered per square foot of heating surface as are expressed by the ratio of 12 to 28, or 0.43, that is:

$$I. H. P. = \frac{12}{28} \times H. S. = .43 H$$

and as previously shown,

$$T. E. = 375 \frac{I. H. P.}{V}$$

By substitution,

$$T. E. = \frac{375 \times 0.43 H}{V} = \frac{161 \times H}{V} \dots \dots \dots (7)$$

This formula gives values which are about 11.2 per cent. higher than those which are obtained by the use of formula 6. The proof of this statement is based on the assumption that 25 lbs. per I. H. P. H. steam consumption is sufficiently accurate to be taken as constant (see Fig. 1), and that the steam which is generated is subject to the requirements of the cylinders only, as the air pump and safety valve generally do not operate to any great extent when the cylinders are working. The water rate for the average locomotive using saturated steam is from 22 to 30 lbs. per I. H. P. H., and for superheater locomotives this amount may be safely reduced 18 per cent.

In the tests made at Purdue University and published in "Locomotive Performance" by Dr. Goss, a coal was used which had an average thermal value of 13,000 B. t. u. per pound. Therefore, a reduction of formula 6 to the terms found in formula 7 for purposes of comparison necessitates the following substitutions, viz.:

Thermal value of dry coal = 13,000 B. t. u.  
 Steam consumption = 25 lbs. per I. H. P. H.  
 Rate of equivalent evaporation = 11.5 lbs.

(On the assumption that the performance of the fireman is unlimited.)

By substitution in formula 6, we have

$$T. E. = \frac{310.7 \times 11.5 \times H}{25 \times V} = \frac{143 H}{V} \dots \dots \dots (8)$$

The ratio of 161 in equation 7 to 143 in equation 8 gives the proportional increase in values to be expected, which is 11.2 per cent., when equation 7 is used to determine the variation of locomotive tractive effort with velocity. When other coals whose thermal values are lower than 13,000 B. t. u. are burned in the locomotive firebox, the difference in values of tractive effort, when solved by equation 7, will continue to increase in proportion to the changes in the rates of equivalent evaporation. If coals of better thermal values than 13,000 B. t. u. per pound

are fired, then the difference in values of tractive effort, when solved by equation 6, and then by equation 7, will continue to decrease, and the resulting values from either formula will become equal to one another when a coal of 14,950 B. t. u. per pound thermal value is fired.

Therefore, it seems that the use of formula 6, which has a valid derivation and gives more reasonable and more accurate results of locomotive tractive effort at the cylinders than other formulae where the size and speed of the driving wheels, the thermal value of the coal, and the performance of the fireman are neglected, is justified.

### INTERPRETATION OF THE RULES OF INTERCHANGE.

At the recent convention in Minneapolis of the Chief Interchange Car Inspectors' and Car Foremen's Association, the code of rules for interchange as adopted by the Master Car Builders' Association was discussed with a view of determining the correct interpretation of each rule, where there seemed to be any chance of misunderstanding. The following are the important conclusions reached under the various rules:

*Rule 1.* This rule was generally understood to mean that each road should conscientiously give all foreign cars the same care as to inspection, oiling, packing, adjusting brakes and running repairs that it gives to its own cars.

*Rule 2.* In regard to the first paragraph, many roads rely on the inspection of the receiving roads to determine defects, while others make their own inspection before delivering. Both practices have given satisfactory results.

In regard to paragraph *c*, many roads accept the improperly loaded car and transfer the load at the expense of the delivering line rather than turn the car back to the delivering line, thereby getting a more prompt delivery of the freight.

*Rule 3.* The second paragraph of this rule was believed by many to offer protection to the negligent car inspector, and it was thought that better results could be obtained by having this paragraph eliminated from the rules.

*Rule 16.* Under this rule it was believed to be permissible to make as heavy repairs as are required to place the car in good condition up to the extent of combination defects and to charge the delivering line or the owner as the case requires.

*Rule 32.* Under this rule the question of missing brake staffs on cars where they were removed for the accommodation of the lading was considered to be a delivering line defect, for when such cars are received, the inspectors should ascertain whether or not the brake staffs were with the car.

*Rule 35.* The stenciling of cars as mentioned in the third paragraph was taken to mean the date when the cars were rebuilt rather than when they were originally constructed.

*Rule 39.* The word "substitute" for draft timber was taken to mean any of the metal draft gears.

*Rule 42.* It was the consensus of opinion that two broken end posts and two corner posts are cardable defects.

*Rule 43.* Burned flooring or siding not able to be seen from the outside of the car and under the ordinary methods of inspection was considered as a "concealed fire damage."

*Rule 60.* In case of neglect to stencil the date of cleaning the various air brake parts, if those parts are recleaned on account of the date shown by the old stencil, the road performing the first cleaning cannot collect for the work done. In case it is necessary to clean those parts soon after they have been cleaned by another road, a joint inspection should be made to determine whether the road that did the first cleaning or the owner should pay for the second cleaning.

*Rule 68.* It is understood that both wheels mentioned in the first paragraph shall be charged to the delivering company, even if the mating wheel has no slid flat spot.

*Rule 105.* A manufactured article was considered as one that

was not included in the schedule and that would have to be purchased in the open market.

*Rule 120.* While this association appreciated that the rewording of this rule is in accordance with their suggestion, they believed it could be made stronger and serve better the purposes for which it is intended, by insisting in some way that requests for home route cars be given more prompt attention. A motion was passed requesting the Master Car Builders' Association to impress on the proper railway officers, "the importance of all roads throughout the country giving their immediate attention to requests for home route cards or for authority for dismantling cars, as it is found that such home route cards or authority for dismantling is being unduly delayed. This, taken in conjunction with lack of proper storage room, is working seriously to the disadvantage of handling lines. Attention is also called to the fact that, in some cases, when cars reach the owner's line they are not repaired permanently, and it is respectfully recommended that owners give proper attention to such cars rather than permit them to again leave the home line with the same defects in existence."

It was understood that the per diem rates stop from the date of asking for home route cards. It was also understood that the car owner is obliged to pay for putting the car in sufficient repair for home routing.

It was also mentioned that car service *Rule 3*, paragraph F, was soon to be changed to coincide with the new rule.

The following addition to this rule was recommended to the Master Car Builders' Association: "If a car is found to have decayed or worn out parts which constitute an unfair usage combination under rules 37 to 42 inclusive, and if repairs are made without authority from the car owners, a joint evidence statement shall be furnished stating the actual condition of the car in accordance with rule 12, and this statement will be the authority for the company having such car in its possession to make all necessary repairs and to bill the car owner for the cost of repairs, provided these repairs are necessary on account of defects due to ordinary wear and tear. The joint statement is to accompany the repair card, as authority for the bill." This change is suggested in order to facilitate prompt repairing of bad order cars and place the responsibility for these repairs where it properly belongs. Under the present rules and decisions the company having such a car in its possession must write the car owner for authority to repair before any repairs are made. This action results in seriously delaying bad order cars and also burdens the company handling the car with per diem charges which frequently amount to more than the cost of repairing the car.

*Rule 14.* In order to have uniform methods for locating defects, it was agreed to observe the following system for under-frame and superstructure. On behalf of a car, the sides shall be designated right and left from a position facing the car at A end and the sides on the B half of the car shall be likewise designated from a position facing the car at B end.

Car service *Rule 15.* A great deal of trouble has been experienced by improper loading of open cars. An inspection at Chicago disclosed the fact that less than ten per cent. of such cars were loaded in accordance with the rule. It was believed that the shippers should be more carefully informed and be made to live up to the rules. The Chicago Car Interchange Bureau has a printed form requesting authority for reloading such cars which is sent to either the shippers or the delivering road, as the case may be. In some localities it is easier to force the shipper to conform to the rules, and it would be possible in all localities, if all the roads would enforce this rule as they should. It was also stated that box cars should be as carefully watched, as overloading often forces the car doors outside the clearance limits. At Buffalo an average of twelve hundred cars are reloaded per month.

It was stated that much more care should be exercised in placing proper car initials and numbers on repair cards. The yard inspectors are found to give the most trouble. When checked

with work cards, corrections can often be made before much trouble has been caused.

One hundred and sixty-two members were registered and the sessions were well attended. The following officers were elected for the ensuing year: F. C. Shultz, chief interchange inspector, Chicago, president; F. H. Hanson, assistant master car builder, Lake Shore & Michigan Southern, vice-president; S. Skidmore, foreman, car department, Big Four, secretary-treasurer.

## COMPARATIVE SUMMARY OF FREIGHT CARS IN SERVICE.

The tables on the immediately following pages show the number of freight cars in service on all of the important railroads of the country in 1911 and 1912, and in 1900 and 1912. The figures are compiled by a railway officer to whom we are indebted for the opportunity of publishing them. It will be noted that narrow-gage cars are excluded, as well as non-revenue cars, but that cars used to carry company freight are included. The railways are grouped under the heads of New England roads, trunk line roads, Southern classification roads, Central classification roads and Western classification roads.

The tables show the number of cars in service, the number of cars per mile of road, average length of haul, freight cars per thousand freight car miles and per thousand ton miles, the average rate per ton per mile, and the freight cars in service per thousand dollars of freight earnings.

**ARGENTINE RAILWAY DEVELOPMENT.**—The public works committee of the senate of the state of Buenos Aires has approved a bill providing for the construction by the state of a railway system connecting La Plata, Bahia Blanca, Buenos Aires, Sierra Chica, Olavarria, and Mar del Plata and authorizing the issue of \$16,405,000 4½ per cent. bonds for the construction of the lines.

**NEW LINES FOR CHINA.**—The Société Belge de Chemins de Fer en Chine has signed with the Chinese government another important railway contract. It includes a loan of \$50,000,000 to be issued at 5 per cent. for constructing a line beginning near the eastern border of inner Mongolia in the latitude of Peking and running thence south southwestward across the Empire for over 1,000 miles to Cheng-tu in Szechwan. Another contract for almost as important a railway from Lauchow on the southern border of Mongolia, southeast to Kweichow on the Yangtze, was recently given to the same company.

**RAILWAY CONSTRUCTION IN AFRICA.**—The Elizabethville-Kambove section of the Cape-to-Cairo Railway will be in operation, it is stated, this month, upon the completion of two bridges. From Kambove the line will then be extended toward Bukama, the preliminary work on this section now being under way. It is expected that 60 miles of this division will be constructed by March, 1914. The greatest difficulty is the lack of native labor. The Lower Congo-Katanga Railway, which will connect Lower Congo with Katanga, is now being surveyed, and work will be commenced upon the completion of the survey. This line, as originally planned, will cut off from the Matadi-Leopoldville line at N'Dolo at Stanley Pool, thence crossing the Kwango river toward the fourth parallel and the Kasai river toward Djoko Punda below Wissmann falls. It is planned to join the Cape-to-Cairo line at Bukama. The total length of the line is about 1,100 miles, and it is hoped it will be opened to traffic by 1920. Owing to the enormous cost of the line as a whole, the only section to be built at present is the Djoko Punda-Bukama division, inasmuch as Djoko Punda is reached by steamer from Stanley Pool. The Congo-Tanganyika Railway from Kabalo on the Congo river to the exit of the Lukuga river from Lake Tanganyika is considerably more than half completed. Rails have been laid for 97 miles, of which 36 miles were completed since January 1. There remain 67 miles to be built before the lake is reached, but a portion of the grading on this has been finished.

COMPARATIVE SUMMARY OF FREIGHT CARS IN SERVICE ON RAILROADS OF THE UNITED STATES—1911 AND 1912.

Table with columns: Miles, Freight cars, Average length of haul, Rate per ton mile, Freight cars per 1,000 rev. ton miles, Freight cars per 1,000 ft. car miles, Freight cars per ton mile, Freight cars per 1,000 ft. earnings. Rows include New England Roads, Trunk Line Roads, Southern Classification, Central Classification, and Western Classification.

\*1912 operations of Iowa Central included in Minneapolis & St. Louis.

COMPARATIVE SUMMARY OF FREIGHT CARS IN SERVICE ON RAILROADS OF THE UNITED STATES—1900 AND 1912.

Note.—Narrow gauge cars excluded. Non-revenue cars excluded. Company freight included.

Table with columns: Miles, Frt. equipment, Frt. cars, Average length of haul, Freight Cars per 1,000 rev. ton miles, Rate per ton mile, Freight cars per \$1,000 frt. earnings. Rows include New England Roads, Trunk Line Roads, Southern Classification, Central Classification, and Western Classification.

\*1912 operations of Iowa Central included in Minneapolis & St. Louis. † Before consolidation with other companies.

# THE NORTH HAVEN COLLISION.

Details of the Cause of this Disastrous Wreck and Full Statements of Officers as to Preventive Measures Adopted.

The rear collision of passenger trains on the New York, New Haven & Hartford at North Haven, Conn., September 2, in which three sleeping cars were wrecked, was reported in the *Railway Age Gazette* last week, page 427. The final report of the number of persons killed was 21, all of them passengers, and of injured, about 30. Three of the injured are still in a critical condition. The explanation of the cause as given last week was in the main correct, except in the matter of distances. The leading train, second 91, which we shall call 91, ran nearly, or quite past the stop signal, signal No. 23, before it came to a stop. The evidence seems to be conflicting as to whether the rear car had not passed the signal or had gone from 50 to 150 ft. beyond it. The other train, first 95, which we shall call 95, appears to have been running about 40 miles an hour when the engineman came in sight of the flagman, the fixed signal and the rear of the preceding train, all at nearly the same instant. Most of the testimony was to the effect that nothing was visible beyond from 250 ft. to 350 ft. anywhere around the scene of the collision, because of the fog; but an officer of the Pennsylvania Railroad, L. R. Zollinger, engineer of maintenance of way, who was on the leading train, testified that, in conjunction with another passenger, he had made careful note of the distance at which the telegraph poles could be seen, and he said that five poles—that is to say, a distance of 750 ft., could be well seen, and he could discern the seventh pole (1,050 ft.).

The starting of train 91 and its immediate stoppage thereafter appears to have been occasioned, not by a purpose to get the train into the next block section, but by the differing purposes of the conductor and the engineman. The brake on one car had to be bled, or, at least was bled, and as soon as all brakes were released the engineman started. But the conductor desired to call in the flagman, and so he at once signaled the engineman to sound the whistle for that purpose. The distance that the train moved forward in the meantime is estimated variously from five feet to the length of one or two cars. Flagman Murray went back not more than from 100 ft. to 300 ft. and his torpedoes were put on the rail apparently not more than that distance back from the train. The next block signal in the rear was signal No. 25, about 7,350 ft. back. There are no distant signals or indications, and no overlaps. The estimates of the time that No. 91 had been standing before it was struck by No. 95 vary. The longest estimate is six minutes. At the last preceding station, three miles back, No. 95 was recorded eight minutes behind No. 91.

The foregoing details are gathered from the testimony taken before Interstate Commerce Commissioner McChord at New Haven, September 4 and 5. The three members of the Connecticut Public Utilities Commission, Messrs. Higgins, Ford and Hale, sat with Mr. McChord. The questions were asked by Chief Inspector Belnap of the Commission, and there was some cross-questioning by J. F. Berry, of the legal department of the New Haven road. In the following paragraphs we summarize the principal features of the testimony which have not already been covered.

The train dispatcher for this section of the road gave the record of five trains which were run from Springfield to New Haven that morning, of which the two which were in collision were the fourth and fifth. South of Hartford a sixth train, a local passenger, was put in between the second and third. All of the trains lost time on account of the fog and the necessity of slackening speed to read the block signal indications. The six trains passed Wallingford, three miles north of the point of collision, at 6:19, 6:21, 6:32, 6:35, 6:43, and 6:51. According to the station records the last train, No. 95, ran from Meriden, 6

miles, to Wallingford, faster than any of the others. Mr. Belnap estimated the speed at 51 miles an hour, from the record; and the schedule speed was 38 miles an hour.

Shortly before No. 95 arrived at Wallingford, the dispatcher directed the operator at that station to display a stop signal for all southbound trains, for the reason that he had heard that the first one of this succession of trains had not reached Air Line Junction, a telegraph station further south; he feared that possibly there might be a blockade and that it would be necessary to run southbound trains on the northbound track from Wallingford. Soon, however, he heard that the delayed train had reached Air Line Junction and he annulled the order to display the stop signal.

Engineman R. W. Wands, of second 91, told of his experience. He was stopped by signal 83, a few miles after he had left Springfield. The fog was dense and he over-ran the signal a short distance. He made an emergency application of the brakes. He stopped there six or seven minutes. He did not give the whistle signal for the flagman to go out, nor did he call the flagman in. He was again stopped at signal 77, near Hartford, and he made the regular stop at Hartford station. Then he found no signal against him until he got to No. 23. At all of these signals the distance that they were visible was, he estimated, about 200 ft. At No. 23 he over-ran the signal, he thought about seven car lengths (there were 11 cars in the train). He was three or four minutes getting the brakes released, not so long as at signal 83, and then he started, first sounding two blasts of the whistle; but the conductor at once gave a stop signal and he stopped, and called in the flagman. This he did twice, for the reason that the whistle blasts the first time were not very loud. The conductor was on the ground near the baggage car, which was the first car in the train. After calling in the flagman the time that elapsed before the collision he thought was about two minutes. He could not tell how far his train was pushed forward by the collision.

He did not know how far he had moved after he started, before the conductor ordered him to stop; he did not take much notice; perhaps one or two car lengths. Asked if he had trouble in stopping at the signals on this division in very foggy weather he said that he did, very much; and he admitted that he sometimes overran the signals. He considered the system without distant signals less safe than one with distant signals. Asked if the enginemen's objection to a system without distant signals had been reported to the company he said that he understood that the committee had brought the matter to the attention of the officers. This was in June, 1912. He did not know whether anything had been done about it. He had never been disciplined for running past signals, nor had he ever reported a case to his superiors. Asked if there had been surprise checking, Wands did not know; he had heard of such a thing but had no personal experience. Asked how fast he could safely run on that line in foggy weather, he thought not over 10 or 15 miles an hour.

Wands was made engineman in January, 1907; a new book of rules was issued in June of that year, and on this book he had not been examined. However, he had looked the book over and said that the rules were practically the same as in the old book.

Cross examined by Mr. Berry, Wands admitted that the road foremen and other officers had talked with him and had told him always to sacrifice speed to safety. Road foremen had ridden with him several times, but he could not say when or how often.

D. T. Barnfather, fireman with Wands, testified, corroborating in general Wands' testimony as to the circumstances of the trip and the collision. At signal 83 he thought the engineman did



not order out the flagman, neither did he call him in. Approaching signal 23 he did not see it; the first he knew, the engineman applied the brakes in emergency.

Mr. Belnap: "How far do you think you ran by signal 23?"

Mr. Barnfather: "Not over seven car lengths, I should say."

He thought they stopped two or three minutes; then the engineman sounded two blasts of the whistle and started (and was at once stopped by the conductor). Another two or three minutes elapsed before the collision. Barnfather had known of enginemen passing stop signals; had never heard of a report of such things being made

Brace C. Adams, conductor of 91, is 44 years old (not 35 as reported last week). He said that his train ran past signal 83 about half its length; that his flagman at once went back to flag the following train (95); and that the flagman went back until he met 95 and stopped it. No. 95 pulled right up behind his train and stopped; Adams' flagman came back and the train proceeded; No. 95 was standing there when he left. (This statement about the flagman and train 95 was contradicted by later witnesses.)

On stopping at signal 23 Adams was at about the fourth or fifth car. He looked back, and although he could not see the flagman distinctly, he saw enough to show that the man was starting back; but the first positive evidence he had that the flagman had gone back was when he heard the torpedoes explode (it was now daylight). He had not had this flagman on his train before for several weeks, but he had worked with him at times in the past and had repeatedly told him that he wanted "long flagging." Adams thought that the train moved forward only about half a car length before he stopped it by his order.

Asked why he called in the flagman, knowing that 95 was so close, he replied that otherwise he would have got into New Haven without any trainmen, as he would probably be stopped at other signals. He expected the flagman to use his judgment; if he had not come in promptly Adams would not have waited for him.

Conductor Adams, asked if he had had occasion to instruct or censure Flagman Murray, replied that once or twice he had; in one case about two months ago. Adams repeated that he had told Murray that he wanted long flagging. Asked if any officer of the road had been over the road with him as instructor he said no, except that when he first began running as conductor, the trainmaster rode with him on the way freight two days. Asked by the counsel of the road why he had not reported cases where enginemen ran past signals, he had no satisfactory reply. Mr. Berry quoted to him the rules, including one which empowered the conductor to suspend a man if necessary in case of violation of rules. Adams acknowledged that he knew all these rules.

C. H. Murray, flagman of No. 91, is 23 years old. He has been in the service since September 26, 1912, or a little less than one year. He was employed first as spare freight brakeman at Holyoke, Mass., on the Northampton division. He testified that he did not go back to flag at signal 83, as was said by Conductor Adams; he never saw train 95 until it struck his train at signal 23. In this Murray was emphatic. He was subsequently corroborated by other witnesses.

Shortly before the stop at signal 23, Murray saw Adams on the platform of the next to the last car, but did not speak to him; he does not know that Adams saw him. When the train stopped at signal 23 he got off and walked back; asked about signal 23, he said that he did not see it; never noticed it; he was pretty sure that it was not ahead of him, for he looked ahead and did not see it, although he was on the right side of the train to see it. When he put down the torpedoes he was near enough to the train so that, notwithstanding the fog, he could see a porter wearing a white coat, standing near the rear car. After putting down the torpedoes and starting back for the train, in response to the whistle signal, he heard train 95 coming and started to light a fusee, but he did not have time to do so and started north

running and swinging his red light; but the train was upon him before he had done anything effectual. When train 95 came to a stop after the collision its rear car had not passed Murray; he could not tell exactly where he was; he at once ran forward. After running a short distance he climbed up on to the rear platform of the baggage car to reach the other side of the train.

He did not remember that any conductor had ever reprimanded him for poor flagging or ever had instructed him as to his duties. He said that in testifying on a previous day, before an officer of the road, to the effect that he had gone back six or seven telegraph poles he had been mistaken; it must have been considerably less than that. Murray had no watch.

Cross-examined by Mr. Berry, Murray said that he knew the flagging rules perfectly; he also admitted that he had been talked to by Trainmaster Regan and that he had been called to account for forgetting to put the markers on his train on one occasion. He professed not to remember definitely anything which had been said by the trainmaster.

It appears that flagmen who run on freight trains are required to take a more thorough examination than other flagmen, because of the liability that they may have to act for the conductor, at times, when the conductor is at the forward end of a long train. Murray's statement that he had not taken this examination made it appear that he was not a "qualified flagman."

F. L. Bunday, baggageman of second 91, looked out at the side door when his train stopped at signal 23, but he could not see the signal; neither could he see the rear end of the train; he did not know whether the train was entirely past the signal. He judged that the stop lasted about five minutes in all. When the train started it moved about the length of half a car, he estimated. The conductor, standing on the ground two or three cars back, shouted to call in the flagman and Bunday repeated the order.

S. F. Evans, chairman of the Locomotive Engineers' Brotherhood, presented the correspondence which had been had between himself and the general superintendent in August, 1912, when the several divisions of the brotherhood protested against the use of block signals of any kind without a distant indication. The men on the Hartford division first formulated the complaint and then those on other divisions endorsed it. The general superintendent sent a reply, calling attention to the fact that all of the enginemen knew the road, knew where the signals were located and knew the rules about observing them. To the charge that discipline had been drastic and unreasonable he replied that the number of cases of dismissal or discipline of any character for disregarding signals, in the territory referred to, had been very small—probably not more than one case in the past year; and he said that practically all of the cases where signals had been overrun had occurred at points protected by distant signals. He enlarged on the fact that the New Haven road had made a good record of freedom from accidents to passenger trains, which could not have been possible with poor appliances.

In a subsequent letter Mr. Evans, supporting his charge of unreasonable discipline, said, "If any of our men do not take these chances and make the time there is a continual prod after them every day they do not make it, and it is one of the things that I hear almost every day from the men, saying they got letters from the superintendent that they lost a minute or more, and in some cases they are told that they will not stand for any loss of time; the other men make it and the time has got to be made."

Engineman August B. Miller was the first witness Friday afternoon. Miller gave his age as 47 (not 27, as previously reported). He said he had been an engineman since July 14, 1903. Of the 77 block signals between Springfield and New Haven, 62 miles, he thought that only about a dozen had distant signals or distant indications. Asked what his experience had been on this division in foggy weather, he replied, "I have

had very good luck. We have had considerable foggy weather in the last 10 days and I have been cautious, and I have been unusually fortunate to stop at my signals." He has run on this division about eight or nine years. He had been on this train regularly about two months. It is a summer train. (Miller here gave the times as they are shown in a table which is given on our editorial page.) To Mr. Belnap's question if he had opportunity to sleep from nine o'clock Monday morning until ten o'clock Monday night, he replied: "Yes," but modified this by saying that he was ordered out of the house at 9 p. m., leaving 12 hours for sleep.

Mr. Belnap: "So that each time you went to Stamford, you got 12 hours sleep?"

Mr. Miller: "Yes, sir."

Mr. Belnap: "And you had time for two or three hours' rest at Springfield each trip?"

Mr. Miller: "Yes, sir."

Asked about the condition of the air brakes on leaving Springfield, he said that they were reported to him all right; but on further questioning recalled the fact, which he had forgotten, that the baggage car had no air brakes. On this car the brakes had had to be cut out because one brake beam was out of order. This left Miller with six cars braked and one unbraked.

Recounting the trip, Miller said he was stopped first by a signal in the Springfield yard; he thought the stop was about five minutes. The next stop was at Hartford.

Mr. Belnap: "Weren't you flagged and stopped at signal 83 by the flagman on the rear of train No. second 91?"

Mr. Miller: "No, sir."

Mr. Belnap: "Didn't you see second 91, and stop behind it?"

Mr. Miller: "No, sir."

Miller found signal No. 25 clear. He called the signal to the fireman. It was visible, he thought, about 200 ft. At signal 23 he estimated the length of the view about the same.

Mr. Belnap: "You expected, of course, to find signal No. 23 clear?"

Mr. Miller: "I certainly had no other idea. . . . The first thing I saw was the flagman and I had no more than seen the flagman before I struck the torpedoes; I looked up and saw I had my banjo against me, and the rear end of that train ahead of me."

Miller estimated that the flagman was about 90 ft. back of the train and about 45 ft. back of the signal. The torpedoes, he thought, were 45 ft. back of the flagman. The flagman stood in the ditch, swinging a flag crosswise. Miller had no time to jump and had no thought of any such thing. Miller at this point, answering further questions, told of his time off at Stamford on the day before the collision, giving the facts as shown on our editorial page. He said that he arrived at his house at 11:30, ate his dinner and got to bed about 12 o'clock. He slept four hours and a half at home and lay down about two hours at Stamford in the evening. (The record of the testimony at this point indicates that Miller stated that this was his regular daily routine; but on the next day, from his further statements, it appears that this was the case only when he was running every day, which was only for a week preceding the collision. Prior to that time he ran only every other day, and spoke of the "long days" of rest.)

Mr. Belnap: "Were you in any way sleepy on that trip?"

Mr. Miller: "Not at all; no, sir."

Mr. Belnap: "You are certain that signal 25 was white?"

Mr. Miller: "I am."

Asked if he had ever overrun signals, he recalled one case nine years ago. Asked if he had a collision at that time, he replied that he thought not. Mr. Belnap, quoting from the records, asked about a case in February, 1911, but Miller said that on that occasion he had run past a signal because the brakes did not hold. This was a freight train, and there was a collision. Asked how he could account for his over-running at signal 23, after such a good record, he replied: "It was on account of the

fog. There was no stated point where that signal was. I had no stated mark to look for and, on account of the fog being so heavy, it was hard to distinguish the exact point where it was." From Meriden to Wallingford he judged that he was running about 35 to 40 miles an hour. "Would you be surprised if the train sheet showed that you made 51 miles an hour?" "I should, sir, be very much surprised." The schedule of train 95 averages 38 miles an hour over the division. Miller, in answer to a question, thought that he could run 40 to 50 miles an hour in foggy weather and be prepared to stop at every signal.

Mr. Belnap: "Do you think that the system of signalling would be much safer if it had a caution indication?"

Mr. Miller: "If you had had a caution indication there, you gentlemen would not be here."

Miller had run over two torpedoes at Meriden freight house. He did not know how these came there, but there was a freight train standing on another track at that station doing work.

On further questioning, Miller thought that with dense fog all along the road he should not try to make more than 25 or 30 miles an hour. His previous higher estimate was based on the assumption that at some of the signals he could get a better view. Miller had never reported the unsatisfactory condition of the signals, but knew that the brotherhood had made a complaint (referred to above).

Mr. Berry, on cross-examination, brought out the fact that since February, 1911, Miller had had a clear record. Miller acknowledged having attended a meeting at the superintendent's office on the day previous to the Stamford collision, where enginemen were enjoined to be strictly careful and try to run trains safely over the road. "And I have tried faithfully from that day to this to live up to the rules."

The records being read by Mr. Berry, Miller recalled interviews with Foreman Buckley, Road Foreman Burke and Road Foreman Daily. Road Foreman Buckley had ridden with him; he could not recall the date. It was sometime in August. After one meeting at the superintendent's office the superintendent talked with Miller separately. Miller recognized a safety circular which had been issued by the superintendent on August 29.

Miller could remember only two occasions when road foremen of engines had ridden with him; one of these was when the new engines were put into service, a few months ago.

Elbert A. Robertson, Miller's fireman, 31 years old, in service 27 months, testified that signal 25 was clear and that the engine-man called it to him and he answered. He thinks he saw the rear of the standing train, No. 91, before the torpedoes exploded. In foggy weather Robertson had known of numerous cases of running past signals short distances—from 2 to 6 or 8 cars. Cases of this kind may have occurred as often as once a week. He testified to being a regular passenger fireman on this section of the road, but his statement concerning over-running does not show what train he was on or what engine-man he was with. Robertson had never been examined on the book of rules and had not been required to carry a watch; he had, however, received a book of rules. He had been examined as to eyesight and hearing. The representative of the company who employed him thought that instructions were unnecessary because of his previous experience; he had been on the New York Central 7 years.

Mr. Belnap: "Did they occasionally run by automatic signals over there the same as here?"

Mr. Robertson: "Yes, sir."

Robertson, in company with Engineman Miller, and Mr. Daily, after the collision, went back and found where the torpedoes had been exploded. The distance from the train he judged was 60 to 70 ft.

Mr. Berry, in cross-questioning, elicited from Robertson a statement that when he came to the New Haven from the New York Central he was familiar with the rules and with automatic signals. Asked about differences between the two roads, he said: "Over there they are working under what is known

as the standard code of rules, while here we are not working under the standard code."

Mr. Berry: "That is to say, the rules are a little bit different?"

Mr. Robertson: "They are a little bit different."

Asked by Mr. Belpap if flagmen properly protected their trains, he replied: "Of late we have not had so much trouble as we did sometime ago. There was a time when we had some young men here who were called 'piazza flagman'; but the trainmasters have been watching them so closely that they have been living up to the rules better of late." Though having known of numerous instances where flagmen did not protect their train, Robertson had not heard that anybody reported these occurrences.

Lambert H. Fowler, conductor of No. 95, has been a conductor 13 years. He testified to the cutting out of the brakes of the baggage car at Springfield, leaving a little over 85 per cent. of the cars in the train braked. He could recall only one or two cases previous to this when brakes had had to be cut out. He thought that at the time of the collision the train was running 35 or 40 miles an hour. After the collision he thought that his third car was opposite signal 23. He had not stopped at signal 83. He thought that he could see from 300 to 350 ft. in the fog. His last examination on the book of rules was about two years ago. He remembered not more than two or three times where an engineman had run past a signal, and then not more than one or two car lengths.

Edward A. Kitchen, front brakeman of No. 95 testified to going ahead and stopping a northbound train. He thought that he could see through the fog perhaps five car lengths. Kitchen had been examined on the book of rules when promoted from freight to passenger service. Asked about the difference between a trainman and a flagman, he said there was none in the passenger service. In the freight service a flagman is the next grade above a trainman and below the conductor, but in the passenger service the baggage master is in that position.

L. R. Zollinger, engineer of maintenance of way of the Pennsylvania Railroad, who was a passenger on No. 91, testified concerning the fog. Meeting a friend who had been on the other train, he went with him back and observed the telegraph poles. They could clearly distinguish the cross arms on the fifth pole; could see the sixth pole and the outline of the seventh, though not near the ground, the fog being thicker for about two feet from the surface of the earth. This was about eight minutes after the wreck. Afterwards the fog became a little thicker, but even then he could distinguish the seventh telegraph pole, which was certainly 1,000 ft. from him. Mr. Zollinger took his observations on the east side of the train and had taken no notice of signal 23 at that time. He did not measure the distance of the telegraph poles from one another, but said it was at least 150 ft.

H. A. Clark, car inspector, testified about the broken brake beam on the baggage car when it was delivered to the New Haven by the Boston & Maine at Springfield. He could not have put in another brake beam without taking the car to the yard, some distance from the station, as the train at the station was standing on the main track of the Boston & Albany. It would have taken at least an hour to put in a new brake beam. Asked if there had been any change in the methods of inspection since the Stamford collision, Clark replied that more attention is now paid to the triple valves and to piston travel on all cars. A record is kept of all inspections of this kind, so that the piston travel on any car at any time can be known. As to repairing cars received from other roads, if the work can be done in five or six minutes, it is done; otherwise, if not serious, the air is cut out, and if necessary to maintain 85 per cent. of braking power, the car is cut out.

D. W. Wildin, mechanical superintendent of the road, testified concerning mechanical details. He has been mechanical superintendent on this road six years. The inspection rules allow trains to be run if they have 85 per cent. of the cars air

braked. The baggage car of No. 95 was an important car, containing as it did all the baggage of the passengers on the train. This was the first instance that he recalled since the records had been kept in which brakes had to be cut out on a passenger train.

J. A. Droege, superintendent of the division, testified concerning discipline and other general conditions on the division. He has been here since December, 1912, and prior to that was superintendent of the Providence division for nine years. The daily average number of passenger trains northbound between New Haven and Springfield in the month of August was 19.5; southbound, 18.8; freight trains, 8.1 northbound and 8.0 southbound. The trainmasters and the men designated as examiners, examine every new man as soon as possible; except in extreme emergencies a man must be examined before he is put to work.

Referring to the matter of examinations, Mr. Droege said that the term "qualified flagman," as used by a previous witness, meant that such a man was qualified to act in emergencies as conductor. The trainman who testified meant to say that he had not thus been examined concerning a conductor's duties. All trainmen, both freight and passenger, are qualified as flagmen when they enter the service. There is no rule requiring flagmen to have watches. No conductor shall go out with more than one inexperienced man in his crew. As to re-examination of men, the records prior to Mr. Droege's taking this position are imperfect. At present five men are at work examining all of the trainmen whose names do not appear on the record as having been examined within a reasonable time. Asked about watches, Mr. Droege said that the company did not insist that flagmen should carry standard watches. There is a rule requiring conductors, enginemen and brakemen to compare watches; but this is not intended to apply strictly in a case where the flagman's watch is not a standard watch. The trainmasters, as they go over the road, ask flagmen if they have watches; but they do not require these to be standard. The superintendents question the men in the same way; Mr. Droege had never encountered a flagman who did not have a watch.

Mr. Droege has eight trainmasters and assistant trainmasters; territory 440 miles; number of men in train service about 2,600. The trainmasters ride over the road to investigate and instruct the road foremen of engines.

Commissioner McChord: "Do you think that is a sufficient number?"

Mr. Droege: "Well, I should say it was."

Commissioner McChord: "Here is an instance of this young man; you never knew whether he had a watch or not. This is a small matter, but what we are trying to find out is what discipline you have. If you lack discipline in little things you are likely to overlook it in big things."

Questioned about overrunning of signals Mr. Droege said that very few cases had been reported.

Mr. Belpap: "What about these cases spoken of at this hearing as occurring so frequently?"

Mr. Droege: "I don't know anything about the cases that we don't know about."

Questioned about inspections, Mr. Droege said that the trainmasters and road foremen went out on the road, and also the officers had talked to the men and cautioned them; also had watched train movements. Mr. Droege agreed that automatic signals were safer with distant indications. Asked how long he had been of that opinion he replied: "Since I was old enough to know anything about the signal situation." The installation of distant signals between New Haven and Springfield was ordered soon after Mr. Droege came to this division.

Asked about the practice generally on the road in regard to checking obedience to signals, Mr. Droege said that he could answer only as to his own work. When he came to this division he at once called a staff meeting and urged his officers to get out on the road as much as possible; impress the men with the importance of observance of rules; take care never to urge any engineman to run faster, or to question him about his speed

either by word of mouth or in writing; to instruct train despatchers to make record of every irregularity. He thought that these injunctions had been vigorously carried out. On March 10 another staff meeting was held and orders given to interview all of the enginemen. Another meeting was held on April 6 and the same subject again gone over. Staff meetings also were held on June 2, June 9, July 21 and August 25 for the same purpose. Also 12 or 15 meetings were held with enginemen and conductors at division terminals. Mr. Droege himself had personally interviewed between 150 and 200 men. The trainmasters were instructed so as to insure that their talks to the men should be uniform. A list was made of all conductors and enginemen against whom there were questionable things on their records and these were spoken to individually. Engineman Miller was one of these—though his record had been clear for two years and six months. Miller, and one other man interviewed at the same time, "were in a receptive mood and took the admonitions in good part; they promised without hesitation that they would do the best they could, and I believe they meant it. In that talk, as in all others, I invariably laid emphasis on the question of signal observations, and told the men that in cases of difficulty in reading signals, or finding a signal, whether in foggy or stormy weather conditions, or for any other reason, that all they had to say was they lost time because of their difficulty in reading the signal, or finding and locating signals, and I said there would never be any question raised; and I don't believe there has been any question raised with any man who reported delay for that cause. I used the expression, I remember it, 'If necessary, they should anchor there until they knew what the signal position was.' I didn't care how slow they had to run or how long they stayed there; and to support my statements as meaning what I said, I can refer to any number of cases where men have lost on that Springfield line all the way from two minutes to thirty, on a run, ascribing it to fog, and there never has been a question with them, so far as I know. In fact, I have asked the enginemen, in meetings afterwards, whether they were being criticized. In a few cases they said the question had been asked, 'What caused the delay?' but nothing beyond that. The trainmasters talked to them on the same lines."

Asked if anybody had gone out to see whether these instructions were obeyed, Mr. Droege replied that everybody was out as much as possible. He himself had spent all the time he could on the road. He believed the general performance of enginemen had been very much better than a few months ago; also there had been fewer cases of poor flagging. There are too many cases of signals being overrun, but he believed that this record was the result of requiring more faithful reports than had been required in the past. He had discharged an important transportation officer a few months ago because he did not report a case of overrunning of a signal which he had known of. Asked further about discovering delinquencies Mr. Droege said that in addition to the inspections "we get a good many reports from a large number of the men who are sufficiently honorable and conscientious to report those things, to keep other men out of trouble."

Mr. Berry here put into the record the circular of August 29 which had been referred to in the examination of Miller, and also a circular issued on June 1.

Answering a question of Commissioner Higgins, witness said that Flagman Murray had been assigned to his position by Trainmaster Regan.

Edward E. Regan, trainmaster on this section of road, gave testimony concerning the selection of men. He has been trainmaster two years, and before that was assistant trainmaster two years, and prior to that assistant general yardmaster at New Haven; had been clerk and stenographer and chief clerk to the superintendent. He had never been examined on the book of rules.

Trainman Murray had been assigned by Crew Despatcher Doolan. Murray was examined on the rules by Messrs. O'Neil and Jolson, the regular examiners. Replying to a question from

Mr. Berry, Mr. Regan said that men for the passenger service were recruited mainly from the freight men and the yard men. For the passenger service this summer Regan had taken about 100 men out of the freight service. Regan had talked with Murray three times. He could not recall precisely what he had said; he could only give the substance of what he made it a rule to say in all such interviews. He had emphasized particularly the matter of protecting the train when working as rear flagman. He endeavored to impress on the men that they must do well so as not to be called into the office to be criticized. Murray had been called in twice, once in June and once in July, for minor infractions of the rules. Regan considered Murray a good man; otherwise he would never have transferred him to the passenger service. Asked if he had ever discharged flagmen for failing to flag he replied: "Very many; have discharged, suspended, disciplined and demerited."

Asked about the examiners, Regan said that O'Neil had been in the service 10 years and Jolson about eight. It did not appear that they had ever been either train despatchers or in the train service. Only one inexperienced man can be employed on a train; a man having less than six months' experience ought to be classed as inexperienced. New men generally go over the road for six or eight days on the local freight to learn the work and then they have to bring a written certificate from the conductor with whom they ride.

Clinton L. Bardo, general manager, gave testimony concerning discipline, supplementing Mr. Droege's statements. Mr. Bardo has been general manager since February 15, last, and prior to that was assistant general manager of the Lehigh Valley for about two years; before that he was for four years superintendent of the Grand Central Terminal, New York City. He started to give the records of the men connected with the trains in collision but was stopped and directed to hand this matter to the commission in writing, later. He gave a summary of cases of discipline for over-running signals since January 1, 1911. On the whole road there were 158 cases, of which 62 were on the Shore Line division (in which the New Haven-Springfield line is included). In connection with these 158 cases, 32 enginemen were discharged, 117 were disciplined by suspension or other means, and 9 cases were disposed of in some other way. In three of these cases the engineman was killed. In the same length of time 101 men had been disciplined for improper flagging, of which 38 cases were on the Shore Line division. Twenty-eight men were discharged and 73 were otherwise disciplined.

Mr. Bardo described briefly the organization of a division. Each division superintendent has a staff meeting every week, at which are present all the heads of departments, including the mechanical men. Discipline of any man is administered mainly by his immediate superior officer. The Brown system, somewhat modified, is in use; was inaugurated about 1905. Mr. Bardo seriously questioned whether this is just the right system for the service on this road; "but we have it and probably will have to get along with it." The superintendent knows at all times what the trainmasters are doing and where they are. Asked whether or not the signals on the line in question would be safer if each one had distant indication, Mr. Bardo replied, "Well, coupled with the rule that we have, I should say no."

Mr. Belnap: "In what way do you expect that a rule will neutralize the effect of the failure of men to obey?"

Mr. Bardo: "The engineman would disregard the rule if there were a distant signal, just the same as if there were no distant signal. We have such cases just the same where we have distant signals. The only thing involved here is the disregard of two very simple principles, (1) protect your train, (2) observe the rules."

At this point Commissioner McChord referred to the enclosed disk signal as obsolete, remarking that he understood that only 224 miles of road in this country now had such signals.\*

Mr. Bardo said that "the system" was not the best in use to—

\*The report of the Interstate Commerce Commission for January 1, 1913 shows 1,705 miles of road (3,615 miles of track) equipped with enclosed disk signals.—Editor.

day; but, coupled with the rule, it was as safe as any system, because, "It requires a man to observe only two things, namely, to protect his train, and, if he cannot see the signal, to stop."

Mr. Bardo, like Mr. Droege, had cautioned enginemen to be sure to make safety the first consideration, until the conditions could be improved. "If trains must be delayed why, we will take our medicine." Surprise tests had been made last year, but had been discontinued before Mr. Bardo came to the road; since then there have been so many other things to do that he has not restored those tests, although the matter has been discussed two or three times.

#### SECOND DAY'S HEARING.

The first witness on Friday was Frank T. Shanley, brakeman on 91. Shanley entered the service last May, before he was 21 years old. On stopping at signal 23 Shanley assured himself that Murray had gone back. When the collision occurred, Shanley was standing at the front end of the last sleeping car. Shanley's testimony seems to indicate that the rear of train 91 had passed signal 23 about two car lengths, but it is not very clear. He thought the train moved forward, before it was stopped by the conductor, only about five feet.

Questioned about his qualifications he said that there was a typewritten note, at the bottom of a page of his book of rules, to the effect that he was qualified to flag in case of emergency.

Shanley thought the stop at signal 83 was about two minutes. He did not know whether the flagman went back. He had no talk with Murray after the accident, except to say, in reply to a question, that he had heard the torpedoes. Shanley had shouted to Murray to jump out of the way of the approaching train. All he could say about Conductor Adams was that at the first stop he had seen Adams releasing the air brakes.

Engineman Miller was recalled on Friday and gave additional details. Signal 25 was clear, "and I gave the engine a little more steam to get to the top of the knoll opposite the gravel pit"; then he shut off and made a 5-lb. application of air; and when he saw the flagman he made another application of about 10 lbs.; and when he saw the signal and the tail end of the train he applied the brakes in emergency. Asked if the brakes took hold he replied, "They certainly did."

At this point Miller asked leave to amplify his statement of the previous day concerning his runs. He said: "It was not a very easy run to cover on account of my living here (near New Haven). A man can't live in three places and do one thing. On account of the job being where it was, I bid it rather than stand on the spare board. A man standing on the spare board will get a call to go [from New Haven] to Harlem River [68 miles] and when he gets to Harlem River he is cut out for eight hours, and then the chances are he is started for Northampton [144 miles], and when he gets to Northampton he is cut out [for the statutory rest period], and then he starts from Northampton to Harlem River again. Sometimes I was away from home for a whole week, living on the railroad track, and I was heartily sick of it, and I bid the first thing I could get. I had quite a number of small jobs and held them as long as I could until I was bumped by an older man. Then I took the White Mountain Express." He went on to give the hours, as we have shown them in another column. (His statement on the previous day to the effect that he has 12 hours off at Stamford seems to have been based on the assumption that he would reach Stamford two hours late, or, say, 9 a. m. instead of 7 a. m.)

On the morning of the collision Miller supposed that the other runner, who had been sick, would resume work, but he was not there, and so Miller said to the despatcher, "All right, I will have to cover it." Continuing, Miller said: "This last week, when I doubled, is what I referred to in my testimony of yesterday. I don't feel as though the company has anything against me; I don't think I have violated any rules; I don't think I have gone without sleep; I have had plenty of sleep and I have not had to take any whiskey to brace me up; that is

something I have never done in my life. I make this explanation so you will not think that I have been running this way since July 1."

Mr. Bardo was again called to the stand, but the questions asked were largely repetitions of matters which had been covered in the examination of Mr. Droege, Mr. Wildin and Mr. Bardo the day before. The 100 trainmen who had to be taken from the freight service for the summer passenger trains, said Mr. Bardo, were necessarily those who had no regular freight runs, or men who had some desire to work on passenger trains. "The best we could do was to make the best selections possible, based on experience, general deportment, habits and personal characteristics." As to putting the best man at the rear of the train, there had been a tendency among the older men to want to get away from the rear end of the train, and it became necessary for the trainmaster to decide this question in each case, and not leave it to the conductor. The trainmaster or the crew despatcher must decide which of the two men shall be the rear end man.

Asked about the ability of eight trainmasters and assistant trainmasters to supervise 2,500 or 3,000 men, Mr. Bardo said that there was other supervision besides this; the large stations and terminals have agents and general yardmasters; the chief train despatchers and the train despatchers supervise trains to some extent, and there are also the road foremen of engines and the division engineers and supervisors of the roadway department.

The book of rules adopted July 1, 1907, made no important changes in old rules.

Mr. Bardo testified to taking action after the collisions at Stamford and elsewhere, similar to that testified to by Mr. Droege. The decision to install semaphore signals with home and distant indications on the New Haven-Springfield line was delayed somewhat by consultations held with the enginemen as to whether they preferred the left hand or the right hand quadrant. The enginemen were unanimous in their opposition to the center suspended signal and in favor of the upper left hand quadrant.

Asked if orders for steel passenger cars had been given and then rescinded, Bardo knew of no such thing. Mr. Bardo, like Mr. Wildin on the previous day, gave full details about the company's orders for steel cars and when they were to be delivered.

Complying with the request of Commissioner McChord, made the day before, Mr. Bardo presented the minutes of a meeting of the board of directors October 17, 1912, when the president of the road was instructed to leave nothing undone which, in the judgment of himself and his associates, would conduce to greater safety, no limitation being placed by the directors on the installation of signals, safety appliances or anything else that in the judgment of the president or his associates would improve the safety of passenger travel. At the same time it was voted that the policy of the company should be that all passenger equipment purchased in the future should be of the all-steel type. Following this Mr. Bardo gave a long list of items of expenditures for steel cars, for signals and for other safety features, since August, 1911, the total amounting to \$6,926,050. A very small part of this expenditure was for replacements.

Supplementing his previous statements in relation to improvement in safety of operation, Mr. Bardo read a letter which he had issued to his subordinates June 5 last and another June 11. In these he called on the general superintendent and the mechanical superintendent to attend to these matters personally and see that the officers of each division should put this matter above everything else; and he called for weekly reports of the action taken on each division.

The number of men who have been interviewed within the last few months is over 8,000. Mr. Bardo presented a pamphlet containing the standard rules for examining men. Commissioner McChord wanted to know why conductors had not been held more strictly to the requirement that they should see that the rear flag-

man stayed on the rear car. Mr. Bardo replied: "We will do anything we possibly can do." Mr. McChord also wanted to know if passenger trains could not be scheduled farther apart, for if these trains on the fatal morning had been running 16 minutes apart instead of eight minutes the collision would not have occurred. Mr. Bardo would not admit this. It would be dangerous to try to combine the time interval with the space interval. Indeed, if 95 had been three minutes behind the engine-man would have found signal 25 red, and the collision would not have occurred. Mr. Bardo submitted a copy of the circular which was issued previous to the heavy traffic of Labor Day, giving in detail the arrangements for all of the extra trains.

Richmond Dean, general manager of the Pullman Company, gave testimony concerning the construction of the sleeping cars which were in the wreck and also concerning the general policy of his company in the matter of building steel cars, with data concerning the number built, the number in service, etc. The Pullman Company had to transform its entire shop to a steel working plant instead of a wood plant and had to educate its men, a great task; but 38.4 per cent. of its active equipment is now made up of steel cars. No wooden cars are being built. The rear car in the wrecked train was built in 1908, the best style of wooden car at that time.

Mr. Wildin gave full details of the steel car equipment of the New Haven road, and C. H. Morrison, signal engineer, testified concerning signaling details.\*

\*The enclosed disk signal, No. 23, referred to in the foregoing account, is of the well known type, wooden case, painted white, with a wide black ring around the central opening through which the disk is displayed. A separate opening above the disk shows the light at night. The signal is about 20 ft. high and stands about 8 ft. from the nearest rail of the track. —Engineman Miller and Trainman Murray were held by the coroner on criminal charges and subsequently were released on bail bonds of \$5,000 each. It was said that Miller's bond was furnished by the Brotherhood of Locomotive Engineers and that Murray's was furnished on the order of the railroad company.

### COMBINATION BRASS, IRON AND STEEL FOUNDRY.

In connection with the new shops at Watervliet, N. Y., the Delaware & Hudson has installed a combination grey iron, brass and steel foundry. The making of even brass and iron castings by railroad companies is believed to be of doubtful economy by

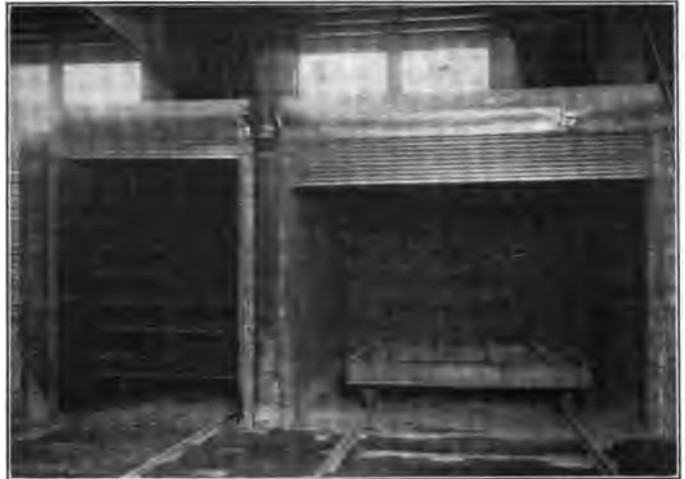

Drying and Core Ovens.

many, but in addition to these this foundry is turning out all the steel castings used in locomotive and car repairs except driving wheel centers and locomotive frames. The mechanical department officers of the road have been much pleased with



General Arrangement of the Interior of the Delaware & Hudson Foundry, Digitized by Google

the results, particularly in the reduction of the time of delivery of castings. When a casting of any description is needed in a hurry it can be molded and delivered almost immediately, eliminating the delays attendant on ordering and shipping from outside sources. Excellent results have been obtained from the steel castings, including driving boxes, and with the means of making these castings so near at hand, it has been found convenient, in



**Battery of Drawer Type, Oil Fired Core Ovens.**

several cases where iron castings have proved of insufficient strength, to replace them at once with steel castings. This often saves delay in getting locomotives out of the shop and if the casting is unnecessarily heavy when cast steel is used it can be redesigned later.



**Arrangement of Cupolas in the Delaware & Hudson Foundry.**

The main bay of the foundry is 57 ft. 4 in. x 176 ft., and is devoted to molding operations. The side bay is 30 ft. x 176 ft., and includes the cupola room, the core room and the cleaning



**Oil Burner Type Annealing Oven.**

room, and also provides space for the steel converter, sand grinder, sand storage, and annealing oven. The blowers are located on mezzanine floors, where toilet facilities are also provided.

The equipment was furnished by the Whiting Foundry Equip-



**Tilting Brass Furnace of 400 lbs. Capacity.**

ment Company, Harvey, Ill. For the melting department (grey iron and steel) this includes a standard No. 5 Whiting cupola of from seven to nine tons capacity per hour, and a cinder mill; a No. 3 cupola is used for melting stock for the converter. The cupolas are provided with roofhoods, spark arresters, bottom door props, lighting torches and positive pressure blowers, with

the necessary lining, blast piping and gates. A full equipment of ladles for both grey iron and steel is of course available and a casting breaker with steel framework, drop weight and electric hoisting machine, and an electric elevator of two tons capacity are also included.

In the steel foundry there is used a Whiting side-blow converter of two tons capacity, with the tipping mechanism operated by a motor; it is fitted with a Roots high pressure positive blower. There is also an oven 10 ft. x 13 ft. 6 in. for annealing steel castings, and a rotary sand grinder.

The coremaking department is provided with a car oven 7 ft. x 17 ft.; a drying oven for cylinder molds, 12 ft. x 17 ft., and a battery of drawer type ovens in three sections. An electric jib crane of four tons capacity is used for handling the cores. These ovens were installed complete with the brick work, flues



Side Blow Steel Converter of Two Tons Capacity.

and stack, and also the core and drying cars. The core and annealing ovens are oil fired, Ferguson burners being used. The cleaning department equipment consists of three exhaust tumblers 36 in. x 60 in., with piping, dust arrester and exhauster; there are the necessary chipping benches and grinders, the latter being connected with the exhaust system.

The brass foundry included a tilting brass furnace of 400 lbs. capacity, but this was found to be insufficient for the needs and it was moved to the erecting shop, where it is used for casting hub liners, a larger one being installed in its place. There are also installed a magnetic separator, a 24 in. x 30 in. wet tumbler, a metal band saw and the necessary benches and grinder. In the general equipment of the plant there is a complete system of industrial tracks and turntables, as well as charging cars for pig iron and coke.

The foundry is under the direct supervision of J. H. Manning, superintendent of motive power, and G. S. Edmonds, superintendent of shops, Delaware & Hudson Company. V. Z. Caracristi was consulting engineer for the railway company in charge of the construction.

## General News.

The shops of the New York, Chicago & St. Louis, at Stony Island avenue and Ninety-first street, Chicago, were destroyed by fire on Wednesday last; loss, \$500,000. Seven hundred men are temporarily thrown out of employment.

On the Hannibal division of the Chicago, Burlington & Quincy between St. Louis and Burlington, Ia., train orders are now sent by telephone, following the completion of the telephone circuit between Hannibal and Burlington, about 100 miles.

The Department of Agriculture says that the government's forest rangers are using gasoline railway speeders for fire protection purposes. They follow up trains on steep grades where sparks thrown out by the locomotives are likely to start fires along the right of way.

The Chicago, Milwaukee & St. Paul, the Chicago, St. Paul, Minneapolis & Omaha, the Chicago & North Western, and the Illinois Central have notified the Wisconsin Industrial Commission of their determination not to come under the state workmen's compensation law.

The state attorney at Bridgeport, Conn., announces that he is going to ask for a special session of the Superior Court in the month of October, to try Messrs. Mellen and McHenry, former officers of the New Haven road, on charges of manslaughter in connection with the wreck at Westport last year.

The Canadian Pacific has fitted up a car for giving instruction in first aid to the injured. The car, with an instructor, has been started out on a complete tour of the system, from New Brunswick to the West. It will remain at each grand divisional point for about three weeks, and at the smaller ones for about ten days.

Incorporation papers have been taken out in Illinois for the Federation of Pullman Conductors of America and the Federation of Pullman Porters of America. Headquarters of both organizations will be in Chicago, and it is understood that after sufficient membership has been obtained efforts will be made to obtain increases in wages.

Arbitration of the demands of engineers and firemen on the Chicago & Western Indiana and the Belt Railway of Chicago for increases in pay and other schedule changes was begun at Chicago last week before Judge E. S. Huston, of Washington, D. C., F. A. Burgess, representing the employees, and W. J. Jackson, president of the Chicago & Eastern Illinois, representing the railways.

Of the 37 employees of the Pennsylvania Railroad Lines east and west of Pittsburgh who were put on the pension rolls on August 1, five had served 50 years or more; and a leaflet has been issued by the road containing sketches and portraits of these five men. They are J. M. Daugherty, boilermaker, J. G. Trout, engine preparer, E. Toy, conductor, John Quinn, car builder, and H. J. Amerling, tinner.

Senator O'Gorman of New York, has introduced in Congress a bill designed to prohibit the use of wooden cars in passenger trains after a certain date in the future. The senator would make it unlawful to introduce any new wooden cars after the end of this year; and at the same time he would extend to the whole train the present rule concerning mail cars, which forbids running wooden cars between those of steel.

The Kansas City Southern has appointed a valuation committee, to facilitate the preparation of the necessary data and the consideration of the problems involved in the valuation to be made by the Interstate Commerce Commission. The Committee consists of R. J. McCarty, vice-president, chairman; C. E. Johnston, chief engineer; S. W. Moore, general solicitor; G. F. Hess, superintendent of machinery, and A. F. Rust, valuation engineer.

Coroner Hoffman, of Cook county, Illinois, has invited 24 prominent citizens of Chicago to become members of a Safety First committee to seek remedies for the causes of automobile accidents, and to inaugurate a safety campaign. Several of those invited are in charge of safety work for corporations, and the



list includes two railway men, W. A. Garrett, vice-president of the Chicago Great Western, and R. H. Aishton, vice-president of the Chicago & North Western.

The House of Representatives, in its discussion this week of the urgent deficiency bill, again showed its determination to abolish the commerce court; and on Tuesday it went farther, and by a vote of 181 to 78, adopted an amendment, proposed by Mr. Bartlett, of Georgia, repealing the law under which the five judges were appointed, the intent of this amendment being to throw the present judges of the court out of office entirely, instead of leaving them in their present status as judges of the circuit courts.

#### Imprisonment for Sleeping on Duty.

At Lynbrook, N. Y., this week, Frank J. Berbitz, a railroad crossing flagman, was sentenced by Justice Neu to sixty days in the Nassau county jail for having fallen asleep at his post. He was flagman at the crossing of the Long Island road when two men in an automobile were killed recently. Two weeks ago, between 8 and 9 o'clock at night, a train came along and it was discovered that no one was on duty at the crossing. The train was stopped and Berbitz was found asleep in the flagman's shanty.

#### Half a Million Meals.

Some idea of the magnitude of the operations of the sleeping and dining car department of the Canadian Pacific is furnished by the fact that 4,000 men are employed, and within five or six days could transport an army of 30,000 people from Vancouver to Halifax, giving each person a berth in which to sleep and supply 90,000 meals a day, or practically half a million on the journey of 5½ days across the continent. The company's sleeping and dining cars would make a train 14 miles long.—*Canadian Pacific Bulletin*.

#### Record of a Pennsylvania Atlantic Type Locomotive.

On the night of August 15, 1913, Pennsylvania Railroad, class E-6a (Atlantic type) locomotive 1067 received train No. 19 at Manhattan Transfer, ½ min. late. This train is due to leave New York at 8:34 p. m., Manhattan Transfer at 8:52, North Philadelphia at 10:36; and to arrive at Broad street, Philadelphia, at 10:40 p. m. It left Newark three minutes late, on account of a very long stop, passed Perth Amboy 4½ min. late, due to the speed limit through Rahway, making the run from Perth Amboy Junction to Metuchen, 5.8 miles, in 7½ min., which is exceptionally good, considering the slow movement through Rahway. Between New Brunswick and Frankford Junction, 7 min. were made up, so that the train passed the latter point only ½ min. late, but 7 min. were lost from Frankford Junction to North Philadelphia, due to signals on account of train 155 being ahead. The train arrived at Broad street station 6 min. late, but would have gone in on time had it not been for the train ahead between Frankford Junction and North Philadelphia. The train consisted of ten steel Pullman sleeping cars, one combination passenger and baggage car, one coach and one postal car, the total weight being about 984 tons. No trouble was experienced in starting the train at Manhattan Transfer, Newark and North Philadelphia. The locomotive weighs approximately 235,000 lbs. The distance from Manhattan Transfer to Broad street station is 82.9 miles.

#### The Congressional Method.

Following considerable discussion of the recent collision at North Haven, Conn., and the advisability of passing laws to require the use of steel cars in passenger trains everywhere, the lower House of Congress, on Saturday last, adopted an amendment to the urgent deficiency bill, directing the Interstate Commerce Commission to investigate block signal systems and other safety devices, and granting for that purpose a special appropriation of \$25,000. Commenting on this, the *Evening Post*, New York, says:

The House of Representatives on Saturday gave an admirable illustration of foolish legislation by voting to appropriate \$25,000 for an investigation. . . . To the public at large this doubtless smacks of praiseworthy public spirit, following the latest New Haven wreck. The truth is, however, that such an appro-

priation would be an indefensible waste of public funds, for the reason that precisely this information has already been acquired at an expense of \$100,000. The Interstate Commerce Commission made a comprehensive report, which was printed February 23, 1907, as Senate Document No. 342. Later a "Block Signal and Train Control Board" was formed, which temporary body, composed of five experts, made no less than five exhaustive reports, covering all the questions involved and bringing them up to date. Any fresh investigation would merely cover the same ground.

The Interstate Commerce Commission, as a result, recommended—as it previously had—a law making block signaling compulsory. But Congress did nothing at all. Its members were "too busy" to read the reports, and probably many new members do not know that they exist. What Congress ought to do is to reconsider its action of Saturday, and, after study of what has already been presented to them, decide whether or not any Congressional action should be taken. Any other course will be an inexcusable waste of time and money.

#### A "Safety First" Swimming Pool on the Frisco.

The accompanying photograph illustrates a unique method of promoting "safety first" which has been adopted by C. H. Baltzell, superintendent of the Ozark division of the St. Louis & San Francisco at Thayer, Mo., as mentioned in the *Railway Age Gazette* of August 1, page 201. This is one of the methods which resulted in the Ozark division winning the "safety first" honors on that road last year by reducing the number of personal injury accidents 63 per cent.

Mr. Baltzell was formerly a physical culture teacher, and is a powerful athlete. When he took charge of the Ozark division he found that many boys in that community were in the habit of "hopping" trains. Police regulations and force had no effect upon the situation, but finally Mr. Baltzell hit upon the idea of the swimming pool. A platform, steps and swing board with



Frisco "Safety First" Swimming Pool.

a dressing room were installed at the old swimming hole in Warm Fork opposite the superintendent's office, after which Mr. Baltzell called the boys together and told them that the pool was at their disposal, and that he would teach them how to swim and other athletic "stunts" if they would stop "hopping" trains, and that any boy who was caught "hopping" the trains would be barred from the pool. Mr. Baltzell takes occasion frequently to talk briefly to the boys upon the dangers of playing about the trains, and as a result there are practically no accidents in Thayer, and the boys not only do not hop trains, but keep out of the yards. During eleven months of the last fiscal year there was not a boy injured on the Ozark division.

#### Last Stages of Panama Canal Work.

Press despatches of September 7 report that the dry excavation of the Panama canal has been completed, the steam shovel working in the Culebra cut having removed the last rock on the 6th. Further excavation of the canal will be completed by dredging. The present result has been accomplished ten days ahead of schedule time. An army of men will be

busy during the next four weeks removing steam shovels and other equipment and material, including 36 miles of railroad track, from the nine-mile channel in Culebra cut, between Gamboa dike and Pedro Miguel locks. This is preparatory to turning water into the channel from Gatun Lake, on the Atlantic side, on October 5, five days in advance of the date set for the dynamiting of Gamboa dike. The water will be introduced through four 26-in. pipes extending underneath the dike; and although the five-day period hardly will suffice to fill the channel to one-third the canal level, enough will be let into act as a cushion against the explosion when the dike is destroyed.

While the cut is being cleared of railway and equipment, drilling and blasting will be going on at the bottom of the channel, loosening rock and earth for the dredges that soon will be set to work. On August 1, 998,000 cu. yds. remained to be taken out of the "theoretical canal prism," and since that time the steam shovels have reduced the amount to approximately 650,000 cu. yds., which is left for the dredges. Six of the shovels, will be retained for the work of removing material from the east and west banks near Culebra to lessen the danger from slides.

The destruction of Gamboa dike will leave only one such obstruction along the canal route—the dike over which the railroad crosses at Gatun locks, and which can be removed at any time. The last barrier on the Pacific side, the Miraflores dike, has been broken up, turning Pacific tide water into a channel 5,000 ft. long, 500 ft. wide and 41 ft. deep.

Dredges are now navigating this channel, and small vessels probably will be able to pass through the canal from end to end by October 10.

#### Some of the Stuff the Dailies Printed About the Wreck.

The White Mountain express, with a superheated locomotive and eight steel cars.—*New York American*, September 3.

Miller worked night and day for an entire week.—*New York American*, September 4.

Connecticut state officials helped New Haven railroad in plot of secrecy.—*New York American*, September 4.

The old semaphore signals are still in use on this stretch of road.—Editorial from *New York Times*, September 3.

Dividends of death! Its out-of-date wooden car equipment, its treacherous signal system that allows two trains to be on the same track within a few yards of each other. . . .—*New York World*, September 3.

Engineman wept; knew road would put blame on him.—*New York World*, September 3.

"Overwork did it," says engineman's foster mother.—*New York World*, September 3.

Murder as an adjunct to monopoly.—*New York Evening Journal*, September 3.

The locomotive which did the frightful damage was of the 1300 type, similar to that which caused the loss of life in Stamford. Its number is 1337 and it is a superheated Mogul model.—*New York Evening Journal*, September 2.

The third pasteboard sleeper, the Chisholm, was hauled from the ditch by two giant cranes and started back to the New Haven repair yard. The reason assigned by one of the men for not burning the badly battered car was unique. "You see, it isn't badly damaged," he said. "It can be patched up and put in service again."—*New York Globe*, September 3.

That the tired out engineer, running through the fog at from 40 to 60 miles an hour, shot by signals, as declared by the railroad officials, is emphatically denied by Mrs. Scott.—*New York Globe*, September 3.

"Slept only two hours a day for a week," says his boarding house keeper.—*New York Globe*, September 3.

The railroad system of signals is shown to be in a state of chaos. . . . If trains must be held up at stations, hold them up until all is clear to the next station, no matter what the delay may be.—Editorial, *New York Mail*, September 3.

An inspection of the semaphore signal north of the wreck showed that it was still at danger. Engineer Miller says in an interview: "It was so thick I did not see any banjo signal set against me, and I did all I could to stop the train. I set all the brakes and then jumped."—*New York Mail*, September 2.

#### Mr. Elliott's Outline of the New Haven Plans.

After the hearing before Interstate Commerce Commissioner McChord which is reported at length elsewhere in this issue, President Elliott spoke to newspaper men about his plans for the immediate future of the New Haven. He said that one of the first steps will be to divide the present Shore Line Division into two divisions; thus giving two division organizations to do the work of supervision now being carried on by one superintendent and his staff.

The work on the installation of new semaphore signals, between New Haven and Springfield, with home and distant indications, which was begun several weeks ago, will be hastened.

Present plans, President Elliott says, provide for a substitution of steel for all of the wooden sleeping and parlor cars by January 1, 1914. Of course, this plan is dependent on the ability of the Pullman Company to furnish steel cars within this time; and in addition to the pressure being brought to bear on the Pullman Company, rush orders have been sent to other car builders calling for the building of steel coaches, etc., for the New Haven itself. The total expenditure on this account will be in the neighborhood of \$6,500,000.

On Tuesday, President Elliott and Mr. Rea, of the Pennsylvania, who is a director of the New Haven, appeared before the Massachusetts Railroad Commission, asking approval of the proposed issue of \$67,500,000 debentures. During the course of this hearing Mr. Elliott said: "There are \$46,000,000 of debts to be paid. The company has contracted for approximately \$7,000,000 of the most modern type of equipment that will make for safety of the traveling public. We have further contracted over four years for equipment of like character of nearly \$7,000,000 more. The bulk of this expenditure is for steel cars to put on passenger trains. In addition there are betterments of general character amounting to something like \$12,000,000. These sums, with the lawful debts to be paid, amount to between \$65,000,000 and \$66,000,000. To keep this great tool of commerce in a safe condition will take more money. Every day something comes up. . . . These daily expenditures for capital account run into considerable amounts; \$10,000,000 or \$15,000,000 a year is not too low for this company.

#### Newspapers' Comments on the New Haven.

"Congress stirred by wreck," runs a headline. If Congress stirred a little between wrecks it would be better for legislation. The public may forget quickly, but one expects more of statesmen.—*Springfield Republican*.

It was the rear coaches of the forward train that suffered in both cases, and in the English accident the wreckage caught fire. That similar accidents occurred on two widely separated roads on the same morning cannot be put out by either as an excuse or apology; but it shows that the "New Haven" is not the only road that is not exempt from such sad calamities.—*Hartford Courant*.

The unanimity with which the newspapers condemn the system of operation on the New Haven lines for the awful wreck of Tuesday follows a hesitant, but enforced, change of heart on the part of many editors who have in the past steadfastly refused to succumb to public hysteria or to let their sense of horror overcome their sober judgment. But the change had to come. The conclusion is almost unescapable that something in the fundamentals of management must be wrong.—*Hartford Times*.

We take it that the bankers of New York and those of Boston have reached a working agreement as to the division of the financial spoils. It looks so on the surface of things. Boston's pride has been mollified by the decision of Mr. Elliott to eventually make his home there. Well, Connecticut will not worry about that, but it will begin to pick up its ears mighty fast if the proposal is seriously made to eliminate from the official title of the company the words New Haven. This town is the legal headquarters of the company. . . . There is no reason worthy of recognition why "New Haven" should be jauntily eliminated to suit the wounded vanity of Boston. So with the persistent rumor that the next Legislature will be asked to repeal the provision requiring a majority of the directors to be residents of Connecticut.—*New Haven Journal-Courier*.

The New Haven wreck carries one compelling lesson to every railroad in the United States. There must be a speedy replacement of wooden cars with all-steel cars. In a recent Pennsylv-

vania wreck exactly similar to that on the New Haven more than 150 persons were only slightly injured, and not a single passenger suffered a broken bone; but the cars were solid steel.—*Philadelphia Public Ledger*.

Whether on the unfortunate New England lines or on any other railroad, a rear-end collision is inexplicable and indefensible on any theory of train operation that includes reasonable discipline and intelligent regulations. No assumed public demand for speed and no clerical record of train arrivals can excuse or condone a rear-end collision. On the subject of wooden coaches, let it be remembered that the vast majority of passengers ride safely and comfortably in such vehicles daily, without thought of danger. The composition of cars is of importance, but it is emphatically of less interest than the management of trains.—*New York Sun*.

Can anybody in New Haven or Connecticut regard the so-called investigation of the causes of the North Haven wreck by the Interstate Commerce Commission as anything more than a farce? After flamboyant demands from Washington and promises of a vigorous, thorough and impartial investigation, a hearing lasting less than two days was held, and that hearing devoted largely to club cars between Stamford and New York and the signal equipment on distant parts of the New Haven system. There was no attempt to investigate any of the 158 cases of running by signals nor the reasons therefor. No attempt to subpoena those who might tell of similar cases of lack of discipline or unavoidable mistakes where terrible loss of life might have occurred, but did not. Why not? Why was there not a comprehensive effort made to get at the conditions that have resulted in all this criminal carelessness? Did the Interstate Commerce delegation that came here want to get at real causes? Or did they want to indulge in a little vague criticism of the New Haven management and play to the gallery? They came on and lived comfortably, even luxuriously, at the Taft Hotel, with a force of clerks and stenographers, and occupied eight or nine rooms. It must have been a very pleasant junket, costing the federal government and the taxpayers a good round sum of money.—*New Haven Register*.

#### American Association of Passenger Agents.

The annual convention of the American Association of Passenger Agents was held at St. Paul, Minn., on September 8-9. Approximately 200 members of the association left the Chicago terminal of the Chicago & North Western on Saturday, September 6, after an inspection of the terminal, and another party of members joined them at Madison, Wis. The two principal subjects for discussion at the convention were "The Field Man," and "How to Increase Our Efficiency to the Public and Our Employers." At the close of the convention the members were taken on a trip through Yellowstone National Park as guests of the Northern Pacific by a special train to Gardiner, Mont., and thence by stage.

Officers of this association were elected as follows: President, R. T. G. Matthews, assistant general passenger agent, Missouri Pacific, Kansas City, Mo.; vice-president, M. F. Bragg, Norfolk, Va.; secretary-treasurer, E. T. Monett, general western passenger agent, New York, Ontario & Western, re-elected.

It was decided to change the name of the association to the American Association of Traveling Passenger Agents.

#### American Society of Mechanical Engineers.

The date of the railway session of the fall meeting of the American Society of Mechanical Engineers has tentatively been arranged for the afternoon of December 3. The topic for discussion will be Steel and Steel Underframe Box Cars. As the result of replies to a circular letter it has been decided to restrict the scope of the papers to secure more detailed discussion. W. F. Keisel, Jr., assistant engineer, Pennsylvania Railroad, has been asked to prepare a paper on All Steel Box Cars; and R. W. Burnett, M. C. B., Canadian Pacific, on Steel Underframe Box Cars. E. O. Chenoweth (Rock Island Lines), R. B. Kendig (New York Central Lines), and B. D. Lockwood, chief engineer, Pressed Steel Car Company, Pittsburgh, Pa., have been asked to prepare written discussions on the former paper; and G. W. Rink (C. of N. J.), O. C. Cromwell (B. & O.), and A. Christiansen, chief engineer, Standard Steel Car Company, Pittsburgh, Pa., have been asked to prepare written discussions on the latter.

#### Master Painters' Association.

The forty-fourth annual convention of the Master Car & Locomotive Painters' Association was held at the Chateau Laurier, Ottawa, Canada, September 9 to 12, President A. J. Bush, master painter, Delaware & Hudson, Oneonta, N. Y., presiding. Rev. W. A. McIlroy, of the Stewarton Presbyterian Church, offered the opening prayer. The association was welcomed to the city by Mayor J. A. Ellis, who is also a member of the provincial parliament of Ontario, and Dr. R. H. Parent, one of the four comptrollers. The addresses of welcome were responded to by C. A. Copp, master painter of the Boston & Maine. A report of the proceedings will be included in the issue of next week.

#### Roadmasters' Convention.

The thirty-first annual convention of the Roadmasters' and Maintenance of Way Association was held in the Auditorium hotel, Chicago, September 9-12. The opening session Tuesday morning was called to order at 11 o'clock, by President William Shea. Over 200 roadmasters were in attendance, and about 50 manufacturers of track materials and devices had exhibits in the corridors of the hotel, making the convention fully up to the standard of previous years, both in point of attendance and importance of exhibit. A complete report of the convention will be published in the "Maintenance of Way Section" next week.

#### Efficiency Society.

The first fall meeting of the Efficiency Society will be held at the Lake Placid Club, Essex county, N. Y., in the Adirondack mountains, September 19-21. The meeting will consist of a series of conferences on efficiency in non-profit making institutions, such as the church, hospital, charity, philanthropic and civic organizations, the government, federal, state, county municipal, etc.

#### Signal Appliance Association.

The annual meeting of the Signal Appliance Association will be held at the Hermitage Hotel, Nashville, Tenn., October 14-17, in connection with the annual convention of the Railway Signal Association. An attractive program of entertainment has been arranged by the secretary of the Appliance association.

#### MEETINGS AND CONVENTIONS.

*The following list gives names of secretaries, dates of next or regular meetings, and places of meeting.*

- AIR BRAKE ASSOCIATION.—F. M. Nellis, 53 State St., Boston, Mass. Next convention, May, 1914.
- AMERICAN ASSOCIATION OF DEMURRAGE OFFICERS.—A. G. Thomson, Boston, Mass. Convention, May 19, 1914, St. Louis.
- AMERICAN ASSOCIATION OF GENERAL PASSENGER AND TICKET AGENTS.—W. C. Hope, New York. Annual meeting, October 14-15, Philadelphia, Pa.
- AMERICAN ASSOCIATION OF FREIGHT AGENTS.—R. O. Wells, East St. Louis, Ill.
- AMERICAN ASSOCIATION OF RAILROAD SUPERINTENDENTS.—E. H. Harman, St. Louis, Mo.; 3d Thursday and Friday in May.
- AMERICAN ELECTRIC RAILWAY ASSOCIATION.—H. C. Donecker, 29 W. 39th St., New York. Next convention, October 13-17, Atlantic City, N. J.
- AMERICAN ELECTRIC RAILWAY MANUFACTURERS' ASSOC.—H. G. McConaughy, 165 Broadway, New York. Meetings with Am. Elec. Ry. Assoc.
- AMERICAN RAILWAY ASSOCIATION.—W. F. Allen, 75 Church St., New York. Next meeting, November 19, 1913, Chicago.
- AMERICAN RAILWAY BRIDGE AND BUILDING ASSOCIATION.—C. A. Lichty, C. & N. W., Chicago. Convention, October 21-24, 1913, Montreal.
- AMERICAN RAILWAY ENGINEERING ASSOCIATION.—E. H. Fritch, 900 S. Michigan Ave., Chicago.
- AMERICAN RAILWAY MASTER MECHANICS' ASSOCIATION.—J. W. Taylor, Old Colony building, Chicago.
- AMERICAN RAILWAY TOOL FOREMEN'S ASSOCIATION.—A. R. Davis, Central of Georgia, Macon, Ga.
- AMERICAN SOCIETY FOR TESTING MATERIALS.—Prof. E. Marburg, University of Pennsylvania, Philadelphia, Pa.
- AMERICAN SOCIETY OF CIVIL ENGINEERS.—C. W. Hunt, 220 W. 57th St., New York; 1st and 3d Wed., except June and August, New York.
- AMERICAN SOCIETY OF ENGINEERING CONTRACTORS.—J. R. Wenlinger, 11 Broadway, New York; 2d Tuesday of each month, New York.
- AMERICAN SOCIETY OF MECHANICAL ENGINEERS.—Calvin W. Rice, 29 W. 39th St., New York.
- AMERICAN WOOD PRESERVERS' ASSOCIATION.—F. J. Angier, B. & O., Baltimore, Md. Next convention, January 20-22, 1914, New Orleans, La.
- ASSOCIATION OF AMERICAN RAILWAY ACCOUNTING OFFICERS.—C. G. Phillips, 143 Dearborn St., Chicago. Annual meeting, May 28, Atlantic City, N. J.
- ASSOCIATION OF RAILWAY CLAIM AGENTS.—C. W. Egan, B. & O., Baltimore, Md. Next convention, May, 1914, St. Paul, Minn.
- ASSOCIATION OF RAILWAY ELECTRICAL ENGINEERS.—Jos. A. Andreucetti, C. & N. W. Ry., Chicago. Annual convention, October 18-24, Chicago.
- ASSOCIATION OF RAILWAY TELEGRAPH SUPERINTENDENTS.—P. W. Drew, 112 West Adams St., Chicago. Next convention, May 20-23, New Orleans, La.
- ASSOCIATION OF TRANSPORTATION AND CAR ACCOUNTING OFFICERS.—G. P. Conard, 75 Church St., New York. Next meeting, December 9-10, Galveston, Tex.

**ASSOCIATION OF WATER LINE ACCOUNTING OFFICERS.**—W. R. Evans, Chamber of Commerce, Buffalo, N. Y. Annual meeting, October 8, Philadelphia, Pa.

**BRIDGE AND BUILDING SUPPLY MEN'S ASSOCIATION.**—H. A. Neally, Joseph Dixon Crucible Co., Jersey City, N. J. Meeting with American Railway Bridge and Building Association.

**CANADIAN RAILWAY CLUB.**—James Powell, Grand Trunk Ry., Montreal, Que.; 2d Tuesday in month, except June, July and Aug., Montreal.

**CANADIAN SOCIETY OF CIVIL ENGINEERS.**—Clement H. McLeod, 413 Dorchester St., Montreal, Que.; Thursday, Montreal.

**CAR FOREMEN'S ASSOCIATION OF CHICAGO.**—Aaron Kline, 841 North 50th Court, Chicago; 2d Monday in month, Chicago.

**CENTRAL RAILWAY CLUB.**—H. D. Vought, 95 Liberty St., New York; 2d Thurs. in Jan. and 2d Fri. in March, May, Sept., Nov., Buffalo, N. Y.

**CIVIL ENGINEERS' SOCIETY OF ST. PAUL.**—L. S. Pomeroy, Old State Capitol building, St. Paul, Minn.; 2d Monday, except June, July, August and September, St. Paul.

**ENGINEERS' SOCIETY OF PENNSYLVANIA.**—E. R. Dasher, Box 704, Harrisburg, Pa.; 1st Monday after 2d Saturday, Harrisburg, Pa.

**ENGINEERS' SOCIETY OF WESTERN PENNSYLVANIA.**—E. K. Hiles, Oliver building, Pittsburgh; 1st and 3d Tuesday, Pittsburgh, Pa.

**FREIGHT CLAIM ASSOCIATION.**—Warren P. Taylor, Richmond, Va. Next convention, May 20-22, Galveston, Tex.

**GENERAL SUPERINTENDENTS' ASSOCIATION OF CHICAGO.**—E. S. Koller, 226 W. Adams St., Chicago; Wed. preceding 3d Thurs., Chicago.

**INTERNATIONAL RAILWAY CONGRESS.**—Executive Committee, 11, rue de Louvain, Brussels, Belgium. Convention, 1915, Berlin.

**INTERNATIONAL RAILWAY FUEL ASSOCIATION.**—C. G. Hall, 922 McCormick building, Chicago. Annual convention, May 18-22, Chicago.

**INTERNATIONAL RAILWAY GENERAL FOREMEN'S ASSOCIATION.**—Wm. Hall, 829 West Broadway, Winona, Minn.

**INTERNATIONAL RAILROAD MASTER BLACKSMITHS' ASSOCIATION.**—A. L. Woodworth, Lima, Ohio.

**MAINTENANCE OF WAY & MASTER PAINTERS' ASSOCIATION OF THE UNITED STATES AND CANADA.**—W. G. Wilson, Lehigh Valley, Easton, Pa.

**MASTER BOILER MAKERS' ASSOCIATION.**—Harry D. Vought, 95 Liberty St., New York.

**MASTER CAR BUILDERS' ASSOCIATION.**—J. W. Taylor, Old Colony building, Chicago.

**MASTER CAR AND LOCOMOTIVE PAINTERS' ASSOC. OF U. S. AND CANADA.**—A. P. Danc, B. & M., Reading, Mass.

**NATIONAL RAILWAY APPLIANCE ASSOC.**—Bruce V. Crandall, 537 So. Dearborn St., Chicago. Meetings with Am. Ry. Eng. Assoc.

**NEW ENGLAND RAILROAD CLUB.**—W. E. Cade, Jr., 683 Atlantic Ave., Boston, Mass.; 2d Tuesday in month, except June, July, Aug. and Sept., Boston.

**NEW YORK RAILROAD CLUB.**—H. D. Vought, 95 Liberty St., New York; 3rd Friday in month, except June, July and August, New York.

**NORTHERN RAILROAD CLUB.**—C. L. Kennedy, C. M. & St. P., Duluth, Minn.; 4th Saturday, Duluth.

**PEORIA ASSOCIATION OF RAILROAD OFFICERS.**—M. W. Rotchford, Union Station, Peoria; 2d Thursday.

**RAILROAD CLUB OF KANSAS CITY.**—C. Manlove, 1008 Walnut St., Kansas City, Mo.; 3d Friday in month, Kansas City.

**RAILWAY BUSINESS ASSOCIATION.**—Frank W. Noxon, 2 Rector St., New York. Annual dinner, second week in December, 1913, New York.

**RAILWAY CLUB OF PITTSBURGH.**—J. B. Anderson, Penna. R. R., Pittsburgh, Pa.; 4th Friday in month, except June, July and August, Pittsburgh.

**RAILWAY ELECTRICAL SUPPLY MANUFACTURERS' ASSOC.**—J. Scribner, 1021 Monadnock Block, Chicago. Meetings with Assoc. Ry. Elec. Engrs.

**RAILWAY FIRE PROTECTION ASSOCIATION.**—C. B. Edwards, Mobile & Ohio, Mobile, Ala. Next meeting, October 7, Chicago.

**RAILWAY GARDENING ASSOCIATION.**—J. S. Butterfield, Lee's Summit, Mo.

**RAILWAY DEVELOPMENT ASSOCIATION.**—W. Nicholson, Kansas City Southern, Kansas City, Mo.

**RAILWAY SIGNAL ASSOCIATION.**—C. C. Rosenberg, Bethlehem, Pa. Convention, October 14, Nashville, Tenn.

**RAILWAY STOREKEEPERS' ASSOCIATION.**—J. P. Murphy, Box C, Collinwood, Ohio.

**RAILWAY SUPPLY MANUFACTURERS' ASSOC.**—J. D. Conway, 2135 Oliver bldg., Pittsburgh, Pa. Meetings with M. M. and M. C. B. Assocs.

**RAILWAY TEL. & TEL. APPLIANCE ASSOC.**—W. E. Harkness, 284 Pearl St., New York. Meetings with Assoc. of Ry. Teleg. Sups.

**RICHMOND RAILROAD CLUB.**—E. O. Robinson, Richmond, Va.; 2d Monday except June, July and August.

**ROADMASTERS AND MAINTENANCE OF WAY ASSOCIATION.**—L. C. Ryan, C. & N. W., Sterling, Ill.

**ST. LOUIS RAILWAY CLUB.**—B. W. Frauenthal, Union Station, St. Louis, Mo.; 2d Friday in month, except June, July and Aug., St. Louis.

**SIGNAL APPLIANCE ASSOCIATION.**—F. W. Edmonds, 3868 Park Ave., New York. Meeting with annual convention Railway Signal Association.

**SOCIETY OF RAILWAY FINANCIAL OFFICERS.**—C. Nyquist, La Salle St. Station, Chicago. Annual meeting, September 23-25, Chicago.

**SOUTHERN ASSOCIATION OF CAR SERVICE OFFICERS.**—E. W. Sandwich, A. & W. P. Ry., Montgomery, Ala.

**SOUTHERN & SOUTHWESTERN RAILWAY CLUB.**—A. J. Merrill, Grant bldg., Atlanta, Ga.; 3d Thurs., Jan., March, May, July, Sept., Nov., Atlanta.

**TOLEDO TRANSPORTATION CLUB.**—J. G. Macomber, Woolson Spice Co., Toledo, Ohio; 1st Saturday, Toledo.

**TRACK SUPPLY ASSOCIATION.**—W. C. Kidd, Ramapo Iron Works, Hillsburn, N. Y. Meeting with Roadmasters' and Maintenance of Way Association.

**TRAFFIC CLUB OF CHICAGO.**—W. H. Wharton, La Salle Hotel, Chicago.

**TRAFFIC CLUB OF NEW YORK.**—C. A. Swope, 290 Broadway, New York; last Tuesday in month, except June, July and August, New York.

**TRAFFIC CLUB OF PITTSBURGH.**—D. L. Wells, Erie, Pittsburgh, Pa.; meetings monthly, Pittsburgh.

**TRAFFIC CLUB OF ST. LOUIS.**—A. F. Versen, Mercantile Library building, St. Louis, Mo. Annual meeting in November. Noonday meetings October to May.

**TRAIN DESPATCHERS' ASSOCIATION OF AMERICA.**—J. F. Mackie, 7122 Stewart Ave., Chicago.

**TRANSPORTATION CLUB OF BUFFALO.**—J. M. Sells, Buffalo; first Saturday after first Wednesday.

**TRANSPORTATION CLUB OF DETROIT.**—W. R. Hurley, L. S. & M. S., Detroit, Mich.; meetings monthly.

**TRAVELING ENGINEERS' ASSOCIATION.**—W. O. Thompson, N. Y. C. & H. R., East Buffalo, N. Y.

**UTAH SOCIETY OF ENGINEERS.**—Fred D. Ulmer, Oregon Short Line, Salt Lake City, Utah; 3d Friday of each month, except July and August.

**WESTERN CANADA RAILWAY CLUB.**—W. H. Rosevear, P. O. Box 1707, Winnipeg, Man.; 2d Monday, except June, July and August, Winnipeg.

**WESTERN RAILWAY CLUB.**—J. W. Taylor, Old Colony building, Chicago; 3d Tuesday of each month, except June, July and August.

**WESTERN SOCIETY OF ENGINEERS.**—J. H. Warder, 1735 Monadnock Block, Chicago; 1st Monday in month, except July and August, Chicago.

# Traffic News.

The Western Passenger Association, at a meeting on September 4, declined to grant rates lower than two cents a mile for a number of conventions to be held in St. Louis in October.

Commissioner John H. Marble, of the Interstate Commerce Commission, was the guest of the Transportation Club of San Francisco, at a luncheon on September 5, and gave an informal address.

The Pennsylvania Railroad has made an arrangement with Thomas Cook & Sons, the tourist agents, whereby the lines of the Pennsylvania System will be represented by Messrs. Cook at their offices in all parts of the world.

It is announced that the Trunk Line and Central Traffic Association roads will probably file their new tariffs, increasing rates about five per cent., on or about October 15. Reports of railroad revenues during the past few months, disproving predictions that there would be large increases, are expected to afford good support of the claims of the roads that increased rates are necessary.

The Chicago, Burlington & Quincy, in co-operation with the Iowa State Agricultural college, will shortly operate a special apple demonstration train through the rural districts of Iowa. Lectures will be given on apple picking, packing, storage and marketing, and demonstrations will be given with various special apparatus for this purpose. It is estimated that the state of Iowa will produce about 5½ million bushels of apples this year.

The special committee appointed by the Public Service Commission of West Virginia to see to the redeeming of the coupons which have been issued by the Chesapeake & Ohio to passengers who paid at the higher rates while the courts were considering the suit of the company to annul the law reducing rates, is said to have received already 60 bushels of coupons. The value of these coupons ranges from one cent to \$3. An officer of the road estimates that the aggregate amount to be refunded is several hundred thousand dollars.

The freight and transportation department of the New Orleans Board of Trade has issued a circular to its members stating that the volume of traffic which will be offered to carriers during the coming fall and winter will tax to the utmost their transportation facilities, and with a view to co-operating with the carriers, and assisting them in the prompt movement of cars, all shippers are urgently requested to load cars as near their carrying capacity as commercial conditions will permit, and particularly to make all possible effort to promptly release cars.

## General Crop Conditions.

The Department of Agriculture estimates crop conditions to be as follows:

Crops.	FOR THE UNITED STATES.			Acreage, 1913.		
	1913.	1912.	Ten-yr. av.	Aug. 1, 1913.	P. Ct. of 1912.	Acres.
Corn	65.1	82.1	80.9	75.8	99.8	106,884,000
Winter wheat	.....	.....	.....	.....	116.4	30,938,000
Spring wheat	*75.3	*90.8	*76.9	74.1	97.0	18,663,000
Oats	*74.0	*92.3	*79.3	73.7	101.1	38,341,000
Barley	*73.4	*88.9	*81.1	74.9	96.3	7,255,000
Rye	.....	.....	.....	.....	100.8	2,134,000
Buckwheat	75.4	91.6	87.0	85.5	100.0	841,000
White potatoes	69.9	87.2	79.4	78.0	99.3	3,685,000
Tobacco	74.5	81.1	81.5	78.3	93.4	1,144,500
Flax	74.9	86.3	80.9	77.4	85.1	2,425,000
Rice	88.0	88.8	89.2	88.7	114.0	824,100
Hay, all tame	.....	.....	.....	81.8	97.5	48,293,000
Apples	47.7	67.9	54.4	52.2	.....	.....

\*Condition at time of harvest.

Market experts now calculate that the total corn crop will be about 2,350,000,000 bushels.

## Passenger Fares in Alabama.

In regard to the recent court action in Alabama concerning passenger fares a correspondent writes as follows:

"In 1907 the legislature established a standard passenger fare in Alabama for roads operating 100 miles or more within the state, of 2½ cents per mile. All of the trunk lines within the state sued out injunctions against this passenger rate in conjunction with a certain schedule of freight rates on what was known as the 110 commodities, established also by the legislature. Sub-

sequent to the securing of the temporary injunction, these roads asking for said injunction agreed to put this passenger rate in effect with some modifications allowed in the freight schedule, with the exception of the Louisville & Nashville, the Central of Georgia, the Western of Alabama, the South & North Alabama, a subsidiary of the Louisville & Nashville, and the Nashville, Chattanooga & St. Louis. These roads have secured a permanent injunction in the U. S. District Court against this legislative enactment, both freight and passenger.

"About one year ago, the Railroad Commission of Alabama, of its own initiative, cited these contesting lines of railway to appear before it, and show cause why the commission, after investigation, should not establish a just and reasonable passenger rate, it being the opinion of the commission, without hearing the evidence, that a 3-cent rate, then used, was probably an unreasonable rate. After taking evidence, the commission issued an order to all of these roads requiring them to adopt a passenger rate that the commission established, 2½ cents a mile, except that the commission has not yet finished hearing the Nashville, Chattanooga & St. Louis case.

"The Louisville & Nashville asked for a restraining order against the commission's order, which said restraining order has been refused, and the 2½ cent passenger rate is now in effect on the L. & N. The other roads have also asked for a restraining order, and the court has not yet determined whether or not said restraining order will be granted. Presumably, this will be settled this week."

**Car Balance and Performance.**

Arthur Hale, chairman of the committee on relations between railroads of the American Railway Association, in presenting statistical bulletin No. 152, covering car balances and performances for May, says:

The miles per car per day for May were 25.0 compared with 24.0 in April. This figure for May, 1912, was 23.7.

Ton miles per car per day for May were 387, compared with 369 in April. This is an increase of 10.57 per cent. over the figure for May, 1912, which was 350.

The proportion of home cars on line increased two points

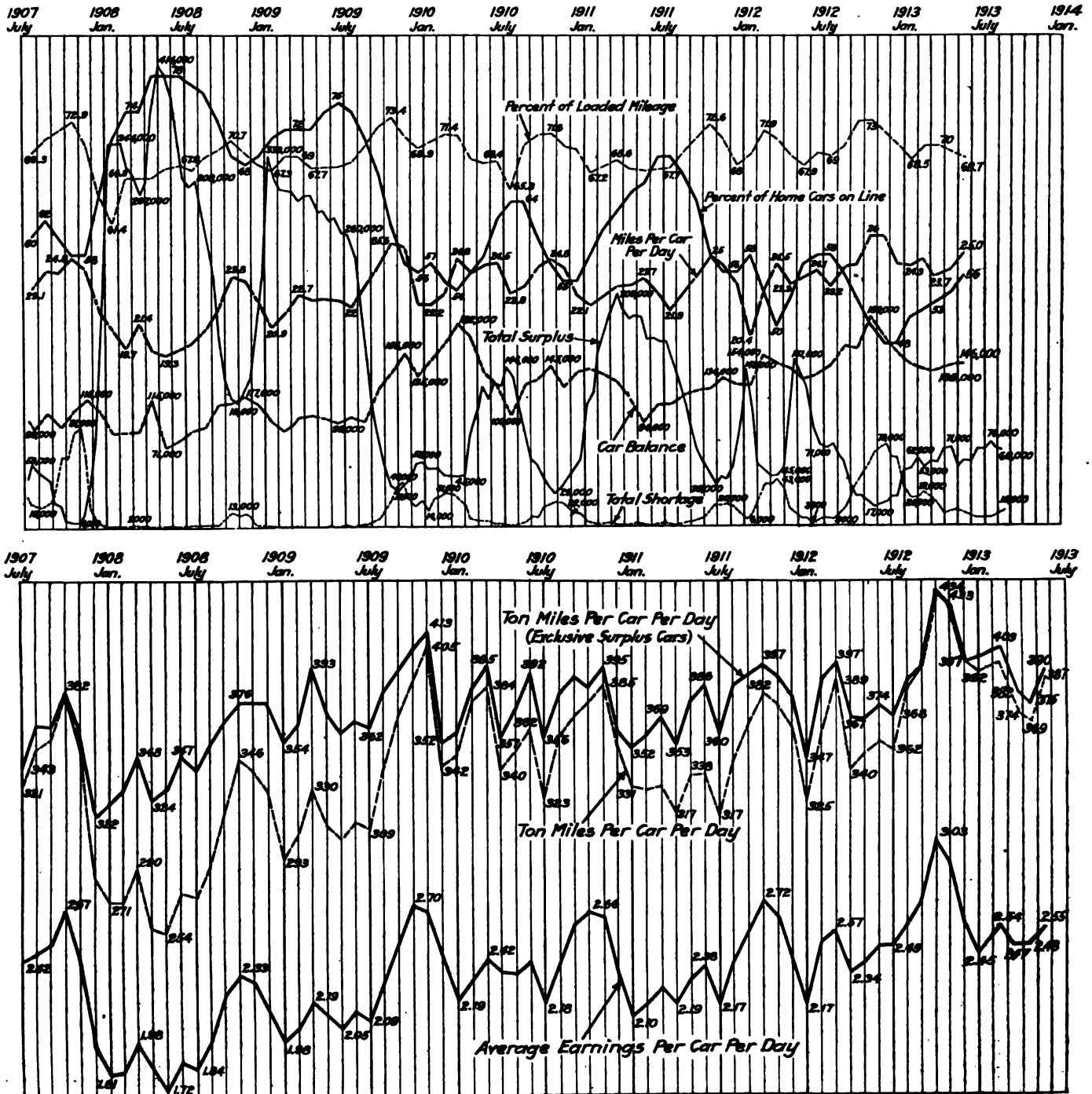

Freight Car Mileage, Earnings and Performance, 1907 to 1913.

CAR BALANCE AND PERFORMANCE IN MAY, 1913.

	New England.	N. Y., N. J., Del., Md., Eastern Pa.	Ohio, Ind., Mich., Western Pa.	Va., W. Va., No. and So. Carolina.	Ky., Tenn., Miss., Ala., Ga., Fla.	Iowa, Ill., Wis., Minn., Dakotas.	Mont., Wyo., Neb., Colo., Okla., Mo., Ark.	Kan., Texas, La., New Mex.	Ore., Idaho, Nev., Cal., Ariz.	Canadian Lines.	Grand Total.
Revenue freight cars owned.....	89,800	689,801	219,454	188,887	171,421	18,061	133,490	31,364	136,553	136,672	2,244,552
Average number of system cars on line.....	43,091	361,026	123,865	100,711	80,500	290,659	69,498	19,144	73,836	91,136	1,259,448
Railway-owned cars: Average foreign on line.....	52,982	325,258	124,955	78,793	78,439	144,059	56,588	21,886	42,887	44,651	978,950
Total Railway-owned cars on line.....	95,673	686,284	248,820	179,504	158,939	434,718	126,086	41,030	116,693	135,789	2,238,438
Excess.....	5,873	3,517	29,366	9,383	12,482	5,669	7,404	9,666	19,860	883	6,114
Per cent. of cars on line to total owned:											
Home.....	48	52	56	53	47	68	52	61	54	67	56
Foreign.....	59	47	57	42	46	33	38	70	31	32	44
All railroads.....	107	99	113	95	93	101	90	131	85	99	100
Private cars on line.....	3,732	36,112	11,557	5,215	10,673	14,977	7,841	4,311	9,829	2,659	108,828
Total, all cars on line.....	99,405	722,396	260,377	184,719	169,612	449,695	133,927	45,341	126,522	138,448	2,347,266
No. of freight engines owned.....	7,339	6,022	8,668	7,511	10,227	5,700	7,851	6,711	6,533	4,137	6,885
Average cars on line per freight engine owned.....	1,442	10,442	3,171	3,453	2,826	6,966	2,737	913	2,802	2,268	37,008
Total freight-car mileage.....	60,527,120	555,482,214	174,439,528	150,342,959	145,450,907	325,235,713	95,745,241	40,099,982	123,188,977	115,680,398	1,810,831,788
Average mileage per car per day.....	19.6	24.8	21.3	26.3	27.7	23.2	24.3	28.5	31.4	27.0	25.0
Per cent. loaded mileage.....	73.0	67.0	69.2	65.7	74.5	68.9	63.9	68.9	68.6	73.3	68.7
Ton-miles of freight, including company freight.....	709,417,109	9,293,567,862	3,109,193,071	2,383,587,079	2,039,283,003	3,604,693,201	405,039,383	1,354,035,605	1,721,341,704	1,666,956,043	26,761,610,385
Average ton-miles, including company freight:											
Per car-mile.....	11.7	16.7	18.4	15.9	14.0	14.5	14.1	11.8	14.2	14.4	15.5
Per loaded car-mile.....	16.1	25.0	26.6	24.1	22.6	20.7	20.5	18.5	20.8	19.6	22.6
Per car per day.....	230	415	393	416	389	336	344	338	446	368	387
Gross freight earnings.....	\$7,608,707	\$53,582,554	\$16,584,031	\$13,535,549	\$13,336,538	\$33,978,804	\$2,851,909	\$3,910,109	\$17,467,730	\$11,232,534	\$185,311,344
Average daily earnings: Per car owned.....	\$2.73	\$2.50	\$2.44	\$2.31	\$2.51	\$2.55	\$2.62	\$4.02	\$4.14	\$2.65	\$2.66
Per railroad car on line.....	2.57	2.52	2.15	2.43	2.71	2.92	2.92	3.07	4.85	2.67	2.67
All cars on line.....	2.47	2.40	2.05	2.36	2.54	2.44	2.75	2.78	4.48	2.62	2.55

\* Denotes deficiency.

to 56 per cent. in May, 1913, compared with 57 per cent. in May, 1912.

The per cent. of loaded car mileage for May, 1913, was 68.7 per cent., compared with 69.4 per cent. in April. This figure for May, 1912, was 67.9 per cent.

The average earnings per car per day for all cars on line for May were \$2.55, compared with \$2.48 in April. This is an increase of 6.69 per cent. over the earnings for May, 1912, which were \$2.39.

The accompanying table gives the car balance and performance in the month covered by the report, and the diagrams show car earnings and car mileage and different car performance figures monthly from July, 1907.

INTERSTATE COMMERCE COMMISSION.

Commissioner Prouty held a hearing at Chicago on September 8 on a complaint filed by the Springfield Commercial Association asking a reduction in rates from the East from a basis of 117 per cent. of the New York to Chicago rate to 110 per cent., which is the Peoria basis.

Commissioner Prouty began a hearing at Chicago on September 9 on a complaint filed by fifteen lumber mills in the vicinity of Little Rock, Ark., attacking the present system of rates on yellow pine lumber under which blanket rates are made to northern points from the group extending from Little Rock to the Gulf of Mexico west of the Mississippi. The complainants allege they are discriminated against to the extent of 2 to 4 cents per 100 lbs. as compared with rates from points east of the river, and ask that the group be divided on the Arkansas-Louisiana line. The rates to the gateways are now: Cairo, 16 cents, applying as a basing rate to C. F. A. points; St. Louis, 19 cents; Kansas City, 24 cents; Memphis, 14 cents. A reduction is asked of 6 cents to Kansas City and 4 cents to the other gateways from points north of the proposed group line. The complainants are represented by W. E. McCormack and M. M. Armistead.

Advisory Valuation Committee.

The Interstate Commerce Commission announces the establishment of an "advisory committee" of five members to occupy an intermediate position between the board of engineers in charge of railroad valuation and the commission itself. Four of the members of the committee are, Charles S. Staples, railroad commissioner of Minnesota; City Engineer Bemis of Chicago; Prof. Henry C. Adams of the University of Michigan and formerly statistician to the commission, and W. C. Williams, an engineer of Virginia.

STATE COMMISSIONS.

The Indiana Railroad Commission has appointed Commissioners Payne and McClure as a committee to investigate the block signal situation and report what further block signal installations should be ordered, and Commissioners McClure and Clark have been appointed a committee to draft a new order regulating locomotive headlights.

COURT NEWS.

Commerce Court.

Judge Carland, of the Commerce Court, dismissed the complaint of the Louisville & Nashville against the Interstate Commerce Commission, in which the railroad asked the Commerce Court to set aside the order of the commission denying relief from the Fourth section on traffic between Louisville, Ky., and Nashville, Tenn. Basing his opinion on the *Procter & Gamble* case, 225 U. S., 282, Judge Carland found that the Commerce Court had no jurisdiction to review the action of the commission in dismissing complaints or denying petitions. The ruling in the *Procter & Gamble* decision was substantially as follows: The Commerce Court has jurisdiction only to entertain complaints as to affirmative orders of the commission; that is, the court has the right to take cognizance of complaints concerning the legality of orders rendered by the commission, and power to relieve parties in whole or in part from the duty of obedience to orders which are found to be illegal.

REVENUES AND EXPENSES OF RAILWAYS.

MONTH OF JUNE, 1913.

Name of road.	Average mileage operated during period.		Operating revenues			Maintenance			Operating expenses			Net operating revenue (or deficit).	Outside operations, net.	Taxes.	Operating income (or loss).	Increase (or decr.) comp. with last year.
	Freight.	Passenger.	Total.	Way and structures.	Misc. equipment.	Trans- portation.	General.	Total.	Traffic.	Trans- portation.	General.					
Central Vermont	411	\$248,557	\$98,907	\$374,090	\$33,811	\$39,752	\$8,197	\$119,005	\$6,535	\$207,300	\$166,790	\$383	\$20,715	\$146,458	\$27,322	
Missouri Pacific	3,920	1,586,440	462,186	2,244,883	1,21,537	373,221	61,118	937,201	58,243	1,551,320	693,563	-3,764	98,981	590,818	319,863	
New Orleans Great Northern	283	117,308	32,759	161,815	19,925	9,142	2,306	45,338	7,975	84,686	77,129	-81	2,371	74,677	9,938	
St. Louis, Iron Mountain & Southern	3,365	1,762,804	522,218	2,479,941	426,942	428,039	54,054	822,630	22,716	1,754,381	725,560	4,099	125,393	596,068	69,880	
Western Maryland	543	581,931	112,269	729,616	97,311	108,446	16,517	283,958	14,903	521,135	208,481	2,341	20,000	190,822	198,817	
Wheeling & Lake Erie	459	675,412	51,868	765,696	192,341	186,286	7,346	242,069	43,516	671,558	94,138	2,073	32,209	64,002	-159,324	
Central Vermont	411	\$2,776,694	\$1,099,240	\$4,199,047	\$461,502	\$703,075	\$98,725	\$2,004,816	\$97,420	\$3,365,538	\$833,509	\$902	\$176,968	\$657,443	-\$108,473	
Missouri Pacific	3,920	20,528,498	5,155,914	28,018,909	3,814,428	4,853,669	743,648	11,809,090	810,551	22,031,386	5,987,523	-39,410	1,125,711	4,822,402	2,675,817	
New Orleans Great Northern	283	1,300,819	363,230	1,801,343	265,124	165,602	29,788	531,906	80,904	1,073,324	728,019	-721	26,757	700,541	172,509	
St. Louis, Iron Mountain & Southern	3,365	25,219,772	6,471,557	34,136,598	5,448,933	5,006,518	681,520	10,719,358	811,283	22,667,612	11,468,986	-53,594	1,188,638	10,226,754	1,514,913	
Western Maryland	543	6,285,140	996,691	7,644,251	1,089,068	1,087,526	189,110	3,270,016	161,640	5,797,360	1,846,891	2,342	240,000	1,609,233	-501,976	
Wheeling & Lake Erie	459	6,767,830	624,376	7,831,948	1,285,931	1,657,174	98,304	2,609,473	239,757	5,899,639	1,941,309	29,698	362,426	1,608,581	-509,938	

TWELVE MONTHS OF FISCAL YEAR, 1913.

Railway Officers.

Executive, Financial and Legal Officers.

Samuel L. Kamps has been appointed assistant to the vice-president of the Chicago Great Western, with office at Chicago, and will perform such duties as may be assigned to him.

F. C. Uhlman, auditor of the Virginian Railway, at Norfolk, Va., has been appointed assistant general auditor of the Western Maryland, with headquarters at Baltimore, Md., effective September 17.

Jess W. Lillienthal has been elected president, with headquarters at San Francisco, Cal., of the reorganized United Railways of San Francisco, succeeding Patrick Calhoun. Chas. N. Black, formerly general manager is now vice-president; G. B. Willcutt, formerly secretary and comptroller, is now secretary, and A. M. Dahler is treasurer.

Operating Officers.

J. H. Ellis has been appointed acting general manager of the Georgia Railroad, with headquarters at Augusta, Ga., in place of Thomas K. Scott.

W. H. Given has been appointed assistant general manager of the Waterloo, Cedar Falls & Northern, with office at Waterloo, Iowa; effective September 2.

Thomas H. Pindell has been appointed general superintendent of the Chicago, Peoria & St. Louis, with headquarters at Springfield, Ill., to succeed W. C. Hurst, resigned.

S. B. Moore, has been appointed assistant superintendent of the Globe division of the Arizona Eastern, with headquarters at Globe, Ariz., succeeding A. F. Moursund, transferred.

H. M. Taylor, formerly director of construction of the National Railways of Mexico, at Mexico City, Mex., is now general manager of the Brazil Railway, with headquarters at Sao Paulo, Brazil.

W. S. Martin, whose appointment as general manager of the Denver & Rio Grande, with headquarters at Denver, Colo., has already been noted in these columns, was born in December, 1863, at Keokuk, Iowa.

He began railway work in 1878 with the Missouri, Iowa & Nebraska at Keokuk, and was clerk and telegraph operator until February, 1880. Subsequently he was assistant agent and agent at Alexandria, Mo., and during June, 1881, he worked for the Western Union Telegraph Company at Kansas City, Mo. From July, 1881, to January, 1885, he was with the Wabash, St. Louis & Pacific consecutively as operator in the freight office at Keokuk, operator in the dispatcher's office, dispatcher and chief dispatcher at Centerville, Iowa. In February, 1885, he went to the Louisville, Evansville & St. Louis as chief dispatcher, and was made master of transportation in April, 1887. He was appointed trainmaster of the Nashville & Decatur division of the Louisville & Nashville in July, 1889, and four months later was advanced to assistant superintendent of the Nashville division and the Nashville, Florence & Sheffield. Two years later he became superintendent of the Owensboro & Nashville, and in April, 1895, returned to the Louisville & Nashville as superintendent of the Louisville division, being transferred to the superintendency of the Henderson & St. Louis division at Evansville, Ind., in January, 1898. Mr. Martin severed his con-



W. S. Martin.

nection with the Louisville & Nashville in September, 1900, to go to the Denver & Rio Grande as general superintendent; which position he held until April, 1902. He was then from June 1 to December 31, 1902, superintendent of the Southern Railway at East St. Louis, Ill., and Princeton, Ind., and from January, 1903, to June, 1907, was general manager of the Mexican International. He resigned the latter position to return to the Denver & Rio Grande as assistant general manager, and on September 1, was promoted to general manager, as above noted.

J. E. Taussig has been appointed superintendent of transportation of the Texas & Pacific, with headquarters at Dallas, Tex., to succeed Page Harris, resigned to become vice-president of the National Creosote Company at Houston, Tex.

J. R. Hitchcock, acting general superintendent of the Atchison, Topeka & Santa Fe Coast Lines, at Los Angeles, Cal., has been appointed superintendent of the Los Angeles division, succeeding J. B. Galivin, assigned to other duties.

P. G. Walton, formerly assistant superintendent of the St. Louis, Brownsville & Mexico, has been appointed superintendent of the Fort Street Union Depot Company of Detroit, Mich., in charge of operation. The office of manager, heretofore held by G. E. Williams, is abolished.

Otis Weeks, division engineer of the Southern Pacific at Stockton, Cal., has been appointed assistant superintendent of the Salt Lake division, with headquarters at Ogden, Utah, in place of L. Beaman, transferred. George Geiger has been appointed assistant superintendent of the Salt Lake division, with headquarters at Sparks, Nev., to succeed F. W. Easton, transferred.

T. W. McGaw, trainmaster of the Seaboard Air Line, at Savannah, Ga., has been appointed superintendent of the Savannah Terminal division, recently created, comprising the following: All territory east of the West Yard limit board on the Alabama division, and between the North and South Yard limit boards on the South Carolina division, including Hutchinson Island, with headquarters at Savannah. The office of H. B. Grimshaw, superintendent of the Alabama division, has been transferred to Americus.

**Traffic Officers.**

H. P. Attwater has resigned as industrial agent of the Sunset-Central Lines of the Southern Pacific.

H. F. Kern has been appointed general agent of the Southern Pacific at Denver, Colo., succeeding W. K. McAllister, deceased.

C. E. Wharton has been appointed contracting freight agent of the Illinois Central at San Francisco, Cal., in place of J. H. Cosgrove, resigned.

W. A. Morrow, city passenger agent of the Missouri, Kansas & Texas at Waco, Tex., has been appointed district passenger agent at that place.

F. J. Burke, division freight agent of the Texas & Pacific at Dallas, Tex., has been appointed assistant general freight agent, with office at Dallas.

E. D. Moore has been appointed traveling baggage inspector of the Southern Railway, with headquarters at Washington, D. C., succeeding H. H. Little, promoted.

P. M. Havens has been appointed soliciting freight agent of the Cincinnati, Hamilton & Dayton at Indianapolis, Ind., succeeding D. B. Barclay, resigned to engage in other business.

L. M. Brown, chief clerk in the general passenger agent's office of the Denver & Rio Grande, has been appointed assistant general passenger agent, with headquarters at Denver, Colo.

James J. Lawrence has been appointed assistant general passenger agent of the Trinity & Brazos Valley, with headquarters at Houston, Tex., succeeding Sydnor J. Tucker, resigned to accept a position with William P. Bonbright & Company, New York. Effective October 1.

W. C. Staley, general agent of the Missouri Pacific and St. Louis, Iron Mountain & Southern at Chicago, has had his jurisdiction extended over the Denver & Rio Grande and Western Pacific, succeeding F. C. Gifford, who has been appointed agent of the four roads mentioned at Kansas City, Mo.

**Engineering and Rolling Stock Officers.**

G. S. Weiler has been appointed acting general car foreman of the Gulf, Colorado & Santa Fe, with headquarters at Cleburne, Tex., succeeding R. W. Schulze, resigned.

George W. Abbott has been appointed division engineer of the Boston division of the Boston & Albany, with office at South Station, Boston, Mass., succeeding E. A. Haskell, deceased, effective September 2.

L. Beaman, assistant division superintendent of the Southern Pacific at Ogden, Utah, has been appointed division engineer of the Stockton division, with headquarters at Stockton, Cal., succeeding O. Weeks, transferred.

I. S. Downing, master car builder of the Lake Shore & Michigan Southern at Collinwood, O., has been appointed master car builder of the Cleveland, Cincinnati, Chicago & St. Louis and Peoria & Eastern, with headquarters at Indianapolis, Ind. District car foremen will report direct to Mr. Downing. Effective September 1.

J. H. Watters, assistant master mechanic of the Georgia Railroad, at Augusta, Ga., has been appointed master mechanic, with headquarters at Augusta, succeeding John S. Cook, deceased.



J. H. Watters.

He was born September 12, 1851, at Rome, Ga., and was educated in the high school of his native town. He began railway work in 1868 as a locomotive fireman on the Selma, Rome & Dalton, now a part of the Southern, and from 1871 to 1885 was locomotive engineer on the same road. He was subsequently master mechanic of the Anniston & Atlantic, and then until January, 1892, was master of transportation and master mechanic of the same road and of the Anniston & Cincinnati. Both of these roads are now a part of the Louisville & Nashville. In January, 1892, he was appointed

master mechanic of the Louisville division of the Louisville & Nashville, and in October, 1901, went to the Georgia Railroad as assistant master mechanic, which position he held at the time of his recent appointment as master mechanic of the same road, as above noted.

G. W. Lillie, heretofore acting mechanical superintendent of the Rock Island Lines, has been appointed mechanical superintendent of the Second district, with headquarters at Topeka, Kan., succeeding C. M. Taylor, deceased, and George A. Hull, heretofore acting assistant mechanical engineer, has been appointed assistant mechanical engineer, with office at Silvis, Ill., succeeding Mr. Lillie.

John L. Hodgson, master car builder of the Grand Trunk at Port Huron, Ont., has been appointed superintendent of the car department of the Grand Trunk Pacific, with headquarters at Transcona, Man. He was born in 1858 at Simcoe, Ont., and entered the service of the Grand Trunk at Brantford, Ont. In 1884 he was transferred to Toronto, as car foreman, and since 1897 has been master car builder of the same road at Port Huron.

T. W. Coe has been appointed superintendent of shops of the Lake Shore & Michigan Southern, with office at Elkhart, Ind., succeeding W. J. Frauendiener, resigned. J. W. Senger, master car builder, at Englewood, Ill., has been appointed master car builder, with headquarters at Collingwood, Ohio, succeeding I. S. Downing, resigned, to go to the Cleveland, Cincinnati, Chicago & St. Louis. George Thomson, assistant master car builder at Englewood, succeeds Mr. Senger as master car builder at Englewood, and James Reed succeeds Mr. Thomson.



**Purchasing Officers.**

Albert Clinton Mann, who recently became purchasing agent of the Illinois Central, with headquarters at Chicago, as has been mentioned in these columns, was born September 1, 1881, at Effingham, Ill. He was graduated from the high school at Decatur, Ill., in June, 1898, and the following year took a stenographic course at Brown's Business College in the latter city. He began railway work January 10, 1900, as stenographer for a commercial agent of the Illinois Central at St. Louis, Mo., and later was bill of lading clerk in the same office. In February, 1902 he was advanced to secretary to the general agent at St. Louis, and four months later was transferred to Chicago as secretary and clerk to the coal traffic manager. In June, 1904. Mr. Mann entered the purchasing department as secretary to the purchasing agent, and was subsequently price clerk and chief clerk in that department. He was promoted to assistant purchasing agent in January, 1912, and in May of that year was made purchasing agent of the Central of Georgia at Savannah, Ga., which position he held until September 1, when he returned to Chicago as purchasing agent of the Illinois Central, as above noted.



A. C. Mann.

**OBITUARY.**

Frederick C. N. Robertson, auditor of the Pullman Co. at Chicago, died on September 9, at Montreal, Que. He was born July 26, 1848, at Toronto, Ont., and was educated at the Model Grammar School and Upper Canada College. Prior to 1882 he was engaged in banking and accounting in Canada, and since that time had been in the service of Pullman's Palace Car Co., and its successor the Pullman Co. From 1882, when he entered the service of Pullman's Palace Car Co., until 1885, he was assistant to auditor, and during the next two years was assistant auditor. In 1887, he was appointed first assistant auditor and on April 1, 1890, was promoted to auditor.

The accompanying photograph is that of the late John S. Cook, master mechanic of the Georgia Railroad at Augusta, Ga., who died on August 28, at Baltimore, Md., and a sketch of whose life was published last week, page 434. The photograph was received too late for use in that issue. Mr. Cook had been in railroad service 64 years, and he was with one company, the Georgia Railroad, for over 60 years. He had held the position of master mechanic on that road since 1878. He served in the Augusta shops throughout these 60 years, and the present shop buildings were built and equipped under his supervision.



J. S. Cook.

**NEW LINE FOR ARGENTINA.**—The Central Cordoba will build a new line from Cordoba to Mar Chiquita.

**Equipment and Supplies.****LOCOMOTIVE BUILDING.**

THE PHILADELPHIA & READING has ordered 12 consolidation locomotives from the company's shops.

THE TOLEDO, ST. LOUIS & WESTERN has ordered 5 locomotives from the Baldwin Locomotive Works.

THE SAN ANTONIO, UVALDE & GULF has ordered 2 consolidation locomotives and 2 ten-wheel locomotives from the American Locomotive Company. The consolidation locomotives will have 20 in. x 24 in. cylinders, 54 in. driving wheels, and in working order will weigh 140,000 lbs. The ten-wheel locomotives will have 19 in. x 26 in. cylinders, 56 in. driving wheels, and in working order will weigh 140,000 lbs.

**CAR BUILDING.**

THE NORTHERN PACIFIC is in the market for 40 refrigerator cars and 12 seventy-foot baggage cars.

THE BANGOR & AROOSTOOK has ordered 58 flat cars and 13 box cars from the Middletown Car Works.

THE BOSTON & MAINE has ordered 500 gondola cars and 4,500 center sill constructions from the Pressed Steel Car Company, and 500 box cars from the Keith Car & Manufacturing Company.

THE NEW YORK CENTRAL LINES have ordered over 300 passenger cars from the Pressed Steel Car Company, the American Car & Foundry Company, the Pullman Company and the Standard Steel Car Company.

**IRON AND STEEL.**

THE DENVER & RIO GRANDE has ordered 400 tons of bridge material from the American Bridge Company.

THE NORTHERN PACIFIC has ordered 3,000 tons of bridge material from the American Bridge Company.

**GENERAL CONDITIONS IN STEEL.**—The aggregate buying of steel last week was light compared with the previous week. Consumers continue to hold back and orders are placed only for vital requirements. The prices continue to be shaded, although the official quotation has not been reduced. The Steel Corporation is still operating about 90 per cent. of its capacity and is not planning to reduce operations this month. The independent companies are operating at about the same rate of capacity, and their books show sufficient orders to keep them busy until the end of the year. The unfilled tonnage of the United States Steel Corporation August 31, was 5,223,468, a decrease of 175,888 tons as compared with July. This decrease is smaller than was expected.

**PROPOSED LINE FOR PARAGUAY.**—A commission of engineers has arrived at Asuncion, Paraguay, to carry out the surveys for a line from Puerto Suarez to Santa Cruz. This line forms one of those which the Farquhar syndicate proposes to build.

**RAILROAD CONSTRUCTION, ROME TO OSTIA.**—For many years projects have been discussed for building a railroad from Rome to Ostia, the ancient seaport of Rome, which was once a flourishing port at the mouth of the Tiber river, but is now practically a deserted village, infested with malaria and, owing to the continual deposits of silt from the river, is some 2½ miles from the sea. There is, however, a fine beach for bathing, but, although only some 18 miles from Rome, it is practically inaccessible, as the place can be reached only by motor or bicycle. There is no doubt that the projected railroad would do a large business, especially in summer, and the renewal of communications would restore to Ostia some of its former prosperity. Construction of the line has now been approved by the government, and a concession is to be given to the city of Rome. This concession is to be handed over to a French company for execution, but no definite plans have been decided upon regarding the technical and financial details. The work may be started early next year.

## Supply Trade News.

C. H. McCormick, for a number of years connected with the mechanical department of the Michigan Central, has been made district manager of the Standard Heat & Ventilation Company, Inc., New York, with office in Cincinnati, Ohio.

The Metal Treating & Equipment Company, Inc., New York, is just completing a plant at 834 Humboldt street, Brooklyn, N. Y., where job galvanizing work will be done by the improved Standard process of electro galvanizing. This plant will be ready for operation about the middle of September.

A. D. Wyckoff, efficiency expert of S. F. Bowser & Co., Fort Wayne, Ind., with office at Pittsburgh, Pa., has been made eastern railroad representative of that company, succeeding Frank T. Hyndman, who recently resigned to become superintendent of motive power and cars of the Wheeling & Lake Erie. Mr. Wyckoff has been with the Bowser company for a number of years, and has had a wide experience in designing equipment for the handling and storage of oils, as well as oil filtering and circulating systems for railroads and manufacturing institutions.

### TRADE PUBLICATIONS.

**DRAINS.**—The Canton Culvert Company, Canton, Ohio, has published an illustrated folder on its Duro perforated, corrugated metal railway drains, pointing out the advantages of these drains and showing several installations.

**SURVEYING INSTRUMENTS.**—Kolesch & Company, New York, has issued a leaflet describing the Fulton pocket target, a handy and useful article for locating the line from which the plumb bob is suspended over a given point.

**WRECKING HOOK.**—The National Malleable Castings Company, Cleveland, Ohio, has published circular No. 63 on the Goodman wrecking hook. This hook fits any M. C. B. coupler, and can be easily attached to the wrecking cable.

**MALLEABLE IRON CASTINGS.**—The National Malleable Castings Company has published catalog No. 22 of its malleable iron castings for air brake equipment. This catalog is illustrated and gives the various sizes in which these castings come.

**PROTECTION AGAINST CORROSION.**—The Metal Treating & Equipment Company, Inc., New York, has published a booklet entitled, Protection of Iron and Steel Against Corrosion, in which is given an account of the Standard galvanizing process.

**SECOND HAND MATERIAL.**—Herman L. Winterer, Philadelphia, Pa., has published a partial list of his stock on hand available for immediate delivery. This list includes second hand machine tools, engines, boilers, dynamos and motors, pumps, general machinery, etc.

**HIGH GRADE STEELS.**—The Philadelphia Steel & Forge Company, New York, has published an attractive illustrated booklet, entitled, High Grade Steels, giving detailed information on its various products, including bars, strips, hot rolled and cold drawn shapes, wire and forgings.

**ASBESTOSTEEL.**—The Asbestos Protective Metal Company, Beaver Falls, Pa., has published bulletin No. 53, on its Asbestosteel for roofs and walls. This bulletin is devoted to the special use of asbestos protective metal in connection with concrete for construction of roofs and curtain walls. It is well illustrated and describes in a convincing manner the many advantages of this material.

**FLEXIBLE UNIONS.**—The Jefferson Union Company, Lexington, Mass., has published a folder on its flexible union. This is an entirely new product of this company and is designed for use where the steam pressure rises to 250 lbs. and over, and also where pipes are out of line, in which case this union can be used, it is said, in an equally efficient manner as if the pipes were absolutely straight.

**SOUTH AFRICAN RAILWAY CONSTRUCTION BILL.**—A bill has been introduced into the Union Parliament to provide for the construction of 795 miles of railways at an estimated cost of \$13,290,000.

## Railway Construction.

**CAMPBELLFORD, LAKE ONTARIO & WESTERN.**—See Canadian Pacific.

**CANADIAN PACIFIC.**—In connection with the building of the Campbellford, Lake Ontario & Western from a junction with the present Montreal-Toronto line at Agincourt, Ont., to Glen Tay, second track is being built from the point of junction into Toronto. The work involves putting up two new single track bridges, one over the Don river and the other over the West Don river; also the reduction of the present gradient between Wexford and Donlands, Ont. (April 18, p. 925).

Track laying was started on August 18, west of Islington, Ont., on the second track being built from that point to Guelph Junction. The grading is completed to a point west of Cooksville. Between Cooksville and Streetsville there are some large cuts and fills, on which considerable progress has been made. From Streetsville to Guelph Junction the work is also well advanced. The work will be finished this fall. (September 5, p. 436.)

The Railway Commission of Canada has approved the location plans for the extension of the branch line now terminating at Gimil, Man., north, to Riverton, 26.05 miles. They have also approved the location plans of the Snowflake westerly branch for 9.10 miles from sec. 19, tp. 1, range 9, westerly to sec. 14, tp. 1, range 11.

**ELKIN & ALLEGHENY.**—An officer writes that the work under way for some time on the extension northwest to Sparta, N. C., about 40 miles from Elkin, is expected to be finished on a section of four miles this fall. The road is now in operation from Elkin via State Road to Thurmond, 12 miles. (November 22, p. 1013.)

**GRAND TRUNK.**—John Marsch, who has the general contract to build the Southern New England from Palmer, Mass., to the Rhode Island state line in Massachusetts, is said to have ordered the sub-contractors to resume work. (August 22, p. 353.)

**MEMPHIS & PENSACOLA.**—This company, which was organized some time ago to build from Memphis, Tenn., southeast to Pensacola, Fla., about 370 miles, has been reorganized, it is said, and has increased its capital from \$1,000,000 to \$15,000,000. The work was suspended about three months ago, and was resumed recently at Pensacola. John Clancy, Chicago, has been elected president. Byron H. Joy and J. C. McNish, are directors, and will have their headquarters at Pensacola, during the construction of the line. (July 7, 1912, p. 1263.)

**OAKLAND, ANTIOCH & EASTERN (Electric).**—This company began operating trains on September 3, between Sacramento, Cal., and Oakland, 91 miles. The Shepard Pass tunnel, built for this road, located about five miles from Oakland, is nearly two-thirds of a mile long. The distribution system from the railway substations is 1,200 volt d. c., with overhead catenary construction. The power is supplied by one of the large hydro-electric companies whose lines intersect the railway.

**SAN ANTONIO, FREDERICKSBURG & NORTHERN.**—This company has finished work, it is said, on the line from a point on the Kerrville branch of the San Antonio & Aransas Pass, about four miles northwest of Waring, Kendall county, Tex., north to Fredericksburg in Gillespie county, about 25 miles. An officer is quoted as saying that plans are being made to build an extension from Fredericksburg, north via Brady, to Coleman, about 100 miles. R. A. Love, president; F. Crane, vice-president, and A. L. Cunningham, chief engineer. (February 14, p. 314.)

**SAN BENITO & RIO GRANDE VALLEY.**—This company, operating about 65 miles of line, has plans made for building an additional 155 miles. Work was resumed recently, it is said, on an extension to Roma, in the Rio Grande valley, which is about 60 miles west of Mission. The line will eventually be extended to the coal fields of Zapata county. It is said that the property has been taken over by a St. Louis syndicate. (May 2, p. 1013.)

**SOUTHERN NEW ENGLAND.**—See Grand Trunk.

### RAILWAY STRUCTURES.

**BUFFALO, N. Y.**—We are told, that the Terminal Commission of Buffalo has approved the contract and agreement between

the city and the Delaware, Lackawanna & Western, under which the railroad company is to build a passenger and freight terminal on the site of the present station in Buffalo. Under the terms of the agreement work must be begun within three months.

CLEVELAND, OHIO.—D. H. Burnham & Co., architects, Chicago, have submitted to the mayor tentative plans for a new union station and approaches to be built by the New York Central and Pennsylvania lines, to cost about \$17,000,000. Alternative plans are included for a bridge and a subway approach to the tracks, which will be elevated 22 ft. above the present level.

DALLAS, TEX.—It is announced that the contract for the extensive terminals to be built by the Dallas Union Terminal Company at a cost of approximately \$5,000,000, will soon be awarded. The site for the proposed improvements has been acquired: All of the railways entering Dallas are stockholders in the terminal company.

GIBSON, IND.—The New York Central Lines are planning an extensive addition to the yards at this point, including a large transfer station for L. C. L. freight.

HARRISBURG, PA.—An officer of the Pennsylvania Railroad writes that in connection with the improvements contemplated in Harrisburg, and the vacation of several streets to permit the Pennsylvania Railroad to build a freight station and the Cumberland Valley to abolish the grade crossings at Front, Second and Third streets, an ordinance was recently passed vacating certain streets and changing grades of others so as to permit them to pass under the Cumberland Valley tracks. It is understood that when this work is carried out under the ordinance the Cumberland Valley will lay a double track from the Susquehanna river to the passenger station.

KANSAS CITY, MO.—The Kansas City Terminal Company has let the general contract for the station power house for the Union station, now under construction, to the Fogel Construction Company of Kansas City.

PHILADELPHIA, PA.—Bids are wanted, September 19, by Morris L. Cooke, director, department of public works, Philadelphia, for putting up bridges as follows: On Fifty-fifth street under the Philadelphia & Baltimore Central (Westchester & Philadelphia), a double track 3-span steel railroad bridge to have a total length of 88 ft., with concrete abutments; on Tenth street under the Tabor branch of the Philadelphia & Reading, a three-track single span about 90 ft. long, and under the Newtown connecting railroad a double-track single span, both to have steel superstructures and concrete abutments, and at Luzerne street over the Oxford road branch of connecting railway, a 35-ft. concrete arch highway bridge. The cost of the work is to be paid for jointly by the city of Philadelphia and the railroads whose tracks they cross. In addition a bridge is to be built on the line of Eighty-fourth street over Darby creek, the cost to be paid for jointly by Philadelphia and Delaware counties.

RICHMOND, VA.—An officer of the Richmond, Fredericksburg & Potomac writes regarding the construction of a passenger station in Richmond to be built jointly by the R. F. & P., and the Atlantic Coast Line, that while the officers of both these roads favor the construction of such a station the matter has not yet been passed upon and approved by the boards of directors. Plans are being made for a five-story structure, 244 ft. x 108 ft., to be built on Broad street, with a passenger concourse 65 ft. deep and 290 ft. wide. A special building 50 ft. x 200 ft. is also to be put up for baggage, mail and express rooms.

SCHUYLKILL HAVEN, PA.—An officer of the Philadelphia & Reading writes that a contract has been given to P. Campion, Mahanoy City, Pa., for putting up the steel and brick freight house, also the office building at Schuylkill Haven. (August 29, p. 396.)

STRATFORD, ONT.—An officer of the Grand Trunk writes that the company's forces are now at work building the granite and stone passenger station at Stratford. The building is to be two stories high, 72 ft. x 300 ft., and will cost about \$60,000. (August 15, page 314.)

SUPERIOR, WIS.—Plans are being formulated by the Great Northern for the construction of a steel and concrete ore dock at Allouez Bay, to replace the present timber structure.

## Railway Financial News

ATCHISON, TOPEKA & SANTA FE.—The *Commercial & Financial Chronicle* says that stockholders are to vote on October 23 on the question of leasing the Verde Valley Railway and the Dodge City & Cimarron Valley.

ERIE.—White, Weld & Co. and Brown Brothers & Co., both of New York, are offering \$1,120,000 series A 5 per cent. equipment trust certificates, due semi-annually March 1, 1914, to September 1, 1923, and \$1,000,000 series V 5 per cent. equipment trust certificates due annually June 15, 1914, to June 15, 1923, at prices to yield 5.50 per cent. interest on the investment. The series A certificates are issued by the Commercial Trust Company of Philadelphia and guaranteed principal and interest by the Erie and secured by equipment on which the Erie paid 18 per cent. of the total price in cash. The series V are a direct obligation of the Erie and are secured by equipment on which the Erie paid 15 per cent. of the total purchase price in cash.

FLORIDA EAST COAST.—The directors have declared 2½ per cent. on the \$20,000,000 general mortgage income bonds for the year ended June 30, 1913. In 1912 the same rate was paid, and in 1911 4 per cent.

GALVESTON-HOUSTON ELECTRIC.—The directors have declared a semi-annual dividend on the common stock, payable September 15, making a total of 5½ per cent. declared in 1913, as compared with a total of 3½ per cent. paid in 1912.

NEW YORK, NEW HAVEN & HARTFORD.—See editorial comments elsewhere in this issue on the withdrawal of the firm of J. P. Morgan & Company as the sole fiscal agent for the road.

ST. LOUIS & SAN FRANCISCO.—The semi-annual interest, due September 1, on the \$28,582,018 New Orleans, Texas & Mexico division bonds was not paid, and the receivers have made no provision for interest on the \$2,600,000 2-year notes.

SOUTHERN PACIFIC.—Of the \$88,357,600 Southern Pacific certificates of interest offered to Union Pacific stockholders, \$81,005,400 were subscribed for, leaving but about 8 per cent. to be distributed among the 600 members of the syndicate of which Kuhn, Loeb & Company are the head.

RAILWAY ACTIVITY IN NORWAY.—The Norwegian Storting has definitely decided to build a 23-mile state railroad from Noragutu to Skien, on the west coast, the cost of which, it is estimated, will be about \$1,850,000. Five iron bridges with brick abutments will be built, but only Norwegian manufacturers will be allowed to furnish this material. The necessary cars and locomotives are estimated to cost \$103,500. Construction will be started early next spring.

ARGENTINE RAILWAY MERGER.—The public works committee has favorably reported the bill permitting fusion of the Buenos Aires Great Southern and Buenos Aires Western (Farquhar syndicate) under the name of Ferrocarril del Sud y del Oeste Argentino. Little alteration has been made in the bill as approved by the senate. The capital is to be the same as that already recognized by government for the two companies, as well as any new capital that may be invested, the company to build 930 miles of new line to join up various parts of the two systems, and the period is fixed in which this work is to be carried out. A guaranty deposit of \$127,000 is to be made for the faithful carrying out of the new works.

CABLEWAY UP MONT BLANC.—A cableway connecting the Hameau des Pelerins at Chamonix with the Col du Midi is being constructed. It will serve the Pierre Pointue, situated on one of the most frequented routes for reaching Mont Blanc from Chamonix, and will thus facilitate access to the Grands Mulets. The driving plant will be placed in the upper stations of each section, and will consist of an electric motor of 100 h. p. working the driving pulley of the hauling cable by means of gearing. The works are expected to be completed in 1916. The first section from the Pelerins to La Para is now almost ready, but is not expected to be put in service before 1915, when the glacier des Bossons will be reached. The total cost is estimated at \$600,000.

# Railway Age Gazette

PUBLISHED EVERY FRIDAY AND DAILY EIGHT TIMES IN JUNE, BY THE  
SIMMONS-BOARDMAN PUBLISHING COMPANY,  
WOOLWORTH BUILDING, NEW YORK.

CHICAGO: Transportation Bldg. CLEVELAND: Citizens' Bldg.  
LONDON: Queen Anne's Chambers, Westminster.

E. A. SIMMONS, *President.*

L. B. SHERMAN, *Vice-President.* HENRY LEE, *Sec'y & Treas.*  
The address of the company is the address of the officers.

## EDITORS.

SAMUEL O. DUNN, *Editor.*

ROY V. WRIGHT, <i>Managing Editor.</i>	H. H. SIMMONS	E. S. FAUST
W. E. HOOVER	H. F. LANE	F. W. KNABER
B. B. ADAMS	E. A. AVERILL	A. D. CLOUD
E. T. HOWSON	R. E. THAYER	GEORGE L. FOWLER
	A. C. LOUDON	

Subscriptions, including 52 regular weekly issues and special daily editions published from time to time in New York, or in places other than New York, payable in advance and postage free:

United States and Mexico.....	\$5.00
Canada .....	6.00
Foreign Countries (excepting daily editions).....	8.00
Single Copies .....	15 cents each

Engineering and Maintenance of Way Edition and four Maintenance of Way Convention Daily issues, North America, \$1.00; foreign, \$2.00.

Entered at the Post Office at New York, N. Y., as mail matter of the second class.

WE GUARANTEE, that of this issue 10,100 copies were printed; that of those 10,100 copies, 5,400 were mailed to regular paid subscribers and 350 were provided for counter and news companies' sales; that the total copies printed this year to date were 328,650—an average of 8,649 copies a week.

VOLUME 55. SEPTEMBER 19, 1913. NUMBER 12.

## CONTENTS

### EDITORIAL:

Editorial Notes .....	481
Wanted: A Sense of Responsibility and Duty.....	482
*Lehigh Valley .....	484, 545
Brooklyn Rapid Transit .....	485, 543
New Books .....	485

### MISCELLANEOUS:

*An Interesting Transportation System.....	486
The Railway Business Association on Railway Incomes.....	492
*Report on Tyrone Collision.....	494
Master Painters' Association.....	495
*Some Freight Car Troubles; by J. C. Fritts.....	499
*New Western Pacific Ferry Steamer.....	501
*The Armspear Spheroidal Lens.....	502
Foreign Railway Notes.....	493, 494, 502

### MAINTENANCE OF WAY SECTION.

#### EDITORIAL:

Editorial Notes .....	503
The Contracting of Maintenance Work.....	503

#### LETTERS TO THE EDITOR:

*Another Method for Calculating Frog Angles; by J. M. Fair.....	504
Calculating Frog Angles; by S. S. Roberts.....	504

#### MISCELLANEOUS:

Abstract of Engineering Articles Since August 15.....	504
*Daily Time and Material Report Systems.....	505
*Concrete Foundations for Heavy Service Tracks; by F. Auryansen.....	508
*Rail Anchor Testing Machine.....	509
*A Device for Caving Down Banks Ahead of a Steam Shovel.....	510
*A New Quarry Car.....	510
*Concrete Buildings on the Lackawanna.....	511
Action of Alkali and Sea Water on Cements.....	514
The Roadmasters' Annual Convention.....	515
*A Narrow Gage Inspection Motor Car.....	523
*A German Experimental Railroad.....	524
*The Three Men Track Layer.....	525
American Railway Bridge and Building Association.....	526

#### GENERAL NEWS SECTION..... 527

\*Illustrated.

WHILE the transportation system of the United States Steel Corporation, which is described elsewhere in this issue, was established primarily for the transportation of the raw materials of the Corporation, all the units of it except the steamship lines are common carriers competing actively for all classes of traffic. The various units were acquired during a period when the railways were not regulated as they are now, and they were a valuable asset to the mills in their negotiations with the other roads for the handling of their immense traffic. This was especially true of the Bessemer & Lake Erie, which was built by the Carnegie Steel Company several years before the formation of the Corporation. An impression prevails that the Corporation's lines have a monopoly of the transportation of its materials. As indicated in the article referred to, this is not the fact. While a large part of the Steel Corporation's materials is carried by its own transportation system, it is dependent to a large extent upon other lines at every point, so that it has outside conditions to meet. The student of railway operation may draw a number of instructive lessons from this system. In the first place, it is more highly organized and officered than the average railway system. Although subject to one central control, each unit is in charge of an operating officer and staff who devote their entire attention to the one property, and who operate it independently as regards its local problems. This close supervision is carried down to the details of the actual train movements. Few roads provide three despatchers for 225 miles of line, part of which is branch track, or have four trainmasters supervising train movement on the same mileage, as is done on the Bessemer. The handling of an exceedingly heavy tonnage and a considerable passenger traffic on a line not entirely provided with double track, with the remarkable regularity attained by the Bessemer, is an indication of the success resulting from these measures. The loading of all cars to an average of 97 per cent. of their capacity, including overload, is an example of the results gained by supervision of details. It should also be borne in mind that this tonnage is practically all handled in a week of six days, for wherever possible Sunday work is eliminated, and no freight trains are started out of a terminal from Saturday night until Monday morning, although trains on the road are permitted to continue to their terminals.

EQUALLY interesting to a railroad man is the success attending the efforts of the Bessemer to develop a northbound traffic to offset the heavy ore movement southbound, which is in itself an unusual and highly creditable record. From present indications this northbound traffic will equal if not exceed the southbound movement within a couple of years. Another interesting feature which should be noted is the substitution of machinery for labor in the handling of all the ore from the mine to the furnace, although the ore is handled at least five or six times in its movement. From the standpoint of the Steel Corporation, the greatest value of its transportation system consists in the maintenance of a continuity of supply of raw materials with a minimum of storage and rehandling, which it is considered is rendered possible only by complete control of the transportation facilities. The existing flexibility of operation resulting from the possibility of diverting shipments from a congested point and concentrating equipment at such a point, could not be maintained if the system were operated as several entirely independent units. As shown in our descriptive article, the season's schedule of operation of the railroad and the vessels anticipates the demands of the mills, and enables all the properties from the mines to the Union road, serving the furnaces at Pittsburgh, to plan their work and execute it in harmony with this program. The failure of any one unit to do its work on schedule may be exceedingly serious. For instance, if the mills are unable to unload cars, the Bessemer is then unable to deliver cars at the dock for loading, the vessels are delayed in leaving the lower lake ports and in returning to the docks at the head of the lakes, the docks become congested with ore and eventually the steam shovels are forced to

shut down in the pits. The necessity for keeping all facilities in operation is especially urgent on the roads on the Range, for a slight delay will produce congestion and tie up the mines.

THE coroner who investigated the North Haven collision on the New Haven has made a report, holding the conductor and flagman of one train and the engineman of the other responsible, and recommending that they be prosecuted. He attributes the collision to the failure of these employees to obey the rules of the company with which they were familiar. Whether these men should be punished is one question. Whether as a general proposition railway employees whose careless or reckless conduct causes people to be injured or killed should be punished, is another question. The theory of our law is that every one whose misconduct or negligence causes injury or death ought to be punished. This is also the theory of the law in other countries; and in some other countries it is rigorously applied. Professor Cunningham, in his paper on "The Administration of the State Railways of Prussia-Hesse," has told us that on these railways "discipline for infraction of the rules is severe. Guilty employees are not only reprimanded, suspended, fined or dismissed, but in flagrant cases they are imprisoned. In 1910 there were 132 cases of criminal prosecution, and 81 employees were given court sentences." Probably on no other leading system of railways are there so many infractions of rules resulting in serious accidents as on the railways of the United States. Seldom, however, has it been found practicable to get prosecutors to prosecute or juries to return verdicts against railway employees whose misconduct has caused accidents. The public and public officials in this country seem to think that the railway employee who has caused an accident is a proper object, not of prosecution, but of sympathy. They appear to assume that his action must have been due to his environment, or to inherited traits, and that, therefore, the society into which he has been born, or the railway by which he is employed, or the grandfather or great-grandfather from whom he inherited his characteristics, should be indicted. Instead of demanding that employees shall not cause accidents, they demand that the railways shall be so equipped that when employees do cause accidents, they will not kill so many people. The theory of the law is that crime is personal, and that a man should be assumed to know and be responsible for the probable results of his own acts. The theory of the public and of public officials, apparently, is that an engineman or a flagman is an infant or automaton who does what he does and fails to do what he fails to do because of the operation of forces within and without him over which he has no control. "It may be," said Professor Cunningham in reference to the Prussian-Hessian state railways, "that the methods there employed to investigate accidents and mete out punishment to the careless have a direct bearing on their remarkable immunity from casualties." In England the methods of investigation and punishment are very similar, and there, as in Prussia, we find the same remarkable immunity from accidents. It may be that the principles according to which the Prussians and the English act are harsh and cruel. It may be that they are wrong in assuming that the railway employee, like other men, is responsible for the results of his own acts and that he, and not his ancestors, or the society into which he happens to have been born, or the railway whose rules he has violated, should be punished. But can a rational mind conclude that there is no significance in the fact that in Prussia and England, where, as we have seen, such rude and antiquated conceptions of individual responsibility and duty obtain, the number of accidents due to the failure of railway employees to perform their duty is extremely small, compared with the number due to the same cause in the United States? Until comparatively recent years the railway problem which attracted the most attention in this country was that of rebating. That practice has now been almost extirpated. How was this done? It was done by public opinion and the law refraining from wasting maudlin sympathy on the individuals who gave and received the rebates, and be-

ginning to prosecute and punish, not only the railways and industrial concerns with which they were connected, but the individuals themselves. Is there or is there not a lesson regarding railway accidents in the United States in the experience of Prussia and England in dealing with railway accidents and in our own experience in dealing with railway rebating?

#### WANTED: A SENSE OF RESPONSIBILITY AND DUTY.

TO the reflecting mind such accidents as the recent one on the New Haven and the hysterical investigations and discussions of it do not suggest merely the question, What is the matter with American railways? They suggest the much broader and deeper question, What is the matter with the American people? The accident record of the railways of the United States is bad. But it is not the railways alone that are killing people. The factories are killing them. Preventable diseases are killing them. Automobiles are killing them on every city street and country road. The man who doesn't know that the gun with which he is fooling is loaded, and the man who knows that the gun he is carrying is being carried contrary to law, are killing them. Homicides, and accidental deaths hardly, or not at all, distinguishable from homicides, have become so prevalent in Chicago that the coroner has organized a commission on public safety composed of prominent citizens to investigate the causes and remedies for all such fatalities. Coroner Hoffman seems to be one of the very few people in this country who have grasped the vital and fundamental fact that fatalities due to railway accidents, automobile accidents, industrial accidents and murder, are all species of one genus. They are all traceable to the same underlying cause, and, therefore, should all be studied and dealt with in much the same manner. To state the matter in another way, railway accidents in the United States are not, as is so commonly assumed, a disease, but merely a symptom, a manifestation of a disease which is eating like a cancer into American life. That disease is an almost universal carelessness and recklessness of conduct on the part of almost all classes of people, and it is due, first, to a lack of a sense of individual responsibility and duty, and second, to a lack of machinery, or of efficient operation of the machinery, for compelling those who have no adequate sense of responsibility or duty to assume their responsibility and do their duty.

That the sense of individual responsibility and duty is wanting is shown by the fact that almost every time a homicide or an accident occurs, everybody who contributed to it begins, not hypocritically, but seriously and honestly, to try to show that the blame for it rests on some other person or persons, or on society as a whole. That the machinery for fixing responsibility and applying preventive and punitive remedies does not exist or has broken down, is shown by the fact that terrible preventable crimes and accidents of all kinds continue to occur, and that usually nobody is brought to book for them. Very commonly the only thing they lead to is a deal of inane and insane clamor, and, unfortunately, the clamor is participated in not only by those who cannot be expected to know the causes and remedies, but also by those who ought to know them. After the New Haven wreck not only did the newspapers publish innumerable news articles and editorials which showed that the writers knew nothing about the causes and remedies of railway accidents, but, unless they were grossly misquoted, some high public officials charged especially with the duty of studying and regulating railway operation gave expression to ideas and sentiments that were adapted grossly to mislead public opinion and to produce no effect on accidents. One of the suggestions attributed to certain high regulating authorities was that the rules should prohibit trains from making up lost time. If enginemen cannot now be got to obey the rules requiring them to run with their trains under control in fogs, and to stop at stop signals, how are they to be got to obey a rule

prohibiting them from making up lost time? And if this proposed rule ought to be enacted into law, as has been intimated, why ought not all rules pertaining to safety? And if they were, and employees violated them, against whom should the laws be enforced—the railway that told its enginemen to obey the law, or the enginemen that broke it?

The lack of the proper sense of individual responsibility and duty which is really at the root of the causes of railway accidents runs through all classes of persons. The financiers who hold railway purse strings often interfere with the operation of the properties, compelling reductions in expenses which are contrary to the sound judgment of the operating officers and causing the physical facilities to be impaired and the lines to be under-officered, without any apparent realization of the fact that there is any connection between their vicious financial policies and the long roll of railway casualties. The active managers ought stubbornly to resist such ignorant and short-sighted meddling, but they do not always do so. They often proceed on the assumption that the responsibility for unsafe reductions of expenditures rests entirely on those who order them. Likewise, the active managers ought perseveringly and courageously to put forth every effort to so select, train and discipline subordinate officers and employees as to reduce to the minimum the careless and reckless conduct of employees which is the cause of a very great majority of all casualties, except those to trespassers. Every accident caused by the ignorant, careless or reckless conduct of an employee is an indictment of all his superiors, from those with whom he comes in direct contact up to the chairman of the board and the board of directors, and of each of them individually. Do railway officers generally feel this fact as keenly as they should and act accordingly? The answer is the admitted lack of discipline among the employees of American railways. The conditions on some roads are better than on others. But where is the manager who dares say that discipline on his road is as satisfactory as it could be and ought to be made?

When we turn to the employees, especially those concerned with train operation, we find a most deplorable absence of a sense of responsibility and duty. The engineman who carelessly runs past a signal and kills a score of people is never to blame, according to his own notion; the road is to blame; it should have provided automatic stops. Or the flagman is to blame; he should have flagged better. Or the superintendent or the general manager is to blame; he insisted on trains running on time; and, obviously, the superintendent or general manager should insist on trains always running behind time! And, of course, the flagman is never to blame; it is always the engineman, or the weather, or the management. The evidence may show that the engineman or flagman, whose failure to obey a rule or order caused a catastrophe, had been habitually taking chances in violation of rules and orders. Does this lead other enginemen and flagmen to feel a greater sense of responsibility and duty and to stop taking chances? Apparently not. Again and again terrible disasters have been shown to be due to such causes, and yet, while fully knowing this, employees keep right on taking chances.

Congress and the Interstate Commerce Commission are quite as efficient at "passing the buck"—not to say "bunk"—and at not doing anything really to stop accidents. They control how much railways may earn, and therefore how much they may spend to increase safety, and they are using their power to control railway earnings in a way that directly tends to prevent the roads from being adequately officered and from making needed physical improvements. The commission has had authority for years to investigate and make recommendations regarding accidents. It knows, and members of Congress who discuss railway accidents ought to know, that a vast majority of the fatalities are not due to defects of the physical structures and equipment, but to a lack of discipline on the part of employees and to trespassing

on railway property; yet, Congress and the commission have done almost nothing to improve these conditions. When, however, a serious accident occurs, members of Congress and the commission, forgetful, apparently, of the fact that they have a responsibility that they have not lived up to and a duty that they have not performed, immediately busy themselves with accusatory statements about, and investigations of, the railways. The Washington correspondent of one of the Chicago newspapers wired to his paper soon after the New Haven accident that Commissioner McChord of the Interstate Commerce Commission started the "safety first" movement on the railways. He could have said with equal accuracy that Commissioner McChord discovered the circulation of the blood or invented the solar system. Neither Mr. McChord nor anyone else connected with the commission had anything to do with starting the "safety first" movement. It was started by R. C. Richards, general claim agent of the Chicago & North Western. The commission has been so concerned about fixing the responsibility for accidents on the railways, and getting legislation, at the instigation of the railway brotherhoods, and of its accident investigators and safety appliance inspectors, who belong to the brotherhoods, to compel the roads to spend money, that it has had little time to do anything to really promote safety.

The state legislatures and railway commissions have been in the same boat with Congress and the interstate commission. They have compelled the railways to increase the size of their train crews, to use high power headlights and to do many other things that the railway brotherhoods have wished done, but the influence which they have exerted on railway safety has been negligible, except when it has been used in the wrong direction. Repeatedly the fact has been brought to the attention of the various railway regulating authorities that more than one-half of all the persons annually killed on railroads are trespassers, but from one end of the United States to the other there does not seem to be a single man of influence in public office who can be induced to take any interest in the more than 5,000 people who are annually slaughtered while trespassing on railway property. Their blood is on the heads of the lawmakers and the administrative public officials of America; but apparently they don't mind that so long as the railways continue to kill enough passengers to give them material for anti-railway agitations that will carry them into and keep them in office.

The press, by educating public opinion in regard to the causes of and remedies for accidents, could do a great deal to reduce their number. Unfortunately, the press makes very little effort to do so. The misleading news and comments that most newspapers publish regarding accidents more than neutralizes the effect of the correct news and sane comment that they sometimes publish. Here, again, the trouble is a lack of a sense of responsibility and duty. Obviously, it is the duty of the press to spare no effort to get the facts about accidents, and to publish news and comment regarding them which will present the situation to the public in its true proportions. But how many newspapers or other publications of general circulation do this? Because so few do it the American people no more know about the facts about railway accidents in the United States than they know the facts about the moral and religious conditions in Mars. Is it any wonder, in these circumstances, that the regulation of railways which the public causes, permits or condones has almost no tendency to reduce accidents?

Railway financiers, railway officers, railway employees, legislatures, railway commissions, the press and the public, all have their responsibility and duty in connection with railway accidents. Will there ever come a time when not merely a few of them, but all, will awaken to a sense of their real responsibility and begin fully to perform their duty? Until they do the railway accident problem will not be solved. It is not to be solved by railway officers accusing the em-

ployees, by employees accusing the managements, by public officials using accidents as a means of advertising themselves as saviors of the country or by the press using them as a means of increasing their circulation on the West Side of Chicago and the East Side of New York. Whether the sense of responsibility and duty which is necessary to reduce railway accidents can be developed without the development of the broader and more fundamental sense of responsibility and duty which is necessary to reduce homicides and all the various classes of deaths by violence in this country seems very questionable.

LEHIGH VALLEY.

WITH considerably more business in the year ended June 30, 1913, than in the previous year, the Lehigh Valley spent even more proportionately for maintenance, but succeeded in reducing the ratio of transportation expenses to total operating expenses from 34.16 per cent. in 1912 to 32.51 per cent. The increase in expenditures for maintenance of way was \$1,731,000, making the total for this account in 1913 \$5,694,000, or \$3,856 per mile of road. The increase in the amount spent for maintenance of equipment was \$1,248,000, making the total in 1913 \$7,561,000. It is true that the total tonnage of freight carried was 15 per cent. greater in 1913 than in 1912; but presumably this did not greatly affect maintenance costs, and the heavy expenditures for maintenance were, in large part, due to renewals and extensive replacement of old construction and equipment with new permanent structures and more modern rolling stock. Of course, the additional cost of such improvements is charged to capital account; but the entire cost of replacement in kind is charged to maintenance, so that an extensive program of betterment is generally reflected in materially increased maintenance expenses.

The reduction in the transportation ratio in the face of present labor conditions and the retroactive award in the firemen's wage controversy, etc., is worthy of note. The Lehigh Valley

is now a double track road from Buffalo to New York. Extensive improvements and additions have been made in recent years and the plant is in shape to handle economically considerably increased business. Furthermore, the increase in business last year, while good in merchandise, was particularly large in the coal freight business. This was in part, of course, because conditions were not even normal in 1912; but from whatever cause, it probably helped the management to make a good showing in transportation costs. It also increased the average loading per loaded car and helped to give a larger average train load. The Lehigh Valley's car loading per loaded car averaged 24.42 tons in 1913 and 22.84 tons in 1912, and the train load, 599 tons in 1913 and 566 tons in 1912.

Notwithstanding the higher operating ratio—67.62 per cent. in 1913 and 66.98 per cent. in 1912—due to larger maintenance charges, net income, after the payment of fixed charges, was \$8,762,000 in 1913, as against \$6,813,000 in 1912. Dividends at the rate of 10 per cent. called for \$6,061,000. While the company had, therefore, only slightly more than enough to meet its dividend requirements in 1912, it showed a surplus in 1913 of \$2,700,000. The table at the end of these remarks shows in more detail the income account of the company.

The Lehigh Valley is in a particularly strong position as regards cash and working liabilities. Working liabilities at the end of 1913 totaled but \$5,349,000, while cash on hand amounted to \$13,149,000 and total working assets, including cash, to \$37,626,000. Although the company spent \$6,508,000 for additions and betterments (capital account), capital obligations were reduced by the retirement at maturity of \$2,015,000 equipment trust certificates.

There are probably few roads in the entire country that could spend for additions and betterments more than 10 per cent. of the total book value of their property without either issuing new securities, borrowing on short term notes or otherwise, or depleting its working capital. The Lehigh Valley management was farsighted in providing against the present money stringency, and while a good many roads have, especially during the past year, had necessarily to defer extensive betterment work, the Lehigh Valley was able to carry on its program without any modification. This fact is of importance in consideration of the present comparative value of different railroad securities. A road like the Lehigh Valley, which has no accumulated program of improvement or additions, will be in a particularly good position not only to handle the business that will come with the normal increase in coal consumption and in the shipment of manufactures and merchandise, but will also be in a good strategic position in regard to the use which it can make of further increased earnings.

Last year was a good test as to how economically the Lehigh Valley could handle its freight, and total transportation expenses, including the expenses which properly belong to the cost of handling passenger business, per ton per mile were 2.41 mills. The ratio of passenger revenue to total operating revenues varies from year to year between 11 and 12 per cent. The Lehigh Valley gets an average of 6.32 mills per ton per mile and gets an average haul of 180 miles. The following

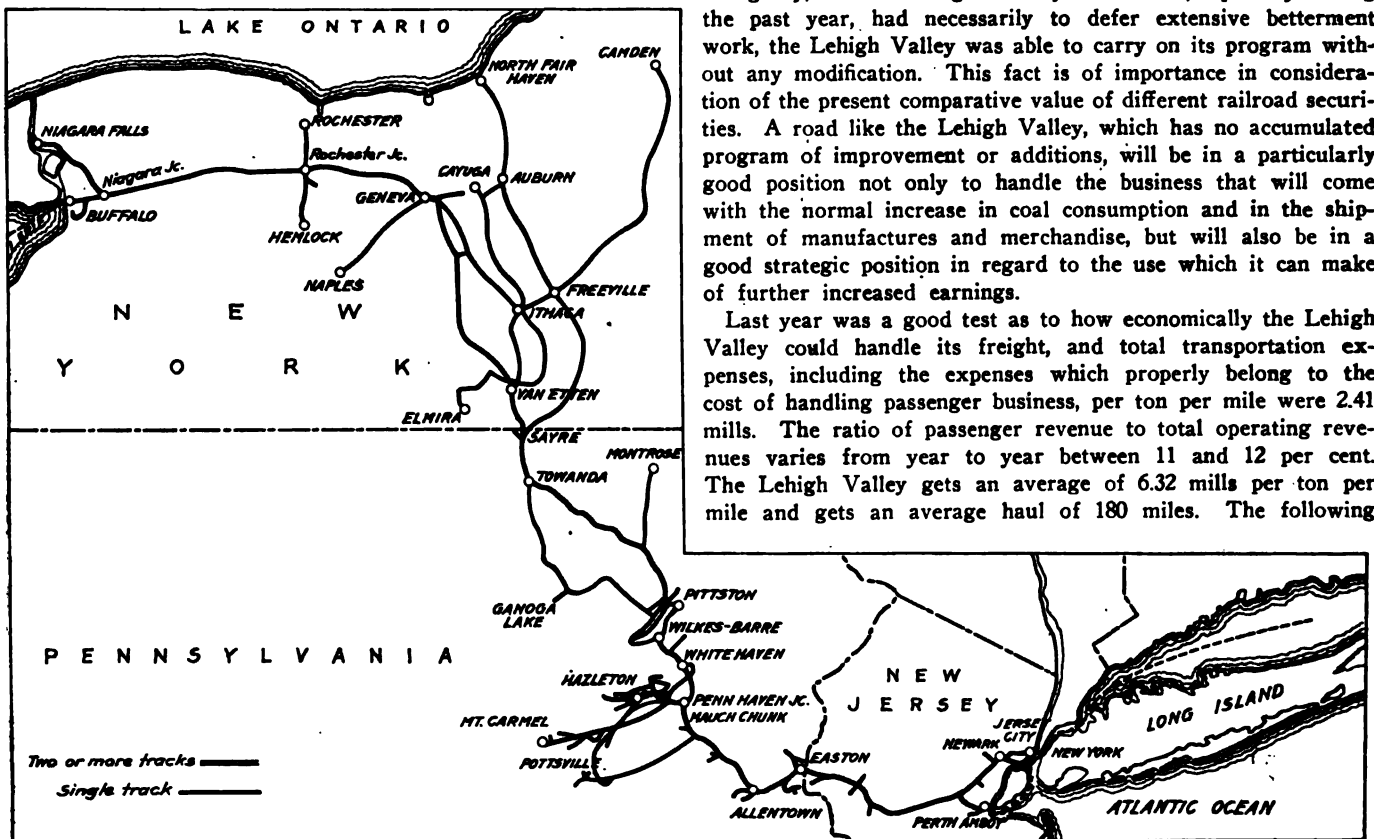

The Lehigh Valley.

table shows the per cent. of each class of expenses to total operating revenues:

	1913.	1912.
Maintenance of way and structures.....	13.23	10.74
Maintenance of equipment.....	17.57	17.11
Transportation expenses.....	32.51	34.16
Traffic expenses.....	2.28	2.65
General expenses.....	2.03	2.32

As an indication of the way in which transportation expenses were held down, fuel per freight locomotive mile was 244 lbs. in 1913, as against 250 lbs. in 1912; water supply cost 0.60 cents per locomotive mile in 1913 and 0.64 cents in 1912; engine house expenses, 2.28 cents in 1913 and 2.33 cents in 1912; and locomotive miles run per pound of waste increased from 73.30 per cent. to 80.37 per cent.

The following table compares the principal figures for operation in the fiscal year ended June 30, 1913, with the 1912 fiscal year:

	1913.	1912.
Average mileage operated.....	1,451	1,441
Coal freight revenue.....	\$20,385,389	\$16,301,316
Merchandise freight revenue.....	16,339,749	14,591,240
Passenger revenue.....	4,867,554	4,703,734
Total operating revenues.....	43,043,372	36,905,935
Maint. of way and structures.....	5,694,422	3,963,589
Maint. of equipment.....	7,561,271	6,313,317
Traffic expenses.....	982,858	980,117
Transportation expenses.....	13,993,617	12,606,962
General expenses.....	875,651	856,266
Total operating expenses.....	29,107,820	24,720,250
Taxes.....	1,447,205	1,312,012
Operating income.....	12,208,137	10,582,434
Total income.....	14,511,892	12,698,896
Net income.....	8,761,828	6,813,020
Dividends.....	6,060,800	6,060,800
Surplus.....	2,701,028	752,220

**BROOKLYN RAPID TRANSIT.**

THE operation of the Brooklyn Rapid Transit is a unique problem, in that it combines the operation of electrified steam lines over private right-of-way; elevated lines, which were originally built for and operated as steam lines; and city surface railways. In all, there are 241 miles of first track operated and a total of 544 miles of all tracks, including turn-outs. To this there will be added about 240 miles of additional track when the subway extensions into Manhattan have been built, in accordance with the plans for the New York so-called dual subway and elevated system. Beside having very many of the same problems of operation, of relations with its employees, etc., that a steam road has on its suburban business, the Brooklyn Rapid Transit, of course, in its relations with the public it serves, is in a position closely analogous to that of a steam road serving a suburban population.

Since, however, the average figures are a combination of so many different kinds of figures, their chief interest lies in the results that the total shows, and it is quite impossible from the combined figures to form any idea of the operation of any separate part of the property. Security holders of the B. R. T. and railroad men who are interested in what this company may do when it comes to competition with the Interborough Rapid Transit, are, therefore, left largely to form their opinion of the future from the net results that are being shown in the present.

In 1913 the B. R. T. earned gross from operation \$24,152,000, an increase of \$926,000, or about 4 per cent., over 1912. This is very close to the normal increase which has taken place from year to year since 1902. During those 12 years the gross earnings have not quite doubled. In 1913 the company earned net, after paying operating expenses, \$11,659,000. This is an increase of 6.6 per cent. in net, and whereas gross has not quite doubled in 12 years, net has almost tripled. Net income, after the payment of fixed charges and taxes, amounted to \$4,497,000 in 1913, which is more by \$786,000, or 21 per cent., than in the previous year. During the last quarter of the year the company increased its annual dividend rate from 5 per cent. to 6 per cent.; but even with the somewhat larger dividend payments, the company showed a credit to profit and loss on its balance sheet at the end of 1913 of \$7,905,000, which is greater by \$2,041,000 than that shown at the beginning of the year.

Some idea of at least the results which the company is obtaining may be had from a study of the comparative statistics for the years 1902-1913 inclusive. During that period the passenger earnings per passenger have decreased slightly, being 3.83 cents in 1902 and 3.74 cents in 1913. Total operating charges, however, have decreased from 2.57 cents per passenger in 1902 to 2.05 cents per passenger in 1913; the 1913 figure being the lowest in the company's history and comparing with 3.08 cents, the best previous showing, made in 1910, and 2.11 cents in 1912. The proportion of total operating earnings spent for repairs and renewals has increased from 15.81 per cent. in 1902 to 16.39 per cent. in 1913, while general operating expenses, which correspond very roughly with transportation expenses on a steam road, have decreased from 42.85 per cent. in 1902 to 33.53 per cent. in 1913, the 1913 figure being the lowest in the company's history and comparing with 33.89 per cent., the lowest previous figure, made in 1912. Damages, which in 1902 cost the company 6.88 per cent. of total operating revenues, have been continually and consistently hammered at, until in 1913 these expenses amounted to but 2.51 per cent. of the total earnings. This compares with 2.95 per cent., the figure made in 1912, which was the best theretofore in the company's history.

The annual report of the Brooklyn Rapid Transit this year is of particular interest because it gives, if not the first comprehensive, at any rate the first condensed and easily comprehensible summary of the Brooklyn Rapid Transit's program for its share of the new subways and elevated lines that are to be built to comprise the dual system which has during the past year been approved by the Public Service Commission and New York City. Of the B. R. T.'s 544 miles of track, all of the elevated, except that on the Brooklyn and Williamsburg bridges and, in addition, 56 miles of surface track, are to be combined with the lines which the city is to build, about 133 miles, with certain trackage rights and extensions to make the new 293 miles of the Brooklyn Rapid Transit's part of the dual system. The lines which are to be built by the city will cost, it is estimated, about \$100,500,000, and are to be leased to the B. R. T. for 49 years, beginning January 1, 1917, and are to be equipped by the B. R. T.\* at an estimated cost, including the extension of present lines, of \$65,000,000.

The net revenue, after the payment of operating expenses, taxes and depreciation, of the entire new system (293 miles) is to be divided as follows: The Brooklyn Rapid Transit is to get \$3,500,000, representing the net earnings of existing roads (presumably the elevated), which it contributes to the new system; the B. R. T. is to get 6 per cent. on its new investment of \$65,000,000 prior to the beginning of permanent operation "and thereafter interest and 1 per cent. sinking fund"; the city is to get "interest and 1 per cent. sinking fund on its investment in cost of construction"; the remaining surplus is to be divided equally between the lessee and the city.

**NEW BOOKS.**

*American Society for Testing Materials Index.* Published by the American Society for Testing Materials, University of Pennsylvania, Philadelphia, Pa. 158 pages, 6½ in. x 9 in. Cloth, \$1.50; leather, \$2.

This index covers the contents of Vol. I-XII, inclusive, of the proceedings of this association, excluding only those portions relating to routine business. Vol. I contains the 28 bulletins issued at irregular intervals from 1898 to 1902. From the latter date the proceedings have been published annually. Titles of individual papers are distinguished from committee reports and specifications. A list of key words under which the various subjects are indexed appears in the front of this volume, and the index is also classified under subjects and authors.

\*The Brooklyn Rapid Transit is not legally or technically the lessee of the operating company of the new system. The New York Consolidated Railroad Company was formed to operate the new system and all of the stock of this company is owned by the B. R. T., and its securities and the securities of its subsidiary companies are guaranteed by the B. R. T.



# AN INTERESTING TRANSPORTATION SYSTEM.

The Lines of the U. S. Steel Corporation Form a Complete Chain from the Minnesota Mines to the Pittsburgh Mills.

The transportation system developed by the United States Steel Corporation for the movement of ore from the Minnesota ranges to the mills in the Pittsburgh and Chicago districts is an exceedingly instructive one to persons interested in efficient transportation methods. The high point to which this system has been developed as a transportation organization for commercial as well as for corporation traffic, the close correlation of the various units to produce regularity of operation and the elaborate meas-

ures adopted to secure economy of operation, afford many details of interest to railway men. The principal units in this system are the Duluth, Missabe & Northern Railway, extending from the Missabe range in the vicinity of Hibbing and Virginia, Minn., to the docks at Duluth; the Duluth & Iron Range Railroad, extending from the Vermilion range, in the vicinity of Ely, Minn., and also from the Missabe range to docks at Two Harbors, with a branch along the lake to Duluth; the Pittsburgh Steamship Company, operating between the Lake Superior docks and Lake Erie and South Chicago ports; the Bessemer & Lake Erie Railroad, extending from Conneaut Harbor, O., to North Bessemer, Pa., at the entrance to the Pittsburgh district; the Union Railroad, which performs a switching service between North Bessemer and the various mills located on this road and connecting lines in the Pittsburgh district, and the Elgin, Joliet & Eastern Railway, which performs a similar service in the Chicago district. The railway lines of the Corporation alone comprise 976 miles of main track and own 47,500 cars and 1,203 locomotives.

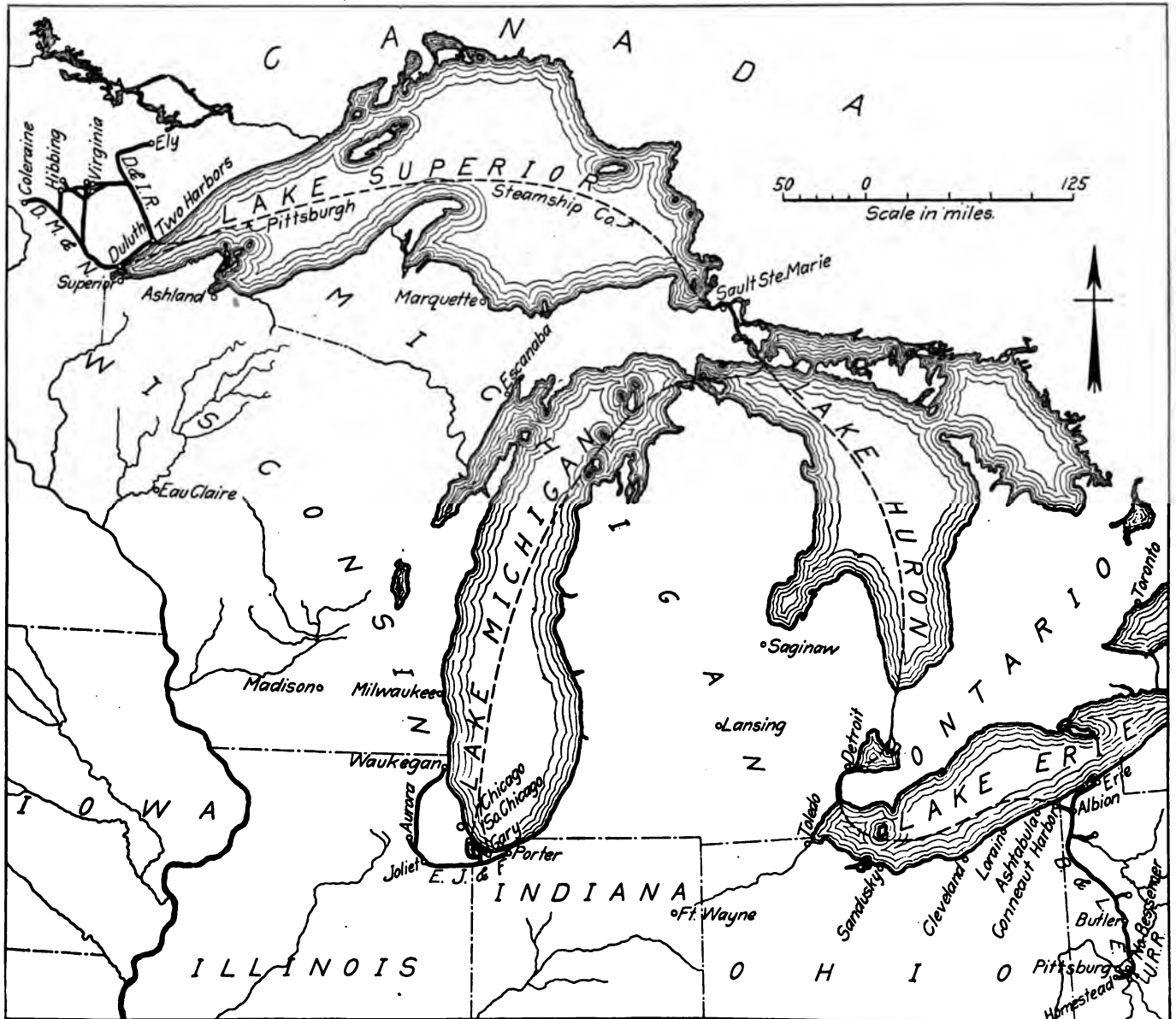

Fig. 1—Map of Rail and Boat Lines of the Steel Corporation.

ures adopted to secure economy of operation, afford many details of interest to railway men.

The principal units in this system are the Duluth, Missabe & Northern Railway, extending from the Missabe range in the vicinity of Hibbing and Virginia, Minn., to the docks at Duluth; the Duluth & Iron Range Railroad, extending from the Vermilion range, in the vicinity of Ely, Minn., and also from the Missabe range to docks at Two Harbors, with a branch along the lake to Duluth; the Pittsburgh Steamship Company, operating between the Lake Superior docks and Lake Erie and South Chicago ports; the Bessemer & Lake Erie Railroad, extending

While this system handles the greater part of the ore and other products of the Corporation, in no district is the Corporation independent of other transportation lines. On the Minnesota ranges, the Great Northern handled 14,000,000 tons of ore last year, while large quantities of Corporation ore were loaded at Ashland, Marquette, Escanaba and other Lake Superior ports, all of which was brought to the docks by independent roads. On the lakes the Pittsburgh Steamship Company is able to carry only 60 per cent. of the Corporation's ore, and it is necessary to charter other boats by the season or trip to carry the remaining 40 per cent. Likewise, large quantities of ore are hauled by the

Pennsylvania, Baltimore & Ohio, Lake Shore and other roads from Cleveland, Lorain, Ashtabula and other lower lake ports to the mills.

For the purpose of this study, that portion of the transportation system from the Missabe range via Duluth and Conneaut Harbor to the Pittsburgh district will be discussed as typical of the entire system. This study is especially interesting at the present time in view of the unusually large amount of ore which is now being handled. The tonnage loaded on all the ranges in the Lake Superior district last year was 48,221,546 tons as compared with 32,793,130 in 1911 and 43,442,397 in 1910, the latter being the previous high record. The shipments so far this season equal those for the corresponding part of last year, and for the entire year probably will exceed those of last year. Of the shipments for 1912, 32,047,409 tons, or 66 per cent., from the Lake Superior district came from the Missabe range. The ore from this range is carried to the lake by three roads, the Duluth, Missabe & Northern, the Duluth & Iron Range and the Great Northern. Because of the desire of the Steel Corporation to mine as

development of the mines including the stripping of the pits or the driving of the shafts and all operations to and including the loading of the ore on cars are handled by this company. Much the larger part of the ore mined on the Missabe range is taken from open pits, the operation of which is very largely a railway problem. The ore is usually found in deposits averaging 100 ft. thick, covered with an overburden of sand and gravel averaging about 45 ft. in depth, although in some cases pits have been stripped to a depth of 150 ft. By means of test pits the mining companies are able to determine whether the extent of the ore deposit and its quality will justify the expense of removing the overburden and mining in open pit, or it will be more economical to adopt the underground method of mining or an intermediate process known as milling. When it has been decided to operate a property as an open pit, the stripping is handled in practically the same way as a gravel pit is operated.

As soon as a body of ore is exposed, shovels are started loading the material. It is quite common for stripping and mining operations to be carried on simultaneously, and at some of the



Fig. 2—A Typical Pit in the Missabe District with Circular Approach.

much ore as possible from the Great Northern properties before the expiration of the lease on these mines, this road handled an exceptionally large proportion of this traffic last year.

LOADING THE ORE.

At the beginning of each season a schedule of the ore requirements of the various mills showing the amounts of the various grades of ore needed, and its distribution throughout the year, is prepared. From this schedule an allotment is made for each mine, based upon its facilities and qualities of ore. The various docks of the Corporation and the steamship lines are furnished with copies of this schedule showing what will be expected of them. The different parts of the system then cooperate in moving the proper quantities of the different grades of ore from the mines all the way to the furnaces at the times specified. When one considers the number of mines shipping ore, the number of mills to which this ore is distributed, the fact that over 200 grades of ore are shipped from the Missabe and Vermillion ranges alone, and the different facilities required for handling the ore, the extent and complexity of this schedule are evident.

The mines of the Steel Corporation at the head of the lakes are owned and operated by the Oliver Iron Mining Company. The

larger mines 15 to 20 shovels may be operated at one time. Ninety-ton shovels with 2½ yd. buckets are generally used. Whenever possible, an idle shovel is kept under steam in each mine so that in case of a break-down of one of the shovels, the reserve shovel may be run in and the trains be kept moving. The average output from a shovel is about seventy-five 50-ton cars in a 10-hour shift, although record runs of 180 cars in the same length of time and 380 cars in two shifts have been reported by individual mines.

Because of the temporary nature of the tracks leading to the shovels it is not ordinarily possible for a loading track to be located so as to have an outlet at both ends. Switches are placed, however, so that the waiting train of empties can be set as near the shovels as possible. The arrangement of tracks from the approach down to the various shovels may consist either of a series of switchbacks, or a continuous grade with loops or circles to keep it within the restricted area of the pit.

A car trimmer at each shovel is responsible for the trimming of the load on each car so that no ore will be lost in transit. This man also tags each car with a card showing the name of the mine and the number of the shovel, and a waybill is made out, giving the grade of the ore, the name of the mine and the



Fig. 3—An Illustration of the Number of Levels in an Open Pit Mine in the Missabe District.

date of shipment, as well as the weight after the car reaches the scales. When the pit trains reach the assembling yard the loads are set in on a track reserved for that particular ore, this being the first step in the classification of the material. A representative of the mining company's testing department takes samples from each car which are tested immediately, and the results of the tests are used in further classifying the ore before it reaches the dock.

The ore cars generally used are of 50 tons capacity with a short wheel base and are of the bottom dump type. Double hopper steel cars are probably in the majority at the present time. The engines used in the pits vary considerably in weight and tractive effort, but a typical locomotive of recent design used by the Oliver Iron Mining Company weighs 124,000 lbs. and has a tractive effort of 28,720 lbs. A number of larger engines weighing 152,000 lbs., with a tractive effort of 33,590 lbs. are also used.

The loaded ore cars in the pits are usually handled in trains of

tribution of empty cars, and also so that the pit boss can be advised of any delay in securing cars which will affect the operation of his mine.

The tracks in an open pit mine are laid and maintained by the mining company, the material being furnished by the railway serving that particular mine. As an example of the magnitude of the track facilities required, there are at present about 37 miles of track in the Hull-Rust mine, the largest on the range. The most common grade for the approach tracks is two per cent., although lighter grades are used wherever possible, and in numerous cases heavier grades have to be adopted. Curves of 15 deg. are usually considered maximum, although 28 deg. curves are not infrequent and one 40 deg. curve is reported.

#### THE DULUTH, MISSABE & NORTHERN.

The Duluth, Missabe & Northern maintains two principal engine terminals on the range. The output of the mines is such that it is usually able to send an engine out to pick up a com-

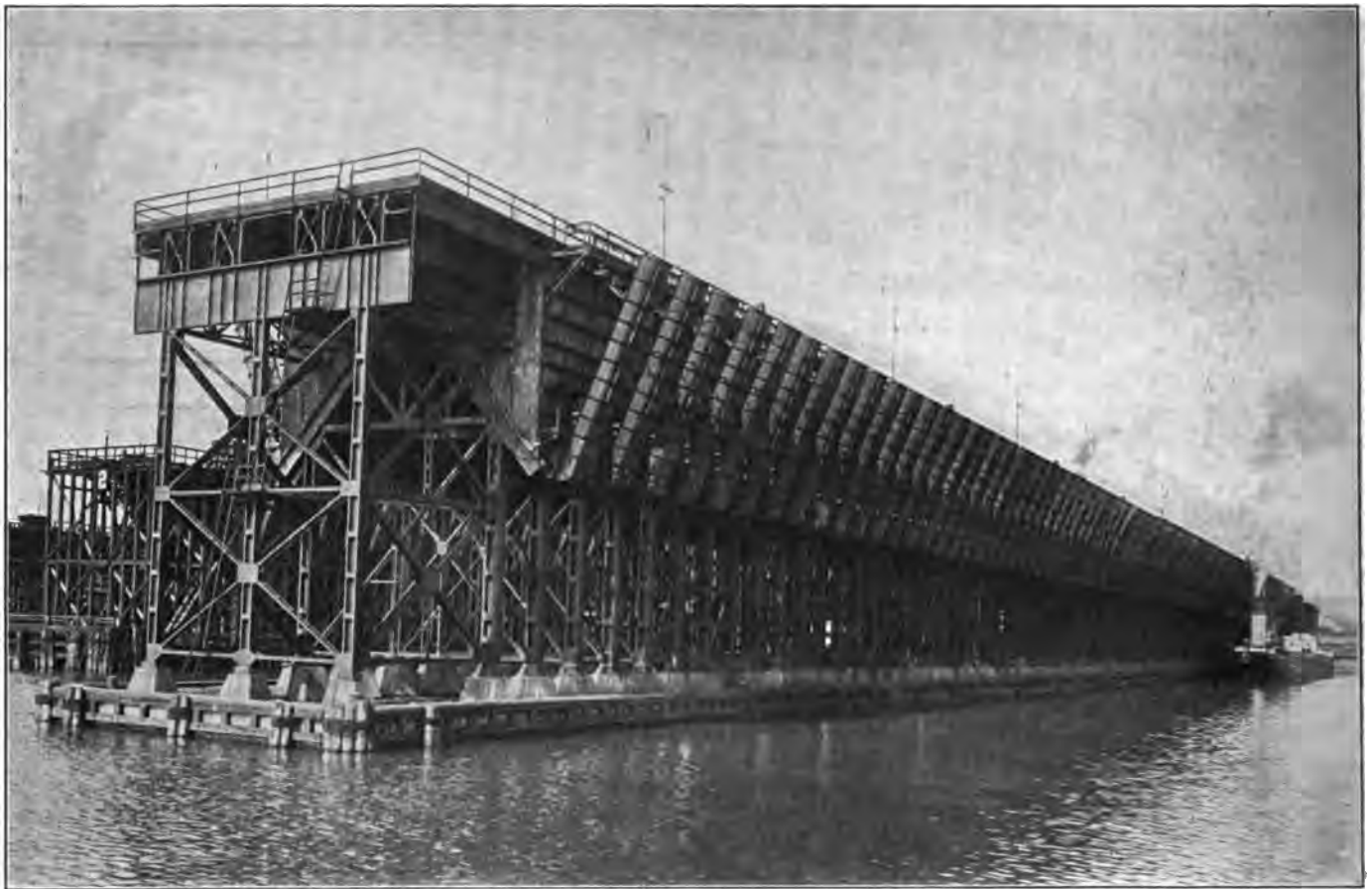

Fig. 4—New Duluth and Iron Range Steel Ore Dock at Two Harbors, Minn.

five, although in some cases 10 cars are handled, depending upon the grades of the approach track. In general it is not considered economical to operate pusher engines in the mines and the pit locomotives are given only the number of cars which they can handle from a shovel to the yard. The number of trains operated in the mine is usually about twice the number of steam shovels working, this ratio varying with the distance between the mine and the yard. These trains are operated under the direction of a pit boss, who usually has a shanty beside the approach track in a position commanding a general view of the mine so that in case of delay at one shovel he can divert the trains of empties to other shovels.

A yardmaster in charge of each yard is responsible for the distribution of empty cars to the mines under his jurisdiction. Telephonic communication is maintained between the offices of the yardmaster and the pit boss so that the former may be informed immediately of any delays to shovels that will influence the dis-

tribute train in one mine yard and take it direct to Proctor, a large yard about seven miles from the docks. This line has a maximum grade of 0.3 per cent. against traffic, and two per cent. against empties between Duluth and Proctor, and 0.8 per cent. north of Proctor. Because of this condition, the "hill," as the section between Proctor and the docks is called, is operated as a separate division. The average tonnage per train north of Proctor is about 2,800 net tons, or a gross tonnage of 3,696 tons. It is difficult, however, to load the trains at the mines with very great accuracy because the ore itself varies in weight according to the quality, and the cars are not weighed until they reach Proctor.

Arriving at Proctor these trains are broken up in accordance with instructions received by wire from the mines, based on an analysis of the ore and are made up into trains for movement upon the docks. The tonnage of trains on the "hill" varies in accordance with the amount of ore that is ready to go to the

docks or that is required by the docks, but is always at least equal to the tonnage handled north of Proctor. The run from Proctor to the docks is made in about 45 min., each engine making five round trips in from 10.5 to 12 hours. Mallet locomotives are used for this service, and have proven very economical, as the service requires the development of the full power of the locomotives through the entire run.

About 27 trains of ore were handled daily by the Missabe Railroad in the season of 1910, the gross ore tonnage of 1910 amounting to 13,609,017 tons, and creating a freight traffic dens-

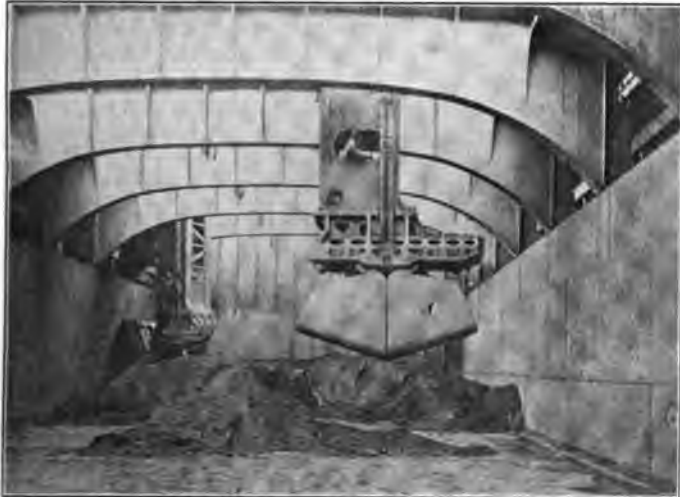

Fig. 5—Interior of Modern Ore Boat, Showing Freedom of Obstructions.

ity in excess of 3,500,000 ton miles per mile of line, in spite of the fact that the northbound movement consists very largely of empty cars returning to the mines, and that the traffic is nearly all handled during the seven months of open season of navigation.

On the Duluth & Iron Range practically the same method of operation is followed except that trains are handled directly from the originating yards to the distributing yards at the docks at Two Harbors. As this line traverses a more hilly country than the Missabe road, its train loading is not as heavy although it has recently added six Mikado locomotives equipped with

superheaters for this service. This road hauled 9,349,000 tons of ore in 1912.

THE UPPER LAKE DOCKS.

Arriving at the lake, the cars are run onto the dock and unloaded by gravity into storage bins, the different grades of ore being unloaded into separate pockets. The mixing of the ore to meet the mill requirements as to grade, as outlined in the season's schedule, is done by unloading required amounts of the different grades into the ore pockets, the actual mixing being secured in the further handling before the material reaches the mills. For the purpose of facilitating transportation, the 200 grades were here combined into 20 groups.

These docks are owned and operated by the railways delivering ore to them. Within the past few years the type and size of dock have materially changed. Three examples of recent steel and concrete structures, including the Duluth & Iron Range dock at Two Harbors, have been described in the *Railway Age Gazette* within the past few months. All of these docks have made excellent records, it being reported that the cost of operation of one of them was less than one-third the cost of an old wooden dock previously used. Special features in the design of these docks are the self-cleaning of the bins, the adoption of electric hoists for handling the spouts, and the arrangement of the spouts whereby the ore may be distributed in the boat so as to require the minimum of trimming and the practical elimination of all hand labor in transferring the ore from the cars through the dock to the vessel. These docks contain from 110 to 200 pockets on each side, each pocket containing 150 to 300 tons of ore. From four to six boats can be loaded at one time. As an example of the amount of ore which can be loaded into a vessel, 9,500 tons of ore were loaded into one vessel in 25 min. shortly after the completion of the Great Northern dock, and at another time eight vessels with an aggregate tonnage of 62,000 tons, were loaded in six hours, an average rate of 10,333 tons per hour.

THE STEAMSHIP LINE.

The Pittsburgh Steamship Company operates between the Lake Superior docks and Lake Erie and South Chicago ports with 79 steamers and 21 barges in this service, the newer vessels being of all-steel construction, 600 ft. long by 58 ft. wide, and free of interior obstructions, as shown in one of the photographs. These boats will carry 11,000 tons of ore with a 19 ft. stage of water at the Soo Canal, this being the critical point. The distance from Duluth to South Chicago is 817 miles and to Cleveland 834 miles,

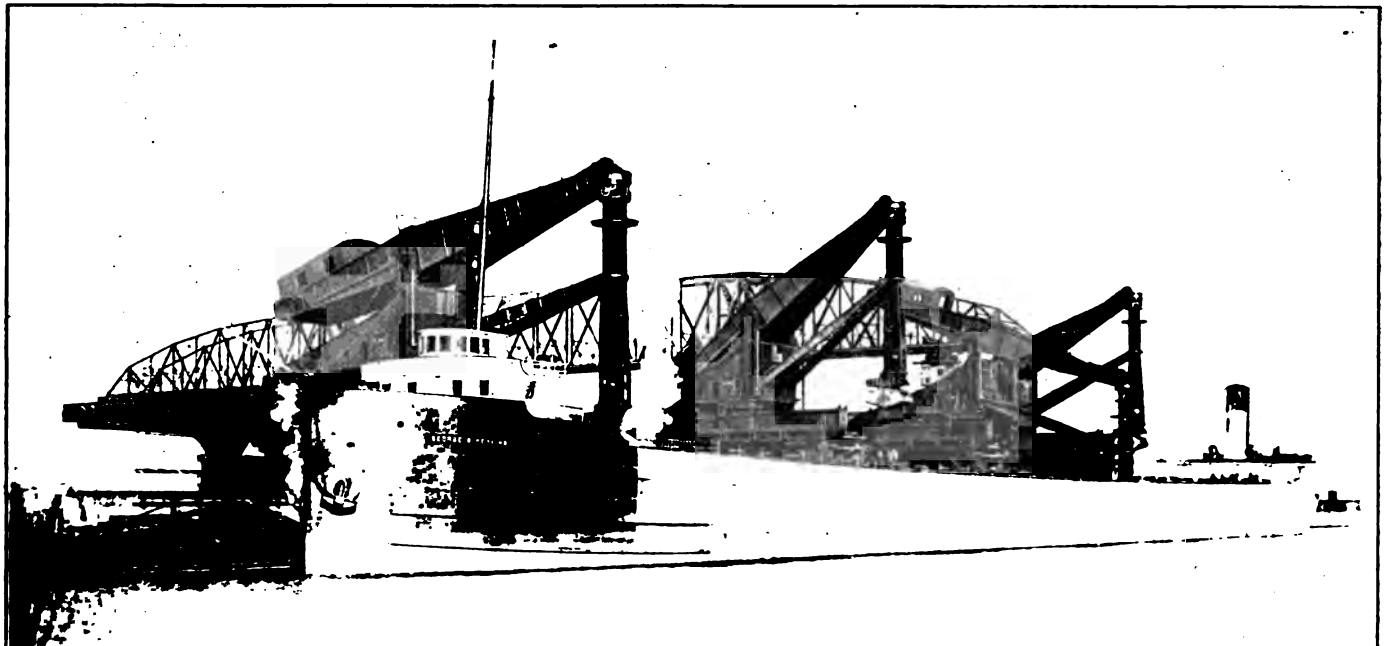

Fig. 6—Hulett Unloaders with 15 ton Buckets at Work on Comeaut Dock.

requiring about  $3\frac{1}{2}$  days each way. The average detention at the head of the lakes for loading and other delays is 15 hours, and for unloading at the lower lake ports is 27 hours. The average season of navigation is about 200 days. Last year the fleet made 21 round trips.

These boats carry only Corporation ore southbound and are then able to move only about 60 per cent. of the tonnage, the balance being handled in vessels chartered by the season or trip. About 14,600,000 tons of ore were moved by boats of the Pittsburgh Steamship Company last year, and about 1,200,000 tons of coal, largely for company use, was handled northbound. No attempt is made to secure traffic northbound, as the first aim is to maintain a regular service for the Corporation. However, whenever there is a shortage of other boats for northbound movement, as frequently happens at the beginning and end of the season, these boats are loaded northbound at the solicitation of the shippers. This northbound coal movement on the lakes is increasing rapidly. In 1902 27,039,000 tons of ore moved over the lakes, while in 1912 this had risen to 47,435,000 tons, while the coal business increased from 8,359,000 tons in 1902 to 23,335,000 tons

at the ends of their trips, and are also supplied by a commissary boat which moves through the locks at the Soo with them in order to save delays. In addition to the ore service, boats are maintained in regular service hauling limestone from Calcite, Mich., to South Chicago and Gary, about 200,000 tons being hauled last year.

#### THE CONNEAUT DOCK.

Of the 37,465,853 tons of ore unloaded at Lake Erie ports last year, 7,839,831 tons were handled at Conneaut. This was brought in in 1,009 vessels, 492 of which belonged to the Pittsburgh Steamship Company, and 517 to independent owners, the average cargo of 7,770 tons being 10 per cent. under the average loading because of low water at the Soo. The increase in the amount of ore handled at this port, as well as in the capacity of the vessels, is strikingly shown by the fact that in 1893, the first year when these docks were operated to any extent, 100 vessels brought 203,207 tons of ore.

About 20 per cent. of the ore received here is stored for movement to Pittsburgh during the winter, while the remainder



Fig. 7—Typical Ore Train of the Bessemer Road Leaving Conneaut Harbor.

in 1912. As the above figures show, the coal business is handled almost entirely by private boats.

The number of boats on the lakes has usually been in excess of the demand. For this reason the rate net to the boats on ore from upper to lower lake ports has gradually decreased from \$0.61 in 1901 to \$0.40 in 1912, although because of the prospect of large shipments this season the rate returned this spring to \$0.45. This rate fluctuates with the condition of the ore business, and the supply of boats and is fixed by season charters.

The boats of the Steel Corporation are not placed in service between certain definite ports, but are moved from port to port as conditions demand. All boats loaded for Lake Michigan ports are despatched to South Chicago, and may then be ordered to Gary if the ore is desired at that point. Boats loaded for Lake Erie ports are despatched to Cleveland and receive definite instructions regarding destination at Detroit. All despatching of boats is handled from Cleveland, this despatching being determined by the original schedule of ore movements, the quality of ore in the cargo, the car supply at the docks, the supply of ore at the furnace, etc. The boats are loaded and unloaded in turn at the various docks. They are given the necessary supplies at

is unloaded from the boats directly onto cars. The ore is unloaded by machines, mainly of the Hulett and Brown types, there being nine new machines and 25 old ones on this dock. The new machines will handle from 10 to 15 tons at each operation. In placing cars under the unloaders a plan first adopted at Conneaut, and since installed at a number of other docks, was the construction of a loop back of the machines on which cars were placed by a switch engine. From this point the cars are drawn under the unloader by cables, in this way giving a continuous movement and eliminating the delays to the machines which would otherwise be necessary while switching cars.

Of special interest to the railway man is the fact that the cars leave the dock with an average of 97 per cent. of their maximum load, including 10 per cent. overload. The new 15-ton Hulett Electric unloading machine is equipped with a weighing device.

On other machines an estimator is located at each machine who gages the amount loaded on each car. After leaving the machines these cars pass over the scales and if not properly loaded, to a trimming machine, which either adds or removes ore sufficient to bring the car within the limits of loading, in this way securing the maximum service out of the cars. The only

8.5  
280000

classification of cars before loading is to separate the hopper bottom cars from the gondolas to facilitate unloading at the mills.

As an indication of the amount of ore which may be handled, on August 12, 1912, the nine new machines unloaded 10,636 tons of ore from one boat between 2:20 and 5:10 p. m., which after deducting delays, was at the rate of 4,137 tons per hour. On May 20, 1912, 1,186 cars, or 55,230 tons were loaded from the dock and vessel, while on August 19, 1911, 1,202 cars, or 55,432 tons, were loaded in 20 hours. At another time these machines unloaded 101,054 tons, of ore from 10 boats in 42 hours and 45 minutes, or an average of 2,364 tons per hour. A boat ordinarily contains but one quality of ore, although under certain conditions two or three grades may be loaded in one cargo.

With the exception of that destined to Clairton and McKeesport, all ore is billed simply to North Bessemer and is distributed from there on orders from the general offices. A card showing the number of the car, the name of the vessel, the date loaded and the grade of the ore, is placed on each car as it is loaded and a duplicate slip is given the weighmaster. A car cannot be moved unless it is carded, and the conductors are required to check their waybills with these cards before starting their trains. As a train of ore leaves Albion the offices of the Steel Corporation in Pittsburgh are advised by wire of the movement of the cars and of the kind of ore on them.

In addition to the ore this dock loads a large amount of coal, rails, brick, cement and miscellaneous material northbound on Corporation and outside boats. One collier is in regular service across Lake Erie to Rondeau, Ont., making a regular trip every two and one-half days, while a car ferry with a capacity of 30 cars operates to Port Stanley, Ont., twice daily. The collier is provided with tracks on its deck, is loaded from drop bottom cars and carries a cargo of 2,500 tons of coal in the hold. In case coal for collier shipment is received in gondola cars the transfer from the cars to the collier is made by means of a car dumper, the "kickup" at this dumper operating with the loads rather than with the empties as is the usual practice. A new modern car dumper will be installed this year, increasing the capacity at the dock for coal shipments up the lakes and reducing vessel delays on lake shipments. Ten engines and 24 crews are required on the dock and in the assembling yard.

THE BESSEMER & LAKE ERIE.

The most interesting portion of this entire system from the transportation standpoint is the Bessemer & Lake Erie Railroad. Built originally between Conneaut Harbor, Ohio, and Butler, Pa., a controlling interest in it was obtained by the Carnegie Steel Company in 1896, and the line was extended 42 miles, from Butler to Bessemer, giving it access to the Carnegie Steel Company works at Braddock, Homestead and Duquesne through the Union Railroad. The through line was opened for business in the fall of 1897. The total tonnage handled by it in 1897 was 1,151,356 tons, of which 500,328 tons was ore, and 650,928 tons other freight. This road now carries more than that tonnage monthly during the navigation season. The distance from Conneaut Harbor, O., to North Bessemer, Pa., is 142 miles. Topographically it has the least favorable location of any of the large ore carrying roads between Lake Erie and Pittsburgh, crossing eight water sheds.

It is operated from the dock to Albion, a distance of 16 miles, with heavy drag engines of the consolidation type weighing 391,000 lbs., with 225,000 lbs., on the drivers, hauling 2,550 tons up the 1.1 per cent. grade with the assistance of a pusher engine for the first two and one-half miles. From Albion to North Bessemer, 126 miles, trains of 2,100 tons are hauled by consolidation engines weighing 336,000 lbs. with 180,000 lbs. on the drivers. The ruling grade southbound is 0.6 per cent. and northbound 0.75 per cent. A pusher engine assists southbound trains over a district of seven miles from Conneautville south, and trains are double-headed for 90 miles into North Bessemer in order to provide power for northbound movements. This arrangement also permits southbound tonnage trains to pick up six cars of

limestone each in the vicinity of Butler for the mills, 100 cars of this material being moved in this way daily without any increase in train mileage.

A study of the Bessemer is very interesting from the traffic standpoint. The main traffic is, of course, ore southbound, while coal, finished steel products and miscellaneous traffic are moved northbound. The ore traffic has increased from 3,662,417 tons in 1901 to 8,578,930 in 1912. In the same period coal traffic northbound has been developed from in the neighborhood of 1,000,000 tons to 3,782,621 tons, and miscellaneous traffic from 1,761,781 to 3,017,871 tons, the coal moving mainly up the lakes and across Lake Erie to Canada by ferry and collier, while finished steel and miscellaneous products are turned over to the Erie, Lake Shore, Nickel Plate and Buffalo, Rochester & Pittsburgh roads for various destinations. Thus, while the ore traffic southbound has increased 135 per cent. in 11 years, the percentage of all traffic moving northbound has risen from 25.2 per cent. to 34.8 per cent. This northbound traffic has practically all been developed by the road, and with the further development of coal properties now under way it is expected that the northbound traffic will equal, if not exceed, the southbound traffic within two or three years. It is also interesting to note that the traffic density in ton miles per mile of line has increased from 3,375,719 in 1901 to 8,940,080 in

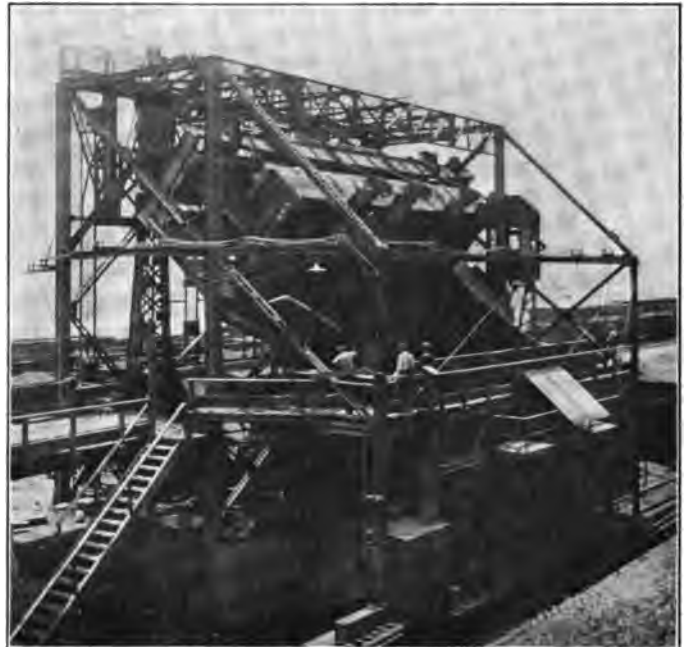

Fig. 8—Car Dumper Unloading a Gondola Car at the Mill.

1912, this latter figure being exceeded by only one road in this country, the Pittsburgh & Lake Erie. This latter road has four tracks over a large portion of its lines, while the Bessemer has only two tracks, with three stretches of single track amounting in all to 11.5 miles. In connection with this unusually high freight density the passenger train revenue per mile of line for 1912 was \$2,028.68, all of which is derived from distinctly local traffic.

Although the rate for the transportation of ore is the same from all lake ports to Pittsburgh, the operating ratio of the Bessemer for last year was 54.92, which is again unusual, and is the result of several conditions. In the first place, the average number of revenue tons per train for 1912 was 1,038 and per loaded car, 43.53, while improvements now under way near the southern end of this line will materially raise the train tonnage. At the present time the Bessemer is required to dispose of 125 cars of waste material from the mills daily, in winter as well as in summer. This material is being utilized to remove sags at a comparatively small expenditure, and upon the completion of this work the mileage of assistant engines will be materially reduced.

Another point in which this road stands out conspicuously is

in the absolute uniformity in the movement of the trains over the lines from Albion to North Bessemer. During the season of navigation ore trains leave Albion every hour and move over the 126 miles to North Bessemer in an average time of 12 hours and 20 minutes, this monthly average not varying over five minutes from month to month throughout the year. As a result, trains are never tied up under the 16-hour law, and there is practically no overtime for train crews. This condition is brought about by several causes. In the first place, the engines are not overloaded, but are given such tonnage as they can move over the line readily. In the second place, there is no terminal delay, engines and cars being placed in the trains and the waybills checked with the train before the crew takes charge. The trains are thus enabled to leave the terminal at the time for which the crews are called, the average delay being less than seven minutes per train. This in itself assists in preventing the application of the 16-hour law, for the entire time of the crew is spent on the road. Also, three dispatchers' districts are provided for the 225 miles of line, all of which is equipped with telephone and manual block. The dispatchers are thus enabled to keep ahead of their work all the time and train movements are anticipated. Another cause contributing to this result is the staff of trainmasters. Two general trainmasters are provided in charge of the office and outside work, respectively. In addition to this, two assistant trainmasters, each in charge of a certain portion of the line, and two road foremen of engines spend practically their entire time riding trains and supervising their movement.

#### THE UNION RAILROAD.

At North Bessemer the traffic for the furnaces and steel mills of the Corporation is turned over to the Union Railroad for delivery to the mills and industries or to connecting lines. The mills are advised daily of the shipment of Corporation ore from Conneaut, and of its receipt at North Bessemer, and they in turn advise the superintendent of the Union Railroad each morning and evening of the amount of ore of the different qualities which they will require for the following 12 hours for mill consumption and for winter storage, for the mills endeavor to accumulate as large storage piles as space will permit during the summer to avoid shipping frozen ore during the winter. Acting upon these advices, the specified amounts of ore of the different grades are distributed to the various mills by the Union Railroad, the ore being delivered by grade only, as shown by the cards on the cars, these cards following the ore into the mill even if it is transferred from one car to another en route. In this way switching is reduced to a minimum, while the mills get the ore they desire.

Arriving at the mills the cars are in general emptied by car dumpers and the ore is transferred either onto stock piles or into bunkers for charging the furnaces. At one of the older mills, however, these bunkers are filled from a trestle from hopper bottom cars, although it occasionally becomes necessary to run gondolas over the bunkers and unload them by a clam shell or by hand if no hopper cars with the proper grade of ore can be secured. This, however, is the exception, and occurs at only the one mill.

The yards at each mill are under the direct charge of a general superintendent of transportation, who has supervision over the movement of cars after delivery to the mill by the Union Railroad. As an example of the amount of traffic handled, an average day's receipts at the Edgar Thomson mill is 16,000 tons of ore, 2,400 tons of limestone and 4,800 tons of coke. During May of this year, 38,000 cars were moved in and out of this mill, while 50,000 cars are handled monthly at the Homestead works. The Homestead plant contains about 200 miles of track and requires 33 switch engines for its operation. About 200 cars of finished material are shipped out of this plant daily, practically all of which is loaded in gondolas which have brought ore inbound.

The various units in the general transportation system are each under the direct charge of a local officer as president or vice-

president, who devotes his entire time to the one unit. General supervision of the entire system is concentrated under the direction of D. G. Kerr, vice-president of the United States Steel Corporation, who directs the operation of the various units to insure their full co-operation, as outlined above.

## THE RAILWAY BUSINESS ASSOCIATION ON RAILWAY INCOMES.

The Railway Business Association has issued bulletin No. 14, which is divided into two parts, one entitled "Railway Income Still Under 1910," and the other entitled "Making Equipment Carry All It Can." The second part contains a large amount of information regarding the car situation and means by which the efficiency of the use of cars can be increased. Among other matters there is a short statement by Chairman Clark of the Interstate Commerce Commission, resolutions adopted by the National Industrial Traffic League, urging shippers and railways to co-operate to increase the movement of cars, and a short article by President Kruttschnitt of the American Railway Association along the same general lines. The discussion regarding railway income is as follows:

"Current monthly reports of railway revenue and expenses, if studied in the light of the 1910 experience, will afford business bodies important guidance in adopting an attitude toward the proposed advances in eastern freight rates.

"The Interstate Commerce Commission two years ago expressed the hope that the roads would increase their income without any advance in rates, and accordingly denied the advance. Since then complete statistics have been published for 1910, 1911 and 1912.

"Operating revenue was 1.4 per cent. larger in 1911 than in 1910, and 2 per cent. larger in 1912 than in 1911, yet net corporate income, available for improvements, dividends and surplus, was under the 1910 record by 20 per cent. in 1911 and under the 1910 record by 15 per cent. in 1912.

"This decline in net corporate income despite higher operating revenues was due to the rise in costs: (1) rail operating expenses, (2) taxes and (3) the debit which arises from balancing non-operating receipts against non-operating expenses, chiefly interest.

"Weakened selling power of railway securities as compared with corporations which can raise their prices and hence can offer a higher return on new issues has put beyond doubt the insufficiency of railway income in past years. A previous bulletin demonstrated that new capital issues of steam railways listed on the New York Stock Exchange were in 1912 the smallest in ten years, while new issues listed by non-railroad corporations were the largest of the decade. Those who think that the trouble is over-capitalization should read an article on that subject in the *Saturday Evening Post* for August 9, 1913, by Alba B. Johnson, in which it is demonstrated that American railways are capitalized so low compared with foreign lines as to raise the question whether any difference in conditions could offset the discrepancy in our favor. The practical condition of declining railway credit is not disputed.

"Nor should superficial impressions derived from preliminary monthly reports give the public a false confidence in better results for the future on the present level of freight rates. Some business men have asked whether the earnings of 1913 do not meet the situation and render an advance in rates unnecessary. For their benefit and that of others who may share that impression it seems desirable to demonstrate in detail that the preliminary figures now available contain no basis for any prediction whatever.

"For eleven months of 1913 bulletins of the Bureau of Railway Economics are out, compiled from the commission's returns. An inexperienced observer jumping at conclusions may find, or think he has found, that operating income (operating revenue

less operating expenses less taxes), amounting to \$3,396 per mile of line, is substantially greater than one or another figure for eleven months of some previous year. From this he might confidently predict that as a result of the operations of 1913 the railway system has realized the increased 'income' prophesied two years ago.

"As a matter of fact these preliminary returns will not bear any such interpretation; for operating income has still to be scaled down by large deductions not yet reported, and estimates computed upon actual deductions used in obtaining final figures in previous years tend to show that net corporate income in 1913 did not rise to the level of 1910.

"Disclaiming prophetic gift and going through some imaginary computations merely to show the unsafeness of current monthly reports as a basis for forecasts, let us endeavor to chart the route which anyone attempting such predictions would have to travel before he could offer reasonable ground even for a guess as to future railway income or even income for the fiscal year just closed.

"Our prophet starts out with an operating income of \$3,396 per mile for eleven months for the roads included. Here are some deductions to which his figure is subject:

"(1) The roads included in that report are those having a million dollars or more operating revenue. These are the more prosperous roads. When the poorer lines are averaged in for the ultimate statistics of the commission, this amount per mile of line is pulled down. For instance, the Bureau of Railway Economics in May, 1911, reported for the large roads operating income per mile of line as \$3,058 for eleven months. The ultimate figure for all roads proved to be \$163 less, or a shrinkage of 5.3 per cent. There is nothing to assure us that the shrinkage will be smaller in the year 1913 than it was in the year 1911.

"Suppose shrinkage in operating income from preliminary to final figures shall be at the same rate as in 1911, or 5.3 per cent.; our \$3,396 would become \$3,216.

"(2) Nobody knows how many miles of line will be included in the ultimate statistics for 1913. The average annual increase in mileage operated from 1908 to 1912 was 2.09 per cent. If this happened to be the precise rate of increase in 1913 the mileage operated would be 255,611.13. If the mileage omitted from the income account should be in the same proportion to the total mileage operated as in 1910, or 1.6 per cent., the mileage to be considered would be 251,521.36. Operating income at \$3,216 per mile would be \$808,892,693.76, or an increase over 11 months of 1910 of 5.5 per cent.

"(3) We next proceed to estimate sums deducted from revenue after payment of operating expenses and taxes.

"The biggest item in such deductions is interest on funded debt. The 1913 plant is not the same plant as that of 1910. New investment has been made in it. Nobody knows how many miles of track there are. If they increased in 1912 and in 1913 at exactly the same rate as in 1911, or 3.1 per cent., there were 33,901 more miles of track in 1913 than in 1910, or an increase of 9.6 per cent. Aggregate tractive power of locomotives in 1913 may not be published for a year or two yet. One man's guess is as good as another's. But if it rose in 1912 and 1913 at just the annual rate of 1911, or 5.8 per cent., then drawing power of locomotives was 293,311,501 lbs. greater in 1913 than in 1910, or 18.5 per cent. All we have concerning enlargement of freight car capacity since 1911 is the unofficial information that the calendar year 1912 saw a larger number of freight cars built than the twelve-month preceding. Suppose this form of additions rose in 1912 and 1913 at the identical rate of 1911, or 5.8 per cent.; then in 1913 there were 14,175,970 more tons of freight car capacity than in 1910, or 18.5 per cent.

"This investment in track and rolling stock, to say nothing of steel passenger cars substituted for wooden, safety devices installed, grade crossings eliminated, roadbed and bridges rebuilt, grades and curves corrected, terminals improved and extended,

have created new charges against income, a large part being obligatory interest on funded debt.

"How much is the increase in fixed charges? It will take two years or so to find out.

"To ascertain at that distant date net corporate income available for improvements, dividends and surplus, we shall have to deduct from operating income the difference between non-operating income and non-operating expenses—always a debit. If such deductions progressed in 1912 and in 1913 at the average annual rate in 1909, 1910 and 1911, or an increase of 6.93 per cent., they reached in eleven months of 1913, \$347,036,845. This conjectural net deduction from our estimated operating income, \$808,892,693.76, would leave \$461,855,848.76 as the net corporate income available for improvements, dividends and surplus. That item in 1910 for eleven months was \$473,545,160.

"Our prophesied increase of income, if past averages hold good, has shrunk in 1913 to a loss under 1910 of \$11,689,312, or 2.47 per cent., and this with a plant in 1913 estimated to have 33,901 more miles of track than the plant of 1910, 293,311,501 more pounds of locomotive tractive power and 14,175,970 more tons of freight car capacity, and to have carried 7,900 million more tons of freight one mile.

"We have endeavored to lead over his course in imagination the prophet who bases predictions of increased income upon current reports of operating revenue, operating expenses and taxes. Without traversing the course in reality the facts cannot be ascertained as to the ultimate result of railway operations for the fiscal year 1913. The conjectural estimates indulged in have an infinitely sounder basis in past experience than to repeat in 1913 for the year 1914 and following those forecasts made in 1910 which grim facts have since so completely disappointed.

"Prominent business organizations in St. Louis, Cincinnati, Pittsburgh, Philadelphia, Baltimore and other large cities have adopted resolutions favoring, or deciding not to oppose, higher freight rates where under the eastern roads may provide better service. Other bodies have the matter under consideration. It is of national importance that shippers and trade associations avoid preliminary returns as a clue to the complete income account and avoid estimating future income on the basis of earnings in the single year in which the rate case is heard. The resources of a railway during a period of years are the sum of poor years and good alike, not the product of the best year multiplied by the number of years. Action should be based upon the known past, not upon the half revealed present.

"The veteran merchant, E. C. Simmons, said in an article in *Leslie's Weekly* for June 5: 'Thousands of shippers all over the land have come to realize the fact that their business is prosperous only when the railroads are prosperous and that any slight increase in freight rates which they might have to pay would soon be lost sight of in the enormous increase in the profits of their business which this general prosperity would bring about.'

"Hardly any national calamity could be more exasperating than industrial prostration descending in the midst of busy times, with order books full and mills running to capacity—prostration brought about by congestion of terminals, throwing into idleness, with their employees, factories which could neither obtain raw material nor deliver finished product, while food stuffs lay rotting in cars and elevators.

"The public had better be safe than sorry—assured of good service rather than in danger of a transportation breakdown."

RAILWAYS IN GERMAN EAST AFRICA.—The German Colonial Office is at present negotiating with a group of banks in the capital for a loan of about \$12,500,000, which is required for the further construction of the Central Railway across German East Africa to Lake Tanganyika and to finance a land mortgage bank in South-West Africa.



## REPORT ON TYRONE COLLISION.

The Interstate Commerce Commission issued, September 9, a report, dated August 19, and signed by H. W. Belnap, chief inspector of safety appliances, on the rear collision of passenger trains which occurred at Tyrone, Pa., on the middle division of the Pennsylvania Railroad July 30 last.

This accident was reported in the *Railway Age Gazette* of



Fig. 1—Dining Car and Coach, Second and Third from Rear of No. 15.

August 22, page 329. The government report gives some additional details concerning the cause. The leading train had been standing at the station about five minutes. The rear brakeman, after assisting passengers to get off and on, started back with his red flag, but he had only gone 500 ft. when he was called in. He had not gone beyond the end of the station platform, and so did not put down torpedoes, as the use of torpedoes opposite a station platform is forbidden. The following train, No. 13, passed distant and home automatic block signals



Fig. 2—Dining Car and Parlor Car (Parlor Car Last in Train).

set against it; and the inspector believes that probably a clear distant signal for track No. 4, on the same bridge, was mistaken for the signal for track No. 3, on which the train was running. An assistant road foreman of engines was on the engine and he and the fireman are censured also. (The engineman was killed.) The foreman is censured for calling out the signal, when he approached it, instead of leaving the engineman and fireman to perform their functions themselves, his duty being not to aid them, but to see that they themselves performed their duties properly. When they came to the home signal all of the three men recognized that it was against them; the foreman was the first to see it and he shouted to the engineman; and the inspector believes that if the emergency brakes had been applied at that moment the collision would have been averted or greatly mitigated.

The shock of the collision was largely absorbed by the crushing of the platforms and vestibules of the cars, all the cars in the leading train being of steel. The rear car, however, was partly crushed. The engineman was the only person killed. The



Fig. 3—Engine and Parlor Car.

inspector says that the flagman should not assist in loading and unloading passengers, but he is not censured, the rule requiring that a flagman go back immediately applying only at places other than stations. Had the rules required the flagman to be stationed at the rear end of the train, and at regular stops of more than one minute duration to go back, he could in this case have gone back beyond the home signal; and if he had done so and had put down torpedoes, it is the opinion of the inspector that the collision would have been averted.

Three illustrations, accompanying the report, and showing the effect of the collision on some of the steel cars, are reproduced herewith.

LABORATORY OF THE SOUTH MANCHURIA RAILWAY.—The South Manchuria Railway plans to expend the following in its experimental enterprises operated in connection with the central laboratory of the railway: Construction and equipment of building for weaving pongee silk, and brewing and distilling liquors from local products, \$60,000; pottery enlargement, \$10,000; new experimental bean-oil mill, \$115,000; enlarging main laboratory, \$100,000. To these expenditures the cost of machinery to be installed by the South Manchuria Railway, will bring the total to about \$400,000. Some of this construction work will be begun during the year 1913, and the remainder next spring.

# MASTER PAINTERS' ASSOCIATION.

## Important Reports on Finishing Steel Passenger Train Cars, Paint Protection for Steel Equipment and Paint Tests.

The forty-fourth annual convention of the Master Car and Locomotive Painters' Association was held in Ottawa, Canada, September 9 to 12, as noted in the *Railway Age Gazette* of September 12, on page 472. The following is a report of the convention:

### PRESIDENT'S ADDRESS.

President A. J. Bush in his address spoke of the successful work of the various committees, especially that of the information and test committee. Both these committees have given the association some very valuable information, and it is hoped that more of the members will make greater use of the information committee. He exhorted the members to participate freely in the discussion and to do everything in their power to make the work of the association a material success.

### FINISHING STEEL PASSENGER CARS.

Two papers were presented on this subject, one by John Gearhart (Penna.), and another by H. M. Butts (N. Y. C.). Mr. Gearhart described the baking process by means of a large oven which the Pennsylvania have placed in service at Altoona, Pa. This oven is large enough to accommodate the largest car on that road, being 90 ft. 3 in. long, 13 ft. wide and 15 ft. high. This oven is heated by steam coils, having a total surface of 2,741 sq. ft.; the ratio of heating surface to cubical contents being one to six. This oven has been heated to as high as 305 deg. It is believed that the temperature can be raised to the desired degree in from 2½ or 2 hours without affecting the durability of the paint. With this oven it is possible to paint two cars complete in 6½ days, the saving in time on new cars being between 7 and 10 days over that of the air-drying system. The advantages of the baking process are that the cars may be finished on schedule time, the temperature and weather conditions can be more carefully regulated and there is no interference by workmen of the other trades while the paint is drying. Two 54-ft. passenger cars, four 78-ft. dining cars, six 70-ft. baggage and mail cars, four passenger locomotive tenders, and 20 steel hopper cars have been baked in the oven at Altoona, and 1,000 steel freight cars are to be baked at the oven at South Amboy, N. J., next month. Experiments are being made with non- and semi-drying oils on freight cars. Japans or other artificial driers are not used in this baking process.

H. M. Butts (N. Y. C.): The baking process is attracting more attention at present than any other. The baking of paint and varnish mixtures is not new, but has long been in common use. However, as applied to passenger cars, it is comparatively new, and largely in the experimental stage. The various formulas are very imperfect and cannot be relied on as giving the proper proportion of material which can be safely used in mixing the various colors for the baking process. One eminent authority, J. W. Lawler, chief chemist of the Pullman Company, says that results and experience based on practical tests show that the life of a baked paint on steel is greatly prolonged, its adherent qualities are increased and it has the additional value of being much more impervious to moisture and gas than the same vehicle unbaked.

Allowing this statement to be correct, has it been fully determined whether its life has been really and wonderfully improved? From time immemorial it has been a commonly accepted fact that slow-drying and more elastic vehicles will resist moisture and severe atmospheric changes for a much longer time than a quick, hard drying one, also that very soon after a vehicle loses its elasticity, decomposition sets in and complete disintegration is very near at hand. Immediately after baking, a vehicle becomes hard and brittle, which justifies the assumption, does not baking hasten its destruction? A sufficient ex-

posure or service test can only satisfactorily answer this question. Whether the baking of paint on passenger cars will ever become an economical proposition is very much in doubt, as the mechanical difficulties of baking an entire car are very great. The time required for cooling off the hot metal before a subsequent coat can be applied with safety is something that must be considered.

Baking the interior separate from the outside is being tried with considerable success by the Hudson & Manhattan of New York City. Electric heaters are suspended from the ceiling which furnish the heat, the windows and doors being closed tight, thus enabling a proper amount of heat to be generated to accomplish the baking.

The prevention of corrosion of the metal seems to be the most difficult problem which confronts us. Numerous mixtures claiming to prevent corrosion are on the market. There is no reliable evidence at hand which proves that any of them can be safely used for painting passenger cars. Most of the so-called rust preventatives are only suitable for use on structural steel, such as is used on bridges and buildings.

The New York Central has not made any very radical changes in the paint specifications; with the one exception, that of using the same priming coat for both wood and metal. We have in service about 200 steel passenger cars which were painted about 7 years ago with one of the surfacing systems, well known to us all, which are making a very excellent showing. The surface of these cars was first thoroughly sandblasted, then primed and surfaced in the good old-fashioned way.

### DISCUSSION.

H. M. Butts (N. Y. C.): If a paint can be dried artificially without the use of a liquid drier its life and durability will be increased and this feature alone would make the baking process worth while.

John Gearhart (Penna.): The surfacers used have been prepared in our own laboratories. We have been experimenting with six or eight different varnishes. Some we find will bake better than others; some became flat after rubbing, while others looked the same as if they were air-dried. The cars baked last February are in much better condition at the present time than those that were air dried. Baked dining cars running in the tunnels at Washington, D. C., appear to be in the same condition after the eighth cleaning as the air-dried cars after their fifth cleaning. The air-dried finish on the car does not behave like those on the test panels, the test panels being much shorter lived than the cars. The baking process is practical and looks economical, but it will be a year or so before definite information can be obtained.

J. H. Pitard (M. & O.): Our traveling inspector found a loaded steel freight car broken in the middle, due to rust. While this is an exceptional case, it shows what rust will do if a steel car is neglected.

### TEST COMMITTEE'S REPORT.

Oscar P. Wilkins (N. & W.), chairman of the test committee, read the following report:

In order to determine the actual relative value of paint stock it is necessary to make service tests under normal conditions, but as it requires long periods of time to accomplish satisfactory results, we find in the test panels a good medium for making comparative tests. Accelerated tests under abnormally severe conditions are misleading unless the results obtained by the method selected will be in harmony with long time service tests. Therefore in making a panel test we should adhere closely to the line of actual practice in preparing the panel, and the exposure should be consistent with that of actual service.

The test panels of varnish exposed for 12 months beginning July, 1912, and which were referred to in the last year's report, were prepared in accordance with these views. We consider the test an accelerated one, but one that indicates the comparative value of the varnish samples involved. The samples were secured from various master painters who are members of this association, and were taken from the regular purchased stock. The wood panels, 14 in number, and 5 ft. long, were cut from the same piece. They were finished with the same priming, surfacing and coloring materials in exactly the same manner as a new wooden passenger coach. Three coats of varnish were applied to each panel, 48 hours being allowed between the coats for drying. All operations were performed by the same man, and as near the same time as possible. The panels were allowed to stand one week after the last coat of varnish had been applied for hardening. They were then sawed into 1-ft. lengths and a panel of each sample sent to H. M. Butts, Albany, N. Y.; J. H. Pitard, Whistler, Ala.; T. J. Hutchinson, London, Ont.; A. P. Dane, Reading, Mass.,\* and one set was retained at Roanoke, Va.

An examination of the test panels showed that the southern climate is the most severe on varnished surfaces; that there is a difference between all the samples tested; also a difference between the results obtained on the same varnish at different points.

One of the most noticeable features of the test is the generally superior condition of panels exposed in the North over those exposed in the South. The test furnishes a good opportunity to select varnishes that might be expected to render the best service in any of the zones represented. We secured these samples with the understanding that we would not publish names, etc., therefore we will not make a detailed record of the standing of each panel. The committee will be glad to furnish detailed information to any master painter who may be interested in the test.

H. A. Polhemus (Erie); a member of the committee, submitted the following on baking enamels:

To prepare a car body for enameling, remove all grease with gasoline and, if necessary, sandblast the surface to remove all the rust and scale. This must be done to insure a perfect and lasting job. Immediately after sandblasting give the surface a thorough dusting and apply a coat of priming enamel. Never let a sandblasted job remain over night without priming, as it will rust in a very short time. A steel passenger car when shopped for general repairs can be completed in less than half the time by the enameling process than by our present air-drying system, if there are proper facilities for doing the work. If the work is properly done, enameling will outwear the air-dried job by two years or more service, and the surface of the car is easier cleaned and the appearance is 100 per cent. better.

Mr. Polhemus exhibited several interesting panels of enamel work.

The test committee exhibited other specimens, among which was a film  $\frac{5}{8}$  in. thick representing 365 coats of an oil retarded black carbon paint, each coat being applied daily during the period. When the film was finally lifted it was found that 38 per cent. of its weight had been lost, due to oxidation. Another film represented a retarded surfacing system which embodied 11 coats, applied in 12 days. Other films represented the practical oil retarding of the first class quick setting up paint oils found on the market. One was retarded with a high grade fish oil and another with the soya bean oil. It was recommended that these be given a good atmospheric test during the next year.

#### RUST INHIBITIVE PAINT.

W. A. Breithaupt and A. M. Johnsen (Pullman Company): Sheet steel as it is usually received from the mills has a surface coating of mill scale. If this mill scale coating was uniform in

\*An unfortunate circumstance connected with the set of panels sent to Reading, Mass., prevented their exposure in time to be considered with the test, therefore are not included.

thickness over the entire surface and if it would stand heat and bending without chipping off, it would be desirable to leave this coating on the steel. The fact is, however, that it does in no way fulfill these conditions satisfactorily.

The sandblast, according to our experience, is the best method for removing this scale and rust. The steel should be painted immediately after sandblasting, or if it is not convenient to do so it should be placed in a room warmer than the outside temperature in order to prevent the condensation of moisture on the steel.

Sandblasting the steel provides a sufficiently roughened surface for the paint to thoroughly adhere to. The paint coats must be of such material that the vehicle or combinations of oils and varnishes give the pigment a coating which will resist to the utmost capacity the passage of moisture and gases. The pigment must also be alkaline to a slight extent and electrolytically positive to the steel.

The Pullman Company have made a large number of tests on such protective coatings for steel and now believe that the lesser the number of coats possible to give the desired protection, the better it will last. Where previously the 7 or 8 coat system was used we found that three coats of paint would give the desired capacity and ample protection to the steel. We then began the five-coat system, applied as follows: primer, body color, varnish color and two coats of varnish. The priming coat is made with an inhibited pigment as a fundamental requirement and a vehicle of good adhering quality. The prime factor of the second coat lies in the vehicle which must be the very best moisture and gas resister that can possibly be obtained. The pigment was also a very good inhibitive. The steel plates are dipped in these two first coats and baked at 240 deg. F. for 12 hours. Cars so painted have been in service thirty months, without the slightest indication of destruction of the paint. The outside surface was entirely free from checks and cracks and as a general assertion would state that the paint was in excellent condition.

A. J. Bishop (Nor. Pac.): While the baked surface on steel is perhaps a better inhibitive coating than ordinary or even special painted surfaces, it has several objectionable features besides the one fact that it does not entirely prevent rust. J. W. Lawrie, Ph.D., in a paper before the World's Eighth Congress of Applied Chemistry, states "that while it is true that the problem of the preservation of steel is not new to us, the artistic preservation and protection of steel from corrosion is a new problem. A railway passenger coach must not only be painted carefully, but it must be painted so as to be and present a pleasing appearance to the eyes of the traveling public."

Paints for steel have different functions than those for wood; therefore in painting equipment constructed with wood and steel these functions should be carefully noted. We have not the absorption into the pores of steel only to a limited extent, and for this reason a different quality of paint is required to secure stronger clinging effects than that of the pores of wood. While it is undoubtedly true that sandblasting gives a slightly roughened surface which aids materially in holding the paint to steel, it is necessary to assist an oil paint with something that is better as an adherent to steel than linseed oil. The fewer the number of coats of paint on steel which will give the maximum protection, the longer the wearing and the better service will the paint coats give. The pigment and vehicle must be such as to exclude from the steel surfaces all moisture and gases.

It matters not what coating is to be applied, special attention should be given to the application of the priming coat especially on metal.

#### ECONOMY IN LOCOMOTIVE PAINTING.

D. A. Little (Penna.): With very few exceptions the practice of painting locomotives is not economical. The cost of engine painting has been gradually less and less in the past 18 years until now it is necessary to paint the locomotive at every shopping. H. W. Jarrett, assistant superintendent of motive power of the A

an article on British Railway Practice, recently published in the *Railway Age Gazette*, makes conspicuous comment on the beautiful appearance of the British Locomotive. He states that fourteen coats of filler, paint and varnish were applied to the jacket, cab, tender and wheel covers. This painting lasts from five to seven years, which immediately raises the question as to whether their methods or our methods are the more economical. It is evident that, apart from the question of economy, the British railway people believe in the advertising possibilities of a well-painted locomotive. Such engines give a fine balance to the general appearance of the train.

I would not advocate such an elaborate system as that of the English railways, but I would advocate a system such as was generally used about twenty years ago, which was good enough for all intents and purposes—reasonably cheap in cost and as durable as could be desired.

J. W. Gibbons (A. T. & S. F.): There are some roads that only consider the first cost when painting their equipment and endeavor to get along with cheap material. This is false economy. The Santa Fe use a good durable material for their locomotives which is applied in a thorough workmanlike manner, believing, by so doing, that the saving in maintenance will more than pay the difference between the cost of the second rate paint and the first class paint.

The steel underframe of tenders very seldom receives the protection it should. The overflow of the water and the wetting down of the coal seeping down through the coal becomes of an acetic nature, and when it reaches the underframe will lodge there and greatly augment the corrosion. One coat of paint applied when the tender is built and not maintained is not enough.

W. E. Woods (N. Y. C.): The use of cheap materials for painting locomotives has not proved economical, both from appearances and durability. The New York Central Lines are to rewrite the schedule for painting locomotives to conform to the Master Painters' Association standards.

**SAFETY FIRST.**

J. H. Pitard (M. & O.): The safety first movement which was recently launched by the railroad companies for the purpose of safeguarding the lives of their employees and the traveling public, is an act of benevolence that deserves the hearty co-operation of all departments of railroad operation to insure its success. The accidents in the paint department are perhaps too infrequent to be seriously considered and the principal question is the preventing of occupational diseases. Even these, however, are very few. They owe their origin to three principal sources: Hygienic shop conditions, unwholesome paint materials and the habits of the workmen.

There is nothing mysterious about shop hygiene, it simply means good sanitation, ventilating, and heating a shop in such a manner as will permit of the free escape of impure air and noxious gases and the admission of pure air. Failing to do this will lower the vitality of the workmen and correspondingly decrease their efficiency. Good ventilation is especially essential in a paint shop, due to the fine particles of lead dust, fumes from the paint materials and the necessarily heated condition of the shop.

With a few exceptions all paint materials are more or less unwholesome, the chief offender being white lead, which is liable to cause lead poisoning or "painter's colic." Wood alcohol, bi-sulphide of carbon, benzole, turpentine substitutes of various kinds and some other chemicals are unwholesome on account of their rapid volatile properties, their fumes permeating the shop. Such materials should be labeled, calling attention to their inherent dangers. It is possible to eliminate these detrimental odors by only using freely mixed paints and by keeping all paint stock in air-tight containers. The stock rooms should be especially well ventilated.

All employees should be compelled to keep themselves clean and should have clean overalls every week. They

should not be allowed to eat meals in the paint shop and the use of intoxicants and cigarettes at any time should be discouraged.

C. A. Cook (P. B. & W.): The solving of the problem of safeguarding ourselves and others, lies entirely within our own province, and can only be solved by the elimination of the element of carelessness so universally prominent and the development of our powers of observation. Safety appliances and rules avail themselves of no value if we allow ourselves to be careless, indifferent and disinterested in their use and observance. It has been said that 80 to 90 per cent. of injuries to railroad employees are due to their carelessness. The preservation of the health of the workman is of vital importance to the corporation that employs him and the deterioration of his vitality impairs commensurately his productiveness. The results of investigations and tests of the paint materials used in the paint shop should be carefully studied and considered when handling them in order to guard against any possibility of injury from them.

E. F. Bigelow (N. Y. C.): The absence of machinery in the paint shop does not permit a great deal to be done in the matter of safety devices, but nevertheless danger may be present and may also be overcome in a great degree. Probably the most accidents which occur in paint shops result from the use of the old style plank and horse staging, their imperfect construction and recklessness on the part of the workmen while using it. The practice of using a horse with legs of unequal lengths or having broken cleats is quite common, and with a warped or twisted plank form a very dangerous combination. A large number of accidents have occurred from this source, all of which were preventable had ordinary care been used.

Ladders used in shops having concrete floors should be equipped with movable basswood shoes, or some similar appliance, to prevent slipping. Lying face downward on car roofs to paint decks or clean deck glass is a common and very dangerous practice. In some shops this is now a dischargeable offense. Bad places in flooring, the occasional piece of wood with projecting nails lying on the floor are fruitful of sprained backs and ankles and blood poisoning, all of which may be reduced to a minimum by prompt repairs and a clear shop.

**PAINT PROTECTION FOR STEEL EQUIPMENT.**

J. F. Lanfersick (Penna.): No matter how good this kind of equipment is painted there are some other things that should be given consideration by the officials. I refer to the loading of coal cars with hot billets, slag, cinders, ashes or any other hot substances, also the striking of the sides of the cars with hammers and wrenches to start the load to fall out. If these practices are allowed to continue, it is useless to bother much about the painting of this class of equipment as they soon put the paint to the bad. The inside of the cars is not given the same attention in the way of painting as the outside. In most cases the interior does not receive any paint whatever. Before assembling the parts used in the construction of new steel equipment, all of them should be sandblasted on the exterior and given one coat of good linseed oil paint as quickly as possible after the sandblasting is completed. After the cars are constructed the outside and underneath parts should be given two additional coats of good linseed oil paint, leaving twenty-four hours between coats. After the last coat is dry the necessary stenciling should be done. This method will insure the paint to render from four to six years' service without repainting.

When this class of equipment is sent to the shop for repainting, all rust and foreign matter should be removed with the steel scraper and wire brushes from the outside and underneath parts of the cars. After the cars have been cleaned, the outside and underneath parts, if necessary, should receive two coats of good linseed oil paint, leaving twenty-

four hours between coats. After the last coat is dry the necessary stenciling should be done. As to interiors of coal carrying cars, I do not think it would pay to paint them. When refrigerator cars have steel ends, those parts on the interior of the cars should have at least one coat of paint to protect them from dampness. All other roofed steel or part steel equipment, such as automobile cars, should have all exposed steel parts painted with at least one coat of paint.

F. A. Weiss (C. of N. J.): Our steel freight equipment consists mostly of hopper coal cars and freight gondolas; the former cars are used in handling anthracite coal, which is particularly hard service. The first requisite is to remove the rust and place the surface of the steel in proper condition to receive its protective coating of paint; experience has taught us that the sandblast is not only the cheapest but the most effective way to do this.

The cars are painted immediately after the blasting is done, to protect them from moisture that may settle on them. After 24 hours the sides and ends of body are given the second coat of paint, and on the third they are stenciled and released for service, the tracks receiving but one coat. The paint we use and find to be durable is carbon black, reduced with raw linseed oil and one of the prepared extending oils. The proportions of which are determined by the quality of the extending oil.

Provided the question of time in getting the equipment through the shop were not so urgent as it is on most railroads, and also cost not considered such as essential element in the problem as it is generally regarded by the railroad management, the exterior surface of the car should be sandblasted and primed with red lead mixed with raw linseed oil, and finished with two coats of carbon black, carrying the maximum quantity of raw linseed oil, to which is added a portion of extending oil. The last coat need be applied only to the sides and ends of body. On new cars laps and joints should be given a heavy coat of red lead or carbon black before car is assembled.

Trucks which are repainted require but one coat, while new trucks should have two, carbon black being a suitable material for the purpose.

Oscar P. Wilkins (N. & W.): We have been, and expect to continue the practice of, testing out every promising material offered for the protection of steel, but up to the present time we have not found anything that will equal pure red lead and linseed oil as a primer, with two finishing coats of carbon black. A steel car surface carefully cleaned with a wire brush, scrapers, benzine and waste, primed with a freshly mixed pure red lead and linseed oil, and finished with two coats of good high grade carbon black, carrying maximum quantity of linseed oil, will give maximum wear with no increase in cost. We have been building steel cars at the Roanoke shop for several years and find fully 99 per cent. of the steel is free from corrosion, which renders it unnecessary to use the sandblast. As for the scale, I believe red lead is an inhibitor of rust, and if there is any rust under the scale the red lead, if not completely arresting its action, certainly retards it. We see this in evidence every day by steel cars that have been in constant service for eight or ten years with nothing but the initial painting, and aside from the hammer blows for loosening up the contents at certain points are in excellent condition.

#### ENAMELED INTERIOR TRIMMINGS.

John D. Wright (B. & O.): It is a well known fact that nearly all of the interior metal trimmings, lamps, parcel racks, etc., applied in passenger cars in recent years have been made of brass, and more thought seems to have been given to their design, and to the coloring of the metal, than to their cost. In other words, they have been considered more from an artistic than an economical standpoint.

The railroad companies are today confronted with conditions that force economy in many of the smaller details, some

of which, perhaps, have been overlooked in the past; and while the metal used on the interior of passenger cars may appear to be a trivial matter, in the aggregate it amounts to thousands of dollars. During the past year this point has been picked up by certain companies and it now looks as if some of the interior brass work will, sooner or later, give way to cheaper metals, and the baking enamel proposition makes this possible. Where the baked enamel finish is used many of the parts which are now removed every time a car is shopped for repairs could be cleaned with the interior of the car, without being removed and replaced. This expense would then be saved, to say nothing of the additional cost connected with the polishing, sandblasting, dipping, coloring and lacquering of brass work.

#### MAINTENANCE OF PASSENGER CARS.

T. J. Hutchinson (Grand Trunk): Maximum paint protection is a necessity in railway service and whenever these seven-day systems are introduced and hurried methods of cleaning continued at terminal points, we may look for future trouble that may be called paint failures.

When making out schedules of paint operation it must be remembered that the exterior protection lies chiefly in the varnish and whenever the service exceeds the life of the varnish it will be at the expense of the whole paint structure, which means extra time and material.

On the steel or wood-sheathed car after the primary coat I believe it will prove economical to apply not less than three coats of surfacing material where the old surfacing systems are followed. I believe that the present-day hurried method of cleaning and caring for the interior of the car en route and at the terminal point is false economy.

#### RAILWAY PAINT SHOP SUPPLIES.

H. Heffelfinger (Penna.): The best materials obtainable for painting and varnishing passenger cars and locomotives brings about the most economical results. The different localities through which the equipment is to run should determine to some extent the material to be purchased and in order to insure the correct material being secured the master painter should be consulted; he in turn being thoroughly familiar with the goods on the market. It is useless to expect good results when inferior paints and varnishes are used, and every master painter of this association should endeavor to make a reputation for doing good work and should do all that lies in his power to impress on his superior officers that he cannot attain the best efficiency in painting passenger equipment and locomotives without their aid in procuring the best and most lasting materials.

#### OTHER BUSINESS.

Other papers were presented on mirrors, the art of staining woods and paint brushes for steel cars.

F. W. Brazier, superintendent, rolling stock (N. Y. C.), in a letter to H. M. Butts, master painter of the New York Central at West Albany, N. Y., conveyed his regrets at not being able to attend the convention. He called attention to the importance of the steel car question as regards the best method of treating and preserving the steel. This problem is still in its infancy and the members by their discussions and exchange of ideas are in a position to greatly advance the art. He congratulated the convention on the interesting and pertinent subjects that were considered at this convention.

At the opening session T. J. Hutchinson, master painter of the Grand Trunk at London, Ont., presented the association with a beautiful banner painted by himself embodying the emblems of the United States and Canada. The following officers were elected for the ensuing year: President, Oscar P. Wilkins, Norfolk & Western; first vice-president, T. J. Hutchinson, Grand Trunk; second vice-president, H. Hengevelt, Atlantic Coast Line, and secretary-treasurer, for the tenth consecutive year, A. P. Dane, Boston & Maine, Reading, Mass.

# SOME FREIGHT CAR TROUBLES.\*

Poor Draft Gear and Attachments the Cause of Most of the Difficulty. Standard Test for Draft Gears Recommended.

By J. C. FRITTS,

Master Car Builder, Delaware, Lackawanna & Western.

The question has been asked as to why we are experiencing so much trouble with freight carrying equipment. In answering this question we must take into consideration the age and design of the cars and also the service they are called upon to perform. There are in round numbers about two and one-quarter millions of freight cars in the country, varying in age from one to twenty-five years, and beyond doubt a large number of the older ones are unadapted for present day train service.

Up to fifteen or sixteen years ago it was the general practice to build cars with short draft timbers extending from the



Steel Center Sills Buckled Within Twelve Inches of the Body Bolster.

end sill back to and butting against the body bolster. These draft timbers were secured to draft sills (5 in. x 8 in., in some cases 5 in. x 9 in.) with four vertical bolts. I know of some cases where this practice was in use within the last three years. As a protection to the car against shocks it was the practice to use one or two helical springs between the followers for a draft gear. Cars having draft arms and attachments of this type will not stand the strains they are subjected to in the present long trains.

One of the first things I would suggest doing to relieve the present unsatisfactory condition would be to substitute for the present short draft arm one of metal construction that will extend back of the bolster. This would lead to an inspection of such cars by their owners to determine whether any of them would warrant the expenditure necessary to re-enforce them with suitable metal draft arms and the application of a draft gear which would be a non-recoil, shock absorbing device. Cars which would not warrant such repairs or renewals should be confined to local service where the owner would be the only one to suffer the consequences of perpetuating such equipment or they should be destroyed, using the money received from the sale of scrap to apply on the purchase of new equipment. I believe if we were able to keep a record of the amount expended on each car to keep it in service we could easily prove that so much of the total amount used was being spent on a certain lot or class of cars that it would be economical to take them out of service.

The Master Car Builders' Association, at its June meeting this year, discussed at some length the question of withdrawing from interchange service all cars of 40,000 or 50,000 lbs. capacity. The discussion resulted in the following motion by D. F. Crawford:

"I would move that a committee of this association obtain from each of the members the situation as to each of their cars and ascertain if it would not be possible to make recommendation to the American Railway Association which will permit that for the benefit of the traffic conditions of the country we may set aside the older cars which are giving every one of us trouble that are moving them." The motion was carried.† This is a move in the right direction for instant relief and it behooves us as members of the Central Railway Club to get in touch with the committee as soon as it is appointed and render all the assistance in our power. I believe, however, the question is one of draft timbers, draft gear and buffing arrangement more than capacity, or even age. However, should we eliminate the old cars, we still have a large number left that are giving a great deal of trouble in the way of broken draft sills, draft timbers, end sills, couplers, etc., and with such cars it is often hard for the mechanical man to decide the most economical method to follow.

Careful investigation indicates that the stresses due to buffing and pulling have more than doubled in the past ten years so that cars built to meet conditions of ten or twelve years ago are not able to stand present day service without serious damage resulting to themselves as well as adjacent equipment. It can



A Common Failure in the Older Freight Equipment.

hardly be expected that the cost of maintenance due to failures will remain constant with the same equipment under such varying conditions of operation.

One of the very common failures in the older class of equipment is shown in one of the illustrations. It will be noted that the draft timber bolts have been pulled completed through the center sills which were of sound material and properly applied, the car simply having been subjected to greater stresses than it was possible for it to withstand. Due to the age and construction of this type of car the expense of applying proper re-enforcements would not be justified, and if the cost to maintain

\*Extracted from a copyrighted paper presented before the Western Railway Club, Buffalo, N. Y., September 12.

†Daily Railway Age Gazette, June 18, 1913, pages 1488-9.

the older equipment were kept separate from the newer and stronger cars it could be easily shown that the proper course to pursue would be to destroy them and apply the scrap credit to new cars. There are, however, a large number of cars built at a later date that are subject to frequent failures, partly due, it would seem, to faulty construction. Many of the buffing parts have been constructed more from a theoretical standpoint than a practical one. Draft arms that extend only from the end sill to the body bolster should not be used in any case. They are the cause of numerous failures together with resultant interruptions of traffic and should be replaced either by the continuous steel construction or long metal arms in connection with open bolsters, locking them with both the top and bottom members. The general condition and age of the cars have to be taken into consideration when deciding which method of reconstruction should be used. This is the real problem for mechanical men to work out.

Steel center sills buckled within twelve inches back of the body bolsters are shown in another of the illustrations. It is thought by some car designers that if steel members are tied together at a distance in proportion to the width of the flange, it is sufficient and will meet all requirements. This practice may be mathematically correct but it does not prove out in service.

Another type of steel underframe construction that is giving considerable trouble is that in which, while the center sills have been properly tied and strengthened between the bolsters, one of the most vital points has been overlooked; i. e., the draft arm, made of pressed steel shapes, is riveted to the center sills which have no cover plate, or other means of tying them together, resulting in frequent serious damage and delays to both equipment and lading. The experience of the writer indicates that riveting the draft arms to the center sills to facilitate repairs does not make as strong a construction as continuous sills. It forces a weak construction to start with, because, in order to make such a connection secure against buffing shocks and pulling stresses, a large number of rivets must be used in making the connection, and the holes for the rivets are sure to weaken the structure; but in either case cover plates should be used. The top one should extend from end sill to end sill and the bottom one as far through the bolsters as possible without interfering with the movement of couplers or draft gears.

The part of the car designed to withstand the buffing and pulling stresses is giving more trouble than all the other parts taken together and for this reason must be strengthened. There are two methods used in re-enforcing old equipment.

First, for the older types of cars that we do not feel justified in going to the expense of providing with steel underframes, some roads are using a metal draft arm instead of the old oak timbers. These metal arms are being made of steel castings or standard rolled steel shapes riveted together in such a manner as to prevent the sills from spreading. I have tried both kinds and favor the steel casting for the reason that it withstands greater buffing stresses and can be moulded into one piece for each arm, making fewer parts for repair men to handle; the only extra parts needed are two or three tie plates riveted from arm to arm so as to make them both act together in receiving the shocks. Furthermore, the metal can be moulded in any shape, which allows of a distribution to give maximum strength. These arms, starting at the striking plate, should pass back through and over the transom for a distance of at least 24 in. and have square butting ends to receive a good stiff compression timber secured to the under side of the center sill.

In one of the latest designs of this type of steel casting draft arm, the compression timbers are placed in line between the needle beams and from each needle beam to the butting face of the metal draft arm. They should also be fitted so tightly that a jack is required to get them in place, and they should be of a good stiff section, at least 5 in. x 6 in. This type of re-enforcing, including a modern friction gear, can be applied to a car for approximately \$135.00 and I feel sure it is all that is necessary

for a very large number of the old cars that are now giving trouble.

The other method is to apply steel underframes complete at a cost of perhaps three times that of steel arms. This is pretty expensive but there are a large number of cars that will warrant this expenditure. Some of these underframes have been giving considerable trouble; therefore, we should look carefully into these troubles and design future frames with a view to overcoming them. In one of the latest types of steel underframe construction, which it is believed has the greatest strength for a given weight, the center sills are continuous and the cover plates extend through the body bolsters as far as the construction will permit. Auxiliary cover plates at the center are provided, both top and bottom. The body bolsters have been carefully considered, a few extra pounds of metal at this point will bring good results. Securely riveted to the center sills is a top plate 20 in. wide, which will throw a great deal of strength into the center column over the center plate, where the failures show we have the most work to do, and also acts as a gusset, strengthening the frame against lateral forces. The back lugs have been extended to the bolster and act as stiffeners for the sills. The area of the cross section at the bolster is between 24 and 25 square inches, which it is believed should be the minimum for a thirty-ton car. The center line of the coupler has been placed one inch below the neutral axis of the center members, this being a feature which does not seem to have been given proper consideration in the past. By keeping the force thrown against the car near the center of the draft sills, not only the liability of buckling but the breaking down at the bolsters is reduced to a minimum. Car designers should arrange the trucks and underframes so that this can be accomplished.

Experience from service conditions indicates very strongly that a modern friction draft gear gives the greatest protection, thus reducing the cost of maintenance and all other expenses incident to car failures. A very careful check of cars placed on shop tracks for repairs, in several parts of the country, shows that an average of 71 per cent. are so placed on account of defects that have developed due to shocks, and of a lot of 1,000 cars recently transferred it was found that over 80 per cent. of the failures were also due to shocks. Investigation of the cause of damage to lading indicates that a large percentage can be traced to the same cause. If these shocks are responsible for so great an expense to the railroads in general, what should be done to relieve the equipment? The desired results will never be obtained unless some device, between the frame and the coupler is installed, which is especially designed to destroy or absorb the force of the blow. Springs varying from 18,000 to 60,000 lbs. capacity have been tried and gave good protection some years ago when cars were of light capacity and handled in short trains, but they do not meet the requirements of today. A large number of railroads, realizing this, have started to replace the spring gear with friction devices that have from three to four times the shock absorbing capacity that it is practicable to obtain from a spring gear. In a device of this kind there should be no recoil. The force exerted by the recoil of a spring is practically as great as the force to compress it and results in much damage to equipment, especially in long trains.

The following statement gives the actual comparative service performance of these two types of gears, covering a period of twenty-six weeks, and shows very clearly the superiority of the friction gear:

	Number of Broken										Number of Cars Equipped.	Per Cent. of Failures
	Couplers.	Knuckles	Knuckle Pins.	Pocket Rivets.	Pockets.	Followers.	Springs.	Draft Spring Castings.	Total Failures.			
Various types of spring gears....	1526	710	2421	3143	207	1102	1620	1482	12211	15000	81	
Various types of friction gears...	168	93	438	86	12	6	21	4	828	4805	17	

The information was compiled from weekly reports submitted by inspectors and shop foremen at every point on the entire

system where repairs were made and is impartial and correct. The statement is self-explanatory and needs little comment. The majority of the spring gears were applied to wooden cars, which to a certain extent, form a cushion themselves and greatly protect the parts susceptible to failures. In order to obtain a correct comparison, only defects that are common to both wooden and steel cars were considered, otherwise the results would have been much more favorable to the friction gear. It is interesting to note that on 4,805 cars equipped with the friction gears there were 828 failures, or 17 per cent. of the total number of cars, while of the 15,000 cars equipped with spring gears 12,211, or 81 per cent., failed, a difference of 64 per cent. in favor of the friction device. A reduction of car failures of this magnitude means a great saving to the railroads in general because of the increased earning power of the cars and the decreased cost of maintenance, lost and damaged lading accounts, delays and interruptions of traffic, transfers of lading and switching through the various terminals. The sum total cannot be estimated, but that it represents an enormous figure I believe we will all agree. It will also be noted that for every coupler broken there were 1.7 knuckle pins which failed, showing that this is the weakest point in the car coupler. We know that the manufacturer as well as the M. C. B. Committee on coupler designs is considering this point and arranging to relieve the knuckle pin of a large part of the work the present design of coupler throws upon it.

I fear that some users do not appreciate what a draft gear is called on to do. I am free to confess that up to the time I started to investigate this question some years ago, I did not credit it with being such an important factor in the question of car maintenance, and other expenses incident to car failures. It is the only device that we apply to a car to protect it and its lading from damage. It has no other function to perform. It must destroy shocks from impact, shocks from pulling and shocks due to recoil. I will try and point out a few of the damages occurring to cars because of the draft gear failing to perform the work for which it is intended.

If it were possible to put a draft gear between the coupler and the car that would absorb the heaviest shock, we would eliminate broken couplers, and their removal would not be necessary until they are worn out, and I believe the coupler bodies of late design are sufficiently strong to last approximately the life of a car.

While knuckles wear out in service, there are a great many of them that break from shocks, and here again the draft gear that will relieve the coupler from shock also relieves the knuckles.

The failures of coupler yokes are due to shocks, and I think coupler yokes are being replaced by other forms of attachments, on account of pocket rivet failures which are due to the rivets being in shear under impact. In several years' investigation of the draft gear question I have satisfied myself that by eliminat-

ing this feature, the wrought iron, or forged steel yoke, with 1 1/4 in. x 5 in. section riveted to the coupler with two 1 1/4 in. rivets can be operated with very few failures.

I think no one will deny that draft springs are destroyed by shock, and with a properly designed friction draft gear I have learned that this failure can be reduced to a very low figure, for the reason that the draft springs are not driven solid even though the draft gear receives a shock sufficient to close it.

The end of a car is often burst by the lading it contains or the lading from an adjacent car. In either case it is on account of the lading moving in an effort to perform the work that the draft gear should have done. I believe that more attention should be given to re-enforcing this part of the car. It is also shock that does the greatest amount of damage to side doors.

Everyone knows of the trouble we are having with car roofs, and I think it will be agreed that it would be very little trouble to apply a satisfactory roof, if the car was standing still all of the time, but the roof being located so far above the floor line and the coupler below the floor line, with a more or less weak construction between the roof and the floor, it cannot help but be racked to its final destruction by the shocks delivered to the car through the coupler. It has been stated that a poor roof will last longer on a car equipped with an efficient draft gear than a good roof on a car with a poor draft gear. The writer is not in a position to either contradict or confirm this statement, but I do know that by replacing an inferior gear with an efficient one is equal to strengthening every part of a car that is susceptible to failure from shocks.

In closing, I have to offer as a relief to the present situation:

*First*—Re-enforcing the older types of cars that will not stand the expense of a steel underframe, with a long metal draft arm that extends through and over the body bolster; this in turn to be re-enforced, or backed up with good, heavy compression timbers.

*Second*—On such cars as will permit of the expenditure, the application of a carefully designed steel underframe.

*Third*—In all cases apply the draft gear that will destroy the greatest amount of shock with the entire elimination of recoil.

*Fourth*—The adoption of a standard specification for the testing of draft gear to determine its shock absorbing capacity, and amount of recoil, before purchasing.

*Fifth*—Substitute for the present wooden roof an all metal one as soon as it has been demonstrated what the proper construction should be.

**NEW WESTERN PACIFIC FERRY STEAMER.**

The new ferry steamer "Edward T. Jeffery," built for operation between San Francisco and Oakland, in connection with Western Pacific and Denver & Rio Grande train service, was



Engine House of New Ferry Steamer Edward T. Jeffery.



launched on July 19 and, after a trial trip on August 11, was placed in regular service August 15. The vessel is a double-end screw ferry with the following dimensions: length over all, 230 ft.; beam over guard, 62 ft. 6 in.; beam moulded, 42 ft.; depth moulded, 19 ft. 6 in. The hull of the vessel is steel throughout and is divided into a number of watertight compartments by five transverse watertight bulkheads and by longitudinal bulkheads on each side extending completely through the engine and boiler rooms. The vessel is equipped with engines capable of developing 2,000 i. h. p. The boiler room contains four Babcock and Wilcox safety water tube boilers with a total heating surface of 10,000 sq. ft.

The seating capacity of the boat is in excess of 1,200 passengers, with standing room for three times that number. On the main deck there are provided; in addition to the seating accom-



New Western Pacific Ferry Steamer.

modations, gangways for baggage, trucks and express wagons and galley, restaurant and dressing rooms. The interior on the main deck is finished throughout in white. On the saloon deck there is a large and completely equipped restaurant connected with a dumbwaiter on the galley with the main deck below. The cabin on the saloon deck is finished in mahogany and is provided with a raised omnibus roof for ventilation, the sash in the sides of this roof being fitted with art glass. The vessel is lighted throughout by electricity.

Particular attention has been paid to the fire protection system. There is a large fire pump in the engine room running constantly, this being connected by lines of piping to the hose reels situated at convenient points on both decks. As the pump is constantly in operation and the pipes are always full of water, a stream from the fire hose can be turned on instantly.

**NEW LOCOMOTIVES FOR AUSTRALIAN RAILROADS.**—A return has been issued by the New South Wales railroad department showing what is being done in the direction of new locomotive equipment. It is shown that the 20 engines ordered from the North British Company have now been supplied. At the Clyde Engineering Works, Sydney, a contract is being fulfilled for 50 additional engines of the same class. These are being delivered at a rate involving a monthly expenditure of \$77,860. In addition to these engines, an order for 40 other engines is being carried out at the Eveleigh workshops, near Sydney. At the same shops 40 engines, of slightly different type, are being turned out. The federal government is also making provision for locomotives for its transcontinental line from Port Augusta, South Australia, to Kalgoorlie, Western Australia. An order for four engines has been placed with the Clyde Engineering Works at a cost of \$115,000. Foreign bidders tried for this order, but although an American firm tendered approximately \$90,000 (\$25,000 less than the Clyde works), the Australian concern secured the business. This is interesting as showing the trend toward supporting local industries.

**THE ARMSPEAR SPHEROIDAL LENS.**

This lens, designed to widen the territory from which a switch or signal light can be seen, is in use on the Long Island and other roads for tail lights for trains and in other situations. It is useful especially in tail lights on roads having many curves; and in switch lights, at isolated points where the approach is on a curve from which the switch is visible a considerable distance away. With the ordinary lens, designed to transmit light in approximately parallel beams a switch light may be almost or quite invisible at a short distance because of the impossibility of fixing the lamp in a position to throw its rays toward more than a small part of the area through which an approaching train passes. Likewise, a light, even where the line of road is straight, may become ineffective from a slight error in alinement of the lamp or from looseness on the bracket due to lack of care or neglect in maintenance.

The spheroidal lens has been shown by tests to project red, green and white light, as compared with the ordinary 5 3/8 in., smooth face, semaphore lens, as below, the wick being 5/8 in. wide and the flame measuring less than 3 candle-



Fig. 1.



Fig. 2.

power. The colored roundels used in these tests, placed in front of the white lens, were 8 3/8 in. in diameter:

	Armspear lens.		Common lens.	
	Distance, Miles.	Spread, degrees, either side of axis.	Distance, Miles.	Spread, degrees, either side of axis.
Green .....	0.81	45	0.81	10
Green .....	1.00	45	1.00	9
Green .....	2.00*	45	2.00	6
Green .....	3.00	..	3.00*	4
Red .....	3.00	45	3.00	4
Red .....	3.29*	45	3.29	3
Red .....	4.00	..	4.00*	2
Uncolored .....	4.37*	45	4.37	2
Uncolored .....	5.60	..	5.60*	1

\*Maximum distance at which this light could be seen.

It will be seen that though, with the spheroidal lens the light cannot be seen so far, it can be seen through a lateral range of 90 degs., and that it can be seen an ample distance for all practical purposes; two miles for green and 3.29 miles for red.

The illustrations show the section of the lens (Fig. 1) and the switch lamp (Fig. 2). The four glasses in the lamp are held fast by means of a locking arrangement at the top, controlled by a key, and can be readily changed; so that a single design of lamp answers for a switch light where two colors are needed, a tail lamp with four (three green and one red) or a semaphore, where only one color may be needed. For a semaphore the standard R. S. A. socket is fixed to one side of the lamp, and for a tail light the usual bracket is attached, by a ring, at the bottom.

This lamp is made by the Armspear Manufacturing Company, 447 West Fifty-third street, New York.

# Maintenance of Way Section.

THE October Maintenance of Way Section will be published in the issue of October 24 instead of October 17, in which it would regularly appear. This change is made in order to allow a full report of the convention of the American Railway Bridge and Building Association, which will be held in Montreal, October 21 to 24, inclusive, to be included in the Section.

IT is not necessarily a universal condemnation of the morals of section foremen to say that it is important to have them make daily reports of the labor used on their sections, but it would be contradictory to fact to say that all incorrect monthly time rolls are due to lapses of memory. A system which requires a daily report makes petty grafting very difficult, and such a system should be welcomed by the honest foreman because it eliminates charges of dishonesty which might result at present if he unconsciously errs in making out his monthly payroll. Daily reports, such as those described elsewhere in this issue are not new, but their adoption has not been general on account of the clerical work involved. The roads that have tried these systems, however, are now their strongest advocates.

THE scarcity of efficient maintenance labor makes it essential that every effort be put forth to keep in the service the good men that are secured. Many roadmasters and supervisors are working on various systems of holding their laborers and keeping them satisfied and, in many instances, are securing good results. We expect to publish in the next Maintenance of Way Section short discussions from several men who are using novel plans for holding labor, and we solicit contributions from all who are interested in this subject and who have any suggestions to offer. Special attention will be given contributions describing plans actually tried out. Contributions must be received by the Engineering Editor of the *Railway Age Gazette*, 608 South Dearborn street, Chicago, by October 10, and those accepted will be paid for at space rates.

THE suggestion made by Mr. Park in his address before the Roadmasters' convention in Chicago last week, that these men can exert an important influence to assist their roads in combating the present wave of unreasonable legislation is an important one. No other railway officer comes in contact, directly and indirectly, with as many residents along his line as the roadmaster. The railroad is a neighbor to adjoining farmers, and as such has the usual problems of fence maintenance, stock claims, etc. In these matters the roadmaster, either directly or through his section foremen, comes in contact with these people continually and can make many friends for his road. While the roadmaster and section foreman have stood out conspicuously for their loyalty in these days of organized labor, they have not perhaps realized the opportunity they have to influence public sentiment in favor of the railways.

AT no recent convention of the Roadmasters' Association has there been such an evident desire to carry on work to the exclusion, if necessary, of the entertainment features, as was evident this year. This tendency was illustrated on Thursday afternoon. When it became evident that the discussion of one of the committee reports could not be completed at the morning session to permit the members to attend a baseball game previously arranged for that afternoon, the members decided almost unanimously to substitute an afternoon session for the game. This spirit was in evidence throughout the entire meeting, and was shown in the discussion, as well as in the close attention given to the exhibits. The success of this year's convention was largely due to the increased interest in the work of the association, stimulated by the selection of live subjects and aided by the adoption of a central location for the convention. The

discussions were more spirited and practical than in previous years, and were frequently prompted by the president, who urged the presentation of data based on actual experience.

## THE CONTRACTING OF MAINTENANCE WORK.

IN considering the subject of the contracting of maintenance work it must be borne in mind that such work is of two classes which are radically different. In one class may be grouped all work not directly affecting the movement of trains, such as the mowing of right of way, the making repairs to buildings, platforms and fences, plumbing, etc. In the other class is included the actual maintenance of track and bridges, comprising the greater portion of maintenance work.

Considerable progress has been made in contracting work of the former class, as was brought out in the discussion of the report on this subject presented before the Roadmasters' Association last week, and it would seem that there exists an opportunity for a wider application of this method to advantage. The Erie's practice of contracting minor repairs on station buildings to local men, and permitting the agent to pay for this work promptly upon its completion from his cash on hand up to \$25 on authorization of the division engineer, has been described in these columns. The contracting of the mowing of right of way to farmers along the line is commonly followed and usually not only results in a saving to the railway, but creates a better feeling in the community. The handling of such work in this way in these times of labor shortage, which is more acute on the railways than in the small farming communities, allows the employment of the regular forces on the more urgent track work.

In the case of the maintenance of track and bridges, however, a different condition prevails, and comparatively little progress has been made in the contracting of such work. The contracting of section work upon a lump basis to a foreman was tentatively tried on one or two sections on the New York Central lines, but abandoned in a short time. Another eastern road contemplated contracting the renewal of ties, but the subject was dropped because of labor difficulties. The contracting of the maintenance of track and bridges differs from the contracting of other maintenance or construction work in that a large part of railway maintenance is preventive rather than remedial, and the thoroughness and efficiency of such work depends on the care and judgment of the foreman. The routine inspection of track and bridges, the removal of brush from above the bridges, and similar duties are fully as important as the renewal of ties and rails or the replacing of defective stringers. Work of the first kind cannot readily be paid for on any other basis than on a day basis, as at present, and the contracting of it on any other basis, with the resulting division of responsibility, will have a tendency to increase the hazards of railway operation.

The moving of trains should be the prime objective of all railway employees. The object of a contractor, on the other hand, is to accomplish the piece of work in hand as rapidly as possible. If these interests conflict, as they cannot fail to do in maintenance work, it is only natural that the contractor shall take chances in order to avoid delay to his work. Again, in handling any work where delays from traffic must be considered, a contractor must for his own protection, bid on the basis of the maximum delays to be apprehended, while, although delays from traffic to railway forces increase the cost of the work, they also bring increased revenue into the railway treasury. Railways can only let work in small contracts to the greatest advantage, for contracts large enough to warrant contractors recruiting large forces would result in organizations similar to those now employed by the railways with the attendant difficulties of securing labor and of supervising it that the railways now meet. Another point is that the employees of the maintenance department are now called on for all kinds of emergency duty, from clearing wrecks to breaking strikes, and the value of such services must be considered in this connection.

## Letters to the Editor.

### ANOTHER METHOD FOR CALCULATING FROG ANGLES.

HARRISBURG, Pa., August 16, 1913.

TO THE EDITOR OF THE RAILWAY AGE GAZETTE:

In the *Railway Age Gazette* of August 15, 1913, F. W. Rizer shows the results obtained by calculating the angle of a frog of any given number by the two common methods, namely: by the sine formula and the tangent formula. A third method can be used in which no tables are required.

In the figure representing the angle of a No. 10 frog, AB is assumed to be 0.5 ft. if the sine formula is used and the same assumption is made for AD when the tangent formula is used. If the arc AC, whose length is intermediate between AB and AD is assumed to be 0.5 ft., then the arc AE is 1 ft. and the frog angle which is the angle subtended by this arc is equal to one-

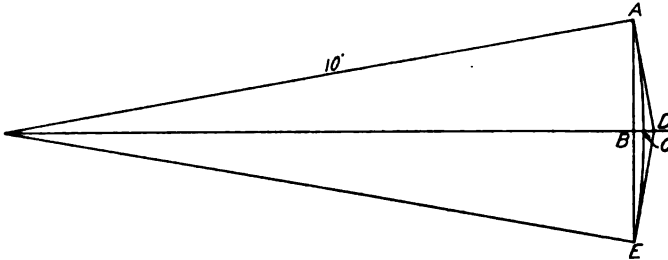

Line Diagram of a No. 10 Frog Angle.

tenth of a radian. A radian contains 57.3 deg., a number which is familiar to all who have worked with railroad curves. Hence, the angle of a frog can be found by dividing 57 deg. 18 min. by the number of the frog. These results will always lie between those secured by the sine and tangent methods, their differences from those calculated by Mr. Rizer with the sine formula being 2 deg. 11 min. for a No. 4 frog, 37 min. for a No. 6, 15 min. for a No. 8, 7 min. for a No. 10, 1.5 min. for a No. 15, and 0.3 min. for a No. 20. Such errors as these can frequently be overlooked for the sake of a handy rule of thumb.

J. M. FAIR.

### CALCULATING FROG ANGLES.

CHICAGO, Ill., August 23, 1913.

TO THE EDITOR OF THE RAILWAY AGE GAZETTE:

The point raised by F. W. Rizer in his article on "Two Methods of Calculating Frog Angles," in the *Railway Age Gazette* of August 15, was very thoroughly discussed a few years ago on the floor of the convention of the American Railway Engineering Association in connection with the report of the Track Committee. The committee's recommendation that the tangent method for computing the frog angle be adopted finally prevailed and this method is embodied in the association's Manual of Recommended Practice. The writer has maintained for some time that many of the engineering field books are in error in regard to track and switch formulae, but in this particular instance it would seem a pretty broad statement to say that the A. R. E. A. had adopted the tangent method "for some unknown reason." It has only been necessary once in the writer's experience to compute accurately a table of frog angles. In this case the tangent method was used with as little inconvenience, it is believed, as would have been experienced with the sine method. For all practical purposes there are dozens of tables giving the frog angle to the nearest minute, which is as close as the frog will be made and the work staked out. As a matter of fact, the writer in drafting uses a compass to lay off frog angles, which is equivalent to using the sine method. In measuring the angle of frogs already in track, one uses a match, pencil, 2 ft. rule or whatever is convenient, and very probably secures a result between that of the tangent and sine method, but accurate enough for all purposes. It is probably impossible to

tell whether a frog drawn with the ordinary drafting instruments to any customary scale is laid out by the tangent or sine method, so from a practical standpoint there is little difference.

From the viewpoint of the field book authors and the American Railway Engineering Association, there is a logical reason why the sine method should not be used. When switch and track formulae are carried beyond the frog the sine method is not readily and consistently incorporated in the most convenient formulae. Some of the simplest and most commonly used track formulae are derived from the definition of the frog angle by the tangent method and are easily and consistently proved to be true when we consider the frog angle F to be equal to thrice the

angle whose tangent is  $\frac{A}{B}$ , as shown in Fig. 2 of Mr. Rizer's article.

S. S. ROBERTS.

### ABSTRACT OF ENGINEERING ARTICLES SINCE AUGUST 15.

The following articles of special interest to engineers and maintenance of way men, and to which readers of this section may wish to refer, have appeared in the *Railway Age Gazette* since August 15, 1913:

New "Soo" Freight Terminal at Chicago.—A very complete freight terminal located near the heart of the city of Chicago has been built for the Minneapolis, St. Paul & Sault Ste. Marie, which solves in an unusual manner the problem of keeping open the streets across the site of the terminal and at the same time providing an unobstructed area for tracks, warehouses and team ways. The details of this new terminal were described and illustrated in the issue of August 22, page 321.

One Plan for Solving the Chicago Terminal Problem.—A letter to the Editor by Gustave E. Lemmerich, proposing a union station layout for the city of Chicago to be used by all roads except the North Western and the Illinois Central, was published in the issue of August 22, page 320.

An editorial note calling attention to the necessity for co-operation between the legal departments and engineering departments as to proposed legislation was published in the issue of August 22, page 315.

The Darjeeling Himalayan Railway.—A general description of a 2 ft. gage road which climbs the Himalayas on a 4 per cent. grade, was published in the issue of August 22, page 327.

Construction of New Quebec Bridge Piers.—Unusual interest has been aroused by the project to construct the longest cantilever bridge in the world over the St. Lawrence river near Quebec. The unusual features of the foundation work for this structure, including the building and launching of cofferdams which have rarely been exceeded in size, were described in the issue of August 29, page 365.

Nomographic Method for Finding Center of Gravity and Moment of Inertia.—A simple and convenient method of finding the center of gravity and the moment of inertia of rail sections by the use of nomograms and common graphical methods, which was worked out by M. J. Eichorn, Chicago, was published in the issue of August 29, page 381.

An editorial note calling attention to the important railway developments which are taking place under the stress of competition between the great systems in the Northwest was published in the issue of September 5, page 398.

New Ohio River Bridge at Kenova, W. Va.—The Norfolk & Western has replaced a 3,942 ft. bridge over the Ohio river, placing the new structure on the old piers without any interruption to traffic. The unusual features of this work, including the methods of cutting off the piers and erecting the new steel from material tracks carried outside the trusses, were described in the issue of September 5, page 407. An editorial note, commenting on the difficulties of erection of the Kenova bridge and the methods used in this work, was published in the same issue, page 400.

Valuation of Kansas Railways.—A discussion of the methods used by the Public Utilities Commission of Kansas in valuing the railway properties of that state, which was abstracted from the first report of the commission, was published in the issue of September 5, page 424.

Mountain Railway Electrification.—Numerous studies of the economies to be effected by the electrification of steam trunk lines have been made, most of which were prepared by electrical engineers and strongly favored such electrification projects. An abstract of a paper by Allen H. Babcock, electrical engineer of the Southern Pacific, published in the issue of September 12, page 447, discusses this problem with reference to the Tehachapi Pass of the Southern Pacific and reaches somewhat different conclusions. An editorial note commenting on the importance of this paper was published in the same issue, page 441.

Construction of the Portland, Eugene & Eastern.—Certain branch lines of the Southern Pacific near Portland, O., are being electrified and connecting links built to form the Portland, Eugene & Eastern system. This work of construction and electrification was described and illustrated in the issue of September 12, page 453.





Section                      - TIME ROLL Section No. 1000 W. 3

NAME	Occupation	Days															
		1	2	3	4	5	6	7	8	9	10	11	12	13	14	15	16
1. Michael J. Callahan	Fireman	/	/	/	/	/	/	/	/	/	/	/	/	/	/	/	/
2. James Comaria	Asst. Fr.	/	/	/	/	/	X	X	X	X	X	X	X	X	X	X	X
3. Charles Smith	Track W.	6	6	6	6	6	6	6	6	6	6	6	6	6	6	6	6
4. George Agliano	Laborer	5	5	5	X	5	5	5	5	5	5	5	5	5	5	5	5
5. John Brown	Laborer	5	5	5	X	5	5	5	5	5	5	5	5	5	5	5	5
6. Frank Jones	Laborer	5	5	5	X	5	5	5	5	5	5	5	5	5	5	5	5
7. James J. Mahoney	Laborer	5	5	5	X	5	5	5	5	5	5	5	5	5	5	5	5
8. William Scott	Laborer	5	5	5	X	5	5	5	5	5	5	5	5	5	5	5	5
9. Frank Vaccaro	Laborer	5	5	5	X	5	5	5	5	5	5	5	5	5	5	5	5
10. Mike Zunno	Laborer					5	5	5	5	5	X	5	5	5	5	5	5
TOTAL		72	73	72	75	77	82	82	61	61	1/2	62	67	72	72	72	72

Minnesota Division. Month of September 1913

NAME	Occupation	Days																TOTAL TIME	LETS OF PAY	AMOUNT OF WAGES	DEND. TIME	REMARKS
		17	18	19	20	21	22	23	24	25	26	27	28	29	30	31						
1. Michael J. Callahan	Fireman	/	/	/	/	/	/	/	/	/	/	/	/	/	/	/	/	24	1/20	60.00		
2. James Comaria	Asst. Fr.	X	X	X	X	X	X	X	X	X	X	X	X	X	X	X	X	24	5/20	96.00		
3. Charles Smith	Track W.	6	6	6	6	6	6	6	6	6	6	6	6	6	6	6	6	342	15	57.90		
4. George Agliano	Laborer	5	5	5	X	5	5	5	5	5	5	5	5	5	5	5	5	80	15	12.00		Time Given
5. John Brown	Laborer	X	X	X	X	X	X	X	X	X	X	X	X	X	X	X	X	265	15	38.25	2.50	
6. Frank Jones	Laborer	X	X	X	X	X	X	X	X	X	X	X	X	X	X	X	X	260	15	39.00		
7. James J. Mahoney	Laborer	X	X	X	X	X	X	X	X	X	X	X	X	X	X	X	X	257	15	35.55		
8. William Scott	Laborer	5	5	5	X	5	5	5	5	5	5	5	5	5	5	5	5	130	15	20.10	1.00	Time Given
9. Frank Vaccaro	Laborer	X	X	X	X	X	X	X	X	X	X	X	X	X	X	X	X	260	15	39.00		
10. Mike Zunno	Laborer	X	X	X	X	X	X	X	X	X	X	X	X	X	X	X	X	204	15	34.60		
TOTAL		12	62	62	62	62	62	62	1/2	62	62	62	62	62	62	62	62	772		337.40		

Illinois Central Monthly Time Roll Form.

2-18-11-585



Form 2347.

Chicago, Burlington & Quincy Railroad Company.

DAILY RAIL AND TIE REPORT.

Section or Gang No. \_\_\_\_\_ Location \_\_\_\_\_ Date \_\_\_\_\_ 1913

RAIL RECEIVED				PATTERN WEIGHT				TIES RECEIVED			
Car Initial and Number	Point Received From	Quality of Rail	PATTERN WEIGHT				Car Initial and Number	Point Received From	NUMBER OF TIES		
			LB. Number of Feet	LB. Number of Feet	LB. Number of Feet	LB. Number of Feet			Hard Wood	Soft Wood	
RAIL SHIPPED				PATTERN WEIGHT				TIES SHIPPED			
Car Initial and Number	Point Shipped To	Quality of Rail	PATTERN WEIGHT				Car Initial and Number	Point Shipped To	NUMBER OF TIES		
			LB. Number of Feet	LB. Number of Feet	LB. Number of Feet	LB. Number of Feet			Hard Wood	Soft Wood	
RAIL USED				PATTERN WEIGHT				TIES USED			
PATTERN WEIGHT				Quality of Rail	Show whether Main, Passing, Side or Industry track Rule 2.	NUMBER OF TIES		Show whether Main, Passing, Side or Industry track Rule 2.			
LB. Number of Feet	LB. Number of Feet	LB. Number of Feet	LB. Number of Feet			Hard Wood	Soft Wood				
RAIL TAKEN OUT OF TRACK				PATTERN WEIGHT				REMARKS			
PATTERN WEIGHT				Quality of Rail	Show whether Main, Passing, Side or Industry track Rule 2.	REMARKS					
LB. Number of Feet	LB. Number of Feet	LB. Number of Feet	LB. Number of Feet								

FOREMAN.

INSTRUCTIONS FOR REPORTING RAILS AND TIES

1. This report should show actual transactions of Rails and Ties and should be sent to the Superintendent daily.
2. Under name of track show whether Main, Passing or Side Track (Freight, Passenger or Freight and Passenger). If Track is known by name or number or is a joint facility track, show such information on this report.
3. When the Section or District the Extra Gang is Working on extends over more than one accounting division or state, special care should be taken to show the transactions of each Accounting Division or state separately.
4. See that proper addition is made for the number of feet contained in leads and that proper deduction is made for the number of feet contained in frogs.
5. Report all ties as hardwood and softwood, according to the General Manager's Standard Tie Classification.
6. When no rails or ties are received, shipped, taken up or used, blank report should be sent to the Superintendent.



into the subgrade, the slabs will entirely prevent this action.

The embankment being of clean gravelly material and quite porous, it was found by trial that enough of the grout seeped into it to increase the nominal thickness of the slab about 2 in. if the ground was dry; but when a hose was used, in order to settle the earth as much as possible before casting the slab, the nominal thickness was not much increased. The concrete was composed of one part Portland cement, three parts sand and six parts of 2 in. broken limestone or trap rock, all hand mixed and very wet. Just before initial set, the slab was sprinkled over with broken stone, to provide a better bond for the ballast, and thus minimize the tendency of track and ballast to shift, especially laterally due to the sharp deflection of moving trains. The use of rods or mesh for reinforcing the slabs was at first thought necessary, but upon attempting a rational design, it was concluded to omit all reinforcement, and consider the concrete slab to act like a pavement rather than a spread footing.

The work comprises the support of 50 crossings and switches, mostly No. 10 with about 90 foot leads, 32 of which are west and 18 east of the station, the total area covered being about 70,000 sq. ft. The average cost per switch or crossing was about \$90. The cost of labor for clearing the site, excavating, building runways and mixing platforms, unloading and handling material and mixing and placing con-

### RAIL ANCHOR TESTING MACHINE.

A machine for making a practical test of rail anchors has been designed and built by the Q and C Company, New York, which is being used for regular tests at the company's offices, and will be exhibited for advertising purposes whenever occasion offers. The machine formed the principal part of the company's exhibit at the Roadmasters' and Maintenance of Way Association convention in Chicago, September 9-12.

The anchor to be tested is placed on the base of a short length of 100-lb. rail in the same manner as in the track, and by moving this rail longitudinally the anchor is pushed against a block held in place by a heavy spring so that a pressure of 1,000 lbs. is applied at each blow. The rail is carried in bearings on castings which allow a movement of 6 in., the power for operating the machine being secured from a ½ h. p. 110-volt d. c. motor mounted on a bed plate casting adjacent to the rail supports. This motor can be driven by attaching a cord to any light sockets and as the operating machinery is enclosed in a substantial box the machine can be readily moved and quickly attached for a test. The speed of 1,700 r. p. m. at which the motor runs is reduced to 30 r. p. m. by a worm gear which drives a shaft to which is attached a heavy 36-in. flywheel. A 3-in. crank in this shaft serves to transmit the movement to the rail by

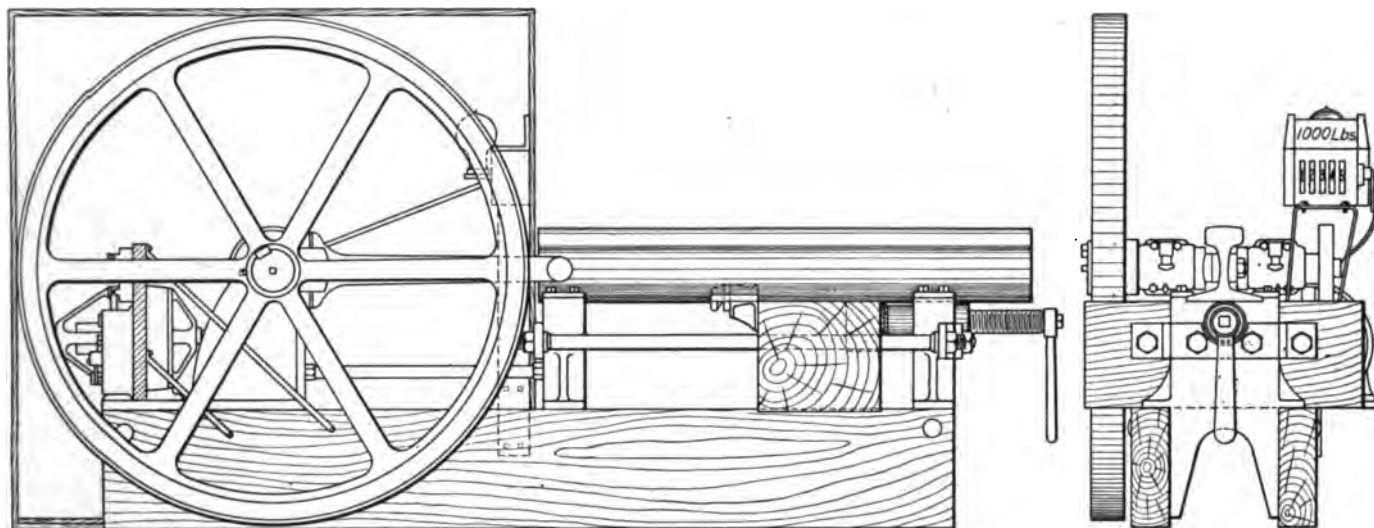

Rail Anchor Testing Machine.

crete averaged about 6 cents per sq. ft. and the materials cost about 6 cents, or a total of 12 cents per sq. ft. Deducting, say, 2 cents for the ballast which would be saved, the net cost of the slabs would be 10 cents per sq. ft., or \$1 per lineal foot of track. On new work \$5,000 per mile would probably suffice to install such slabs, but under main line traffic this figure might be doubled. There are undoubtedly many miles of track where such a capital charge would be justified, both by reduced maintenance expenses and better track.

The slabs at Jamaica were built under the direction of L. V. Morris, chief engineer of the Jamaica improvements, and J. R. Savage, chief engineer of the Long Island Railroad.

**SIBERIAN RAILWAYS.**—The railway department of the Russian ministry of finance which investigates all applications for permission to survey or construct railways by private enterprise, has published a list of new lines, the building of which is considered by the department to be necessary for the normal working of the Siberian Railway system. These new lines (five in all) are chiefly concerned with the development of Western Siberia, but a number of important surveys have also been authorized within European Russia.

means of a crank arm attached near the end of the rail section.

The block which the rail anchor strikes has approximately the same cross section as a tie, but is faced on the edge which receives the blow with a thin plate to prevent damage to the wood. This tie is held in place by a coil spring bearing against the outer casting which supports the rail. A carefully tested spring requiring 1,000 lbs. per inch of compression is used to gage the force which is applied to the anchor at each blow. An electrical contact is provided which flashes an electric light on top of the apparatus when the spring is adjusted to 1 in. of compression. A screw adjustment regulates the amount of compression. The number of blows which an anchor receives in a test is automatically recorded by a counter connected directly to the main shaft. A Vaughan anchor which was put on this machine the first day of the exhibit received 250,000 blows during the week without showing any signs of movement or other damage.

**SPANISH RAILWAY CONCESSION.**—The concession and construction of a 36-mile strategic railway to run from Huelva to Ayamonte through Gibraleon, has been awarded to La Sociedad Espanola de Ferrocarriles Secundarios, petitioner for the railway, for the sum of \$2,684,993. Correspondence should be addressed to Calle de Marques de Cubas, 5, Madrid, Spain.



## A DEVICE FOR CAVING DOWN BANKS AHEAD OF A STEAM SHOVEL.

The accompanying photographs show a device which has been used in a gravel pit at Terrace Park, Ohio, on the Cincinnati division of the Pennsylvania Lines West of Pittsburgh for several months this season to undermine a gravel face about 50 ft. high and to bring down this material at a safe distance ahead of the shovel. This face would stand almost vertical for the upper 30 ft., and if undercut by the shovel dipper, cave down in quantities sufficient to bury the front truck and jack arms of



Attachment in Position on Shovel Dipper.

the shovel and to endanger the workmen in the pit. The first expedient resorted to to avoid this difficulty was the use of long pike poles to undermine the gravel by hand, but this was slow and dangerous.

Finally two pieces of 70 lb. rail 15 ft. long were bent as shown in the photographs. Two ends were bolted together to form a point and the other ends were fastened by "U" bolts to a bar of 1 in. x 4 in. steel which was bent at the ends to fit inside the dipper. These ends of the bar and the sides of the dipper were drilled for 1½ in. bolts by which the device was fastened to the dipper. No other means of fastening was necessary as the rails fitted between the dipper teeth and were held in place.

The device can be applied to the dipper in 5 min., and cave down 50 cars of gravel in 15 or 20 min. by swinging the dipper slowly around and allowing the point to cut a few inches into the gravel at each swing. As this might bring some unusual strain upon the shovel if not carefully used, the device could be modi-



Carving Down a Bank.

fied to provide a hinged joint which would allow its yielding under excessive pressure, this pressure to be controlled by a spring or by small bolts.

This device was used under the direction of F. N. Crowell, division engineer of the Cincinnati division, to whom we are indebted for the above information.

## A NEW QUARRY CAR.

Cars intended for handling stone from a quarry to a crusher should be as low as possible if they are to be loaded by hand and should be designed for automatic dumping at the crusher to save time in unloading and cost of rehandling. It is very difficult to design a car with a body which will dump that is not so high as to be difficult to load by hand unless the capacity of the car is made so small that it is uneconomical. Cars have been designed with a separate body hinged on one side of the underframe which are dumped by an air or electric hoist at the crusher, which engages the side of the car opposite the hinge and lifts the body up so that the load slides into the crusher. Such a car is expensive, however, as it requires practically two underframes. The Orenstein-Arthur Koppel Company, Pittsburgh, Pa., recently designed for the Warren Silica Company, the car shown in the accompanying illustration, which is designed to meet all the requirements of a quarry car at a low



Dumping the Koppel Quarry Car.

cost. The car itself is a very low type double truck flat car with a platform 20 ft. long x 6 ft. 6 in. wide, the level of the floor being only 2 ft. 9 in. above the rail. At the crusher is installed a platform hinged on one side and supported on the other by two pneumatic cylinders. The loaded cars are run one at a time onto this platform, the car is anchored by a catch from the platform which engages a hook on the under side of the car and by admitting air into the platform cylinders, the tippie is lifted on that side so that the car floor assumes an angle of 45 deg., allowing the load to slide off into the crusher. Upon releasing the air from the cylinders the tippie returns to its original position and the train pulls up, bringing another loaded car onto the platform. The operation of this car has proved very satisfactory and the saving in time and labor makes it very economical.

RAILWAYMEN'S FLOWER SHOW.—A flower, fruit and vegetable show held in an arch under Clapham Junction, England, a short time ago consisted entirely of exhibits grown by employees of the London & South Western Railway, residing within a radius of 27 miles from the station, and who are also members of the London & South Western Railway Temperance Union. The first exhibition was held in 1908, when only 73 entries were received. This year there are 500 entries.

# CONCRETE BUILDINGS ON THE LACKAWANNA.

Passenger Stations and Signal Towers of Substantial Construction and Attractive Design Adapted to Local Conditions.

The Delaware, Lackawanna & Western has used concrete very extensively in a wide variety of structures within recent years. During the five years from 1907 to 1911, inclusive, 783,000 cu. yds. of concrete were placed on this road, 267,347 cu. yds. of which entered into structures on the Hopatcong-Slateford cutoff, described in the *Railway Age Gazette* of December 6, 1912,

three signal towers being built entirely of this material on this one cutoff. One of these signal towers, located at Port Morris at the easterly end of the cutoff, is shown in one of the accom-



Standard Concrete Signal Tower at Port Morris, N. J.

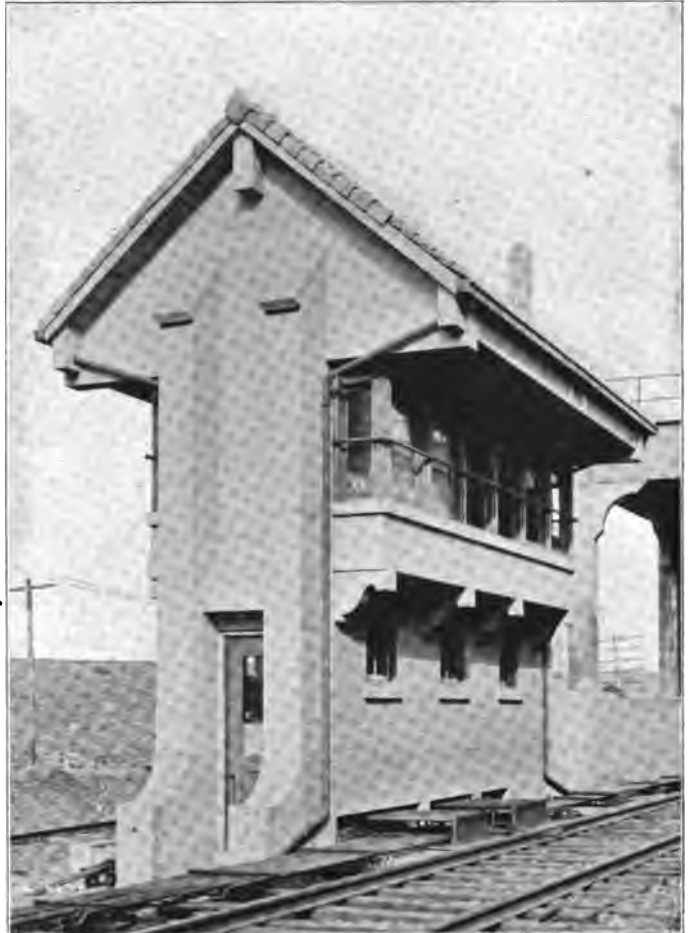

Special Concrete Signal Tower at Kearney Junction, N. J.

and January 3, 1913. On this work concrete was used for every structure from the Pauline Kill viaduct down to the smallest culvert, even the fence posts being made of concrete.

An important application of this concrete work has been its adaptation to buildings, three new stations, a freight house and

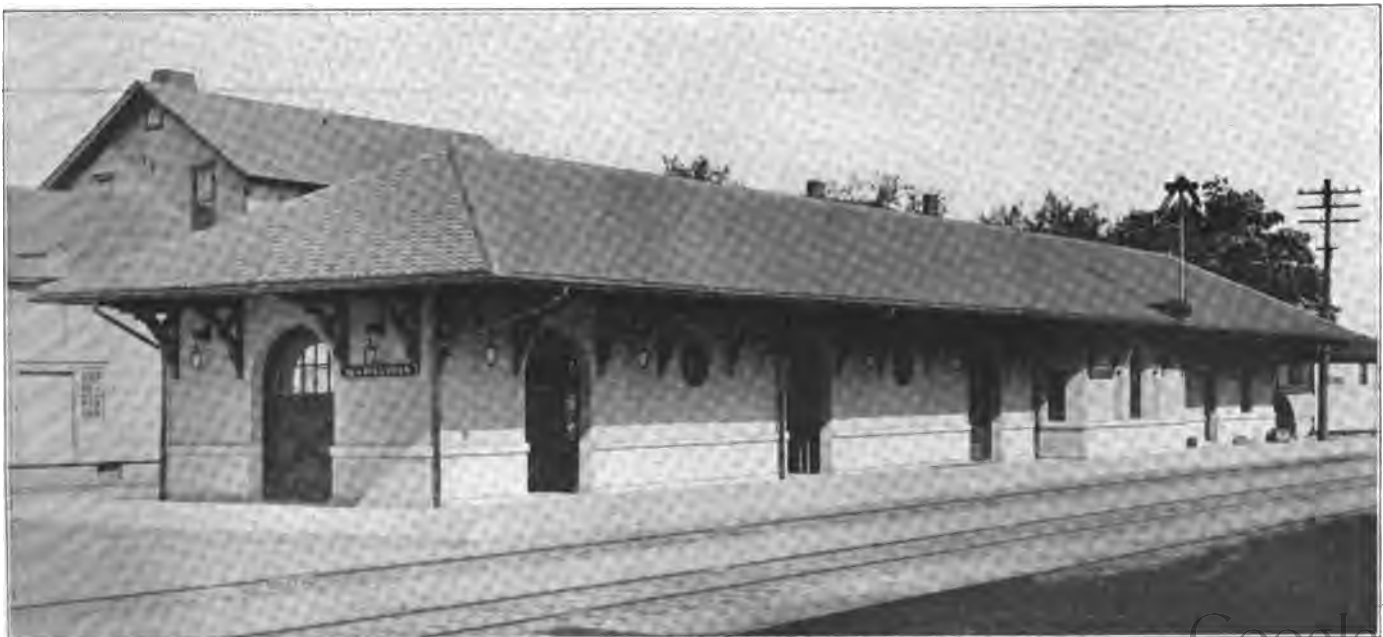

Concrete Station at Marathon, N. Y.

panying photographs. The other two are identical in design, and this same design has also been used at a number of other points on the Lackawanna, varying the length of the building to suit the requirements of the interlocking machine. Up to this time 10 of these towers have been built and this design has

shown was therefore designed 6 ft. wide x 25 ft. 8 in. long on the first story and supported on a foundation box 18 ft. wide x 27 ft. 2 in. long, carried on piles below tide level. The second floor is extended out to a width of 10 ft. 3 in. over the bays, which are supported on brackets cantilevered out from the walls



**Concrete Station at Pocono Summit, N. J.**

come to be considered a standard where concrete signal towers are desired on this road.

There are, however, situations where this design could not be employed, as illustrated by the photograph of the tower at the Pennsylvania overhead crossing near Kearney Junction, N. J. At this point it was necessary to place the tower between tracks and a width of only 6 ft. was permissible at the base. The tower

below. The roof is 18 ft. wide over the eaves and is entirely supported on girders resting on the end buttresses which swell out at the bottom, giving the entire structure an appearance of stability.

Up to the present time seven all concrete stations have been built while four others have been built of solid concrete up to the window sills with stucco above, giving the appearance of a



**Novel Station of Concrete and Cobble Stones at Lake Hopatcong, N. J.**

concrete structure. A number of others have been built of brick with concrete trimmings, which also give very pleasing effects, an instance of this latter design being the Montclair, N. J., station described in the *Railway Age Gazette* of July 4, 1913.

With the stations it has not been possible, nor architecturally

the local conditions and the topography have governed the design and have assisted in the development of unusual and pleasing stations.

At Lake Hopatcong, for instance, a high embankment on the town side of the track was used as a support for an overhead



**Brick Station with Concrete Trimmings at Watessing Ave., N. J., Showing Concrete Cantilevered Canopies.**

desirable to follow the same design to any extent. In some instances where the requirements have been practically the same it has been possible to secure pleasing effects by simply varying the style of design slightly, as can be noted by a comparison of the stations at Marathon and Pocono Summit. At other points

crossing of the tracks. As shown in the photograph, the station itself, which is of cobblestones with concrete trimmings, was located on a high embankment with a stairway descending to the adjacent track and with a concrete structure extending across the tracks to a platform on the opposite side. Elevators



**New Station at Bloomfield, N. J., with Port Cochere on Town Side and Main Station Across the Tracks.**

are provided over each platform for the handling of baggage and express.

At Watsessing avenue on the Mt. Clair branch a different problem was presented. Here the station was located in a thickly built up portion of the city and the company owned limited right of way. At this point in connection with changes in grade the tracks were depressed below the street level. The station was then located directly above the tracks and with a platform in front was supported on reinforced concrete ribs, giving it an arch effect and combining in one the two stations which would otherwise have been necessary. While the station building itself is of brick, an unusual and interesting feature of the construction is that of the concrete canopies over the platform. These canopies were cantilevered out from the retaining walls, eliminating any posts in the platform and were designed so that it was not necessary to increase the dimensions of the retaining wall in any way to provide for this increased load.

The station at Bloomfield, N. J., presented still another problem. Although practically all of the business was done on the eastbound side of the track and it was necessary for the station proper to be placed on that side, the town lay on the opposite side of the track and the people demanded that this building present an attractive appearance from that side. This condition was met by the construction of a small but attractive building on the north side of the track with a porte-cochere, as shown in the photograph, while ticket offices and waiting room were built on the opposite side.

Wherever concrete has been used in either passenger stations or signal towers an effort has been made to produce pleasing color effects and texture of surface by proper selection of materials and by removing the cement from the surface to expose the aggregates to view. This has been accomplished either by the removal of the forms shortly after the concrete has been poured and scrubbing the surface or by tooling it with regulation stone cutter's tools. Where scrubbing has been resorted to this has been done with a liberal application of water and vigorous scrubbing with stiff brooms or wire brushes, depending on the hardness of the surface. Great care must be exercised when using this method to preserve the arises. When stone cutter's tools are used, less care is necessary with the finish of arises, as the concrete is permitted to become considerably harder before the work is started. With this method it is also possible to vary the finish by leaving margins and either rubbing these with concrete stone or lightly bush hammering or tooth chiselling. The surface can either be bull pointed, crandelled or treated in such other manner as best pleases the designer.

This surface treatment has proved highly satisfactory, as it prevents unsightly surface checks, and at the same time gives a pleasing texture and color as well as an honest exposition of the materials of which the building is composed. To further increase the beauty of the structures and to give additional color to the surface, art tiles have been introduced in some instances, as shown in the photographs of Pocono Summit and Bloomfield.

These stations have been built under the general direction of G. J. Ray, chief engineer, and under the direct charge of Frank J. Nies, architect.

**IMPROVEMENTS TO JAPANESE RAILWAY STATIONS.**—The Japanese government railway bureau contemplates expending \$196,000 in improving the Shimonoseki railway station. After the wharf now building is completed the present station will be so extended that the connection between the land and sea transportation depots will be more convenient and up to date. For this \$78,600 will be spent this year in building locomotive round-houses. The balance of the \$196,000 will be spent over a period of four years. The railway station at Wakamatsu will also undergo extensive improvements, at a cost of \$1,485,000, to be extended over a period of four years.

## ACTION OF ALKALI AND SEA WATER ON CEMENTS.

Because of the various conflicting ideas which have been presented from time to time regarding the action of alkali water and sea water on cements, the United States Bureau of Standards has investigated this subject and has published the results of its investigations in bulletin No. 12 by P. H. Bates, chemist; A. J. Phillips, assistant chemist, and Rudolph J. Wig, associate engineer physicist. Since the physical test covered a period of exposure of not to exceed  $3\frac{1}{2}$  years, the following conclusions drawn should be considered somewhat tentative.

Portland cement mortar or concrete, if porous, can be disintegrated by the mechanical forces exerted by the crystallization of almost any salt in its pores, if a sufficient amount of it is permitted to accumulate and a rapid formation of crystals is brought about by drying; and as larger crystals are formed by slow crystallization, there would be obtained the same results on a larger scale, but in greater time if slow drying were had. Porous stone, brick and other structural materials are disintegrated in the same manner. Therefore, in alkali regions where a concentration of salts is possible, a dense non-porous surface is essential.

While in the laboratory a hydraulic cement is readily decomposed if intimately exposed to the chemical action of various sulphate and chloride solutions, field inspection indicates that in service these reactions are much retarded if not entirely suspended in most cases, due probably to the carbonization of the lime of the cement near the surface or the formation of an impervious skin or protective coating by saline deposits.

Properly made Portland cement concrete, when totally immersed, is apparently not subject to decomposition by the chemical action of sea water.

It is not yet possible to state whether the resistance of cements to chemical disintegration by sea water is due to the superficial formation of an impervious skin or coating, which is subsequently assisted by the deposition of shells and moss forming a protective coating, or by the chemical reaction of the sea salts with the cement forming a more stable compound without disintegration of the concrete, or by a combination of both of these phenomena.

Marine construction, in so far as the concrete placed below the surface of the water is concerned, would appear to be a problem of method rather than materials, as the concrete sets and permanently hardens as satisfactorily in sea water as in fresh water or in the atmosphere, if it can be placed in the forms without undue exposure to the sea water while being deposited.

Contrary to the opinion of many, there is no apparent relation between the chemical composition of a cement and the rapidity with which it reacts with sea water when brought into intimate contact.

In the presence of sea water or similar sulphate-chloride solutions, the most soluble element of the cement is the lime. If the lime of the cement is carbonated it is practically insoluble. The quantity of alumina, iron or silica present in the cement does not affect its solubility. The magnesia present in the cement is practically inert.

The change which takes place in sea water when brought into intimate contact with the cement is as follows: The magnesia is precipitated from the sea water in direct proportion to the solubility of the lime of the cement. The sulphates are the most active constituents of the sea water, and are taken up by the cement. Their action is accelerated in the presence of chlorides. No definite sulphate compound was established. The quantity of chlorine and sodium taken up by the cement is so small that no statement can be made as to the existence of any definite chloride or sodium compound formed with the cement.

Metal reinforcement is not subject to corrosion if embedded to a depth of 2 in. or more from the surface of well-made concrete.

# THE ROADMASTERS' ANNUAL CONVENTION.

Report of the Thirty-First Annual Meeting of the Roadmasters' and Maintenance of Way Association, Held at Chicago.

The thirty-first annual convention of the Roadmasters' and Maintenance of Way Association was held at the Auditorium hotel, Chicago, on September 9-12 inclusive. This convention exceeded any previous convention in point of attendance of members, in the more general discussion and in the number and character of the exhibits of the Track Supply Association. The report of the secretary showed 134 new members and a total membership of 750, of whom 239 representing 73 different roads registered. The financial condition was equally good, the treasurer's report showing a balance of \$1,370 in the treasury. One interesting feature of the opening session was the presence of six past presidents on the platform at one time, namely, J. M. Meade (A. T. & S. F.), J. A. Kerwin (Erie), A. E. Hansen (A. T. & S. F.), James Sweeney (C. & E. I.), T. Thompson (A. T. & S. F.) and A. M. Clough (N. Y. C. & H. R.). The officers of the association for the past year were: President, W. Shea, roadmaster, C. M. & St. P., Ottumwa, Iowa; first vice-president, T. F. Donahoe, general roadmaster, B. & O., Pittsburgh, Pa.; second vice-president, W. R. Thompson, roadmaster, C. of G., Macon, Ga.; secretary and treasurer, L. C. Ryan, roadmaster, C. & N. W., Sterling, Ill.

The convention was opened on Tuesday morning with prayer by Rev. W. E. Hopper. Mr. Ross, representing the Mayor, welcomed the convention to Chicago, and W. H. Penfield, assistant to the vice-president of the Chicago, Milwaukee & St. Paul, welcomed the association on behalf of the railways of Chicago. In his opening remarks President Shea called attention to the unusual amount of emergency work which fell to the lot of the roadmasters the past year as a result of the widespread floods last spring. He also urged the co-operation of all members in taking part in the discussion and in assisting in reaching conclusions which would go out as truly representative of this association.

## ACCIDENTS, PERSONAL AND OTHERWISE VIEWED FROM A MAINTENANCE STANDPOINT.

The maintenance of way department of a railroad is, of course, most interested in accidents attributed to defects in maintenance of way standards and roadmasters, most particularly, in accidents resulting from defects in road bed.

From the latest reports obtainable from the Interstate Commerce Commission, the second quarter of 1912, in which only accidents resulting in property losses of over \$150, whether attended by personal injury or otherwise, are included, we find that out of a total of 3,398 accidents reported, only 503 were due to track defects. This we can consider remarkable when we observe that the track and road bed are subjected to never ending and sudden strains and shocks that no other feature of railroad equipment is subject to, and that it is being kept up by the poorest paid, most ignorant class of labor to be found anywhere in a railroad organization.

From this same source and for the same period, we learn that out of a total of 135 killed and 2,934 injured, 24 were killed and 682 injured in accidents arising from track defects.

In view of the special efforts and the large sums of money being spent by railroads to prevent personal injuries and accidents and the attention being given this feature of the subject by men who have specialized in this class of work, the committee does not feel that much has been left undone for it to consider. We are in hearty sympathy with the Safety First movement, and feel that much good can be accomplished.

Referring again to the Interstate Commerce Commission report, we find that out of the 503 accidents attributable to defects of roadway, 45 were attributed to broken rails, 51 to spreading rails, 113 to soft track, 10 to bad ties, 10 to sun kinks, 182 to irregular track, by which we assume is meant bad line, sur-

face or gage, and 92 to miscellaneous causes, including defective switches, frogs, guard rails, crossing plank, etc. During the same three-month period there were 1,145 accidents due to collisions of various kinds, and 1,032 due to defects in equipment. A comparison of these figures should tend to keep our spirits up and cause even greater effort on our part for a better showing.

The elimination of spreading rails, to which 51 accidents were attributed in a three-month period, rests almost entirely in our own hands

Soft track, the most prolific source of accidents charged to roadway, calls for heroic treatment by the man on the ground, and can be attributed in most instances to the lack of, or the poor quality of, ballast furnished.

Bad ties caused 10 accidents. The committee does not feel that present day conditions justify accidents arising from this source. Watchfulness on the part of the roadmaster to see that the foremen exercise good judgment and watchfulness in taking out ties should eliminate this trouble entirely. It is true that a section may be short of help for a season, but we do not feel that any foreman or roadmaster should permit a tie condition that would result in an accident of sufficient importance to be included in this report. We shall not attempt to analyze the 182 accidents classified under irregular track except to impress on our superiors the necessity for sufficient and competent help. If we can succeed in getting good rail, ballast and ties, then it is a question of help. Along this line we might say that more help in a supervisory capacity would result in bigger returns in the long run than would the putting on of additional traveling passenger or freight agents. We do not think that it is fair or good policy to place a roadmaster in charge of a long division with a poor train schedule and expect him to keep in touch with all the details of the work, including coaching and examination of foremen. It is to be deplored that foremen do not get more coaching and more frequent examinations regarding their qualifications.

In 92 cases of accidents classified as miscellaneous we can only recommend eternal watchfulness, good judgment and prompt action. See that switches and all connections are in good condition by frequent inspections, that guard rails are kept as specified and frogs not allowed to pass the limit of safety as regards wear, while at the same time making sure that such material has been used to the fullest limit permissible to a safe track.

Committee: J. R. Coulston, chairman, L. E. & W.; C. J. Coon, N. Y. C. & H. R.; J. J. Hughes, T. R. R. of St. L.; H. Ferguson, G. T.; D. E. Lynch, C. B. & Q.; G. D. Gifford, N. Y. C. & H. R.; F. Button, C. & N. W.; T. H. Gaffney, M. P.

## DISCUSSION.

The discussion divided itself into general comments regarding the safety first movement, including the beneficial effects of co-operation of all departments in preventing injuries to men and in means of removing the causes of accidents referred to in the Interstate Commerce Commission reports as attributable to defects of roadway. In the more general discussion A. M. Clough (N. Y. C. & H. R.) commended that part of the report advocating "safety first rather than safety last" and called attention to the fact that track forces had been carefully trained to avoid injuries in connection with their work long before safety campaigns were started, the track department being well in advance of other departments in this regard. At the present time the track department is called upon to pick up refuse, coal, parts of cars and other material thrown out along the track by employees of the mechanical, transportation and other departments. Instances were cited of drawbars thrown between the tracks and creat-

ing a dangerous condition when they could have been thrown outside the tracks equally as well. Mr. Clough advocated bringing such practices to the attention of the proper officers for the reason that the "Safety First" movement is not at present bringing all the beneficial results possible.

Mr. Burke (C. M. & St. P.) urged co-operation in the promotion of the safety first idea so that instead of throwing all work on the track department each department would endeavor to eliminate its own dangers instead of creating them. At present the section foreman is held to blame for an injury resulting from a drawbar lying along the track even though he may not have been on that portion of his section since the drawbar was thrown out by the train crew.

A. A. Wells (Southern) spoke of the influence of high speed of trains on the number of injuries resulting from derailments and stated that not over 10 per cent. of the personal injuries on his territory were suffered by men at work. T. F. Donahoe (B. & O.) stated that care must be used in relying upon speedometers upon locomotives in checking accidents due to speed, as such records have been found at times to be inaccurate. He cautioned against an engineer watching his speed recorder too closely, as it introduces an element of danger in drawing his attention from the track and signals.

In discussing the means within the power of the track department for reducing accidents due to defects in roadway and structures, several spoke of the importance of seeing that the rail has uniform bearing as a means of preventing broken rails. M. Burke (C. M. & St. P.) advocated that especially in busy terminals only sufficient work be undertaken each day as could be completed and all material picked up before night. He also advocated the use of safety switchstands on all facing point switches not interlocked and urged the most careful inspection of switches that lost motion be not allowed to develop and that they be kept in accurate adjustment. L. C. Ryan (C. & N. W.) said that as one means of promoting safety his road is now buying frogs and guard rails already blocked; also all rail is handled by mechanical unloaders except in cases of emergency. He emphasized the importance of the roadmasters seeing that rules are followed out by their foremen and workmen and urged that they investigate why the rules are frequently disregarded. As a means of securing obedience to rules he advocated paying section foremen a sufficient wage to make their jobs attractive to them, so that they would endeavor to hold them. W. H. Kofmehl (C. M. & St. P.) told of the employment of additional track walkers last winter when encountering considerable difficulty with broken rails. He used night track walkers on many sections, in some instances placing three on a single section. Trains were followed over the line to endeavor to detect the cause of this trouble and it was finally located in two locomotives.

In discussing spread track the consensus of opinion was that with proper materials, supervision and labor, such a condition should not exist. A more liberal use of tieplates on tangents as well as on curves was advocated as a means of preventing this trouble. Some members advocated tieplating opposite the joints where it was impossible to secure sufficient plates to tieplate solidly. A number advocated tieplating, solidly, if at all, to prevent damage to rail due to surface bending, but others did not see the necessity of this if the track was surfaced at the time the plates were applied.

#### CONTRACTING MAINTENANCE WORK.

As this is a new subject it is almost impossible to present figures of the cost of contracting work in the track department under traffic. The committee has not been able to find any road on which this has been given a test.

The St. Louis division of the Big Four has placed stone ballast under track at an average cost of 27 cents per track foot after the stone was unloaded. This was an 8 in. average raise and included tie renewals, dressing and filling. American hobo

laborers used on this work received \$1.75 per day, the foreman \$75 per month, the assistant foreman \$60 per month, and the time keeper \$60 per month. On one division of the New York Central it cost four cents per track foot to lay rails under heavy traffic, not including the unloading of new or picking up of old rail. We have not heard of rail being laid under contract. One road reports that it cost two cents per plate to put on tie plates with foreign labor, including adzing ties, plugging old holes, respiking and gaging. We believe this could be done at less expense if good American labor had been employed.

Your committee has a report on the contracting of the mowing of right of way on one division at a cost of from \$5 to \$20 per mile, where it cost from \$10 to \$30 per mile to do it with section men. This was done under the supervision of the section foreman and with the approval of the supervisor. We also have a report from one road which did standard banking through a level prairie country by hand by section labor at a cost of \$1.50 per track rod. The laborers were foreigners and were paid \$1.60 per day. In the same territory the same kind of work was let by contract at \$1 per track rod. The contractor paid his laborers \$2 per day, and made an average of \$16 per day working 15 men daily. This work was done under the supervision of a section foreman, who took charge both of his regular section work and of this extra contract. We also have a report of tile ditching being done by contract at a saving of from 20 to 30 per cent.

We find that of late years most roads have either been doing all their new track work by contract or under a construction department. In some cases we find this has been satisfactory and in some cases it has not. We are, however, unable to state which proved the cheaper.

It is a fact that contractors pay more money to their men for the same kind of work than the railroads, and they get better men and can do the work cheaper. In addition, a contractor is always equipped with the latest labor saving devices which is not always the case in the track department.

No maintenance work should be contracted without the strictest provision in the contract that it must be approved by the proper department and a competent man provided by the railroad company as an inspector.

Some of the reasons why contract work, so far as it has been tried, is cheaper than that done by section labor may be enumerated:

- a. A contractor can pay his men what they are worth to him.
- b. A contractor always has a following of expert laborers.
- c. A contractor can fortify himself against all conditions, can have his own boarding outfit and can supply his men with better accommodations than a railroad company.
- d. Laborers understand that when they work for a contractor they have to do their part of the work or drop back to less pay or lose their place entirely.
- e. By contracting some of the heavy track work the supervisor or roadmaster would have more time to devote to his regular work, which is an important consideration. It costs much less money to keep track in condition after it has once been brought up to standard than to build it up again after months of neglect and lack of supervision which usually results when the roadmaster is compelled to take charge of new steel or ballast work.

f. The rate of pay for all work done by the companies is based on what we call a standard one rate pay for regular laborers and another rate for extra gang laborers. The poor laborer receives as much as the competent man no matter what the conditions are. The consequence is that we have a gang of men of an inferior class. The roadmaster in charge cannot change their wages, and by the time he has been able to convince the higher officials that he can make a considerable saving by raising wages, the season is too far advanced. The contractor avoids all this, as he is on the ground, in a position to see conditions as they actually are, and in consequence he fixes

his scale of wages according to the supply of laborers and their worth.

Committee: John Barth, chairman, Big Four; James Burke, Erie; T. Hickey, M. C.; Guy Lowers, Erie; P. Madden, C. M. & St. P.; N. McNabb, M. C.; F. E. Crabbs, C. & N. W.

#### DISCUSSION.

Although the committee did not divide its report, President Shea suggested that the discussion be divided in two portions, one the contracting of work not interfering with or affected by train movements, and the other that in which there was more or less interference with traffic. In discussing the contracting of work which is not affected in any way by traffic, A. A. Wells (Southern) has found that the building of fences can be done cheaper by contract and believed that the loading and unloading of ties and the mowing of right of way could also be done cheaper in this way.

H. Van Gorter (C. & N. W.) has contracted the rebuilding of fence for 20 cents per rod. This fence is built with posts 16 ft. apart with one intermediate stay. Old posts were split up for stays, as they were found more satisfactory than the 1 in. by 3 in. hemlock strips generally furnished. He also found that the loading of new ties by contract was cheaper, although he preferred mowing the right of way with company forces, as he secured more satisfactory work.

I. C. Ellison (St. L. I. M. & S.) reported that in contracting the crushing of large quantities of stone for ballast he found that while there was probably no difference in cost between company and contract work, he had difficulty in having the stone crushed to the proper sizes and in keeping out screenings. He also contracted the maintenance of switch lights, but did not recommend this, for he found that although cheaper, the lights were poorly maintained.

A. E. Hansen (A. T. & S. F.) reported building much fence by contract for several years at a cost of from 16 to 20 cents per rod. This year he is building 138 miles of fence with company forces at a cost of 17 cents per rod and is getting much better fence than before, especially with reference to braced corner and end posts. In this work he is paying the same wages usually paid by contractors, which is considerably above the average rate paid by railways, and is getting his pick of the men.

J. P. Corcoran (C. & A.) has contracted the mowing of right of way this year by machine for \$9 per mile. In previous years mowing by hand has cost \$25. He also contracted the cleaning of stockyards three years ago for 28 cents per car, which contract has since been canceled. He is now cleaning these cars with company forces at a cost of 16 cents per car in summer and from 60 to 80 cents per car in winter. A regular gang is assigned to this work and clean from 75 to 100 cars daily. Such time as the gang is not required in cleaning cars is employed in levelling down the bank, the cost of this work not being included in either of the above figures.

J. M. Meade (A. T. & S. F.) stated that tiling is now being generally contracted on the Santa Fe at an average cost of about 16 cents per lineal foot in earth cuts. A vitrified bell end tile generally 6 in. in diameter is laid. He also contracts much bank widening by teams at a cost of from 16 to 20 cents for earth, allowing classification for rock. Bank widening is done in this manner almost exclusively on three divisions.

J. Barth (C. C. C. & St. L.) found that he can mow right of way by contract from 10 to 30 per cent. cheaper than with company forces, by letting this work out to farmers along the line, who take contracts of from one to ten miles to mow during their dull season. Even if the railway company furnished all tools and mowing machines he believed that the work could be contracted cheaper under these conditions.

In discussing the contracting of work affecting the movement of trains, D. Foley (M. C.) stated that he is now laying rail and putting stone ballast under track by contract. In ballasting the railway company furnishes a foreman and all

tools. One gang skeletons the track at a unit price per lineal foot. Following this gang is another one spacing ties and paid by the day. A third gang spends one day putting the stone under track, resurfacing the second, and trimming and lining the track the third day. The company keeps a general inspector on the ground, while the roadmaster makes the final inspection of track before the work is accepted. In laying rail the company distributes its own material and picks up the rail released, while the inspector lays the new rail and breaks the bolts. The contractor lays all switches on his work and does all drilling in connection therewith. The company does not maintain an inspector in connection with the rail laying, but the work is in charge of an experienced foreman who formerly worked for the company. For this reason the quality of work is practically the same, but the duties of the roadmaster are not materially decreased by contract work. Mr. Foley did not believe that the contractor was doing any more work than the company formerly did. The contractor pays the foreman more than that paid by the railway company. In reply to a question Mr. Foley stated that he did not know who would be held responsible in case of an accident.

J. O'Connor (M. St. P. & S. S. M.) tried surfacing track by contract several years ago and found it a failure. Although a competent inspector was employed by the railway company, it was not possible to secure good work. He reported an experience in connection with the contracting and laying of 200 miles of 80-lb. rail several years ago at a contract price considerably below that of company work. The company placed an inspector on the work who kept a record of the actual cost to the contractor. After laying 10 miles at a cost considerably in excess of the contract price and above that of previous company work the contractor gave up the contract. As a result of these experiences he strongly opposed contracting work of this nature.

I. C. Ellison (St. L. I. M. & S.) stated that the Missouri Pacific system has recently completed about 1,000 miles of ballasting by contract. On his division this work was done at a unit price of 80 cents per cu. yd. for loading, unloading and putting gravel under the track. An additional price of 15 cents per tie was paid for all ties renewed. The company placed an inspector, usually a young engineer, on the ground. This method of ballasting was generally unsatisfactory, as it was impossible to get the contractor to tamp the ties satisfactorily, and as he had his own work trains, he frequently delayed traffic. Similar work has recently been done with company forces at a cost slightly below the contract price and with much better work. The contractor paid his foreman \$80 to \$100 per month, and the laborers from \$1.50 to \$2 per day. On similar work the company this year paid foremen \$55 to \$75 and laborers \$1.25 to \$1.50.

#### COMBINED ORGANIZATION OF MAINTENANCE FORCES.

On account of the unnecessary time lost in moving small repair gangs of the signal, bridge and building departments or even the mechanical department over the road it has frequently been advocated that, by raising the standard of our present track forces, much time and money can be saved by the railroads of this country.

For instance, an agent wires he has three or four broken panes of glass to be replaced at his station and gives the dimensions. The glass is forwarded and a man is sent out to make the repairs. His train leaves the terminal at 9 A. M. and arrives at his destination at 11 o'clock. He finds that two of the lights fit, while the other is off-size a slight amount, necessitating his waiting for another glass and very likely, his returning to headquarters for it, and another trip to the town next day.

A conductor sets out a bad order car at some small station and leaves a description of the defects with the operator, who, in turn, notifies the proper department. It very often develops that the information is in error, and a second trip is necessary.

Dozen of similar cases have led many operating men to be



lieve these minor repairs can be taken care of by the men on the ground. Just how, seems to be the only obstacle confronting them. Perhaps most of us will favor the idea of paying one man in a section gang a rate sufficient to secure a good reliable man who can look after such work. Such a man may or may not be required at each section, this depending upon the importance of the station or section.

Another idea advanced by some is to allow each section enough men at the advanced wage to take care of the winter section force. This will be an incentive for the laborers at ordinary wage to try to obtain the steady job and higher rate.

For the officers of such an organization, we necessarily will need well balanced, all around men. Such men, however, should not be hard to secure, especially after a few years of operating with the higher class of section men who will have developed into good foremen and roadmasters.

On account of the necessary requirements, the head of the maintenance department will necessarily be a more lucrative position than that of our present day roadmaster or supervisor and still at the same time the supply will necessarily have to be drawn from the track department.

Some roads have taken steps to combine their maintenance forces, the track and signal forces being the ones most generally considered. It is reported that while some roads favor the combination others do not. One middle west road tried this plan this season and has now abandoned it entirely, as it was found the track condition depreciated while the cost remained as great or greater than before the signals were taken over.

This committee as a whole does not favor any further duties being imposed upon us for fear our roads will not allow the necessary compensations to make it a success.

Committee: Emmett Keough, chairman, C. B. & Q.; A. E. Hansen, A. T. & S. F.; B. C. Dougherty, C. M. & St. P.; P. J. McAndrews, C. & N. W.; F. B. Adams, P. & R.; C. Linehan, C. R. I. & P.; E. J. Boland, I. C.

#### DISCUSSION.

A. A. Wells (Southern) stated that section forces on his division handled minor repairs to pumping plants without difficulty. W. R. Thompson (C. of Ga.) said that on his road the section foremen make repairs to telegraph lines after storms to the extent of putting in poles, etc. The roadmaster has charge of everything on the right of way except steel bridges, as on the Southern. N. McNabb (M. C.) protested against adding more work to the track forces, as he feared that the track would be neglected as a result.

J. P. Corcoran (C. & A.) described the experiment of the Alton with the combining of signal and track maintenance which was tried for two months and recently abandoned. He stated that it was found that the track work was neglected for the signals, as it was difficult to make signal maintainers of the track men, and they had difficulty in locating trouble. The method in use on 300 miles of the main line of the Union Pacific with combined track and signal maintenance and the satisfactory results secured by this method in the three years this has been on trial were described in some detail.

J. Burke (Erie), advocated the combined system on the ground that foremen are secured from the same class of men as maintainers. The wages of section foremen should be increased so as to draw this material from which maintainers are created into the track forces. He believed the tendency to combine forces on the track was in accordance with the same tendency in offices, etc.

J. Buel (Ark. Cent.) described the combined maintenance organizations in effect on his road where the maintenance of bridges, water stations, telegraph lines, buildings, etc., are under the supervision of the roadmaster, and stated this plan worked out satisfactorily.

#### NEW APPLIANCES.

*Manganese Steel.*—There is no question but that the application of manganese steel will prolong the life of frogs and crossings, but in making comparisons it is unfair to lose sight of the

fact that improvements in the design of built up rail crossings and in the rail itself have also been made. Instances have been reported where the results obtained with manganese construction have so far excelled previous records that there seems to be no question as to its superiority over frogs and crossings made of ordinary steel. It has been frequently asserted that where an ordinary frog has a life of from two to five months, a frog with manganese inserts, in the same location, has lasted from one to two years and probably was still in service at that time. Likewise crossings that give all the way from five to fifteen times the service of ordinary rail when made of manganese.

While these tests may apply to rare cases they do not prove that the results will be the same when used in greater quantities, for the failures, as well as the successes, must be taken into account in judging of the true economy of any material. Manganese steel, as generally used in track work, is a cast product and differs from ordinary cast steel in that a small per cent. of manganese is put into the cast steel before molding. By undergoing a heat treatment it is given the tough qualities that make it so desirable in track work.

It is an evident fact that it is very much more difficult to obtain perfect castings where the size is as great as a complete railroad crossing, or even half of the crossing, or where crossing frogs are required in lengths longer than 11 ft. While perfect castings of extreme size and length have, no doubt, been made there is, in our opinion, a very good chance of getting more bad castings than good ones. For manganese crossings and frogs to give the best service the casting must, of course, be perfect. One blow-hole, crack, or flaw may cause a complete failure in a very short time after the casting is put into service.

It is our opinion that if crossings and frogs cast of manganese steel could be made of greater height than our ordinary 80 lb. to 100 lb. "T" rail, they would give better service and not be so liable to crack and break. As this cannot well be done in a great many instances on account of the crossing lying on the portion of the tie that goes under the ordinary "T" rail, we would recommend, to overcome this, that the running rails of the crossing be made heavier.

Poor design and the skimping of weights to reduce cost have been the cause of many failures in crossings. Solid frogs have likewise been unsuccessful when cast with long arms to meet existing rail closures. There is no doubt that we have in manganese steel a metal that adapts itself particularly to this class of work on account of its resistance to wear, its toughness, and the fact that it may be readily cast to the forms of track construction, and we should use this material in such a way that these advantages are not dissipated by improper design and application.

We are inclined to recommend the insert frog in preference to the solid frog or crossing unless a crossing is made of four pieces 11 ft. long. The hard center, or manganese insert type of frog or crossing must, of course, be made up carefully so that the manganese steel part of the frog or crossing that is subjected to the wheel blow and the connection between the manganese casting and the rolled rail are of sufficient strength and permanence to avoid excessive maintenance.

We would recommend that in all cases where manganese steel inserts are used in crossings the running rail be made full size in all cases where it is possible to do so and square at the ends abutting the manganese portion; this in order that in case of rail failures repair gangs can take a piece of rail of the same section, cut it off square at the end, bore the holes in the proper place in the rail, insert the running rail and repair the crossing in a short time, while if the ends of the rail abutting the manganese steel are made with mitered corners and the flanges and heads planed, or ground off, the crossing would have to be taken out of service and scraped or sent back to the frog shop for repairs.

*Tie Plates.*—Tie plates were first adopted for the protection of the tie. However, they are now designed also to resist the

lateral thrust of the wheel flange and to hold the track to gage. We believe that it has been the general experience of roadmasters that smooth bottom tie plates do not present any great resistance to track spreading, because the only added power given to this plate is the holding power of the inside spikes. Preference should be given to such tie plates as do in themselves present resistance to track spreading, if at the same time the bottom design is not such as to work injury to the tie. For this reason, we believe, that a shallow corrugation on the bottom is the best design of a tie plate. This type of tie plate is made in various designs, some with two to four ribs on the bottom running in the direction of the grain of the tie when it is applied, some with two to four ribs running transversely across the bottom or across the grain of the tie, and still others with the corrugations running diagonally across the bottom of the tie plate in both directions. We believe it is the experience of the roadmasters who have used this last-mentioned design of plate, that it best holds the track to gage, as when the plate is seated on the tie it cannot move in any direction. This type of plate is easy to apply, will rapidly seat itself and does not cut or tear the fibers of the tie. Also on account of its form it will to a considerable extent prevent water getting under the tie and rotting it.

Tie plates are being manufactured from malleable iron, wrought iron and steel. In comparing these articles, we believe that wrought iron is the best material. Both wrought iron and malleable iron resist corrosion much better than steel. Wrought iron plates of the proper design cannot be broken, while plates of steel or malleable iron are frequently broken under traffic, the break generally being along the shoulder.

We believe that special attention should be given to the method in which tie plates are rolled. It has been found that wrought iron tie plates which are rolled with the fiber running in the same direction as the rail will break very easily. This also applies to steel tie plates which are rolled in the same manner. Wrought iron and steel tie plates rolled with the fiber running at right angles to the rail do not break in service.

*One Piece Guard Rails.*—Next to a frog in importance both for strength, durability and easy application, we recommend a one piece guard rail with braces, tie plates, and fillers made of manganese steel.

*An Improved Track Drill.*—Perhaps no track appliance that we are of necessity obliged to use can cause more trouble than a poorly constructed or worn out track drill, especially in large yards or where yard construction is going on. We all know what is meant in days gone by to get the butt of the drill out, if one broke that was secured in the socket by a set screw.

We now have an automatic chuck, self-acting track drill with ball bearing gears in which by the movement of a single lever, the drill will run forward or backward. It is a simple, strong and durable machine which we would recommend.

*An Improved Insulated Joint.*—An insulated rail joint with shoulder tie plate is a new feature in track insulation, as the plates that support the rail insulation are in direct contact with the base of the rail as with the regular joint. The fiber sheet between the plate and the rail is being entirely eliminated and is a long step towards making insulated joints easier to maintain.

*Switch Stands.*—The use of automatic safety switch stands with full adjustments, especially for yard use, is to be recommended. A safety automatic switch stand must be automatic under all conditions; that is, it must be automatic when latched and locked, and when operated by a train trailing through at high speed as well as at low speed. It is recommended that switch stands be provided with full adjustments, so that the stand once spiked down need not be moved on the ties.

*Hard Center Spring Rail Frogs.*—A hard center spring rail frog has recently been developed with the rigid wing point and filler all in one piece and with a manganese steel spring wing,

so that with the wear we get with the rigid hard center frog proportionate with what we get from a spring rail frog of the same material, we will have a very durable frog.

*Targets for Switch Stands.*—Targets of the interlocking type in enameled colors are recommended. This type of target cannot become loose or accidentally detached from the switch stand spindle. It slips over the top of the spindle, which is squared so that the target will always register at the proper angle to the track. This type of fastening does not injure the enamel.

*A Steel Car Bunk.*—We believe a solution of the bunk car problem has been found in the all steel bunk recently put on the market. They are built strong, thoroughly braced for double or single deck, are coated with a rust-proof black enamel, and apparently fill a long-felt want. We recommend their use.

Committee: W. H. Kofmehl, chairman, C. M. & St. P.; A. M. Clough, N. Y. C. & H. R.; G. H. Brooks, T. R. R. of St. L.; J. P. Corcoran, C. & A.; Wm. Hazelwood; W. H. Cleveland, A. T. & S. F.; G. M. Green.

#### DISCUSSION.

In the discussion of manganese steel for track work, numerous installations of frogs, crossings and switches were described where the increased first cost has been amply justified. Although an effort was made to draw out information concerning failures of manganese steel and the reasons for them, it was evident that while failures were reported those present knew little about the causes. After considerable discussion the association voted to recommend the use of manganese steel for frogs and crossings wherever the traffic was severe.

That part of the report on tie plates with reference to the design of the bottom of the plate aroused considerable discussion. Two men spoke of instances where track laid with screw spikes spread on curves because of the bottom being smooth, without any ribs. T. Thompson (A. T. & S. F.) referred to difficulty in holding track laid with flat bottom tie plates to gage on curves. On the other hand, President Shea stated that any bottom ridge on a tie plate would shorten the life of the tie, and if plates will not hold track to gage he recommended the use of rail braces.

The consensus of experience was that track laid solidly with tie plates would not require regaging except to take up the wear of the head of the rail, although several instances were recorded where track laid with tie plates had spread.

#### USE OF POWER DRIVEN AND LABOR SAVING APPLIANCES.

*Section Motor Cars.*—The use of section motor cars is considered by the committee an important development toward increase in efficiency. There have been diverging views existing among some railroad men concerning the advisability of installing motor cars on sections and, while their use may not be equally advantageous on all territories, it is evident to the committee, after careful investigation and actual experience in the use of these power driven cars, that there is absolutely no doubt of the economy and advantages in their use.

Where used, these cars have resulted in a substantial saving in track maintenance not only from the fact that a greater territory may be covered by the same number of men formerly employed on the hand car sections, but because experience shows that greater efficiency and longer hours of work are secured; the men reach their work in a condition ready for duty; the service of work trains has been dispensed with, to a great extent, in the distribution of material, moving gangs to and from distant points, and in collecting men quickly in emergency cases.

The power on these cars could also be made use of for such purposes as operating rail saws, drilling machines, putting in screw spikes, etc.

After becoming familiar with the motor car the foremen are

quick to recognize its merits and to give it their best support. Men are more readily secured on sections where these cars are operated. Light repairs to these cars can be readily made by the foremen, and it very rarely becomes necessary to shop the cars for repairs to the motor or parts. Their use may be abused, however, and excessive rate of speed and disregard of trains will sooner or later result in accidents and heavy repair cost. This difficulty is to be avoided by issuing and enforcing stringent rules as to the use and care of the cars.

The committee urges the adoption of motor section cars and recommends their general use, especially on portions of the road where the volume of traffic is not exceptionally heavy.

**Rail Loaders.**—A power driven machine designed to load or unload rails and other heavy material is now very essential and its use has proved its worth on account of its decided saving in labor, satisfactory manner of handling material without damage in an economical manner, and the increase in safety of operation.

Different rail loaders are used, although there appears to be no particular make in universal use and many railroads are still performing such work by hand labor. While on some roads an ordinary light steam derrick or crane is used to some extent, with satisfactory results, there is now on the market and in use by a number of roads, a rail loader, operated by compressed air, which has shown exceptional merit in the rapid handling of rail and other material. It is mounted on a covered flat car and consists of a detachable boom attached to a low mast and guyed to an adjustable "A" frame on each end of the car, which permits of the loading or unloading of two cars at the same time. The hoisting cables which run along the booms are attached to piston rods in the compressed air hoist cylinders which are on the floor of the car and connected with air reservoirs, air for this device being taken from the train line. A loader as above described with a force of nine men will load or unload rails at the rate of four per minute.

**Stone Ballast Plow.**—This machine, which is used for the purpose of loosening stone ballast in track centers preparatory to cleaning, will do the work of several hundred men with picks. It is permanently attached to a flat car and has rigid horizontal arms which may be extended from one end of the tie to the center line by air pressure. On these arms are carried plows which consist of tool steel spuds about 12 in. long, the section at the top being 3 in. across and 6 in. lengthwise with the track. The arms are raised and lowered by air pressure and are driven into the road bed to a depth of several inches below the bottom of the tie if desired. The plow is moved at a speed of from five to six miles per hour.

**Other Operations Using Compressed Air for Power.**—Where there is a supply of compressed air at hand it has been found to be very satisfactory and economical to use it in cleaning the iron work from bridges, also in cleaning the bridge seats. The ordinary pressure hose is used with a nozzle and thumb valve. By this method one man can clean a bridge as quickly and more satisfactorily than five or six men with brooms and brushes.

Pneumatic drills have been used to bore rails in track and around interlocking plants, and it has been found that two men in two days will accomplish as much of this work as four men with hand drills in four days.

**Miscellaneous.**—In applying bolts when renewing rail in main tracks, considerable time is gained by using short wrenches, about 8 inches long, by which a nut can be rapidly screwed up. These nuts are later tightened by men who follow with the long wrenches.

On stone ballast territory, canvas aprons are sometimes a part of the work train equipment and are used to cover the stone ballast shoulder when loading dirt from the ditch.

In distributing coal to stations a sectional chute about 24 ft. long, when extended, is very practical, and a considerable saving in labor over carrying coal in bags.

Committee: H. E. Astley, chairman, N. Y. N. H. & H.; Coleman King, L. I.; J. H. Angier, N. Y. C.; Z. B. Couch, L. & N.;

J. W. Fletcher, Jr., Chi. & N. W.; J. W. Powers, N. Y. C.; Robert Faries, Penn.

#### DISCUSSION.

Owing to lack of time this report was accepted without discussion.

#### BANQUET.

A banquet was tendered the roadmasters by the Track Supply Association on Thursday evening, about 300 attending. A. H. Weston, president of the Track Supply Association, acted as toastmaster.

W. L. Park, vice-president of the Illinois Central, addressed the men and laid special emphasis on the responsibility of the individual employees to the railways. While the cost of living is going up by leaps and bounds, we have the lowest freight rates of any country, and these rates are still being lowered. On the other hand, the cost of materials is rising. The roads in this country are being bettered in condition, but at a rapidly increasing expense."

Referring to the freak legislation, as he termed it, Mr. Park emphasized the importance of employees giving the railways their loyal support and co-operation, and stated that if each employee would make two friends for the railway each year railway baiting would soon stop. "The practical railroad men know the order in which there should come about a bettering of the physical conditions. If a wreck occurs through a collision the would-be regulators immediately propose a panacea in the abolishment of wooden cars, although they do not know as yet to what extent steel cars are preferable. If a flagman fails to do his duty, automatic signals are to be forced by law regardless of the fact that the road may not be paying dividends, and a maudlin public sentiment excuses the real culprit.

"If the block signals fail to stop an engine there is a hue and cry for automatic control, although such a device has not yet been invented and is considered by practical railroad men to be impossible, as the responsibility cannot be taken away from the engineer.

"Millions of dollars are being paid out in refinements of freight car equipment, such as a nice adjustment of the height of cars, wrought iron brake wheels that are never used, instead of cast iron, ladders on each corner of a car, and many other innovations that do not go very far to prevent personal injury. This money wasted in many directions through the interference of those who know little about the actual conditions on the railroads would provide real safety if the managers were permitted to spend it in the direction it should properly go.

"A railroad manager would be criminal to put money in expensive track elevation, separation of highway crossings, or steel cars if the railroad had only sand ballast, wooden bridges, inadequate drainage and protection against washouts, landslides, etc., items which are well known to practical operating officials as being those which should receive first consideration.

"The Pennsylvania railroad company has 75,492 shareholders, 48 per cent. of whom are women, and 12,634 own less than ten shares, the average holding being 120 shares. The New York Central lines have 20,944 shareholders, of whom 12,881 own less than 100 shares. The Santa Fe lists 32,000 shareholders, and the average stockholder owns eighty-nine shares. The Baltimore & Ohio stock is held by 10,436 individuals, 9,160 of whom own less than 100 shares. The Chicago & Northwestern is owned by 9,000 stockholders, 5,000 of whom own less than 100 shares. The Illinois Central has 10,196 stockholders—8,313 own less than 100 shares and 2,814 own less than ten shares.

"It is absurd to expect these stockholders to go without their dividends indefinitely to provide for betterment of the railroads from which they will not be permitted to obtain any additional returns. The greater part of them are poor people, who live on the income from their investment."

## ECONOMIES OF TRACK LABOR.

H. R. Safford, chief engineer of the Grand Trunk, addressed the men on The Economics of Track Labor. He said in part as follows: The problems you face today in the work of building and maintaining track, roadway and structures are nearly all economic ones or at least have an economic side. We are and have been for the past ten years approaching a clearer comprehension of the fact that many of the problems which we have been trying to solve as simple ones of construction and maintenance are equally economic in nature. Labor, which constitutes such a great element in the construction and maintenance of track, is a commodity of fluctuating value and with no standard of efficiency. Its instability, as far as the laborer is concerned, is the great difficulty, and as it has not yet been demonstrated that a premium should be paid for skilled labor, the price paid follows the economic law of supply and demand, and it is purchased as coal, lumber, vegetables, etc., are purchased, that is to say, the price paid should not exceed that for which it can be obtained. I refer, of course, to the laborer only, not to foremen.

The economics of track labor may be generally divided as follows: 1. The study of organization as applied to the track department. 2. The study of the problems surrounding the employment and working conditions of track foremen and laborers. 3. The study of a means to determine efficiency. 4. The study of a means for raising such efficiency. 5. The study of a means for measuring and comparing conditions, so as to establish a method for economically and fairly regulating and making appropriations for expenditures.

I believe in speaking of organization we may truly say that as applied to railroad operation our methods are too traditional in many ways. They are methods which are not only time honored but in many instances time worn. Perhaps no general changes are proper, but can we speak positively as to this? I maintain that we cannot answer those questions positively, because we do not know. Can we say that some of our trouble now experienced is because the organization method is not proper and that they can be eliminated by changing it? We certainly cannot, but if the present method is the best we should know it as the result of the most careful study, as it is, certainly worth something to have this determined. And, if such is not the case, what improvement is recommended?

What are the conditions which should be considered? One is the proper length of section. What are the limiting things to establish this length? I doubt if any good reason can be shown for our present practice beyond the fact that our experience with inherited plans seems to show that on a single track railroad of moderate length, six miles would appear to be proper, but there we end. We know little about the relative economy of increasing the number of sections and increasing the supervision thereby, or reducing the section and introducing such things as motor cars to reduce the delay by running over long stretches. And there is only one way to work it out, and that is by experiment. I think this one feature, namely, the use of motor cars, is simply a matter of economics. If it is economical it must first be shown that the interest, depreciation and cost of operation of such a car is less than the time lost in pumping over the road, plus the reduced efficiency caused by such effort.

I heard a very prominent railroad executive say a few years ago that the modern or future section organization would be a technical man as foreman, a gang of 15 men, a 10-mile section and a motor car. I have never thought that the outline was correct, especially the first specification—that of the technical man—because track work is not technical in most of its features, but I do not attempt to say that the balance of the specifications are not correct and there may be much merit in them.

One thing that leads to the suggestion of maintaining long sections is the growing difficulty of obtaining foremen, but this at once opens up another feature mentioned as one of

the distinct classes of economics, namely, working conditions and efficiency. There cannot be any doubt about one fact, and, that is, that foremen will not be hard to get if the position is interesting and attractive, because from the union of those two things springs contentment.

Let us stop to consider what goes to make the position interesting and attractive. One of course is compensation, and this opens up a vast argument, which volumes cannot adjust. Compensation in itself, as measured in standards of mediums of exchange, is not all that a man wants. He does want such compensation as enables him to live comfortably and perform his obligations to his family and lay by something, yet, the fact is that there is a certain market value upon the price of service of any kind, which generally follows the law of supply and demand, another economic principle which must not be lost sight of.

Another thing to make the position attractive is pleasant environment. This means comfortable living conditions for himself and family, educational advantages for his children, proper discipline and treatment, and above all the feeling that he is being aided to become a stronger man intellectually, and that there is a future for him as a reward for such effort to obtain intellectual advancement and enlarged experience.

The section foreman, as a class, is most responsive to such interest shown by his superior, and my experience has been that he wants to advance and will bend every effort to that end if given any encouragement. He should be made to feel that his position is an important one and while not equal to that of his roadmaster, yet, it is a means of rising to his superior's position. These are the things which produce contentment. The observance of them is not offset by doubly increasing his salary, for money cannot buy contentment.

We hear constantly the cry that we are not making section foremen. In years past we did not have to make them, and so we did not learn how to do it. They made themselves for us. Now we are confronted with a vastly different situation, and we will have to make them or we will not have any. And the time has come to make a very vigorous effort along this line. I believe the apprentice system is the only feasible means, but it has fallen down in many instances, because the apprentices were not willing to wait for advancement. The apprentice plan is for the purpose of preparing men for advancement and to make it successful two essential things must be done. 1. There must be a little higher rate of compensation paid than to laborers, so that they will not be attracted away by offers of increased compensation from employers needing temporary service, and 2. The proportion of apprentices must be limited to such a number as will insure reasonably early advancement, otherwise the individual will become impatient.

Now, having established a means for preparing men for foremen the work of education must continue with them. There must be a very systematic method for instruction along the lines of their work. I have always thought that the best plan was by frequent conferences and free discussion. Conference has the one great advantage over individual study that the viewpoint of the other man becomes known and often leads to a wider range of thought.

I do not for one moment minimize the great benefit to be derived from the educational bureau established by many railroads wherein a systematic course of study is outlined, for I think it is an excellent plan, but I do think that such a system is not sufficient in itself. It needs the stimulus of conference and discussion, for let us remember that the section foreman works hard physically and he is not by training a student, and it is hard for him to study alone to advantage.

Another thing of moment is that section foremen have very limited opportunity to discuss their work with others of their own class, which is one of the greatest aids from an educational standpoint. As a rule they are isolated from their fellow foremen and their only education or instruction comes from their supervisors or roadmaster, and it comes possibly

in very good shape, but too often in the form of notes of direction and not by a systematic plan of education, in which time is taken to analyze or discuss the matter very thoroughly.

The best method to obtain this is to call frequent meetings of all foremen of a district at a supervisor's headquarters, and at such meetings standards, expense, plans for work, etc., should be discussed. There is no better way to raise the standard of efficiency, and I know from experience that such practice will stimulate a great deal of interest on the part of the section foreman in his work.

The true measure of a man's efficiency is a thing not yet worked out upon mathematical lines. This is because conditions which affect track expense, particularly labor, are so different that it is a difficult problem. The only way that this can be done is to develop units of cost from the most elaborate tests so that a definite measure can be applied. One always hears the answer to such suggestion that such means involve clerical expense too high for the results obtained. In my opinion such reply is not always correct. The maintenance of way officer is obliged to measure the efficiency of his force by units of cost. If it is worth anything to know what the relative results of different sections or districts should be, it is worth something to have a system to obtain it correctly.

This brings up another feature, namely, equating track values. What does each particular condition of track mean in dollars and cents from a standpoint of cost to maintain? In other words, what does it mean in cost to maintain different classes of track, taking into consideration all of the things that affect expense? That is to say, what does curvature, kind of ballast, character of rail, quantity of traffic, etc., mean in dollars and cents?

One of the greatest difficulties met today by the man charged with the apportionment of expenditures is how to divide such expenditures equitably. The time has come when it is necessary to work on such a fine margin in apportioning money for maintenance that the most careful consideration is needed, and the judgment of the individual cannot always be relied upon to form the correct basis for such distribution. This is quite a difficult problem, for the factors which comprise it are: Speed of trains, weight of engines, quantity of traffic, alinement, character and age of rail, character of ballast, character of ties, character of roadbed, length of side tracks, width of right of way, climatic condition, etc. The relative value of those things is not known and yet it should be known by the supervisor, engineer, maintenance of way, and general officer.

There is only one way to work it out and that is by experiment, that is, by taking sections of track, representing various conditions as above outlined, and for a period of, say, one year keep a very careful record of the cost data. And, after such data is obtained, it will be possible to distribute money more easily and to hold up to the foreman the mark he can be expected to reach, and I know of no more important thing to work out. It will establish automatically a standard to which you can expect a man to attain without any allowances for conditions.

Another very pertinent and interesting question incident to this subject is the matter of extending the scope of duties of a section foreman to include to a limited extent certain work now handled by other classes of labor with a view to saving expenditure and time. To what extent such an idea can be carried out is not yet accepted; the possibilities are far from being known, but the fact remains that the idea warrants the most careful study. It may require greater ability and differently trained men to occupy the position of section foreman, but this alleged objection is not one which should kill the suggestion. The development of the idea and the application of the principle must be very conservative and gradual.

There is one more important feature connected with the economics of track labor, and that is planning work and executing it to the best advantage regarding season, labor, climate, etc. The demand for systematic planning of expenditure is greater than ever. I never feel like criticizing the manager when I hear an order go out for a certain reduction, even when it badly disorganizes everything, for I know that as a general proposition the executive has not been given very accurate information as to what such an action means. I know that very few, if any, men have taken the time to sit down and determine either by theoretical analysis or experiment just what disorganization means; what it means to do work in the least advantageous season of the year, what it means to work non-systematically.

We too often know that the wrong practice is being followed, and we say so, but to the man who must stand between you and the stockholder must be given some actual figures to support your views. If you are on a railroad which, owing to financial difficulties, prevents you from putting on your summer force until late in the season, demonstrate by the results on an experimental section what you can save by putting on your forces early and taking them off early, and I warrant that you will have no difficulty in carrying out the correct policy. Even if you cannot get all the money you want, you will get more for your money if you follow the right method.

A disturbing influence as far as track work is concerned is the fact that the fiscal year ends June 30, right in the midst of the busy season. It should end December 31, when forces are light and the least work is in progress, because it is perfectly natural for the end of the year to occasionally cause some disturbance in working plans. Stockholders are watching the net and do not of course understand the physical conditions. A strong effort should be made to have the fiscal year end December 31, and the reasons are those which concern your particular work and I believe convincing arguments can be made showing the advantages of changing the practice, which would greatly influence those who have the power to regulate this.

The field for study along all these lines is unlimited and must be quickly opened up, for the constant reduction in net earnings is causing enforced conservatism in apportioning track expense, and the public is analyzing failures of track structure more minutely all the time. Our managements expect us to determine the proper economic practice, to determine the capacity of the various features of the track structure and to be able to clearly prove the correctness of such practice and design as being entirely safe.

#### OTHER SPEAKERS.

James Burke, superintendent of roadway, bridges and buildings of the Erie, emphasized the fact that modern efficiency demands the best efforts of track men and track supply men alike in the developing and maintaining of track to carry the heavy traffic of the modern railroad. Track men of today are assuming a more important position than a few years ago because of this condition, and the position of foreman requires more intelligence than in previous years. Better material is likewise required for the same reason.

Other speakers were President William Shea, of the Roadmasters' Association; Past President A. M. Clough, and Secretary W. C. Kidd, of the Track Supply Association.

#### BUSINESS SESSION.

At the annual business meeting held on Friday morning Chicago was selected as the location for the next convention to open on the second Tuesday in September, 1914. The following officers were elected for the ensuing year: President, T. F. Donahoe, general supervisor of road, B. & O., Pittsburgh, Pa.; first vice-president, C. H. Gruver, road master, C. R. I. & P., Albert Lea, Minn.; second vice-president, B. C. Dougherty, roadmaster, C. M. & St. P., Beloit, Wis.; secre-

tary-treasurer, L. C. Ryan, roadmaster, C. & N. W., Sterling, Ill. Member of Executive Committee: P. J. McAndrews, roadmaster, C. & W., Belle Plaine, Iowa.

**TRACK SUPPLY ASSOCIATION.**

The exhibit of track supplies and devices conducted by the Track Supply Association occupied all available space in the corridor of the hotel adjacent to the convention hall and included a large variety of appliances manufactured by over 50 companies.

The meeting of the Supply Association was held on Thursday morning, September 11. The officers of the association for the past year were: President, A. H. Weston, Lackawanna Steel Company; vice-president, Walter H. Allen, Pennsylvania Steel Company; secretary-treasurer, W. C. Kidd, Ramapo Iron Works. The officers elected for the coming year are: President, Walter H. Allen, Pennsylvania Steel Company; vice-president, E. M. Fisher, Fairbanks, Morse & Company; secretary-treasurer, W. C. Kidd, Ramapo Iron Works, and members of the Executive Committee, Henry Fisher, Verona Tool Works, and L. P. Shanahan, American Steel and Wire Company.

**EXHIBITS.**

- Ajax Forge Company, Chicago.—Ajax manganese guard rails. Represented by F. B. Bradley, H. G. Elfborg and H. C. Hutchins.
- American Hoist & Derrick Company, St. Paul, Minn.—Transparency views of the American railroad ditcher. Represented by Edward Coleman and C. C. Austin.
- American Steel & Wire Company, Chicago.—American railroad-fencing and galvanized steel fence posts. Represented by J. W. Collins, L. P. Shanahan, C. W. Boon and B. B. Ayers.
- American Valve & Meter Company, The, Cincinnati, Ohio.—Economy switch and interlocking stands, safety locks and quick-repair switch stands. Represented by J. P. McGarry and F. C. Anderson.
- Associated Manufacturers' Company, Waterloo, Iowa.—Jerry Boy hand car engine with special features of magneto and reversing device. Represented by A. H. Ambrose.
- Beaver Dam Malleable Iron Company, The, Beaver Dam, Wis.—Malleable iron tie plates and rail braces. Represented by B. P. Lamoreux and Frank B. Bell.
- Barr, James C., Boston, Mass.—Brown rail loader. Represented by James C. Barr and Robert H. Anthony.
- Blessing, Louis, Jackson, Mich.—Reinforced concrete tie, rail clamps and continuous rail joint. Represented by Louis Blessing.
- Carnegie Steel Company, Pittsburgh, Pa.—Automatic stereopticon showing pictures of steel tie track; section of steel tie with new fastening, and Duquesne bar. Represented by M. M. Hench and Robert Coe.
- Chicago Pneumatic Tool Company, Chicago.—Rockford motor cars. Represented by J. C. Camel and J. L. Canby.
- Commercial Acetylene Railway Light & Signal Company, New York City.—Flashing and steady acetylene signal lights. Represented by H. G. Doran.
- Crerar, Adams & Company, Chicago.—Calumet drills, Eureka bonding drills, new track shovel of vanadium steel, whitewashing machine, snow brooms, and Milburn lights for wrecking cars. Represented by Russell Wallace, G. D. Bassett, J. A. Martin and C. O. Swift.
- Economy Separable Switch Point Company, Louisville, Ky.—Economy switch points and claw bars. Represented by W. M. Mitchell, J. A. Shoulty, John R. Long, J. R. Montgomery and L. C. Ferguson.
- Elliot Frog & Switch Company, East St. Louis, Ill.—Switch stands. Represented by H. Elliott and W. J. Fairback.
- Fairmont Machine Company, Fairmont, Minn.—No. 1 motor car, roadmasters' inspection car and 5-h.p. engine for section cars. Represented by F. E. Wade and H. E. Woolery.
- Fairbanks, Morse & Company, Chicago.—Motor cars. Represented by A. A. Taylor, F. N. Whitesell, E. M. Fisher, J. T. Gratiot, D. J. Higgins, L. H. Mathews, E. E. Pendray, E. C. Golloday, F. V. Roy and L. Norvell.
- Frictionless Rail, The, Boston, Mass. Represented by F. A. Barbey, S. W. Simonds and G. H. Bryant.
- Haggard & Marousson, Chicago.—"Tiger" steel bunk. Represented by Henry H. Marousson and E. A. Sammons.
- Hall Switch & Signal Company, New York City.—Signal appliances. Represented by W. J. Gillingham, Jr.
- Hayes Track Appliance Company, Richmond, Ind.—Hayes details. Represented by E. L. Ruby and S. W. Wallace.
- Hobart-Allfree Company, The, Chicago.—Derailers and car replacers. Represented by W. H. England, E. H. Allfree and F. R. Cooper.
- Joyce-Cridland Company, The, Dayton, Ohio.—Track and bridge jacks. Represented by C. D. Derby and W. I. Crock.
- Kelly-Derby Company, Chicago.—Rail braces, combination tie and shimming brace and rail relaying machine. Represented by C. W. Kelly, R. E. Derby and W. B. Holcomb.
- Keystone Grinder & Mfg. Company, Pittsburgh, Pa.—Tool grinders. Represented by Wm. L. Munk.
- Lackawanna Steel Company, Buffalo, N. Y.—Tie plates and rail joints. Represented by A. H. Weston.
- M. C. B. Co., The, Chicago.—Dinklage creep check and Conley frogs. Represented by W. E. Marvel, F. A. Buckley and C. R. Westcott.
- Mudge & Company, Chicago.—Mudge-Adams inspection car and engine equipment for section cars, also railway specialty class FS section car. Represented by R. M. Smith, R. D. Sinclair, J. I. Winchell and G. W. Bender.
- National Lock Washer Co., The, Newark, N. J.—Nut locks. Represented by John D. Seymour and Alvin T. Thompson.

- National Malleable Castings Company, The, Cleveland, Ohio.—Tie plates, bridge washers, rail braces, anchors, combination rail tie plate, rail brace, and rail anti-creepers. Represented by James L. Pray, J. J. Byers, C. H. McCrea, C. L. Johnson and W. B. Bellman.
- Northwestern Motor Company, Eau Claire, Wis.—Casey-Jones hand car engines. Represented by K. Rosholt and R. R. Rosholt.
- P. & M. Company, The, Chicago.—Rail anchors and anti-creeping tie plates. Represented by F. A. Preston, Philip W. Moore, D. T. Halberg, A. R. Sutter, L. S. Walker, J. W. Dodge, Jr., and George E. Johnson.
- Positive Nut Lock & Tie Company, Grand Rapids, Mich.—Positive nut lock. Represented by M. M. Goble.
- Positive Rail Anchor Company, Louisville, Ky.—Positive rail anchors, and Betts anti-creep tie plate. Represented by W. M. Mitchell, J. A. Shoulty, John R. Long, J. R. Montgomery and L. C. Ferguson.
- Q & C Company, The, New York City.—Vaughan rail anchors, Bonzano rail joints, rolled steel step joints, guard rail clamps, rail anchor testing machine in operation. Represented by A. E. Stokes, J. A. Bodkin, C. D. Woolworth and J. V. Westcott.
- Pennsylvania Steel Company, Steelton, Pa.—Model 60-A shearable pin new Century switch stand, Model 50-A new Century switch stand rolled "never-slip" switch plate, Mayari steel, heat treated, "never-turn" bolts. Represented by Walter H. Allen, Fred H. Ogden, Geo. K. Reel and J. Drew Allen.
- Rail Joint Company, The, New York City.—Rail joints. Represented by H. C. Holloway, W. E. Clark, Chas. Jenkinson, Fred A. Poor, W. S. Boyce, R. W. Smith and E. A. Condit, Jr.
- Railroad Supply Company, Chicago.—Wolhopter shoulder flange. Represented by E. H. Bell, H. J. Van Nostrand, M. J. Cumerford, F. C. Webb and A. H. Smith.
- Ramapo Iron Works, Hillburn, N. Y.—Switch stands, manganese switch points, rolled steel shoulder friction plate, and guard rail clamps. Represented by W. C. Kidd, T. E. Akers and Arthur Germunder.
- Sellers Manufacturing Company, Chicago.—Tie plates. Represented by J. M. Sellers, R. A. Van Houten and G. M. Hogan.
- Southern Railway Supply Company, St. Louis, Mo.—Saunders' car stopper. Represented by M. E. Townner, W. D. Achuff and D. R. Saunders.
- Templeton-Kenly & Company, Chicago.—Simplex jacks. Represented by W. B. Templeton, A. E. Barron and A. C. Lewis.
- U. S. Wind Engine & Pump Company, Batavia, Ill.—Switch stands and semaphores. Represented by C. E. Ward and L. E. Welcott.
- Union Switch & Signal Company, The, Swissvale, Pa.—Keystone insulated rail joints. Represented by J. J. Cozzens and J. D. Roett.
- Verona Tool Works, Pittsburgh, Pa.—Complete set of track tools. Represented by Henry Fisher, Rex Gay and E. Woodings.
- Whall, C. H., & Company, Boston, Mass.—Whall's special railroad fiber. Represented by C. H. Whall.
- William Wharton, Jr., & Company, Inc., Philadelphia, Pa.—Manganese steel guard rail and brace, combination rail tie plates, guard rail clamp, anti-creep, switch stand, pictures of important installations. Represented by R. C. McCloy, G. R. Lyman, J. R. Bolgiano and F. R. Schaefer.

**A NARROW GAGE INSPECTION MOTOR CAR.**

A narrow gage gasolene inspection car has been recently built for use on the East Broad Top Railroad & Coal Company in Pennsylvania, this line being of 3 ft. gage. In building this car it was necessary for the crossarms to be 1 ft. 8½ in. shorter than those of the standard gage car. The problem which then confronted the designer was to secure the proper distribution of

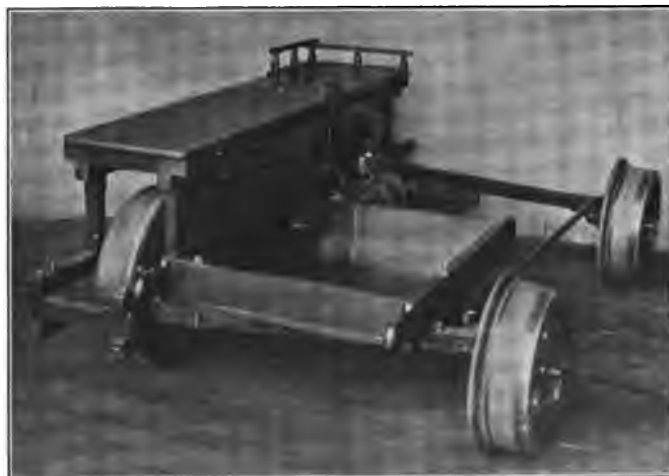

**Narrow Gage Gasolene Inspection Car.**

weight of the car to secure the greatest tractive power, and at the same time to maintain the equilibrium of the car when in operation. This car was built by Mudge & Co., Chicago, and is of the same general construction as the Mudge-Adams cars used on standard gage roads. The car is equipped with a 2-cycle air cooled, 4 h. p. single cylinder motor direct connected to the rear wheel.

## A GERMAN EXPERIMENTAL RAILROAD.

As mentioned in an article by B. B. Milner on "A Maintenance Department Testing Plant" in the *Railway Age Gazette* of August 15, the Prussian State Railways have maintained for some time an experimental track about 2.2 miles from Oranienburg, a city of 13,000 inhabitants about 18 miles from Berlin. On account of the importance of the suggestion made by Mr. Milner that a similar experimental station should be established in this country for determining the stresses in track and the testing of all kinds of track material, the following description, which is abstracted from a translation of an article in "Annalen fur Gewerbe und Bauwesen," will be of interest.

The plan of the experimental road is shown in the accompanying drawing. The track is laid on a plot of ground almost entirely level, the soil being hard, homogeneous sand which furnishes an excellent foundation for the roadbed. The track is elliptical in form, the curves at the ends having a radius of 652.6 ft. (about 8 deg. 47 min.) and being joined together by two straight stretches each about 652.6 ft. long. The total track length is 5,764.4 ft. The elliptical shape and comparatively short length was chosen because it allows the testing train to cover the entire track 28 times per hour at the normal velocity, which is 31 miles per hour. The sharp curvature which was necessary on so short a track is somewhat of a disadvantage, as this is rarely used on main lines, and on account of the limitations which it imposes on the speeds, makes impossible the observation of phenomena at velocities higher than about 37 miles per hour. It is also necessary to use a guard rail along the inside rails of the track so that the common conditions existing on curves of moderate degree cannot be observed. These disadvantages were considered of minor importance, however, in comparison with the requirement of high traffic frequency. The curves are superelevated for the 31 mile velocity, this elevation amounting to 4.9 in. Various rates of attaining this maximum elevation are tried at the ends of the curves in order to compare the effect of such variations on the wear of the track and equipment.

Such a road can, of course, be operated only with electricity to make possible the control of the train from an outside point. Until April, 1908, two locomotives that had been used experimentally on one of the government lines were operated over the experimental track. Then a locomotive weighing 60 tons was used, pulling a freight car as a trailer, the total weight of car and locomotive being about 250 tons. By using the third motor of the locomotive this weight could be increased to 375 tons. This locomotive was operated 20 hours a day, from 11 a. m. until 7 a. m. of the next day, with two brief intermissions for inspection. It made from 450 to 500 round trips over the track, a total distance of about 512 miles. It has been found possible to operate the locomotive about 250 days a year, making a total of about 117,500 round trips. This locomotive has recently been



Electric Locomotive Used on German Test Track.

replaced by another, which is shown in the accompanying photograph. The power used for operating these locomotives is secured from the Oranienburg City Electric Works, about 2.3 miles away, the current being transmitted at 6,000 volts, 25 cycle, single phase, a. c. and stepped down in the locomotive to 400-500 volts.

Up to the year 1909, the track was divided into four sections in each of which a different type of track construction was laid. On each section oak, red beech, pine and steel ties were laid, and throughout the length of the track various kinds of stone

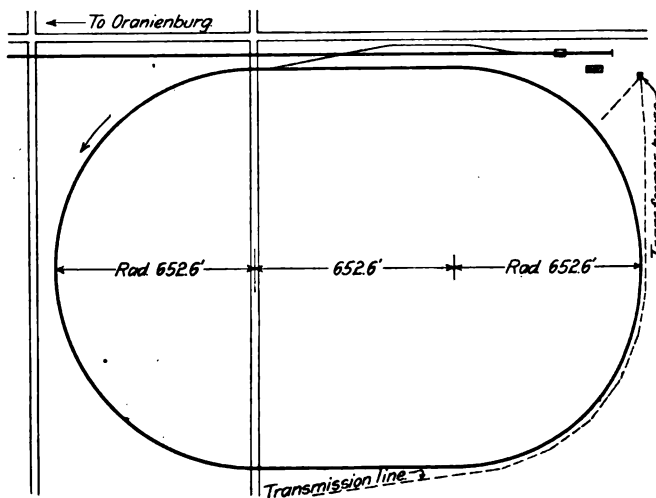

Plan of German Experimental Track.

and gravel ballast were used, the distribution of the ballast in the four sections being the same so that comparative tests could be made. In this manner a large number of stretches of experimental track were created which were carefully observed for settling and lateral movement as well as cost of maintenance. Movement in the track was measured by means of a graduated scantling laid crosswise over the track on posts set alongside. It was found, however, that such posts cannot be placed secure enough in the embankment to allow exact measurements to be made and securely anchored rails onto which metal strips have been bolted have now been substituted for the posts. The settlement at joints was measured by a graduated wedge which could be inserted under a straight edge laid over the top of the rail.

The maintenance of this road is under the direction of a roadmaster, a section foreman, two section hands and three guards, two of the latter being employed during the day and one at night. This force keeps the track and equipment in repair and keeps careful records of all costs. The instructions are to maintain the track to the same standard as that necessary for fast passenger and heavy freight service.

As examples of the tests which have been and are being carried on at this experimental station, the following are given: To determine the wear and deterioration of rails of various forms and laid by different processes, as for example, chrome, electro-steel, silicon steel, etc.; of ties of all forms and materials, of tie plates, fish plates, rail joints, screw spikes and rail faces, to test the various systems of roadbed construction, the various kinds of safety, switching and signaling devices, various oils and paints and track tools, such as rail saws, drills, wrenches, ballast forks, etc.

In discussing the results secured at this station, Colonel Samans of the Central Bureau of Railroads, which has charge of the experimental road, brought out the following points in justification of its continuance. It is frequently urged that in the development of railroading all types of construction should be tried in service under actual operating conditions. While it is admitted that experiments are necessary to determine the exact manner in which the track is being affected by the rolling stock, it is often considered that ample opportunities for such experi-

ments are to be had on existing lines. Such service tests are of value and on the state railways of Prussia and Hesse numerous stretches of track have been used for years for experimental purposes. On none of these stretches, however, is the entire track under observation in order to establish the laws governing the relation of its parts, but in each case some particular feature or noteworthy invention is being tried out. As a result of such tests there probably is no railroad management that has not been forced to trace back along some wrong path. The cause of this is in many cases due to the insufficient supervision given the test. The officer in charge can hardly give as much time to the observations as they require, and it is largely a matter of chance whether the men immediately concerned with the maintenance of the road can or will assist in the experiments. To observe and take measurements is not within everybody's scope of ability. Frequently only such things are seen as are expected and as correspond with one's previously fixed opinions. By the establishment of the station, all of these disadvantages have been eliminated and excellent results have been secured.

**THE THREE MEN TRACK LAYER.**

A new machine for saving labor in laying rail which was designed by P. H. Madden, roadmaster, Chicago, Milwaukee & St. Paul, Sparta, Wis., has recently been placed on the market. The machine is designed to be operated by three men, and consists essentially of a light steel frame supporting at the rear a drum operated by two cranks upon which is wound the hoisting chain. It can be operated either on four wheels or two, double flanged wheels being provided at the rear and plain wheels at the front, which are mounted upon axles that can be swung

ily moved without the use of the front wheels. If both rails are in position the front wheels can be swung into place and the machine operated on four wheels. If it is necessary to move rails, frogs or other heavy material, they may be swung from the hoisting chain and transported to any desired point on the four wheels.

The complete machine weighs less than a hand car and can

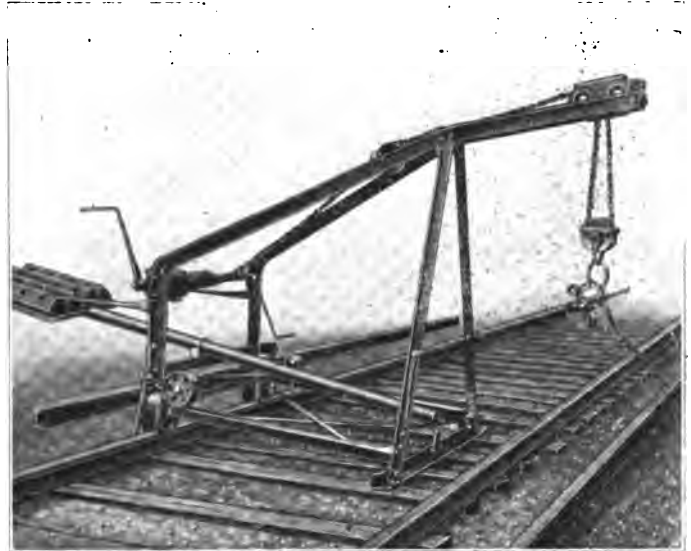

**Three Men Track Layer Equipped to Lay Rails.**

easily be lifted from the track and carried by four men. The machine can also be used as a substitute for the ordinary rail loader by placing it upon a flat car, allowing it to pick up rails from the ground and place them on roller blocks to be rolled endwise into stock, flat or gondola cars at either end of the flat car.

The machine has been thoroughly tested in service and is now being used at a number of points with good results. One of these machines in use on the main line of the C. M. & St. P.,

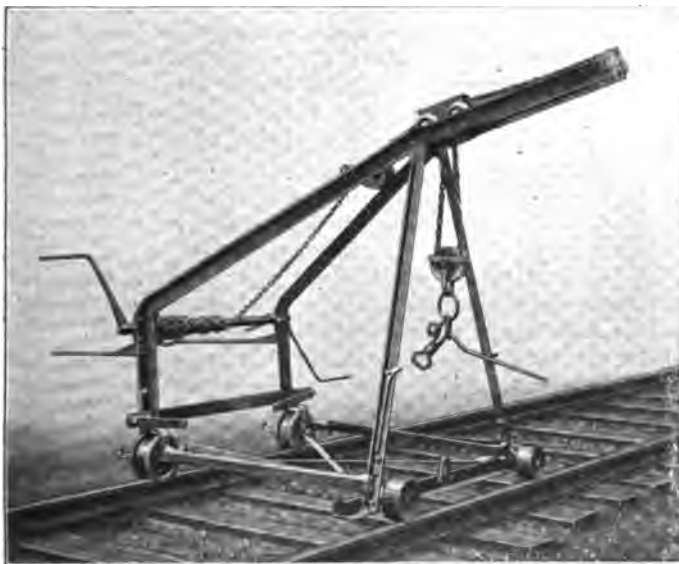

**Three Men Track Layer Mounted on Four Wheels.**

back under the frame when the machine is in use for laying track.

When the front wheels are swung back the steel A frame at the front of the machine rests upon the ties, giving the machine the stability necessary for pulling in and lifting the new rail. The hoisting chain with the rail tongs attached is run out far enough to allow the tongs to engage the new rail and the two men operating the drum can then drag in the rail to position. Having lifted out the old rail the new one is heeled in, two men operating the drum and the third man guiding the rail.

A detachable counterbalancing lever is provided, having a platform upon which splice bars, spikes, or other track material can be placed to balance the machine and to allow it to be read-



**Heeling In a 90-lb. Rail.**

between Russell, Ill., and Wadsworth, on July 23, laid 184 100-lb. rails in four hours. It was necessary to close up the track twice in this time for two passenger and one freight train, causing delays of 20 and 25 min., so that the actual working time was 3 hours and 15 min. The gang used in this case consisted of 71 men. Another machine is in use on the Janesville line



of the C. M. & St. P., near Grays Lake, laying 75-lb. rail. Each of these machines effected a saving of from nine to 16 men in the gang. Several of them have also been used on the Great Northern and the Northern Pacific for the past two years.

## AMERICAN RAILWAY BRIDGE AND BUILDING ASSOCIATION.

The twenty-third annual convention of the American Railway Bridge and Building Association will be held at the Windsor Hotel, Montreal, on October 21-23, 1913. Committee reports will be presented on the subjects of water supply, track scales, equipment and tools for bridge gangs, concrete culverts and various kinds of pipe for culverts; heating, lighting and ventilation of roundhouses and shops; motor cars for bridge gangs; temporary structures for supporting tracks during construction of permanent work, sewers, etc.; concrete posts, poles and signs; snow fences; preservation of timber, cattle guards and fire-resisting coatings for timber.

The programme is as follows:

### TUESDAY, OCTOBER 21.

#### Morning Session.

Call to order by the president at 10 o'clock.  
Prayer.  
Opening address by Wm. McNab, Principal Asst. Engr. Grand Trunk Ry.  
Response.  
Roll call (card registration system).  
Reading of minutes of last meeting.  
Report of executive committee.  
Reports of secretary and treasurer.  
Report of committees on membership, memoirs and relief.  
Election of new members.  
Recess to welcome new members and for the payment of dues.  
President's address.

#### Afternoon Session.

Call to order at 2 o'clock.  
Appointment of committees.  
Reports of committees on subjects.  
Discussion of reports.

#### Evening.

Meeting of executive committee at 7:30.

### WEDNESDAY, OCTOBER 22.

#### Morning Session.

Call to order at 9 o'clock.  
New business.  
Unfinished business.  
Reading of report of nominating committee.  
Reports of committees and discussion thereof.

#### Afternoon Session.

Call to order at 2 o'clock.  
Reading and discussion of committee.

### THURSDAY, OCTOBER 23.

#### Morning Session.

Call to order at 9 o'clock.  
Unfinished business.  
Election of officers.  
Selection of meeting place for 1914.  
Installation of officers.  
Adjournment.

The Committee on Arrangements has planned a visit to the new St. Lawrence River bridge and to the shops of the St. Lawrence Bridge Company's plant, where the Quebec bridge is being fabricated. On Friday a trip will be made by special train to Ottawa.

The steady growth of the association during the past year indicates that this convention will be successful both in the character of its discussions and in the attendance of its members. Arrangements are now being made for those members living west of Chicago to go in a party on special cars leaving Chicago on Sunday afternoon. Members or guests desiring to go with this party should advise the secretary, C. A. Lichty, C. & N. W. Ry., Chicago, as soon as possible.

## EXPLOSIVES FOR USE IN TUNNELING.

It is generally recognized that an explosive having a high disruptive force is preferable for tunnel work. On account of the cost of drilling holes it is usually more economical to drill a few holes and load them with an explosive of high disruptive force rather than to drill a larger number of holes and use a weaker and cheaper explosive. The only two classes of available explosives for this kind of work are "straight" nitro-glycerine dynamites and gelatine dynamites. It is also important for such work, which is done in closed spaces, that the explosive produce the minimum amount of poisonous gases. The gelatine dynamites, which are otherwise most suitable, are not satisfactory in this respect. According to Bulletin 48 of the Bureau of Mines, a formula for gelatine dynamite has been prepared by the bureau which shows on test no poisonous gases resulting from its detonation. This formula for 40 per cent. strength gelatine dynamite is as follows: nitro-glycerine, 33 per cent.; nitro-cellulose, 1 per cent.; sodium nitrate, 54 per cent.; combustible material (flour), 11 per cent., and calcium carbonate 1 per cent. It is believed by the bureau that this illustration of the possibility of producing a gelatine dynamite that will not evolve poisonous gases will result in its being commercially manufactured.

## THE FOREMAN PROBLEM.\*

By S. B. PETER,

Roadmaster, St. L. & S. F., Pittsburg, Kan.

There are two plans that I consider practical for solving the foreman problem.

The first is to increase the wages paid to section men to 17½ or even to 20 cents per hour, so that a better class of men might be secured. This would make it possible to secure American labor, or at least the better class of foreign labor, such as Irish, Scandinavian and German. This would not necessarily increase the payroll, as men could be secured at \$2 per day that would do as much work each day as two of the men that we get at \$1.25 per day. This would enable us to secure the material out of which the best foremen are made; and after we have secured the men, we should keep them in the service all the year around. The hiring of big gangs of Greeks and Mexicans for a few months in the summer and fall, and the cutting off of practically all the force during the winter months has created the foreman problem. Small gangs of good live men, at living wages, kept all the year will solve the problem, decrease the cost of maintenance, and insure us safer tracks.

Another plan that has been tried with a measure of success, is to employ a first man, or an assistant foreman on each section, selecting as far as practicable, young men with fair education, who are not afraid to work, and paying them 25 to 35 cents per day more than the regular section wages. This with the Sunday track walking enables them to earn from \$45 to \$50 per month. When such a man has been in service long enough to become competent, he is given charge of the section at any time the regular foreman is absent for any cause. By having a man of this kind in each gang a greater amount of work can usually be accomplished each day with the class of men we are now using, and there is always a man available who is competent to go to any point on the section to make repairs to broken rails, or do any of the small jobs that come up so frequently and do not require the service of the entire gang. This enables the foreman to stay with the gang and push the work. If occasion demands, the foreman can go and look after any small jobs or take a walk over his section, and be assured that the assistant will be looking after the work in his absence.

\*Received in the contest on The Foreman Problem which closed March 25, 1912.

## General News.

The United States district attorney at St. Louis has filed suit against the Illinois Southern to recover penalties of \$8,000 for alleged violations of the hours-of-service law and for failure to report such violations.

The Pennsylvania has issued orders to train conductors to visit sleeping cars at frequent intervals and see that either the conductor or the porter is on duty and alert for any emergency that may arise. Porters who have slept over a part of their run will have to change their habits.

James J. Hill entertained 360 members of the Veterans' Association of the Great Northern Railway, at Glacier Park, Montana, on September 16, Mr. Hill's seventy-fifth birthday. The association includes officers and employees who have been in the service of the company 25 years.

The Southern Pacific and the Order of Railroad Telegraphers have reached an agreement in a controversy which has been under dispute since last June. The agreement provides for an increase of wages of approximately 10 per cent., and changes of working conditions for about 1,200 operators.

Officers and employees of the Pennsylvania are now wearing on their coats a "safety button" about  $\frac{1}{2}$  inch in diameter. It is enameled in white, red, green and gold, and bears on its face the insignia of the railroad, a keystone, with the initials P. R. R. in the center, and the words "safety first" in the rim.

The Illinois Central and Yazoo & Mississippi Valley have created a weighing bureau at Chicago to take charge of the supervision of all matters pertaining to the ascertainment of correct weights and the assessment of revenue based thereon. The bureau will be in charge of Fred W. Souerby, who has been appointed superintendent of demurrage and weighing.

The Midland Valley Railroad has recently put in service between Wichita, Kan., and Arkansas City, 51 miles, a gas-electric motor car. The car makes one round trip a day. The running time each way is 2 hours 45 minutes, and there are seven regular stations and six flag stops. The car was made by the General Electric Company and is 71 ft. 8 in. long with passenger, smoking and baggage compartments.

The Manufacturers' Railway of St. Louis, which is owned by the same interests that own the Anheuser-Busch Brewing Association, on August 1 submitted to the 22 railways entering St. Louis a proposition providing for agreements for joint use of its facilities. On September 13 the proposition was withdrawn and it is reported that the company has purchased the St. Louis & O'Fallon Railway, and also has acquired trackage rights over the Alton & Southern.

Representative Willis, of Ohio, has introduced in Congress, a bill providing for the regulation of railroad scales by the Interstate Commerce Commission and making unlawful the use of any weighing device, for determining freight charges, which has not been approved by the commission. There is a provision that the American Railway Association shall establish a standard for scales and submit the same to the Interstate Commerce Commission for approval.

A press despatch from Jackson, Tenn., reports that an attempt to hold up a Mobile & Ohio northbound train on the night of September 13, was frustrated by an armed guard of fifteen men who had been expecting the holdup. The bandits, who had climbed aboard the engine at a point ten miles from Jackson, jumped when the firing began and escaped into the woods, firing back as they ran. No one was wounded so far as known. The posse left the train and began a search of the surrounding country for the robbers. A farmer who lives near the scene of the holdup and who was taken into the confidence of the bandits weakened and gave the information that prevented the robbery.

Committees representing the railroads, responding to an invitation from the Interstate Commerce Commission for suggestions concerning methods to be pursued by the government in making valuations of railroad property, have asked that they be permitted to file copies of maps already made (instead of

making new drawings) showing locations of road. It is estimated that to make entirely new drawings of all railroad lines would cost on the average \$20 a mile. In addition the railroads also object to any requirement being put upon them to furnish the boundaries of or information concerning adjacent lands or the names of the owners. The carriers have no right to enter upon the lands of others for the purpose of making surveys to obtain boundaries, and the names of the owners, particularly in the cities, are numerous and difficult to obtain, and when obtained would be of little value when placed on a map because of the constantly changing ownership.

### Special Despatch from Our Special Correspondent.

On Monday, September 1, for the first time in 44 years, Charles S. Mellen, ex-president of the New Haven, paid his fare on a railroad, going from West Stockbridge, Mass., to New York.

### Chicago Arbitrators' Decision.

W. J. Jackson, F. A. Burgess and E. C. Houston, the arbitrators appointed to decide questions of wages between the Chicago & Western Indiana and the Belt Railway of Chicago, and their locomotive enginemen, made their report on Tuesday of this week, and they held that the roads were not justified in paying the higher wages demanded by the employees, except that they awarded an increase in the work train rate from \$4.15 to \$4.40 a day. Some changes in working conditions were approved. The board found that these two roads were paying higher wages than are paid by the majority of Chicago lines for the same services.

### A Large Staff Meeting.

President Daniel Willard, of the Baltimore & Ohio, is presiding, this week at a meeting of the officers of the operating and engineering departments of the road. The meeting was announced to be held at Deer Park, Md., beginning Wednesday. Officers from the whole system, including the Cincinnati, Hamilton & Dayton, the Staten Island, the Sandy Valley and the Elkhorn lines were present, about 200 men in all. A number of special trains were run. The program provides for addresses from 20 officers, each speaking on the work of his department. Temporary offices were opened at Deer Park, with a special corps of telegraphers, stenographers, etc., so that officers remote from their headquarters could continue their business, so far as might be necessary, without interruption because of being absent from home.

### Safety at Grade Crossings.

The Pennsylvania Railroad has posted on the bulletin boards at all stations on the system a large bulletin, headed as above, and printed in two colors, calling attention to what it has done for safety at crossings. The bulletin is headed with a quotation from a letter by President Rea, saying: "The railroads are only too happy to remove all grade crossings, to equip every mile of track with automatic block signals, to make every car of all steel construction, but to do these things is utterly impossible without the money with which to pay for them." The main part of the bulletin is the following:

"There remain on the 11,000 miles of line comprising the Pennsylvania System 13,027 crossings at grade. It costs an average of at least \$50,000 to remove a grade crossing. Thus, to eliminate every such crossing on the lines of this system would cost upwards of \$600,000,000. The various companies of this system have since 1902 expended \$66,641,294 in improvements resulting in the elimination of 1,052 grade crossings."

The bulletin concludes with the following appeal to the public: "Grade crossings are unavoidable. Without them, few railroads could have been built in this country. They are one of the inconveniences of progress, to be eliminated just as fast as possible. Railroad officers are doing their best, but it all takes time and money. Meanwhile, the public demands that trains be run on time. To do so involves speed over crossings. The railroad appeals to the driver of every vehicle and every pedestrian before crossing a railroad track to 'STOP, LOOK, LISTEN.' A little care and a momentary stop may mean the saving of a human life.

"Human lives are the most precious things in the world."

### Pennsylvania Rules for Promotion of Firemen and Enginemen.

The Pennsylvania Railroad has issued rules on this subject substantially as follows:

A fireman will not be promoted to engineman unless he has had at least 528 days' experience as a fireman. The first promotion is to extra freight engineman; but this is conditional on the candidate having had at least 132 days' experience as road freight fireman, either through or local, immediately preceding his promotion.

Extra freight enginemen are promoted to regular freight enginemen.

Regular road freight enginemen are promoted to extra passenger enginemen, but always provided the candidate has had at least 528 days' experience as freight engineman, not less than 150 days of which must have been in road freight service, immediately preceding his promotion. This in no way depreciates the application of regulation No. 1.

Extra passenger enginemen are promoted to regular passenger enginemen.

A man going through the above grades must, of course, pass all the necessary examinations incident to each grade.

At the present time the average service of a fireman before promotion to engineman is from six to eight years.

### Arbitration of Trainmen's Wages.

The arbitrators who are to settle the controversy between the Eastern railroads and their conductors and brakemen, regarding wages—Messrs. A. H. Smith, W. W. Atterbury, D. L. Cease, Seth Low, J. H. Finley and L. C. Sheppard, began their sessions in New York City last week, and have taken a part of the testimony offered by the trainmen. Hon. Seth Low was chosen chairman of the board.

The representatives of the employees presented a large number of tables and diagrams to show the hazards of the trainmen's work, comparisons being made with the number of men killed and injured in 1902 and 1912; and the alleged special hazards of double head trains was emphasized. It was stated that large insurance companies have instructed their agents against writing life insurance policies for trainmen. On the Eastern roads the density of traffic has increased the risks to life and limb.

F. J. Warne, who presented the statistics on behalf of the trainmen, called attention to the increase in the size, weight and carrying capacity of freight cars during the past ten years.

Mr. Warne also presented voluminous statements to show that two-thirds of the railroads in the territory involved in this controversy are controlled by six of the large companies. Figures were given also to show the high cost of living at the present time as compared with former years.

### Promotions on the New Haven Road.

General Manager C. L. Bardo, following long discussions with representatives of the enginemen's brotherhood, has issued a revised code of rules for the promotion of firemen and enginemen. The enginemen's committee, talking to the reporters and giving expression to various objections to the action of the road, say that the runners will not refuse to abide by the regulations; but it is intimated that the campaign for modifications will be kept up. Mr. Bardo's statement is in substance as follows:

"Rights of engineers and firemen to preference of runs shall be governed by fitness, ability, previous service and seniority. An engineer or fireman losing his run, by reason of it having been discontinued, or having been taken by an engineer or fireman his senior, or for any reason not brought about by any fault or action of his own, shall be entitled, if competent, to any run on the same division held by an engineer or fireman his junior in seniority.

"No engineer who has had less than one year's road experience as an engineer shall be allowed to run local passenger trains, and no engineer who has had less than two years' road experience as an engineer shall be allowed to run express passenger trains.

"No engineer will be allowed to run either local or through passenger trains until his competency has been certified to by the road foreman of engines and master mechanic, unless accompanied by the road foreman of engines or other competent

employee, until his competency is determined and certified to.

"Spare passenger engineers will not be permitted to run express passenger trains unless they have served a satisfactory probationary period as fireman or engineer in freight or local passenger service over a reasonable portion of the territory covered by the run, unless accompanied by the road foreman of engines or other competent employee, until his competency is determined and certified to.

"No fireman will be eligible for assignment or advancement to through passenger service until his competency is established.

"The list of spare passenger engineers will be composed of men taken from road service.

"The division superintendent will be responsible for the enforcement of these rules and the maintenance of proper discipline on his division. The decision of the superintendent in all matters of discipline shall be final, unless an appeal is made as prescribed.

"Any appeal from the decision of the division superintendent as to discipline, rates of pay, or working conditions must be made in writing to the superintendent within thirty days of the date of notice to employee affected.

"An appeal from the decision of the division superintendent as to dismissal will not be entertained until after a joint statement containing all facts from the division superintendent and committees representing the aggrieved employee has been made to the general manager, who will, if the facts justify, authorize an appeal. This appeal will be heard by a committee appointed by the general manager, at which time both sides will be represented, and the decision of the board, or a majority of it, will be final."

In announcing the rules Mr. Bardo issued a statement saying:

"There is no intention on the part of the management to impose hardship or onerous condition upon its employees. The rules are solely intended to promote safety in operation. They do not in any way interfere with or change the hours of service, the rates of pay, or other working conditions, and they are practically the same as on many eastern roads. . . ."

In a letter to the engineers and firemen he said:

"These rules are designed and submitted after a convincing demonstration that our existing rules do not meet the exacting demands of the service and to comply with the recommendations of the Interstate Commerce Commission and the Public Utilities Commission of the state of Connecticut, and are for the sole purpose of increasing the safety of our service and for the protection of our patrons and employees. There is no desire on the part of the management to restrict the rights or withdraw from service any man who is physically fit and by experience qualified for his position. These rules will not interfere with the seniority of the men except where the question of fitness, ability, and previous service are involved, and since these requirements can be definitely fixed by the record and service of the men involved there is no opportunity for favoritism and none will be permitted."

The Brotherhood Committee asserts that orders to "make time" issued in 1911 and the disciplinary results which accompanied failure to "make time" were largely responsible for conditions which have "demoralized the force"; and that a restoration of the conditions which existed before 1911 would accomplish everything desired.

Regarding the proposed change in the rules for examination for color, sight and hearing the runners say that they "do not wish, or ask to have a man with poor vision on the front end of any train. The rule under which we have been working for the past thirteen years has proved to be sufficient in every respect. . . . We have made it plain that seniority had no bearing unless a man was competent, and of that the company would be the judge. We do not ask, nor do we want, incompetent men to run engines. All we ask is, that provided a man is competent his length of service for the company shall count."

### Three New Haven Trainmen Held.

Coroner Mix, of New Haven, on September 15, made his final report on the North Haven collision, and Engineman Miller, Flagman Murray and Conductor Adams are all held on criminal charges. Miller and Murray had been arrested the week pre-

vious, but the conductor is now held negligent in having entrusted flagging to Murray, "whom he had found to be careless and irresponsible." Engineman Wands, of train 91, is declared negligent in not properly observing the rules, but he is not held. The coroner says that questions of fixed signals and steel cars are not within his jurisdiction; they must be attended to by the State Public Utilities Commission. Miller is charged with manslaughter for "driving his locomotive recklessly, lawlessly, and at a high rate of speed." The testimony of engineers before the coroner was to the effect that the enclosed disk is a safe and efficient signal, had Engineman Miller observed the rules. It was Miller's duty to heed the signals, not relying in any degree on a warning of torpedoes or fusee. From the testimony presented before him, the coroner finds that the flagman had time to go back farther; he did not go immediately out when the train came to a stop, and he did not endeavor to go back the required distance. The coroner urges the Public Utilities Commission to make a thorough investigation of the system of discipline on the road.

#### The Prize for Enginemen.

Among the locomotive engineers who have responded to the offer of a prize of \$50 which was published in the *Railway Age Gazette* for August 15, and the *Journal of the Brotherhood of Locomotive Engineers* for September, in connection with a call for papers on *How to Keep a Perfect Lookout*, there is one, writing from Baltimore, who does not give his name. Readers are reminded that names are not to be published, except with the permission of the author; but they must be known to the Managing Editor (New York). Suppose this man should be entitled to the prize; how could it be sent to him? Our readers will be ready, like the philosopher, Emerson, to receive useful information from any source, but some knowledge of the writer's age and experience will be necessary in order to decide what is and what is not real information.

#### Public Should Pay for Steel Cars.

Close on the heels of the unfortunate accident on the New York, New Haven & Hartford, in which 21 persons were killed and a number of others were injured, comes the announcement from Washington that the Interstate Commerce Commission will force the railroads to provide steel passenger cars.

We think this is all right provided the Interstate Commerce Commission and the various legislatures will allow the railroads to raise the rate of fare. Surely the carriers cannot be expected to scrap millions of dollars' worth of equipment and buy new cars without some compensation for the loss, and surely the public does not expect the luxury of steel equipment without paying for it. Can it be that the American people do not comprehend the situation? Does the public think that the old adage about the rich people riding in chaises and the poor walking is not true in this day and generation?—*Manufacturers' News*.

#### Statistics of Failed Rails.

Bulletin No. 157 of the American Railway Engineering Association containing the rail failure statistics for the year ending October 31, 1912, has just been issued. These statistics are based on replies from 94 railways, with a total mileage of 182,000 miles, and include data on 14,132,982 tons of rail, of which 10,156,935 are Bessemer, 3,580,021 open hearth, and 396,026 miscellaneous alloy and special section rails. In addition to the usual diagrams and tables making comparisons of failures between different weights, sections and manufacturers of rail, additional data is given showing the results secured to date on numerous special tests in various parts of the country.

These statistics do not take into consideration differences in wheel loads, speed or tonnage passing over the rails. However, the averages are derived from a study of such large quantities of rails that they may be considered as fairly representing their performance. These statistics show that the average performance of the heavy sections (above 85 lbs.) is not as good as that of the lighter sections. The average rate of failure of open hearth rail is lower than that of Bessemer, although both are higher than for the previous year. The idea expressed in previous reports that possibly the rate of failure of open hearth rail will increase as its age increases so as to approach that of Bessemer rail is not corroborated by this year's figures,

the rate of failure of the Bessemer rail in 1912 being 116 per cent. higher than that of open hearth. It will be remembered that the early part of 1912 was marked by exceptionally severe weather, which was accompanied by an epidemic of broken rails. The committee repeats its conclusion of last year that the majority of failures was head failures, such as split or crushed heads, and was due, not to imperfect track conditions, but to defective material in the rail.

#### Railway Clubs and Safety First.

The common carriers of the country have learned that John Barleycorn in the habiliments of death sits at many a railroad crossing, at many a switch, and on many a siding, and rides upon the pilot of a hundred engines every day in the week. They might have nailed up the saloon door to their employees, and practically did so by forbidding a trainman under pain of discharge to enter any habitation where John Barleycorn had his domicile. The rule would have done little good if they had not discovered a more excellent way.

Block systems are good, and so are all other mechanical devices, but unless you get the man at the throttle valve to leave whiskey alone, deaths will occur on the track. By the introduction of a "more excellent way" a report upon the Southern Pacific system shows that in four years ended July 30, 1912, 150,000,000 persons had traveled on trains of that road "without killing a single passenger through collision or derailment." In one small railroad town of 3,000 inhabitants, twenty-nine saloons had flourished, and kept on flourishing in spite of the rule forbidding trainmen to patronize these places. Then the road introduced its "more excellent way" in the establishment of a clubhouse to take the place of the saloon, and six months later a dozen of the saloons had closed their doors because they would not pay. Two years after the club was opened, only seven of the twenty-nine saloons remained in business. Guidance was superior to obstruction, and education left prohibition away behind.

Something had to be done, for no man was required to pay entrance fees nor monthly dues to enter a saloon, so the railroads had to make their clubs as free as water that runs in the rivulet or as the air that circulates around the globe. The saloon is the most democratic place on earth, where all distinctions are left behind as each man enters the door. So in the clubs all men stand upon a plane of social equality. Another thing, the railroad clubhouses assume good behavior on the part of all who enter them, and there is never seen a sign prohibiting swearing, smoking, expectorating, or any other improper act. There are no "rules of conduct." The men are put upon their manhood and upon their good behavior. In an article in a recent issue of the *Outlook*, the discussion upon this subject closes as follows: "Social welfare workers will find food for reflection in the remarkable success of this enterprise, which vigorously suppressed every tinge of paternalism and patronage in order to lay hands upon the most elusive, unwitting individual, the adult, independent, self-respecting worker, and keep him out of danger, the danger zone of the saloon." And let all men rise up and sing Selah.—*Los Angeles Times*.

#### The Electric Headlight.

"In the Oklahoma Panhandle the first town made was Guymon. I had spent the afternoon there and intended to take a night train back to Liberal. A bunch of us were sitting on the front porch of the Commercial Hotel, playing cards, when I saw a headlight looming up down the track. I made a rush for my grips and yelled to the boy to get his cart and take 'em over to the depot quick.

"'How's this,' I said to the agent, 'I thought this train was not due for an hour, and here she is not a mile away.'

"'Mister,' he replied, 'you better go back to the hotel and buy cigars for that bunch. This is your first trip down here, isn't it? Well, I thought so. That headlight is just forty-nine miles away; you've got pretty near an hour to finish that game of pinocle. This is the longest straight and level track in the country—one hundred and seventy-six miles, clear across the Panhandle without a curve or a hill. You see that house over there? That's where I live. I don't have to have a light in a lamp until after nine o'clock winter nights. About sundown the Golden State Limited looms up down about Texhoma, and

she shines right into my kitchen window for an hour, finally getting so bright that my wife has to pull down the curtains. It's a great saving, and my wife won't wash dishes by anything but electric light, and the young folks play croquet in my yard by the light. I never have to call the despatcher to get the time on trains. I climb to the roof of the station, get a line on the headlight occasionally, and mark up my board accordingly. Have you any baggage to check?"—*Moberly Monitor*.

#### Discipline Without Suspension on the Canadian Government Railways.

F. P. Gutelius, who was recently appointed general manager of the Canadian Government Railways, the Intercolonial and the Prince Edward Island, has issued a circular stating that it is the intention to insist on a more rigid compliance with the rules and regulations, which are made for the protection of the lives of the public and employees, as well as for the protection of the railway's property.

All employees will start with a clean record, beginning September 1. Any exceptional service rendered will be credited to the employee's record. A monthly discipline list will be issued. This list will show cause, extent of discipline, or action and extent of reward.

Employees will, as heretofore, be subject to summary dismissal for insubordination, drunkenness on or off duty, using intoxicating liquor when on duty, frequenting saloons, or places of low repute, incompetency, dishonesty, failing to carry out train orders and rules respecting train movement. Where previously discipline was meted out by suspension demerit marks will be placed in the record of an employee. For every repetition of an offence by the employee, the number of demerit marks will be doubled. When the demerit marks against any employee number 60, his services will be dispensed with.

For every 12 consecutive months, good service, free from demerit marks, an employee will have 20 demerit marks deducted from those that may stand against his record. Employees will be advised when demerit marks are recorded against them, the same as they have hitherto been advised respecting disciplinary measures in the past.

#### Men Who Help Raise the Average of Safety.

J. J. Maroney, of Hartford, Conn., has taken a prize from a New York newspaper as the man who has traveled the greatest distance on a commutation ticket during the past five years. Mr. Maroney lives in Hartford, travels to and from New York daily, the round trip making 220 miles. In the five-year term he has made this round trip 1,414 times; estimated distance 311,080 miles. The prize is a free ticket for six months. Frederick H. Smith, of Newark, N. J., has taken a prize for the world's record for continuous daily travel to and from work. For 62 years, or since 1851, Mr. Smith has made the trip between Newark and New York, nine miles, twice a day, barring Sundays, holidays and vacations. The greatest mileage made in a single year is placed to the credit of W. I. Lex, of Philadelphia, who made 55,325 miles between his home city and New York from July 1, 1908, to July 1, 1909.

A man writing from Pittsburgh claims that a resident of Leetsdale, Pa., has traveled more miles than Mr. Smith. He says: On a basis of 300 days to the year, eighteen miles a day and sixty-two years Smith's total mileage would be 334,800. This does not allow for vacations and sickness. I am acquainted with a gentleman living at Leetsdale, on the Pittsburgh, Fort Wayne & Chicago, fifteen miles from Pittsburgh, and he has been traveling between these points 55 years. Deducting a total of twelve years for vacations, sickness and some winters spent in the city, there would be forty-three years at thirty miles a day, 300 days a year, or a total of 387,000 miles, which is 52,200 more miles than the Newark record.

#### Governor Foss on Bankers, Brotherhoods and Interlocking.

The bankers and trunk lines that control the New England transportation system are interlocked, and in that interlocking there is no voice of New England. Three financial interests in New York City are the central money power of this country. These banks dominate the transportation system of all New England.

The engineer of the locomotive should owe his allegiance

to the railroad corporation, and the corporation should protect him and safeguard him in every way. But today, does the railroad engineer in New England recognize any allegiance superior to that of his labor union? Railroad men will tell you he does not. And the reason is perfectly clear. It is his union that has multiplied his wages to five-fold beyond what the engineer on the European train, doing the same work, receives as compensation. Have the wages of the unorganized trackmen or the unorganized gatemen been raised in proportion to the advance in the cost of living? Why not? The engineers of New England, substantially all of whom are enrolled in one labor union, are able at any moment to threaten a strike and paralyze the industries of New England in a day, if their demands are not complied with. What can the railroad officials do? Yield to every demand of the engineers and deny most of the demands of unorganized labor at the foot of the ladder? I am only asking you questions. I am not making assertions except as they are supported by official testimony.

I stand here as an independent citizen, wearing the cloak and collar of no party, and I denounce the foreign control of the New England railroads, and denounce the foreign control of the labor that captains the iron horses at the head of every passenger train in New England.—*Gov. E. N. Foss, of Massachusetts; speech at Worcester.*

#### Secret of Strength of C. N. R.

Sir William Mackenzie is Irish, and it is said of the Irish that they can "charm the birds from the bushes." At any rate, the British money market has never been able to say "No" to Sir William. He always comes back from London with the big "wad" sticking out of his hip pocket.

Of Sir William it is said that he can charm the money out of the reluctant British pocket. That pocket is never reluctant when Sir William fastens his blue eye on the British investor. He finds the man who must hear him, and to him he waxes eloquent. The market may be cautious. Money may be tight, but Sir William returns with the needed millions. There is something of mystery about the man and his methods. Other railway people have the chagrin of seeing their loans go a-begging sometimes.

The Canadian Northern is young; it is not completed; it is a one-man corporation; it began on nothing; it fed itself, section by section, and when it asks for \$20,000,000 the British investor who has been adamant to municipal securities, and even turned a deaf ear to such well-known people as the Grand Trunk (upon occasion), reaches down into his pocket and brings up the desired simoleons, to the requisite amount, and even more.

Then Sir William returns and things hum. The gaps are filled up, the line becomes continuous, the blasts are bigger in the tunnel, the big terminals in Montreal take shape—all nebulous as they have been and when you ask Sir William if there is not a stringency in the British money market he says innocently: "There may be. I did not encounter it."—*Exchange.*

#### Block Signals and Automatic Stops in Congress.

Representative Esch, of Wisconsin, who for several years back has introduced in Congress at each session a bill providing a scheme for making the use of the block system compulsory on the railroads throughout the United States, has introduced it this year (H. R., 8046, September 10) in a modified form, making action by the Interstate Commerce Commission mandatory instead of permissive ("shall" order the carriers to, act) and including a section providing that the Commission may, on six months' notice, order a road to install automatic train control devices on any line where the block system is in use. It appears from the *Congressional Record* that Representative Mann, of Illinois, who introduced the resolution which was adopted on September 6 (noticed last week, page 470), and which carried an appropriation of \$25,000 for investigation, aimed simply to restore the "Block Signal and Train Control Board" or to establish a new board with similar functions, the idea being, apparently, to make it permanent. The full resolution is in substantially the same language as the laws of June 30, 1906, and May 27, 1908, under which the Block Signal Board acted. In the course of the discussion in Congress one mem-

ber of the House reported Mr. Prouty, of the Interstate Commerce Commission, as saying that the Commissioners did not want any such appropriation at this time; that they proposed to deal with the subject constructively next December (when they will send to Congress their annual report). The vote on Mr. Mann's resolution was taken in Committee of the Whole, and was 34 to 30. The urgent deficiency bill, of which this is a part, has not yet come up in the Senate.

**Methods of Surety Companies.**

It is because the private individual cannot afford to give bonds for strangers that surety companies have come into existence. You cannot afford to give a bond for a friend. Nowadays such requests are not often made. The surety business has advanced in this country during the last fifteen years until it has now reached the stage where it reckons its gains and losses by millions. . . . Since beginning business twenty-five years ago one surety company has smarted to the tune of fourteen million dollars, most of which has been lost on badly placed risks in the last ten years. But that one may smart and still smile may be judged from the fact that the net annual profits of that same company have been from 20 to 30 per cent. "There is no business in the world," said the manager of a big New York bonding company, "in which you get such a close view of the vagaries of human nature. In spite of great losses this business makes optimists of all of us who are in it. We find far more good than evil in men." Every day in the year men who ask for bonds as cashiers, ticket agents, postmasters, and treasurers are rejected because it is discovered that they have extravagant wives. Another extra hazard is the county treasurer. If he hadn't been a good fellow, he probably wouldn't have been elected. He owes debts of gratitude, and something more solid than gratitude, to all the fellows who helped him into office. One risk is so hazardous that it is simply out of the question. That is the fourth-class postmaster, whom the surety company will not touch because he is so frequently touched by gentle rogues of all kinds. Many companies will not bond sheriffs, marshals and other police officers, for they and their sureties are liable for damages due to unwarranted arrests. Add this contingency to the likelihood of default, and you have a risk that is simply impossible. It is toward the end of the first term or anywhere in the second that defalcations are most numerous. In other words, all men generally start out in their official career to be honest, and are honest until continued temptation gets the better of them.

A red-haired, blue-eyed ticket agent of the Southern Railway in a good-sized town was so honest that he wouldn't use one of the company's stamps on a private letter. One night his office was entered by two masked men who leveled pistols at his head and commanded him to open his safe and shell out its contents, about three thousand dollars. The red-headed hero refused to comply with the demand.

"Not on your life!" he replied to the robber who gave the peremptory order. "I'm here in charge, and I'd rather die than hand out that money!"

"I guess you'll die then," was the cool reply. And with the remark went a bullet.

Three times the robbers fired at the hero with the red hair, and each shot took effect. The victim fell to the floor, and the robbers left him for dead; but they took no money with them. The railroad company gave the hero a gold watch properly inscribed, and when he was well enough to go back on the job again they raised his salary. Within six months Mr. Hero lit out for Canada with four thousand dollars of the company's money, which was made good by a surety company. He married soon after his raise of salary to a tender young thing who had to wear five-dollar silk stockings and fifty-dollar switches.

Of late years surety companies have become rather lenient with defaulters. There are today in this country hundreds of defaulters who are paying back in small instalments money lent them by bonding companies in lump sums to save them from prison. This letting a man make good and not prosecuting him, as surety companies so often do nowadays, would seem to be skimming pretty closely to the line of compounding a felony. Though in the eye of the law the embezzler is just as much a criminal as the safe breaker, with the average man who knows poor, weak human nature and what a continuous

round of temptation is the daily handling of other people's money there is always a feeling of leniency. If an embezzler has made good it would be a waste of time to prepare a case and bring him into court. Not once in a hundred times could he be indicted by a grand jury. Grand juries are only human, and this making-good business makes a mighty strong appeal to them. . . . The fact that so many surety companies have gone under of late is not due so much to lack of public confidence as to tremendous competition.—*New York Tribune.*

**Maintenance of Way Master Painters' Association of United States and Canada.**

The tenth annual convention of the Maintenance of Way Master Painters' Association of the United States and Canada will be held at the Hotel Henry Watterson, Louisville, Ky., November 18-20. A very cordial invitation is extended to all railroad engineers of test, engineers maintenance of way, division engineers, engineers of structures, supervisors of bridges and buildings, master painters of steam and electric roads to attend, furnish papers for discussion, and to encourage others to attend. List of open questions for discussion on which papers may be written are: Safety First; How Best to Prevent Accidents and Occupational Diseases. Value of Railroad Painting; Decorating and Neatness of Appearance as Advertising. Efficiency and Economy in Railroad Structural Steel Painting. What is the Most Effective Way of Protecting the Interior of Steel Tanks from Corrosion by the Effects of Different Kinds of Water? Value of Heavy Coatings on Horizontal Parts and on Solid Bridge Floors. What is the Best Practice in Taking Care of Signal Painting? How Can We Best Take Care of Structures Exposed to Exhaust of Engines, Smoke, Gases, etc.? Paint Oils, Other than Linseed. Inside Flat Finishes for Stations and Buildings. Contracting of Railroad Painting. Painting of Concrete and Cement Work. All subjects of interest to railroad maintenance so far as economy, preservation of structures and beauty of appearance is concerned. Typewritten copies of papers are requested to be mailed to the secretary by October 1.

**Pennsylvania Industrial Welfare Efficiency Convention.**

The Pennsylvania Industrial Welfare and Efficiency Convention will be held in the capitol at Harrisburg, Pa., October 28-30. The convention has been called by the Hon. John Price Jackson, commissioner of labor and industry and will consist of representatives of industrial establishments, engineers, contractors and other employers of labor doing business in Pennsylvania and representatives of labor, and heads of the various state departments coming in contact with engineering and industrial affairs of the state. The exhibit to be held in connection with the convention will be of a general engineering nature to appeal to the type of delegates attending the convention. The price for floor space will be 40 cents per sq. ft., including the standard booth, decorations, signs and reasonable amount of electric, steam, or compressed air power. These exhibits will be held in the building of the Harrisburg Railways Company, where about 26,000 sq. ft. of concrete floor space will be available. J. V. W. Reynders, vice-president of the Pennsylvania Steel Company, Steelton, Pa., is chairman of the exhibit committee.

**Railway Signal Association.**

The eighteenth annual convention of the Railway Signal Association will be held at the Hermitage, Nashville, Tenn., October 14-17. On October 14 there will be the president's address and reports of the committees on Signalling Practice; Mechanical Interlocking; Power Interlocking; Automatic Block; Manual Block; and on Subjects and Definitions.

On October 15 there will be reports of the committees on Standard Designs; Electric Railways and Alternating Current Signalling; and on Wires and Cables.

On October 16 there will be reports of the committee on Storage Batteries and Charging Equipment; and reports of the special committees on Methods of Recording Signal Performance; State of Signalling in the Northwest; and on Specifications for Low Tension Wire Crossings.

Friday, October 17, will be devoted entirely to entertainments,

which will include a trip to Lookout Mountain in the morning, a buffet luncheon at the hotel Patten, and a trip to Chickamauga park and battlefield in the afternoon. Entertainments will also be provided for the first three days of the convention, including the annual dinner at the Hotel Hermitage on October 15.

#### Railway Club of Pittsburgh.

The members of the Railway Club of Pittsburgh and their guests will be given a day of outing and entertainment by the Westinghouse Air Brake Company at Wilmerding, Pa., on September 26. A special train will leave the Pennsylvania station, Pittsburgh, at 2:45 p. m., for Wilmerding, and upon arrival at that point the party will be conducted through the works of the Westinghouse company. In the evening the club will hold its regular meeting and entertainments will be provided. The party will return to Pittsburgh about 10 p. m.

#### American Electric Railway Association.

The American Electric Railway Association will hold its annual convention at Atlantic City, N. J., October 13-17. Some of the principal topics to be discussed will be Unsightly Poles; Profit Sharing with Employees; The Relation of Carriers to the Development of the Territory They Serve; Relief of City Congestion; Present Tendency of Public Service Laws, and Regulations; Valuation; and Electric Railway Securities from the Investor's Viewpoint.

#### Bridge and Building Supplymen's Association.

The Bridge & Building Supplymen's Association will hold its annual meeting at the Hotel Windsor, Montreal, Que., October 21-23, in connection with the annual convention of the American Railway Bridge & Building Association.

### MEETINGS AND CONVENTIONS.

*The following list gives names of secretaries, dates of next or regular meetings, and places of meeting.*

- AIR BRAKE ASSOCIATION.**—F. M. Nellis, 53 State St., Boston, Mass. Next convention, May, 1914.
- AMERICAN ASSOCIATION OF DEMURAGE OFFICERS.**—A. G. Thomason, Boston, Mass. Convention, May 19, 1914, St. Louis.
- AMERICAN ASSOCIATION OF GENERAL PASSENGER AND TICKET AGENTS.**—W. C. Hope, New York. Annual meeting, October 14-15, Philadelphia, Pa.
- AMERICAN ASSOCIATION OF FREIGHT AGENTS.**—R. O. Wells, East St. Louis, Ill. Next convention, April 21, Houston, Tex.
- AMERICAN ASSOCIATION OF RAILROAD SUPERINTENDENTS.**—E. H. Hartman, St. Louis, Mo.; 3d Thursday and Friday in May.
- AMERICAN ELECTRIC RAILWAY ASSOCIATION.**—H. C. Donecker, 29 W. 39th St., New York. Next convention, October 13-17, Atlantic City, N. J.
- AMERICAN ELECTRIC RAILWAY MANUFACTURERS' ASSOC.**—H. G. McConaughy, 165 Broadway, New York. Meetings with Am. Elec. Ry. Assoc.
- AMERICAN RAILWAY ASSOCIATION.**—W. F. Allen, 75 Church St., New York. Next meeting, November 19, 1913, Chicago.
- AMERICAN RAILWAY BRIDGE AND BUILDING ASSOCIATION.**—C. A. Lichty, C. & N. W., Chicago. Convention, October 21-24, 1913, Montreal.
- AMERICAN RAILWAY ENGINEERING ASSOCIATION.**—E. H. Fritch, 900 S. Michigan Ave., Chicago. Next convention, March 17-20, Chicago.
- AMERICAN RAILWAY MASTER MECHANICS' ASSOCIATION.**—J. W. Taylor, Old Colony building, Chicago.
- AMERICAN RAILWAY TOOL FOREMEN'S ASSOCIATION.**—A. R. Davis, Central of Georgia, Macon, Ga.
- AMERICAN SOCIETY FOR TESTING MATERIALS.**—Prof. E. Marburg, University of Pennsylvania, Philadelphia, Pa.
- AMERICAN SOCIETY OF CIVIL ENGINEERS.**—C. W. Hunt, 220 W. 57th St., New York; 1st and 3d Wed., except June and August, New York.
- AMERICAN SOCIETY OF ENGINEERING CONTRACTORS.**—J. R. Wenlinger, 11 Broadway, New York; 2d Tuesday of each month, New York.
- AMERICAN SOCIETY OF MECHANICAL ENGINEERS.**—Calvin W. Rice, 29 W. 39th St., New York.
- AMERICAN WOOD PRESERVERS' ASSOCIATION.**—F. J. Angier, B. & O., Baltimore, Md. Next convention, January 20-22, 1914, New Orleans, La.
- ASSOCIATION OF AMERICAN RAILWAY ACCOUNTING OFFICERS.**—C. G. Phillips, 143 Dearborn St., Chicago. Annual meeting, May 28, Atlantic City, N. J.
- ASSOCIATION OF RAILWAY CLAIM AGENTS.**—C. W. Egan, B. & O., Baltimore, Md. Next convention, May, 1914, St. Paul, Minn.
- ASSOCIATION OF RAILWAY ELECTRICAL ENGINEERS.**—Jos. A. Andreucetti, C. & N. W. Ry., Chicago. Annual convention, October 18-24, Chicago.
- ASSOCIATION OF RAILWAY TELEGRAPH SUPERINTENDENTS.**—P. W. Drew, 112 West Adams St., Chicago. Next convention, May 20-23, New Orleans, La.
- ASSOCIATION OF TRANSPORTATION AND CAR ACCOUNTING OFFICERS.**—G. P. Conard, 75 Church St., New York. Next meeting, December 9-10, Galveston, Tex.
- ASSOCIATION OF WATER LINE ACCOUNTING OFFICERS.**—W. R. Evans, Chamber of Commerce, Buffalo, N. Y. Annual meeting, October 8, Philadelphia, Pa.
- BRIDGE AND BUILDING SUPPLY MEN'S ASSOCIATION.**—H. A. Neally, Joseph Dixon Crucible Co., Jersey City, N. J. Meeting with American Railway Bridge and Building Association.
- CANADIAN RAILWAY CLUB.**—James Powell, Grand Trunk Ry., Montreal, Que.; 2d Tuesday in month, except June, July and Aug., Montreal.
- CANADIAN SOCIETY OF CIVIL ENGINEERS.**—Clement H. McLeod, 413 Dorchester St., Montreal, Que.; Thursday, Montreal.
- CAR FOREMEN'S ASSOCIATION OF CHICAGO.**—Aaron Kline, 841 North 50th Court, Chicago; 2d Monday in month, Chicago.
- CENTRAL RAILWAY CLUB.**—H. D. Vought, 95 Liberty St., New York; 2d Thurs. in Jan. and 2d Fri. in March, May, Sept., Nov., Buffalo, N. Y.
- CIVIL ENGINEERS' SOCIETY OF ST. PAUL.**—L. S. Pomeroy, Old State Capitol building, St. Paul, Minn.; 2d Monday, except June, July, August and September, St. Paul.
- ENGINEERS' SOCIETY OF PENNSYLVANIA.**—E. R. Dasher, Box 704, Harrisburg, Pa.; 1st Monday after 2d Saturday, Harrisburg, Pa.
- ENGINEERS' SOCIETY OF WESTERN PENNSYLVANIA.**—E. K. Hiles, Oliver building, Pittsburgh; 1st and 3d Tuesday, Pittsburgh, Pa.
- FREIGHT CLAIM ASSOCIATION.**—Warren P. Taylor, Richmond, Va. Next convention, May 20-22, Galveston, Tex.
- GENERAL SUPERINTENDENTS' ASSOCIATION OF CHICAGO.**—E. S. Koller, 226 W. Adams St., Chicago; Wed. preceding 3d Thurs., Chicago.
- INTERNATIONAL RAILWAY CONGRESS.**—Executive Committee, 11, rue de Louvain, Brussels, Belgium. Convention, 1915, Berlin.
- INTERNATIONAL RAILWAY FUEL ASSOCIATION.**—C. G. Hall, 922 McCormick building, Chicago. Annual convention, May 18-22, Chicago.
- INTERNATIONAL RAILWAY GENERAL FOREMEN'S ASSOCIATION.**—Wm. Hall, 829 West Broadway, Winona, Minn. Next convention, July, Chicago.
- INTERNATIONAL RAILROAD MASTER BLACKSMITHS' ASSOCIATION.**—A. L. Woodworth, Lima, Ohio. Next convention, third Tuesday in August.
- MAINTENANCE OF WAY & MASTER PAINTERS' ASSOCIATION OF THE UNITED STATES AND CANADA.**—W. G. Wilson, Lehigh Valley, Easton, Pa. Next convention, November 18-20, Louisville, Ky.
- MASTER BOILER MAKERS' ASSOCIATION.**—Harry D. Vought, 95 Liberty St., New York.
- MASTER CAR BUILDERS' ASSOCIATION.**—J. W. Taylor, Old Colony building, Chicago.
- MASTER CAR AND LOCOMOTIVE PAINTERS' ASSOC. OF U. S. AND CANADA.**—A. P. Dane, B. & M., Reading, Mass.
- NATIONAL RAILWAY APPLIANCE ASSOC.**—Bruce V. Crandall, 537 So. Dearborn St., Chicago. Meetings with Am. Ry. Eng. Assoc.
- NEW ENGLAND RAILROAD CLUB.**—W. E. Cade, Jr., 683 Atlantic Ave., Boston, Mass.; 2d Tuesday in month, except June, July, Aug. and Sept., Boston.
- NEW YORK RAILROAD CLUB.**—H. D. Vought, 95 Liberty St., New York; 3rd Friday in month, except June, July and August, New York.
- NORTHERN RAILROAD CLUB.**—C. L. Kennedy, C. M. & St. P., Duluth, Minn.; 4th Saturday, Duluth.
- PEORIA ASSOCIATION OF RAILROAD OFFICERS.**—M. W. Rotchford, Union Station, Peoria; 2d Thursday.
- RAILROAD CLUB OF KANSAS CITY.**—C. Manlove, 1008 Walnut St., Kansas City, Mo.; 3d Friday in month, Kansas City.
- RAILWAY BUSINESS ASSOCIATION.**—Frank W. Noxon, 2 Rector St., New York. Annual dinner, second week in December, 1913, New York.
- RAILWAY CLUB OF PITTSBURGH.**—J. B. Anderson, Penna. R. R., Pittsburgh, Pa.; 4th Friday in month, except June, July and August, Pittsburgh.
- RAILWAY ELECTRICAL SUPPLY MANUFACTURERS' ASSOC.**—J. Scribner, 1021 Monadnock Block, Chicago. Meetings with Assoc. Ry. Elec. Engrs. Mobile, Ala. Next meeting, October 7, Chicago.
- RAILWAY FIRE PROTECTION ASSOCIATION.**—C. B. Edwards, Mobile & Ohio, Mobile, Ala. Next meeting, October 7, Chicago.
- RAILWAY GARDENING ASSOCIATION.**—J. S. Butterfield, Lee's Summit, Mo.
- RAILWAY DEVELOPMENT ASSOCIATION.**—W. Nicholson, Kansas City Southern, Kansas City, Mo.
- RAILWAY SIGNAL ASSOCIATION.**—C. C. Rosenberg, Bethlehem, Pa. Convention, October 14, Nashville, Tenn.
- RAILWAY STOREKEEPERS' ASSOCIATION.**—J. P. Murphy, Box C, Collinwood, Ohio.
- RAILWAY SUPPLY MANUFACTURERS' ASSOC.**—J. D. Conway, 2135 Oliver bldg., Pittsburgh, Pa. Meetings with M. M. and M. C. B. Assocs.
- RAILWAY TEL. & TEL. APPLIANCE ASSOC.**—W. E. Harkness, 284 Pearl St., New York. Meetings with Assoc. of Ry. Teleg. Sups.
- RICHMOND RAILROAD CLUB.**—F. O. Robinson, Richmond, Va.; 2d Monday except June, July and August.
- ROADMASTERS' AND MAINTENANCE OF WAY ASSOCIATION.**—L. C. Ryan, C. & N. W., Sterling, Ill.
- ST. LOUIS RAILWAY CLUB.**—B. W. Frauenthal, Union Station, St. Louis, Mo.; 2d Friday in month, except June, July and Aug., St. Louis.
- SIGNAL APPLIANCE ASSOCIATION.**—F. W. Edmonds, 3868 Park Ave., New York. Meeting with annual convention Railway Signal Association, Chicago. Annual meeting, September 23-25, Chicago.
- SOCIETY OF RAILWAY FINANCIAL OFFICERS.**—C. Nyquist, La Salle St. Station, Chicago. Annual meeting, September 23-25, Chicago.
- SOUTHERN ASSOCIATION OF CAR SERVICE OFFICERS.**—E. W. Sandwich, A. & W. P. Ry., Montgomery, Ala. Annual meeting, October 16, 1913, Atlanta, Ga.
- SOUTHERN & SOUTHWESTERN RAILWAY CLUB.**—A. J. Merrill, Grant bldg., Atlanta, Ga.; 3d Thurs., Jan., March, May, July, Sept., Nov., Atlanta.
- TOLEDO TRANSPORTATION CLUB.**—J. G. Macomber, Woolson Spice Co., Toledo, Ohio; 1st Saturday, Toledo.
- TRACK SUPPLY ASSOCIATION.**—W. C. Kidd, Ramapo Iron Works, Hillsburn, N. Y. Meeting with Roadmasters' and Maintenance of Way Association.
- TRAFFIC CLUB OF CHICAGO.**—W. H. Wharton, La Salle Hotel, Chicago.
- TRAFFIC CLUB OF NEW YORK.**—C. A. Swope, 290 Broadway, New York; last Tuesday in month, except June, July and August, New York.
- TRAFFIC CLUB OF PITTSBURGH.**—D. L. Wells, Erie, Pittsburgh, Pa.; meetings monthly, Pittsburgh.
- TRAFFIC CLUB OF ST. LOUIS.**—A. F. Versen, Mercantile Library building, St. Louis, Mo. Annual meeting in November. Noonday meetings October to May.
- TRAIN DESPATCHERS' ASSOCIATION OF AMERICA.**—J. F. Mackie, 7122 Stewart Ave., Chicago. Next convention, June 16, Jacksonville, Fla.
- TRANSPORTATION CLUB OF BUFFALO.**—J. M. Sells, Buffalo; first Saturday after first Wednesday.
- TRANSPORTATION CLUB OF DETROIT.**—W. R. Hurley, L. S. & M. S., Detroit, Mich.; meetings monthly.
- TRAVELING ENGINEERS' ASSOCIATION.**—W. O. Thompson, N. Y. C. & H. R., East Buffalo, N. Y. Next meeting, Chicago.
- UTAH SOCIETY OF ENGINEERS.**—Fred D. Ulmer, Oregon Short Line, Salt Lake City, Utah; 3d Friday of each month, except July and August.
- WESTERN CANADA RAILWAY CLUB.**—W. H. Rosevar, P. O. Box 1707, Winnipeg, Man.; 2d Monday, except June, July and August, Winnipeg.
- WESTERN RAILWAY CLUB.**—J. W. Taylor, Old Colony building, Chicago; 3d Tuesday of each month, except June, July and August.
- WESTERN SOCIETY OF ENGINEERS.**—J. H. Warder, 1735 Monadnock Block, Chicago; 1st Monday in month, except July and August, Chicago.

# Traffic News.

The Louisville & Nashville is to open a city ticket office in Pensacola, Fla., with A. C. Ryals in charge.

The Southern Railway has established an office of its land and industrial department at Denver Colo., with H. R. Buckey in charge.

The Traffic Club of Chicago held an outing at the Midlothian Country Club on September 17. The program included a golf tournament, base ball game and tennis.

President Willard of the Baltimore & Ohio announces that the new freight tariff to be filed by all the eastern and central traffic roads, advancing rates 5 per cent., will be ready by October 1.

In consequence of the drouth in Kansas, large numbers of cattle are being shipped from that state to Texas and Oklahoma. Ninety-one cars of cattle passed through Denison southward September 10. The Missouri, Kansas & Texas expects to carry more than 400 carloads.

At a meeting of the Central Passenger Association in Chicago on September 10, it was decided to put into effect a charge for handling prepaid orders for tickets either by telegraph or telephone on the basis of 1 per cent. of the amount of the order, but not less than 25 cents or more than \$1.

The Southern Pacific has announced that a "Sunset Limited" train will be put into service on November 16 between New Orleans and Los Angeles and San Francisco. Time will be 60 hrs. 45 min. from New Orleans to Los Angeles, and 58 hrs. 35 min. eastbound. The train will be run daily and no extra fare will be charged.

The United Fruit Company, running steamships between the United States and Central American ports, expects to carry 20,000 passengers to Panama during the coming excursion season, which includes the months of December, January, March and April. A large number of passengers have already engaged accommodations and it is believed that at least 12,000 will sail from New York City. Over 7,000 will probably go from New Orleans.

The Texas Railroad Commission has filed a suit in the United States district court at Austin, Tex., against the International & Great Northern, asking for penalties to the amount of \$5,000, and an injunction compelling the road to obey the commission's order to continue to absorb loading charges at the ports. The suit is on a test case agreed upon by the railways and the commission to determine whether freight billed to Texas ports and then re-consigned to other points in the state is to be considered interstate or intrastate business.

The largest volume of freight tonnage ever transported by the St. Louis railroads in the first half of any year was recorded for the six months ended June 30, 1913, according to statistics

compiled by Eugene Smith, secretary of the Merchants' Exchange, from reports prepared by the St. Louis carriers. The gross traffic for the six months was 26,680,815 tons. In comparison with the corresponding period of 1912, there was an increase of 3,090,734 tons, equivalent to 13.06 per cent. The gain over the first six months of 1909, five years ago, was 31.83 per cent., or 6,418,786 tons. The receipts for the first half of 1913 amounted to 15,897,246 tons, and the shipments to 10,783,569 tons.

The principal express companies have applied to the Interstate Commerce Commission for an extension of time in which to prepare and put into effect the rates for transportation of merchandise ordered by the commission in August. By the terms of the commission's order the rates would become effective on October 15. The companies say that it will be impossible to comply with the order by that date. Walker D. Hines, speaking for the five companies, expressed their willingness to comply generally with the provisions of the commission's order, but suggested certain modifications not affecting it in principle. Washington reports say that little doubt exists that the commission will grant the application, inasmuch as the companies agree to comply with the order.

The New York, New Haven & Hartford has lately put in service in New York harbor four steel car floats which are believed to be the largest in use. Each float has 17 watertight compartments, making it practically non-sinkable. The vessels are 343 ft. 6 in. long, 40 ft. 1 in. wide and draw five feet when loaded. They carry 22 cars each. The new floats are for use on the car ferry to the Pennsylvania, Jersey Central and Lehigh Valley terminals. On the average 2,100 cars a day are floated between these points. On August 11 two of these floats, lashed to one of the New Haven's tugs, transported 50 loaded freight cars. The cars and their contents weighed 3,341 tons. The New Haven's floating equipment in New York harbor now comprises fifty car floats and eighteen tugs. Of the tugs nine are of 1,000 horsepower and two are of 1,200 horsepower.

### The Railroad Agriculturist Supplanted?

A press despatch from Towanda, Pa., says that the Pennsylvania State Department of Agriculture during the next few months is to run a special train, carrying a kitchen on wheels, throughout the northern part of that state for the purpose of instructing farmers' wives. Demonstrators will show how to conduct a model kitchen and approved methods of domestic science will be exemplified. The kitchens will be equipped with sanitary plumbing and the latest devices for cooking. The exhibit will be in charge of Mrs. Jean Folke, a state instructor in household economics.

### Car Location.

The accompanying table, which was taken from bulletin No. 9-A of the American Railway Association, gives a summary of freight car location by groups on August 15, 1913.

	CAR LOCATION ON AUGUST 15, 1913.												Grand Total.
	New England.	N.Y., N.J., Del., Md., Eastern Pa.	Ohio, Ind., Mich., Western Pa.	Va., W. Va., No. & So. Carolina.	Ky., Tenn., Miss., Ala., Ga., Fla.	Iowa, Ill., Wis., Minn.	Mont., Wyo., Neb., Dakotas.	Kans., Colo., Okla., Mo., Ark.	Texas, La., New Mexico.	Oregon, Idaho, Nev., Cal., Ariz.	Canadian Lines.		
Total Cars Owned	87,781	678,157	279,995	202,855	170,545	477,747	17,032	151,998	30,487	132,466	138,389	2,367,452	
Home Cars on Home Roads	45,757	398,077	109,183	106,201	90,037	331,625	5,810	81,180	14,498	77,743	96,956	1,357,067	
Home Cars on Foreign Roads	42,024	280,080	170,812	96,654	80,508	146,122	11,222	70,818	15,989	54,723	41,433	1,010,385	
Foreign Cars on Home Roads	46,633	282,153	194,452	71,702	66,974	179,277	8,653	67,825	24,465	53,853	40,059	1,036,046	
Total Cars on Line	92,390	680,230	303,635	177,903	157,011	510,902	14,463	149,005	38,963	131,596	137,015	2,393,113	
Excess or Deficiency	4,609	2,073	23,640	*24,952	*13,534	33,155	*2,569	*2,993	8,476	*870	*1,374	25,661	
Surplus	1,470	6,521	1,124	5,658	1,217	13,767	580	8,595	2,263	15,432	12,626	69,253	
Shortage	293	1,078	2,974	3,616	1,936	1,432	638	861	100	639	1,261	14,828	
Shop Cars—													
Home Cars in Home Shops	6,148	40,721	22,281	13,749	16,885	25,114	643	10,281	2,554	5,630	4,977	148,983	
Foreign Cars in Home Shops	940	8,072	8,397	1,979	2,140	4,577	429	2,147	817	2,293	552	32,343	
Total Cars in Shops	7,088	48,793	30,678	15,728	19,025	29,691	1,072	12,428	3,371	7,923	5,529	181,326	
Per Cent. to Total Cars Owned—													
Home Cars on Home Roads	52.13	58.70	38.99	52.35	52.79	69.40	34.11	53.41	47.55	58.69	70.06	57.32	
Total Cars on Line	102.81	100.31	108.34	87.70	92.06	106.94	84.92	96.96	127.80	99.34	99.01	101.08	
Home Cars in Home Shops	7.00	6.00	7.96	6.78	9.90	5.60	3.77	6.76	8.38	4.25	3.60	6.37	
Foreign Cars in Home Shops	.89	1.19	3.00	.97	1.26	1.02	2.52	1.30	2.68	1.73	.40	1.38	
Total Cars in Shops	7.89	7.19	10.96	7.75	11.16	6.62	6.29	8.06	11.06	5.98	4.00	7.75	

\*Denotes deficiency.



**Car Surpluses and Shortages.**

Arthur Hale, chairman of the committee on relations between railroads of the American Railway Association, in presenting statistical bulletin No. 151, giving a summary of car surpluses and shortages by groups from May 23, 1912, to September 1, 1913, says: The total surplus on September 1, 1913, was 73,576 cars; on August 15, 1913, 69,253 cars; and on August 29, 1912, 36,047 cars. Compared with the preceding period; there is an increase in the total surplus of 4,323 cars, of which 7,236 is in box, 1,197 in flat, 396 in coal, and a decrease of 4,506 in miscellaneous car surplus. The increase in box car surplus is in groups 4 (the Virginias and Carolinas) 6 (Iowa, Illinois, Wisconsin and Minnesota), 8 (Kansas, Colorado, Oklahoma, Missouri and Arkansas), 9 (Texas, Louisiana and New Mexico), 10 (Washington, Oregon, Idaho, California, Nevada and Arizona), and 11 (Canadian Lines).

The increase in flat car surplus is in all groups, except 3 (Ohio, Indiana, Michigan and Western Pennsylvania), 7 (Montana, Wyoming, Nebraska and the Dakotas), and 9 (as above). The increase in coal car surplus is in groups 3 (as above), 5 (Kentucky, Tennessee, Mississippi, Alabama, Georgia and Florida), 8, 9, 10 and 11 (as above). The decrease in miscellaneous car surplus is in all groups, except 4, 5, 6 and 7 (as above).

The total shortage on September 1, 1913, was 15,270 cars; on August 15, 1913, 14,828 cars; and on August 29, 1912, 26,297 cars. Compared with the preceding period; there is an increase in the total shortage of 442 cars, of which 1,911 is in box, 20 in flat, 340 in miscellaneous, and a decrease of 1,829 in coal car shortage. The increase in box car shortage is in all groups, except 7, 8 and 9 (as above). The increase in flat car shortage is in groups 6, 8, 10 and 11 (as above). The increase in mis-

CAR SURPLUSES AND SHORTAGES.

Date	No. of roads.	Surpluses				Total.	Shortages				Total.
		Box.	Flat.	Coal, gondola and hopper.	Other kinds.		Box.	Flat.	Coal, gondola and hopper.	Other kinds.	
Group *1.—September 1, 1913.....	7	1,010	229	5	17	1,261	159	34	185	9	387
" 2.—" 1, 1913.....	32	351	83	1,741	758	2,933	204	1	759	0	964
" 3.—" 1, 1913.....	32	1,315	249	300	1,665	3,529	1,254	200	1,328	155	2,937
" 4.—" 1, 1913.....	14	4,189	739	614	473	6,015	1,730	374	1,953	212	4,269
" 5.—" 1, 1913.....	27	510	764	131	529	1,934	850	435	864	0	2,149
" 6.—" 1, 1913.....	33	10,770	376	1,087	3,692	15,925	1,586	157	18	65	1,826
" 7.—" 1, 1913.....	4	7	10	218	218	453	62	0	0	0	62
" 8.—" 1, 1913.....	20	5,548	115	2,203	2,111	9,977	280	101	55	8	444
" 9.—" 1, 1913.....	14	1,817	274	504	314	2,909	90	0	4	11	105
" 10.—" 1, 1913.....	20	4,005	1,021	1,810	6,536	13,372	454	56	43	115	668
" 11.—" 1, 1913.....	6	13,470	288	76	1,434	15,268	958	408	0	93	1,459
Total .....	209	42,992	4,148	8,689	17,747	73,576	7,627	1,766	5,209	668	15,270

\*Group 1 is composed of New England lines; Group 2—New York, New Jersey, Delaware, Maryland and Eastern Pennsylvania lines; Group 3—Ohio, Indiana, Michigan and Western Pennsylvania lines; Group 4—West Virginia, Virginia, North and South Carolina lines; Group 5—Kentucky, Tennessee, Mississippi, Alabama, Georgia and Florida lines; Group 6—Iowa, Illinois, Wisconsin and Minnesota lines; Group 7—Montana, Wyoming, Nebraska, North Dakota and South Dakota lines; Group 8—Kansas, Colorado, Missouri, Arkansas and Oklahoma lines; Group 9—Texas, Louisiana and New Mexico lines; Group 10—Washington, Oregon, Idaho, California, Nevada and Arizona lines; Group 11—Canadian lines.

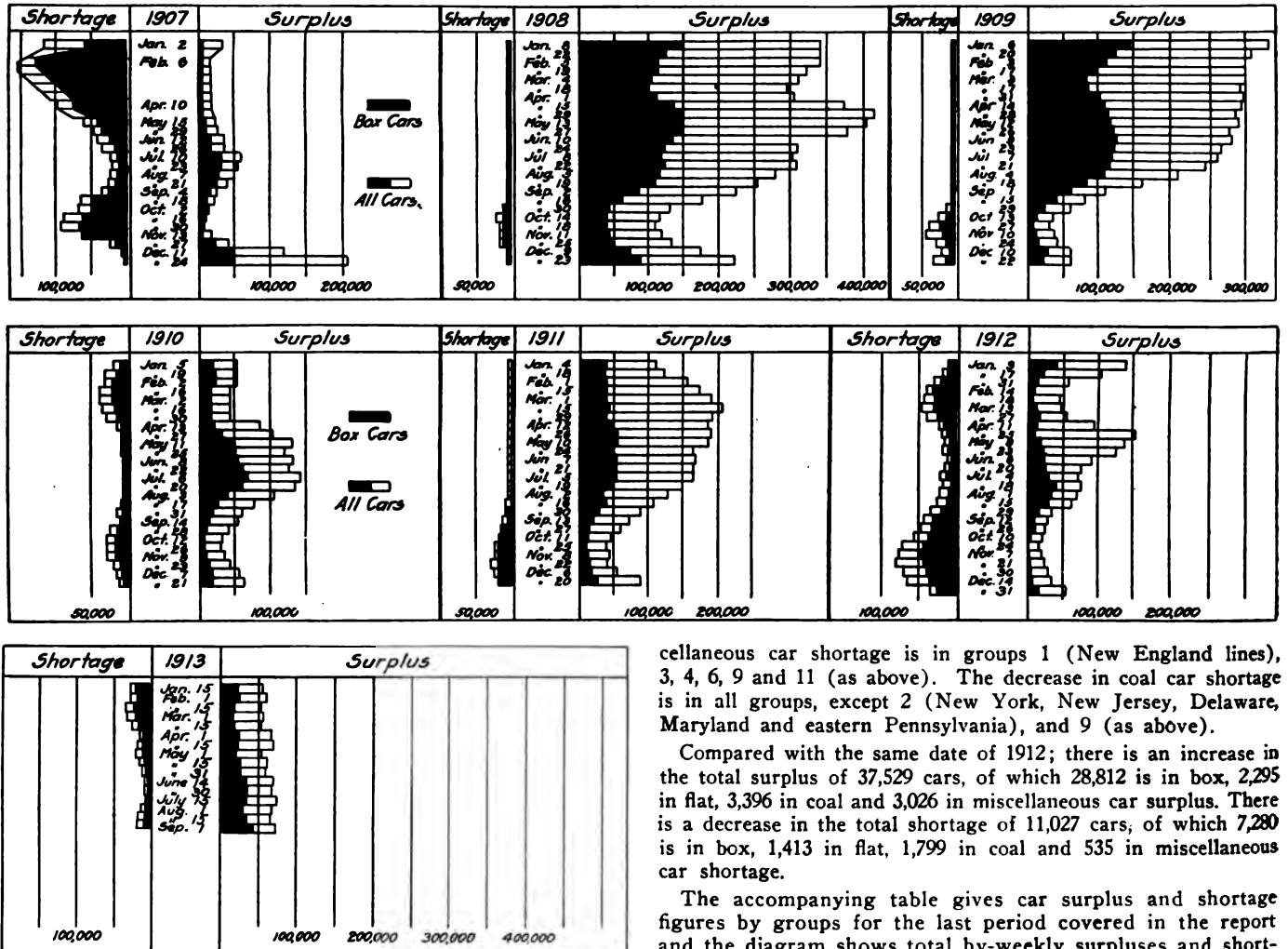

Car Surpluses and Shortages, 1907 to 1913.

cellaneous car shortage is in groups 1 (New England lines), 3, 4, 6, 9 and 11 (as above). The decrease in coal car shortage is in all groups, except 2 (New York, New Jersey, Delaware, Maryland and eastern Pennsylvania), and 9 (as above).

Compared with the same date of 1912; there is an increase in the total surplus of 37,529 cars, of which 28,812 is in box, 2,295 in flat, 3,396 in coal and 3,026 in miscellaneous car surplus. There is a decrease in the total shortage of 11,027 cars, of which 7,280 is in box, 1,413 in flat, 1,799 in coal and 535 in miscellaneous car shortage.

The accompanying table gives car surplus and shortage figures by groups for the last period covered in the report and the diagram shows total by-weekly surpluses and shortages from 1907 to 1913.

**Traffic Club of New York.**

At the regular meeting of the Traffic Club of New York, to be held September 30, J. W. Erwin will deliver an illustrated lecture entitled Through the Sunny Southland to California's Golden Gate. At this meeting the nominating committee will be selected.

The Haworth Country Club, Haworth, N. J., has extended to the members of the Traffic Club of New York the privileges of its golf course and club house for Wednesday, September 17. Prizes have been authorized and will be open to competition between members of the club only. Provision has been made for the entertainment of the ladies, including a ladies' contest.

**Summary of Revenues and Expenses of Steam Roads in June.**

The Bureau of Railway Economics' summary of revenues and expenses and comments thereon for June, 1913, are as follows: The railways whose returns are included in this summary operate 222,248 miles of line, or about 90 per cent. of the steam railway mileage in the United States. Total operating revenues for the month of June, 1913, amounted to \$253,356,489. Compared with June, 1912, the total operating revenues show an

The operating ratio for June was 70.4 per cent., which is comparable with 71.9 per cent. in May, 1913, and 68.5 per cent. in June, 1912.

The railways of the eastern district show an increase in total operating revenues per mile of line as compared with June, 1912, of 5.6 per cent., the railways of the southern district an increase of 5.4 per cent., and the railways of the western district an increase of 7.0 per cent. Operating expenses per mile increased 11.8 per cent. on the eastern railways, 7.2 per cent. on the southern railways, and 6.5 per cent. on the western railways. For the eastern railways net operating revenue per mile decreased 7.2 per cent., for the southern railways it increased 0.6 per cent., and for the western railways it increased 7.9 per cent. The increase in taxes per mile was 14.2 per cent. in the eastern district, 3.9 per cent. in the southern district, and 2.2 per cent. in the western district. Operating income per mile decreased 11.0 per cent. in the East, increased 0.5 per cent. in the South, and increased 9.3 per cent. in the West.

When the returns for the six months of the calendar year 1913 are compared with those of the corresponding months of 1912, they show an increase in total operating revenues per mile of 8.8 per cent., an increase in operating expenses per mile of 9.9 per cent., and an increase in net operating revenue per

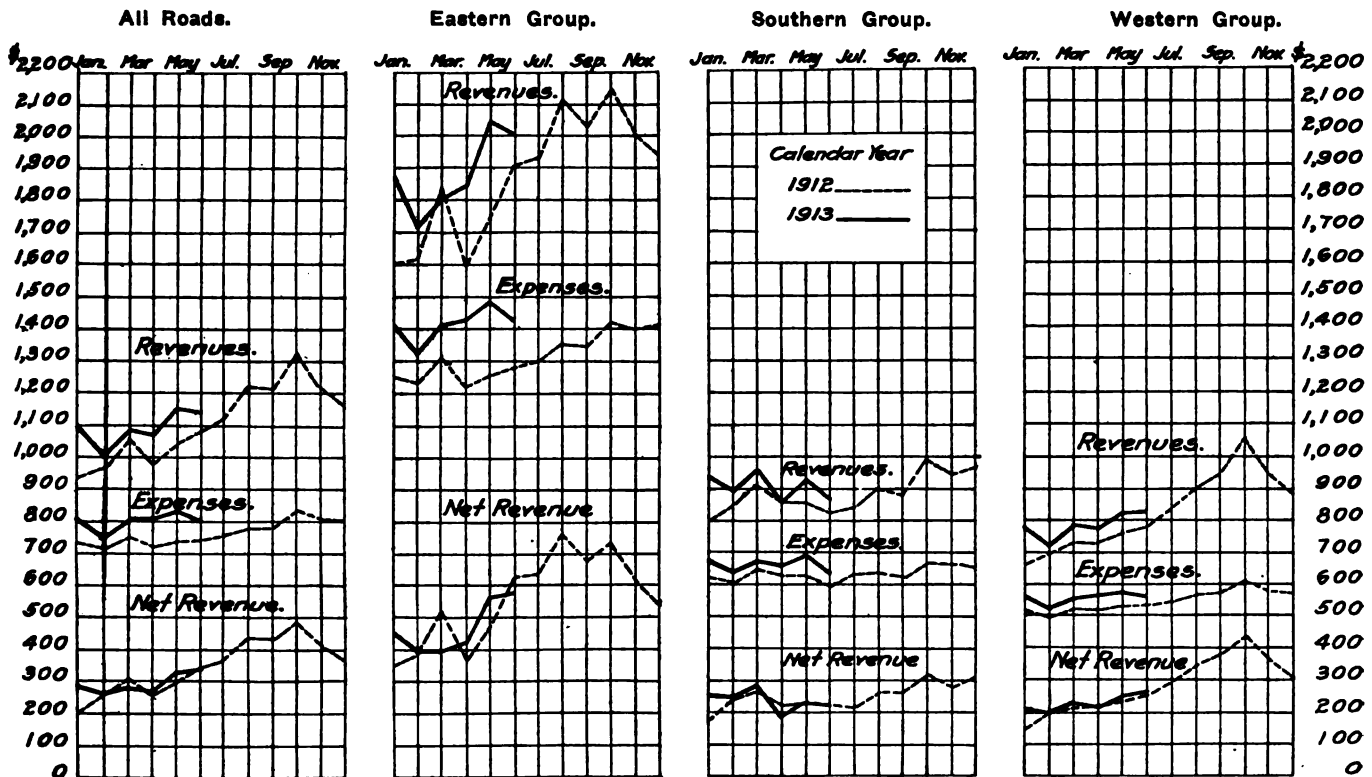

Monthly Revenues and Expenses Per Mile of Line in 1912 and 1913.

increase of \$15,992,193. These total operating revenues per mile of line averaged \$1,140 in June, 1913, and \$1,076 in June, 1912, an increase of \$64, or 5.9 per cent. Freight revenue per mile increased 6.7 per cent. and passenger revenue per mile 5.5 per cent.

Operating expenses amounted to \$178,394,784. This was \$15,744,779 more than for June, 1912. These operating expenses per mile of line averaged \$803 in June, 1913, and \$737 in June, 1912, an increase of \$65 per mile, or 8.9 per cent.

Net operating revenue amounted to \$74,961,705. This was \$247,414 more than for June, 1912, but this increase is due to the increase in mileage. Net operating revenue per mile of line averaged \$337 in June, 1913, and \$339 in June, 1912, a decrease of \$1.42 per mile, or 0.4 per cent.

Taxes for the month of June amounted to \$11,057,121, or \$50 per mile, an increase of 7.2 per cent. over June, 1912.

Operating income averaged \$287 per mile of line, and in June, 1912, \$293, thus decreasing \$5.64, or 1.9 per cent. Operating income for each mile of line for each day in June averaged \$9.57 and for June, 1912, \$9.76.

mile of 5.8 per cent. This net operating revenue per mile increased 2.5 per cent. in the eastern district as compared with the corresponding period of the previous year, increased 6.2 per cent. in the southern district, and increased 9.4 per cent. in the western district.

The diagram shows the variation in operating revenues, operating expenses and net operating revenue per mile for the separate months of the calendar year 1912 and of the calendar year 1913 to date. The following table shows the per cent. of operating revenues consumed by each class of expenses:

	PER CENT. OF TOTAL OPERATING EXPENSES.					
	June		Fiscal year ended June 30		Calendar year ended December 31	
	1913.	1912.	1913.	1912.	1912.	1911.
Maintenance of way and structures.....	14.9	14.7	13.3	12.7	12.8	12.7
Maintenance of equipment.....	16.2	15.2	16.4	15.9	16.0	15.7
Traffic expenses.....	2.2	2.2	2.0	2.1	2.0	2.1
Transportation expenses.....	34.3	33.9	35.2	35.9	35.5	35.4
General expenses.....	2.8	2.5	2.4	2.5	2.4	2.5
Total operating expenses.....	70.4	68.5	69.3	69.1	68.7	68.4

### Regulating the Cotton Export Traffic.

The Liverpool Bill of Lading Conference Committee is to assume the management and support of the central bureau to receive, inspect and record American bills of lading. Final action has been taken this summer by the European cotton interests toward the permanent organization of the bureau, with a view to affording full protection for the cotton trade against forged documents.

The practicability and the efficiency of the central bureau have been demonstrated during the last two years. The co-operation of the cotton carrying railroads has been unanimous, 116 roads having signed the agreement with the Liverpool committee and the American Bankers' Association. As a result of the constant scrutiny of the bills of lading forwarded to the central bureau and the checking up of all inaccuracies by notices to the roads, the issuing agents have become educated until greater accuracy has been obtained in the issuance of cotton bills than has ever before been approximated.

In view of the fact that European accepting bankers carry cotton drafts far longer than the discounting banks on this side, it is believed that their request for protection, addressed to the American exchange buyers, will be generally and cordially acceded to, and that the American bankers will, in turn, ask the cotton shippers to instruct the railroads to forward copies of their through bills of lading to the central bureau.

### INTERSTATE COMMERCE COMMISSION.

The commission has suspended from September 19 until March 19, Agent Countiss' tariff, which contains advances in rates on wheat in carloads from interstate points to points in Arizona and New Mexico.

Commissioner Prouty held a hearing at Chicago last week on complaints filed by a number of grain dealers against a proposed advance of one cent per 100 lbs. in rates on grain from Illinois points to New York.

The commission has suspended from September 29 until March 29, the schedules contained in certain tariffs, which proposed to advance rates on brick in carloads from Athens and other points in Ohio to Huntington, W. Va.

The commission has suspended from September 27 until March 27, the tariffs of the Southern Railway which proposed to advance rates on lumber in carloads from shipping points located on the Southern Railway in Tennessee, North and South Carolina and Georgia to Virginia cities, eastern seaboard and interior eastern points.

The commission has suspended from September 29 until March 29, the operation of the schedules in the tariffs of W. H. Hosmer, agent, which propose to increase rates applicable to the transportation of scrap iron and old rails in carloads between St. Paul and Duluth, Minn., and Chicago, St. Louis, Mo., and points taking the same rates.

The commission has suspended from September 20 until March 20, the note in Agent Leland's tariff and Agent W. A. Poteet's tariff, which would increase from 1 to 6 cents per 100 lbs. rates applicable to the transportation of potatoes and vegetables in carloads from points in Texas, Louisiana and Arkansas to Denver, Col., and points taking Denver rates.

Chairman E. E. Clark, of the Interstate Commerce Commission, held a hearing at Chicago on September 4, on a complaint instituted by the Elgin Commercial Club, alleging discrimination in the rates between Elgin, Ill., and eastern points in comparison with the rates to Aurora, Ill. Elgin is now on a 110 per cent. basis from New York, while Aurora has a 104 per cent. basis.

The commission has suspended from September 10 until January 8 the item in a supplement to the tariff of the Chicago, Milwaukee & St. Paul, which contains a proposed increase of 20 cents per gross ton, applicable to the transportation of scrap iron in carloads between Chicago and Milwaukee, Wis., the present rate being 50 cents per gross ton and the proposed rate 70 cents per gross ton.

The commission has strengthened the Board of Valuation Engineers by appointing four district engineers, and later will appoint a fifth. The four who have been appointed are: John Y. Bayless, Lynchburg, Va.; Dewitt V. Moore, consulting engineer, Indianapolis, Ind.; C. C. Witt, engineer of the Kansas Railroad Commission, and Frank Rhea, formerly with the Pennsylvania Lines, and more recently with the General Electric Company.

The commission has suspended from September 10 until January 8 the operation of an item in a supplement to Agent R. H. Countiss' tariff, which proposes to increase rates applicable to the transportation of canned apples in carloads from Portland, Ore., and other North Pacific Coast points to St. Louis, Chicago, St. Paul and points west thereof, including Wichita and Topeka, Kan. The present rate is 65 cents per 100 lbs., carload minimum weight 60,000 lbs.; the proposed rate is 85 cents per 100 lbs., carload minimum weight 40,000 lbs., an advance of 20 cents in the rate.

The commission has suspended from September 10 until January 8 the tariff of the Union Pacific, which names through rates applicable to the transportation of bananas and cocoanuts in carloads from New Orleans, Port Chalmette, Louisiana and Mobile, Alabama, to points in the states of Idaho, Oregon, Utah and Wyoming, and cancels the application of through rates in connection with the Chicago, Rock Island & Gulf, Colorado & Southern, Fort Worth & Denver City, and the Trinity & Brazos Valley, which in effect compels the movement of this traffic via Kansas City and other Missouri River gateways and thence over the lines of the Union Pacific west. Heretofore in connection with rates named in a prior issue of the above tariff, routing was provided as follows: via Texas & Pacific—Fort Worth, Texas; Fort Worth & Denver City—Sixelo, New Mexico; Colorado & Southern—Denver, Col., thence via Union Pacific and connections to destination. All other routes via Denver, Colorado, excepting the Union Pacific, have been cancelled, and it is claimed by protestants that the cancelled routes are most desirable for this traffic and the application of combination rates via such routes would result in material increases in rates.

### STATE COMMISSIONS.

The California Railroad Commission has issued an order to the Pullman Company to appear on November 19 and explain its rules and regulations, especially those governing porters and their conditions of employment.

Everett E. Stone, of Springfield, has been appointed a member of the Massachusetts Public Service Commission, succeeding George P. Lawrence, former Congressman, who resigned. The appointment is for a three-year term. Mr. Stone was formerly division engineer of the Boston & Albany, and had been mayor of Springfield.

A hearing was held on September 8 at Chicago before the Illinois Railroad and Warehouse Commission on a complaint of the Chicago Board of Trade against the Atchison, Topeka & Santa Fe, Chicago & Alton, Chicago & Eastern Illinois, Illinois Central and Wabash, because these lines have declined to enter into the Chicago reciprocal switching agreement under which switching charges on cars of Illinois grain in the Chicago switching district are absorbed by the other roads.

The Public Service Commission of Missouri has issued an order prohibiting railways from charging more than two cents a mile for passengers who pay fare in cash on trains. The railways, however, will be allowed to collect a penalty of 10 cents from passengers paying on the train, the amount to be refunded on application at the general offices. The railways have been charging three cents a mile for fares paid on the train. The commission has also issued an order that on shipments over two or more lines of railway mileage rates shall be figured from point of origin to final destination and based on the state rate for the entire distance, instead of a combination of the rates prescribed for each line; such rates are not to cover switching charges at points of origin or destination performed by lines other than those performing the road service.

# Railway Officers.

## Executive, Financial and Legal Officers.

C. A. Chapman has been appointed auditor of the Nevada Copper Belt, with headquarters at Salt Lake City, Utah, succeeding F. J. Sullivan, transferred. (See Traffic Officers.)

W. F. Bull, chief clerk to the chairman of the executive committee of the Southern Pacific, at New York, has been appointed assistant secretary of the Southern Pacific and the Louisiana Western, with headquarters at New York, succeeding Joseph Hallen, resigned.

## Operating Officers.

Fred W. Souerby has been appointed supervisor of demurrage and weighing of the Illinois Central and the Yazoo & Mississippi Valley, with headquarters at Chicago. Effective September 10.

Otto Holstein, operating manager of the Central Railway of Peru, with office at Lima, Peru, has been appointed superintendent of transportation of the Guayaquil & Quito, with office at Huigra, Ecuador, South America.

G. A. Stokes, superintendent of the Toronto terminals of the Grand Trunk, at Toronto, Ont., has been appointed division agent and W. H. Farrell, superintendent of freight service at Montreal, Que., has been appointed superintendent of the Toronto terminals, succeeding Mr. Stokes.

C. L. French, superintendent of the Connellsville division of the Baltimore & Ohio, at Connellsville, Pa., has been appointed assistant general superintendent of the Pittsburgh system, with headquarters at Pittsburgh, Pa. O. L. Eaton, assistant superintendent of the Connellsville division, at Somerset, has been appointed superintendent with headquarters at Connellsville, and S. C. Wolfersberger, supervisor of transportation of the Pittsburgh system, has been appointed assistant superintendent, with headquarters at Somerset.

James Paul Stevens, whose appointment as general superintendent of the Virginia general division of the Chesapeake & Ohio, with headquarters at Richmond, Va., has been announced in these columns, was born on December 28, 1885, at Peru, Ind., and was educated in the common schools. He began railway work in January, 1901, on the Chesapeake & Ohio, as clerk to the chief dispatcher at Hinton, W. Va., and has been in the continuous service of that road ever since. He was later copy operator in the dispatcher's office and extra dispatcher at Richmond, Va. In January, 1904, he was appointed assistant trainmaster on the Cincinnati division at Covington, Ky.; the following May he became chief dispatcher, and was promoted to assistant superintendent in February, 1907, becoming superintendent in January, 1908, of the same division, with headquarters at Covington. He was appointed general superintendent of the Kentucky general division in May, 1910, with headquarters at Covington, which position he held at the time of his recent appointment as general superintendent of the Virginia general division of the same road, as above noted.

To reduce the territory covered by the general superintendent the New York, New Haven & Hartford will hereafter be operated in two grand divisions. All the lines east of Willimantic, Conn., and New London, and comprising the Boston, Providence and Old Colony divisions will be known as the Eastern Grand division. All the lines west of those points, comprising the Midland, Western and the present Shore Line divisions, will hereafter be known as the Western Grand division. The present Shore Line division is divided and a new division covering the main line west of New Haven and the Danbury and New Canaan branches has been created to be known as the New York division, with headquarters at Harlem River, N. Y. The Shore Line division will cover the lines between New Haven and Springfield, and New Haven and New London, including the Northampton branch. John A. Droege, superintendent of the Shore Line division at New Haven, Conn., has been appointed general superintendent in charge of the operation of the Western Grand division, with office at New Haven. A portrait of Mr. Droege, and a sketch of his railway career were published in the *Railway Age Gazette* of December 20, 1912, page 1231.

Clayton N. Woodward, general superintendent at Boston, Mass., has been appointed general superintendent in charge of the Eastern Grand division, with office at South Station, Boston. Charles H. Motsett, freight trainmaster, at Harlem River, N. Y., has been appointed superintendent of the New York division, with office at Harlem River. William H. Foster, superintendent of the Old Colony division at Taunton, Mass., has been appointed superintendent of the Shore Line division, with office at New Haven. Harry C. Oviatt, assistant mechanical superintendent at New Haven, has been appointed superintendent of the Old Colony division, with office at Taunton, Mass. The office of James O. Halliday, master of transportation at New Haven, has been abolished, and he has been appointed assistant to the general manager. Donald French Stevens, trainmaster of the Third division of the Shore Line at New Haven, succeeds Mr. Motsett as trainmaster at Harlem River, and John Flick, assistant trainmaster, succeeds Mr. Stevens.

C. L. French, who has been appointed assistant general superintendent of the Pittsburgh system of the Baltimore & Ohio, with headquarters at Pittsburgh, Pa., was born on December 27,



C. L. French.

1866, at Cumberland, Md., and graduated from Allegheny County High School. He began railway work on October 1, 1883, as a messenger in the train despatcher's office on the Cumberland division of the Baltimore & Ohio, and has been in the continuous service of that road ever since. He was later appointed operator and then train despatcher. On June 1, 1899, he was made chief despatcher, which position he held until August 1, 1902, when he was appointed assistant trainmaster. He then became trainmaster at Cumberland, Md., remaining in that position until April, 1910, when he was made

superintendent of the Connellsville division, which position he held at the time of his recent appointment as assistant general superintendent of the Pittsburgh system of the same road.

## Traffic Officers.

C. C. Womble has been appointed soliciting freight agent of the Gulf, Colorado & Santa Fe at Waco, Tex.

The headquarters of S. H. Dare, general western freight agent of the Atlantic Coast Line at Cincinnati, Ohio, have been transferred to Chicago.

F. B. Choate, general agent of the freight department of the Union Pacific at Denver, Colo., has been appointed assistant general freight agent at that place.

L. B. Dickie, contracting freight agent of the Chicago, Milwaukee & St. Paul, has been appointed contracting freight agent of the Kansas City, Mexico & Orient at Chicago.

L. B. Limming, commercial freight agent of the Baltimore & Ohio at Omaha, Neb., has been appointed traveling freight agent at that point. A. J. Anderson succeeds Mr. Limming.

W. J. Faherty, westbound contracting freight agent of the Wabash at Chicago, has been transferred to New York as contracting freight agent. A. D. Heaphey succeeds Mr. Faherty.

F. J. Sullivan, auditor of the Nevada Copper Belt, at Salt Lake City, Utah, has been appointed traffic manager and superintendent, with headquarters at Mason, Nev., succeeding G. M. Fraser, deceased.

The agency of the Erie Despatch at Cedar Rapids, Iowa, was abolished, on September 1, and the territory heretofore covered by that agency is now under the jurisdiction of D. L. Porch, agent at Davenport, Iowa.

V. A. Blewett, traveling freight agent of the Rock Island Lines at Los Angeles, Cal., has been appointed commercial agent, with headquarters at Los Angeles, succeeding B. F. Coons, resigned to engage in other business.

M. J. Dooley, freight agent of the Sunset Central Lines of the Southern Pacific, at Shreveport, La., has been appointed general agent at that place, succeeding A. W. Cheesman, resigned, whose title was division freight and passenger agent. The latter office is abolished.

F. J. Burke, division freight agent of the International & Great Northern, at Dallas, Tex., has been appointed assistant general freight agent in charge of solicitation, with headquarters at Dallas. Guy A. Deuel, division freight agent at El Paso, Tex., succeeds Mr. Burke. D. L. Ray, commercial agent at Paris, Tex., takes the place of Mr. Deuel. A. B. Waldron, traveling freight agent, with headquarters at Ft. Worth, Tex., succeeds Mr. Ray, and C. B. Fox succeeds Mr. Waldron.

G. K. Caldwell, assistant general freight agent of the Southern Railway at Atlanta, Ga., has been appointed general freight agent, with headquarters at Washington, D. C., and B. G. Brown has been appointed assistant general freight agent, with office at Atlanta, Ga.; E. C. Rankin has been appointed traveling freight agent, with office at Columbia, S. C., and A. C. Izard, freight soliciting agent at Rock Hill, S. C., having resigned to engage in other business, that agency has been abolished.

W. H. Underwood, whose appointment as assistant to the passenger traffic manager of the New York Central Lines West, with headquarters at Chicago, has already been announced in these columns, was born May 6, 1858, at Rochester, N. Y., and began railway work in 1874. He was a clerk in the office of the assistant general superintendent of the Michigan Central and clerk in the city ticket office of the Canada Southern at Detroit, Mich., until July, 1878, when he was made city passenger and ticket agent of the Wabash in that city. In April, 1883, he was appointed western passenger agent of the Michigan Central at Chicago, and four years later he became general eastern passenger agent at Buffalo, N. Y. He was promoted to assistant general passenger agent of the latter road in April, 1905, which position he held until his recent appointment as assistant to the passenger traffic manager of the New York Central Lines West, as above noted.

George Kearsley Caldwell, who has been appointed general freight agent of the Southern Railway, with headquarters at Washington, D. C., was educated in the grammar schools, and began railway work in 1894, with the East Tennessee, Virginia & Georgia, remaining with that road until it was taken over by the Southern Railway. He then held various clerical positions in the general freight office of the Southern until April 1, 1903, when he became chief rate clerk in the general freight department of the Central of Georgia. From November, 1905, to February, 1907, he was chief clerk in the general freight department of the Southern Railway, and then was chief clerk to the freight traffic manager until September, 1908, when he became chief clerk to the vice-president in charge of traffic of the same road. In June, 1911, he was promoted to division freight agent at Columbus, S. C., and on September 1, 1912, became assistant general freight agent at Atlanta, Ga., which position he held at the time of his recent appointment as general freight agent of the same road as above noted.

The jurisdiction of L. D. Knowles, assistant general freight agent of the Missouri Pacific and the St. Louis, Iron Mountain & Southern, at Omaha, Neb., has been extended over the Denver & Rio Grande and the Western Pacific. Dan Jacobs, assistant general freight and passenger agent of the St. Louis, Iron Mountain & Southern at Alexandria, La., has been appointed assistant general freight agent of that road, and the Missouri Pacific, Denver & Rio Grande and Western Pacific at that place. R. M. McWilliams, assistant general freight agent of the Missouri Pacific and St. Louis, Iron Mountain & Southern at Little Rock, Ark., will also have jurisdiction over the Denver & Rio Grande and Western Pacific. The jurisdiction of J. B. Trimble, heretofore general eastern freight agent of the Missouri Pacific-Iron Mountain system at New York, has been extended over the Denver & Rio Grande and the Western Pacific. The following general agents of freight department

have jurisdiction over the four roads mentioned above: W. C. Staley, Chicago; W. H. Reed, New Orleans, La.; J. O. Barkley, St. Joseph, Mo.; C. C. McCarthy, Pittsburgh, Pa.; F. C. Gifford, Kansas City, Mo.; J. L. Amos, St. Louis, Mo.; L. M. White, Detroit, Mich.; C. B. Brownell, Natchez, Miss.; C. S. Blackman, Hot Springs, Ark.; A. S. Edmonds, Philadelphia, Pa.; T. A. Helm, Dallas, Tex. J. E. Woodfin is made assistant general agent of the freight department at Ft. Worth, Tex. H. S. Drysdale is appointed New England freight agent at Boston, Mass. J. D. Kenworthy, assistant general freight agent of the Denver & Rio Grande at Pueblo, Colo., will hereafter have jurisdiction also over the Western Pacific, Missouri Pacific and St. Louis, Iron Mountain & Southern, and the following are appointed general agents, freight department, of all four roads: J. E. Courtney, Denver, Colo.; J. J. Kavanaugh, Salt Lake City, Utah; W. B. Kenney, Grand Junction, Colo.; S. M. Brown, Leadville, Colo.; J. M. Norton, Seattle, Wash.; E. S. Blair, Los Angeles, Cal.; W. C. McBride, Portland, Oregon. In the passenger traffic department the representation of the four roads is as follows: General agents passenger department, Ellis Farnsworth, Chicago; J. M. Cloyes, Kansas City; J. A. Steltenkamp, Cincinnati; J. M. Griffin, St. Louis; T. F. Godfrey, Omaha, Neb.; C. K. Bothwell, Wichita, Kan. Garland Tobin is made southwestern passenger agent at San Antonio, Tex.; J. O. Barkley, general agent at St. Joseph, Mo.; Wm. E. Hoyt, general eastern passenger agent at New York, and H. A. Cooper, district passenger agent at Joplin, Mo.

#### Engineering and Rolling Stock Officers.

I. H. Farmer has been appointed right of way engineer of the Seaboard Air Line, with office at Portsmouth, Va., succeeding G. H. Earp, promoted.

R. F. Williams has been appointed division engineer of the San Antonio division of the International & Great Northern, with headquarters at San Antonio, Tex.

J. J. Hess, division roadmaster of the Great Northern at Whitefish, Mont., has been appointed assistant engineer maintenance of way, with office at St. Paul, Minn.

W. R. Powrie has been appointed district engineer of the Chicago, Milwaukee & St. Paul, with office at Minneapolis, Minn., in place of M. D. Rhame, retired on account of ill health. Effective September 17.

George W. Robb, master mechanic of the Grand Trunk Pacific, at Transcona, Man., has been appointed superintendent of motive power, with headquarters at Transcona, and his former position has been abolished.

R. W. Schulze, who recently resigned as general car foreman of the Gulf, Colorado & Santa Fe, at Cleburne, Tex., has been appointed superintendent of the car department of the St. Louis & San Francisco, with headquarters at Springfield, Mo.

C. J. Stewart, master mechanic of the New York, New Haven & Hartford, at South Boston, Mass., has been appointed assistant mechanical superintendent, succeeding H. C. Oviatt, promoted, and G. A. Moriarty, master mechanic at Providence, R. I., succeeds Mr. Stewart.

S. L. Wonson has been appointed assistant bridge engineer of the Missouri Pacific, with office at St. Louis, Mo., and G. B. Bagley has been appointed assistant engineer, with office at Kansas City, succeeding G. W. Payne, transferred to the valuation department at St. Louis.

W. O. Houston, division engineer of the Michigan Central at St. Thomas, Ont., has been appointed division engineer at Jackson, Mich., with jurisdiction over the Grand Rapids, South Haven and Allegan divisions and the main line from the westerly limits of the Detroit yards to the easterly limits of the Niles yard. S. D. Williams, Jr., acting division engineer at Niles, Mich., succeeds Mr. Houston.

C. H. Reid, master mechanic of the Western division of the New York, New Haven & Hartford, at Waterbury, Conn., has been appointed master mechanic of the Providence division, with office at Providence, R. I. F. W. Nelson, general road foreman of engines at New Haven, Conn., has been appointed master mechanic of the Western division, with office at Waterbury, Conn.

J. McCabe, master mechanic at Harlem River, N. Y., has been appointed master mechanic of the New York division, with office at Harlem River. E. W. Alling, master mechanic of the Old Colony division, at Taunton, Mass., has been appointed master mechanic of the Shore Line division, with office at New Haven, succeeding W. S. Clarkson, resigned, and J. H. Daley, road foreman of engines of the Shore Line division, has been appointed master mechanic of the Old Colony division, with office at Taunton, Mass.

**Purchasing Officers.**

R. A. Klock has been appointed general tie and timber agent for the Intercolonial and the Prince Edward Island railways, with headquarters at Moncton, N. B.

D. Downing, heretofore general storekeeper of the Wheeling & Lake Erie, at Ironville, Ohio, has been appointed general storekeeper of the Chicago & Alton, with headquarters at Bloomington, Ill., succeeding C. B. Foster, resigned.

Floyd Kirkland Mays, who was recently appointed purchasing agent in addition to his duties as treasurer of the Atlanta, Birmingham & Atlantic, with headquarters at Atlanta, Ga., was



F K Mays.

born on December 10, 1884, at South Boston, Va., and was educated in the common schools at Danville. He began railway work on April 2, 1903, as a stenographer in the office of the yardmaster of the Southern Railway at Danville, and in February, 1905, became stenographer in the office of the general agent and superintendent of the Southern Railway and the Chesapeake Steamship Company at Norfolk. On June 15, 1909, he was appointed secretary to the general manager of the Norfolk & Southern at Norfolk, and in August, 1912, became chief clerk to the general manager of the

Atlanta, Birmingham & Atlantic at Atlanta, Ga. He was appointed treasurer for the receivers of the A. B. & A. on February 1, 1913, and now becomes also purchasing agent of the same road, also the Georgia Terminal Company and the Alabama Terminal Railroad, with headquarters at Atlanta.

**Special Officers.**

Maurice A. Welsh has been appointed chief special agent of the Waterloo, Cedar Falls & Northern, with office at Waterloo, Iowa. H. R. Parker succeeds Mr. Welsh as special agent at Waterloo.

**OBITUARY.**

Judge J. McD. Trimble, formerly general counsel of the Kansas City, Mexico & Orient, died at his home in Kansas City, Mo., on September 13, aged 62 years.

**THE SECOND SIMPLON TUNNEL.**—A correspondent writes: The boring of the second gallery of the Simplon tunnel is advancing steadily, 1,367 workmen being employed in the tunnel itself, and 816 outside it—in all on an average 2,183 per day. The work is in the hands of the Swiss Federal Railways, and is being supervised by Chief Engineer Rothpletz, who was also the chief engineer of the Loetschberg tunnel. Originally there was talk of handing over the contract for the work to a German firm, whose tender was lower than that of any Swiss firm, but owing to the outcry raised by the Swiss engineers, and more or less by the Swiss in general, the Federal railways decided to be their own contractors.

**Equipment and Supplies.**

**LOCOMOTIVE BUILDING.**

THE CHICAGO & ILLINOIS MIDLAND is in the market for two 100-ton consolidation locomotives.

THE NORFOLK & WESTERN has ordered 24 electric locomotives from the Baldwin Locomotive Works and the Westinghouse Electric & Manufacturing Company.

THE MOND NICKEL COMPANY, Coniston, Ont., has ordered 1 mogul locomotive from the American Locomotive Company. The dimensions of the cylinders will be 20 in. x 26 in., the diameter of the driving wheels will be 50 in., and the total weight in working order will be 156,000 lbs.

**CAR BUILDING.**

THE PHILADELPHIA & READING is reported to be in the market for about 50 passenger coaches.

THE ERIE is in the market for 7 postal cars, and is having 1,800 freight cars rebuilt by the American Car & Foundry Company.

THE NORTHERN PACIFIC, mentioned last week as being in the market for 40 refrigerator cars and 12 baggage cars, is also in the market for 31 coaches and 16 mail cars.

THE GREAT NORTHERN has ordered 125 passenger cars from the Pullman Company and the Barney & Smith Car Company. The Pullman company will build the postal cars and the Barney & Smith Car Company will build all the other cars.

**IRON AND STEEL.**

THE MISSOURI, KANSAS & TEXAS has ordered 7,500 tons of rails from the Pennsylvania Steel Company.

THE SOUTHERN PACIFIC has ordered 15,000 tons of rails from the Tennessee Coal, Iron & Railroad Company.

**GENERAL CONDITIONS IN STEEL.**—Conditions in the steel industry continue to be very much the same. Consumers in general are showing no tendency to place heavy orders in the immediate future, but the railroads are beginning to enter the market again with large orders for 1914 requirements. It is expected that a large volume of orders from this source will be placed during the next month. The mills are operating at about the same rate of capacity, namely, 90 per cent.

**NEW LOCOMOTIVE ENGINE.**—We were much gratified a day or two since by a visit to the machine shop of William B. James, No. 40 Eldridge street, where we saw in operation on a short temporary railway in his yard, a locomotive engine constructed upon an entirely different plan from any that we have before seen. No part of the engine except the boiler and smoke pipe is over 39 in. above the surface of the rails, and it is so constructed that no fire falls from the furnace nor is a spark even seen to rise from the smoke pipe. The cylinders are on the outside and below the top of the wheels. It is to carry its own fuel and water, and the fire is driven by a bellows worked by the machinery, and therefore is always in proportion to the velocity. It is estimated to weigh, with the supply of water and fuel on board, 3½ tons, and to run from thirty to forty miles an hour. Its power is equal to 16 horses. To give some idea of the ease with which it is controlled when under way, we saw it run a distance of about 50 ft. forward and backwards eight times in 63 seconds, including stops. Mr. James placed it upon wheels without flanges a few days since and ran it over the pavements on Third avenue to Yorkville, about five miles, took breakfast and then returned to the city. The performance, he said, was altogether satisfactory. He has it in contemplation to take it to Baltimore in a few days to give it a fair trial. It will be found, we predict, an ingenious and valuable addition to those already in successful operation on their railroads. We wish Mr. James success, for his plan is called the American.—*From the American Railroad Journal, October 20, 1912.*

## Supply Trade News.

The American Machinery Company, manufacturers' agents for machinery and supplies, Salt Lake City, Utah, desires to receive catalogs and prices of machinery and supplies.

Charles N. Replogle, superintendent of the Cambria Steel Company, has been made works manager of the Ralston Steel Car Company, New York, with office in Columbus, Ohio.

The Isthmian Canal Commission will receive bids until October 6 on miscellaneous supplies, including motor driven centrifugal pumps, traveling cranes, air compressors, etc. Circular No. 796.

The American Locomotive Company has received an order for one rotary snow plow from the Corbin Coal & Coke Company, Spokane, Wash. This plow will have 17 in. x 22 in. cylinders, and a 10 ft. 7 in. cut scoop wheel.

The United Engineering & Construction Company, Schofield building, Cleveland, Ohio, desires to receive catalogs from manufacturers of material and equipment covering civil, mechanical and architectural engineering.

Page Harris, superintendent of transportation of the Texas & Pacific, has been made vice-president of the National Lumber & Creosote Company, Texarkana, Ark., with office in Houston, Tex., succeeding G. F. Cotter, resigned.

Beaudry & Company, Inc., Boston, Mass., has perfected a direct connected motor drive for its Beaudry Champion and Beaudry Peerless power hammers, and is now arranging to carry a complete stock of motor driven hammers in addition to belt-driven hammers.

The H. W. Johns-Manville Company, New York, has opened a branch office at Galveston, Tex., where a warehouse will be maintained, from which the stock will be distributed throughout Texas. This firm has two other branch offices in Texas, one at Houston and one at Dallas.

The Beaver Dam Malleable Iron Company, Beaver Dam, Wis., on Tuesday, September 16, filed a voluntary petition in bankruptcy in the federal court at Milwaukee. Liabilities are placed at \$500,000, and assets at \$650,000. Ernest E. Smythe, of Milwaukee, was appointed receiver.

G. S. Turner, for the last four years connected with the Crane Company, has been made second vice-president of the Chas. R. Long, Jr., Company, manufacturers of railway paints. Mr. Turner will also represent Harry Vissering & Co., having been made second vice-president of that company. His office will be at 20 West Jackson boulevard, Chicago, Ill. Mr. Turner was for more than ten years associated with the Southern Railway in the capacity of general foreman, superintendent of shops and general inspector of equipment.

Asbestos Protective metal, made by the Asbestos Protective Metal Company, Beaver Falls, Pa., has been standardized by the Pennsylvania Railroad for the enclosing of all buildings on its lines using sheet metal roofing or siding, except those of a most temporary character. This product is made for the Pennsylvania Railroad in special colors to match the standard color scheme of that company. Recent orders from the Pennsylvania Railroad include a freight station at Harrisburg, freight sheds at Uniontown, dock buildings at Baltimore, and pier 29, North river, New York.

### TRADE PUBLICATIONS.

**CARBON STEEL.**—The Carbon Steel Company, Pittsburgh, Pa., has published a small booklet describing its various kinds of steels, and showing the uses for which each is best adapted.

**FUEL OIL.**—Tate-Jones & Company, Inc., Pittsburgh, Pa., has published circular No. 142, entitled Fuel Oil Data. This circular tells of the advantages of fuel oil over coal for a variety of purposes.

**SIGNALING AND TRAIN DESPATCHING.**—The Northey-Simmen Signal Company, Ltd., Indianapolis, Ind., has published an il-

lustrated folder describing the Simmen system of railway signaling and train despatching.

**WELDING.**—The Westinghouse Electric & Manufacturing Company, Pittsburgh, Pa., has published an illustrated booklet entitled Electric Arc Welding Processes, which is a reprint of an article by C. B. Auel, in the *American Machinist*.

**SECOND HAND EQUIPMENT.**—Booth & Flinn, Ltd., Pittsburgh, Pa., have published bulletin G enumerating their variety of second hand railway equipment on hand, including boilers, cars, excavators, hoists, locomotives, locomotive cranes, rails, etc. Prices are given.

**TRACK APPLIANCES.**—The Railroad Supply Company, Chicago, has issued the sixth edition of its pocket booklet on "Track," which describes and illustrates a large number of appliances handled by this company for use in contract work, together with a number of interesting tables and specifications of use to the track man.

**LOCOMOTIVE FURNACE.**—The American Arch Company, New York, has published an illustrated booklet entitled The Locomotive Furnace, giving the fundamental principles of combustion, and describing the Gaines locomotive furnace and telling what it will do. The booklet includes instructions for the care of these furnaces.

**WATERPROOFING.**—The Barrett Manufacturing Company, New York, has published an illustrated booklet entitled The Largest Terminal in the World and How It Was Waterproofed, which tells how and why the Grand Central Terminal, New York, was waterproofed with Barrett Specification pitch and Barrett Specification tarred felt.

**LOCOMOTIVE CRANES.**—The Brown Hoisting Machinery Company, Cleveland, Ohio, has published catalog K, entitled Brownhoist Locomotive cranes with Grab Buckets. This catalog gives a general description of Brownhoist locomotive cranes of various capacities, and shows by illustrations how the cranes are used in connection with Brownhoist patented grab buckets.

**NORTHERN PACIFIC.**—The passenger department of this company has published a very attractive illustrated folder describing the scenes along the route of the trip through the Yellowstone Park taken by the members of the American Association of Passenger Agents after their convention, which was held in St. Paul, September 7-9. Members left St. Paul on September 9 and returned on September 18.

**STEEL CUTTING.**—The Davis-Bournonville Company, Jersey City, N. J., has published catalog bulletin No. 1, on the Oxygraph, a machine devised for cutting steel in regular forms, following the lines of a drawing placed on a tracing table. It is of pantagraph design and is motor propelled so that it can be driven at uniform, predetermined speed best calculated for the thickness of the metal to be cut. This arrangement permits the cutting to be done not only in sharp curves but at right or acute angles.

**EAST INDIAN TRACKMEN.**—These laborers work patiently, punctually, and efficiently, with due regard to their natural limitations, under the most trying climatic conditions. They are mostly small landowners; their fields yield enough, with little attention, to satisfy their very modest wants and those of their families, while the railway pay enables them to procure some highly-esteemed little luxuries, whether in food, in raiment, or in the personal adornments of their female relatives and dependents. Besides this, in many places they are allowed to grow castor oil and other paying plants on the embankment slopes. In consequence of their contented state of mind—especially under kind and tactful inspectors—strikes are unknown. The climate in which they work ranges from the icy cold of the winter months in the northwest to the terrific scorching winds of the summers in the same regions; from the continuous steaming damp heat of the south to the rainless deserts of the west. The traffic continues more or less all the year round; there are no ice-bound periods when the road cannot be touched, and, moreover, by far the majority of the lines are single track, involving incessant care and watchfulness.

## Railway Construction.

**BIRMINGHAM-TUSCALOOSA RAILWAY & UTILITIES COMPANY (Electric).**—This company, which was organized to build a low-grade line from Birmingham, Ala., southwest via Bessemer to Tuscaloosa, 54 miles, has located the line. The maximum grades will be 7/10 of 1 per cent., and the maximum curvature 4½ deg. A contract for building the line was given some time ago to the Tidewater Construction Company, Birmingham. F. E. Calkins, president, New York. C. R. Carter and W. S. Adams are incorporators. (April 18, p. 925.)

**BLACK MOUNTAIN.**—This road is now in operation between Black Mountain Junction, N. C., where a connection is made with the Carolina, Clinchfield & Ohio and Pensacola, 20.6 miles.

**BUTTE, WISDOM & PACIFIC.**—It is understood that this company, which was recently incorporated in Montana, will begin construction work about October 1. The plans call for building from Divide, Mont., up the Big Hole river in Silverbow, Beaverhead and Deerlodge counties, Mont. J. D. Brown, Helena; C. M. McCoy and L. P. Benedict, Butte, are interested. (August 22, p. 353.)

**CAROLINA & YADKIN RIVER.**—This road has been extended from Thomasville, N. C., northeast to High Point, 6 miles. (March 7, p. 459.)

**DETROIT, BAY CITY & WESTERN.**—This company, which operates a line from Bay City, Mich., east to Wilmot, 40 miles, is building an extension from Wilmot east to Sandusky, 21 miles. Surveys have been made and right of way has been secured for building a further extension from Sandusky southeast to Port Huron, about 40 miles.

**GRAND TRUNK PACIFIC.**—Train service has been extended on the Mirror & Calgary subdivision of the Prairie division from Trochu, Alta., south to Beiseker, 41.6 miles, and the Mountain division has been extended from New Hazleton, B. C., south to Morristown, 23.9 miles.

**GREENVILLE, BLUE RIDGE & NORTHERN.**—Plans are being made to build from a point on the Houston & Texas Central at Anna, Tex., southeast to Greenville, it is said. The line is to be extended eventually to the piney woods section of East Texas. Between Anna and Blue Ridge 12 miles of track has already been laid. W. N. Harrison, Greenville, is back of the project.

**HENRYETTA INTERURBAN.**—An officer writes that the company plans to begin work at once on a line from Henryetta, Okla., east to Dewar, thence north to Coalton, about 10 miles. Two surveys have been made and the final route will be selected at once. On the completion of this line the company expects to build west from Henryetta to a connection with the Atchison, Topeka & Santa Fe at Sparks, about 50 miles, or to a connection with the Fort Smith & Western at Okemah, about 20 miles. The company expects to develop a large coal and oil tonnage, as the line will traverse a rich coal and oil section. Contracts for building the line have not yet been let. C. H. Kellogg, president, Henryetta. (September 5, p. 436.)

**HOUSTON & TEXAS CENTRAL.**—The cut-off from Giddings, Tex., northeast via Lebau, Dime Box, Deenville, Caldwell, and Cooks Point, to Stone City, 39.77 miles, has been completed and was opened for business on September 10. (May 9, p. 1052.)

**ILLINOIS TRACTION.**—This company has under consideration the question of building an extension, it is said, from Clinton, Ill., northeast via Bellflower, Saybrook, Anchor and Fairbury to Kankakee.

**IDAHO ROADS (Electric).**—According to press reports, financial arrangements are being made to build from Alexander, Idaho, south via Ogden canyon, to Ogden, Utah, about 125 miles. F. W. Crockett, Logan, Idaho, may be addressed.

**LOUISIANA & ARKANSAS.**—The Jena branch has been extended from Jena, La., east to Jonesville, 13.8 miles.

**L'OUTRE RAILROAD.**—Incorporated in Louisiana with \$250,000 capital by residents of Monroe, to build from a point in Union

parish, northeast through Ouachita and Morehouse parishes in Louisiana, and Chicot and Desha counties, in Arkansas, to Arkansas City, about 60 miles. F. B. Pierce, president; F. P. Stubbs, Jr., vice-president; A. Wolff, secretary, and L. Bradt, treasurer, Monroe.

**MANATAWNY RAILROAD.**—An officer writes that contracts have been given to the Highley Construction Company, Pottstown, Pa., to build from connections with the Philadelphia & Reading and the Pennsylvania Railroad at Stowe, Montgomery county, Pa., west two miles to Douglasville, Berks county, thence north, via Amityville to Manatawny iron mines, 8 miles. Grading has been finished on three miles, but no track has yet been laid. The work calls for the excavation of 17,000 cu. yds. a mile. There will be two bridges, each to be 150 ft. long, and two or three temporary trestles. The company expects to develop a traffic in iron ore, limestone and general freight and farm products. M. J. Person, president, A. E. Lehman, chief engineer, 506 Walnut street, Philadelphia. (November 29, p. 1063.)

**MICHIGAN CENTRAL.**—The Allegan division has been extended from Homer, Mich., to Moscow.

**NEW ALBANY & FRENCH LICK VALLEY TRACTION.**—Organized in Indiana, it is said, to build from New Albany, Ind., west via Mooreville, Greenville, Palmyra, Hardinsburg and Paoli to West Baden Springs and French Lick Springs, 60 miles, with a four-mile branch from Mooreville via Georgetown and Lanesville to Corydon. Surveys have been made. C. S. Hernley, Newcastle, and G. W. Schindler, New Albany, may be addressed.

**NEW YORK SUBWAYS.**—Bids for the construction of section No. 2, located in Greenwich street, West Broadway and Park Place, in the borough of Manhattan, of the Seventh avenue subway are wanted by the New York Public Service Commission, First district, on October 1. The Seventh avenue extension is to be built from the present subway at Times Square, in the borough of Manhattan, down Seventh avenue and Varick street, West Broadway, Park Place, Beekman street, William street and Old Slip, to and under the East river to a connection with the present subway in the borough of Brooklyn. There will also be a two-track extension from Park Place south to the Battery. North of Park Place it will be a four-track line. When completed, the extension will be operated under the Dual System contracts by the Interborough Rapid Transit Company.

The New York Public Service Commission, First district, has authorized the execution of a contract for the completion of the two additional tracks in the Centre street subway in the borough of Manhattan, connecting the Williamsburg bridge with the station in the basement of the Municipal building at a cost of about \$500,000. Two tracks on this line are already in operation. The New York Municipal Railway Corporation, which is to do the work for the city, expects to begin the work at once and to complete it in 18 months.

**NORTH LOUISIANA (Electric).**—This company is planning to build a 110-mile line, it is said, from Shreveport, La., east via Minden, Homer, and Arizona to Monroe. A. B. Blevins, president, Jefferson, La.

**OIL BELT.**—This company, building a line from Charleston, Ill., south via Casey, Bellair, Oblong, Hardinville, Bridgeport, Linn and Patton to Mt. Carmel, about 100 miles, has opened for operation the section from Oblong south to Bridgeport, 25 miles. Connections are made at Oblong with the Illinois Central and at Bridgeport with the Baltimore & Ohio Southwestern. (February 14, p. 313.)

**OKLAHOMA & TEXAS CENTRAL.**—Organized in Oklahoma to build from Coffeyville, Kan., south to Fort Worth, Tex., about 300 miles. An officer is quoted as saying that grading contracts will be let soon, and that construction work will be started in about 90 days on the section from Tulsa, Okla., north to Coffeyville. W. E. Hawley, president, Tulsa, Okla.; C. H. Cleveland, first vice-president, Skiatook; E. E. Edge, second vice-president, Cleveland, and C. L. Hounker, secretary and treasurer, Tulsa.

**OREGON SHORT LINE.**—The Teton branch of the Montana division has been extended from Driggs, Idaho, to Victor, 8 miles.



**PACIFIC GREAT EASTERN.**—An officer of this company, which started work some time ago on a line from Vancouver, B. C., north to the Grand Trunk Pacific at Fort George, about 350 miles, writes that about 170 miles are under construction, and a force of about 4,000 men are now at work. The company has bought 65 acres of land as a site for shops and yards on the north shore of Burrard Inlet, in North Vancouver. (April 11, p. 863.)

**SEATTLE, PORT ANGELES & LAKE CRESCENT.**—An officer writes that work is now under way from a point near Oak Bay, Wash., west via Irondale, Chimacum valley, Sequim, Dungeness valley and Port Angeles to the Lyre river, and past Lake Crescent into the Olympic timber district. Contracts have been given to the Newman-McHugh Construction Company; Rowan & Anderson and A. R. Swanson, of Port Williams, Wash.; Dunn & Hogan, and Ferch & Gass, of Port Crescent; Cervien & Miller; Swan Peterson; J. E. Anderson; Dennis O'Rourke and H. M. Munger of Port Angeles. The company expects to develop a traffic in forest products and general merchandise. C. J. Erickson, president, Seattle, and C. C. Donovan, chief engineer, Port Angeles. (March 28, p. 779.)

**SULTAN VALLEY.**—Incorporated in the state of Washington with \$500,000 capital, to build a 30-mile line from Sultan, Snohomish county, Wash., into Sultan basin and the mining district. The incorporators include J. Wigren, F. N. Thayer, and J. C. Davis, Chicago; N. B. Jones, of Sultan, Wash., and E. H. Guie, Seattle.

**UNION PACIFIC.**—The North Flat branch of the Wyoming division has been extended from Gering, Neb., to Haig, 6.7 miles.

#### RAILWAY STRUCTURES.

**LOS ANGELES, CAL.**—The Southern Pacific has practically completed arrangements with the city for the construction of a new passenger station which will cost approximately \$700,000.

**MCADAM JUNCTION, N. B.**—The new shops now being built by the Canadian Pacific at McAdam Junction include an erecting shop 70 ft. x 129 ft., containing six engine pits, and a machine shop 80 ft. x 129 ft. Both structures are to be of concrete and brick, with steel frames. The work, which will cost over \$100,000, is already well advanced. (July 11, p. 78.)

**OGDEN, UTAH.**—The Denver & Rio Grande has let a contract for the construction of a freight terminal to cost about \$35,000, to the Continental Contract Company of Ogden. The terminal will include a two story office building and a freight shed 196 ft. long.

**SPOKANE, WASH.**—A contract has been given to Grant, Smith & Company, Seattle, Wash., for putting up a union station, at Trent street, Spokane, to be used jointly by the Oregon-Washington Railroad & Navigation Company and the Chicago, Milwaukee & St. Paul. The contract includes erecting the steel work on a 1,400-ft. elevated track approach to the station, and putting up umbrella sheds. The station is to be of steel, brick, and stone construction, 52 ft. x 300 ft., and four stories high. The work is to be started at once. The steel for the approach and the station is being furnished by the American Bridge Company.

**VANCOUVER, B. C.**—See Pacific Great Eastern under Railway Construction.

**PUKOW-SINYANG RAILWAY CONCESSION.**—A British engineer has been appointed to carry out preliminary surveys of the Pukow-Sinyang railway in China. The concession for the line was granted to the British Chinese Corporation in 1898, but the construction has been repeatedly deferred. The line will cost approximately \$15,000,000, and the preliminary agreement provides as regards security that the terms shall be similar to those of the Shanghai-Nanking Railway, involving the mortgage of the line, foreign accountancy, etc. The surveys will occupy a year. The projected line will link the Peking-Hankow and the Tientsin-Pukow lines, the junction with the latter being effected considerably north of Pukow, and it will constitute a valuable feeder to both railways.

## Railway Financial News.

**BOSTON & MAINE.**—Howard Elliott has been elected a director, succeeding Charles S. Mellen.

**BROOKLYN RAPID TRANSIT.**—See editorial comments on the annual report in another column.

**CHICAGO GREAT WESTERN.**—This company has asked the Public Service Commission of Missouri for approval of an issue of \$3,116,000 bonds and an equal amount of 4 per cent. preferred stock to represent the purchase of bonds of the Wisconsin, Minnesota & Pacific.

**LAKE SHORE & MICHIGAN SOUTHERN.**—White, Weld & Company, Kissel, Kinnicutt & Company, and Harris, Forbes & Company, all of New York, are offering \$11,800,000 Cleveland Short Line first mortgage 4½ per cent. bonds of 1911-1961, guaranteed principal and interest by the Lake Shore & Michigan Southern. The bonds are offered at 95¼, yielding 4.75 per cent. on the investment. These bonds are secured by a first mortgage on the new double track belt line railroad which has been built to give the Lake Shore & Michigan Southern two additional tracks for its main line through the city of Cleveland. The cost of this property was \$13,201,531. The road intersects every railroad entering Cleveland and was built with a maximum 0.3 per cent. grade, with no grade crossings.

**LEHIGH VALLEY.**—See editorial comments on the annual report in another column.

**NATIONAL RAILWAYS OF MEXICO.**—The interest payments, aggregating \$1,500,000, on the general mortgage 4 per cent. guaranteed bonds and on the first consolidated mortgage 4 per cent. bonds are, it is understood, to be paid when due, October 1, the Mexican government having agreed to extend any help necessary to the company.

**NEW YORK CENTRAL & HUDSON RIVER.**—The United States Senate has ordered the Interstate Commerce Commission to make a formal investigation of the New York Central's proposal to consolidate the Lake Shore & Michigan Southern with the lines east of Buffalo, and to make a new refunding mortgage. See editorial comments in our issue of July 11, page 41.

J. P. Morgan & Co., New York, have bought from the company and sold to the public \$5,000,000 5 per cent. one-year notes, the selling price to the public being 5½ per cent.

**ST. LOUIS & SAN FRANCISCO.**—The receivers have asked Judge Sanborn for authorization to pay about \$3,316,000 principal and interest on certain issues of bonds and notes now due. The date for the hearing has not as yet been fixed.

**ST. LOUIS SOUTHWESTERN.**—A quarterly dividend of 1 per cent. has been declared on the non-cumulative preferred stock, payable October 15. This reduces the annual rate paid in 1912 and the first three-quarters of 1913 from 5 per cent. to 4 per cent.

**SOUTHERN PACIFIC.**—This company has made arrangements for the sale of \$7,130,000 4½ per cent. equipment trust certificates subject to the authorization of the California railroad commission.

**SMYRNA-DARDANELLES RAILROAD.**—The council of state of the Ottoman Empire has approved the concession to a French syndicate, L'Omnium d'Entreprises de Paris, for the construction and operation of a railroad from Smyrna to the Dardanelles with a branch line from Ezine to Kara-Bigha. The principal and most significant terms of the concession are as follows: The line is to be narrow gage and its total length approximately 310 miles. The main line between the Dardanelles and Smyrna will follow the coast line passing through or near Aivadjik, Adramit, Burhanie, Aivali, Dikili, and Ali Agha. The branch line between Ezine and Kara-Bigha will include the towns of Bairamitch, Djare-Payar, and Baighnilar. The concession has been granted for a period of ninety-nine years.

## ANNUAL REPORTS.

## BROOKLYN RAPID TRANSIT CO.—REPORT OF THE BOARD OF DIRECTORS TO THE STOCKHOLDERS FOR YEAR ENDING JUNE 30, 1913.

85 CLINTON STREET,  
BROOKLYN, N. Y., August 5, 1913.

The financial results of the system for the year ending June 30, 1913, show:

An increase in gross earnings from operation of \$925,737.57, or 3.99 per cent.;

An increase in operating expenses of \$221,396.56, or 1.76 per cent.;

An increase in surplus from operation of \$785,705.40, or 21.17 per cent.;

An increase in reserves for insurance and depreciation of \$298,758.87;

A decrease in bills payable of \$1,400,000.

The net surplus of the system for the year was \$4,504,411.56.

Dividends declared during the year aggregated \$2,440,770.35. The rate was 1½ per cent. quarterly, except for the last quarter, when it was increased to 1½ per cent.

Certain adjustments of the profit and loss account, including the setting aside of a special reserve of \$50,000 and the charging off of \$60,522.83 to supercession and depreciation, left the surplus of the combined system as of June 30, 1913, \$7,904,606.63, as against \$5,863,812.80 at the close of the fiscal year 1912.

The attention of stockholders is called elsewhere in this report to the gradual conversion into capital stock of the Brooklyn Rapid Transit Company's Refunding Mortgage Four Per Cent. Gold Bonds, thus increasing the amount of capital stock outstanding, which on June 30, 1913, was \$49,078,000. The opportunity for conversion expires on July 1, 1914.

COMPARATIVE STATEMENT OF THE RESULTS OF THE OPERATIONS OF THE BROOKLYN RAPID TRANSIT SYSTEM FOR YEARS ENDING JUNE 30, 1913, AND 1912.

	1913.	1912.	Increase or Decrease.
Gross Earnings from Operation	\$24,152,288.09	23,226,550.52	+ 925,737.57
Operating Expenses	12,833,455.89	12,612,059.33	+ 221,396.56
<b>Net Earnings from Operation</b>	<b>11,318,832.20</b>	<b>10,614,491.19</b>	<b>+ 704,341.01</b>
Income from Other Sources	339,946.88	317,991.12	+ 21,955.76
<b>Total Income</b>	<b>11,658,779.08</b>	<b>10,932,482.31</b>	<b>+ 726,296.77</b>
Less Taxes and Fixed Charges	7,161,851.41	7,221,260.04	— 59,408.63
<b>Net Income</b>	<b>4,496,927.67</b>	<b>3,711,222.27</b>	<b>+ 785,705.40</b>
Profit from Real Estate disposed of (a) and other Miscellaneous Items (b)	**7,483.89	20,036.75	— 12,552.86
<b>Total Surplus for Year</b>	<b>4,504,411.56</b>	<b>3,731,259.02</b>	<b>+ 773,152.54</b>
Surplus at Beginning of Year	5,863,812.80	5,427,394.54	+ 436,418.26
<b>Total</b>	<b>10,368,224.36</b>	<b>9,158,653.56</b>	<b>+ 1,209,570.80</b>
Of this amount there has been appropriated:			
Accounts written off	28,513.60	2,972.91	+ 25,540.69
Adjustment of Taxes prior years	*116,255.73	28,543.65	— 144,799.38
Adjustment of Expenses prior years	66.68	14,460.60	— 14,393.92
Supercession and Depreciation	60,522.83	9,012.95	+ 51,509.88
Special Reserve	50,000.00	1,000,000.00	— 950,000.00
Dividend on B. R. T. Co.'s Stock outstanding	2,440,770.35	2,239,850.65	+ 200,919.70
<b>Total Appropriations</b>	<b>2,463,617.73</b>	<b>3,294,840.76</b>	<b>— 831,223.03</b>
<b>Balance Sheet Surplus</b>	<b>\$7,904,606.63</b>	<b>\$5,863,812.80</b>	<b>+ 2,040,793.83</b>

\*Credit. \*\*1913 (b) only.

RAPID TRANSIT EXPANSION—AGREEMENTS WITH THE CITY.

During the Company's fiscal year the long negotiations with the City for the expansion of rapid transit (referred to in the last two preceding reports) were finally consummated in the contracts of March 19, 1913, between The City of New York and New York Municipal Railway Corporation, which was incorporated on September 27, 1912, for the purpose of carrying out this Company's part in the so-called Dual System.

These contracts were four in number, and covered substantially the following obligations:

1. The City agreed to construct at its expense three rapid transit railroads, namely:

(a) The Broadway-Fourth Avenue Line, comprising generally in Manhattan the Broadway-59th Street line, the Canal Street connection with Manhattan Bridge, the Centre Street Loop with its extension through Nassau and Broad Streets, and a tunnel under the East River, and in Brooklyn the Fourth Avenue subway from Manhattan Bridge to 86th Street, with branches to Coney Island via 38th Street and New Utrecht Avenue, and to a connection with the Brighton Beach railroad at Malbone Street via Flatbush Avenue.

(b) The Culver Line, constituting in effect another branch of the Fourth Avenue subway to Coney Island via Gravesend Avenue.

(c) The Fourteenth Street-Eastern Line, beginning at 6th Avenue, Manhattan, and extending under 14th Street and the East River to North Seventh Street, Brooklyn, and thence to a connection with the elevated railroads at East New York.

2. The Company agreed to equip the above named railroads, and to contribute towards the cost of construction thereof the sum of \$13,500,000 in addition to the cost of a connection between the Broadway and Canal

Street subways; also at its own expense to construct and equip certain elevated railroad extensions, one to Jamaica via Jamaica Avenue, and the other to Lefferts Avenue, Queens, via Liberty Avenue, and certain additional tracks upon the present elevated railroad system, and to provide for certain connections and reconstruction of the railroads and equipment of the New York Consolidated Railroad Co.

The estimated cost of construction to the City is \$100,500,000; of construction and equipment to the Company, \$65,000,000, besides the contribution of existing rapid transit railroads.

3. The lines to be constructed by the City are to be leased to the Company for a period of 49 years from January 1, 1917 (with provision for recapture by the City after ten years), and are to be operated by the Lessee in connection with the existing railroads of the New York Consolidated Railroad Co. (as enlarged and extended) as one system, and for a single fare.

There will be approximately 293 miles of track in the enlarged system (including trackage rights over the Astoria and Corona, Queens, lines enjoyed mutually with the Interborough Rapid Transit Co.), of which approximately 133 miles will be owned by the City.

Under the terms of the lease the annual net revenue remaining after operating expenses, taxes and provision for depreciation, is to be applied in the following order:

1. To the Lessee \$3,500,000 as representing the net earnings of the existing railroads which are to form part of the new rapid transit system. Out of this reservation the Lessee is to pay interest charges on capital investments prior to March 19, 1913, in the existing railroads.

2. To the Lessee six per cent. on its new investment in construction and equipment prior to the beginning of permanent operation, and thereafter interest and one per cent. sinking fund.

3. To the City interest and one per cent. sinking fund on its investment in cost of construction.

Any surplus remaining, after making provision for a moderate contingent reserve fund, is to be divided equally between the Lessee and the City.

Prior to the execution of the contracts with the City, and pursuant to the predetermined arrangement, the companies owning the existing railroads which are to form part of the new rapid transit system, namely, the Brooklyn Union Elevated Railroad Co., the Canarsie Railroad Co. and the Sea Beach Railway Co., were duly consolidated into the New York Consolidated Railroad Co., and subsequently the latter company took from the New York Municipal Railway Corporation an assignment of the operating provisions of the City contracts assumed by that corporation, so that the New York Consolidated Railroad Co. will be the operator of the new system. It also has acquired all the capital stock of the New York Municipal Railway Corporation, with the right and obligation to take any which may hereafter be issued, and has guaranteed the principal and interest of the latter company's funded debt. The money necessary for construction and equipment, however, will be provided by the New York Municipal Railway Corporation, and for this purpose it has mortgaged its agreement and lease with the City and all its other property, now or hereafter acquired, to secure \$100,000,000 of its Five Per Cent. Gold Bonds. Its authorized capital stock is \$2,000,000, of which \$100,000 has been issued and is outstanding.

Thus it will be seen that all the surplus earnings of the new rapid transit system, except that portion which is paid over to the City, will accrue to the New York Consolidated Railroad Co., of whose stock the Brooklyn Rapid Transit Co. and one of its constituent companies own over 96 per cent.

In order that funds necessary for carrying out the contracts with the City might be promptly available and because of the parent company's superior credit, the Brooklyn Rapid Transit Co., as set forth in last year's annual report, prior to the formation of the new company and to the execution of the City contracts, arranged with the Central Trust Co. of New York, Messrs. Kuhn, Loeb & Co., and Messrs. Kidder, Peabody & Co. for the sale of \$40,000,000 of its Six-year Secured Gold Notes on a Six Per Cent. basis, less a commission of one per cent. These notes were delivered on October 1, 1912. They date from July 1, 1912, bear interest at the rate of five per cent. per annum, and are secured by \$10,000,000 Refunding Mortgage Four Per Cent. Bonds of Brooklyn Rapid Transit Co. and \$40,000,000 of New York Municipal Railway Corporation's First Mortgage Five Per Cent. Gold Bonds, the latter bonds having been acquired at 97 and accrued interest with the proceeds of the notes, and with additional funds provided by the Brooklyn Rapid Transit Co. The notes are convertible, at the option of the holder, par for par, prior to January 1, 1916, into the New York Municipal Railway Corporation's bonds, which, in addition to the guarantee of New York Consolidated Railroad Co. previously referred to, bear the Brooklyn Rapid Transit Co.'s assumption of payment—principal and interest.

Stockholders are to be congratulated, therefore, that so large a part of the funds called for by the City contracts, and all that will probably be required during the first three years, are in hand and were secured upon more favorable terms than would be possible under existing financial conditions. The construction work is now under way and will be prosecuted as rapidly as conditions permit.

In the meanwhile, a portion of the Broadway-Fourth Avenue Line, namely, two tracks in the Centre Street Loop, was placed in operation on August 4, 1913, and, under the provisions of the City contract as to temporary operation, the pooling of earnings then became effective and the distribution of revenue will be made substantially as described above.

The status of the surface railroad lines in the Company's system remains unaffected by the new contracts with the City.

ADDITIONS, IMPROVEMENTS AND MAINTENANCE.

The maintenance of way and structure and of equipment during the year absorbed \$3,880,331.71 of the system's revenue, an increase in charges over the preceding year of \$88,485.21.

The construction charges aggregated \$5,400,819.67, of which the larger amount, as shown in the table elsewhere presented, was in connection with the rapid transit contracts entered into with The City of New York on March 19, 1913.

SURFACE LINES.

Two short extensions of surface lines were constructed during the year, namely, on Malbone Street from a connection with the Kingston Avenue line to a connection with the Nostrand Avenue line, and on Sixteenth Avenue from 58th Street to the Sea Beach line near 63rd Street. Additional trackage thus constructed was 1.19 miles measured as double track.

13.43 miles (including .14 miles on the Brooklyn Bridge) of single-track were relaid with a standard type of heavy grooved rail. 122,565 square yards of improved pavement (14.57 miles of street) were

laid between tracks and rails, and in addition the city was reimbursed for approximately 32,150 square yards of pavement laid adjacent to the outer rails of tracks. A much larger volume of work has been arranged for the ensuing fiscal year.

Six electrically operated switches, three side tracks, and five cross-overs were constructed during the year, and seventy-five pieces of special work were renewed.

Portions of the trestle on the Flushing line across Flushing Creek were rebuilt and defective piles renewed on the bridge across Coney Island Creek on the Culver line.

The Church Avenue Tunnel under Ocean Parkway was reconstructed and widened and iron bar overhead work substituted for trolley wire.

**ELEVATED LINES.**

47,045 feet of rail (representing approximately 4.45 miles of single track) and 3,540 feet of steel guard rail were renewed. 19,300 cross ties, 28,582 feet of timber guard rail, 69,424 feet of foot-walk, and 2,473 track-bonds were renewed.

Three and one-half miles of elevated structure were repainted. This included sections of the Fifth Avenue line from 34th Street to 67th Street, Flatbush Avenue from Fulton Street to Fifth Avenue, Fulton Street from Fulton Ferry to Hudson Avenue, and Myrtle Avenue from Hudson Avenue to Grand Avenue.

The steel work of sixteen highway bridges across the Brighton Beach line was cleaned and repainted.

Waiting rooms were constructed at the Ocean Parkway station of the Brighton Beach line and at Van Siclen station of the Culver line.

Additional platform facilities were constructed at the Consumers' Park Station of the Brighton Beach line and entrances to Washington Avenue provided for the better accommodation of traffic due to the opening of the new ball grounds.

**POWER STATIONS.**

The 20,000 K. W. Turbo Generator Unit contracted for last year has been delivered and is now being erected, the installation of the auxiliary apparatus being practically completed.

A temporary sub-station, made necessary by the operation of the Centre Street Loop, has been erected at Centre and Walker Streets, Manhattan, and equipped with two 1,000 K. W. Rotary Converters and the necessary auxiliary apparatus.

**TRANSMISSION SYSTEM.**

66.77 miles of trolley wire were renewed and 2.06 miles erected in connection with extensions, side tracks, etc.

1,523 trolley poles were painted, 191 poles reinforced, 690 poles reset, 250 poles replaced, and 112 new poles erected.

1.56 miles of feeder were installed in underground conduits and 3.75 miles of overhead feeders removed.

**CAR EQUIPMENT.**

100 surface cars of the center entrance type were ordered and 11 had been placed in service at the close of the fiscal year.

105 cars of miscellaneous type—freight, mail, work cars, etc.—were equipped with wheel guards.

2 snow plows were added.

57 pairs of modern design Maximum Traction Trucks replaced an equal number of equipments of less efficient type.

1,507 surface passenger cars and 82 freight cars were overhauled, repaired and varnished.

900 elevated passenger cars were overhauled, repainted and varnished, and five additional lights installed in each of 32 motor cars.

The brake equipment of 317 elevated motor cars was improved by the installation of interlocking devices.

Additional machinery was installed in the various shops.

**MISCELLANEOUS.**

The construction of the Classon Avenue Relief Sewer by the City will involve temporary abandonment of tracks and re-routing of cars on certain lines, causing some inconvenience to patrons of such lines during the ensuing year and a very large expense to the companies.

The East New York Employees' Club House was altered to provide increased facilities and equipped with refrigerating plant and cold storage room, and additional restaurant and kitchen utensils and restaurant and club room facilities have been installed and improved at other locations.

The sprinkler equipment in the 58th Street Depot contracted for last year was completed.

Numerous minor improvements have been made, particularly in repair shops and depots, for the better protection of companies' properties against damage by fire.

300 new fire-proof metal lockers have been installed at various depots and shops.

New equipment for the construction and repair of tracks has been purchased, consisting of three rail grinders, two electric cranes, one electric rail welding machine, one electric bonding apparatus, two electric track drills, two gasoline concrete mixers, and one rail cutting machine.

**MEDICAL INSPECTION BUREAU.**

In December, 1912, the Medical Inspection Bureau was organized, in charge of a Chief Inspecting Physician and Assistant, for the examination and care of employees of the Transportation Department. The effectiveness of the work was reflected in a very material decrease in the number of working days lost by employees on account of sickness compared with the corresponding period of the year previous. The Bureau is supported by the company and the service is rendered without charge to employees, and through an arrangement with various druggists the employees are enabled to procure medicines at small cost.

**INCREASE IN WAGES.**

Just prior to the close of the fiscal year and effective July 4, 1913, a general increase was announced in wages of employees, benefitting about six thousand men in the Transportation Department. The increases varied according to the length of service and record of efficiency, and ranged from four to fifteen per cent.

**ACQUISITION OF THE CONEY ISLAND & BROOKLYN R. R. CO.**

An opportunity was presented during the fiscal year to acquire upwards of two-thirds of the capital stock of the Coney Island & Brooklyn Railroad Company, and application to take this stock was made on March 29, 1913, to the Public Service Commission for the First District by the Coney Island

& Gravesend Railway Company, one of the constituent companies of the Brooklyn Rapid Transit Company. No action has as yet been taken by the Commission upon the application.

**SAFETY CAMPAIGN.**

On March 1, 1913, the Brooklyn Rapid Transit Co., in co-operation with the American Museum of Safety, undertook a Children's Safety Campaign of six months in the public schools of Brooklyn. This work, authorized by the Board of Education of the City, has been continued with great success through the last four months of the regular sessions of the schools ending in June, and is now going on in the summer schools and playgrounds throughout the territory in which the company operates.

The safety crusade is conducted in the public schools by means of lectures delivered to the children in the class rooms and assembly halls, these lectures being illustrated by small models of B. R. T. trolley cars and supplemented by story pamphlets and the distribution of safety buttons. Three such pamphlets have been used in the regular sessions of the schools. The school lectures have also been conducted in many of the parochial institutions of Brooklyn, where the same model cars and pamphlets have been employed in impressing upon the children the safety lessons.

In many of the schools, the teachers have given most encouraging co-operation by such undertakings as the organization of safety patrols to guard the children in crossing streets going to and from school, and in the arrangement of safety days, on which, in several instances, an entire day has been given up to safety demonstrations, with lectures, recitations by the children, and safety plays in which some children would impersonate passengers, some conductors and motormen, and others pedestrians and the drivers of vehicles in the streets. In one school, where a publication is issued monthly, one number of this publication was devoted especially to the safety work, and cuts were printed of the B. R. T. safety wagon, the modern cars, and other paraphernalia of the safety crusade.

The safety work has adapted itself very successfully to the instruction in the summer schools and summer playgrounds maintained in various parts of the Borough of Brooklyn, particularly in the congested districts. The summer school and playground instruction being necessarily of a more informal character than that of the regular school session, the lecturers in the safety campaign have been able to come very intimately into contact with the children and in many instances, with their parents.

Specially for this summer school work, a set of drawings was prepared graphically illustrating accident conditions due to carelessness of passengers or pedestrians, which drawings have been employed with evident appreciation by the children and the teachers. All told, in the campaign of the last six months, approximately 300,000 safety buttons have been distributed, and 600,000 leaflets. The lecturers have visited practically all of the public schools in Brooklyn, 170 in number, and many parochial schools. The summer instruction is covering 13 summer schools and over 30 playgrounds.

It is anticipated that the school crusade this year will be a beginning for even more extended safety instruction in the schools with possible outside co-operation from organizations or committees. Evidences of appreciation by the children and their parents have come in from many sources, and the work has the cordial endorsement of the school authorities of the city.

Respectfully submitted,

T. S. WILLIAMS,  
President.

**COMPARATIVE SUMMARY OF OPERATIONS**

FOR YEARS ENDING JUNE 30, 1913, AND 1912.

REVENUE FROM OPERATION	1913.	1912.	Inc. + or Dec. —	Per Cent.
Transportation .....	\$23,865,260.22	22,940,021.32	+916,238.90	3.99
Miscellaneous .....	287,027.87	277,529.20	+ 9,498.67	3.42
<b>Total .....</b>	<b>\$24,152,288.09</b>	<b>23,226,550.52</b>	<b>+925,737.57</b>	<b>3.99</b>
<b>OPERATING EXPENSES</b>				
Maintenance of Way and Structure .....	\$1,678,124.06	1,636,712.56	+ 41,411.50	2.53
Maintenance of Equipment .....	2,202,207.65	2,155,133.94	+ 47,073.71	2.18
Operation of Power Plant .....	1,421,122.81	1,404,160.19	+ 16,962.62	1.21
Operation of Cars—Trainmen's Wages .....	4,062,795.93	3,863,699.74	+199,096.19	5.15
Operation of Cars—Other Expenses .....	1,572,661.48	1,586,973.72	— 14,312.24	.90
Damages .....	605,091.77	681,440.81	— 76,349.04	11.20
Legal Expenses in Connection with Damages .....	217,211.43	231,975.02	— 14,763.59	6.36
General Law Expenses....	61,933.58	65,195.52	— 3,261.94	5.00
Other General Expenses....	746,870.84	733,394.19	+ 13,576.65	1.85
Freight and Mail Expenses .....	264,324.49	252,762.54	+ 11,561.95	4.57
American Railway Traffic Co.—Expenses .....	1,111.85	711.10	+ 400.75	56.40
<b>Total .....</b>	<b>\$12,833,455.89</b>	<b>12,612,059.33</b>	<b>+221,396.56</b>	<b>1.76</b>
<b>NET REVENUE FROM OPERATION .....</b>	<b>\$11,318,832.20</b>	<b>10,614,491.19</b>	<b>+704,341.01</b>	<b>6.64</b>
<b>INCOME FROM OTHER SOURCES .....</b>	<b>339,946.88</b>	<b>317,991.12</b>	<b>+ 21,955.76</b>	<b>6.90</b>
<b>TOTAL INCOME .....</b>	<b>\$11,658,779.08</b>	<b>10,932,482.31</b>	<b>+726,296.77</b>	<b>6.64</b>
<b>DEDUCTIONS</b>				
Taxes .....	\$1,750,083.07	1,775,041.42	— 24,958.35	1.41
Interest and Rentals (Net) .....	5,411,768.34	5,446,218.62	— 34,450.28	.63
<b>Total .....</b>	<b>\$7,161,851.41</b>	<b>7,221,260.04</b>	<b>— 59,408.68</b>	<b>.82</b>
<b>SURPLUS .....</b>	<b>\$4,496,927.67</b>	<b>\$3,711,222.27</b>	<b>+785,705.40</b>	<b>21.17</b>

COMPARATIVE CONSOLIDATED BALANCE SHEET.  
ASSETS—JUNE 30, 1913.

<b>COST OF ROAD AND EQUIPMENT:</b>	
Properties owned in whole or in part by Brooklyn Rapid Transit Company.....	\$126,544,983.30
Construction Expenditures, Constituent Companies, not yet funded.....	927,668.86
	<u>\$127,472,652.16</u>
Bonds of Brooklyn City Railroad Company Deposited with Trustee of Brooklyn Rapid Transit Company Refunding 4% Bonds .....	600,000.00
Advances to Leased Companies, account of Additions and Betterments to Leased Lines .....	11,440,521.27
Securities deposited with Trustee to guarantee performance of terms of Lease of Brooklyn City Railroad .....	4,153,945.00
(Comprising \$2,000,000 Brooklyn, Queens Co. & Suburban Railroad Co. 1st Mortgage 5% Bonds at 103 1/4, \$25,000 Brooklyn Rapid Transit 5% Bonds at par, \$1,627,000 Brooklyn City Railroad Consolidated 5's at 103 1/4, \$125,000 Brooklyn City Railroad Refunding 4's at par, and \$250,000 B. R. T. Co. 1st Refg. 4% Bonds at par.)	
Capital Expenditures account of Subway and Rapid Transit Lines .....	4,267,379.39
	<u>\$147,934,497.82</u>
<b>MATERIALS AND SUPPLIES.....</b>	<b>1,079,872.49</b>
<b>CURRENT ASSETS:</b>	
Accounts Receivable .....	\$881,150.79
Investments .....	165,166.08
Cash on Hand and in Bank.....	2,118,304.55
	<u>3,164,621.42</u>
In addition there are the following Treasury Bonds and Stocks available for sale not included in Assets or Liabilities:	
Brooklyn Rapid Transit Company, Capital Stock, par value .....	\$64,782.02
Bonds of Brooklyn Rapid Transit and Constituent Companies, par value.....	57,111,500.00
	<u>57,176,282.02</u>
<b>CASH FUND FOR CONSTRUCTION AND EQUIPMENT OF SUBWAYS AND RAPID TRANSIT LINES.....</b>	<b>35,483,220.19</b>
<b>SPECIAL DEPOSITS OF SECURITIES AND CASH:</b>	
Insurance Reserve Investments.....	\$420,690.43
City of New York .....	1,000,000.00
	<u>1,420,690.43</u>
<b>PREPAID ACCOUNTS .....</b>	<b>194,910.81</b>
	<u>\$189,277,813.16</u>

LIABILITIES—JUNE 30, 1913.

<b>CAPITAL STOCK:</b>	
Brooklyn Rapid Transit Company—	
Capital Stock .....	\$49,078,000.00
Less—In Treasury.....	64,782.02
	<u>\$49,013,217.98</u>
Constituent Companies—	
Shares not owned by the Brooklyn Rapid Transit System.....	824,008.98
	<u>\$49,837,226.96</u>
<b>FUNDED DEBT:</b>	
Issued—	
Brooklyn Rapid Transit Company.....	53,885,000.00
The Brooklyn Heights R. R. Co.....	250,000.00
The Nassau Electric Railroad Co.....	15,000,040.00
Brooklyn, Queens Co. and Suburban R. R. Co.....	6,624,000.00
New York Consolidated R. R. Co.....	23,650,000.00
Brooklyn Union Elevated R. R. Co.....	
Sea Beach Railway Company.....	
B. R. T. Co.'s 6 Year 5% Secured Gold Notes .....	40,000,000.00
New York Municipal Railway Corporation—5% Bonds .....	40,000,000.00
	<u>\$179,409,040.00</u>
Less in Treasury or pledged as collateral..... "C" .....	\$57,111,500.00
Deposited with Trustees of Mortgages .... "D" .....	1,863,000.00
	<u>58,974,500.00</u>
	<u>\$120,434,540.00</u>
<b>REAL ESTATE MORTGAGES.....</b>	<b>448,500.00</b>
<b>CURRENT LIABILITIES:</b>	
Bills Payable (secured by deposit of Brooklyn Rapid Transit Company Refunding Bonds) .....	2,750,000.00
Accounts Payable (including interest and rentals vouchered, and Dividend payable July 1, 1913).....	3,302,989.95
Taxes Accrued .....	1,636,882.18
Interest Accrued on Funded Debt.....	615,383.35
Interest and Rentals Accrued.....	32,879.29
	<u>8,338,134.77</u>
<b>RESERVES:</b>	
Insurance Reserve .....	472,118.70
Accrued Amortization of Capital and Sinking Fund Accrual .....	884,719.44
Special Reserve .....	957,966.66
	<u>2,314,804.80</u>
<b>SURPLUS .....</b>	<b>7,904,606.63</b>
	<u>\$189,277,813.16</u>

LEHIGH VALLEY RAILROAD COMPANY—FIFTY-NINTH ANNUAL REPORT.

PHILADELPHIA, August 6, 1913.

To the Stockholders of the LEHIGH VALLEY RAILROAD COMPANY.  
The Board of Directors herewith submit the annual report of the business and condition of your Company for the fiscal year ended June 30, 1913.

MILEAGE.

The first track mileage owned or controlled and operated by the Lehigh Valley Railroad Company, the main line of which is double track, extending from Jersey City, N. J., to Buffalo and Suspension Bridge, N. Y., is as follows:

	MILES
Lehigh Valley Railroad Company.....	317.16
Controlled by ownership of entire capital stock.....	934.87
Controlled by ownership of majority of capital stock and lease.....	115.37
Operated under lease .....	27.73
	<u>1,395.13</u>
Total mileage operated (owned or controlled).....	1,395.13
Trackage rights over railroads owned by other companies.....	43.77

Total first track mileage .....

1,438.90  
In addition to the above there are 596.05 miles, or 41.42 per cent., of second track, 92.34 miles of third track, 44.84 miles of fourth track and 1,182.70 miles of yard tracks and sidings, a total of 3,354.83 miles of track in operation at the close of the year. A detailed statement of track mileage is shown on pages 47 to 49. The average number of miles of railway operated for the year was 1,450.97, upon which the mileage statistics in certain tables submitted in this report are based.

Several changes have been made in the mileage heretofore shown under trackage rights on lines of other companies, the principal items being the elimination of first and second track mileage between West Newark Junction, N. J., and Jersey City, N. J., by reason of the cancellation of the agreement with the Pennsylvania Railroad Company for the running of passenger trains into their Jersey City terminal, the omission of certain mileage over the Niagara Falls Branch of the New York Central and Hudson River Railroad Company at North Tonawanda, N. Y., and the omission of mileage on lines of the Pennsylvania Railroad Company between Schuylkill Haven Junction, Pa., and Pottsville, Pa., and between New Boston Junction, Pa., and Pottsville, Pa., over which this Company has ceased running its trains. These deductions are partially offset by the acquisition of trackage rights over the lines of the Central Railroad Company of New Jersey between Oak Island Junction, N. J., and Jersey City, N. J., and in connection with other changes of minor importance, show a net decrease of 15.04 miles of total first track miles operated, and a decrease of 9.84 miles of second track. The increases of 19.07 miles of third track and 7.26 miles of fourth track are due to the extension of the third and fourth track system.

OPERATING REVENUES AND EXPENSES.

The following statement sets forth the gross revenues and expenses and net revenue from operation for the fiscal year, not including outside operations and other income, compared with similar figures for the fiscal year 1912. The complete income account appears on page 24.

GROSS OPERATING REVENUES.

	From	1913.	1912.	Increase.
Coal freight .....		\$20,385,389.09	\$16,301,316.24	\$4,084,072.85
Merchandise freight .....		16,339,748.97	14,591,239.56	1,748,509.41
Passenger .....		4,867,554.03	4,703,733.52	163,820.51
Mail .....		191,821.11	191,703.74	117.37
Express .....		506,191.11	471,957.22	34,233.89
Other transportation .....		415,731.87	379,919.42	35,812.29
Miscellaneous .....		336,935.87	266,065.51	70,870.36
Total operating revenues.....		\$43,043,371.89	\$36,905,935.21	\$6,137,436.68

OPERATING EXPENSES.

	1913.	1912.	Increase.
Maintenance of way and structures .....	\$5,694,422.24	\$3,963,589.12	\$1,730,833.12
Maintenance of equipment.....	7,561,270.87	6,313,316.76	1,247,954.11
Traffic expenses .....	982,857.66	980,116.82	2,740.84
Transportation expenses .....	13,993,617.35	12,606,961.58	1,386,655.77
General expenses .....	875,651.45	856,265.53	19,385.92
Total operating expenses.....	\$29,107,819.57	\$24,720,249.81	\$4,387,569.76
NET OPERATING REVENUE.....	\$13,935,552.32	\$12,185,685.40	\$1,749,866.92
Ratio of operating expenses to operating revenues .....	67.62%	66.98%	.64%

OPERATING REVENUES.

**Coal Freight.**  
The transportation of coal and coke produced a revenue of \$20,385,389.09, an increase of \$4,084,072.85, or 25.05 per cent., as compared with the preceding twelve months.  
The percentage of coal freight revenue to total operating revenues was 47.36 per cent., an increase of 3.19 per cent.  
The coal and coke transported, excluding the Company's supply coal, was 17,895,407 tons, an increase of 2,728,554 tons, or 17.99 per cent.  
This class of tonnage was 55.29 per cent. of the total tonnage hauled during the year, an increase of 1.15 per cent.

**Merchandise Freight.**  
The revenue received from the transportation of merchandise freight was \$16,339,748.97, an increase of \$1,748,509.41, or 11.98 per cent., as compared with the preceding year.  
The percentage of revenue derived from the transportation of merchandise freight was 37.96 per cent. of the total operating revenues, a decrease of 1.58 per cent.  
The tonnage moved, excluding Company's material, was 14,472,389 tons, an increase of 12.66 per cent.

**General Freight.**  
The total revenue from both coal and merchandise freight was \$36,725,138.06, an increase of \$5,832,582.26, or 18.88 per cent., as compared with the preceding twelve months.

The entire freight traffic amounted to 32,367,796 tons, an increase of 4,354,496 tons, or 15.54 per cent.

The number of tons carried one mile was 5,812,384,917, an increase of 1,027,307,531 ton miles, or 21.47 per cent.

The average haul was 179.57 miles, an increase of 8.76 miles, or 5.13 per cent.

The average revenue per ton was 113.46 cents, as compared with 110.28 cents last year, an increase of 3.18 cents, or 2.88 per cent.

Company's freight, not included in the above, amounted to 3,322,041 tons, an increase of 377,662 tons, or 12.83 per cent.

The total freight train mileage was 9,703,311 miles, an increase of 1,250,333 miles, or 14.79 per cent.

The revenue received per freight train mile was \$3.78, an increase of \$0.13, or 3.56 per cent.

The average trainload of revenue freight was 599.01 tons, an increase of 32.93 tons, or 5.82 per cent. Including Company's freight, the average trainload was 620.71 tons, an increase of 33.20 tons, or 5.65 per cent.

**Passenger.**  
The earnings from passenger traffic amounted to \$4,867,554.03, an increase of \$163,820.51, or 3.48 per cent., over the preceding year.

The total number of passengers carried was 5,518,524, an increase of 168,676, or 3.15 per cent.

The number of passengers carried one mile increased 6,695,049, or 2.53 per cent.

The average revenue per passenger was 88.20 cents, an increase of .28 cent, or .32 per cent.

The average revenue per passenger per mile was 1.792 cents, an increase of .017 cent, or .96 per cent.

The average distance traveled by each passenger was 49.23 miles, a decrease of .30 mile, or .61 per cent.

Passenger train mileage was 4,491,013, a decrease of 32,407 miles, or .72 per cent., as compared with an increase in this revenue of 3.48 per cent.

The average revenue from passengers per passenger train mile was 108.38 cents, an increase of 4.39 cents, or 4.22 per cent.

**Mail.**  
For the transportation of United States mails the Federal Government paid the sum of \$191,821.11, an increase of \$117.37.

**Express.**  
The revenue from this class of business amounted to \$506,191.11, an increase of \$34,233.89.

**Other Transportation.**  
The earnings derived from transportation other than shown under the preceding headings were \$415,731.71, an increase of \$35,812.29.

**Miscellaneous.**  
Miscellaneous revenue amounted to \$336,935.87, an increase of \$70,870.36.

#### OPERATING EXPENSES.

**Maintenance of Way.**  
The expenditures for the maintenance of way and structures amounted to \$5,694,422.24, an increase of \$1,730,833.12, or 43.67 per cent., as compared with the preceding year.

Seven steel bridges and one concrete-steel bridge were built in connection with additional track construction. Sixteen steel bridges and nine concrete-steel bridges were placed in the track, replacing light steel or wooden bridges, and twelve steel bridges were strengthened. Nineteen bridges were replaced by culverts and five small bridges were abandoned and the openings filled. Two new steel highway bridges with solid floors and one steel foot bridge were erected. Two wooden highway bridges were replaced by steel structures and one steel highway bridge was renewed. One wooden highway bridge was replaced by a culvert.

13,560 tons of 110-pound rail, 50,823 tons of 100-pound rail and 602 tons of 90-pound rail, together with necessary frogs, switches, etc., were placed in the track.

1,425,328 tie plates and 688,109 anti-rail creepers were used. 948,864 cross ties, 2,500,803 feet B. M. switch ties, 836,968 feet B. M. bridge ties and lumber amounting to 5,578,645 feet B. M. were used.

569,441 of the cross ties, 1,790,798 feet B. M. of switch ties and 778,038 feet B. M. of bridge ties were treated with creosote.

90,274 cubic yards of crushed stone were used in ballasting track. 46,004 feet of drain tile were placed in the roadbed.

6.33 miles of new telegraph and telephone pole line were erected. 52.72 miles rebuilt and 33.75 miles reset. 1,164.40 miles of copper and 99.85 miles of iron wire were used in extending and renewing the telephone, telegraph and signal wires on the system.

**Maintenance of Equipment.**  
The sum of \$7,561,270.87 was expended for the maintenance of equipment, an increase of \$1,247,954.11, or 19.77 per cent., over the preceding twelve months. Included therein is a charge of \$1,144,007.97 for the depreciation of equipment, as called for in the accounting system prescribed by the Interstate Commerce Commission.

Forty-seven passenger coaches and five combined passenger and baggage cars were converted into workmen's cars, three postal and eleven combined baggage and mail cars into express cars, one dining car into a business car, and one hundred and ten produce cars into ice cars. Eleven passenger coaches, two combined passenger and baggage cars and thirteen box cars were transferred to caboose service and forty-five freight equipment cars to road service.

Sixty-seven worn-out locomotives, nine passenger coaches, four combined passenger and baggage cars, four combined baggage and mail cars, one fruit car, 901 freight equipment cars and 161 road service cars were condemned and either sold or destroyed during the year and their value written off the books by appropriate charges through operating expenses.

Eight hundred locomotives received heavy and general repairs. 481 passenger equipment cars received heavy repairs, 382 were painted and varnished, and 51 equipped with electric lighting apparatus. Steel underframes were applied to 2,962 wooden freight cars, making a total of 10,593 cars so equipped during the last five years. 22,476 freight equipment cars received heavy and general repairs.

The total number of locomotives on hand at the close of the year was 903, with a tractive power of 27,655,900 pounds. The total number of freight equipment cars was 43,818, with a capacity of 1,585,192.5 tons.

**Traffic Expenses.**  
The expenditures under this heading amounted to \$982,857.66, an increase of \$2,740.84 as compared with the preceding twelve months.

**Transportation Expenses.**  
The cost of conducting transportation was \$13,993,617.35, an increase of \$1,386,655.77, or 11.00 per cent., over the preceding year.

The ratio of transportation expenses to total operating revenues was 32.51 per cent., as compared with 34.16 per cent. last year, a decrease of 1.65 per cent.

#### General Expenses.

This class of expenses amounted to \$875,651.45, or 2.03 per cent. of the total operating revenues.

#### Taxes.

The taxes accrued on your property, capital and business during the year amounted to \$1,609,151.39, an increase of \$157,840.22 over the preceding year.

#### ADDITIONS AND BETTERMENTS.

During the year there was expended for the acquisition of new property and for the improvement and development of existing property the sum of \$6,507,721.40, which was charged to Additions and Betterments. A classification of these expenditures, as required by the Interstate Commerce Commission, appears on page 44. The more important expenditures are here specifically referred to:—

New equipment has been purchased and added to the property during the year as follows: Fifty-one freight locomotives, one passenger locomotive, fifteen switching locomotives, six locomotive tenders, three steel library buffet cars, one thousand steel underframe refrigerator cars, one caboose car, four locomotive cranes, eighty-eight steel underframe pneumatic dump cars, one scale test car and one derrick car.

Orders have also been placed for thirty-eight freight locomotives, five passenger locomotives, fifteen switching locomotives, seven locomotive tenders, one thousand steel underframe box cars and one thousand steel coal cars.

The third track was extended from Three Bridges to Stanton, a distance of 5.52 miles, from Stafford to North LeRoy, a distance of 4.87 miles, and a further extension from North LeRoy to Pittsburg and Lehigh Junction, a distance of 4.98 miles, is under construction. Third and fourth tracks were extended from South Somerville to Flagtown, a distance of 4.98 miles, and from Parkview to West Elizabeth, a distance of 1.03 miles. These extensions will greatly facilitate the movement of freight and avoid yard congestion.

95,779 feet, or 18.14 miles, of Company's sidings and 36,010 feet, or 6.82 miles, of industrial sidings were constructed during the year.

A westbound passing siding, 1.32 miles in length, was constructed at Scottsville.

Eight tracks, with a capacity of 248 cars, were added to the yard at Richards. Additional sidings of thirty-six and thirty-four cars capacity were laid at Catasaquaque and Suspension Bridge, respectively. Tracks in Coxton Yard were remodelled and extended, increasing the capacity by twenty-nine cars. Additional tracks of two hundred cars capacity at Florence, referred to in the preceding report, were completed. Work is now under way at that point to provide room for the construction of a switching lead from the Florence Yard.

Additional freight delivery tracks with paved driveways were constructed at Irvington and at New Brunswick Avenue, Perth Amboy, and the driveways leading to the coal trestle at Bound Brook and the driveways at the team tracks at Pittston were paved. In order to conform to the grade established by the city of Jersey City, it was necessary to raise and repave the driveways and also raise the sidewalk and tracks at the Grand Street freight station, Jersey City.

A "Y" was constructed at Tannery to permit of turning the large Mikado engines and the curvature of the "Y" at Fairview is being reduced for the same purpose.

A change was made in the location of the connection from the main tracks to the coal shipping trestle and yard tracks at Canastota in order to eliminate the crossing at grade of six tracks of the New York Central and Hudson River Railroad.

Notice having been served by the Pennsylvania Railroad Company, effective May 1, 1913, terminating the contract giving this Company the right of trackage from Newark east, including the use of its passenger terminal facilities at Jersey City and Cortlandt and Desbrosses Streets, New York, arrangements were made with the Central Railroad Company of New Jersey for trackage east of Oak Island Junction and the use of its passenger terminals at Jersey City and New York. In connection with this change a brick passenger station was constructed at Newark, the tracks between Parkview and Oak Island Junction were rebuilt and ballasted with stone and a passenger terminal yard, including a steam heating system, air compressor plant and other necessary facilities, was constructed at Johnson Avenue, Jersey City.

An extension of the Seneca Falls Branch for a distance of 5.7 miles eastward to a connection with the New York Central and Hudson River Railroad was begun during the year and an agreement entered into with that company granting your Company trackage rights to Cayuga, a distance of 2.2 miles, where a connection is made with your line.

Substantial progress has been made in the development of the new passenger and freight terminals at Buffalo, located on Main and Washington Streets respectively. The work of clearing the site is under way and the proposed changes in viaducts and streets affected by this work have been approved by the city authorities. Plans for the station buildings are now under consideration with the Terminal Commission of Buffalo.

The reinforced concrete grain storage elevator at the National Docks Terminal, New York Harbor, referred to in the last annual report, is practically completed and will be in operation at an early date.

The coal unloading plant for the transshipment of coal from cars to vessels at Perth Amboy, mentioned in last year's report, is now in operation.

Heavy repairs were made to the coal shipping trestles at Tift Farm and North Fair Haven, and at the latter point a number of pockets were raised to permit the loading of larger boats. The ore dock at Tift Farm has been rebuilt for a distance of six hundred feet. Two additional large capacity steam cranes are being installed at that point for the handling of rails, ore and pig iron, which will enable more prompt despatch of vessels.

An ice-house of 10,000 tons capacity, with modern machinery for handling and crushing ice, was built at Sayre, and smaller ice-houses were constructed at Perth Amboy, Easton and Lehigh. The ice-houses at Clinton and West Portal and freight office and platform at Geneva freight station were enlarged.

A concrete and steel transfer platform of two hundred cars capacity is in course of construction at Manchester. By concentrating the work at that point the transfer platform at Dingen Street, Buffalo, where operations are conducted at a disadvantage, will be abandoned and the work at Sayre and other points will be reduced.

To replace a shed destroyed by fire several years ago, a single story freight shed of steel and corrugated iron construction was built on Pier "B," Jersey City.

Pier "C," Jersey City, was equipped with an automatic fire alarm system, and Pier 66, New York, with an automatic sprinkler system.

In order to expedite the handling of freight, fifty electrically operated freight trucks have been placed in service at the Lake Freight House, Buffalo. A steel and concrete garage was built and necessary charging apparatus installed.

Fifty-five gasoline motor cars were purchased for the use of section, bridge, signal and telegraph gangs, making a total of eighty-one of these motors now in service.

Two electric derricks of two tons capacity each were installed at the team tracks at Rochester and a twenty-ton transfer crane was erected at Cortland.

A coal conveyor was installed at the boiler house at Easton shops and pneumatic ash conveyors, for the handling of locomotive ashes direct to cars, were constructed at Mount Carmel, Weatherly and Wilkes-Barre.

A water station was installed at Flax Mill, together with a concrete lined reservoir having a capacity of 225,000 gallons and supplying two 12-inch water columns. A new gravity water supply has been completed at Hays Creek, concrete lined reservoirs of 40,000 gallons and 275,000 gallons capacity having been constructed and two 12-inch water columns erected. To replace worn-out wooden tanks, steel standpipes of 70,000 and 212,000 gallons capacity were erected at Lodi and East Buffalo, respectively. A 100,000-gallon steel tank was installed at Johnson Avenue, Jersey City. New 12-inch water columns were erected at Trenton, Manville and Hazleton.

A mechanical interlocking plant of twenty-eight levers was constructed at Tannery to operate the switches and signals governing the connection between the main line and the Hays Creek Branch. A similar plant of nineteen levers was installed at the west end of Oak Island Yard, controlling the connection of the yard tracks with the main line passenger tracks at that point. New mechanical interlocking plants were installed at Three Bridges, Richards and Treichlers, consisting of twenty, sixteen and twenty-four levers, respectively, to operate the switches and signals at the ends of the third and fourth track systems.

The disc automatic signals between South Somerville and Phillipsburg have been replaced with three-position upper-quadrant automatic signals. Three-position automatic signals were installed between Ackerman and Tannery on the Hays Creek Branch. Thirteen audible and visible crossing signals and one audible crossing signal were installed at highway crossings.

The entire main line of your road is now equipped with telephone train dispatching lines, the circuit between Manchester and Buffalo, referred to in last year's report, having been completed during the year. In addition, the branch line extending from Elmira to Camden was similarly equipped. One hundred and thirty-nine portable telephone sets were installed on passenger and freight trains.

Telegraph and telephone lines were rebuilt for a distance of 8.3 miles on the Mabanoy and Hazleton Division, 6.4 miles on the Wyoming Division, 20.8 miles on the Auburn Division and 16.37 miles on the Buffalo Division. Poles were re-set for a distance of twenty-one miles on the Wyoming Division and eleven miles on the Auburn Division.

FINANCIAL.

No additional capital obligations have been issued and sold by your Company during the year, the resources having been sufficient for all expenditures. In fact, the capital obligations have been reduced by the sum of \$2,015,000, as follows:

DESCRIPTION.	INTEREST RATE.	MATURITY.	AMOUNT.
Collateral Trust Bonds .....	4%	Feb. and Aug. . . .	\$1,000,000
Equipment Trust, Series I, Certificates .....	4%	September .....	400,000
Equipment Trust, Series J, Certificates .....	4½%	March and Sept. . . .	500,000
Mortgages on Real Estate.....	5.4%	December .....	115,000
<b>Total .....</b>			<b>\$2,015,000</b>

The retirement of these obligations, all of which were outstanding excepting Equipment Trust, Series I, Certificates held in the treasury, reduces the fixed charges of the Company \$68,710 per annum.

An additional Equipment Trust, known as Series K, authorizing the issuance of \$1,500,000 Four Per Cent. Certificates, was created and is a lien upon one thousand steel underframe refrigerator cars, thirty steel passenger coaches and twenty steel smoking coaches. These certificates mature in semi-annual installments March 1st and September 1st each year, the last installment falling due September 1, 1917. \$150,000 matured March 1, 1913, and were retired. The remainder, \$1,350,000, have been placed in the treasury and are available for sale or other use as the necessity may arise.

The subsidiary companies owned by the Lehigh Valley Railroad Company, to which it made cash advances for expenditures to cover additions and betterments made during the past year to their respective properties, have reimbursed your Company by the issuance of Fifty-Year Five Per Cent. Gold Debentures, as follows:

Lehigh Valley Railroad Company of New Jersey.....	\$809,000
The Lehigh Valley Rail Way Company.....	717,000
National Storage Company .....	580,000
Pennsylvania and New York Canal and Railroad Company .....	253,000
Lehigh Valley Transportation Company.....	66,000
Loyalsock Railroad Company.....	3,000

These securities have been deposited with the Trustee of the General Consolidated Mortgage as required thereby.

Your Company has also received and placed in its treasury \$157,000 Wyoming Valley Water Supply Company First Mortgage Five Per Cent. Bonds in reimbursement of advances made to that Company for capital expenditures.

Additional advances were made to subsidiary real estate companies in the sum of \$151,499.44 to cover the purchase of land for the improvement and extension of terminal and other facilities.

It has been the policy of your Company, as opportunity afforded, to reduce the number of its subsidiary companies. During the year the Jersey City Belt Line Railway Company and the Newark Bay Railway Company were dissolved. Those companies were organized in 1890 for the purpose of constructing certain branches in the vicinity of the Jersey City Terminal. These branches have now been projected by the Lehigh Valley Railroad Company of New Jersey, which obviated the necessity of maintaining the two former corporations.

The book value of the capital stock of Coxie Brothers & Company, Incorporated, was reduced by the sum of \$1,000,000. Profit and Loss Account having been charged with \$980,362.28, the balance being charged to a small depreciation reserve, which was thereby extinguished. It has been the practice in each of the five preceding years to reduce the value of this property by a similar amount which fully offsets any depreciation.

Working Assets are \$32,277,506.91 in excess of Working Liabilities. Semi-annual dividends of five per cent. each were declared in December, 1912, and June, 1913, on the preferred and common capital stocks of the Company, payable respectively in January and July, 1913.

For comparative purposes, it has been necessary to re-state the Income Account, for the year 1912, appearing on page 24, owing to the fact that the Interstate Commerce Commission issued an order, effective July 1, 1912, requiring certain changes in the items "Taxes Accrued," "Other Income" and "Deductions from Income."

It will be observed that in the statement "Rentals of Leased Roads and Guaranties," appearing on page 29, the guaranteed dividends on the preferred and consolidated stocks of the Morris Canal and Banking Company are not shown for the year. This for the reason that, under the accounting

classification of the Interstate Commerce Commission, the same are included in the Income Account in the item "Miscellaneous Deductions." The rental which this Company has been paying for the use of certain tracks owned by the State Line and Sullivan Railroad Company and the Raritan Terminal and Transportation Company is this year included in the statement "Rentals of Leased Roads and Guaranties" in order to bring the same into harmony with the rules of the Interstate Commerce Commission.

The accounts of the Company for the year, including the cash and security balances, have been examined and verified by certified public accountants, their certificate as to the correctness of the same appearing on page 19.

GENERAL REMARKS.

It is gratifying to observe that the operating revenues of the Company show a healthy growth as compared with previous years. It should be borne in mind, however, that the considerable increase in earnings over those of the preceding year does not reflect a normal increase, since in that year the revenues were greatly reduced by reason of the suspension of mining in the anthracite coal fields for the months of April and May pending negotiations for a new wage agreement between the mining companies and their employes.

The increase in operating expenses is due to the higher rates of wages paid to labor in all branches of the Company's service, to the prevailing high price of materials and supplies, to liberal appropriations for the maintenance of roadway and equipment and as well to the added expense of handling an increased volume of traffic.

The attention of the Company's stockholders is particularly called to the tax accruals, which are every year showing a steady increase and now amount to 3.74 per cent. of the Company's gross operating revenues. In the last five years taxes have increased 43.31 per cent. whereas the gross operating revenues have increased but 21.21 per cent. A further serious burden, which is reflected in the cost of transportation, is the wages of the additional men that are now arbitrarily required on trains as a result of the legislative enactment of the so-called "Full Crew Bills," which have been passed in the States of New York, New Jersey and Pennsylvania.

The floating equipment of the Lehigh Valley Transportation Company, the capital stock of which is owned by your Company, has been fully maintained. One steel tug and two steam hoisting barges were purchased and received during the year. In addition to the foregoing, contracts have been made for two steam hoisting barges and ten covered barges, five of which will be equipped for heating and refrigerating. Thirteen wooden coal barges were converted into grain boats. One tug and eight barges, unfit for further service, were condemned and sold or otherwise disposed of. The floating equipment used by your Company and its affiliated companies is set forth in detail on page 46.

Notwithstanding the efforts of your Company, no relief has as yet been obtained from the Legislature of the State of New Jersey in respect to the operation of the Morris Canal. During the past session of that Legislature a bill was introduced which would have been acceptable to this Company if passed and which reconciled virtually all the interests concerned with the matter of abandoning the Canal. Unfortunately the Legislature adjourned without taking any action on the bill in question. However, the Morris Canal Abandonment Commission, appointed under a resolution passed by the Legislature at the preceding session, is expected to make a report next fall and there is a prospect of some satisfactory settlement of the matter being made within the next year.

The operation of the Lehigh and New York Railroad under the lease made in 1895 has resulted in a loss of \$130,710.41 for the year just closed. A suit, brought by certain of the preferred stockholders of that Company against the Lehigh Valley Railroad Company in respect of that operation and the method of accounting for the results thereof, is now pending.

There were located on the system during the year seventy-three new industries, of which sixty-three have direct track connections with the Company's lines.

The total payments direct to labor for the year amounted to \$17,639,627.77, or 54.88 per cent. of the total operating expenses, including outside operations, the same having been distributed among an average of 22,800 employes.

The sum of \$56,991.34 was contributed by the Company to its Employees' Relief Fund.

Mr. Fred M. Kirby, of Wilkes-Barre, Pennsylvania, was elected a director to fill the vacancy caused by the resignation of Mr. Alfred C. Harrison.

On behalf of the Board of Directors, the officers and employes are thanked for the efficient and faithful services rendered by them during the year.

E. B. THOMAS,  
President.

COMPARATIVE INCOME ACCOUNT FOR THE YEARS ENDED  
JUNE 30, 1913, AND 1912.

	1913.	1912.	INCREASE OR DECREASE.
<b>OPERATING REVENUES:—</b>			
Coal freight revenue.....	\$20,385,389.09	\$16,301,316.24	\$4,084,072.85
Merchandise freight revenue.....	16,339,748.97	14,591,239.56	1,748,509.41
Passenger revenue .....	4,867,554.03	4,703,733.32	163,820.51
Mail revenue .....	191,821.11	191,703.74	117.37
Express revenue .....	506,191.11	471,957.22	34,233.89
Other transportation revenue .....	415,731.71	379,919.42	35,812.29
Miscellaneous revenue .....	336,935.87	266,065.51	70,870.36
<b>Total operating revenues.....</b>	<b>\$43,043,371.89</b>	<b>\$36,905,935.21</b>	<b>\$6,137,436.68</b>
<b>OPERATING EXPENSES:—</b>			
Maintenance of way and structures .....	\$5,694,422.24	\$3,963,589.12	\$1,730,833.12
Maintenance of equipment.....	7,561,270.87	6,313,316.76	1,247,954.11
Traffic expenses .....	982,857.66	980,116.82	2,740.84
Transportation expenses .....	13,993,617.35	12,606,961.58	1,386,655.77
General expenses .....	875,651.45	856,265.53	19,385.92
<b>Total operating expenses.....</b>	<b>\$29,107,819.57</b>	<b>\$24,720,249.81</b>	<b>\$4,387,569.76</b>
Ratio of operating expenses to operating revenues .....			
Net operating revenue.....	67.62%	66.98%	.64%
OUTSIDE OPERATIONS, NET.....	\$13,935,552.32	\$12,185,685.40	\$1,749,866.92
	*280,210.32	*291,239.44	11,029.12
<b>TOTAL NET REVENUE.....</b>	<b>\$13,655,342.00</b>	<b>\$11,894,445.96</b>	<b>\$1,760,896.04</b>
<b>RAILWAY TAX ACCRUALS.....</b>	<b>1,447,205.04</b>	<b>1,312,011.62</b>	<b>135,193.42</b>
<b>OPERATING INCOME .....</b>	<b>\$12,208,136.96</b>	<b>\$10,582,434.34</b>	<b>\$1,625,702.62</b>
<b>OTHER INCOME:—</b>			
Hire of equipment—Balance.....	\$286,732.93	\$72,257.51	\$214,475.42
Joint facility rent income.....	416,543.34	316,599.20	99,944.14
Dividend income .....	666,123.10	659,495.25	6,627.85

	1913.	1912.	INCREASE OR DECREASE
Income from funded securities	382,314.16	461,579.45	—79,265.29
Miscellaneous income	552,041.07	611,529.97	—59,488.90
Total other income	\$2,303,754.60	\$2,116,461.38	\$187,293.22
<b>TOTAL INCOME</b>	<b>\$14,511,891.56</b>	<b>\$12,698,895.72</b>	<b>\$1,812,995.84</b>
<b>DEDUCTIONS FROM INCOME:—</b>			
Interest deductions for funded debt	\$3,127,360.15	\$3,167,635.15	—\$40,275.00
Deductions for lease of other roads	2,239,295.00	2,239,295.00	.....
Joint facility rent deductions	167,062.33	153,926.71	13,135.62
Miscellaneous tax accruals	161,946.35	139,299.55	22,646.80
Miscellaneous deductions	54,399.51	185,719.22	—131,319.71
Total deductions from income	\$5,750,063.34	\$5,885,875.63	—\$135,812.29
<b>NET INCOME</b>	<b>\$8,761,828.22</b>	<b>\$6,813,020.09</b>	<b>\$1,948,808.13</b>

\*Deficit.

**PROFIT AND LOSS ACCOUNT FOR THE YEAR ENDED JUNE 30, 1913.**

	Dr.	Cr.
Balance, July 1, 1912		\$23,444,703.46
Net income for year ended June 30, 1913		8,761,828.22
Reduction of book value of capital stock of Coxe Bros. & Co., Inc.	\$980,362.28	
Property abandoned	87,562.28	
Miscellaneous adjustments	11,575.70	
Dividends:		
Five per cent. on preferred stock, paid Jan. 11, 1913	\$5,315.00	
Five per cent. on common stock, paid Jan. 11, 1913	3,025,085.00	
Five per cent. on preferred stock, due July 12, 1913	5,315.00	
Five per cent. on common stock, due July 12, 1913	3,025,085.00	
	6,060,800.00	
Balance, June 30, 1913	25,066,231.42	
	\$32,206,531.68	\$32,206,531.68

Balance brought forward, July 1, 1913. \$25,066,231.42

**GENERAL BALANCE SHEET, JUNE 30, 1913.**

Dr.	Cr.
<b>ASSETS.</b>	
<b>ROAD AND EQUIPMENT:—</b>	
Investment to June 30, 1907	\$54,365,714.13
Investment since June 30, 1907	18,494,236.23
	\$72,859,950.36
Less reserve for accrued depreciation	6,010,546.64
	\$66,849,403.72
<b>SECURITIES:—</b>	
Securities of proprietary, affiliated, and controlled companies—pledged	\$32,289,451.58
Securities of proprietary, affiliated, and controlled companies—unpledged	3,981,432.83
	36,270,884.41
<b>OTHER INVESTMENTS:—</b>	
Advances to proprietary, affiliated, and controlled companies for construction, equipment and betterments	\$115,797.25
Real estate	479,785.99
Advances to subsidiary real estate companies	3,208,360.66
Securities—pledged	27,701,855.93
Securities—unpledged	8,378,797.42
	39,884,597.25
<b>WORKING ASSETS:—</b>	
Cash	\$13,149,152.16
Securities issued or assumed—held in treasury	17,211,000.00
Marketable securities	325,000.00
Traffic and car-service balances due from other companies	163,023.21
Net balance due from agents and conductors	1,124,512.38
Miscellaneous accounts receivable	1,629,152.35
Materials and supplies	3,865,345.77
Other working assets	158,997.81
	37,626,183.68
<b>ACCRUED INCOME NOT DUE:—</b>	
Unmatured interest, dividends and rents receivable	231,719.19
<b>DEFERRED DEBIT ITEMS:—</b>	
Advances	\$916,510.70
Rents and insurance paid in advance	158,099.71
Other deferred debit items	782,012.85
	1,856,623.26
<b>TOTAL ASSETS</b>	<b>\$182,719,411.51</b>

**LIABILITIES.**

<b>CAPITAL STOCK:—</b>	
1,210,034 shares common stock, par \$50	\$60,501,700.00
2,126 shares preferred stock, par \$50	106,300.00
	\$60,608,000.00
<b>FUNDED DEBT:—</b>	
Mortgage bonds	\$67,639,000.00
Collateral trust bonds	13,000,000.00
Equipment trust obligations	5,200,000.00
Mortgages on real estate	1,669.18
	85,840,669.18
<b>WORKING LIABILITIES:—</b>	
Traffic and car-service balances due to other companies	\$71,027.06
Audited vouchers and wages unpaid	3,715,180.04
Miscellaneous accounts payable	188,718.29
Matured interest, dividends and rents unpaid	396,325.50
Other working liabilities	977,425.88
	5,348,676.77

	Cr.
<b>ACCRUED LIABILITIES NOT DUE:—</b>	
Unmatured interest and rents payable	\$908,956.31
Dividends declared June 18, due July 12, 1913	3,030,400.00
Taxes accrued	597,735.36
	4,537,091.67
<b>DEFERRED CREDIT ITEMS:—</b>	
Other deferred credit items	1,318,742.47
<b>PROFIT AND LOSS</b>	<b>25,066,231.42</b>
<b>TOTAL LIABILITIES</b>	<b>\$182,719,411.51</b>

**LEHIGH VALLEY COAL COMPANY.**

**REPORT OF OPERATIONS.**

PHILADELPHIA, August 5, 1913.

The annual report of the operations conducted by The Lehigh Valley Coal Company for the fiscal year ended June 30, 1913, and statements indicating its financial condition at the close of the year, are herewith submitted.

The total net income of the Company from all sources, after deducting charges for royalties, sinking funds, depreciation of the property and interest on the funded debt, amounted to \$1,471,274.87, an increase of \$309,033.55 as compared with the preceding year. This does not represent a normal increase, however, owing to the fact that the revenues of the previous fiscal year were reduced by reason of the suspension of mining during the months of April and May, 1912, pending negotiations for a new agreement between the anthracite mining companies and their employes.

The production of anthracite coal from the lands owned and leased by The Lehigh Valley Coal Company, including that mined by tenants, was 8,860,032 gross tons.

The percentage of sizes above pea produced by the mining operations of the Company was 68.68 per cent., an increase of 1.01 per cent.

The number of breaker hours worked was 47,014.

From the Snow Shoe lands 350,105 gross tons of bituminous coal were mined, an increase of 70,021 tons.

The property of the Company has been fully maintained throughout the year. The sum of \$312,211 was expended for additions and betterments.

A new breaker is in course of construction at Franklin Colliery to replace the old breaker at that point, which is worn out. It will be constructed of fireproof material and will have a considerably greater capacity than the old breaker. The same will be placed in operation at an early date.

The work of modernizing the breaker, boiler plant and other important machinery at Park Colliery has been carried on throughout the year and in such a manner as to interfere but little with the regular operation of that colliery.

The pumping plants at Exeter Colliery have been concentrated and enlarged, it having become necessary to increase the pumping capacity to overcome the greater amount of water encountered in the extensive mining operations conducted at that point.

At Sayre Colliery the pumping plants have also been concentrated and improved.

An electric haulage plant has been installed at Packer No. 4 Colliery. The erection of a new washery to re-work the culm banks on the west end of the Delano lands is under way and will be completed during the coming year.

Complying with the decision rendered by the Supreme Court of the United States in the suit of the Federal Government against this and other anthracite mining companies, your Company is no longer purchasing coal from other producers under 65% contracts or any similar arrangement, and has no interest in any mining operations other than those conducted by it on its own lands or by tenants who lease lands from the Company.

In the past this Company has not had a comprehensive method of depreciating its property. The system prevailing was to meet depreciation by charging Income Account with varying amounts for improvements to the property and not adding them to the balance sheet as a capital asset. Thus not only was the value of the improvement liable to be lost sight of, but the depreciation was not measured by the actual mining of coal. Accordingly, after careful consideration and acting with the advice of expert accountants, beginning with the present fiscal year, a charge is being made to Income Account to measure the depreciation of the property on the basis of the amount of coal mined from the Company's lands, which depreciation is credited to a Reserve Account established for that purpose. Such additions and betterments as are made to the property are being charged to Capital Account and thus are properly set forth on the balance sheet. The accounts since January 1, 1909, have been revised on this basis as more fully appears in the Profit and Loss Statement.

No new capital obligations were issued by the Company during the year. The account appearing on the balance sheet as "Deferred Real Estate Payments," representing short term notes given for the acquisition of property in previous years, has been reduced by the sum of \$292,500. The total amount of such obligations now outstanding is \$800,000.

Payments amounting to \$109,379 were made to the sinking funds as required under the several mortgages on the Company's property.

The increase in Property and Plant represents, in the main, additions and betterments to the property, as heretofore mentioned.

An appropriation of \$50,000 has been made from the Profit and Loss Account and paid to the Company's Insurance Fund, making a total of \$110,547 in the latter account at the close of the year.

Current Assets are \$2,408,035 in excess of Current Liabilities.

Certified public accountants have verified the books and accounts of the Company and have furnished a certificate as to the correctness thereof, a copy of said certificate being appended.

F. M. CHASE,  
Vice-President and General Manager.

**PROFIT AND LOSS ACCOUNT FOR THE YEAR ENDED JUNE 30, 1913.**

	Dr.	Cr.
Credit balance, July 1, 1912		\$3,486,636.86
Net income for year ended June 30, 1913		1,471,274.87
Improvements, January 1, 1909, to June 30, 1912, originally deducted from Income		1,407,916.93
Depreciation of Improvements, January 1, 1909, to June 30, 1912, inclusive	\$2,566,240.25	
Appropriation for Insurance Fund	50,000.00	
Miscellaneous adjustments	35,349.40	
Balance, June 30, 1913	3,714,239.01	
	\$6,365,828.66	\$6,365,828.66
Credit balance brought forward, July 1, 1913		\$3,714,239.01

# Railway Age Gazette

PUBLISHED EVERY FRIDAY AND DAILY EIGHT TIMES IN JUNE, BY THE  
SIMMONS-BOARDMAN PUBLISHING COMPANY,  
WOOLWORTH BUILDING, NEW YORK.

CHICAGO: Transportation Bldg. CLEVELAND: Citizens' Bldg.  
LONDON: Queen Anne's Chambers, Westminster.

E. A. SIMMONS, *President.*

L. B. SHERMAN, *Vice-President.* HENRY LEE, *Sec'y & Treas.*  
The address of the company is the address of the officers.

### EDITORS.

SAMUEL O. DUNN, *Editor.*

ROY V. WRIGHT, <i>Managing Editor.</i>	H. H. SIMMONS	E. S. FAUST
W. E. HOOPER	H. F. LANE	F. W. KRAEGER
B. B. ADAMS	E. A. AVERILL	A. D. CLOUD
E. T. HOWSON	R. E. TRAYER	GEORGE L. FOWLER
	A. C. LOUDON	

Subscriptions, including 52 regular weekly issues and special daily editions published from time to time in New York, or in places other than New York, payable in advance and postage free:

United States and Mexico.....	\$5.00
Canada .....	6.00
Foreign Countries (excepting daily editions).....	8.00
Single Copies .....	15 cents each

Engineering and Maintenance of Way Edition and four Maintenance of Way Convention Daily issues, North America, \$1.00; foreign, \$2.00.

Entered at the Post Office at New York, N. Y., as mail matter of the second class.

WE GUARANTEE, that of this issue 8,150 copies were printed; that of those 8,150 copies, 6,875 were mailed to regular paid subscribers and 845 were provided for counter and news companies' sales; that the total copies printed this year to date were 336,809—an average of 8,863 copies a week.

VOLUME 55. SEPTEMBER 26, 1913. NUMBER 13.

## CONTENTS

### EDITORIAL:

Editorial Notes .....	549
Weak Spots in Discipline .....	550
*Illinois Central .....	551, 588
*Chicago & North Western.....	552, 590
Chicago, St. Paul, Minneapolis & Omaha.....	554, 594
New Books .....	554

### MISCELLANEOUS:

Increasing Freight Car Performance; by C. C. Riley.....	555
Specifications and Rules for Douglas Fir Car Material.....	557
*Adopted Design of the Quebec Bridge; by Ralph Modjeski.....	559
*Fuel Economy by the Engine Crew; by M. E. Wells.....	563
*New Western Pacific Shops at Sacramento, Cal.....	564
American Railway Safety Association.....	564
New Haven Officers' Salutatory.....	565
Congress of Refrigeration.....	567
*Large Passenger Locomotives for the C. & O.....	571
*Export of British and American Railway Equipment.....	572
*Drop Test of Heat Treated Chrome Vanadium Wheels.....	573
Foreign Railway Notes.....	558, 566, 573

### GENERAL NEWS SECTION..... 575

\*Illustrated.

DR. ARTHUR T. HADLEY has been elected a director of the New York, New Haven & Hartford. For years President Hadley has been the profoundest student of railway economics in this country not actively engaged in the management of any railroad property. In 1883, Dr. Hadley was an instructor in Yale University, with no prescribed duties, he began a course of lectures to such students as cared to hear him on some questions involving the economics of transportation. At that time there was then very little literature in English on these subjects. Charles Francis Adams, in the epoch-making early reports of the Massachusetts Railroad Commission, had shown that these questions were complicated and could only be solved by the observation and analysis of facts and the application of economic principles by minds capable of sound reasoning; and the *Railroad Gazette* under S. W. Dunning was endeavoring to find and show

the way to an understanding of the pending questions. The young Yale instructor therefore was asked to present in these columns the conclusions of a mind trained in economic reasoning on questions then agitating the nation. Dr. Hadley was then just beginning his great career, but as the son of the great Greek and English scholar, James Hadley, he found attentive hearers and readers. The series of articles by him, published in the *Railroad Gazette* in the early eighties were afterwards gathered together and, with some additions, published by G. P. Putnam's Sons under the name of "Railroad Transportation, its History and its Laws," which was one of the first of the small library of books on railroad economics published in this country. In addition, President Hadley had, as chairman of President Taft's securities commission, the very valuable opportunity to study at close range and in the broadest possible way the problems of American railroad finance. The addition of such a man to the councils of the New Haven will obviously be of the utmost importance to that property; but the recognition of this fact by the New Haven directors is a real step in advance in the conduct of railroad affairs by those who represent the owners of the railroads. The New Haven board is larger than most railroad boards and has on it an unusually large number of men who represent great wealth, invested not only in many other roads beside the New Haven, but also in other lines of business. The decision of these men to associate with themselves a man noted for his courage and ability to decide questions according to principle and not expediency is a good sign of the times.

IT is well known that the efficiency with which the Baltimore & Ohio is operated has been greatly increased within recent years. We publish on another page an article by C. C. Riley, general superintendent of transportation of that road, which clearly indicates how the increasing efficiency in its operation is being secured. Mr. Riley's article describes the methods that are being used to get better performance from freight cars. These methods, so far as the transportation department is directly concerned, are broadly of two kinds, investigation and supervision. The management first set out to learn what was wrong, and that is the very beginning of the work of increasing efficiency. Having located the shortcomings in methods, it has increased the official staff for the express purpose of correcting the faults detected. All this sounds simple enough. But to actually do the investigating and supervising necessary to make investigation and supervision count on a railway system as big as the Baltimore & Ohio involves a tremendous amount of hard, continuous, detailed work. And it is work of this kind which is imperatively needed in the operating departments of many railways in the United States. There is only one way to get it done, and that is to spend the necessary money for adequate supervision and then insist on supervision being adequate. One of the troubles with many railways is that their managements suffer from the illusion that the money they avoid spending by keeping down their expenditures for supervision actually is saved. The only way to make railway employees worth the high wages that they are now receiving and railway supplies and equipment worth the high prices they now cost is to employ enough capable officers in all the different ranks to get the maximum practicable results from every structure, every unit of equipment, every employee.

OF proposed amendments to the Standard Code of train rules some of the most sensible and most clearly expressed have been those formulated by the committee of the train dispatchers' association. We had occasion in connection with a former convention (June 28, 1912) to point out this fact, and it was again prominent in the report of the superintendents' convention at Chicago printed August 29, page 374. No one will say that those dispatchers acquired all their railroad knowledge in an office. But, as befits a true friend of the dispatchers, we feel bound to register a



vigorous "kick" against their proposal to make a rule directing enginemen to blow whistle blasts of eight seconds each. Have those committee men no friends living in the country, where whistle blasts, even of four seconds, are a great nuisance? In the cities the people repress the railroads, more or less, and unnecessary noise from engines is not so common as it used to be; but dwellers on the prairies deserve some consideration—likewise the passengers in the cars. A car in a train within 150 ft. of the engine is often made a partial bedlam to the passengers riding in it by a thoughtless engineman. And long blasts are not objectionable alone because of the complaints of pernicky neighbors; they are unnecessary from the railroad standpoint. Let any despatcher who has a buzzer at hand use it to make the highway crossing signal as recommended at Chicago, taking about 13 seconds—four, four, two, two; we venture to say that he will recommend any farmer to sell his farm if it is located near a whistling post where such whistle-signals are given frequently—unless the whistles are very soft ones. That is, either sell the farm or reform the railroad. Superintendents who have required the highway signal to be made quickly—all of the four blasts within two seconds—have found decided satisfaction in so doing. Other signals can be reformed with equal facility.

**T**HE recommendation that, where two roads are so near together that the whistle signals may be confused, the code for calling in flagmen shall be enlarged, so as to provide twice as many indications, is another point in the despatchers' conclusions which it is to be hoped will not prevail. Not that we should not take every possible means to preclude confusion; clear instructions must be had at any cost; but an amplified code is likely to cause as much confusion as it cures. The noise nuisance, from the neighbors' standpoint, comes in here, also; but that is not the main reason. A safe rule would be to do as has been done in some cases on four track lines: abolish entirely the use of the engine whistle for calling in the flagman. In the great majority of cases a mouth whistle can, with proper precautions and adjuncts, be made available; and at junctions such as the despatchers have in mind, telephones could in many cases easily be made available. The use of telephones, installed in boxes on posts along the road, is revolutionizing some features of train management, and committees who deal with train rules have a duty to see that the revolution does not proceed so rapidly as to leave them behind. The despatchers are to be commended for their common sense, their insight and their lucid presentation of their views; but their art has the weakness of its defects. They beat the world in doing a delicate business at long range; but if we do everything at long range we shall have to look out or we shall be guilty of as great a noise nuisance as is the coast artillery, when it fires cannon balls at targets six miles out at sea.

#### WEAK SPOTS IN DISCIPLINE.

**Q**UESTIONS concerning weaknesses in the discipline of trainmen on American railroads and of ways of curing such weaknesses constitute a staple topic for discussion. In a business where so many men are involved, with a multiplicity of bosses and sub-bosses, scattered over a territory extending hundreds of miles and performing exacting and delicate duties, some inefficiency is inevitable. The strict disciplinarian must be a man of vigorous backbone. The greatest weakening influence that haunts the railroad officer is sympathy for the unfortunate and the ignorant. In one aspect of the matter a lack of education or ability on the part of the boss may be looked upon as the chief fault in discipline, as, if he knows his job, he understands the danger of being influenced by sympathy or other unbusinesslike considerations. Undoubtedly, if our superintendents had been

more thoroughly and scientifically trained for their positions, the discipline of their men would be better. The influence of the brotherhood grievance committees weakens discipline many times because the sympathies of the committee men are in line with most of their legitimate arguments. Whether this sympathy of the professional grievers is or is not the worst influence in this department of railroad work, as often appears to be the case, need not be discussed at this time. Evidence of the deplorable fact is not easy to gather, for the officer who allows himself to be overborne by a too strenuous committee naturally conceals or disguises the fact as much as possible, and the committee men, on their part, are only too glad to let it appear that they won their case wholly by legitimate means. Whatever the apportionment of responsibility, the duty, of course, of every railroad officer as well as of every committee man is to act in all cases solely in the interest of the efficiency of the service, for safety and economy and to make the railroad popular with the public. Sympathy must take some other form than that of putting or keeping a man in a position that he is not fit to fill.

A very effective way of inculcating firmness and relegating sympathy to its rightful place would be to publish some of the numerous and instructive incidents of, actual life, with which railroad officers are acquainted; and we have made the foregoing observations as an introduction to a statement of two illustrative cases. These are given, by a well known superintendent, as follows:

An engineman against whose record were many debits for trivial acts of carelessness, such as being late in responding to call, running through switches in yards, running over Hayes derails, not cutting the engine off a heavy freight train in taking water, forgetting to examine bulletin boards and register for special orders, was finally dismissed from the service on account of his generally shiftless and careless behavior. After much parleying and many promises of reformation he was reinstated, first having been given a heart-to-heart lecture by the superintendent. A few days after he resumed work he went to sleep while pulling through a passing siding, on single track, and pulled out at the opposite end, in the face of an approaching train; and he was killed in the collision which followed. This was a case of misplaced confidence in the ability of a careless man to reform.

A passenger conductor who had a good record and who had been in the service for thirty years was dismissed for drinking while on duty, this being, so far as was known, his first offense. He stoutly denied that he was in the habit of drinking and maintained that on the occasion in question he had taken blackberry brandy as a medicine and had been overcome by its effect. He had a good reputation in the town where he lived and succeeded in getting letters asking for reinstatement from several clergymen, bank officers and substantial business men who had known him for years. The conductors' committee made a strong plea for leniency, and, considering his previous good record, he was finally reinstated. On the third trip which he made after his reinstatement he again got intoxicated and was again dismissed; and it was then found that he was addicted to intoxicants; and after that he was frequently seen intoxicated on the streets of the town where the clergymen and others had so beautifully eulogized his character and habits. This was a very unusual case of a man beginning the use of intoxicants after leading a temperate life for over fifty years, a case of misplaced sentiment toward a man with a favorable record of thirty years standing, and a previous good reputation as a citizen, but who went wrong in spite of everything.

The first of these two cases is to be classed as a tragedy—is it not? From so brief a statement it is not perhaps fair for either the editor or the reader to draw a final conclusion, but at least we have here a reminder of the elementary lesson that small derelictions surely show the tendencies which

result in larger ones. Nothing is plainer, in a great many cases, than that irrevocable removal from the service is the only suitable punishment for what are called minor offenses. A "promise" of reformation is buried out of sight by the fundamental maxim of human nature that "actions speak louder than words." The second case is one in which a superintendent would be tempted more readily to excuse himself; but the danger of allowing any relaxation of Rule G is well known, and it is safe to say that that particular superintendent, after that case, bore this in mind. False men who have honest (and innocent) friends constitute one of the constant danger points in the railroad officer's scheme of discipline, and the drink habit is one of the things which change honest men into false ones.

In contrast with these two cases the reader will be glad to see a couple of narratives, with a different ending, which we have received from superintendents A. and B. as follows:

I recall the case of Dickinson, an engineman whom I discharged. This action was taken only after a careful investigation and two hearings, at which three members of the committee were present. Some days after the case was settled these three committeemen came in to see me. At the very outset I asked them to define their attitude. "Do you come here claiming that there has been any element of unfairness or injustice in the decision of this case, or are you here simply because of your sympathy toward Dickinson's wife and children?" "Well," they said, "we thought that in view of —" I interrupted them at once, and repeated my challenge: "What facts or arguments do you wish to present? What flaws do you find in my decision?" Again they began about some alleged principle, as affecting such and such rules; and again I refused to listen; and finally they said that, to be frank, they would have to admit that sympathy

was the whole motive of their visit. They were not prepared to dispute a single point in my decision. "Sympathy," said I, "in a case like this, is a laudable sentiment. You cannot be more truly sorry for this man's family than am I, myself; but the safety of our trains is a matter of cold business, simple devotion to duty and faithful and intelligent carrying out of the rules. In no other way can we think of achieving even a moderate degree of success." And thus the case was settled.

Here is the case of Engineer Charles Jenkins. He was employed as fireman in December, 1902; promoted to engineman June, 1909. His discipline record contains four items, in substance as follows: February, 1910, one demerit mark for allowing injector discharge pipe to freeze and burst, making it necessary to send a relief engine. April, 1910, one demerit mark for derailment of engine. June, 1911, suspended ten days for responsibility for derailment. August, 1911, dismissed from the service for running past signals at a junction.

On the face of it this man's dismissal looks like severe discipline, but he was discharged for being generally incompetent as an engineman, and lacking in judgment and common sense. His discipline record does not show the narrow escapes from accidents which he had. But these narrow escapes were known to the superintendent, and finally that officer refused to take the responsibility of keeping the man in the service any longer. Very serious objection was raised by the committee representing the brotherhood, their position being that the company had no right to discharge a man without just cause; that is to say, until after he had been the cause of a train accident. But the superintendent, backed by his superior, took the position that he should not assume the responsibility of keeping such a runner in the service, it being perfectly evident that the man would have a serious accident, sooner or later. "And," says the superintendent, "I took the position that I did not propose to be accountable after the road foreman of engines and my assistants had refused to do so. The engineers' committee thought this was unfair. Then I offered to keep Jenkins in the service if they would take the responsibility; that is in the only way that they could, namely, if he had an accident, they were to consider themselves dismissed. The result was that the matter was dropped entirely and Jenkins left the service."

These cases carry their own lessons and need no amplification. In Dickinson's case the officer separated sympathy from "business" by his firmness in insisting on settling the first point first. In the case of Jenkins the arguments of the committee, whether based on sympathy or logic, or a mixture of the two, were, by the superintendent's bold proposal, quickly resolved into a shape where they had to stand the test of cold and lucid reason. The issue was changed into a form in which, apparently, it settled itself.

**ILLINOIS CENTRAL.**

INFINITE patience and courage are required to nurse a great railroad system through a period of misfortunes such as has been visited on the Illinois Central in the past two years. Possibly the heaviest demand is made on patience and courage when, just as things seem to have been partially straightened out, a further unforeseeable misfortune takes place, such as the floods during March and April of the past year. There were eight days in April when there was no connection between the north and south lines of the Illinois Central, and for weeks after that operation had to be carried on under extraordinary difficulties. It is small wonder, therefore, that if we compare the results obtained in 1913 with those obtained in 1911, a normal year, we find

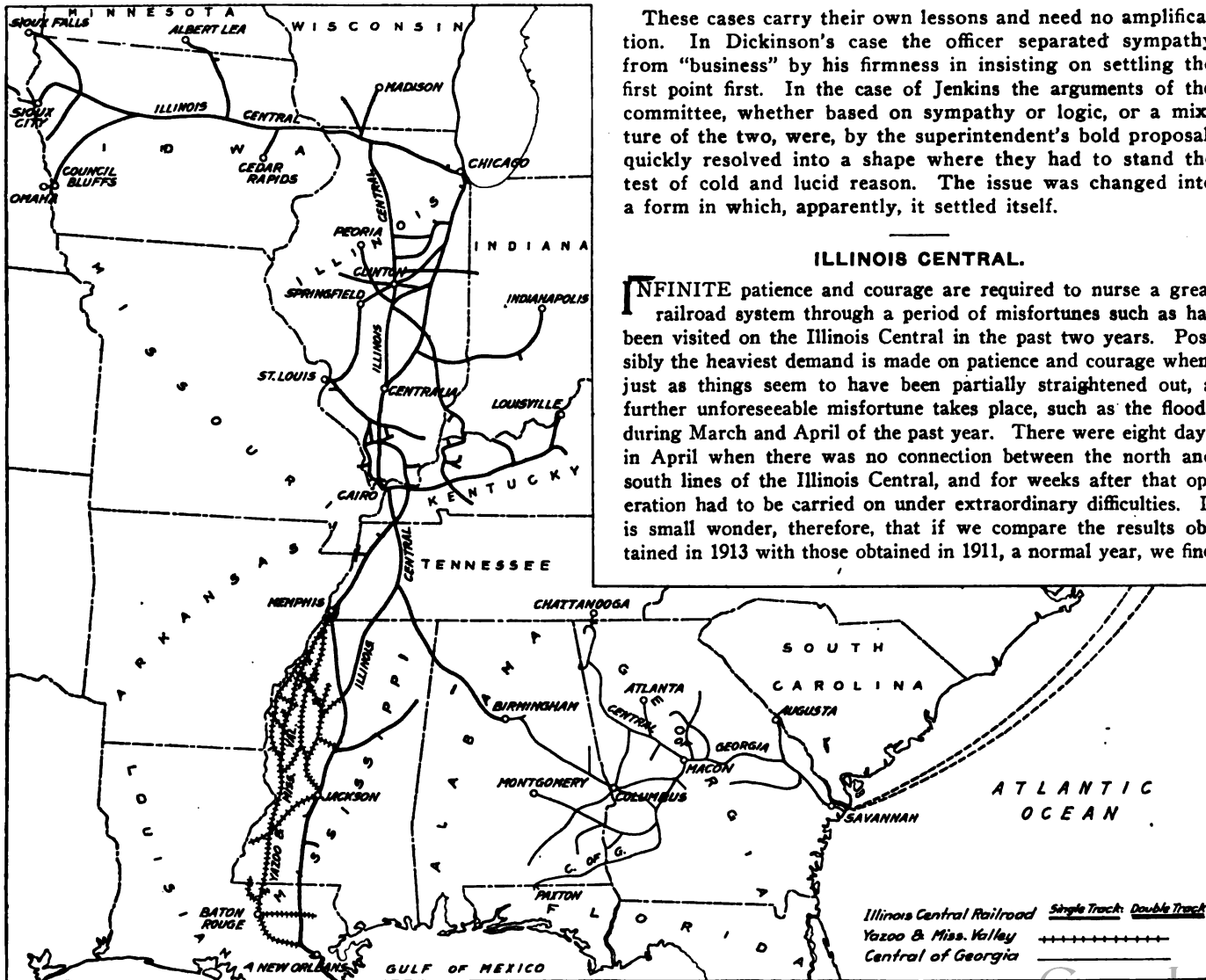

The Illinois Central and its Atlantic Coast Connection, the Central of Georgia.

that the Illinois Central has not yet regained its lost ground.

The directors showed both courage and wisdom in reducing the annual dividend rate from 7 to 5 per cent., the company paying a total of 6 per cent. in the fiscal year 1913 and earning it. Even so, however, the company's surplus account has been reduced to \$1,996,000, a figure which precludes—until it has been built up again—the possibility of paying dividends even in a period of temporary depression unless they are actually earned.

The recovery in general business and in gross revenue was good when compared with 1912, but when compared with 1911 reflects the abnormal conditions created by the flood. Total operating revenue amounted to \$64,281,000, or \$5,554,000 more than in 1912, and \$2,612,000 more than in 1911. This, of course, is by no means a normal increase for two years for a road like the Illinois Central, but probably will not compare unfavorably with the gain over the 1911 showing made by other roads that were affected by the flood.

Expenses, of course, were far higher in 1913 than in 1911, and were some higher than in 1912. From the table at the end of these comments it will be seen that the bulk of the increases in expenses occurred in expenditures for maintenance of way and for transportation. The total of all freight carried one mile increased 17.44 per cent. in 1913 over 1912, but only 8.3 per cent. over 1911; while transportation expenses were between 13 and 14 per cent. greater in 1913 than in 1911. Almost every single primary account under transportation expenses shows considerable increases in 1913 over 1911, but by far the greatest proportionate increases in cost are the yard expenses.

When we stop to recall that the main double track lines of the Illinois Central are worked more nearly to capacity, probably, than any other so great a mileage, with the exception of the Pennsylvania Railroad, the wonder is that the total break-in-two of these lines for ten days did not create far worse confusion and add far more to yard and other expenses than was actually the case. The explanation, of course, is that the operating force of the road simply lived 24 hours a day on the job during the flood period, and they refused traffic when they could not handle it. This also explains why the increase in total operating revenues was not as great as might have been hoped for.

This is the dark side of the picture. June, 1913, earnings were the best June earnings in the history of the company. The directors have stood behind the management; the management has steadily stuck to its guns; \$8,000,000 was raised through the sale of equipment trust certificates for the purchase of new heavy modern locomotives and large capacity freight cars; lighter-power and light cars that had probably been worked through the strike period, with just the bare repairs necessary to keep them going, have been scrapped; and despite congestion, floods, and the inevitable difficulties of holding an organization together after a great strike, the company has increased its train load and at least lived up to its own high standard of maintenance.

In 1913 the average train load of revenue freight was 407 tons, and of all freight, 482 tons. This compares with a revenue train load in 1912 of 356 tons, and in 1911 of 358 tons; and with a total train load of 427 tons in 1912 and 430 tons in 1911. Car loading averaged 22.82 tons per loaded car, as against 21.52 in 1912, 21.91 in 1911 and 21.96 in 1909. Revenue freight train miles increased but 4.08 per cent. over 1912, with an increase of more than 17 per cent. in ton mileage carried; and the number of loaded cars per train mile increased 6 per cent.

Last year 349 miles of electric automatic block signals were installed on the Illinois Central. More than 11 per cent. of all ties in track, including sidings, were renewed.

The Illinois Central has had for a number of years an unusually high credit, and while the troubles that the road has had to contend with in the past two years and the resulting decrease in the dividend rate have reduced the price at which Illinois stock is quoted, it is general money conditions rather than anything peculiar to the Illinois Central situation that has prevented the company from doing necessary long-term financing. At the end of 1913 the company had on hand \$2,234,000 cash, with \$23,751,-

000 of its own securities in its treasury. Total working assets were \$43,320,000 and total working liabilities, \$16,458,000. The working liabilities include \$6,500,000 loans and bills payable, the increase during the year in this account being \$600,000.

The following table shows the principal figures for operation in the fiscal year ended June 30, 1913, as compared with 1912:

	1913.	1912.
Average mileage operated.....	4,763	4,763
Freight revenue .....	\$45,589,299	\$37,881,766
Passenger revenue .....	13,455,884	13,337,562
Total operating revenues.....	64,280,903	58,727,272
Maint. of way and structures....	8,519,025	7,691,215
Maint. of equipment.....	13,952,654	13,857,549
Traffic expenses .....	1,320,583	1,400,942
Transportation expenses .....	24,743,324	23,653,249
General expenses .....	1,513,325	1,518,512
Total operating expenses.....	50,048,912	48,121,467
Taxes .....	2,903,551	2,685,730
Operating income .....	11,250,848	7,812,719
Gross income .....	17,250,200	12,183,478
Net income .....	6,575,113	3,466,448
Dividends .....	6,557,760	7,650,720
Surplus .....	17,353	*4,184,272

\*Deficit.

### CHICAGO & NORTH WESTERN.

ONE of the easiest ways for a railroad management to make a good showing is to have a comparison made with a previous poor showing, but the history of the Chicago & North Western definitely precludes the management from making a showing in this way. The substantial gain in gross, the smaller per cent. spent for transportation expenses, and the larger surplus earned in the fiscal year ended June 30, 1913, may, therefore, be taken at their full value. After the payment of 8 per cent. on the preferred stock and 7 per cent. on the common stock there was a surplus of \$3,775,000 in 1913, as compared with \$568,000 in 1912.

The Chicago & North Western operates nearly 8,000 miles of road. It has been called the Pennsylvania of the West, but this implied comparison is suggested rather by the standards of North Western service than by any similarity between the character of traffic or physical characteristics of the plant or density of traffic, except on the main lines of the North Western.

The North Western has a very large proportion of branch line mileage. It is a granger road, earning on an average about \$10,000 a mile (\$10,413 in 1913 and \$9,378 in 1912). The company does not show the tonnage of various classes of commodities in its annual report. The following figures are taken from its reports to the Interstate Commerce Commission for 1912, total tonnage, 37,265,642. The per cent. of each class of commodities is as follows:

Ores .....	19.27	per cent.
Bituminous coal .....	14.54	per cent.
Lumber .....	13.74	per cent.
Stone and sand .....	7.86	per cent.
Grain .....	7.63	per cent.

While, of course, there is not a large percentage of low grade tonnage, and we would not expect to find a very heavy train load, yet on the other hand, the Union Pacific and the Hill lines have considerably heavier train loads than the North Western. There are two explanations of this. The North Western, having such a large proportion of branch line mileage, would have a comparatively low average train load, even if it had developed very heavy train loads on main line traffic. As a matter of fact, however, the North Western's chief aim has not been so much the development of very heavy train loads as the development of business through good service.

An annual report does not reflect, except negatively, such a policy as this of the North Western. Such a policy, however, is of the utmost importance not only to the people who are served by the road, but, in the long run, to the road's security holders. With freight rates between competitive points necessarily the same on different roads, and where there is no competition, with railroads so largely at the mercy of local regulative and legislative bodies, the amount of traffic that a road can secure and its opportunities for development—comparatively unhindered by local hostility—depend to a very great extent on the

quality of the service rendered. The Chicago & North Western's enviable position and earning power are undoubtedly in a very considerable measure due to the pursuance of a fixed policy extending over a number of years of placing service on a par with economy.

The Chicago & North Western carries 731,000 ton miles per mile of road and 140,000 passenger miles per mile of road. Its revenues per unit of service are fair but not large. In 1913 the average revenue per ton per mile was 8.7 mills, comparing with 9.1 mills in 1912, and its average passenger rate was 1.85 cents in 1913 and 1.81 cents in 1912. The average haul of freight was 140 miles in 1913 and 138 in 1912.

The average train load for the whole road in 1913 was 348 tons. This is an increase of 16 tons over 1912, which is noteworthy. Put in another way it is even more striking, possibly. The total tons of freight carried one mile amounted to 6,282,900,000, an increase over 1912 of 22 per cent. The mileage of

following table shows the ratio of each class of expenses to total operating revenues:

	1913.	1912.
Maintenance of way and structures.....	13	12
Maintenance of equipment .....	13	12
Transportation expenses .....	1.6	1.8
Traffic expenses .....	38	41

Maintenance of way expenses were particularly heavy because the company did a good deal of renewal work. Light rails were replaced with heavier rails on 559 miles of track, the total cost of replacing in kind, of course, being charged to maintenance; the occasion of the replacement of these rails was used to strengthen ballast, renew ties, replace wooden structures with fills or culverts, and to generally bring the roadbed up to the standard. The wooden structures replaced by permanent work aggregated 6,243 ft.

Details of some of the betterment work and especially of extensions are mentioned in our construction columns, and in this

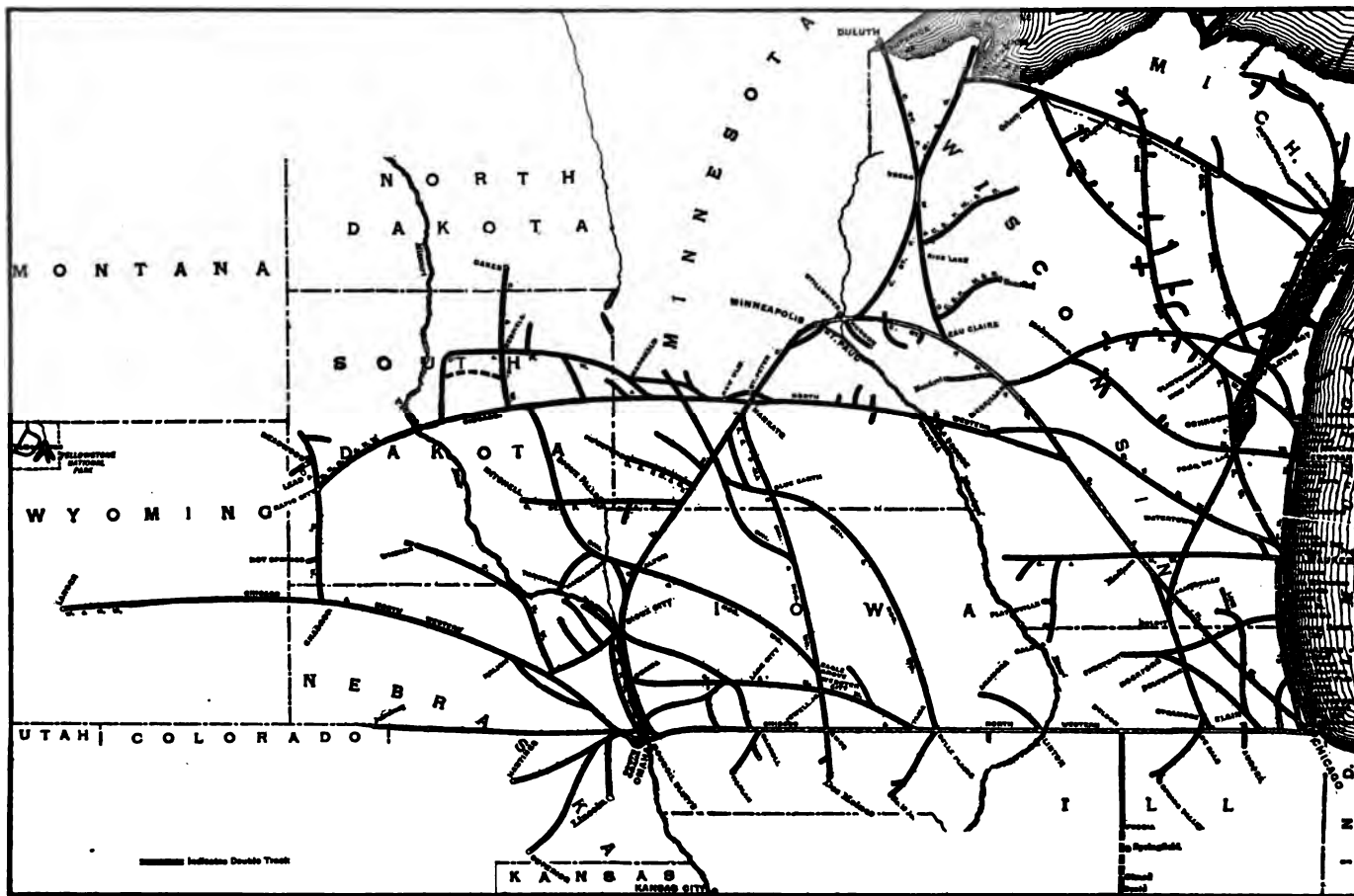

The Chicago & Northwestern System, Including the Omaha.

freight and mixed trains amounted to 18,056,000 in 1913, an increase of but 4.88 per cent. The average car loading per loaded car was 18.38 tons in 1913, an increase of 8.95 per cent. This is a substantial increase, but, on the other hand, there was a rather wide field for improvement.

Total operating expenses in 1913 amounted to \$58,253,000, which is greater by \$5,551,000 than the 1912 operating expenses. Of the increase, however, \$2,132,000 was in maintenance of way, \$1,999,000 in maintenance of equipment and but \$1,316,000 in transportation expenses. Thus in 1913 the company spent 19.74 per cent. of the total operating expenses for maintenance of way, 19.86 per cent. for maintenance of equipment and 55.35 per cent. for transportation expenses, while in 1912, 17.78 per cent. was spent for maintenance of way, 18.16 per cent. for maintenance of equipment and 58.68 per cent. for transportation expenses. The

connection it is worth noting that considerable progress was made with the installation of block signals. When the work now in progress is completed, 957 miles of road on the North Western will be equipped with automatic signals. The company is also installing telephones for train despatching and in a comparatively short time will have 2,173 miles of road so equipped.

The only capital securities that were issued during the year were \$5,700,000 equipment trust certificates, \$2,500,000 Des Plaines Valley bonds assumed and \$1,120,000 St. Paul Eastern Grand Trunk bonds assumed, the net increase in bonds outstanding being \$9,180,000. During the year there was an increase of \$1,138,000 in bonds held in the treasury, this amount having been certified by the trustee and turned over to the treasurer in exchange for bonds retired and for construction expenditures.

At the end of the year the North Western had on hand \$9,-

647,000 cash, with total working assets of \$46,189,000, against which there were working liabilities of but \$10,420,000. The North Western includes under its working assets \$10,337,000 Chicago, St. Paul, Minneapolis & Omaha stock, which might apparently more properly be included under investments, since it is hardly likely that the North Western would consider any sale of its controlling interest in the Omaha.

The following table shows the principal figures for operation in 1913 as compared with 1912:

	1913.	1912.
Average mileage operated.....	7,974	7,859
Freight revenue .....	\$54,661,588	\$46,691,540
Passenger revenue .....	20,557,623	19,555,567
Total operating revenues .....	83,035,921	73,698,592
Maint. of way and structures....	11,501,186	9,368,721
Maint. of equipment .....	11,568,496	9,569,853
Traffic expenses .....	1,348,982	1,340,086
Transportation expenses .....	32,241,258	30,924,938
General expenses .....	1,592,858	1,498,245
Total operating expenses .....	58,252,780	52,701,843
Taxes .....	3,597,160	3,422,838
Operating income .....	21,197,277	17,540,872
Gross income .....	24,660,769	20,922,766
Net income .....	14,875,013	11,724,540
Sinking fund .....	199,991	257,209
Dividends .....	10,899,615	10,899,615
Surplus .....	3,775,408	567,716

#### CHICAGO, ST. PAUL, MINNEAPOLIS & OMAHA.

THE Chicago, St. Paul, Minneapolis & Omaha operates 1,747 miles of road in Wisconsin, Minnesota, Iowa, South Dakota and Nebraska. Of this mileage 157 miles is double track. The road has a bonded debt of but \$22,400 per mile, and there is outstanding \$29,819,000 stock, of which the Chicago & North Western owns \$14,920,000. Dependent as it is for traffic very largely on products of agriculture, and supplies and manufacturers shipped in to the agricultural communities which it serves, the Omaha's prosperity is governed from year to year by the crop conditions in its territory.

In the fiscal year ended June 30, 1913, crops throughout the states served by the Omaha were fairly good and compared very favorably with the poor year 1912. The Omaha earned in 1913 \$16,993,000, as against \$15,135,000 in 1912. Operating expenses amounted to \$11,887,000 last year, as against \$10,466,000 the year before. The operating ratio, therefore, was 69.95 in 1913 and 69.15 in 1912.

The total ton mileage of freight carried in 1913 was 1,263,000,000, an increase of 15.64 per cent. The amount received per ton per mile, however, decreased from 8.7 mills in 1912 to 8.6 mills in 1913.

The Omaha was able to show a larger average train load and better car loading not only when compared with 1912, but also when compared with 1911. The train load in 1913 was 276 tons; in 1912, 249 tons, and in 1911, 274 tons. The carload per loaded car was 18.99 tons in 1913, 17.62 tons in 1912 and 17.33 tons in 1911.

Like the North Western, the Omaha spent considerably more for maintenance in 1913 than in 1912. For maintenance of way and structures the Omaha spent \$2,208,000, an increase over 1912 of \$524,000. The largest single increase was in the expenditure for ties, on which nearly twice as much was spent in 1913 as in 1912. There was also, of course, more spent for roadway and track, and there was \$99,000 more spent on bridges and \$69,000 on buildings. Maintenance of equipment in 1913 cost \$2,189,000, an increase over 1912 of \$392,000, the largest single item of which was the amount spent for freight train car repairs.

At the end of 1913 the company had on hand \$2,413,000 cash, with total working liabilities of \$2,771,000. Working assets, in which the Omaha includes its own preferred and common stock in the treasury and bonds of the Minneapolis Eastern, totaled \$9,619,000. During the year there was \$2,500,000 debenture bonds sold, and the company spent a total of \$4,336,000 for additions and betterments and new equipment.

The following table shows the principal figures for operation in the fiscal year ended June 30, 1913, as compared with 1912:

	1913.	1912.
Average mileage operated.....	.....	.....
Freight revenue .....	\$10,857,207	\$9,478,792
Passenger revenue .....	4,984,595	4,551,594
Total operating revenues.....	16,993,005	15,135,426
Maint. of way and structures....	2,208,294	1,684,728
Maint. of equipment .....	1,188,946	1,796,694
Traffic expenses .....	348,515	320,889
Transportation expenses .....	6,746,792	6,283,268
General expenses .....	394,915	380,637
Total operating expenses .....	11,887,461	10,466,216
Taxes .....	832,263	782,846
Operating income .....	4,268,469	3,881,631
Gross income .....	4,504,272	4,122,304
Net income .....	2,278,933	2,084,603
Dividends .....	2,086,910	2,086,910
Surplus .....	*2,302	192,023

\*Deficit.

#### NEW BOOKS.

*Foreign Markets for Railway Supplies and Equipment.* Size 6 in. x 9 in.; 224 pages. Published by the Bureau of Foreign and Domestic Commerce, Washington, D. C. Price 25 cents.

This book will be found invaluable by the exporter of railway materials and should do much to widen the market for American products of this nature. Hitherto manufacturers have been greatly handicapped by the lack of knowledge of foreign market situations and the difficulty of reaching the proper railway officers. This book treats every country in the world separately and gives the most valuable information regarding each. This information includes a list of the railways of the country, both in operation and under construction, together with the names and addresses of the officers in charge of purchases; facts and figures regarding the amount and types of rolling stock in service; facts regarding the local construction and purchase of equipment; mention of the countries from which equipment is imported; and statements regarding the opportunity for American exporters.

*Rules of Management.* By William Lodge, president of the Lodge & Shipley Machine Tool Company. Bound in cloth. 140 pages. 5 in. x 8 in. Published by the McGraw-Hill Book Company, 239 West 39th street, New York. Price \$2.

In his foreword, Mr. Lodge states that when he decided to relinquish the active management of the Lodge & Shipley Machine Tool Company and let a younger generation take up the reins, he realized what would probably happen if he simply handed them over to others who had never learned how to drive. He therefore endeavored to see what could be done to prevent the immediate development of a new set of conditions with which the organization he had built up would not be able to cope. In carrying out his plan of teaching his subordinates to handle things, the record of his personal experience, put in the form of rules and comments, was printed for the information of the succeeding manager of the shop. This work is the result of the desire to give in a permanent written form a knowledge of facts and schemes of organization that would enable the next manager to carry on his work with a feeling that he was on sure footing. These instructions may also be found applicable in many lines of machine building, and they have therefore been printed for general distribution. In this book the duties and work of each department are outlined in some detail and there are separate chapters for each class of employees from the general manager to the janitor and watchman. These rules and instructions throughout are excellently worded, are filled with common sense and are thoroughly practical in their application. Although intended for the machine building industry the principles of good management in the abstract are so well understood and have been so thoroughly interwoven throughout the whole series of instructions that they are applicable to practically every manufacturing activity.

# INCREASING FREIGHT CAR PERFORMANCE.

Methods of Investigation and Supervision Being Used on  
Baltimore & Ohio to Reduce Expenses and Increase Results.

By C. C. RILEY,

General Superintendent of Transportation, Baltimore & Ohio.

In a most complete and comprehensive paper Mr. L. F. Loree has given the distribution of time of a typical freight car movement, showing that the average trip of a freight car consumes nearly fifteen days, of which the railroad is responsible for 63.7 per cent. and the shipper for 36.3 per cent. Others have enumerated the principal things that slow up car movement. Circular No. 1316 of the American Railway Association contains eight timely suggestions toward securing increase of available car supply. This article deals briefly with methods already in successful operation on the Baltimore & Ohio Railroad for reducing delays to cars and increasing car performance.

The generally accepted unit of measure of car performance is the average miles per car per day. It should be remembered, however, that this unit of measure can be used properly only in comparison of operations of a road with itself. On account of conditions surrounding each road's operations a comparison of one road with another is unreliable and of no great value. The chief factor in determining the average miles per car per

each grand division and each official interested in any way is required to have one in his possession.

In order to determine progress a weekly car location statement is made showing the number of each class of system cars and of foreign cars on each division. Comparison is made of cars on hand with business done to determine roughly if too many cars are in the possession of any division.

A statement showing the performance of the individual division is prepared each week and furnished to all operating officials from the general manager to the trainmaster. This statement shows for each division its best previous performance, together with performance for the current period. It also shows car miles, car days, per diem and what saving would have been effected had the best performance been maintained. Since this report was put into use the efforts of the several divisions have been greatly stimulated; several divisions have exceeded their best previous records. A copy of the report for divisions of dissimilar traffic conditions is given below:

Divisions.	Period.	Avg. miles per day.	Percentage of maximum avg. miles per car per day.	Car miles.	Car days.	Per diem.	Had maximum performance been maintained per diem would have been		Per diem loss due to slower movement
							Days.	Amount.	
A .....	Nov., 1912	56.4							
	July, 1913	48.1	85.3	3,192,123	66,377	\$29,869.65	56,598	\$25,469.10	\$4,400.55
	Aug., 1913	50.8	90.1	3,314,152	65,228	29,352.60	58,762	26,442.90	2,909.70
B .....	Jan., 1913	15.9							
	July, 1913	15.4	96.9	4,764,323	308,926	139,016.70	299,643	134,839.35	4,177.35
	Aug., 1913	16.3	102.5	5,050,455	309,078	139,085.10	317,639	142,937.55	*3,852.45
C .....	April, 1912	67.7							
	July, 1913	64.8	95.7	13,245,571	204,396	91,978.20	195,651	88,042.95	3,935.25
	Aug., 1913	64.9	95.9	14,463,951	223,010	100,354.50	213,648	96,141.60	4,212.90
D .....	Feb., 1913	14.1							
	July, 1913	11.3	80.1	2,454,292	216,033	98,114.85	174,063	78,328.35	19,786.50
	Aug., 1913	11.3	80.1	2,678,298	236,040	106,218.00	189,950	85,477.50	20,740.50

\*Gain. Best previous record underscored.

day is the average haul of the loaded car. The road with a long average haul should have a high average car performance, whereas the road with a short average haul will have a low car performance. Roads with high average miles per car per day do not necessarily render the most efficient service. Frequently a road with a low average mileage per car per day does better than a road with higher average mileage per car per day. Some of the potent factors which retard car movement are demurrage, average haul, reconsignments, minimum load, industrial switching. An increase in industrial switching decreases average miles per car per day, as cars so handled are not credited with mileage.

## A CAMPAIGN OF EDUCATION AND SUPERVISION.

In order to secure better performance the Baltimore & Ohio has entered upon a campaign of education and supervision covering not only specific handling of cars, but of transportation matters generally. At stated intervals line officials, including assistant superintendents and trainmasters, come to the general office and are given several weeks' special instruction. They are drilled in detailed workings of the transportation and accounting departments. The reasons for doing things in certain specified ways and the disposition made of various reports prepared on the division are explained. During their stay talks are given them by officials of the operating, accounting and signaling departments. Division officials who have had the advantage of these instructions render more efficient service.

For each ten day period a car bulletin is issued showing the general trend of business, the demand for each class of cars and how surplus cars should be handled. A bulletin is made for

Wrong conclusions and improper action frequently result from incorrect reports. To insure against this, reports received from divisions and grand divisions are carefully checked periodically in the transportation and record offices to determine their accuracy.

## ENLISTING ASSISTANCE OF SHIPPERS.

Car supply has been materially increased by enlisting the assistance of shippers. The attention of patrons is called to delays in loading and unloading when greater than the average. This is usually done by letter and it is believed great good has resulted therefrom. Patrons as a rule respond to appeals of this kind. Their assistance is further solicited through visits and letters. Operating officials are urged to keep in personal touch with the patrons of the road, as more can be accomplished thereby. Several times during the season individual letters are written to the heaviest users of cars. The latest one reads as follows:

In order to minimize the effect during the coming fall of impending car shortage, the earnest support of patrons is solicited. Everything possible will be done by the railroads to lessen the effects of car shortage, but the full measure of efficiency cannot be secured without the help and hearty co-operation of car users.

As has been demonstrated by experience, car supply can best be conserved by unloading and loading cars promptly and notifying the agent immediately when this is done; by ordering empty cars as far in advance as possible and also specifying destination and route of shipment; by ordering only cars actually required for immediate loading; by loading cars to full carrying capacity; by loading cars in such manner as will avoid necessity for trimming, readjustment or transfer of lading enroute; by loading individual cars to points specified when order is placed for cars; by limiting the use of reconsigning privilege; by arranging for acceptance of freight immediately upon arrival at destination.

A car shortage is detrimental to the interests of both patron and railroad. Will you not kindly lend your efforts to secure the greatest possible use from available equipment?

It is felt that the Baltimore & Ohio has done its share in providing equipment for increasing business. Since January, 1910, 664 locomotives and more than 29,000 freight cars have been bought.

While the axiom "The time to move a train is when there is a train to move" has not been realized, the policy of the management is to that end. This axiom is just as applicable to yard as to road movement. In many large yards night pick-up trains could be used to advantage to move cars unloaded during the day and to place cars for next day's loading and unloading. A great stride would be made in eliminating car shortages if the best possible movement were given cars in yards.

Car shortages are frequently caused by unwarranted hoarding of cars for anticipated future requirements. This action is rarely justified except on the heavy originating lines. The greatest shortages often occur with the largest number of cars on line and the greatest efficiency is usually secured when the fewest cars are available. A large road in the Southwest maintains a car shortage during periods of heavy demand and thereby secures its best car performance. Transportation officials should have no hesitancy in disposing of cars not actually needed for the handling of business. The presence of unnecessary cars on a road invites relaxation of effort. If a road requiring 50,000 cars to do its normal business had 100,000 cars on hand the greater part of the 100,000 cars would be considered necessary and reduction of that number to 75,000 cars would cause a shortage until there was a readjustment of conditions. A further reduction to 50,000 cars, the number actually needed, would cause another shortage which would last until conditions were adjusted. Greater economy of operation and efficiency of service can be secured by handling fewer cars more promptly.

In figuring on successful operation it is presupposed that a sufficient amount of power is in good order and that track is in first-class condition. These two things are essential. Contingencies often arise which make it necessary to borrow from the future, but this procedure is costly. Equipment should be ready before the beginning of the maximum fall business, and the number of bad order cars should be kept as near 3 per cent. of the total cars on line as is possible. When the heavy traffic season is entered upon without proper preparations being made as regards power, cars and track, the conditions are difficult to overcome during that season.

In former years many cars were rejected as unfit for loading because of alleged defects. Last fall at the beginning of the grain movement nearly half of the cars offered for grain loading were rejected. Proper education of both shippers and railroad inspectors, and the liberal use of lumber for repairs and of paper or muslin for lining, resulted in the acceptance of more than 90 per cent. of cars previously classed as rough box and unfit for grain.

Decided progress has been made in solving the company material question. On the Baltimore & Ohio it is required that company material shall be unloaded within 48 hours, and this is done except in unusual cases.

#### POSITIONS CREATED TO INCREASE SUPERVISION.

To produce greater transportation efficiency two positions were created, namely, supervisor of transportation and supervisor of terminals. Supervisors of transportation are selected by the general manager and report to the general superintendent of transportation. Other things being equal supervisors of transportation are chosen from subordinate officers previously selected for advancement. These positions have the greatest educational advantages and are broadening in their administration; a year's experience to one of the proper mental makeup produces an ideal superintendent. It is intended as far as possible to give future superintendents the benefit of this training. As transportation is the big end of operation it is important that officials who handle the details should have proper transportation train-

ing and be in full accord and sympathy with the desires of the management. The best results cannot be secured without intelligent support of the division officials.

A supervisor of transportation with the necessary assistants is assigned to the territory of each general superintendent and to all practical purposes is a member of his staff, performing any duty of a transportation nature. In general, the duty of the supervisor of transportation is to supervise all matters pertaining to transportation and to study the needs of his territory with a view of improvement. Matters needing correction are taken up with proper local officials or with the general superintendent. Supervisors of transportation being men of high grade are available for emergencies. The specific duties performed by themselves and assistants are as follows:

1. Check of Division:
  - (a) Car delays including cars loaded with company material.
  - (b) Proper use of cars.
  - (c) Proper handling of l. c. l. freight and freight house accumulations.
  - (d) Making of correct reports.
2. Check of Yard Conditions:
  - (a) Congestions.
  - (b) Waybill boxes.
  - (c) Handling of home route cards and empty car waybills.
  - (d) Making of on-hand reports to see that they are complete and all cars accounted for.
  - (e) Making of correct reports.
3. Operation of pick-up and local trains for proper method of handling cars and freight.
4. Check of Division Car Distributor:
  - (a) Proper handling of cars.
  - (b) Check of on-hand reports.
  - (c) Comparison of telegraphic car report, empty car interchange report, telegraphic loading report and on-hand report.
  - (d) To see if car distributor is overworked or assigned duties not properly his.
  - (e) Making of correct reports.
  - (f) Check car order book.
5. To ascertain if trainmasters, assistant trainmasters, yardmasters and yard clerks have copies of current car bulletins.
6. To keep in close touch with officers of divisions and grand districts.
7. Special duties that may be assigned.

Supervisors of terminals report to the general manager and exercise advisory supervision over terminals. When assigned to a particular place upon request of the general superintendent they are given power to act. This position was created as an experiment. The results so far obtained have justified the experiment. It is from the yards that the greatest results must come. Probably the majority of large terminals in this country are inefficiently operated because of lack of proper information and supervision, which are the essence of operation. Without them there are no such things as efficiency and economy. But how few yards have them! At the present time the details of a scheme for destination classification are being worked out whereby at classification yards selected, cars are switched into solid trains for specific destinations and handled with decreased cost and increased efficiency.

#### IMPROVING YARD OPERATION.

Sufficient serious thought has not been spent on the improvement of yard operations, and the real advances have been few. The standards and working conditions of yardmasters and yard clerks have changed but little in the last twenty years. If efficiency were made the chief goal to be attained the methods of yard operation would soon be revolutionized.

The yard audit has been used to good advantage in yards performing below normal. It is difficult to demonstrate to yard officials that their operations are not good. This can soon be done by the yard audit. These audits cover weekly periods and show detentions due to patrons as well as transportation delays. Frequently these figures are questioned where they show bad

conditions. In such cases all data are turned over to the division officials to check. The operation of the yard audit for several weeks usually results in a noticeable improvement in reduction of delays.

Through a weighing bureau established a few years ago weights of practically all carload freight are secured. Through close watching of scale reports and the taking up with shippers of all cases of loading under carrying capacity of cars a great saving has been effected in equipment. About two-thirds of the tonnage of this road is coal. To overcome the difficulty heretofore experienced of overloading cars with coal of high specific gravity and underloading cars with coal of low specific gravity a chart is now in course of preparation for the benefit of shippers, showing the capacities in pounds and cubic feet of all classes of cars used; weight of coal per cubic foot from each district; and amount of lading needed to insure full carrying capacity. Some grades to secure full tonnage need only to be loaded level full; other grades need to be loaded only slightly above level; in the lighter grades it is necessary to pile to fullest extent to load to carrying capacity.

**LOADING OF MERCHANDISE CARS.**

Prior to 1910 too many merchandise cars were lightly loaded. Through a reform instituted that year loading of this class of cars was increased 40 per cent. in a little over three years. About a year ago the following methods were prescribed for the handling of l. c. l. freight:

1. The regardless-of-quantity cars was abolished.
2. A minimum of 10,000 lbs. was established for cars loaded on a division destined to stations on other divisions.
3. A minimum of 5,000 lbs. was established for cars loaded on a division to stations on same division.
4. Way-cars in local freight trains are handled without minima.

A campaign for improved handling of l. c. l. freight resulted in a saving of nearly 65,000 box cars during the six months' period ended March, 1913. These 65,000 cars enabled the Baltimore & Ohio to handle business which it otherwise could not have handled. As a result this road passed through a very heavy traffic period with practically no loss of business requiring box car equipment. A supervisor of transportation has been assigned to the study of the handling of l. c. l. freight with a view of giving better service, using fewer cars and effecting economies. Great results are anticipated from this bureau, but as Rudyard Kipling would say, that is another story.

**SPECIFICATIONS AND RULES FOR DOUGLAS FIR CAR MATERIAL.**

The grading committee of the West Coast Lumber Manufacturers' Association recently met to consider recommendations for changes in the grading rules. The matter of a change in the rules governing car material was carefully considered and the following rules were adopted by the association to supplement all other commercial grading rules on car material:

**GENERAL INSTRUCTIONS FOR GRADING.**

1. All lumber is graded with special reference to its suitability for the use intended.
2. With this in view, each piece is considered and its grade determined by its general character including the sum of all its defects.
3. The defects in lumber are to be considered in connection with the size of the piece, and for this reason wider and longer pieces will carry more defects than smaller pieces in the same grade.
4. Lumber must be accepted on grade in the form in which it was shipped. Any subsequent change in manufacture or mill work will prohibit an inspection for the adjustment of claims except with the consent of all parties interested.
5. A shipment of any grade must consist of a fair average

of that grade and cannot be made up of an unfair proportion of the better or poorer pieces that would pass in that grade.

6. All dressed lumber shall be measured and sold at the full size of rough material used in its manufacture.
7. All lumber 1 in. or less in thickness shall be counted as 1 in. thick.
8. All car material must be shipped in lengths specified or multiples thereof.
9. On all 1 in. D. & M., tongue must not be less than 3/16 in. wide.
10. Defects in rough stock caused by improper manufacture and drying, will reduce the grade, unless they may be removed by dressing such stock to standard sizes.
11. On clear strips, if sold in the rough dry, thickness must not be less than 1/16 in. over the finished size, nor width less than 5/16 in. less than the rough size; if green, not less than 1/16 in. under the rough size in thickness, and 1/8 in. less in width than the rough size.

12. All select common and common sold in the rough must be sawn full to sizes ordered, but natural shrinkage in transit shall not be considered a defect. Sizes under 6 in. in width shall measure full when green, and not more than 1/8 in. scant when dry or part dry. Sizes 6 in. to 12 in. in width shall measure full when green and not more than 1/4 in. scant when dry or part dry. Sizes 13 in. to 16 in. in width shall measure full when green and not more than 3/8 in. scant when dry or part dry.
13. 1 x 4 and 6 in. strips ordered S2S or S2S1E for re-running shall measure not less than 3/8 in. scant in width and 3/16 in. in thickness.

**STANDARD LENGTHS.**

14. Car siding—8, 9, 10 and 12 ft. or multiples.
15. Latitudinal roofing—5 and 6 ft.
16. Car lining and longitudinal roofing—8, 9, 10, 12, 14, 16, 18 and 20 ft. or multiples of 10 ft. and under.
17. Car decking—9 and 10 ft. or multiples.
18. All orders shall be shipped in the standard lengths called for, unless otherwise specified, but no lengths of car siding, lining or roofing shall be shipped except in the length specified or multiples thereof. Those who do not desire stock shipped in the multiple lengths should so specify. Fractional lengths are figured at the next longer standard length.

**DEFECTS.**

19. Recognized defects are knots, knot holes, splits, checks, wane, rot, rotten streaks, pin and grub worm holes, dog and pickeroon holes. Pitch seams or shakes, pitch pockets, chipped, torn and loose grain; solid pitch, stained heart, sap stain and imperfect manufacture.

**KNOTS.**

20. Knots shall be classified as pin, small, standard and large as to size; round and spike as to form; and sound, tight, loose and rotten as to quality.
21. A pin knot is not over 1/2 in. in diameter.
22. A small knot is not over 3/4 in. in diameter.
23. A standard knot is not over 1 1/2 in. in diameter.
24. A large knot is any size over 1 1/2 in. in diameter.
25. A round knot is oval or circular in form.
26. A spike knot is one sawn in a lengthwise direction.
27. A sound knot is red and its fiber must be closely interwoven with the grain of the wood.
28. A tight knot may be either red or black and is so fixed by growth or position that it will retain its place in the piece.
29. A loose knot is one not held firmly in place by growth or position.
30. A rotten knot is one not as hard as the wood it is in.
31. The mean or average diameter of knots shall be considered in applying or construing these rules.

**SAP.**

32. Bright sap shall not be considered a defect in any of the grades.



33. Sap stains shall not be considered a defect in any grade below No. 2 clear.

34. Discoloration of heart wood or stained heart must not be confounded with rot or rotten streaks. The presence of rot is indicated by a decided softness of the wood where it is discolored or by small white spots resembling pin worm holes.

#### PITCH.

35. Pitch pockets are openings between the grain of the wood containing more or less pitch and surrounded by sound grain wood. In determining the seriousness of the pitch pocket as a defect, both its width and length must be considered; the tighter the pocket the longer it may be. Size and number of pockets admissible in any piece must be left largely to the judgment of the grader and a reasonable deviation from the number of pockets specified in the rules will be permissible.

36. Pitch shakes are clearly defined openings between the grain of the wood, are either filled with granulated pitch or not, but in either case are a serious defect and must not be admitted in any grade.

37. Pitch streak is a well defined accumulation of pitch at one point in the piece and when not sufficient to develop a well defined streak, or where fiber between grains is not saturated with pitch, it shall not be considered a defect.

38. A small pitch pocket is not more than  $\frac{1}{8}$  in. in open width and not over 3 in. long.

39. A medium pitch pocket is one not over  $\frac{1}{4}$  in. in open width and not over 8 in. long.

40. A large pitch pocket is one more than  $\frac{1}{4}$  in. in open width and not over 8 in. long.

41. A scab pitch pocket is one in a flat grain piece not more than  $\frac{1}{8}$  in. deep,  $\frac{3}{4}$  in. wide and 3 in. long.

#### GRAIN.

42. Chipped grain consists in part of the surface being chipped or broken out in small particles below the line of the cut and as usually found should not be classed as torn grain and shall be considered a defect only when it unfits the piece for the use intended.

43. Torn grain consists in a part of the wood being torn out in dressing. It occurs around knots and curly places and is of four distinct characters: slight, medium, heavy and deep.

44. Slight torn grain should not exceed  $\frac{1}{32}$  in. in depth.

45. Medium torn grain not more than  $\frac{1}{16}$  in.

46. Heavy torn grain not more than  $\frac{1}{8}$  in.

47. Deep torn grain, any torn grain more than  $\frac{1}{8}$  in.

48. Wane is bark or lack of wood on the edges of lumber, from any cause.

#### DETAILED RULES FOR GRADING CAR MATERIAL.

49. No. 2 clear and better V. G. 1 x 4 and 6 in. (car siding, lining, etc.)—Angle of grain no less than 30 deg. Will admit any three of the following defects or their equivalent of combined defects on the face side, based on 10 ft. lengths: Slight torn grain, small pitch pockets that do not extend through the piece, sound pin knots. If specified S2S, rough spots on the back side are permissible if the piece is of uniform thickness.

50. No. 2 clear and better F. G. 1 x 4 and 6 in. (car siding, lining, longitudinal roofing, etc.)—Will admit any three of the following defects or their equivalent of combined defects on the face side, based on 10-ft. lengths: slight torn grain, small pitch pockets that do not extend through the piece, scab pitch pockets, sound pin knots, sound small knots or their equivalent of combined defects. If specified S2S, rough spots on back side permissible if the piece is of uniform thickness.

51. No. 2 clear and better, mill run as to grain.—Apply the same rules as on flat grain and vertical grain.

52. Latitudinal roofing, 1 x 4 and 6 in.—Same as No. 2 clear and better V. G. and F. G., except will allow two defects for each 5 or 6 ft. in length.

53. No. 3 clear 1 x 4 and 6 in. (box car lining, etc.)—May be either flat or vertical grain. Red, yellow, or silver fir. Must be tight-knotted stock. Will admit of torn grain and many contain five pin or three small knots or one standard knot, or five small or two medium pitch pockets, which may extend through the piece, in any continuous five feet of the length of the piece, or their equivalent of combined defects.

54. No. 2 clear and better V. G. 1½ and 2 x 6 and 8 in. (car decking, etc.)—Will admit any three of the following or their equivalent of combined defects on the face side: medium torn grain, medium pitch pockets that do not extend through the piece, sound small knots in a 9 or 10-ft. piece. Rough spots on the back side permissible if the piece is of uniform thickness. On D&M and shiplapped stock a 7/16 in. or ½-in. tongue or lap may be  $\frac{1}{8}$  in. scant in width on occasional pieces.

55. No. 2 clear and better F. G. 1½ and 2 x 6 and 8 in. (car decking, etc.)—To be graded the same as V. G. except that scab pitch pockets will be admitted.

56. Select common decking—Will admit heavy torn grain, heart stain, any number of sound standard knots, or medium pitch pockets that do not extend through the piece, or any combination of the above with minor defects. On D&M and shiplapped stock a 7/16-in. or ½-in. tongue or lap may be  $\frac{1}{8}$  in. scant in width on occasional pieces.

57. No. 1 common decking—Will admit heavy torn grain, any number of tight large knots, or medium pitch pockets that do not go through the piece, or minor defects. On D&M and shiplapped stock a 7/16-in. or ½-in. tongue may be  $\frac{1}{8}$  in. scant in width on occasional pieces.

58. Select common (car sills, framing, etc.)—Will admit of heavy torn grain, any number of tight knots not more than one-fourth the width of the piece in diameter, if not in clusters, medium pitch pockets, heart stain or minor defects.

59. No. 1 common (car sills, framing, etc.)—Will admit heavy torn grain, any number of tight knots, not more than one-third the width of the piece in diameter, any number of pitch pockets, heart stain, slight wane, or minor defects.

ELECTRIFICATION OF RAILWAY THROUGH THE APENNINES.—The Minister of Public Works of Italy has approved the proposed electrification of the railway between Sampierdarena, Genoa, and Ronco, in Liguria, Italy, on the Genoa-Milan and Genoa-Turin line of the Italian State Railway. The undertaking of electrifying this road will necessitate an expenditure of about \$1,200,000. Plans of work projected in connection therewith have been officially approved. As this railway is already partly electrified—that is, from Pontedecimo to Busalla—over the Giovi Pass, the new undertaking will be to connect Sampierdarena and Pontedecimo by electric railway, and to likewise connect Busalla and Ronco. This will electrify the larger part of the railroad from Genoa through the Apennine mountains. It is expected that the line will be in operation electrically by March, 1914. Unlike the present system of electric railway now in operation over part of this road, for the new project electrical power will be provided by a private company, arrangements already having been made with the Società Forze Idrauliche della Maira. The total distance of the electric railway from Sampierdarena to Ronco, including that already in operation, will be about 16½ miles, the two parts to be built being about 10 miles long and that in operation being about 6½ miles long. Electric locomotives on the railroad through the Apennines were made by the Società Italiana Westinghouse, of Vado, Liguria. There are at present 50 electric locomotives on the Italian State Railways, more than 25 of these locomotives are being used on the Giovi. Five new electric locomotives were ordered for the Italian State Railways last year from the Tecnomasio Italiano Brown-Boveri, of Milan, manufacturers of machines, etc.

# ADOPTED DESIGN OF THE QUEBEC BRIDGE.\*

Discussion of Elements Considered in Designing the Longest Span in the World by Member of the Board of Engineers.

By RALPH MODJESKI,  
Consulting Engineer.

The clear height of the Quebec bridge above high water was fixed by the navigation interests at 150 ft., and the length of span 1,800 ft., is entirely due to the physical conditions of the crossing. The stream at this point is narrow and deep, the depth in the center being about 190 ft. The current velocity at ebb tide is very high—about nine miles per hour. Very heavy ice runs at times and tends to gorge. The bed rock, as shown

expensive structure will afford sufficient advertisement and publicity to compensate for the additional expenditure.

A project to build a large bridge at Quebec, presumably in the same location as the present one, was seriously considered in 1884 and 1885. Messrs. James Brownlee, A. Luders Light and T. Claxton Fidler designed a structure with a clear span of 1,442 ft. The description of that project mentions rock

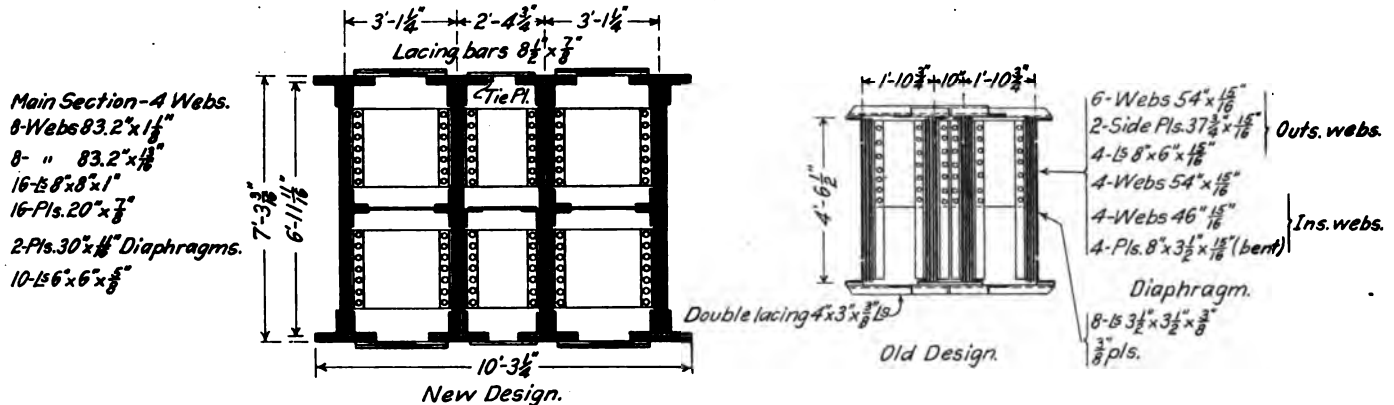

Lower Chords of Old and New Quebec Bridge Designs.

by the borings, while accessible near the shore lines, dips rapidly towards the center of the stream. All these conditions made it imperative to build a span of great length. The information as to bed rock which we now have would indicate that the original project could have been designed with a somewhat shorter span, yet we should remember that this original project was undertaken by a private corporation, and we should perhaps recognize the value to it of such advertisement as the building of

foundations. The more complete information we now have, which was obtained by a costly series of borings, shows that at the present location rock could not have been attained in both piers with any known method of foundation if the piers had been spaced only 1,442 ft. apart, even if the great depth of water could have been overcome.

After the disaster of August 29, 1907, the Dominion government took up the reconstruction of this bridge. A board of

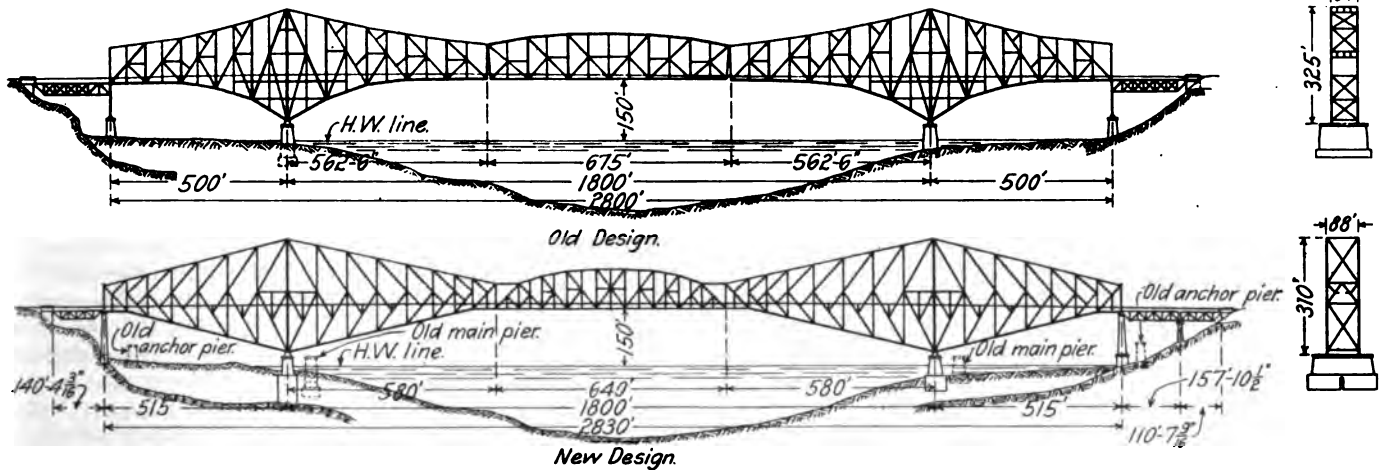

Old and New Quebec Bridge Designs.

the longest span in the world would obviously afford. The next longest span is that of the Firth of Forth bridge, 1,700 ft. It is doubtful if a shorter span than 1,700 ft. would have been practicable at the location adopted for the Quebec bridge. I consider it perfectly legitimate to build a more expensive structure than economy of the work itself would call for, if the more

three engineers, including myself, was appointed to design and construct the bridge. After some study of the situation, the board decided that the new bridge should be made wider between trusses and designed to carry heavier loads than those originally contemplated; that, further, none of the old steel work could be used to advantage. It also decided to keep the same location. The final outcome is a double-truck span of 1,800 ft., with a width of 88 ft. between centers of trusses. The old piers were not large enough for the

\*Abstracted from a paper presented at the meeting of the Mechanical and Engineering Section of the Franklin Institute. Copyrighted by the Franklin Institute.

new design and could not, therefore, be used. The two main piers will be designated as north pier and south pier respectively. At first the board contemplated building an entirely new pier 57 ft. south of the present north pier and enlarging the foundation of the south pier by sinking additional caissons adjacent to the old caisson. The necessary span length would then have been 1,758 ft., and it was on that length of span that tenders were asked. It developed later, from the experience of sinking the north caisson, that the method proposed for enlarging the south foundation would not be safe, even if it were practicable, and so an entirely new foundation and pier were decided on for the south shore. The new north pier could not be placed farther out in the river because of the sloping bed rock and great depth of water. The south pier could not be placed on the north, or river, side of the old south pier, because of the old wreckage, so it was placed 64 ft. 8 in. south of the old pier, or as close as possible to it. Both new piers being placed 64 ft. 8 in. south of the old piers, measured between centers, the new span remains 1,800 ft. long.

With this span length and with the materials now at the disposal of the engineer, the practical limit of cantilever construction has very nearly been reached. In fact, if economy alone is to be considered, a cable suspension bridge would have been cheaper for a span of 1,800 ft. The cantilever structure presents a greater rigidity under moving load, and this greater rigidity was the determining factor in the decision of the board to adhere to the cantilever type. Tentative plans of the suspension type with wire cables were, however, partly worked out by the board in the way of study. The comparative rigidity of the cantilever system and the suspension type may be gaged by the deflections at the center of the span under full load.

New Quebec span, total live load.....	11¾ in.
A cable suspension bridge, trial design—live load only, over.....	2 ft.
A cable suspension bridge—with 120 deg. variation in temperature and full live load—between highest and lowest position about....	7 ft.

The new bridge was finally designed with two anchor arms 515 ft. long, a suspended span 640 ft. long, and two cantilever arms 580 ft. long. The moving loads adopted are two Cooper's Class E-60 engines on each track followed or preceded, or followed and preceded, by a train load of 5,000 lbs. per foot per track. In addition to the actual dead load of the structure, a load of 500 lbs. per lineal foot on the suspended span and 800 lbs. on the balance of the bridge was allowed for snow. The wind loads were taken as follows: A wind load normal to the bridge of 30 lbs. per sq. ft. of the exposed surface of two trusses and 1½ times the elevation of the floor (fixed load), also 30 lbs. per sq. ft. on travelers and falsework during erection; a wind load on the exposed surface of the train of 300 lbs. per lineal foot applied 9 ft. above the base of rail (moving load); a wind load parallel with the bridge of 30 lbs. per sq. ft. acting on one-half the area assumed for normal wind pressure. The assumed wind pressure is equivalent to about 35 per cent. of the uniform live load near the piers and to about 20 per cent. of the live load near the ends of the cantilever arms.

A pressure of 30 lbs., according to German experiments with electric cars, would correspond to a wind of a velocity of over 100 miles per hour. Other experiments made at various times on small surfaces show that a velocity of 85 miles would correspond to a pressure of about 30 lbs.

With a wind of this velocity there would be no traffic on the bridge—empty freight cars or even light passenger cars would be overturned. Velocities of over 85 miles may occur in cyclones and tornadoes over restricted areas. Such storms are very rare in Canada; but even should such an extraordinary disturbance happen, causing a wind pressure of as much as 60 lbs. to be applied to the entire bridge the stresses in the truss members would be less than with the maximum live load and a 30 lb. wind, and although the stresses in the laterals would be increased above the specification limits, they would still remain within the elastic limit of the members.

Where there are no other considerations beyond the actual working stresses in the finished structure, the most economical length of the suspended span for a total span of 1,800 ft. would be in the neighborhood of 1,000 ft. But to erect a simple span of such unprecedented length, either by floating or by the cantilever method, would be impractical. Furthermore, the cantilever method of erecting a suspended span of even a moderate length always requires additional material, both in the cantilever arms and in the suspended span, to take care of the erection stresses. The longer the suspended span in relation to the total main span, the greater will be the required addition—so that whether it be contemplated to erect the suspended span by the cantilever method or by floating into position, the length of the suspended span finds itself limited not by mere economic considerations of the finished bridge, but by either the excess of material required during erection by the cantilever method, and difficulties arising therefrom, or by the difficulties attending the floating of a very long and heavy span into position. These difficulties increase very rapidly with the length of the span to be floated. In the new design the suspended span is the longest which the board considered safe to float, and it fits the entire design very well. The erection of this span by floating made it possible to design it with the view to greatest economy. Its various members will not be subjected to any greater stresses during erection than they would be in a simple span of the same length resting on two piers. It was, therefore, possible to design it as economically as to weight as a well designed simple span would be. It is more important to save weight in a suspended span than in an independent simple span, because each pound in the former requires several pounds in the entire structure to carry it. One pound uniformly distributed over the trusses of the suspended span needs 3 lbs. of metal added to the bridge to carry it, making an addition of 4 lbs. in all. This accounts for curved top chords in the span in question, as well as for the use of nickel steel for the trusses.

It has been pointed out that the length of the anchor arms is uneconomical—that a shorter arm would have been cheaper. It must not be forgotten that a shorter anchor arm increases the pier reactions, as well as the steel in the anchorage proper. The present anchor piers are founded on rock ledges which dip rapidly toward the river. To move them nearer to the river would have involved much more expensive foundations.

It may be remarked here that, while an addition of dead load in the main span will require several times the weight of metal to carry it, an addition of dead load in the anchor arm requires no increase of metal to carry it when there is an upward or negative reaction on the anchor pier. This is explained by the fact that any load placed between the main piers or on the main spans increases all moments and shears over all the spans, while any load placed on the anchor arm, if the reaction on the anchor pier is negative, decreases that reaction and consequently the moments in the anchor arm, but has no effect whatever on the main span. For this reason carbon steel will be used mostly in the anchor arms of the new design. The carbon steel unit stresses adopted are generally 5/7 of the nickel steel stresses, the former requiring heavier members. This additional weight in the anchor arms is a source of economy when the relative prices of carbon and nickel steel are considered.

An opinion has been expressed that the height over the piers is not great enough for economy. Actual calculations show that for economy the height of 310 ft. is too great by about 20 ft. for the "K" system of trussing adopted; further, that this height would have been at least 40 ft. too great for the original system of the official design. The height of the Forth bridge towers, while 26 ft. greater than the Quebec bridge, though the span is 100 ft. shorter, is no doubt economical for the form of trussing adopted. The economical height is not only a function of the length of the span, but also of the panel length next to the pier. This height should be such as to correspond to an in-

clination of the diagonals not far from 45 deg. A double intersection system with very long panels near the pier, such as adopted in the Forth bridge would have been economical for the Quebec bridge, except that it requires a system of secondary members or sub-posts, or very heavy longitudinal girders, or both, to carry the load from panel to panel. Then, too, it is well to reduce in the members the stresses due to their own weight—which in long panels become quite important. The 20-ft. excess in height of the present Quebec design over what would have been the economical height is justified by the resulting reduction in the sections of the bottom chords, which are of considerable size at best.

In long cantilever spans the bottom chords of the cantilever and anchor arms should be straight when possible. With a curved chord the joints must be made at the panel points. These joints are of great importance, as has been shown in the report of the Royal Commission on the Quebec bridge disaster. They should be fully spliced to take care of secondary stresses due to deflections of the span during erection and under the action of live load. It is advisable, therefore, to place them outside of the point of connection with the diagonals and keep them clear of gusset plates. The same objection does not exist in top chords of simple spans, which are of moderate sizes, even in the longest spans known. The economy in simple spans resulting from such curved chords is worth while and quite important, while if any economy were to result from curving the bottom chord of the cantilever and anchor spans, such economy would certainly be of little importance in comparison with the resulting disadvantages. The vertical deflections from live loads are not as great in a straight chord design as in a curved chord design. Another consideration in favor of the straight chords is that the most important, in fact the bulk, of the wind forces travel to the pier through the bottom chords of the cantilever and anchor arms and the wind bracing or lateral system situated in their plane. The straight bottom chords carry these stresses directly to the piers without transmitting any appreciable components to the web system of the trusses. Not so with curved bottom chords. At each joint where the chord's direction is changed a component stress is transmitted to the web. This means that while a pair of straight chords with its lateral system deflects under the action of the wind in the plane of the chords only, a pair of curved chords, by transmitting shear to the web members, causes the trusses to deflect, the windward truss downward, tending to flatten the curve, and the leeward truss upward, tending to make the curve more pronounced. The rigidity of the straight chord design against lateral deflections and oscillations is therefore greater than that of the curved chord design.

One of the reasons why curved bottom chords were used in the cantilever arms of the original Quebec bridge design was the fact that it was the aim of that design to provide full headroom of 150 ft. on a width of 1,000 ft. The bottom chords of the anchor arms were then made curved also for the sake of symmetry. This width on which the full headroom will be obtained has been reduced in the new design to about 760 ft., which certainly is more than ample to accommodate navigation. Only the highest vessels will be limited to this width of 760 ft., and that only at high water.

The top chord of the Quebec bridge cantilever and anchor arms is straight. The Forth bridge cantilever arms have straight top chords also. While there was good reason for making the Forth bridge top chord straight, there was no serious reason, beyond a slight increase in vertical rigidity, for making it straight at Quebec. The two trusses on the Forth bridge are in planes inclined toward each other at the top. The two top chords are parallel. Had they been made curved they could not have been parallel, since they must necessarily be situated in the inclined planes of the trusses. The appearance of tension chords having a greater distance apart at the center of the arm than at either end would have been very bad. But there is no such reason at

Quebec. The trusses are in vertical planes and the top chords could have been curved without serious inconvenience, but also without any advantage. The board considered that, aside from the additional vertical stiffness, a straight chord will present an appearance of strength which a curved chord would not.

With regard to the distance between trusses and their position relative to each other, the trusses of the new Quebec bridge will be in two vertical and parallel planes. The distance, center to center of trusses will be 88 ft. One of the first preliminary sketches made after the board was created contemplated placing the trusses in planes inclined in the same manner as in the Forth bridge, namely, with the tower posts converging toward the top and the bottom chords of both the anchor and the cantilever arms converging toward their respective ends. Another sketch contemplated trusses in vertical planes, but converging for the anchor and cantilever arms toward their respective ends. Both these plans would be economical in the amount of metal required in the finished bridge; but erection of a structure of this magnitude is extremely difficult, and some sacrifice of economy is necessary to make the field work as safe and easy as possible. It was during the erection that the old Quebec bridge collapsed. The board consulted several of the best authorities on erection of large structures, and, while their opinion differed somewhat, it was decided, after much deliberation, to make the trusses parallel throughout. In doing so we had in mind not only the erection which was the principal consideration, but the greater simplicity of details at such important points as the pier posts and the points of suspension of the suspended span. The connections at these points become quite complicated when the anchor arm, cantilever arm, and suspended span trusses are not all in the same plane. It would have been possible to design the bridge with trusses in two planes inclined toward each other, parallel to the axis of the bridge and passing through the end supports of each truss. In this manner all connections of truss members would have been nearly as simple as in the adopted design. Such a design was also suggested and considered. But it was soon decided that the erection of heavy members in an inclined plane of the truss would be too hazardous, and this plan was abandoned. It may fairly be asked, since the Forth bridge, with its curved bottom chords, inclined and flaring trusses, has been so successfully constructed, why was it not possible to follow a similar design in the Quebec bridge? The difference is all in the labor conditions prevailing on the two continents at the respective times of building these bridges. At the Forth bridge 3,200 to 4,100 men were employed when the work was proceeding full swing; their number attained 4,600 for a short period. At Quebec such a large force could not be mustered. The contractors contemplate now using approximately 400 men in the field and not over 1,000, including men in the shops. In the Forth bridge the material was all manufactured at the bridge site. By using a large force of men it was possible to build up the various members of single plates or shapes so that no heavy pieces were handled. The admirable design, consisting principally of tubes, of which there are nearly six miles in the bridge, was built up in a similar manner as boilers are made—piece by piece. The various connections were laid out in the field, plates bent to suit, drilled and riveted on. This method of procedure would be impossible in Quebec. Not only are the men not available, but while on the Forth of Forth the climate is such that work may go on at all seasons of the year, in Quebec work aloft is impossible during more than seven months in the year. Here, then, the bulk of the work must be done by machinery to save manual labor, and must be done in the shops to permit a continuous progress. The work in the field must be reduced to the minimum or to the assembling of large pieces—as large as it is practicable to handle. The American type of pin-connected construction lends itself best to these conditions, but with that type the details will be much simpler and the erection much easier with trusses situated in two vertical and parallel planes.

The system of trussing was from the beginning the object of

discussion and diversity of opinion among the members of the board. The design submitted by the St. Lawrence Bridge Company, with what may be called a "K" system of trussing in the cantilever arms and anchor arms, was finally recommended by the majority of the board and later endorsed by an enlarged board appointed by the Minister of Railways and Canals for the special purpose of selecting the best tender. The main reasons for recommending the design in question are given in the enlarged board's report as follows: (a) The type of design offers greater safety to life and property during erection, as well as economy and rapidity in construction. (b) The design contains the minimum number of secondary members and requires few, if any, temporary members during erection. (c) The system of triangulation, by dividing the web stresses, reduces the members to more practical sections and simplifies the details of connections. (d) The design economizes material, as shown by the calculated weights of the two designs. (e) The general appearance of the structure is, in our opinion, improved. There are two advantages of this "K" design which are not clearly brought out in the above reasons, and on which I wish to lay considerable stress, namely, uniform deflections and regularity of erection operations from panel to panel. Secondary members, or those which receive their maximum stress from partial live load only, such as the vertical suspenders carrying one panel of floor, or members which carry dead load only, such as vertical sub-posts supporting the top chord, or members which normally have no stress in them, such as struts which serve to reduce the unsupported length of main compression members, are the source of local bending in the main members to which they connect. Of the designs submitted, the one adopted has the least number of secondary members. It should be remarked that the same advantage could have been obtained with a double intersection Warren truss by arranging the panel lengths in such a manner as to eliminate the intermediate vertical secondary members supporting the chords.

The regularity of erection operations consists in the fact that, starting from the pier, the position of members in each panel in the "K" design is just like the preceding one, and that coupling up of members in each successive panel, as the traveler moves forward, requires the same succession of motions as in the preceding one, except that pieces become lighter as the erection proceeds. Experience shows that the oftener an erection crew goes through a series of the same motions, as, for instance, in erecting a succession of simple spans all alike, the more rapid their progress becomes.

The lateral wind-bracing has been omitted between the top chords of the cantilever and anchor arms. All wind forces are taken directly to the pier through substantial bracing between the bottom chords. This arrangement not only makes the distribution of wind stresses perfectly definite but permits the spreading of tracks to 32 ft. 6 in., center to center, instead of the usual 13 or 14 ft., which results in a saving in the floor system, and consequently in the entire structure. With the tracks spread, a load on one track only produces a torsion in the cantilevers, and the presence of wind-bracing between the top chords would produce undesirable and excessive stresses which would have to be taken care of by a large addition of metal to the lateral and sway systems and to the trusses.

The floor system is of carbon steel throughout. It is, therefore, stiffer than if made of nickel steel. The long floor beams deflect less and the secondary stresses produced by their deflection are thus reduced. Even then some of the connections of floor beams to posts had to be made by means of pins. The top chords of the cantilever arm and of the anchor arm as now designed are of carbon steel eyebars. The originally submitted design contemplated nickel steel plates riveted throughout for the cantilevers, and carbon steel plates for the anchor arms. By substituting eyebars a better design is obtained and much easier erection assured, and, although nickel steel is replaced by carbon steel in the cantilever arm, the substitution results in a sav-

ing when both the cantilever and anchor arms are considered. Carbon steel will be used in the entire anchor arm, in the top chord and pier members of the cantilever span in the top lateral system of the suspended span, in all the floor system and all sway bracing. Nickel steel will be used in the trusses and bottom laterals of the suspended span, in the trusses except top chords and pier members, and in the lateral system of the cantilever arms. The anchor bars which hold down the ends of the anchor arms have been made very long to reduce bending stresses from expansion.

The suspender eyebars which support the suspended span are subject to oscillation in the plane of the trusses, due to expansion. A total expansion of 16 in. must be taken care of at these two points of suspension—besides the extension of the bottom chords under the live load. Manganese bronze bushings will be provided in these eyebars to permit of easy turning on the pins. But, even should these fail to turn, there is sufficient metal in these eyebars to prevent overstress from bending.

Friction brakes will be installed to prevent excessive longitudinal oscillations of the suspended span under tractive forces of trains.

All latticing of compression members is designed in proportion to the sectional material of each member. The latticing is made strong enough to transmit in transverse shear 2 per cent. of the direct stress of the member.

The bottom chords of the anchor and cantilever arms and their details were the subject of a great deal of study and of many tests. Little is known about bridge compression members when compared to tension eyebars. The Quebec compression chords are members of unusual size. It is only in work of great magnitude that the engineer has an opportunity to make tests on a large scale; the expense of such tests is trifling in comparison with the importance to the structure of the results obtained. It is not sufficient to know that in some bridges a compression member is still standing and is subjected to a certain stress. What we should know is how much greater stress it would take to destroy that member. Such a member may be in the stage of danger from the last straw. The board made a number of tests on models of chords and posts, both for the official design and for the final one. The tests gave generally better results for model members representing the latter. The board feels, therefore, that a good design for these heavy members has been obtained.

There never was any serious doubt among the members of the board as to the advisability of making the bottom chords of the anchor and cantilever arms riveted throughout without pin joints, except at the main pier bearings, to avoid excessive secondary stresses. This was done and will result in a stiffer bridge.

The original design as submitted by the St. Lawrence Bridge Company contemplated top chords built of plates entirely. While this was approved at the time, later studies proved that by building the top chords of carbon steel eyebars there will be a slight saving of weight and cost, and the change was authorized. A tension member built of eyebars is the most reliable type by reason of the large number of full-size eyebar tests which have been and are constantly being made. It is the logical form of construction for transmission of tensile stresses. Their use reduces the secondary stresses. In a chord built up of wide plates with riveted joints, making it continuous, the secondary stresses resulting from bending due to the deflection of the span would be considerable, but owing to the uniform deflection of the "K" design they could easily be taken care of.

*Secondary Stresses.*—I shall not dwell long on this latest addition to bridge calculations. That secondary stresses exist is a fact. They may be from three sources: *First.*—Weight of member. *Second.*—Temperature. *Third.*—Bending from loads.

In the new Quebec design all secondary stresses were calculated and taken care of, but as a result of tests made by the board, the stresses in tension members due to their own weight will be neglected. It is quite possible that if similar tests could

be made for other secondary stresses it would be found that the metal adjusts itself to a large extent in such a manner as to reduce the importance of those secondary stresses and their influence on the elastic limit of the member. Personally, I feel there is a tendency at present to overrate the importance of secondary stresses. They should, of course, be considered in designing a structure; it should be the aim of the designer to reduce these secondary stresses to the minimum, but excessive refinement should be avoided, and unit stresses for direct loads should be made low enough to include these secondary stresses where they may exist.

**FUEL ECONOMY BY THE ENGINE CREW.**

By M. E. WELLS,

Assistant Master Mechanic, Wheeling & Lake Erie, Brewster, Ohio.

During the fall and winter our traveling engineers were furnished with counters so that they could check the number of shovels of coal used by any fireman on any part of the road. Different fireman were checked over the same piece of road and compared. This showed very favorably in some cases; as for example, the three firemen on No. 3. These men all did good work and the amount of coal they used checked to within a few shovels; but cases were found where some men used very much more than others on the same

and the fireman used 327 shovels of coal, while the other engineer made the run in 10 minutes less time and the fireman used but 300 shovels of coal. This was a saving of almost 1/4 ton of coal or about 9 per cent., in other words, 9 shovels of coal were saved in every hundred. If only two shovels of coal in every hundred were saved we could reduce the coal bill on our railroad \$10,000 in one year, and in the United States this would amount to a saving of four million dollars per year.

**HEAVY SLUG FIRING VERSUS LIGHT CAREFUL FIRING.**

Slug firing is the most common of all wasteful practices, and is the hardest to correct. The following trips from Kent to Canton were compared and were otherwise the same except that fireman No. 1 had 98 tons more in his train. No. 1 used 8 shovels of coal to a fire, whereas fireman No. 2 had a lighter train and used from 10 to 20 shovels of coal to a fire. Fireman No. 2 used 254 shovels of coal, while fireman No. 1 used 228 shovels of coal, or about 10 per cent. less than No. 2. We have another comparison where the same fireman made practically similar trips between Adena, Ohio, and Rexford. On the first trip he was allowed to fire according to his regular methods. On the second trip he was coached in lighter and more careful firing with the following result: On trip No. 1 he used 220 shovels of coal, and on Trip No. 2 he used 179 shovels of coal, making a saving of 41 shovels of coal; or about 19 per cent. less than on his first trip.

**OVERLOADING TANKS AT COAL TIPPLES.**

The coal is handled very carefully at Brewster. The hostlers that spill the coal are required to pick it up at once, and it is done. On account of this they spill very little, and do not overload the tanks. This crusade has been carried to the tipples at other points, with good results, but it must be constantly watched and followed up.

If the enginemen and firemen on our road could only know of the poor fuel that is used in some other parts of the United States in locomotives, they would certainly feel that they were very fortunate. On many roads the coal contains so much ash and clinkers that the fireman's work is greatly increased and, in many instances, double what it is with us. The firemen should use every care to have all the available heat units in the coal consumed. The percentage of heat producing material in the average coal on the Wheeling & Lake Erie is shown in the accompanying diagram. It will be seen that 93 per cent. of the coal is available for heat, but not all of it is utilized. There is no more important matter regarding fuel economy than getting locomotive firemen to realize that practically one-half of the heat producing material in our coal is in the form of gas, and that just as soon as the coal strikes the fire these gases are driven off. If this process is not carried on slowly a large percentage of this available heat producing material goes off in gas and is wasted. A locomotive firebox can be made either a furnace for producing heat, or we can make of it, if we wish, a gas retort. If the fire is kept thin and hot so the air can get through it and the fuel is placed in the firebox in small quantities and at reasonable intervals, the gas, as I have described, will be driven off in small quantities and most of it will be burned in the firebox and produce heat as it should. After the gases are driven off there is left on the grates what is known as the fixed carbon of coal (coke) which burns without flame, in an incandescent manner. If, however, heavy charge firing is practiced and 10, 15 or 20 shovels of coal are put in at one time a gas retort is, in fact, made of the firebox. In the first place the fire is very materially cooled by the heavy charge; also much heat is consumed in driving off the gases, the result being that large quantities of gases are driven off at a temperature too low to burn with the oxygen present. In this way a large amount of the available heat producing properties of the coal pass out of the

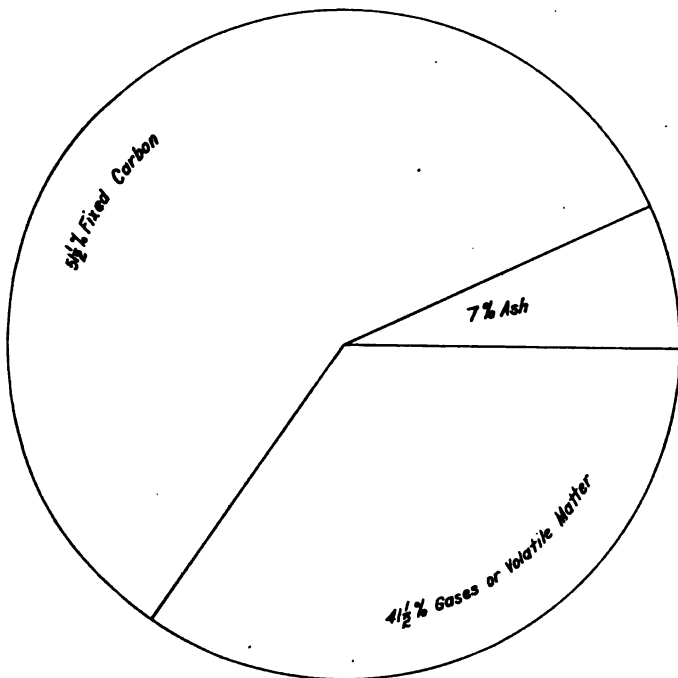

Analysis of Average Ohio Coal Used on the Wheeling & Lake Erie.

run. Some interesting comparisons obtained by means of the counters are given below.

**ECONOMICAL CUT-OFF.**

Under this heading there are two classes of engineers. While the ranks of one of these classes are getting thin, there are a few left. There are engineers who honestly believe in a long cut-off and a light throttle; while the other class, who may truly be called Progressives, believe in a short cut-off and an open throttle, thereby getting greater expansive force out of the steam. An interesting comparison between these two classes of men was shown on train No. 193, between Canton, Ohio, and Kent. There were 1,950 tons in each train and they had the same fireman. There were six days between the two trips and each made two stops. The engineer using the long cut-off made the run in two hours

stack and are lost. Volatile gases burn with a flame and when there is a flame it is assured that the gases are burning. Fixed carbon in the form of coke burns without flame.

If I have made it plain that it is possible to save one, two, three, or even ten shovels of coal out of every hundred now being used, why should it not be done? Why should it not, at least, be tried?

### NEW WESTERN PACIFIC SHOPS AT SACRAMENTO, CAL.

The Western Pacific has had under construction for the past two and one-half years a complete new shop installation at Sacramento, Cal., which was opened for operation July 12 of this year. Eight buildings have been completed and two more are contemplated in the near future.

The office building is 45 ft. wide x 100 ft. long, 2 stories high and is constructed of reinforced concrete. The first and second floors will be occupied as offices while small supplies will be stored in the basement. An annex consisting of a covered platform 45 ft. wide x 50 ft. long and an open platform 55 ft. wide x 150 ft. long will be used for the storage of larger supplies required for repairs to equipment.

A machine and erecting shop 140 ft. wide x 227 ft. long with

which will supply all parts of the yard by gravity. The design and construction of these buildings and tracks has all been handled by forces of the railway company.

### AMERICAN RAILWAY SAFETY ASSOCIATION.

A convention of the American Railway Safety Association, which was organized at Chicago on June 9, was held at the La Salle Hotel, Chicago, on September 22. A. W. Smullen, chairman of the general safety committee of the Chicago, Milwaukee & St. Paul, and temporary president of the association, presided, and twenty-four roads were represented by one or more officers in attendance. The meeting was largely devoted to informal discussions of the various problems encountered by the members in the "safety first" work and to the exchange of ideas and experiences with various methods.

It had been expected to complete the permanent organization of the association at this meeting by the election of permanent officers, but the election was postponed until the next meeting, to be held at the call of the executive committee.

A resolution was adopted endorsing the movement inaugurated by the National Council for Industrial Safety, and a committee was appointed, consisting of M. A. Dow, of the New York Cen-



View of New Western Pacific Shop Buildings at Sacramento, Cal.

two additions, one 20 ft. x 66 ft. and the other 20 ft. x 110 ft., are of steel frame construction with reinforced concrete walls. The building will accommodate 10 engines at one time and is equipped with a 120-ton traveling crane 74 ft. 6 in. long and a 125-ton electric transfer table. Provision has been made for a future extension to this shop of 233 ft. A boiler shop 100 ft. x 140 ft. will be erected opposite the machine shop and will be served by the same transfer table.

A blacksmith shop 80 ft. wide by 138 ft. long, of steel and concrete construction was built north of the machine shop with provision for a future extension of 142 ft. A coach shop 116 ft. by 162 ft., of steel and concrete construction has been erected north of the blacksmith shop, this building being served by 7 tracks. A paint shop of the same dimensions as the coach shop is to be built soon. A power house, 42 ft. x 70 ft., of reinforced concrete construction, with a concrete stack, has been erected directly west of the blacksmith shop. Other buildings include a reinforced concrete electric transformer house, a planing mill, 80 ft. x 140 ft., of timber construction with sheet steel exterior covering and a freight car repair shed, 80 ft. x 160 ft., with open sides and ends and a saw-tooth roof. The shops are equipped with complete water, sewage and fire protection systems, water being pumped from a deep well into a large tank

tral Lines; W. C. Wilson, of the Delaware, Lackawanna & Western; J. N. Guild, of the Union Pacific, and R. C. Richards, of the Chicago & North Western, to attend the meeting of that body at New York during the week, and to report at the next meeting whether or not the Safety Association should join the council and whether it should be recommended that the roads join as individuals.

A communication was read from the Railway Special Agents' Association reporting the result of an interview with Presiding Judge Harry Olson, of the Chicago municipal court, regarding the difficulty in obtaining punishment for trespassers arrested on railway tracks. Judge Olson had issued instructions to the judges that trespassers be fined, but it was learned that the Chicago ordinances against trespassing only applied to elevated tracks. R. C. Richards said he had written letters to the municipal judges, citing statistics as to the evils of trespassing, and A. W. Smullen said he had addressed the judges on the subject at the invitation of Judge Olson. Recently the judges with one exception, have made it a practice to fine or severely reprimand trespassers brought before them. E. M. Switzer, superintendent of safety of the Chicago, Burlington & Quincy, suggested that much good might be accomplished by enlisting the interest of the Boy Scouts organization in the anti-trespassing campaign, and

W. C. Wilson (D. L. & W.) was appointed to confer with the officers of that body.

On motion of C. T. Banks, special representative of the first vice-president of the Northern Pacific, it was decided that each member of the association should furnish all other members with copies of all literature, circulars, etc., used in the safety campaign in order to promote a free interchange of ideas.

There was a long discussion on the question of the advisability of adopting a uniform basis for reporting personal injury accidents. It appeared that the reports of different roads cannot properly be compared at present because of the different bases used. Several speakers were in favor of using the basis required for reports to the Interstate Commerce Commission, which includes as injuries to employees all cases where the men lose three days' time, and as injuries to passengers all cases where passengers claim to be injured. Others preferred to report all cases where one day's time is lost. Several roads have been compiling their reports on that basis for years, and their comparisons would be seriously disturbed by any change. It appeared that in the safety work most of the roads represented keep records of all injuries, no matter how slight, but report in their comparisons only those which cause the loss of one or three days' time, but it was agreed that all roads could readily use the commission basis, as they have the figures compiled for their reports to the commission. A committee was appointed consisting of R. C. Richards, C. & N. W.; C. T. Banks, N. P.; W. C. Wilson, D. L. & W.; C. J. Wymer, C. & W. I., and A. J. Krause, M. K. & T., to report at the next meeting a recommendation as to a uniform basis for reporting accidents.

There was also considerable discussion as to the best ways of using moving pictures in safety work, and of the merits of various propositions made by the film producers to various members.

On the subject of reducing accidents to track men on construction work where a large proportion of the men cannot understand English, and do not remain on the job long enough to be educated, Mr. Banks said that he had accomplished good results by spending a month in the construction camps and working with interpreters to impress upon the men the necessity of greater care. A representative of one large road stated that while among other classes of employees there had been a decrease in accidents there had been an increase among track employees. The road has a large amount of new construction under way and many men in the extra gangs, 17 per cent. of whom change every week, are killed by stepping from behind one train in front of another, or are injured in handling rail.

F. V. Whiting, general claims attorney of the New York Central Lines, said that his company had obtained good results by posting watchmen with megaphones to warn track gangs of approaching trains. E. L. Tinker, safety supervisor of the El Paso & Southwestern, said that a big decrease in accidents to track gangs had followed a series of lantern slide lectures illustrating common causes of accidents in track work.

L. F. Shedd, safety supervisor of the Rock Island Lines, described a campaign to induce shop employees to wear goggles. During a recent period 23 per cent. of the accidents reported on 15 divisions were eye injuries. He had held a large number of noon meetings to talk to the men on the causes of eye injuries, and the company furnished them with goggles. During the fiscal year 1913, the Rock Island had 22 less deaths among employees than in the previous year, and 400 less injuries to track and bridge men.

John Hair (B. & O.) said that his road furnished all shop employees with goggles free, and tried to induce the men not to wear gloves in machine work. It was also stated that the Burlington has furnished all of its shop employees with goggles and has not had a case of a loss of an eye among them for ten months. The Union Pacific has furnished 3,000 pairs of goggles to its employees.

At the close of the meeting those present visited the Safety exhibit car of the New York Central Lines (described in the

*Railway Age Gazette* of August 8, page 229), which was on exhibition at the La Salle street station. Mr. Dow said that 20,000 people had visited the car during its trip from New York to Chicago.

The objects of the association, as described in the constitution adopted at the last meeting, are:

To advance the interests of the safety movement: (1) By affording members an opportunity of conferring and co-operating with each other, and thereby to facilitate the interchange among members of the best and most successful methods for advancing the work of the Safety movement and for realizing its benefits and possibilities. (2) By instilling the idea of safety in the public mind, and by creating a sentiment which will result in the enactment and enforcement of laws prohibiting trespass on the tracks and trains of steam railways, with its consequent loss of life and injuries to persons.

Membership is open to all steam railways of the United States, Canada, Mexico, Central America and Panama, upon the payment of an annual membership fee of \$10. Each road is entitled to one vote. Each road may be represented at all meetings by the officers in charge of the safety organization of such road, and any or all of his assistants, or such other officers or employees as may be designated by the management.

Two regular meetings are to be held each year, upon the second Tuesday in May and November.

L. F. Shedd, safety supervisor of the Rock Island Lines, Chicago, has been elected temporary secretary, and the executive committee is composed of R. C. Richards, chairman central safety committee, Chicago & North Western, chairman; C. J. Wymer, chairman central safety committee, Chicago & Western Indiana; M. A. Dow, general safety agent, New York Central Lines; J. D. M. Hamilton, claim attorney, Atchison, Topeka & Santa Fe; and W. B. Spaulding, general claim attorney, St. Louis & San Francisco. J. Beaumont, signal engineer of the Chicago Great Western, is chairman of the publicity and entertainment committee, and J. W. Coon, assistant general manager of the Baltimore & Ohio, of the membership committee.

### NEW HAVEN OFFICERS' SALUTATORY.\*

On September 2, 1913, Howard Elliott, one of the signers of this statement, arrived in New Haven after thirty-three years' service with the Chicago, Burlington & Quincy and Northern Pacific roads. On the same day J. H. Hustis, the other signer of this statement, arrived after thirty-five years' service with the New York Central and Boston & Albany roads.

We have both come into the management of the New Haven road to work with and alongside of you.

We have no purpose except to maintain, operate, and improve the property so that it may do its work with safety to you and the traveling public, and with efficiency and economy for the shippers and owners.

We hope to make our service for this company our life work.

Today we are all involved in this awful casualty, and the men, as well as the management, and the public, are in great distress over it.

Terrible as it is, we must face it with courage, keep our heads, and do our duty.

We are fellow employees—our duties and responsibilities only varying in degree. Each one of us has a great responsibility to the public, to his fellow employees and to the thousands of owners of securities. We need your help, and we wish to help you. Each must help the other if this railroad is to be run safely.

The work of the great army of employees is most important,

\*This document, which explains itself, was issued by Messrs. Howard Elliott and J. H. Hustis, president and vice-president of the New York, New Haven & Hartford, on September 6, four days after the disastrous collision at North Haven. Being in some respects of unique character it is reprinted here in full.—EDITOR.



because you are engaged in the detailed work of maintaining the road and in operating trains under the rules and regulations laid down by the public authorities and by the management.

Upon the officers there is imposed by law the duty to adopt and enforce every reasonable rule and practice which experience has shown will help to protect life and preserve property. This is a duty that cannot be shirked, and the management must perform it with firmness and without hesitation.

No railroad can obtain safe operation that does not have the earnest and loyal support of its men in all reasonable efforts to protect and perform the service. There is no question of your loyalty. This loyalty can now be shown in no more practical way than by observing the existing rules and by adopting and accepting cordially any further rules and regulations that make for safety.

It is urged that all employees read and re-read the rules in the timetables and in the books governing the operation of stations, trains, yards, signals, shops, tracks, inspection and care of equipment, in fact everything pertaining to operation, and that they confer with one another and with the officers as to the best means of promoting safety.

Take the case of the accident on the morning of September second. The public will discuss, and properly so, improved signals and stronger equipment, both of which are necessary and desirable as a help in preventing or lessening the horrors of an accident of this kind.

This accident should not, however, and would not have occurred had the rules of the railroad been observed strictly, and good judgment, born of experience, been displayed. The men on the colliding trains were all of sufficient intelligence and experience to understand their duties and were of good habits so far as is known. Certainly their appearance indicated that to be the case. It is believed they are men of sincere purpose and high character, as are the great body of men in engine and train service—men who would not intentionally do a wrong and who take a pride in their work. They all had proper rest, or had been given opportunity for taking it, and were familiar with the piece of road over which they were running. The airbrakes and the signals performed their functions. The conditions of that morning had been duplicated many times before, and there was nothing unusual about it, except that a heavy holiday business was being handled. The operating officers of the road, many of them, had been on duty a greater part of the night, in an earnest effort to see that everything was being handled properly, and were relieved to think that Tuesday morning had come without serious trouble, when the news of this awful accident came shortly after seven o'clock.

There is no intention, or desire, at this time, to place the responsibility for the accident anywhere, but certain facts should be made known to all employees at once so that they may take additional steps to protect themselves, their fellow employees, and the public.

The accident happened within what is known as automatic signal territory. The various rules require a number of specific things:

1. When an engine nears one of these signals set at danger it should stop *before passing the signal* and then proceed.
2. The duties of trainmen and flagmen in the matter of protecting trains, are clearly set out.
3. The responsibility of the conductor for checking up his flagman is also made clear.
4. The duties and responsibility of the engineer are set forth clearly.

It is true that rules cannot be made to cover every contingency, and much must depend upon the intelligence and interest displayed by the particular individual in applying the rules.

There is not, nor can there be, any other duty so important as the protection of a train loaded with human beings.

This piece of road where the accident occurred has been

operated safely for many years under the same conditions that existed the morning of September second. It is true there was a fog, but that is a condition to be met at certain seasons of the year in places along the sea coast and on many railroads, and in such cases there should be, of course, unusual care and caution exercised.

It is also true that the signal system now protecting the track where the accident happened is being replaced, so that under similar conditions the engineers of both trains would have received a warning signal a mile or more in advance had the home signal shown danger, but the protection of signals, under no circumstances, can relieve the train crews from the duty and responsibility of prompt and accurate flagging.

The flag, fusee and torpedo should be used as if there were no signal system. Every extraordinary stop may be but a short distance from a following train, and the flagman should act quickly at all times, as if the danger were great and his time limited.

While the question of physical condition and ability of the men involved does not enter into this accident, yet as a result of accidents that have occurred, there are certain rules and practices which it is proposed to introduce into the service solely with the idea of increasing safety and operation for the protection of the public and of the employees.

These rules refer to examinations for vision, color sense, hearing, and, under certain conditions, other physical tests. The proposed rules are similar to those that are being used on other standard lines in this eastern territory.

We believe you will agree that this is too serious a matter, not only in the interest of the public, but of yourselves and your families, to be delayed.

Nothing unusual will be required, or expected, and no unnecessary hardships will be entailed, for the railroad needs the experience that comes from years of service, and wants to retain every good man in the service, who is physically competent to perform the duties.

We desire to work with and through those officers of the company who are charged directly with the supervision of the operating department—A. R. Whaley, vice-president; C. L. Bardo, general manager, and the general superintendent, mechanical superintendent, division superintendents, trainmasters and master mechanics, and other operating officers, many of whom come in daily contact with you and who have the same spirit and desire that we believe you have—namely, to do their full duty to those with whom they work, their fellow employees, the patrons of the road, and the owners of its securities.

The New Haven road is a great property, and there is no reason why, with loyal support and hearty co-operation of all, it should not be made the best and safest road in the United States.

Let every man in the service resolve that from this time forth he will redouble his efforts to do his duty, that he will not speak disrespectfully of the road, of his fellow employees, or of the management—that he will welcome just criticism of the service, and do his part to apply remedies that will prevent such criticism, and let all ask the public to aid them in their efforts to disparage unfair and unjust criticism, so that the undivided attention of all employees and men can be in accord with the important work of trying to serve the public with absolute safety.

**DIVIDENDS AND CAPITALIZATION OF RAILWAYS IN THE UNITED KINGDOM.**—The average rates of dividend paid by the railways of the United Kingdom on the common stock fell from 3.62 per cent. in 1911 to 3.45 per cent. in 1912, and that paid on the preferred stock fell from 3.56 per cent. in 1911 to 3.52 per cent. in 1912. The rates on the other classes of capital remained practically unchanged. The authorized capital of the railways amounted at the close of 1912 to \$6,864,198,250, an increase of \$45,015,125 as compared with 1911. At the close of 1912 the total amount of capital returned as paid up was \$6,496,777,500.

# CONGRESS OF REFRIGERATION.

Important Papers Were Presented at the Railway and Steamship Section, Including a Consideration of Pre-Cooling.

The third International Congress of Refrigeration was held at the Hotel LaSalle, Chicago, September 17 to 24. Previous sessions of the congress were held in Paris in 1908, and in Vienna in 1910. A formal opening session was held at Washington, D. C., on September 15, after which the delegates went to Chicago in special trains via the Pennsylvania. The congress at Chicago was divided into six sections which held sessions daily. These were (1) liquefied gases and units; (2), refrigeration machinery and insulating materials; (3), application of refrigeration to food; (4), industrial refrigeration; (5), railroad and steamship refrigeration; (6), legislation.

The meeting of the section on railroad and steamship refrigeration was called to order on Wednesday, September 17, by Vice-president C. M. Secrist, in the absence of the president, W. C. Brown. The following honorary presidents were announced: Juan Carlos Gallegos, Argentine Republic; Robert Dussich, Austria; Pellerin de Latouche, France; R. Habermann, Germany, and D. N. Golovnine, Russia. The welcoming remarks of Vice-president Secrist were responded to by Pellerin de Latouche, honorary president.

A paper was presented by J. S. Leeds, manager of the Santa Fe Refrigerator Despatch, on "Organization of Transit Refrigeration," in which the author urged the great need of a comprehensive and essentially distinct department for the supervision of protected service offered to perishable goods in transit. At the conclusion of his paper Mr. Leeds presented the following resolutions:

"It is moved: That the congress approve in principle and so far as practicable, that:

"(a) The protective service such as refrigeration, afforded to perishable goods in large volume, justifies and requires a separate organization or department sufficiently comprehensive to cover all features of that service and attain the highest efficiency.

"(b) In general, the service of refrigerating in transit should be segregated from the service of transportation proper and should be treated as a separate item of expense rather than to be included in the regular transportation rate.

"(c) The service of refrigeration in transit should be charged for on basis of distance or of fixed charges between specified zones rather than on basis of actual weight of ice furnished.

"(d) Consignees of fruits and vegetables and other perishable goods who neglect or refuse to unload insulated cars promptly, should be assessed for such detention a reasonable charge in addition to other customary charges on non-perishable goods in ordinary care."

The meeting on Thursday was called to order by Vice-president C. M. Secrist, who surrendered the chair to the Honorary President M. Pellerin de Latouche, who presided over the session during the presentation of the following papers: Richard Bloch, chief engineer, Orleans Railway, France, Necessity of a Uniform Regulation to Facilitate the Movement of Refrigerator Cars. Richard Bloch, Co-ordination of Efforts Between the Great Navigation Companies and Railways for Refrigerator Transportation. Richard Bloch, Laws and Regulations Relative to the Transportation of Perishable Goods. A. Charron, assistant chief of traffic, French South Railway, Practical Means of Interchanging Refrigerator Cars on Tracks of Different Gage. Maurice Roux, The Progress of Refrigerator Transportation by Water in France.

The first two papers by Richard Bloch were discussed at some length. Remarks were made by Mr. Monteil on means of cooling water in refrigerator cars, concerning which subject a complete paper had been prepared for presentation in full at another section.

Remarks were also made by C. M. Secrist, vice-president Pacific Fruit Express, regarding the importance to American producers, as to the efforts being made at European ports between the steamship lines and the railways to provide continuous refrigeration in transit. Pellerin de Latouche responded to Mr. Secrist's remarks, expressing appreciation of the progress made in refrigeration transportation by American companies, while at the same time predicting that American goods would meet with some competition in the way of perishable goods produced in Europe.

At the remainder of the session Vice-president C. M. Secrist presided, and the following additional papers were read: Macklaier, Method of Protecting Perishable Freight from Loss and Damage by Freezing Weather; and the Use of the Recording Thermometer. A. M. Mortensen, manager transportation service, Panama International Exhibition, Relative Consideration of the Need of a Comprehensive Organization by Transportation Companies. G. C. Bohn, White Enamel Refrigerator Company, Consideration of the Means at Present Employed in Railway Cars for Effecting Refrigeration of Perishable Goods Therein.

The section was called to order on Saturday by Vice-President C. M. Secrist, and the following papers were presented:

Prof. D. N. Golovnine, Moscow—Transportation of Perishable Freight on the Russian Railways; C. M. Secrist, Pacific Fruit Express—Methods of Pre-Cooling Perishable Goods at Loading Points; C. M. Secrist—Initial Icing of Refrigerator Cars by Railroads; C. M. Secrist—Facilities Maintained by Railroads for Replenishing Ice for Refrigeration in Transit; H. M. Wigney, car service agent, Pacific Fruit Express—Consideration of the Necessity of Uniform Regulations to Facilitate and Control the Circulation of Refrigerator Cars in Interstate Commerce, Including Their Possible Transfer in the Loaded State to Boats Over Rivers and Other Bodies of Water; C. J. Beck, freight traffic manager, Hamburg-American Line—Refrigeration on Ocean Steamships; Pedro Berges—Frigorific Transportation by Water; Its History and Development from 1867 to 1913, Especially from the Point of View of the Transportation of Frozen and Refrigerated Meats from the Argentine Republic. The author presented the following draft of conclusions for consideration and possible adoption: The Third International Congress of Refrigeration in Chicago recommends that the governments of the countries adhering to the Congress and interested in this question who have not yet done so should establish an official control of sea transportation of refrigerated foods in order to avoid the loss in reputation to which people engaged in this transport are now subject, and in order to reduce the prices of refrigerated and cold storage meats. They should develop and increase the installation of cold storage houses in the ports of export and import and in the centers of consumption, as well as that they should increase the means of cold storage land transportation.

He recommended to the International Association of Refrigeration that this question of maritime transportation should be included in the program of the next International Congress to take place under its auspices, in addition to the resolutions adopted at the Congress of Vienna, concerning the unification of the methods of inspecting cold storage meats.

At the session on Monday the following papers were presented: Peter Neff, consulting refrigeration engineer—Theory and Practice of Using Ice in Transit to Prevent Freezing of Perishable Goods; Emile Druart—Mechanical Traction of Merchandise and the Use of Trucks on Tramway Tracks for Running Refrigerator Cars over Tracks of Different Gage; W. E. Sharp—The Advantages of a Combination Heater and Refrigerator Car; R.

H. Parks—Dimensions, Proportions, Capacity and Insulation of Refrigerator Cars; Walter B. Pollock, manager marine department New York Central Lines—Transportation of Perishable Goods by Barges; B. W. Redfearn, president Frisco Refrigerator Line—Methods of Pre-Cooling Perishable Goods; H. B. Wood, Gifford Wood Company—Handling Manufactured Ice at Icing Stations.

On Monday afternoon a meeting of the American Association of Refrigeration was held, to which all members of the Congress were invited. On Wednesday the National Poultry, Butter and Egg Association and the American Railway Perishable Freight Association held a joint session with the section on Application of Refrigeration to Food. On Tuesday evening the Congress had a banquet at which all of the edibles were cold storage products, many of them having been shipped under refrigeration from all parts of the world.

The following are abstracts of some of the more important papers which were presented at the railway session:

#### FACILITIES FOR REPLENISHING ICE FOR REFRIGERATION IN TRANSIT.

By C. M. SECRIST,

Vice-President and General Manager, Pacific Fruit Express Company.

Re-icing stations, as maintained by railroads, can be divided into two classes, the first being plants that are owned and operated exclusively by the railroad, or, by a car line with which the railroad has contracted to handle its perishable business insofar as the furnishing of equipment and refrigeration is concerned; second, plants that are owned and operated by outside concerns under contract with the railroad to furnish ice put into tanks of cars under railroad supervision at a stated price per ton.

In order to minimize loss resulting from the meltage of ice while held in storerooms at these plants, it is now customary in the construction of plants to thoroughly insulate them, particular attention being given to the insulation of the floor and of the ceiling of the storerooms, as well as the sides and ends, and the old practice of using sawdust, hay or other preservatives to prevent the meltage of ice is rapidly being abandoned for the former method, as it has been demonstrated that notwithstanding climatic conditions or cheap original cost of ice, proper insulation of storage rooms fully justifies the additional cost of such construction by the saving made in the meltage of ice.

In order to minimize delays to cars in transit, which require re-icing, and also as a matter of economy in operating the plant, an elevated platform, slightly higher than the top of the car, is built alongside the plant, sufficient to accommodate the business to be handled. These platforms are usually long enough to accommodate from ten to twenty cars at a time, and, it is needless to say, are so located and served by tracks that they will permit cars being placed for re-icing without unnecessary switching. An ideal arrangement is to have the icing platform so located that main line trains can pull by them without any switching.

As a further measure of prompt handling and economy, these platforms are equipped with endless chain conveyors, running their entire length, and the ice is handled out of the house to the platform by elevators. By the use of such modern facilities, a record has been made in some parts of the country of re-icing an entire train load of refrigerator cars with a total detention averaging one minute to a car.

Elevators and carriers mentioned above are usually operated by either gasolene or electric power, the latter being much preferable when practicable as a minimizing danger from fire.

A proper record of all cars re-iced at these stations is kept by a railroad or car line representative, this record including time of arrival and departure, and condition of the ice tanks, that is, quantity of ice in each tank when received and the amount of ice supplied at the station, and which record is sub-

mitted to the proper officer of the company for further handling.

It is customary at these stations to have the drain pipes leading from the ice tanks of cars examined to see that they are open and flowing freely, which is also included in above record and report.

Perhaps mention should be made of the method of handling ice from the platform into the cars, which is done by the use of short skids reaching from the platform to hatch openings in the ice tanks. Employees soon become very expert in handling ice this way, reducing the time consumed to a minimum.

#### METHODS OF PRE-COOLING PERISHABLE GOODS AT LOADING STATIONS.

By B. W. REDFEARN,

General Perishable Freight Agent, Frisco Lines.

Pre-cooling is unquestionably a forerunner of greater developments in the producing and distributing of perishable freight, as that seems to be its greatest sphere of usefulness. It is proving a material factor in developing production in places that were until recently waste and barren, a supplier of pure and wholesome fruit to the growing consuming centers far removed from a producing territory; and in no small way contributing to the increasing standard of living in the United States.

Pre-cooling is but better refrigeration methods in that it obtains a very desirable condition of low temperature in fruits and vegetables within a very short time after they have been taken from their natural state.

It is safe to say that almost as soon as fruit is picked and removed from its natural state it begins deteriorating unless arrested by bringing it to a low temperature, where it will remain in practically the same condition for a considerable time, varying, of course, with the degree of temperature and nature of the product. It has, therefore, been apparent for some time that in order to obtain the best results, the sooner fruit and vegetables were reduced to that temperature of arrested decay, the more successfully they might be preserved and transported.

For years previous to any work along this line with fruit, the great beef packing industries had been compelled to thoroughly chill and often freeze meat before loading in refrigerator cars for transportation. They also early recognized the necessity of thoroughly cooling the cars before loading. With the temperature of the interior of the refrigerator reduced to as near 32 deg. Fahrenheit (0° C.) as possible or lower, the meat reduced to a lower temperature, it enabled them to ship for long distances, en route several days, and it is but natural that small local slaughter houses should be superseded by the large centrally located and well equipped plants where the work is done more efficiently and economically. With but minor changes, the same method was the first used in the pre-cooling of fruit.

However, the successful transportation and distribution was not the only agency that brought it about.

California is by nature fitted to produce great volumes of the most excellent quality of fruits and vegetables in an almost continuous cycle, from the beginning to the end of the year. The volume of production rapidly outgrew both the facilities of the carriers, or railroads, to transport and the ability of the markets to consume. This condition made it necessary for the growers of citrus fruit to erect refrigerated warehouses, to hold their product against a car shortage or a glutted market, and it was early found that thoroughly cooling the fruit before loading in the cars for transportation had a decided beneficial effect on the carrying qualities. It is but natural that the warehouses should then be utilized to assist in the transportation by pre-cooling.

These refrigerated warehouses are insulated warerooms, served by the usual refrigerating machinery of which there are many types, founded on the same general principle, with some special equipment for quickly and economically handling the boxed fruit.

Such warerooms are, and have been, provided by many of the large poultry and egg producers at the large shipping centers and serve the same useful purpose in handling that important product.

It is clear that warehouse pre-cooling calls for a big expenditure and can never be more than a local proposition at exceptionally large producing points. The producers at the smaller points could neither build on account of the capital required nor take advantage by trans-shipping to a warehouse for pre-cooling. For the hosts of small producers at numerous shipping points, the pre-cooling of fruit after loading in the car at some central point was the only solution of the difficulty and it was obvious that the service must be rendered with co-operation of the carriers or by them.

With very few exceptions, fruit transported by the railroads moves under two separate charges; one charge is for transportation alone; the other to cover the heavy expense of furnishing ice and icing service to the cars en route. This latter expense paid by the shippers or receivers, is in addition to the ordinary freight charges, and is a fixed amount from each shipping point to each destination, the carrier furnishing all ice for initial icing or pre-cooling of car and subsequent re-icing.

It developed that if citrus fruit was thoroughly pre-cooled and loaded in a cold car, the initial icing was sufficient to convey it safely to destination even when the journey consumed eight or ten days in transit without re-icing. This naturally caused the shippers to think that inasmuch as pre-cooling was a factor in reducing the cost of refrigeration in transit to the carriers, they should reap some of the benefits of this saving in a reduced refrigeration charge. The carriers on the other hand were enjoying a reasonable profit on this refrigeration service and in order to protect this source of profit and the big investments, they had, at intermediate stations en route, built plants and offered pre-cooling service after loading of fruit in the cars.

This dispute led to a long drawn out legal controversy between the combined growers on one hand and the carriers or transportation companies on the other, which will doubtless be disposed of in the near future. It is regrettable that this condition prevailed, as it retarded the development of this industry in the field where it would have had the best opportunity for experimental work.

Car pre-cooling is, in a word, simply treating each refrigerator car and its contents as one of numerous separate units or cold storage rooms connected with a central refrigeration producing plant by flexible cold air conduits.

There are two distinct systems that have been extensively developed and used, each with its good merits and ardent supporters. One system known as the "Gay System" and the other as "Intermittent Vacuum Pre-cooling."

The first named might be termed a continuous direct draft of cold air with forced circulation between the packages and contents of the car. The second, an intermittent system of draft of cold air forced into the car by fans causing as high pressure as the loose construction of car will permit, followed intermittently by a period of pumping out and tendency to produce partial vacuum.

It is a well known fact that all fruits and vegetables contain when harvested an amount of latent heat or gases; this latent heat, or gases, is nature's aid in ripening the fruit or vegetables as the case may be. After the article is harvested, in order to prevent deterioration these gases should be removed. This is accomplished by the methods of the intermittent vacuum pre-cooling process.

The equipment of the plant is in a general way the equipment of any modern ice and cold storage plant, and nearly all of the plants of this system are equipped to manufacture ice when not actively pre-cooling cars.

It requires a very large volume of cold air that is obtained by the ammonia pipes placed in two insulated rooms where the air is rapidly cooled to the desired temperature. This cold

air has a forced circulation from a large powerful fan. It is forced through a valve into fixed cold air ducts. It can then be shunted by use of other valves into flexible cold air ducts into the cars to be pre-cooled. These cold air ducts are fastened to the car by a false door that fits tightly into the door frame of the cars. Outlet ducts leading back to the cold air rooms are attached in a similar way to the ice bunker hatches in the roof of car. The intermittent vacuum process then proceeds for a few minutes; the large fan is used as a vacuum pump and draws out the warm air and gases, and causes a circulation even in the center of the fruit packages. This pumping out of air is discontinued by changing the large valves, and automatically the fan in the cooling rooms begins to force cold air by high pressure into the car and on account of the partial vacuum previously created, permeates the very center of all the packages. This system can therefore claim to give two very useful results—one withdrawing the impure gas and air, second creating a strong forced circulation, accomplishing quick cooling—the latter very much to be desired.

The future of pre-cooling fruits, vegetables and meat products is assured. It is a prime necessity in the proper distribution of our food products and, in my opinion, one of the two movements for lasting good in the agricultural world today, and provides a better method of distribution and a larger area for marketing.

#### ORGANIZATION FOR HANDLING REFRIGERATION TRANSPORTATION.

By J. S. LEEDS,

Manager, Santa Fe Refrigerator Despatch Company.

A complete and dependable organization is necessary to successfully transport perishable commodities to markets in a country as extended as the United States and Canada, embracing an expanse from the Atlantic to the Pacific ocean, and from the gulf of Mexico to Canada, inclusive. The production embraces all of the fruits and vegetables grown in the temperate zone, and movement embraces all of the months of the year. The growth in the consumption of fresh fruits and vegetables has reached such proportions that it is now a necessity to place on the tables of all of the people at all seasons of the year the product of any part of the United States, Canada and Mexico, the movement being almost wholly by railroad transportation and interchangeable according to the season and the point of production.

In order that this may be successfully accomplished, the goods must be placed in the hands of the consumer in a wholesome and sanitary condition, in a state of perfection as to maturity or ripeness, and undeteriorated. Long distances covering hundreds or even thousands of miles are embraced in the movement from the producer to the consumer. Protection against weather or climatic conditions embracing wide ranges of temperature must be overcome.

The cars for the purpose must be suitable vehicles specially constructed and strong enough to withstand the transportation in heavy trains over heavy grades, with safety to the property they carry. They must be assembled within the district of production, cleaned and put in perfect sanitary and physical condition for use, and supplied in sufficient numbers to promptly meet all demands. These requirements must be estimated and anticipated in advance of the orders of shippers for cars so that the equipment may be available when wanted. This requirement is especially true with respect to large blocks of perishable commodities to be moved over long distances and embracing a wide distribution to numerous markets. A failure to meet promptly the demands with the necessary equipment involves the carriers in a serious liability for damages to the extent of the value of the property tendered for shipment. To supply the necessary equipment involves the assembling and movement of large numbers of empty cars frequently in full trains and on expedited time.

To market a single crop, such as berries, peaches and other deciduous fruits, covers a period of forty to sixty days. In such

cases a single car can make no more than one or two trips on a single crop. Unless a carrier has a succession of crops of perishable freight, other service for the equipment must be planned and secured, and the cars moved to each succeeding field of operation.

California produces a large variety of crops and covers in the marketing the whole country embraced in the United States and Canada, and embraces the whole year, fluctuating widely as to volume at different periods, ranging from a few carloads to 300 or 400 cars per day. The movement of a car normally for a round trip in marketing a single carload of that product will average approximately eighty days. During the year all other crops, composed of berries, peaches, pears, cantaloupes and summer vegetables are provided for in their season.

Along with the car supply must be provided an adequate quantity of ice to meet requirements at stations where needed. Much of the fruit and vegetables require pre-iced cars to insure the safe transportation of the commodity. Such cars are iced at the icing station most convenient to the shipping station. They are distributed and placed at the loading stations and when loaded are replenished to the full capacity of the ice bunkers at the first icing station in transit, generally at the point where car was initially iced, after which the re-icing is accomplished at suitable intervals at regular icing stations, approximately once each twenty-four hours, the intent being to keep the bunkers as well filled as possible; and while there is no established danger point as to the quantity of ice to maintain, the rule generally observed is that bunkers shall not sink below half full while the car is in transit. A good rule for good work is that ice ought not go below the level of the top of the load in the car.

The ice supply is as imperative and the requirement at the hand of the carrier as pressing as is the supply of cars to cover the demands in the prompt movement of the crop. These two demands upon the carrier are as urgent and must be provided for as promptly as a payment at the bank when an obligation is due.

In order to do this, icing stations are maintained at intervals of twenty-four to thirty hours apart. Carriers must be prepared to meet all of the contingencies that come up, such as detentions from washouts, derailments, blockades, so that they can properly protect the property. A code of rules is in force covering the case as fully as possible in such way that property is protected and the service is applied without reference to anyone for further authority. The rules are automatically and continuously in effect; the necessary supervisory force is constantly on duty and the labor and accessories are at hand to meet the demands of the service. For this purpose inspectors are maintained to insure that proper icing is performed; also to make and preserve in permanent file the service record for reference at any future time when it may be needed.

As an adjunct of refrigeration, pre-cooling applied to loaded cars has been in operation for a period of two or three years. Three pre-cooling plants of large capacity in California and one plant in Texas have been in operation, and the results obtained have been successful and satisfactory to all parties interested. In addition to the above, small plants of various types have been operated at many points, mainly by individual shippers, and with varying results. This work has been more or less experimental.

Pre-cooling is no doubt destined to become an important factor in transportation refrigeration, especially in the case of the more tender deciduous fruits which are obviously more susceptible to successful treatment and with larger benefit to shippers than the less perishable citrus fruits.

The telegraphic "consists" of trains carrying cars of perishable freight under ice are sent to headquarters of the line, and reports of passing the principal district terminals or junctions are transmitted and consignees at destination or terminals are advised of the progress of their cars, thus enabling them to place the goods on the market or file orders for diversions to the markets in which they may desire to place the commodities. Cars at destination are properly iced and cared for until disposed of with-

out previous or additional orders to do so. All of the accessorial transportation service is assumed and performed as provided for in the legally issued tariffs of the carriers. These tariffs are issued jointly, or are concurred in, and through billing accompanies the cars. Thorough icing arrangements are in effect, the initial carrier originating the instructions to cover from point of origin to final destination, including all icing or expense in such way as to have the total assessed against the property upon final delivery. In order to expedite the movement, an accepted bond of indemnity is in many cases executed, covering all reasonable contingencies. The carriers of a large proportion of perishable freight undertake to supply the refrigeration to all destinations at a fixed price (more or less according to the point of destination), and all expense for icing in transit is collected from the initial carrier, so that the shipper knows at the point of origin what the refrigeration expense will be upon delivery of the goods to the consignee at destination. In this way the shipper knows at the start the quality of service he may depend upon and what the expense will be from point of origin to any market large enough to consume or dispose of a carload of product anywhere in the United States or Canada.

A system of daily reports is rendered from all of the principal icing stations and from all junction points of the originating line with other roads, noting the date and hour of arrival and departure of cars, quantity of ice in the ice bunkers on arrival and departure, and the outside temperature.

The rules governing the conduct of the traffic in transit are made as arbitrary as possible so that nothing which can be covered in the instructions on the waybill is left to the judgment of employees, who may be more or less inexperienced in the requirements.

As much advance information as possible concerning the number of cars to be iced is forwarded, either by wire or by passenger train, ahead of the freight train in which cars are moving, to icing and inspection points, in order that the necessary ice may be on the platform, and the employees ready for service upon arrival of the cars to be iced, thus obviating unnecessary detention.

All of the principal routes in the United States and Canada are equipped with facilities for supplying ice and the re-icing of cars to such an extent that icing and refrigeration tariffs, when published, are made for state-wide application by all originating carriers, and in such a way that a dependable supply of ice is always at hand to meet all requirements. Such points are designated as regular icing stations, and the information is published in circulars which are placed in the hands of agents at originating points, and are available to shippers. In addition to this, there are numerous auxiliary icing stations at which a supply may be had in cases of detention or emergency. The standard rules of universal application provide that in cases of detention at points other than regular or auxiliary icing stations, a supply must be obtained from any available source, either at the station or by train from some adjacent point, the idea conveyed being that the property must be protected. The general plan is now so extended that it is a remote probability that a car of perishable freight may pass from point of origin to market without complete refrigeration protection. Some conception of the wide scope and the completeness of the organization required may be had when the fact is realized that much of the business moves over long distances, covering two or more roads, the distances ranging from the limit of one state to the length and breadth of the United States and Canada. The range of commodity is as varied as the distances covered.

The organization for handling the business has been developed as the necessities of the business have demanded, and has not been worked out by any well defined and predigested plan. It is largely the result of individual effort, as the requirements for service in reaching the more remote markets with a rapidly increasing volume of production have developed, and from a rapidly developing demand for the commodities in districts where the commodity is not in season or where it is not produced at all.

Much of the operation is crude and more or less cumbersome, resulting in some lack of economy in the conservation of the revenue of the carriers. The competition between carriers and the requirements of the business has resulted in carrying out the theory of perfection of service which obviously is necessary in the transportation of highly perishable commodities and without much regard to economy in the expense of doing it.

The wide distribution of perishable food commodities throughout the whole country has developed rapidly and to some extent in advance of actual demand, much of the product seeking the market, instead of the market seeking a supply. The carriers, and incidentally the refrigerator lines, have individually and collectively taken an active part in projecting the trade to the utmost extent possible. The details of the service have been brought to a high state of perfection. Tariffs and rules governing it have been prepared and published, and a great deal of attention given to uniformity of practice.

These things have been accomplished very largely up to the present time by individual efforts of carriers, producers, and shippers representing certain districts and zones of production, and have had the effect of stimulating production. Improvement in marketing facilities has produced a more universal demand for such products. The distribution area is constantly widening and extending. The discrimination on the part of consumers as to quality and condition is growing closer each succeeding season. This demands more perfect service, taxing to the utmost the ingenuity of all parties who are engaged in handling the products (especially the transportation) to devise ways and means of performing the service in an acceptable manner. The supplying of the markets covers every hamlet in the whole country which can be reached with transportation facilities by steam or electric roads or by water carriers. This at least suggests, if it does not require, an organization which comprehends the whole country embraced within the limits of the transportation system of the United States, Canada and Mexico, in order to accomplish the things necessary to be done. This must embrace all of the accessorial service which must be anticipated and ready for use at all times and at available points, and must be uniformly the same to all shippers.

The organization of this highly specialized service for perishable products is a trade within itself, separate and distinct from other branches of transportation. The movement of commodities must be accomplished without detention between the point of origin and point of consumption, generally in the same car in which the goods were originally loaded. Usually a large number of changes of destination are allowed in order to avoid overstocked or glutted markets. These changes are accomplished with a minimum of detention, in many cases without any delay, where orders for the change are placed in advance of the arrival of cars at first way-billed destination. Barring extraordinary circumstances, such as derailments, floods, or other unavoidable causes, the cars move with regularity so that shippers may calculate with reasonable certainty when they will reach the destination for which they are intended. Taking into account the inherent nature of the fruit or vegetables, a very close calculation may also be made as to their condition on reaching market. Loss and damage on account of improper or insufficient refrigeration in transit on properly handled products before and during transit is rapidly being reduced to a minimum.

The foregoing is an ideal way to conduct the transportation and handling of perishable products, and is in practice on individual roads handling large blocks of business. It is what a comprehensive organization covering all of the producing districts should be able to promise to the producers and shippers of all of that class of traffic where the movement is regular and sufficient to justify it.

Some of the features which a comprehensive organization would necessarily embrace are indicated as follows:

*First*—They should be authorized to prepare or compile and publish suitable rules governing as uniformly as possible, all phases of the service to be performed by the carriers.

*Second*—(a) To prepare by suitable committees, and publish local and joint icing and refrigeration charges. (b) All accessorial service rules and charges, including heated car service in cold weather and detention charges as may be found necessary to expedite the disposition of commodities and secure the prompt release of cars and their return to service.

*Third*—To so promulgate rules, rates and regulations as to enable agents, producers and shippers to obtain definite information as to rates and service to markets which the shippers may desire to reach.

*Fourth*—To promote the performance of everything pertaining to the handling of perishable products required by law to be performed by the carriers.

*Fifth*—To co-operate with shippers in the comprehensive and equitable distribution of perishable products to all markets, to the end that demands may at all times be fully supplied as far as may lawfully be done by the carriers.

*Sixth*—To promote and preserve equitable relations between shippers and carriers in all phases of the service in the handling and care of perishable freight, including legal obligations and liability under the law.

*Seventh*—To aid in the study and disposition of special matters by procuring and compiling authentic information, and the dissemination thereof, relating to perishable products.

An organization to properly conduct the business must necessarily cover all phases of the service, which will embrace refrigeration, ventilation, heated car service, and such initial and terminal service as will enable producers and shippers to proceed with confidence that their business will be properly safeguarded and that nothing will be left undone for the proper and safe conduct of the business which may logically be the duty of the transportation interests to perform.

## LARGE PASSENGER LOCOMOTIVES FOR THE C. & O.

The Chesapeake & Ohio has recently received from the Baldwin Locomotive Works, eight Pacific type locomotives which are of special interest because of their capacity, design, and the difficult service conditions under which they are to operate. They will be used on the Allegheny district of the Hinton division, between Clifton Forge and Hinton, W. Va.\* The ruling grade, eastbound, is 30 ft. to the mile for a distance of 16 miles; while westbound it is 60 ft. to the mile for a distance of 13½ miles. The new locomotives are designed to haul a train of ten cars, weighing 692 tons, over the division without assistance, maintaining an average speed of 24 miles an hour over the 60-ft. grade. Heretofore, when using Pacific type locomotives, it has been necessary to double-head trains of this weight.

The new engines have a tractive effort of 44,000 lbs., and with 179,900 lbs. on drivers, the ratio of adhesion is 4.08. The equivalent total heating surface, making the usual allowance for the superheater, is 5,105 sq. ft., or 276 sq. ft. per cubic foot of cylinder volume. These ratios indicate that the weight on driving wheels, is fully utilized for tractive purposes, and that the steaming capacity is ample for severe duty.

The boiler is of the extended wagon-top type, measuring 78 in. in diameter at the front end and 85⅞ in. at the dome ring. The firebox is radially stayed, and the front end of the crown is supported from a single T-bar hung on expansion links. A total of 460 flexible stays are placed in the throat, sides and back head. The furnace is equipped with a brick arch, and the fire door and grate shaker are pneumatically operated. The superheater is of the Schmidt type, and the large boiler flues numbering 36, are grouped in four horizontal and nine vertical rows; outside steam pipes convey the steam to the cylinders. The steam distribution is controlled by 16-in. piston valves.

The frames are vanadium steel castings, with separate rear

\*For description of Chesapeake & Ohio Mountain (4-8-2) type passenger locomotive see *Railway Age Gazette*, September 22, 1911, page 555.

sections of slab form. The main frames are braced, just ahead of the leading driving pedestals, by a large steel casting which, in addition to acting as a crosstie, supports the driving brake shaft. The upper frame rails, between the first and second pairs of drivers, are braced by the valve motion bearer, and between the second and third pairs by a broad steel casting which supports a boiler waist sheet. The splice between the main and rear frame sections is strengthened by a large transverse brace. This contains a suitable pocket for the radius bar pin of the rear truck, and carries the vertical expansion plate supporting the front end of the firebox. Transverse braces are also applied at the main driving pedestals. The main driving journals are 1 1/2 in. x 22 in., and the boxes are of the Cole pattern.

Vanadium steel is used for the main and side rods, and also for the rod straps; and heat treated steel for the piston rods, crank pins, driving axles and engine truck axles.

Preliminary trials with these locomotives indicate that they will be fully capable of meeting the service requirements. In both steaming and hauling capacity they rank among the most powerful six-coupled locomotives yet built, and they illustrate the exceptional capacity that can be obtained in the Pacific type, when track conditions permit high wheel-loads to be carried.

The general dimensions are given in the following table:

*General Data.*

Gage .....	4 ft. 8 1/2 in.
Service .....	Passenger
Fuel .....	Bit. coal
Tractive effort .....	44,000 lbs.
Weight in working order .....	282,000 lbs.
Weight on drivers .....	179,900 lbs.
Weight on leading truck .....	51,300 lbs.
Weight on trailing truck .....	50,800 lbs.
Weight of engine and tender in working order .....	443,000 lbs.
Wheel base, driving .....	13 ft.
Wheel base, total .....	34 ft. 1 in.
Wheel base, engine and tender .....	67 ft. 1 1/2 in.

*Ratios.*

Weight on drivers ÷ tractive effort .....	4.08
Total weight ÷ tractive effort .....	6.40
Tractive effort × diam. drivers ÷ heating surface* .....	629.00
Heating surface* ÷ grate area .....	85.80
Firebox heating surface ÷ evaporating heating surface, per cent. ....	6.60
Weight on drivers ÷ heating surface* .....	35.10
Total weight ÷ heating surface* .....	55.00
Volume both cylinders, cu. ft. ....	18.54
Heating surface* ÷ vol. cylinders .....	276.00
Grate area ÷ vol. cylinders .....	3.21

*Cylinders.*

Kind .....	Simple
Diameter and stroke .....	27 in. x 28 in.

*Valves.*

Kind .....	Piston
Diameter .....	16 in.
Lead .....	1/4 in.

*Wheels.*

Driving, diameter over tires .....	73 in.
Driving, thickness of tires .....	3 1/2 in.
Driving journals, main, diameter and length .....	1 1/2 in. x 22 in.
Driving journals, others, diameter and length .....	10 1/2 in. x 14 in.
Engine truck wheels, diameter .....	33 in.
Engine truck, journals .....	6 in. x 12 in.
Trailing truck wheels, diameter .....	49 in.
Trailing truck, journals .....	8 in. x 14 in.

*Boiler.*

Style .....	W. T.
Working pressure .....	185 lbs.
Outside diameter of first ring .....	78 in.
Firebox, length and width .....	114 in. x 75 1/2 in.
Firebox plates, thickness .....	3/4 in. and 1/2 in.
Firebox, water space .....	F, 5 in.; S. & B., 4 1/2 in.
Tubes, number and outside diameter .....	206—2 1/2 in.
Tubes, thickness .....	1/16 in.
Flues, number and outside diameter .....	36—5 1/2 in.
Flues, thickness .....	1/16 in.
Tubes and flues, length .....	20 ft. 6 in.
Heating surface, tubes .....	3,535 sq. ft.
Heating surface, firebox .....	220 sq. ft.
Heating surface, arch tubes .....	31 sq. ft.
Heating surface, total .....	3,786 sq. ft.
Superheater heating surface .....	879 sq. ft.
Grate area .....	59.6 sq. ft.

*Tender.*

Wheels, diameter .....	36 in.
Journals, diameter and length .....	6 in. x 11 in.
Water capacity .....	8,000 gals.
Coal capacity .....	14 tons

\*Equivalent heating surface equals evaporating surface (3,786 sq. ft.) plus 1.5 times superheater surface (879 sq. ft.), equals 5,105 sq. ft.

**EXPORT OF BRITISH AND AMERICAN RAILWAY EQUIPMENT.\***

American manufacturers of railway equipment have not been receiving their proper share of equipment orders of foreign railways. Railroad development in the older countries of Europe

**EXPORTS OF AMERICAN LOCOMOTIVES.**

Exports to—	1900	1900	1910	1911	1912	First 10 months 1913.
Europe .....	124,582	688,088	2,948	8,430	476,216	24,800
Canada .....	775,833	268,254	265,804	245,618	42,133	1,018,027
Central America .....	101,980	227,491	90,198	142,333	42,133	68,638
Mexico .....	1,073,970	230,821	412,447	622,189	116,221	62,441
Cuba .....	894,198	146,060	122,749	183,967	280,788	373,268
Other West Indies .....	51,365	7,180	37,810	86,495	62,573	.....
South America:						
Argentina .....	106,315	808,475	107,623	111,282	9,998	.....
Bolivia .....	.....	87,800	.....	2,000	18,840	.....
Brazil .....	622,986	806,241	1,048,388	1,199,301	1,261,354	2,078,680
Chile .....	887,088	22,400	45,079	51,880	64,861	.....
Colombia .....	95,644	14,755	23,798	65,023	40,030	.....
Ecuador .....	5,800	14,405	14,960	16,900	13,780	.....
Paraguay .....	9,808	.....	.....	.....	.....	.....
Peru .....	66,708	65,110	.....	11,878	18,943	.....
Uruguay .....	.....	.....	.....	4,968	.....	.....
Venezuela .....	.....	.....	.....	.....	6,445	.....
China .....	108,985	60,800	108,755	147,700	68,128	128,678
China—Japanese leased territory .....	.....	86,000	.....	.....	84,375	.....
Japan and Chosen (Korea) .....	2,029,872	737,780	29,985	615,054	229,111	1,268,246
Australasia .....	24,440	8,896	9,922	21,948	248,836	.....
Philippines .....	63,882	22,211	6,636	19,855	4,822	.....
Africa .....	13,300	2,887	86,785	417,700	177,875	.....
Other .....	25,748	86,789	.....	28,880	16,000	711,611
<b>Total .....</b>	<b>8,626,574</b>	<b>3,497,680</b>	<b>2,404,619</b>	<b>3,963,648</b>	<b>3,266,122</b>	<b>4,764,280</b>

\* Includes some of the countries given in the left-hand column.  
 † Includes steam and electric locomotives.  
 ‡ Does not include the 898,802 worth of electric locomotives exported.  
 § Steam locomotives only.

has been along lines radically different from those in the United States and distinct types of rolling stock have consequently

\*Taken from Foreign Markets for Railway Supplies and Equipment, published by the Bureau of Foreign and Domestic Commerce, Washington, D. C.



Pacific Type Passenger Locomotive for the Chesapeake & Ohio.

been evolved. American locomotives have been tried in a few European countries but it is claimed that they have not proved as satisfactory as the European models. In countries where railroads are a more recent development the capital has to a large extent been furnished by a few of the more important European countries, with the natural result that orders for rolling stock and other supplies are given to the country furnishing the necessary capital.

The value of American freight and passenger cars exported in the fiscal year 1908 was \$8,560,263; in 1909, \$3,464,952; in 1910, \$2,192,282; in 1911, \$5,472,648; in 1912, \$7,393,787, and in the first ten months of the fiscal year 1913, \$8,299,848. These figures compare with \$10,416,050 worth of British freight and passenger cars exported in 1910; \$9,408,428 in 1911, and \$12,947,997 in 1912. The figures for export of British and American locomotives are given in the accompanying tables. It will be seen that 1908 was the best year for American exports and that 1910 was the poorest. Since 1910 exports have been increasing and

EXPORTS OF BRITISH STEAM LOCOMOTIVES.

Exports to—	1910	1911	1912
Netherlands.....	134,185	47,386	2,151
France.....	1,490	1,106,618	25,647
Portuguese West Africa.....	47,299	88,658	97
Portuguese India.....	79,733	154,517	73,567
Spain.....	163,004	97,461	133,518
Turkey.....	30,747	180,999	12,283
Egypt.....	110,178	233,001	132,467
China.....	306,122	242,187	28,625
Japan.....	283,809	782,193	123,644
Philippines.....	10,653	64,462	24,196
Mexico.....	15,009	85,374	3,076
Peru.....	18,970	64,488	10,122
Chile.....	162,245	578,559	339,137
Brazil.....	496,189	653,420	674,828
Uruguay.....	259,215	23,194	41,560
Argentina.....	2,457,271	2,023,188	2,631,939
Other foreign countries.....	250,060	187,720	855,322
South Africa.....	1,342,449	381,845	821,344
India.....	1,609,235	2,511,228	1,881,231
Straits Settlements.....	32,241	87,863	23,680
Australia.....	78,137	878,664	1,872,942
Other British possessions.....	422,548	722,520	689,002
Total.....	8,310,759	11,230,040	10,399,778

1913 promises to be the record year for cars, if not for locomotives.

At present the need of foreign railways for new equipment is very pressing. In this connection the Manchester *Guardian* said recently, after telling of the congestion in the English car building plants: "The demand upon them is accentuated by the requirements of colonial railways. In the west coast of Africa district no one seems to have been prepared for the great flow of business which would ensue on the opening of railways. The congestion on the newest line running from Kano, the railhead in northern Nigeria, to the Niger river has been enormous. Cars have been placed on order with home firms which will take twelve or fifteen months to deliver so that no immediate relief may be looked for. The same thing is true of the Indian railways. The shortage of rolling stock for the trunk systems of India and Burma is inflicting a great loss and hardship on the commercial community. Great sums of money are being devoted to making good the deficiency. The great Argentine and Brazilian railway systems are constant buyers of rolling stock, placing large orders. There really seems to be a good opening for car builders as the way in which the world is opening out for railway traffic in all directions insures a constant demand in excess of the ordinary supply for many years to come."

RAILWAY ACTIVITY IN THE FRENCH CONGO.—According to a report published in Paris, the French government has agreed to a loan of \$35,000,000, required mainly for the construction of railways in the French Congo, and the scheme will probably be passed during the next session of the chamber of deputies. The new railways will include lines from Pointe Noire to Brazzaville, 362 miles; from Bangui to Fort Crampel, 216 miles, and from Ndjole to Kandjama, 193 miles. About \$2,500,000 is to be devoted to harbors and waterways and to wireless and ordinary telegraph systems.

### DROP TEST OF HEAT TREATED CHROME VANADIUM WHEELS.

An order for 400 heat-treated chrome-vanadium rolled steel wheels was recently placed by the Grand Trunk for the tenders of 50 Mikado type locomotives now building at the Montreal Locomotive Works. These tenders have a capacity of 9,000 gal. of water and 15 tons of coal. With a full load of coal and water, the estimated weight is 172,000 lbs., which gives an average load of 21,500 lbs. per wheel on the rail.

Some of these wheels, oil-treated in accordance with the manufacturers' approved practice, have recently been finished by the Standard Steel Works Company, and in order to thoroughly determine the strength and toughness of this type of wheel, severe drop tests in addition to the usual physical tests and chemical analyses were made of wheels selected at random. As these are the first tests of this character made on wheels of this kind, the results are of special interest. The wheels were made from two 50-ton heats of acid open-hearth steel. One wheel from each heat, numbers 9686 and 9683, was tested, the results being remarkably uniform. It was the original intention to test three wheels under the drop, one in a running position, one with the concave side of the plate up and one with the convex side of the plate up.

In the first test the wheel, made from heat 9686, was placed

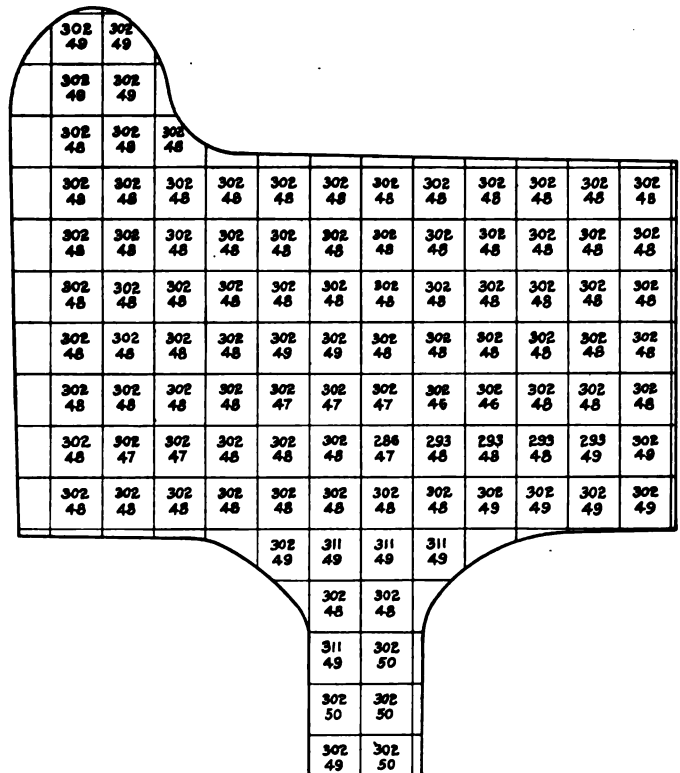

Results of Hardness Tests by the Brinell and Scleroscope Methods.

in a horizontal position and tested to destruction. In this test, though twice reversed, the wheel withstood a total of 1,254,000 foot-pounds before cracking or breaking. It was first placed under the drop with the concave or dished face of the plate up, in which position it offers least resistance to a blow or thrust. In this position it withstood without fracture or deflection the following blows from a 2,240 lb. tup dropping on the face of the hub and equivalent to a total of 515,200 foot-pounds of energy:

- 1 blow at 5 ft.
- 1 blow at 10 ft.
- 1 blow at 15 ft.
- 1 blow at 20 ft.
- 6 blows at 30 ft.

It was then placed with the convex side up, or in the position of its greatest resistance to side thrust. In this position



it was subjected without failure to 10 blows from a height of 30 ft., equivalent to 672,000 foot-pounds. Following this, the wheel was again placed in its original position and given one blow at 30 ft., at which it broke in four pieces. The accompanying illustration of one of the broken pieces shows the stringy, tough structure of the metal.

Following the drop test, the wheel was cut up and test pieces to determine the physical properties were taken tangentially from various points in the tread as shown in another of the illustrations. Physical tests of a piece taken across the rim from front to back were also made by the American Vanadium Company. The properties as shown by these various tests are given in Table 1. The chemical composition of the steel as shown by analysis is given in Table 2.

TABLE 1.—PHYSICAL PROPERTIES OF HEAT TREATED CHROME-VANADIUM ROLLED STEEL WHEELS.

Test No.	Elastic limit.		Elongation in 2 in.	Reduction of area.
	Lbs. per sq. in.	Tensile strength. Lbs. per sq. in.		
(Heat 9686)				
1	84,000	147,000	18.0 per cent.	43.5 per cent.
2	81,500	147,000	17.5 per cent.	34.0 per cent.
3	80,500	146,000	13.5 per cent.	29.5 per cent.
4	82,000	145,500	13.5 per cent.	36.0 per cent.
5	89,500	150,000	12.5 per cent.	31.0 per cent.
Across rim (front to back)...				
6	103,200	145,000	10.0 per cent.	19.3 per cent.
	100,000	148,000	14.5 per cent.	37.5 per cent.
(Heat 9683)				
1	87,000	153,500	12.0 per cent.	26.0 per cent.
2	119,000	167,500	12.0 per cent.	29.5 per cent.

Hardness tests both by the Brinell and Scleroscope methods were made by the American Vanadium Company on a

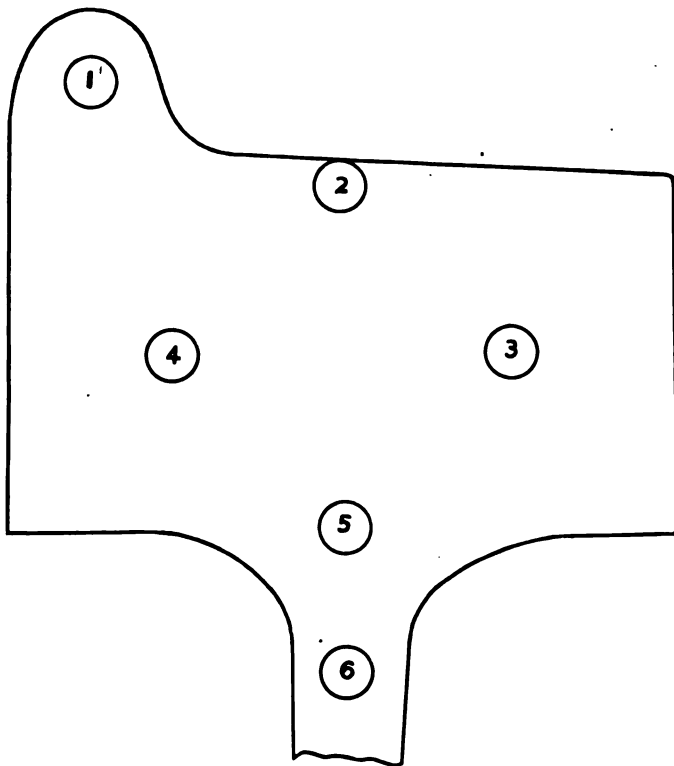

Points at Which Test Pieces Were Taken to Determine the Physical Properties of the Steel.

section of the wheel which included the entire rim and a portion of the plate. Both hardness tests were made at intervals of 3/8 in. over the entire section. The results are shown in one of the illustrations. As will be seen, the wheel shows a Brinell hardness of 302 and a Scleroscope of 48, practically uniform throughout the entire section, though a slightly higher degree of hardness was detected in the plate by the Scleroscope.

In the drop test of the second wheel, the wheel was first placed in a horizontal position with the concave face of the

plate up, the same as in the original position in the first test. In this position it was subjected to ten blows from the tup dropped from a height of 30 ft. on the face of the hub, equivalent to 672,000 foot-pounds. Under this treatment, no crack or fracture developed. It was then placed in a vertical or running position and given ten blows from a height of 30 ft. on the tread without any deflection or crack. At this point the tests were discontinued, as their severity had broken the drop test machine.

The physical properties of this wheel, made from heat 9683, as shown by tests made from pieces taken at the points shown in the illustration, are given in Table 1, while the chemical analysis is included in Table 2. As the two wheels met all the tests planned, no test was made of the third wheel which had been selected.

TABLE 2.—CHEMICAL COMPOSITION OF CHROME-VANADIUM WHEELS.

Heat No.	Carbon	Silicon	Phosphorus	Manganese	Sulphur	Chromium	Vanadium
9686...	.654	.30	.039	.63	.047	.992	.16
9683...	.603	.345	.032	.63	.048	.984	.16

Specifications have been adopted by the Standard Steel Works Company for heat treated chrome-vanadium wheels



Piece from Wheel Broken in Testing, Showing the Structure of the Metal.

for both steam and electric railway service. Except in the matter of tolerances, the two sets of specifications are practically identical and are in part as follows:

- 1.—Process: The steel shall be made by the acid open-hearth process.
- 2.—Discard: A sufficient discard shall be made from each ingot to insure freedom from injurious piping and segregation.
- 3.—Heat treatment: The wheels shall be allowed to become cold after rolling; shall be re-heated to the proper temperature to refine the grain and quenched in oil, and then re-heated to the proper temperature for tempering or drawing back.
- 4.—Chemical composition: The steel shall conform to the following requirements as to chemical composition:

Carbon .....	.50 to .65 per cent.	Vanadium .....	Over .16 per cent.
Manganese ..	.55 to .80 per cent.	Phosphorus..	Not over .05 per cent.
Silicon .....	.15 to .35 per cent.	Sulphur ...	Not over .05 per cent.
Chromium ..	.80 to 1.10 per cent.		

RAILWAY EARNINGS IN THE UNITED KINGDOM.—The total receipts from passenger and freight traffic in the United Kingdom in 1912 amounted to \$575,755,615, which represented the sum of \$24,561 per mile of line open for traffic at the end of the year, as against \$24,366 per mile in 1911. Although there was a decline in the tonnage of merchandise and minerals, and although fewer passengers were carried, the gross receipts for 1912 were the highest ever recorded in the history of British railways and showed a gain of about \$1,459,950 over 1911 for passenger traffic and approximately \$3,747,200 for freight traffic. Notwithstanding the significant falling off in the number of passengers carried as compared with 1911, the receipts from third-class passengers were larger than those of any previous year. A portion of the increase in the passenger receipts is attributed to the higher charges made for season, week-end, excursion, and other tickets which are issued at cheap rates. The total gross receipts of the British railways in 1912 approximated \$625,603,174, and the operating amounted to \$395,276,596. The net receipts were \$230,326,578 as compared with \$236,424,303 in 1911.

## General News.

The New York, New Haven & Hartford has been summoned to explain in the police court, at New York City, why it disobeys the law of New York, requiring that telegraphers shall be allowed two days off each month.

President Daniel Willard, of the Baltimore & Ohio, has ordered that no intoxicating liquors be carried or served in his official car. President Willard aims to set an example of respect for the rules of the operating department.

An appeal is made to the public by the Pennsylvania railroad to "stop, look, and listen." That is all very well for the part of the public which goes on foot or drives milk carts, but as for the automobilists, ought not the express trains to stop, look and listen for the honk?—*Springfield Republican*.

The semi-annual meeting of representatives of the operating, traffic and freight claim departments of the Atchison, Topeka & Santa Fe to discuss plans for reducing loss and damage to freight will be held at St. Joseph, Mo., on September 30. F. A. Lehman, assistant to Vice-President Storey, is chairman of a loss and damage committee.

The Southern Pacific has posted on every station bulletin board and in all of its freight offices copies of the letter issued by the California State Railroad Commission calling on shippers to promptly load and unload freight cars to prevent a shortage. Beneficial results from appeals sent out by commercial bodies in California are already evident.

William J. Borland has been appointed safety engineer of the Western Maryland, and has been instructed to organize "Safety First" committees on all divisions of the road. Mr. Borland, who is the son of W. P. Borland, assistant chief of the safety appliance division of the Interstate Commerce Commission, has had experience in railroad work and also on the editorial staff of the *Baltimore American*.

Prof. Henry C. Adams, of the University of Michigan, is going to China to act as adviser to a governmental commission which has been appointed to standardize the accounts and records of the government railroads. He will sail October 9. It was announced recently that Professor Adams had been appointed a member of the Board which is to advise the Interstate Commerce Commission on valuation matters.

The Electric Division of the New York Central & Hudson River now extends on the main line from New York northward to Harmon, 33 miles, and a considerable number of through trains change engines at Harmon, instead of High Bridge, as formerly. Seven additional trains were put on this schedule this week. The northbound Empire State express, which for several years has stopped at High Bridge, now passes that place without stopping and makes a stop at Harmon.

Timothy J. Sullivan, of Springfield, Mass., has signed a contract with New York capitalists to go to San Domingo, to superintend the construction of 180 miles of railroad and an extensive mileage of wagon road, the plan, as a whole, contemplating the expenditure of \$20,000,000. Mr. Sullivan was formerly road-master on the Boston & Albany, but left railroad service in 1905, and since then has been a retail coal dealer in Springfield. His contract binds him to stay in San Domingo four years at \$12,000 a year.

The Arbitration Board, considering trainmen's wages, has continued hearing testimony in favor of the conductors and trainmen concluding that part of its work on Wednesday of this week. Facts and arguments were presented by Charles S. Brigham, a passenger conductor of the New York, New Haven & Hartford; Claude Dillon, a freight conductor of the Baltimore & Ohio, W. J. Burke, of the same road; J. J. Foster, a yard brakeman of the Buffalo, Rochester & Pittsburgh, and H. B. Schwab, a brakeman on the Pennsylvania.

Near Wileys, Ohio, on September 9, the westbound "24 hour St. Louis" express of the Pennsylvania, train No. 31, was derailed, and one car was overturned. All the cars were of steel and no passenger was killed. The fireman was fatally scalded and 14 passengers, 10 dining car employees, 7 Pullman employees

and two postal clerks were injured. This part of the road was not washed out in the March floods, as was reported. The derailment occurred on a curve of 1 deg. 43 min. Two rails were found broken but they were beyond the point of derailment and there is no evidence that the derailment was caused by a broken rail.

The Louisville & Nashville has begun a suit in the Federal court in Florida, to test the validity of the law of that state, passed at the last session of the legislature, requiring all locomotives to be equipped with headlights of 15,000 candle power. The road claims that this law infringes the authority of the federal government, which has exclusive jurisdiction over locomotives used in interstate commerce. It is also set forth that such brilliant lights would introduce an element of danger, as they would obscure signal lights; moreover, the road would be put to an initial expense of \$15,000 in the state of Florida, and the cost of maintenance of the lights would be \$300 per year per engine.

The New York Central is sending out a circular, to be posted in all its stations, which calls attention to the fact that about 400 persons are killed annually in the state of New York while trespassing on the railroad tracks. This is about four times the number killed at grade crossings. This notice is printed on a sheet about 8 in. x 10½ in., and is headed "DO NOT WALK ON THE TRACK." It contains the usual arguments and warnings against endangering one's life by unnecessary walking on the railroad right of way and is in type large enough to be read some little distance away. Agents are instructed to deliver a supply of the placards to the schools and also to manufacturers, shippers and others who might aid the railroad in bringing the trespassing class to their senses.

Attorney General McReynolds appeared before the Senate Committee on appropriations at Washington on Tuesday of this week to argue in favor of the retention of the Commerce Court. Voicing what are believed to be the views of President Wilson, as well as of the attorney general himself, Mr. McReynolds declared that the Commerce Court, instead of being abolished, should have its powers enlarged. But little change in the law would be necessary to make the court satisfactory to all reasonable critics. Mr. McReynolds intimated that action by Congress throwing the judges out of office, would be unconstitutional. Congress has as much right to refuse to appropriate salaries for other federal judges as to refuse to provide for the judges who are assigned to the Commerce Court.

The New York, New Haven & Hartford is building at South Boston a new fish wharf, 1,200 ft. long. This wharf is to provide for the extensive traffic in fish which is now done mainly at the old T Wharf, one of Boston's ancient landmarks. The New Haven road carries from three to 15 carloads of fish from Boston to New York every night, by freight (not express) and the train makes the trip of 234 miles in eight hours five minutes, delivering its freight at Harlem river at 1:50 a. m. Every day from 50 to 300 tons of fish leave the South Boston terminal on this train bound to New York fish dealers, and a great deal of it has to be put aboard in the last five or ten minutes. It is not until well on in the afternoon that the New York fish dealers can decide just how much fish to order. Frequently it is four o'clock when some of the orders are received in Boston, and they are for fish that in some cases is wanted for breakfast the next morning in a New York hotel.

The New Haven road reports that nearly \$50,000 worth of articles lost in the North Haven wreck have been recovered by the railroad's police department. The number of articles scattered and lost at the time of the accident ran up into the thousands, but only twenty articles or groups of articles are now alleged to be missing. Such was the nature of this accident that an unusual amount of personal belongings was strewn about. Many of these when recovered lacked means of identification. A force of special agents of the New Haven road, working in conjunction with the New Haven and Wallingford police, took charge of the work of collecting these articles immediately. Included in the thousands of articles brought together were over 400 pieces of jewelry, ranging in value all the way from \$1 to \$1,000. There were over thirty watches and fifty rings, besides brooches, pins and one pearl necklace. All articles which could

be identified at once were restored as soon as possible to the owners or their authorized representatives. A force of ten men in the special agent's department was busy for over two weeks on this matter.

#### Twelve Passengers Killed in France.

A press despatch from Nice, France, September 17, reports the wrecking of three electric cars, filled with passengers, by a derailment on a bridge near the village of Villeneuve-Loubet, the cars falling 40 ft. to a ravine below. Besides the 12 killed there were 30 or more injured.

#### A Correction.

Through an error, the paper on Some Freight Car Troubles, abstracted in the *Railway Age Gazette*, September 19, page 499, was credited to the Western Railway Club instead of the Central Railway Club.

#### Fifty Persons Killed in Mexican Train Wreck.

A press despatch from Laredo, Tex., reports that on Friday, September 19, rebels wrecked a passenger train with dynamite at a point 60 miles south of Saltillo, Mex., causing the death of 50 persons, of whom 40 were Federal soldiers and 10 second class passengers. The surviving passengers were robbed.

#### Airship Flight from Europe to Africa.

Roland G. Garros, the French aviator, on Tuesday last, flew across the Mediterranean Sea from Saint Raphael, near Marseilles, France, to Bizerta, near Tunis, making the distance of 558 miles in seven hours 53 minutes. This is at the rate of about 70 miles an hour. Garros refused the offer of the French navy to furnish boats to safeguard his flight. For a considerable part of his journey he was not far from the coast of Corsica or Sardinia.

#### White Flags at Highway Crossings.

At South Norwalk, Conn., recently, an automobile was struck by a train of the New York, New Haven & Hartford, at a crossing, and three persons were killed. It is now reported that the New Haven Automobile Club has taken action on the fact, or assumption, that Mr. Miller, the driver of the automobile, thought the waving of a white flag by the crossing watchman was intended to indicate that the passage was clear. The club has voted to request the railroad company to change its flagging system.

#### Safety First on the Southern Pacific.

The principles of modern advertising are employed by the Southern Pacific in its "Safety First" campaign. Not only is every effort being made to see that operating rules are enforced, but bulletins, paychecks and other papers, go out bearing a striking escutcheon containing the words SAFETY FIRST. Buttons with a like design are worn by the men. "Display" signs are to be posted on bulletin boards wherever employees congregate. On all divisions, photographs and lantern slides are being prepared to illustrate faulty conditions. The Southern Pacific reports that it has not killed a passenger on any of its passenger trains for the last five years. President Wm. Sproule is devoting personal attention to this campaign. He says, "human life and limb are the dearest things we have, and this most certainly applies to employees as well as to patrons."

#### "Safety First" Clock.

A novel clock with the letters of the words "Safety First" utilized in place of the usual numerals, has been constructed by W. C. Egan, general claim agent of the Baltimore & Ohio. The clock is of the "grandfather" style, and is 6 ft. high; and across its face is the legend "Baltimore & Ohio," the initial "B" taking the place of the numeral 9, thereby completing the complement of 12 numerals. Above the dial is a semaphore arm, and twice each day the clock calls attention to the three essentials of safe railroading. At 10 a. m. and 4 p. m., the semaphore drops to the green, or caution position, a reminder to engineers to proceed with caution. Next a whistle blows

twice, an acknowledgment that the signal is seen and will be heeded. After this a bell rings, being a reminder that no engine may move until its bell has been rung. And when the bell stops ringing a curtain drops from behind the clock displaying ten cardinal safety-first "don'ts."

#### Traffic at South Station, Boston.

The Grand Central terminal in New York City is the largest railway station in the country; but Boston's South station still claims the distinction of being the busiest terminal in America, if not in the world.

Statisticians of the New York, New Haven & Hartford report that in the year ending on the 30th of June, last, 16,007,582 more people passed through the South station than the Grand Central. The total number of passengers in and out of the South station was 38,411,507; total in or out of the Grand Central, 22,405,295; a daily average for the South station of 105,237 persons, and for the Grand Central terminal, 61,379. The figures by months are as follows:

	South Station		Grand Central.
	N. Y. N. H. & H.	B. & A.	
July, 1912	2,284,509	780,218	1,799,846
August	2,315,690	892,066	1,837,554
September	2,280,484	815,284	1,871,229
October	2,590,245	917,630	1,936,891
November	2,426,490	847,229	1,820,461
December	2,424,052	851,708	1,865,416
January, 1913	2,401,067	841,949	1,861,352
February	2,130,615	754,470	1,618,526
March	2,425,051	853,869	1,902,549
April	2,397,717	850,869	1,896,327
May	2,451,496	866,208	2,023,402
June	2,219,983	793,160	1,971,742
Total	28,347,399	10,064,108	22,405,295

In the number of trains handled the South station also continues to be ahead, owing to the fact that the traffic is distributed over more lines. Eleven or more main tracks converge in the Boston terminal, whereas all of the trains to and from the New York station must be accommodated by four tracks.

The number of trains entering and leaving the South station in the 24 hour period on week days is 843; at the Grand Central it is 450. In the rush hour at the South station 91 trains leave in 60 minutes.

In the year under review, 226,391 more people departed from the Grand Central terminal than arrived there, and there was an increase in the total number using the station of 842,674 over the previous year.

The new Grand Central terminal has hardly begun to do the business for which it was designed; while 62,000 people use it daily at the present time, the station when completed will have a capacity to handle 70,000 people in one hour. Twenty-one tracks have still to be completed and put in use.

The travel in and out of the North station of the Boston & Maine at Boston for the last fiscal year was 29,510,875.

#### Admirals and Locomotive Runners.

The traveling public trusts that the locomotive engineers and the New Haven road will have no permanent differences concerning rules and discipline. On many points the public may not be able to pass judgment, owing to lack of expert knowledge, but it will strike most people that the engineers take an untenable position in holding that all engineers who have had a certain amount of experience are equally competent for all kinds of work. There are differences among individuals. If the road is charged with the transportation of the president of the United States, for example, it should be the right of the general manager to place in the locomotive an engineer reputed to be strong in the qualities of prudence. All rear-admirals in the navy have the same rank and pay; all are presumed to be competent to command a squadron or a fleet. But how absurd it would be to forbid the president of the United States to pick for a particular naval service the one of those rear-admirals believed to be most likely to insure its success.—*Springfield Republican*.

#### A Simple Calculation.

We have spent \$100,000,000 in improvements in the past three years. This has practically given a low grade line from Chicago to the Atlantic seaboard, increasing the train loading capacity 50 per cent. in that period. There should be a horizontal in-

crease of 5 per cent. in freight rates. I have every confidence in the Interstate Commerce Commission, and believe that the railroad case will meet favorable consideration. The increase in the Baltimore & Ohio payroll, the results of agreements, arbitration, etc., is \$5,000,000 a year, which with increased taxes and other legislative enactments makes a total of \$10,000,000 a year additional which the company is obliged to expend before any part of the profits can be applied to interest charges.—*Daniel Willard, President, B. & O.*

**Prospects in Oklahoma.**

Since statehood and the adoption of the constitution, railroad building in Oklahoma has been a myth; and practically the only construction was the completion of the Wichita Falls & Northwestern, which had been begun about a year before Oklahoma became a state. Since the railroad section of the constitution was amended on August 5 of this year, through a referendum vote, railroad talk in the state has been revived and there are evidences that development will come soon and certain.

Immediately after the result of the election was announced it became known that the Missouri, Kansas & Texas had taken over the Wichita Falls & Northwestern, such transaction being impossible under the constitution as it was formerly. Then came the announcement that the Santa Fe was negotiating with the Fort Smith & Western, and finally that the Santa Fe would take over the Oklahoma Central. The latter two propositions are considered important in railroad circles. If consummated these will make two splendid feeder lines for the Santa Fe.

The Fort Smith & Western crosses the Santa Fe at Guthrie, and then goes straight east to Fort Smith. This road about a year ago secured an option on the St. Louis, El Reno & Western, a short piece of road from Guthrie to El Reno that never paid as an individual line. It is understood that the objective point of the Santa Fe is Cairo, Ill., and by acquiring the Fort Smith & Western a big step in this direction will have been taken. The Fort Smith & Western was built in 1901 by H. C. Frick and a party of Pennsylvania capitalists for the purpose of developing Frick's coal fields in eastern Oklahoma. Coke was to be made out of the coal and shipped to Mexico. Frick and his syndicate were and are still heavily involved in producing coking coal in Pennsylvania, and the plan was to reduce the haul to Mexico by developing the fields in eastern Oklahoma. About the time the development work was begun Frick became associated with the steel trust and the Oklahoma project was dropped.

With the control of the Oklahoma Central by the Santa Fe other rich coal fields in the southern portion of the state may be reached. Also a rich agricultural section has been developed since the building of the road. This line also crosses the Santa Fe in McClain county. These deals are now possible because of the abolition of the constitutional provision prohibiting one road taking over another.

Within the past week talk concerning the construction of the M. O. & G. from Henryetta to this city has been revived. The line is owned by William Kenefick. Bonuses were secured a year ago from local business men for the purchase of terminal yards here, but held in abeyance pending realization on financial deals with French capitalists. It is said now that this money may be secured at any time and that work would then be commenced. Mr. Kenefick, who has been in France for several months, returned the past week, and accompanied by a number of French capitalists who came back with him, has been making trips over the proposed routes.

Since the election many new interurban lines have been projected, especially in the southern part of the state, and for the first time since the town was started, several years ago, people of Cheyenne this week heard the whistle of a locomotive. A branch of the Clinton & Oklahoma Western, known as the "Alfalfa Route," has been built into the town. It was completed this week.—*From a Correspondent at Oklahoma City.*

**Connecticut Report on North Haven Collision.**

The Public Utilities Commission of Connecticut has issued its report on the rear collision at North Haven, September 2. The commission assigns six specific causes, as follows: Lack of adequate signal system; bunching of six passenger trains in a section of 10 miles; reckless running on the part of Engineman

Wands; failure of Flagman Murray to go back a sufficient distance to protect his train; indifference of Conductor Adams, and Engineman Miller's reckless running in a fog.

Pending the completion of the new signals on the New Haven-Springfield section of the road the commission recommends that fixed boards be set up 2,500 ft. in the rear of each automatic signal except those which have distant indications. The report says that there is an apparent lack of friendly co-operation between the directing and operating forces of the railroad. Many recommendations are made, including the rigid enforcement of rules for flagging.

**Which is the Trust?**

Frank J. Warne testifying before the Board of Arbitration, alleges that fifty-two railroads in interest are controlled by eighteen men. These men may or may not control the railroads. But there can be no question of the control of the railroad labor. These fifty-two railroads cannot run without labor. Their labor is absolutely controlled, and independently of the alleged railroad trust, by four men. The eighteen alleged monopolists cannot hold up public business to secure their ends. The four men possess exactly that power.

Here is the list and let an honest public say which set of tyrants it prefers:

CAPITAL.	LABOR.
George F. Baker,	Warren S. Stone,
William C. Brown,	(Engineers,)
J. P. Morgan,	W. S. Carter,
William Rockefeller,	(Firemen,)
William H. Newman,	W. G. Lee,
Samuel Rea,	(Trainmen,)
James Stillman,	A. B. Garretson,
W. K. Vanderbilt, Jr.,	(Conductors.)
Oscar Murray,	
Charles S. Mellen,	
L. C. Ledyard,	
William Skinner,	
L. F. Loree,	
John P. Green,	
N. B. Ream,	
Joseph Wood,	
Chauncey Depew,	
W. K. Vanderbilt.	

Accepting, for the sake of argument, the far-fetched charge of a monopoly of railroad control against the gentlemen named, what is the danger of it compared to the irresponsible autocracy of the four men named in the parallel column?—*Wall Street Journal.*

**Electrification of Pennsylvania Tracks at Philadelphia.**

The president of the Pennsylvania Railroad Company announces that the electrification of suburban passenger service on the New York division from Broad Street station, Philadelphia, to Chestnut Hill, 12 miles, has been authorized. It is expected that the work will be completed by the fall of 1914, and will involve an expenditure, including multiple unit equipment, of \$1,250,000. Until traffic between Allen Lane and Fort Hill on the Fort Washington branch warrants its electrification, it is intended to continue the steam service between those points.

The company is endeavoring to meet as rapidly as practicable the problem of the congestion at Broad Street station. Without waiting for the enlargement of the station, it has been determined that the electrification of the Chestnut Hill branch, in connection with the electrification of the main line to Paoli, offers the most prompt and effective plan, particularly as it will be four or five years before the city subway can be built under Broad street and rapid transit operated as far as North Philadelphia station. Other steps already taken in this general plan of improvement are: First, the electrification of the main line to Paoli, 20 miles. Second, the acquisition of property for widening Broad Street station, and the enlargement of the concourse within the station. Third, construction of eight tracks and high level island platforms at North Philadelphia. Fourth, new passenger facilities and track connection at North Philadelphia for the Chestnut Hill branch, and fifth, a new and enlarged masonry arch bridge and additional tracks over the Schuylkill river at Girard avenue (main line of the New York division).

The foregoing improvements are now under way or in large measure completed. Pending the widening of Broad Street sta-

tion, which is dependent upon negotiations with the city, and the further development of the company's final terminal plans, it is essential to obtain as quickly as possible greater train capacity in the present station. There are now about 85 Paoli steam trains each day in and out of Broad Street station, and 66 trains to and from the Chestnut Hill Branch, all of which will be operated by electricity, thus affording immediate relief.

#### Prevention of Fires on the Western Pacific.

C. M. Levey, general manager of the Western Pacific, has furnished locomotive enginemen with cards, to be thrown off for the purpose of notifying section men of the need of going to a fire, which require no marking. On the edge of the card there are six half perforated notches, numbered from one to six; and the tearing out of the perforated strip by a push of the finger against, for example, the figure 4, indicates that the fire is four miles to the rear of the point where the card is thrown off.

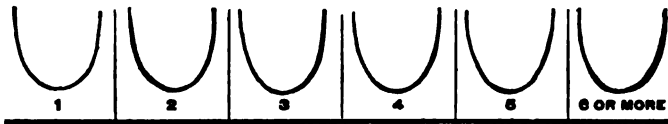

LOCATION OF FIRE IN MILES TO THE REAR OF POINT WHERE CARD IS THROWN OFF IS INDICATED BY NUMBERS CHECKED ABOVE.

Enginemen are instructed to use these cards in case of all grass fires, whether on the right of way or on adjacent land. Men are to be sent at once to the fire, and the section master and the road master are directed to make prompt report to the superintendent, who will make any necessary investigation and then send the card, with his report, to the claim agent.

#### International Refrigeration Exposition.

In connection with the International Refrigeration Congress, held in Chicago last week, an exposition of machinery, materials and processes used in refrigeration, was held at the International Amphitheater at the Union Stock Yards. The exhibits opened on September 17, and will remain open until October 1. The position includes an exhibit of foods and perishable products by the United States Department of Agriculture shown in a 150 ft. glass wall refrigerator. Among the exhibits of interest to railways were the following:

- American Rolling Mill Company, Middletown, Ohio.—American Ingot iron products. Represented by G. L. Ahlbrandt and G. L. Sheets.
- Barrett Manufacturing Company, New York, N. Y.—Anhydrous ammonia cylinders and aqua ammonia drums; bottles of sulphate ammonia. Represented by J. P. Reilly, G. H. Thomson, Nicholas Wolf, Sr., and R. V. Irwin.
- Crane Company, Chicago, Ill.—Valves, fittings and steam traps sectionally cut, pipe machine. Represented by C. A. Spencer, J. A. Nimwegen and F. D. Fenn.
- Garlock Packing Company, Palmyra, N. Y.—Fibrous ammonia and other packings in spiral form, sheet packing, hydraulic and flax packings, metal packings, gaskets. Represented by H. F. Rall, C. C. Humberstone and Stanley McDole.
- Gold Car Heating and Lighting Company, New York, N. Y.—Car equipped with heat storage and lighting system; sectional parts of car heater. Represented by W. H. Stocks and A. D. Stuver.
- Goldschmidt Thermit Company, New York, N. Y.—Pipe welding equipment; samples and pictures of welded material; thermit; demonstration of pipe welding. Represented by Henry S. Mann and Alfred Beaulieu.
- Graver, Wm., Tank Works, Chicago, Ill.—50 ton Bartlett-Graver water softener and purifier in operation; photographs of brine tanks, steel stacks, ice tanks and steel plate work. Represented by W. F. Graver, K. W. Bartlett and C. Dahlquist.
- Johns-Manville, H. W., Company, New York, N. Y.—Sheet and granulated cork; pipe and boiler covering; membrane waterproofing; mastic flooring; roofing; ammonia, steam and water packings; boiler preservative; asbestos and magnesia products; insulating and building papers; electrical supplies. Represented by C. D. Havenstrite.
- Kennicott Company, The, Chicago, Ill.—Kennicott-Jewell pressure filter; water weigher; water softener. Represented by F. S. Dunham, W. D. Hawkins, T. G. Windes, Jr., and H. C. Ager.
- Lehon Roofing Company, Chicago, Ill.—Roofing. Represented by Thomas Lehon.
- Moore Patent Car Company, St. Paul, Minn.—Ventilator-heater-refrigerator car. Represented by C. A. Moore, G. F. Thomas and E. E. Squier.
- National Tube Company, Pittsburgh, Pa.—Samples butt and lap welded ammonia pipe; "Spellerizing" process; sample pieces of skelp; threading dies, old and modern types; stand of "National" pipe. Represented by L. F. Hamilton, B. F. Bart and H. W. Weber.
- Otto Gas Engine Works, Philadelphia, Pa.—Gas and gasolene engines.
- Pacific Fruit Express, San Francisco, Cal.—Standard ventilated refrigerator car.
- Solvay Process Company, Syracuse, N. Y.—75 per cent. calcium chloride; demonstration of uses of calcium chloride. Represented by Fred S. Lightall, Claude Cole and H. W. Jordan.

- Taylor Instrument Company, Rochester, N. Y.—Temperature indicating, controlling and recording instruments; hydrometers. Represented by H. W. Maurer, Fred K. Taylor and J. A. Sutherland.
- Union Fibre Company, Winona, Minn.—Standard refrigerator car insulated with Linofelt; samples of Linofelt, Fibrofelt, Lith and Union cork board. Represented by E. G. Boynton, J. W. Booth, A. S. More, F. C. Landon, J. J. Brown and H. W. Leeds.
- Union Insulating Company, Chicago, Ill.—Pure cork boards; composition cork boards; waterproof lith boards; rock cork boards, Fibrofelt sheets. Represented by S. E. McPartin, E. S. Main, J. H. Bracken, C. F. Rogers and N. B. Webster.
- Westinghouse Electric & Manufacturing Company, Pittsburgh, Pa.—Motors and generators. Represented by W. H. Patterson and A. L. Hampton.
- White Enamel Refrigerator Company, St. Paul, Minn.—Full size section of refrigerator car showing Bohn all steel collapsible bulkheads, hatch ventilators and plugs; samples Flaxinum car insulation. Represented by Gebhard Bohn, G. C. Bohn and J. H. Burwell.

#### Railway Fire Protection Association.

The proposal to establish an association for the purpose indicated by the foregoing title, which was made public some months since has now so far taken shape that a meeting for organization is to be held at Hotel Sherman, Chicago, October 7 and 8 next. Eight instructive addresses are already on the program, as follows: Charles N. Rambo, superintendent of the Mutual Fire, Marine & Inland Insurance Company, on "Spark Hazard"; B. W. Dunn, of the Bureau of Explosives, on "Handling of Explosives"; N. S. Dunlop, of the Canadian Pacific, on "Causes of Fire"; Anson Murphy, Alabama Great Southern, "Construction of Buildings"; B. S. Mace, Baltimore & Ohio, on "Fire Organization," and P. Hevener, Rock Island, on "How a Locomotive May be Used to Extinguish a Fire."

W. H. Merrill, manager of the Underwriters' Laboratories, Chicago, will make some tests for the benefit of the members of the association, plans having been made for a visit to the laboratories Tuesday afternoon.

The secretary of the Committee on Organization, is C. B. Edwards, fire insurance agent of the Mobile & Ohio, Mobile, Ala. Most of the members of the committee come from railroads in the southern states, but they desire to enlist the interest of all railroads; and, indeed, they have already received such assurance that they feel confident of success.

#### MEETINGS AND CONVENTIONS.

The following list gives names of secretaries, dates of next or regular meetings, and places of meeting.

- AIR BRAKE ASSOCIATION.—F. M. Nellis, 53 State St., Boston, Mass. Next convention, May, 1914.
- AMERICAN ASSOCIATION OF DEMURRAGE OFFICERS.—A. G. Thomason, Boston, Mass. Convention, May 19, 1914, St. Louis.
- AMERICAN ASSOCIATION OF GENERAL PASSENGER AND TICKET AGENTS.—W. C. Hope, New York. Annual meeting, October 14-15, Philadelphia, Pa.
- AMERICAN ASSOCIATION OF FREIGHT AGENTS.—R. O. Wells, East St. Louis, Ill. Next convention, April 21, Houston, Tex.
- AMERICAN ASSOCIATION OF RAILROAD SUPERINTENDENTS.—E. H. Hartman, St. Louis, Mo.; 3d Thursday and Friday in May.
- AMERICAN ELECTRIC RAILWAY ASSOCIATION.—H. C. Donecker, 29 W. 39th St., New York. Next convention, October 13-17, Atlantic City, N. J.
- AMERICAN ELECTRIC RAILWAY MANUFACTURERS' ASSOC.—H. G. McConaughy, 165 Broadway, New York. Meetings with Am. Elec. Ry. Assoc.
- AMERICAN RAILWAY ASSOCIATION.—W. F. Allen, 75 Church St., New York. Next meeting, November 19, 1913, Chicago.
- AMERICAN RAILWAY BRIDGE AND BUILDING ASSOCIATION.—C. A. Lichty, C. & N. W., Chicago. Convention, October 21-24, 1913, Montreal.
- AMERICAN RAILWAY ENGINEERING ASSOCIATION.—E. H. Fritch, 900 S. Michigan Ave., Chicago. Next convention, March 17-20, Chicago.
- AMERICAN RAILWAY MASTER MECHANICS' ASSOCIATION.—J. W. Taylor, Old Colony building, Chicago.
- AMERICAN RAILWAY TOOL FOREMEN'S ASSOCIATION.—A. R. Davis, Central of Georgia, Macon, Ga.
- AMERICAN SOCIETY FOR TESTING MATERIALS.—Prof. E. Marburg, University of Pennsylvania, Philadelphia, Pa.
- AMERICAN SOCIETY OF CIVIL ENGINEERS.—C. W. Hunt, 220 W. 57th St., New York; 1st and 3d Wed., except June and August, New York.
- AMERICAN SOCIETY OF ENGINEERING CONTRACTORS.—J. R. Wenlinger, 11 Broadway, New York; 2d Tuesday of each month, New York.
- AMERICAN SOCIETY OF MECHANICAL ENGINEERS.—Calvin W. Rice, 29 W. 39th St., New York.
- AMERICAN WOOD PRESERVERS' ASSOCIATION.—F. J. Angier, B. & O., Baltimore, Md. Next convention, January 20-22, 1914, New Orleans, La.
- ASSOCIATION OF AMERICAN RAILWAY ACCOUNTING OFFICERS.—C. G. Phillips, 143 Dearborn St., Chicago. Annual meeting, May 28, Atlantic City, N. J.
- ASSOCIATION OF RAILWAY CLAIM AGENTS.—C. W. Egan, B. & O., Baltimore, Md. Next convention, May, 1914, St. Paul, Minn.
- ASSOCIATION OF RAILWAY ELECTRICAL ENGINEERS.—Jos. A. Andreucetti, C. & N. W. Ry., Chicago. Annual convention, October 18-24, Chicago.
- ASSOCIATION OF RAILWAY TELEGRAPH SUPERINTENDENTS.—P. W. Drew, 112 West Adams St., Chicago. Next convention, May 20-23, New Orleans, La.
- ASSOCIATION OF TRANSPORTATION AND CAR ACCOUNTING OFFICERS.—G. P. Conard, 75 Church St., New York. Next meeting, December 9-10, Galveston, Tex.
- ASSOCIATION OF WATER LINE ACCOUNTING OFFICERS.—W. R. Evans, Chamber of Commerce, Buffalo, N. Y. Annual meeting, October 8, Philadelphia, Pa.

# Traffic News.

**BRIDGE AND BUILDING SUPPLY MEN'S ASSOCIATION.**—H. A. Neally, Joseph Dixon Crucible Co., Jersey City, N. J. Meeting with American Railway Bridge and Building Association.

**CANADIAN RAILWAY CLUB.**—James Powell, Grand Trunk Ry., Montreal, Que.; 2d Tuesday in month, except June, July and Aug., Montreal.

**CANADIAN SOCIETY OF CIVIL ENGINEERS.**—Clement H. McLeod, 413 Dorchester St., Montreal, Que.; Thursday, Montreal.

**CAR FOREMEN'S ASSOCIATION OF CHICAGO.**—Aaron Kline, 841 North 50th Court, Chicago; 2d Monday in month, Chicago.

**CENTRAL RAILWAY CLUB.**—H. D. Vought, 95 Liberty St., New York; 2d Thurs. in Jan. and 2d Fri. in March, May, Sept., Nov., Buffalo, N. Y.

**CIVIL ENGINEERS' SOCIETY OF ST. PAUL.**—L. S. Pomeroy, Old State Capitol building, St. Paul, Minn.; 2d Monday, except June, July, August and September, St. Paul.

**ENGINEERS' SOCIETY OF PENNSYLVANIA.**—E. R. Dasher, Box 704, Harrisburg, Pa.; 1st Monday after 2d Saturday, Harrisburg, Pa.

**ENGINEERS' SOCIETY OF WESTERN PENNSYLVANIA.**—E. K. Hiles, Oliver building, Pittsburgh; 1st and 3d Tuesday, Pittsburgh, Pa.

**FREIGHT CLAIM ASSOCIATION.**—Warren P. Taylor, Richmond, Va. Next convention, May 20-22, Galveston, Tex.

**GENERAL SUPERINTENDENTS' ASSOCIATION OF CHICAGO.**—E. S. Koller, 226 W. Adams St., Chicago; Wed. preceding 3d Thurs., Chicago.

**INTERNATIONAL RAILWAY CONGRESS.**—Executive Committee, 11, rue de Louvain, Brussels, Belgium. Convention, 1915, Berlin.

**INTERNATIONAL RAILWAY FUEL ASSOCIATION.**—C. G. Hall, 922 McCormick building, Chicago. Annual convention, May 18-22, Chicago.

**INTERNATIONAL RAILWAY GENERAL FOREMEN'S ASSOCIATION.**—Wm. Hall, 829 West Broadway, Winona, Minn. Next convention, July, Chicago.

**INTERNATIONAL RAILROAD MASTER BLACKSMITHS' ASSOCIATION.**—A. L. Woodworth, Lima, Ohio. Next convention, third Tuesday in August.

**MAINTENANCE OF WAY & MASTER PAINTERS' ASSOCIATION OF THE UNITED STATES AND CANADA.**—W. G. Wilson, Lehigh Valley, Easton, Pa. Next convention, November 18-20, Louisville, Ky.

**MASTER BOILER MAKERS' ASSOCIATION.**—Harry D. Vought, 95 Liberty St., New York.

**MASTER CAR BUILDERS' ASSOCIATION.**—J. W. Taylor, Old Colony building, Chicago.

**MASTER CAR AND LOCOMOTIVE PAINTERS' ASSOC. OF U. S. AND CANADA.**—A. P. Danc, B. & M., Reading, Mass.

**NATIONAL RAILWAY APPLIANCE ASSOC.**—Bruce V. Crandall, 537 So. Dearborn St., Chicago. Meetings with Am. Ry. Eng. Assoc.

**NEW ENGLAND RAILROAD CLUB.**—W. E. Cade, Jr., 683 Atlantic Ave., Boston, Mass.; 2d Tuesday in month, except June, July, Aug. and Sept., Boston.

**NEW YORK RAILROAD CLUB.**—H. D. Vought, 95 Liberty St., New York; 3rd Friday in month, except June, July and August, New York.

**NORTHERN RAILROAD CLUB.**—C. L. Kennedy, C., M. & St. P., Duluth, Minn.; 4th Saturday, Duluth.

**PEORIA ASSOCIATION OF RAILROAD OFFICERS.**—M. W. Rotchford, Union Station, Peoria; 2d Thursday.

**RAILROAD CLUB OF KANSAS CITY.**—C. Manlove, 1008 Walnut St., Kansas City, Mo.; 3d Friday in month, Kansas City.

**RAILWAY BUSINESS ASSOCIATION.**—Frank W. Noxon, 2 Rector St., New York. Annual dinner, second week in December, 1913, New York.

**RAILWAY CLUB OF PITTSBURGH.**—J. B. Anderson, Penna. R. R., Pittsburgh, Pa.; 4th Friday in month, except June, July and August, Pittsburgh.

**RAILWAY ELECTRICAL SUPPLY MANUFACTURERS' ASSOC.**—J. Scribner, 1021 Monadnock Block, Chicago. Meetings with Assoc. Ry. Elec. Engrs.

**RAILWAY FIRE PROTECTION ASSOCIATION.**—C. B. Edwards, Mobile & Ohio, Mobile, Ala. Next meeting, October 7, Chicago.

**RAILWAY GARDENING ASSOCIATION.**—J. S. Butterfield, Lee's Summit, Mo.

**RAILWAY DEVELOPMENT ASSOCIATION.**—W. Nicholson, Kansas City Southern, Kansas City, Mo.

**RAILWAY SIGNAL ASSOCIATION.**—C. C. Rosenberg, Bethlehem, Pa. Convention, October 14, Nashville, Tenn.

**RAILWAY STOREKEEPERS' ASSOCIATION.**—J. P. Murphy, Box C, Collinwood, Ohio.

**RAILWAY SUPPLY MANUFACTURERS' ASSOC.**—J. D. Conway, 2135 Oliver bldg., Pittsburgh, Pa. Meetings with M. M. and M. C. B. Assoc.

**RAILWAY TEL. & TEL. APPLIANCE ASSOC.**—W. E. Harkness, 284 Pearl St., New York. Meetings with Assoc. of Ry. Teleg. Sups.

**RICHMOND RAILROAD CLUB.**—F. O. Robinson, Richmond, Va.; 2d Monday except June, July and August.

**ROADMASTERS' AND MAINTENANCE OF WAY ASSOCIATION.**—L. C. Ryan, C. & N. W., Sterling, Ill.

**ST. LOUIS RAILWAY CLUB.**—B. W. Frauenthal, Union Station, St. Louis, Mo.; 2d Friday in month, except June, July and Aug., St. Louis.

**SIGNAL APPLIANCE ASSOCIATION.**—F. W. Edmonds, 3868 Park Ave., New York. Meeting with annual convention Railway Signal Association.

**SOCIETY OF RAILWAY FINANCIAL OFFICERS.**—C. Nyquist, La Salle St. Station, Chicago.

**SOUTHERN ASSOCIATION OF CAR SERVICE OFFICERS.**—E. W. Sandwich, A. & W. P. Ry., Montgomery, Ala. Annual meeting, October 16, 1913, Atlanta, Ga.

**SOUTHERN & SOUTHWESTERN RAILWAY CLUB.**—A. J. Merrill, Grant bldg., Atlanta, Ga.; 3d Thurs., Jan., March, May, July, Sept., Nov., Atlanta.

**TOLEDO TRANSPORTATION CLUB.**—J. G. Macomber, Woolson Spice Co., Toledo, Ohio; 1st Saturday, Toledo.

**TRACK SUPPLY ASSOCIATION.**—W. C. Kidd, Ramapo Iron Works, Hillsburn, N. Y. Meeting with Roadmasters' and Maintenance of Way Association.

**TRAFFIC CLUB OF CHICAGO.**—W. H. Wharton, La Salle Hotel, Chicago.

**TRAFFIC CLUB OF NEW YORK.**—C. A. Swope, 290 Broadway, New York; last Tuesday in month, except June, July and August, New York.

**TRAFFIC CLUB OF PITTSBURGH.**—D. L. Wells, Erie, Pittsburgh, Pa.; meetings monthly, Pittsburgh.

**TRAFFIC CLUB OF ST. LOUIS.**—A. F. Versen, Mercantile Library building, St. Louis, Mo. Annual meeting in November. Noonday meetings October to May.

**TRAIN DESPATCHERS' ASSOCIATION OF AMERICA.**—J. F. Mackie, 7122 Stewart Ave., Chicago. Next convention, June 16, Jacksonville, Fla.

**TRANSPORTATION CLUB OF BUFFALO.**—J. M. Sells, Buffalo; first Saturday after first Wednesday.

**TRANSPORTATION CLUB OF DETROIT.**—W. R. Hurley, L. S. & M. S., Detroit, Mich.; meetings monthly.

**TRAVELING ENGINEERS' ASSOCIATION.**—W. O. Thompson, N. Y. C. & H. R., East Buffalo, N. Y. Next meeting, Chicago.

**UTAH SOCIETY OF ENGINEERS.**—Fred D. Ulmer, Oregon Short Line, Salt Lake City, Utah; 3rd Friday of each month, except July and August.

**WESTERN CANADA RAILWAY CLUB.**—W. H. Rosevear, P. O. Box 1707, Winnipeg, Man.; 2d Monday, except June, July and August, Winnipeg.

**WESTERN RAILWAY CLUB.**—J. W. Taylor, Old Colony building, Chicago; 3d Tuesday of each month, except June, July and August.

**WESTERN SOCIETY OF ENGINEERS.**—J. H. Warder, 1735 Monadnock Block, Chicago; 1st Monday in month, except July and August, Chicago.

The State of South Dakota has complained before the Interstate Commerce Commission, of excessive rates for the transportation of coal from ports on Lakes Michigan and Superior to places in South Dakota.

A new route for through freight traffic will be opened on October 1, between eastern points and points in Arizona and California, via the El Paso & Southwestern system from Tucumcari, N. M., to Tucson, Ariz., in connection with the Rock Island lines on the east, and Southern Pacific on the west.

Mr. Prouty, of the Interstate Commerce Commission, held a hearing at Boston on Tuesday of this week on the application of the Boston & Maine for authority to make a general increase of 10 per cent. in its freight rates. Representatives of the Public Service Commissions of Maine, New Hampshire, Vermont and Massachusetts sat with Mr. Prouty.

The Lehigh Valley has opened a new freight pier at Jersey City, alongside its other piers near the Central of New Jersey passenger station. The new pier is 600 ft. long and replaces one which was destroyed by fire four years ago. This road has ordered for its New York harbor service a large tug, a car float to carry 23 cars, five lighters and five refrigerator barges.

J. C. Lincoln, traffic manager of the Merchants' Association, of New York City, has issued a statement showing in considerable detail the advantages accruing to New York shippers by reason of recent decisions of the Interstate Commerce Commission, making more favorable rates for the transportation of freight to places beyond the Mississippi river and to Duluth.

The monthly bulletin of the traffic department of the Chicago & North Western calls attention to the necessity for greater care on the part of agents and baggagemen to cancel tickets for baggage service by a baggage punch or special stamp when checking baggage on tickets. The bulletin states that in some cases passengers purchase tickets merely to get their baggage carried to destination, and travel themselves by automobile or electric line, and then send their railroad tickets in for redemption. It is unlawful for the company to redeem tickets without proper charge for service rendered.

The action of the railroads centering in Baltimore, Md., in abolishing free store-door delivery of freight, has been approved by the Interstate Commerce Commission; that is to say, the commission has refused to suspend the new tariffs, and they went into effect September 1, both at Baltimore and at Washington. It will be recalled that the subject of store-door delivery was considered at length by the commission in reporting on the practice at Washington some months ago, and that the commission decided that it must not be discontinued at Washington as long as it was continued at Baltimore. The merchants of Washington have now made formal complaint against the roads, declaring that rates from all directions are too high and asking that the carriers be ordered to make reparation on freight bills paid since the day when store-door delivery was abolished.

## Cars Worth More Than Demurrage Money.

M. W. Rotchford, manager of the Illinois & Iowa Demurrage Bureau, has issued a strong circular designed to promote car efficiency. Records of 45 principal lines within the territory of the bureau for the first seven months of 1913 show an increase in cars handled of 12.2 per cent. over the corresponding period of 1912, while the increase in cars earning demurrage is 61.15 per cent. The total demurrage earned this year, \$273,191, represents an increase of 68.16 per cent. This large increase in demurrage earnings and collections, the circular says, compared with the increase in cars handled "at first sight might be taken by some to indicate a favorable showing, but such is not the case when car efficiency is taken into consideration. The question that naturally arises is—then what does it indicate and what is the remedy? It means: 1, that cars are being delayed in loading and unloading to a greater extent; 2, that 24,673 more cars were withheld from transportation service by some patrons at the same time other patrons were wanting cars; 3,

REVENUES AND EXPENSES OF RAILWAYS.

MONTH OF JULY, 1913.

Name of road.	Average mileage operated during period.	Operating revenues			Operating expenses			Net operating revenue (or deficit).	Outside operations, net.	Taxes.	Operating income (or loss).	Increase (or decrease) comp. with last year.	
		Freight.	Passenger.	inc. misc.	Total.	Way and structures.	Maintenance of equipment.						Traffic.
Ann Arbor	292	\$106,260	\$58,621	\$177,823	\$22,749	\$57,866	\$4,818	\$60,064	\$67,688	\$120,185	\$13,930	\$43,251	\$791
Arizona & New Mexico	109	16,403	8,165	24,568	1,439	8,669	780	14,729	15,428	35,586	3,400	31,186	-17,293
Arizona Eastern	367	181,276	37,540	228,516	28,830	31,682	2,101	64,718	10,693	138,024	11,396	80,238	15,231
Archison, Topeka & Santa Fe	8,358	4,882,519	2,243,571	7,691,766	1,241,718	1,419,732	170,170	2,436,591	170,170	5,138,401	374,698	2,178,667	150,943
Atlanta & West Point	93	44,832	43,491	97,343	19,099	21,430	5,045	32,817	4,529	82,920	6,484	8,086	-4,606
Atlanta, Birmingham & Atlantic	645	177,302	64,275	261,966	41,944	49,790	14,639	105,864	10,798	223,035	14,336	24,595	26,731
Atlantic & St. Lawrence	167	70,550	32,623	103,173	39,015	19,015	3,763	59,072	3,428	114,327	10,157	12,711	-10,738
Atlantic Coast Line	4,617	1,588,101	684,400	2,457,152	417,281	457,801	47,138	987,465	81,139	1,989,824	132,000	335,328	63,262
Baltimore & Ohio—System	4,456	6,838,746	1,518,840	8,338,746	1,258,438	1,332,749	193,471	3,165,456	195,885	6,146,001	266,681	2,354,717	294,994
Baltimore & Ohio Chicago Terminal	21	.....	901	153,064	18,014	22,532	741	68,064	4,812	114,184	16,052	23,841	-2,085
Belt Ry. Co. of Chicago	77	.....	258,599	21,716	34,727	68,632	96,556	96,556	.....	162,543	9,270	86,286	-3,153
Bessemer & Lake Erie	204	1,034,107	46,220	1,092,177	94,441	146,661	12,612	227,254	10,623	491,591	38,000	562,826	-6,190
Birmingham Southern	43	70,001	1,208	118,791	16,440	14,075	53	36,588	4,080	71,717	1,805	45,269	20,641
Boston & Maine	2,252	2,341,530	1,615,877	4,279,434	566,687	660,803	34,567	1,864,985	112,822	3,219,874	165,220	918,753	-163,980
Buffalo & Susquehanna R. R.	253	139,766	9,391	153,124	28,687	22,428	1,266	30,229	6,263	109,073	2,200	18,794	-17,914
Buffalo & Susquehanna R. R.	91	41,052	12,566	56,811	9,870	27,422	455	21,304	2,497	61,548	1,600	6,459	3,489
Buffalo, Rochester & Pittsburgh	376	906,087	123,774	1,072,384	174,546	202,934	12,421	335,358	20,945	746,404	18,000	307,972	40,230
Butte, Anaconda & Pacific	90	198,365	14,081	212,885	13,007	19,823	679	41,487	4,303	79,299	2,250	40,036	29,888
Carolina, Clinchfield & Ohio	248	195,697	23,426	223,061	14,147	23,426	6,485	39,214	8,548	91,820	9,250	121,991	23,764
Carolina, Clinchfield & Ohio Ry. of S. C.	18	10,567	1,893	12,669	76	.....	1,285	2,429	320	4,623	750	7,694	2,663
Central of Georgia	1,924	581,530	342,976	1,005,290	155,369	240,277	37,110	372,519	38,496	843,771	50,370	118,529	-124,443
Central of New Jersey	676	1,690,720	628,704	2,398,398	261,977	374,804	30,708	720,492	45,666	1,433,647	94,888	956,840	-119,958
Central New England	277	228,065	35,338	276,704	32,197	42,493	1,116	73,843	6,932	156,581	10,500	109,953	34,502
Central Vermont	232	332,391	109,230	369,932	67,451	71,588	7,772	172,349	7,461	326,621	15,500	28,993	-24,951
Charleston & Western Carolina	341	107,983	32,382	146,460	29,738	27,304	3,107	57,229	4,320	121,698	5,000	19,762	13,901
Chesapeake & Ohio Lines	2,341	2,174,701	550,996	2,861,884	375,796	532,793	53,456	945,158	69,995	1,977,198	109,960	765,442	4,366
Chicago & Alton	1,032	842,899	398,804	1,328,289	172,055	348,503	38,503	481,133	34,976	975,313	39,000	311,166	-26,251
Chicago & Eastern Illinois	1,275	992,490	268,472	1,367,572	246,698	285,504	22,025	472,478	37,692	1,064,397	45,000	255,700	105,907
Chicago, Burlington & Quincy	9,129	4,955,629	2,126,229	7,754,559	1,114,005	1,421,568	131,397	2,874,971	90,773	5,145,188	304,275	2,886,895	282,514
Chicago Great Western	1,496	803,713	302,347	1,195,929	186,027	195,652	43,663	413,102	36,383	874,827	38,651	283,343	43,302
Chicago, Indiana & Southern	359	300,994	320,994	91,946	81,946	114,195	6,866	114,195	11,023	273,111	15,283	33,933	-8,042
Chicago, Indianapolis & Louisville	617	382,161	150,539	528,994	92,627	87,544	18,301	204,256	16,083	418,079	24,372	138,707	26,300
Chicago Junction	12	5,227,244	1,881,371	7,740,518	1,131,683	1,131,683	160,894	2,655,323	138,708	5,211,891	331,463	2,230,314	-163,329
Chicago, Milwaukee & St. Paul	255	93,506	32,640	133,633	22,104	28,770	6,633	58,507	5,003	121,019	4,800	7,814	1,914
Chicago, Rock Island & Gulf	477	156,022	58,633	234,023	41,889	61,774	10,203	91,273	8,013	188,897	7,935	35,580	-34,397
Chicago, St. Paul, Minneapolis & Omaha	1,747	828,784	481,457	1,310,241	276,386	386,164	27,008	519,736	32,461	1,050,433	71,700	302,067	12,619
Cincinnati, Hamilton & Dayton	1,015	620,707	157,876	882,593	131,419	141,752	20,560	409,909	18,353	733,993	34,112	114,988	-93,175
Cincinnati Northern	245	81,513	24,697	112,666	35,248	38,751	2,709	42,950	3,982	122,658	5,600	14,788	-33,173
Cleveland, Cincinnati, Chic. & St. Louis	2,014	1,927,122	804,469	3,002,283	582,727	776,604	74,217	1,288,519	71,571	2,795,698	103,860	106,482	-472,311
Colorado & Southern	1,131	519,149	160,088	715,787	107,174	172,808	13,017	199,580	21,542	514,121	20,666	168,735	39,561
Delaware, Lackawanna & Western	2,385	2,464,232	854,281	3,549,593	564,965	558,211	74,737	1,024,082	65,177	2,287,172	165,000	1,127,982	68,394
Denver & Rio Grande	2,583	1,399,061	66,000	2,044,611	499,178	396,086	44,392	386,626	54,083	1,580,365	87,800	382,679	-98,484
Detroit, Grand Haven & Milwaukee	191	113,000	.....	207,212	8,152	30,339	5,765	105,620	5,081	134,937	6,000	48,799	68,362
Detroit River Tunnel	2	.....	.....	108,228	3,191	3,009	.....	8,998	38	15,236	.....	86,992	12,062
Detroit, Toledo & Ironton	441	108,526	14,905	135,953	41,142	48,233	2,585	78,709	5,696	176,365	5,700	46,112	-64,447
Duluth, South Shore & Northern	356	1,224,876	323,838	1,627,467	120,310	99,766	2,014	195,333	10,352	427,775	73,594	772,221	136,013
Duluth, South Shore & Atlantic	627	177,691	110,607	311,927	75,535	36,127	8,573	111,469	8,486	240,190	18,000	55,739	-11,252
El Paso & Southwestern	982	70,663	103,342	701,974	122,073	104,670	15,770	199,099	27,451	469,063	35,000	196,271	-76,006
Elgin, Joliet & Eastern	801	1,026,050	.....	1,101,271	174,125	196,120	4,938	299,787	16,689	693,653	27,650	379,971	-186,300
Florence & Cripple Creek	76	82,318	30,046	114,330	9,566	17,143	2,655	30,044	3,984	63,392	1,933	49,005	1,126
Fort Worth & Denver City	454	364,566	156,103	411,742	62,598	87,323	10,924	147,027	14,489	322,975	12,400	75,225	-41,673
Galveston, Harrisburg & San Antonio	1,338	539,332	276,234	869,103	129,845	192,452	29,269	390,172	35,460	777,198	35,471	55,155	-85,672
Georgia	3,307	134,985	77,313	229,057	37,803	40,717	12,051	111,834	8,398	210,803	2,964	15,290	-859
Georgia, Southern & Florida	395	113,034	65,041	203,107	25,857	40,974	7,717	87,597	9,104	171,250	10,658	21,199	-2,177
Grand Rapids & Indiana	578	244,030	214,972	497,594	77,277	77,284	11,984	215,908	15,412	397,865	23,641	76,968	-16,003
Grand Trunk Western	347	364,000	226,500	632,194	62,448	115,027	20,261	266,701	14,765	479,577	31,500	119,250	27,586
Great Northern	7,750	5,463,431	1,580,055	7,515,727	1,262,924	1,771,097	118,142	1,750,732	116,441	4,019,336	408,245	3,124,241	745,878
Gulf, Colorado & Santa Fe	1,596	736,661	303,935	1,102,342	184,594	184,594	27,370	428,034	31,175	862,727	42,062	177,553	-54,087
Hocking Valley	352	559,613	84,985	704,015	82,815	143,101	2,014	210,167	13,926	459,323	41,000	203,692	-21,572
Houston, East & West Texas	191	60,072	38,821	104,513	23,229	16,166	2,003	38,534	4,210	84,142	3,690	16,681	-16,132
Houston & Texas Central	789	354,370	191,241	584,601	90,650	79,273	20,443	287,653	18,279	496,279	19,666	89,431	-40,103
Indiana Harbor Belt	105	506,490	203,082	729,272	274,147	151,202	2,623	127,816	7,463	215,868	5,000	54,667	-33,524
International & Great Northern	1,160	506,490	203,082	729,272	274,147	151,202	2,623	127,816	7,463	215,868	5,000	54,667	-33,524
International & Michigan	177	261,922	35,139	303,716	46,708	60,830	2,734	81,765	7,268	199,305	9,471	94,918	-18,697

REVENUES AND EXPENSES OF RAILWAYS.

MONTH OF JULY, 1913.—(CONTINUED).

Table with columns: Name of road, Average mileage operated during period, Operating revenues (Freight, Passenger, Inc. misc., Total), Maintenance of Way and equipment, Traffic, Transportation, General, Total, Net operating revenue (or deficit), Outside operations, net, Taxes, Operating income (or loss), Increase (or decr.) last year.



that railroads' cost of operation was increased by reason of extra switching caused by excessive detention. The remedy is: 1, education of the patron to the fact that the railroad prefers the cars to the demurrage charge; 2, an additional incentive to patron to return cars more promptly to transportation service; 3, increase the demurrage rate to \$3 per day, which, according to experience in California lessens car detention.

"There is an erroneous impression abroad that the railroads are satisfied when they collect the demurrage due. While it is incumbent upon the railroads to collect demurrage in accordance with their tariff and upon patrons to pay, the railroad loses about \$2 per car per day when it collects a dollar demurrage, as the average daily earning is about \$3 per car."

#### STATE COMMISSIONS.

The Montana Railroad Commission has ordered a general investigation of freight rates from all distributing centers in the state, to be begun at a hearing on October 8.

The Oklahoma Corporation Commission held a hearing recently on a proposed order requiring railways to stop passenger trains at the nearest station to the state line to afford interstate travellers an opportunity to repurchase tickets, thereby taking advantage of the two-cent state fare instead of the higher interstate rates.

The railroad committee of the East St. Louis Commercial Club appeared before the Illinois Railroad and Warehouse Commission last week, asking an order requiring better train service between East St. Louis and Chicago. Many of the fast St. Louis-Chicago trains cross the Mississippi river over the Merchants' bridge, thereby avoiding East St. Louis.

#### COURT NEWS.

The Court of Common Pleas at Erie, Pa., has refused to order the New York, Chicago & St. Louis to reduce passenger fares in Pennsylvania to two cents a mile. Attorneys for the road showed in their arguments, that Erie is the only important place on its line through the state with a few small towns to the east and west. It was shown that the road received only \$6,483 from these towns for the last year and that a two-cent fare would reduce this sum \$1,453. It was declared that trolley lines carry most of the local business.

Justice Lamar, of the Supreme Court of the United States, heard argument at Washington on Monday last on the application of the Louisville & Nashville for an order restraining the enforcement of the 2½ cent passenger fare order, which was recently issued by the State Railroad Commission of Alabama. The road offered to issue to each passenger with tickets, checks calling for a refund in case the suit to maintain a lower rate should fail; but its arguments proved fruitless and its application was denied. The road will now try to get the Federal court in Alabama to reconsider its decision.

**PROPOSED SPANISH RAILWAY.**—Proposals are requested for the concession and construction of a 280-mile railway from Torre del Mar to connect at Zurgena with the railway from Granada to Murcia, and to have branches from Guadal Feo to Granada, Lobras to Motril, and Tabernas to Almeria. The estimated cost is \$22,713,318. The rolling stock of this railway must comprise at least 36 locomotives; 24 first-class, 32 second-class, and 50 third-class passenger cars; 20 baggage cars; 150 box cars; and 250 other freight cars. The passenger cars are not to have side entrance doors. Plans are on file in the Ministerio de Fomento, Seccion de Ferrocarriles, Madrid, Spain, where they may be seen, and to which proposals accompanied by the provisional security must be submitted before February 27, 1914. Francisco Javier Cervantes is the petitioner for this railway and owner of its project and if successful in bidding against the petitioner, the concessionaire must refund the cost of making the project, which is \$45,611, plus the expenses of government examination of same, and 5 per cent. annual interest on these amounts combined from the date on which the project was filed. Work must be begun within three months from the date the concession is awarded and must be finished within seven years from the same date.

## Railway Officers.

#### Executive, Financial and Legal Officers.

E. Deschenes, Jr., has been appointed auditor of the Central Vermont, with office at St. Albans, Vt., succeeding W. G. Crabbe, deceased.

W. C. Everett has been appointed auditor of the Virginian Railway, with headquarters at Norfolk, Va., succeeding F. C. Uhlman, resigned to go to another company.

W. F. Bull, whose appointment as assistant secretary of the Southern Pacific Company, with headquarters at New York, has been announced in these columns, was born on February 10, 1874, at Newark, N. J. He began railway work in 1890, as a clerk on the Baltimore & Ohio, at Baltimore, Md., and in March, 1900, entered the service of the Southern Pacific as a clerk in the general office. He was later successively statistician in the vice-president's office, secretary of the pension department, chief clerk to the director of maintenance and operation, and at the time of his recent appointment as assistant secretary, was chief clerk to the chairman of the executive committee of the same road, with headquarters at New York.

#### Operating Officers.

William J. Melchior has been appointed assistant trainmaster of the Fargo division of the Northern Pacific, with headquarters at Dilworth, Minn.

William C. Francis has been appointed superintendent of dining service of the Illinois Central, with headquarters at Chicago, succeeding F. M. Dow, resigned.

G. W. Landon has been appointed an agent of the operating department of the Baltimore & Ohio Southwestern, with headquarters at North Bend, Ohio, succeeding H. A. Wedding.

C. C. Grimm has been appointed trainmaster of the Baltimore & Ohio at Newark, Ohio, in place of W. T. Eagan, resigned. C. W. Van Horn, trainmaster at Clarksburg, W. Va., has been transferred to Garrett, Ind., in a similar capacity. T. J. Rodgers has been appointed assistant trainmaster at Garrett.

J. J. Donnelly has been appointed trainmaster of the Gulf, Colorado & Santa Fe at Temple, Tex., succeeding E. E. Taylor, who has been transferred to Galveston, Tex., in a similar capacity in place of J. P. Cowley, who has been made trainmaster at Beaumont, Tex. W. M. Knowd has been appointed trainmaster at Temple.

D. B. Fleming, assistant superintendent of the New York Central & Hudson River at Albany, N. Y., has been appointed superintendent of the Buffalo division, with office at Buffalo, succeeding H. E. Brown, and F. S. Risley, trainmaster at Albany, has been appointed assistant superintendent of the Mohawk division, succeeding Mr. Fleming.

S. C. Wolfersberger, who has been appointed assistant superintendent of the Baltimore & Ohio, with headquarters at Somerset, Pa., was born at Broadford, Pa., and entered the service of the Baltimore & Ohio in June, 1882, as a warehouseman, later becoming yard clerk. In April, 1887, he was made locomotive fireman, and in March, 1892, was promoted to locomotive engineer, becoming road foreman of engines in October, 1901, of the same road. He was appointed trainmaster of the New Castle division in September, 1904, with headquarters at New Castle, Pa., later becoming supervisor of transportation of the Pittsburgh district, which position he held at the time of his recent appointment as assistant superintendent at Somerset, of the same road, as above noted.

Thomas W. McGaw, whose appointment as superintendent of the Savannah Terminal division of the Seaboard Air Line, with headquarters at Savannah, Ga., has been announced in these columns, was born on June 23, 1866, at Detroit, Mich., and was educated in the public schools of his native town. He began railway work in June, 1877, as a messenger boy on the Michigan Central. He was subsequently with the Wells Fargo Express consecutively as messenger, superintendent's clerk and agent, and with various western railroads as baggageman, brakeman, switchman and clerk, until 1890, when he went to the Union Stock

Yards at Chicago, as yardmaster, and later became manager of Swift & Company's railroad department. In 1897, he was appointed yardmaster of the Norfolk & Western at Lynchburg, Va., becoming general yardmaster at Norfolk in 1899. He went to the Seaboard Air Line as trainmaster in 1901, and two years later became assistant general yardmaster of the Illinois Central at New Orleans, La. From 1903 to 1905, he was trainmaster of the Illinois Central and the Yazoo & Mississippi Valley. He then became general yardmaster of the New York, Susquehanna & Western, remaining in that position until 1906, when he returned to the Seaboard Air Line as general yardmaster, and later was made trainmaster, which position he held at the time of his recent appointment as superintendent of the Savannah Terminal division of the same road as above noted.

Osmon L. Eaton, who has been appointed superintendent of the Baltimore & Ohio, with headquarters at Connellsville, Pa., as has already been announced in these columns, was born on June 28, 1863, at Pittsburgh, Pa.



O. L. Eaton.

He began railway work in 1880, with the Allegheny Valley, now a part of the Pennsylvania Railroad, and from November 1, 1881, to April 1, 1908, was consecutively operator, agent, train dispatcher, car distributor, chief train dispatcher, and assistant trainmaster at Pittsburgh, Pa., on the Baltimore & Ohio. In April, 1908, he was appointed trainmaster of the Connellsville division of the same road, and on March 1, 1912, became assistant superintendent of that division, with

headquarters at Somerset, Pa., which position he held at the time of his recent appointment as superintendent of the same road with headquarters at Connellsville, Pa., as above noted.

**Traffic Officers.**

A. J. Anderson has been appointed contracting freight agent of the Baltimore & Ohio at Chicago.

N. W. Secor has been appointed commercial agent of the Michigan Central at Toledo, Ohio, succeeding W. C. Thomas, transferred.

C. H. Jasper has been appointed district freight and passenger agent of the Southern Pacific at Fresno, Cal., succeeding J. F. Hixon, deceased.

F. B. Hillebrand has been appointed commercial agent of the Lehigh Valley, with office at Toledo, Ohio, succeeding H. T. Jenney, resigned.

Clarence P. Ware has been appointed soliciting freight agent of the Georgia Southern & Florida, with office at Cincinnati, Ohio, succeeding Chas. T. Dabney, resigned.

A. A. Robertson has been appointed general agent of the freight department of the Atchison, Topeka & Santa Fe at Cincinnati, Ohio, succeeding J. F. Thompson, transferred.

George W. Hamilton, chief clerk of the general freight department of the Union Pacific at Omaha, Neb., has been appointed assistant general freight agent at that place, to succeed Howard Bruner, who has been appointed chief clerk to B. L. Winchell, director of traffic, at Chicago.

Roy Terrell, assistant general freight and passenger agent of the Frisco lines in Louisiana and Texas, has been appointed general agent of the freight department of the New Orleans, Texas & Mexico lines, with headquarters at New Orleans, La., and Mark Anthony, has been appointed district passenger agent at that point. Mr. Anthony heretofore has been city passenger and ticket agent of the Frisco lines at New Orleans.

Alvin T. Steinel has been appointed general immigration agent of the Rock Island Lines, with headquarters at Chicago, succeeding C. B. Schmidt, who has been retired under the pension rules of the company. The agricultural and immigration departments have been consolidated and the title of commissioner of immigration, heretofore held by Mr. Schmidt, has been abolished, Mr. Steinel reporting to Prof. H. M. Cottrell, agricultural commissioner.

The following general agents will represent the Western Pacific, Denver & Rio Grande, Missouri Pacific and St. Louis, Iron Mountain & Southern at the points named: P. B. McAtee, Durango, Colo.; C. P. Ensign, Los Angeles, Cal.; J. Q. Patton, San Jose, Cal. The following are appointed general agents, passenger department, of the roads mentioned: T. F. Brosnahan, Fresno, Cal.; W. B. Townsend, Oakland, Cal.; J. C. Havelly, Sacramento, Cal.; R. V. Crowder, San Francisco, Cal.; I. A. Benton, Salt Lake City, Utah; W. H. Cundry, Colorado Springs, Colo.

**Engineering and Rolling Stock Officers.**

B. D. King has been appointed roadmaster of the Lake Erie & Western Eastern division, with office at Lima, Ohio, succeeding J. R. Coulston, resigned.

H. R. Warnock has been appointed superintendent of motive power of the Western Maryland, with office at Hagerstown, Md., succeeding C. M. Tritsch, resigned.

P. H. Hamilton has been appointed terminal roadmaster of the St. Louis & San Francisco, with headquarters at Memphis, Tenn., succeeding A. R. Van Zant, assigned to other duties.

W. F. Beardsley, master mechanic of the Pennsylvania Lines West of Pittsburgh, at Crestline, Ohio, was retired on September 1, under the pension rule of the company.

The position of master mechanic of the Missouri, Kansas & Texas, at Sedalia, Mo., heretofore held by G. P. Letts, is abolished and the duties of that office will be assumed by W. Rothmeyer, road foreman of engines at that place.

W. J. Fraudendiener, formerly superintendent of shops of the Lake Shore & Michigan Southern at Elkhart, Ind., has been appointed general inspector, locomotive department, in the office of superintendent of motive power, of the Cleveland, Cincinnati, Chicago & St. Louis at Indianapolis, Ind.

G. M. Crownover, whose appointment as superintendent of motive power of the Chicago Great Western, with headquarters at Oelwein, Iowa, has already been announced in these columns,

was born September 26, 1863, at McVeytown, Pa. He graduated from the high school at Hampton, Iowa, and began railway work April 1, 1881, with the Illinois Central at Waterloo, Iowa, as machinist apprentice. After serving an apprenticeship of four years he worked two years as journeyman machinist, and in April, 1887, was made roundhouse foreman at Clinton, Ill. He remained in that position for five years, when he was transferred to Waterloo as machine shop foreman, and in October, 1896, he was promoted to general foreman in charge of the Waterloo shops. In December, 1900, he was made division foreman at Fort Dodge, Iowa, and in April, 1902, again returned to Waterloo in charge of the new shops as general foreman. Mr. Crownover was made master mechanic at Freeport in November, 1902, and two years later was transferred to Chicago as shop superintendent in charge of the Burnside shops. He left the Illinois Central in December, 1909, to become master mechanic of the Chicago



G. M. Crownover.

December, 1900, he was made division foreman at Fort Dodge, Iowa, and in April, 1902, again returned to Waterloo in charge of the new shops as general foreman. Mr. Crownover was made master mechanic at Freeport in November, 1902, and two years later was transferred to Chicago as shop superintendent in charge of the Burnside shops. He left the Illinois Central in December, 1909, to become master mechanic of the Chicago

Great Western at Oelwein, Iowa, which position he held until September 1, when he was promoted to superintendent of motive power, as above noted.

I. S. Downing, whose appointment as master car builder of the Cleveland, Cincinnati, Chicago & St. Louis, with headquarters at Indianapolis, has been announced in these columns, was born at Bentonville, Ohio. He began railway work in April, 1886, as a car cleaner for the Flint & Pere Marquette, and from February, 1890, to February, 1892, was foreman of passenger work. He then went to the Lake Shore & Michigan Southern as a car cleaner at Toledo, Ohio, and from April, 1893, to March, 1895, was an inspector at Air Line Junction, Ohio. On the latter date he was made yard foreman at that point, and in November, 1899, was advanced to general foreman at the same place. Five years later Mr. Downing was appointed master car builder of that road at Englewood, Ill., and in August, 1906, he was transferred to Collinwood, Ohio, as master car builder. He held the latter position until September 1, when he became master car builder of the Cleveland, Cincinnati, Chicago & St. Louis, as above mentioned.



I. S. Downing.

#### Purchasing Officers.

R. W. Simpson has been appointed general fuel agent of the Intercolonial and the Prince Edward Island railways, with headquarters at Moncton, N. B.

#### Special Officers.

The operation of hotels and camps in Glacier National Park has been placed in the hands of the dining and sleeping car department of the Great Northern, and F. L. Hay, superintendent of that department, has been placed in charge, succeeding J. M. Cathcart.

#### OBITUARY.

William Armstrong Ingham, formerly president of the East Broad Top Railroad and Rock Hill Iron & Coal Co., died on September 23, at Philadelphia, Pa., at the age of 87. At the time of his death he was president of a number of industrial companies, also a member of the American Philosophical Society.

**NEW RAILWAY IN SOUTHERN INDIA.**—It is announced that a project has been submitted to the government of Mysore for constructing the 75-mile Mysore-Hassan railway from the city of Mysore, where it will connect with the Madras & Southern Mahratta Railway to the town of Hassan, which has no railway connection. The estimated cost of \$1,656,800 includes bridge construction. The three main bridges will span the Lakshmanathirtha, the Cauvery and the Hemavati rivers, and will cost \$97,300, \$48,650, and \$32,433, respectively. The country through which this railway will run is mostly flat, involving no steep gradients. The new line is destined to fill a long-felt need and gives promise of yielding good financial returns, as it will open up large and productive areas, such as the fertile Cauvery and Hemavati valleys, and will also tap important coffee and timber lands in the State of Mysore and the Province of Coorg. It is expected that active construction work on the new line will begin in the near future. In this connection it is of interest to note that in the State of Mysore there exists a marked predilection in favor of the employment of American materials and principles in construction work generally.

## Equipment and Supplies.

### LOCOMOTIVE BUILDING.

**THE WESTERN RAILWAY OF MINAS, BRAZIL**, has ordered 3 consolidation locomotives from the American Locomotive Company. The dimensions of the cylinders will be 13 in. x 16 in., the diameter of the driving wheels will be 33 in., and the total weight in working order will be 53,000 lbs.

**THE TOLEDO TERMINAL RAILWAY** has ordered two superheater consolidation locomotives from the American Locomotive Company. The dimensions of the cylinders will be 22 in. x 28 in., the diameter of the driving wheels will be 51 in., and the total weight in working order will be 198,000 lbs.

**CHICAGO JUNCTION RAILWAY** has ordered 1 superheater six-wheel switching locomotive from the American Locomotive Company. The dimensions of the cylinders will be 20 in. x 26 in., the diameter of the driving wheels will be 51 in., and the total weight in working order will be 149,000 lbs.

**THE NIGERIAN RAILWAYS OF AFRICA** have ordered 2 superheater mountain type locomotives from the American Locomotive Company. The dimensions of the cylinders will be 18 in. x 23 in., the diameter of the driving wheels will be 42¾ in., and the total weight in working order will be 140,000 lbs.

### CAR BUILDING.

**CHICAGO & NORTH WESTERN** is in the market for 1,000 gondola cars.

**THE PHILADELPHIA & READING** has ordered 50 passenger coaches from the Harlan & Hollingsworth Corporation.

**THE MAINE CENTRAL** has ordered 3 smoking cars, 2 coaches, 2 combination baggage and mail cars, 2 baggage cars and 2 postal cars.

**THE PENNSYLVANIA RAILROAD** is said to be in the market for 16 combination passenger and baggage cars. This item has not been confirmed.

**THE CHICAGO, BURLINGTON & QUINCY** has ordered 15 combination baggage and mail cars and 10 postal cars from the American Car & Foundry Company.

**THE NEW YORK CENTRAL LINES** have ordered 55 coaches and 31 mail cars from the Pressed Steel Car Company, 90 coaches and 45 baggage cars from the American Car & Foundry Company, 30 combination baggage and mail cars, 20 coaches and 8 dining cars from the Pullman Company, and about 100 passenger train cars from the Standard Steel Car Company.

### IRON AND STEEL.

**GENERAL CONDITIONS IN STEEL.**—It is estimated that the volume of business in rolled steel products in the last week has fallen off from 10 to 20 per cent. as compared with the orders booked during the first half of the current month. Consumers are inclined to be more conservative, anticipating lower prices because of the probable effect of the new tariff, but manufacturers point out that even if the tariff bill is enacted soon it will be several months, possibly six months, before the full effect of the measure can be determined. There is no doubt, however, that the large steel companies will protect their interests in the domestic market against foreign competition, as well as competing more actively for international trade.

### SIGNALING.

The Alabama Great Southern is to install automatic block signals between Moundville and Livingston, 46 miles, and in connection with this work will lay long passing tracks at Eutaw, Trustville, Montlake and High Point. With the completion of this work the road will have a stretch of 123 miles equipped with automatic block signals, namely, from Woodstock, Ala., to Meridian, Miss.

## Supply Trade News.

The Bryan & Texas Central is in the market for 2 gasoline passenger cars. W. E. Saunders, Bryan, Tex., is president.

Judge Carpenter, of the federal court at Chicago, has ordered the Central Trust Company, receiver, to ask bids for the sale of the Union Car & Equipment Company, West Pullman, Ill., which recently filed a petition in bankruptcy.

The Strauss Bascule Bridge Company, Chicago, has recently received orders for the following railroad bridges: One 105 ft., single leaf, double-track bridge with two 10 ft. wagon roads and two 6 ft. sidewalks over the Islais Creek channel at Kentucky street, San Francisco, Cal., for the Atchison, Topeka & Santa Fe and the Southern Pacific; one 90 ft., single-leaf, double-track bridge over the East Chicago canal, for the Baltimore & Ohio Chicago Terminal, and one 99 ft., single-leaf, single-track bridge over the Galena river at Galena, Ill., for the Illinois Central.

George H. Ross, formerly executive vice-president of the Chicago & Alton, Toledo, St. Louis & Western, Minneapolis & St. Louis and Iowa Central, and E. S. Wortham, who was formerly assistant to Mr. Ross and until recently manager of purchases and supplies of the Chicago & Alton, have formed a partnership for the handling of a general railway supply business under the name of the Ross-Wortham Company, in addition to representing the Scullin-Gallagher Iron & Steel Company of St. Louis, with offices at 418 McCormick building, Chicago. Mr. Ross is president of the company and Mr. Wortham vice-president.

"Made in Detroit," week during which the downtown merchants of Detroit, Mich., gave up their show windows to local manufacturers, was one of the most successful industrial exhibits ever held in Detroit, and will be made an annual feature. Among the exhibitors was the Detroit Lubricator Company, which exhibited among other devices a stand with three mechanical force feed oilers, pumping against a pressure of 200 lbs., and a duplicate of the big No. 72, eight-feed Bullseye locomotive lubricator used on the largest locomotive lubricator in the world—a superheater Mallet locomotive on the Virginian Railway.

Charles W. Allen, a vice-president and a director of the L. J. Bordo Company, Philadelphia, Pa., has been made manager of the railway department of the Reading-Bayonne Steel Castings Company, with office in Reading, Pa. Mr. Allen received his education in the Tamaqua schools and served an apprenticeship as machinist in the Tamaqua shops of the Philadelphia & Reading. After several years he was made engine house foreman at Milton, where he remained six years. In 1904 he was transferred to Reading as master mechanic of the Reading & Harrisburg division. He resigned this position on January 1, 1907, to become railroad representative of the L. J. Bordo Company. In 1908 he was made a vice-president and director of that company, which position he retained until his appointment as manager of the railway department of the Reading-Bayonne Steel Castings Company, as mentioned above.

### TRADE PUBLICATIONS.

**VALVES.**—Jenkins Bros., New York, have published an illustrated folder describing and pointing out the advantages of their various types of valves.

**NUTS AND BOLTS.**—The Kansas City Bolt & Nut Company, Kansas City, Mo., has published, in an illustrated booklet, a full list of its different products; dimensions and prices are included.

**UNDERGROUND RAILWAY FOR NAPLES.**—A British consular report states that a concession for an underground railway under Naples has been granted to a French syndicate.

**PROPOSED LINES FOR AUSTRALIA.**—A bill is to be introduced into the parliament of South Australia to provide for the construction of a line from Pinnaroo to Murrayville, a distance of about 15 miles, at an estimated cost of \$329,000, including \$25,000 for rolling stock, and a line about 18 miles long from Mount Gambier to Mumbannar, at an estimated cost of \$503,390.

## Railway Construction.

**ANTHONY & NORTHERN.**—An officer writes that the plans call for building from Pratt, Kan., north via Larned or via Great Bend, to Hastings, Neb., about 225 miles. The first section of six miles from Pratt north to Iuka has been completed. A contract has been given to Davis & Abermathy, for work on 21 miles, and additional contracts are to be let at once. The plans include building a steel bridge over the Arkansas river, also terminal buildings. O. P. Byers, president, Pratt, Kan. (August 8, p. 253.)

**BRYAN & TEXAS CENTRAL.**—An officer writes that this company was organized to build from Bryan, Tex., via Stone City to Wilcox. The company now has 15 miles in operation and ten miles additional have been graded. The work includes a steel bridge 297 ft. long over the Brazos river and a trestle over Little Brazos river. In addition to the use of steam motive power, gasoline motor cars are to be used on the line. The principal commodities to be carried are cotton, corn, merchandise, crushed rock, timber and wood. W. E. Saunders, president, C. B. Carson, chief engineer, and L. M. Hewit, traffic manager, Bryan.

**CAMDEN, SUMMERVILLE & GAULEY BRIDGE RAILROAD.**—Incorporated in West Virginia with \$50,000 capital, to build a railroad in Camden, Webster county, W. Va. The incorporators include J. J. Mead, Pittsburgh, Pa.; H. L. Kirtley, G. W. McClintick, W. G. Matthews and J. Carnes, Charleston, W. Va.

**CHICAGO & NORTH WESTERN.**—The report of this company for the year ended June 30, 1913, shows that an aggregate of 54 miles of yard tracks, sidings and industrial spurs were added during the year, and to provide for additional yard tracks, the company bought 60 acres of land adjoining the right of way near Waukegan, Ill., and about 186 acres near Kenosha, Wis. The Des Plaines Valley Railway, a double track outer belt line, from the Proviso yard on the Galena division to a point between Northfield and Blodgett, Ill., on the Wisconsin division, 20.51 miles, has been completed; the St. Louis, Peoria & Northwestern under construction from Peoria, Ill., to a point near Girard, 90.6 miles, is nearing completion. The Macoupin County Extension Railway was organized by the C. & N. W. in May, 1913, to build from a connection with the Macoupin County Railway near Benld, south about nine miles, to coal fields in Macoupin and Madison counties, Ill., and the Iowa Southern was organized in January, 1913, to build from a connection with the C. & N. W. in Monroe county, Iowa, southwesterly for about 25 miles, and construction work is now under way on about 13 miles.

**CLARKSBURG-NORTHERN.**—An officer of this company, which was organized to build from New Martinsville, W. Va., south to Middlebourne, thence southeast via Shirley, Center Point, Sedalia and Lynch, to Clarksburg, 63 miles, writes that track has been laid on six miles. A contract was given to J. T. Adams, Columbus, Ohio, last January, for the grading work, also to build the trestles and lay the tracks on 28 miles, to complete the line to Shirley. The work involves handling about 9,000 cu. yds. to the mile. Maximum grades will be 2 per cent., and maximum curvature 10 deg. The work has been suspended since March 1, owing to a controversy over the ownership, and it is understood that active construction work will not be under way until next spring. B. M. Robinson, president, New York, and H. M. Fry, chief engineer, 524 West Fourth street, Erie, Pa.

**FAIRMOUNT & VELEN.**—An officer writes that the company expects to have grading work finished by October 1, on the line now building from Velen, in Marshall county, S. Dak., east, thence north to Fairmount, N. Dak., 50.5 miles. Track has been laid on 30 miles. Brolander & Whittier, Northfield, Minn., have the grading contract. The work is light, and calls for the handling of about 8,000 cu. yds. to the mile. The principal commodities to be carried are grain and live stock. Julius Rosholt, president, Minneapolis, Minn., and J. H. Thomas, chief engineer, Fairmount, N. Dak. (May 2, p. 1013.)

**HOUSTON & TEXAS CENTRAL.**—An officer writes that work is now under way on a cut-off between Eureka, Tex., and Stella, about 10 miles, to cost about \$290,000. The line is being built to facilitate the handling of cotton and other through freight from north and central Texas points to Galveston, eliminating

the delay heretofore occasioned by handling through the Houston yards. About three miles of track has been laid and all the work is expected to be finished in about sixty days.

**HUDSON BAY RAILWAY.**—An officer writes that track has been laid on about 100 miles of the line now under construction from The Pas, Man., northeast to Port Nelson, 420 miles. J. D. McArthur, Winnipeg, Man., has the contract for building the line. The work involves handling about 1,500 cu. yds. of rock and about 15,000 cu. yds. of other materials to the mile. There will be a number of steel bridges with a total length of 2,600 ft. on the line, and at Port Nelson the terminals and harbor improvements will cost \$10,000,000. The company expects to develop a traffic in export wheat, agricultural products, imports, coal and steel products. J. Armstrong, chief engineer, Winnipeg, Man. (December 20, p. 1235.)

**ILLINOIS CENTRAL.**—The report of this company for the year ended June 30, 1913, shows that arrangements were made to raise the grades between Mounds and Cairo Junction, Ill. This work is now in progress and when completed will bring the track from Mounds south to the Ohio river approach above any probable high water. This company suffered severely from floods during March, which necessitated a great deal of replacement work. During the year, 105 new industrial tracks were added, with an aggregate length of 16.33 miles, and 107 new company sidings were added, the additional mileage being 27.38 miles. The remainder of the second main track between Ponchatlula and Orleans Junction, La., was completed and put in operation in November, 1912. Work was continued during the year on the grade crossing elimination work at Grand Crossing, Chicago.

**LORAIN, ASHLAND & SOUTHERN.**—An officer of this company, which operates a line from Custaloga, Ohio, northwest to Ashland, 21.2 miles, writes that the company expects to have the work finished by January 1, 1914, on the extension from Ashland, north via Wellington and Oberlin to Lorain. McArthur Brothers Company is carrying out the grading work, and about 22 miles of track has been laid. The heaviest cut requires the handling of about 54,000 cu. yds., and the average cost a mile for the construction is \$35,000. The company will use electricity as the motive power for passenger service, and steam as the motive power for freight service.

**LEXINGTON & EASTERN.**—See Louisville & Nashville.

**LOUISVILLE & NASHVILLE.**—According to press reports a contract has been given to the Adams & Sullivan Construction Company for building the extension of the Lexington & Eastern up Rock House creek in Letcher and Knott counties, Ky. (July 4, p. 36.)

**NEW YORK SUBWAYS.**—The New York Public Service Commission, First district, has executed two agreements with the New York Municipal Railway Corporation (Brooklyn Rapid Transit) for important modifications of the Dual System subway contracts, by which the construction and operation of two important links in the Brooklyn system will be expedited. One agreement covers the construction of the Thirty-eighth street line, in the borough of Brooklyn, from Fourth avenue to Tenth avenue, to be part subway and part open cut, and which will connect the Fourth avenue subway with the new elevated roads to be built over the routes of the Culver Line and the new Utrecht avenue line to Coney Island. The other agreement covers the remaining construction work in the Centre street subway loop, in the borough of Manhattan, already under partial operation by the elevated trains of the Brooklyn company. At present only the two westerly tracks in this subway are being operated. Under the new agreement the other two tracks will be equipped for use, certain cross-overs will be constructed, the Essex street station on the Williamsburg bridge will be reconstructed and the station at Chambers street, underneath the Municipal building, altered so as to permit the entrance of the track connection with the Brooklyn bridge now under construction. The Brooklyn company agrees to have the work under both agreements completed within 18 months.

The form of contract for section No. 3, of the Seventh avenue subway, in the Borough of Manhattan, to be operated by the Interborough Rapid Transit Company, has been completed by the Public Service Commission, First district, and submitted to the railway company for approval. This subway will be a four-track line running from Times Square south through Seventh

avenue, Varick street, and other streets, to the Battery and to Brooklyn. Section No. 3 begins at a point under Varick street, about 100 ft. south of the southerly building line of Beach street, and runs northerly under Varick street and Seventh avenue extension to a point opposite the southerly building line of Commerce street. This section of the subway will be a four-track line. The Interborough company is to return the contract to the commission within ten days, after which it will be adopted and advertised for bidders. Bids are to be opened on October 1, for section No. 2, which is immediately south of this section. (September 19, p. 541.)

**NORFOLK SOUTHERN.**—An officer writes regarding the extension of the Raleigh, Charlotte & Southern from Mt. Gilead, N. C., west to Charlotte, 53 miles, that the entire line has been graded and track laying finished except on a 14-mile section. There are two steel viaducts not yet completed on this section, one over Big Long creek, about seven miles west of Norwood, and the other over Rocky river, 14 miles west of Big Long creek. It is expected that the bridges will be completed about the middle of October, and all the track will be laid, so that trains can be operated into Charlotte by November. (July 11, p. 77.)

**RALEIGH, CHARLOTTE & SOUTHERN.**—See Norfolk Southern.

**ST. JOHN & QUEBEC.**—An officer writes that contracts are to be let this autumn to build an 80-mile section of the 210-mile line between St. John, N. B., and Grand Falls, of which 120 miles are already under construction. The contractors now at work include Cobett & Sons, and the Hibbard Company, Ltd., of Fredericton, N. B., and Kennedy & McDonald, of Woodstock. Track has been laid on 40 miles. The grading work involves handling about 20,000 cu. yds. a mile. The line will have 1 per cent. grades north of Fredericton and south of that place .4 per cent. grades southbound, and 6 per cent. grades northbound. The maximum curvature will be 7 degrees. There will be one steel bridge to have a total length of about 1,950 ft. On completion the line is to be operated by the Intercolonial Railway. A. R. Gould, president, Presque Isle, Maine. R. Thompson, chief engineer, Fredericton, N. B. (August 29, p. 396.)

**SAN LUIS CENTRAL.**—This road was recently opened for business, it is said, from Monte Vista, Colo., north to Center, 14 miles. J. B. Cosgriff is president; T. A. Cosgriff, vice president; George McLean, treasurer; and A. T. Young, general manager, all of Denver.

## RAILWAY STRUCTURES.

**BUFFALO, N. Y.**—The Lehigh Valley has started preparatory work towards the construction of a new passenger station on Main street, in Buffalo. Before construction work on the terminal can be begun, important changes must be made in the passenger yards. New approaches to viaducts must be built and the tracks moved over into the bed of the old Hamburg canal strip, which the railroad has secured; and a number of grade crossings are to be eliminated. The work is being done by the Eastern Concrete Steel Construction Company, and will be pushed to completion.

**CHICAGO.**—The report of the Chicago & North Western for the year ended June 30, 1913, shows that work was carried out during the year as follows: At Chicago a brick power house, 38 ft. x 85 ft., was constructed, and the engine house enlarged; at the Chicago shops a modern hot water boiler wash-out system was installed in a new building, and a building 40 ft. x 176 ft. was also built. At West Chicago a modern brick passenger station was completed and important additions and alterations were made in yard and track facilities. The building formerly used as a passenger station has been removed to a new location for use as a freight house. An overhead highway bridge connecting Parker avenue and Depot street was built, and work is now under way on an overhead highway bridge extending Maple avenue across the C. & N. W. tracks. An overhead bridge about 3,000 ft. long, including approaches, was built at the Wolf road crossing, Proviso, Ill., to permit highway traffic to pass over the C. & N. W. freight terminal yards. At Clinton, Iowa, work is under way on a 9-stall engine machine shop, an 8-stall engine machine shop,

power house, store and office building, and an engineers' and firemen's building, which it is expected will be completed during 1913, and a 425 ft. extension has been built to the company's ice house. At Council Bluffs a brick freight house, 40 ft. x 258 ft.; a brick office building 33 ft. x 35 ft.; also a boiler house, machinery and transfer platforms and track changes have been completed. At Omaha, Neb., the C. & N. W., has jointly with the Chicago, St. Paul, Minneapolis & Omaha, built a 15-stall brick engine house, a machine shop, 50 ft. x 140 ft., an oil house, and installed an 80-ft. turntable. At Milwaukee, Wis., a two-story brick freight house, 50 ft. x 360 ft. was built, and at Green Bay, a 40-stall brick engine house, power house, store and oil house, cinder pit, turntable, coal and water station and ice house, including necessary trackage, are under construction. At Ashland, Wis., ore dock No. 1, has been partially rebuilt and its total capacity greatly increased. Modern brick passenger stations were also completed during the year at Evansville, Wis., and at Waseca, Minn.

**PANA, ILL.**—The report of the Illinois Central for the year ended June 30, 1913, shows that during the year this company built new passenger stations at Pana, Paxton, Boos, Oglesby, Matlock, Iowa, and at Mayfield, Ky., and new freight houses were put up at Cairo, Ill., Manchester, Iowa, and Jackson, Miss. The station buildings were enlarged at Christopher, Ill., Waterloo, Iowa, White Plains, Ky., Hazlehurst, Miss., Belmont and Holcut. The work of constructing a new passenger station at Memphis, Tenn., to be used jointly with the St. Louis & San Francisco and the Chicago, Rock Island & Pacific, was started during the year, and elevation of the tracks from Broadway to Huling avenue, Memphis, is also in progress. New mechanical coaling plants were erected at Springfield, Ill., and at Hammond, La. In connection with the classification yard at Centralia, Ill., a new mechanical terminal consisting of a 48-stall roundhouse, machine, boiler and blacksmith shop, together with power house, storehouse, coaling station, wood mill, car repair shed and shops, and two water tanks, were also constructed, and the work of installing a new mechanical plant at Nonconah, Tenn., has recently been started and is now under way. During the year 4,061 lineal feet of permanent bridges and trestles were constructed, replacing timber and pile bridges, trestles and embankments; 2,133 lineal feet of permanent bridges and trestles were rebuilt or replaced by embankment, and 10,411 lineal feet of timber and pile bridges and trestles were rebuilt or replaced by embankment.

**PORT NELSON, MAN.**—See Hudson Bay Railway under Railway Construction.

**NEW LOCOMOTIVES FOR INDIAN LINE.**—Sanction has been accorded to the addition of 10 passenger engines to the motive power of the 5 ft. 6 in. gage system of the Bombay, Baroda & Central India Railway during 1914.

**NEW LINE FOR AUSTRALIA.**—The bill for the construction of a railway from Condobolin to Broken Hill has been passed by the Legislative Council of New South Wales. The line will be 372 miles long, and is to be laid with 80 lb. rails, the total cost being estimated at \$6,500,000. Steam motive power is to be used. This new line will shorten by 24 hours the journey between Adelaide and Sydney, and will also form a link in a transcontinental line from Western Australia to Queensland.

**PROPOSED RAILWAY UP BEN NEVIS, SCOTLAND.**—Wide interest is being taken in the proposition of building a tourist hotel on the summit of Ben Nevis, Scotland's highest mountain. The hotel will occupy the site of the former Meteorological Observatory, and when completed will be reached by a railway five miles long, the construction of which is estimated to cost about \$150,000. In ordinary seasons, Ben Nevis is climbed by fully 15,000 people. Assuming that one-half of the tourists, taking that number as a basis, patronize the railway, the promoters expect to realize an annual income of about \$10,650 on proposed charge of 24 cents for single and 36 cents for return fare. Should the project materialize as expected, visitors can travel by rail to the highest altitude in the British Isles and sojourn in comfort for a brief period. The Duke of Montrose and other influential men are promoters of the undertaking, and the consulting engineers are Stevenson & McGuffie, Hope street, Glasgow.

## Railway Financial News.

**BALTIMORE & OHIO.**—See an item in regard to this company under General News.

Kuhn, Loeb & Co. and Speyer & Co., both of New York, bought from the company and sold to the public \$10,000,000 4½ per cent. equipment trust certificates of April 1, 1913, maturing \$1,000,000 annually beginning April 1, 1914. The certificates were offered to the public at a price yielding 5¼ per cent. interest on the investment.

John P. Green and Joseph Wood, both representing Pennsylvania interests, have resigned from the board of directors of the Baltimore & Ohio.

**FITCHBURG.**—Stockholders voted on September 24 to approve the issue of \$2,100,000 bonds, of the proceeds of the sale of which \$500,000 is for refunding and the remainder for additions and betterments.

**FORT DODGE, DES MOINES & SOUTHERN.**—Judge McPherson has set the date for the foreclosure sale of this property for November 29. The upset price is \$2,676,000. The road will be sold in parcels, the main line running from Des Moines to Rockwell City forming one parcel; the road from Colfax to Newton another, and the road from Des Moines Junction to Goddard another.

**NEW YORK, NEW HAVEN & HARTFORD.**—Dr. Arthur T. Hadley, president of Yale University, and James H. Hustis have been elected directors, succeeding D. H. Warner and S. W. Winslow. See editorial comment in regard to the election of Dr. Hadley.

**ST. LOUIS & SAN FRANCISCO.**—B. F. Yoakum is quoted in the *Wall Street Journal* as follows, in regard to the separation of the Frisco and the New Orleans, Texas & Mexico:

"An adjustment of the relation between the 'Frisco and the New Orleans, Texas & Mexico will, I am confident, be reached at an early date.

"The 'Frisco is a western property and as such all matters pertaining to its future and all controversies between the different interests will be adjusted in the West.

"Under the laws of the State of Missouri under which 'Frisco holds its charter and in compliance with the laws of other states which these lines serve it may be difficult to get an amicable settlement of all the differences. It took about fifteen years to get these properties together, but adjustments, once they get started, will rehabilitate these properties quickly.

"All such matters, however, can be best handled in the states where the lines are located and in compliance with the laws of the various states which these lines serve. Most of these states have radically changed their laws since the properties constituting the 5,200 miles of the 'Frisco system were merged. Therefore in the rehabilitation of the 'Frisco the changed laws of the several states must necessarily be taken into consideration."

**TONOPAH & GOLDFIELD.**—A dividend of 3½ per cent. has been declared on the common stock and 7 per cent. on the preferred stock. Last year a total of 7 per cent. was paid on the common and 7 per cent. on the preferred.

**UNION PACIFIC.**—At the executive meeting on September 23 only routine business was discussed. A director is quoted as saying: "Not only is the time for declaring an extra distribution altogether unsettled, but the manner and the very fact that there shall or shall not be such a distribution are as yet entirely undetermined."

**WILLIAMSVILLE, GREENVILLE & ST. LOUIS.**—R. E. Slowey, of Greenville, Mo., has been appointed receiver.

**MACHINE SHOP FOR CHILEAN GOVERNMENT RAILWAYS.**—A machine shop, to cost \$47,014, is being constructed for the Chilean Government Railways at Temuco.

**RE-OPENING THE NEAR EAST RAILWAYS.**—The Servian government having declared its readiness to restore railway communication, two trains are now running daily between Sofia and Belgrade.

# ANNUAL REPORTS.

## ILLINOIS CENTRAL RAILROAD COMPANY.

### REPORT OF THE BOARD OF DIRECTORS.

To the Stockholders of the Illinois Central Railroad Company:  
 The Board of Directors herewith submit the following report of the operations and affairs of your Company for the year ended June 30th, 1913: The number of miles of road operated on June 30th, 1912, was 4,762.70. There was no change in the road mileage during the year and in consequence the number of miles of railroad operated on June 30th, 1913, as well as the average number of miles operated during the year, was 4,762.70.

#### INCOME.

The following Income Account for the year is stated in accordance with the classification of the new form of Income Account promulgated by the Interstate Commerce Commission, effective July 1, 1912, and the account of the preceding year has been re-stated for purposes of comparison, the amounts accrued on the Company's holdings of securities of its own issue being eliminated from "Other Income" and from "Deductions from Gross Income."

	1913.	1912.	INCREASE + DECREASE -
Average miles operated during year	4,762.70	4,762.70	.....
Railway operating revenues:			
Freight	\$42,589,298.68	\$37,881,765.94	+\$4,707,532.74
Bridge tolls and miscellaneous freight	3,371,419.24	2,798,905.54	+ 572,513.70
Passenger	13,455,884.45	13,337,562.40	+ 118,322.05
Bridge tolls and miscellaneous passenger	248,202.36	264,728.59	- 16,526.23
Mail	987,249.52	962,848.30	+ 24,401.22
Express	1,788,530.02	1,851,584.23	- 63,054.21
Other passenger train	528,874.50	418,748.17	+ 110,126.33
Other transportation	778,173.47	769,023.37	+ 9,150.10
Revenue from operations other than transportation	533,270.78	442,105.63	+ 91,165.15
<b>Total railway operating revenues</b>	<b>64,280,903.02</b>	<b>58,727,272.17</b>	<b>+ 5,553,630.85</b>
Railway operating expenses:			
Maintenance of way and structures	8,519,024.94	7,691,214.55	+ 827,810.39
Maintenance of equipment	13,952,654.02	13,857,548.66	+ 95,105.36
Traffic expenses	1,320,583.43	1,400,941.84	- 80,358.41
Transportation expenses	24,743,324.38	23,653,249.18	+ 1,090,075.20
General expenses	1,513,324.80	1,518,512.31	- 5,187.51
<b>Total railway operating expenses</b>	<b>50,048,911.57</b>	<b>48,121,466.54</b>	<b>+ 1,927,445.03</b>
<b>Net revenue—rail operations</b>	<b>14,231,991.45</b>	<b>10,605,805.63</b>	<b>+ 3,626,185.82</b>
Outside operations:			
Revenues	505,511.58	493,378.32	+ 12,133.26
Expenses	583,103.98	600,735.22	- 17,631.24
<b>Net deficit—outside operations</b>	<b>77,592.40</b>	<b>107,356.90</b>	<b>- 29,764.50</b>
<b>Net railway operating revenue</b>	<b>14,154,399.05</b>	<b>10,498,448.73</b>	<b>+ 3,655,950.32</b>
Railway tax accruals	2,903,550.98	2,685,730.13	+ 217,820.85
<b>Railway operating income</b>	<b>11,250,848.07</b>	<b>7,812,718.60</b>	<b>+ 3,438,129.47</b>
Other income	5,999,351.71	4,370,759.66	+ 1,628,592.05
<b>Gross income</b>	<b>17,250,199.78</b>	<b>12,183,478.26</b>	<b>+ 5,066,721.52</b>
Deductions from gross income	10,675,086.91	8,717,030.39	+ 1,958,056.52
<b>Net income</b>	<b>6,575,112.87</b>	<b>3,466,447.87</b>	<b>+ 3,108,665.00</b>
Disposition of net income:			
Appropriated for additions and betterments		61,481.44	- 61,481.44
Balance transferred to credit of profit and loss	6,575,112.87	3,404,966.43	+ 3,170,146.44

#### REVENUES.

While it was expected that the business for the current year would show a material increase as compared with the preceding year owing to the many disturbing factors which occurred in that period, it is gratifying to report that the operating revenues for the current year were \$64,280,903.02 compared with \$58,727,272.17 for the preceding year, an increase of \$5,553,630.85, or 9.46 per cent, and that, notwithstanding the fact that the Company was handicapped by the flood conditions in the southern states which entirely stopped the movement of traffic between the northern and southern lines for a period of nine days, the revenue from the transportation of freight and the revenue from the transportation of passengers were the largest in the history of your Company, the freight revenue being \$1,085,313.45, and the passenger revenue \$118,322.05, greater than in any prior year.

Compared with the previous fiscal year, the revenue from the transportation of freight increased \$4,707,532.74, or 12.43 per cent, and the increase was general over the northern, southern and western lines. The tons of revenue freight carried were 30,447,165 compared with 26,339,149 tons. The principal commodities transported, as well as a comparison of the tonnage of such commodities with the previous year, are shown on Table No. 13.

Revenue from the transportation of passengers increased \$118,322.05, or .89 per cent compared with the previous year. The passenger revenue on the northern and western lines showed a satisfactory increase; but there was a decrease on the southern lines.

The general details of the freight and passenger traffic are shown in Table No. 12.

#### EXPENSES.

The operating expenses increased \$1,927,445.03, or 4.01 per cent, being \$50,048,911.57 compared with \$48,121,466.54 for the preceding year.

#### MAINTENANCE OF WAY AND STRUCTURES.

Maintenance of way and structures expenses increased \$827,810.39, or 10.76 per cent. There was a large increase in expenditures on roadbed and bridges occasioned by the damage caused by the floods in the spring months and by the general use of heavier equipment on all main lines. There were also substantial charges to operating expenses in connection with the erection of a new mechanical plant at Centralia, Illinois, and other important additions and betterments, as well as large charges on account of a greater number of cross-ties placed in the track and a greater number of miles of rail laid replacing rail of lighter weight.

The following important renewals were made, the entire cost of which was charged to operating expenses:

2,218,420 cross-ties were renewed, being equivalent to 739.49 miles of continuous track, or 11.2 per cent of all ties in track including sidings.

There were 7.25 miles of track relaid with new steel rail and 1.59 miles with second-hand rail replacing rail of the same weight.

5,871 lineal feet of timber and pile bridges were rebuilt or replaced by embankments.

1,010 lineal feet of iron pipe culverts and 3,308 lineal feet of concrete pipe culverts were put in.

565 miles of ballasted track were repaired or renewed to restore to original standard.

Information is given under the head of "Physical Changes" on page 10 of this report as to work charged wholly to "Additions and Betterments" as well as work charged partly to "Additions and Betterments" and partly to "Renewals."

#### MAINTENANCE OF EQUIPMENT.

There was an increase in maintenance of equipment expenses of \$95,105.36, or .69 per cent.

Charges for depreciation of equipment amounted to \$1,560,730.56, compared with \$1,576,957.82 for the preceding year, a decrease of \$16,227.26.

Owing to the strike of shop employes on September 30th, 1911, of which mention was made in the annual report of last year, it was necessary to secure practically a new force of shopmen on all of your Company's lines, and until these employes became accustomed to their new surroundings and conditions, they were unable to perform the same amount of work which had previously been turned out by a corresponding number of the employes who had left the service. However, the new men have rapidly increased in efficiency with the result that during the last few months of this fiscal year we have not only been able to keep up our current repairs, but have made material strides in taking care of such work as had accumulated. As considerable work was deferred during the previous year, a comparison of the important work performed this year is made with the year ending June 30th, 1911.

358 locomotives received general repairs compared with 340 for the year 1911, and 323 received thorough repairs compared with 335 for the year 1911.

57,963 freight cars received medium repairs compared with 54,466 for the year 1911, and 31,060 received heavy repairs compared with 30,435 for the year 1911.

453 passenger train cars received general repairs compared with 371 for the year 1911, and 151 received thorough repairs compared with 124 for the year 1911.

The average mileage per serviceable locomotive for the year was 30,976. The average age of locomotives was 12.77 years compared with 13.98 years for the preceding year, of revenue freight cars 10.19 compared with 9.86 years for the preceding year, and of passenger train cars 17.8 years compared with 19.1 years for the preceding year.

#### TRAFFIC EXPENSES.

There was a decrease in traffic expenses of \$80,358.41, or 5.74 per cent. A general agency was established at Portland, Oregon.

#### TRANSPORTATION EXPENSES.

Transportation expenses increased \$1,090,075.20, or 4.61 per cent. The increase is in large part accounted for by the increased business handled, the tons of all freight carried one mile having increased 17.44 per cent, and the revenue passenger carried one mile .25 per cent. There was also a substantial portion of the increase chargeable to the congestion of traffic following the flood conditions in the South, to the increased price per ton paid for fuel, to the settlement of a number of large personal injury claims sustained in previous years which have been in litigation, and to the constantly growing loss and damage claims.

#### GENERAL EXPENSES.

There was a decrease in general expenses of \$5,187.51, or .34 per cent.

#### TAXES.

Taxes increased \$217,820.85, or 8.11 per cent. There was a substantial increase in the Charter Tax in Illinois owing to the greatly increased gross revenue on our Charter Lines. There were also increases in taxes in the States of Iowa and Mississippi and in the State of Illinois on properties other than the Charter Line.

#### FINANCIAL.

The financial condition of the Company at the close of the fiscal year compared with the previous fiscal year is shown in the general balance sheet, Table No. 4.

#### CAPITAL STOCK AND FUNDED DEBT.

There was no change in the capital stock during the year. During the month of July, 1912, \$15,000,000 Four and One-Half Per Cent Secured Gold Notes due July 1st, 1914, were issued and sold.

\$1,000,000 Refunding Mortgage Four Per Cent Gold Bonds of 1955 were issued and sold in January, 1913.

\$8,000,000 Illinois Central Equipment Trust, Series "A," certificates were issued and sold during the month of February, 1913.

In accordance with the terms of the indenture, \$2,000,000 First Lien Equipment Bonds were delivered to the trustee and cancelled.

SECURITIES OWNED.

The First, Second and Third Preference Income Bonds of the Central of Georgia Railway Company purchased during the preceding fiscal year were sold to that company, and \$15,000,000 of Central of Georgia Railway Company's six per cent Cumulative Preferred Stock was purchased at par. The stock purchased was pledged as part security for your Company's four and one-half per cent Secured Gold Notes due July 1st, 1914.

The Company also purchased the following securities: \$240,000 par value of the capital stock of the Belt Railway Company of Chicago; \$520,000 par value of the common stock and \$150,000 par value of the preferred stock of the Chicago, Memphis & Gulf Railroad Company.

\$444,220.75 of bonds and scrip of The Yazoo & Mississippi Valley Railroad Company's Gold Improvement Fours of 1934, were received in payment for amounts advanced by your Company for construction.

\$12,500 par value of Peoria & Pekin Union Railway Company's five per cent Debenture Bonds matured August 1st, 1912, and were redeemed by that company.

\$1,000,000 par value of Louisville Division and Terminal three and a half per cent Bonds of 1953, held in the treasury were sold during February and March, 1913.

\$40,000 par value of preferred stock and \$40,000 par value of common stock of the Chicago Union Transfer Railway Company were sold.

INSURANCE AND OTHER FUNDS.

The Insurance Fund was augmented during the year by charges to operating expenses; and other charges have been made as follows:

	Year Ending June 30, 1913.	Year Ending June 30, 1912.
Amount at credit of fund July 1st.....	\$2,086,259.39	\$2,067,701.58
Added through monthly charges to operating expenses.....	60,000.00	60,000.00
Collected from lessees account of insurance...	3,417.18	4,059.37
Interest received on investments of the fund...	84,300.00	83,100.00
Fire losses collected.....	13,670.74	23,198.63
	\$2,247,647.31	\$2,238,059.58
Losses by fire.....	\$ 110,234.11	\$ 107,102.41
Premiums paid for reinsurance.....	47,568.66	44,697.78
	\$ 157,802.77	\$ 151,800.19

Amount at credit of fund June 30th..... \$2,089,844.54 \$2,086,259.39  
 The various sinking funds as of June 30, 1913, are as follows:  
 Cairo Bridge Contingent Fund, \$504,180.00.  
 Cairo Bridge Sinking Fund, \$281,552.63, an increase of \$29,886.27.  
 Sinking Fund for Western Lines Bonds, \$1,222,634.27, an increase of \$93,153.60.  
 Sinking Fund for Omaha Division Bonds, \$159,796.44, an increase of \$15,955.00.  
 The additions during the year to the several sinking funds amounted to \$138,994.87.

ADDITIONS AND BETTERMENTS.

There was expended during the year for Additions and Betterments (including improvements on subsidiary properties) \$10,119,157.82. The following is a classified statement of these expenditures:

	ADDITIONS AND BETTERMENTS PAID FOR FROM PROCEEDS OF GENERAL REFUNDING MORTGAGE BONDS.	ADDITIONS AND BETTERMENTS APPROPRIATED OUT OF PROFIT AND LOSS.	ADDITIONS AND BETTERMENTS REPRESENTED BY ADVANCES TO SUBSIDIARY LINES.
Right of way and station grounds.....	\$ 102,927.97	\$ 122,481.38	Cr.\$ 297.90
Real estate.....	34,279.40	Cr. 37,046.55	Cr. 18,830.56
Widening cuts and fills.....	900.00		22,953.96
Protection of banks and drainage	2,135.46		28,552.05
Grade reductions and changes of line.....	682.67		2,583.50
Bridges, trestles and culverts.....	148,156.10	61,191.34	239,203.20
Increased weight of rail.....	29,932.03	18,118.16	94,637.36
Improved frogs and switches.....	1,166.22		669.38
Track fastenings and appurtenances	99,772.32	5,700.71	145,144.21
Ballast.....			57,703.94
Additional main tracks.....	72,066.22	16.34	195,601.34
Sidings and spur tracks.....	235,503.33	5,583.69	153,314.98
Terminal yards.....	341,384.70		32,242.20
Fencing right of way.....	382.19		2,106.61
Improvement of crossings under or over grade.....	16,530.35		
Elimination of grade crossings...	116,597.61		38,625.60
Interlocking apparatus.....	48,673.49		10,985.51
Block and other signal apparatus.	406,073.37		10,867.65
Telegraph and telephone lines....	31,674.99		2,280.34
Station buildings and fixtures....	103,935.04	90,050.59	99,976.02
Roadway machinery and tools.....	2,040.55		811.86
Shops, enginehouses and turntables	535,020.03		65,485.99
Shop machinery and tools.....	129,204.88		48,309.59
Water and fuel stations.....	53,853.22		21,929.79
Grain elevators and storage warehouses.....			3,294.77
Dock and wharf property.....			469.54
Electric light and power plants....	93.55		694.19
Electric power transmission.....	13,079.81		2,484.65
Other additions and betterments..	2,779.76	1,586.42	41,088.03
	COVERED BY EQUIPMENT TRUST SERIES "A."		
EQUIPMENT:			
Steam locomotives.....	\$2,924,556.68	Cr.917,034.65	
Passenger train cars.....	1,175,007.58	206,979.31	
Freight train cars.....	2,806,965.98	Cr.278,434.05	
Work equipment.....		98,190.17	2,791.66
Floating equipment.....		710.00	
	\$6,906,530.24	\$1,639,266.04	\$ 267,682.08 \$1,305,679.46

The following shows the amount advanced during the year to each of the subsidiary lines, these amounts being included in total advances shown in Table No. 6 of this report:

Chicago, St. Louis & New Orleans R. R.....	\$ 863,148.57
Canton, Aberdeen & Nashville R. R.....	40,694.34
South Chicago R. R.....	2,585.46
Blue Island R. R.....	474.99
Dubuque & Sioux City R. R.....	222,672.52
Kensington & Eastern R. R.....	11,973.85
Mississippi & Alabama R. R.....	13,921.11
Alabama Western R. R.....	14,884.41
Omaha Bridge & Terminal Ry.....	Cr. 2,333.81
Batesville Southwestern R. R.....	27,846.20
Bloomington Southern R. R.....	109,811.82
	\$1,305,679.46

PHYSICAL CHANGES.

The physical condition of the Company's road and equipment was materially improved and substantial additions made to its equipment.

Below are listed the principal physical improvements, the cost of which was, in whole or in part, charged to "Additions and Betterments."

**ROADWAY AND STRUCTURES:**  
 160.62 miles of track were relaid with 90 lb. new steel rail and 11.93 miles with 75 lb. new steel rail, making a total of 172.55 miles of track relaid with new steel rail; and 46.47 miles of track were relaid with second-hand rail, all replacing rail of lighter pattern. The total mileage of track relaid with new and second-hand steel rail was 219.02, exclusive of the mileage mentioned under "Maintenance of Way and Structures" on page 6.  
 One hundred and five new industrial tracks were added with an aggregate length of 16.33 miles, after deducting the industrial tracks which were taken up.

One hundred and seven new Company sidings were added, the additional mileage being 27.38, after allowing for tracks taken up.  
 Forty-four miles of partially ballasted tracks were rebalasted and brought up to present standard.

The remainder of the second main track between Ponchatoula and Orleans Junction, La., mentioned in the report for the previous year, was completed and put into operation on November 25th, 1912.

The grade crossing elimination work at Grand Crossing, Chicago, was continued, and \$119,830.43 was expended on this account during the year. There were installed and placed in operation 349.3 miles of electric automatic block signals as follows: Between Kankakee and Gilman, Ill., 54.2 miles; Mattoon Yard, Ill., 5.4 miles; between Mattoon and Sigel, Ill., 37.6 miles; between Mason and Branch Junction, Ill., 75.2 miles; between Centralia and Carbondale, Ill., 96.0 miles; between Belleville and Coulterville, Ill., 31.0 miles; between Clark Street, Chicago, and Parkway, Ill., 20.0 miles; between Scales Mound and Portage, Ill., 17.7 miles; and between Asylum and Nogan, Miss., 12.2 miles. With the trackage previously equipped, this makes a total of 1,031.9 miles of protected track as of June 30th, 1913.

Electric block signals are being installed in the following locations: At Humboldt, Ill., 6.2 miles; at Carbondale, Ill., 8.2 miles; between Coulterville and Carbondale, Ill., 48.5 miles; and between Branch Junction and Centralia, Ill., 12.0 miles, a total of 74.9 miles. The work on the first three locations is practically completed.

An interlocking plant at Manchac Bridge, La., is in process of installation. New passenger stations were erected at Pana, Ill.; Paxton, Ill.; Boos, Ill.; Oglesby, Ill.; Matlock, Iowa; and Mayfield, Ky.

New freight houses were erected at Cairo, Ill.; Manchester, Iowa; and Jackson, Miss.

Station buildings were enlarged at Christopher, Ill.; Waterloo, Iowa; White Plains, Ky.; Hazlehurst, Miss.; Belmont, Miss.; and Holcut, Miss.

The work of constructing a new passenger station building at Memphis, Tenn., to be used jointly with the St. Louis & San Francisco and Chicago, Rock Island & Pacific Companies was started during the year. Elevation of the tracks from Broadway to Huling Avenue, Memphis, is also in progress.

New mechanical coaling plants have been erected at Springfield, Ill., and Hammond, La.

A new pumping station was built at Independence, La. New wells were put down at Covington, Tenn., and Emden, Ill. Water station facilities were also improved at the following points: Pinckneyville, Ill.; Browns, Ill.; Freeport, Ill.; Carbondale, Ill.; Dubuque, Iowa; and Louisville, Ky.

A new car repair shed, replacing one destroyed by fire, was erected at East St. Louis, Ill. Frame engine houses were built at Water Valley, Miss.; Central City, Ky.; and Pinckneyville, Ill. Additions were made to the roundhouse at Dubuque, Iowa. At Cedar Rapids, Iowa, a four-story enginehouse and sand and oil house, to replace facilities destroyed by fire, were constructed. A new sand house and a new cinder pit were installed at Cairo, Ill.

Power plants were improved at the following points: 27th Street, Chicago; Burnside Shops, Ill.; Freeport, Ill.; Indianapolis, Ind.; Waterloo, Iowa; Sioux City, Iowa; Louisville, Ky.; Jackson, Tenn.; Water Valley, Miss.; and McComb, Miss.

In connection with the classification yard constructed at Centralia, Ill., a new mechanical terminal, consisting of a 48-stall roundhouse, machine, boiler and blacksmith shop, together with power house, storehouse, coaling station, wood mill, car repair shed and shops, and two water tanks, was also constructed.

The work of installing a new mechanical plant at Nonconah, Tenn., has just recently been started and is now in progress.

A new turntable was installed at Matteson, Ill. Turntables replacing ones of smaller diameter were put in at Burnside, Ill.; Cairo, Ill.; Sioux City, Iowa; Waterloo, Iowa; Dubuque, Iowa; and Canton, Miss.

The work of raising grades between Mounds and Cairo Junction, Ill., is in progress, and when completed will bring the track from Mounds south to the Ohio River bridge approach above any probable high water.

4,061 lineal feet of permanent bridges and trestles were constructed, replacing timber and pile bridges, trestles and embankments.  
 2,133 lineal feet of permanent bridges and trestles were rebuilt or replaced by embankment.

10,411 lineal feet of timber and pile bridges and trestles were rebuilt or replaced by embankment.

**EQUIPMENT:**  
 One hundred and thirty-six locomotives, consisting of fifty Mikado type freight locomotives, forty-five Pacific type passenger locomotives, and forty-one switching locomotives, were added during the year, and one hundred and thirty-four light locomotives were disposed of under lease with provision for sale, resulting in an increase of two locomotives with an increase of 1,142 tons in tractive efficiency.

One hundred and seventeen passenger train cars were added during the year, and ten cars were vacated or transferred to other service, a net increase of one hundred and seven cars.

Two thousand six hundred and eighty-eight freight train cars were added during the year, and one thousand four hundred and twenty-four cars



were sold, destroyed, or transferred to work service, a net increase of one thousand two hundred and sixty-four cars. The cars retired from service were old and of light capacity. The average capacity of cars owned at the close of the year was 40.24 tons compared with 39.57 tons last year, and the total capacity of cars was 2,266,490 tons, compared with 2,180,635 tons last year.

Of an order for two thousand five hundred fifty-ton steel gondola cars contracted for delivery in the month of March of the current year, one hundred and thirteen had been delivered up to the close of the fiscal year; but they are now coming forward regularly, and it is expected that all will be delivered before the end of November, 1913.

**GENERAL REMARKS.**

On July 1, 1912, your Company owned a number of Central of Georgia Railway Company's First, Second and Third Preference Income Bonds, and as a part of the financing by that Company, the income bonds were sold to it and your Company in turn purchased \$15,000,000 of Central of Georgia Railway Company's Six Per Cent Cumulative Preferred Stock. In liquidating the indebtedness incurred in the purchase of the above mentioned Income Bonds, your Company issued \$15,000,000 of Four and One-half Per Cent Secured Gold Notes due July 1st, 1914, pledging as collateral security for the issue the \$15,000,000 of Central of Georgia Cumulative Preferred Stock so purchased and \$4,998,500.00 of Common Stock already owned.

The past year has not been a favorable one for the issuance of long term securities; and as your Company, in carrying out the plan of adding to its equipment, desired to purchase a considerable number of large locomotives and freight cars, as well as additional new steel passenger train cars, it was considered desirable to purchase the equipment under an equipment lease. Under date of February 1st, 1913, equipment trust certificates aggregating \$8,000,000 were issued under lease and agreement known as "Illinois Central Equipment Trust, Series A," and were sold to provide in part for funds with which to pay for one hundred and thirty-five locomotives, five thousand five hundred and thirty freight train cars, and one hundred and five passenger train cars. A considerable portion of this equipment has been received during the fiscal year; but, for such as has not yet been turned over to your Company by the builders, funds with which to make payments are in the hands of the trustee of the equipment trust.

Along with a number of other railroads in the middle south, your Company suffered severely from the floods, and on March 29th, 1913, the line to the South, across the Evansville Bridge, was washed out and remained out of commission until April 12th. At the time of this occurrence it was

not thought that the water would reach such a height as to interrupt traffic on your line between Mounds and the Cairo Bridge approach; but, notwithstanding the efforts made to prevent it, the line was washed out early in the morning of April 2nd for a distance of eighteen hundred and seventy-two feet and was impassable for traffic of any description until late in the day on April 10th, when a train was moved over a single track which had been restored, but not until several days later was it possible to move traffic to any considerable extent over this portion of the line. During this entire period the Evansville Line was washed out and all communication between the North and South over your Company's lines was stopped. The result of this interruption of traffic was not only the loss of considerable revenue, but it also caused a large expenditure in restoring the portions of the railroad washed out, and resulted in a congestion of traffic which was a very expensive and disturbing matter to both the Company and its patrons.

Arrangements are now in progress to raise the line of railroad between Mounds and Cairo Junction, Ill., to such a height as, it is confidently expected, will in the future render the road immune from the ravages of floods at this important point.

While the income account shows that the operating results for the year considerably improved over those for the previous year, they are not equal to what had been hoped for; but month by month improvement has been made and the results for the last few months of the fiscal year were decidedly encouraging, the net revenue for the month of May being larger than that in any other month of May in the history of the Company, and that for the month of June closely approaching the highest net revenue in any previous June.

The directors of your Company concluded that under the unusual conditions of the last two years, not only those affecting general business but also those bearing especially hard on your Company, it was wise to declare a dividend of two and a half per cent upon the capital stock for the second six months of the fiscal year, making six per cent for the year. This was fully earned.

The number of stockholders June 30th, 1913, was 10,545, compared with 9,987 on the same date the previous year.

Four hundred and sixteen pensioners were carried on the rolls on June 30th, 1913. Pensions amounting to \$104,715.73 were paid during the fiscal year.

The fidelity and efficient services of the officers and employees are gratefully acknowledged by the Board.

By order of the Board of Directors.

C. H. MARKHAM,  
President.

**CHICAGO AND NORTH WESTERN RAILWAY COMPANY.**

**REPORT OF THE BOARD OF DIRECTORS.**

To the Stockholders of the Chicago and North Western Railway Company:

The Board of Directors submit herewith their report of the operations and affairs of the Chicago and North Western Railway Company for the fiscal year ending June 30, 1913.

Average number of miles operated, 7,974.24.

**OPERATING REVENUES:**

Freight Revenue .....	\$54,661,588.23
Passenger Revenue .....	20,557,623.25
Other Transportation Revenue .....	7,092,311.41
Nontransportation Revenue .....	724,398.19

Total Operating Revenues .....

OPERATING EXPENSES (70.15 per cent. of Operating Revenues) 58,252,780.22

Net Revenue—Rail Operations .....

OUTSIDE OPERATIONS—Net Revenue .....

Net Railway Operating Revenue .....

RAILWAY TAX ACCRUALS (4.33 per cent. of Operating Revenues) .....

Railway Operating Income.....

**OTHER INCOME:**

Rental Income .....

Dividend Income .....

Income from Funded Securities.....

Income from Unfunded Securities and Accounts, and Other Items.....

Total Other Income.....

Gross Income .....

**DEDUCTIONS FROM GROSS INCOME:**

Rental Payments .....

Interest Deductions for Funded Debt.....

Other Deductions .....

Total Deductions .....

Net Income .....

**DISPOSITION OF NET INCOME:**

Sinking Funds .....

Dividends:

8% on Preferred Stock.....

7% on Common Stock.....

Total .....

Balance Income for the year.....

The results as compared with the preceding fiscal year were as follows:

Freight Revenue increased .....	\$7,970,047.82
Passenger Revenue increased.....	1,002,056.10
Other Transportation Revenue increased.....	317,055.07
Nontransportation Revenue increased .....	48,170.51

Total Operating Revenues increased.....

Operating Expenses increased .....

Railway Tax Accruals increased.....

Operating Expenses and Railway Tax Accruals increased .....

Net Revenue from Outside Operations increased .....

5,680,923.65

Railway Operating Income increased.....

Of the Operating Expenses for the current fiscal year \$32,911,995.31, or 56.50 per cent., was paid employes for Labor, as compared with \$30,350,692.09, or 57.59 per cent., paid during the preceding fiscal year. The increase of \$2,561,303.22 in the amount paid is accounted for as follows:

Increase account higher rates of compensation.....	\$ 495,896.16
Increase account more time worked.....	2,065,407.06

\$2,561,303.22

**MILES OF RAILROAD.**

The total number of miles of railroad owned June 30, 1913, was .....

In addition to which the company operated:

THROUGH OWNERSHIP OF ENTIRE CAPITAL STOCK—

Wolf River Valley Railway (Junction east of Elton to Van Ostrand, Wis.).....

UNDER LEASE—

De Pue, Ladd & Eastern Railroad (Ladd to Seatonville, Ill.) .....

Belle Fourche Valley Railway (Belle Fourche to Newell, S. D.).....

James River Valley and North Western Railway (Blunt to Gettysburg, S. D.).....

UNDER TRACKAGE RIGHTS—

Peoria & Pekin Union Railway (in the city of Peoria, Ill.) .....

Chicago, Indiana & Southern Railroad (Churchill to Ladd, Ill.).....

Union Pacific Railroad (Broadway Station, Council Bluffs, Iowa, to South Omaha, Neb.) .....

Missouri Valley and Blair Railway and Bridge Company's track.....

Chicago, St. Paul, Minneapolis & Omaha Railway (Blair to Omaha, Neb.).....

Chicago, St. Paul, Minneapolis & Omaha Railway (Elroy to Wyeville, Wis.).....

Chicago, St. Paul, Minneapolis & Omaha Railway (in Sioux City, Iowa).....

Illinois Central Railroad (Sioux City to Wren, Iowa) .....

Total miles of railroad operated June 30, 1913.....

The above mileage is located as follows:

In Illinois .....

In Wisconsin .....

In Michigan .....

In Minnesota .....

In Iowa .....

In North Dakota .....

In South Dakota .....

In Nebraska .....

In Wyoming .....

Total .....

**FREIGHT TRAFFIC.**

The details of Freight Traffic for the year ending June 30, 1913, compared with the preceding year, were as follows:

			INCREASE	
	1912.	1913.	Amount.	Per Cent.
FREIGHT REVENUE	\$46,691,540.41	\$54,661,588.23	\$7,970,047.82	17.07
			Percentage of Increase or Decrease	
TONS OF FREIGHT CARRIED	37,265,642	44,839,071	20.32	Increase
TONS OF FREIGHT CARRIED ONE MILE	5,146,634,307	6,282,916,222	22.08	Increase
AVERAGE REVENUE RECEIVED PER TON	\$1.25	\$1.22	2.40	Decrease
AVERAGE REVENUE RECEIVED PER TON PER MILE	.91 of a cent	.87 of a cent	4.40	Decrease
AVERAGE DISTANCE EACH TON WAS HAULED	138.11 miles	140.12 miles	1.46	Increase
MILEAGE OF REVENUE FREIGHT AND MIXED TRAINS	17,216,183	18,055,815	4.88	Increase
AVERAGE NUMBER OF TONS OF REVENUE FREIGHT CARRIED PER TRAIN MILE:				
East of Missouri River	324.36	375.38	15.73	Increase
West of Missouri River	136.93	148.68	8.58	Increase
Whole Road	298.94	347.97	16.40	Increase
AVERAGE NUMBER OF TONS OF REVENUE FREIGHT CARRIED PER LOADED CAR MILE	16.87	18.38	8.95	Increase
AVERAGE FREIGHT REVENUE PER TRAIN MILE	\$2.71	\$3.03	11.81	Increase

**PASSENGER TRAFFIC.**

The details of Passenger Traffic for the year ending June 30, 1913, compared with the preceding year, were as follows:

			INCREASE	
	1912.	1913.	Amount.	Per Cent.
PASSENGER REVENUE	\$19,555,567.15	\$20,557,623.25	\$1,002,056.10	5.12
			Percentage of Increase	
PASSENGERS CARRIED	31,526,803	32,441,450	2.90	Increase
PASSENGERS CARRIED ONE MILE	1,080,580,440	1,113,831,352	3.08	Increase
AVERAGE FARE PAID PER PASSENGER	62 cents	63 cents	1.61	Increase
AVERAGE RATE PAID PER PASSENGER PER MILE	1.81 cents	1.85 cents	2.21	Increase
AVERAGE DISTANCE TRAVELED PER PASSENGER	34.28 miles	34.33 miles	.15	Increase
MILEAGE OF REVENUE PASSENGER AND MIXED TRAINS	21,232,249	21,378,704	.69	Increase
AVERAGE PASSENGER-TRAIN REVENUE PER TRAIN MILE	\$1.17	\$1.23	5.13	Increase

**MAINTENANCE OF WAY AND STRUCTURES.**

The total Operating Expenses of the Company for the year ending June 30, 1913, were \$58,252,780.22; of this amount \$11,501,186.43 was for charges pertaining to the Maintenance of Way and Structures. Included in these charges is a large part of the cost of 79,495 tons of steel rails, the greater portion of which was laid in replacement of rails of lighter weight in 559.00 miles of track; also the cost of 2,717,525 new ties.

The charges for Maintenance of Way and Structures also include a portion of the cost of ballasting 143.16 miles of track with crushed stone, 92.69 miles with gravel, and 15.73 miles with cinders; the erection in place of wooden structures, of 29 new steel bridges on masonry, and 3 on pile supports, aggregating 3,070 feet in length and containing 2,655 tons of bridge metal; and the replacement of other wooden structures with masonry arch and box culverts and cast-iron pipes, the openings being filled with earth. The wooden structures replaced by permanent work aggregate 6,243 feet in length.

The charges on account of Maintenance of Way and Structures for the year ending June 30, 1913, compared with the preceding year, were as follows:

	1912.	1913.	Increase or Decrease.
<b>COST OF RAILS:</b>			
New steel rails	\$684,098.02	\$1,608,212.85	\$924,114.83 Inc.
Usable and re-rolled rails	517,029.13	589,407.15	72,378.02 Inc.
	\$1,201,127.15	\$2,197,620.00	\$996,492.85 Inc.
Less value of old rails and other items	858,802.36	1,582,238.40	723,436.04 Inc.
Net charge for rails	\$342,324.79	\$615,381.60	\$273,056.81 Inc.
<b>COST OF TIES</b>	1,089,639.61	1,398,359.45	308,719.84 Inc.
<b>COST OF BALLAST</b>	270,889.41	193,644.46	77,244.95 Dec.
<b>COST OF OTHER TRACK MATERIAL</b>	332,143.11	525,805.53	193,662.42 Inc.
<b>ROADWAY AND TRACK LABOR AND OTHER EXPENSES</b>	3,971,729.48	4,949,338.52	977,609.04 Inc.
Total Charges for Roadway and Track	\$6,006,726.40	\$7,682,529.56	\$1,675,803.16 Inc.
Other Charges Account Maintenance of Way and Structures were as follows:			
BRIDGES, TRUSTLES AND CULVERTS	982,706.24	854,794.52	127,911.72 Dec.
ROAD CROSSINGS, FENCES, ETC.	228,930.65	325,226.84	96,296.19 Inc.
SIGNALS AND INTERLOCKING PLANTS	314,857.72	444,175.32	129,317.60 Inc.
BUILDINGS, FIXTURES AND GROUNDS	977,028.80	1,175,886.10	198,857.30 Inc.
DOCKS AND WHARVES	130,497.71	214,950.50	84,452.79 Inc.
SUPERINTENDENCE	463,546.88	483,468.65	19,921.77 Inc.
ROADWAY TOOLS AND SUPPLIES	92,885.00	139,863.67	46,978.67 Inc.
SUNDRY MISCELLANEOUS CHARGES	171,541.79	180,291.27	8,749.48 Inc.

Total Charges Account Maintenance of Way and Structures \$9,368,721.19 \$11,501,186.43 \$2,132,465.24 Inc. The above charges for Maintenance of Way and Structures for the current year amount to 19.74 per cent. of the total Operating Expenses, as compared with 17.78 per cent. for the preceding fiscal year.

**MAINTENANCE OF EQUIPMENT.**

The charges on account of Maintenance of Equipment for the year ending June 30, 1913, compared with the preceding year, were as follows:

	1912.	1913.	Increase or Decrease.
LOCOMOTIVES	\$4,167,982.40	\$4,688,207.05	\$520,224.65 Inc.
PASSENGER-TRAIN CARS	907,629.77	1,088,442.20	180,812.43 Inc.
FREIGHT-TRAIN CARS	3,764,638.33	5,016,122.00	1,251,483.67 Inc.
WORK EQUIPMENT	99,451.93	132,975.41	33,523.48 Inc.
SHOP MACHINERY AND TOOLS	241,971.21	229,505.27	12,465.94 Dec.
SUPERINTENDENCE	310,815.69	335,106.49	24,290.80 Inc.
SUNDRY MISCELLANEOUS CHARGES	77,363.82	78,137.67	773.85 Inc.

Total Charges Account Maintenance of Equipment \$9,569,853.15 \$11,568,496.09 \$1,998,642.94 Inc. The above charges for Maintenance of Equipment for the current year amount to 19.86 per cent. of the total Operating Expenses, as compared with 18.16 per cent. for the preceding fiscal year.

**RESERVE FOR ACCRUED DEPRECIATION ON EQUIPMENT.**

At the close of the preceding fiscal year there was a balance to the credit of the Equipment Reserve Accounts of \$3,375,862.22

During the year ending June 30, 1913, there was credited to the Equipment Reserve Accounts on account of charges to Operating Expenses and Profit and Loss, and for salvage \$3,558,807.62

And there has been charged during the year against the above amount the original cost of Equipment retired and other items, as follows:		
49 Locomotives	\$413,117.15	
14 Passenger-Train Cars	68,984.78	
2,242 Freight-Train Cars	1,306,815.95	
186 Work Equipment Cars	40,444.80	
Other Items	439,594.88	
		\$6,934,669.84

Leaving a balance to the credit of the Equipment Reserve Accounts on June 30, 1913, of \$4,665,712.28

**TRANSPORTATION EXPENSES.**

The Transportation Expenses of the Company for the year ending June 30, 1913, were \$32,241,257.68, or 55.35 per cent. of the total Operating Expenses. Of this amount \$19,626,078.01, or 60.87 per cent., was charged for labor; \$7,925,888.13, or 24.58 per cent., was charged for fuel for locomotives; and \$4,689,291.54, or 14.55 per cent., was charged for supplies and miscellaneous items. The increase in the Transportation Expenses for the year ending June 30, 1913, as compared with the preceding fiscal year, was \$1,316,319.38, or 4.26 per cent., distributed as follows:

Increase in amount charged for labor	\$834,691.79
Increase in amount charged for fuel for locomotives	264,620.51
Increase in amount charged for supplies and miscellaneous items	217,007.08
	\$1,316,319.38

**CAPITAL STOCK.**

There was no change during the year in the Capital Stock and Scrip of the Company other than the purchase by the Company of \$75.00 Common Stock Scrip.

The Company's authorized Capital Stock is Two Hundred Million Dollars (\$200,000,000.00), of which the following has been issued to June 30, 1913:

Common Stock and Scrip held by the public	\$130,117,028.82
Common Stock and Scrip owned by the Company	2,338,502.15
Total Common Stock and Scrip	\$132,455,530.97
Preferred Stock and Scrip held by the Public	\$22,395,120.00
Preferred Stock and Scrip owned by the Company	3,834.56
Total Preferred Stock and Scrip	22,398,954.56
Total Capital Stock and Scrip, June 30, 1913	\$154,854,485.53

**FUNDED DEBT.**

At the close of the preceding fiscal year the amount of Bonds held by the Public and in Sinking Funds was \$184,079,000.00

The above amount has been decreased during the year ending June 30, 1913, as follows:

<b>BONDS REDEEMED WITH SINKING FUND PAYMENTS:</b>	
C. & N. W. Ry. Sinking Fund of 1879, 6%	\$55,000.00
C. & N. W. Ry. Sinking Fund of 1879, 5%	85,000.00
Total Bonds Redeemed	140,000.00
	\$183,939,000.00

And the above amount has been increased by Equipment Trust Certificates sold and Bonds assumed during the year, as follows:

C. & N. W. Ry. 4 1/2% Equipment Trust Certificates of 1912, sold	\$5,700,000.00
Des Plaines Valley Ry. 4 1/2% First Mortgage Bonds assumed	2,500,000.00
St. Paul Eastern Grand Trunk Ry. 4 1/2% First Mortgage Bonds assumed	1,120,000.00
	9,320,000.00
Total Bonds held by the Public and in Sinking Funds, June 30, 1913	\$193,259,000.00
Net Increase during the year in Bonds held by the Public and in Sinking Funds	\$9,180,000.00

## BONDS IN THE TREASURY AND DUE FROM TRUSTEE.

At the close of the preceding fiscal year the amount of the Company's Bonds in its Treasury and due from Trustee was... \$6,381,000.00

The above amount has been increased during the year ending June 30, 1913, as follows:

C. & N. W. Ry. GENERAL MORTGAGE GOLD BONDS OF 1987, DUE FROM TRUSTEE IN EXCHANGE FOR BONDS RETIRED, VIZ.:		
C. & N. W. Ry. Sinking Fund of 1879, 6%..	\$52,000.00	
C. & N. W. Ry. Sinking Fund of 1879, 5%..	86,000.00	
	\$138,000.00	
C. & N. W. Ry. GENERAL MORTGAGE GOLD BONDS OF 1987, DUE FROM TRUSTEE ON ACCOUNT OF CONSTRUCTION EXPENDITURES MADE DURING THE YEAR .....	1,000,000.00	1,138,000.00
Total Bonds in the Treasury and due from Trustee, June 30, 1913 .....		\$7,519,000.00
Net Increase during the year in Bonds in the Treasury and due from Trustee .....		\$1,138,000.00

## CONSTRUCTION.

The construction charges for the year ending June 30, 1913, were as follows:

ON ACCOUNT OF ELEVATING TRACKS, VIZ.:		
North 46th Avenue to Austin Avenue, Chicago, Ill. ....	\$200.57	
Austin Avenue to Harlem Avenue, Oak Park, Ill. ....	10,263.15	
Harlem Avenue, Oak Park, Ill., to Des Plaines River .....	80,187.10	
South Branch Track, from near Taylor Street to Canal Street, Chicago, Ill. ....	1,416.39	\$92,067.21

## SUNDRY CONSTRUCTION:

Right of Way and Additional Depot and Yard Grounds .....	\$124,051.13	
Buildings and Fixtures .....	519,900.76	
Docks and Wharves .....	59,004.85	
Shop Machinery and Tools .....	62,215.60	
Bridges, Trestles and Culverts .....	570,675.28	
Interlocking and Signal Apparatus .....	345,202.66	
Telephone Lines .....	110,802.09	
New Sidings, Yard Tracks and Spurs to Industries .....	53,556.49	
Betterment of Roadway and Track .....	1,110,201.00	
Proviso, Ill., Terminal Improvements .....	148,236.03	
Proviso, Ill., Overhead Highway Crossing .....	105,771.00	
Miscellaneous Construction, including Road Crossings, Fences and other items .....	246,216.75	3,455,833.64

## EQUIPMENT:

1 Locomotive, 251 Freight-Train Cars, and 82 Work Equipment Cars .....	\$321,419.14	
Improvement of Equipment .....	231,010.16	
Trust Equipment of 1912 added:		
75 Locomotives, 55 Steel Passenger-Train Cars and 4,910 Freight-Train Cars .....	6,000,140.45	
	\$6,552,569.75	
Less Equipment retired .....	2,268,957.56	4,283,612.19

Account Cost of Milwaukee, Sparta and North Western Railway .....	\$7,831,513.04
Account Cost of Des Plaines Valley Railway .....	587,801.05
Account Cost of St. Paul Eastern Grand Trunk Railway .....	2,498,669.45
Cost of St. Paul Eastern Grand Trunk Railway .....	1,120,600.00
	\$12,038,583.54

## SUNDRY ADDITIONS AND BETTERMENTS.

Among the more important sundry additions and betterments to the property of the Company during the fiscal year are the following:

An aggregate of 54.00 miles of yard tracks, sidings and industrial spurs has been added.

To provide for additional yard tracks, the Company has acquired during the year approximately 60 acres of land adjoining its right of way north of and near Waukegan, Illinois, and approximately 186 acres of land adjoining its right of way near Kenosha, Wisconsin.

At the Chicago Passenger Terminal an unfinished space under the train shed, approximately 200 feet by 280 feet, has been utilized in providing sanitary and convenient quarters for the Dining Car Department.

At Chicago Avenue, Chicago, a brick power house, 38 feet by 85 feet, has been constructed and the engine house enlarged sufficiently to accommodate the Company's largest type of locomotive.

At the Chicago Shops a modern hot water boiler washout system has been installed in a new building constructed for that purpose, and a building 40 feet by 176 feet has been constructed in which machinery will be installed for reclaiming usable material.

At Proviso, Illinois, an overhead bridge, approximately 3,000 feet in length, including approaches, has been constructed at the Wolf Road crossing to permit highway traffic to pass over this Company's freight terminal yards.

At West Chicago, Illinois, a modern brick passenger station has been completed and important additions and alterations have been made in yard and track facilities. The building formerly used as a passenger station has been moved to a new location for use as a freight station. An overhead highway bridge connecting Parker Avenue and Depot Street has been constructed and the construction of an overhead highway bridge extending Maple Avenue across the Company's tracks is in progress.

At Evansville, Wisconsin, and at Waseca, Minnesota, modern brick passenger stations have been completed.

At Clinton, Iowa, a 425-foot extension to the Company's ice house has been constructed, the icing platform has been changed from single to double deck and equipped with conveyors. Electric power for the operation of machinery has been installed.

At Clinton, Iowa, there are also under construction a 9-stall engine machine shop, an 8-stall engine machine shop, power house, store and office building and an engineers' and firemen's building which it is expected will be completed during the present calendar year.

At Council Bluffs, Iowa, a brick freight house 258 feet by 40 feet, brick office building 33 feet by 35 feet, boiler house, machinery and transfer platforms and necessary track changes have been completed.

At Omaha, Nebraska, this Company has, jointly with the Chicago, Saint Paul, Minneapolis and Omaha Railway Company, constructed a 15-stall brick engine house, a machine shop 50 feet by 140 feet, an oil house, and installed an 80-foot turntable.

At Milwaukee, Wisconsin, a two-story brick freight house 50 feet by 360 feet has been constructed on land recently acquired by this Company on the east side of Van Buren Street.

At Green Bay, Wisconsin, a 40-stall brick engine house, power house, store and oil house, cinder pit, turntable, coal and water station and ice house, including necessary trackage, are under construction.

At Ashland, Wisconsin, Ore Dock No. 1 has been partially rebuilt and its total capacity materially increased.

In extending the use of oil as a locomotive fuel on the Company's Nebraska and Wyoming lines, 81 additional locomotives have been equipped with oil burners; 70 additional tank cars have been purchased, and plants for the storage of fuel oil have been installed at 13 stations during the year.

Thus far 113 locomotives have been equipped with oil burners, 95 tank cars have been acquired and 16 storage tanks installed. Pumps and pump-houses have been constructed at various stations west of the Missouri River and warming sheds have been constructed at Chadron, Nebraska, and Casper, Wyoming.

In complying with statutes enacted by the Legislatures of Wisconsin, Michigan, Minnesota, Iowa and South Dakota, a considerable expenditure has been made during the year for equipping locomotives with electric headlights.

The installation of automatic block signals between Harvard, Illinois, and Evansville, Wisconsin, a distance of 44 miles, and between Madison and Baraboo, Wisconsin, a distance of 38 miles, has been completed during the year and automatic block signals are being installed between Evansville and Madison, Wisconsin, a distance of 22.5 miles, and between Baraboo and Elroy, Wisconsin, a distance of 37.3 miles. Upon the completion of the work now in progress 957 miles of the Company's railway will be protected by automatic signals.

A telephone line for use in dispatching trains has been completed during the year from Chicago, Illinois, to Clinton, Iowa, a distance of 138 miles, which provides a continuous telephone line from Chicago to Council Bluffs. Telephone lines for like use are being installed from Nelson to Peoria, Illinois, a distance of 81.9 miles; Huron, South Dakota, to Hawarden, Iowa, a distance of 144.3 miles; and from Centerville to Yankton, South Dakota, a distance of 28.5 miles. Upon the completion of these lines the Company will have in operation 2,172.7 miles of telephone lines for use in dispatching trains.

## NEW RAILWAYS.

The DES PLAINES VALLEY RAILWAY, a double track outer belt railway, constructed in the interest of this Company, from the Proviso Yard on the Galena Division to a point between Northfield and Blodgett, Illinois, on the Wisconsin Division, a distance of 20.51 miles, has been completed. This railway was purchased and its indebtedness, consisting of \$2,500,000 First Mortgage 4½% Gold Bonds, payable March 1, 1947, was assumed by this Company on March 1, 1913.

The ST. PAUL EASTERN GRAND TRUNK RAILWAY, a proprietary railway, approximately 60.02 miles in length, extending from Clintonville to Oconto, Wisconsin, formerly operated by this Company under lease, was purchased and its indebtedness, consisting of \$1,120,000 First Mortgage 4½% Gold Bonds, payable January 1, 1947, was assumed by this Company on March 1, 1913.

The ST. LOUIS, PEORIA AND NORTH WESTERN RAILWAY, under construction in the interest of this Company from near Peoria to near Girard, Illinois, a distance of 90.6 miles, is nearly completed. On June 18, 1913, the St. Louis, Peoria and North Western Railway Company acquired by purchase the Macoupin County Railway, a proprietary railway, extending from near Girard to the Company's coal fields in Macoupin County, Illinois, a distance of 23.9 miles.

The MACOUPIN COUNTY EXTENSION RAILWAY COMPANY was organized in the interest of this Company in May, 1913, to construct a railway from a connection with the Macoupin County Railway, near Bend in a general southerly direction for a distance of about nine miles to reach certain coal fields under development in Macoupin and Madison Counties, Illinois.

The IOWA SOUTHERN RAILWAY COMPANY was organized in the interest of this Company in January, 1913, to construct a railway from a connection with this Company's railway in Monroe County, Iowa, in a general southwesterly direction in that County for a distance of about 25 miles. Approximately 13 miles of this railway are now under construction.

## EQUIPMENT TRUST OF 1912.

The following equipment acquired pursuant to the agreement establishing the Chicago and North Western Railway Company Equipment Trust of 1912, to which reference was made in the last annual report, has been delivered and leased by this Company from The Farmers' Loan and Trust Company and Edwin S. Marston, Trustees, and the plates, or insignia of ownership, required by the agreement, have been attached thereto during the year:

SERIES A:	
75 locomotives,	
55 steel, passenger-train cars,	
483 refrigerator cars,	
500 flat cars,	
257 box cars.	
SERIES B:	
517 refrigerator cars,	
3,153 box cars.	

The following Equipment Trust Certificates, bearing interest at the rate of 4½% per annum, issued by The Farmers' Loan and Trust Company, Trustee, on account of the foregoing equipment have been sold during the year:

SERIES A:	
Certificates dated July 1, 1912, maturing at the rate of \$300,000 per annum on July 1, 1914, to July 1, 1922, inclusive .....	\$2,700,000
NOTE.—The certificates maturing July 1, 1913, aggregating \$300,000, were not sold.	
SERIES B:	
Certificates dated October 1, 1912, maturing at the rate of \$300,000 per annum on October 1, 1913, to October 1, 1922, inclusive .....	3,000,000
	\$5,700,000

Contracts have been made by the Vendors under the Equipment Trust of 1912 for the following equipment to be included in Series C of that Trust, which will complete the acquisition of equipment under the Equipment Trust Agreement of 1912:

4 locomotives,
2,000 gondola cars,
2,005 box cars.

Upon the delivery of this equipment, which is nearly completed, it will be conveyed by the Vendors to the Trustees and leased by this Company and thereupon Equipment Trust Certificates, Series C, will be issued pursuant to the agreement, in an amount not exceeding the cost of the equipment.

**EQUIPMENT TRUST OF 1913**

To make further provision for the acquisition of additional equipment, an agreement, sanctioned by the Board of Directors, and identical in terms with the agreement establishing the Equipment Trust of 1912, was entered into by this Company with the same Trustees and Vendors, on January 20, 1913, establishing the Chicago and North Western Railway Company Equipment Trust of 1913, under which provision has been made for the issuance of Equipment Trust Certificates to an amount not to exceed the cost of the equipment acquired thereunder and in no event to exceed \$10,000,000.00.

Contracts have been made by the Vendors for the following equipment which will be included in the first series of this Trust, to be known as Series D, the delivery of which is nearly completed:

- 71 locomotives,
- 68 steel, passenger-train cars,
- 495 box cars,
- 1,000 ore cars,
- 500 flat cars,
- 40 caboose cars.

**LANDS.**

During the year ending June 30, 1913, 19,609.26 acres and 75 town lots

of the Company's Land Grant lands have been sold for the total consideration of \$578,775.59. The total number of acres remaining in the several Grants June 30, 1913, amounted to 355,293.56 acres, of which 34,677.34 acres were under contract for sale, leaving unsold 320,616.22 acres.

A tract of land fronting on the Calumet River south of 118th Street in Chicago, containing approximately 116 acres, has been acquired by the Company during the year. This land is adjacent to tracks controlled by the Indiana Harbor Belt Railroad Company, in which railway this Company has acquired a substantial interest. This acquisition will provide a location for facilities needed by the Chicago and North Western Railway Company in that district. The expenditure on this account is temporarily carried on the Company's Balance Sheet in "Deferred Debit Items."

An agreement sanctioned by the Board of Directors, was entered into on April 10, 1913, with the City of Milwaukee, by the terms of which this Company acquired the right to fill in, and occupy with additional tracks, approximately ten acres of submerged lands east of its present holdings on the shore of Lake Michigan in that City, in exchange for its riparian rights and approximately eight acres of certain accreted land north of Juneau Park. The agreement also establishes the boundary line between the holdings of this Company and those of the City on the lake front.

Appended hereto may be found statements, accounts and statistics relating to the business of the fiscal year, and the condition of the Company's affairs on June 30, 1913.

By order of the Board of Directors.

**WILLIAM A. GARDNER,**  
*President.*

**GENERAL BALANCE SHEET, JUNE 30, 1913.**

(7,830.86 Miles.)

ASSETS.	LIABILITIES.
<b>PROPERTY INVESTMENT:</b>	<b>CAPITAL STOCK:</b>
Road and Equipment—	Common Stock and Scrip, C. & N. W. Ry. Co., held by the Public.....\$130,117,028.82
Balance to Debit of this Account, June 30, 1912 .....	Preferred Stock and Scrip, C. & N. W. Ry. Co., held by the Public..... 22,395,120.00
Add Sundry Construction and Equipment Expenditures for the year ending June 30, 1913 (including trust equipment), as see statement elsewhere herein .....	Common Stock and Scrip, C. & N. W. Ry. Co., owned by the Company..... \$2,338,502.15
" Account Cost of Milwaukee, Sparta and North Western Railway.....	Preferred Stock and Scrip, C. & N. W. Ry. Co., owned by the Company..... 3,834.56
" Account Cost of Des Plaines Valley Railway .....	Premium Realized on Capital Stock.....
" Cost of St. Paul Eastern Grand Trunk Railway .....	
	<u>2,342,336.71</u>
	29,657.75
	<u>\$154,884,143.28</u>
	<b>MORTGAGE, BONDED AND SECURED DEBT:</b>
Securities—	Bonds in hands of the Public.....\$174,804,500.00
Securities of Proprietary, Affiliated and Controlled Companies—Unpledged .....	Equipment Trust Certificates in hands of the Public .....
1,492,013.15	C. & N. W. Ry. Sinking Fund Debentures of 1933, in hands of the Public, issued for purchase of Stock of C. St. P. M. & O. Ry. Co.....
<b>Other Investments—</b>	9,695,000.00
Advances to Proprietary, Affiliated and Controlled Companies for Construction, Equipment and Betterments....	Bonds held by Trustee account Sinking Funds .....
\$17,831,122.13	3,059,500.00
Miscellaneous Investments .....	Bonds owned by the Company and due from Trustee .....
939,425.23	7,519,000.00
	200,778,000.00
	<b>WORKING LIABILITIES:</b>
	Traffic and Car-Service Balances Due to Other Companies.....
	\$1,661,242.38
	Audited Vouchers and Wages Unpaid....
	5,244,791.28
	Miscellaneous Accounts Payable.....
	171,313.96
	Matured Interest, Dividends and Rents Unpaid .....
	3,101,004.54
	Other Working Liabilities.....
	241,391.09
	10,419,743.25
	<b>ACCRUED LIABILITIES NOT DUE:</b>
	Unmatured Interest Payable.....
	\$1,930,783.35
	Taxes Accrued .....
	60,000.00
	1,990,783.35
	<b>DEFERRED CREDIT ITEMS:</b>
	Reserve for Accrued Depreciation on Equipment .....
	\$4,665,712.28
	Other Deferred Credit Items.....
	435,671.26
	5,101,383.54
	<b>APPROPRIATED SURPLUS:</b>
	Sinking Fund on Madison Extension Gold Bonds .....
	\$67,543.86
	" " " Menominee Extension Gold Bonds .....
	112,270.49
	" " " North Western Union Ry. Gold Bonds .....
	1,520,893.41
	" " " W. & St. P. R. Extension Gold Bonds...
	2,275,341.27
	3,976,049.03
	<b>PROFIT AND LOSS.....</b>
	36,438,744.36
	<u>\$413,588,846.81</u>

**PROFIT AND LOSS ACCOUNT, JUNE 30, 1913.**

<b>DR.</b>	
Depreciation accrued prior to July 1, 1907, on equipment retired or changed from one class to another during the current fiscal year .....	\$1,364,199.95
Net loss on property sold or abandoned and not replaced..	380,673.56
Balance Credit, June 30, 1913, carried to Balance Sheet...	36,438,744.36
	<u>\$38,183,617.87</u>
	<b>CR.</b>
Balance, June 30, 1912.....	\$34,186,372.05
Balance Income for Year ending June 30, 1913, brought forward from Income Account.....	3,775,407.72
Amount transferred from "Appropriated Surplus" on account of the retirement of Madison Extension and Menominee Extension First Mortgage Sinking Fund Bonds.....	199,361.07
Adjustments in sundry accounts, etc.....	22,477.55
	<u>\$38,183,617.87</u>

COMPARATIVE STATEMENT OF INCOME ACCOUNT.

	Year Ending June 30, 1912.	Year Ending June 30, 1913.	Increase or Decrease.
Average Mileage Operated....	7,858.87	7,974.24	115.37
<b>OPERATING REVENUES:</b>			
Freight Revenue .....	\$46,691,540.41	\$54,661,588.23	\$7,970,047.82
Passenger Revenue .....	19,555,567.15	20,557,623.25	1,002,056.10
Other Transportation Revenue .....	6,775,256.34	7,092,311.41	317,055.07
Non-transportation Revenue..	676,227.68	724,398.19	48,170.51
Total Operating Revenues..	\$73,698,591.58	\$83,035,921.08	\$9,337,329.50
<b>OPERATING EXPENSES:</b>			
Net Revenue—Rail Opera- tions .....	\$20,996,748.28	\$24,783,140.86	\$3,786,392.58
OUTSIDE OPERATIONS—Net Rev- enue .....	Dr. 33,038.59	11,296.35	44,334.94
Net Railway Operating Rev- enue .....	\$20,963,709.69	\$24,794,437.21	\$3,830,727.52
RAILWAY TAX ACCRUALS .....	3,422,838.13	3,597,159.80	174,321.67
Railway Operating Income..	\$17,540,871.56	\$21,197,277.41	\$3,656,405.85
<b>OTHER INCOME:</b>			
Rental Income .....	168,884.24	191,209.04	22,324.80
Dividend Income .....	1,844,722.00	1,836,922.00	-7,800.00

Income from Funded Securi- ties .....	5,025.00	53,433.33	48,408.33
Income from Unfunded Sec- urities and Accounts, and Other Items .....	1,363,263.28	1,381,927.54	18,664.26
Total Other Income....	\$3,381,894.52	\$3,463,491.91	\$81,597.39
Gross Income .....	\$20,922,766.08	\$24,660,769.32	\$3,738,003.24
<b>DEDUCTIONS FROM GROSS INCOME:</b>			
Rental Payments .....	1,194,791.02	1,194,268.52	-522.50
Interest Deductions for Fund- ed Debt .....	7,872,007.25	8,529,266.49	657,259.24
Other Deductions .....	131,427.98	62,220.84	-69,207.14
Total Deductions .....	\$9,198,226.25	\$9,785,755.85	\$587,529.60
Net Income .....	\$11,724,539.83	\$14,875,013.47	\$3,150,473.64
<b>DISPOSITION OF NET INCOME:</b>			
Sinking Funds .....	257,209.23	199,990.75	-57,218.48
<b>Dividends:</b>			
8% on Preferred Stock....	1,791,600.00	1,791,600.00	.....
7% on Common Stock.....	9,108,015.00	9,108,015.00	.....
Total .....	\$11,156,824.23	\$11,099,605.75	-\$57,218.48
Balance Income for the year, carried to Profit and Loss .....	\$567,715.60	\$3,775,407.72	\$3,207,692.12

CHICAGO, SAINT PAUL, MINNEAPOLIS AND OMAHA RAILWAY COMPANY.

REPORT OF THE BOARD OF DIRECTORS.

To the Stockholders of the Chicago, Saint Paul, Minneapolis and Omaha Railway Company:

The Board of Directors submit herewith their report of the operations and affairs of the Chicago, Saint Paul, Minneapolis and Omaha Railway Company for the fiscal year ending June 30, 1913.

Average number of miles operated, 1,746.84

OPERATING REVENUES.	
Freight revenue .....	\$10,857,206.93
Passenger revenue .....	4,984,595.31
Other transportation revenue .....	1,056,864.00
Non-transportation revenue .....	94,338.44
Total operating revenue.....	\$16,993,004.68

OPERATING EXPENSES (69.95 per cent. of operating revenues) ..	11,887,461.28
Net operating revenue .....	\$5,105,543.40

OUTSIDE OPERATIONS (net deficit).....	
	4,811.62
Total net revenue.....	\$5,100,731.78

RAILWAY TAX ACCRUALS (4.90 per cent. of operating revenue) ..	832,263.27
Railway operating income.....	\$4,268,468.51

OTHER INCOME.	
Rental Income .....	\$136,257.28
Dividend income .....	46,351.00
Income from funded securities.....	11,900.00
Income from unfunded securities and accounts, and other items.....	41,294.81
Total other income.....	235,803.09

Gross income .....	\$4,504,271.60
--------------------	----------------

DEDUCTIONS FROM GROSS INCOME.	
Rental payments .....	\$387,159.70
Interest deductions for funded debt.....	1,826,264.05
Other deductions .....	11,914.54
Total deductions .....	2,225,338.29

Net income .....	\$2,278,933.31
------------------	----------------

DISPOSITION OF NET INCOME.	
<b>Dividends:</b>	
7% on preferred stock.....	\$787,976.00
7% on common stock.....	1,298,934.00
Total dividends .....	2,086,910.00
Balance income for the year.....	\$192,023.31

As compared with the previous year, the results were as follows:	
Freight revenue increased.....	\$1,378,415.08
Passenger revenue increased.....	433,001.45
Other transportation revenue increased.....	47,640.67
Non-transportation revenues decreased.....	\$1,859,057.20
Total operating revenue increased.....	\$1,857,578.60

Operating expenses increased.....	\$1,421,244.79
Railway tax accruals increased.....	49,417.32
Operating expenses and railway tax accruals increased .....	\$1,470,662.11
Net deficit from outside operations increased.....	78.94
Railway operating income increased.....	\$386,837.55

Of the operating expenses for the current fiscal year \$6,721,181.33, or 56.54 per cent, was paid employees for labor, as compared with \$6,159,663.03, or 58.85 per cent, paid during the preceding fiscal year. The increase of \$561,518.30 in the amount paid is accounted for as follows:	
Increase account higher rates of compensation.....	\$ 86,062.59
Increase account more time worked.....	475,455.71
Total increase .....	\$561,518.30

MILES OF RAILROAD.

The total number of miles of railroad owned June 30, 1913, was 1,677.50 miles

In addition to which the company operated:

Under Trackage Rights—	
Northern Pacific Railway (Superior, Wis., to Rices Point, Minn.).....	1.59 miles
Great Northern Railway (St. Paul to Minne- apolis, Minn.) .....	11.40 "
Minneapolis & St. Louis Railroad (Minne- apolis to Merriam, Minn.) .....	27.00 "
Illinois Central Railroad (LeMars to Sioux City, Iowa) .....	25.20 "
Sioux City Bridge Company (bridge across Missouri River and tracks at Sioux City, Iowa) .....	3.90 "
Chicago and Northwestern Railway (Sioux City to Sioux City Bridge Company's track) ..	.50 " 69.59 "
Total miles of railroad operated June 30, 1913.....	1,747.09 "

The above mileage is located as follows:

In Wisconsin .....	775.42 miles
In Minnesota .....	473.04 "
In Iowa .....	102.04 "
In South Dakota.....	88.20 "
In Nebraska .....	308.39 "
Total .....	1,747.09 "

In addition to the foregoing, the company owned and operated 156.62 miles of second track, located as follows:

In Wisconsin .....	130.68 miles
In Minnesota .....	24.23 "
In Nebraska .....	1.71 "
Total .....	156.62 "

FREIGHT TRAFFIC.

The details of freight traffic for the year ending June 30, 1913, compared with the preceding year, were as follows:

	1912.	1913.	INCREASE	
			Amount.	Per Cent.
Freight revenue .....	\$9,478,791.85	\$10,857,206.93	\$1,378,415.08	14.54
Tons of freight carried.....	6,946,804	8,205,947	18.13	Increase
Tons of freight carried one mile .....	1,092,173,586	1,262,998,028	15.64	Increase
Average revenue received per ton .....	\$1.36	\$1.32	2.94	Decrease
Average revenue received per ton per mile.....	.87 of a cent	.86 of a cent	.92	Decrease
Average distance each ton was hauled .....	157.22 miles	153.91 miles	2.11	Decrease
Mileage of revenue freight and mixed trains .....	4,382,665	4,575,954	4.41	Increase
Average number of tons of revenue freight carried per train mile .....	249.20	276.01	10.76	Increase
Average number of tons of revenue freight carried per loaded car mile.....	17.62	18.99	7.78	Increase
Average freight revenue per train mile .....	\$2.16	\$2.37	9.72	Increase

PASSENGER TRAFFIC.

The details of passenger traffic for the year ending June 30, 1913, compared with the preceding year, were as follows:

	1912.	1913.	INCREASE	
			Amount.	Per Cent.
Passenger revenue .....	\$4,551,593.86	\$4,984,595.31	\$433,001.45	9.51

	1912.	1913.	Percentage of Increase or Decrease
Passengers carried .....	4,263,640	4,500,947	5.57 Increase
Passengers carried one mile...	220,979,696	234,545,623	6.14 Increase
Average fare paid per passenger	106.75 cents	110.75 cents	3.75 Increase
Average rate paid per passenger per mile .....	2.060 cents	2.125 cents	3.16 Increase
Average distance traveled per passenger .....	51.83 miles	52.11 miles	.54 Increase
Mileage of revenue passenger and mixed trains .....	4,393,349	4,489,183	2.18 Increase
Average passenger train revenue per train mile .....	\$1.23	\$1.31	6.50 Increase

**MAINTENANCE OF WAY AND STRUCTURES.**

The total operating expenses of the company for the year ending June 30, 1913, were \$11,887,461.28; of this amount \$2,208,293.60 was for charges pertaining to maintenance of way and structures. Included in these charges are \$203,737.34 for rails, \$326,294.47 for ties, and the cost of re-ballasting 33,06 miles with gravel and cinders, also part cost of replacing 860 feet of wooden bridging with permanent work.

During the year 12,552 tons of new steel rails and 11,213 tons of usable and re-rolled steel rails were laid in track, a greater portion of which replaced rails of lighter weight; 631,272 ties of all descriptions were laid in renewals.

The details of the charges to maintenance of way and structures for the year, compared with the previous year, were as follows:

Cost of RAILS.	1912.	1913.	Inc. or Dec.
New steel rail .....	\$244,835.32	\$398,243.49	\$153,408.17
Usable and re-rolled rail.....	138,466.60	279,678.91	141,212.31
	<u>\$383,301.92</u>	<u>\$677,922.40</u>	<u>\$294,620.48</u>
Less value of old rails and other items .....	274,466.59	474,185.06	199,718.47
Net charge for rails.....	\$108,835.33	\$203,737.34	\$94,902.01
COST OF TIES.....	171,234.00	326,294.47	155,060.47
COST OF BALLAST.....	29,243.68	34,448.52	5,204.84
COST OF OTHER TRACK MATERIAL.....	96,879.78	99,577.84	2,698.06
ROADWAY AND TRACK LABOR AND OTHER EXPENSES .....	723,779.96	788,989.71	65,209.75
Total charges, Roadway and Track .....	\$1,129,972.75	1,453,047.88	\$323,075.13
Other Charges Account of Maintenance of Way and Structures were as follows:			
SUPERINTENDENCE .....	\$85,365.42	\$89,095.57	\$3,730.15
BRIDGES, TRETTLES AND CULVERTS..	129,298.54	228,478.02	99,179.48
ROAD CROSSINGS, FENCES, ETC.....	45,264.00	54,627.14	9,363.14
SIGNALS AND INTERLOCKING PLANTS	9,245.13	20,629.17	11,384.04
BUILDINGS, FIXTURES AND GROUNDS.	170,543.05	239,467.58	68,924.53
DOCKS AND WHARVES.....	14,651.09	1,043.85	*13,607.24
ROADWAY TOOLS AND SUPPLIES.....	16,399.73	23,742.77	7,343.04
SUNDRY MISCELLANEOUS CHARGES..	83,988.60	98,161.62	14,173.02
Total charges, Account of Maintenance of Way and Structures .....	\$1,684,728.31	\$2,208,293.60	\$523,565.29

\*Decrease.

The foregoing expenditures for maintenance of way and structures for the current year amount to 18.58 per cent of the total operating expenses, as compared with 16.10 per cent for the preceding fiscal year.

**MAINTENANCE OF EQUIPMENT.**

The charges on account of maintenance of equipment for the year ending June 30, 1913, compared with the preceding year, were as follows:

	1912.	1913.	Inc. or Dec.
Locomotives .....	\$783,851.05	\$902,888.58	\$119,037.53
Passenger-train cars .....	213,680.26	263,636.58	49,956.32
Freight-train cars .....	664,352.33	871,933.72	207,581.39
Work equipment .....	25,890.35	33,649.40	7,759.05
Shop machinery and tools.....	31,279.64	29,937.33	*1,342.31
Superintendence .....	58,462.03	59,815.81	1,353.78
Sundry miscellaneous charges.....	19,178.59	27,084.64	7,906.05

Total charges account of maintenance of equipment .....

The above charges for maintenance of equipment for the current year amount to 18.41 per cent of the total operating expenses, as compared with 17.17 per cent for the preceding fiscal year.

**RESERVE FOR ACCRUED DEPRECIATION OF EQUIPMENT.**

At the close of the preceding fiscal year there was a balance to the credit of the equipment reserve accounts of..... \$1,069,073.94  
 During the year ending June 30, 1913, there was credited to the equipment reserve accounts on account of charges to Operating Expenses, Profit and Loss, and for Salvage..... 617,262.57  
 \$1,686,336.51

There has been charged during the year against the above amount the original cost of equipment retired as follows:

10 Locomotives .....	\$84,500.00
2 Passenger-train cars .....	8,700.00
473 Freight-train cars .....	270,423.52
2 Work equipment cars .....	1,400.00
	<u>365,023.52</u>

Leaving a balance to the credit of the equipment reserve accounts on June 30, 1913, of..... \$1,321,312.99

\*Decrease.

**TRANSPORTATION EXPENSES.**

The transportation expenses for the year were \$6,746,791.54, or 56.76 per cent of the total operating expenses. Of this amount \$3,791,898.90, or 56.20 per cent, was for labor; \$2,026,432.05, or 30.04 per cent, was for fuel, and \$928,460.59, or 13.76 per cent, was for supplies and other items.

The total increase in the charges as compared with the previous year was \$463,523.80, distributed as follows:

Increase in amount charged for labor.....	\$186,665.72
Increase in amount charged for fuel for locomotives.....	80,836.20
Increase in amount charged for supplies and other items.....	196,021.88
Total increase .....	\$463,523.80

**CAPITAL STOCK.**

No stock was issued or sold during the year. The company's authorized capital stock is fifty million dollars (\$50,000,000), of which the following has been issued to June 30, 1913:

Common stock and scrip held by the public.....	\$18,559,086.69
Common stock and scrip in treasury.....	2,844,206.64
	<u>\$21,403,293.33</u>
Preferred stock and scrip held by the public.....	\$11,259,911.63
Preferred stock and scrip in treasury.....	1,386,921.66
	<u>12,646,833.29</u>
Total .....	\$34,050,126.62

**FUNDED DEBT.**

At the close of the preceding fiscal year the amount of Bonds held by the Public was .....

Debenture Gold Bonds of 1930, issued during the year for additions, improvements and equipment, were sold, amounting to .....	2,500,000.00
Total Bonds held by the Public June 30, 1913.....	\$37,547,000.00

In addition to the foregoing, Chicago, Saint Paul, Minneapolis and Omaha Railway Company Consolidated Mortgage 6% Bonds of 1880 were issued in exchange for a like amount of the following underlying bonds retired, viz:

Chicago, Saint Paul and Minneapolis Railway First Mortgage 6% Bond of 1878.....	\$111,000.00
North Wisconsin Railway First Mortgage 6% Bond of 1880 .....	31,000.00
	<u>\$142,000.00</u>

There was no change during the year in the amount of Bonds and Scrip in the treasury of the Company.  
 Total Bonds and Scrip in treasury June 30, 1913..... \$51,046.02

**CONSTRUCTION.**

The construction charges for the year ending June 30, 1913, were as follows:

On Account of Additional Main Tracks, viz:	
Balance cost of second track Merrilan to Wyeville, Wis. ....	\$16,078.40
Account cost of second track Truax to Northline, Wis. ....	1,355,368.88
	<u>\$1,371,447.28</u>
On Account of Extensions, viz:	
Balance cost of new line Black River Falls to Levis, Wis. ....	\$1,321.11
Balance cost of double track line from Eau Claire, Wis., west.....	61,784.31
	<u>63,105.42</u>

Sundry Construction:	
Account cost of terminal improvements at Minneapolis, Minn. ....	\$524,255.52
Account cost of terminal improvements at Altoona, Wis. ....	43,507.92
Account cost of Earl St. viaduct, St. Paul, Minn. ....	16,234.67
Automatic block signals.....	258,244.49
Permanent bridges (cost of new over old)....	70,764.32
Strengthening bridges to withstand heavy power	80,094.56
Betterments of roadway and track.....	155,093.27
Sidings and spur tracks.....	56,338.32
Terminal yards .....	28,880.95
Buildings .....	93,133.39
Machinery and tools.....	33,062.47
Miscellaneous charges .....	118,748.65
	<u>1,478,358.53</u>

Equipment:	
Equipment acquired (23 locomotives, 2 steel baggage, 1,000 box, 500 gondola, 100 refrigerator cars, one steam wrecker and one ballast spreader).....	\$1,746,896.41
Improvements to equipment.....	41,412.15
	<u>\$1,788,308.56</u>
Less equipment retired..... Cr.	365,023.52
Total .....	\$4,336,196.27

**SECOND MAIN TRACK.**

The work on the second track between Truax and Northline, Wis., mentioned in last year's report, is well advanced, and the greater part of the track has been laid and 29.65 miles placed in operation. It is expected that the balance of the track will be placed in operation during the month of October, 1913.

**SUNDRY ADDITIONS AND BETTERMENTS.**

Freight and passenger depots at Warren, Osseo, Mason, Barronett and Altoona, Wis., and Mendota, Minn., were replaced by new structures.

Wooden water tanks on steel towers were erected as follows:	
Mondovi, Wis.	Avoca, Minn.
Marshfield, Wis.	Montrose, S. D.
Minneapolis, Minn.	Fulton, S. D.
Merriam, Minn.	Sibley, Iowa.
St. Paul Shops, Minn.	LeMars, Iowa.
	Bloomfield, Neb.

Elevated coal chutes were erected at Knapp and Rice Lake, Wis., Minneapolis and St. James, Minn., and Emerson, Neb.  
 The 30-stall engine house at North Minneapolis, Minn., mentioned in previous report, was completed.  
 The old engine house at Altoona, Wis., (with the exception of five stalls to be used for boiler room and machine shop) has been torn down and is being replaced by a 20-stall structure with turntable; in connection with this work there is being erected a sand house with tower, stand pipe and cinder pit.

An interlocking tower was erected at Northline, Wis., to replace a similar structure destroyed by fire and the interlocking plants at the Eau Claire River bridge and at the C., M. & St. P. Ry. crossing at Eau Claire, also at Camp Douglas, Wis., were remodeled to accommodate the installation of automatic block signals.

Work is in progress on a viaduct at Earl Street, St. Paul, Minn. Automatic block signals between Elroy and Wyeville, Merrillan and Eau Claire, and Northline, Wis. and St. Paul, Minn., mentioned in previous report, were completed and placed in operation.

Automatic block signals are now being installed between Eau Claire and Northline, Wis., a distance of 63.70 miles, of which 32.80 miles were completed and placed in operation July 17, 1913. The balance of the work authorized—30.90 miles—will be completed this year, when the Company will have continuous automatic block signals of the most modern type from Elroy, Wis., to St. Paul, Minn., a distance of 194.57 miles.

Work is in progress on additional yards at Hazel Park and Minneapolis, Minn. The net increase in side tracks and yards during the year was 12.90 miles.

Electric head lights were applied to 138 locomotives during the year to comply with State regulations.

The draw span, 320 feet long, and the fixed span, 157 feet long, of the bridge over the St. Croix River at Hudson, Wis., were replaced by spans

of the same length of heavier construction; and 29 steel bridges between Eau Claire and Elroy, Wis., were replaced with heavier bridges, or strengthened by the addition of material to provide for increase in the weight of locomotives.

The length of wooden bridging was decreased 860 feet, as follows:

By construction of permanent bridges.....	574 feet
By construction of concrete pipe culverts.....	286 feet
<b>Total .....</b>	<b>860 feet</b>

**LAND DEPARTMENT.**

The net receipts from all grants, including Nebraska town lots, were \$7,390.12.

2,939.15 acres were disposed of during the year, leaving 78,644.81 acres unsold June 30, 1913.

Appended hereto may be found statements, accounts and statistics relating to the business of the fiscal year, and the condition of the company's affairs on June 30, 1913.

By order of the Board of Directors.

**WILLIAM A. GARDNER,**  
*President.*

**GENERAL BALANCE SHEET, JUNE 30, 1913.**

1,677.50 Miles.

ASSETS.	LIABILITIES.
<b>PROPERTY INVESTMENT.</b>	<b>CAPITAL STOCK.</b>
Road and Equipment:	Common stock and scrip outstanding.....\$18,559,086.69
Balance to debit of this account June 30, 1912 .....	Preferred stock and scrip outstanding..... 11,259,911.63
.....\$67,749,246.48	<b>\$29,818,998.32</b>
Add sundry construction and equipment expenditures for the year ending June 30, 1913 .....	Common stock and scrip owned by the company .....
4,336,196.27	.....\$2,844,206.64
<b>\$72,085,442.75</b>	Preferred stock and scrip owned by the company .....
<b>Securities:</b>	..... 1,386,921.66
Securities of proprietary, affiliated and controlled companies, unpledged .....	<b>4,231,128.30</b>
206,200.00	<b>\$34,050,126.62</b>
<b>Other Investments:</b>	<b>MORTGAGE, BONDED AND SECURED DEBT.</b>
Advances to proprietary, affiliated and controlled companies for construction, equipment and betterments... 279.98	Bonds outstanding .....
Miscellaneous investments .....	.....\$37,547,000.00
169,229.34	Bonds and scrip owned by the company.....
<b>\$72,461,152.07</b>	51,046.02
<b>WORKING ASSETS:</b>	<b>37,598,046.02</b>
Cash .....	<b>WORKING LIABILITIES.</b>
\$2,413,442.63	Traffic and car service balances due to other companies .....
C., St. P., M. & O. common stock on hand.. 2,844,206.64	.....\$350,488.72
C., St. P., M. & O. preferred stock on hand.. 1,386,921.66	Audited vouchers and wages unpaid.....
Consolidated mortgage bond scrip due from Central Trust Company .....	2,181,466.64
1,046.02	Miscellaneous accounts payable.....
S. S. M. & S-W. Ry. Co. first mortgage bonds on hand .....	117,962.26
50,000.00	Matured interest, dividends and rents unpaid..
Minneapolis Eastern Ry. first mortgage bonds on hand .....	80,227.50
75,000.00	Other working liabilities .....
Minnesota Transfer Ry. first mortgage bonds on hand .....	41,081.77
187,000.00	<b>2,771,226.89</b>
Bills receivable .....	<b>ACCRUED LIABILITIES, NOT DUE.</b>
1,955.83	Unmatured interest and dividends.....
Traffic and car service balances due from other companies .....	\$1,392,197.49
95,908.98	Taxes accrued .....
Net balance due from agents and conductors (including working funds).....	542,122.25
527,102.74	<b>1,934,319.74</b>
Miscellaneous accounts receivable.....	<b>DEFERRED CREDIT ITEMS.</b>
405,573.22	Reserve for accrued depreciation.....
Materials and supplies .....	\$1,321,312.99
1,629,294.89	Unextinguished premium on funded debt sold .....
Other working assets .....	81,251.93
1,655.20	Other deferred credit items.....
<b>9,619,107.81</b>	240,826.71
<b>DEFERRED DEBIT ITEMS:</b>	<b>1,643,391.63</b>
Advances .....	<b>4,592,020.39</b>
\$7,130.08	
Other deferred debit items.....	
501,741.33	
<b>508,871.41</b>	
<b>\$82,589,131.29</b>	<b>\$82,589,131.29</b>

# Railway Age Gazette

PUBLISHED EVERY FRIDAY AND DAILY EIGHT TIMES IN JUNE, BY THE  
SIMMONS-BOARDMAN PUBLISHING COMPANY,  
WOOLWORTH BUILDING, NEW YORK.

CHICAGO: Transportation Bldg. CLEVELAND: Citizens' Bldg.  
LONDON: Queen Anne's Chambers, Westminster.

E. A. SIMMONS, *President.*  
L. B. SHERMAN, *Vice-President.* HENRY LEE, *Sec'y & Treas.*  
The address of the company is the address of the officers.

### EDITORS.

SAMUEL O. DUNN, *Editor.*

ROY V. WRIGHT, <i>Managing Editor.</i>	H. H. SIMMONS	E. S. FAUST
W. E. HOOPER	H. F. LANE	F. W. KRAEGER
B. B. ADAMS	E. A. AVERILL	A. D. CLOUD
E. T. HOWSON	R. E. THAYER	GEORGE L. FOWLER
	A. C. LOUDON	

Subscriptions, including 52 regular weekly issues and special daily editions published from time to time in New York, or in places other than New York, payable in advance and postage free:

United States and Mexico.....	\$5.00
Canada.....	6.00
Foreign Countries (excepting daily editions).....	8.00
Single Copies.....	15 cents each

Engineering and Maintenance of Way Edition and four Maintenance of Way Convention Daily issues, North America, \$1.00; foreign, \$2.00.

Entered at the Post-Office at New York, N. Y., as mail matter of the second class.

Statement of the ownership, management, etc., of the *Railway Age Gazette*, published weekly at New York, N. Y.:

Editor, SAMUEL O. DUNN, Chicago, Ill.  
Managing Editor, ROY V. WRIGHT, New York, N. Y.  
Publisher, SIMMONS-BOARDMAN PUBLISHING CO., New York, N. Y.

### STOCKHOLDERS:

EDWARD A. SIMMONS, New York.	ROY V. WRIGHT, New York.
LUCIUS B. SHERMAN, Chicago, Ill.	ELMER T. HOWSON, Chicago, Ill.
HENRY LEE, New York.	A. C. BOARDMAN, Riverdale, N. Y.
I. B. RINES, New York.	F. BOARDMAN, Riverdale, N. Y.
SAMUEL O. DUNN, Chicago, Ill.	B. BOARDMAN, New York.
	RAY MORRIS, New York.

### BONDHOLDERS:

S. W. DUNNING, New York.	A. B. HENSZEV, Philadelphia, Pa.
FRANCIS BOARDMAN, Committee, N. Y.	C. W. WALTON, Ridgewood, N. J.
S. E. KELLOGG, Newton, Mass.	C. C. NEWCOMB, Brooklyn, N. Y.
W. H. SHUEY, Chicago, Ill.	M. D. HORTON, Brooklyn, N. Y.
CHARLES M. PRATT, New York.	

SIMMONS-BOARDMAN PUBLISHING COMPANY,  
By E. A. SIMMONS, President.

Sworn to and subscribed before Harry E. French, Notary Public for Kings County, N. Y. (No. 12), whose certificate is filed with the County Clerk of New York (No. 8), on September 15, 1913.

WE GUARANTEE, that of this issue 8,350 copies were printed; that of those 8,350 copies, 6,600 were mailed to regular paid subscribers and 344 were provided for counter and news companies' sales; that the total copies printed this year to date were 345,159—an average of 8,629 copies a week.

VOLUME 55. OCTOBER 3, 1913. NUMBER 14.

## CONTENTS

<b>EDITORIAL:</b>	
Editorial Notes.....	597
A Suggestion for Railway Clubs.....	599
Responsibility of Railway Managements for Accidents.....	599
New Books.....	601
<b>LETTERS TO THE EDITOR:</b>	
What Trainmasters, Yardmasters, etc., Can Do to Increase Car Efficiency; by A. Hale.....	602
Trainmen Should Have Homes at Terminals.....	602
<b>MISCELLANEOUS:</b>	
*Double Deck Bascule Bridge.....	603
Society of Railway Financial Officers.....	605
Progress in the Federal Valuation of Railways.....	608
*Steel Frame Box Cars for the Frisco.....	609
Safety First Exhibition of the Pennsylvania Railroad.....	614
Howard Elliott and New England.....	615
*Construction of the Buckhannon & Northern Railroad; by R. E. Kerr.....	617
Report on North Haven Collision.....	619
Connecticut Report on North Haven Collision.....	622
Analysis of a Broken Rail.....	623
*Electric Carrier System.....	624
Signaling Conditions on the Pennsylvania; by A. H. Rudd.....	625
<b>GENERAL NEWS SECTION.....</b>	
	627

\*Illustrated.

AS Arthur Hale suggests in a letter which is published on another page of this issue, the men who can do the most to increase the efficiency of freight equipment are those who are on the firing line. The higher officers are best situated to map out policies and devise methods for improving and correlating the work of those directly concerned with the handling of trains and cars, but the way that the trainmasters, yardmasters, train despatchers, agents and trainmen do their work will determine whether the number of miles moved per day and the number of ton miles handled per day by each unit of equipment will be materially increased. Recognizing this fact, the *Railway Age Gazette*, like Mr. Hale, would like to hear what the men who are constantly on the firing line are doing to expedite the movement of cars and otherwise increase their efficiency. What new methods have you adopted, Mr. Trainmaster, and you Mr. Yardmaster? What results have you got and what suggestions have you to make, the adoption of which would reduce delays to cars, especially in yards and at stations? Your fellow trainmasters and yardmasters, and also the higher railway officers throughout the country, would like to have all the information and all the suggestions along this line that you can place at their disposal. There is no channel through which you can better place your information and suggestions before them than through the columns of the *Railway Age Gazette*, and if you will send them to this paper we shall take great pleasure in publishing them. Not only would what you have to say be of interest and value to others, but what others have to say would be of interest and value to you. There is always profit in the interchange of information and opinions between those who are engaged in the same kind of work and who are anxious to improve the way that they are doing it. The method which you have used to improve conditions may not seem to you either very new or very remarkable, but a description of it may prove interesting, valuable to men occupying corresponding positions on your own and on other railways, and to the higher officers as well.

THE recent arbitration of the wage demands of the engineers of the Chicago & Western Indiana and the Belt Railway of Chicago went against the employees. F. A. Burgess, the representative of the employees on the arbitration board dissented, and in his dissenting report said: "I am strongly of the opinion that the decision of the majority of this board will not settle the question, but simply postpones for twelve months further action. With this thought in mind, together with the knowledge that the findings of the majority of this board will invite severe criticism of the enactment that made it possible to adjust labor controversies in this manner, it is beyond question of doubt that an ultimate crystallization of thought resulting in opposition to this enactment at the national capital is certain to follow." The Erdman mediation and arbitration act was passed in 1898, at the instance of the railway labor brotherhoods. The Newlands amendment to it was passed this year at the instance both of the brotherhoods and the railway managements. Practically every important arbitration under the Erdman act has resulted to the advantage of the employees. When, however, a single arbitration in a relatively unimportant case goes against them, their spokesman finds ground for "severe criticism of the enactment" and sees occasion for a movement for its repeal. Suppose, for the sake of argument, that the result of this particular arbitration actually was unjust: is that a sufficient reason for attacking the law under which it was conducted? The railway managers have thought the results of most of the arbitrations under the law have been unjust; but they have not made that an excuse for complaining at its requirements—except that limiting the number of arbitrators to three, for the correction of which feature the roads and the brotherhoods both appealed to Congress. Some of the labor leaders are very poor sports. They find fault with the rules of the game whenever a game goes



against them, even though they have made the rules themselves. From a long career of success they seem to have concluded that whenever they suffer a reverse the trouble must be with something besides, their case or the way in which it has been presented. What they really want, apparently, is an arbitration law entitled, "An Act to provide that every controversy between common carriers and their employees shall be submitted to an impartial board of arbitration, which shall be composed entirely of walking delegates, and which shall in all cases give the employees all that they demand, with 10 per cent. additional as an honorarium not demanding more."

THE sweet reasonableness characterizing Mr. Burgess' attitude regarding arbitration is fully equalled by that marking the attitude of the Brotherhood of Locomotive Engineers regarding the new rules recently put into effect on the New York, New Haven & Hartford by General Manager Bardo. One of the rules provides that in case of the promotion of engineers or their assignment to special runs "fitness" must be as much a governing condition as "seniority." To a rational mind there does not seem to be anything especially outrageous in that idea. The New England public and the people of the United States are holding the officers of the New Haven to a stern accountability for the collisions and derailments that have been occurring on that road. One of the most certain means of promoting safety in train operation is to promote employees according to their merits, giving to the best men the fastest and most important runs. And one of the best ways to cause accidents is to assign or promote men to runs that they are not fit for. With due regard to its responsibility and duty the New Haven proposes that instead of seniority controlling promotions and assignments due consideration shall be given to fitness. This means, of course, that the management, which is held responsible by the public for results, shall exercise its best judgment in assigning enginemen to runs. Why is the New Haven now under fire? Is it not because people believe that the old management failed to do just this thing? And yet, because the present management insists on considering fitness as well as seniority, the enginemen are taking a strike vote. Can you beat it?

IN the discussion between the railways and the Board of Engineers of the Interstate Commerce Commission regarding the preparation of maps and profiles, it would seem that the representatives of the railways have the better of the argument. The specifications issued by the commission bear a strong resemblance to those under which the valuation work in the state of California is now being carried on. While the railways in that state objected to these specifications, they did not make this an issue. However, when similar specifications are extended over the entire country the objections become increasingly important. The specifications issued by the Interstate Commerce Commission do not appear entirely practical in several respects. In the first place, the preparation of all maps to an absolutely uniform scale, regardless of the fact that this may mean the redrawing of many maps corresponding to the specifications in other regards, places an unnecessary expense upon the railways while gaining a theoretical rather than a practical advantage. It is estimated that the redrawing of these maps will require an expenditure of \$5,000,000, and surely the ordering of an expenditure of this amount by the Interstate Commerce Commission should be carefully considered beforehand. The filing of original tracings rather than blue prints or vandykes with the commission is another point of controversy. Here again the advantages of tracings over vandykes would not seem to justify the increased expense. There is always a tendency of those having the power to order work done at the expense of the other party to require more than when they pay the bills themselves. For this reason, due consideration should be given to the arguments of the rail-

ways. The specifications would appear to be impracticable in that in some instances they require more information upon maps than it is possible to present in a legible form. It would seem that the data regarding the character of masonry foundations, the depth of penetration of piles, etc., could be more properly included in the written description of the bridge accompanying its appraisal. Maps were presented to the commission by various railways illustrating the confusion which would result if all the data asked for in important cities such as New York and Chicago was included on these maps. It is to be hoped that in rendering its decision, the Interstate Commerce Commission will give due consideration to the objections raised by the railway engineers, and will require only such information and maps as are necessary for the proper valuation of the carrier's properties.

DURING April and May, 1912, we published a series of articles on "Defective Box Cars and Damaged Freight," in which the causes of loss and damage to lading from this source were clearly traced, and in each case suggestions were made as to how the defects might be remedied and conditions improved. The statement was made in an editorial on "Defective Box Cars" in the *Railway Age Gazette* of April 12, 1912, page 829, that between 11 and 12 per cent. of the money paid out for freight claims on the St. Louis & San Francisco for the year ending June 30, 1911, was for damage which was directly traceable to defective equipment, and that if it was possible to compute that part of the damage caused by rough handling, robbery and wrecks, which was primarily due to defective equipment, the percentage would be two to three times as great. It was suggested that on this basis the railways as a whole were paying out from \$4,000,000 to \$10,000,000 a year for damage to and loss of freight because of defective equipment. Since the publication of the above mentioned series of articles the Frisco has had 1,000 box cars built in which special precautions have been taken to prevent possibility of pilfering from the cars, or damage to or loss of lading. So well have these features been taken care of that we have found it necessary to go more thoroughly into the details of the design in the article which appears elsewhere in this issue than is our usual custom. It will be seen that the design incorporates features which were used in both the Canadian Pacific and Santa Fe box cars, which were described in the *Railway Age Gazette* of May 10, 1912, as examples of the best steel frame and wooden box cars from the freight claim standpoint—and probably also from the standpoint of cost of maintenance. The design in general follows the outside steel frame cars, first introduced on the Canadian Pacific, while some of the details, including the carlines, follow the Santa Fe practice. Other important details are original with the Frisco, and are based on extensive observations on the part of its officers, who for a considerable time have been giving the problem of freight claims and maintenance of equipment special attention.

THE construction of the Buchannon & Northern, which is described elsewhere marks the entrance of the Pittsburgh & Lake Erie and the Pennsylvania into the West Virginia coal fields, the third owner of the new line, the Baltimore & Ohio, already reaching this district. It also marks the opening for development of a new territory on the west side of the Monongahela river. Aside from these facts, the principal feature of interest in connection with its construction consists in the methods used for overcoming the unusual difficulties encountered from slides. Slides are very commonly encountered on construction work, especially in side hill cuts, and the methods used in dealing with them must depend very largely on the nature of the moving material and the character and inclination of the underlying strata. In many cases in cuts the only thing which can be done is to remove the material back to such a slope that it will remain at rest. Where the slides are below grade on fills and are carry-

ing entire fills out of line, as was frequently the case on the Buchannon & Northern, the problem is more difficult. The dumping of more material on the up-hill side of the fills in an attempt to maintain the alinement frequently increases the movement. The weighting of the toe of the slope by the construction of a berme is frequently effective, but was not practicable here, for the slope extended into the river in many instances. The tremendous pressure exerted by slides of this nature requires that retaining walls, if adopted, be of large section if they are to be effective. Near the south end of the line a wall of this nature was constructed varying from 12 to 26 ft. in height, very little of which showed above the ground after the work was completed. Where it is possible to use it the most successful means of stopping slides of this nature is by bonding the moving material to the strata on which it is sliding. This was done in several instances by breaking up the lower strata by dynamite; and in other instances where the shale was too soft to be shot the strata were bonded together by piles extending through the moving material into the stationary material, and also with horizontal ties, extending into the stationary material.

#### A SUGGESTION FOR RAILWAY CLUBS.

**A.** L. HUMPHREY, vice-president and general manager of the Westinghouse Air Brake Company, made a suggestion to the members of the Railway Club of Pittsburgh, at the September meeting last Friday, which in some form or other could be followed up to advantage by the other railway clubs and railway technical associations throughout the country. The effectiveness of the work of most of the railway clubs is minimized because of a lack of definite aims and policies in preparing the programs for the year; and this is also true to a greater or less extent of many of the other organizations which discuss railway problems. The secretaries, officers or committees, as the case may be, arrange to secure reports or papers from different individuals without reference to any relationship between these papers, or with no definite plan as to the order of their presentation, whereas if some important problem was selected and different phases of it were assigned for discussion at the various meetings throughout the season, with the idea of finally reaching some goal and making definite recommendations to bring about better practices, the work of the clubs would prove of far more interest and value to the membership at large. As it is now, many of the subjects which are selected for discussion are of interest to only a limited portion of the membership, and too often the great majority of the subjects chosen are of special interest to only one class of members—usually the mechanical department officers.

Mr. Humphrey, after directing attention to the fact that the first safety device—the air brake—had been invented and developed in the Pittsburgh district, and that the same thing was also true of the electro-pneumatic semaphore automatic signal, one of the greatest factors in safety work; the solid steel wheel and the steel freight car; and also that the first steel passenger train car was built in Pittsburgh, recommended that the Railway Club of Pittsburgh make a record for itself by being the first organization of its kind to give proper and adequate consideration to the subject of welfare work. Before making this recommendation he described with aid of stereopticon views the very extensive work which has been done along these lines by the Westinghouse Air Brake Company in connection with safety devices in the shops, the education of apprentices and workmen, the improvement in sanitary conditions and the building of homes for the workmen which are furnished to them at a reasonable rental. A much greater amount of this sort of welfare work is being done by the railways and industrial corporations than the general public has any idea of, and Mr. Humphrey's idea apparently was that the discussion of these subjects by the railway club would not only give the public and employees a better comprehension of what was being done, but would enable the railways to compare the re-

sults which are being obtained by various measures which are being tried out, and to improve the work along different lines where some of them may have been weak or have done nothing at all.

While Mr. Humphrey did not specify the various phases of the subject which might be considered to advantage, he undoubtedly had in mind the pension systems which have been in effect on a number of roads for such a length of time that exact statements may be made as to the concrete results which have followed their introduction; the same thing is true of the relief department established on many roads, the railroad Y. M. C. A. movement, the modern systems of apprenticeship training and the developing of workmen, the safety first movement, the measures which have been developed on some roads for protecting the employees from loan sharks, and sanitary measures of various sorts which have been installed to protect both the employees and the public. Other subjects which might also be considered under this head would be the methods of wage payment so as to afford the least inconvenience to the employees, and the possibility of encouraging men to own their own homes. In connection with this latter suggestion, one railway officer has given serious consideration to the formation of loan associations, backed by the railroads, which would enable the men to buy property and build their homes; the services of the railroad company's legal, architectural and storekeeping departments, to be extended to these men so that their homes may be purchased under the most favorable conditions. Several meetings of the club could be devoted to the consideration of these welfare problems with excellent results, and it would then be in a position to make authoritative recommendations on the subject. The other railroad clubs could undoubtedly select equally important subjects which could be discussed and followed up to splendid advantage.

#### RESPONSIBILITY OF RAILWAY MANAGERMENTS FOR ACCIDENTS.

**T**HE report of Commissioner McChord regarding the North Haven collision, an abstract of which is given elsewhere in this issue, deals specifically with this accident alone. The reasoning and conclusions in it may, however, be given an application to the railway accident situation in general, and perhaps Mr. McChord meant that they should be. The first feelings of many railway directors and officers on reading the report may be those of irritation and resentment. Their first impulse may be to criticize Mr. McChord and many of the things that he says. Certainly, both the substance and tone of the document lay Mr. McChord wide open to severe criticisms. He makes some erroneous statements of fact; he refrains from saying some of the things that he ought to have said; and in some cases what he does say is expressed in language scarcely befitting a semi-judicial officer of the government of the United States.

He says that "there were in use (on the New Haven) antiquated signals which were condemned by the locomotive engineman." The locomotive engineman did not condemn the signals, but a signal system that had no distant signals. "With distant signals," the report continues, "the system would be much safer." What might very properly have been said was that in time of fog high speed is absolutely unsafe without distant signals. It is recommended that while a new signal system is being installed between Springfield and New Haven "either distant signals should be provided in connection with all the signals now in use, or the signals should be properly overlapped, or block operators should be located at stations along this line and required to space trains a full block apart." The last recommendation would mean the installation of a manual block system which would keep trains an average of four miles apart. This would be un-

necessary and wasteful, and would introduce a new element of uncertainty, except in times of fog. It is said with reference to Engineman Miller that "officers directly in charge should have kept sufficiently close watch over an engineman performing such service to know absolutely whether or not he was taking proper rest." This is simply one way of saying that officers directly in charge should exercise a surveillance over employees which would be impossible, and which the employees would bitterly resent if it were possible. The recommendation that enough flagmen be provided so that a flagman need never be recalled is a brief and unsatisfactory treatment of a very difficult problem.

Mr. McChord traces the responsibility for the collision up to the directors of the road, whom he sensationally describes as "magicians in the art of finance and wizards in the construction and operation of great systems of railroads." In the last paragraph of his report he says, "An adequate system of superintendence and supervision should be immediately arranged which will give those in authority definite and positive information as to whether or not the safety requirements and rules of this railroad are observed." Having used language regarding the directors of the road which would insure his making the first page of every newspaper in the country, why did not Mr. McChord go farther and say what he meant by "an adequate system of superintendence and supervision"? The only adequate system known, involves the equipment of surprise checking. Did Mr. McChord mean that the New Haven should adopt a system of surprise checking? If he did, why did he not say so? Is it possible that the fact that the labor brotherhoods are known to be opposed to surprise checking prevented him from definitely recommending it? Is it possible that he has more regard for the sentiments and feelings of the "men higher up" in the labor brotherhoods than he has for the "men higher up" on the railroads? The commission repeatedly has betrayed more knowledge of the baleful influence of "wizards of finance" on railroad operation and safety than it has of the influence of labor leaders. Is this another example of the same sort? It is clear that the commission, if it is to assume its share of responsibility and perform its full duty regarding train accidents, needs some of the same tonic medicine which in this report Mr. McChord undertakes to administer to the "wizards of finance."

However, brushing aside these manifest shortcomings of the report, no one familiar with the truth as to this particular accident and the railway accident situation in general can read it without concluding that broadly and in the main its reasoning is based on facts, and that its conclusions are justified. It is the duty of the public and the authorities that regulate railways to let them earn enough and to leave their officers freedom of action enough to enable them to develop and operate the properties along safe lines. It is the duty of the public to pass and have enforced suitable laws to stop trespassing, which is the cause of more than one-half of all the fatalities on railways. But railway directors and operating officers have also a very heavy responsibility and duty. Those, whether "wizards of finance" or otherwise, who allow themselves to be elected to railway directorates assume the responsibility and duty of supervising the entire management of the railway with a view not only to causing profits to be earned for the stockholders, but still more with a view to causing efficient and safe service to be rendered. How are the directors to promote safe operation? Obviously, they cannot directly supervise the work of subordinate officers in the operating department or of employees. But they can and should study the accident figures of their railways as diligently as they study their financial figures, and they can and should select, promote and retire the higher officers even more with reference to the ability which they show to operate the railways safely than with reference to the ability which they show to operate them profitably. Their responsibility and duty in regard to safety is one which neither

the directors of the New Haven nor the directors of most other railways have felt and lived up to.

As to railway operating officers, it is manifestly their duty all along the line, from the presidents down, to select, train, examine and discipline their subordinates with an eye, first of all, to promoting safety. This involves the most thorough and constant investigation and supervision. It requires, with the physical and labor conditions existing on the railways of the United States, the highest degree of energy, tact, patience and courage. Every accident which is caused by dereliction of duty on the part of an employee is an indication not only of a man failure on the part of the employee, but also of man failures on the part of his superiors. It is true, as Mr. McChord points out, that the employees have also their responsibility and duty. It is their duty to thoroughly familiarize themselves with the rules of the railway, to obey rules and orders implicitly and to exercise good judgment in emergencies. And it is the duty of their brotherhoods and grievance committees to discourage, instead of encouraging, carelessness, recklessness and insubordination. But the higher duty of exercising adequate superintendence and supervision, and of administering just but strict discipline, is that of the officers. After all, the employees are likely to be chiefly what their superiors make them; and Mr. McChord is amply justified, in view of the evidence regarding the conditions on the New Haven, in concluding that the operating officers under the former management of that road had not been doing enough to maintain and improve discipline; and there is ample justification for concluding from the evidence regarding the causes of accidents on other railways that the officers of many other railroads also are not doing enough.

It is not sufficient, Mr. McChord indicates, for boards of directors to adopt good resolutions, or for officers to adopt proper rules and deliver general lectures or issue general circulars regarding the duties of employees. And he is right; these things are almost fruitless unless followed up with the detailed instruction, examination, training, checking and discipline which are necessary to insure that the employees know their duties, to ascertain whether they are performing them and to weed out of the service those who do not perform them.

It is essential not only to the safety of employees and the public, but also to the material welfare of the railways themselves, that railway managements and officers, from the directors down, should at once take hold of the accident problem and put forth far greater efforts than ever before to solve it. It is true that the accident situation is not growing relatively worse, as the public appears to think. It is growing relatively better. But the public does not know this. It sees the accident statistics of today and does not compare them with those of yesterday. Consequently, the agitation because of accidents grows in volume and strength; and the only way to deal effectively with it is to reduce the number of accidents. The terrific and irresistible onslaughts which the series of accidents on the New Haven brought down on its former management indicate the kind of attacks that may at any time be directed against any railway management which puts itself in an equally vulnerable position. While the present situation has its dangers, it has also its advantages. Public authorities are beginning to learn that man failures are the main cause of all accidents except those to trespassers, and are beginning to denounce railway managements for not exercising adequate discipline. This would seem to be a favorable time to take the steps necessary to improve discipline. The conditions appear to be ripe for an attack all along the line on the conditions which cause accidents, and it is to be hoped that such an attack will be made on every railway. If it is made not only with the object of punishing employees who are at fault, but also with the object of developing such a system of selecting, training, examining and supervising employees, as will reduce to a minimum the number of them who will make mistakes, it may confidently be expected that the attack will be effective.

## NEW BOOKS.

*Places of Pilgrimage for American Travelers.* Published by the Great Western Railway Company of England.

This is an attractive pamphlet published by the Great Western Railway describing and illustrating a large number of the principal points of attraction in Great Britain for travelers from America. The booklet contains a map showing the principal points and a brief historical sketch in connection with each place. Some of the places described include the birthplaces of several of the early English discoverers or settlers of America and other persons whose lives have been intimately connected with the early history of this country.

*Atlas of Railway Traffic Maps.* By William Arthur Shelton, Instructor in Interstate Commerce, LaSalle Extension University. Size 10 in. x 12 in. Published by the LaSalle Extension University, Chicago. Buckram. Price \$3.

This atlas is one of a series of text books on interstate commerce and railway traffic which is being prepared by the LaSalle Extension University. The series will form the basis of a new course of instruction by correspondence in interstate commerce and traffic management. The purpose of the atlas is to present comprehensive and accurate information concerning the freight rate territories throughout the United States on maps prepared for that purpose. The maps show in colors the classification territories, also the larger freight association and certain rate adjustment group territories, with a complete alphabetical index. The maps have been prepared from current territory directories, information and other circulars and tariffs, and have been carefully checked in several freight association offices, so that the information is as completely up to date as possible. They should be of great value to students of traffic and to shippers.

*Resuscitation.* By Dr. Charles A. Lauffer, medical director, Westinghouse Electric & Manufacturing Company. Bound in cloth. 47 pages. 4 in. x 6½ in. Illustrated. Published by John Wiley & Sons, New York. Price 50 cents.

This book includes a reprint of a paper on this subject delivered by the author before the Philadelphia section of the National Electric Light Association. After explaining a number of successful results which have been obtained by employing resuscitation methods on men who were supposedly dead, the book gives a clear description of the mechanism of respiration, illustrating it by a number of views of various parts of the anatomy. The Prone Pressure or Schaefer method of resuscitation which has been adopted by the National Electric Light Association and a number of other engineering societies is described in detail. It brings out in a clear, concise manner the necessity of people in general being versed in the principles of resuscitation and clearly shows how these principles can be learned so as to prove valuable to persons in ordinary walks of life.

*Edward A. Moseley, The Life Work of.* By James Morgan. New York: The Macmillan Company. Cloth, 378 pages. 5½ in. x 8½ in. Price \$2.

For the last few years of Republican ascendancy in Congress one of the things most often heard of was the "steering committee," of the Senate, the group which really decided legislation, though it had no official authority or function. That term well describes Mr. Moseley's activities. For 20 years or more he was a self-appointed committee of one to steer to successful issue the safety appliance bills and other legislation designed to benefit railway trainmen. Mr. Morgan gives him full credit for originating these laws and getting them passed. The tedious work of instructing the uninformed Congressman and arousing the indifferent could perhaps be done by the legislative agents of the brotherhoods, but for the strategy which, in a hundred emergencies, was necessary to avert defeat, the trainmen were indebted mainly to Moseley. His title was secretary of the Interstate Com-

merce Commission, but that was too tame a job for a man of his energetic, aggressive temperament, and his heart was with the labor unions. He never admitted defeat and he gained his object by sheer perseverance and singleness of purpose. The discouragements of long delays in Congress, which have been the death of innumerable meritorious measures, never baffled him for any great length of time, and he left a number of legislative schemes unfinished when he died, in 1911. Mr. Morgan is a skilful biographer, and as a glorification of his hero's public spirited labors the book must be adjudged a success. Moseley did rough work and often made use of rough means; but it will have to be admitted that in his main purpose he pursued a consistent course.

The first half dozen chapters of this biography make very interesting reading, for its subject had a varied and interesting career before he went from Massachusetts to Washington at the age of 40. It appears that President Cleveland would have made Mr. Moseley a member of the original commission, in 1887, had he not made it a rule never to appoint a Democrat from such a strong Republican state. But he gave the commission a hint to select Moseley as secretary. Thirty pages at the end of the book are filled with appreciations from friends.

*The Railway Library for 1912.* Compiled and edited by Slauson Thompson, Director of the Bureau of Railway News and Statistics. Size 5 in. x 7 in. 467 pages. Cloth. Published by the author, Chicago. Price 50 cents.

This is the fourth edition of The Railway Library, the first of which was issued in 1909, and following the general scheme of its predecessors, it brings together selections from the noteworthy addresses and papers of the year relating to railway subjects. It opens with a brief excerpt from the special American Railway Edition of the London *Times*, followed by the valedictory of James J. Hill to the stockholders of the Great Northern. Railway rates and railway valuation occupy a prominent place in the book, and in addition to several articles which have appeared in the technical press, there is included in full the opinion of Justice Hughes of the Supreme Court in the Minnesota rate case.

The problem of safety in railway operation and service receives attention in several articles. Railway nationalization is discussed in the abstract, and also with reference to the concrete examples afforded by Australia and France. The remuneration and hours of railway employees in Germany and the United Kingdom are exhaustively treated, and the various phases of compulsory arbitration are set forth in an animated discussion in the "Societe d'Etudes Legislatives," Paris.

Articles relating to the accident situation on American railways include an article from the *Railway Age Gazette* on "Why Five Thousand Trespassers are Killed Yearly"; an article showing the classification of trespassers killed on railways by Frank V. Whiting, general claims attorney of the New York Central Lines, and an address on the work of the federal government in the prevention of railroad accidents by Commissioner McChord of the Interstate Commerce Commission. Other articles include "The Country's Need of Greater Railway Facilities," by James J. Hill; "Adequate Service and Facilities Obligatory," by C. A. Prouty of the Interstate Commerce Commission, and "Are We Ready for Industrial Co-operation?" by Fairfax Harrison, president of the Chicago, Indianapolis & Louisville. A description of the new passenger terminal of the New York Central is included to illustrate the enormous cost of modern terminals. For the purpose of comparison of conditions in this country there are a number of articles on foreign railways written by some of the leading authorities in the various countries, including "Government Railway Operation in France," by Paul Leroy-Beaulieu; "Average Pay of German Railway Servants," by Professor Lotz of Munich; "Earnings and Hours of English Railway Servants," from the Bulletin of the International Railway Congress.

## Letters to the Editor.

### WHAT TRAINMASTERS, YARDMASTERS, ETC., CAN DO TO INCREASE CAR EFFICIENCY.

CHICAGO, September 12, 1913.

TO THE EDITOR OF THE RAILWAY AGE GAZETTE:

I am very glad to see from the evidence which you are printing that the question of getting more movement of our freight cars is a live one with our presidents, our general managers, and our superintendents, but I confess I should like to see something from the men who are really closer to the work. The most important fact which I realized when I was a general officer of a railroad was that I could not do anything absolutely by myself, and that the men "on the road" could do a great deal, and, indeed, were doing a great deal, without the help of the general officers.

The railway officers who have written you on this subject will be the first to agree that they are getting more movement out of their freight cars because they have the cordial co-operation of the men on the road—the trainmasters, yardmasters, agents and train men.

I would like to hear from the best men on the road what devices they are adopting to get more movement out of the cars. A good idea from one of them given the publicity of your columns will bring forth seed a thousand-fold.

E. H. DeGroot, Jr., is right in saying (in *Railway Age Gazette*, September 5, page 403) that a great deal can be done at local freight stations. There is not a freight agent who cannot help to better the movement by economizing in his orders for cars, by making sure the cars are loaded in time for the local, and in a hundred other ways.

Local train crews can help a great deal. I shall never forget the complete organization of a local switch crew on the Pennsylvania Railroad some thirty years ago, with which I had the honor of being temporarily connected. The conductor of that crew knew the location of the switches at each station thoroughly, and gave specific orders to each member of his crew before approaching a station, so that the work was done with remarkable efficiency. Not only did this conductor give his orders clearly and ahead of time, but he insisted on getting his own orders in such definite shape that he, himself, knew exactly what was to be done at each station before he approached it. That crew earned thousands of dollars a year by its efficiency in getting more movement out of cars.

The road foreman, supervisors and section hands can help get more movement out of cars, not only by insuring the cars a perfect highway, but by doing their work so that the ordinary movement will be interfered with as little as possible.

The master mechanic and roundhouse foremen can help, not only by seeing that the equipment is in good shape, but by seeing that it is put in good shape without fail when it is needed.

Probably the yardmaster can help most. A good yardmaster knows that a yard is a place to get cars out of, while a poor yardmaster thinks of it as a place to get cars into. I would like to know how the best yardmaster manages to get cars through his yard quicker this year than he did last. He must have a thousand devices, while I only know a few, that would help the situation if adopted by other yardmasters of less experience.

Of course the train dispatchers can help, especially those train dispatchers who distribute cars at local stations. Some of them could tell us how they so arrange it that cars shall reach the points where they are needed exactly when they are needed, and are moved again immediately after loading.

The trainmaster could tell us how he co-ordinates the work of his dispatchers, his yardmasters, his train crews, and his agents.

Letters of this kind would, perhaps, not be as well rounded out as those that have been written to you, but to my mind

they would be of more value, and hints as to improvements from these men on the firing line would help the others who are actually engaged in the work of getting more movement out of freight cars.

A. HALE,

General Agent, American Railway Association.

### TRAINMEN SHOULD HAVE HOMES AT TERMINALS.

CHICAGO, Ill., September 18, 1913.

TO THE EDITOR OF THE RAILWAY AGE GAZETTE:

In the reports as to the recent accident at North Haven, Conn., I notice that Engineer Miller had actually been getting very little real rest on account of deadheading back and forth between Stamford and New Haven during his hours off duty, his home being near New Haven and his run starting from Stamford. While this may have had nothing whatever to do with this particular accident, there is no doubt that an engineer—or any other employee connected with the operation of trains—needs at least the amount of sleep and rest prescribed by the laws of nature in order to be in sufficiently good mental and physical condition to be entrusted with the care of a railroad train. In the case of a night run when it is natural to sleep, adequate sleep and rest is all the more important.

In Miller's case there seems to have been ample time to have secured sufficient sleep had he lived at Stamford, but his home being near New Haven he naturally elected to go home, the result being that in the 24 hours prior to the accident he actually secured about three hours' real sleep—I hardly see how he could have gotten more.

Is it not an entirely reasonable proposition that a man should live where his work is? In the case of a man in train service assigned to a regular run should he not be required to live where the long layover is and where he can secure proper rest? It does not seem that any reasonable and fair minded man or body of men could consistently oppose such a requirement. The officers of the railroads, being semi-public officials, should see that this is done, as both the railroads and the men have a duty to the public to perform in seeing that all men put in charge of trains are in first class condition, both physically and mentally. The railroads should first see that the different runs are so arranged as to be as comfortable as they can be made under the conditions as they exist, and the men accepting such assigned runs should be required to live where they can secure natural rest. This may present some difficulties on roads which run a large number of additional passenger trains during certain seasons of the year, but such difficulties could and should be overcome.

On one of our western roads recently a superintendent found that some of his men assigned to way freight service were living at the opposite end of the run from where they arrived Saturday night, the result being that they were riding both Saturday and Sunday nights in order to be home Sunday and return to the starting point of their run Monday morning. This practice was promptly stopped, with beneficial results.

EMPLOYEE.

RAILWAY ACCIDENTS IN THE UNITED KINGDOM.—According to returns made to the British board of trade, 284 persons were killed and 2,457 injured on railways in the United Kingdom during the first three months of this year—an increase of 39 killed and 268 injured on the record for the corresponding quarter of 1912.

NIGERIAN RAILWAYS.—The sanction of the Imperial Government has been given to the details of an important railway scheme for the further development of Nigeria. The terminal point of the line, which will be some 400 miles in length, and will probably take three years to construct, has been fixed at Ignooha, at the head of the Bonny estuary. Construction on the new line will be started without delay and pushed forward as rapidly as possible.

# DOUBLE DECK BASCULE BRIDGE.

The Problem of Building a Double Deck Bascule Bridge Solved Without Adding a Single Extra Detail or Joint.

The bascule bridge recently completed by the Canadian Pacific over the Kaministiquia river at Fort William, Ont., to reach the coal dock and piers on Island No. 1, is the first double deck bascule bridge in the world. It is a single leaf Strauss trunnion bascule structure carrying a double track railway on the lower deck and a 29-ft. highway and two electric railway tracks on the upper deck. It consists of a 186-ft. river or movable span, pin-connected at the main trunnion T. Fig. 2, and resting on an ordinary truss shoe on the rest pier R. The details and the general arrangement of

the angular movement of the counterweight is equal to that of the movable span, which, as will easily be seen, is the only necessary condition for perfect balancing in all positions, if the bridge be perfectly balanced when closed, and if a line T D from the main trunnion to the center of gravity of the movable span be parallel to a line C E from the counterweight trunnion to the center of gravity of the counterweight (including counterweight trusses, etc.), due allowance being made for the weight of the links and the operating struts. If these conditions are fulfilled, the composite center of gravity of the entire structure will not move either vertically or horizontally as the bridge goes up and will always fall between the two tower piers. It will thus be seen that the dead load reactions on these piers remain vertical and constant at all times, which is one of the characteristics of the Strauss bridge.

The bridge is operated by two 85-h. p. General Electric motors "ITC 5014," which are located on the movable span under the highway floor at F, and are controlled from the operator's house, which is supported on the tower. They operate a train of ordinary spur gears, which terminate in

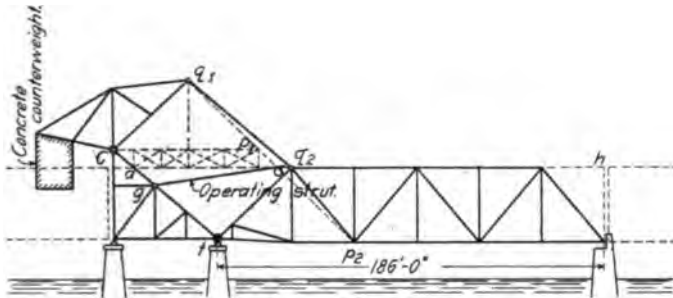

Fig. 1.

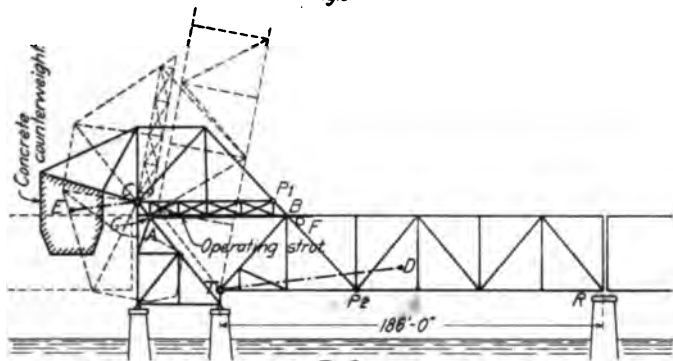

Fig. 2.

Figs. 1 and 2—Diagrams of Calumet River and Kaministiquia River Bridges.

trusses, floor system, bracing, etc., conform with standard practice in the design of stationary bridges for similar service. It further consists of a 40-ft. tower span having four triangular trusses, two in line with the bascule trusses and two placed 15 ft. outside of these, the tower trusses being surmounted by four counterweight trusses, pin-connected to the tower trusses at C, which support two concrete counterweights, so placed as to permit the traffic on the upper deck of the approach span to pass between them. On account of the limited space in which to place the counterweights, iron ore was used in the concrete, of which the counterweights were made, to secure as great a density as possible. The resulting concrete weighs about 175 lbs. per cu. yd. The four tower trusses as well as the four counterweight trusses are thoroughly braced transversely by means of cross braces and portal struts.

From A to B the inside counterweight trusses carry the floor system of the upper deck, while the counterweight trusses are connected to the bascule span by means of two structural steel "links" P1-P2, placed in a transverse direction centrally between each pair of counterweight trusses on both sides of the bridge, connecting a pin at P1 to a cantilever pin of large proportions at P2.

It will be noted that the four pins, T, C, P1 and P2, are located in the corners of a parallelogram, and this remains true for any angle of opening of the bridge, insuring that



Fig. 3—Erecting Double Deck Bascule Bridge in Open Position.

two steel pinions, which in turn engage cast steel racks bolted to the underside of two structural steel operating struts, which are pin-connected to the tower at G. It will thus be seen that the movable span, so to speak, operates itself, but in later designs the machinery is often placed in the tower and the conditions reversed, which has several advantages, although the former arrangement is equally efficient as far as the operation of the bridge is concerned. The total weight of steel in the bridge, exclusive of approaches, is about 2,500 tons and the counterweights weigh about 2,400 tons.

Fig. 3 shows a photograph of the bridge during construc-

tion, and it will be noted that the bridge is being erected in the open position so as not to interfere with river traffic, a procedure which is common in work of this kind, and which has proved to offer no particular difficulty, but rather to be



Fig. 5—Canadian Pacific Double Deck Bascule Span in Open Position.

economical and convenient. In this view the first two panels of the movable span are erected, one of the concrete counterweights and one of the counterweight links have been com-

pleted, and the holes in the bascule truss and in the link for the lower pin (P2) can readily be seen.

It is interesting to note that the problem of building a double deck bascule which at first would seem impossible without one floor fouling the other, or without placing the break in the floor back of the point of rotation, has here been solved in such a manner that the structure does not contain a single extra detail or joint as compared with the standard heel trunnion design. The evolution from the ordinary single deck railway bridge to the double deck structure has been indicated in Figs. 1 and 2, which show to correct scale skeleton drawings of the Chicago & Western Indiana Calumet river bascule and of the Kaministiquia river bridge.

Both bridges have movable spans of 186 ft. and it will be noted that by adding the members indicated in dotted lines in Fig. 1 by moving the "link" from q1-q2 to p1-p2, and by placing an additional deck on top of the movable span from q2 to h and at the bottom chord of the extended counterweight trusses from a to q2, the bridge is changed from a single deck to a double deck structure, operating as a unit, and identical in principle with the single deck bridge in every respect. The most important difference lies in the dividing of the counterweight into two separate halves and the placing of these outside the bascule trusses, as referred to above, but this has been done also in a few single deck structures in order to keep the tower and the counterweight low, and is therefore not peculiar to the double deck bridge.

The type of the Kaministiquia river bridge and the general lines of the structure were determined by C. N. Monsarrat, former bridge engineer of the Canadian Pacific, while the drawings have been prepared under the direction of the present bridge engineer, P. B. Motley. The design was worked out and the general detail drawings were prepared by the Strauss Bascule Bridge Company, of Chicago. It was fabricated and erected by the Canada Foundry Company, Ltd., Toronto, Ont.

**NEW FREIGHT CARS FOR INDIA.**—During the quarter ended March 31 last the number of new freight cars put on the line by the principal railways was as follows: East Indian, 333; North-Western State, 220; Bombay, Baroda & Central India, 194; Bengal-Nagpur, 150; Great Indian Peninsula, 109; South Indian, 70; Eastern Bengal State, 48—all 5 ft. 6 in. gage; and the Bengal & North-Western put in service 754 new 3 ft. 3 in. gage freight cars.



Fig. 4—New Double Deck Strauss Bascule Span over Kaministiquia River.

# SOCIETY OF RAILWAY FINANCIAL OFFICERS.

## Security Market Conditions, Voucher Forms, Clearing House Settlements and Semi-Monthly Payment Discussed at Meeting.

The seventh annual meeting of the Society of Railway Financial Officers was held at the Hotel Moraine, Highland Park, Ill., on September 23, 24 and 25, and was attended by 41 members. The meeting was called to order on Tuesday afternoon by President T. H. B. McKnight, treasurer of the Pennsylvania Lines West of Pittsburgh.

### PRESIDENT'S ADDRESS.

Mr. McKnight presented the annual address of the president, reviewing the principal events of the past year, and dwelling particularly on the increasing difficulty that railways have found in borrowing money at reasonable rates for refunding obligations, and for new capital expenditures until companies whose credit is unexcelled are borrowing money at 5, 5½ and even 6 per cent. Among the reasons for this condition he mentioned the reduction in the saving power of the people, owing to the high cost of living and the higher standard of living, vast increases in the amount of bonds issued by railways to provide for increased business, increases in the number of corporations issuing securities, and the new obligations poured out by states, counties and cities for all manner of improvements, the increase in interurban and city electric lines, electric plants, etc. Manufacturing corporations of all kinds, he said, from small companies to the trusts, vie with each other in flooding the market with their mortgage obligations. The result of all this borrowing means that bonds are sold by agents like life insurance, each offering a more attractive investment than the other until the low-rate but well-secured railroad bond has no chance at the market. He also mentioned the war in the Balkans and the mobilization in all European countries which have lessened the market abroad for American securities, the evident hostility in legislative bodies to railways, and the decreased value of gold. Short term notes recently issued by the railroads have decreased the market for long time securities.

Regarding the plan for the establishment of a general railway clearing house which was recommended by the executive committee last year, he said that the local clearing house established at Chicago during the year as an experiment has now been in operation for such a time as to prove the practicability of clearing adjusted balances, and it will soon be time to take up the subject again with the accounting officers with a view of getting a general railway clearing house established. He believed the accounting officers were now prepared to favor the plan whenever it appears advisable.

### CLEARING HOUSE SETTLEMENTS.

Secretary Carl Nyquist, assistant secretary of the Chicago, Rock Island & Pacific, presented the report of the secretary and treasurer, showing that the financial affairs of the association are in a favorable condition, and that the membership stands the same as it was last year, 118 members, resignations and deaths having been offset by new members. He then presented the report of the executive committee outlining the progress made during the year in carrying out the recommendation of last year's committee, looking to the establishment of a general railway clearing house. Sub-committees of six members each, representing the financial officers and the Association of American Railway Accounting Officers, had conferred on the subject and unanimously adopted a resolution favoring the principle of clearing house settlement for all agreed balances, and recommending that the plan be tried out by railways having headquarters at Chicago, in order that the experience thus gained might be used in determining the practicability of organizing a general clearing house. The present Chicago clearing house is settling ticket and per diem balances for seven roads, and is working satisfactorily. There is no expense connected

with it, as each road reports its balance monthly to the chairman, who makes the necessary computations, and advises the treasurer of the road which he represents (at present the Chicago, Rock Island & Pacific), who acts as treasurer of the clearing house and draws for all debit balances, advising all creditors to draw on his road. In other words, the accounting and cash for all roads in the local clearing house are handled practically as the business of the road acting as chairman. The scheme is very simple and could readily be extended to cover freight balances when the roads agree to it.

### FORMS OF VOUCHERS.

J. G. Stidger, treasurer of the Wheeling & Lake Erie, presented a progress report of the committee on forms of vouchers and agents' drafts. Letters have been sent to each member of the association and to a large number of other roads asking for samples of their voucher forms, and inquiring as to whether they had adopted the standard form recommended by a previous committee, to be negotiable, in the form of a straight check or draft, on which the endorsement of the payee is the only receipt required, of a standard size, 3½ by 8½ in. The replies, while not complete, showed that many roads have adopted forms similar to that recommended. Variations from this form were discussed in the report, and it was stated that those roads which had adopted the standard have found it a great time-saver, particularly for the reason that it does not permit the clerks to copy so much information from the bills. A committee of the American Bankers' Association had objected to any form of folded voucher because of the chance of mislaying small checks between the folds. While railways cannot use the small form for all of their business the committee believed it to be adapted for over 80 per cent. of their business.

The report brought out a lively discussion, which showed that several roads have found the uniform small voucher suitable for from 80 to 98 per cent. of their business. No information was presented as to the number of companies that have adopted it, but one member reported that 80 roads with which his company deals are using it, and that a bank president had told him the voucher check was becoming so popular he was considering getting up a form to recommend to his customers. Another member pointed out that this form obviated the necessity of depending on a clerk to properly match the checks with vouchers ready for signature. A resolution was adopted reaffirming the previous recommendation of the standard form.

### PAYMENT OF DRAFTS.

The secretary read a paper by R. R. Reed, assistant treasurer, Pennsylvania Lines, on "An Efficient and Satisfactory Method of Payment of Drafts by Drawees." Previous to 1904 there was a continuous stream of drafts being presented by various banks to the treasury departments of the various subsidiary companies of the Pennsylvania system throughout the day. In that year a plan was adopted by which one bank would accept each morning at the clearing house all drafts drawn upon the various treasury department offices of the Pennsylvania Lines, amounting to 500 or 600 a day. The drafts were listed on an adding machine and taken to the treasuries by 11 a. m. They were there checked and those requiring approval by the accounting department were checked at once by representatives of that department, and checks for the total amounts were drawn by the various cashiers of the subsidiary companies for all drafts which had been accepted and were to be paid, the checks being delivered to the bank by 3 p. m. This plan has resulted in a great saving of time and requires only one check each day for each company in the system.

The discussion on this paper showed that similar methods are



practiced in many large cities, but that the New York banks are not willing to adopt it. In one city the clearing house charges all drafts to one bank and the road gives one check for the entire amount.

S. L. Shannon, treasurer and comptroller of the Canadian government railways, read a paper discussing some phases of the financial affairs of those roads. All revenue collected goes into the public treasury, and is not drawn on directly for the expenses of operating the roads. Parliament appropriates annually the amount necessary for operation, as well as that required for capital account. The Canadian government, the provinces and the municipalities have made free gifts to aid in the construction of railways, amounting to \$131,256,136, up to the end of the fiscal year 1912, in addition to \$285,423,555, representing the cost of railways constructed or under construction by the government.

D. K. Kellogg, treasurer, Richmond, Fredericksburg & Potomac, presented a paper on "Why Should State and Federal Governments Be Liberal in the Treatment of Railroads?"

#### CASH BOOK SYSTEMS.

John E. Murphy, treasurer of the Chicago & Western Indiana, read a paper describing a plan recently adopted by his road for furnishing cash book information to the auditor. This consists of a loose leaf cash book in which entries are made by typewriter and a carbon copy is furnished to the auditor so that the original book need not leave the treasurer's office. He also described a new form of negotiable time certificate, called a department pay roll draft, which is used for the payment of employees leaving the company.

The paper aroused an interesting discussion on various methods of cash book procedure and particularly on the advisability of using loose leaf books. It appeared that ten roads of those present use the loose leaf system for cash books, but others doubted their legality if required to be produced as evidence in court. A resolution was adopted providing for the appointment of a committee of three to inquire into the advisability and legality of loose leaf systems for all treasurers' records, to report at the next meeting. The president appointed on this committee W. Hodson, assistant treasurer, Chicago, Rock Island & Pacific; R. P. Ahrens, local treasurer and assistant secretary, Lake Shore & Michigan Southern, and John E. Murphy, treasurer, Chicago & Western Indiana. The discussion on the time certificate showed that many of the treasurers preferred a non-negotiable order for discharged employees.

#### SEMI-MONTHLY PAY LAWS.

R. W. Morrison, assistant to the treasurer of the Pennsylvania Lines, presented the following paper on "Semi-Monthly Pay Laws."

The legislatures of a number of states last winter enacted laws requiring individuals, firms and corporations to pay their employees twice each month.

The bills requiring this frequent payment were advocated and pressed by representatives of organized labor, although in some states the impression prevailed that the merchants' associations were also aiding the measure. Careful investigation failed to show, however, that they were, at least openly, taking any part in the movement.

Public hearings were held to consider the bills, and the railroad companies were represented and made a vigorous fight to defeat the measures, but they did not receive assistance from other corporations. Although the only advocates of the measure appearing before the committees were the representatives of organized labor, the arguments of the railroad companies were attacked not alone by the representatives of organized labor, but also by members of the committees themselves.

The principal reasons given by the advocates of the bill were: First, that it would reduce the high cost of living, as the employees, by receiving their money twice a month, could pay cash for what they purchased, and thereby receive more for

their money. Second, that the employee would not be compelled to go to the loan sharks when he wanted money. Third, that it would compel roads to pay more promptly, as under the monthly pay system a number of roads did not pay until the twentieth or twenty-fifth of the month the wages earned in the previous month, and that there was no reason for it except that the roads were getting interest on the money which belonged to the employees.

The representatives of the railroads argued that as all credit was on a 30 day basis, there would be no advantage to the employee, and that the plan would have a tendency to make the employee improvident; that the additional cost of paying twice a month would be increasing the burden of the railroads and that there would not be a corresponding benefit to any one.

The laws, however, were passed in many states.

The provisions of the laws are similar in most of the states. They agree on the division of the month, the first to the fifteenth inclusive, as the first half, and the sixteenth to the last day inclusive, the last half. There is, however, a difference in the time when payments are to be made, and some states have prescribed the medium to be used.

New York requires payment twice each month in *cash*.

Pennsylvania requires that unless otherwise stipulated in the contract of hiring all employees other than those receiving an annual salary, shall be paid semi-monthly.

Ohio requires all employers who shall employ four or more regular employees to pay employees semi-monthly; provided, however, that if an employee shall be absent from his regular place of labor and does not receive his wages through a duly authorized representative, he shall be entitled to payment at any time thereafter upon demand upon the proper paymaster at the place where such wages are usually paid and where such pay is due.

Indiana requires payment to employee between the first and tenth, and between the fifteenth and twenty-fifth of each month, all wages earned to a date not more than ten days prior to the date of such payment.

Illinois requires that every corporation for pecuniary profit engaged in any enterprise shall pay as often as semi-monthly to every employee all wages earned to a day not more than eighteen days prior to the date of such payment; provided that if an employee is absent at the time fixed for payment or for any other reason is not paid at that time, he shall be paid thereafter at any time upon six days demand.

Michigan requires persons or firms engaged in manufacturing, corporations, contractors and others, to pay their employees semi-monthly; any employee leaving his employment between the dates of any established pay-day, shall be paid the wages due at the time of leaving, or the next regular pay day, but any employee discharged or absent on such regular pay day, shall be paid forthwith after demand, as soon as the amount due can with the utmost diligence be ascertained, provided, that the mailing of a check upon or before the regular pay-day shall be deemed to be a compliance with the act.

Missouri requires that all corporations employing mechanics, laborers or other servants, shall pay the wages of such employees as often as semi-monthly.

When the semi-monthly pay laws were enacted it at once became evident that it would be necessary to use every means possible to assemble the time and prepare the pay rolls more promptly, to enable checks to be drawn and forwarded for delivery within the time allowed, or to make payments in cash where that medium was used. As the work was practically doubled it became necessary to increase the timekeeping force as well as the force for preparing and delivering the checks or cash, thereby increasing the expenses of the railroad company. And this increase of expense apparently gave the members of the legislatures not the least concern.

No doubt every treasurer has experienced more or less trouble by delays in receiving the pay rolls from the accounting

department, owing to the fact that a force necessary to take care of the ordinary business is not sufficient to take care of the overflow which comes with the pay rolls, so that with payments twice a month these troubles are doubled.

There are two solutions of this problem: one is to have a floating force which can be drawn from other offices at pay roll time to assist in getting the rolls through the auditor's office promptly. This has its objections, owing to the fact that it causes congestion in one office, but this may not be so objectionable when checks are to be drawn after the rolls reach the treasurer. It is a serious objection when payments are to be made in cash.

The other plan is to have the accounting department send men to the important points to audit the rolls as they are prepared and turn them over to the paymaster for payment.

At terminal points there are a great many rolls, such as those for shops, freight stations and yards, that can be prepared before the time slips of the trainmen are received, and these can be delivered to the paymaster for payment on the third business day, other rolls to follow as they are completed, so that it is possible without much effort to have all rolls in the paymaster's hands by the fifth business day.

The preparation of trainmen's rolls are the most difficult, owing to the various rates of pay and overtime, but a great deal of the delay caused by having to make all the calculations after the time is placed on the check roll can be obviated by using a time report on which is calculated each day the earnings of the employee for the trip and overtime, the amount to be entered on a wage sheet.

The wage sheet is ruled horizontally for the days of the month, and vertically for the employee whose name appears at the top of the column, so that closing the rolls becomes a question of addition which must be done by the old method, so that the time saved is that which is required to make the calculations of the various trips by the rate.

My experience with the semi-monthly pay is limited to a short period, but if the expressions of disapproval we hear from the employees mean anything, I am inclined to the opinion that the advocates of the law were wrong in their ideas of the benefits they would receive and the railroad companies more nearly right in their prediction of the results.

A. B. Jones, local treasurer, Chicago & North Western, presented a short paper on the same subject.

In the discussion that followed several members related their experiences before the legislative committees in opposing the semi-monthly pay laws, and told how the laws have increased the working expense in their departments. It was brought out that one company had found it cost an average of 20 cents to pay a man once a month, and that the additional cost to pay him twice a month was about 12 cents. In most cases the paymaster's forces had been doubled and additional forces had been required in other departments. Some roads had adopted the semi-monthly pay day all over the system as soon as the laws had been passed in one or two states, and had kept the expenses from being doubled by systematizing their arrangements for paying the men. One company makes out its pay rolls in duplicate by the use of carbon paper, printing an extra column on the second sheet for the second half of the month, so that the only additional work in making out the pay roll for the second two weeks is in filling in the amount, the name and other information having been written at the time the roll was made up for the first two weeks. Several members believed that the length of time required on some roads in the past, to pay the men after the expiration of the month, was partly responsible for the agitation for semi-monthly pay laws, and while many declared that the railways may as well prepare to have such laws passed in all states, and to meet the condition that will be imposed, a large number thought that the majority of the men do not want to be paid semi-monthly, and that the passage of the bills was almost entirely due to labor leaders and legislators

who wanted to pass laws they thought would be popular with the employees. On one road the date of payment was changed from the 20th to the 15th of the month, and the men seem to be satisfied, and no state through which this road passes has enacted such a law. Several members opposed the laws not only on the ground of increased expense to the railway, but because they believed the men were better off under the monthly system of payment, on the ground that all credit is on the 30-day basis, and that a monthly payment system tended to cultivate relations with the banks.

Frank J. Loesch, local attorney of the Pennsylvania Lines in Chicago, presented a paper on "Railroads from a Legal Aspect," which will be printed in these columns next week.

#### SECURITY MARKET CONDITIONS.

The secretary read a paper by J. V. McNeal, fourth vice-president and treasurer, Baltimore & Ohio, on "Present Condition of the Security Market, Its Cause, Effect and Probable Duration." After discussing various causes for what he termed the "crisis of 1913," he said "nothing to my mind encourages the contemplation of a reduction in the rate of interest on property such as we are concerned in, or the securities issued for their development, as long as they are fair targets for taxation, and so long as they suffer from this high cost of living, but are restrained from participating in the defenses against it enjoyed by all others. It may be possible, and no doubt is, that great improvements could be made in the management and operation of these properties. I know of no phase of humanity that could not be improved, but this very attitude of the law making and law administering power toward these railways is repellent to the investors seeking their securities rather than encouraging to them. I am not without faith that this condition will give way to something that will permit the railways to earn such a wage in the way of interest returns to those holding their shares as will permit them to meet the public desire in all respects as public utilities should."

The secretary also read a paper by Frank Scott, treasurer of the Grand Trunk, on "The Financial Situation in Canada."

An interesting discussion ensued on the condition of the security market. Various reasons for this condition were assigned, chief among them being that other industries and public works are absorbing large amounts of capital, at rates far beyond what the railways can afford to pay and with almost equally good security. Many thought that there is a present tendency toward improvement, and it was stated that the railways are only awaiting more favorable conditions to seek large amounts of new capital for improvements.

No formal report was presented on the question of clearing house settlements. Mr. Hodson added some information to that contained in the report of the executive committee on the working of the local clearing house at Chicago, in which the Atchison, Topeka & Santa Fe, Chicago & Alton, Chicago, Burlington & Quincy, Chicago Great Western, Chicago, Indianapolis & Louisville, Chicago, Rock Island & Pacific and Illinois Central are the members. The accounting departments furnish the figures and the chairman makes up drafts on the different roads. When paid these amounts are taken into the cash, the other roads are notified and they draw on the Rock Island through the banks. After discussion a resolution was adopted as follows:

Resolved, that we reaffirm our belief in the clearing house scheme and desire the full establishment of a general railway clearing house as soon as it can be brought about, and urge the executive committee to proceed in the matter at its discretion.

A discussion of questions in the question box concluded the Wednesday session, and on Thursday morning the election of officers was held, which resulted as follows: President, George A. Walker, assistant treasurer, Pennsylvania Railroad, Philadelphia; first vice-president, John E. Murphy, treasurer, Chicago & Western Indiana, Chicago; second vice-president, D. K. Kellogg, treasurer, Richmond, Fredericksburg & Potomac; secretary and treasurer, Carl Nyquist, assistant secretary, Chicago, Rock

Island & Pacific (re-elected). New members of the executive committee: J. G. Stidger, treasurer, Wheeling & Lake Erie, Cleveland; George A. Walker, John E. Murphy, E. H. Alden, secretary and assistant treasurer, Norfolk & Western, Philadelphia, Pa., and D. K. Kellogg.

A resolution was also adopted at this session providing for the appointment of a committee to endeavor to increase the membership and the attendance at meetings.

The entertainment program included an informal tea at the Skokie Country Club and an automobile ride to the United States Naval Training Station for ladies and guests; and for members and guests, on Tuesday evening dancing and cards; on Wednesday evening a dinner, reading and music, and on Thursday afternoon and evening an automobile ride through Chicago's parks and boulevards, and a theater party.

## PROGRESS IN THE FEDERAL VALUATION OF RAILWAYS.

Substantial progress is being made by the Board of Engineers of the Interstate Commerce Commission in charge of the federal valuation of railways and the committee of 15 engineers representing the railways in arranging many of the preliminary details with reference to this proposed work. These two bodies have been in frequent session throughout the summer and are reaching a common understanding on many important matters. The practice of the Board of Engineers now is to endeavor to decide many of the fundamental rules of practice with the committee of railway engineers.

The question which has been the subject of the most controversy up to the present time has been that of the preparation of maps and profiles for the use of the commission's engineers. Tentative specifications for maps and profiles were issued by the Interstate Commerce Commission at the suggestion of the Board of Engineers about August 10. These specifications provided in brief that drawings should be divided between right of way and track maps, station maps and profiles. All maps and profiles are to be made on the best grade of tracing cloth. The right of way and track maps are to be made in sheets 24 in. by 56 in. on the scale of 1 in. equals 400 ft. Station maps to a larger scale are required wherever sufficient information cannot be clearly shown on the right of way and track maps. In large cities the station map is to be made in two sections, one showing details regarding land and the other regarding track and structures. Station maps are to be made on the same size sheets as the right of way map and on the scale of 1 in. equals 100 ft. Profiles shall be made on sheets 12 in. by 56 in., to a vertical scale of 1 in. to 20 ft. and horizontally 1 in. to 400 ft.

These specifications require that the right of way maps show the width of right of way, a schedule of the grantor and grantee of the property, with a complete record of its filing, the property lines of adjacent land owners, the section and quarter section lines for a distance of one mile on each side of the center line of the railway, the alinement, tracks and other improvements on the right of way. The same data in greater detail are to be shown on station maps.

On profiles the vertical projection of the original ground surface on the center line of the railway is to be shown with the present grade line, including data regarding the rates of grade and elevation. All bridges and openings in the track are to be shown in vertical projection with data showing the average depth of penetration of the piling in each bent of trestles and the character and depth of the foundation of masonry structures. All quantities of clearing, grubbing, grading and classification of same, overhaul, masonry, timber in wooden bridges, weights of steel bridges, etc., are required as well as the alinement of the main track, location of passing tracks, etc.

The railways were given until September 1 to file objections

to these specifications, with the Interstate Commerce Commission and the committee of engineers prepared objections which were accordingly filed. The matter is now in the hands of the Interstate Commerce Commission for final action and it is expected that a decision will be given in the near future.

The railways objected especially to the requirement of the specifications that new maps should be furnished without making investigation of the records now possessed by the railways, as they did not feel that they should be put to great expense to prepare duplicate maps on a slightly different form where this information has in many cases already been prepared for a similar purpose. This is especially true in the west where a number of roads have prepared such information for various state valuations. The railways have not objected to the preparation of such information in accordance with the standard plans outlined by the commission wherever such information has not previously been collected and new maps are necessary, but do not feel that they should be put to the expense of redrawing all these maps for the sake of uniformity alone. From data collected by one of the railways of California when preparing maps similar to those specified, this additional expense will exceed \$20 per mile of line or over \$5,000,000 for the entire country.

The railways also objected to furnishing information regarding the property lines and names of owners of property beyond their right of way lines, as they have no means of accurately securing this information, and further believe that this is beyond the limits of the valuation act passed by Congress. They also feel that they should not be required to prepare original tracings to file with the commission. As outlined above, many roads already have this information prepared on tracings and can readily furnish the Board of Engineers with blue or white prints and vandykes. Under these conditions they feel that it is an unnecessary expense to be required to make additional tracings. Furthermore, the expense of revising these records to bring them up to date from time to time is correspondingly increased. Throughout the entire discussion the railways have felt that they should not be burdened with the expense of furnishing any information not necessary to the investigation and determination of values, and that they should not bear the cost of preparing and maintaining the records and files of the commission in support of this valuation.

It is now expected that the actual valuation work will be undertaken to a limited degree in the south about the first of the year. It has been tentatively decided that where the railways have already made an inventory of their property the government shall proceed with its valuation work by sending a party over the line to carefully check the data furnished by the railway. The railway will provide an engineer to accompany this party and to provide any further information. Where no valuation has been made by the railway, the method of procedure has not been fully decided on.

The entire country has been divided into five districts, each under the general supervision of one of the five members of the Board of Engineers, who will have as his assistant in direct charge of the work in his territory, a district engineer. While each member of the board will devote the greater portion of his time to the work in his own district, he will act with the other members of the board on any questions of importance.

PIG-PEN COACHES IN INDIA.—A correspondent of the *Allahabad Pioneer* is exceedingly wroth with the North-Western Railway on account of the dirty state in which he found the first-class coaches on the section of the line, Lala Musa-Rundian-Mahmud Kot. "We suppose ourselves," he writes, "to be ahead of the Chinese, at least in the matter of railways. I assure you, sir, the Chinese would hardly put their pigs into conveyances such as I have described, and my excuse for so long a letter is that I object to being treated worse than a Chinese pig."

# STEEL FRAME BOX CARS FOR THE FRISCO.

Designed to Be Water-Proof, Burglar-Proof, Grain-Leakage-Proof and to Protect the Lading from Damage.

Few roads have given as much attention to the damage to freight, and the resulting freight claims, caused by the use of defective cars as has the St. Louis & San Francisco. In the first of a series of articles on "Defective Box Cars and Damaged Freight," *Railway Age Gazette*, April 12, 1912, page 835, statistics were given which showed that for the year ending June 30, 1911, the damage to freight which could be directly traced to defective cars on the Frisco amounted to \$43,160.09, or 8½ per cent. of

or Canadian Pacific type construction, of 80,000-lb. capacity, and have the following general dimensions:

Inside length .....	40 ft.
Length between end sills.....	40 ft. 11 in.
Length over running boards.....	42 ft. 1 in.
Length over striking castings.....	42 ft. ¼ in.
Center to center of bolsters.....	31 ft.
Width inside .....	8 ft. 6 in.
Width over steel side sills.....	8 ft. 8½ in.
Height from top of floor to under side of carline.....	8 ft.
Height from rail to top of floor.....	4 ft. 1 in.

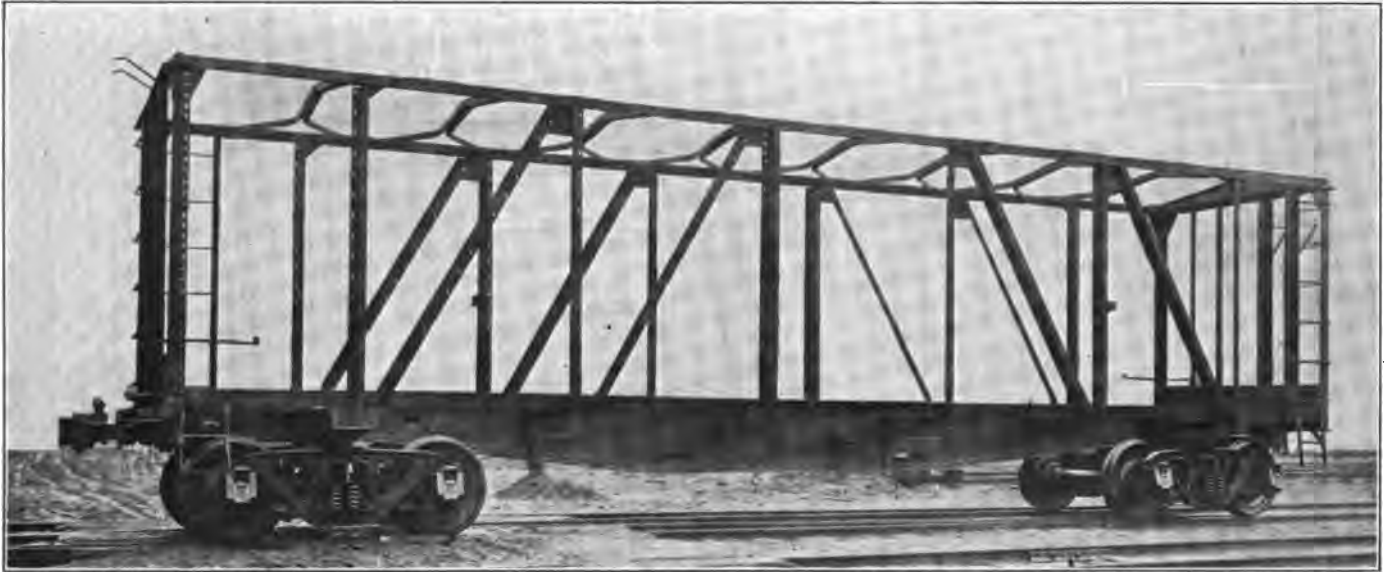

Steel Frame for St. Louis & San Francisco 40-Ton Box Cars.

the amount paid out for damage and loss to freight on that road. In designing the last order of 1,000 box cars that road has given special attention to making the cars burglar, water and grain leakage proof, as well as providing a smooth style of interior construction, with a view to reducing to a minimum the destruction or injury to package freight in paper bags, boxes, or other insecure packages. The cars are of the outside steel frame

Height from rail to eaves.....	12 ft. 5½ in.
Width of side door opening in clear.....	6 ft.
Height of side door opening in clear.....	7 ft. 7½ in.
Truck wheel base .....	5 ft. 6 in.

The steel underframe, together with the steel framing for the superstructure, including the eight Posson-I-beam carlines, furnished by the Camel Company, provides a comparatively rigid structure and furnish a very substantial support for the roof.



Forty-Ton Outside Steel Frame Box Cars; St. Louis & San Francisco.



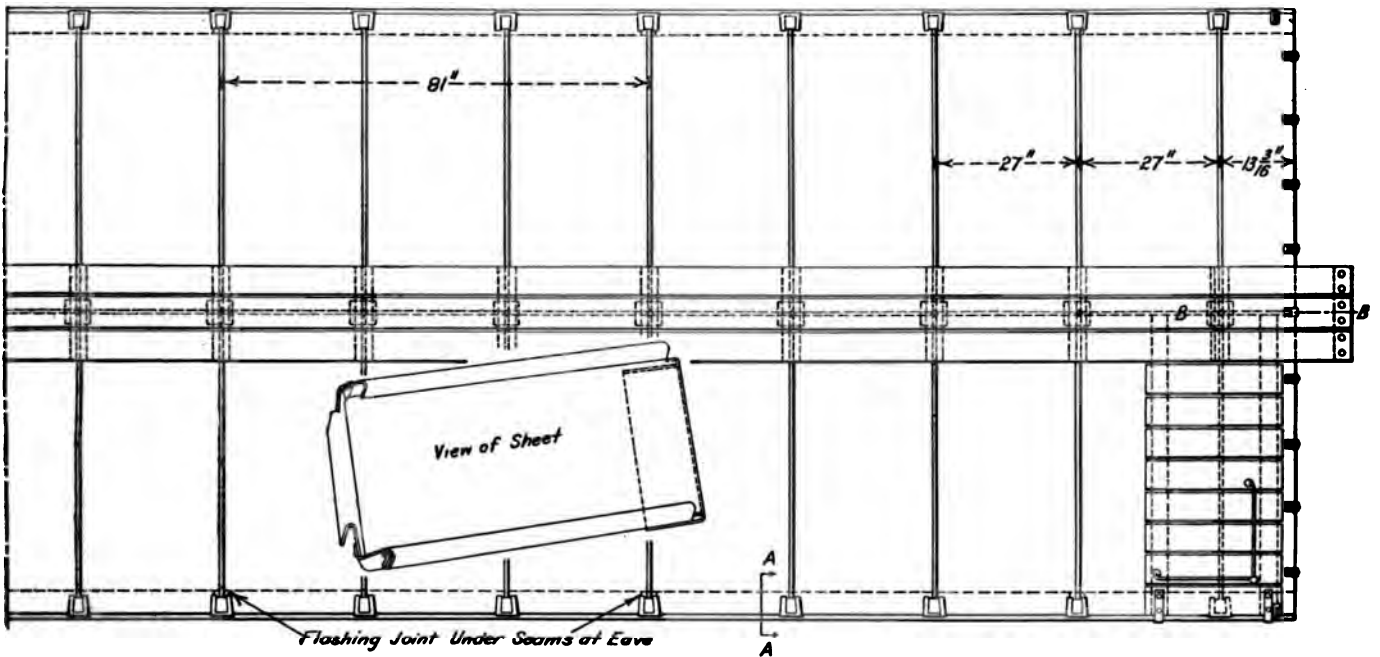
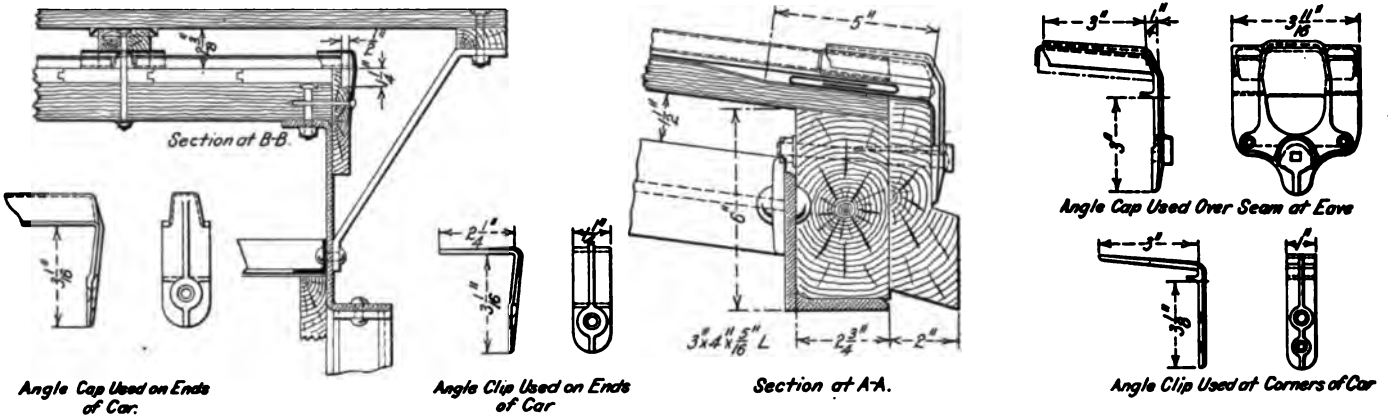
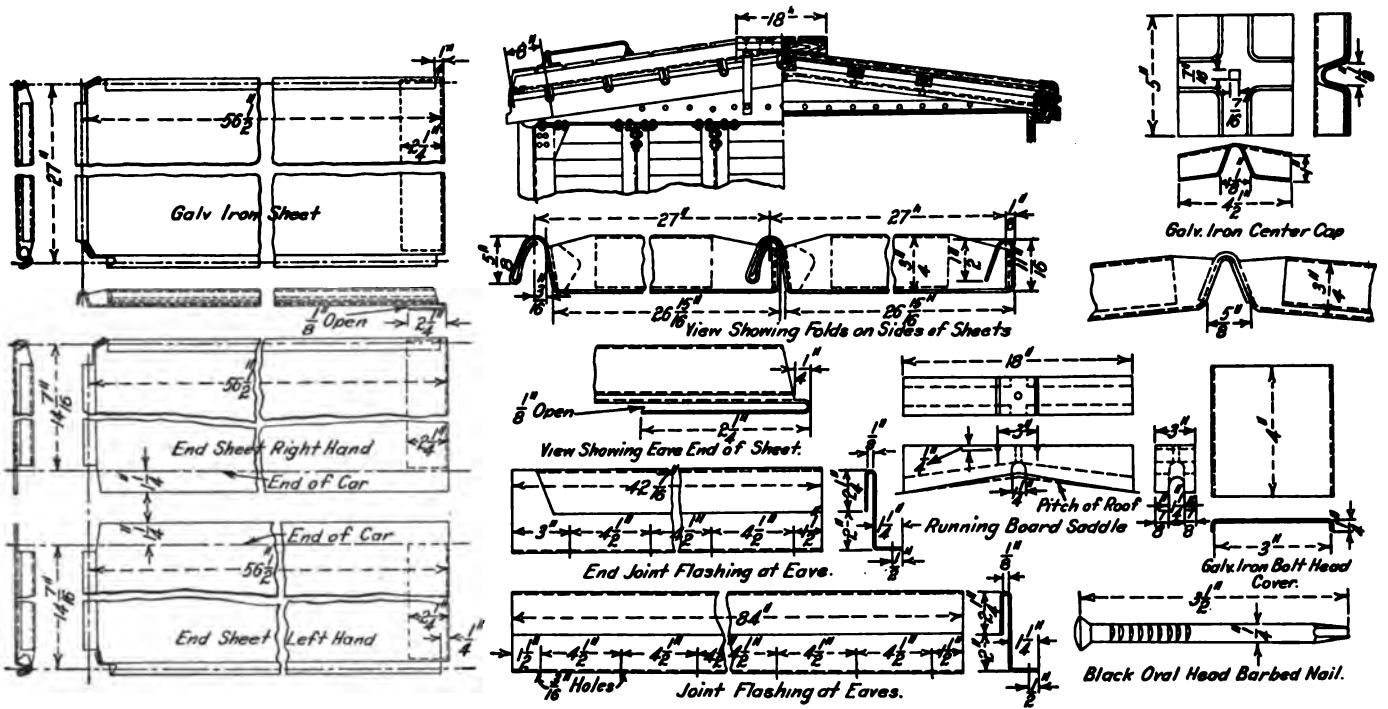

General Arrangement and Details of Murphy X L A Roof as Used on the Frisco Box Cars.

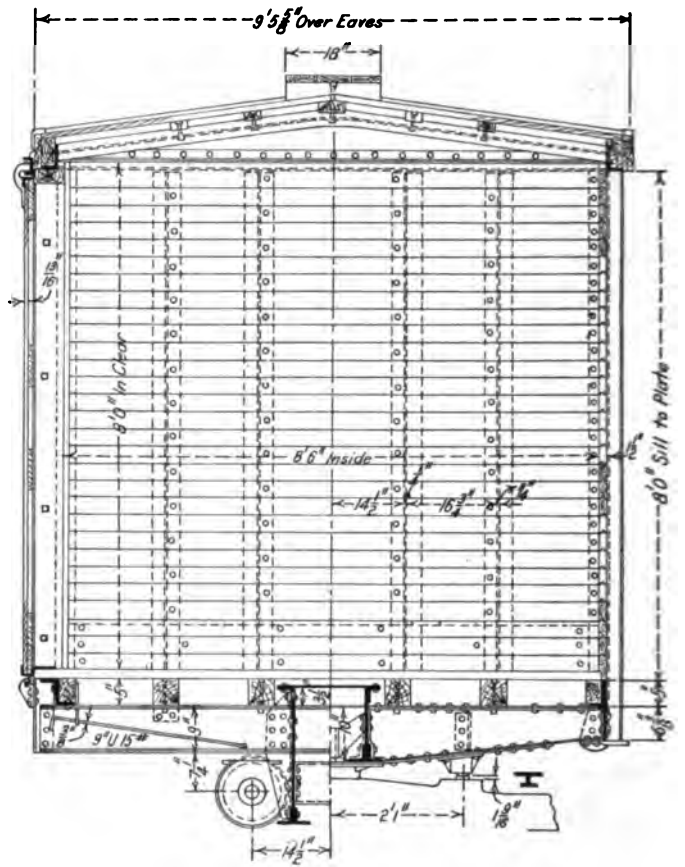
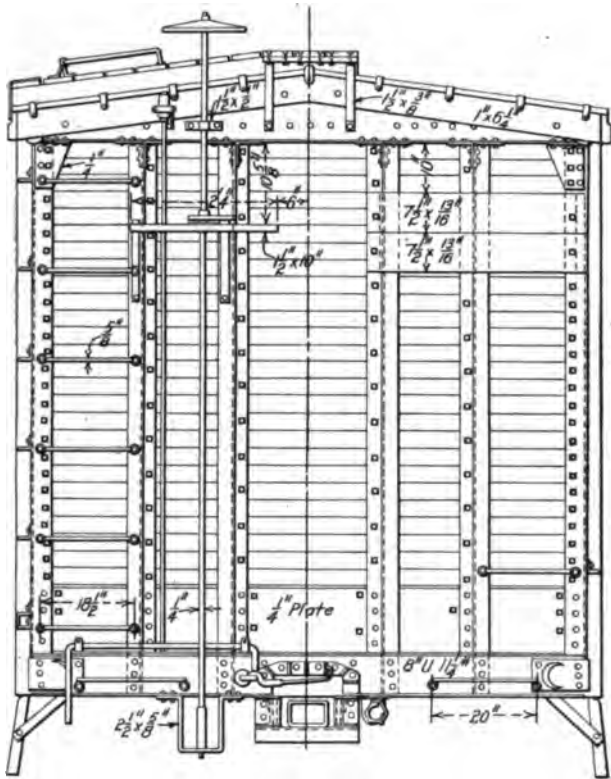

End and Sectional Views of 40-Ton Frisco Box Cars.

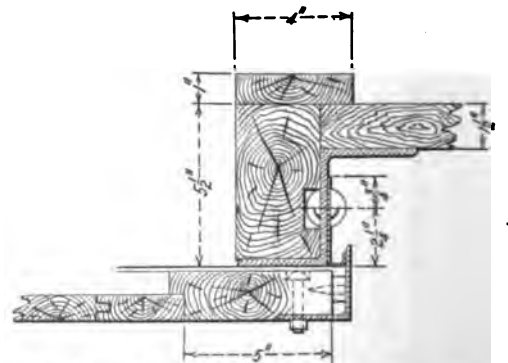
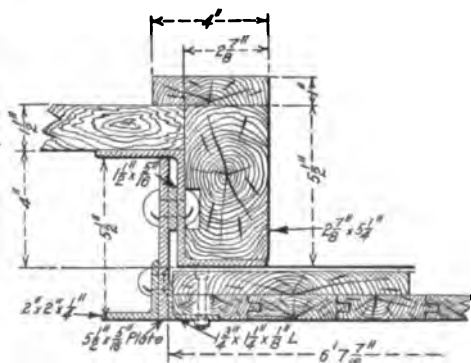
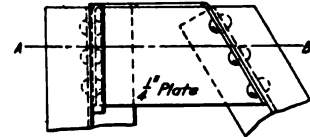
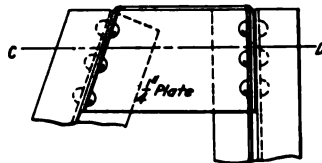
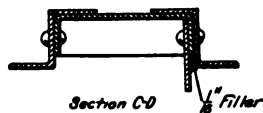
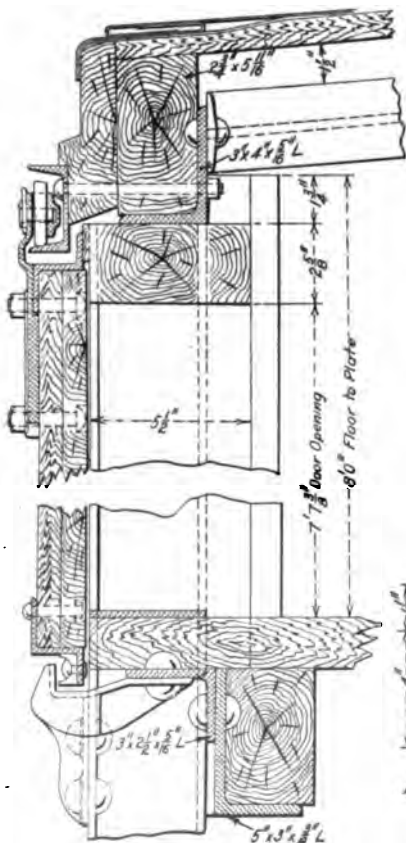

Front Door Post

Rear Door Post

Details of Side Door Application as Used on Frisco Box Car.

A Murphy outside metal roof, type X L A, is used and as an additional safeguard against leakage, the railroad specified that this was to be placed over a layer of asphaltum coated burlap, which was laid flat on the single course of 13/16 in. yellow pine roofing boards.

The center sills consist of 1/4 in. web plates with 3 in. x 3 in. x 1/4 in. top angles and 3 in. x 3 in. x 3/8 in. angles on the outside at the bottom and 3 in. x 3 in. x 5/16 in. angles on the inside. The web plates are continuous between the bolsters and extend 2 ft. 2 1/2 in. beyond them in order to provide for the splicing of the draft sills. The center sills are 26 in. deep at the center for a distance of 11 ft. and taper to 13 7/8 in. in depth, 10 in. back of the center line of the bolster. A 20 in. x 1/4 in. center sill cover plate extends for the full length of the car. The draft sills are of 3/8 in. pressed steel plates flanged to Z

is 14 1/2 in. x 3/8 in. and passes through slots cut in the center sill webs. The bottom cover plate is 18 in. x 3/8 in. The center filler is of malleable iron; a steel casting forming a combined roping and jacking casting is applied at the ends of the bolster. The diagonal braces in the underframe extend from the juncture of the side and end sills to the juncture of bolster and draft sill and consist of 5 in., 6.5 lb. channels placed with the flanges down. There are four 9 in. channel floor beams, weighing 15 lbs. per foot, which extend the full width of the car and pass through slots which are cut in the center sill web. They pass under the side sill and form a direct connection with the Z-bar side posts.

The side plates consist of 4 in. x 3 in. x 5/16 in. angles, extending the full length of the car, and with the 4 in. flanges vertical. The side posts are 3 in., 6.7 lb. steel Z-bars, which

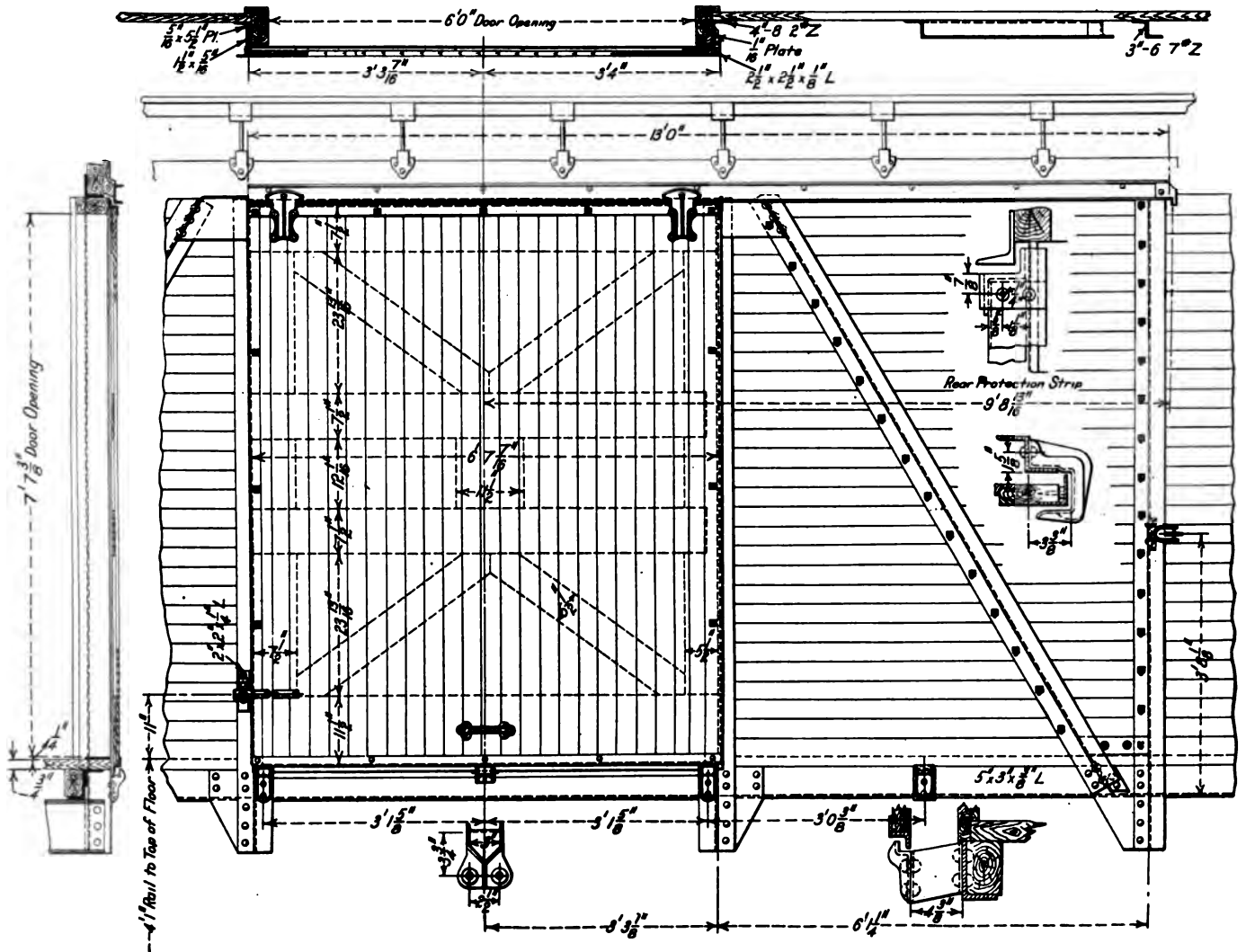

Side Door Construction Used on Frisco Box Cars.

shape, and are connected to the striking castings at the front by 3 in. x 3 in. x 5/16 in. angles. Cardwell type G-11 draft gear is used with Latrobe 5 in. x 7 in. shank steel couplers. The couplers are controlled by the Imperial Appliance Company's uncoupling device.

The side sills are 5 in. x 3 in. x 3/8 in. angles extending the full length of the car and are secured to the end sills by 1/4 in. pressed steel combined corner bands and push pole pockets. These sills rest directly on top of the bolsters and crossbearers with the 5 in. leg vertical. The end sills are 8 in. channels weighing 11.25 lbs. per ft. The end sill top cover plate is 12 in. x 1/4 in., shaped to conform to the contour of the end sills.

The body bolsters consist of 5/16 in. pressed steel channel plates placed 6 1/2 in. apart back to back. The top cover plate

extend from the underside of the side plate angle to the bottom of the bolsters and cross-bearers, to which they are riveted. The center side braces are also 3 in., 6.7 lb. Z-bars, while the intermediate side braces are 3 1/16 in., 8.4 lb. Z-bars. The door posts are 4 in., 8.2 lb. Z-bars, as are also the end posts at the center. The intermediate end posts are 3 in., 6.7 lb. Z-bars. The corner posts are 5 in. x 4 in. x 3/8 in. angles, which extend from the underside of the side and end plates to the underside of the end and side sills. Angles of 1/8 in. pressed steel at each corner of the car perform the function of rain caps, closing the joint between the side and end plates and protecting the top of the corner posts.

The end plates are 3/16 in. material flanged to a Z shape 10 15/16 in. deep at the center and tapering to the side plates



with the ends flanged around and riveted to the side plates. The end plate has a  $3\frac{3}{8}$  in. flange at the top, which turns in and provides a bearing for the ridge pole and purlines. At the bottom it has a 4 in. flange turned outwardly to form a bearing for the end and corner posts. The ridge pole is of yellow pine,  $2\frac{3}{16}$  in. x 5 in., and the purlines are  $1\frac{3}{4}$  in. x 3 in. The side fascia is of yellow pine, 2 in. x  $6\frac{1}{4}$  in., and the end fascias are 1 in. x  $6\frac{1}{4}$  in.

The frame work, being on the outside, makes it necessary to provide an inside lining only, as shown on the drawing, and the sheathing is in narrower widths than usual with a view to reducing the shrinkage of the side planks. Ordinarily in this type of car the material is used in  $5\frac{1}{4}$  in. widths, while on the Frisco cars it is only  $3\frac{3}{4}$  in. wide. The lining, which is  $1\frac{1}{2}$  in. thick, is connected to the members of the metal frame work by  $\frac{3}{8}$  in. carriage bolts. The lower side board is cut in  $\frac{1}{2}$  in. at the floor level to allow the floor planks to pass under the edge. At the ends of the car the floor board is gained  $\frac{1}{2}$  in. to allow the lower end lining board to fit below the floor level, thus insuring a tight fit. The end is also reinforced at the bottom of the lining for the full width of the car by placing a  $\frac{1}{4}$  in. steel plate on the outside of the lining extending about 9 in. above the floor and riveted to the end and corner posts. The lower edge of this plate is flanged at the bottom and is riveted to the end sill cover plate. This not only stiffens the ends but is an additional precaution against the leakage of grain at that point. The flooring is of yellow pine,  $1\frac{3}{4}$  in. in thickness, and is nailed to side nailing stringers of yellow pine, 3 in. x  $4\frac{5}{8}$  in., and two center and two intermediate stringers, 5 in. x 5 in. The flooring at the door openings is supported by 3 in. x  $2\frac{1}{2}$  in. x  $5/16$  in. angles, riveted to the side sill angle.

Wooden ends were used on 973 of the cars and corrugated metal ends furnished by the Standard Railway Equipment Company were placed on 27 of the cars for test purposes.

The side doors are equipped with Jones Peerless fixtures and Positive malleable iron door fastenings. The bottom guides are riveted to the door post, floor support angle and the  $\frac{1}{4}$  in. bracket. The door is stiffened horizontally at the top and the bottom by  $1\frac{3}{4}$  in. x  $1\frac{3}{4}$  in. x  $1\frac{1}{4}$  in. x  $3/16$  in. Z-bars; it is stiffened vertically at the front edge by a  $1\frac{3}{4}$  in. x  $1\frac{1}{4}$  in. x  $\frac{1}{8}$  in. angle, and at the rear edge by a  $2\frac{1}{2}$  in. x  $2\frac{1}{2}$  in. x  $\frac{1}{8}$  in. angle. The front edge of the door is protected against weather, cinders, etc., by a  $5/16$  in. vertical bar which is riveted to the door post and spaced  $5/16$  in. from it by a filler, the bar abutting the front edge of the door when the door is in a closed position. The rear edge of the door is protected by a  $1/16$  in. steel bar which is riveted to the door post and is bent in a U shape to form a contact with the vertical rear door edge stiffener angle.

The trucks have cast steel frames furnished by Scullin-Gallagher Iron & Steel Company, and the cast steel truck bolsters were made by the same company. These cars were built by the American Car & Foundry Company.

**KWANGTUNG YUEH HAN RAILWAY.**—The Canton-Hankow Railway, begun by the American China Development Company, and since 1905 under construction by a Chinese company, has been pushed forward rapidly this summer. On May 25 the important station Ying Tak was formally opened to traffic. On June 1 the road was declared open to the next station, Ho Tou, nearly 96 miles from Canton, and to Sha Ho, at mile 109 early in August. Beyond this point to Shin Kwan the roadbed has been nearly completed and is about ready in all parts for laying the rails. If advanced at the same rate during the fall and winter it is expected that the line will be open to Shin Kwan, 139 miles from Canton, by the end of 1913 or shortly thereafter. North of Shin Kwan nothing has been done beyond the preliminary survey. From here on to the end of the province will be far the most difficult part of the road to construct. In the North River Valley there will be a number of fills, cuts, bridges and culverts, and tunnels.

## SAFETY FIRST EXHIBITION OF THE PENNSYLVANIA RAILROAD.

A comprehensive exhibition of safety-first devices was opened in the Y. M. C. A. quarters in the Pennsylvania Station, New York, on September 26. The exhibition occupied three rooms, and was held under the auspices of the safety committee of the Manhattan division of the Pennsylvania Railroad. It was held primarily for the purpose of educating the employees of that division and, in order that both day and night workers might attend, the doors were opened early in the afternoon and were not closed until half-past ten at night. The exhibition closed on September 30.

Among the exhibits were the following: Section of track; miniature telegraph line; emery wheels, guarded and unguarded; insulated or protected track tools; a lathe showing gear guard; chip guard; drill press with guard; saw guard; shaper guard; fire extinguishers; old style set screw and hollow set screw which has taken its place; boards showing protruding nails; defective jumpers and good jumpers; unprotected and protected station platforms; ropes and chains, perfect and defective; marker lamps in good and bad condition; barrels and boxes of freight properly and improperly piled on floor and on hand trucks; fire alarm apparatus for station and tunnels; safe and unsafe heavy lamp shade supports; switch and rheostat with five parts protected; safe and unsafe devices for operating baggage elevators; brake hose, perfect and imperfect; hundreds of photographs illustrating safe and unsafe methods of working on cars, tracks, etc.

The various safety appliances attached to the different kinds of equipment exhibited, were not only thoroughly inspected by those who attended, but there were demonstrators present to show and to explain the right and wrong methods of handling machinery, tools, etc.

Practical demonstrations by employees of first aid to the injured were features at the evening sessions. For example there was an exhibition in resuscitation from electric shock. The increasing use of electricity about the shops, stations and all other property of the Pennsylvania Railroad, makes it necessary that employees be qualified to render intelligent assistance in case of electrical accident. To this end employees are instructed first, in the safe removal of the victim from contact with live wires and third rails; second, in the approved method of resuscitating persons apparently dead from electric shock, and third, in the care of the victim when natural respiration has been restored.

Employees also illustrated the treatment for hemorrhage, fracture, burns, unconsciousness, fits, heat exhaustion and sun-stroke. The Pennsylvania standard "first aid packet," which may be found at stations, telegraph towers, in yard buildings, tool houses and on trains, played an important part in these demonstrations. The "first aid packet" is a sanitary tin box containing two aseptic compresses wrapped in oil paper, one cambric bandage, one triangular bandage and two safety pins.

Several booklets issued by the Pennsylvania Railroad for the benefit of the employees were distributed. Some of them were: Safety Hints and Suggestions for the Prevention of Personal Injury Accidents; Precautionary Measures for the Prevention of Accidents at Freight Stations; Instructions for the Guidance and Protection of Employees (in English, Italian and Polish); Hints on First Aid to the Injured, and Courtesy.

**LIGHT RAILWAYS IN INDIA.**—The Bombay government, in the course of a review of the Land Revenue Administration, states that one of the two most important events of the year was the steady progress made in the extension of feeder railways, and that the network of light railways which are under construction in Gujarat will have far-reaching results in promoting the welfare of the districts through which they pass.

## HOWARD ELLIOTT AND NEW ENGLAND.\*

When I decided to come back to my old home in New England some of my friends said, Why leave this great and growing West for a country that is developed and finished? I told them that in my judgment there was going to be just as much growth and development in New England in the next twenty-five years as anywhere else, and there will be if the intellectual and financial ability of the men in New England can co-operate unselfishly with that end in view. I told them that I had a great love for New England, and that, strong as was my feeling for the West, the idea of spending the last years of my life here, where my relatives and lifelong friends are, and where my children are going to school and college, appealed very strongly to me.

There is an old saying that reads: "*Man's work lasts till set of sun; woman's work is never done.*" This is true about the railroad. Its work is never done. Men may think they have provided sufficient transportation facilities for years to come, but the growth of the country is so great that things that looked far too big a few years ago are far too small now. For every dollar of gross earnings produced by the railroad there is a value in the plant used of nearly \$6 upon which owners are entitled to a fair return. For every increase of \$1 in gross earnings which reflects the increase in general business in the country there must be provided by someone more than \$6 of new capital for increased and improved facilities.

For New England to grow as she will in common with the rest of the country she must have a comprehensive, adequate and safe system of transportation. The new capital needed in this section for each increase of \$1 of gross earnings will be greater than the average in the United States because of more perfect and luxurious service demanded.

Each year the New England lines and associated properties, including the steamboats and electric lines, carry 252,000,000 passengers, a number which is more than double the entire population of North American. Expressed in other terms, the New England lines hourly transport 30,000 people.

The figures for the volume of freight business indicate an immensity of transactions which few appreciate. Every year 78,000,000 tons of freight are carried—9,000 tons every hour. The complexity of the problem, however, is not indicated by the tonnage alone. In connection with its movement 13,600,000 way-bills are issued. Each way-bill, however, usually covers several items, and it is estimated that the number of freight transactions in a year is 44,000,000, 141,000 for each working day, or nearly 5,875 for every hour of the day. Is it to be wondered at that some shipments go astray or that some freight is damaged?

The unusual character of the railroad business of New England is apparent when the returns for the New Haven road are compared with those for the entire United States. Considering all the railroads of the country as one system, two tons of freight are transported to every passenger. On the New Haven road alone, the ratio of freight to passenger business is reversed. That road transports only one-third of a ton to one passenger. The passenger density of the New Haven road is more than six times as great as that on all the railroads of the country considered as a system. These figures show the marked preponderance of passenger business in New England. Through the Boston South Station alone 105,000 people pass daily. The passengers passing through that one station each week equal the total population of Boston.

To have this great transportation machine work smoothly with the fewest points of obstruction and interruption—the least amount of friction, and with the greatest harmony among all its constituent parts, means, in the long run, the furnishing of the best transportation service to the people of New England.

The total taxes paid by these properties was \$7,640,000, a substantial contribution to the funds for carrying on the government.

But the people of New England have other interests in their railroads. Not only is the railroad service a vital part of the social organization, but its earning power as well affects a large and widely distributed number of investors. The number of security holders of the New Haven and New England lines and associated properties is estimated at 60,000. The majority of them live in New England.

It is commonly believed that railroad stocks are concentrated in the hands of a few. That this is not true of the New Haven and Boston & Maine will be apparent when it is known that 43 per cent. of the New Haven stockholders own only from one to ten shares each, and 38 per cent. own from 11 to 50 shares each. With Boston & Maine stock the proportion of investors holding a small number of shares is even more striking.

To maintain and operate this great transportation machine requires the services of from 90,000 to 100,000 men (92,792 on last pay-roll). These employees and these investors are drawn from all walks of life. They are human beings with hopes and aspirations and joys and sorrows. The livelihood of employees necessarily depends upon the return from their labor and this in turn depends upon the prosperity of New England and the railroads of New England. In a smaller degree the comfort and well being of many investors depend upon the return from their investment, and this also depends upon the prosperity of New England and of her railroads. These investors and these employees, with their families, on the basis of four to one, make 640,000 people, or nearly one-tenth of the population of New England. Should not their rights, comforts and feelings be considered carefully in the current tempestuous discussion in regard to the New England railroads?

The stockholders of the three important New England railroads—the New Haven, the Boston & Maine and the Maine Central, have selected forty-eight men to act as their directors. Of these, three sit on all three boards and eight sit on two boards. Of the forty-eight directors, forty-two live in New England, four in New York and two in Philadelphia. Those who are also directors of the so-called Trunk lines outside of New England are five in number.

These directors are interested in the welfare of the roads they represent, and of the country that those roads are trying to serve. They exercise the final powers of management, and can approve or disapprove the action of the officers, and can direct them. They cannot know all details and they must rely largely on the reports and recommendations of the officers on whom rests the first responsibility of careful investigation of the problems of management. They demand that the officers give their undivided time and attention to the railroad business, and to working harmoniously with the patrons of the roads, the employees and the public authorities.

The report of the Interstate Commerce Commission about the New England railroad situation was submitted by Mr. Prouty on June 20, 1913. Since then the directors have been engaged very busily in discussing the large question of a new management and of some financing that is imperative. The important suggestions in that report will be taken up and considered very carefully and some conclusion reached as rapidly as practicable. The very grave importance of the suggestions and recommendations and the source from which they come mean that they cannot be decided hurriedly and without very thorough study. Already some steps have been taken so as to have closer supervision of the details of the operations of the properties. Three men have been selected to fill the important position of president on the Boston & Maine and Maine Central, on the New Haven, and on the New York, Ontario & Western. One large operating division on the New Haven road, formerly under one superintendent, now has a general superintendent and two division superintendents. Other steps of this character will be taken if careful study of the situation shows that they are necessary for efficiency and safety.

It is difficult to obtain the material things needed for the up-building of a railroad, but it is even more difficult to get men.

\*Abstract of address before the Boston Chamber of Commerce.

No more important work faces the management than to create a staff of officers that can carry on this great work and have it so organized that when for any reason one man retires there is another to take his place. Equally important is the work of encouraging the great army of employees and of inspiring them with a feeling of loyalty to New England and to the railroad, and of making safe the conditions under which they work. Every effort will be made to build up a complete staff of officers and men from those now in the service and in New England, men who know the local conditions, and who will respond loyally to suggestions for the closest, most efficient and economical operation. These two pieces of work are even more important to the travelling and shipping public than to the owners, because the daily work of the railroad must be done, or people will starve, or freeze, and business stop. This daily work cannot be done right if officers and men are harassed and worried.

Let me ask you in all seriousness, if service with the New England railroads has been attractive enough in the last few years to draw into it men who have any choice in selecting their life work. Will not better results be obtained if more consideration is given to officers and men in the service—men who are as good as those in other walks of life, and the large majority of whom are most anxious to do their duty? Is it not in the interest of New England to treat her servants in the railroad service so that the best talent in the country will want to serve? Mr. McDonald, his staff and employees are trying to accomplish results on the Boston & Maine and Maine Central; Mr. Hustis, his staff and employees will try to do the same on the New Haven road; Mr. Campbell is helping both in trying to adjust a complicated rate or price list so as to earn enough to give the prompt and regular service that all want. Mr. Kerr and his men are doing the same for the Ontario & Western. Other officers and men are doing their best with other properties. I shall work with and through these men and try to have their knowledge and experience, as well as my own, used to the very best advantage for honest, economical management, and for efficient and safe operation.

All of us are animated with a high purpose to do our full duty, and we have no desire for self aggrandizement and self glorification. Our reward will come, if, in time, this complicated machine can be adjusted so that it will run smoothly, without friction, pay a fair return to the owners and become so much a part of the daily life of the public that no more attention is paid to it than is paid now to drawing water from a faucet or turning on an electric light.

Will we not advance the interests of New England, and the peace, prosperity and contentment of her people if we are careful to be temperate and accurate in our statements and criticisms of others?

Man-fashion, we must take the situation as it is and carry the burden as well as we can. We must be thankful for the good things of the past, and try so to improve the situation that those who come after us will be thankful for some good work and not too uncharitable about the mistakes that will undoubtedly be made. We will try, however, not to make the same mistakes twice. It does not seem as if any positive beneficial results can be obtained by a lack of confidence and by continuous wrangling. If the people of New England cannot trust their railroad management, and if the railroad management cannot trust the people of New England, a situation is created that is unfortunate now and more unfortunate for the future and for our children and grandchildren, because so much needs to be done in the developing and upbuilding of the New England states. I believe we can all trust one another, and I, for my part, will do all that I can, and see that the officers and employees of the various railroads do all they can to bring about that condition. Intelligent and wholesome criticism is asked for and expected, and such criticism is a spur to the management to be faithful to their trust and careful in their work.

There will always be differences of opinion between those that

you represent, buyers and users of transportation, and those that I represent, manufacturers and sellers of transportation, because buyers and sellers in the nature of things will not always agree about the price and the quality of the article or service furnished. In such cases I hope we can discuss the differences calmly, without prejudice, and without any disturbance to the transportation machine which is so delicately adjusted, and without any demoralization among officers and employees, because any disturbance of this transportation machine reacts in many directions. I hope that if we should be unable to agree among ourselves, we can arbitrate the matter in an orderly way before those tribunals and courts which have been created for such purposes.

In managing a railroad, just as in any other business, different kinds of talent and ability must be employed to safeguard the business—engineering talent, operating talent, commercial talent, and financial talent. In a very large business the best talent should be employed and the going prices for such talent must be paid. The management of the New England lines wants to use the best financial talent it can find to help it in raising the money needed. It wishes to employ those bankers, no matter where they live, who can do the work. It would prefer to employ bankers in New York and Boston who naturally want to help the development of the country and of the roads. The management of the properties will be more than pleased if New England bankers, banks and investors will furnish their full share of the money needed now and in the future, and will assist in obtaining that money in the markets of the world.

If a business is stagnant and dying of dry rot no new money will be needed and there will be no need of the help of the experienced banker or financial agent; but if the business is to grow, especially if it is a public service business, which must respond to the demands of the public for good service, new money over and above what can be obtained from earnings is needed at frequent intervals and in very large amounts.

The greater the amounts needed the greater the need of expert advice and financial aid of the very best quality, because by training and experience bankers know where and how money can be obtained. With proper aid from bankers the officers of the company will not have their attention too much diverted from the work of careful management, safe and efficient operation, and good service to the public.

The United States government, state governments and municipalities all turn at times to the banker for his aid in placing their securities in the hands of small investors all over the country.

New England can and will have the kind of railroad management and service to which she is entitled. Payment for this can be made in three ways:

- (1) By some increase in rates.
- (2) By the stockholders, who live in the country to be served, advancing the money.
- (3) By borrowing the money needed, wherever it can be obtained. Probably a combination of all three plans is necessary at this time of crisis in the New England railroad situation. All are interested in helping to uphold the credit of New England roads so that money can always be obtained on the best terms.

If and when the money needed is furnished the management proposes to spend it prudently in improving and perfecting properties now owned. The management proposes to confine its activities to the transportation business.

---

PARAGUAY CENTRAL RAILWAY.—The Paraguay Central Railway Company has received the following cablegram from its general manager at Asuncion with reference to the train opening for business of the ferry between Paraguay and the Argentine: "Expect to open freight traffic to Buenos Aires in a few days. First passenger train leaves Buenos Aires for here on October 12."

### CONSTRUCTION OF THE BUCKHANNON & NORTHERN RAILROAD.

By R. E. KERR,

Assistant Engineer, Buckhannon & Northern, Morgantown, W. Va.

Of the bituminous coal measures of West Virginia and Pennsylvania, one of the most valuable is that known in northern West Virginia as the Pittsburgh vein, a low sulphur coal which is easily coked. There is at present a vast area of this coal measure which is not accessible to the markets on account of lack of transportation facilities and it was to bring a portion of this coal to market that the Buckhannon & Northern, now nearing completion, is being built.

This railroad starts at the West Virginia-Pennsylvania state line, where it connects with an extension of the Monongahela railroad which is also now being constructed, and follows the west bank of the Monongahela river to Rivesville, W. Va., about five miles north of Fairmont where it connects with the Catawba

grades are very light, the maximum on the Buckhannon & Northern being 0.15 per cent. There are extensive fields of coking coal throughout the entire distance and as these roads were all built primarily as coal and coke carrying roads the grades were kept as light as possible.

The original survey for the Buckhannon & Northern was made in 1902 as a branch of the line then being constructed. In the fall of 1903, construction was stopped on the main line and nothing further has been done on it since that time. A new survey of the branch was made in the early part of 1910, and the company immediately started to procure right of way which was all acquired before construction was commenced.

Plans were made for a first class line as far as physical conditions are concerned. As before mentioned, the maximum grade is 0.15 per cent., and there are several miles of level grade. The maximum curvature is 8 deg., and there are only two curves this heavy, both of which may be later taken out and replaced with 6 deg. curves, making that the maximum. The structures

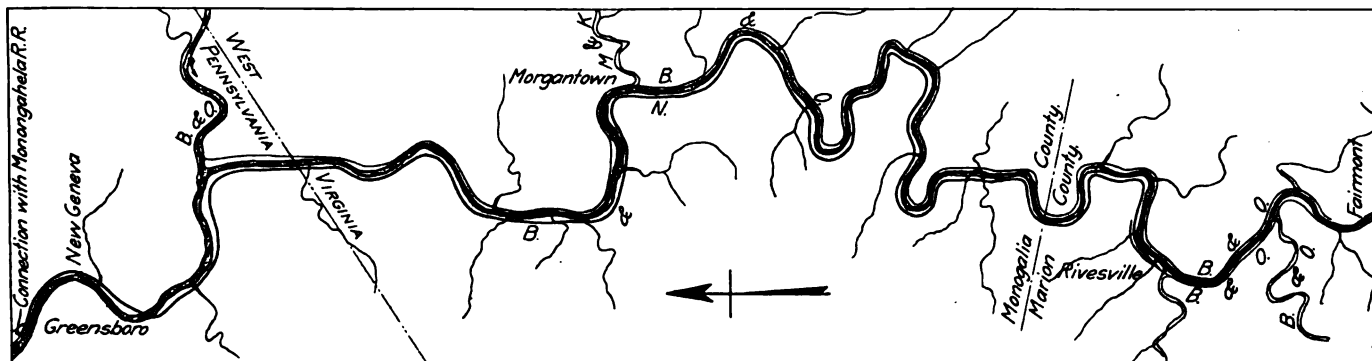

Location of Extension of Monongahela Railroad and Buchannon & Northern Into West Virginia Coal Fields.

branch of the Paw Paw railroad, a subsidiary of the Baltimore & Ohio. The coal to be developed all lies west of this line and can be conveniently reached by branches built up the tributaries of the Monongahela. There are several workable veins in this territory other than the Pittsburgh, the most important being the measures known locally as the Sewickley and the Freeport.

The stock in the Buckhannon and Northern is owned by the Little Kanawha Syndicate, which owns the charters of a number of roads started in West Virginia, Ohio and Pennsylvania, in 1902 and 1903. The stock in this syndicate is now held jointly by the Pittsburgh & Lake Erie, the Pennsylvania and the Baltimore & Ohio. It will have connection with Pittsburgh by way of the Monongahela railroad to Brownsville, Pa., and from there by branches of both the Pittsburgh and Lake Erie and the Pennsylvania, and it will reach the eastern markets by way of the Baltimore & Ohio.

The route to Pittsburgh follows the Monongahela river the entire distance, and as the fall of the river is very slight, the

are all designed for the heaviest class of traffic and great care was used to obtain good drainage. The bridges are built on the specifications of the Pennsylvania Lines West. The track is laid on 85-lb. rail with ties spaced 22 in. between centers. Granulated slag ballast was used to put the road in condition for operation, though it is intended to eventually cover this with broken stone.

Construction was started on the Buckhannon & Northern in the early part of 1911 and was pushed as rapidly as conditions permitted. While the grading was not particularly heavy, averaging about 45,000 cu. yds. per mile, it was made difficult by the great number of slides, especially those under embankments, necessitating several changes of alinement after the grading on the original location was practically completed. Most of the excavation was done by steam shovels, but the lighter sections were generally graded with small dump cars filled by hand.

There are five steel bridges on the line, the two largest being Dent's Run bridge, a viaduct 274 ft. long, and the Indian Creek

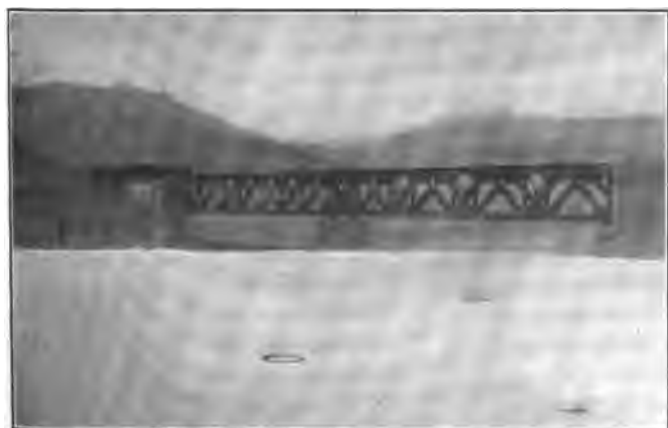

Indian Creek Bridge.



Dent's Run Bridge.



# REPORT ON NORTH HAVEN COLLISION.

Directors, Called "Magicians In the Art of Finance," Blamed  
for Not Having Discovered Defects In Operating Conditions.

The Interstate Commerce Commission has issued its report on the rear collision of passenger trains on the New York, New Haven & Hartford at North Haven, Conn., September 2, when 21 passengers were killed and 33 passengers and 2 employees were injured. It is by Commissioner McChord.

From the statement of facts we take certain details which were not given in the report printed in the *Railway Age Gazette* September 12.

The three sleeping cars which were wrecked weighed 66, 56, and 63 tons, respectively. The rear car was built in 1908, the next one in 1893, and the third, which was less seriously wrecked, in 1906. The flagging rule of the New Haven, in addition to the brief paragraph in the standard code, has additional paragraphs prescribing distances which the flagman must go back. Conductor Adams, of the leading train, was making his first trip between Springfield and New Haven as a passenger conductor; but he was well acquainted with the road. In the past 10 years Conductor Adams had received a number of demerits, on one occasion for drinking while on duty, and he had been reprimanded for failing properly to protect his train.

The report makes no comment on the conflict of testimony as to flagging when Adams' train was stopped at signal 83, north of Hartford. Neither do we find any reference to the testimony of a passenger, Mr. Zollinger, to the effect that the fog was not so dense as appeared from the testimony of the trainmen.

In the four years, 1906-1909, Engineman Miller had been charged with demerits eight times, and was cautioned once, reprimanded twice and suspended once. The statements at the trial to the effect that he had never been disciplined more than once or twice apparently referred only to cases of running past stop signals.

C. H. Morrison, signal engineer, said that 25 of the 154 automatic signals between Springfield and New Haven, had distant signals. He had no record of the exact date when the signals were installed.

The report gives in detail the statements presented by General Manager Bardo and Mechanical Superintendent Wildin, concerning expenditures which had been made or ordered for steel cars and other improvements.

The record of discipline since January 1, 1911, for overrunning signals and for inefficient flagging, which was presented by Mr. Bardo, is given in the report at some length.

General Manager Dean, of the Pullman Company, testified that the average number of cars operated by that company during the year ending July 31, 1913, was 5,953, of which 1,882 were all steel and 404 had steel underframes. The contract between the Pullman and the New Haven companies went into effect January 1 last, and on the first of September 47 per cent. of the Pullman cars on the New Haven road were of steel or steel underframe. Mr. Dean gave the capacity of the Pullman shops as two Pullman cars and four other cars per day; and of the other plants in the country he estimated the capacity as follows:

American Car & Foundry Co.:		
Jefferson plant .....	300	
St. Charles .....	480	
Berwick .....	600	
Wilmington .....	300	
		1,680
Standard Steel Car Co., all plants.....		420
Pressed Steel Car Co.....		360
Barney & Smith .....		420
Harlan & Hollingsworth Corporation.....		250
Wason Car Co. ....		180
Laconia .....		120
The Pullman Co.:		
Passenger equipment .....	1,200	
Pullman cars .....	600	
		1,800
Total .....		5,230

The report then goes on to give the number of passenger cars in service in the country (as reported in the *Railway Age*

*Gazette* August 15, page 269). Following are the principal paragraphs of that part of the report giving the commission's conclusions:

The automatic signals installed on this line were far from adequate to provide for the safe operation of high-speed trains, especially during foggy or stormy weather, notwithstanding the rule governing their operation. In this district, with but few exceptions, there were no distant signals, and an engineman knew nothing of the condition of the block he was approaching until he saw the signal at the entrance of that block, and even in clear weather trains frequently drifted by, enginemen being unable to see the danger indications in time to stop before passing the signals. If distant signals had been installed . . . the signal system would be much safer.

While the officers did not require enginemen to make schedule time in foggy weather and no action was taken in case an engineman lost time on account of the fog, there was no specific rule requiring reduced speed and no special instructions had been issued to the dispatcher or to enginemen regarding the operation of trains during foggy weather. Furthermore, if the records in this case furnish any criterion, it is not unusual to run trains at high speed through fog, and the officers of the road are aware of that fact. While the records show that all five of the express trains lost some time, one of them maintained schedule time from Hartford to Wallingford, a distance of 24 miles.

The dispatcher was aware that the weather was foggy; nevertheless, these five passenger trains were permitted to close up within a distance of approximately 10 miles, with only seven signals properly to space them.

In June, 1912, the enginemen had called attention to the inadequate signals in use on various portions of the road, mentioning, among other localities, the line between Springfield and New Haven, stating that it was impossible to comply with the rules and to make the time required of them. A protest was also made against the use of any signals requiring trains to stop without distant signals or caution indications being provided. This communication and protest were given but scant consideration by the officers of the road. The small number of accidents which had occurred was advanced by the general superintendent as adequate justification for no action being taken in the matter.

. . . As a result of the action of the Connecticut State Commission, a modern signal system is now being installed between Springfield and New Haven. However, to provide for the safe operation of trains until the new signal system is available, either distant signals should be provided in connection with all the signals now in use, or the signals should be properly overlapped, or block operators should be located at stations along this line and required to space trains a full block apart. Between Springfield and Air Line Junction, a distance of approximately 60 miles, there are 15 stations at which train orders can be received and delivered, an average of 1 station for every 4 miles. In view of this fact, a manual block signal system could readily and quickly be placed in service.

During foggy or stormy weather, when signal indications can be seen but a short distance, positive and definite instructions should be given prohibiting the running of trains at high speed.

In view of the congested passenger-train service and the inadequate signal system on this line, as well as the fact that under the practices followed the danger of rear-end collisions is greater when a flagman is returning to his train, the rules should be changed so as to provide that when a flagman has gone back to protect his train he should not be recalled, but should remain out and be picked up by a following train; and if the number of men now provided is not sufficient properly to protect a train under this method, the number of men assigned to a train crew should be increased.

The position of flagman of a passenger train is one of great importance and grave responsibility. The mere aim to select employees who will make competent flagmen is not sufficient; the responsibility for having in this position at all times a man who is known to be competent and reliable rests with the railroad company, and only those employees who have been thoroughly examined and tested and who have demonstrated their fitness in every respect for performing the duties required of a passenger-train flagman should be selected for this service.

General Manager Bardo submitted a list of enginemen disciplined . . . ; the operating officers should have been cognizant of the fact that infractions of this character were occurring with alarming regularity and frequency; and the statements and the records furnished in this case afford conclusive proof that they knew of these dangerous practices. Their responsibility in the matter cannot be evaded.

In the bulletin issued by Mr. Bardo under date of June 1, 1913, the question of the safe operation of trains was discussed and certain rules bearing upon the subject were quoted. But the questions of economy and efficiency were also discussed. . . . The questions of economy, efficiency, and maintaining schedule time were brought out so prominently that it is probable employees might receive the impression from them that the company held these matters to be of equal importance with the question of safety.

It is not sufficient for a railroad company merely to provide signals and rules to govern the operation of trains, to issue bulletins calling attention to the necessity for observing such signals and rules, and to interview and caution employees regarding the observance of signals and rules. But it is the absolute duty of a railroad company to know beyond question whether or not signals are obeyed and rules are rigidly lived up to. Only when this is done can a railroad company provide that measure of protection to which the traveling public is entitled. Mr. Droege's statement that in case employees failed to report instances where enginemen disregarded signals, or flagmen failed to protect their trains properly, there was no method of securing information regarding such occurrences, indicates the entire lack of any adequate system of supervision of employees and of train operation, and the railroad company should without delay reorganize or rearrange its methods of supervision so as to keep in closer touch with its employees and better informed regarding the practices and occurrences on its road.

Mr. Bardo and Mr. Wildin both stated it was their understanding that if the brakes on 85 per cent. of the cars in a train were in working condition the train could be operated without violation of the safety appliance acts. Attention is called to the provision of section 2 of the act of March 2, 1903, requiring that all power-braked cars in a train which are associated together with the prescribed minimum percentage shall have their brakes used and operated. This provision of law clearly prohibits the practice of running a car with its brake cut out in a train otherwise fully equipped with power brakes. To comply with this provision of law railroads almost universally require all the cars in passenger trains to be equipped with brakes in operating condition. It is believed that not only should more complete and thorough inspections and tests be made, but facilities should be provided for making necessary repairs or taking cars with defective brakes out of service in order that all the cars in passenger trains leaving Springfield may be equipped with efficient brakes in operative condition. Under no circumstances should a passenger train be permitted to leave a terminal with less than 100 per cent. of the cars in such train equipped with power brakes in operative condition.

The direct cause of this accident was the failure of Flagman Murray properly to protect his train, the failure of Engineman Miller properly to control the speed of his train in order that he could bring it to a stop before passing automatic signal No. 23, and the failure of Conductor Adams to make certain that his train was properly protected. An additional cause was the failure of Engineman Wands to bring his train to stop, as required by

the rules, before passing automatic signal No. 23, which was in the stop position.

While Flagman Murray had had only limited experience as a flagman, he was familiar with the duties required of him. Had he immediately run back as far as possible and lighted a fusee, the accident probably would not have occurred. The rule requires the flagman to ride in the rear car of his train. Flagman Murray was in the second car from the rear, and, as the train was stopped by an emergency application of the brakes, it is obvious that his statement that he left the rear end of the train immediately after it came to a stop, can not be correct. Instead of running back with stop signals to protect his train, he negligently loitered during the six or seven minutes his train must have stood at this place and at no time was he more than 200 or 300 feet from the rear end of the train.

Enginemen Miller and Wands were experienced men and were well acquainted with the rules and requirements for the safe operation of their trains. On account of the dense fog prevailing they should have run their trains at greatly reduced speed. . . . Although the emergency required an engineman to double out of Springfield on this run there was no sufficient reason why one engineman should be required or permitted to continue double duty for a period of one week, as Engineman Miller had done. In each 24-hour period Engineman Miller had had less than six hours of rest in bed at his home. No engineman who takes his rest in such a manner as Engineman Miller did while performing this double duty can be in proper physical or mental condition to perform the exacting service required of an engineman on a high-speed passenger train. Officers directly in charge should have kept sufficiently close watch over an engineman performing such service to know absolutely whether or not he was securing proper rest.

Conductor Adams was a man of long experience. It was his first duty when his train came to a stop to know that it was properly protected. This duty was flagrantly neglected. His evident lack of confidence in Flagman Murray should have prompted him to make certain that Murray was protecting the train. Conductor Adams was well aware that first No. 95 was closely following his train; it was a serious error, amounting to dereliction of duty, for him to stop his train after it had started and to have the flagman recalled.

While this accident was directly due to failure of employees properly to perform their duties, the signal system in use was entirely inadequate . . . and there was a deplorable lack of supervision on the part of operating officers.

The investigation of this accident justifies the following observations and conclusions:

The recurrence of disastrous accidents on this railroad and the large numbers of deaths and injuries resulting therefrom make advisable a less narrow treatment of the whole subject than that followed in mere inquests or in the ordinary official investigation of a train accident.

This commission has heretofore expressed in strong terms its condemnation of the management of this railroad. In the "New England investigation" (June 20, 1913) it said:

"If it were properly to be considered here, however, we would give weight to the suggestion that the merger has so overloaded the executive heads of the entire aggregation as to impair not only the correct and economical financial administration, but also the efficiency and safety of operation." . . . In reports on previous accidents on this railroad, defects of management, neglect of obvious precautions for safety, ineffective rules and . . . a general weakness of discipline, have been denounced and condemned. It is astounding that this state of affairs is allowed to continue to exist.

The directors of this railroad as shown in Poor's Manual for 1912 were:

William Rockefeller, New York, N. Y.	A. Heaton Robertson, New Haven, Conn.
J. Pierpont Morgan, New York, N. Y.	Frederick F. Brewster, New Haven, Conn.

George Macculloch Miller, New York, N. Y.	I. De Ver Warner, Bridgeport, Conn.
Lewis Cass Ledyard, New York, N. Y.	Edwin Milner, Moosup, Conn.
Charles M. Pratt, New York, N. Y.	William Skinner, Holyoke, Mass.
George F. Baker, New York, N. Y.	D. Newton Barney, Farmington, Conn.
Nathaniel Thayer, Boston, Mass.	Robert W. Taft, Providence, R. I.
Amory A. Lawrence, Boston, Mass.	James S. Elton, Waterbury, Conn.
Alexander Cochrane, Boston, Mass.	James McCrea, Philadelphia, Pa.
Charles F. Brooker, Ansonia, Conn.	Thomas De Witt Cuyler, Philadelphia, Pa.
George J. Brush, New Haven, Conn.	Henry K. McHarg, Stamford, Conn.
Charles S. Mellen, New Haven, Conn.	John L. Billard, Meriden, Conn.
James S. Hemingway, New Haven, Conn.	F. F. Maxwell, Rockville, Conn.
	Edward Milligan, Hartford, Conn.

The manual for 1913 shows the same list, with the exception that the names of Nathaniel Thayer, Amory A. Lawrence, George J. Brush, and James McCrea do not appear, and the following names have been added:

T. N. Vail, Boston, Mass.	A. S. May, Bridgeport, Conn.
S. W. Winslow, Boston, Mass.	Samuel Rea, Philadelphia, Pa.

On this directorate were and are men whom the confiding public recognize as magicians in the art of finance and wizards in the construction, operation, and consolidation of great systems of railroads. The public therefore rested secure that with the knowledge of the railroad art possessed by such men investments and travel should both be safe. Experience has shown that this reliance of the public was not justified as to either finance or safety.

In view of the focusing of public attention upon the question of safety in the operation of this railroad, and in view of the frequent governmental inquiries, both national and state, as to the causes of and remedies for the frequent disastrous accidents, it would seem as if the directors themselves would feel called upon to turn from the consideration of the financial questions in which this road is involved and for a time at least give the benefit of their consideration and judgment to the question of safety.

But the directors do not seem to have acted upon the subject until October 17, 1912, which was after the Westport wreck, which followed that at Bridgeport in July, 1911. They then voted that the president "should make the most searching investigation into the competency of engineers employed by the road," and "that nothing be left undone which, in the judgment of himself and his associates, will conduce to greater safety in the operation of the railroad, and that there shall be no limitation placed upon the installation of signals, safety appliances, or anything else which will in his judgment or that of his associates improve the safety of passenger travel upon this company's lines." The president was never apparently called upon, nor was any other official of the railroad, to present to the directors any result of such searching investigation as had been authorized, or to get any information as to what particular action had been or was to be taken to "conduce to greater safety."

The directors assumed to dispose of their whole responsibility on this subject by a vote depositing it in bulk upon the president, and thereafter, as far as appears from the records, made no further inquiry and took no further action, although in quick succession these disasters continued.

This typifies the whole situation. They assumed the vote was self-enforcing. The president, general manager, and superintendents issued orders that all rules should be obeyed, and that employees should take all precautions for safety. But no intelligent system was devised by which to ascertain when rules were disobeyed. Rules were disobeyed largely, and only a small proportion of these violations was made the subject matter of reports to officials.

Of some of the rules, as has recently been said by the general manager of this railroad when he issued new ones in their place, there had been "convincing demonstration" of their inadequacy.

Dereliction of duty by those who are charged with the making and with the enforcement of safety regulations can not fail to weaken respect for all rules and to render nugatory to a large

extent all efforts to maintain effective discipline. Rules that are not intended to be enforced have no proper place in a railroad company's code of regulations, and when the operating officers of a railroad permit rules which have been established to secure safety to be violated with impunity, they can not reasonably expect to escape responsibility for the consequences of such violations.

"Man failure" in this case began high up in official authority, and it was not an unnatural sequence that it reached down to those in positions lower in official rank, but still weighted with great responsibility. Discipline was weak and ineffective, certainly a fault of the management. Rules were inefficient, a fault of the higher officials. Rules were inadequately enforced, the blame for which must be charged to the officials. And while all this was true, high speed was required. And this high speed was required over the section of road where this accident occurred, while there were in use antiquated signals which were condemned by the locomotive enginemen as well as by the public service commission of Connecticut.

There was an imperative call arising from the density of traffic and complex operating conditions on this railroad for close and intensive superintendence. This call was unanswered until after the public hearing in this case. The proper spacing of the trains was a matter for which not the train employees but the management of the railroad was responsible.

It is not necessary here to attempt to outline the technical rule of law governing the obligation of directors as trustees for the corporation, for the aggregate body of their stockholders, and for the public. Suffice it to say that there can be little doubt that this legal obligation is more stringent than seems to be the generally accepted belief of many men of large fortunes who occupy many positions of this character.

The rule is that where a corporation is handling agencies dangerous to life, its directors are required to exercise such reasonable supervision over the management of their company's business as will result in the observance of the utmost care on the part of subordinates. Directors by law are not mere figure-heads, nor are their duties confined to the mere direction of the finances of a corporation. Their duties are such that mere delegation of them, if they are not in fact performed, does not satisfy the legal obligation unless there has been ordinary business care and diligence in supervision.

The duty of safeguarding against the hazards inhering in this business can not be divested from themselves by a mere vote delegating it upon another unless there is an exercise of the legal standard of care and diligence in supervision to ascertain and know that it is performed.

When public calamities call their attention to the nonperformance of the duty of safeguarding this enterprise, where governmental authorities call public attention to the necessity of further safeguards, it seems some further action by the directors of a railroad upon which such calamities are recurring is called for than a formal reaffirmation of a vote delegating the whole safety question to one official.

The safety problem of this railroad is primarily a question for itself. If governmental interference and action is called for it results from the inaction of the corporation itself. The Government, through the enactment of legislation by Congress, has the power, if this railroad will not itself exercise its own authority in the premises, to compel the safeguarding of traffic over this line.

By what we have said with respect to the duty of supervision resting upon the directors and the duty of managing officials to provide for the safeguarding of traffic we do not mean to palliate in any degree the disobedience of rules by the trainmen and enginemen hereinbefore named and commented on. When employees undertake the dangerous employment of railroading it is their duty to familiarize themselves with all the operating rules. Disobedience of these rules where they are specifically applicable carries with it full responsibility for consequences.

It can not be too strongly impressed upon railroad employees



that they are most strictly bound to comply with all safety rules provided by the railroad for their guidance. No matter how many contributing causes there may be for which others may properly be held answerable, the direct and proximate cause of this disaster was the failure of those members of these train crews before referred to to obey rules and to exercise the degree of care under the circumstances which was commensurate with the grave responsibility resting upon them at the time.

Our reference to the management of this railroad in the past, of course, has no application to the new president, who was confronted with this accident on the day he took charge. Presumably he was selected because of his ability and fitness as a railroad manager. It is to be hoped that he may be permitted to devote himself primarily to the problems of safety of operation which this railroad management is now under the highest compulsion of duty and humanity properly to solve.

Congress has made it the duty of this commission to investigate and report upon railway accidents and to make such recommendations as circumstances may require, but there has been no legislation by which such recommendations may be enforced. It is manifest that so long as compliance with the commission's recommendations remains discretionary the entire subject of safety of operation must remain dependent only upon the carrier's volition. The ignoring in whole or in part by carriers of such recommendations and the resulting fatalities, potently argue that safety of operation should not be left entirely to the discretion of any railroad, but, in the light of recent disasters, would seem to be a subject over which Congress well might exercise its full authority, including the fixing of some definite time within which all high-speed passenger trains shall be required to be made up exclusively of all-steel cars. Such recommendations as the commission may deem proper in these premises will be submitted to Congress in the commission's forthcoming annual report.

The density of traffic on this railroad requires an adequate block-signal system, and until the system now being installed between Springfield and New Haven is available for use an adequate method of providing a proper space interval between trains should forthwith be placed in operation.

Definite instructions should be issued to enginemen and trainmen to approach signals in weather so foggy or stormy as to obscure in any degree the clear view of signals with train under full control. Such instructions should also be enforced.

An adequate system of superintendence and supervision should be immediately arranged which will give those in authority definite and positive information as to whether or not the safety requirements and rules of this railroad are observed.

**ENGLISH BAGGAGE RATES INCREASED.**—An increase in the charges for excess baggage, passengers' baggage in advance, carted baggage and bullion and specie, to take effect January 1 next, is announced by the English railway clearing house. The notice is issued on behalf of all the railways of the United Kingdom represented by the clearing house, and a separate notice is published by the South Eastern & Chatham. In July, the managing committee obtained the provisional sanction of the Railway and Canal Commission to substitute the clearing house scale of parcels at company's risk for the very low scale then prevailing on its system, and also to raise the owner's risk parcels rates. The increase in both cases was about 4 per cent., and the new scales were put in force on August 1. Like the other railways, the South Eastern & Chatham now proposes to raise the present parcels rates for bullion and specie by 25 per cent., the charge for passengers' baggage in advance from 24 cents to 27 cents per package within the usual free cartage area, and from 30 cents to 33 cents per package outside such area, and the charge for carted baggage from 12 cents to 18 cents per package. For ordinary excess baggage the present rates per pound in England and for traffic between England and Scotland are: Up to 50 miles  $\frac{1}{2}$  cent, 51 to 150 miles 1 cent, 151 to 300 miles  $1\frac{1}{2}$  cent, and over 300 miles 2 cents per lb.

## CONNECTICUT REPORT ON NORTH HAVEN COLLISION.

The Public Utilities Commission of Connecticut has issued the report of its engineer, C. C. Elwell, on this collision, and supplements the report with its own conclusions, from which we quote as follows:

"We feel it but just to state in connection with this accident that the officers of the company exercised extraordinary care and caution in preparation for handling the heavy travel anticipated over Labor Day by issuing bulletins and special warnings and instructions to all men operating trains.

"The two trains involved in this accident were made up entirely of wooden cars. What would have been the result if of steel construction is more or less problematic, but it is generally conceded that steel cars should be substituted for the wooden cars as rapidly as possible. This, however, may be found to require heavier roadbed and bridge construction to sustain their additional weight. . . . All express trains operated over the New Haven system in Connecticut are interstate and in the matter of type of construction come wholly under the supervision of the Interstate Commerce Commission. . . .

"The question of automatic train control was very carefully considered by 'The Block Signal and Train Control Board' of the Interstate Commerce Commission and is now a subject of careful study and investigation by a number of leading railroads . . . but mechanical devices can never entirely take the place of men who are true and loyal to every duty.

"The existence of harmony, loyalty and strict discipline is absolutely essential for the safe and successful operation of trains. There appears to be a general feeling, more or less well founded, that these elements are lacking on the New Haven system between the company and its several classes of employees.

"The commission will not at this time, with only a limited investigation, undertake to state the cause or prescribe the remedy, but the following facts as to past conditions may have had their influence and may suggest at least a partial remedy:

"In 1898 the system was divided into nineteen divisions, each in charge of a superintendent.

"In 1901 the number of divisions was reduced to twelve; in 1908 the number was further reduced to seven, and about a year later to six. The average number of miles of main line handled by a division superintendent is now 332.89.

The Shore Line division, where this and other recent serious accidents occurred, had on September 2, 1913, 424.26 miles of main line, made up of single, double, four and six track sections, a total of 763.51 miles of main track, on a single track basis, with 464.40 miles of yard and side tracks. The total number of employees under the Shore Line division superintendent, including all classes of service, was 8,506, the superintendent being assisted by eight trainmasters who reported to and received instructions from him.

"The result of enlarging the divisions and reducing the number of superintendents has had a tendency of removing personal contact and lessening the friendly relationship between the directing and operating forces.

"Changing of divisional lines made it necessary to change train terminals and many employees who formerly had established homes were obliged to change their places of residence or 'live on the road' and be deprived of the beneficial influence of home life and environments. In cases where employees reside at a considerable distance from terminal points, much time, supposed to be and really required for rest, is occupied in 'dead-heading' to and from their homes. Engineers who knew only one section of the road were required to extend their runs and to 'break in' on new territory. Many station agents and their assistants have become dissatisfied by being forced to work short handed and with inexperienced help, in order to 'keep down expenses.' . . ."

**ANALYSIS OF A BROKEN RAIL.**

Louisville & Nashville passenger train No. 7, southbound, was derailed October 1, 1912, near Hays Mill, Ala., resulting in the death of the express messenger and the injury of 21 passengers. This train consisted of nine cars and the cause of derailment was a broken rail. The Interstate Commerce Commission has issued a report by the chief inspector of safety appliances and by James E. Howard, engineer-physicist of the Bureau of Standards, from which the following is taken.

The fractured rail was of 80-lb. section, 33 ft. long, of open hearth steel rolled by the Tennessee Coal & Iron Company in June, 1906, and laid that fall. The receiving end of the rail remained intact for a length of 13 ft. 4 in. The leaving end was broken into a number of fragments varying in length from 36 in. to 7¼ in., 18 of which were recovered. The rail was fractured across its entire section at 14 places. At 11 of these places the metal of the head disclosed transverse fissures ranging in diameter from 0.37 to 2 in. At only three of the complete fractures was the metal exempt from the presence of these transverse fissures, which were located either on the gage side of the head or directly over the web, none being present in the outer half of the head. The minimum distance apart of adjacent fissures was 7¼ in., and the maximum distance 36 in. In turning down a section of the rail for a tensile specimen the section fell apart in the lathe when the outer metal had been turned away for a distance, disclosing another transverse fissure, while one more was found in the head of the long section of the rail when bending the head. This latter fissure had a diameter of 0.37 in. and reduced the ultimate strength of the head 36 per cent. from that shown by a corresponding bending test on a section where no internal transverse fissure existed.

The chemical specifications under which this rail was rolled, the mill analysis and the Bureau of Standards analysis of the material are as follows:

	Specifi- cations Per Cent.	Analysis of Rail.			
		Mill Analysis Per Cent.	Top of head. Per Cent.	Center of head. Per Cent.	Upper part of web. Per Cent.
Carbon .....	0.55-0.68	0.57	0.88	0.85	0.84
Phosphorus .....	(not over) .06	.057	.051	.052	.048
Silicon .....	(not over) .20	.008	.014	.014	.019
Manganese .....	.80-1.10	.88	.68	.67	.67
Sulphur .....	.....	.040	.035	.032	.031

In discussing the rail Mr. Howard states that "it appears from the above that the carbon content of this rail was 23 per cent. higher than the upper limit of the specifications and 47 per cent. higher than the steel was reported, thus nullifying the value which might attach to the reported composition of the steel and giving such report a perfunctory character.

"Structurally the metal of this rail appeared uniform and sound. Cross sections polished and etched at six places along this length were uniform in appearance and substantially free from the dark markings which are frequently displayed by rail sections. So far as could be judged the formation and extension of these 13 transverse fissures was the result of service conditions to which the rail had been exposed in the track, not materially influenced by inequality of the steel.

"The combined bending stresses and intense wheel contact stresses which attend service conditions of a steel rail appear to constitute the features which lead to the formation and development of interior transverse fissures. Regardless of the grade or quality of the steel there must be present longitudinal strains which cause the separation of the metal of the rail in a longitudinal direction. The magnitude of those strains necessary to cause rupture will be greater or less according to the grade of metal.

"The effect of repeated alternate stresses in causing rupture in all grades of steel, without the display of ductility and under the action of fiber stresses somewhat below the elastic limit of the metal, is known. Repeated alternate bending of a steel

rail, and all rails are exposed to repeated alternate bending stresses, has a tendency to cause ultimate rupture in a brittle manner under fiber stresses below the primitive elastic limit of the steel. But exposure to bending stresses alone—that is, unaccompanied by intense wheel pressures on the running surface of the head—would lead to fractures which would have their origins at the fibers most remote from the neutral axis of the rail, where the stresses would be the greatest. Under such circumstances rails would be expected to fracture, starting either at the running surface of the head or at the under-side of the base.

"Since transverse fissures have their origins at the interior of the head and are longitudinal tensile fractures of the metal, it is necessary to look for a cause for the transference of the incipient place of rupture from the outside fibers to interior ones. The cold rolling of the running surface of the head by the wheels doubtless occasions this transference. The gage side of the head is most affected by the wheel loads, and that should be the side of the head to develop interior fissures, as examples of fractured rail have shown it to be.

"The effect of the wheels is to put the metal at the running surface of the head into a state of internal compression. The springing of the head into convex shape on the running side, when detached from the web, is evidence of the release of internal compression. The present rail sprung in that manner when the head was detached from the web. Herein is found a cause which has a tendency to transfer the incipient place of rupture from the surface to the interior of the head. The metal in compression at the running surface must perforce put the metal next below it in a state of tension and augment the tensile strains of the bending loads. In a way the rail is an example of unsymmetrical loading, or rather presents an unsymmetrical result of loading, with bending stresses alone affecting the base, while the head is affected by the combined bending stresses and internal strains of compression.

"It is not a question of grade of steel whether or not this action takes place, but in specific cases a question of what constitutes an overload for the particular steel being used. Rails which develop this type of fracture have certainly been overloaded. The close proximity of transverse fissures to each other precludes the explanation that they are the result of bending stresses taken alone. The results call for the presence of an independent force, the influence of which is felt along the entire length of the head, and such in fact is the manner in which the compression metal acts.

"Since these fissures occur in planes at right angles to the direction in which the rails were rolled their formation would not be looked for as a result of mill practice. Certainly the presence of fissures approaching 2 in. diameter would not be attributed to the action of the rolls of the rail mill, ignoring the fact, for the time being, that such fissures are located on one side only of the head. There is lack of continuity in steel in the ingot at places where slag inclusions exist, yet such globules, of one one-hundredth of an inch diameter, more or less, are drawn out in the finished rail into longitudinal filaments parallel to the length of the rail. The examination of rail steel through the successive reductions from the ingot to the rail has failed to furnish examples of incipient fissures developed at right angles to the direction of rolling.

"No method has been found capable of locating incipient interior fissures and which, it should be remarked, do not present oxidized surfaces. But so grave a matter as this should not be left in its present state of uncertainty, and data upon contributory causes, track conditions, wheel loads, and grades of steel in which these fissures appear should all be acquired. Primarily the formation of a transverse fissure is the result of an overload, for that particular rail, from whatever point the subject is viewed. It is regarded as an imperative duty, which should at once be performed, to ascertain and define the actual stresses to which the rails are daily subjected."

### ELECTRIC CARRIER SYSTEM.

The electric carrier system is a device now being perfected to transport mail or moderate sized packages in large buildings, such as terminals, warehouses, etc., or between any points either within or outside of cities. It is exceedingly rapid and of large capacity. Two of its chief advantages are its simplicity and durability.

The system consists of three-phase, alternating current cars, running on rails through a steel or concrete tube which may be built either on the surface, on trestles, or underground. The cars are propelled by a magnetic push or pull caused by the reaction of a progressive magnetic field in an elongated motor member rigidly fixed to the track between the two rails acting on a flat motor member secured to the bottom of the car. The current is transmitted to the car by means of two overhead trolley tracks.

This system permits of the utmost simplicity in the construction of the cars as no rotary motors are necessary and there is no wheel drive. The cars are operated entirely from a central power plant, and as they all travel at a uniform speed, corresponding to the number of alternations or cycles of the power circuit, they can be run at intervals of a few seconds without danger of collision. The cars can also be run in trains, thereby materially increasing the capacity of the system. Any curve or grade that would be necessary in practical operation can be negotiated with ease and it is believed that on a long level tangent a speed of 100 miles an hour can be attained.

For the purpose of demonstrating to the government the prac-



Arrangement of the Electric Carrier Within the Rings.

tibility of the system for the rapid transportation of mails between terminals in large cities, a plant has been installed at Paterson, N. J., which was so designed as to comprise all the operating difficulties that would ordinarily be met with in practical operation. This plant, which is shown in one of the illustrations, consists of a 1,000 ft. circuit with two straight stretches and two curves having a 40 ft. radius; track connection with the central power house, which is also used as a terminal; and track connection with a trestle hump having a grade of 20 per cent. A portion of the track is completely enclosed in a steel tube, but the greater part is circled by rings so that the cars can be seen in operation. The track is laid with 16-lb. rails and the gage is 12 in. The diameter of the tube and rings is 36 in. The rings are two feet apart and each is fastened to a tie. The

cars weigh 1,100 lbs., and their inside length is 6 ft. The only springs on the car are under the trolley wheels and on the buffers. The wheels under the car are held rigidly in position to keep the clearance between the two motor members uniform. This clearance varies from 1/8 in. to 1/2 in., but is usually 3/16 in. As the motor member on the track is tightly bolted at intervals of two feet and as there is no play to the motor member on the car the clearance varies only to a negligible degree. The wheels are on ball bearing axles, each wheel acting independently of the others. Empty or loaded, the cars run around the main circuit at the rate of 30 miles an hour. They were

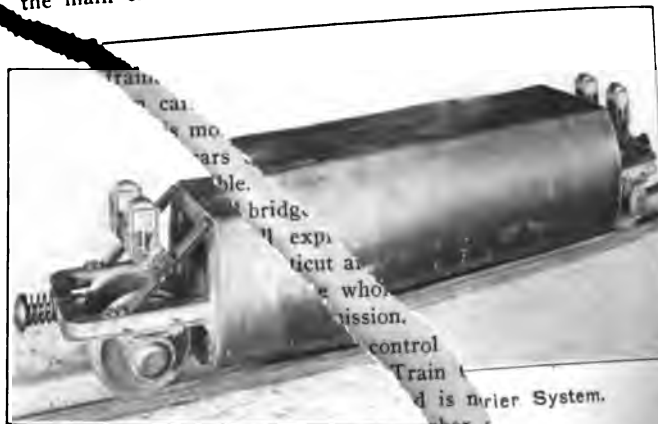

Car Used in the Electric Carrier System.

designed to carry a 300-lb. load, but it has been found that they can carry 1,000 lbs. equally well.

The 20 per cent. grade is negotiated with ease if the power is with the 1,000-lb. load. It was found that when a car is to climb the grade the car will only climb one-third of this hump if the power is cut off at the base, and also that the car can be stopped by reversing the power from the central power house, and reversing the power for a moment or slowing down the voltage. The voltage used for the level stretch is 150 volts, and for the grade, 300 volts. By means of transformers at the bases of the grades the voltage can be changed automatically. At the top of the hump two of the wires of the three-phase alternating current system are crossed so that on the down grade the cars will not gain added momentum. The cars can be operated equally well in either direction. In case of an emergency the cars are automatically released and the cars instantly stopped. In practical operation the cars will be switched to side tracks at terminals to be loaded and unloaded. No power will be used for these side tracks, as the cars can be easily pushed from the platforms. The cars will be stopped by means of friction from convex boards laid close to the rails which press against the bottom edges of the cars. When they are ready to start they can be pushed on to the main circuit.

The circuit at Paterson has been divided into blocks, and an automatic signaling system the location of the cars is shown on a plan of the circuit on ground glass in the station. As a car enters a block a light shows at the corresponding point on the plan and remains lighted until the car enters the next block, when it goes out and a light is shown at the plan at beginning of the next block. By this arrangement the location of any tie-up, due to a broken rail or damage can be immediately located and the cars behind can be stopped to avoid further damage. Each block can be controlled by a separate switch so that, in case of an accident cars in front can continue on their journey and the cars at the point of trouble can be brought back to the terminal which they started. In practical operation there will be a hole at every block so that the various sections can be inspected.

Maintenance costs should be low. The cars are sturdy built and so simple that there is very little to get out of order.

The track is protected from the elements by the tube, and the wear on the rails will be slight because there is no wheel drive and the grinding on curves will be minimized by the fact that the wheels revolve independently of each other. Operation will be cheap because only a small staff will be necessary and the power will not be expensive.

The cost of the installation of this system with two tracks running through 36-in. tubes, completely equipped, from New York to Philadelphia, Pa., 90 miles, has been estimated as follows:

Pipe in position .....	\$5,702,000
Power house .....	109,000
Right of way and trenching .....	540,000
Structure in the pipe (including rails, trolley tracks and motor member) .....	1,900,000
Block signals .....	100,000
Cars and trailers .....	23,000
	<hr/>
	\$8,375,000
Profit (15 per cent.) .....	1,236,000
	<hr/>
Total cost .....	\$9,611,000

According to these figures the cost is a little over \$50,000 a mile, but the estimates are said to be high rather than low.

## SIGNALING CONDITIONS ON THE PENNSYLVANIA.\*

By A. H. RUDD,

Signal Engineer of the Pennsylvania Railroad.

To insure the accuracy of the indications, we are installing all our new automatic work with alternating current track circuits, because we find that current from trolley lines interferes with our direct current track circuits. There are precautionary measures that can be taken with d. c. circuits, such as double relays and cutting circuits up, which have been tried with fair success. The real cure for the foreign current is the a. c. track circuit, and we are not only installing all new work that way, but changing over some of the old. This carries with it electric lights on the signals, and a. c. motors.

The cost of installation is heavy. It runs for double track about \$3,000 per block, 4,000 or 5,000 or 6,000 ft. long; for the two tracks probably \$8,000 a mile. I suppose some of the cost will come out of the 5 per cent. advance in freight rates!



Electric Carrier System Demonstration Plant at Paterson, N. J.

When they were made it was thought that an elongated motor member would be necessary between the trolley tracks as well as between the rails. It has since been found that one motor member between the rails is all that is necessary. This should reduce the cost of the structure in the pipe materially. The average cost of cars and trailers is about \$100 each. The estimated cost of the installation of the system, with two 36-in. tubes, underground from the Grand Central Terminal, New York, to the Pennsylvania Station, is \$600,000.

According to the estimates submitted to the government, the full capacity of the last mentioned installation, running single track at intervals of 20 seconds, would be 8,640 mail pouches per day. This capacity could be doubled by attaching a trailer to each car, and could be quadrupled by running trains of two cars and two trailers at intervals of 20 seconds. The maximum capacity, therefore, would be 34,560 mail pouches per day.

The system can be adapted to transport cars small enough to be used in large stores or large enough to run on standard-gauge tracks. The principle could also be used for escalators and even elevators.

The system is being developed by the Electric Carrier Company, New York.

Operating and maintenance costs are below anything we have had before. For electro-pneumatic signals the cost of maintenance is about \$160 a year per block. That on a four-track road, is \$640 a mile. The d. c. motor runs about \$90, and in some fortunate cases we have had \$75 quoted, but we are from Missouri. The a. c. runs not over \$60. That means a saving of \$400 a mile over the old electro-pneumatic.

On single track in places we are using the controlled manual block, where we have a stretch of single track in a double-track line and the track is pretty hot and we have had to issue a great many orders. We put in this controlled manual, with the continuous track circuit, so that both the signalmen and the track circuit have to go wrong and the trains go wrong also before we can get them together. We are moving the trains in such places without orders, and saving a great deal of delay. The delay of holding freights for orders often knocks them out of their running time and holds them back an hour or two. With this scheme they can skin through without time table rights. We are using it on a third track in some places, and we are contemplating putting it on the two inside tracks in our four-track line in a few places so we can use three

\*Extracts from an address before the Railway Club of Pittsburgh.

tracks in one direction under signals during certain parts of the day, and in the other direction during other parts of the day.

At interlockings we have elaborate electric locking. This has been developed from small beginnings. First, to obviate deficiencies of detector bars we installed electric switch locking so that when the train is on the switch it could not be moved. The train shunted the circuit and locked up the lever. Then we extended it to take in the fouling points. Then we extended it to lock the switches ahead, so that even if the switchman put the signal normal the switch would be locked until after the train passed over.

That was all right if you ran in one direction. When we tried to run a train in the other direction we could lock them up, but the switch farthest ahead, that we did not want to unlock, was the first one to unlock, and those we wanted to unlock first were the last to unlock. Mr. Anthony, assistant signal engineer, solved that problem.

After we got the switches locked up we had a case where an engineman reported that he had a clear distant which changed to caution just in front of him. He stopped just short of the home signal and found a train crossing over in front of him. Then we arranged the locking so that when a train entered the circuit 3,000 or 4,000 ft. from the distant signal it locked the levers so, though the signals could be put to stop, the route could not be changed until he had passed the home signal. That was a long step in advance. To provide for a train shifting we put in a slow release, with which two or three minutes would be required to change the route. If a man consumes three minutes between the distant and home he can stop, if the home is against him. As a substitute we used a time release, so arranged that after a signal was put normal it would take two minutes to change the route. That means that after the engine has passed it will take two minutes to let him into the siding. Recently we have developed a scheme so that we can use the time lock if the train is approaching, but release as soon as it has passed the home; so we get the quick release of the approach locking and the economy of the time locking.

For our four-track interlocking and other construction and maintenance we have appropriated this year \$4,200,000.

On our Manhattan terminal, which is the best signaled piece of railroad in the world, we have automatic signals through the Hudson river tunnels in both directions, and we have automatic stops. The signals are so arranged that by throwing a lever in the big cabin at the terminal, and another at the Hackensack drawbridge, five miles away, we can reverse the traffic. If trains have been running west and have passed out of the block we lower all the automatic stops and put them out of business for westbound trains, and throw into service the automatic stops and signals for eastbound trains. We operate two or three trains that way daily in order to be sure that everything is working properly. That is the only place where we use the automatic stop. The one we are using is the Hill automatic stop, and is comprised of three parts, like all Gaul. The first part was invented by Mr. Kinsman, as near as I can get at it, and the Union Switch & Signal Company arranged for its use. I may not be right. I do not want a libel summons, but that is what I have heard. They have adapted it to the electro-pneumatic cylinder, which Mr. Kinsman did not invent. We decided that we would not put stops outside because the interference with snow and ice might be troublesome. The principal object was to prevent the angle cock on the train, which when hit opens the train line, from being interfered with by lumps of coal and crossing planks and things of that kind lying along the road. So we decided to install it in the tubes only. The committee made their recommendations to the committee on yards and terminals. And they approved it. Then it was put up to the big committee, the joint committee on the operation of the yards and stations

and structures. They approved it. With all that tremendous influence back of it, it is no wonder that the vice-president and the president approved it. We equipped all our electric locomotives and all our multiple unit power and sent a trial train out on the Long Island. The first trip it struck a piece of crossing plank and got stopped; and then we made the discovery that even if we had only put the trips in the tunnels the trains that ran outside might hit things. We did not reach this conclusion by synthesis or analysis, but by hard knocks. Then Mr. Hill started to see if he could develop something, and he did.

It is a mighty ingenious proposition and is working with very satisfactory results on our trains today. So when some people tell us there is no satisfactory automatic stop we have to say that if you want that kind of thing we have just the kind of thing you want. I don't believe we want it for general use for a good many years. Where you have mixed traffic it will tie up your railroad. The conditions on the Interborough and in our tubes today are ideal for an arrangement of that kind. Trains are run at approximately the same speed and the same spacing in the rush hours, and the same class of trains and equipment, high-class passenger trains, no slow drags or shifting movements.

After we have got our roads signaled with what money we have left, after we have paid the income tax and the other taxes and the excessive expenditures which we are compelled to pay because of new laws; after we have got rid of all the grade crossings in New Jersey at our own expense and done a few other little things that need fixing, and have tried out discipline; and our safety committees have done their work; and after the enginemen have become awakened to the honor of their profession, and to the fact that good men are being imperilled when the careless and slovenly men are protected and backed up; after the men get so that they feel that they should weed out the poor men—and there are a few—with the improved discipline and improved feeling, 99 out of 100 of the accidents and collisions which might be prevented by automatic stops will be eliminated. After we have done all of those things, if our safety first movement will not take care of the balance then I think the time will come to try, not automatic stops which apply the emergency, but a speed control that will take care of the speed as soon as it reaches a given limit.

PASSENGER TRAFFIC IN THE UNITED KINGDOM.—The returns for the railways of the United Kingdom for 1912 show that the total number of passengers carried, excluding season-ticket holders, was 1,294,337,000, as compared with 1,326,317,000 in 1911. The abolition of second-class fares on a number of the railways caused a very large transfer of passengers to the third class, but, nevertheless, there was a decrease in the number of third-class passengers of 21,216,000. There was a loss of 10,612,000 in the number of second-class passengers and a slight falling off in the number of those paying the highest fares. A partial explanation, at least, of the decrease in the number of passengers carried in 1912 was the disorganization of the railways for some weeks by the great coal strike. A further explanation, which will evidently be more potent as the years pass, was the increase in the motor-omnibus and tramway services and the wider use of motor cars generally. In 1910, for example, the third-class railway passengers in the United Kingdom showed an increase of 43,000,000 over 1909, while the tramways showed an increase of 163,000,000 for the same period. In 1911 there was an increase of 21,000,000 in the number of third-class passengers carried on the railways of the United Kingdom, but there was an increase of 220,000,000 in the number of tramway passengers. Effort is now being made to establish what is designated as a greater omnibus service between London and the important towns and resorts within a radius of 50 miles from the metropolis. Extensions of omnibus routes are also taking place in many other parts of the United Kingdom.

**TRAIN ACCIDENTS IN AUGUST.<sup>1</sup>**

Following is a list of the most notable train accidents that occurred on railways of the United States in the month of August, 1913:

*Collisions.*

Date.	Road.	Place.	Kind of Accident.	Kind of Train.	Kil'd.	Inj'd.
12.	Chicago, R. I. & P.	Richfield.	rc.	P. & F.	0	43
13.	Wabash	Millard.	bc.	P. & F.	1	7
23.	St. Louis & S. F.	Newburg.	rc.	P. & P.	0	26
†24.	Georgia	Decatur.	rc.	F. & P.	1	37
24.	Oregon S. L.	Virginia.	rc.	F. & F.	0	1

*Derailments.*

Date.	Road.	Place.	Cause of Derailm't.	Kind of Train.	Kil'd.	Inj'd.
5.	Wabash	Runnels, Ia.	cow.	F.	1	2
5.	Central Ga.	Oliver.	acc. obst.	P.	0	14
6.	Nashville, C. & St. L.	Marietta.	flood.	F.	4	0
8.	Texas & Pacific	Mingo.	unx.	F.	4	1
14.	Chi., M. & St. P.	Burgoyne.	boiler.	F.	2	2
†19.	Great Nor.	Crary, N. D.	d. eq.	P.	2	36
19.	St. Louis & S. F.	Jensen, Ark.	unx.	P.	0	17
21.	Illinois C.	Bogue Chitto.	d. frog.	P.	0	3
22.	Penn.	Leetonia, O.	d. truck.	P.	0	8
23.	St. Louis, I. M.	Marche.	burnt bdge.	F.	1	2
26.	Ches. & Ohio	Bremo.	bad load.	P.	..	16
27.	Toledo & O. C.	Peoria.	neg.	F.	1	0
28.	Galv., H. & S. A.	Harwood.	exc. speed	P.	0	15

The trains in collision at Richfield, Neb., about midnight on the morning of the 12th, were an eastbound train carrying a circus and passenger train, second No. 6. The circus train had entered the side track to be passed by the passenger train, but had not cleared the main line, and had not flagged the passenger train. Forty-three employees of the circus were injured.

The trains in collision at Millard, Mo., on the 13th, were northbound passenger No. 1 and a southbound freight. The passenger ran over a misplaced switch and into the head of the freight, which was standing on a side track. The engine-man of the freight was killed and the fireman and six passengers were injured. The responsibility for the collision is laid on the head brakeman of the freight train, who became confused and threw the switch for the siding. This man soon after disappeared.

The trains in collision at Newburg, Mo., on the 23rd, were eastbound passenger trains. Twenty-five passengers and one employee were injured. The cause of the collision was the failure of the flagman of the leading train to protect by flag.

The trains in collision near Decatur, Ga., on the morning of the 24th, were westbound passenger No. 3 and westbound freight No. 19, the freight running into the passenger just as it was starting away from the station. One passenger was killed and 37 were injured. The freight engine penetrated the rear car of the passenger train about 5 ft. The freight train had encroached on the time of the passenger.

The train derailed near Runnels, Iowa, at 4 a. m. on the 5th, was an eastbound freight. The fireman was killed and two other trainmen were injured. The engine of the train was overturned and ditched by striking a cow.

The train derailed at Oliver, Ga., on the 5th, was eastbound passenger No. 4. Nine passengers, two trainmen and three other persons were injured. The cause of the derailment was some accidental obstruction in a frog after the engine had passed it safely.

The train derailed near Marietta, Ga., on the 6th of August, was a fast southbound freight, and the engine and 14 cars were wrecked. Three trainmen and a trespasser were killed. The

derailment occurred at 1 a. m., and was due to the destruction of a reinforced concrete culvert by a flood.

The train derailed near Mingo, Tex., on the 8th was a northbound freight of the Missouri, Kansas & Texas, and 13 cars were ditched. Two trainmen and two trespassers were killed, and one trainman was injured. The cause of the derailment was not discovered.

The train derailed near Burgoyne, Mont., on the 14th, was a westbound freight, and the cause of the derailment was the explosion of the boiler of the locomotive, due to low water. The conductor and the engine-man were killed and the fireman and one brakeman were injured.

The train derailed at Crary, N. D., on the 19th, was the westbound Oriental Limited. Two tramps were killed and 35 passengers and one employee were injured. The smoking car was forced violently against a grain elevator, partly demolishing the building. The wreck took fire from coals in the locomotive; and the mail car, baggage car and two passenger cars were damaged by fire. The cause of the derailment was the breakage of the equalizer between the driving and trailing wheels of the engine, the parts of which fell to the track.

The train derailed at Bogue Chitto, Miss., on the 21st, was a northbound passenger. The tender jumped the track at a frog and the first two cars fell down a bank. Three passengers were injured. The cause of the derailment was a defect in the frog.

The train derailed near Leetonia, Ohio, on the morning of the 22nd, was eastbound passenger No. 8 and eight passengers were injured. The cause of the derailment was a broken spring hanger in the truck of a passenger car.

The train derailed at Marche, Ark., on the 23rd, was an eastbound freight. The engine-man was killed and two other trainmen were injured. The cause of the derailment was the weakening of a bridge by fire, the location of the bridge being such that the engine-man, approaching it, did not see the danger. The wreck took fire and five loaded cars were burnt up.

The train derailed near Bremo, Va., on the 26th, was a freight and passenger combined, eastbound. The conductor, the porter and 14 passengers were injured. Two passenger cars and three freight cars fell down a bank. The cause of the derailment was the top heaviness of a carload of wood. It rocked off on a curve of 5 deg.

The train derailed near Peoria, Ohio, on the 27th, was a southbound freight. The engine-man was killed. The train entered a siding at uncontrolled speed.

The train derailed at Harwood, Tex., on the 28th, was passenger train No. 2. Thirteen passengers and two employees were injured, none seriously. Of the two engines drawing the train the leading engine remained on the track. The cause of the derailment was excessive speed.

**TRANSANDINE RAILWAY DIFFICULTIES.**—The Transandine railways have recently come in for a great deal of criticism and discussion in the Chilean senate in reference to differences arising with the Argentine Great Western and Buenos Ayres & Pacific. It is alleged that although the Chilean government grants a subvention of \$150,000 to the Chilean section of the Transandine railway, the tariffs imposed by the Argentine railways in question put rather a severe check on the movement of Chilean products entering into competition in the Argentine markets with similar products grown on the zone served by the two companies. The Chilean senators are not satisfied with the benefits resulting from passenger, postal and baggage transportation. They suggest that the only possible solution is the expropriation of the Chilean section by the Chilean government. Should this be achieved it is hoped that works to prevent the blocking of through traffic may be taken in hand. On the Argentine side the Buenos Ayres & Pacific has done everything to expedite traffic. On the Chilean side the hotel keepers benefit, since during a heavy fall of snow it is not possible to leave the Chilean borders.

<sup>1</sup>Abbreviations and marks used in Accident List:  
rc, Rear collision—bc, Butting collision—xc, Other collisions—b, Broken—d, Defective—unf, Unforeseen obstruction—unx, Unexplained—derail, Open derailing switch—ms, Misplaced switch—acc. obst., Accidental obstruction—malice, Malicious obstruction of track, etc.—boiler, Explosion of locomotive on road—fire, Cars burned while running—P. or Pass., Passenger train—F. or Ft., Freight train (including empty engines, work trains, etc.)—Asterisk, Wreck wholly or partly destroyed by fire—Dagger, One or more passengers killed.

## General News.

The state's attorney and the coroner at New Haven are reported as having decided not to begin any criminal prosecution of officers of the New Haven road on account of the North Haven collision.

The Missouri, Kansas & Texas is putting fire-extinguishing apparatus on about 100 locomotives in service in Oklahoma and Texas. Each engine will have a fire pump and 500 ft. of twoply cotton hose.

Governor Dunne, of Illinois, has asked the presidents of all railways in the state to send representatives to attend a conference in his office on Saturday of this week, to discuss the subject of grade crossing accidents.

"Safety First," as related particularly to the habits of trespassers walking along the tracks, is the subject of an article in the last *Outlook* by Marcus A. Dow, of the New York Central. The feature of the article is a series of striking pictures showing how all sorts of people make a thoroughfare of the railroad tracks.

A press despatch from Jackson, O., September 26, reported that, as the result of action of the State Inspector of Boilers in condemning twenty locomotives of the Detroit, Toledo & Ironton, the entire system between Jackson and Springfield, 111 miles, was at a standstill. Four hundred cars loaded with coal were lying in the Jackson yards.

A number of the shorter railroads of the southeastern states have formed an association with a view to promoting their mutual interests; and at Atlanta, September 23, an organization was formed with J. W. Oglesby, president of the South Georgia Railway, as president. C. B. Lucas, traffic manager of the Valdosta, Moultrie & Western, Valdosta, Ga., is secretary.

Two all-steel business cars to be used by officers of the Pennsylvania Railroad to transact railroad business while traveling, will soon be finished at the Altoona shops. By the use of the business cars last year Pennsylvania officers, while traveling 159,517 miles, were able to conduct the affairs of the railroad just as if they had been in their own offices. With these cars finished, the Pennsylvania will have four steel office cars.

Charles J. Doherty, the engineman who figured in the fatal collision at Stamford, Conn., June 11, died at his home in New Haven, September 26, the cause being heart failure. Doherty had secured employment, running a stationary engine, but his nervous system was broken down by his grief over the wreck. He could not sleep at night, and often kept his small children up because of his distress at being left alone. He leaves a widow and two children.

The office of the Weather Bureau at Washington has issued a memorandum concerning the floods which occurred in Ohio and Indiana last March and it is estimated that the total money loss by these floods was \$163,000,000. This includes loss to railroad, telegraph and telephone lines and to farms and farm property, including prospective crops. The latter alone amounted to about \$11,000,000. Of the total amount more than 70 per cent. was sustained in Ohio and Indiana.

At a meeting in Chicago on September 28, representatives of the Brotherhood of Railway Car Men, one of the organizations which struck on the Illinois Central and the Harriman Lines, two years ago, appointed a committee to go to Washington and present evidence concerning the strike to the new federal industrial commission recently appointed by President Wilson. Press reports are not entirely clear as to what it is purposed to accomplish, except that the commission is expected "to right industrial wrongs."

Train No. 7 of the Alabama Great Southern was stopped by robbers near Cottondale, Alabama, on the morning of September 26, and the mail car and express car were robbed, dynamite being used. The bandits, who are said to have been under 20 years old, detached the engine and express and mail cars from the train and ran them forward some distance. After finishing their robbery they started this part of the train forward, and then, jumping off, left it to run uncontrolled several miles. It stopped, however, without doing damage.

Special agents employed by the Illinois Central have discovered a new plan for getting money out of the treasury of the railroad. The company's trains have in the past few days killed two mules near Independence, La. Investigation showed that both animals had been tied to the tracks. The supposition is that the owners did the tying, and that they intended to file a claim against the railroad, but that their plans were defeated when they discovered that pieces of the rope had been found.

A conference was held at Chicago on September 24, between members of a sub-committee on weighing of the Committee on Relations Between Railways of the American Railway Association and the committee of the National Industrial Traffic League on weighing, together with J. T. Marchand, the attorney who represented the Interstate Commerce Commission in the weighing investigation. The conference was held for the purpose of bringing about an agreement on a number of rules regarding weighing matters covered in the recent decision of the Interstate Commerce Commission. With a view to defining more closely the points at issue the conference was adjourned to October 17, in New York, the day following the meeting of the Committee on Relations Between Railways.

Washington despatches report Commissioner McChord as engaged in drafting bills to be presented to Congress looking to more detailed regulation of railroads, in the matter of safety, by the federal government. Bills are also being drawn by one or more members of the House Committee on interstate and foreign commerce. This committee last week listened to the claims of a number of inventors of so-called safety devices. Chairman Adamson, of this committee, is reported as saying: "For five or six years we have been hoping the railroads would themselves take action without new legislation. At present the committee believes it may be proper to give the commission power to tell railroads when and where they must install safety appliances, block signals, steel cars, and make improvements in their roadbed. If railroads run trains too close together the commission might properly be authorized to stop the practice."

### A New Sub-head for the Expense Account.

According to press reports, the Lake Superior Terminal & Transfer Railway has been ordered to pay \$25 a month alimony to the divorced wife of one of its employees who was killed in an accident ten days after the divorce was obtained. The court had awarded the wife \$25 a month alimony and the State Industrial Commission has issued a ruling ordering the railroad to pay the amount in lieu of damages.

### Record-Breaking Monoplane Flight.

At Rheims, France, September 29, Maurice Prevost, flying over a circular course, in a monoplane, traversed a distance of 124.28 miles in 59 minutes, 45.6 seconds, or at the rate of 124.58 miles an hour. The length of the circular course is 6.213 miles, and Prevost made one circuit in 2 minutes 56.6 seconds.

### Association for the Reduction of the Number of Railway Accidents.

This is the title of an organization reported to have been organized at Berlin, Germany, by former railway employees. Its object is "to bring about improvements in signaling and safety apparatus and to encourage inventors by financial support." Members of the association include men and women. They will contribute as annual dues "any amount they can afford."

The foregoing is from a paper which prints "all the news . . ."—regardless, in many cases, of the obvious silliness of the alleged news.

### Lehigh Valley Employees' Relief.

The Lehigh Valley Railroad during the last fiscal year contributed \$56,991.34 to its Employees' Relief Fund, making the total amount paid into this fund during the year \$113,982.68. Three or four times a year—whenever the total amount in the fund drops below a specified figure—a call is made for contributions from all employees who wish to participate. There is nothing compulsory about it. Any employee may pay into it any sum up to the total of one day's pay, with a maximum of \$3. For every dollar an employee pays in, the company pays another dollar. It also agrees to assume all the bookkeeping and other

administrative expenses. The right to participate in the fund's benefits continues until a new call has been made.

A member who is hurt while at his duties will receive three-quarters of the amount he subscribed at the time of the call, for every day he is unable to work. A man who paid \$3 when the call was made will receive \$2.25 a day until he can go back to work. The widow or dependents of a member who is killed while working for the company will receive the same amount, a daily allowance of three-quarters of the amount paid in, for two years.

#### All Tramps Jailed.

The "Lake Shore push" is that vague horde of tramps and hoboes who line the tracks along the river and lake, vividly described in the books of "Josiah Flynt." They have had their way for many years, but at last a man has arisen with a plan for doing away with them. Police Judge Austin, of Toledo, has started in to give every vagrant that comes before him a flat sentence of 30 days. He is not asked to get out of town, for that means only trouble for some other municipality. The judge wants a conference of the cities from Detroit to Buffalo, to devise plans for systematic, drastic severity with mere tramps. Certainly the old scheme of merely urging the wayfarer on to the next town has not worked.

The tramp evil has been one to which we have submitted, because we have had it so long. There are many such evils, which the new growth of the cities will not endure. Judge Austin's plan for co-operation deserves to be considered by every city.—*Detroit Journal*.

#### A Railroad Commissioner's Platform.

Frank N. Julian, a member of the State Railroad Commission of Alabama, announces that he is a candidate for re-election, and in a long statement printed in a Montgomery paper, says:

"During my two and one-half years' service on the commission 118 cases have been docketed and disposed of; of this number 40 per cent. have been initiated by the commission. This only refers to cases docketed. The number of complaints filed and adjusted without formal hearings has been four times greater than ever before in the history of the commission. This is but one evidence that the commission is serving the people to a greater extent than ever before since its establishment.

"More new depots have been built and others renovated, repaired and improved than within the same period in the past.

"More passenger trains have been put into service and the schedules and train accommodations are much better than heretofore.

"Rates, both freight and passenger, have been equalized and put on a parity with rates of our neighboring states.

"Much hard work is before the commission, now that the courts have sustained our authority, and the commission is engaged in investigations to see that Alabama is permitted to enjoy 'equal rights,' in rates and service, with other states.

"In view of the vast amount of work now before the commission, and in sight, it may be that I will be prevented, by reason of my official duties, from engaging in an active campaign, but I feel that the official who is attending to the duties of the office which he holds will be given due credit, and that my friends will see that my interests are cared for in the approaching primary."

#### Railway Course at University of Minnesota.

The University of Minnesota has announced an evening course in railroad traffic and rates to be given at Minneapolis during the coming winter. It is designed to provide railway men and traffic clerks of shipping houses with instructions regarding the technical and detailed work of those who have to do with railroad traffic and rate making. The course will be under the direction of Professor G. A. Gesell, of the Department of Economics of the University, and Lee Kuempel, chief clerk of the freight traffic department of the Soo Line. Among the subjects to be treated are the following: Theory of Railroad Rates; Freight Classifications; "Make up" of Tariffs; Authorities under which Joint Tariffs Are Published; Rail and Water versus All-Rail Rates; Basis for Principal Present-Day Rates; Car Service and Efficiency; Accounting of Freight Revenue; Fast Freight Lines, Tariffs and Guide of Billing Books; Privileges; "Transit and Storage"; Principal Commodity Rates—Lumber, Grain Products, Live Stock, etc.; Conditions Govern-

ing the Proper Issuance of Bills of Lading; Tracing of Freight; Methods of Compiling and Presenting Claims; Conditions Imposed by Federal and State Laws on the Acceptance of Freight; Study of the Conference Rulings of the I. C. C.; Federal Control; Interstate Commerce Act of 1887, Elkins Amendments 1903, Hepburn Act 1906, Mann Act 1910; State Control: Conflict of Federal and State Control.

#### The Noise Nuisance.

A cartoon in the *Ohio State Journal* depicts a citizen in his bed trying to sleep, but he is disturbed by nightmares of noisy night freight trains; and the title of the picture is "Hell."

Fostorians are not so much disturbed by trains, because they run at night, but because of their conduct. The useless jangling of bells and the shrieking of whistles, whether by day or night, is what we have to complain of. These unnecessary noises are bad enough on the nerves of well people; how they affect the sick we can only conjecture. Railroads that act boisterously after dark can be disciplined just as easily as other nocturnal disturbers.—*Fostoria (Ohio) Times*.

#### The New Jersey & Pennsylvania.

Owing to lack of funds to make improvements and repairs ordered by the State Board of Public Utilities, the New Jersey & Pennsylvania Railroad (formerly the Rockaway Valley) running between Whitehouse, N. J., and Morristown, twenty-seven miles, has announced that it will discontinue operations after October 5.

Fredrick V. Pitney, of Morristown, receiver of the road, appeared before the Utility Board to explain that the Court of Chancery would not permit the issue of receiver's certificates, on the ground that such action would be unfair to the bondholders. The only way to raise money and continue the road, he said, would be by having somebody supply the money without security, and this no one was willing to do.

#### The Baltimore & Ohio Staff Meeting.

The meeting—it might be called a mass meeting—of officers of the Baltimore & Ohio, the announcement of which was noticed recently, was held at Deer Park, Md., September 22 and 23, about 300 officers being present.

President Daniel Willard, addressing his fellow officers, said, in part:

Since the staff meeting, held when the general scheme of improvements was adopted, there has been expended in betterments on the whole system \$100,000,000. Miles of new track have been constructed, mountains have been torn away to provide low grades, tunnels have been eliminated, safety appliances have been installed, and hundreds of passenger cars and locomotives of all types as well as thousands of freight cars have been added to the service.

As a result in part of this large expenditure the earnings for the last fiscal year were in excess of \$101,000,000. The company has spent \$40,000,000 in the betterment of the physical condition of the property, with about \$10,000,000 under way, and \$47,000,000 in the purchase of new equipment, station improvements and other work which brings the total expenditures close to \$100,000,000. With favorable conditions obtaining, the hope of the management is to continue this program at the rate of \$15,000,000 annually for the next five years.

The stock of the Baltimore & Ohio today represents an investment of 100 cents on every dollar. Drawing a parallel between the railroads and other business enterprises, Mr. Willard compared the rate of interest obtainable through investment in industrial and manufacturing securities and pointed to the fact that the railroads, in order to retain their position in the eyes of the investing public, must bear evidence of the stability of their securities from an investment standpoint. It is the policy of the B. & O. that any surplus above 6 per cent shall be returned to the property in the form of betterments. If for any reason there should be a failure on the part of the government to grant increases in rates, the railroads would be in exactly the same position as the head of a household desiring to make improvements, but lacking sufficient funds. It would mean, figuratively, that instead of putting on a new roof the leak would be patched and instead of renewing the fence the pickets would be repaired. Efficiency in the operation of trains and the handling



of tonnage means reduced cost of transportation. The average train load on the Baltimore & Ohio today is 680 tons, or an increase of 50 per cent. in three years. Economy in the use of material and supplies also means efficiency and such apparently trivial items as the saving of a single shovelful of coal by a locomotive fireman on each mile run would mean a large saving to the company in its fuel bills. . . .

#### Railway Earnings for 1912-13.

According to figures compiled by Slason Thompson, director of the Bureau of Railway News and Statistics, Chicago, the total operating revenues of the railways of the United States for the fiscal year ending June 30, 1913, amounted to \$3,171,445,992, and operating expenses to \$2,200,991,281. Taxes absorbed \$129,581,478, leaving a net income of \$840,873,233. This represents an increase of \$79,452,973 over 1912 in total operating revenues, but only \$4,940,945 over the net income of 1910. Meanwhile, over 10,000 miles of line, and 25,000 miles of track have been added to American railways.

Mr. Thompson's figures, with comparisons for the preceding two years, are as follows:

SUMMARY OF REVENUES AND EXPENSES OF THE RAILWAYS OF THE UNITED STATES.			
	1910-11.	1911-12.	1912-13.
Average miles operated.....	244,476	246,511	248,817
Operating revenues:			
Freight .....	\$1,925,950,887	\$1,975,747,267	\$2,211,814,665
Per cent. of earnings....	69.04	68.76	69.74
Passenger .....	657,638,291	663,838,648	703,251,936
Per cent. of earnings....	23.57	23.10	22.17
Other transportation .....	179,278,701	204,123,560	221,408,484
Per cent. of earnings....	6.43	7.11	6.98
Non-transportation revenue.	26,893,790	29,570,510	35,072,407
Per cent. of earnings....	.96	1.03	1.11
Total operating revenues.....	\$2,789,761,669	\$2,873,279,985	\$3,171,445,992
Operating expenses:			
Maintenance of W. and S. . . . .	366,025,262	364,865,825	423,872,363
Ratio to revenue.....	13.12	12.70	13.36
Maintenance of equipment. . . . .	428,367,306	454,197,495	520,677,293
Ratio to revenue.....	15.35	15.81	16.42
Traffic .....	59,166,364	61,254,807	63,723,219
Ratio to revenue.....	2.12	2.13	2.01
Transportation .....	987,382,128	1,036,724,407	1,116,553,224
Ratio to revenue.....	35.40	36.08	35.21
General .....	73,689,373	73,019,447	76,194,182
Ratio to revenue.....	2.64	2.54	2.40
Total operating expenses.....	\$1,915,054,005	\$1,990,061,981	\$2,200,991,281
Ratio to revenue.....	68.64	69.26	69.40
Net operating revenue.....	874,707,664	883,218,004	970,454,711
Ratio to revenue.....	31.36	30.74	30.60
Net revenue from outside operations .....	1,815,193	1,243,319	1,576,103
Taxes .....	108,219,512	121,797,743	129,581,478
Ratio to revenue.....	3.88	4.24	4.09
Net operating income.....	768,303,345	762,663,579	842,409,336
Ratio to revenue.....	27.55	26.53	26.56
Per mile of line.....	3,143	3,094	3,384
Permanent improvements.	62,685,878	52,369,258	Not reported yet

In commenting on the results shown for the year Mr. Thompson says in part: "Once more the revenues of the railways of the United States show a normal increase for the year attended by such an abnormal increase in operating expenses and taxes as to result in a net income wholly inadequate to meet the pressing transportation demands of the American people. It is difficult, however, to impress the popular mind with the idea that anything can be badly out of joint with an industry whose gross annual earnings show continuous gains and have to be expressed in terms of billions of dollars. Every month and twice a year the press records record revenues in the headlines on the front page, and buries the operating cost and net figures among the reading notices on the financial page.

"As a result ten persons know that the gross revenues of American railways now exceed \$3,000,000,000 annually where one ever learns that operating expenses and taxes are in excess of \$2,250,000,000."

#### A Revolution to Cure a Single Evil.

The *Springfield Republican*, in a comprehensive editorial on the North Haven collision report, discusses present tendencies as follows: "The Interstate Commerce Commission's remedy for 'man failure' is closer government control and regulation of railroads. The most important part of the McChord report is the intimation that the commission will recommend to Congress the enactment of new laws conferring specific authority upon the commission to regulate train operation.

"The question of train safety is already conspicuous as an item in the program of Congress at the coming winter session.

How far will Congress go in substituting the Interstate Commerce Commission for the general manager? Spurred by a public sentiment outraged by the manslaughter on the New Haven system, Congress may easily go too far in this direction. The moment the Interstate Commerce Commission undertakes not merely to supervise railroad rates and finances and to investigate railroad wrecks, but also to regulate the actual operation of the roads, a new departure begins. The old line between government supervision of railroads and government operation of railroads will be crossed. The present system is a compromise between private ownership and government ownership. If the time has come for the invasion of the operating field by the government, we may as well begin right away to prepare for complete government ownership.

"The McChord report says very correctly: 'The safety problem on this railroad is primarily a question for itself. If governmental interference and action is called for, it results from the inaction of the corporation.' But new legislation extending the commission's power over the operating department of railroads must apply to all railroads alike. Therefore, the question should be considered from the point of view of the railroads of the country as a whole rather than from the viewpoint of a single company. Do the railroads of the United States require this extension of the authority of the Interstate Commerce Commission? One demoralized railroad can be reorganized without necessarily making an important change in governmental policy. Unless it is desirable for all railroads to be more closely regulated, the operation of the New Haven system should certainly be left to the reorganizing talents of the private management now in control.

"Possibly the approach to government ownership of railroads is actually to be by some such process as is now forecast. Yet government ownership is a policy by itself and in itself involving great questions which deserve careful consideration before the policy is fastened upon the nation. It ought not to be embraced in a spasm of popular indignation over the sins of one railroad corporation. Surely direct government administration is no guarantee against 'man failure.' No one needs to search far for 'man failure' in any department of government service—army, navy or post office. What the government commission would do in dealing with the labor unions on the railroads is a nice question which might appropriately be referred to the politicians."

#### Trainmen's Arbitration.

The arbitrators considering the demands of the conductors and trainmen in New York City have heard during the past week the testimony of a number of railroad officers, including John Patterson, trainmaster of the Pittsburgh division of the Pennsylvania; C. F. Ray, trainmaster of the Western division of the New York Central, and E. R. Hewitt, assistant trainmaster of the Bessemer & Lake Erie. The chairman of the board, Seth Low, asked questions indicating that he, and Dr. Finley, the other non-railroader on the board, looked upon the testimony, on both sides, as fragmentary and unsatisfactory; they want evidence which will make clear in their minds the basic merits or demerits of the demands of the employees, and the essential features of the position taken by the railroads. Mr. Sheppard, the arbitrator who represents the employees, complained that the railroads were presenting evidence concerning conditions on the richer roads, which conditions do not properly typify the conditions prevailing in the east generally.

In discussing matters of safety, Mr. Patterson said that automatic couplers and air brakes decreased both the injuries to the men and the amount of their work; and a pushing engine on a freight train not only does not increase the danger, as has been claimed, but it decreases the danger from wrecks due to the pulling out of drawbars.

H. W. Chambers, of the New York Central, gave statistics concerning rates of wages and amounts paid for overtime. J. W. Coneys, of the Vandalia, testified concerning conditions in the western states.

#### A Yellow Government Report.

It scarcely commands public confidence to be informed by the author of this report that because a director happens to be in his opinion a "magician in the art of finance" or a "wizard in the construction, operation and consolidation of great systems," he possesses a "knowledge of the railroad art" in the

sense that he is therefore qualified to be a first class railroad superintendent. Such reasoning would be worthy of a yellow newspaper with an ulterior and sinister purpose of denunciation. This talk, we are frank to say, reaches no further than do the inflammatory yellow newspaper articles to which it is comparable in tone and substance.—*New York Sun*.

#### Railway Club of Pittsburgh.

The Railway Club of Pittsburgh held its first meeting for the fall season on Friday, September 26. The members were taken from Pittsburgh to Wilmerding, Pa., in a special train over the Pennsylvania Railroad, arriving there at 3:30 in the afternoon. They were met at the station by representatives of the Westinghouse Air Brake Company, and were escorted in groups of 25 through the works of that company. Early in the evening a luncheon was served in the Y. M. C. A. classrooms on the third floor of the Welfare building, the Westinghouse orchestra furnishing music for the occasion. At 7:30 the members gathered in the auditorium of the building, where a very interesting program was presented, including an address of welcome by A. L. Humphrey, vice-president and general manager of the company, and an address by A. G. Mitchell, the president of the club. After a number of musical selections, vocal and instrumental, Mr. Humphrey gave a talk, illustrated by moving pictures and stereopticon views, showing the various forms of welfare work which are being promoted at Wilmerding. An important suggestion which he made for the investigation of this subject by the railway club is commented on editorially in this issue. At 9 o'clock, or a little more than five hours after the party entered the plant, a series of moving pictures was thrown on the screen showing the members of the party as they were divided into groups preparatory to going through the plant. About 500 guests were entertained, including members of the railroad club, their wives and friends.

#### MEETINGS AND CONVENTIONS.

*The following list gives names of secretaries, dates of next or regular meetings, and places of meeting.*

- AIR BRAKE ASSOCIATION.**—F. M. Nellis, 53 State St., Boston, Mass. Next convention, May, 1914.
- AMERICAN ASSOCIATION OF DEMURRAGE OFFICERS.**—A. G. Thomason, Boston, Mass. Convention, May 19, 1914, St. Louis.
- AMERICAN ASSOCIATION OF GENERAL PASSENGER AND TICKET AGENTS.**—W. C. Hope, New York. Annual meeting, October 14-15, Philadelphia, Pa.
- AMERICAN ASSOCIATION OF FREIGHT AGENTS.**—R. O. Wells, East St. Louis, Ill. Next convention, April 21, Houston, Tex.
- AMERICAN ASSOCIATION OF RAILROAD SUPERINTENDENTS.**—E. H. Harman, St. Louis, Mo.; 3d Thursday and Friday in May.
- AMERICAN ELECTRIC RAILWAY ASSOCIATION.**—H. C. Donecker, 29 W. 39th St., New York. Next convention, October 13-17, Atlantic City, N. J.
- AMERICAN ELECTRIC RAILWAY MANUFACTURERS' ASSOC.**—H. G. McConaughy, 165 Broadway, New York. Meetings with Am. Elec. Ry. Assoc.
- AMERICAN RAILWAY ASSOCIATION.**—W. F. Allen, 75 Church St., New York. Next meeting, November 19, 1913, Chicago.
- AMERICAN RAILWAY BRIDGE AND BUILDING ASSOCIATION.**—C. A. Lichty, C. & N. W., Chicago. Convention, October 21-24, 1913, Montreal.
- AMERICAN RAILWAY ENGINEERING ASSOCIATION.**—E. H. Fritch, 900 S. Michigan Ave., Chicago. Next convention, March 17-20, Chicago.
- AMERICAN RAILWAY MASTER MECHANICS' ASSOCIATION.**—J. W. Taylor, Old Colony building, Chicago.
- AMERICAN RAILWAY TOOL FOREMEN'S ASSOCIATION.**—A. R. Davis, Central of Georgia, Macon, Ga.
- AMERICAN SOCIETY FOR TESTING MATERIALS.**—Prof. E. Marburg, University of Pennsylvania, Philadelphia, Pa.
- AMERICAN SOCIETY OF CIVIL ENGINEERS.**—C. W. Hunt, 220 W. 57th St., New York; 1st and 3d Wed., except June and August, New York.
- AMERICAN SOCIETY OF ENGINEERING CONTRACTORS.**—J. R. Wenlinger, 11 Broadway, New York; 2d Tuesday of each month, New York.
- AMERICAN SOCIETY OF MECHANICAL ENGINEERS.**—Calvin W. Rice, 29 W. 39th St., New York.
- AMERICAN WOOD PRESERVERS' ASSOCIATION.**—F. J. Angier, B. & O., Baltimore, Md. Next convention, January 20-22, 1914, New Orleans, La.
- ASSOCIATION OF AMERICAN RAILWAY ACCOUNTING OFFICERS.**—C. G. Phillips, 143 Dearborn St., Chicago. Annual meeting, May 28, Atlantic City, N. J.
- ASSOCIATION OF RAILWAY CLAIM AGENTS.**—C. W. Egan, B. & O., Baltimore, Md. Next convention, May, 1914, St. Paul, Minn.
- ASSOCIATION OF RAILWAY ELECTRICAL ENGINEERS.**—Jos. A. Andreucetti, C. & N. W. Ry., Chicago. Annual convention, October 18-24, Chicago.
- ASSOCIATION OF RAILWAY TELEGRAPH SUPERINTENDENTS.**—P. W. Drew, 112 West Adams St., Chicago. Next convention, May 20-23, New Orleans, La.
- ASSOCIATION OF TRANSPORTATION AND CAR ACCOUNTING OFFICERS.**—G. P. Conard, 75 Church St., New York. Next meeting, December 9-10, Galveston, Tex.
- ASSOCIATION OF WATER LINE ACCOUNTING OFFICERS.**—W. R. Evans, Chamber of Commerce, Buffalo, N. Y. Annual meeting, October 8, Philadelphia, Pa.
- BRIDGE AND BUILDING SUPPLY MEN'S ASSOCIATION.**—H. A. Neally, Joseph Dixon Crucible Co., Jersey City, N. J. Meeting with American Railway Bridge and Building Association.
- CANADIAN RAILWAY CLUB.**—James Powell, Grand Trunk Ry., Montreal, Que.; 2d Tuesday in month, except June, July and Aug., Montreal.
- CANADIAN SOCIETY OF CIVIL ENGINEERS.**—Clement H. McLeod, 413 Dorchester St., Montreal, Que.; Thursday, Montreal.
- CAR FOREMEN'S ASSOCIATION OF CHICAGO.**—Aaron Kline, 841 North 50th Court, Chicago; 2d Monday in month, Chicago.
- CENTRAL RAILWAY CLUB.**—H. D. Vought, 95 Liberty St., New York; 2d Thurs. in Jan. and 2d Fri. in March, May, Sept., Nov., Buffalo, N. Y.
- CIVIL ENGINEERS' SOCIETY OF ST. PAUL.**—L. S. Pomeroy, Old State Capitol building, St. Paul, Minn.; 2d Monday, except June, July, August and September, St. Paul.
- ENGINEERS' SOCIETY OF PENNSYLVANIA.**—E. R. Dasher, Box 704, Harrisburg, Pa.; 1st Monday after 2d Saturday, Harrisburg, Pa.
- ENGINEERS' SOCIETY OF WESTERN PENNSYLVANIA.**—E. K. Hiles, Oliver building, Pittsburgh; 1st and 3d Tuesday, Pittsburgh, Pa.
- FREIGHT CLAIM ASSOCIATION.**—Warren P. Taylor, Richmond, Va. Next convention, May 20-22, Galveston, Tex.
- GENERAL SUPERINTENDENTS' ASSOCIATION OF CHICAGO.**—E. S. Koller, 226 W. Adams St., Chicago; Wed. preceding 3d Thurs., Chicago.
- INTERNATIONAL RAILWAY CONGRESS.**—Executive Committee, 11, rue de Louvain, Brussels, Belgium. Convention, 1915, Berlin.
- INTERNATIONAL RAILWAY FUEL ASSOCIATION.**—C. G. Hall, 922 McCormick building, Chicago. Annual convention, May 18-22, Chicago.
- INTERNATIONAL RAILWAY GENERAL FOREMEN'S ASSOCIATION.**—Wm. Hall, 829 West Broadway, Winona, Minn. Next convention, July, Chicago.
- INTERNATIONAL RAILROAD MASTER BLACKSMITHS' ASSOCIATION.**—A. L. Woodworth, Lima, Ohio. Next convention, third Tuesday in August.
- MAINTENANCE OF WAY & MASTER PAINTERS' ASSOCIATION OF THE UNITED STATES AND CANADA.**—W. G. Wilson, Lehigh Valley, Easton, Pa. Next convention, November 18-20, Louisville, Ky.
- MASTER BOILER MAKERS' ASSOCIATION.**—Harry D. Vought, 95 Liberty St., New York.
- MASTER CAR BUILDERS' ASSOCIATION.**—J. W. Taylor, Old Colony building, Chicago.
- MASTER CAR AND LOCOMOTIVE PAINTERS' ASSOC. OF U. S. AND CANADA.**—A. P. Danc, B. & M., Reading, Mass.
- NATIONAL RAILWAY APPLIANCE ASSOC.**—Bruce V. Crandall, 537 So. Dearborn St., Chicago. Meetings with Am. Ry. Eng. Assoc.
- NEW ENGLAND RAILROAD CLUB.**—W. E. Cade, Jr., 683 Atlantic Ave., Boston, Mass.; 2d Tuesday in month, except June, July, Aug. and Sept., Boston.
- NEW YORK RAILROAD CLUB.**—H. D. Vought, 95 Liberty St., New York; 3rd Friday in month, except June, July and August, New York.
- NORTHERN RAILROAD CLUB.**—C. L. Kennedy, C., M. & St. P., Duluth, Minn.; 4th Saturday, Duluth.
- PEORIA ASSOCIATION OF RAILROAD OFFICERS.**—M. W. Rotchford, Union Station, Peoria; 2d Thursday.
- RAILROAD CLUB OF KANSAS CITY.**—C. Manlove, 1008 Walnut St., Kansas City, Mo.; 3d Friday in month, Kansas City.
- RAILWAY BUSINESS ASSOCIATION.**—Frank W. Noxon, 2 Rector St., New York. Annual dinner, second week in December, 1913, New York.
- RAILWAY CLUB OF PITTSBURGH.**—J. B. Anderson, Penna. R. R., Pittsburgh, Pa.; 4th Friday in month, except June, July and August, Pittsburgh.
- RAILWAY ELECTRICAL SUPPLY MANUFACTURERS' ASSOC.**—J. Scribner, 1021 Monadnock Block, Chicago. Meetings with Assoc. Ry. Elec. Engrs.
- RAILWAY FIRE PROTECTION ASSOCIATION.**—C. B. Edwards, Mobile & Ohio, Mobile, Ala. Next meeting, October 7, Chicago.
- RAILWAY GARDENING ASSOCIATION.**—J. S. Butterfield, Lee's Summit, Mo.
- RAILWAY DEVELOPMENT ASSOCIATION.**—W. Nicholson, Kansas City Southern, Kansas City, Mo.
- RAILWAY SIGNAL ASSOCIATION.**—C. C. Rosenberg, Bethlehem, Pa. Convention, October 14, Nashville, Tenn.
- RAILWAY STOREKEEPERS' ASSOCIATION.**—J. P. Murphy, Box C, Collinwood, Ohio.
- RAILWAY SUPPLY MANUFACTURERS' ASSOC.**—J. D. Conway, 2135 Oliver bldg., Pittsburgh, Pa. Meetings with M. M. and M. C. B. Assocs.
- RAILWAY TEL. & TEL. APPLIANCE ASSOC.**—W. E. Harkness, 284 Pearl St., New York. Meetings with Assoc. of Ry. Teleg. Svs.
- RICHMOND RAILROAD CLUB.**—F. O. Robinson, Richmond, Va.; 2d Monday except June, July and August.
- ROADMASTERS' AND MAINTENANCE OF WAY ASSOCIATION.**—L. C. Ryan, C. & N. W., Sterling, Ill. Next convention, September 8-11, 1914, Chicago.
- ST. LOUIS RAILWAY CLUB.**—B. W. Frauenthal, Union Station, St. Louis, Mo.; 2d Friday in month, except June, July and Aug., St. Louis.
- SIGNAL APPLIANCE ASSOCIATION.**—F. W. Edmonds, 3868 Park Ave., New York. Meeting with annual convention Railway Signal Association.
- SOCIETY OF RAILWAY FINANCIAL OFFICERS.**—C. Nyquist, La Salle St. Station, Chicago.
- SOUTHERN ASSOCIATION OF CAR SERVICE OFFICERS.**—E. W. Sandwich, A. & W. P. Ry., Montgomery, Ala. Annual meeting, October 16, 1913, Atlanta, Ga.
- SOUTHERN & SOUTHWESTERN RAILWAY CLUB.**—A. J. Merrill, Grant bldg., Atlanta, Ga.; 3d Thurs., Jan., March, May, July, Sept., Nov., Atlanta.
- TOLEDO TRANSPORTATION CLUB.**—J. G. Macomber, Woolson Spice Co., Toledo, Ohio; 1st Saturday, Toledo.
- TRACK SUPPLY ASSOCIATION.**—W. C. Kidd, Ramapo Iron Works, Hillsburn, N. Y. Meeting with Roadmasters' and Maintenance of Way Association.
- TRAFFIC CLUB OF CHICAGO.**—W. H. Wharton, La Salle Hotel, Chicago.
- TRAFFIC CLUB OF NEW YORK.**—C. A. Swope, 290 Broadway, New York; last Tuesday in month, except June, July and August, New York.
- TRAFFIC CLUB OF PITTSBURGH.**—D. L. Wells, Erie, Pittsburgh, Pa.; meetings monthly Pittsburgh.
- TRAFFIC CLUB OF ST. LOUIS.**—A. F. Versen, Mercantile Library building, St. Louis, Mo. Annual meeting in November. Noonday meetings October to May.
- TRAIN DESPATCHERS' ASSOCIATION OF AMERICA.**—J. F. Mackie, 7122 Stewart Ave., Chicago. Next convention, June 16, Jacksonville, Fla.
- TRANSPORTATION CLUB OF BUFFALO.**—J. M. Sells, Buffalo; first Saturday after first Wednesday.
- TRANSPORTATION CLUB OF DETROIT.**—W. R. Hurley, L. S. & M. S., Detroit, Mich.; meetings monthly.
- TRAVELING ENGINEERS' ASSOCIATION.**—W. O. Thompson, N. Y. C. & H. R., East Buffalo, N. Y. Next meeting, Chicago.
- UTAH SOCIETY OF ENGINEERS.**—Fred D. Ulmer, Oregon Short Line, Salt Lake City, Utah; 3rd Friday of each month, except July and August.
- WESTERN CANADA RAILWAY CLUB.**—W. H. Rosevear, P. O. Box 1707, Winnipeg, Man.; 2d Monday, except June, July and August, Winnipeg.
- WESTERN RAILWAY CLUB.**—J. W. Taylor, Old Colony building, Chicago; 3d Tuesday of each month, except June, July and August.
- WESTERN SOCIETY OF ENGINEERS.**—J. H. Warder, 1735 Monadnock Block, Chicago; 1st Monday in month, except July and August, Chicago.

# Traffic News.

According to a report compiled by the Oregon Railroad Commission out of 26,963 trips of passenger trains in the state from January to June inclusive this year, 21,356 were on time, or 79.2 per cent. The average delay of the trains late was 11.6 minutes.

The Pullman Company announces that, beginning November 1, the rate for a lower berth in a sleeping car between Los Angeles and San Diego will be reduced from \$2 to \$1.50. This change was made on the informal request of the California State Railroad Commission.

At a recent meeting of the Southwestern Tariff Committee it was decided to make effective on October 1 the plan announced earlier in the year by which tariffs issued by the committee will

be furnished to shippers at a subscription price for the year based on the extra cost of paper, presswork and mailing above the cost of the supply required for the railways' own use. The prices were stated in a special circular issued June 16.

### Car Surpluses and Shortages.

Arthur Hale, chairman of the committee on relations between railroads of the American Railway Association, in presenting statistical bulletin No. 151-A, giving a summary of car surpluses and shortages by groups from June 6, 1912, to September 15, 1913, says: The total surplus on September 15, 1913, was 61,753 cars; on September 1, 1913, 72,576 cars; and on September 12, 1912, 27,380 cars. Compared with the preceding period; there is a decrease in the total surplus of 11,823 cars, made up as follows: A decrease of 10,594 in box, 1,413 in flat, and an increase of 25 in coal and 159 in miscellaneous car surplus.

CAR SURPLUSES AND SHORTAGES.

Date	No. of roads.	Surpluses				Shortages					
		Box.	Flat.	Coal, gondola and hopper.	Other kinds.	Total.	Box.	Flat.	Coal, gondola and hopper.	Other kinds.	Total.
Group *1—September 15, 1913.....	7	168	140	32	209	549	83	115	17	3	218
" 2—" " 15, 1913.....	31	366	53	1,499	530	2,448	740	0	812	0	1,552
" 3—" " 15, 1913.....	30	332	283	327	661	1,603	2,134	25	1,801	344	4,304
" 4—" " 15, 1913.....	14	2,433	380	633	506	3,952	2,712	363	3,186	560	6,821
" 5—" " 15, 1913.....	26	0	0	929	505	1,434	1,953	616	749	36	3,354
" 6—" " 15, 1913.....	34	6,292	303	1,162	3,489	11,246	1,523	132	1,087	104	2,846
" 7—" " 15, 1913.....	4	56	18	544	309	927	163	0	0	32	195
" 8—" " 15, 1913.....	20	4,808	198	1,661	2,552	9,219	289	6	51	1	347
" 9—" " 15, 1913.....	15	1,985	238	431	604	3,258	106	0	0	4	110
" 10—" " 15, 1913.....	21	3,738	834	1,420	7,098	13,090	439	27	28	178	672
" 11—" " 15, 1913.....	6	12,220	288	76	1,443	14,027	930	139	0	106	1,175
Total .....	208	32,398	2,735	8,714	17,906	61,753	11,072	1,423	7,731	1,368	21,594

\*Group 1 is composed of New England lines; Group 2—New York, New Jersey, Delaware, Maryland and Eastern Pennsylvania lines; Group 3—Ohio, Indiana, Michigan and Western Pennsylvania lines; Group 4—West Virginia, Virginia, North and South Carolina lines; Group 5—Kentucky, Tennessee, Mississippi, Alabama, Georgia and Florida lines; Group 6—Iowa, Illinois, Wisconsin and Minnesota lines; Group 7—Montana, Wyoming, Nebraska, North Dakota and South Dakota lines; Group 8—Kansas, Colorado, Missouri, Arkansas and Oklahoma lines; Group 9—Texas, Louisiana and New Mexico lines; Group 10—Washington, Oregon, Idaho, California, Nevada and Arizona lines; Group 11—Canadian lines.

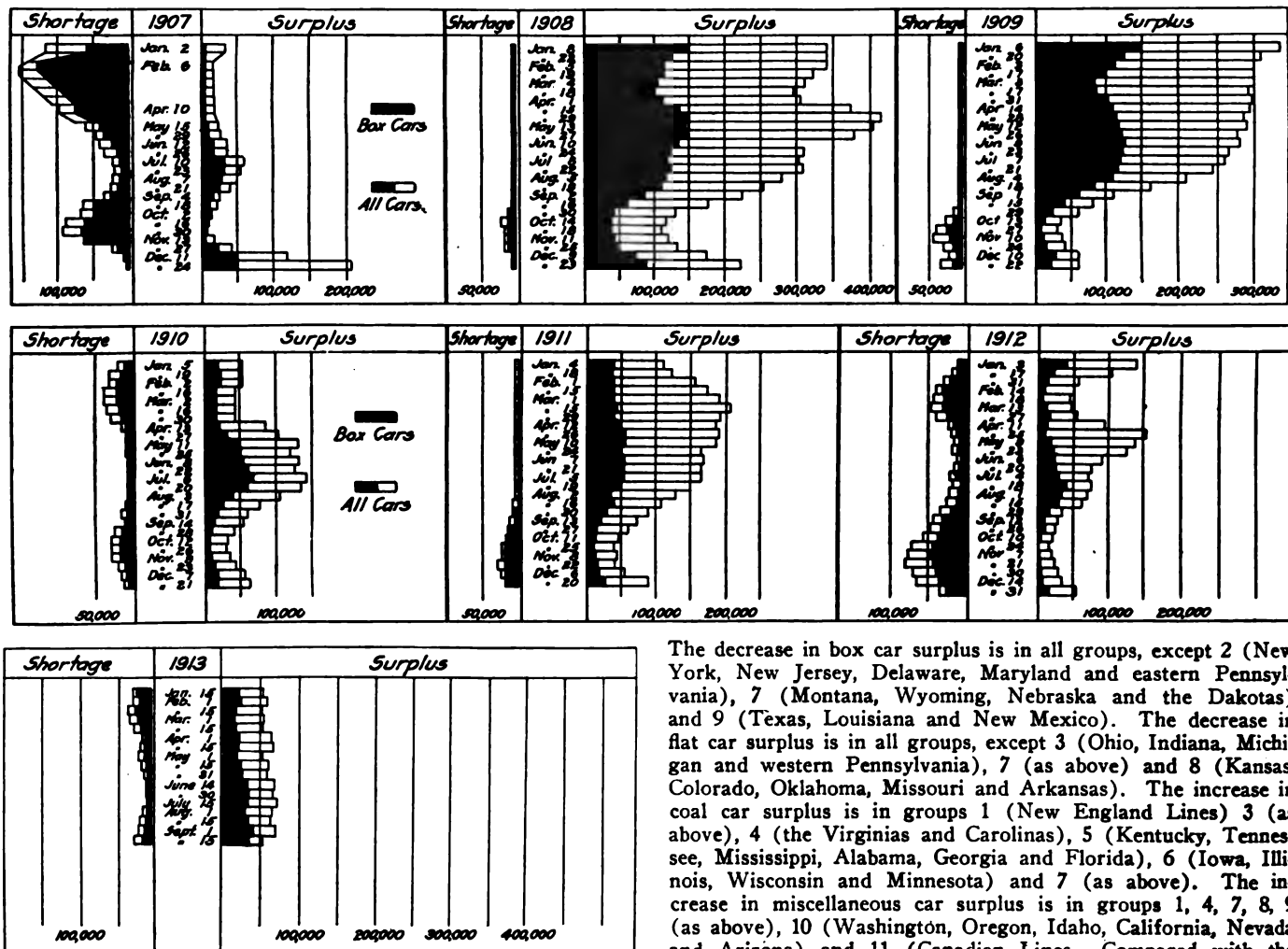

Car Surpluses and Shortages, 1907 to 1913.

The decrease in box car surplus is in all groups, except 2 (New York, New Jersey, Delaware, Maryland and eastern Pennsylvania), 7 (Montana, Wyoming, Nebraska and the Dakotas) and 9 (Texas, Louisiana and New Mexico). The decrease in flat car surplus is in all groups, except 3 (Ohio, Indiana, Michigan and western Pennsylvania), 7 (as above) and 8 (Kansas, Colorado, Oklahoma, Missouri and Arkansas). The increase in coal car surplus is in groups 1 (New England Lines) 3 (as above), 4 (the Virginias and Carolinas), 5 (Kentucky, Tennessee, Mississippi, Alabama, Georgia and Florida), 6 (Iowa, Illinois, Wisconsin and Minnesota) and 7 (as above). The increase in miscellaneous car surplus is in groups 1, 4, 7, 8, 9 (as above), 10 (Washington, Oregon, Idaho, California, Nevada and Arizona) and 11 (Canadian Lines). Compared with the preceding period; there is an increase in the total shortage of

6,324 cars, of which 3,445 is in box, 2,522 in coal, 700 in miscellaneous, and a decrease of 343 in flat car shortage. The increase in box car shortage is in all groups, except 1, 6, 10 and 11 (as above). The increase in coal car shortage is in groups 2, 3, 4 and 6 (as above). The increase in miscellaneous car shortage is in all groups, except 1, 8 and 9 (as above). The decrease in flat car shortage is in groups 2, 3, 4, 6, 8, 10 and 11.

Compared with the same date of 1912; there is an increase in the total surplus of 34,373 cars, of which 24,492 is in box, 1,450 in flat, 3,404 in coal and 5,027 in miscellaneous car surplus. There is a decrease in the total shortage of 14,406 cars, of which 11,765 is in box, 1,759 in flat, 600 in coal and 282 in miscellaneous car shortage.

The accompanying table gives car surplus and shortage figures by groups for the last period covered in the report and the diagram shows total bi-weekly surpluses and shortages from 1907 to 1913.

#### Pasquotank Objects.

The Governor and other officers of the State of North Carolina are negotiating with the railroads with a view to securing changes in freight rates, some of which changes may not be extreme reductions. The Governor may possibly compromise some points. This possibility produces a chill in some quarters. From Elizabeth City it is reported that the Pasquotank County Just Freight Rate Association, at a largely attended meeting, has enthusiastically declared its opposition to the proposition by the railroads to effect a compromise. It was ordered that the secretary of the association telegraph President Tate of the State Freight Rate Association and Governor Craig, of this action. A committee was appointed to solicit subscriptions from the merchants to defray the expenses of delegates to be sent to Raleigh.

#### Extensive Rate Reduction in North Carolina.

The legislature of North Carolina is now sitting in special session, at Raleigh, to consider proposals made by the railroads for readjustment of freight rates, both intrastate and interstate, the business men of important cities having demanded reductions from eastern, northern and western states. The propositions of the railroads are the result of extended discussions with the governor and other state officers; and the governor has recommended that the tariffs now proposed by the roads be accepted. These tariffs make changes which will reduce the railroads' income at the rate of \$2,000,000 a year.

#### The Two-Dollar Controversy at St. Louis.

Shippers and receivers of carload freight handled by the Manufacturers' Railway Company have been notified that hereafter they must make a \$2 payment in addition to the regular St. Louis rates. This announcement was made by George F. Moore, president of the road.

Mr. Moore says that this action is rendered necessary by the action of the proprietary and tenant lines of the Terminal Association in canceling the participation in rates heretofore enjoyed by the Manufacturers' Railway.

Should the Interstate Commerce Commission grant a rehearing and reverse the latest ruling, the \$2 payments made in the meantime will be refunded, unless the commission forbids, says President Moore.

"Freight in less than carload lots cannot be handled by the Manufacturers for any other than these lines: Rock Island, Chicago & Eastern Illinois, Chicago & Alton, Frisco, M. K. & T., and Toledo, St. Louis & Western.

"These companies having joint facility contracts," says the announcement, "the Manufacturers' Railway Company still will receive for their traffic at the freight station at Second and Rutger streets."

The circular further states that the Manufacturers' through its counsel, and the shippers, represented by counsel, will ask a rehearing of the case, which was "partially decided" by the commission.

Soon after the decision of the commission in August, President Moore addressed a letter to all trunk lines entering St. Louis, inviting them to take over the operation of the Manufacturers' line on a cost basis for one year. Some of the railroad executives viewed the plan with favor, but charges were made

that it was a plan to give the Terminal road control of the rival property, and Mr. Moore soon withdrew the offer. He has stated repeatedly that his line cannot be operated on a charge of only \$2 a car.

The Busch interests have bought the St. Louis & O'Fallon road and have acquired a trackage right over the Alton & Southern, thus obtaining a line, by means of a transfer boat, to the St. Louis & O'Fallon coal mines. By taking over this traffic, which the Terminal has controlled, the Busch people expect to prove independence of the Terminal. The St. Louis & O'Fallon, which is nine miles long, has been connected with the outer belt of the Terminal. It parallels the Louisville & Nashville and intersects an uncompleted line of the Alton & Southern.

#### STATE COMMISSIONS.

Henry B. Schreiber, a member of the Louisiana Railroad Commission, died at New Orleans, La., on September 22.

C. S. Cunningham, who was formerly and until December, 1912, an assistant superintendent on the Grand Trunk, has been appointed a member of the Michigan Railroad Commission, to succeed James Scully, deceased.

The Iowa Railroad Commission will hold an adjourned hearing on October 14, at Des Moines, on the subject of demurrage in Iowa. Among the subjects to be considered is a proposed increase of the demurrage rate of from \$1 to \$3.

The Nebraska Railroad Commission has issued an order declaring the present rates on apples in the state unreasonable and prescribing a maximum distance table of rates up to 600 miles, ranging from 5 cents to 30.75 cents per 100 lbs., graded for each increase of five miles in the length of haul.

Henderson Martin, chairman of the Kansas Public Utilities Commission, has sent notices to the utilities commissions of Iowa, Minnesota, Nebraska, Oklahoma, Missouri, North Dakota and South Dakota, asking them to join in a movement intended to prevent a proposed increase in railroad freight rates on manufactured products shipped from Eastern states to the middle west. He said the railroads recently announced an increase of 5 per cent. in the rates on all business originating between New York and Chicago, and that 75 per cent. of the incoming freight to the eight states, which he declared should oppose the proposed increase, originates in the territory east of Chicago. Chairman Martin suggested that the various state commissions should meet and outline a plan of action before appearing at a hearing before the Interstate Commerce Commission.

#### COURT NEWS.

The attorney-general of Wisconsin has recently asked the Supreme Court of the state for permission to file an information in quo warranto to determine whether the charter of the Northern Pacific should not be forfeited on the ground that the company did not pay the fee required by the Wisconsin laws for increasing its capital stock. He says the amount due is \$250,000. The question is to be argued this month.

**PROPOSED ARGENTINE PENSION FUND.**—The bill recently passed by the Argentine chamber of deputies, and modified by the Legislative committee, for establishing a national pension fund, may go through the senate in the form in which it now stands. In the main the bill includes in its benefits all the employees of the state lines and those of private companies under national jurisdiction, and service will be computed in calculating the period, though they may at any time have been subjected to provincial jurisdiction. Article 5 provides that the fund shall be formed by contributions from the state, from the private railways and from the employees, and the money collected from: (1) A tax on railway fares created by the law which consists of ten cents on tickets above one dollar, and four cents on the price of each season ticket. (2) Sums received for excess charges. (3) Deduction of 5 per cent. from the salaries and wages of employees. (4) Retention by twenty-four monthly instalments of one-half of the first monthly salary, and the whole for one month only of every increase in salary.

REVENUES AND EXPENSES OF RAILWAYS.

MONTH OF JULY, 1913.

Name of road.	Average mileage operated during period.	Operating revenues				Operating expenses				Net operating revenue (or deficit).	Outside operations, net.	Taxes.	Operating income (or loss).	Increase (or decrease) comp. with last year.
		Freight.	Passenger.	Inc. misc.	Total.	Way and structures.	Maintenance of equipment.	Traffic.	Trans- portation.					
Alabama & Vicksburg.....	309	\$276,295	\$120,187	\$432,289	\$54,184	\$111,025	\$13,095	\$149,011	\$8,908	\$336,223	-\$376	\$15,300	\$80,390	-\$2,723
Alabama Great Southern.....	143	90,255	44,814	146,297	24,190	32,025	3,851	54,509	5,818	24,393	-1,467	7,450	19,632	-19,632
Atlantic City.....	167	73,499	285,869	372,813	23,833	11,614	3,737	158,831	3,450	201,505	-5,533	9,000	156,755	-23,973
Bangor & Aroostook.....	631	141,492	58,009	214,474	42,388	43,195	2,657	78,870	10,617	177,727	128	9,757	27,118	-22,142
Canadian Pacific Lines in Maint.....	233	39,620	26,284	72,957	45,793	15,357	6,766	33,860	5,247	107,023	-34,066	11,000	-45,066	-13,741
Chicago & Erie.....	270	336,942	66,938	442,941	88,857	104,669	23,902	220,927	12,379	450,734	-7,793	12,895	-20,676	-54,119
Chicago & North Western.....	7,976	4,670,398	2,004,596	7,345,766	1,337,481	1,053,055	129,214	2,682,740	141,443	5,343,933	-4,597	320,000	1,677,236	-108,299
Chicago, Rock Island & Pacific.....	7,525	3,488,658	1,717,420	5,559,682	941,005	905,105	160,307	2,226,534	155,062	4,388,013	-19,576	270,753	881,346	-368,261
Cincinnati, New Orleans & Texas Pacific.....	337	609,346	163,851	820,468	91,355	192,178	24,620	246,517	18,826	573,496	-146	29,000	217,826	-12,529
Colorado Midland.....	338	121,810	39,959	171,210	36,924	37,262	8,882	67,549	5,554	156,171	-148	8,000	6,891	-13,668
Cumberland Valley.....	162	212,289	64,147	287,202	63,961	24,916	4,840	88,198	7,670	189,585	97,617	5,702	92,154	13,975
Denver & Salt Lake.....	215	61,377	61,759	129,598	27,017	18,333	4,439	32,163	4,008	85,960	48,797	4,000	39,638	5,071
Duluth, Winnipeg & Pacific.....	166	134,179	26,845	163,216	39,227	17,899	3,079	48,662	5,552	114,419	48,797	8,172	40,625	24,811
Erie.....	1,988	3,386,386	1,007,225	4,762,590	620,149	824,510	105,918	1,484,496	124,243	3,159,316	1,603,274	138,546	1,465,119	-79,705
Florida East Coast.....	642	141,193	107,306	287,153	82,093	63,504	5,024	132,982	11,248	294,851	-1,407	20,000	-29,105	-14,166
Gulf & Ship Island.....	308	126,788	43,376	181,493	20,677	25,912	2,249	45,394	7,878	102,110	79,383	7,156	72,227	21,139
Illinois Central.....	4,763	3,443,049	1,191,204	5,318,442	869,549	1,191,055	99,013	1,985,742	136,637	4,281,996	1,036,446	264,000	768,480	153,715
Kansas City Southern.....	827	580,474	154,650	813,883	71,491	115,219	27,456	280,917	35,077	530,160	283,720	40,013	243,710	3,393
Lehigh & Hudson River.....	97	134,327	4,822	149,581	38,857	20,073	1,451	55,861	3,599	119,861	29,740	4,000	25,740	-17,893
Lehigh & New England.....	269	131,974	839	137,246	22,154	21,502	1,457	35,932	3,195	84,240	53,006	3,179	49,827	-10,126
Lehigh Valley.....	1,438	2,806,549	519,096	3,447,701	413,137	582,355	93,321	1,159,394	67,304	2,315,511	-23,583	121,000	987,607	-266,263
Louisiana Ky. & Navigation.....	351	115,898	27,440	152,496	32,820	22,687	6,504	61,819	5,641	129,471	23,025	5,500	17,552	-31,582
Missouri & North Arkansas.....	365	64,812	39,616	110,400	27,184	17,382	3,031	40,350	5,460	93,407	16,993	5,500	11,493	20,502
Monganaela.....	67	129,131	3,173	134,563	21,168	6,081	3,02	25,106	2,180	54,837	79,726	2,350	77,376	21,494
Morgan's Louisiana Railroad & S. S. Co.....	404	208,575	101,558	332,433	43,905	84,686	12,879	143,276	14,071	298,817	33,616	18,250	14,109	-14,216
New Orleans & North Eastern.....	196	273,137	57,873	355,339	37,408	74,358	9,634	132,040	12,501	265,941	89,398	15,800	74,387	31,196
New York Central & Hudson River.....	3,750	5,579,457	1,019,811	7,345,766	1,616,209	1,920,245	210,643	3,558,766	254,741	7,360,604	2,544,207	535,284	1,973,918	-136,689
New York, Ontario & Western.....	566	600,324	330,125	987,904	138,067	134,700	12,367	309,614	20,231	614,979	37,925	19,000	356,815	-61,329
New York, Susquehanna & Western.....	154	144,594	53,912	228,379	32,613	30,851	1,690	95,958	6,763	167,875	56,504	17,649	42,922	-109
Norfolk Southern.....	569	148,076	78,247	255,972	29,802	33,581	4,528	86,122	12,564	166,597	89,375	9,210	80,165	376
Ortson-Washington R. R. & Nav. Co.....	1,914	927,974	497,533	1,525,539	235,178	170,800	58,341	496,477	55,135	1,015,931	509,608	112,968	390,596	-128,459
Philadelphia & Reading.....	1,020	2,978,517	681,287	3,856,889	445,801	631,583	49,075	1,289,075	69,749	2,485,383	1,371,506	103,050	1,294,516	-99,131
Port Reading.....	21	89,613	35,273	145,684	14,174	225	2,624	26,095	279	11,406	51,278	8,000	40,553	-18,480
St. Louis, San Francisco & Texas.....	244	101,518	113,136	395,928	111,141	93,567	12,436	158,593	21,110	87,911	3,281	17,800	54,228	-38,333
St. Louis Southwestern of Texas.....	811	236,950	69,721	24,553	18,705	6,421	1,971	26,961	3,622	37,680	40,153	3,021	37,132	-2,730
San Antonio & Aransas Pass.....	724	228,745	138,205	388,623	83,020	69,774	5,623	160,606	11,166	330,189	58,434	12,000	46,434	-23,887
San Pedro, Los Angeles & Salt Lake.....	1,133	518,261	285,549	865,526	119,228	336,336	32,682	289,193	20,329	597,768	262,758	43,000	251,961	-32,027
Seaboard.....	3,082	1,150,745	421,916	1,812,213	223,133	255,464	66,087	702,011	53,703	1,301,378	510,835	82,000	426,963	63,263
Southern Pacific Co.....	6,381	4,478,638	2,941,255	8,029,287	911,519	1,123,852	162,842	2,191,254	240,945	4,630,412	3,398,875	401,348	3,134,003	-499,016
Spokane International.....	163	69,721	24,553	97,833	18,705	6,421	1,971	26,961	3,622	37,680	40,153	3,021	37,132	-2,730
Spokane, Portland & Seattle.....	556	245,532	185,841	467,475	66,241	37,792	8,704	107,584	12,845	233,166	234,187	53,400	182,820	-15,682
Trinity & Braes Valley.....	463	102,876	54,380	164,176	49,781	31,311	10,643	91,881	11,747	195,363	-31,189	4,000	184,991	-14,803
Union Railroad of Pennsylvania.....	31	82,156	52,146	144,852	22,985	29,119	3,728	53,326	4,934	114,092	30,760	7,800	22,820	-21,852
Vicksburg, Shreveport & Pacific.....	171	82,156	52,146	144,852	22,985	29,119	3,728	53,326	4,934	114,092	30,760	7,800	22,820	-21,852
Virginian.....	503	420,724	36,457	471,172	60,993	86,619	5,491	111,544	9,241	273,888	197,288	21,060	182,511	49,969
Western Pacific.....	934	441,121	149,014	605,172	110,768	55,389	27,074	191,402	39,878	425,511	180,661	29,667	151,772	27,827
Wheeling & Lake Erie.....	459	675,127	63,870	775,447	187,760	148,402	8,830	238,302	16,026	599,320	176,127	32,339	143,528	-63,551
Yazoo & Mississippi Valley.....	1,372	548,613	202,541	807,249	172,166	156,149	14,289	355,340	26,647	724,591	82,658	43,000	38,661	-47,737

## Railway Officers.

### Executive, Financial and Legal Officers.

W. L. Seddon, assistant to president of the Seaboard Air Line, at Norfolk, Va., has been elected also vice-president of the Macon, Dublin & Savannah.

T. H. Burgess, assistant commerce counsel of the Erie at New York, has been appointed assistant general solicitor of the Erie, the New York, Susquehanna & Western, the New Jersey & New York, and the Chicago & Erie, with headquarters at New York.

J. W. McCullough, auditor of the New Orleans, Texas & Mexico, Beaumont, Sour Lake & Western and Orange & Northwestern, has been appointed treasurer also of the two former roads, with headquarters at New Orleans, La., succeeding J. H. Lauderdale, transferred.

William Curren Everett, who has been appointed auditor of the Virginian Railway, with headquarters at Norfolk, Va., as has been announced in these columns, was born on September 3, 1879, at Fort Valley, Ga., and was educated in the high schools. He began railway work in 1896, with the Georgia & Alabama, and from August 1, 1900, to December, 1902, was in the service of its successor, the Seaboard Air Line, at Portsmouth, Va. He was then appointed store accountant of the Cincinnati Traction Company, at Cincinnati, Ohio, and in August, 1903, returned to the Seaboard Air Line, at Portsmouth, leaving that road in January, 1906, to go to the Virginian Railway, and September 18, was promoted to auditor as above noted.

### Operating Officers.

C. H. Calkins has been appointed chief trainmaster of the Buffalo division of the New York Central & Hudson River, with office at Buffalo, N. Y.

E. P. Welshonce has been appointed trainmaster of the west end, Cumberland division of the Baltimore & Ohio, with office at Keyser, W. Va., succeeding M. H. Broughton, promoted.

N. A. Waldron, storekeeper of the St. Louis Southwestern, with headquarters at Pine Bluff, Ark., has been appointed superintendent of the Missouri, Kansas & Texas, with office at Parsons, Kan.

C. Woodard has been appointed assistant superintendent of the Texas & New Orleans and the Galveston, Harrisburg & San Antonio, Galveston division, with office at Houston, Tex., succeeding F. J. Taylor, assigned to other duties.

Thomas K. Scott has resigned as general manager of the Georgia Railroad, on account of ill health, effective October 1, but will continue his connection with the road until July 1, 1914, and C. A. Wickersham, president and general manager of the Atlanta & West Point and the Western Railway of Alabama, at Atlanta, Ga., has been appointed, also general manager of the Georgia Railroad, with headquarters at Augusta.

Charles H. Motsett, whose appointment as superintendent of the new New York division of the New York, New Haven & Hartford, with headquarters at Harlem River, N. Y., has been announced in these columns, was born on December 4, 1875, at Peoria, Ill., and was educated in the public schools of his native town. He began railway work as a clerk with the Great Eastern Fast Freight Line at Peoria in March, 1891, and one year later went to the Chicago, Rock Island & Pacific, serving as yard clerk and switchman alternately, until September, 1902, when he was transferred to Rock Island, Ill., as assistant night yardmaster, and on April 1, 1903, was promoted to assistant general yardmaster in the city terminal. The following October he was transferred to Council Bluffs, Iowa, and in October, 1904, was again transferred to Des Moines, in the same capacity. He was appointed trainmaster in October, 1905, of the Minneapolis & St. Louis, at Des Moines, and in February, 1908, went to the New York, New Haven & Hartford as freight trainmaster on the New York division, and in December, 1909, when that division was abolished, he was appointed trainmaster of terminals at Harlem River, which position he held at the time of his appointment as superintendent of the re-established New York division of the same road, as above noted.

### Traffic Officers.

H. R. Wilson has been appointed commercial agent of the New Orleans Great Northern, at Jackson, Miss., in place of J. J. Stevens, resigned.

J. A. Fitzgerald has been appointed soliciting freight agent of the Atchison, Topeka & Santa Fe, at Houston, Tex., in place of W. R. Pillsbury, resigned.

W. R. Pillsbury has been appointed traveling freight and passenger agent of the Chicago, Burlington & Quincy, with headquarters at Dallas, Tex., succeeding Charles Sorg, Jr., resigned.

Charles Sorg, Jr., traveling freight and passenger agent of the Chicago, Burlington & Quincy, at Dallas, Tex., has been appointed commercial agent of the Ft. Worth & Denver City, at Ft. Worth, Tex.

P. W. Booth has been appointed traveling freight agent of the International & Great Northern, with headquarters at San Antonio, Tex., succeeding E. H. McFadden, who has been transferred to Houston, Tex.

G. S. Hinkins, freight soliciting agent of the Southern at Huntsville, Ala., has been appointed commercial agent, with office at Savannah, Ga., succeeding C. E. Gay, Jr., resigned to accept service with another company.

J. E. Shipley has been appointed assistant general passenger agent of the Tennessee Central, with headquarters at Nashville, Tenn., and J. F. Jenkins having resigned as city passenger agent at Nashville, to engage in other business, his former position has been abolished.

### Engineering and Rolling Stock Officers.

W. W. Morrison has been appointed engineer maintenance of way and structures of the Pittsburg & Shawmut, with headquarters at Kittanning, Pa.

George C. Cleveland, chief engineer of the Lake Shore & Michigan Southern, at Cleveland, Ohio, has been appointed also chief engineer of the Cleveland Short Line, succeeding Samuel Rockwell.

R. D. Garner has been appointed engineer of construction of the Southern New England Railroad Corporation, and the Southern New England Railway Company, with office at Providence, R. I., effective October 1.

S. H. Osborne has been appointed division engineer of the Oregon Short Line, covering the territory Pocatello to Granger, including branches, with headquarters at Pocatello, Idaho. G. H. Cumberland, assistant engineer at Salt Lake City, Utah, has been appointed division engineer, with headquarters at Pocatello, with jurisdiction over the territory, Pocatello yard and Pocatello to Huntington, including branches. Mr. Osborne and Mr. Cumberland succeed A. Q. Campbell, assistant superintendent, resigned.

Harry Rose Warnock, whose appointment as superintendent of motive power of the Western Maryland, with headquarters at Hagerstown, Md., has been announced in these columns, was born on July 16, 1870, at Newcastle, Pa., and was educated in the public schools. He began railway work in June, 1889, with the Pennsylvania Lines West of Pittsburgh as a freight brakeman, and later in the same year went to the Pittsburgh & Lake Erie as a brakeman. He was then locomotive fireman and later engine man on the same road. From May, 1901, to May, 1904, he was consecutively engine despatcher, roundhouse and general foreman on the Monongahela division of the same road, and then to October, 1905, was master mechanic of the West Side Belt, at Pittsburgh, Pa. In October, 1905, he became general foreman of the Monongahela Railroad and was subsequently made master mechanic of that road, which position he held at the time of his recent appointment as superintendent of motive power of the Western Maryland, as above noted.

### Purchasing Officers.

J. M. Killian has been appointed storekeeper of the St. Louis Southwestern lines, and will have charge of all miscellaneous supplies and material other than ties, timber, piling, lumber and fuel, with headquarters for the St. Louis Southwestern at Pine Bluff, Ark., and for the St. Louis Southwestern of Texas at Tyler, Tex. He succeeds N. A. Waldron, resigned.

**Special Officers.**

Donald C. Welty, assistant agricultural agent of the Texas & Pacific at New Orleans, La., has been appointed agricultural commissioner of the St. Louis, Iron Mountain & Southern, with headquarters at St. Louis, Mo., succeeding L. A. Markham, resigned on account of ill health; effective October 1.

**OBITUARY.**

James Smith, formerly, from July, 1884, to July, 1887, traffic manager of the Wabash Western (now the Wabash), and later successively chairman of the Transcontinental Association and the Trans-Missouri Association until 1893, died recently at his home in Ft. Wayne, Ind., aged 77 years.

William F. Ray, general superintendent of the Boston & Maine, died suddenly on September 26, at Boston, Mass. He was born in 1857 at South Vernon, Vt., and was educated at Fort Wayne and at the University of Notre Dame, South Bend, Ind. He began railway work in 1874 as locomotive fireman on the Connecticut River Railroad, now a part of the Boston & Maine, and later held various positions in the freight train service, including that of brakeman and conductor, and then entered the passenger train service as conductor. He was subsequently trainmaster and assistant superintendent. In 1903 he was appointed superintendent of the Concord division of the Boston & Maine, and in October, 1911, was transferred as superintendent to the Portland division. He was appointed general superintendent in October, 1912.

Samuel B. Haupt, president and general manager of the Susquehanna, Bloomsburg & Berwick, died at his home at Milton, Pa., on September 28, at the age of 64. His death was due to injuries he sustained in a collision on his own road at Berwick four weeks ago. He was born in Union county, Pennsylvania, and began railway work on August 10, 1868, as an apprentice in the Pennsylvania Railroad shops at Altoona, and later became machinist. He subsequently was draftsman, chief draftsman and assistant master mechanic of the same shops. He was then superintendent of the Roanoke Machine Works, and from May, 1885, to May, 1891, was also superintendent of motive power of the Norfolk & Western. He later became general manager of the Central Pennsylvania & Western, and since January 1, 1912, had been president and general manager of its successor, the Susquehanna, Bloomsburg & Berwick.

John F. Ensign, chief inspector of locomotive boilers, in the Division of Locomotive Boiler Inspection, of the Interstate Commerce Commission, died on September 24, after a long illness, at his home in Washington, D. C. He was born on March 23, 1862, at Marathon, N. Y. As a young man he went to Colorado and began railway work with the Chicago, Burlington & Quincy as a blacksmith. He later was made machinist, and subsequently became fireman and engineman. Nine years ago he was appointed an inspector in the Division of Safety Appliances of the Interstate Commerce Commission; and on March 2, 1911, was appointed chief inspector of locomotive boilers by President Taft, with headquarters at Washington. He was a member of the Brotherhood of Locomotive Engineers and a member of the Washington Society of Engineers. Mr. Ensign had spoken on safety appliances and the inspection of locomotive boilers before different railway clubs and other organizations.



J. F. Ensign.

**Equipment and Supplies.****LOCOMOTIVE BUILDING.**

THE PENNSYLVANIA RAILROAD has ordered 50 locomotives from the Baldwin Locomotive Works.

THE GREEN BAY & WESTERN has ordered 1 mogul locomotive from the American Locomotive Company. The dimensions of the cylinders will be 19 in. x 26 in.; the diameter of the driving wheels will be 56 in., and the total weight in working order will be 138,000 lbs.

THE SPOKANE, PORTLAND & SEATTLE has ordered 2 six-wheel switching locomotives from the American Locomotive Company. These locomotives will be equipped with superheaters, will have 20 in. x 26 in. cylinders, 51 in. driving wheels, and in working order will weigh 154,000 lbs.

THE SAN PEDRO, LOS ANGELES & SALT LAKE has ordered 8 oil-burning mikado locomotives from the American Locomotive Company. These locomotives will be equipped with superheaters, will have 26 in. x 28 in. cylinders, 63 in. driving wheels, and in working order will weigh 285,000 lbs.

**CAR BUILDING.**

THE CHICAGO, MILWAUKEE & ST. PAUL is in the market for 10 sixty-foot mail cars.

THE LONG ISLAND has ordered 40 motor passenger cars, 20 express cars, 15 motor combination passenger and baggage cars, 12 coaches and 3 combination passenger and baggage cars from the American Car & Foundry Company. These cars will all be of steel construction throughout.

THE GREAT NORTHERN, mentioned in the *Railway Age Gazette* of September 19 as having ordered 125 passenger cars from the Pullman Company and the Barney & Smith Car Company, has not placed this order, but is figuring on 50 coaches, 25 baggage cars, 20 sleeping cars, 25 postal cars and 10 observation cars.

THE CHICAGO & NORTH WESTERN, mentioned in the *Railway Age Gazette* of September 26, as being in the market for 1,000 gondola cars, is now making inquiries for from 2,000 to 2,500 gondola cars, 36 coaches, 27 smoking cars, 30 baggage cars and 8 mail cars; all these cars to be of all steel construction.

**IRON AND STEEL.**

GENERAL CONDITIONS IN STEEL.—Conditions in the steel market continue to be very much the same. Orders have been light during the past week, but the railroads are figuring on their rail requirements for 1914, and a number of heavy orders are expected in the near future. It is believed that if these orders do not come up to expectations, a number of mills will have to reduce their operations. Reports from abroad regarding the steel industry are discouraging. In Great Britain five blast furnaces have closed and prices for steel in Germany continue to sag. Based on foreign prices and prices in this country, many classes of steel can be laid down by Europe at Atlantic seaboard ports under the new tariff at a profit. The margin is wide enough to warrant the statement that foreign steel can be sold profitably pretty far into the interior in competition with domestic mills. These facts have been appreciated by consumers, with the result that they are holding up orders as far as possible.

ARGENTINE CROPS.—The crops in the Argentine, on which satisfactory and remunerative traffic receipts principally depend, in a promising condition. The rains that have recently fallen throughout the cereal zone have improved the various crops under cultivation. The sugar and wool crops have also benefited by the good weather conditions. From the present outlook there is every probability that the railways will show a marked expansion in their receipts during the coming year.

## Supply Trade News.

D. P. Lamoreux has resigned his position as president and general manager of the Beaver Dam Malleable Iron Company, Beaver Dam, Wis., to engage in other business. Mr. Lamoreux's present address is 1658 McCormick building, Chicago.

William L. Garcia, who has been with the Fairbanks Company, New York, for the past eight years as manager of its engineering and power transmission department, has resigned to take the same position with Flint & Chester, Inc., New York, effective October 6.

The Erie Foundry Company, Erie, Pa., has recently received an order for the installation of a steam hammer at Princeton, W. Va., for the Virginian Railway, and another for the installation of a steam hammer at Fort Wayne, Ind., for the Pennsylvania Lines West.

Manning, Maxwell & Moore, Inc., New York, has purchased the entire capital stock of the Putnam Machine Company, Fitchburg, Mass. The Putnam Machine Company is the pioneer machine tool manufacturer of the country, and was started in 1836 by Salmon W. Putnam and John Putnam. The plant now covers about 14 acres. By the purchase, the old officers and directors of the Putnam company automatically cease to hold office, and the following are new directors: Salmon W. Putnam, Alfred J. Babcock, John N. Derby, Percy M. Brotherhood and George D. Branston.

C. C. Bradford, manager of the Cleveland office of the United States Light & Heating Company, New York, has been made sales manager of that company, with office in New York; and R. B. Clark has been made acting manager of the Cleveland office, suc-

cessing Mr. Bradford. Mr. Bradford was born in Caldwell, Kan., on May 27, 1880. In his early youth he moved to Cleveland, Ohio, where he received his schooling. He graduated from the Case School of Applied Science in the electrical course. Mr. Bradford started his business career with the Willard Storage Battery Company, Cleveland, and became manager of the Chicago office of that company and then manager of the New York office.

He resigned the latter position to go to the General Vehicle Company, Long Island City, as assistant sales manager. He remained with that company until 1909, when he was made manager of the New York office of the United States Light & Heating Company. After one year the branch office at Cleveland, Ohio, was established and Mr. Bradford was made manager, which position he retained until his appointment as sales manager with office at New York, as mentioned above.

### TRADE PUBLICATIONS.

**PNEUMATIC TOOLS.**—The Chicago Pneumatic Tool Company has issued Bulletin No. 148 on hand drills and portable compressors.

**METAL FLUMES.**—The California Corrugated Culvert Company, Los Angeles, Cal., has issued an illustrated booklet describing the Lennon smooth metal flume made from American pig iron.

## Railway Construction.

**CANADIAN NORTHERN.**—An officer writes that contracts have recently been given to D. J. McDonald and to the Nettleton-Bruce Eschbach Company, to build 20 miles of the Canadian Northern Pacific from Patricia Bay into Victoria on Vancouver Island, B. C. (January 23, p. 190.)

**CANADIAN NORTHERN PACIFIC.**—See Canadian Northern.

**CHICAGO, BURLINGTON & QUINCY.**—An officer writes that track on the line building from Powder River, Wyo., southeast to Orin Junction, 108 miles, has been laid to Casper, beyond which point the company will not lay any track this winter. Mixed trains will probably begin running from Casper west in October. Twohy Bros., Portland, Ore., have the contract for building this remaining link of the new route between Denver, Col., and Billings, Mont. (February 21, p. 373.)

**GULF, FREEPORT & NORTHERN.**—This company, which was recently incorporated in Texas to build from Freeport, Tex., northwest to Sealy, about 100 miles, has begun grading work, it is said, and the work will be pushed to completion. At Sealy connections are to be made with the Missouri, Kansas & Texas, and the Gulf, Colorado & Santa Fe. C. L. Sharp, vice-president and general manager; C. E. Clark, treasurer, Freeport. (July 25, p. 169.)

**KANSAS, OKLAHOMA & SOUTHWESTERN.**—An officer of this company, which was organized some time ago, writes that the plans call for building from Caney, Kan., southeast via Wann, Okla., Delaware and Nowata, to Vinita, about 60 miles. The line is to have maximum grades of one per cent., with six degrees of curvature. A contract was given last year to the Continental Construction Company, Caney, Kan., to carry out the work, which calls for handling 25,000 cu. yds. to the mile. S. M. Porter, president, Caney, Kan., C. J. Dalton, chief engineer, Lawrence.

**NUECES VALLEY, RIO GRANDE & GULF.**—Incorporated in Texas with \$25,000 capital and headquarters at Bellville, Austin county. The plans call for building from a point about a quarter of a mile east of Kitty, on the San Antonio, Uvalde & Gulf in Live Oak county, west to a point near the center of McMullen county, 25 miles. The incorporators include: J. H. Shary, Omaha, Neb.; W. A. Matthaet, H. F. Granau, C. R. Johnson, J. W. Brooks, H. T. von Rosenberg and R. E. Zeiske, all of Bellville, Texas, and J. W. Atkinson, Tilden.

**OKEECHOBEE INTERURBAN.**—An officer writes that this company has been organized with \$1,000,000 capital and headquarters at Arcadia, Fla. The plans call for building from Arcadia southeasterly over Joshua creek, thence east to Kissimmee river, and eventually to the east coast of Florida, with a branch from this line southeast via Bigler, Hall City, Palmdale and May Port, to the mouth of Fisheating creek. An extension is also to be built to connect with Fort Myers, via LaBelle, and another line to connect with Sebring via Lake Childs. E. Prouty, manager, Arcadia, Fla.

**OREGON-WASHINGTON RAILROAD & NAVIGATION COMPANY.**—The West Coast, which was incorporated some time ago, to construct a new line over the Cascade mountains, from North Yakima, Wash., west to Puget Sound, it is said, recently filed plats and locations of a right of way through the Naches Pass. The route from North Yakima follows Naches river and the north fork of that river to the summit. On the west slope of the Cascades the line will follow White river through Buckley to a connection with the O.-W. R. & N. tracks near Auburn.

**PORCUPINE RAND BELT ELECTRIC.**—A charter was granted to this company last year to build lines through northern Ontario. The promoters are asking for a provincial grant of \$4,000 per mile or a provincial guarantee for the bonds of several thousand dollars a mile. The line is to be built through a rich timber and agricultural section from the boundary of Ontario and Quebec immediately north of Larder and Oposatika lakes, crossing the Blanche river at Beaver House lake, and skirting Gull, Crystall and Kirkland lakes to a point on the Temiskaming & Northern Ontario north of Swastika, thence crossing that road west by



northwest to the Mettagami river. A connection is to be made with the T. & N. O. near Porcupine by a branch running north along the river. Another branch is projected across the Mettagami river to a connection with the Canadian Northern at Flying Post. The principal branch will parallel the inter-provincial boundary, running north from a point between Larder and Oposatika lakes to Abitibi lake, and south to North Temiskaming and New Liskeard. W. J. James is vice-president, and James H. Tighe, managing director of the Porcupine Construction Company is interested.

**SACRAMENTO VALLEY (Electric).**—An officer writes that the company will let contracts this coming winter to build from Red Bluff, Tehama county, Cal., south via Corning, Orland, Willows, Woodland and Dixon to Rio Vista in Solano county, about 160 miles. This work has been under consideration for some time, and the company expects to carry out the work during 1914. C. L. Donohoe, president; Melville Dozier, Jr., chief engineer, San Francisco.

**TRI-STATE RAILWAYS COMPANY (Electric).**—Incorporated in Michigan with \$100,000 capital, to build from Pioneer, Ohio, where a connection is to be made with the Toledo & Western, north to Hillsdale, Mich., about 20 miles. H. McClaue, C. H. Heller and M. T. Davis, of Hillsdale, and W. E. Elliott, Chicago, are interested.

**UTAH ROADS.**—According to press reports plans are being made to build from Wanship, Utah, on the Union Pacific, south-east to Kamas, about 15 miles. J. G. Jacobs, associated with capitalists of Salt Lake City, is understood to be back of the project.

**WATERLOO, CEDAR FALLS & NORTHERN.**—An officer writes that work is now under way building an extension from Urbana, Iowa, southeast to Center Point, six miles. A contract for the grading work has been given to R. A. Elzy, Marshalltown, and for the bridges to the Gould Construction Company, Davenport. The work involves handling about 20,000 cu. yds. a mile. The maximum grades will be 1 per cent., and the maximum curvature 2 deg. There will be one steel 21 ft. I-span bridge, and three creosoted timber trestles with ballasted deck, 150 ft. long. A station and a sub-station will be constructed at Center Point.

**WEST COAST.**—See Oregon-Washington Railroad & Navigation Company.

### RAILWAY STRUCTURES.

**ANTIGONISH, N. S.**—Bids are wanted October 3, by L. K. Jones, assistant deputy minister and secretary of the department of railways and canals, Ottawa, Ont., for constructing substructures of bridges on the Canadian Government Railways as follows: Over the West river at Antigonish, Nova Scotia; over Nashwaak river, New Brunswick, and over brook near Covered Bridge, N. B.

**CENTER POINT, IOWA.**—See Waterloo, Cedar Falls & Northern under railway construction.

**CHARLOTTE, N. C.**—An officer of the Norfolk Southern writes that work will be started in October on a six stall, square engine house, to be built at North Brevard street, Charlotte. The building is to be of brick construction, 90 ft. x 100 ft., and will cost about \$15,000.

**FAIRBURY, NEB.**—The Chicago, Rock Island & Pacific has awarded a contract to E. T. Leek & Company, of Chicago, for a new passenger station to cost approximately \$40,000.

**OLNEY, PA.**—An officer of the Philadelphia & Reading writes that contracts have been let for abolishing four grade crossings to the McNichol Paving & Construction Co., Philadelphia, for the grading and masonry work, and to the American Bridge Company, New York, for the bridges. The crossings to be abolished are on the Philadelphia, Newton & New York, near Olney, at Taber, at Mascher, and at Fisher streets, and at Duncannon avenue.

**SALINA, KAN.**—The Union Pacific has received bids for the construction of a new passenger station to cost approximately \$50,000.

## Railway Financial News.

**COLORADO MIDLAND.**—See Denver & Rio Grande.

**CONNECTICUT RIVER RAILROAD.**—H. E. Folsom has been elected a director, succeeding Charles S. Mellen.

**DENVER & RIO GRANDE.**—The United States district court has sustained the sale of 7,731 shares of stock of the Rio Grande Junction to the Denver & Rio Grande. The sale of this stock had been opposed by the trustee for the bonds of the Colorado Midland. Heretofore the Rio Grande Junction had been owned jointly by the D. & R. G. and the Midland.

**DETROIT, TOLEDO & IRONTON.**—George P. Johnson, receiver, has notified the district courts that he desires to resign.

**LOUISVILLE & NASHVILLE.**—Stockholders have authorized the directors to make an offer for purchase outright of the North & South Alabama. The road has been operated by the L. & N.

**MISSOURI, OKLAHOMA & GULF.**—The directors of the Oklahoma City Terminal Railway, which has been receiving bonuses for the Missouri, Oklahoma & Gulf Terminals at Oklahoma City, have notified the Missouri, Oklahoma & Gulf that unless the company could show conclusively that it was ready to build the line from Oklahoma City to Henryetta, subscriptions to the bonus fund would be returned to subscribers.

**NEW YORK, ONTARIO & WESTERN.**—The directors have elected Howard Elliott chairman of the board and confirmed the election of John B. Kerr as president.

**PARAGOULD SOUTHEASTERN.**—See St. Louis Southwestern.

**PENNSYLVANIA RAILROAD.**—A brief announcement was made at the end of last week that the company had decided to sell its securities of coal companies. The Pennsylvania owns a controlling interest in the securities of the Susquehanna Coal Company and affiliated companies, which coal companies owned or operated about 17,000 acres of anthracite coal lands.

A block of bonds—the amount is not stated—of the Allegheny Valley, guaranteed by the Pennsylvania Railroad, has been sold to Kuhn, Loeb & Co., New York.

**RIO GRANDE JUNCTION.**—See Denver & Rio Grande.

**ST. LOUIS & SAN FRANCISCO.**—A new protective committee to represent the interests of the stockholders has been formed as follows: Eugene Thayer, of Boston; Stacey Richmond, of Winslow Lanier & Co., New York; Frederick Bull, of Edward Sweet & Co., New York; and Charles H. Sabin, vice-president of the Guaranty Trust Company, New York. James Campbell recently sent a letter to stockholders offering to join with other stockholders to protect stockholders' interests without, however, the deposit of stock or the formation of a stockholders' protective committee.

**ST. LOUIS SOUTHWESTERN.**—Stockholders are to vote on October 7 on the question of leasing the Paragould Southeastern and guaranteeing principal and interest on the first mortgage 5 per cent. bonds. The Paragould Southeastern runs from Paragould, Ark., to Blythesville, 37 miles.

**SAN ANTONIO, UVALDE & GULF.**—This company has asked the approval of the Texas railroad commission for an additional issue of \$800,000 bonds.

**SOUTHERN RAILWAY.**—It is understood that plans are being tentatively discussed for a new refunding mortgage which will provide for future capital requirements and refunding under a more comprehensive plan than is permitted by the present improvement and refunding mortgage. Plans have not passed the preliminary stage, however.

**SOUTH AFRICAN LINE COMPLETED.**—The formal and official opening of the George-Oudtshoorn line, for all classes of traffic, took place on August 6.

**FORTY KILLED IN RUSSIAN WRECK.**—A press despatch from Rostov, Russia, September 29, reported the wrecking of a passenger train, between Baku and Batum, by brigands, who tore up the track. Six cars were destroyed and 40 persons were killed. More than a hundred were injured.

# Railway Age Gazette

PUBLISHED EVERY FRIDAY AND DAILY EIGHT TIMES IN JUNE, BY THE  
SIMMONS-BOARDMAN PUBLISHING COMPANY,  
WOOLWORTH BUILDING, NEW YORK.

CHICAGO: Transportation Bldg. CLEVELAND: Citizens' Bldg.  
LONDON: Queen Anne's Chambers, Westminster.

E. A. SIMMONS, *President.*

L. B. SHERMAN, *Vice-President.* HENRY LEE, *Sec'y & Treas.*  
The address of the company is the address of the officers.

EDITORS.

SAMUEL O. DUNN, *Editor.*

ROY V. WRIGHT, <i>Managing Editor.</i>	H. H. SIMMONS	E. S. FAUST
W. E. HOOPER	H. F. LANE	F. W. KRAEGER
B. B. ADAMS	E. A. AVERILL	A. D. CLOUD
E. T. HOWSON	R. E. THAYER	GEORGE L. FOWLER
	A. C. LOUDON	

Subscriptions, including 52 regular weekly issues and special daily editions published from time to time in New York, or in places other than New York, payable in advance and postage free:

United States and Mexico	\$5.00
Canada	6.00
Foreign Countries (excepting daily editions)	8.00
Single Copies	15 cents each

Engineering and Maintenance of Way Edition and four Maintenance of Way Convention Daily issues, North America, \$1.00; foreign, \$2.00.

Entered at the Post Office at New York, N. Y., as mail matter of the second class.

WE GUARANTEE, that of this issue 8,200 copies were printed; that of those 1,200 copies, 6,607 were mailed to regular paid subscribers and 345 were provided for counter and news companies' sales; that the total copies printed this year to date were 353,359—an average of 8,618 copies a week.

VOLUME 55. OCTOBER 10, 1913. NUMBER 15.

## CONTENTS

<b>EDITORIAL:</b>	
Editorial Notes	639
The Trespass Problem	640
Fitness First; Seniority Afterwards	641
*St. Louis Southwestern	641, 685
*Chesapeake & Ohio	642, 681
Hocking Valley	644, 684
New Books	645
<b>LETTERS TO THE EDITOR:</b>	
*A Deflectable Headlight; by J. R. Pratt	645
Freight Car Earnings; by Henry S. Prichard	646
Giving Agents Detailed Information About Freight Cars; by W. E. Brown	646
<b>MISCELLANEOUS:</b>	
*The Standard Locomotive Stoker	647
How the Railways Have Fared Since 1902; by S. W. Dunning	650
*Canadian Northern Montreal Terminal	651
The Claim Department—An Asset; by L. Moore	655
The Coal Mining Adjuncts of Railroads; by John D. A. Morrow	656
*Features of the Kalka-Simla Railway; by Lewis R. Freeman	657
Some Aspects of Railway Regulation; by Frank J. Loesch	659
*Boston & Maine Extension from Hinsdale, N. H., to Brattleboro, Vt.	661
Automatic Stops and Audible Signals	663
A Novel Plan for Solving the Railway Labor Problem; by George A. Clark	663
*Safety Squirt for Sprinkling Coal	664
*Hydraulic Forging and Bending Press	665
General Railway Notes	646, 649, 650, 654, 656, 658, 662, 663, 665
<b>GENERAL NEWS SECTION</b>	666

\*Illustrated.

**R**EPRESENTATIVE R. B. STEVENS, of New Hampshire, chairman of a sub-committee of the House committee on interstate and foreign commerce, is the author of one of the many bills now being drafted in Washington to cure the ills of railroad management. Whether or not Mr. Stevens fully realizes the crudity and futility of the scores of bills that have been introduced during the past ten years we do not know; but certainly on one point he sees straight. He says: "Congress is too slow-moving a body to handle this question adequately. We are always ten years behind the times. The railroad problem should be solved by a small body of experts who are making a life study of it, rather than by 435 members of Congress who know nothing about the subject technically. Fifty bills are now pending in Congress on this subject. The

way to deal with the problem is to turn the whole question over to the commission, with power to act when occasion demands." It might have been added that the commission itself is nearly ten years behind the times in some of these matters. It recommended the general use of the block system in December, 1903; but it has not yet stirred Congress to take action. It had the power to investigate accidents in 1910; but even now, September, 1913, its recommendations lack definiteness, and in some cases are injudicious. Mr. McChord has investigated three train accidents in Connecticut; but his last report says that not until next December will the commission be ready to propose anything specific. And it is to be hoped that Congressman Stevens is more intelligent than are some congressmen in the use of the term "small body of experts." The seven lawyers and publicists constituting the commission do not pretend to call themselves a body of experts in railroad operation, though some congressmen seem to assume that they do. The Block Signal Board recommended that a body of real experts, like the British Board of Trade, be established, but the commission refused to endorse the recommendation. In boiler inspection, and in valuation of railway property, the commission has carried out the "expert" idea with some degree of wisdom; but the notion that congressmen and politicians, rather than cold and scientific engineers, should decide all important questions seems still to have far too much influence in Washington.

**T**WO features were particularly noticeable at the recent conference of the apprentice instructors of the New York Central & Hudson River. One was that less and less attention is being given to the study of mechanical drawing and more and more to the making of rough sketches, such as are often required in shop work, and in the reading of working drawings and blue prints. What is needed is the development of skilled mechanics, and not draftsmen. If any of the boys show promise of developing along engineering lines, then they can find opportunity for further study outside of the apprentice schoolroom, and possibly with the aid of the railway company. This is as should be. The other tendency, while, though it is not new and has been in course of development ever since the modern apprenticeship system was established on the New York Central, is of even greater importance. It is a more vivid realization of the fact that the individual characteristics of each one of the boys must be carefully studied, and that the development along moral lines is of just as much importance to the company as the progress in skill and knowledge of the craft. H. S. Rauch, apprentice instructor at the Avis, Pa., shops, brought out clearly that each apprentice must be given close individual attention and study in order that he may be assigned to that class of work for which he is best fitted, else he will not be happy and cannot do his best work. He must also be given a broad training, that he may develop into a loyal employee and good citizen. Last, but not least, the attempt must be made to develop his character with a view to moral cleanliness, honesty, sobriety and sincerity. This may seem to smack too much of the ideal, but it is possible of accomplishment, and the best apprentices are to be found at those shops where this ideal is most nearly approached.

**W**E did not find as much trouble getting the stokers in full operation as we did either the air brake apparatus or the superheater." This is the statement of a motive power officer who had received 100 very heavy Mikado type locomotives from the builders which were equipped with stokers and superheaters. All of the stokers gave 100 per cent. service the first trip over the road and maintained this record practically unbroken thereafter. In view of the length of time that the stoker has been a commercial proposition, this is really a wonderful performance. Investigation shows, however, that this is not the only instance of the

kind, as the same record has been made on other roads that have received a smaller number of new stoker locomotives. While this absence of trouble at the start is very satisfying, the reliability which the machines have shown later in regular service is even more so. Records covering a large number of locomotives for a considerable period show that the average cost of maintenance is but one-half cent per locomotive mile, a figure which the most ardent advocate of stokers would hardly have dared to suggest a year or so ago. One master mechanic who has a number of stoker engines under his jurisdiction writes that so far as trouble is concerned he would not know that he had a stoker locomotive on the division. What a condition of this kind means to the railroad can be easily understood. Recently an entirely new design of stoker was applied to a large locomotive and from the first trip and during the past three months' service not a single shovel of coal has been put in the firebox by hand, although the engine is in heavy freight service. This indicates that the stoker manufacturers have fully familiarized themselves with the conditions they have to meet and credit is due them for a record that has never been made by any locomotive device of similar importance in an equal length of time. There are at the present time nearly 1,000 locomotive stokers in operation in this country.

THE Canadian Northern has had under construction during the year about 2,500 miles of road, including the Port Arthur-Montreal connection and the Edmonton-Vancouver extension which will complete the transcontinental line from Quebec to Vancouver. This work is being pushed at maximum speed, as indicated by the fact that during 1912 the company completed an average of over 1½ miles of new line per day. It is expected to have the entire main line ready for operation before the end of next year. Although the Canadian Northern is not to be compared in point of age or financial backing with its two principal competitors in the Canadian field, it has been developed in small units by careful financing on small capital until it will shortly be in position to compete actively for its share of the transcontinental business. The dominion and provincial governments encourage in a substantial manner the building of new railways which will help in the development of the vast agricultural and mineral resources of the country, but this help does not extend to the securing of well located and adequate terminal facilities which are so essential in handling business. The manner in which the Canadian Northern has overcome the indifference of the people of Montreal and the opposition of the other roads, is described in an article on the Montreal terminal published elsewhere in this issue. A large passenger and freight terminal in the very center of Montreal was necessary if the new line was to compete on an even basis with the older roads. Montreal is the chief city of the dominion in many respects and during the busiest season of the year it is the eastern seaport for the company's Atlantic steamers which will deliver a large amount of business to the road. The city was already well served by trunk lines, one of which is 50 years older than the new company, and was provided with well located passenger and freight terminals. The natural entrances to the city were all occupied, and to parallel the existing lines would have meant a long section of unprofitable line, so the bold plan of tunneling under Mt. Royal to locate a passenger station in the heart of the business district and a freight station along the river front was adopted. The cost of this terminal is expected to reach at least \$20,000,000 and in order to meet a part of this large investment, the company is developing a suburban district back of the mountain. The tunnel will provide a short connection with the city and as the entire terminal is to be electrified it is expected to establish a service that will be very attractive to suburban residents. The boldness of the

promoters in undertaking such a vast project, their ingenuity in planning to recoup a portion of the expense by this development and their skill in carrying out the work as indicated by the fact that a world's tunneling record has already been broken, are attracting wide attention among railway men. Such projects are only undertaken under such a stress of competition as exists in the Canadian field at present.

#### THE TRESPASS PROBLEM.

THE need of a national law prohibiting trespassing on railway tracks was strongly emphasized in an article by Marcus A. Dow, general safety agent of the New York Central Lines, in the *Outlook* of September 27, 1913. Several railways have made strenuous efforts to get public authorities interested in co-operating with them to reduce this evil, but with more or less indifferent results. In some states—New York in particular—ample legislation has been effected, but the magistrates have been slow in punishing offenders, partly because of the expense to the community when they are found guilty and imprisoned because of inability to pay the fines imposed, partly because of ignorance as to the exact provisions of the law, and partly also in some cases because the magistrates felt that the public should be more thoroughly warned against committing the offense before punishment was imposed.

Statistics of death and injuries to trespassers indicate that roughly only 25 per cent. of the trespassers are car riders and that the other 75 per cent. are track walkers. Of this 75 per cent., F. V. Whiting, general claims attorney of the New York Central Lines, has shown that over 75 per cent. are responsible citizens living in the vicinity of the road, or women and children. The larger portion of the track walkers are, therefore, not in the hobo class, and a fine imposed upon these for trespassing on railway property would do much to discourage the guilty ones from repeating the offense and would have a salutary effect on their neighbors. With this in mind, the New York Central has assigned one of its representatives to the task of visiting and conferring with the magistrates in order to secure their co-operation, and also to get in touch with the local newspapers, which, by their comments, may prove of great assistance in educating and warning the public about the dangers of trespassing. This representative has been engaged in the work since the first of August and thus far has devoted his efforts to those parts of the line where accidents to trespassers are most frequent.

In connection with this the railroad has renewed its efforts in warning the trespassers by the posting of suitable notices, and has been more active in policing the right of way. The statement has been made by one who has been intimately associated with those who are most active in trying to discourage trespassing, that if all of the states had adequate and uniform trespass laws, or if there was a national law prohibiting trespassing on railway property, and if a campaign of education was waged among the magistrates, public authorities, and the public generally, and the railways would do their part in apprehending and arresting trespassers, the evil could be practically eliminated in this country inside of six months.

Mr. Dow, in urging the enactment of a national law, says: "We are the only civilized nation in the world that has no national law prohibiting, under the penalty of a penitentiary sentence, trespassing on railway tracks, and in those few states where there are such laws, there is a woeful neglect to enforce them. The total number of railway employees and passengers killed on our railways each year is less than the total number of trespassers killed; and if it is worth while for the railways to spend millions of dollars to install and improve safety devices to prevent the killing of their own employees and passengers, why, I would ask, is it not worth while that some effective legislative action be taken by our government to protect and save the lives of more than 5,000 trespassers annually, and the

limbs of many thousands more? It would not cost the nation a penny, and the saving to it of a vast economic loss, not only in the lives of its citizens, but in the reduction of its number of helpless cripples, would be inestimable."

#### FITNESS FIRST; SENIORITY AFTERWARDS.

THE conservative press very generally condemns the locomotive engineers of the New Haven road for starting up their strike machinery simply because of disagreement concerning what seems to be only a technicality; because the company has announced new rules making fitness the first qualification, experience the second and seniority third, instead of seniority first, fitness second and experience nowhere. The issue is quite clear, even to the lay mind. Strikes depend on public sympathy and, with the case stated as it has been stated, it is easy to predict the opinion of all fair minded persons. It needs no argument to prove that a young man may be better fitted than an old one for a given critical task. But the case has not been properly stated; the newspaper discussion has not brought out the real issue. If the public is to be the jury the jurymen must dig deeper for the essential facts. The enginemen do not claim that seniority shall be absolutely the governing factor, and they feel aggrieved at being misrepresented. Of a number of editorial utterances, that of the *Providence Journal* may be taken as typical. This article says:

The New Haven engineers who are said to be taking a "strike vote" on the new rules which promise better discipline, evidently are unaware of the widespread disapproval of their position on the question of safety. The operating officers have been censured by state and federal boards for accepting rules which may give the preference to inexperienced men, and for failure to hold engineers and trainmen to strict accountability when orders are disregarded. It also is stated that a vice-president and the general manager, in the opinion of the engineers, should be discharged because they were especially conspicuous in the work of revising the rules and insisted that engineers who passed danger signals must not expect any help from the grievance committee. The duty of the New Haven management is to submit to no dictation on questions of discipline. Public safety is all important, and any proposition which weakens the authority of the superintendent should be rejected. The rule of seniority, cherished by the engineers, is bad in that it may compel the operating officers to select the men least fitted for positions of responsibility. An engineer of five-years' experience may be more competent than one who has run locomotives 8 or 10 years. *The judgment of the superintendent as to qualifications should be unfettered.*

The enginemen's side may be seen from the following extract from an editorial in the *Locomotive Engineers' Monthly Journal*:

Seniority means experience, and experience means safety. One of the greatest wreck calamities in New England was caused by a violation of this rule, when a young engineer who had never been in passenger service was ordered with his freight engine to couple on ahead of a passenger train engine. There is no rule in our contractual relations with railroad companies more justified than the rule that the oldest in service shall have the preference in assigning men to important runs. They have served the companies longest and had the greatest experience. If a senior man is lacking in ability to perform the service *there is nothing to prevent the railway officials from establishing that fact and calling the next senior man to fill the place.*

The whole issue is embraced in the two passages which we have italicized. Mr. Bardo's purpose, evidently, is to introduce a rule which shall *shift the burden of proof*. The *Providence Journal* and other influential papers approve this change. Under the old rule seniority decides each case unless the superintendent can prove that seniority should not be the deciding factor. The superintendent is not absolutely prevented from taking the best men for the most important runs, but he is fettered. Under the new rule he is not held to such a strict requirement. The claim of the engineers is that the superintendent will be unfair. There have been superintendents on many roads who were unfair in such matters.

In the police department of New York City the spirit of revolt against the authority of the superintendent has gone so far that discharged policemen are allowed to go to the higher courts for vindication and reinstatement! The brotherhoods would be glad to introduce conditions like that into the

railroad service. Such a situation is intolerable. Delays and difficulties in administering discipline are responsible for half our troubles. Sometimes the superintendent himself is to blame; but the remedy for the misdoings of an unfair superintendent must be found in some other direction than that of suspending the regular course of business, perhaps a dozen times a month, while there is held a judicial inquiry—occupying perhaps a dozen men a dozen days—or else railroad operation will have to be handed over to the military authorities, as it was in France on the occasion of the recent strike in that country.

The superintendent who assigns runners and manages trains must have absolute authority, in that sphere, howsoever troublesome or costly may be the subsequent measures necessary to correct any injustice which may result from allowing that authority. The ideal superintendent is one who, like a well known officer that could be named, supplemented a decision dismissing an engineman by this declaration to the grievance committee: "Whether I hold my position seven minutes, or seventy years, this decision will stand!" Of course, to maintain that attitude a superintendent must be not only strong, but just. He must be a large size man.

When Mr. Whaley, some months ago, assumed his present position at the head of the operating department of the New Haven road, the New York reporters went to him at once for an interview. As he was taking an important position they quite naturally wanted an interview of respectable length. As the New Haven company had been loudly criticized for inefficient management they put forward, as their main point, a request for an outline of the principles on which Mr. Whaley proposed to manage the discipline of his subordinates. They got their answer in four words—"Be fair and firm." The only amplification of this that they could extort was that "if you are fair, then you can be firm." This was not very satisfactory to a reporter who had been ordered to get a half column; but if Mr. Whaley can carry out this policy there can be no doubt that it will be satisfactory to the public. On a road like the New Haven, with its scores of trainmasters and road foremen, and its hundreds of enginemen, the task is no easy one.

#### ST. LOUIS SOUTHWESTERN.

THE changes from year to year in the tonnage of the various products carried by the St. Louis Southwestern is typical of the growth of the country served. The St. Louis Southwestern runs from St. Louis down the east side of the Mississippi river to Thebes, there crosses the river, running down through southeastern Missouri, eastern and southern Arkansas, and spreading out in Texas reaches Dallas, Fort Worth and Waco. Thus, the "Cotton Belt" taps the "black land" cotton belt of Texas and also gets into the timber country of east Texas and eastern Arkansas.

Of the total tonnage carried on the St. Louis Southwestern in 1913, 23 per cent. was products of agriculture, of which cotton and cottonseed products made up a little less than half; 39 per cent., products of forests; 25 per cent., manufactures and miscellaneous; 2.54 per cent., livestock and animal products, and 10.68 per cent., products of mines. The tonnage of products of agriculture increased by 2 per cent. in 1913 over 1912; products of forests, 10 per cent.; manufactures, 12 per cent.; livestock and animal products, 23 per cent.; and products of mines, 15 per cent. With its comparatively large tonnage of timber the St. Louis Southwestern gets a northbound haul which is important in helping to give it a larger average trainload. In 1913 the total tonnage of all products carried was 3,726,000 tons, of which 54.23 per cent. was northbound and 45.77 per cent. southbound. As the timber is cleared off, farms are being established, and although the growth in the tonnage of products of agriculture was but 2.11 per cent. in 1913, the growth of the *diversity of farming* is indicated by an increase of 117 per cent. in the tonnage of oats; 41 per cent. in the tonnage of grain other than rice, corn, oats

and wheat; 33 per cent. in the tonnage of tobacco, and 66 per cent. in the tonnage of fruit and vegetables. Cotton is not a particularly important commodity on the St. Louis Southwestern except in so far as a good cotton crop means a prosperous territory demanding increased manufactured products, etc. The great bulk of the cotton grown in central and eastern Texas moves to the seaboard at Galveston or other Gulf ports and on this traffic the St. Louis Southwestern can get but a comparatively short haul.

In the annual report for the fiscal year ended June 30, 1913, there is nothing to indicate that it would be found advisable to reduce the preferred dividend (which action has, however, been taken by the directors), unless it be the mention of the fact that the United States Supreme Court had upheld the rate reductions in Missouri and in Arkansas. Last year the St. Louis Southwestern, operating 1,609 miles, earned \$4,081,000, as against \$3,623,000 the year before; and after the payment of expenses, taxes and interest there was \$1,886,000 net available for dividends, as against \$1,618,000 available for dividends at the end of 1912. Since dividends call for a little less than a million dollars, the company showed a comfortable surplus in both 1913 and 1912. Expenses, of course, were higher last year than the year before, as would be expected with a larger business

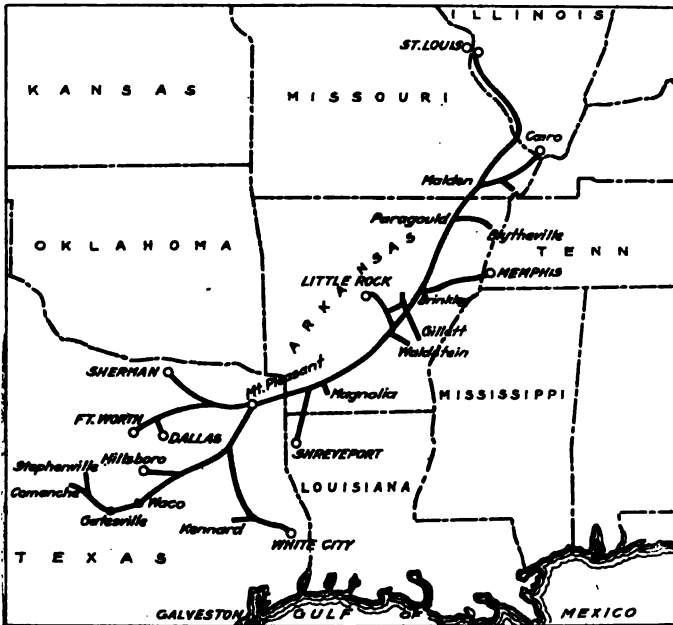

The St. Louis Southwestern.

handled; but the operating ratio was 69.31 in 1913, as compared with 69.92 in 1912, and by far the largest part of the increase in expenses was in maintenance of way. The increase on this account was \$422,000, or 28.60 per cent., and the total in 1913 was \$1,899,000. Thus, the company spent \$1,180 per mile. The standard on the main track of the St. Louis Southwestern is 75-lb. rail, ballasted with gravel and sand, although the company has about 189 miles of rock ballast and is at present ballasting some of its Texas lines with burnt clay.

The total ton mileage in 1913 was 871,986,000, an increase over 1912 of 4.34 per cent.; and the total passenger mileage was 100,170,000, an increase over 1912 of 14.22 per cent. Transportation expenses amounted to \$4,039,000 in 1913, an increase of 7.89 per cent. The average haul of freight was 234 miles in 1913 and 245 miles in 1912; and of passengers, 39 miles in 1913 and 37 miles in 1912. The receipts per ton per mile were 1.13 cents in 1913 and 1.07 cents in 1912; and the receipts per passenger per mile were 2.61 cents in 1913 and 2.62 cents in 1912. Of the total 1,609 miles, 145 miles are in Missouri and 565 miles in Arkansas, so that presumably the reduction in revenue, especially in passenger revenue, from the working of the state commission's rate reduction orders, will be quite considerable. To offset this

there is the rapid growth of population and of prosperity in the territory served and the increased efficiency of the effectiveness of the transportation plant. In 1913 the average train load on the St. Louis Southwestern, exclusive of Texas, was 461 tons, as against 447 tons in 1912, and on the Texas lines, 215 tons, as against 211 tons; so that the average train load on the entire system was 349 tons in 1913, as against 341 tons in 1912.

The following table shows the ratio of each class of expenses to total operating revenues:

	1913.	1912.
Maintenance of way .....	14.29	12.27
Maintenance of equipment .....	16.69	18.04
Traffic expenses .....	3.83	3.98
Transportation expenses .....	30.38	31.09
General expenses .....	4.12	4.54
Total .....	69.31	69.92

The only additional capital securities which were sold by the St. Louis Southwestern in 1913 were \$2,049,000 first terminal and unifying mortgage bonds, of which \$508,000 was used to retire outstanding securities, leaving a net increase of \$1,541,000, with a net property investment increase during the year of \$1,938,000.

The following table shows the principal figures for operation in 1913, as compared with 1912:

	1913.	1912.
Average mileage operated.....	1,609	1,548
Freight revenue .....	\$9,864,490	\$8,971,114
Passenger revenue .....	2,618,176	2,300,986
Total operating revenues .....	13,296,950	12,042,543
Maintenance of way and structures.....	1,899,484	1,477,069
Maintenance of equipment.....	2,219,390	2,172,269
Traffic expenses .....	508,894	479,154
Transportation expenses .....	4,839,413	3,744,143
General expenses .....	548,616	546,780
Total operating expenses .....	9,215,797	8,419,415
Taxes .....	468,697	458,512
Operating income .....	3,599,816	3,150,072
Gross income .....	4,644,141	4,047,915
Net income .....	1,886,191	1,617,619
Dividends .....	994,682	994,682
Surplus .....	891,509	622,937

CHESAPEAKE & OHIO.

THE Chesapeake & Ohio is one of the three or four roads that have shown in the last few years the most remarkable increase in average train load. In 1910, before the C. & O. had acquired its Chicago line, the average revenue train load was 701 tons and the total train load was 733 tons. In 1913 the revenue train load was 843 tons and the total train load 901 tons; and this included and was averaged down by the train load on the Chicago line. The train load on the Chicago line in 1911 was 325 tons for revenue freight and 347 tons for all freight; and while it is undoubtedly better than that now, it may easily be seen that an apparent increase of 20 per cent. in revenue train load and 23 per cent. in total train load represents a very much greater actual increase in train load on the C. & O. proper. Despite the increase in train load, however, expenses have increased out of proportion to increased revenues largely because transportation expenses *per train mile* have increased to a quite extraordinary degree. Nineteen ten was the banner year for the C. & O., and in that year the property earned \$6,290,000 net income after the payment of fixed charges, or about 10 per cent. on its stock. In 1913 the company earned \$3,299,000 net, or about 5.25 per cent. on its stock. The operation ratio in 1910 was 60.6 per cent. and in 1913 69.7 per cent.

To form an intelligent opinion as to the probable future earning power of the property we must separate the causes which have acted to make the 1913 showing less favorable than the 1910 showing into those that are temporary, those that are within the power of the management to eliminate, and those that are beyond the present power of the management to remedy.

The Chesapeake & Ohio is now a double track line from Newport News, Va., to Cincinnati, Ohio, and a single track line from Cincinnati to Chicago, having also a single track line from Ashland to Louisville, Ky. The company owns the majority of the stock of the Hocking Valley and a half interest in the Kanawha & Michigan. The double-track line between Cincin-

nati and tidewater is a low grade line built and maintained with the best modern standards. It runs through the Kanawha, the New river and taps the Kentucky coal fields and its grades from the coal fields to tidewater are better than those of either the Virginian or the Norfolk & Western. Between 60 and 70 per cent. of the total tonnage of the C. & O. lines, including the Chicago line but excluding the Hocking Valley, is bituminous coal. About one-third of the coal carried moves east to tidewater and the other two-thirds west, to be delivered to the Kanawha & Michigan for the Hocking Valley at Gauley; to the Cincinnati, Hamilton & Dayton at Kenova; to the Cleveland, Cincinnati, Chicago & St. Louis at Cincinnati; to the Chicago line at Cincinnati, and to other connections at Cincinnati. The control of the Hocking Valley was bought in 1910, and a little later the Chicago line was bought, but the Chicago line is only now getting in such shape as to permit of profitable operation. In 1911 the Virginian began operation and since then has been a competitor of the Chesapeake & Ohio for tidewater coal. In

is commented upon elsewhere; but to get its coal on to the Hocking Valley the C. & O. has to get it over the Kanawha & Michigan, which was probably pretty badly congested.

The floods, and the worst of the congestion on connecting lines, were temporary conditions which are not likely to occur again in the near future. The congestion on the Kanawha & Michigan will probably not very materially improve, although it is possible that the Chesapeake & Ohio may find some way of delivering a considerably larger volume of coal to its Hocking Valley line. The competition of the Virginian will grow stronger rather than weaker and will in all probability only be partially offset by increased production of coal. On the other hand, more and more coal is being mined from the Kentucky fields, and both general freight business and coal business for the territory between Cincinnati and Chicago is materially improving, along with the improvement in physical condition and in operation of the Chicago line. In 1913 freight tonnage other than coal and coke amounted to 8,811,000 tons, as compared

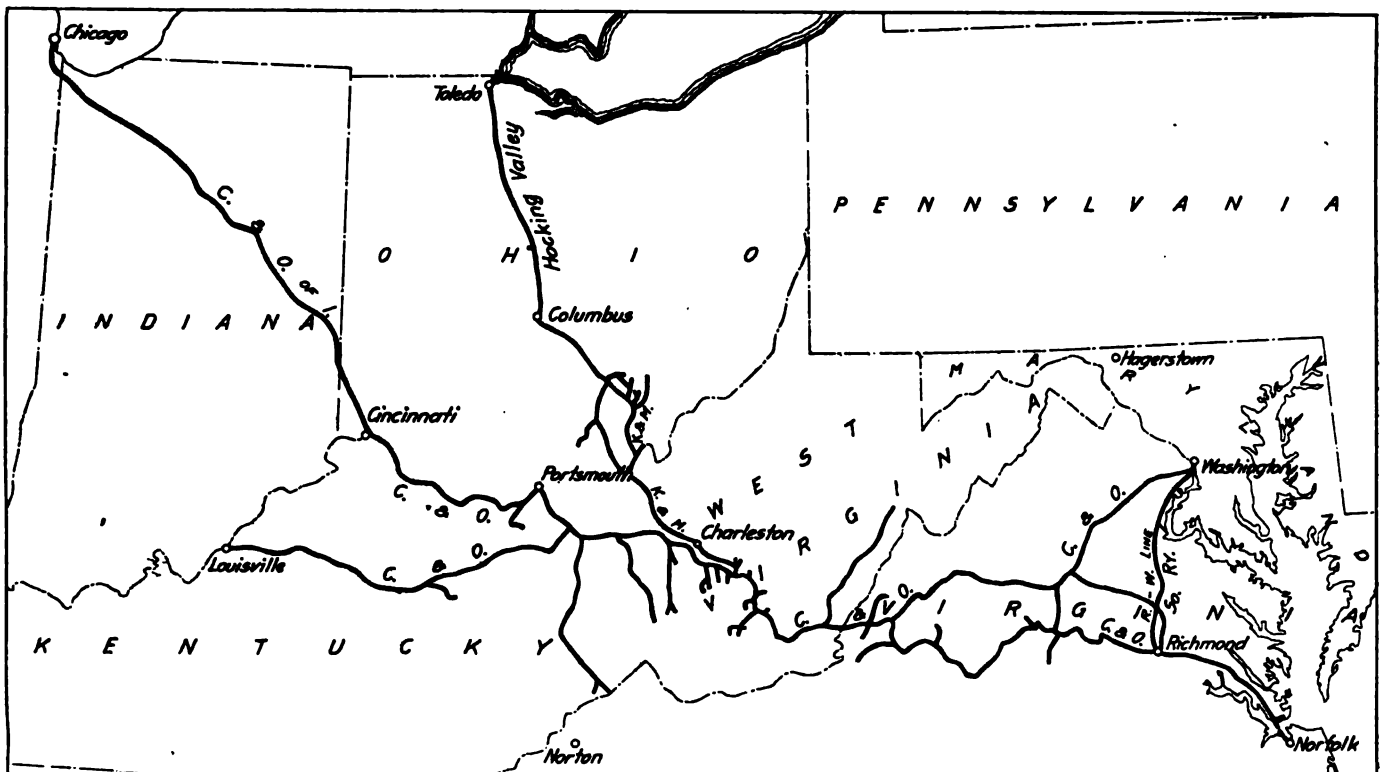

The Chesapeake & Ohio and the Hocking Valley.

1913 the total tonnage of coal carried on the C. & O. lines was 16,363,000 tons, as compared with 15,725,000 tons carried in 1910. The 1913 tonnage of coal and coke was less by 9.5 per cent. than the tonnage in 1912.

During 1913 there were strikes in the West Virginia coal fields; there were, of course, the unprecedented floods, and the added competition of the Virginian. The floods interrupted through traffic on the C. & O. only ten days, but, of course, affected expenses for both transportation and maintenance over a much longer period. More serious, however, even than the effect of the floods on the operation of the C. & O. itself was the inability of connections due to flood damage to accept deliveries from the C. & O. The Cincinnati, Hamilton & Dayton is not in particularly good physical condition, and was seriously affected by the floods. It, therefore, was not able during a very considerable part of the last six months to take anywhere near the tonnage which the C. & O. was able to deliver to it. The C. C. C. & St. L. was also damaged by floods and naturally, of course, had to take care of its own freight and New York Central freight first, so that it undoubtedly had to refuse quite a considerable amount of Chesapeake & Ohio coal. The Hocking Valley is in fine physical condition, and its showing in 1913

with 7,633,000 tons in 1910; and the 1913 business was an increase of 9.2 per cent. over the 1912 business.

While, of course, coal business is very profitable if a high ton mile rate can be obtained, because it is so comparatively cheap to handle, the C. & O. gets but 3.15 mills per ton per mile for its coal, while it gets 6.05 mills per ton per mile for freight other than coal. It would appear, therefore, that if the Chicago line both offers a market for C. & O. coal and lends itself to materially increasing the other freight business of the C. & O., the outlook for gross earnings is materially better than would be indicated by the increase of slightly over 1 per cent. in freight revenue in 1913 as compared with 1912. In this connection attention may properly be called to the increase in passenger revenue. In 1913 passenger revenue amounted to \$5,858,000, which is more by 6.4 per cent. than in 1912.

There remains the question as to whether or not the increase in expenses shown since 1910 is temporary or is beyond the control of the management.

Maintenance expenses on the Chesapeake & Ohio have for a number of years been on a liberal scale. Maintenance of way in 1913 cost \$4,343,000, or \$1,873 per mile of road. This compares with \$3,982,000 spent in 1912 and \$4,142,000 spent in 1911;

the 1910 figure is, of course, not comparable because it does not include the Chicago line. Maintenance of equipment cost \$7,275,000 in 1913, \$6,724,000 in 1912 and \$6,199,000 in 1911. The expenditures for repairs per unit of equipment for the three years is as follows:

	1913.	1912.	1911.
Per locomotive .....	\$2,624	\$2,700	\$2,479
Per passenger train car.....	844	839	803
Per freight train car.....	70	65	63

Transportation expenses in 1912 totaled \$11,381,000, comparing with \$10,503,000 in 1912 and \$10,044,000 in 1911; the 1910 total figures are not comparable because they do not include the Chicago line.

The large gain made in the past three years in train loading has already been mentioned, and total transportation expenses per unit of service (ton miles and passenger miles added) were 1.34 mills in 1910 and 1.63 in 1913. With such a very large gain in train load, however, there ought to be a much better result in transportation costs per unit per mile; and the explanation, of course, is that transportation expenses per train mile have so largely increased since 1910. In that year total transportation expenses per train mile, excluding mixed train miles, were 65.4 cents; in 1913 they were 86.5 cents. This is an increase of 32 per cent. While, of course, wages have shown a larger increase than fuel costs, even fuel costs appear to have gone up disproportionately when measured on a train mile basis. Thus the cost of fuel for road locomotives per train mile in 1913 was 11.1 cents, and in 1910 9.1 cents, an increase of about 22 per cent. Enginemen's and trainmen's wages in road service were 24.6 cents in 1913 and 19.0 cents in 1910, an increase of 29 per cent. We might surmise that the showing in train load had been effected by largely increased double heading and helper mileage, but this was not the fact. Total locomotive miles in freight service was 114 per cent. of freight train mileage in 1913 and 113 per cent. in 1910; and locomotive mileage in passenger service was 109 per cent. of passenger train mileage in 1913 and 105 per cent. in 1910. This is a comparatively small increase in freight helper mileage, and not a very large increase in passenger helper mileage.

The most noticeable increase in transportation expenses per train mile was in wages of yard enginemen and yard crews. In the aggregate of these items there was an increase of 50 per cent. between 1912 and 1913.

It is not an uncommon experience for a new management to make an excellent showing in increased train load, but have transportation expenses increase out of proportion, even so as to entirely offset the saving effected by larger train loads. During the process of putting new methods into operation and installing heavier power there are naturally delays in yard service, overtime for both yard and road crews, sometimes friction between the men and their officers, and all of those little problems which aggregate so large and which can only be overcome by time and patience. After the train load approximates the figure which the management has decided it should be, then attention can be turned to reducing transportation expenses per train mile, and one after another of these expenses can be brought down into line. This is the problem which the Chesapeake & Ohio apparently still has to face, the successful solution of which, however, should result not only in regaining the ground that has been lost, but in a very material advance in effectiveness of operation over what was the starting point.

The Chesapeake & Ohio directors, after the close of the fiscal year, decided to reduce the annual dividend rate from 5 to 4 per cent. The company earned only slightly over its full 5 per cent. in the fiscal year ended June 30, 1913, and not having any very large surplus to the credit of profit and loss (the surplus at the end of 1913 was \$2,515,000), conservatism even at the expense of the stockholder appeared to be entirely justified.

There is one statement in the 1913 annual report of the Chesapeake & Ohio that, so far as we know, is unique among the reports of American railroads in clearness and intelligibility in regard to capital expenditures. This statement shows the total

par value of each issue of capital securities sold in the four years ended June 30, 1913, the total being \$69,436,000, which realized for the company \$65,761,475. During this time the total par value of capital securities paid for or bought was \$18,076,000, which securities cost the C. & O. \$18,399,696, leaving a total of \$47,361,779 capital raised during the four years through the sale of securities. During these four years the C. & O. bought stock of other companies with a total par value of \$20,414,500, paying therefor \$20,645,046; and bonds (the C. & O. of Indiana first mortgage 5's) with a face value of \$6,589,000 at a cost of \$5,311,700; and the properties of three small roads at a cost of \$4,192,869. In addition the company spent for extensions and betterments \$14,080,052, \$1,637,883 for equipment, and \$11,166,743 for equipment through the C. & O. Equipment Corporation. This is a total capital expenditure of \$57,034,294, against which capital securities of a par value of \$51,360,000 were sold. The difference between \$51,360,000 and \$47,361,779, which is the amount realized by the company, is the sum of the premiums which the company had to pay for securities that it retired and the discount which it had to allow on its securities sold. The Chesapeake & Ohio would be a rather poor example for those who continue to talk about stock watering or over-capitalization.

The following table shows the principal figures for operation in 1913 as compared with 1912:

	1913.	1912.
Average mileage operated.....	2,319	2,263
Freight revenue .....	\$27,549,696	\$27,261,475
Passenger revenue .....	5,858,138	5,505,536
Total operating revenues.....	35,085,278	34,289,870
Maint. of way and structures.....	4,342,745	3,981,646
Maint. of equipment.....	7,275,439	6,724,460
Traffic expenses .....	669,016	636,967
Transportation expenses .....	11,380,998	10,503,415
General expenses .....	783,362	789,193
Total operating expenses.....	24,451,560	22,835,681
Taxes .....	1,375,863	1,014,220
Operating income .....	9,257,855	10,639,969
Gross income .....	11,483,392	12,448,532
Net income .....	3,298,503	4,274,206
Dividends .....	3,139,080	3,139,628
Surplus .....	159,423	1,134,579

#### HOCKING VALLEY.

THE Hocking Valley operates but 352 miles of road, of which but 47 is double tracked; but it earns more than \$22,000 per mile of road and handled in the fiscal year ended June 30, 1913, despite the floods, 4,136,000 ton miles per mile and 150,000 passenger miles per mile. This was an increase over 1912 of 5.5 per cent. in freight density, and about 1 per cent. in passenger density. Despite floods and very materially higher amounts spent for maintenance of equipment there was net income, after the payment of expenses, taxes and all fixed charges, of \$1,916,000 in 1913, as compared with \$1,831,000 in 1912.

Of the \$11,000,000 stock of the Hocking Valley, \$8,825,000 is owned by the Chesapeake & Ohio and the Chesapeake & Ohio stockholders' equity in the earnings, present and potential, of the Hocking Valley amounts to no inconsiderable sum. The Hocking Valley stock is deposited under the Chesapeake & Ohio first lien and improvement mortgage.

The Hocking Valley carried 11,179,000 tons of freight in 1913, of which 79.78 per cent. was products of mines, and of which total freight 47.35 per cent. originated on the Hocking Valley and 52.65 per cent. was received from connections. There are only a few roads in the entire country that have the freight density on single track that the Hocking Valley has. The Bald Eagle Valley line of the Pennsylvania is one, the eastern end of the main line of the Wheeling & Lake Erie is another; but even so, the Hocking Valley is not being operated to its fullest capacity.

In 1912 the average revenue train load was 852 tons, and this remarkably good train loading was bettered in 1913 by 16 per cent., making the revenue train load 988 tons and the total train load, including company freight, 1,023 tons. The tonnage per locomotive, including company freight, was 862 tons. With ton mileage greater by 5.6 per cent., transportation expenses amounted to but \$2,332,000, or about 4 per cent. more than in

1912. The saving during normal operation must have been larger than indicated by these figures, since, of course, for a part of the year the road was being operated under the abnormally expensive conditions created by the floods.

The following table shows the proportion of each class of expenses to total operating revenues:

	1913.	1912.
Maintenance of way.....	10.0	11.7
Maintenance of equipment.....	20.4	16.3
Traffic expenses.....	1.4	1.4
Transportation expenses.....	29.8	30.7
General expenses.....	2.2	2.6
Total expenses.....	63.8	62.7

Maintenance of equipment in 1913 cost \$1,595,000, an increase over 1912 of \$403,000. There was spent \$2,254 for repairs per locomotive in 1913, as against \$1,844 in 1912; \$536 for repairs of passenger train cars, as against \$516 in 1912; and \$55 for repairs of freight train cars, as against \$35 in 1912. Four locomotives and 2,348 freight cars were retired during the year. This policy of retiring light equipment as rapidly as possible is presumably responsible for the heavy increases shown in cost of maintenance of equipment. The very heavy train load is at least presumptive evidence that the Hocking Valley power is kept in thoroughly good repair, and average car loading of 36.3 tons presumably indicates that the greater part of the light equipment has already been eliminated. The average tonnage capacity of all freight cars in service in 1913 was 40.4 tons, as against 38.1 tons in 1912. At the end of the year but 2.8 per cent. of the freight train and work car equipment was undergoing or awaiting heavy repairs. The company will receive early in the present fiscal year 1,000 additional gondola cars of 57 tons capacity.

During the year \$860,000 was spent for additions and betterments. Fifteen receiving tracks were built and a water station and treating plant was installed at Parsons yard near Columbus, Ohio. The company also has under construction a new coal track and terminal yard at Toledo. The coal handling facilities at Toledo are just about equal to the present demand on them. The new dock will increase the coal handling facilities to such an extent as to easily take care of the peak of the load for a number of years to come, even if the Hocking Valley shows larger gains in coal traffic than it has on an average in the previous eight or ten years. No capital securities were sold during the year and \$316,000 equipment trusts were retired. At the end of the year the company had on hand \$1,529,000 cash, with total working assets of \$2,787,000, no loans and bills payable, and working liabilities of \$1,846,000. The profit and loss surplus is carried on the balance sheet at \$9,152,000.

The following table shows the principal figures for operation in the fiscal year ended June 30, 1913, as compared with 1912:

	1913.	1912.
Average mileage operated.....	352	351
Freight revenue.....	\$6,365,735	\$5,958,009
Passenger revenue.....	929,991	874,596
Total operating revenues.....	7,817,644	7,303,679
Maint. of way and structures.....	781,109	853,403
Maint. of equipment.....	1,595,266	1,192,191
Traffic expenses.....	106,384	99,621
Transportation expenses.....	2,332,475	2,245,657
General expenses.....	168,609	188,170
Total operating expenses.....	4,983,843	4,579,042
Taxes.....	477,900	414,188
Operating income.....	2,355,901	2,310,449
Gross income.....	3,030,574	2,902,149
Net income.....	1,916,404	1,830,836
Dividends.....	1,264,943	770,000
Surplus.....	651,461	1,060,836

**NEW BOOKS.**

*Wright on Quantities.* By G. Alexander Wright. Size 6 in. x 9 in., 16 pages, paper cover. Published by the author, at 571 California street, San Francisco, Cal. Price, 50 cents.

Mr. Wright's discussion of methods of estimating the cost of building construction is a reprint of an address given before the General Contractors' Association at San Francisco on April 10, 1913. It is a plea for a better system of cost estimating, and includes references to the methods used in England and the modifications necessary to apply such methods in this country.

**Letters to the Editor.**

**A DEFLECTABLE HEADLIGHT.**

DENISON, Tex., May 17, 1913.

TO THE EDITOR OF THE RAILWAY AGE GAZETTE:

In reply to a letter from W. F. Schaphorst published in the *Railway Age Gazette* of February 28, in regard to a deflectable headlight, I would state that the Missouri, Kansas & Texas has had such a headlight in operation for some time. When the Railroad Commission of Texas ordered all roads in this State to provide high power headlights we had a great deal of trouble in erecting the electric headlight housings so that when the headlight was properly focused the beam of light would strike the rails on straight track. To overcome this difficulty I invented an adjustable sliding base on which is mounted the front of the reflector so that by a slight adjustment of the reflector the desired result is obtained. All locomotives on the M. K. & T. have this

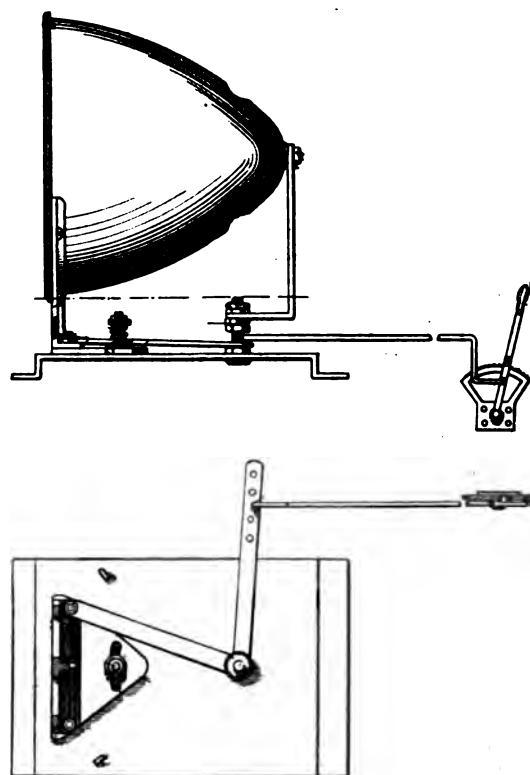

**Deflectable Reflector for Electric Headlights.**

adjustment. Later I improved this arrangement so that this adjustment may be controlled from the cab, thereby changing the ordinary electric headlight into a searchlight under the control of the engineer. This improvement consists of the addition of a bell crank attached to the front reflector support and pivoted on a stud placed directly under the carbon. To the other end of the bell crank is attached a rod which is fastened to a small lever in the cab. With this arrangement the effectiveness of the headlight is in no way impaired, as the deflector turns about its focal axis. Several of this style of deflector were placed in service on the M. K. & T. more than two years ago, and were very popular with the Texas engineers. The results obtained were very good and as far as I know gave no trouble, which I attribute to the simplicity of construction.

The advantages claimed for this headlight are as follows:

First: The headlight is under the control of the engineer at all times.

Second: An engineer can look around a curve at a level crossing when the locomotive is 500 or 1,000 ft. from the point of the curve to see if it is in the clear, or in entering yards on a



curve the engineer can see if the main line is clear of switch engines, box cars or cabooses.

Third: The very fact of sweeping the light around a curve (where there is a level crossing) would notify anybody well in advance that there was a locomotive coming.

Fourth: In clearing up wrecks, building bridges, driving piles, etc., the headlights can be diverted where they will do the most good.

Fifth: The headlight may be kept in the center of straight track.

Sixth: When two locomotives are approaching each other on double track, the engineers need not be blinded by the opposing lights, as one can divert his light to one side and the other on the opposite side as they pass.

Seventh: The only movable part is the reflector which is the lightest part; the arc lamp, wires, housing, etc., all remain stationary. The reflector turns around the carbon as a center; therefore the focus or clear spot of light is maintained in all positions.

Eighth: In case an engineer thinks he gets a phantom light from a switch stand he may divert the headlight off the switch stand and read the true signal.

This deflector is intended to be used by the engineer to examine dangerous spots on the road, such as level crossings on curves, curves going into yards, etc., also to keep his headlight true with straight track, and not to be used on every crook and turn of the track, which would be impracticable.

J. R. PRATT.

#### FREIGHT CAR EARNINGS.

PITTSBURGH, Pa., September 18, 1913.

TO THE EDITOR OF THE RAILWAY AGE GAZETTE:

I read with interest your claim, in the issue of the 5th instant, that if demurrage is regarded as a charge for the rendering of a service, \$1 per day is inadequate, and your implication that the charge should be \$2.50 per day, instead. If you are right, then the charge for a car which has been held for a year should be \$912.50, although the carrier would get the car back at the end of the year in as good condition, except for a little depreciation, as when it went to the industry, and would not, if the car lay idle at a point where it did not interfere with spotting, have been put to a dollar of expense outside of a little bookkeeping. If the car was worth \$700, a fair average value, when it went into the industry and the depreciation was \$100, which is a very liberal estimate; much too high, in fact, for an idle car, the return to the carrier would be over 115 per cent. per annum on the capital invested. Even at a dollar per day the return would be over 37 per cent., while at 45 cents per day, the amount the railroads charge each other, it would be over 9 per cent.

The fact is that average earnings of \$2.50 per freight car per day, on which your based your claim, are not the earnings of the cars alone but are the gross earnings per day of all the instrumentalities of freight transportation: locomotives, cars, roadway, bridges, tunnels, tracks, buildings, and the thousands of other things which directly or indirectly contribute to the transportation of freight, expressed in terms of cars. These earnings might just as correctly be expressed in other terms, such as earnings per mile, earnings per locomotive, earnings per railroad spike, or per any of the units of transportation between which and the gross earnings it is desired to indicate the relationship; but when so expressed the result is not the earnings of a mile of track, the earnings of a locomotive, or the earnings of a railroad spike. The relationship in different cases of the gross earnings to the number of cars involved varies greatly with the kinds and conditions of service, and for any given case can only be approximated by an intelligent study of the conditions in place of a sweeping generalization.

HENRY S. PRICHARD.

[Our correspondent has, possibly unwittingly, fully answered his own query. It is perfectly true that \$2.50 per freight car

per day represents the earning of a freight car with the use of its share of the rest of the plant, but the rest of the plant is no more necessary to the freight car earnings than are the freight cars to the rest of the plant. In other words, when a shipper ties up a freight car he ties up the use which that car might make of the entire plant. A mile of track at the end of a branch line might cost ten to twenty times as much as a freight car, but the loss of its use for a certain length of time to the company might not amount to by any means as much as would the loss of the use of a freight car.—EDITOR.]

#### GIVING AGENTS DETAILED INFORMATION ABOUT FREIGHT CARS.

WHITE PLAINS, N. Y., October 6, 1913.

TO THE EDITOR OF THE RAILWAY AGE GAZETTE:

In your issue of October 3, General Agent Hale asks that some of the men who are closer to the work of getting more movement of freight cars, give him something on the question.

It is a fact that the "men on the road" can and do accomplish a great deal toward the prompt movement of either loaded or empty freight cars, and it has been my experience that their efforts can be greatly facilitated by the one who is handling the car situation in the division office. In this office the despatchers do this work, and the following method has kept almost every car moving under the proper load, or moving to a point where it will be loaded in the direction of home.

I believe that one of the most useful bits of knowledge the car distributor can have is a thorough knowledge of the commodities received and despatched from the stations on his division, and exactly what kind of car is most suitable for both. With this foundation, take the car orders as early as possible, so as to get rid of surplus cars and fill other orders by the first train. With a little coaching I have found that nearly all agents will get enough information from the shippers to enable them to order cars of the correct size, capacity and condition; and the coaching can readily be accomplished by mailing the previous month's *Equipment Register* or *Line Clearance* to one agent or another as results warrant.

It is the smaller stations and the outlying spurs which need daily attention from the agent, and he will give this if he is reasonably sure that the cars on his tracks are being watched for use at other points. The larger yards seem to take care of themselves, to a certain extent, because cars must be moved out to make room for those coming in. A few cars may be overlooked on some isolated track, or blocked behind some cripples, but the trainmaster seldom overlooks them. A couple of cars moved promptly from each of the smaller stations, either loaded or for loading, will soon make the general result felt on the entire system.

W. E. BROWN,

Despatcher, New York Central & Hudson River.

RAILWAY FROM MADRID TO SEVILLE TO BE SHORTENED.—The growing necessity of shortening the route between Madrid, Spain, and Seville, has taken form in a government decree which authorized the minister of public works at Madrid to invite tenders for construction of a 75-mile railway from Puertollano to Cordoba. The government offers to assist in the work by granting a subsidy of \$10,800, and by a returnable loan of \$1,400 for each mile of line constructed. The builders are to reimburse the government for the total amount of the returnable loan in 20 fixed instalments, of which the first payment will be due two years after the completion of the entire line, the second payment the year following this, and so on. The successful bidder for this contract must make a deposit equivalent to 1 per cent. of the tender and plan approved. The plan to be preferred will unite with the most favorable technical conditions of construction the most direct route and the greatest possibilities for speed. In case no tender is accepted, government engineers will draw up specifications for the construction of the railway.

# THE STANDARD LOCOMOTIVE STOKER.

**Absence of Apparatus in the Cab and Noiseless Operation  
Are Prominent Features of This New Locomotive Stoker.**

Continuous 100 per cent. service from the day it was first put in operation over three months ago, is the record that has been made by the Standard locomotive stoker on a large consolidation locomotive on the New York Central. During the last two months this locomotive has been in regular road service, taking its turn with the others in its class. In this time it has made over 6,000 miles with full tonnage trains. An inspector has been on the locomotive at all times

of the locomotive itself that has been caused by the application of the stoker, has been the enlargement of the nozzle from  $4\frac{7}{8}$  in. to  $5\frac{1}{8}$  in.

All of this indicates a most remarkable success for the first application of a new locomotive stoker. During the first month's work the locomotive was kept in pusher service and several minor troubles occurred which were promptly corrected; and since the locomotive has been in road service



**Class G 6 F Consolidation Locomotive, New York Central, Fitted with a Standard Stoker.**

and readings of the steam pressure were recorded every five minutes. The average pressure for the whole period is nearly 198 lbs., with the pops set at 200 lbs. No test or record has been made of the coal consumption, but observation indicates that the stoker will consume from one and one-half to two tons less coal over the division than is used in hand firing. The engines burn about 28 tons when hand fired. The average speed of the train is practically the same as when fired by hand. The only alteration in the adjustment

practically no difficulties of importance have arisen in connection with the stoker's operation or maintenance.

A Standard stoker of this type was on exhibition at the Atlantic City convention last June and a brief description of it appeared in the June 14 issue of the *Daily Railway Age Gazette*. Since that time some changes have been made, particularly in connection with the part of the stoker that projects above the grate on the interior of the firebox. This section is now surrounded by a sloping conical-shaped grate

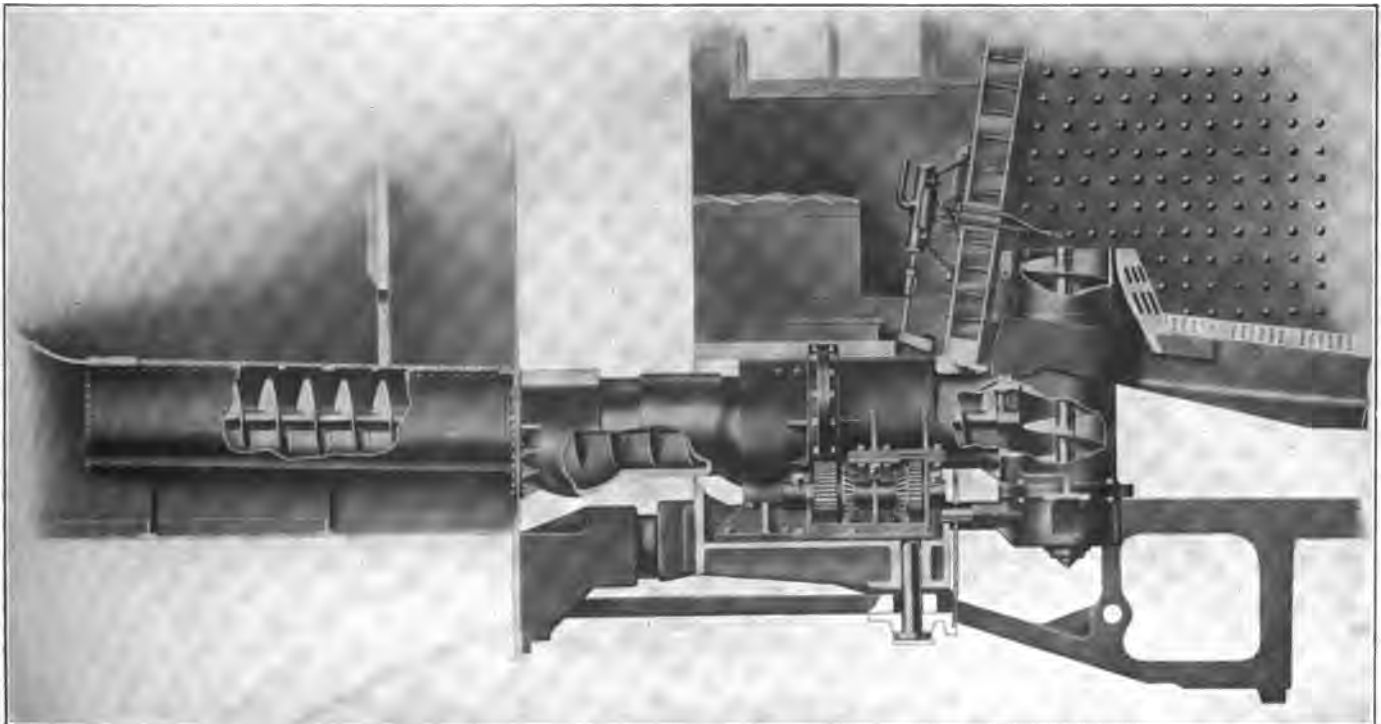

**The Standard Stoker; Showing Arrangement of Conveyor, Jets and Grates.**

which reaches to the top of the discharge pipe and insures it against overheating. Changes have also been made in the arrangement of the tender, although the new tender had not yet been put in service.

This stoker is of the overfeed or scatter type and employs a screw conveyor for carrying the coal from the tender to a point under the back mud ring, and below the level of the cab deck. This conveyor discharges to and feeds a vertical screw conveyor which carries the coal upward and discharges it at a point about 12 in. above the level of the grate, midway of the width of the firebox and close against the back head. Intermittent steam jets are used for distributing from this point to the various parts of the firebox.

A small two-cylinder vertical reciprocating engine, secured to the locomotive frame under the cab on the left side, drives the stoker. The shaft of this engine carries a heavy flywheel and a worm which meshes with the gear secured to the end of the horizontal shaft extending across the frame under the cab.

a slip joint at one end of the intermediate connection, no binding or unusual stress will be put on any part. Experience has shown that this construction works perfectly in every particular. The coal passes freely and all of the joints operate with ease.

The vertical screw conveyor is carried in a cast iron casing that is supported from the engine frame and from the mud ring and projects about 12 in. above the level of the grate. The shaft has a ball thrust bearing at the bottom and is arranged for complete lubrication at that point. For the protection of the upper end of this casing a specially shaped grate has been designed which includes the top ring of the casing and slopes diagonally downward on either side and in front in a conical shape, allowing the air to circulate freely around the upper end of the casing and keep it cool. Provision is also made for the admission of steam over the top of casing by a special jet, controlled from the cab, for keeping the conveyor cool when the locomotive has been standing for some length of time.

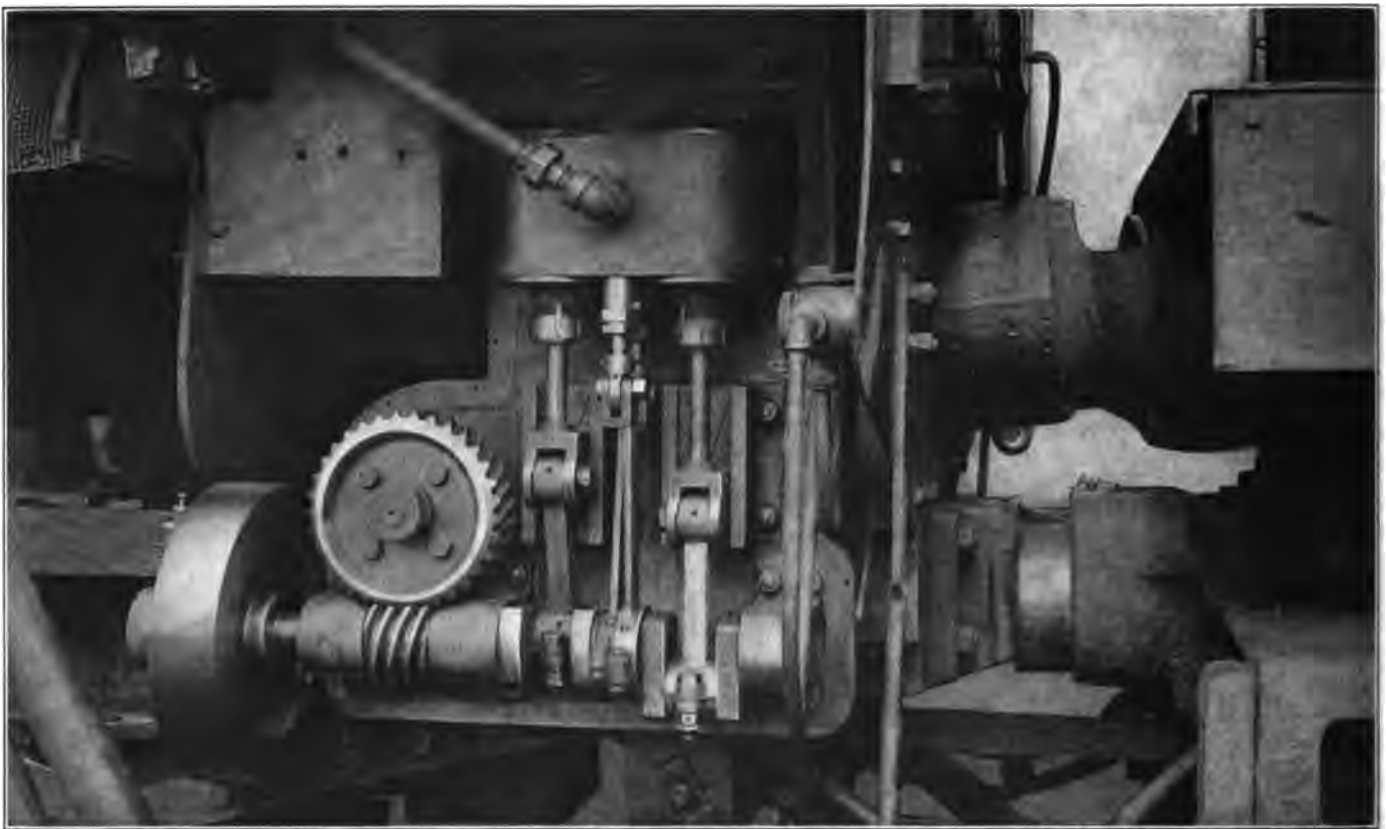

The Small Engine on the Left Side Operates the Stoker Conveyor and the Jet Control Valve.

This horizontal shaft carries a bevel gear on its other end which meshes with two bevel gears, one of which drives the horizontal conveyor and the other the vertical conveyor. All of these gears are enclosed and thoroughly lubricated. The horizontal conveyor consists of three parts connected by universal joints. The forward section is in a trough rigidly fastened to the foot plate of the locomotive and to the vertical conveyor casing. The second part is enclosed in a ball joint section of the trough which is arranged in two parts, having a slip joint between them and a ball joint on one end of each. This arrangement is clearly shown in the illustration. The third section is in a trough under the tender deck which is open at the top except for a wrought iron grating with openings six inches square, which in turn is covered by short sections of solid plate that can be moved to allow the entrance of the coal. It will be seen that this arrangement allows perfect flexibility between the locomotive and the tender and by using the two universal joints in the conveyor shaft, combined with a square section forming

The only part of the apparatus that is in the cab is a jet controlling valve which occupies a vertical position against the back head and between the fire doors, as is shown in the illustration. This valve has a reciprocating motion obtained from an eccentric on the main horizontal shaft. From it are carried the four  $\frac{3}{4}$ -in. pipes leading to the distributing jets. These pass through an opening in the back head and terminate just back of the center of the vertical conveyor. Each of them carries a nozzle pointed in different directions and one has two side openings for projecting the coal directly into the back corners. Each of these pipes is provided with a globe valve on the outside of the boiler, by which the pressure in it can be controlled independently. The jet distributing valve opens and closes the ports leading to these various pipes intermittently. As each is opened it projects a small amount of coal in a fan-shaped form over the section of the firebox toward which it is directed.

In the cab there is also located the control valve for the speed of the conveyor engine, the valve in the steam pipe leading to

the jet distributing valve and a gage on each of these lines, as well as the lubricator for the small engine.

In the operation of the stoker the amount of coal delivered to the firebox is controlled by the speed at which the stoker engine is operated, which in turn depends on the amount of steam pressure it is given. The distribution is controlled by an adjustment of the amount of pressure and the direction of each of the nozzles and this, when once properly set, seldom needs alteration. Close watch can be kept of the condition of the fire, since the fire doors are entirely unobstructed, and if it is found necessary, the rake can be introduced to level off the fire. Openings are provided in the cab deck through which any of the operating parts of the stoker can be reached from above. All bearings can be lubricated in this way and immediate attention given to any part that causes trouble.

On a recent trip which the writer made to observe the operation of this stoker the locomotive left the East Buffalo yards with a train of somewhat over 3,000 tons, in 71 cars. An average speed of approximately 20 miles per hour was maintained with this load. The coal used was of good quality and at no time was there any difficulty in maintaining full steam pressure. The amount of smoke made was approximately the same as would occur with the best skilled hand firing. At no time was there heavy, dense, black smoke and the color which would cor-

that the machine was actually in operation. The condition of the fire at all times was under full control of the fireman and the only occasions when it was necessary to use the rake were due to an unwise change in one of the distributing valves, which threw more coal to certain points than was actually necessary. When properly adjusted, the fire was maintained in a level condition.

The locomotive to which this stoker is applied has the follow-



View of the Tender Showing the Location of the Conveyor.

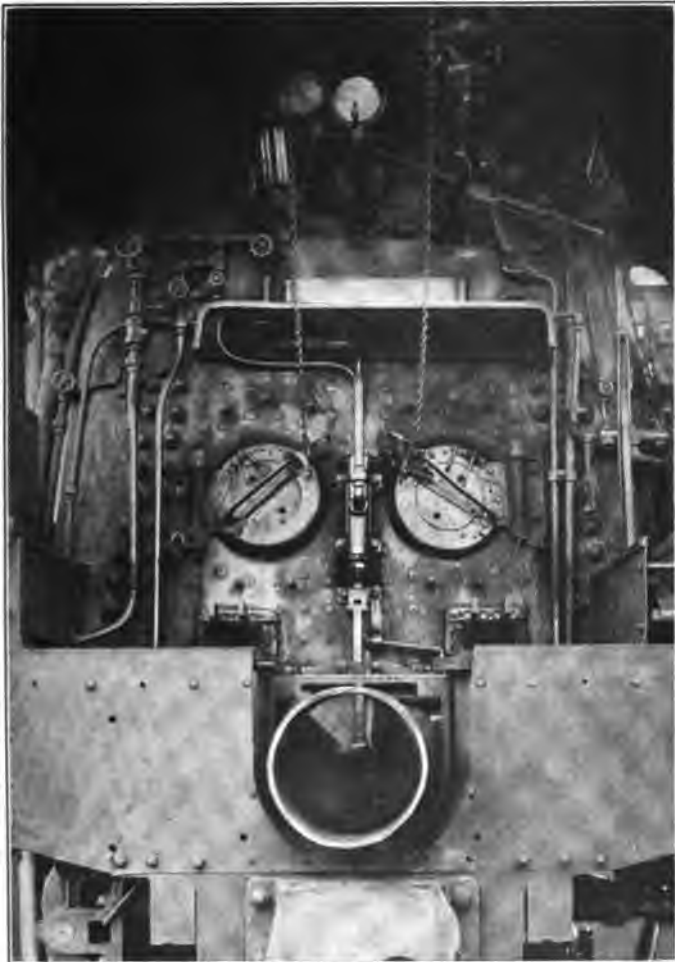

View in the Cab of a Locomotive Fitted with a Standard Stoker.

ing dimensions. It is provided with a brick arch but has no superheater.

Cylinders, diameter and stroke.....	23 in. x 32 in.
Diameter of driving wheels.....	63 in.
Steam pressure .....	200 lbs.
Tractive effort .....	47,200 lbs.
Diameter boiler, front end.....	80 in.
No. and diameter of tubes.....	444, 2 in.
Length of tubes.....	15 ft. 1/2 in.
Heating surface, tubes.....	3,497 sq. ft.
Heating surface, firebox.....	230 sq. ft.
Heating surface, total.....	3,727 sq. ft.
Grate area .....	56.5 sq. ft.
Weight on drivers.....	211,000 lbs.
Total weight, locomotive.....	236,000 lbs.
Tender, coal capacity.....	12 tons.
Tender, water capacity.....	7,500 gals.

The Standard stoker is manufactured by the Standard Stoker Company, Grand Central Terminal, New York City.

NEW EXTENSION FOR SOUTH AFRICA.—The railway extension from Caledon towards Kykoedy is now in operation as far as the farm Rietkuil. The farmers are already using the line for marketing their grain, large quantities of which have already been stored.

SEVILLE-MALAGA RAILWAY, SPAIN.—There is more than a rumor of the projected construction of a railway direct between Seville and Malaga, which would pass for a long distance through hitherto rather inaccessible country, via Moron and across the Seville-Algeciras railway at a point probably not far from Ronda. Construction of such a railway would greatly facilitate travel between Malaga and Seville, a journey now occupying almost eight hours by the fastest train. It would further tend to promote intercourse between the two cities and sections of country now without easy communication. Resulting increase in travel and in shipment of merchandise along the proposed line will prove the clearest endorsement of its advantages.

respond to No. 3 on the Ringleman chart was seen only occasionally. The amount of cinders discharged was remarkably small, in fact, it was with difficulty that it could be discovered that any were being thrown out of the stack. With the fire-door closed there was practically no noise at all from the stoker, in fact, it was necessary to watch a moving part to be assured

## HOW THE RAILWAYS HAVE FARED SINCE 1902.

By S. W. DUNNING.

The full Interstate Commerce Commission statistics for the railways of the United States have not yet been published for 1910-11 and 1911-12, but short abstracts of some of the principal data for both of these years have been given out, and by the help of these it is possible to inquire into the general course of traffic, earnings, and the progress of efficiency as shown by the proportion of employees to traffic, gross earnings and profits for the eleven years ending with June, 1912. From 1902 to 1907 there was great activity and great prosperity in railway business. But 1907 was the culminating year, and for the succeeding years the contrast is striking, as the following will show.

First, as to the course of traffic:

From 1902 to 1907 freight traffic increased 50 per cent. (from 157,289 to 236,601 millions of ton-miles), and passenger traffic increased 40½ per cent. (from 19,690 to 27,719 millions of passenger-miles). In very few countries of the world is the gross amount of freight traffic so great as the mere growth of ours for this short period of five years.

Now from 1907 to 1912, an equal period, the growth was 11 per cent. in freight and 19 per cent. in passenger traffic. Let us put the amounts and percentages of growth side by side.

	Growth in millions of		Percentages of growth	
	Ton-miles.	Passenger-miles.	Freight	Passenger.
1902 to 1907.....	79,312	8,029	50	40½
1907 to 1912.....	26,355	5,316	11	19

Thus in the earlier period the increase in traffic was *three times as great* in freight as in the later one, and *one-half greater* in passengers.

This is a tremendous change in the rate of growth. Even in the later period it was somewhat greater than the growth of population, and it would be considered fair progress in most countries; but so great a change in the rate of growth gave a shock to the industrial life of the country from which it is now only beginning to recover.

Naturally, between 1902 and 1907, while traffic was growing by leaps and bounds, the railways were compelled to make extraordinary efforts and invest extraordinary sums in order to provide facilities to meet the demands upon them; and everywhere railway managers were using their wits to devise the costly permanent works which would enable them in future years to carry the traffic which was growing at so rapid a rate. Additions to rolling stock and many improvements could be made year by year and were made during the five years of rapid growth. But the more extensive permanent works were only begun then; they have been executed and paid for chiefly since 1907, at a time when traffic had ceased to grow rapidly. Eminent instances are the New York terminals of the Pennsylvania and the New York Central.

The returns of capital invested were first made in the present form in 1907, and comparisons with 1902 have comparatively little value. The additions then were enormous, but greater nominally than really. From 1907 to 1912 the increase was very nearly \$2,500,000,000, or 18½ per cent.

Meanwhile, the increase in mileage (the mileage reporting operations) was 12¼ per cent. from 1902 to 1907, and 5½ per cent. from 1907 to 1912. New roads, however, absorb but a small part of the additions to railway capital in these days: it is the improvement of the old ones which swallows the money.

Naturally, the great increase in traffic from 1902 to 1907 made necessary an increase of the army of employees. The number employed increased 40½ per cent., from 1,189,315 to 1,672,074. The last year of this period the number employed on new construction was unusually great. The whole period was one of the substitution of heavy for lighter locomotives and of increasing trainloads; and the efficiency of the men, or, in other words, the economy as shown by the amount of transportation per employee, is not fully shown by taking the numbers for that year.

The next year (1907-8) this number was reduced by 213,830, or more than one-eighth. From this latter year to 1912 the increase in the number of employees was more than 18 per cent.

Now in 1907 the number of passenger-miles per man employed was the same as in 1902; the number of ton-miles, 7 per cent. greater. With 40½ per cent. more men the railways managed 40½ per cent. more passenger traffic and 50 per cent. more freight traffic. But in 1912, 18 per cent. more employees were required to handle 13½ per cent. more passenger and 20 per cent. more freight traffic than in 1908—the latter being taken instead of 1907, because of the abnormally large force engaged in new construction in the latter year.

The greater efficiency of the force employed was, of course, due to the improvements made; and the greater efficiency in the later than in the earlier period, to the fact that many improvements begun in the earlier were not completed till the later period.

The effectiveness of the employees in transportation, however, may be a very different thing from their effectiveness in producing earnings and profits. Below is a comparison of gross and net earnings per employee in the three years, as follows:

	1901-2.	1906-7.	1911-12.
Gross .....	\$1,452	\$1,548	\$1,664
Net .....	513	503	445

Thus the gross earnings of the railways per man employed in 1912 were 14½ per cent. greater than in 1902 and 7½ per cent. greater than in 1907; but their *net* earnings in 1912 were 13 per cent. *less* than in 1902 and 11½ per cent. *less* than in 1907.

These are figures which are worth pondering over. In them railway proprietors, managers and employees, and, not least, legislators, may find food for reflection. They cover two considerable periods: one of extraordinary activity, and another of sudden and great decline followed by comparatively slow growth in business and by a more rapid increase in the cost of doing it.

ITALIAN PASSENGER TRAFFIC.—A recent article in the *Journal des Transports* on the operating results of the Italian State Railways gives some interesting particulars regarding the nature of the passenger business. Compared with the inhabitants of other European countries, the Italians do not as yet seem to have developed the "travel habit" to any very marked extent. According to a series of comparative statistics compiled some years ago, the average number of railway journeys made annually in Italy was only 1.71 per head of the population. This compares with 22.82 in the United Kingdom, 14.26 in Belgium, 12.59 in Switzerland, 9.78 in Germany, 7.96 in France, and 3.55 in Austria. Not only is the average number of journeys small, but the statistics also show that travel is, for the greater part, of the short-distance order, 70 per cent. of the total number of passengers traveling less than 16 miles. This condition is not only disadvantageous as regards railway revenue, but from the economic and social standpoint it is in the highest degree desirable to stimulate the growth of economic relations between the north and south of the country. Politically, this is also of the greatest importance, since the old jealousy between north and south is still far from being extinct, and its embers are from time to time fanned into flame. The commercial and industrial centers being in the north, while the south is almost exclusively given up to agriculture, this antagonism is likely to persist so long as there is no free communication between the two parts of the country. Since the end of 1906 the Railways Administration has developed a policy of stimulating passenger traffic. This has taken the form of establishing a diminishing scale of fares, in which the charges per kilometer are progressively lowered after 100 miles, and of making great increases in the train service. The latter is, in fact, said to be often considerably in excess of actual requirements, which, as in the case of the French state railways, is one of the causes of the constant increase in expenditure. Still, if the Italian railway authorities believe that traffic facilities increase traffic, they have a good deal of favorable precedent on their side.

# CANADIAN NORTHERN MONTREAL TERMINAL

Driving a Tunnel 3.25 Miles Long Under Mount Royal to Reach New Passenger Station in Business District of City.

In building its new transcontinental line, the Canadian Northern was confronted with few engineering problems more difficult than that of securing a satisfactory freight and passenger terminal in the city of Montreal. The location of the city on the lower slopes of Mount Royal, a long ridge about 800 ft. high on an island in the St. Lawrence river, makes any railway approach to the heart of the city difficult, and the fact that the

## LOCATION OF NEW ENTRANCE.

As the Canadian Pacific's line to Ottawa occupies the south bank of the Ottawa river west of Vaudreuil and the Canadian Northern owned a bridge over this river at Hawkesbury, the logical route seemed to be on the north shore of the Ottawa river, making it necessary to cross the Back river, which adjoins the island of Montreal on the north, in order to reach the city. Having crossed to the island the best connection with the existing line, which entered the east end of the city, was secured by skirting the back of the mountain and crossing the ridge at a low elevation with grades considerably lower than the other roads have. This enabled the line to reach the freight yard at Maissonneuve and the harbor commissioners' transfer tracks very easily, providing a good freight terminal, but this had little relation to a satisfactory method of handling passenger traffic.

There are at present four passenger terminals in Montreal. The Grand Trunk Bonaventure station is located in the lower part of the city, being used by all Grand Trunk trains, as well as by those of the Central Vermont, the Delaware & Hudson, the Intercolonial and the Quebec, Montreal & Southern. This station is well located for the business section but is somewhat removed from the residential and shopping districts, and on account of the rather shabby surroundings, is not as popular with passengers taking early morning or late night trains as the Windsor station of the Canadian Pacific, which is not far away, but is on a higher level and is close to the principal hotels and shopping district. The Windsor station has a very attractive entrance from Dominion square, the principal park in the business section. This station is used by all Canadian Pacific trains east and west, except those which serve the province of Quebec exclusively. It is also used by the St. Lawrence & Adirondack and the Rutland divisions of the New York Central. The Quebec trains of the Canadian Pacific enter the Place Viger station, which is also in the lower portion of the city, but is far east in the French quarter. The present station of the Canadian Northern is on Moreau street, which is still further east and is altogether inadequate. All of these stations are essentially dead end, as through passengers on the Grand Trunk are carried

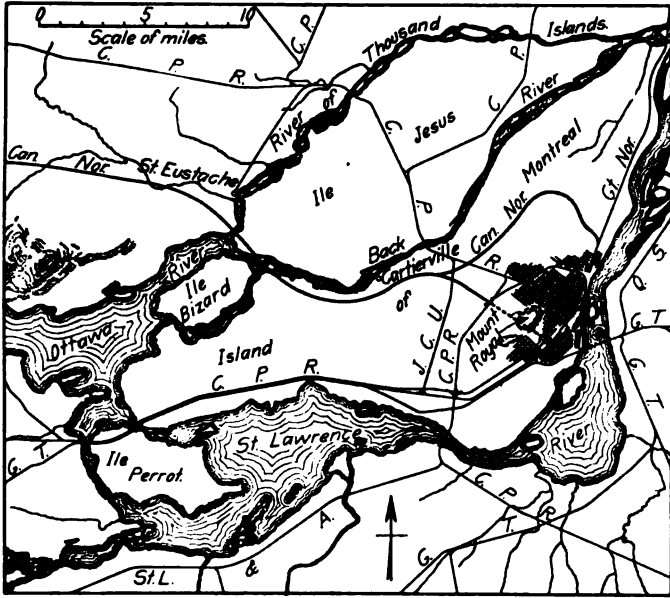

Fig. 1—Montreal and Vicinity, Showing Entrance of New Canadian Northern Line.

Canadian Pacific and the Grand Trunk were already located along the river front, the easiest approach, and owned terminals near the center of the city, greatly complicated the problem for the Canadian Northern. The new line could not parallel either of the old ones, as such a route could only have been built at a high cost and, when completed, would have been productive of little or no traffic for a considerable distance from the city.

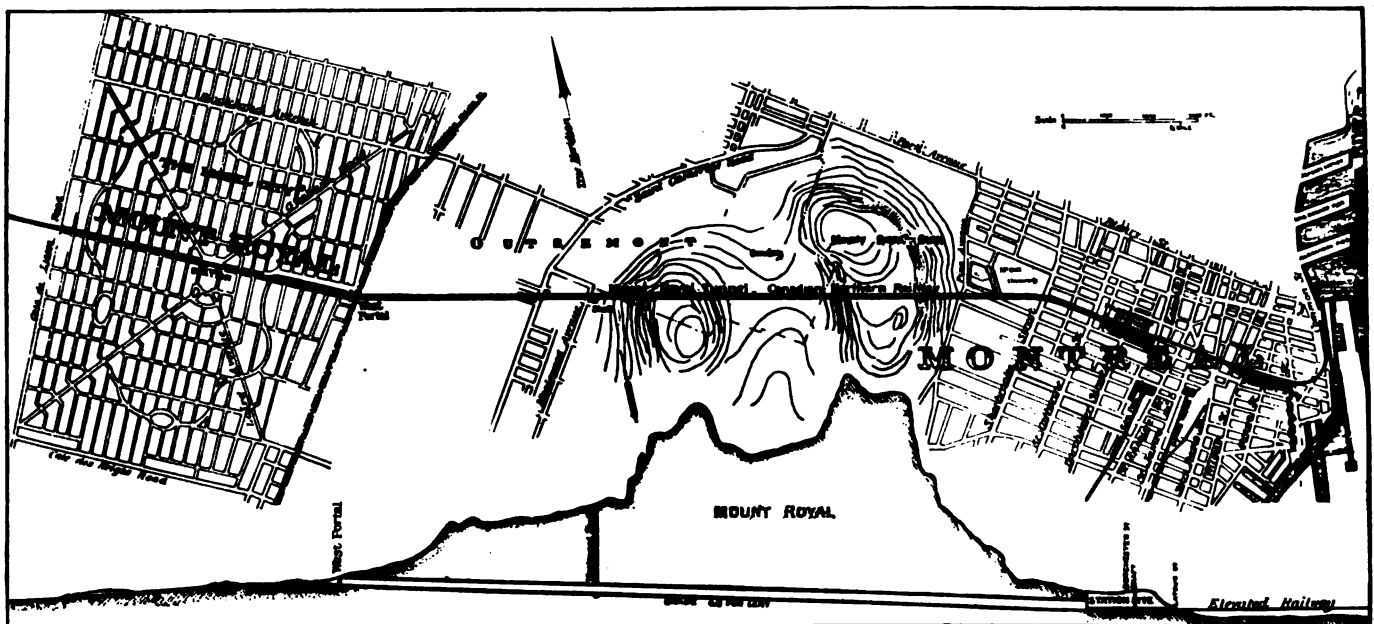

Fig. 2—Plan and Profile of the Mount Royal Tunnel

twice over the two miles of line from the terminal station to St. Henry, and on the Canadian Pacific over the four miles or more between the station and Montreal Junction.

The location, therefore, of a passenger station which by its proximity to the shopping and business districts could compete with the two existing stations and which could be made a part of a through terminal project, was indeed difficult. Having located the freight line on the other side of the mountain from the city, the only logical entrance for passenger traffic was to tunnel under the mountain. On account of the enormous cost of such a tunnel, this plan was not considered feasible for a long time and was only made practicable in the end by the decision to develop the territory north and west of the mountain for suburban purposes.

The original city of Montreal occupied a strip of low flat land about a half mile wide along the St. Lawrence river. As the city grew, it expanded back from the river until it occupied another flat or terrace extending another half mile toward the mountain. This level, which was originally the residential district, is now occupied by the shopping, theater and hotel districts, and the residences are rapidly being forced out. Some of the more wealthy inhabitants of the city have moved higher up on the mountain slope, but the principal growth has been along the river and around the two ends of the mountain. The development of the north and west slope of Mount Royal, which is well adapted to building purposes, has been made impractical by the length of time required to reach the business district by existing means of surface transportation. In anticipation of the development which will probably occur back of the mountain after the completion of the new tunnel, making an entrance to the business district easy, the Canadian Northern,



Fig. 3—Crusher Plant and Tipple at West Portal.

through a subsidiary company, bought large holdings of land in the most favorable locations for suburban development. It is expected that the increased value of this land will be sufficient to pay for the entire terminal development in the city.

#### STATION AND TERMINAL IMPROVEMENTS.

The location of the tunnel was governed in large measure by the location of the passenger station which is to be at the south portal, and in order to give the new station any advantage over the existing stations of the Canadian Pacific and the Grand Trunk, only a comparatively small area could be considered. Within this area the presence of a number of large buildings of permanent character, still further limited the choice and the

existence of a large unbroken block of land adjacent to a block covered almost entirely by second rate and old buildings, governed the final decision, which located the station between Mansfield and St. Monique streets and Cathcart and Lagauchetièrè streets.

The station will be on a terrace level about 50 ft. below Dorchester street. The elevation of the tracks will be such that the express and commuter traffic will be automatically separated. Carriages can drive directly on to the bridge level where bag-

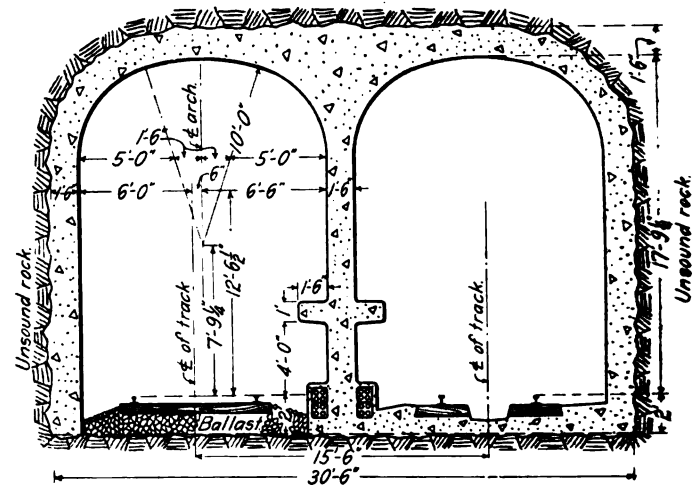

Fig. 4—Typical Sections of Concrete Tunnel Lining.

gage facilities will be provided, and foot passengers will be able to reach the platforms by easy ramps, stairs and elevators, from either above or below.

The new line will connect with the freight line a mile or more east of Cartierville, where division shops will be located, the north tunnel portal being just west of the Outremont yards of the Canadian Pacific. The approach to the portal is on a very flat grade with a descending grade in the tunnel of .60 per cent. The tunnel is 3.25 miles long.

The line will leave the tunnel at Lagauchetièrè street and will cross the lower portion of the city on an elevated structure, the plans for which are not yet fully perfected. By this arrangement the company will be in position to connect with any new bridge which may be built over the St. Lawrence, which must of necessity be located above Ste. Helens island to secure a satisfactory crossing of the river. A freight station and yard are also planned along this line, although the details of these improvements have not yet been decided on. Suburban stations will be located at the north tunnel portal and at other points where the traffic may demand, and an electrical transfer yard will be located at or near the division terminal at Cartierville.

The entire terminal will be electrified, although plans for this are still incomplete. Owing to the climatic conditions outside the tunnel, it is improbable that a third rail will be used on the ground, which will probably force the adoption of some form of trolley. This means high voltage, either direct or alternating current. Great strides have been and are now being made in high voltage, direct current railway work and, until very careful and exhaustive studies have been completed, no decision can be made. This is important in the final design of tunnel cross sections, as the amount of head room for 10,000 volts alternating is quite different from that required for 1,500 volts direct current.

#### TUNNEL CONSTRUCTION.

Mount Royal is a volcanic intrusion of igneous rock, principally Essexite, forced upward through Trenton limestone. Since the first principal eruption there have been many intrusions at various periods that have shattered both the limestone and the Essexite and filled the whole formation with dykes and

sheets of volcanic origin and very diversified character. In general the limestone is good tunneling rock, although where dykes are numerous it becomes somewhat difficult. The Essexite, although very hard, is a good tunneling rock and requires practically no timbering if the blasting is properly done. The most difficult ground encountered is a volcanic Breccia between the limestone and the main igneous intrusion. This conglomerate is so broken and blocky that both drilling and blasting are uncertain and difficult, and timbering is very generally required. The location of the tunnel as fixed by the portals causes the bore to pierce the heart of the mountain, consisting of an extremely hard igneous rock, but it is probable that no lining will be necessary in this material, the only masonry required in that portion being a dividing wall for the purpose of ventilation and safety. This hard rock could have been largely avoided by



Fig. 5—Heading Where Record Progress Was Made, Showing Water Connection to Drills.

making a detour of the main peak, but as this would have made a crooked alinement and would have passed under considerably more public and private property the direct line was considered economically better. In the Breccia limestone and bad ground where lining is necessary, the tunnel is being excavated for its full width and lined as a twin tunnel, thus making a separate and continuous tube for the traffic in each direction. A walkway will be provided on the center wall at about the level of the coach floors with occasional cross passages between the two tubes and a continuous refuse niche under the bench. Electric ducts will be carried along the base of the center walls and large refuges built occasionally in the outside walls for the accommodation of hand cars and repair outfits in times of emergency.

The minimum clearance has been limited to 16 ft. 6 in. above the rail, but the standard tunnel clearance will be about 17 ft. 9 in. The standard clearance in width is 6 ft. from the center line of track which may be slightly reduced near the bottom, as for instance, at station platforms.

The tunnel is being driven by the center bottom heading method. This heading is about 8 ft. high x 12 ft. wide, so that with jumbo timbers at the breakups, where the full-sized section is developed, there is still room for a double track (36 in. gage). Work was started at both ends of the tunnel and in both directions from a shaft near the north end. A horizontal bar is being used in the heading and in the breakup entries, with four drills on each bar. Columns are sometimes used in the headings, where emergency requires, and at the haunches of the breakups.

In the heading going east from the intermediate shaft a drill carriage is used, as the rock is very hard and the drilling equipment is correspondingly heavy. This carriage is run on the track track, and has a belt conveyor that drops the muck directly into the cars. It carries the drill bar on a 20 ft. cantilever arm that travels longitudinally through the drill carriage and also has a vertical and lateral adjustment for setting the bar in the heading. All movements are made by electric motors and controlled by one man. Thus the drills are never removed from the bar, no hose is disconnected in moving in and out except the main air and water hose which travel with the drill carriage. With this machine an average progress of 22 ft. per day is maintained in hard crystalline limestone cut by numerous dykes of extremely hard igneous rock. Without the drill carriage in this structure a progress of about 13 ft. per day was maintained, while in the clear crystalline limestone 18 ft. per day was maintained. In the 31 working days following May 1, a record of 26 ft. per day was made.

In the heading going west from Dorchester street the rock is not so hard as it is back of the mountain so that a lighter drilling equipment is required and no drill carriage is used. Near the Dorchester street shaft, which has thus far acted as the eastern portal, the heading was driven through a soft black limestone with occasional stretches of earth roof. As the rock cover increased, however, the rock became harder so that now the heading is in sound Trenton limestone, which is beginning to be slightly crystalline. There are occasional dikes, as on the other side of the mountain, but they are not so large or numerous.

At the breakups, jumbo timbers are placed in the heading so that traffic can be maintained and the upper portion of the tunnel stopped down and run directly into cars in the heading by gravity. As many of these breakups are opened as are found necessary to keep up with the heading progress.

Where soft ground is encountered, a cap and post system will probably be used, owing to the location of the rock surface; this running in general fairly near the roof line permits the full width timbering to be placed without shifting posts, which rests directly on the rock. As fast as the roof excavation can be carried on in this manner, the arches will be built, so that the roof will be absolutely protected. After the arches are in, the lower excavation will be removed and the arches underpinned, where necessary.

The drilling in limestone is carried on with Sullivan water drills, of which 33 are in service. These drills are operated at an air pressure of 100 lbs., and are provided with an improved method of introducing water in the drill hole to clear out the slush. A pressure of 50 to 100 lbs. per sq. in. is required for this work, the water supply being brought in under pressure from pumps and distributed to the drills by a manifold. The water used is only enough to make a heavy paste of the mud, as excess water is objectionable on account of its liability to get into the drill and make it difficult to lubricate. These drills are mounted on horizontal 11 ft. heading bars with a leg or support in the center to secure stiffness. Four drills



are used at once on each bar. In unusually hard rock three double screw mining columns are used instead of the bar. The average depth of holes is 5.5 ft., and the average speed per drill 16.5 ft.

The firing is done electrically, but an effort is being made to get some special time fuses with electric igniters, by which the cut may be fired electrically, at the same time igniting the time fuses of the relievers and line holes. This should give a better result than the ordinary time-fuse method, without its accompanying risk, and will relieve the men from the necessity of going back into the smoke to load the later rounds.

The muck cars are 3 ft. gage, very low and narrow. They are built with a 3 ft. wheel base, 18 in. wheels and springs on the axles. Both gasoline and storage battery electric locomotives are used. All of the tunnel muck is being crushed for concrete stone and ballast. The crushers are of the gyratory

The shops consist of a main blacksmith shop, equipped with an air hammer, shears, punches, drill sharpening machinery and the usual forges; machine shops equipped with large and small lathes, a shaper, radius drill, saws, pipe machines, emery and grind stones, etc.; carpenter shops, with band and circular saws; and drill repair and testing shops, as well as garage for the maintenance, storage and repair of automobiles and auto trucks.

From May 1, 810 ft. of 8 ft. x 12 ft. heading was driven in 31 working days. The average progress to date has been 400 ft. per month in each heading. The first heading was started July 8, 1912. Since that date one intermediate shaft 240 ft. deep and one portal shaft at the city end, 55 ft. deep, have been sunk, and over two miles of heading have been driven on the tunnel line.

H. K. Wicksteed, chief engineer of surveys for McKen-



Fig. 6—Break-up Showing Heading and Jumbo Timbers.

and roll hammered types, to give the desired grades, and both revolving and oscillating screens are used over the bins. The cages used at the shafts are of the counterbalanced automatic-dumping type, with electric hoists. These are designed for a capacity of about 800 cu. yds. per day each.

The plant for the Mt. Royal tunnel will be quite complete. The compressor plants at each end consist of one direct connected cross compound unit of 2,200 cu. ft. per minute capacity, driven by a synchronous motor, and three belt driven cross compound units of 1,100 cu. ft. per minute capacity, with induction motors. The motor is three phase, 62½ cycles at 2,200 volts. Pumps, drills and some small motors are run by air. Most of the power used, however, is electrical.

zie-Mann & Company, was in charge of the location of this terminal, and S. P. Brown is the managing engineer in charge of the construction of the tunnel. We are indebted to Mr. Wicksteed for the general information above, and to Mr. Brown for the details of the tunnel work.

RAILWAYS OF FORMOSA.—The government of Taiwan (Formosa) held a celebration in the capital city of Taihoku, August 3, 1913, in commemoration of the completion of 1,000 miles of steam railway in the island of Taiwan. Of this total mileage the government owns and operates 327 miles. The remainder is owned and operated by the modern sugar companies.

## THE CLAIM DEPARTMENT—AN ASSET.

BY L. MOORE,

Claim Agent, Chicago & Eastern Illinois.

Experience would seem to indicate that the efficient handling of personal injury claims, both of employees and those not in the employ of the company, as a controlling force in the successful operation of a railroad, is but little considered or understood. The claim department is encountered or brought to the personal observation of the average railroad executive only as a department of expenditure, and he will be nevertheless genuinely surprised when he comes in contact with the actual workings of the modern claim department to discover that it is a most valuable asset.

The old-time claim agent with his often dubious methods is now discredited by the majority of railroads. The personality of the average claim agent or adjuster is as immeasurably raised from that of the unfinished product of a quarter of a century ago as is the method by which he does business. The men who direct and control the policy of a railroad company in the adjustment of personal injury claims should be trained leaders of the new spirit of humanity, the spirit which recognizes that there is a large element of science even in the once decried occupation of adjusting personal injury claims. This recognition must come about because of the great changes made in the common law which have eliminated from consideration the old-time defenses of assumption of risk, fellow servant rule and contributory negligence; also the further fact that the passage of modern employers' liability laws and workmen's compensation acts, and in addition the tendency of juries to favor the claimant and the inclination of the courts to affirm such verdicts, have revolutionized the methods formerly employed in adjusting personal injury claims.

That there was any better method of settling claims than the old way, with its oftentimes shady details, its tricks and chicanery, was a subject of ridicule by many for years, but the astonishing results obtained by the alert and intelligent men of today, who bring to their work minds trained to regard their tasks in the light of an almost exact science have caused the claim departments to be placed on a higher plane than ever before and to make claim adjusting an interesting field for intelligent and efficient men of legal training.

The chief engineer in building his bridges, straightening the curves in the road, laying heavy rails and using rock ballast is not only considering the present, but he is building for posterity. The efficient manager of every department of a railroad company is planning his work for the future, and I know of no branch of railroading where this can be done with greater results to the company than through the medium of a right-minded claim agent, but, in the settling of claims the fixed purpose of saving a dollar regardless of consequences is too often false economy and too often obliterates from our vision the human side. Remember that the traveler who is injured will continue to use the railroad, his children and his children's children will some day be passengers, and the treatment the injured party receives—not so much the amount of money he is paid, but the establishment of a feeling of confidence, of a feeling the railroad company in making a settlement is actuated by a spirit of fairness—will in the long run redound not only to the honor and glory of the claim agent but to the popularity and profit of the railroad company by whom he is employed.

What a versatile man the claim agent must be; he is in the house where the shades are drawn, the spirit of gloom and desperation are around about, and one must listen to the grief-stricken woman who has been left alone because of a grade crossing accident whereby husband and son lost their lives. The poor woman embittered by her loss calls to heaven for vengeance upon the railroad company. Her reason is gone; money can not bring back the loved ones and, in her opinion,

the railroad company can offer no defense for the terrible catastrophe. In the first place there must be established a bond of genuine sympathy, then there must be sincerity and an earnestness of purpose and a true manifestation of helpfulness which will tend to bring about a feeling of confidence, and when you have gained the trust and confidence of the aggrieved party the battle is half won. The claim agent crosses the street and becomes engaged in an argument with a hard-headed old farmer as to the value of a Berkshire hog which has wandered on the right-of-way through a broken fence, and is killed. The claim man must be entirely familiar with hogology and able to quote the latest market prices on live and dead pork. Then there comes a claim to be adjusted for damage to pasture land by fire, which it is claimed was started by a spark falling from a passing locomotive. Following these comes a man who claims his land has been damaged by reason of cinders washing down from the right-of-way because the drain pipe is not of proper proportion to carry off the surface water in time of storms. To complete the day there comes a conference with an attorney as to whether the state compensation act or the federal employers' liability applies in the case of a foreign section laborer killed while on duty.

A successful claim agent must do the right thing at the right time and in the right way; he must work from reason rather than from rule. In these days of hysterical activity on the part of unscrupulous attorneys, the greatest duty a claim agent owes to the company and to society at large is to eliminate the "Ambulance chaser," and in so doing conduct a campaign of education, which has for its purpose the prevention of litigation where there are no grounds for an action at law, and to impress upon the community at large the ulterior motive which prompts the unscrupulous attorney to promise a verdict of impossible amounts, provided he can get 50 per cent. of the amount recovered. Sixty per cent. of the time of all our jury trial and first appeal courts is taken up in the consideration of negligence cases, a large majority of which have no merit and should never be brought into court. Actual figures show that of about six thousand suits in negligence, the average payment which the defendants were compelled to make by operation of law, was about three hundred dollars a case. Experience tells us that the average retainer fee that plaintiff's lawyer secures is almost 50 per cent. of the recovery. So that in the estimate given above the injured man in these cases did not get even the small average payment suggested but only about one-half of it. It may be said, without fear of contradiction, that in every case in which there is legal liability and the injuries are serious, all honorable effort is exhausted to make a reasonable compromise, and the railroads of the United States pay without suit many thousands of dollars in compensation.

The taxpayers in one of our larger cities, in the year 1908, paid over \$4,000,000 to maintain the judicial system and during this same period 40,000 business men were drawn for jury duty at an expense to the taxpayers of over \$415,000 in fees. It is estimated that the judicial institutions of the above-mentioned city cost the taxpayers not less than \$6,000,000 a year, and 60 per cent. of it is chargeable to the administration of the law in so-called negligence cases. A presiding justice of the appellate division of the supreme court of New York made the statement that about seventy-five per cent. of the time of the courts was taken up in the consideration of negligence cases, a large portion of which had absolutely no merit.

Who is responsible for this condition of affairs? It can be traced directly to the pernicious activity of the "Ambulance chaser" and his runners. When they hear of an accident they appear at the bedside of the afflicted; they succor him and his dependents and they subsidize his cause. While the claim department is conducting its investigation, wiring the numerous commissions that an accident has happened and filling up elaborate card indexes with data concerning the victim and his dependents, the redoubtable "Ambulance chaser" is on the job

with bread for the family and encouragement for the afflicted in an eloquent tale of what is going to happen as soon as the case is presented to the jury. They are willing to stake all their help and what little they have of reputation against a possible victory in court, obtained maybe, five years afterward. Do not carry away the idea that all lawyers representing plaintiffs in negligence cases are "Ambulance chasers." The contrary is the fact. The majority of plaintiffs' lawyers are honorable practitioners, with the result that the cases are settled and never get into court.

The claim man should with his advance information be able to get to the scene of an accident in advance of the "Ambulance chaser," and it is the writer's opinion that it is the paramount duty of the representatives of the claim department to point out to a prospective claimant the foolishness of litigation, the long delays incident thereto, the dreadful uncertainty of juries, and above all the utter folly of signing a contract with any attorney on a contingency basis because the lawyer has nothing to lose and everything to gain, at least until such time as an agreement cannot be reached between the claim agent and the injured party. Until the day arrives when our laws are changed, the claim man must continue to fight the battle against the unscrupulous lawyer along the lines indicated, and in such better and more effective ways as may occur to the creative brain of each claim man.

## THE COAL MINING ADJUNCTS OF RAILROADS.

By JOHN D. A. MORROW.\*

According to the decision of the United States supreme court a few years ago, the Hepburn law does not prohibit the ownership by railroads of the stock of coal mining companies. Several railways have made investments of that character, not merely for the sake of obtaining control of fuel supplies, but in some cases perhaps also with a view to an increase in the tonnage of coal transported. In the Census Bulletin on the Statistics of Coal Mines, issued recently, certain tables contain statistics relating to the mines in which railroads are thus interested. Security ownership of this kind is reported to the Interstate Commerce Commission and these reports were used to make the census classification of coal mines by which these statistics were obtained. Of course any mines controlled in ways not reported to the I. C. C. would not be included in the railroad group; furthermore the figures are for the year 1909 and since that time some changes may have taken place, but even so the figures are of interest and value in indicating the general conditions in respect to such properties.

Table 11 of the Census Bulletin shows that out of a total coal production of 458,000,000 tons in 1909 about 122,000,000 tons, or 26 per cent., were reported by mines more or less closely affiliated with railroads. This total was almost equally divided between anthracite and bituminous coal. Tables 23, 24 and 25 present detailed statistics of the Pennsylvania anthracite operators which were allied with the anthracite carrying roads, but the general facts in regard to these producers are well known and, beyond the brief statement that these companies reported more than 75 per cent. of all the anthracite produced and controlled nearly 85 per cent. of all the anthracite land reported, no additional discussion is necessary here. The bituminous mines which are connected with railways have not received so much attention, however, and accordingly a brief résumé of the more important statistics for these mines is given.

Table 45 of the Census Bulletin summarizes the principal returns obtained from a classification which gives separate figures for the bituminous coal mining adjuncts of railway companies, of iron and steel companies, and of other industrial companies. From this table it appears that there were 33 railroad systems

which were more or less directly interested in the operation of bituminous coal mines. The coal mining concerns of this class produced approximately 61,000,000 tons of bituminous coal, or nearly one-sixth of the total for the country. They controlled more than 1,500,000 acres of land, of course mostly coal bearing, or practically one-fifth of the 7,700,000 acres reported by all the bituminous operators in the United States. They operated 430 mines out of the total of 6,013, and gave employment to 94,000 wage earners out of the total of 570,000 accredited to the bituminous industry by the census.

As might be expected, more than 93 per cent. of the coal produced by these companies was consumed as fuel; the remainder, a little less than 3,700,000 tons, was coked at the mines, from which 2,400,000 tons of coke were obtained. The total value of this coke at the ovens, together with a small value of by-products, was \$5,300,000; while \$71,800,000 was the total value reported for the 61,000,000 tons of coal produced. However, the combined value of all products, coal, coke and coke by-products, is given by the Bulletin as \$74,000,000, but this result excludes the value of the 3,700,000 tons of coal coked, viz., \$2,300,000, and thus avoids duplicating values. On the other hand the total expense of producing the coal, coke and coke by-products was only \$65,600,000, likewise excluding the value of the coal coked at the mines. Hence the total value of the products of these companies shows a surplus over the total expenditures reported which amounts to more than \$8,000,000. In this connection it should be said that the total surplus for the entire industry was \$32,000,000. Accordingly, the mines affiliated with railroads, although producing only about 16 per cent. of the total output of bituminous coal and about 7 per cent. of the coke made at the mines, accounted for more than 25 per cent. of the total surplus. While the census data are not obtained for the purpose of ascertaining profits and do not show the precise amount of profit or loss, they are sufficient to warrant the conclusion in this case that the mines affiliated with railway companies made a better showing for the year than the average of other mines.

The figures also indicate that the operations in which railroads are interested are not small scale enterprises. Their average output per mine was more than 140,000 tons, while that of all other shipping mines was only 70,000 tons. From the standpoint of the operating organization the comparison is even more striking. In making this comparison several subsidiaries all controlled by the same parent company are not considered separately, but are combined and treated as one, e. g., in the case of a railroad with three coal mining adjuncts the owning railroad is considered as a single operator. The returns of all coal mining companies were similarly treated. On this basis it appears that the average output of bituminous coal per operator was 1,800,000 tons for the railroads, while for all other producers it was only 130,000 tons. Table 48 furnishes additional information on this subject. That table classifies these operating organizations according to the total value of products reported (again excluding the value of coal coked at the mines). This classification shows that 21 railroads were each interested in coal mining concerns whose aggregate value of product exceeded \$1,000,000; that 10 more were each affiliated with mines whose total value of output was between \$100,000 and \$1,000,000, and that the two remaining roads were each interested in properties with a value of product less than \$100,000. Accordingly, it appears from these figures that most railroads which have made investments in bituminous coal mining companies are, in this indirect manner, rather important producers.

PROPOSED NEW MOROCCAN RAILWAY.—An inspector-general of roads and bridges and an engineer have arrived at Casablanca with the object of studying the conditions incident to a projected railway between Casablanca, Fez, and Tangier. The line as proposed will run through Rabat, Souk-el-Arba, Lai Aito, and Mequinez. Work on the railway will be commenced in September, 1914, and it is hoped to complete the line in about two years.

\*Formerly special agent in charge of coal mining statistics, U. S. Bureau of the Census.

# FEATURES OF THE KALKA-SIMLA RAILWAY.

Heavy Protective Work Necessary on This Narrow Gage Line up the Himalayas Results in High Construction Cost.

By LEWIS R. FREEMAN.

It is a remarkable fact that, in spite of its having a gage of but 2 ft. 6 in., the 60-mile long Kalka-Simla railway which negotiates the Himalayan portion of the journey to the summer capital of India, has the highest average cost per mile of any road in India. There are doubtless other 60-mile stretches of line, such as that which includes the remarkable series of double-tracked switch-backs where the Great Indian Peninsular climbs the western Ghats from Bombay, or the piece of frontier line which the Indian government, regardless of expense, built when Baluchistan was threatened by the Afghans in the 70's, which have cost more than the Kalka-Simla narrow gage, but this has been compensated for by cheaper construction at other points, so that the averages of the complete systems fall far below that of the Himalayan line.

The average cost per mile of some of the prominent Indian

The looseness of the rock is the real source of the difficulty, for the rains are by no means as heavy as in the Darjeeling district. When thoroughly soaked this rock runs together and begins to slide like soft slush, and no amount of precautions have served to make the road immune from the resulting slips.

As Simla is the seat of government for all of India for six months of the year, for the province of the Punjab for the same period, and is also all-the-year-round headquarters of the Indian army, the service performed by the Kalka-Simla Railway is highly important. From 1850 to 1903 all the traffic between Simla and the plains was carried on over what is called the Hindustan-Tibet cart road. This was before the days of the auto truck, which has done so much to simplify the problem of transportation for the Insular government in maintaining its summer capital at Baguio, in the Philippines. The congestion

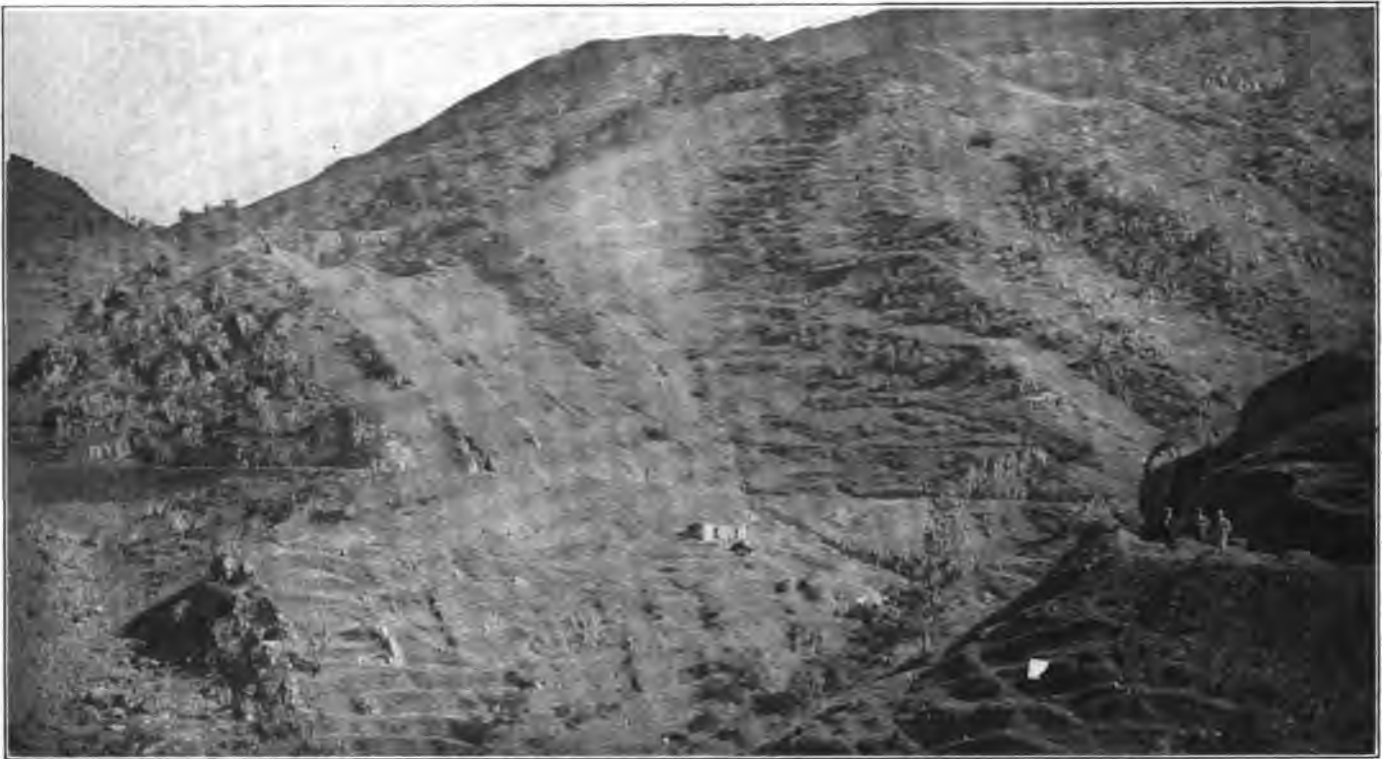

Loose Rock Formation Through Which the Kalka-Simla Railway Was Built.

railways is as follows: Eastern Bengal State, \$83,000; North-western State, \$70,000; Oudh and Rohilkand, \$43,000; Bengal-Nagpur, \$55,000; Bombay, Baroda and Central India, \$91,000; East Indian, \$88,000; Great Indian Peninsular, \$76,000. All of these lines are of 5 ft. 6 in. gage, and of modern construction. The Kalka-Simla line, with a gage of but 2 ft. 6 in., has already cost \$108,000 per mile, and contemplated improvements will doubtless considerably increase this figure.

The high cost of this line is due rather more to geological than topographical causes. It has to ascend but 5,500 ft. in 60 miles, while the Darjeeling line is compelled to negotiate 7,000 ft. in 45 miles, and while the necessity of maintaining a 3 per cent. grade entailed an exceedingly large amount of tunneling, cutting and filling, the greatest expenditure has gone into protective work to prevent the torrential monsoon rains from carrying away the loose shale formation over which the line is built.

of the cart road finally became so great that the construction of a railway became imperative to the continued existence of Simla as governmental headquarters. Work was commenced in 1899 and finished in 1903, the cost of the line ready for opening being \$5,000,000, or about \$83,000 per mile. Trouble from slides was encountered from the first day of construction and has continued down to the present time, with the result that capital expenditures for protective work have increased the cost of the line by \$1,500,000, or to a total of \$108,000 per mile.

Protective work is seen at every turn. The bottoms of the least depressions where water runs are lined with cement where practicable, and where the rock is too loose for that, sheets of corrugated iron are laid to keep the floods from washing away the loose formation. There are a number of tunnels which were run for no other reason than to take the track away from the menace of slides at exposed points, and there are places where

brick walls have been built on the open hillsides to stop the moving rock somewhat after the fashion of the snow-drift barriers on our northern railways. In spite of all these precautions, almost daily trouble with slides and washouts is encountered during the monsoon season, and it is estimated that anything



Difficult Tunnel Approach; Kalka-Simla Railway.

approaching complete immunity cannot be secured under an additional expenditure of \$25,000 per mile.

There are 103 tunnels in the 60 miles of the Kalka-Simla line, undoubtedly one of the highest averages for any similar length of track in the world. Most of these are short, but the Barogh, 3,752 ft. long, is next to the longest in India, the latter distinction belonging to the great two-mile tunnel on the Quetta branch of the Northwestern Railway.

The bridges have also been a considerable source of expense. They are mostly short, but of an unusual design, consisting of tiers of brick arches. The lack of a suitable stone close at hand compelled the use of brick, which, while expensive, will hardly prove very long-lived. If the road was being built today, these bridges would probably be built of concrete.

The roadbed is laid with 41-lb. rails on wooden ties, and is being renewed with 60-lb. rails. It is fenced with wire and ballasted with stone throughout. (The fencing, by the way, obviates the necessity of an amusing practice of the Darjeeling line which I have failed to mention: that of keeping a burning log of resinous wood attached to the smokestack, supplemented by a Hindu armed with a bucket of stones on the pilot, to frighten off stray bullocks and other wandering stock from the tracks.) Most of the curves are compound, the limiting radius being 120 ft.

The Simla line, which was built by the Delhi-Umballa-Kalka Company, was purchased by the Indian government in 1906, and has been operated by the latter, through the Northwestern State Railway ever since. The passenger fares approximate 10 cents a mile, first class; 5½ cents a mile, second class; and 1 5/6 cents a mile, third class. The traffic has been considerable, the gross earnings increased from \$255,000 in 1906, to \$343,000, in 1910. Maintenance has been extremely expensive, however, and the net earnings have been less for the last two or three years than in 1906-7. Special renewals in 1910 reduced the net earnings to \$12,000, or 0.18 per cent. on capital. Heavy interest and maintenance charges have been responsible for the fact that the loss to the state in operating the Kalka-Simla line has increased from \$60,000, in 1907, to \$190,000, in 1910.

RAILROAD CONSTRUCTION IN SOUTHERN INDIA.—It is proposed to construct an 80-mile railway, estimated to cost \$2,756,833, between Mangalore, an important port in the district of South Canara, southwest coast of India, and Ariskere, an interior town in the state of Mysore. This line will supply a great need of the agriculturists of western Mysore, as it will provide the only direct rail communication between that productive region and the Malabar coast. Construction of the new road is to be financed through co-operation of the Mysore government and the South Canara district board, together with subsidiary assistance by the central government of India. The project has the enthusiastic support of the United Planters Association of South India, and, as a survey has already been made of the route, it is anticipated that active construction work will not be long deferred.



Type of Bridge Construction; Kalka-Simla Railway.

## SOME ASPECTS OF RAILWAY REGULATION.\*

By FRANK J. LOESCH,

Local Attorney, Pennsylvania Lines.

The intelligent layman, not an expert in the intricacies of our dual form of government, would naturally infer that when Congress had placed railroads under national control as an agency of interstate commerce, and exercised such control by taking away from the railroads their power to make and maintain rates; by prescribing the character and extent of costly safety appliances; by fixing the railroad's liability to its employees injured in its service; by prescribing a method of keeping its accounts and forbidding any other method, and by a multitude of other regulations, expensive for the railroads to comply with, state control had been effectually displaced.

Not so, however. Upon the hand of the state has been placed the heavy hand of the nation, and so long as both hands do not cover the same regulated spot, both are effective—so long as state regulations are not a direct burden upon interstate commerce, they are valid. No matter how burdensome and costly to the railroad's interstate business compliance with a state statute or regulation may be, if its effect on interstate commerce is indirect, it is lawful. The decision in the Minnesota rate cases has settled the law accordingly. The Supreme Court says in effect that Congress may take such regulative control from the states as incident to its powers under the interstate commerce clause of the constitution; but until Congress does act, a state may make regulations governing local rates, and under the guise of police regulations may make destructive indirect inroads upon earnings from interstate traffic.

The practical application of that principle to a concrete case may be illustrated by the effect of one of the so-called full train crew laws. Such a law went into effect in New York state during this month. It compelled the employment of many hundreds of additional men unnecessary from the standpoint of the safety of the public, the railroads or the ordinary train crews. It was authoritatively stated that that law will cost the railroads of that state \$2,000,000 per annum, of which about one-half will fall on one railroad system. The local or intrastate traffic of that system most assuredly cannot carry that unprofitable charge. It must, therefore, be taken from the total earnings of the entire system, from interstate and international traffic. And though the effect may be to reduce the net income below a fair return on the capital of the system, yet under the principles laid down by the Supreme Court, there can be no relief for the railroad, because the effect of the operation of the full train crew law is an indirect and not a direct burden on interstate commerce.

If the Supreme Court adheres strictly to the principles laid down in the Minnesota rate cases, that it would never interfere with the operation of a state law in its effect upon railroad earnings, so long as it was not a direct burden upon interstate commerce, then, by the cumulative effect of state laws of a similar character, burdening the railroads with unnecessary employees, additions and equipment, any system operating over a number of states could be brought to bankruptcy without hope of relief from the courts.

That this peril is not a remote one we have yearly evidence of. President Darius Miller has publicly stated that in the past eight years the individual states have enacted no less than 1,800 laws for the regulation of railroads—those statutes pertaining to almost every detail of their operation, rate making and accounting.

Railway charters are usually granted only by a state. No railroad charter has any extra-territorial effect. Therefore, every railroad system running through or over more than one state has as many charters for as many railroads as there are states through which its main lines may run, and separate charters for all its other lines and feeders, while the bonds and stocks issued by it are more and more secured upon its entire system and upon the credit of that system. When the federal

power deals with the railroad company, it deals with it as an entire system, and takes no regard of the individual railroads chartered by the several states composing the system. This is markedly noticeable in the Hepburn act.

On the other hand, the state takes no control of and is not permitted to control the system of which the state railroad is only a part, nor of the securities which have been issued upon the entire system, nor how a particular statute or order of the commission may effect the system, but considers only the railroad in the particular state as subject to its statutes, police regulations and public policy; and hence the federal and state governments and commissions in their eagerness to let nothing pertaining to a railroad escape their regulations and control, frequently work at cross-purposes for the assumed benefit of the public, but always at the expense of the railroad companies and their bond and stockholders.

The magnitude of the railroad regulation question considered financially, from the standpoints of the amount of capital invested in railroads; from the point of the number of men employed to keep them as a going concern; from the standpoint of the consumer as being the greatest purchasers of manufactured supplies, and from their vital necessity to the comfort and well being of the people in transporting for them almost every necessity required to maintain life in our great and growing cities, is so largely the greatest business interest in the country, that none other can be compared with it.

The railroads cannot be kept in efficient condition without the expenditure every year of large sums of money. During this very month, one of the leading financiers of New York City appeared before the Interstate Commerce Commission to explain in detail why one of the great railway systems of the country would require the staggering sum of \$355,000,000 of new capital for betterments, improvements, extensions, motive power and rolling stock upon its system within the next ten years; not in order to make more money but to comply, mind you, with the public demands upon it for increased facilities and efficient and economical transportation of freight and passenger traffic.

One would suppose that the law-making powers would cherish and protect such an industry in the interest of all the people against unfair legislation and destructive regulation, but every session of every state legislature is a refutation of that supposition; and the national legislation is not free from the like attitude. It has been stated that at one of the recent sessions of Congress nearly 2,000 bills were introduced affecting railroads, and it may safely be assumed that not one of them was intended to increase their revenues or decrease their cost of operation.

It is state regulation run mad. There is not sufficient ground for such attitude on the part of legislatures, and it cannot be said that there is any justification in the public mind for the legislative attitude.

The railway officials have submitted themselves and their properties in entire good faith to the national control and have not resisted any reasonable state control and are obeying many unreasonable state and municipal regulations and laws which would never be thought of applying to any other industry. The payment of rebates has long since ceased; there are no more favored shippers, all being treated alike without discrimination; one community is not built up at the expense of another community; the rates are no longer adjusted so as to build up monopolies and the wealth of individuals; they are no longer in politics; even in Illinois, as in many other states, the issue of free passes except to those designated by law will soon be a crime; there are no longer railway kings who defy public sentiment; the attitude of present railway officials and financiers is that of men seeking the good will of the people; publication is made to the last detail of railroad operations so that anyone, expert in the science, and the various state and national commissions through their officials, can, by means of them, learn the exact operation of a system, its costs and its net return to the last dollar. Their books are open. Every payment made is

\*Abstract of paper presented before the Society of Railway Financial Officers, Highland Park, Ill., on September 24.

subject to the scrutiny of federal and state commissions. Nothing is concealed or attempted to be or can be concealed.

When it is sought to raise additional means by new financing, the details are laid before the respective commissions and the federal commission by requirement of law, or voluntarily, as evidence of good faith, so that today there is no longer any present reasonable ground for the former feelings of public hostility towards railroads.

Without dilating further upon the legal difficulties which daily arise and call for solution in consequence of this dual legislation and regulation by nation and state, and its certainty of remediless injury to the railroads and to the whole country, we may ask whether any immediate relief can be hoped for.

To this there must be a negative answer, because time is essential to inform the people and to create a new public opinion towards railroads and the enormous capital which is invested in them, and which must receive a fair return if this country is to continue the prosperous and progressive nation it has been to this time. The hostility of the past must by educational work be converted into the friendship of the present and of the future. The people must be educated to a reasonable view of the mutual relationship existing between them and the railroads.

The capital invested in railroads is in effect a trust fund. If the stockholders as owners of that trust fund owe a duty to furnish reasonable facilities of transportation to the public, at rates fixed by the public, and have all the risks of that investment, and if the public in its national, state and municipal character furnishes none of the trust fund and assumes none of the risks, and the railway cannot exist without such fund (as it cannot), then it is the correlative duty of the nation and of the states to see to it that the trust fund is not depleted by unwise legislation, beyond a fair return upon the money invested in the fund.

It seems not to be realized that the trust fund invested in the bonds and stocks of the railroads of this country, amounting to billions of dollars, is owned by hundreds of thousands of holders, men, women and children, and a very large proportion is so held in small lots and upon the income from which the holders are largely dependent for their living. The capital so invested represents past sacrifices and savings, and is as much entitled to consideration as the money invested in a municipal bond, in an individual mortgage, or a house and lot.

We always have great respect when we see the owner about his property ready to protect it. Against the railroads, much hostility has been worked up for real or fancied private and public wrongs, and carried into vicious legislation because the railroad is always visible and the owners of it are never seen about.

It must be brought home to the public by educational work of the most persistent kind that the railway officials and employees are trustees of a trust fund in their charge, in which the public has equal interest with the owners, because dependent upon it for good service, and that they are administering it according to law in perfect good faith, by rendering, first, to the public, prompt and efficient service, for which they should have reasonable rates and, secondly, to secure a fair return to the bond and stockholders on their investment in order to maintain the financial credit of their enterprise, and that they cannot do the impossible things which it is daily asked they shall do, as though the railroads had all the money in the world at their instant command.

Two concrete illustrations of what the writer has in mind may be here given. A collision recently took place on an eastern railroad in which wooden coaches were telescoped and over a score of people were killed. Every railroad man knows that it was not the lack of steel coaches which caused the accident and the loss of life. The accident would have occurred under the circumstances, though it is likely there might have been less loss of life; but a public cry went up for immediate steel equipment of all passenger trains. If the railroads had the money the equipment could not be manufactured in years; but as shown by careful estimates, it would take more than \$600,000,000 to

secure such equipment for all the leading railroads, a proposition impossible to finance now or at any time.

A number of grade crossing accidents, whereby lives were lost through the heedlessness of automobile drivers or owners, has brought a hue and cry for the abolition of all grade crossings, at the cost of the railroads. One of the railway systems has shown by expert estimates that it would cost at least \$600,000,000 to abolish all the grade crossings upon its system alone, and that it has already expended \$62,000,000 to that end, and it could only raise a few millions each year for that purpose.

If public opinion cannot be formed in each state to see the un wisdom of such injurious laws and bring to an end these great grists of unreasonable and even hostile local legislation, then the railroads must turn to the nation for relief.

The chaotic condition of railroad legislation has a parallel in the anarchic, commercial and monetary conditions which existed among the thirteen states between the close of the Revolutionary War in 1781 and the adoption of our present Constitution in 1787. No two states had the same kind of money and no state could keep its paper money at par. Every state having a seaport levied customs tariffs as it pleased upon commerce entering its ports for other states, regardless of the interests of the country as a whole, so that trade came to almost a standstill and bankruptcy was the order of the day.

It was that condition of things which proved the strongest inducement to the adoption of the Constitution. Anything was better than the anarchy which existed. A single government was sought, and it has obtained from that time to this in the Constitution, notably in the so-called commerce clause of the Constitution. Under that clause, as said by the Supreme Court in the Minnesota rate cases, "The power of Congress to regulate commerce among the several states is supreme and plenary. It is complete in itself, may be exercised to its utmost extent and acknowledges no limitations other than are presented in the Constitution."

Local railroad regulation is under present law committed to the individual states, although it may have such a relation to interstate commerce as to be within the reach of federal power. But the court adds—

"In such case, Congress must be the judge of the necessity of federal action. Its paramount authority always enables it to intervene at its discretion for the complete and effective government of that which has been committed to its care, and, for this purpose and to this extent, in response to a conviction of national need, to displace local laws by substituting laws of its own. The successful working of our constitutional system has thus been made possible."

Under that statement of the powers of Congress in the premises, the railroads have a right to look to the nation for protection, not for themselves alone, but for all the industrial interests and the general public, which are dependent upon them for their continued prosperity.

The writer has no desire to see the railroads entirely under the control and regulation of the federal power, but as our forefathers in 1789 found the certainty of strength with the possible evils of one government preferable to living under the losses, vexations and uncertainties of thirteen weak and grasping states, so it ultimately may be the cry of the people themselves that one firm controlling power over the railroads will be better than a mixed control divided among 49 powers with endless vexation and at ruinous cost.

The railroad officials and employees are not alone interested in these vital questions. They affect the public in every relation of life. It should therefore be the pleasure of all citizens to get a correct understanding of the vast interests which are imperiled by unjust legislative treatment, federal, state and municipal, of this the nation's greatest industry, and aid in forming righteous public opinion upon it. For it must never be forgotten that public opinion ultimately in the last analysis makes and maintains the laws we must live under.

## BOSTON & MAINE EXTENSION FROM HINSDALE, N. H., TO BRATTLEBORO, VT.

An important line of the Boston & Maine extends from Springfield, Mass., north along the Connecticut river into northern Vermont and Connecticut over which, in connection with the New Haven, a number of through trains are operated from New York. Between South Vernon Junction, N. H., and Brattleboro, Vt., 11 miles, and also between Windsor, Vt., and White River Junction, 14 miles, the Boston & Maine operates over the tracks of the Central Vermont. In the readjustment of railway conditions in New England, the Boston & Maine has just completed the construction of a new double-track line from Hinsdale, N. H., four miles north of South Vernon Junction on its Asheulot branch on the east side of the Connecticut river, to Brattleboro on the west side of the river, to avoid the necessity of using the tracks of the Central Vermont on the west bank between these points, and will operate the 12 passenger trains in addition to several freight trains now handled on the Central Vermont, on this line. The new line is on the east bank of the river to a point about one mile south of Brattleboro.

This line is about seven miles long and its construction involved the moving of over 1,400,000 yds. of grading, 145,000 yds. of which was rock. It is graded throughout for two tracks, the

to grade. This condition made the operation of steam shovels extremely difficult. It was necessary to support them on a heavy plank grillage, and even then the mud rose 2 ft. through this grillage on several occasions after storms, necessitating pulling the shovels back. At other times the sides of the cut slid in with sufficient force to move the shovels laterally as much as 8 ft. This condition was finally overcome by removing the sliding material in terraces starting at the top and backfilling to the slope line with sand cast in from the top. This operation was repeated until grade was reached. The cut was also excavated 3 ft. below the subgrade and backfilled with sand, while drain tiles were laid in sand along the toe of the slope. These measures proved effective in preventing further slides, and the finished cut gives little indication of the material really encountered. The sand in this and other cuts will be covered with cinders later to prevent its drifting.

With the exception of a bridge 911 ft. long across the Connecticut river, just south of Brattleboro, the structures are comparatively unimportant. This bridge consists of two 250 ft. through combination pin connected and riveted truss spans, with four 80 ft. deck plate girder spans on the north approach, and one 80 ft. deck plate girder on the south approach, and required 2,300 tons of steel. The substructure and through trusses are built for double track while the girders are erected



General View of Connecticut River Bridge.

first of which was placed in service June 23. The maximum grade is 0.5 per cent. and the maximum curvature four degrees. The line is being equipped with automatic signals, and is laid with 85-lb. rail on gravel ballast secured from a pit on the line.

All grading was done by contract by the Holbrook, Cabot & Rollins Corporation of Boston. Because of the heaviness of the work a comparatively large amount of construction equipment was installed, including seven steam shovels, five Brown hoist cranes, 15 40-ton standard gage locomotives and 118 12-yd. air dump cars. All equipment was brought in from the south end of the line over a standard gage construction track built for this purpose with 5 per cent. grades and 20 deg. curves. The roadbed is graded 39 ft. wide in cuts and 31 ft. on fills, with all tracks laid on 13 ft. centers.

With the exception of one fill containing 400,000 yds. of material two miles north of the south end of the line, and a cut requiring the removal of 450,000 yds. immediately adjoining this fill on the north, the grading was comparatively uniform for the entire distance. This cut presented an unusual and difficult problem. The maximum depth was 82 ft. Although all surface indications pointed to the entire cut being composed of sand, when the first 20 ft. of material was removed a very wet sliding clay mixed with quicksand was encountered all the way down

on the westerly track only. The alinement on the bridge is a 4 deg. reverse curve spiralled with 200 ft. of tangent across the northerly truss span. A 0.3 per cent. grade ascends toward the south. The distance from the base of low rail to the surface of the river at normal stage is about 27 ft. The through spans are 41 ft. 8 in. deep center to center of chords, the southerly span being 38 ft. 6 in. wide center to center of trusses, while the northerly span is 32 ft. 4 in. wide, this difference in widths being necessitated by the curvature of the tracks.

The foundations were of concrete up to the water level and stone above that. The southerly abutment was founded on rock. Pier one was built on rock, which at that point was overlaid with 7 or 8 ft. of gravel. This gravel was dredged and on account of the sloping surface of the rock it was leveled off by drilling holes with well drills and blasting. After the site had been leveled, sheeting was driven and the concrete deposited under water. At piers two and three, 8 ft. of gravel was dredged, supporting piles were then driven and the concrete was placed in a timber grillage 5 ft. thick on which stone was laid and the entire grillage was sunk into place by the use of a timber caisson. Sides were attached to the grillage which were removed after it had reached its final position. Piers four, five and six were built on piles driven after the



gravel had been dredged. Sheeting was driven around these piers and was removed after their completion. The north abutment rests directly on gravel, as this material was so hard that piles could not be driven through it. The substructure for this bridge was also built by the Holbrook, Cabot & Rollins Corporation.

As the masonry work was started from the north abutment and proceeded south, the erection of the bridge also started from this end, necessitating placing the single track girder spans first. This was accomplished by means of a self-propelling steel derrick car of 30 tons rated capacity with a 50 ft. steel boom. After the girders for the end span were set with the car standing on the west abutment and the laterals, ties and rails were in place, the girders for the next span were loaded one at a time crosswise on a small four wheel truck or push car and shoved out to the end of the span already erected. The girders were then picked from the push car by the derrick and set in place. This method was necessary to allow the derrick car to get as close as possible to the end of the span previously set, as it was necessary to reach out 42 ft. to place the 82 ft. girders.

The truss spans were erected on falsework by means of the derrick car. For the south span, nine piles 74 ft. to 76 ft. long were driven under each panel point with a floating driver using a steam hammer instead of the usual drop hammer. The water at this point was from 32 ft. to 45 ft. deep and the piles were driven to a penetration of approximately 18 ft. through hard sand and gravel. In spite of the excessive depth of the water, no submarine bracing was used on the piles, as they were all of extra large size and almost perfectly straight from tip to butt. They were cut off 11 ft. below the base of rail and capped and braced in the usual manner.

After completing the falsework, the floor system was placed on the camber blocking, the web members and bottom chord bars were placed and all intermediate and bottom pins driven

pleted, the two end panels were cantilevered over the pier from the falsework, the two end panels of the bottom chord for each truss being made stiff members instead of eye bars to allow them to take the compression resulting from this cantilever action. After the erection was completed the falsework was removed with the derrick car.

The heaviest members placed by the derrick car were the four end top chord sections in the north truss span, each of which weighed 35 tons. In making any heavy lift this car was blocked with one 70 ton Norton jack on each side under the front bolster and was guyed sideways with a set of four sheave manila rope blocks on either side leading from the top



Carrying Girder for Brattleboro Bridge Out on Small Truck.

of the "A" frame down to the floor beams or stringers. Due to unforeseen difficulties encountered in building the substructure, the erection of this bridge was carried on in the winter with snow and ice almost constantly present.

A unique feature in the design of the truss spans was the use of skid girders, these girders being of the latticed type and riveted to the web system of the trusses in a horizontal position about 4 ft. above the deck and designed to serve as a protection to the truss members in case of a derailment on the bridge.

At Brattleboro a new union station with the Central Vermont is planned, and preliminary work is now under way.

This work is all being handled under the direction of A. B. Corthell, chief engineer, Boston & Maine; F. C. Shepherd, engineer of construction, and H. L. Farwell, resident engineer. H. L. Ripley was engineer of construction for the contractors. The Brattleboro bridge was erected by the American Bridge Company of New York. J. B. Gemberling, division erecting manager; H. G. Reynolds, general foreman, and S. Savage, resident engineer.

**THE NEW STATION AT BASLE.**—One of the largest and most expensive railway stations in Europe has just been completed on the Swiss-German frontier at Basle. The station, which is on German territory but touches the Swiss frontier, cost nearly \$15,000,000, and the work of construction took nearly three years.

**NEW LINE FOR SPAIN.**—After serious obstacles were overcome, owing to opposition of competing interests, the Pena de Hierro Copper Mining Company obtained a concession for a railway which will carry its product 12 miles from Pena de Hierro to Castillo de las Guardas, whence it will be brought on the Cala company's railway to Seville for shipment. The Pena company's line is now building and will probably be completed before the close of 1913, and will enable it to ship some 350,000 tons annually. The new railway is another step in the development of the enormous mineral wealth of Seville district. As for dump cars and other railway equipment necessary, the company may be addressed: Pena Copper Mines (Ltd.), Lawrence Pountney Hill, London, E. C., England.



Terracing Slope in Sliding Cut.

with a rail swung from a runner line on the boom of the derrick car. In erecting these spans the material was run out on one track beside the derrick car, which stood on the other track. After the web system and bottom chords had been connected up the top chords were placed in their final position and the top chord pins were driven with a rail swung from a runner line on the boom as above, after which the camber blocking was knocked from under the floor system and the span was swung clear of the falsework.

The other through truss was erected in the same manner except that as the pier on which the south shoes were to rest was not finished until after the span had been practically com-

## AUTOMATIC STOPS AND AUDIBLE SIGNALS. A NOVEL PLAN FOR SOLVING THE RAILWAY LABOR PROBLEM.

BY GEORGE A. CLARK.

The Maryland & Pennsylvania announces that the Jones automatic train stop and cab signal, which has been in use on that road to a limited extent for some time past, is to be installed on a length of seven miles of its line; and it is intended during the coming year to equip the road for its use over a distance of 19 miles more, or 26 miles in all, Baltimore to Belair. The apparatus of the Jones system was briefly described in our issue of April 11, 1913, page 834, in connection with a report on automatic-stop experiments in all parts of the country.

In connection with the present announcement we have gathered the following notes concerning other experiments with automatic stops, these notes being in the nature of a supplement to our April article referred to above.

**CANADIAN PACIFIC.**—The Prentice "wireless" automatic train control apparatus, which was installed experimentally on the tracks of the Canadian Pacific, near Toronto, has been taken up and carried off.

**CHICAGO GREAT WESTERN.**—Nothing seems to have been done with the Gollos automatic stop since the tests reported in the *Railway Age Gazette* last November.

**CHICAGO & EASTERN ILLINOIS.**—The installation of the Miller train control apparatus on this road has not yet been finished; it is expected that preliminary experimental tests will be made within the next month or six weeks.

**CINCINNATI, NEW ORLEANS & T. P.**—See *Queen & Crescent*.

**DELAWARE & HUDSON.**—For the Federal audible signal, see *Delaware, Lackawanna & Western*.

**DELAWARE, LACKAWANNA & WESTERN.**—The automatic train control apparatus made by the Union Switch & Signal Company and installed on this road near Newark, N. J., has been tried; and experiments are still going on. The Federal Signal Company's audible signal is being installed, and preliminary tests will probably be made within a few weeks. The International Signal Company, of New York, will be ready to make tests in a few weeks.

**ERIE.**—The experiments being made under the direction of H. D. Patterson are still going on. No apparatus has as yet been installed on the tracks.

**MARYLAND & PENNSYLVANIA.**—See above.

**NEW YORK CENTRAL & HUDSON RIVER.**—The experiments with the Induction Signal and Safety Company's apparatus have been discontinued. The experiments with manganese rails have not yet progressed far enough to admit of operating tests. These two devices are the only ones now being experimented with on the New York Central.

**NEW YORK, NEW HAVEN & HARTFORD.**—The apparatus of the Union Switch & Signal Company, installed on this road near Hartford, Conn., is nearly ready for a test. The International Signal Company of New York is preparing to make an installation, near the same place, but it will be several weeks before tests of the International apparatus can be made.

**PENNSYLVANIA RAILROAD.**—J. P. Finnegan expects to have his induction apparatus ready for trial within a month.

**PENNSYLVANIA LINES WEST OF PITTSBURGH.**—The Gray-Thurber automatic stop installed on this company's four-track line between Jack's Run and Glenfield, Pa., has been experimented with during the past summer, and a number of formal tests were made. No report of these tests has been published, but the results seem to have been in some important respects unsatisfactory to the officers of the road.

**QUEEN & CRESCENT.**—Experiments with the Buell automatic train stop are still going on.

**ITALIANS TO BUILD RAILWAYS FOR TURKEY.**—Count Nogara, the Italian delegate in connection with the Ottoman debt, has signed a contract with the Ottoman government for the construction of a vast network of railways in the southwest of Asia Minor, with a terminus at Adalia. The new lines will be constructed by Italian capitalists.

The rank and file of employees in the great industries of the country are demanding an increasing voice in the management of the industries in which they labor. This suggestion has been very much in evidence in recent comment on the relation of capital and labor. At the same time, we are informed that labor is becoming increasingly inefficient, that compared with the burden carried by capital the workers of this country are not increasing their output in proportion to the improvement they have secured in working conditions and compensation.

Whatever else may be noted, at least three facts appear to characterize the present relations of railroad employees and employers.

(1) Employees belonging to labor organizations have placed the interest of the company secondary to that of the organization.

(2) Labor leaders have tended to adopt an irresponsible attitude with reference to the ability of the companies to comply with their demands.

(3) There is mutual distrust between the employees and the companies as to their willingness and ability, respectively, to play the game fairly at all times and under all conditions.

As a programme involving the immediate realization of certain ends, in this case the elimination of certain types of favoritism, increased pay and better working conditions generally, there is no effective method by which the merit of the labor programme can be denied. By means of organization certain classes of railroad employees have been able to materially better their condition. Without organization, certain classes of railway labor, notably the station agents, clerks and others, are but little better off than they were twenty years ago. Certainly, such a comparison is an effective answer to the employee in doubt as to the first object of his loyalty. However apparent the ultimate fallacy in such an arrangement, there is no denying that at present the organization man has been well rewarded for his loyalty. To excuse or explain the conditions under which this situation has arisen will not eliminate this obvious fact. One of the most pressing problems arises out of this condition. How can the railroad employee be impressed with the fact that loyalty to the interest of the company will be more profitable to him than loyalty to an organization which at present holds a sort of Robin Hood relation to the railroad industry and the public at large? This problem is more fundamental than that underlying an "efficiency campaign" or a "safety first" movement. Given loyal, satisfied employees, and you will have an efficient organization and a maximum of safety both for employees and for the public.

Labor leaders have been inclined to take the position in recent controversies that it was no concern of theirs as to the manner in which money would be provided to meet their demands. In a recent editorial in this magazine attention was very properly called to the high-handed manner in which they were carrying themselves. Such an attitude is a menace to the welfare of not only the railroad industry but the entire industrial and commercial life of the country. Such an attitude has become possible because of the increasing complexity of our life accompanied by a continual strengthening of the organization of certain classes of employees. Some way must be devised which will make it possible for labor leaders to appreciate not only their own position, but the needs of other interests in the same industry.

No more serious than the two conditions just cited, but certainly more regrettable, is the growing distrust on the part of both employees and employers. The recent controversy furnishes good material on this point. First, the labor leaders made a statement comparing the increases in dividends as contrasted with increases in wages of employees during the past twenty years. A novice at statistics would have known at a glance that the statement as to increases in dividends was not representative, that it did not take into account the enormous amount of inter-company payments. To an outsider it appeared that the state-

ment was presented with the hope that it would mislead. Certainly confidence will never be established by such methods. On the other hand, we have the managers presenting the rather startling proposition immediately following the passage of an act designed to meet a particular situation and at once, that not only the questions raised by the employees be arbitrated, but the whole question of wages, conditions of employment, etc., be opened at the same time. No one will deny the right of the managers to avail themselves of the opportunity accorded by the new law, but certainly their demands presented at the time and in the manner they were would not tend to create confidence on the part of employees.

The ascendancy of the organization as opposed to the employer, the evident irresponsible attitude of labor leaders and mutual distrust, are at least three unfortunate phases of present day labor problems in the railroad business.

How may these conditions be eliminated? How may the demand on the part of labor for a more prominent voice in the management of all industry be adequately met? How can both employer and employee arrive at a better understanding of the problems that each is confronted with?

As a small investor in railroad securities it has appeared to me that representatives of the employees might very well be represented on the directorates of railroad corporations. Such a suggestion may be regarded as revolutionary in our conception of the relation of labor and capital and in our understanding of the functions of a director in a railroad corporation. However, without reference to the novelty of the proposal, a frank consideration of the present difficulties of capital and labor and the particular merit of this suggestion may be profitable.

Briefly, four tests may very properly be applied to such a suggestion.

(1) Is an employee qualified to assume such a relation to the corporation employing him?

(2) Would it tend to eliminate the evils complained of?

(3) Would it be good public policy?

(4) How could it be best accomplished?

Aside from the technical qualifications as a director which it would be necessary for the candidate to possess, in the way of stock ownership, etc., there is nothing essentially different from the standpoint of the railroad corporation in the proposed relation it would hold to its employees and the relation which it now almost universally holds to its bankers. We have accepted the fact that the banking representative of a railroad corporation should have some voice in its management. In this instance the railroad is in the market for money with which to carry on its development. The banker wishes to be able to assure his clients that the securities are what they are represented to be, and that the management is honest and able. Carrying the analogy a step farther, the railroad is in the market for labor. Representatives of labor should be in a position to assure themselves that the conditions of employment are the best that are consistent with the welfare of the organization.

The second question may be answered in the affirmative. Such a relationship would tend to eliminate the evils complained of. It would identify the interests of the employee with the organization with which he is connected. A number of attempts have been made at various times to give employees a more permanent interest in the organization than that of the pay envelope. Various schemes of stock ownership, etc., have been worked out with varying success, but so far as is known in no instance in the railroad field have these programmes been carried to their logical conclusion and the possession of the stock made the basis of representation on the board of directors.

The most effective means of correcting the evil of irresponsibility on the part of labor leaders is an opportunity for them to secure first hand knowledge of the problems of other men concerned in the industry. Such knowledge may be made a tremendous influence for reasonableness in the adjustments which must be made from time to time in any industry. Intelligent co-operation not only on the part of the railroad capitalist, but

also on the part of the railroad employee, is the only basis upon which any security for the future may be had. Too many representatives of capital have been imbued with a desire to do something for their employees, and too few have as yet reached the point where they are willing to work with them. Paternalism in industry, however well intentioned, is no more acceptable than in government. Co-operation between the workers and the investors in the railroad industry will eliminate an apparent necessity for any form of paternalism. Co-operation will operate to direct the loyalty of employees along proper channels, it will eliminate a dangerous type of irresponsible leadership, and it will do away with occasion for distrust in very many of the relations of the two interests.

Such a suggestion, if adopted, would be good public policy. There is nothing about the railroad business at the present time, subject as it is to federal and state supervision, which would make it unwise for employees to be represented in the manner suggested. On the contrary, it would give confidence to employees generally in the safety and good faith with which investments might be made in railroad securities. It would discourage excessive demands for any particular class of employees or investors for that matter. It would develop a sense of permanence in the relation of the average employee to his company.

The selection of directors should be made as now, with the added provision that the employees through their investment association, through their organization, or by whatever agency was best adapted to the needs of a particular company, should nominate several candidates from which the existing board could make a selection. This is principally an administrative question and of necessity a method should be developed to meet each situation. The selection should be representative both for the employees and the needs of the investors.

In some form or another labor will have an increasing voice in the management of the industries of the future. The suggestion outlined affords one logical and natural method by which this demand may be met and by which certain serious difficulties may be overcome. The company which will adopt such a suggestion will emphatically endorse the principle of co-operation between railroad employees and railroad investors in working out their mutual problems.

## SAFETY SQUIRT FOR SPRINKLING COAL.

The long established and simple method of wetting the coal in the tender by means of a squirt hose is one of the most recent locomotive attachments to receive radical improvement. The last

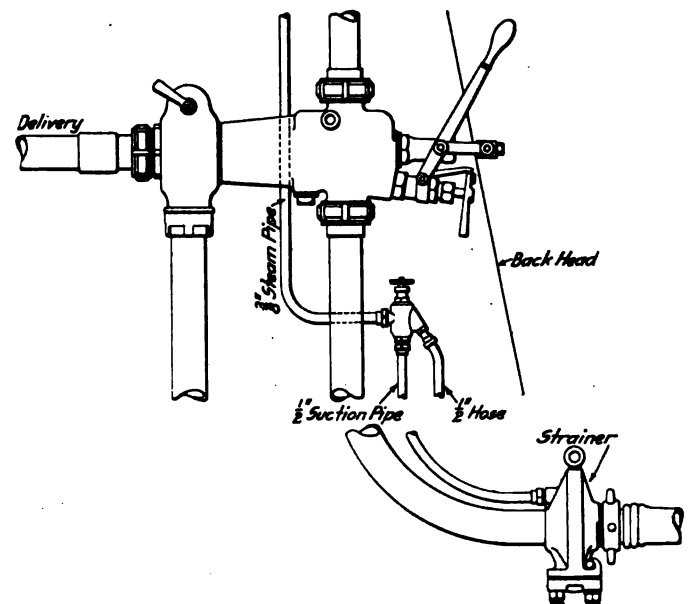

Sellers Safety Squirt Applied to a Locomotive.

annual report of the chief inspector of locomotive boilers of the Interstate Commerce Commission records 243 accidents due to the failure of such apparatus, of which a large proportion might have been avoided by the introduction of a safety device. These accidents were due to the bursting of the hose and the scalding of the enginemen and to the slipping of the hose from its union, etc.

The old arrangement has, however, the advantage of simplicity and ease of operation. It requires little trouble to open the valve from the injector delivery or from the boiler, and were it not for the excessive temperature of the water used and the high pressure in the hose, there would be little danger of accident. A

temperature of the water is about 110 deg., which is suitable for either winter or summer. The operation of this safety squirt is the same whether it is placed above or below the level of the water in the tank; the internal construction prevents outflow through the hose when it is placed under a head of water, or if the injector is used as a heater. The suction branch contains a water check valve which is normally closed, but opens automatically when steam is admitted by the valve at the top. This device is now in quite extensive use and is giving good service.



**Safety Device for Wetting Locomotive Coal in the Tender.**

superseding device therefore must be convenient and simple to operate, and deliver a low pressure jet of cool water.

The accompanying illustrations show a safety squirt, which has been produced by William Sellers & Company, Incorporated, Philadelphia, Pa. It is operated by steam from the boiler and is connected by a 1/2-in. pipe to the strainer on the left hand injector for its water supply. Opening the valve at the top produces a strong suction which lifts the water supply, discharging a low pressure jet through a 5/16-in. nozzle the full length of the tender. The

## HYDRAULIC FORGING AND BENDING PRESS.

The illustration below shows a hydraulic forging and bending press for engine and car shop work, such as the making of equalizer bars and other heavy bending and straightening which is commonly done in a geared type of bulldozer. This machine will handle a wide range of work and the application of the power is direct and positive. A further advantage claimed for it is that of being safe from breakage due to the operator putting in work which has become too cold or is too large, which in a geared type of press results in stripped gears, etc. A number of these machines have been installed in locomotive building plants; the usual capacity is 100 tons arranged so that either 40, 60, or 100 tons may be used, depending on the size of the work. This results in a saving of power. A large pull-back provides a quick return stroke and ample power for stripping the dies. The field for such a press in a locomotive or car shop is large and it is claimed for this machine that it will accomplish such work at minimum cost.

This press is manufactured by the Chambersburg Engineering Company, Chambersburg, Pa.

**CADIZ-ALGECIRAS-MALAGA RAILWAY, SPAIN.**—The project for a railway connecting Cadiz more directly with Algeciras (Gibraltar) and with Malaga meets with the approval of the traveling public and the shippers who have hitherto been obliged to depend upon means of communication that are at best inadequate. The present mode of travel between Cadiz and Algeciras is either by sea or by motor bus, the latter a very pleasant journey for travelers without much luggage. This popular motor trip of about 68 miles costs only \$4.50, or less than half the railway fare from Cadiz to Algeciras; for the journey by rail involves a long detour way of Seville, and occupies at least 15 hours. Thus the advantage of the proposed railway are obvious—connecting Cadiz more directly with Gibraltar, and Gibraltar more directly with Malaga. The route from Cadiz is to pass through Chiclana, Medina and Alcala, towns entirely without railway facilities; crossing the Algeciras-Bobadilla railway, to Castellar; thence south to Algeciras and northeast to Malaga.

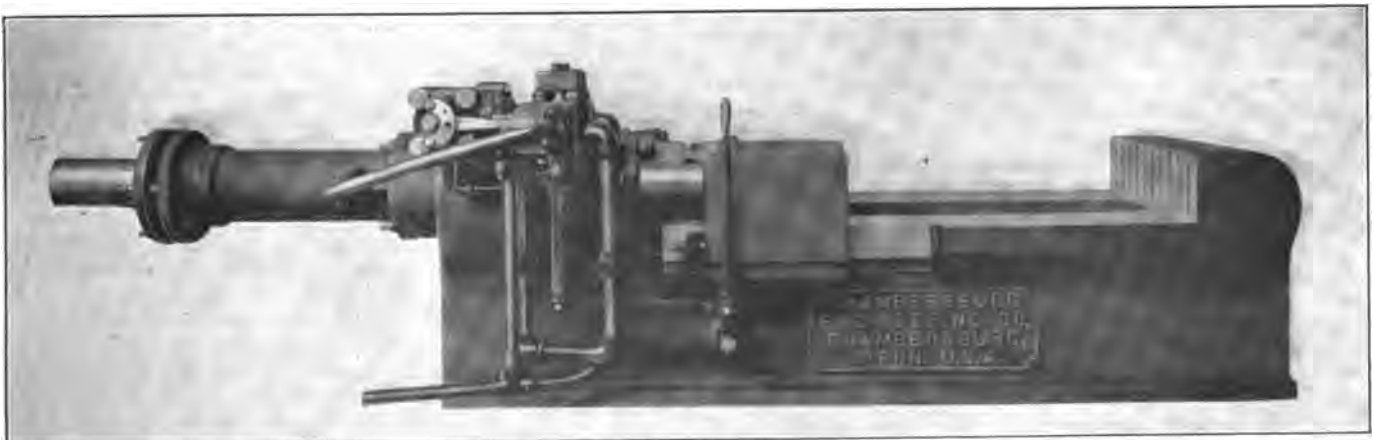

**Hydraulic Press for Heavy Forging and Bending.**

## General News.

The Illinois Central has recently ordered drinking cups to supply 4,000 passenger cars. They will be sold from slot machines at a cent apiece.

Car repair shops of the Armour Car Lines at Chicago, including a number of refrigerator cars, were destroyed by fire on the night of October 3.

At the bowl-shaped track at Brooklands, near London, England, October 1, an automobile of 30 horse power was run 1,079.26 miles in 12 hours, an average rate of more than 89 miles an hour. The best previous record was made on the same course last May, about 78 miles an hour.

According to the latest reports from Washington that clause in the urgent deficiency appropriation bill which is designed to put an end to the Commerce Court, has been as modified that the judges of this court will be retained as judges of the Circuit Courts, subject to assignment, by the chief justice of the Supreme Court, for duty in the Court of Appeals.

The arbitrators considering wages of conductors and trainmen have continued their hearings in New York City during the past week. John G. Walber, assistant to the third vice-president of the Baltimore & Ohio, has been on the stand two days, giving testimony concerning wages paid on different railroads. Testimony was also given by John McMullen, a brakeman of the Pennsylvania; Michael Sammon, a yard conductor of the same road, and F. L. Howard, a conductor of the Chicago, Indiana & Southern.

The Baltimore & Ohio has instructed enginemen and firemen to take special care to prevent locomotives around passenger stations from "popping off." A mother carrying an infant in her arms and looking after the safety of young children traveling with her, might be scared by a popping engine and drop the child. Again, the "commuter" dressed for a ball or theater party, hurrying along the platform might get an unwelcome vapor bath. All annoyances of this kind, says the press agent, are to be done away with.

The New York, New Haven & Hartford, announcing its new time table last Sunday, issued a statement showing how the through trains between New York and Boston are made a trifle slower in nearly every case. The fastest trains, running through, 234 miles, in five hours, will henceforth take five hours, ten minutes. Some of the fast trains between New York and Springfield, 136 miles, have been made 25 minutes slower. On lines where the block system is not in force the time interval between trains in all cases is at least ten minutes. A very few suburban trains have been taken off. Of two thousand passenger trains on the timetables, approximately two-thirds have been changed.

A conference regarding the proposed abolition of railway grade crossings in St. Louis was the subject of a conference held October 2 between representatives of the railways of the state, members of the Public Service Commission, the mayor of St. Louis, and the president of the board of public improvements. J. L. Harrop, engineer for the Public Service Commission, presented a report describing the principal grade crossings in the city which he recommended should be abolished as soon as possible. The railway men expressed a willingness to co-operate with the city and the state, but said there were not sufficient funds on hand to do all the work at once. They agreed to furnish plans and assist the commission. A further conference will be held on October 13, for detailed consideration of various plans.

A protest from organized labor, presented in the Chicago city council, caused a delay in the plans of the agitators for electrification last Monday. It had been planned to call up for passage the ordinance recommended by the committee on railway terminals during the summer, prohibiting the operation of trains by any power producing smoke or noxious gases, when the protest was received by the committee, signed by representatives of the conductors', engineers', firemen's, trainmen's and switchmen's organizations, who claimed to represent 58,500 voters, demanding that they be given a hearing before the subject was considered

in the city council. As a result the ordinance was referred back to the committee. The employees declared that the ordinance would be unfair to them, would endanger the lives of railroad employees, and would cause many of them to lose their employment after the change from steam to electricity.

The presidents or other officers of fifteen Illinois railways attended a conference at Springfield on Saturday, October 4, with Governor Dunne and Chairman Berry of the Illinois Railroad and Warehouse Commission, to discuss means of reducing grade crossing accidents, particularly automobile accidents, in the state. The conference was called by the governor. The railway men promised their heartiest co-operation with the state administration on plans for improving the conditions at grade crossings, which will be taken up by the new public utilities commission, and all agreed to furnish a list of their most dangerous crossings. Track elevation was not especially considered, but most of the discussion was concerned with plans for eliminating hog-back and diagonal crossings with highways, which have proved especially dangerous since the rapid growth of automobile travel. While the railway men were unanimous in declaring that the present condition should be remedied, most of them placed a large part of the responsibility for accidents on the public and on automobile drivers. President Worthington of the Chicago & Alton, advocated a state law compelling all automobile drivers to bring their cars to a stop before crossing railway tracks. President Delano of the Wabash agreed with him, but thought that the roads themselves could materially improve the situation by eliminating diagonal crossings and removing obstructions to the view. J. P. Ramsey, president of the Chicago, Peoria & St. Louis, advocated the application of a portion of the state automobile tax revenue to the expense of removing grade crossings. Further regulation was also recommended for automobile drivers, on the ground that while chauffeurs are required to be examined and to hold proper licenses, the owners who may have had no experience may run their cars without regulation.

### St. Paul Union Station Burnt Down.

This station, which was used by all railways entering the city, and was one of the city's landmarks, was almost completely destroyed by fire on the night of October 3. Negotiations between the railways and the city looking to the construction of a new station have been in progress for several years, without an agreement having been reached.

### Oil Burning Locomotives Demanded in Massachusetts.

During the past ten years Massachusetts has been engaged in an eminently practical campaign to stimulate a general interest in the better management of forests. Lumber manufacturers have already begun to plant pines on their cut-over lands. Cape Cod towns sent a delegation of fifty to the forest fire hearing before the Public Service Commission on the petition of the state forester that the New York, New Haven & Hartford Railroad be required to use oil-burning locomotives in Barnstable county. It was proved to the satisfaction of the commission, so the chairman stated publicly at the close of the day, that the forest fire situation along the railroad on the Cape is critical. In the past six years there have been almost an even thousand fires in that region and 79 per cent. of these originated from the railroad. During the past season alone there were nearly 300 fires set by the locomotives. More than one resident testified that great as was the property damage, the nervous strain under which they lived in dry seasons was the more dreaded, and they would cheerfully submit to a raise of fares if that would enable the road to effectively prevent a recurrence.

Cape Cod's great resource today is its seaside summer colonies, attracted by the charm of the climate and the beauty of its coast. . . . Already many wide areas have been reduced by the fires to mere sand barrens. Even the worst of these wastes, however, are capable of reclamation, through forest planting, and the state stands ready to aid in their development, if, and only if the fire hazard, for which the railroad is mainly responsible, can be reduced in a reasonable degree. But the railroad says that to substitute oil for coal would add \$80,000 a year to operating costs. The forester regards this figure as far too high, and if the cost of fires is properly cred-

ited, it is not impossible that the increase will wholly disappear. Even if it does cost more, if it shall appear to the commission that the burning of oil fuel is the remedy to apply in the interest of the community, it would seem to be its duty to order it carried out, and then, if need really exists, take the property owners at their word, and authorize the railroad to recoup by increasing its transportation charges.—*Boston Transcript*.

**Railroad Men in the Legislature.**

In the lower House of the North Carolina legislature last week there was read a report from the Corporation Commission, containing a list of members of the legislature and state officers who have railroad passes. The reading of the list led to many complaints and explanations, but it appears that the terms on which the holders of these passes enjoy the privilege are more or less legitimate, as is shown by the following explanatory statement:

Representatives W. C. Dowd, on account of advertising contracts for the *Charlotte News*; Walter Murphy, director of the Yadkin Railroad; R. F. Mintz, advertising contract *Mount Olive Tribune*; F. A. Woodard, local counsel Atlantic Coast Line and Norfolk Southern; J. Frank Ray, local counsel Southern Railway; J. A. Bolick, locomotive engineer Southern Railway; J. T. Foy, agent Scotts Hill station, Atlantic Coast Line; Dr. B. F. MacMillan, local surgeon Atlantic Coast Line, Red Springs; H. A. Page, general manager Bennettsville & Cheraw Railroad; C. R. Cofield, station agent Atlantic Coast Line; D. P. Dellinger, local counsel Seaboard Air Line; A. A. F. Seawell, special counsel Seaboard Air Line; W. H. Weatherspoon, local counsel Seaboard Air Line; Mark Majette, local counsel Norfolk Southern; R. L. Philips, local counsel Southern.

Senate.—A. D. Ivie, local counsel Southern Railway; J. P. Cook, secretary-treasurer North Carolina Railroad; A. T. Grant, local counsel Southern Railway; O. F. Mason, division counsel Southern Railway; George B. McLeod, director Raleigh & Charleston Railway; J. H. Bridgere, local counsel Seaboard Air Line; H. W. Stubbs, local counsel Atlantic Coast Line.

State Officers.—Dr. Joseph Hyde Pratt, state geologist, director State University Railroad; Hugh MacRae, of State Geological Board, director of North Carolina Railroad; State Auditor W. P. Wood, director of High Point, Randleman, Asheboro & Southern Railroad; Commissioner of Labor and Printing M. L. Shipman, advertising contract for French Broad Hustler; Corporation Commissioners required to be transported free by statute; T. G. Cobb, clerk of the House, on account of advertising contract for *News-Herald*, Morganton.

**Wireless Telegraph Extensions.**

Edward J. Nally, vice-president and general manager of the Postal Telegraph & Cable Company, and formerly for many years with the Western Union, has resigned and has taken a similar position with the Marconi Wireless Telegraph Company of America. The latter company has just made a contract with the Norwegian government for the erection of a wireless station in Norway, connecting with a station in Massachusetts. A chain of Marconi stations is being planned to give wireless service throughout the entire world. The company has bought land for the proposed station on the Massachusetts coast and plans to erect the duplex system, by which wireless messages can be received and sent at the same time. The operation of the system will be on the same plan as that to be employed between the station now building in New Jersey and the new station in England. The Norwegian government is making arrangements to connect with Sweden and Denmark. It is estimated that each wireless station will cost in the neighborhood of \$500,000. The Marconi Company proposes to connect the United States with Honolulu by two stations to be erected in California at Bolinas and Marshalls. Contracts have been awarded to The J. G. White Engineering Corporation of New York for the construction of the receiving and sending stations in New Jersey, California and the Sandwich Islands.

**President Worthington on the Closed Shop.**

Organized labor has recently put up to the management of the railroad, the question of a closed shop at Bloomington. It is rather hard to conceive how these men reconcile a request of

this nature with the rights which they demand for themselves—no discrimination in the employment of union labor. As a matter of fact, discrimination for or against union labor is unlawful, it is a moral crime—not that the railroad company wishes to discriminate against organized labor, for such is not the case. Organization, which has for its object the bettering of conditions, upbuilding and protecting, is worthy and honorable, and is welcomed by the railroad company because it is elevating; but labor, organized or not, can never gain a position of wholesome permanency by arbitrary methods of closed shop and limited output. There is work enough for all, that much is sure; and if the organization of labor is founded on proper principles, it will use every means to promote efficiency, it will take its feet out of the trough, and adopt more wholesome measures of protection which do not exclude the interests of the railroad itself. Otherwise organized labor, poor blind Samson shorn of a crowning glory, may rattle its chains and pull the temple down upon itself.—*From an address by President B. A. Worthington of the Chicago & Alton, at the dedication of the new passenger station at Bloomington, Ill.*

**Trespass Laws More Needed Than Steel Cars.**

The Bureau of Railway News and Statistics is distributing postal cards on which is printed, under the above caption, the following table of fatalities charged to United States railways in 23 years, 1890 to 1912, inclusive:

	Killed.	Per Cent.
Trespassers .....	103,566	53.8
Employees through their own fault or mischance....	40,497	25.7
Other persons through their own fault or mischance..	18,328	9.5
Employees in accidents to trains..... (a) 13,630		7.1
Passengers through their own fault or mischance....	4,219	2.2
Passengers in accidents to trains.....	3,302	1.7
Total for 23 years.....	192,542	100.0
<i>Analysis.</i>		
Through their own fault or mischance.....	175,610	91.2
In accidents to trains.....	16,932	8.8
(a) Of these, at least 50 per cent. are due to the negligence or carelessness of the victim.		

"So long as legislators, commissions and critics rivet their attention on steel cars, which may cause, but never avert, a collision or derailment, the tale of railroad fatalities will grow along the line of the greatest percentage of causes," says the bureau.

**Safety First Meeting Illinois Central Time Service Department.**

A "Safety First" meeting of the time service department of the Illinois Central and Yazoo & Mississippi Valley was held at the Stratford Hotel, Chicago, on September 8 and 9. The meeting was presided over by Webb C. Ball, general time inspector. Various question of mutual interest to the company and the inspectors were discussed, having in mind the betterment of the time service, such as the changing of the time of inspections and a more rigid enforcement of the weekly comparisons and efficiency tests to ascertain whether or not employees have in their possession of all times weekly comparison cards. A permanent organization of the authorized local watch inspectors of the Illinois Central system was effected.

Among the points taken up was the subject of establishing a uniform price for standard watch repairing and the importance of allowing no one but reliable watchmakers to handle employees' watches. A schedule was presented, voted on and passed. Mr. Ball in remarking on this said in part, "The spirit we want to inculcate in the minds of railroad men is that when they come to a railroad watch inspector, they are getting the best it is possible to obtain. The watchmakers selected by the railroad company for this work are the best in the profession. When a railroad man leaves his watch for repair, with a local watch inspector he secures a standard loaner watch, which he is given to carry free of charge while his watch is being taken care of. These loaner watches meet the requirements of the time service and are the investment of the local watch inspector and are given just as careful rating and attention as the employee's own watch. The figures showing the number of these watches being carried in service, loaned by the local watch inspector each month, are really remarkable."

It was unanimously agreed that standard plain dials be adopted for use on all railroad standard watches, and that all fancy dials with a circle of marginal signs or other "freak" designs be con-

demned as being unreliable and unsafe for railroad service

The inspectors also went on record as condemning the practice of placing pictures on watch dials or crystals. The meeting closed with general discussion of the rules now in effect, and a long talk by Mr. Ball, giving instructions to the inspectors as to the proper handling of the service. The arrangements for the meeting were carried out by W. F. Hayes, assistant general time inspector, through instructions issued by T. J. Foley, general manager of the Illinois Central, and Webb C. Ball, general time inspector.

#### Railway Fire Protection Association.

The Railway Fire Protection Association was organized at a meeting held in Chicago on Tuesday and Wednesday of this week with forty members. The officers elected were: President, E. F. Elmore, superintendent of insurance of the Southern at Washington, D. C.; vice-president, Paul Hevener, assistant supervisor of the insurance fund of the Rock Island at Chicago; secretary-treasurer, C. B. Edwards, fire insurance agent of the Mobile & Ohio at Mobile, Ala. A full report of the meeting with an abstract of the papers presented will be published next week.

#### Canadian Railway Club.

At the monthly meeting of the Canadian Railway Club, to be held at the Windsor hotel, October 14, a lecture will be delivered by R. F. Uniacke, bridge engineer, National Transcontinental Railway, entitled Construction Work on the National Transcontinental Railway. This lecture will be illustrated by stereopticon views.

#### MEETINGS AND CONVENTIONS.

*The following list gives names of secretaries, dates of next or regular meetings, and places of meeting.*

- AIR BRAKE ASSOCIATION.—F. M. Nellis, 53 State St., Boston, Mass. Next convention, May, 1914.
- AMERICAN ASSOCIATION OF DEMURRAGE OFFICERS.—A. G. Thomason, Boston, Mass. Convention, May 19, 1914, St. Louis.
- AMERICAN ASSOCIATION OF GENERAL PASSENGER AND TICKET AGENTS.—W. C. Hope, New York. Annual meeting, October 14-15, Philadelphia, Pa.
- AMERICAN ASSOCIATION OF FREIGHT AGENTS.—R. O. Wells, East St. Louis, Ill. Next convention, April 21, Houston, Tex.
- AMERICAN ASSOCIATION OF RAILROAD SUPERINTENDENTS.—E. H. Hartman, St. Louis, Mo.; 3d Thursday and Friday in May.
- AMERICAN ELECTRIC RAILWAY ASSOCIATION.—H. C. Donecker, 29 W. 39th St., New York. Next convention, October 13-17, Atlantic City, N. J.
- AMERICAN ELECTRIC RAILWAY MANUFACTURERS' ASSOC.—H. G. McConnaughy, 165 Broadway, New York. Meetings with Am. Elec. Ry. Assoc.
- AMERICAN RAILWAY ASSOCIATION.—W. F. Allen, 75 Church St., New York. Next meeting, November 19, 1913, Chicago.
- AMERICAN RAILWAY BRIDGE AND BUILDING ASSOCIATION.—C. A. Lichy, C. & N. W., Chicago. Convention, October 21-24, 1913, Montreal.
- AMERICAN RAILWAY ENGINEERING ASSOCIATION.—E. H. Fritch, 900 S. Michigan Ave., Chicago. Next convention, March 17-20, Chicago.
- AMERICAN RAILWAY MASTER MECHANICS' ASSOCIATION.—J. W. Taylor, Old Colony building, Chicago.
- AMERICAN RAILWAY TOOL FOREMEN'S ASSOCIATION.—A. R. Davis, Central of Georgia, Macon, Ga.
- AMERICAN SOCIETY FOR TESTING MATERIALS.—Prof. E. Marburg, University of Pennsylvania, Philadelphia, Pa.
- AMERICAN SOCIETY OF CIVIL ENGINEERS.—C. W. Hunt, 220 W. 57th St., New York; 1st and 3d Wed., except June and August, New York.
- AMERICAN SOCIETY OF ENGINEERING CONTRACTORS.—J. R. Wenlinger, 11 Broadway, New York; 2d Tuesday of each month, New York.
- AMERICAN SOCIETY OF MECHANICAL ENGINEERS.—Calvin W. Rice, 29 W. 39th St., New York.
- AMERICAN WOOD PRESERVERS' ASSOCIATION.—F. J. Angier, B. & O., Baltimore, Md. Next convention, January 20-22, 1914, New Orleans, La.
- ASSOCIATION OF AMERICAN RAILWAY ACCOUNTING OFFICERS.—C. G. Phillips, 143 Dearborn St., Chicago. Annual meeting, May 28, Atlantic City, N. J.
- ASSOCIATION OF RAILWAY CLAIM AGENTS.—C. W. Egan, B. & O., Baltimore, Md. Next convention, May, 1914, St. Paul, Minn.
- ASSOCIATION OF RAILWAY ELECTRICAL ENGINEERS.—Jos. A. Andreucetti, C. & N. W. Ry., Chicago. Annual convention, October 18-24, Chicago.
- ASSOCIATION OF RAILWAY TELEGRAPH SUPERINTENDENTS.—P. W. Drew, 112 West Adams St., Chicago. Next convention, May 20-23, New Orleans, La.
- ASSOCIATION OF TRANSPORTATION AND CAR ACCOUNTING OFFICERS.—G. P. Conard, 75 Church St., New York. Next meeting, December 9-10, Galveston, Tex.
- ASSOCIATION OF WATER LINE ACCOUNTING OFFICERS.—W. R. Evans, Chamber of Commerce, Buffalo, N. Y.
- BRIDGE AND BUILDING SUPPLY MEN'S ASSOCIATION.—H. A. Neally, Joseph Dixon Crucible Co., Jersey City, N. J. Meeting with American Railway Bridge and Building Association.
- CANADIAN RAILWAY CLUB.—James Powell, Grand Trunk Ry., Montreal, Que.; 2d Tuesday in month, except June, July and Aug., Montreal.
- CANADIAN SOCIETY OF CIVIL ENGINEERS.—Clement H. McLeod, 413 Dorchester St., Montreal, Que.; Thursday, Montreal.
- CAR FOREMEN'S ASSOCIATION OF CHICAGO.—Aaron Kline, 841 North 50th Court, Chicago; 2d Monday in month, Chicago.
- CENTRAL RAILWAY CLUB.—H. D. Vought, 95 Liberty St., New York; 2d Thurs. in Jan. and 2d Fri. in March, May, Sept., Nov., Buffalo, N. Y.
- CIVIL ENGINEERS' SOCIETY OF ST. PAUL.—L. S. Pomeroy, Old State Capitol building, St. Paul, Minn.; 2d Monday, except June, July, August and September, St. Paul.
- ENGINEERS' SOCIETY OF PENNSYLVANIA.—E. R. Dasher, Box 704, Harrisburg, Pa.; 1st Monday after second Saturday, Harrisburg, Pa.
- ENGINEERS' SOCIETY OF WESTERN PENNSYLVANIA.—E. K. Hiles, Oliver building, Pittsburgh; 1st and 3d Tuesday, Pittsburgh, Pa.
- FREIGHT CLAIM ASSOCIATION.—Warren P. Taylor, Richmond, Va. Next convention, May 20-22, Galveston, Tex.
- GENERAL SUPERINTENDENTS' ASSOCIATION OF CHICAGO.—E. S. Koller, 226 W. Adams St., Chicago; Wed. preceding 3d Thurs., Chicago.
- INTERNATIONAL RAILWAY CONGRESS.—Executive Committee, 11, rue de Louvain, Brussels, Belgium. Convention, 1915, Berlin.
- INTERNATIONAL RAILWAY FUEL ASSOCIATION.—C. G. Hall, 922 McCormick building, Chicago. Annual convention, May 18-22, Chicago.
- INTERNATIONAL RAILWAY GENERAL FOREMEN'S ASSOCIATION.—Wm. Hall, 829 West Broadway, Winona, Minn. Next convention, July, Chicago.
- INTERNATIONAL RAILROAD MASTER BLACKSMITHS' ASSOCIATION.—A. L. Woodworth, Lima, Ohio. Next convention, third Tuesday in August.
- MAINTENANCE OF WAY & MASTER PAINTERS' ASSOCIATION OF THE UNITED STATES AND CANADA.—W. G. Wilson, Lehigh Valley, Easton, Pa. Next convention, November 18-20, Louisville, Ky.
- MASTER BOILER MAKERS' ASSOCIATION.—Harry D. Vought, 95 Liberty St., New York.
- MASTER CAR BUILDERS' ASSOCIATION.—J. W. Taylor, Old Colony building, Chicago.
- MASTER CAR & LOCOMOTIVE PAINTERS' ASSOC. OF U. S. AND CANADA.—A. P. Dane, B. & M., Reading, Mass.
- NATIONAL RAILWAY APPLIANCE ASSOC.—Bruce V. Crandall, 537 So. Dearborn St., Chicago. Meetings with Am. Ry. Eng. Assoc.
- NEW ENGLAND RAILROAD CLUB.—W. E. Cade, Jr., 683 Atlantic Ave., Boston, Mass.; 2d Tuesday in month, except June, July, Aug. and Sept., Boston.
- NEW YORK RAILROAD CLUB.—H. D. Vought, 95 Liberty St., New York; 3rd Friday in month, except June, July and August, New York.
- NORTHERN RAILROAD CLUB.—C. L. Kennedy, C. M. St. P., Duluth, Minn.; 4th Saturday, Duluth.
- PEORIA ASSOCIATION OF RAILROAD OFFICERS.—M. W. Rotchford, Union Station, Peoria; 2d Thursday.
- RAILROAD CLUB OF KANSAS CITY.—C. Manlove, 1008 Walnut St., Kansas City, Mo.; 3d Friday in month, Kansas City.
- RAILWAY BUSINESS ASSOCIATION.—Frank W. Noxon, 2 Rector St., New York. Annual dinner, second week in December, 1913, New York.
- RAILWAY CLUB OF PITTSBURGH.—J. B. Anderson, Penna. R. R., Pittsburgh, Pa.; 4th Friday in month, except June, July and August, Pittsburgh.
- RAILWAY ELECTRICAL SUPPLY MANUFACTURERS' ASSOC.—J. Scribner, 1021 Monadnock Block, Chicago. Meetings with Assoc. Ry. Elec. Engrs.
- RAILWAY FIRE PROTECTION ASSOCIATION.—C. B. Edwards, Mobile & Ohio, Mobile, Ala. Next meeting, October 7, Chicago.
- RAILWAY GARDENING ASSOCIATION.—J. S. Butterfield, Lee's Summit, Mo.
- RAILWAY DEVELOPMENT ASSOCIATION.—W. Nicholson, Kansas City Southern, Kansas City, Mo. Next meeting, November 11-12, Baltimore, Md.
- RAILWAY SIGNAL ASSOCIATION.—C. C. Rosenberg, Bethlehem, Pa. Convention, October 14, Nashville, Tenn.
- RAILWAY STOREKEEPERS' ASSOCIATION.—J. P. Murphy, Box C, Collinwood, Ohio.
- RAILWAY SUPPLY MANUFACTURERS' ASSOC.—J. D. Conway, 2135 Oliver bldg., Pittsburgh, Pa. Meetings with M. M. and M. C. B. Assocs.
- RAILWAY TEL. & TEL. APPLIANCE ASSOC.—W. E. Harkness, 284 Pearl St., New York. Meetings with Assoc. of Ry. Teleg. Sups.
- RICHMOND RAILROAD CLUB.—F. O. Robinson, Richmond, Va.; 2d Monday except June, July and August.
- ROADMASTERS' AND MAINTENANCE OF WAY ASSOCIATION.—L. C. Ryan, C. & N. W., Sterling, Ill.
- ST. LOUIS RAILWAY CLUB.—B. W. Frauenthal, Union Station, St. Louis, Mo.; 2d Friday in month, except June, July and Aug., St. Louis.
- SIGNAL APPLIANCE ASSOCIATION.—F. W. Edmonds, 3868 Park Ave., New York. Meeting with annual convention Railway Signal Association.
- SOCIETY OF RAILWAY FINANCIAL OFFICERS.—C. Nyquist, La Salle St. Station, Chicago.
- SOUTHERN ASSOCIATION OF CAR SERVICE OFFICERS.—E. W. Sandwich, A. & W. P. Ry., Montgomery, Ala. Annual meeting, October 16, 1913, Atlanta, Ga.
- SOUTHERN & SOUTHWESTERN RAILWAY CLUB.—A. J. Merrill, Grant bldg., Atlanta, Ga.; 3d Thurs., Jan., March, May, July, Sept., Nov., Atlanta.
- TOLEDO TRANSPORTATION CLUB.—J. G. Macomber, Woolson Spice Co., Toledo, Ohio; 1st Saturday, Toledo.
- TRACK SUPPLY ASSOCIATION.—W. C. Kidd, Ramapo Iron Works, Hillsburn, N. Y. Meeting with Roadmasters' and Maintenance of Way Association.
- TRAFFIC CLUB OF CHICAGO.—W. H. Wharton, La Salle Hotel, Chicago.
- TRAFFIC CLUB OF NEW YORK.—C. A. Swope, 290 Broadway, New York; last Tuesday in month, except June, July and August, New York.
- TRAFFIC CLUB OF PITTSBURGH.—D. L. Wells, Erie, Pittsburgh, Pa.; meetings monthly, Pittsburgh.
- TRAFFIC CLUB OF ST. LOUIS.—A. F. Versen, Mercantile Library building, St. Louis, Mo. Annual meeting in November. Noonday meetings October to May.
- TRAIN DESPATCHERS' ASSOCIATION OF AMERICA.—J. F. Mackie, 7122 Stewart Ave., Chicago. Next convention, June 16, Jacksonville, Fla.
- TRANSPORTATION CLUB OF BUFFALO.—J. M. Sells, Buffalo; first Saturday after first Wednesday.
- TRANSPORTATION CLUB OF DETROIT.—W. R. Hurley, L. S. & M. S., Detroit, Mich.; meetings monthly.
- TRAVELING ENGINEERS' ASSOCIATION.—W. O. Thompson, N. Y. C. & H. R., East Buffalo, N. Y. Next meeting, Chicago.
- UTAH SOCIETY OF ENGINEERS.—Fred D. Ulmer, Oregon Short Line, Salt Lake City, Utah; 3rd Friday of each month, except July and August.
- WESTERN CANADA RAILWAY CLUB.—W. H. Rosevear, P. O. Box 1707, Winnipeg, Man.; 2d Monday, except June, July and August, Winnipeg.
- WESTERN RAILWAY CLUB.—J. W. Taylor, Old Colony building, Chicago; 3d Tuesday of each month, except June, July and August.
- WESTERN SOCIETY OF ENGINEERS.—J. H. Warder, 1735 Monadnock Block, Chicago; 1st Monday in month, except July and August, Chicago.

# Traffic News.

The Sunset-Central Lines are to be added to the list of railroads which print a monthly bulletin for the benefit of station agents. The first number, dated September 1, has been issued by the Traffic Department of the Sunset-Central Lines, Houston, Tex.

The Federal Court has ordered the Central of Georgia and the Western of Alabama to establish passenger rates in the State of Alabama, beginning October 20, on the basis of 2½ cents a mile, in accordance with the order of the state authorities. The present fares are based on a rate of three cents a mile.

A company has been organized in Augusta, Ga., to operate a line of steel barges on the Savannah river from Augusta to Savannah. The company was formed as a result of interviews with Col. Kingman, United States engineer, in which he warned the business interests of Augusta that unless more use could be made of the Savannah river between Savannah and that city, federal appropriations for its improvement probably would be cut off.

The annual report of the United States Express Company for the year ended June 30, last shows gross earnings of \$21,620,710, an increase of \$701,727 over the preceding year. Because of greater operating expenses, however, there was an operating deficit for the year of \$109,512, as compared with a deficit the previous year of \$61,012. After adding other income and deducting \$24,280 for miscellaneous expenses there remained a balance applicable to dividends of \$232,038.

At a meeting of the Transcontinental Passenger Association, held in Chicago last week, the question of rates to the Panama Exposition to be held in San Francisco in 1915 was deferred, after considerable discussion, to be considered at the next meeting, in San Francisco, in March. It was decided that whatever rate should be made for the Exposition would be the lowest rate made that year for conventions on the Pacific coast. A new standing committee was appointed to which will be referred controversies regarding rates and divisions, and the question of proposed changes of clergy fares was referred to a committee. A recommendation was adopted in favor of abolishing the practice of parking cars during conventions.

The Department of Agriculture is making tests and inspections of 10 carloads of dried fruit being transported from Los Angeles to New York, Washington and other cities of the East, to furnish data for the Bureau of Chemistry to guide the Bureau in drafting regulations for the new net weight law, which requires that the quantity of the contents be plainly indicated on the outside of every package of food. The tests with the dried fruit are to determine the amount of shrinkage which takes place in transit from the Pacific to the Atlantic Coast. Certain products will lose weight when shipped from where the climate is moist to a dry place. Some crates of macaroni recently shipped to Denver and Arizona, lost weight, while those sent to New Orleans, San Francisco and Seattle gained, owing to moisture in the air.

In the United States Court for the Southern District of Texas, at Galveston, October 1, Judge Waller T. Burns presiding, after an all day hearing made permanent the temporary injunction granted by Judge Burns at Houston, restraining ten steamship companies and agents from making certain notations on bills of lading for cotton to be exported. Under the agreed judgment entered, bills of lading for cotton must hereafter bear printed on them as a part of the agreement the words "received in apparent good order — bales of cotton baled in the usual American method," and where other damage is noted, the bills must bear in writing on their face a description of the specific damage and the number of bales so damaged. The injunction restrains the use of such notations as "not thoroughly covered," "subject to damage," "soiled more or less," "insufficient covering."

## Car Balance and Performance.

Arthur Hale, chairman on the committee on relations between railroads of the American Railway Association, in presenting

CAR BALANCE AND PERFORMANCE IN JUNE, 1913.

	New England	N. Y., N. J., Del., Md., Eastern Pa.	Ohio, Ind., Mich., Western Pa.	Va., W. Va., No. and So. Carolina.	Ky, Tenn., Miss., Ala., Ga., Fla.	Iowa, Ill., Wis., Minn.	Mont., Wyo., Neb., Dakotas.	Kan., Colo., Okla., Mo., Ark.	Texas, La., New Mex.	Ore., Idaho, Nev., Cal., Ariz.	Canadian Lines.	Grand Total.
Revenue freight cars owned.....	89,845	689,701	218,603	189,287	172,793	438,498	17,970	145,246	30,574	136,113	136,113	2,265,431
Average number of system cars on line.....	42,841	380,887	130,262	100,614	84,783	304,022	5,960	76,088	20,064	71,149	94,300	1,310,970.
Railway-owned cars: Average foreign on line....	49,284	314,723	122,055	74,930	70,439	147,915	8,275	59,191	19,571	40,376	41,801	948,560
Total Railway-owned cars on line.....	92,125	695,610	252,317	175,544	155,222	451,937	14,235	135,279	39,635	111,525	136,101	2,259,530
Excess.....	2,280	5,909	33,714	+13,743	+17,571	13,439	+3,735	+9,967	9,061	+25,276	+12	+5,901
Per cent. of cars on line to total owned:												
Home.....	48	55	59	53	49	69	33	52	66	52	69	58
Foreign.....	55	46	56	40	41	34	46	37	64	30	31	42
All railroads.....	103	101	115	93	90	103	79	89	130	82	100	100
Private cars on line.....	3,744	36,957	10,728	4,963	10,136	15,328	1,609	8,561	3,907	12,907	2,717	111,557
Total, all cars on line.....	95,869	732,567	263,045	180,507	165,358	467,265	15,844	143,840	43,542	124,432	138,818	2,371,087
No. of freight engines owned.....	664	5,888	9,989	5,850	11,070	5,437	7,890	9,006	7,773	6,339	4,444	7,009
Average cars on line per freight engine owned.....	1,454	10,486	3,173	3,182	2,934	7,103	509	2,924	877	2,829	2,272	38,009
Total freight-car mileage.....	66	70	83	83	56	31	31	49	50	64	61	82
Average mileage per car per day.....	55,589,318	532,818,456	170,436,412	142,272,790	132,207,286	321,868,374	22,660,561	93,354,307	33,801,458	111,464,299	103,826,093	1,720,299,354
Per cent. loaded mileage.....	19.3	24.2	21.6	26.3	27.0	22.8	49.2	22.7	25.9	29.9	24.9	24.3
Ton-miles of freight, including company freight.....	73.3	66.5	68.1	65.2	69.0	71.8	78.3	69.7	65.8	70.2	74.0	69.0
Average ton-miles, including company freight:												
Per car-mile.....	11.6	16.5	17.7	16.1	14.2	14.7	17.7	13.8	11.8	14.6	14.7	15.5
Per loaded car-mile.....	15.8	24.8	26.0	24.7	20.7	20.1	22.6	19.8	17.9	20.9	19.9	22.5
Per car per day.....	224	400	383	423	385	334	872	314	305	437	368	377
Gross freight earnings.....	6,658,273	51,138,061	15,685,117	12,422,869	11,807,038	34,156,041	2,905,808	10,730,755	3,326,718	16,219,828	10,437,966	175,488,474
Average daily earnings: Per car owned.....	2.47	2.47	2.39	2.19	2.28	2.60	5.39	2.41	2.80	3.95	2.56	2.58
Per railroad car on line.....	2.41	2.45	2.07	2.36	2.54	2.52	6.80	2.71	2.80	4.85	2.56	2.59
All cars on line.....	2.32	2.33	1.99	2.29	2.38	2.44	6.11	2.56	2.55	4.35	2.51	2.47

\* Denotes deficiency.



statistical bulletin No. 154, covering car balances and performances for June says:

The miles per car per day for June were 24.3, compared with 25.0 in May. This figure for June, 1912, was 24.1.

Ton miles per car per day for June were 377, compared with 387 in May. This is an increase of 3.01 per cent. over the figure for June, 1912, which was 366.

**Making a Date with the Public.**

The Long Island Railroad, desiring to give patrons the best service possible, and to meet all reasonable criticisms, announces that a special committee of officers has been appointed to meet patrons, who have suggestions or criticisms to make, regularly on the first and third Wednesdays of each month at 9 a. m., in the office of the General Superintendent at Jamaica. It is re-

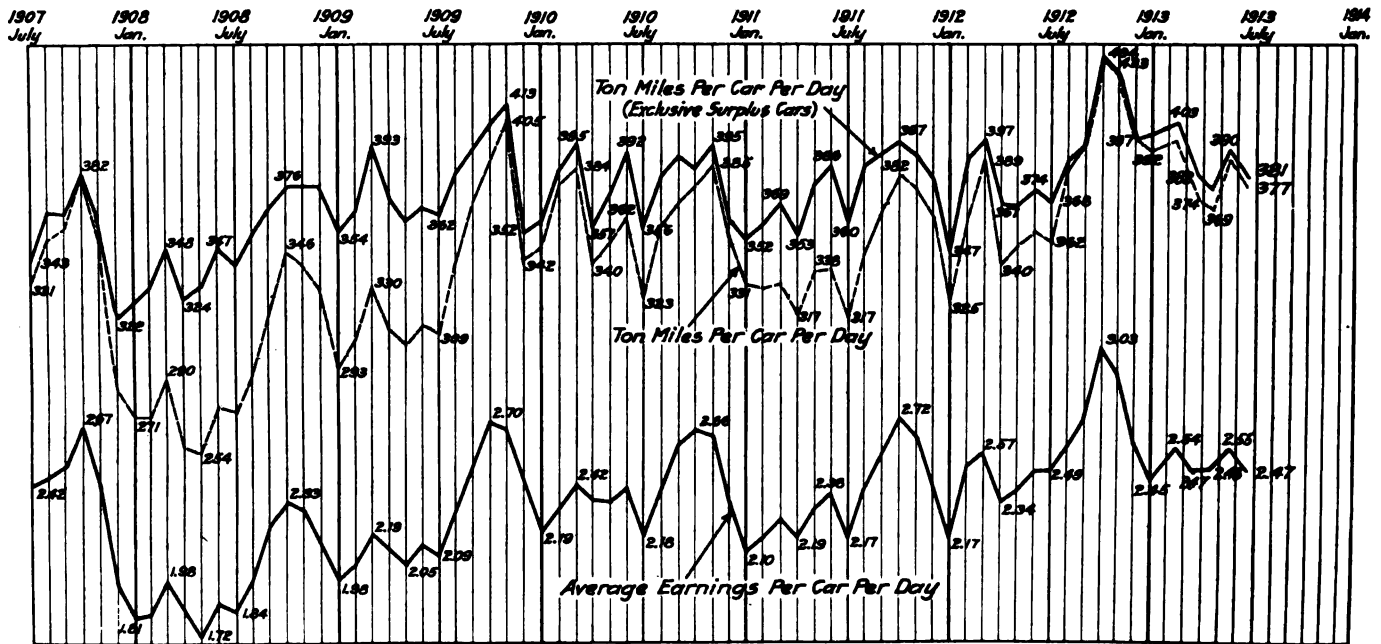
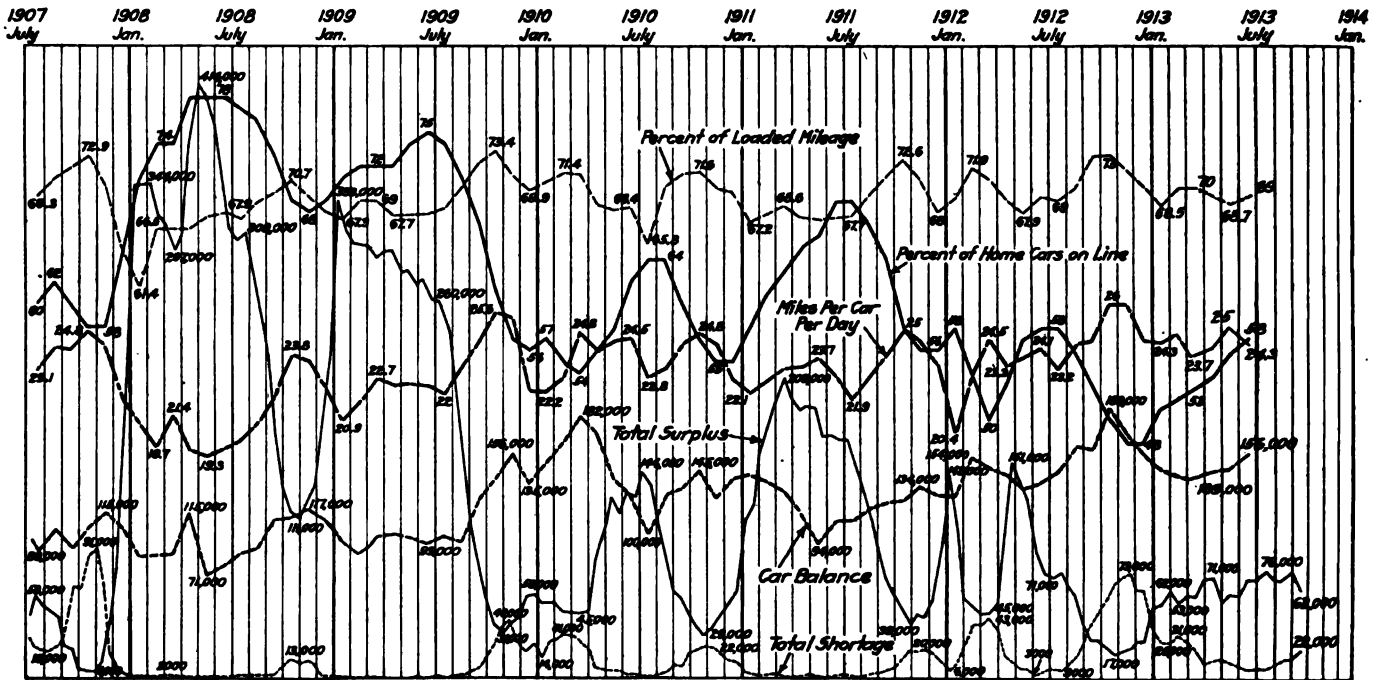

**Freight Car Mileage, Earnings and Performance, 1907 to 1913.**

The proportion of home cars on line increased two points to 58 per cent. in June, 1913. This figure was the same in June, 1912.

The per cent. of loaded car mileage increased from 68.7 per cent. in May to 69.0 per cent. in June, 1913. This figure for June, 1912, was 69.3 per cent.

The average earnings per car per day for all cars on line decreased 8 cents to \$2.47 in June, 1913. This figure for June, 1912, was \$2.49.

The accompanying table gives the car balance and performance in the months covered by the report, and the diagram shows car earnings and car mileage and different car performance figures monthly from July, 1907.

quested that suggestions or criticisms be made in writing and that they be sent in at least three days prior to the date of the meeting, and that the writer or a representative be present at the meeting.

**Revenues and Expenses of Large Roads for August.**

The following figures were compiled by the Interstate Commerce Commission from monthly reports of operating revenues and expenses of large steam roads for the month of August, 1913, received up to October 3. No reports are included for roads whose operating revenues for the year ended June 30, 1913, did not reach \$1,000,000. The figures are compiled as re-

dered and should not be considered final, inasmuch as close scrutiny of the reports may lead to their modification before acceptance.

The commission has suspended from October 3, until April 3, the item in a supplement to the tariff of the Chicago & North Western, which contains advanced rates for the transportation

REVENUES AND EXPENSES OF LARGE STEAM ROADS.

Item.	United States.		Eastern District.		Southern District.		Western District.	
	1913.	1912.	1913.	1912.	1913.	1912.	1913.	1912.
Number of reports included...	103		48		26		29	
Average number of miles operated	136,888.97	135,519.68	38,638.90	38,388.72	37,213.24	37,045.02	61,036.83	60,085.34
Total operating revenues	\$178,821,018	\$176,704,379	\$89,178,211	\$87,811,898	\$33,383,111	\$32,821,915	\$56,259,696	\$56,070,566
Total operating expenses	123,552,166	113,806,583	61,761,457	56,002,883	24,561,070	23,076,898	37,229,639	34,726,807
Net operating revenue	55,268,852	62,897,791	27,416,754	31,809,015	8,822,041	9,745,017	19,030,057	21,343,759
Revenue per mile	1,306	1,303	2,308	2,287	897	886	922	933
Expenses per mile	902	839	1,598	1,458	660	623	610	578
Net revenue per mile	404	464	710	829	237	203	312	355
MONTH OF AUGUST.								
TWO MONTHS ENDING WITH AUGUST.								
Average number of miles operated	136,879.06	135,403.00	38,641.95	38,384.87	37,212.26	37,034.34	61,024.35	59,983.79
Total operating revenue	\$350,493,550	\$339,704,968	\$175,017,208	\$168,685,216	\$65,537,598	\$63,617,447	\$109,938,744	\$107,402,305
Total operating expenses	244,727,950	223,907,601	122,586,430	109,815,375	48,532,628	45,913,350	73,608,892	68,178,876
Net operating revenue	105,765,600	115,797,367	52,430,778	58,869,841	17,004,970	17,704,097	36,329,852	39,223,429
Revenue per mile	2,561	2,509	4,529	4,395	1,761	1,718	1,802	1,791
Expenses per mile	1,738	1,654	3,172	2,861	1,304	1,240	1,205	1,137
Net revenue per mile	773	855	1,357	1,534	457	478	596	654
COMPARATIVE FIGURES BASED ON ALL ROADS HAVING REVENUES ABOVE \$1,000,000 PER ANNUM REPORTING FOR AUGUST, 1912.								
For the month:								
Average number of miles operated	1912.	1911.	1912.	1911.	1912.	1911.	1912.	1911.
Revenue per mile	220,463.60	218,224.80	57,932.46	57,483.54	41,471.67	41,078.29	121,059.47	119,662.97
Expenses per mile	\$1,217	\$1,119	\$2,117	\$1,928	\$892	\$844	\$898	\$824
Net revenue per mile	780	726	1,351	1,233	632	583	558	531
For two months:	437	393	766	695	260	261	340	293
Average number of miles operated	220,282.34	218,173.51	57,929.16	57,474.64	41,458.02	41,071.96	120,895.16	119,626.91
Revenue per mile	\$2,336	\$2,144	\$4,049	\$3,681	\$1,730	\$1,631	\$1,723	\$1,581
Expenses per mile	1,534	1,424	2,648	2,417	1,255	1,144	1,096	1,044
Net revenue per mile	802	720	1,401	1,264	475	487	627	537

Car Location.

The accompanying table, which was taken from bulletin No. 10 of the American Railway Association, gives a summary of freight car location by groups on September 1, 1913.

of condensed or evaporated milk when shipped in glass or stone-ware packed in barrels, boxes or crates; in bulk in kits, kegs or barrels; in cans, jacketed, or in railroad shipping cans, straight or mixed carloads, between points in Illinois and Wisconsin.

CAR LOCATION ON SEPTEMBER 1, 1913.

	New England.	N.Y., N.J., Del., Md., Pa.	Ohio, Ind., Mich., Pa.	Ill., Va., W. Va., No. & So. Carolina.	Ky., Tenn., Miss., Ala., Ga., Fla.	Iowa, Ill., Wis., Minn.	Mont., Wyo., Neb., Dakotas.	Kans., Colo., Mo., Ark.	Texas, La., New Mexico.	Oregon, Idaho, Nev., Cal., Ariz.	Canadian Lines.	Grand Total.
Total Cars Owned	88,036	683,033	272,475	203,698	165,342	479,896	16,733	130,894	30,371	133,314	139,299	2,343,091
Home Cars on Home Roads	44,793	396,062	105,657	108,115	83,596	332,662	5,433	66,537	13,947	77,772	95,913	1,330,487
Home Cars on Foreign Roads	43,243	286,971	166,818	95,583	81,746	147,234	11,300	64,357	16,424	55,542	43,386	1,012,604
Foreign Cars on Home Roads	48,645	300,962	209,556	73,081	68,059	190,419	9,369	67,374	24,140	54,773	42,315	1,088,693
Total Cars on Line	93,438	697,024	315,213	181,196	151,655	523,081	14,802	133,911	38,087	132,545	138,228	2,419,180
Excess or Deficiency	5,402	13,991	42,738	*22,502	*13,687	43,185	*1,931	3,017	7,716	*769	*1,071	76,089
Surplus	1,261	5,046	1,416	6,015	1,934	15,925	453	9,977	1,656	14,585	15,268	73,576
Shortage	387	1,347	2,554	4,269	2,149	1,826	62	413	79	694	1,459	15,239
Shop Cars—												
Home Cars in Home Shops	6,521	41,580	21,543	13,452	15,827	25,492	658	10,196	2,702	6,063	4,663	148,697
Foreign Cars in Home Shops	1,164	8,215	6,840	1,990	2,028	4,931	484	2,183	980	2,347	423	31,585
Total Cars in Shops	7,685	49,795	28,383	15,442	17,855	30,423	1,142	12,379	3,682	8,410	5,086	180,282
Per Cent. to Total Cars Owned—												
Home Cars on Home Roads	50.88	57.98	38.77	53.08	50.56	69.32	32.47	50.83	45.92	58.33	68.85	56.78
Total Cars on Line	103.48	102.05	115.59	88.95	91.72	109.00	88.46	100.81	125.41	99.42	99.23	103.25
Home Cars in Home Shops	7.41	6.09	7.91	6.60	9.57	5.65	3.93	7.79	8.89	4.55	3.35	6.42
Foreign Cars in Home Shops	.99	1.20	2.51	.98	1.97	1.09	2.89	1.53	3.23	1.76	.30	1.37
Total Cars in Shops	8.40	7.29	10.42	7.58	11.54	6.74	6.82	9.32	12.12	6.31	3.65	7.79

\*Denotes deficiency.

INTERSTATE COMMERCE COMMISSION.

The St. Louis Cotton Exchange has filed a complaint with the Interstate Commerce Commission charging discrimination against the St. Louis market in the rates on cotton from Oklahoma points.

Frank McManamy, assistant chief inspector of boilers, under the Interstate Commerce Commission, has been nominated by President Wilson for the position of chief inspector, in place of J. F. Ensign, deceased.

The commission has suspended from October 4 until April 4 the items in a supplement to Agent F. A. Leland's and Agent Eugene Morris' tariffs which proposed to advance rates on packing house products originating at or destined to points in Arkansas, Louisiana and Oklahoma by the withdrawal of fourth class rating thereon.

The commission has suspended from October 8 until April 8 the schedules in supplements to certain tariffs which contain advanced rates for the transportation of brooms, C. L., from Chicago and Peoria, Ill., St. Paul, Minn., etc., Missouri River points and points in Mississippi River territory to Denver, Col., and points taking same rates.

The commission has suspended from October 3, until April 3, the item in a supplement to the tariff of the Chicago & North Western, which advances the rate on paper, c. l., from Milwaukee and Manitowoc, Wis., to Kaukauna, Wis., which rate is one of the factors employed in making through rates to the latter point from certain points in the East.

The commission has suspended until January 28, the items in certain tariffs which contain proposed advances in rates on lumber in carloads from San Francisco and other points in California to points in Texas and New Mexico north of El Paso,

Texas. The present rate to most of these points is 40 cents, and the proposed rate is 50 cents per 100 lbs.

The commission has suspended from October 10 until January 29 the supplement to the tariff of the Carolina, Clinchfield & Ohio, which proposed to effect advances in class and commodity rates from St. Paul, Va., to Atlanta, Ga., and other southern points similar to those contained in schedules of other carriers, the operation of which was suspended by an order previously entered in the same docket.

The commission has suspended from October 1 until January 29 the schedules contained in certain tariffs, which proposed advances in class and commodity rates from Richmond, Norfolk, Lynchburg, Roanoke, Va., and other points taking Virginia cities rates to Vicksburg, Miss.; Montgomery, Ala.; Macon, West Point, Atlanta, Ga., and other southern points. The advance in class rates amount to as much as 7 cents per 100 lbs. in some instances.

The commission has suspended from October 2 until January 30 the item in a supplement to Agent F. A. Leland's tariff, which contains proposed advances in rates on cotton seed hulls, in carloads, from Beaumont, East Beaumont and Houston, Tex., to New Orleans and other points in Louisiana located on the New Orleans, Texas & Mexico. These advances range from one-half to four and a half cents per 100 lbs. The present rate to New Orleans, for example, is 8.5 cents and the proposed rate is 13 cents per 100 lbs.

The commission has suspended until January 28 certain tariff items. Under present tariff provisions gasoline engines, and parts, may be included with shipments of wind mills and wind mill parts and forwarded in mixed carloads at a commodity rate of \$1.50 per 100 lbs., from Chicago to San Francisco and other California terminals. The suspended items propose to continue in effect the rate above stated upon shipments of wind mills and wind mill parts, in carloads, but do not permit gasoline engines to be forwarded in the same car at that rate. The carload rate on the latter from Chicago is \$1.40 per 100 lbs., and the less carload rate is \$3.40 per 100 lbs. Shipments from other points would be effected in a like manner.

The commission has suspended from September 30 until January 28 certain items in certain tariffs. Transcontinental tariffs naming commodity rates on shipments of butter, eggs and other dairy products from points in Nebraska, Kansas and other states to the Pacific coast provide that such rates include the privilege of concentration and storage under rules and regulations published in tariffs of the individual lines parties to such commodity rates. The suspended items provide for the withdrawal of this privilege, which would result in material advances through the application of local rates from points of origin to the concentration or storage point plus the tariff rate to final destination.

#### STATE COMMISSIONS.

The California Railroad Commission has issued an order that when freight cars are loaded to physical capacity with any article for which a carload rate is provided, except articles with a minimum carload weight of 24,000 lbs. or less, charges shall be based only on actual weight.

The railroad commissioners of South Dakota have issued an order requiring that on all shipments of freight passing over two or more roads, the rate on each road must be not more than 80 per cent. of the local rate; and at junction points where there are track connections there must be no charge for switching.

Edward F. Boyle has been appointed by the Public Service Commission of New York, for the First district, as Special Examiner, at an annual salary of \$6,000. Mr. Boyle is a lawyer and accountant, and until recently had been chief of the executive staff in the office of the president of the board of aldermen. Prior to that time he had held various positions in the office of the Commissioner of Accounts for New York City.

Following a hearing at Chicago on October 1, the Illinois Railroad and Warehouse Commission announced its intention of ordering a schedule of rules governing switching rates and practices to apply in the state generally, with the exception of Chicago and East St. Louis, which have special rules. At

a conference between representatives of the railways and the shippers at the hearing it was agreed to appoint a committee of ten members—five shippers and five railway men—to formulate a tentative set of rules to be submitted to the commission.

The Oklahoma Corporation Commission has ordered the Wichita Falls & Northwestern to put two-cent passenger fares in effect on its line by October 15 for a four months' test. The company at a hearing before the commission objected on the ground that the two-cent rate would not yield a compensatory revenue, and a question was raised as to the relations of the company to the Missouri, Kansas & Texas. The commission held that the line should be considered as part of the Missouri, Kansas & Texas instead of as an independent line.

The New Jersey public utility commissioners have refused to approve a proposed 99-year lease of the property and franchises of the Lehigh Valley Railroad Company of New Jersey to the Lehigh Valley Railroad Company of Pennsylvania. The New Jersey company, either of itself or through subsidiary corporations, owns about 94 miles of railroad in New Jersey, operated by the Lehigh Valley, which owns all of the stock of the New Jersey corporation. The commissioners saw no objection to the approval of the lease, but they held that, under the law, they had no power to approve it.

The Supreme Court of Oklahoma has sustained an order of the Corporation Commission of that state, requiring ticket windows at railroad stations to be opened for a period of one hour before the departure of passenger trains. It appears that this decision refers to a case that arose in 1910. The roads of the state changed from the two to the three-cent passenger fare at midnight, March 9, 1910. A train of the Atchison, Topeka & Santa Fe was due at Avard at 12:20 a. m., and had the commission's order been obeyed passengers would have been able to purchase tickets at the two-cent rate; but the ticket office was not opened until ten minutes before the train was due to leave, and, according to the complaint, passengers were forced to purchase at the three-cent rate. The commission fined the Santa Fe \$500, and on the company's appeal the commission was sustained.

#### COURT NEWS.

##### Oregon Rate Law Declared Invalid.

The Oregon rate law adopted by the people of the state under the initiative at the general election last November, which prescribed a percentage relationship between the classification ratings of freight and minimum carload weights, has been declared unconstitutional by three judges of the United States court at Portland, Oregon. A temporary injunction issued several months ago on application of the Hill and Harriman lines was made permanent. The decision was given by Judge Wolverton, who declared the act was not only violative of the right of the carrier to manage its own affairs and exercise its own judgment respecting the spread between carload and less than carload rates, but would compel the carriers in many instances to accept unreasonably low rates in order to comply with its provisions and avoid criminal prosecution. The court also declared that the first three sections of the act are irreconcilable and wholly incongruous, and that the act is an attempt under the guise of the exercise of the police power of the state to make exceptions in favor of particular places and communities.

"We do not deny," said the court, "that the legislature, the people, or the railroad commission may determine and adopt a reasonable spread as applied to specific commodities and for the protection of given localities; but that is a very different question from one arising from an edict that a certain definite and rigid spread shall be applied to all commodities, whatsoever may be their kind or character, origin of shipment or destination. Indeed, the act would seem to defeat itself. It will either compel the carrier to accept unreasonably low rates on carloads lots as respects some commodities, which would be unjust and confiscatory, or to fix unreasonably high rates on less than carload lots, which the law will not permit, in order to adjust the carload rates within the maximum relative rates for minimum carload weights; or it might constrain the carrier in order to afford the public a very low rate on commodities that would justify it to carry the same commodities less than carload at an unreasonably low rate."

REVENUES AND EXPENSES OF RAILWAYS.

MONTH OF AUGUST, 1913.

Name of road.	Average mileage operated during period.	Operating revenues.			Operating expenses.			General.	Total.	Net operating revenue (or deficit).	Outside operations, net.	Taxes.	Operating income (or loss).	Increase (or decr.) comp. with last year.
		Freight.	Passenger.	Total, inc. misc.	Maintenance of way and structures, equipment.	Traffic.	Transportation.							
Alabama & Vicksburg	143	\$91,655	\$46,958	\$150,563	\$21,499	\$36,267	\$3,597	\$52,279	\$5,601	\$119,243	-\$353	\$7,450	\$23,517	-\$8,101
Arizona & New Mexico	109	72,694	9,454	82,148	14,515	85,733	671	15,886	2,631	41,924	.....	3,400	40,414	16,145
Arizona Eastern	367	154,760	37,766	203,788	29,384	32,533	2,140	64,780	11,740	140,577	63,211	11,396	51,872	39,805
Atchison, Topeka & Santa Fe	8,358	5,372,767	2,181,847	8,143,757	1,286,654	1,433,471	167,294	2,223,690	191,497	5,302,606	2,341,151	376,189	2,464,962	78,616
Atlanta, Birmingham & Atlantic	645	168,435	66,705	254,853	44,389	47,839	3,271	102,877	10,607	218,633	36,220	14,337	21,883	12,265
Atlantic & St. Lawrence	167	83,230	38,120	131,830	24,777	17,922	3,922	53,986	53,986	103,979	27,851	10,157	17,694	49,303
Atlantic City	647	1,551,920	353,060	441,328	24,877	13,101	7,156	154,113	1,690	200,337	309,521	9,000	277,366	43,311
Atlantic Coast Line	4,617	1,455,920	695,699	2,331,716	435,852	472,037	52,634	956,175	105,497	2,022,195	309,521	132,000	1,777,521	248,950
Bangor & Aroostook	631	148,202	67,280	228,419	44,583	39,245	2,438	95,617	10,472	179,491	48,948	9,757	39,325	19,316
Bell, Ky. Co. of Chicago	21	.....	.....	253,964	20,328	.....	559	99,844	5,661	158,306	95,638	9,756	85,902	25,096
Bessemer & Lake Erie	204	961,809	61,397	1,036,433	85,910	154,656	9,527	225,797	11,218	487,108	549,325	38,000	511,325	59,294
Boston & Maine	2,252	2,355,599	1,905,540	4,580,644	608,423	641,641	34,279	1,812,221	95,142	3,193,706	1,386,938	166,221	2,526,789	152,727
Buffalo & Susquehanna Railroad	253	140,675	10,158	154,672	28,099	24,209	1,100	51,350	5,885	110,643	44,029	2,200	108,429	13
Buffalo & Susquehanna Railway	91	38,494	15,629	57,070	11,216	26,519	473	22,076	3,223	63,507	6,437	1,600	7,898	3,092
Buffalo, Rochester & Pittsburgh	576	897,037	147,959	1,084,384	148,700	188,816	12,602	353,673	19,027	722,818	361,566	18,000	344,188	17,362
Butte, Anaconda & Pacific	90	90,888	28,827	129,862	18,437	13,389	810	44,561	4,240	85,490	44,723	2,250	42,127	24,544
Canadian Pacific Lines in Maine	233	42,953	24,245	76,164	31,436	17,838	6,304	35,683	4,225	91,037	14,873	11,000	25,872	10,634
Carolina, Clinchfield & Ohio	248	222,424	24,314	252,245	18,325	28,204	6,755	43,968	8,602	105,854	146,391	9,250	137,141	1,653
Carolina, Clinch & Ohio Ry. Co. of S. C.	18	11,677	.....	14,154	704	.....	1,195	2,552	419	5,158	8,906	7,750	8,246	1,583
Central of Georgia	1,924	573,417	356,979	1,002,793	181,316	243,360	32,062	374,194	39,769	870,701	132,092	50,370	89,238	104,446
Central New England	270	262,186	40,120	312,940	53,192	32,745	1,038	81,660	3,980	172,557	140,383	10,500	130,186	28,140
Charleston & Western Carolina	341	112,251	36,105	155,237	31,224	32,778	3,376	62,398	4,518	125,294	29,943	5,000	24,943	22,284
Chesapeake & Ohio Lines	2,343	2,466,718	642,170	3,244,635	358,413	603,290	57,647	964,559	81,702	2,065,611	1,179,024	109,960	1,079,853	73,355
Chicago & Erie	270	355,256	71,344	473,942	104,975	112,004	19,700	244,470	11,501	492,650	18,708	12,895	40,997	32,404
Chicago, Burlington & Quincy	9,129	6,021,798	2,334,514	9,059,969	1,185,855	1,422,075	162,460	2,547,307	195,064	5,512,761	3,547,208	304,275	3,233,920	194,373
Chicago, Indiana & Southern	359	315,127	33,818	361,301	129,716	7,012	7,012	119,192	9,913	323,193	38,108	15,283	24,074	38,712
Chicago Junction	12	5,275,305	1,953,838	7,870,612	1,239,156	6,260	1,454	88,250	3,525	116,499	62,337	2,511	59,826	8,117
Chicago, Milwaukee & St. Paul	9,600	.....	.....	1,300,649	1,300,649	.....	185,355	2,730,335	161,517	5,617,014	2,233,598	399,377	1,903,603	1,043,639
Chicago, Peoria & St. Louis	255	68,971	38,995	142,238	20,216	26,316	6,617	64,585	5,056	136,424	5,804	4,800	1,004	33,774
Chicago, Rock Island & Gulf	477	168,167	62,113	248,595	27,005	35,293	10,386	94,521	7,667	174,872	73,723	7,935	64,726	4,269
Chicago, Rock Island & Pacific	7,525	3,764,602	1,955,629	6,077,773	996,991	881,515	160,623	2,249,950	142,160	4,431,239	1,645,834	280,481	1,353,330	445,375
Chicago, St. Paul, Minneapolis & Omaha	1,747	887,189	521,225	1,499,676	301,988	198,591	32,676	569,758	82,901	1,135,214	364,462	74,877	294,422	40,865
Chicago, Terre Haute & Southwestern	3,62	150,920	20,829	175,923	29,270	38,530	2,889	52,700	3,202	132,340	43,583	11,500	32,039	30,251
Colorado & Midland	338	121,810	39,959	171,210	37,262	36,924	8,882	67,549	5,554	156,171	15,039	8,000	6,891	13,668
Colorado & Southern	1,131	562,645	228,339	830,366	115,522	179,274	13,508	219,423	20,973	548,700	281,666	30,675	250,182	79,179
Delaware, Lackawanna & Western	959	2,511,859	907,102	3,636,234	560,322	520,505	69,607	1,036,843	70,544	2,257,821	1,378,843	165,000	1,253,567	41,556
Denver & Rio Grande	2,585	1,488,232	641,907	2,329,604	461,352	300,299	44,324	630,434	53,105	1,579,714	659,890	87,800	383,680	9,484
Detroit & Mackinac	411	1,065,714	38,421	1,139,243	120,777	121,561	2,340	39,223	2,530	68,531	68,531	8,497	50,021	15,004
Detroit & Toledo Shore Line	79	129,117	.....	129,558	16,317	.....	3,438	38,315	5,394	65,050	64,509	5,000	58,609	15,994
Detroit, Grand Haven & Milwaukee	191	115,500	72,500	214,207	37,602	27,807	5,519	99,737	5,547	176,612	37,595	3,000	34,178	28,061
Detroit River Tunnel	2	.....	.....	106,274	2,693	3,011	.....	8,777	37	14,518	91,756	6,000	85,756	1,612
Detroit, Toledo & Ironton	441	117,741	17,707	146,240	45,063	63,133	2,295	75,743	5,472	191,706	45,466	5,700	51,165	89,169
Duluth & Iron Range	272	1,267,662	26,131	1,212,160	107,145	107,145	1,148	227,946	10,743	426,563	79,651	65,307	373,621	88,068
Duluth, Missabe & Northern	356	1,267,662	38,952	1,316,136	92,082	107,651	2,937	191,060	11,311	405,041	911,095	73,551	844,263	136,935
Duluth, South Shore & Atlantic	627	202,479	128,043	354,783	82,214	37,436	8,146	112,995	16,749	257,538	97,245	18,000	82,436	9,925
Duluth, Winnipeg & Pacific	166	115,157	24,454	141,811	15,061	15,061	1,560	47,827	5,809	101,796	40,015	7,091	32,924	15,278
El Paso & Southwestern Co.	982	538,794	99,245	688,933	121,969	95,813	14,721	182,477	25,630	440,569	238,384	37,500	192,003	56,177
Elgin, Joliet & Eastern	802	1,065,714	.....	1,139,243	190,356	219,799	4,931	310,722	19,203	745,193	394,582	27,650	366,402	151,529
Erie	1,988	3,406,277	1,070,762	4,850,064	702,348	813,369	103,974	1,550,532	98,075	3,266,318	1,531,746	138,547	1,389,475	427,704
Florida & Cripple Creek	87	89,416	43,940	135,712	18,481	8,292	2,724	30,384	4,220	64,301	71,411	1,679	69,732	43,305
Florida East Coast	642	136,100	108,435	279,689	83,606	64,614	5,126	128,817	9,686	291,849	12,160	20,000	33,911	43,305
Fort Worth & Denver City	578	264,273	176,190	461,077	65,406	82,771	6,972	161,790	14,271	331,210	169,797	18,200	111,771	44,031
Grand Rapids & Indiana	454	246,378	275,368	559,471	73,643	72,909	11,728	219,272	17,384	395,391	164,080	22,921	142,270	30,159
Grand Trunk Western	347	364,000	231,000	630,872	136,601	97,386	20,213	279,796	15,028	549,024	81,848	31,500	49,837	108,445
Great Northern	7,748	4,893,441	1,558,608	6,916,126	1,210,653	838,228	105,270	1,813,275	120,756	4,078,182	2,838,756	354,452	2,334,786	404,517
Gulf, Colorado & Santa Fe	1,596	820,702	314,327	1,201,309	215,648	190,766	24,639	419,243	11,733	882,021	319,378	.....	263,697	46,918
Hocking Valley	351	652,502	100,349	810,627	90,265	139,546	8,906	227,896	15,009	481,622	390,670	41,000	88,050	3,644
Illinois Central	4,763	3,602,522	1,319,120	5,686,002	861,320	1,322,126	108,151	1,960,483	135,007	4,382,177	2,588,835	264,000	991,805	67,167
Indiana Harbor Belt	105	615,659	227,718	894,346	39,217	35,000	2,871	120,993	7,499	205,380	72,773	3,500	69,387	20,683
International & Great Northern	1,160	615,659	227,718	894,346	120,528	114,119	27,036	356,534	29,947	484,164	246,182	20,000	224,762	1,308
Kanawha & Michigan	177	270,141	35,829	312,377	44,123	61,159	2,784	86,254	6,689	201,009	111,328	9,535	101,768	28,396
Kansas City Southern	827	661,711	172,370	915,549	118,007	118,007	25,489	283,178	30,395	337,091	378,458	40,013	338,445	9,615
Lake Erie & Western	906	412,125	103,688	546,895	94,365	128,960	13,759							

REVENUES AND EXPENSES OF RAILWAYS.

MONTH OF AUGUST, 1913—CONTINUED.

Table with columns: Name of road, Average mileage operated during period, Operating revenues (Freight, Passenger, Total, inc. misc.), Maintenance of Way and structures, Traffic, Transportation, General, Total, Outside operations, Net operating revenue, Taxes, Operating income, Increase (or decrease) comp. with last year.

REVENUES AND EXPENSES OF RAILWAYS.

TWO MONTHS OF FISCAL YEAR, 1914.

Table with columns: Name of road, Average mileage operated during period, Operating revenues (Freight, Passenger, Total), Maintenance of way and structures, Operating expenses (Traffic, Transportation), Net operating revenue, Total, Outside operations, Taxes, Operating income, Increase (or decrease) comp. with last year.

## Railway Officers.

### Executive, Financial and Legal Officers.

J. W. Newlean, comptroller of Wells Fargo & Company, with headquarters at Chicago, has been elected vice-president and comptroller in charge of the accounting and treasury departments.

Alexander Robertson, assistant to president of the Missouri Pacific at St. Louis, Mo., has been elected president of the American Refrigerator Transit Company, succeeding B. F. Bush.

E. N. Brown will continue as president of the National Railways of Mexico. Mr. Brown's resignation was tendered several months ago, but now has been withdrawn by him upon reaching a satisfactory agreement with the government.

E. H. Ryan has been elected president of the Muscatine North & South Railway, succeeding Charles Howard, resigned. Charles N. Voss has been elected vice-president and treasurer in place of D. H. McKee, resigned. H. B. Holbert, vice-president and traffic manager, has been elected secretary also, to succeed J. A. Coe, resigned. Mr. Holbert has been appointed auditor also, to succeed A. H. Kohlhammer, resigned. Headquarters Muscatine, Iowa.

William J. Cunningham, assistant professor of transportation of Harvard University, has been appointed vice-president's assistant of the New York, New Haven & Hartford, with office at New Haven, Conn. Professor Cunningham has been granted a two years' leave of absence from Harvard, but will not sever his connection with the university, and, in the meantime, will lecture at Harvard on transportation subjects. When J. H. Hustis, vice-president, becomes president of the New York, New Haven & Hartford, after the by-laws of the company have been changed, Professor Cunningham will become president's assistant.

### Operating Officers.

C. H. Fox has been appointed superintendent of the Sumpter Valley, with headquarters at Baker, Ore.

J. R. Mann has been appointed superintendent of transportation of the Detroit & Toledo Shore Line, with headquarters at Detroit, Mich.

J. A. Donahey, assistant engineer of the Akron, Canton & Youngstown, has been appointed superintendent and chief engineer, with office at Akron, Ohio, succeeding F. E. Bissell, resigned.

G. W. Briece, chief clerk in the office of superintendent of car service of the Missouri Pacific, has been appointed car accountant, with headquarters at St. Louis, Mo., in place of W. S. Crane, assigned to other duties.

F. W. Quimby, trainmaster of the Chicago, Indianapolis & Louisville at Lafayette, Ind., has been appointed train rule examiner, with headquarters at Lafayette. W. H. Fogg, chief train dispatcher, succeeds Mr. Quimby as trainmaster, and Howard E. Riggs takes the place of Mr. Fogg.

C. S. Millard, superintendent of the Michigan division of the Cleveland, Cincinnati, Chicago & St. Louis, at Wabash, Ind., has been appointed acting superintendent of the Chicago division, with headquarters at Indianapolis, Ind. T. J. Hayes succeeds Mr. Millard, and Edward Zeigler takes the place of Mr. Hayes as superintendent of terminals at Cincinnati, Ohio.

M. H. Broughton, trainmaster on the west end of the Cumberland division of the Baltimore & Ohio at Keyser, W. Va., has been promoted to supervisor of transportation, succeeding S. C. Wolfersberger. W. M. Haver, assistant trainmaster at Newark, Ohio, becomes trainmaster of the Monongah division at Clarksburg, W. Va., succeeding C. W. Van Horn, promoted.

James D. Tyter, superintendent of the Fitchburg division of the Boston & Maine, at Boston, Mass., has been appointed general superintendent, with office at Boston, succeeding W. F. Ray, deceased. Frank H. Flynn, trainmaster of the Southern division at Boston, succeeds Mr. Tyter. G. H. Folger, heretofore as-

sistant general superintendent at Boston, is now superintendent of the Terminal division, with headquarters at Boston, and his former position has been abolished.

General Manager Loree, of the Baltimore & Ohio Southwestern and Cincinnati, Hamilton & Dayton, announces that effective October 1, the jurisdiction of R. N. Begien, general superintendent of the Baltimore & Ohio Southwestern, is extended over that portion of the Cincinnati Terminal division comprising the Baltimore & Ohio Southwestern terminals, and the jurisdiction of H. B. Voorhees, general superintendent of the Cincinnati, Hamilton & Dayton, will extend over that portion of the Cincinnati Terminal division comprising the Cincinnati, Hamilton & Dayton terminals. Headquarters, Cincinnati, Ohio.

Fred. Smith Risley, whose appointment as assistant superintendent of the Mohawk division of the New York Central & Hudson River, with headquarters at Albany, N. Y., has been announced in these columns, was born on September 6, 1879, at Kingston, N. Y., and was educated in the schools of his native town. He began railway work in 1898, with the West Shore, a subsidiary of the New York Central & Hudson River, as an operator, remaining in that position until 1903, when he was appointed wire chief and later was made despatcher at Weehawken, N. J. In December, 1906, he was promoted to assistant trainmaster at Weehawken, and in September, 1908, became trainmaster on the N. Y. C. & H. R., at Richland, N. Y. He was transferred as trainmaster in January, 1910, to Albany, which position he held at the time of his recent appointment as assistant superintendent of the same road, as above noted.

David B. Fleming, whose appointment as superintendent of the Buffalo division of the New York Central & Hudson River, with headquarters at Buffalo, N. Y., has been announced in these

columns, was born on February 12, 1877, at Snowshoe, Pa. He began railway work in 1893, as a telegraph operator on the Beech Creek, now a part of the New York Central & Hudson River. In 1899 he was promoted to despatcher, becoming chief despatcher in 1902. He was appointed assistant trainmaster on the Pennsylvania division of the New York Central & Hudson River in 1904, and two years later was transferred in the same capacity to the Adirondack division at Utica, N. Y. In 1909, he went to the main line Mohawk division in charge of freight, and



D. B. Fleming.

the following year was appointed assistant superintendent of the Hudson division, with headquarters at New York. He was appointed assistant superintendent of the Mohawk division at Albany in 1911, which position he held at the time of his recent appointment as superintendent of the Buffalo division of the same road, as above noted.

E. J. Devans, superintendent of the Rochester and Buffalo divisions of the Buffalo, Rochester & Pittsburgh, at Rochester, N. Y., has been promoted to general superintendent in charge of transportation operations, with headquarters at Rochester. M. G. McInerney, assistant superintendent at Rochester, has been promoted to superintendent, Buffalo and Rochester divisions, with headquarters at Rochester. H. E. Patterson, trainmaster at East Salamanca, has been promoted to assistant superintendent, Buffalo and Rochester divisions, with headquarters at East Salamanca. T. C. McCarthy has been promoted to trainmaster, Buffalo and Rochester divisions, with headquarters at East Salamanca. G. W. Bennett, trainmaster at DuBois, Pa., has been promoted to assistant superintendent, Middle and Pittsburgh divisions, with headquarters at Indiana. R. F. Dawson has been promoted to assistant superintendent, Middle and Pitts-

burgh divisions, with headquarters at DuBois, and Jas. Spellen has been promoted to assistant superintendent, Middle and Pittsburgh divisions, with headquarters at Butler.

#### Traffic Officers.

E. W. Trott has been appointed traveling freight agent of the Missouri & North Arkansas, with headquarters at Joplin, Mo.

The headquarters of J. R. Veitch, assistant to the traffic manager of the Chicago, Milwaukee & St. Paul, have been moved from Chicago to Seattle, Wash.

R. F. Schneider, soliciting freight agent of the Missouri & North Arkansas at New Orleans, La., will also represent the Toledo, St. Louis & Western in a similar capacity.

George McDougall has been appointed dairy agent of the Cleveland, Cincinnati, Chicago & St. Louis and Lake Erie & Western at Indianapolis, Ind., succeeding J. E. Pierce, resigned.

E. A. Weiberg, city passenger agent of the Chicago & Alton at Springfield, Ill., has been appointed district passenger agent, with office at Peoria, Ill. M. W. Dancey succeeds Mr. Weiberg.

George W. Metzger, passenger agent of the Pennsylvania Lines at the Union station, Chicago, has been retired under the pension rules of the company. Mr. Metzger has been in the service of the Pennsylvania for 44 years.

J. I. Hazzard, formerly general agent of the Western Maryland at Chicago, has been appointed general agent of the Blue Ridge Despatch at that place, succeeding E. B. Webb, who succeeds Mr. Hazzard as general agent of the Western Maryland.

P. A. Sullivan has been appointed traveling freight agent of the Beaumont, Sour Lake & Western, New Orleans, Texas & Mexico, St. Louis, Brownsville & Mexico, Orange & North-western, St. Louis, San Francisco & Texas and Chicago & Eastern Illinois, with headquarters at San Antonio, Tex. Mr. Sullivan, who heretofore was soliciting freight agent at San Antonio, is succeeded by J. B. Burns. W. H. Pennick, traveling passenger agent at San Antonio, has been transferred to Houston, Tex., in a similar capacity. Elmer Mitchell, city passenger and ticket agent of the Frisco Lines at Fort Worth, Tex., has been appointed traveling passenger agent, retaining headquarters at Fort Worth.

#### Engineering and Rolling Stock Officers.

H. H. Parker, roundhouse foreman at the Portsmouth, Va., shops of the Seaboard Air Line, has been appointed general foreman of those shops.

C. A. McCarthy, master mechanic of the Chicago, Rock Island & Pacific at Shawnee, Okla., has resigned to become master mechanic of the Colorado Springs & Cripple Creek District Railway, with office at Colorado Springs, Colo.

The office of assistant superintendent of motive power of the Missouri, Kansas & Texas, at Denison, Tex., heretofore held by N. L. Smithan, has been abolished, and Mr. Smithan has been transferred to the mechanical department at Waco, Tex.

F. B. Walker has been appointed assistant engineer of the Chicago, Milwaukee & St. Paul, with office at Lewiston, Mont., succeeding F. J. Herlihy, resigned to accept a position with the Cook Construction Company of Montreal, Que. Mr. Walker will have charge of the bridge work between Great Falls and Lewiston.

J. B. Roach, master mechanic of the Chicago, Burlington & Quincy at Aurora, Ill., has been transferred to Beardstown, Ill., in a similar capacity, succeeding H. G. Castron, who goes to Brookfield, Mo., as master mechanic. H. S. Mored, master mechanic at Ottumwa, Iowa, succeeds Mr. Roach, and D. R. Sweney, road foreman of engines, takes the place of Mr. Mored.

W. U. Appleton, assistant to superintendent of motive power of the Intercolonial, at Moncton, N. B., has been appointed general master mechanic of the Intercolonial and the Prince Edward Island railways, in charge of all engine houses and shops (except Moncton shops), locomotives and machinery, and Jos. Graham, erecting house foreman at Moncton, has been appointed superintendent of the locomotive shops at Moncton, succeeding H. D. McKenzie, general locomotive foreman, transferred.

W. J. Frauendiener, who recently was appointed general in-

spector of the locomotive department of the Cleveland, Cincinnati, Chicago & St. Louis, at Indianapolis, Ind., has been appointed master mechanic of the Eastern division, with headquarters at Bellefontaine, Ohio, in place of J. T. Luscombe, resigned. K. Tate has been appointed assistant master mechanic at Bellefontaine.

H. W. Sharpe, acting master mechanic of the Intercolonial Railway at Riviere du Loup, Que., has been appointed district master mechanic, district No. 1, of the Intercolonial and the Prince Edward Island railways, with office at Riviere du Loup. T. W. Hennesey has been appointed district master mechanic, district No. 2, with office at Campbellton, N. B. W. E. Barnes has been appointed district master mechanic, district No. 3, with office at Moncton, and H. D. McKenzie, general locomotive foreman at Moncton, has been appointed district master mechanic, district No. 4, with office at Stellarton, N. S.

#### Purchasing Officers.

N. A. Waldron, formerly storekeeper of the St. Louis Southwestern, has been appointed general storekeeper of the Missouri, Kansas & Texas, with headquarters at Parsons, Kan., succeeding J. M. Gibbons, resigned.

#### OBITUARY.

H. W. Hartman, president of the Denver & South Platte, died at Denver, Colo., on September 29, aged 63 years.

George Andrews, general agent of the passenger department of the Pacific Coast Steamship Company at Seattle, Wash., died on September 25 at the age of 59 years.

S. M. Hudson, auditor of the Fort Worth & Denver City, with headquarters at Fort Worth, Tex., died September 30, at the Mayo sanitarium at Rochester, Minn., aged 64 years. Mr. Hudson began railway work in May, 1892. He was made auditor of the Fort Worth & Denver City in March, 1899, and had been consulting auditor also of the Wichita Valley since May, 1907.

E. T. White, district superintendent of motive power of the Baltimore & Ohio, at Baltimore, Md., died at his home in that city on September 26. He was born on October 16, 1858, at Fellowsville, Va., and began railway work in 1874, as a machinist apprentice on the Baltimore & Ohio, remaining in that position for four years. He was then, consecutively, gang foreman, roundhouse foreman, and general foreman of locomotive repairs on the same road, and from June, 1889, to February, 1895, was master mechanic on the Baltimore division. He was then transferred as master mechanic to the Philadelphia division, and from March, 1899, to May, 1905, was superintendent of motive power for the lines east of the Ohio river, and since that time has been successively superintendent of motive power on lines east of the Ohio river and lines in Pittsburgh territory, and superintendent of motive power of the main line. His entire service has been with the Baltimore & Ohio.

Maxwell Evarts, general counsel of the Southern Pacific with headquarters at New York, died on October 7, at his summer home at Windsor, Vt. He was born on November 15, 1862, in New York City, and graduated from Yale University in 1884 and went to the Harvard Law School. For a time he was engaged in law work in the office of W. D. Guthrie and was for a time assistant United States district attorney. He spent some time in the West on a ranch, and his first railway work was as an attorney for the Southern Pacific in 1893. Shortly after this he gave up private practice almost entirely and had been engaged in law work for the Southern Pacific ever since. His most important work for the Southern Pacific had been in connection with appeals to the United States Supreme Court. He argued nearly all of the cases that were carried to the Supreme Court, either jointly with the counsel that tried the cases in the lower courts or alone. He took Judge Lovett's place as general counsel of the Harriman Lines in October, 1910, and early in 1913, when the Southern Pacific was separated from the Union Pacific he resigned as general counsel of the Union Pacific, remaining with the Southern Pacific as general counsel. He was also a director of the Southern Pacific. Mr. Evarts was a man who took life smilingly and who took a keen interest in his country place in Vermont. A few years ago he served two terms in the Vermont legislature. Mr. Evarts was the son of the late Secretary of State William Maxwell Evarts.



## Equipment and Supplies.

### LOCOMOTIVE BUILDING.

THE DELAWARE & HUDSON is considering the purchase of 10 locomotives.

THE CAMBRIA & INDIANA has ordered 1 mikado locomotive from the Baldwin Locomotive Works.

THE ATLANTIC NORTHERN & SOUTHERN has ordered 1 mogul locomotive from the Baldwin Locomotive Works.

THE SAN PEDRO, LOS ANGELES & SALT LAKE has ordered 3 six-wheel switching locomotives from the Baldwin Locomotive Works.

THE DOMINION COAL COMPANY, LTD., has ordered 1 consolidation locomotive from the Montreal Locomotive Works. The dimensions of the cylinders will be 21 x 26 in.; the diameter of the driving wheels will be 50 in., the total weight in working order will be 179,000 lbs., and the steam pressure will be 200 lbs.

THE PEKING-KALGAN RAILWAY, CHINA, has ordered 5 Pacific type locomotives and 4 mikado locomotives from the American Locomotive Company. The Pacific type locomotives will have superheaters, 20 in. x 26 in. cylinders, 62 in driving wheels, a steam pressure of 180 lbs., and in working order will weigh 180,000 lbs. The mikado locomotives will be equipped with superheaters; will have 20 in. x 28 in. cylinders, 50 in. driving wheels, a steam pressure of 180 lbs., and in working order will weigh 185,000 lbs.

### CAR BUILDING.

THE NEW YORK CENTRAL LINES announce that they have not ordered 2,000 refrigerator cars from the Merchants Despatch Transportation Company, as has been rumored.

THE GREAT NORTHERN, mentioned in last week's issue as being in the market for passenger cars, has ordered ten 60-ft. steel mail cars from the Barney & Smith Car Company, and contemplates purchasing 50 first class coaches, 20 baggage cars, 25 sleeping cars and 10 cafe-parlor cars. All of these cars will have steel underframes.

### IRON AND STEEL.

THE CHICAGO & ALTON has ordered 5,000 tons of Titanium open hearth rails.

THE MISSOURI PACIFIC has ordered 10,000 tons of rails from the Pennsylvania Steel Company.

GENERAL CONDITIONS IN STEEL.—The principal interest in the steel industry is now centered in the probable effect of the new tariff schedule. The full effect of this schedule cannot be expected inside of three months. Thus far no important importations have occurred. It is believed that the effect will be felt on the Pacific coast at an earlier date than in the interior or on the Atlantic coast. This is due largely to the fact that the freight rate from Antwerp to San Francisco is only \$6 per ton, while from domestic mills to the Pacific coast the rate is \$15 to \$16 per ton.

### SIGNALING.

The Southern Railway is installing automatic block signals on its line from Seminary, Va., to Orange, Va., 80 miles, double track. When this installation is finished trains will be run under automatic signals from Washington to Orange, 86 miles.

FOURTEEN PASSENGERS KILLED IN RUSSIA.—A press despatch from Dvinsk, Russia, October 6, says that in a collision at the station in that city, 14 passengers were killed and 28 injured. An express train bound from Kieff to St. Petersburg ran into an engine standing on the main track near the station.

## Supply Trade News.

The American Steel Foundries, Chicago, has moved its general offices from the National Bank building to the eleventh and twelfth floors of the McCormick building, Chicago.

George Horton, of the Chicago Bridge & Iron Works, has been made a vice-president of the T. W. Snow Construction Company, Chicago, succeeding R. E. Gurley, resigned to become a director.

J. B. Kilpatrick, formerly mechanical superintendent for the First district of the Rock Island Lines, with office at Des Moines, Iowa, has been made a vice-president of the Chicago Air Brake Company, with office in Chicago.

The Roberts & Schaefer Company, Chicago, has received a contract from the Illinois Central for the construction of a 500-ton, counterbalanced bucket type, Holmen, locomotive coal-ling station at the new terminal which the company is building at the Nonconah yards, Memphis, Tenn. The contract price will be approximately \$14,000.

The Watson-Stillman Company, New York, has received orders for the dome connection style Chambers throttle valve for the following locomotives: 110 mikado locomotives ordered from the Baldwin Locomotive Works by the Baltimore & Ohio, 34 locomotives ordered by the Southern Railway from the Baldwin Locomotive Works, 12 locomotives ordered by the Bessemer & Lake Erie from the American Locomotive Company, and 57 locomotives ordered by the Chicago, Rock Island & Pacific from the American Locomotive Company.

Alexander Koch, president of Alexander Koch, Ltd., of Vienna, Austria (Nibelungengasse, 1 u. 3), contractor in Vienna for J. & P. Hill, Ltd., and foreign agent for various American companies, including the Locomotive Superheater Company, New York, who represented the Austrian government at the International Congress of Refrigeration in Chicago, is desirous of meeting American manufacturers of railway supplies and equipment who have representatives in Europe or England, or who are considering establishing European or English agencies. Mr. Koch is stopping at the Hotel Vanderbilt, New York.

### TRADE PUBLICATIONS.

SAND BLASTS.—J. M. Betton, 26 Park place, New York, has published a pamphlet in Spanish, describing the Drucklieb sand blast and furnishing information on the use and care of these devices.

STEEL SASH.—The Trussed Concrete Steel Company, of Detroit, Mich., has issued an illustrated booklet of 112 pages, devoted to united steel sash, including side wall sash with pivoted or sliding ventilators, continuous sash center pivoted or top hung for monitor and sawtooth roof construction, hinged and sliding doors, metal and glass partitions, casement sash and special sash for various requirements. Complete details and specifications are given for the various types, together with a large amount of interesting information in connection with roof and window construction, and illustrations of a large number of buildings in which this company's sash has been installed.

TITANIUM ALLOY IN OPEN HEARTH RAILS.—The Titanium Manufacturing Company, Niagara Falls, N. Y., has issued bulletin No. 2 of its series of rail reports which were reviewed in the *Railway Age Gazette* of August 1, page 210. The second bulletin confirms the opinion expressed in the former review, that the method of presenting the data is excellent. The preface to the present bulletin states that the principal objection expressed to the data printed in bulletin No. 1 has reference to the accuracy of sulphur prints which form a part of comparative data shown. To answer any question as to the accuracy of such comparisons the present bulletin includes the instructions under which such sulphur prints are made, showing a degree of care that insures fair comparisons. The second bulletin covers complete tests, chemical, physical and microscopic on three of the four sets of open hearth and Titanium treated rails of which sulphur prints were shown in bulletin No. 1. The conclusions drawn from the comparisons are essentially the same as those in the first bulletin.

## Railway Construction.

**CHESAPEAKE & OHIO.**—The report of this company for the year ended June 30, 1913, shows that extensions of the Cabin Creek, the Coal River and the Guyandot Valley (Rum Creek branch), aggregating 18.5 miles, were completed.

**CHICAGO & ALTON.**—An officer writes that the company will lay a temporary second main track between Atlanta, Ill., and Lawndale. This track will be used until the company is able to complete the grade revision work which it contemplates carrying out between those two places.

**CHICAGO, MILWAUKEE & ST. PAUL.**—According to press reports bids were recently asked for building a 41-mile section of the Puget Sound & Willapa Harbor from Maytown, Wash., through Centralia to Chehalis, thence along the Chehalis river to Doty. This company was organized to build from Raymond, Wash., on Willapa harbor, east to Chehalis, thence north via Centralia to Maytown, 65 miles. A contract was recently let to the Keasel Construction Company, Tacoma, Wash., to build the first section and this work is now under way. (September 5, p. 436.)

The Chicago, Milwaukee & St. Paul, it is said, recently opened for operation the line between Plummer, Idaho, and Spokane, Wash. (April 18, p. 925.)

**CUMBERLAND VALLEY ELECTRIC.**—Surveys are being made it is said, from Nashville, Tenn., southeast, via Donelson, Gladeville, Henderson's Cross Roads and Statesville. The line is projected southeast, via DeKalb county to Sparta, about 80 miles from Nashville. See Cumberland Valley Interurban. (July 25, p. 169.)

**GULF, FLORIDA & ALABAMA.**—We are told that a contract has been given to J. P. McCarthy, Gainesville, Ga., to grade 50 miles from the present northern terminus at Broughton station, Ala., to Pine Hill, where a connection is to be made with the Southern Railway. Bids were recently asked for the masonry and steel work on a steel drawbridge, about 2,000 ft. long, including approaches, to be built over the Alabama river at Yellow Bluff. (April 18, p. 925.)

**NEW YORK SUBWAYS.**—The New York Public Service Commission, First district, has authorized the New York Municipal Railway Corporation (Brooklyn Rapid Transit) to make a contract with George W. McNulty for the immediate reconstruction of the Sea Beach Railroad from its connection with the Fourth avenue subway, at about Sixty-fifth street, Brooklyn, to a point immediately south of Eighty-sixth street, near Coney Island. This line will be one of the Coney Island connections with the new Fourth avenue subway, and it will be a four track line, built in a cut for the greater part of the distance. The reconstruction work is to cost about \$1,877,525.

Bids for the construction of a section of the proposed Seventh avenue subway in the borough of Manhattan were opened by the New York Public Service Commission, First district, on October 1. The section is known as section No. 2, of routes Nos. 4 and 38, a part of the new system which will be operated by the Interborough Rapid Transit Company in connection with the existing subway. It will be a four track underground railroad from Times square, borough of Manhattan, to Park place, where two of the tracks will continue to the Battery and two diverge to Brooklyn. Section No. 2 covers a part of the line under Greenwich street, West Broadway and Varick street between Vesey street and Beach street. According to unofficial figures furnished by the contractors, the lowest bidder was the Thomas J. Buckley Engineering Company, New York City, at \$3,036,000, and the next lowest bidder the O'Rourke Engineering Construction Company, New York City, at \$3,138,000. As soon as the engineers' report is received, the commission will award the contract. (September 26, p. 586.)

**PUGET SOUND & WILLAPA HARBOR.**—See Chicago, Milwaukee & St. Paul.

**ST. LOUIS SOUTHWESTERN.**—The report of this company for the year ended June 30, 1913, shows that the work of constructing second main track between certain points and extending passing tracks, which extensions will, in future, be available for use as a part of second main track, between Illmo, Mo., and Paragould, Ark., a distance of 110.4 miles, was commenced

during the year. The second main track from Ancell, Mo., to Rockview, 5.33 miles, was completed and placed in service in June, 1913, and second main track from Idalia, Mo., to Dexter Junction 6.26 miles, was also completed at the close of the fiscal year, with the exception of about four miles to be ballasted. About 75 per cent. of the grading of second main track between Idalia and Avert, 6.2 miles, has been completed. Also some grading at various points between Avert and Randles, 17.1 miles. The passing tracks at Ardeola, Dexter Junction and Malden, Mo., were extended to a total of 7,000 ft., and placed in service. Similar extensions are in progress at Randles, at Paradise, at Idalia, Mo., at Greenway, at Rector, at Marmaduke and at Paragould, Ark. The extensive terminal yard at Main and Florida streets, St. Louis, Mo., was completed and placed in operation January 1, 1913, and work was commenced during the year on the new freight terminals at Fort Worth, Tex. Additional ground has been bought and right of way secured for a line to extend from the existing line at North Fort Worth to the new terminal.

**SEABOARD AIR LINE.**—An officer writes that a contract has been given to E. Chapman, Plant City, Fla., to build about 4.9 miles, from Morriston, Fla., to the Acme Phosphate Company's plant.

### RAILWAY STRUCTURES.

**BALTIMORE, MD.**—The Baltimore & Ohio has given a contract for paving, concreting and waterproofing the Lee street bridge, in South Baltimore, this being part of the program of grade crossing elimination which the company has under way there. The railroad has entered into an arrangement with the city which involves the carrying of four streets over the railroad tracks and removing the thoroughfares from a busy section of the Camden terminals. A city ordinance calls for the completion of one bridge each year.

**BROOKLYN, N. Y.**—The Long Island Railroad has been directed by the New York Public Service Commission, First district, to begin work at once on a foot passageway to be constructed underneath the tracks in Atlantic avenue at the Railroad avenue crossing.

**MERRITTON, ONT.**—A contract has been given by the Department of Railways and Canals of the Dominion of Canada, to the Hamilton Bridge Works Company, Ltd., Hamilton, Ont., for fabricating the material and the erection of a one span steel railway swing bridge, to carry two tracks over the new Welland canal at Merritton. The new structure will require 500 tons of steel and the cost of the improvement will be about \$65,000.

**MONTREAL, QUE.**—The Canadian Pacific has given a contract to John S. Metcalf Co., Limited, Montreal, for building an extension of the Glen arch at Westmount, Montreal. The improvement is to be made to provide a roadway for four tracks over the structure. The estimated cost of the work is \$50,000.

**NORTHPORT, N. Y.**—Plans are being made for putting up a new passenger station on the Long Island Railroad at Northport, to cost about \$20,000. The construction work will probably be carried out by the company's forces.

**TEXARKANA, TEXAS.**—The report of the St. Louis Southwestern for the year ended June 30, 1913, shows that the steel viaduct at Texarkana, Tex., constructed jointly by the St. Louis Southwestern, the Kansas City Southern and the Texas & Pacific, was completed and placed in operation. The work of replacing the draw span over White river at Clarendon, Ark., is nearing completion, and the work of replacing metal bridges over South Bosque river, Harris creek and first and second crossings of Leon river with heavier spans was completed. A reinforced concrete fireproof freight house at Main and Florida streets, St. Louis, 30 ft. wide x 750 ft. long and five stories high, was completed and placed in service January 1, 1913; and a brick passenger station was built at Brinkley, Ark., and is owned jointly with the Chicago, Rock Island & Pacific. A brick division office building was put up at Mt. Pleasant, Tex., and a combined brick freight and passenger station at Gatesville, were also completed during the year.

**YELLOW BLUFF, ALA.**—See Gulf, Florida & Alabama, under Railway Construction.

## Railway Financial News.

**ATLANTIC COAST LINE.**—The railroad commission of Florida has approved of the purchase by the Atlantic Coast Line of the property and franchises of the Sanford & Everglades. This line runs from Sanford southeast through the celery growing district of Seminole county, 9½ miles.

**BALTIMORE & OHIO CHICAGO TERMINAL.**—Negotiations are being carried on between this company and the Chicago, Terre Haute & Southeastern for the joint use of the tracks from Chicago Heights to Harvey Junction.

**DENVER & SALT LAKE.**—The agreement by which the city of Denver is to aid in building the tunnel through the continental divide, which will permit of the extension of the Denver & Salt Lake to Salt Lake City, has been signed by the members of the tunnel commission of Denver, and when signed by Newman Erb will provide for a tunnel to cost about \$4,500,000, of which the city will furnish about \$3,000,000. It will be necessary to hold a special election to get the approval of the city for the issue of its bonds to cover this amount of money.

**FITCHBURG RAILROAD.**—Stockholders have authorized the issue of \$2,100,000 bonds, of the proceeds from the sale of which \$500,000 will be used for refunding a like amount of bonds due May 1, 1914.

**NATIONAL RAILWAYS OF MEXICO.**—D. P. Bennett, vice-president; Henry W. Taft and Ricardo Huerta have been elected members of the New York board of directors of the National Railways of Mexico, succeeding Henry Clay Pierce, E. Martinez Sobral, former consul general of Mexico at New York, and James N. Wallace, whose resignation has previously been announced.

Guillermo Brockmann, Isaac Bustamente, Adolfo Christlieb, Eduardo Lobaton, Antonio Perez, Emilio Rabast and José Simon have been elected members of the Mexican board of directors. The directors have been authorized to arrange for the issue of additional preferred stock or general mortgage bonds in such amounts as may be necessary to cover the losses resulting from the revolution, and the Mexican government has accepted the responsibility for such losses as damage to military trains, to roads by government troops, and to lines temporarily confiscated by military authorities. The agreement which has been reached by which President Brown will remain with the company is noted in the elections and appointments column.

**NEW YORK, NEW HAVEN & HARTFORD.**—The directors in answer to the criticisms made by the Interstate Commerce Commission's report announce the appointment of the following committee, to report not later than December 1:

A committee to investigate the Connecticut trolley situation, to consist of Samuel Rea, John L. Billard, Charles F. Brooker, James S. Hemingway, William Rockefeller, A. T. Hadley and Howard Elliott. This committee is to confer with and get the views of the Public Utilities Commission of Connecticut, and with George M. Woodruff, of Connecticut, of the Committee on Trolley Affairs of the New England Railroad Conference created by the governors of the New England states.

A committee to investigate on the Rhode Island trolley situation consisting of D. Newton Barney, Robert W. Taft, Edward Milligan, Edwin Milner, T. DeWitt Cuyler, Howard Elliott and Vice-President Buckland.

A committee to investigate the steamship situation to consist of A. Heaton Robertson, Henry K. McHarg, J. T. Pratt, George F. Baker, Francis T. Maxwell, Howard Elliott and J. Howland Gardner, vice-president of the New England Steamship Company. This committee is instructed to confer with Franklin W. Cram, of Maine, on the Committee on Steamship Affairs of the New England Railroad Conference.

A committee to investigate the relations of the company with the Boston & Albany, to consist of W. Murray Crane, Theodore N. Vail, Alexander Cochrane, William Skinner, James S. Elton and J. H. Hustis. This committee is instructed to confer with the Public Service Commission of Massachusetts and with some member of the New England railroad conference to be named by that body.

A committee to investigate the Western Massachusetts trolley situation, to consist of C. F. Brooker, W. Murray Crane, Lawrence Minot, Frederick F. Brewster, J. H. Hustis. This committee is instructed to confer with the Public Service Commission of Massachusetts and with George M. Woodruff.

A committee to investigate the relations of the New York, New Haven & Hartford and Boston & Maine roads, to consist of C. F. Brooker, William Skinner, T. N. Vail, Alexander Cochrane, Arthur T. Hadley and Howard Elliott. The directors of the Boston & Maine are asked to appoint a committee from among their number, and these two committees are to confer with one another and with F. T. Bowles, of the committee on Boston & Maine of the New England Conference.

All of these committees shall select their own chairman and are given full power to call upon officers and employees for any and all information which will be promptly furnished, and shall have power to incur reasonable expenses.

**PARAGOULD SOUTHEASTERN.**—See St. Louis Southwestern.

**ST. LOUIS SOUTHWESTERN.**—Stockholders have authorized the directors to issue \$5,000,000 bonds. It is understood that not more than \$500,000 of these bonds will be issued in the near future, which amount will be used to reimburse the company for additions and betterments made to the Paragould Southeastern. The stockholders also ratified the lease of the Paragould Southeastern for 30 years.

**SANFORD & EVERGLADES.**—See Atlantic Coast Line.

**TRANS-MISSISSIPPI TERMINAL COMPANY.**—See Texas & Pacific.

**TEXAS & PACIFIC.**—*The Commercial & Financial Chronicle* prints the following as authoritative:

"With respect to the report from New Orleans that the Terminal Company which was organized to construct a terminal there for the Texas & Pacific has sold \$8,000,000 bonds, which have been taken by the Gould family, it was learned that the following are the facts: A mortgage for \$10,000,000, covering a similar amount of bonds, has been drawn up and filed by the Terminal Company. In the near future about \$4,000,000 of this issue will be put out and the proceeds, if the bonds are sold, will be turned over to the Gould estate to reimburse it for moneys advanced to the Terminal Company. If the bonds are not sold, it is understood that the estate will take them. The balance of the total authorized issue will be held in the company's treasury and will be issued from time to time to pay for further developments of the property.

"The bonds are to be guaranteed both as to principal and interest by the Texas & Pacific, which owns all the stock of the Terminal Company. The first cost of the latter property will be between \$4,000,000 and \$5,000,000. It is understood that in return for the money advanced by the Gould estate, it received originally only the purchase-money notes of the Terminal Company."

**24 O'CLOCK IN SWITZERLAND.**—The numbering of the hours from 1 to 24 instead of going round the clock twice in a day is found in Italy, France, Belgium, Spain and Portugal. In Switzerland the older method still prevails, as in England, and as in Germany and Austria. Some trouble is constantly being experienced on the Simplon route in this matter, as the two ends—Italy and France—have the 24-hour timing, while Switzerland retains the 1 to 12. An agitation for a change having been aroused, the Federal Council made inquiries and found that the post and telegraph department was willing to make any change, if agreed to, and the customs had no objection. The Swiss Union of Trade and Industry took counsel of its sections and found 38 of them in favor of the reform and only seven against it. Seventeen of the leading Cantons also approved, but eight were against a change. The latter are the Cantons nearest Germany and Austria, which preferred the present reckoning so long as it was retained in Germany and Austria. The Federal Council, therefore, decided to do nothing for the present, as any change would simply be transferring to the northern and eastern frontiers the difficulties now experienced on the southern and western.

# ANNUAL REPORTS.

## THE CHESAPEAKE AND OHIO RAILWAY COMPANY—THIRTY-FIFTH ANNUAL REPORT.

RICHMOND, Va., September 17, 1913.

**TO THE STOCKHOLDERS:**

The Thirty-fifth Annual Report of the Board of Directors, for the fiscal year ended June 30, 1913, is herewith submitted.

The average mileage operated during the year by The Chesapeake and Ohio Lines was 2,319 miles, an increase over the previous year of 55.9 miles. The mileage at the end of the year was 2,337.7 miles, an increase of 32.2 miles over mileage on June 30, 1912. See schedule on page 12.

The operations of the Chicago Line (The Chesapeake and Ohio Railway Company of Indiana) are included in this report. Its operating revenues increased 27% over last year, and, in spite of the extraordinary expenditures made necessary by the floods of the Miami and Wabash Rivers, its expenses decreased 8%, and \$118,664.27 was earned towards interest charges on its bonded debt, all of which is held by your Company.

**RESULTS FOR THE YEAR.**

Operating Revenues were.....	\$35,085,278.32
(Increase \$795,408.55, or 2.32%.)	
Operating Expenses were.....	24,451,560.31
(Increase \$1,815,879.27, or 8.02%.)	
Net Operating Revenue was.....	\$10,633,718.01
(Decrease \$1,020,470.72, or 8.76%.)	
Taxes were.....	1,375,862.89
(Increase \$361,642.95, or 35.66%.)	
Operating Income, Taxes deducted, was.....	\$ 9,257,855.12
(Decrease \$1,382,113.67, or 12.99%.)	
Miscellaneous Income was.....	2,225,536.80
(Increase \$416,973.90, or 23.06%.)	
	\$11,483,391.92
Rentals and Other Payments were.....	865,730.10
(Increase \$33,710.93, or 4.05%.)	
Income for the year available for interest was.....	\$10,617,661.82
(Decrease \$998,850.70, or 8.60%.)	
Interest (68.93% of amount available) amounted to.....	7,319,158.44
(Decrease \$23,148.05, or 0.32%.)	
Net Income for the year, equivalent to 5.25% on capital stock outstanding, amounted to.....	\$ 3,298,503.38
(Decrease \$975,702.65, or 22.83%.)	
Dividends paid during the year: Four dividends of 1/4% each, aggregating.....	3,139,080.00
Remainder.....	\$ 159,423.38

**FINANCIAL.**

The changes in funded debt in the hands of the public during the year were as follows:

	Sold	Retired
4 1/2 per cent. Secured Gold Notes.....	\$5,500,000.00	
5 per cent. Secured Gold Notes.....	3,500,000.00	
4 per cent. Big Sandy Ry. First Mortgage Bonds.....	229,000.00	\$ 55,000.00
4 per cent. Coal River Ry. First Mortgage Bonds.....	41,000.00	29,000.00
4 per cent. Greenbrier Ry. First Mortgage Bonds.....		18,000.00
4 per cent. Raleigh & Southwestern Ry. First Mortgage Bonds.....		8,000.00
5 per cent. General Funding and Improvement Mortgage Bonds.....		515,000.00
Equipment Trust Obligations.....		1,939,523.25
	\$9,270,000.00	\$2,564,523.25
Net increase.....	6,705,476.75	

Other changes in funded debt shown on balance sheet of June 30, 1913, were:

	Increase
5 per cent. First Lien and Improvement Mortgage Bonds.....	\$10,362,000.00
4 per cent. Coal River Ry. First Mortgage Bonds.....	445,000.00
5 per cent. Va. Air Line Ry. First Mortgage Bonds (assumed).....	900,000.00

No First Lien and Improvement Mortgage Bonds have yet been sold, \$32,586,000.00 face amount being pledged as collateral for your Company's Secured Gold Notes. Those issued during the year were on account of the acquisition of certain stocks and bonds, for additions and betterments and other capital purposes. Secured Gold Notes issued during the year were sold to provide funds for new equipment, improvements and other acquisitions. Big Sandy Railway Company First Mortgage Bonds and Coal River Railway Company First Mortgage Bonds were issued during the year for capital expenditures on those branch lines. Virginia Air Line Railway Company's First Mortgage Bonds were assumed upon the acquisition by your Company during the year of that Company's property comprising 29.8 miles of line, such acquisition having been authorized by the stockholders at the annual meeting in October, 1909.

Your Company acquired during the year additional shares of stock of White Sulphur Springs, Inc., Logan and Southern Railway Company, and Silver Grove Land and Building Company; and acquired all of the capital stock of Elkhorn and Beaver Valley Railway Company and Gauley and Meadow River Railroad Company. The Chesapeake and Ohio Railway Company of Indiana acquired 2,400 shares of capital stock of The Belt Railway Company of Chicago. Further shares of stock and First Mortgage Bonds of The Chesapeake and Ohio Railway Company of Indiana were issued in respect of the cost of certain additions and betterments made to that line and were pledged under your Company's First Lien and Improvement Mortgage.

A statement of charges to property accounts will be found on page 16, showing a net addition of \$3,410,102.91; that is, \$3,905,679.94 was added to cost of road, which includes \$2,819,962.82 for additions and betterments and \$1,085,711.12 for the Virginia Air Line—heretofore operated by your Company but now merged by deed—and for certain other items, less \$495,577.03 deducted from cost of equipment owing to the fact that equipment retirements for the year were in excess of the cost of equipment purchased directly by your Company, equipment under contract not having been received until after the close of the fiscal year. The Chesapeake and Ohio Equipment Corporation issued \$18,500 par amount of stock and \$2,122,000 face amount of notes for purchase of new equipment, all of which were acquired by your Company at a cost of \$2,136,743.30. The total property investment pertaining to the fiscal year was therefore \$5,546,846.21, of which \$4,956,706.12 represents equipment and other additions and betterments.

A schedule of securities owned June 30, 1913, will be found on page 17. During the past four years your Company's increase in capital liabilities in hands of the public, its principal acquisition of stocks and bonds of other companies, and its expenditures for equipment, branch line construction, second track, and other additions and betterments have been as follows:

CAPITAL OBLIGATIONS ISSUED OR ASSUMED:	PAR VALUE.
General Mortgage 4 1/2% Bonds.....	\$ 3,716,000.00
First Consolidated Mortgage 5% Bonds.....	2,000,000.00
Convertible 4 1/2% Debentures.....	31,390,000.00
Three Year 4 1/2% Collateral Trust Notes.....	25,000,000.00
One Year 5% Collateral Trust Notes.....	3,500,000.00
Coal River Railway Co. First Mortgage 4% Bonds.....	2,351,000.00
Raleigh and Southwestern Railway Co. First Mortgage 4% Bonds.....	350,000.00
Big Sandy Railway Co. First Mortgage 4% Bonds.....	229,000.00
Virginia Air Line Railway Co. First Mortgage 5% Bonds.....	900,000.00
	\$69,436,000.00

Realizing..... \$65,761,475.00

CAPITAL OBLIGATIONS PAID OR PURCHASED:	
Peninsula Division First Mortgage 6% Bonds maturing January 1, 1911.....	\$ 2,000,000.00
Greenbrier and New River Railroad Co. First Mortgage 5% Bonds redeemed February 1, 1911.....	339,000.00
General Funding and Improvement Mortgage 5% Bonds.....	7,302,000.00
Greenbrier Railway Co. First Mortgage 4% Bonds retired November 1, 1911.....	2,000.00
Equipment Trust Payments.....	8,044,000.00
Through Sinking Funds:	
Big Sandy Railway Co. First Mortgage 4% Bonds.....	212,000.00
Coal River Railway Co. First Mortgage 4% Bonds.....	85,000.00
Greenbrier Railway Co. First Mortgage 4% Bonds.....	78,000.00
Raleigh and Southwestern Railway Co. First Mortgage 4% Bonds.....	14,000.00
	\$18,076,000.00

Costing..... 18,399,696.25  
**\$47,361,778.75**

**ACQUISITIONS:**

Stocks of:	
The C. & O. Railway Co. of Indiana.....	\$ 5,748,800.00
Elkhorn and Beaver Valley Railway Co.....	308,000.00
Gauley and Meadow River Railroad Co.....	106,200.00
The Hocking Valley Railway Co.....	7,671,800.00
The Kanawha and Michigan Railway Co.....	4,029,200.00
Logan and Southern Railway Co.....	166,700.00
Levisa River Railroad Co. (of Ky.).....	50,000.00
The Levisa River Railroad Co. (of Va.).....	50,000.00
Kanawha Bridge and Terminal Co.....	400,000.00
Silver Grove Land and Building Co.....	200,000.00
White Sulphur Springs, Incorporated.....	1,498,200.00
First National Bank Building Corporation.....	180,000.00
Miscellaneous.....	6,000.00
	\$20,414,900.00

Costing..... \$20,645,046.39

Bonds of:	
The C. & O. Railway Co. of Indiana First Mortgage 5%.....	\$ 6,589,000.00

Costing..... 5,311,700.00

Properties of:	
Coal River Railway Co.....	\$ 2,304,359.88
Raleigh and Southwestern Railway Co.....	816,562.42
Virginia Air Line Railway Co.....	1,071,947.12

Costing..... 4,192,869.42

Construction of:	
Extensions of Branch Lines, costing.....	\$ 1,537,041.56
Second Track, (173.1 miles) and Additions and Betterments, costing.....	12,543,010.34
(Excluding \$1,896,363.48 expended on Chicago Line to April 30, 1913, for which securities have been acquired.)	
	14,080,051.90

Equipment: Additional equipment acquired (less retirements)... 1,637,883.36

(Excluding \$57,747.76 expended on Chicago Line to April 30, 1913, for which securities have been acquired.)	
Securities of The Chesapeake and Ohio Equipment Corporation acquired:	
Stock.....	\$1,388,500.00
Notes.....	9,782,000.00
	\$11,170,500.00

Costing..... \$11,166,743.30

\$57,034,294.37

**GENERAL REMARKS.**

The equipment inventory as of June 30, 1913, was as follows:			
Locomotives owned.....	536	Dec.	2
Locomotives leased.....	275	Inc.	20
Total.....	811	Inc.	18
Passenger train cars owned.....	348	Inc.	4
Passenger train cars leased.....	29	.....	.....
Total.....	377	Inc.	4
Freight train and miscellaneous cars owned.....	21,656	Inc.	2,116
Freight train cars leased.....	22,055	Dec.	3,210
Total.....	43,711	Dec.	1,094

The decrease in equipment is due principally to the retiral of light

capacity wooden equipment in place of which your Company has contracted for seventy ton steel cars.

The changes during the year in the reserve for accrued depreciation of equipment are as follows:

Balance to credit of account June 30, 1912.....	\$2,790,280.31
Amount credited during year ended June 30, 1913, by charges to:	
Operating expenses.....	\$773,327.05
Outside operations expenses.....	17,669.28
	<u>\$790,996.33</u>
Charges to account for:	
Accrued depreciation on equipment retired during year—	
36 locomotives, 1 passenger and 1,113 freight and work cars.....	\$ 76,561.87
Accrued depreciation on cars changed in class during year.....	1,365.87
	<u>77,927.74</u>
	<u>713,068.59</u>
Balance to credit of account June 30, 1913.....	\$3,503,348.90

Increased wages affecting all branches of the service were effective during the entire fiscal year, with the exception of conductors and trainmen who were advanced September 1, 1912, and the clerical forces who were advanced February 1, 1913. The cost of all such increases for the period was approximately \$825,000.

The taxes imposed, particularly in Kentucky, upon the lines of your Company have been very considerably increased, necessitating an accrual of \$361,642.95 more than in the previous fiscal year.

Unprecedented floods in the James River and Ohio valleys during the last week in March seriously affected the gross and net earnings, and while your lines were open for full operation within ten days your principal connections were unable to interchange traffic in any considerable volume during the entire month of April and are still restricted in their operations.

The amounts charged to operating expenses on account of flood damages aggregate, to June 30th, \$325,273.20.

There were severe and prolonged strikes by the coal miners in certain sections of West Virginia adjoining the lines of your Company, materially reducing the output of the mines affected.

GENERAL BALANCE SHEET, JUNE 30, 1913.

ASSETS.	LIABILITIES.
(Excluding Stocks and Bonds owned of The C. & O. Ry. Co. of Indiana.)	(Excluding Stocks and Bonds owned of The C. & O. Ry. Co. of Indiana.)
<b>TABLE 3.</b>	<b>Capital Stock.</b>
<i>Property Investment.</i>	Common .....
Cost of Road.....	First Preferred .....
Cost of Equipment.....	Second Preferred .....
Reserved for Accrued Depreciation of Equipment—Cr..	Common—The Chesapeake and Ohio Railway Co. of Indiana
<i>Securities of Proprietary, Affiliated and Controlled Companies—Pledged.</i>	<b>Funded Debt.</b>
Stocks—See Schedule, page 18	Secured Gold Notes, 5%, 1914
Bonds—See Schedule, page 18	Secured Gold Notes, 4½%, 1914
	First Mortgage, Kineon Coal Co., 5% Bonds.....1915
	First Mortgage Terminal, etc., 6% Bonds.....1922
<i>Securities—Issued or Assumed—Pledged.</i>	General Funding and Improvement, 5% Bonds.....1929
Bonds—See Schedule, page 18	Convertible 4½% Bonds, 1930
(Includes First Lien and Improvement Mortgage 5% Bonds \$32,586,000.00. See Contra.)	First Mortgage, R. & S. W. Railway, 4% Bonds...1936
	First Consolidated Mortgage, 5% Bonds.....1939
<i>Miscellaneous Investments.</i>	First Mortgage, Craig Valley Branch, 5% Bonds...1940
Physical Property .....	First Mortgage, Greenbrier Railway, 4% Bonds...1940
<i>Special Funds, and Funded Debt Issued and Reserved.</i>	First Mortgage, Warm Springs Branch, 5% Bonds...1941
Potts Creek Branch—Cash..	First Mortgage, Big Sandy Railway, 4% Bonds...1944
Raleigh and Southwestern Railway Bonds authenticated in advance of construction...	First Mortgage, Paint Creek Branch, 4% Bonds...1945
Special Deposits account of Construction .....	First Mortgage, Coal River Railway, 4% Bonds...1945
	First Mortgage, Potts Creek Branch, 4% Bonds...1946
	First Mortgage, Va. Air Line, 5% Bonds.....1952
<i>Working Assets.</i>	First Mortgage, R. & A. Division, 4% Bonds...1989
Cash in Treasury \$2,102,339.11	Second Mortgage, R. & A. Division, 4% Bonds...1989
Cash in Transit. 825,756.52	General Mortgage, 4½% Bonds.....1992
Cash deposits to pay Interest and Dividends .....	
Cash deposits to pay Equipment Trust Principal.....	Equipment Trust Obligations.
Cash deposits to pay Matured Bonds and Scrip....	First Lien and Improvement Mortgage, 5% Bonds (see Contra) .....
Loans and Bills Receivable..	
Traffic Balances .....	<i>Working Liabilities.</i>
Agents and Conductors.....	Loans and Bills Payable.....
Miscellaneous Accounts Receivable .....	Traffic Balances .....
Other Working Assets.....	Audited Vouchers and Pay Rolls .....
	Unpaid Wages .....
Materials and Supplies.....	Miscellaneous Accounts Payable .....
<i>Securities in Treasury—Unpledged.</i>	Interest and Dividends Unpaid
Stocks—See Schedule, page 17	Matured Mortgage and Secured Debt Unpaid.....
Bonds—See Schedule, page 17	Other Working Liabilities...
<i>Deferred Assets.</i>	<b>Deferred Liabilities.</b>
Unmatured Interest and Dividends .....	Unmatured Interest and Rents
Advances to Proprietary, Affiliated and Controlled Companies .....	Taxes Accrued .....
Advances, Working Funds (Fast Freight Lines, etc.)	Sundry Accounts .....
Special Deposits with Trustees, Various Mortgage Funds..	
Cash and Securities in Sinking and Redemption Funds....	
Cash and Securities in Insurance Reserve Fund.....	
Sundry Accounts .....	
	<i>Appropriated Surplus.</i>
	Additions to Property through Income since June 30, 1907
	Reserve Invested in Sinking Fund .....
	Reserve Invested in Other Reserve Funds .....
	<b>Profit and Loss Balance.....</b>
<b>Total .....</b>	<b>Total .....</b>

This Company is also liable as a guarantor of the following securities in hands of the public—  
 The Chesapeake and Ohio Grain Elevator Co., First Mortgage 4½% Bonds due 1938 \$820,000.00  
 Norfolk Terminal and Transportation Co., First Mortgage 5% Bonds due 1948 500,000.00  
 Western Pocahontas Corporation, First Mortgage 4½% Bonds due 1945 750,000.00

Western Pocahontas Corporation, Extension Mortgage No. 1, 4½% Bonds due 1945 33,000.00  
 Western Pocahontas Corporation, Extension Mortgage No. 2, 4½% Bonds due 1946 51,000.00  
 Louisville and Jeffersonville Bridge Co. Mortgage (C. & O. Prop'n, ¼) 4½% Bonds due 1943 300,000.00  
 Richmond-Washington Co. Collateral Trust Mortgage (C. & O. Prop'n, 1/6) 4½% Bonds due 1943 1,000,000.00

For the reasons cited the revenues and expenses and operating conditions experienced adverse results, as reflected in the following table:

	1913	1912	Increase or Decrease
Operating revenues	\$35,085,278.32	\$34,289,869.77	\$795,408.55
Net operating revenue	\$10,633,718.01	\$11,654,188.73	-\$1,020,470.72
Operating ratio	69.7%	66.0%	3.7%
Tons of revenue freight carried one mile	6,694,879,287	6,692,114,437	2,764,850
Revenue train load, tons	843	756	87
Revenue tons per loaded car	29.8	30.3	-.5

As a result of the recent decision of the Supreme Court of the United States in the case involving the validity of the two cent passenger rate law passed by the Legislature of West Virginia in February, 1907, it will be necessary for your Company to pay the coupons issued during the period of the litigation, and under the direction of the West Virginia courts a commission has been appointed to receive and verify such coupons as presented. The two cent rate is now in force in West Virginia in pursuance of this decision.

In order to aid in preserving your Company's record for safety and to reduce the chance for casualties, safety committees have been organized among the employees and the operating staff.

Extensions of the Cabin Creek, Coal River and Guyandot Valley (Rum Creek) branches aggregating 18.5 miles have been completed. The Piney River & Paint Creek R. R., 6.6 miles, and the Price Hill Division of the White Oak Ry., 2.3 miles, have been leased jointly by this Company and the Virginian Ry. and are operated by your Company. The Wolf Creek branch of the White Oak Ry. and the "Bishop Connection" between the White Oak Ry. and the Virginian Ry., 8 miles, have also been leased jointly by your Company and the Virginian Ry. and are operated by the Virginian Ry. Trackage rights were secured by your Company over 10.1 miles of the Virginian Ry. and similar rights granted the Virginian Ry. over 11.5 miles of line on Raleigh & Southwestern and Piney Creek branches.

The coal and coke tonnage was 16,363,178, a decrease of 9.5 per cent.; other freight tonnage was 8,811,063, an increase of 9.2 per cent. Total tonnage was 25,174,241 tons, a decrease of 3.7 per cent. Freight revenue was \$27,549,696.17, an increase of 1.1 per cent. Freight train mileage was 7,937,054 miles, a decrease of 10.3 per cent. Revenue ton miles were 6,694,879,287, an increase of less than 0.1 per cent. Ton mile revenue was 4.12 mills, an increase of 1.2 per cent. Revenue per freight train mile was \$3.47, an increase of 12.6 per cent. Revenue tonnage per train mile was 843 tons, an increase of 11.5 per cent.; including Company's freight, the tonnage per train mile was 901 tons, an increase of 14.3 per cent. Tonnage per locomotive, including Company's freight, was 790 tons, an increase of 15.5 per cent. Revenue tonnage per loaded car was 29.8 tons, a decrease of 1.7 per cent. Tons of revenue freight carried one mile per mile of road were 2,886,968, a decrease of 2.4 per cent.

There were 5,859,447 passengers carried, an increase of 6.7 per cent. The number carried one mile was 267,044,325, an increase of 5.8 per cent. Passenger revenue was \$5,858,138.22, an increase of 6.4 per cent. Revenue per passenger per mile was 2.194 cents, an increase of 0.6 per cent. Number of passengers carried one mile per mile of road was 115,155, an increase of 3.3 per cent. Passenger train mileage was 5,221,099, an increase of 2.3 per cent. Passenger revenue per train mile was \$1.12.2, an increase of 4.0 per cent.; including mail and express, it was \$1.31.1, an increase of 3.6 per cent. Passenger service train revenue per train mile was \$1.34.8, an increase of 3.8 per cent.

There were 12,574 tons of new rails (5,329 tons 100 pounds and 7,335 tons 90 pounds), equal to 85.2 track miles, used in the renewal of existing main tracks.

The average amount expended for repairs per locomotive operated was \$2,623.88; per passenger train car \$843.75; per freight train car \$70.11.

Mr. Frederick H. Rawson was elected a director at the annual meeting on October 22, 1912, in place of General Thos. H. Hubbard, resigned. April 1, 1913, Mr. Carl Remington was appointed Secretary of the Company in place of Mr. Jas. Stuart MacKie resigned, Mr. MacKie continuing as Treasurer of the Company under previous appointment.

The Board takes this occasion to make due and fitting acknowledgment to officers and employees for faithful and efficient services performed during the year.

By order of the Board of Directors.

GEO. W. STEVENS,  
President.

FRANK TRUMBULL,  
Chairman.

GENERAL INCOME ACCOUNT.

For Year ended June 30, 1913, and Comparison with Year ended June 30, 1912.

TABLE 2.

	1913.	1912.	Increase or Decrease.
<b>OPERATING REVENUES.</b>			
From Freight Traffic	\$27,549,696.17	\$27,261,474.53	\$ 288,221.64
" Passenger Traffic	5,858,138.22	5,505,536.22	352,602.00
" Transportation of Mails	386,639.91	371,137.09	15,502.82
" Transportation of Express	599,344.74	586,021.42	13,323.32
" Other Transportation	396,998.48	323,569.13	73,409.35
" Non-Transportation	294,480.80	242,131.38	52,349.42
<b>Total Operating Revenues</b>	<b>\$35,085,278.32</b>	<b>\$34,289,869.77</b>	<b>\$ 795,408.55</b>
<b>OPERATING EXPENSES.</b>			
For Maintenance of Way and Structures	\$ 4,342,744.60	\$ 3,981,645.67	\$ 361,098.93
" Maintenance of Equipment	7,275,439.48	6,724,459.75	550,979.73
" Traffic	669,016.32	636,966.92	32,049.40
" Transportation	11,380,998.32	10,503,415.25	877,583.07
" General	783,361.59	789,193.45	-5,831.86
<b>Total Operating Expenses</b>	<b>\$24,451,560.31</b>	<b>\$22,635,681.04</b>	<b>\$ 1,815,879.27</b>
<b>Net Operating Revenue</b>	<b>\$10,633,718.01</b>	<b>\$11,654,188.73</b>	<b>-\$1,020,470.72</b>
<b>INCOME FROM OTHER SOURCES:</b>			
Hire of Equipment	\$ 598,740.44	\$ 411,391.54	\$ 187,348.90
Interest from Investments	1,319,924.00	1,083,225.91	236,698.09
Interest, General Account	2,404.25	49,159.61	-46,755.36
Miscellaneous	304,468.11	264,785.84	39,682.27
	\$ 2,225,536.80	\$ 1,808,562.90	\$ 416,973.90

Gross Income	\$12,859,254.81	\$13,462,751.63	\$ 603,496.82
<b>DEDUCTIONS FROM INCOME:</b>			
Interest on Funded Debt	\$ 7,102,563.04	\$ 7,045,261.67	\$ 57,301.37
Interest on Equipment Trusts	216,595.40	297,044.82	-80,449.42
Taxes	1,375,862.89	1,014,219.94	361,642.95
Rentals, Leased Roads, Joint Tracks, &c.	883,223.55	775,364.55	107,859.00
Loss on C. & O. Grain Elevator	Cr. 17,493.45	56,654.62	-74,148.07
<b>Total deductions</b>	<b>\$ 9,560,751.43</b>	<b>\$ 9,188,545.60</b>	<b>\$ 372,205.83</b>
<b>NET INCOME</b>	<b>\$ 3,298,503.38</b>	<b>\$ 4,274,206.03</b>	<b>\$ 975,702.65</b>
Amount to credit of Profit and Loss June 30, 1912			\$2,760,398.49
Amount of Net Income for year ended June 30, 1913, transferred to Profit and Loss			3,298,503.38
			<b>\$6,058,901.87</b>

Deduct:

Dividend No. 24 of 1 1/4% paid September 30, 1912	\$784,770.00
Dividend No. 25 of 1 1/4% paid December 31, 1912	784,770.00
Dividend No. 26 of 1 1/4% paid March 31, 1913	784,770.00
Dividend No. 27 of 1 1/4% paid June 28, 1913	784,770.00
	<b>\$3,139,080.00</b>

Discount on Securities sold during year, and sundry adjustments	405,141.09
<b>Balance to credit of Profit and Loss June 30, 1913</b>	<b>\$2,514,680.78</b>

COST OF PROPERTY JUNE 30, 1913.

TABLE 4.  
The Cost of Road as of June 30, 1912, was \$166,424,404.04

ADDED FOR:	
Additions and Betterments during year ended June 30, 1913:	
Branch Lines	\$175,032.77
New Second Track	123,738.85
Changes of Line and Track Elevation	18,010.73
Sidings and Yards	583,841.61
Depot and Office Building, Huntington, W. Va.	97,179.71
Depots at various places	36,824.61
Shop Buildings at various places	50,561.76
New Coal Pier (No. 9), Newport News, Va.	358,083.78
Additions to Piers, Newport News, Va.	37,075.98
Water and Coaling Stations	161,010.52
Renewing and Strengthening Bridges and Filling Trestles	453,867.96
Electric Light and Power Plants	6,309.97
Track Scales	12,289.94
Telephone Lines for Dispatching Trains	19,383.13
Interlocking, Block and Other Signals	71,407.72
Various Other Structures	88,305.30
Shops, Machinery and Tools	67,904.72
General Office Furniture and Equipment, Richmond, Va.	40,229.90
Real Estate	15,856.55
Fencing Right of Way	7,214.65
Improved Rail and Track Appliances	144,888.12
Increasing width of Road-bed and Ballasting	249,622.83
Concrete Mixer	1,321.70
	<b>\$2,819,962.82</b>

Deferred payments account of acquisition of Chicago Line	13,500.00
Virginia Air Line Railway (taken over by deed July 12, 1912)	1,071,947.12
Purchase of Securities of Subsidiary Companies	270.00
	<b>3,905,679.94</b>

Cost of Road, June 30, 1913. \$170,330,083.98

The Cost of Equipment as of June 30, 1912, was \$33,204,770.06

ADDED FOR:	
Equipment purchased during year ended June 30, 1913:	
1 Consolidation Locomotive	\$12,191.95
1 Switching Locomotive	6,000.00
2 Mogul Locomotives, received from Virginia Air Line Ry.	21,000.00
Adjustment of Cost 1 Mikado Locomotive acquired in previous year	Cr. 22.25
3 Passenger Cars	4,721.89
8 Gondolas	7,876.15
3 Work Cars	1,804.14
1 Mahoney Ditching Machine	2,900.00
1 Business Car (No. 9)	32,569.77
1 Electric Motor Passenger Car	12,656.42
1 Car Float	81,810.00
6 Freight Cars and 1 Work Car, previously written off, returned to service	3,793.79
Improvement of Equipment	145,762.09
	<b>\$333,063.95</b>

Less:	
Value of Equipment retired	\$828,640.98
	<b>\$495,577.03</b>

Cost of Equipment June 30, 1913 \$32,709,193.03

Total Cost of Road and Equipment \$203,039,277.01

Amount deducted from Cost of Road and Equipment on account of difference between face value of securities of auxiliary companies and the prices at which they were taken over 1,277,300.00

Cost of Road and Equipment June 30, 1913, as per Balance Sheet \$201,761,977.01

THE HOCKING VALLEY RAILWAY COMPANY.—FOURTEENTH ANNUAL REPORT.

COLUMBUS, Ohio, September 24, 1913.

TO THE STOCKHOLDERS:

The Fourteenth Annual Report of the Board of Directors, for the fiscal year ended June 30, 1913, is herewith submitted.  
The average mileage operated during the year was 351.5 miles, an increase over the previous year of 0.2 miles. The mileage at the end of the year was 351.5 miles. See schedule on page 8.

RESULTS FOR THE YEAR.

Operating Revenues were .....	\$7,817,643.86
(Increase \$513,964.45 or 7.04%.)	
Operating Expenses were .....	4,983,843.12
(Increase \$404,800.96 or 8.84%.)	
Net Operating Revenue was.....	\$2,833,800.74
(Increase \$109,163.49 or 4.01%.)	
Taxes were .....	477,900.00
(Increase \$63,711.68 or 15.38%.)	
Operating Income, Taxes deducted, was.....	\$2,355,900.74
(Increase \$45,451.81 or 1.97%.)	
Miscellaneous Income was .....	772,478.57
(Increase \$78,322.92 or 11.28%.)	
<b>Rentals and other payments were.....</b>	<b>\$3,128,379.31</b>
(Decrease \$4,649.92 or 4.54%.)	
Income for the year available for interest was.....	\$3,030,573.90
(Increase \$128,424.65 or 4.43%.)	
Interest (36.76% of amount available) amounted to.....	1,114,170.00
(Increase \$42,857.01 or 4.00%.)	
Net Income for the year was.....	\$1,916,403.90
(Increase \$85,567.64 or 4.67%.)	
Dividends paid during the year:	
Four Dividends of 1 3/4% on Capital Stock.....	\$769,965.00
One Extra Dividend of 4 1/2% on Capital Stock..	494,977.50
(Increase \$494,942.50 or 64.28%.)	
<b>Remainder, devoted to improvement of physical and other assets .....</b>	<b>\$651,461.40</b>

FINANCIAL.

The reduction in funded debt shown by balance sheet of June 30, 1913, as compared with June 30, 1912, resulted from the annual payments of \$316,000 on equipment trusts.

An analysis of the property accounts will be found on pages 12 and 13, by reference to which it will be seen that additions and betterments were made during the year to the amount of \$859,531.22, of which \$684,038.45 was added to cost of road, and \$175,492.77 was added to equipment account.

During the past four years your Company's expenditures for equipment and other additions and betterments have been as follows:  
Additional equipment acquired (less retirements).....\$1,087,612.53  
Additions and Betterments.....2,137,254.81

GENERAL REMARKS.

The equipment in service June 30, 1913, consisted of:

Locomotives owned .....	149	Increase	3
Passenger train cars owned.....	88	Increase	6
Freight train and miscellaneous cars owned.....	9,428	Decrease	1,568
Freight train cars leased under Equipment Trusts...	3,350		
<b>Total Freight Train Cars.....</b>	<b>12,778</b>	<b>Decrease</b>	<b>1,568</b>

\$3,224,867.34

The decrease in freight train cars is due to the continued retiral of light capacity equipment begun two years ago. 588 fifty-ton gondola cars were added during the year and 1,000 steel gondola cars of 115,000 pounds capacity have been contracted for early delivery.

During the latter part of March and first part of April unprecedented floods in the Scioto, Olentangy, Hocking and Ohio rivers damaged your Company's property and resulted in temporary suspension of through traffic on all lines in the territory affected. In spite of the affliction caused by the flood, the following results have been achieved:

	1913.	1912.	Increase.
Operating revenues .....	\$7,817,643.86	\$7,303,679.41	\$513,964.45
Net operating revenue.....	2,833,800.74	2,724,637.25	109,163.49
Tons of revenue freight carried			
one mile .....	1,453,682.875	1,377,072.118	76,610.757
Revenue train load, tons.....	988	852	136
Revenue tons per loaded car.....	36.3	35.3	1.0

Fifteen receiving tracks were built and a water station and treating plant was erected at Parsons yard near Columbus. The work of separating the grades at South Columbus, required by the city authorities of Columbus, is nearly completed. Twenty-three passing tracks on the Toledo Division were extended an aggregate of 4.31 miles. Bridges at LeMoyné, Marion, Olentangy and Big Walnut were replaced with modern steel structures of heavy capacity.

The construction of a new coal dock and terminal yard on the east side of the Maumee River at Toledo, opposite the present dock of your Company, has been undertaken during the year in order to facilitate and increase the handling of coal for shipment to ports on the Great Lakes.

The coal and coke tonnage was 7,964,314 tons, an increase of 3.5%. Other freight tonnage was 3,214,322 tons, an increase of 23.7%. Total tonnage was 11,178,636 tons, an increase of 8.6%. Freight revenue was \$6,365,734.99, an increase of 6.8%. Freight train mileage was 1,471,616 miles, a decrease of 9%. Revenue ton miles were 1,453,682.875, an increase of 5.6%. Ton mile revenue was 4.38 mills, an increase of 1.2%. Revenue per freight train mile was \$4.32.6, an increase of 17.4%. Revenue tonnage per train mile was 988 tons, an increase of 16%; including Company's freight, the tonnage per train mile was 1,023 tons, an increase of 15.9%. Tonnage per locomotive, including Company's freight, was 862 tons, an increase of 10.8%. Revenue tonnage per loaded car was 36.3 tons, an increase of 2.8%. Tons of revenue freight carried one mile per mile of road was 4,135.655, an increase of 5.5%.

There were 2,277,140 passengers carried, an increase of 157 passengers. The number of passengers carried one mile in steam trains was 52,628,498, an increase of 1.1%. Passenger revenue was \$929,990.92, an increase of 6.3%. Revenue per passenger per mile on steam trains was 1.721 cents, an increase of 5.7%. The number of passengers carried on steam trains one mile per mile of road was 149,725, an increase of 1.0%. Passenger train mileage of steam trains was 815,611, a decrease of 2.3%. Passenger revenue per train mile of steam trains was \$1.11.1, an increase of 9.5%; including mail and express it was \$1.27.7, an increase of 7.9%. Passenger service train revenue per train mile was \$1.32.7, an increase of 7.5%.

There were 3,793 tons of new 90-lb. rails, equal to 26.8 track miles, used in the renewal of existing main tracks.

The average amount expended for repairs per locomotive was \$2,254.19; per passenger train car \$535.85; per freight train car \$55.36.

On November 21, 1912, Gen. Thomas H. Hubbard resigned as a member of the Board and Mr. Henry E. Huntington was elected in his stead.

On May 15, 1913, Mr. F. J. Reynolds was elected a Director to take the place made vacant by the death of Mr. S. C. Reynolds.

Effective April 1, 1913, Mr. Jas. Steuart MacKie resigned as Secretary

CONDENSED BALANCE SHEET, JUNE 30, 1913.

ASSETS.		LIABILITIES.	
<i>Property Investment.</i>		<i>Capital Stock .....</i>	\$11,000,000.00
Cost of Road .....	\$28,463,679.51	<i>Funded Debt.</i>	
Cost of Equipment.....	11,776,759.38	First Consolidated Mortgage	
	\$40,240,438.89	4 1/2% Bonds, 1909.....	\$16,044,000.00
Reserve for Accrued Depreciation of Equipment—Cr.....	878,206.01	First Mortgage C. & H. V. R. R.	
	\$39,362,232.88	4% Bonds, 1948.....	1,401,000.00
<i>Securities of Proprietary, Affiliated and Controlled Companies—Pledged.</i>		First Mortgage Cols. & Tol. R. R. 4% Bonds, 1955.....	2,441,000.00
Stocks .....	\$308,088.66	H. V. Ry. Co. 4 1/2% Gold Notes, 1913 .....	4,000,000.00
Bonds .....	300,000.00		\$23,886,000.00
	608,088.66	Equipment Trust Obligations..	1,339,000.00
<i>Other Investments.</i>			25,225,000.00
Miscellaneous Investments—Securities—Pledged .....	1,391,718.24		\$36,225,000.00
	\$41,362,039.78	<i>Working Liabilities.</i>	
<i>Working Assets.</i>		Traffic Balances .....	\$507,203.89
Cash .....	\$1,529,163.96	Audited Vouchers and Wages Unpaid .....	873,654.30
Loans and Bills Receivable...	102,811.78	Miscellaneous Accounts Payable .....	63,300.52
Traffic Balances .....	94,728.04	Matured Interest, Dividends and Rents Unpaid .....	374,115.25
Agents and Conductors.....	431,825.85	Other Working Liabilities....	28,217.95
Miscellaneous Accounts Receivable .....	623,375.71		\$1,846,491.91
Other Working Assets .....	4,867.05	<i>Deferred Liabilities.</i>	
	\$2,786,772.39	Unmatured Interest, Dividends and Rents Payable.....	\$103,979.99
Materials and Supplies.....	664,684.75	Taxes Accrued .....	307,779.89
<i>Securities in Treasury—Unpledged.</i>		Operating Reserves .....	43,990.88
Stocks .....	\$501.00	Other Deferred Credit Items.....	62,780.38
Bonds .....	2,785,000.00		518,531.14
	2,785,501.00	<i>Appropriated Surplus.</i>	
<i>Deferred Assets.</i>		Additions to Property through Income since June 30, 1907 (to June 30, 1909) .....	\$181,409.11
Unmatured Interest .....	\$35,312.50	Reserve Invested in Sinking Fund .....	169,370.90
Advances to Proprietary, Affiliated and Controlled Companies .....	14,055.29	Reserve Invested in Insurance Fund .....	31,626.15
Advances, Working Funds....	684.02		\$382,406.16
Insurance, paid in advance...	4,643.35	<i>Profit and Loss—Balance.....</i>	8,769,855.20
Cash and Securities in Sinking and Redemption Funds....	36,267.32		9,152,261.36
Cash and Securities in Insurance Fund .....	31,626.15		
Other Deferred Debit Items..	20,697.86		
	143,286.49		
	6,380,244.63		
<b>Total .....</b>	<b>\$47,742,284.41</b>	<b>Total .....</b>	<b>\$47,742,284.41</b>

This Company, jointly with the Toledo and Ohio Central Railway Company, guaranteed in 1901 5% First Mortgage Bonds of the Kanawha and Hocking Coal and Coke Company due 1951 (\$2,926,000. outstanding), and in 1902 5% First Mortgage Bonds of the Continental Coal Company due

1952 (\$1,762,000. outstanding). The Ohio courts, in quo warranto proceedings in which bondholders were not represented, have pronounced these guaranties *ultra vires*.





Dividend Appropriations of Surplus:	
On \$20,000,000 Preferred Stock—	
1¼% Payable Oct. 15, 1912.	} \$1,000,000.00
1¼% Payable Jan. 15, 1913.	
1¼% Payable Apr. 15, 1913.	
1¼% Payable July 15, 1913.	
Less Dividends on Stock held by Company .....	5,317.52
	\$ 994,682.48
Appropriations of Surplus for Additions and Betterments .....	163,110.61
Funded Debt Discount Extinguished through Surplus .....	220,110.00
Loss on Retired Road and Equipment:	
Road .....	\$9,926.23
Equipment .....	33,659.34
	43,585.57
Miscellaneous Debits .....	9,099.20
Balance, Credit, June 30, 1913, Carried to General Balance Sheet .....	4,873,538.91
Total .....	\$6,304,126.77

RAIL OPERATIONS—REVENUES.

The total revenues from operation for the fiscal year amounted to \$13,296,949.59, an increase over the previous year of \$1,254,406.88, or 10.42 per cent. The net revenue from operations increased \$458,024.86, or 12.64 per cent.

Freight revenue increased \$893,375.17, or 9.96 per cent. General business conditions were very satisfactory during the year and, with exceptionally good cotton, grain and fruit crops, resulted in a very substantial increase in the tonnage movement over the line.

Passenger revenue increased \$317,190.51, or 13.78 per cent, which is attributed to the healthy business conditions prevailing during the year.

AGRICULTURAL AND INDUSTRIAL.

The steady and healthy growth of the territory contiguous to this line is manifested by the agricultural activity prevailing generally. As timber is cut out, the fertile and productive land is being converted into farms, and farm products are taking the place of forest products. This activity has resulted in more and better schools, improved streets and sanitary conditions in the cities and towns, an improvement in drainage, the construction and improvement of county roads, and a general betterment in living conditions.

The peach crop of 1912 was the greatest in the history of that industry in East Texas; about 2,730 cars being handled by this line. Corn and cotton were above the average both in yield and quality. The damage to the cotton crop from boll weevil was, in most sections, very light, but the injury from the fall army worm was considerable in several localities, although the farmers are learning to employ poisons to combat this pest.

The cultivation of rice in Arkansas continues to receive unusual attention and there has been a steady increase in the acreage of this commodity since its original introduction in that State a few years back. The success of this industry is in many instances phenomenal, some of the yields during the past year averaging as high as one hundred bushels per acre. The cost of production is comparatively light and the margin of profit exceptionally large. The acreage devoted to rice in Arkansas during the past season was reported at 86,000 acres, and the estimate for the ensuing season is approximately 100,000 acres. Many rice planters are practicing crop rotation and devoting considerable of their rice lands to general farm crops.

The Agricultural and Industrial Department is giving special attention to educational work amongst farmers along the line. This work is being conducted in the form of personal visits to the farms, by holding farmers' meetings, publishing special bulletins and operating demonstration cars, all in co-operation with the United States Department of Agriculture and the local agricultural colleges and experimental stations. Methods of cultivation are gradually changing from the all-cotton and corn system to diversified crops. This is due to the various educational influences, as well as to the introduction of new people from the older farming sections of the country, who bring with them improved equipment and advanced ideas of cultivating the soil.

The industrial development has kept pace with the agricultural and general business development, and a number of new industries have been located along this line during the past year.

RATE LITIGATION.

The rate litigation with the State of Missouri, in which this company with seventeen other Missouri carriers, contested, on the grounds of confiscation, the validity of an Act of the Legislature passed February 27, 1907, fixing a maximum passenger fare within the State of two cents a mile, and an Act passed March 19, 1907, prescribing maximum intrastate rates on certain specified commodities in carload lots, was decided by the Supreme Court of the United States on June 16, 1913, adversely to the Company. The passenger and freight tariffs of the company have been revised to comply with the mandate of the Court and the two cent per mile passenger rate and the freight rates promulgated by the State Commission are now in effect.

Likewise the rate litigation with the State of Arkansas, in which this company and the St. Louis, Iron Mountain and Southern Railway Company, contested, on the grounds of confiscation, the validity of an Act of the Legislature passed on February 9, 1907, fixing the maximum passenger fare within the State at two cents per mile, and Standard Distance Tariff No. 3 promulgated by the Railroad Commission of Arkansas prescribing maximum intrastate freight rates for all classes of commodities, was, on June 16, 1913, decided adversely to the two companies by the Supreme Court of the United States. In conformity with the mandate of the Court the passenger and freight tariffs of the company have been revised and a two cent per mile passenger rate and the freight rates promulgated by the State Commission are now in effect.

It is difficult, at this time, to estimate to what extent the revenues of the company will be affected by the foregoing decisions but it is hoped good cotton and other crops, with the attending stimulus in business, will in a large measure offset the losses resulting from these rate reductions. Furthermore, it is believed that this company and other carriers similarly situated will at some future time be able to produce evidence sufficient to convince the State authorities of the inadequacy of the rates prescribed by them, which rates are in effect under protest of the carriers.

RAIL OPERATIONS—EXPENSES.

During the fiscal year ended June 30, 1913, the total expenses of operation show an increase of \$796,382.02, or 9.46 per cent., as compared with the preceding year. The per cent. of expenses of operation to revenues from operation was 69.31 per cent. as against 69.92 per cent. for the preceding year, or a decrease of .61 of one per cent.

The general operating expense accounts show an increase over the preceding year as follows:

Maintenance of Way & Structures.....	\$422,414.37 or 28.60%
--------------------------------------	------------------------

Maintenance of Equipment .....	47,120.44 or 2.17%
Traffic Expenses .....	29,740.40 or 6.21%
Transportation Expenses .....	295,270.78 or 7.89%
General Expenses .....	1,836.03 or 0.33%

In Exhibit "B," on pages 26 and 27, will be found a comparison of operating expenses in detail, by primary, as well as by general accounts.

TRAIN AND CAR LOADING.

The following tables show the average load per freight train and per loaded freight car for the past ten years.

Average load, in tons, per loaded car (including company material).			
Year ended	St. L. S-W. Ry. Co.	St. L. S-W. Ry. Co.	Entire System.
June 30.		of Tex.	
1904	18.29	15.62	17.43
1905	18.19	15.54	17.43
1906	18.79	16.63	18.13
1907	19.01	17.06	18.40
1908	19.25	17.34	18.69
1909	17.84	16.67	17.49
1910	18.58	16.89	18.14
1911	18.78	17.30	18.32
1912	18.02	16.44	17.54
1913	18.36	16.44	17.78

Average load, in tons, per train (including company material).			
Year ended	St. L. S-W. Ry. Co.	St. L. S-W. Ry. Co.	Entire System.
June 30.		of Tex.	
1904	387.65	172.20	284.72
1905	385.02	177.33	295.50
1906	415.15	194.49	315.06
1907	425.92	202.81	323.35
1908	407.61	189.99	311.19
1909	394.23	190.34	301.61
1910	434.16	196.27	326.11
1911	423.70	200.04	320.16
1912	447.25	211.19	340.58
1913	461.11	214.50	349.49

EQUIPMENT.

The following equipment, contracted for during the preceding year, was received during the current year: 18 consolidated locomotives, 4 mogul switch engines, 10 steel baggage cars and 10 steel combination baggage and mail cars. This equipment was paid for from the proceeds of sale of First Terminal and Unifying Mortgage Bonds issued for that purpose.

During the fiscal year there was purchased for cash, and built at company shops, from current funds, equipment as follows: 2 official cars, 5 automobile cars, 22 cabooses, 29 box cars, 2 stock cars, 6 flat cars, 1 ballast car, 30 air dump cars, 2 wreckers, 1 ladderwork unloader, 2 boarding cars, 1 dirt spreader, 1 steam wrecker, 3 wreck tool cars, 1 motor-gar car and 1 school-of-instruction car.

There was contracted for under trust agreement with the Philadelphia Trust, Safe Deposit & Insurance Co., executed June 1, 1913, 10 consolidation locomotives, 10 ten-wheel locomotives, 3 steel underframe dining cars, 2 steel underframe parlor cars and 200 general service steel underframe coal cars. Of this equipment, there was delivered and received up to June 30, 1913, the 3 steel underframe dining cars; the locomotives have been received since the close of the fiscal year; the 2 steel underframe parlor cars and the 200 general service steel underframe coal cars are to be delivered during October, 1913.

ADDITIONS AND BETTERMENTS.

Expenditures for Additions and Betterments—Road, during the current year amounted to \$1,372,990.73 and for Equipment, after allowing for value of equipment retired, \$716,134.75, making a total amount expended for additions and betterments during the year \$2,089,125.48.

The work of double tracking certain portions of the line between Illmo, Mo., and Paragould, Ark., is under way, and, at the close of the fiscal year 7.4 miles of second track had been placed in service. Likewise the work of extending all passing tracks between these points is also in progress. These extended passing tracks will, in the future, be available as parts of the second main track. The line between Illmo and Rockview, a distance of 7.4 miles is used by the St. Louis, Iron Mountain & Southern Ry. Co. and the Chicago & Eastern Illinois R. Co., and between Rockview and Paragould, a distance of 102.9 miles by the St. Louis, Iron Mountain & Southern Ry. Co. under joint trackage agreements. These portions of the line accommodate a heavy traffic movement and the completion of this work, now under way, will greatly facilitate the operation of trains thereon.

The exhibit styled "Property Investment—Road and Equipment" on page 31, shows, in detail, the expenditures for additions and betterments during the current fiscal year.

NEW BRIDGE OVER THE MISSISSIPPI RIVER AT MEMPHIS, TENN.

The Arkansas & Memphis Railway, Bridge and Terminal Company has been organized for the purpose of constructing, maintaining and operating a double track railway and highway bridge over the Mississippi river at Memphis, Tenn. Under a contract between the Chicago, Rock Island and Pacific Railway Company, St. Louis, Iron Mountain and Southern Railway Company and this Company, dated May 14, 1913, the execution of which was authorized by the Board of Directors at a special meeting held on April 28, 1913, each of the three companies agrees to subscribe in equal proportions to the capital stock of the new Bridge Company. The construction, maintenance and operation of this bridge was authorized by Act of Congress July 20, 1912, amended August 23, 1912. Property for the approaches has been acquired, preliminary plans have been drawn, work has been commenced and the bridge will be pushed to completion as rapidly as possible.

FREIGHT HOUSE, TEAM TRACKS, ETC., AT ST. LOUIS, MO.

A new freight house and auxiliary facilities, at St. Louis, Mo., were completed and placed in service January 1, 1913. The completeness of these facilities and their accessibility to the shipping public has already resulted in a substantial traffic increase to and from the City of St. Louis.

NEW PASSENGER TERMINALS AT DALLAS, TEXAS.

Franchises have been obtained and property secured by the Union Terminal Company, Dallas, Texas, for the purpose of constructing a union passenger station and facilities therefor. The new terminal company has been organized by all lines entering the City of Dallas. The St. Louis Southwestern Ry. Co. of Texas owns a one-eighth proprietary interest in these new terminals and will make use of the facilities when completed in the operation of its passenger trains to and from Dallas.

FREIGHT TERMINALS AT FT. WORTH, TEXAS.

As stated in the preceding annual report, a desirable location in Ft. Worth, Texas, has been obtained on which to construct a freight house, team tracks, etc. Grading has been commenced and construction work is now under way on these terminals.

# Railway Age Gazette

PUBLISHED EVERY FRIDAY AND DAILY EIGHT TIMES IN JUNE, BY THE SIMMONS-BOARDMAN PUBLISHING COMPANY, WOOLWORTH BUILDING, NEW YORK.

CHICAGO: Transportation Bldg. CLEVELAND: Citizens' Bldg.  
LONDON: Queen Anne's Chambers, Westminster.

E. A. SIMMONS, *President.*

L. B. SHERMAN, *Vice-President.* HENRY LEE, *Sec'y & Treas.*  
The address of the company is the address of the officers.

### EDITORS.

SAMUEL O. DUNN, *Editor.*

ROY V. WRIGHT, <i>Managing Editor.</i>	H. H. SIMMONS	E. S. FAUST
W. E. HOOPER	H. F. LANE	F. W. KRAEGER
B. B. ADAMS	E. A. AVERILL	A. D. CLOUD
E. T. HOWSON	R. E. THAYER	GEORGE L. FOWLER
	A. C. LONDON	

Subscriptions, including 52 regular weekly issues and special daily editions published from time to time in New York, or in places other than New York, payable in advance and postage free:

United States and Mexico.....	\$5.00
Canada .....	6.00
Foreign Countries (excepting daily editions).....	8.00
Single Copies .....	15 cents each

Engineering and Maintenance of Way Edition and four Maintenance of Way Convention Daily issues, North America, \$1.00; foreign, \$2.00.

Entered at the Post Office at New York, N. Y., as mail matter of the second class.

WE GUARANTEE that of this issue 8,150 copies were printed; that of those 8,150 copies, 6,611 were mailed to regular paid subscribers and 845 were provided for counter and news companies' sales; that the total copies printed this year to date were 361,508—an average of 8,077 copies a week.

VOLUME 55. OCTOBER 17, 1913. NUMBER 16.

## CONTENTS

### EDITORIAL:

Editorial Notes .....	687
The Agitation for Government Ownership of Railways.....	688
Adjuvative Safeguards .....	689
*Missouri Pacific .....	689, 737
*Chicago, Rock Island & Pacific.....	691, 733
*Southern Railway .....	692, 729
New Books .....	694

### LETTERS TO THE EDITOR:

The Santa Fe Loss and Damage Committee; by H. G. Krake.....	694
---	-----

### MISCELLANEOUS:

The Flagging Rule and Its Enforcement.....	695
*Diesel Locomotive .....	697
*Renewing Two Double Track Swing Spans.....	699
Wartime Railroading in Mexico; by Major Charles Hine.....	702
*Record of a Lehigh Valley Locomotive.....	704
Railway Fire Protection Association .....	705
Conditions of Competition for the E. H. Harriman Memorial Gold Medal .....	708
*B. & O. Engine Terminal at Cumberland, Md.....	709
*Air Brake Hose; by J. S. Sheafe.....	711
*Small Motor-Driven Ventilating Sets for Buildings.....	712
*New Power Reverse Gear.....	713
Foreign Railway Notes.....	694, 698, 703, 711, 712, 713

GENERAL NEWS SECTION.....	714
---------------------------	-----

\*Illustrated.

THE stand taken by Governor Foss of Massachusetts in regard to the threatened strike of locomotive enginemen on the New Haven is, considering the governor's position before the public, as novel and refreshing as it is unexpected. The men are threatening to strike because the management of the railway has announced new rules making fitness the first qualification for the promotion of enginemen or their assignment to special runs. Governor Foss is a candidate for re-election. In the United States when a man is running for office he remains silent concerning controversies between railways and their employees or goes over bag and baggage to the employees. Governor Foss, on the contrary, has come out flatly against a strike on the ground that the public welfare is entitled to the first consideration, and that from the standpoint of the public the pro-

posed strike would not be justifiable. Governor Foss has shown that he is an astute politician, and the position he has assumed may be as significant of a changing public opinion as it is creditable to him. It seems quite possible that his course may be, in some measure, attributable to a belief on his part that the public is growing less patient with such labor union unreasonableness as is now being exhibited in New England. At any rate, it would appear that it can be but a matter of time until the public will be brought to realize that the truly faithful public servant is the one who will oppose the unreasonable demands of organized labor just as vigorously and courageously as he will oppose the unreasonable conduct of organized capital.

THE retirement of Major Hine as vice-president of the Southern Pacific Lines in Mexico and of the Arizona Eastern to return to the field of expert railway work marks the complete severance of his connection with what were formerly the Harriman Lines. Doubtless his retirement is largely due to the unsettled conditions in Mexico, which so seriously interfere with satisfactory railway operation in that country. Major Hine's work in connection with the adoption of the Hine unit system on the Harriman Lines has become famous throughout the world of railroading. The Hine system of organization has not received as wide and permanent adoption as its originator probably hoped for; but his labors have, nevertheless, been fruitful. They have caused great attention to be directed toward the subject of railway organization—a matter to which not enough attention had been given. Many railway organizations had “just grown”; and it was impossible that railway managers should begin to analyze them without detecting many of their defects and weaknesses. In consequence, since Major Hine began his work on the Harriman Lines, there have been changes in the organizations, not only of those lines, but of many others; and in numerous cases they have been similar in nature, although not in outward form, to those Major Hine has advocated. It is perhaps fortunate for the railways that Major Hine has returned to the expert field; for there is need for men who have both his theoretical and practical equipment constantly to direct the attention of railway managements toward various phases of organization and efficiency. While practical railway men always have a tendency to stamp as “theorists” those who want to change things around, they can hardly help listening with respect to one who not only has a stock of theories and principles to advance and defend, but who is prepared to back them up with an experience gained as brakeman, switchman, conductor, yardmaster, trainmaster, general superintendent, general manager and vice-president; and while few persons greatly relish criticism of the way they do things, all persons who are worth striving with are benefited by receiving criticism from intelligent sources.

THE appointment of Louis D. Brandeis of Boston as attorney for the Interstate Commerce Commission in the pending eastern rate advance case is not the least significant development in connection with this most recent demand of the eastern lines that they be allowed to earn more revenue. When the railways of both the East and West sought three years ago to advance their rates they encountered determined and organized opposition from the shippers. No similar opposition has been offered to the present movement of the eastern lines for a general advance of 5 per cent. It had begun to look as if there would be practically no opposition. Nobody has been authorized, apparently, to state what is the commission's motive in appointing Mr. Brandeis. It seems quite probable, however, that the commission felt that in spite of the lack of concerted opposition on the part of the shippers, a general advance in rates should not be authorized without a real investigation of its merits, and that it appointed Mr. Brandeis to the role of an inquisitor of the witnesses for the railways to make sure that all the pertinent facts would be brought out. If this surmise be correct, neither the commission's action in appointing an attorney, nor its selec-

tion of Mr. Brandeis, can justly be criticized. All of the pertinent facts, whether adverse or favorable to the railways, ought to be laid before the commission before it reaches its decision, and no better-equipped man to bring out those adverse to the railways could have been chosen than Mr. Brandeis. Past experience indicates that Mr. Brandeis may resort to the methods of sensationalism and the muckraker as well as to those of the lawyer. But railway counsel and managers must recognize that if they are effectively to defend the properties they represent they must be prepared to meet attacks on them of all kinds and with all manner of weapons. If the case of all the railways, or any of them, is vulnerable, that is the fault of their managements; and if it is not vulnerable they can defend it against one kind of attack as well as another if they are fit for their jobs.

#### THE AGITATION FOR GOVERNMENT OWNERSHIP OF RAILWAYS.

FOR some months *Pearson's Magazine*, whose chief boast is that it publishes articles no other magazine will print, has been running a series by Charles Edward Russell, advocating government ownership of the railways of the United States. In its October issue *Hearst's Magazine* begins a series by Alfred Henry Lewis, also advocating government ownership of railways. Mr. Lewis has not heretofore been known as an expert on railway matters. His most recent claim to distinction is that he acted as publicity agent for Harry Thaw in his campaign for release from the Matteawan insane asylum; and he writes according to the accepted muckraking formula, which consists of nine parts slab-dash and one part glitter. "The railroads (of the United States) by light of last year's figures are," he says, "killing 712 and wounding 15,996 people a year." These figures are very much smaller than the correct figures for the total fatalities and injuries in the fiscal year 1912, and are not the correct figures for any particular class or classes of railway accidents. Continuing, Mr. Lewis contrasts the accident statistics of the railways of the United States with those of the railways of France. It is true that the French railways are remarkably safe, but no advocate of government ownership who knew anything about his subject would mention their accident statistics. The excellent record of the French railways as a whole is due entirely to the exceptional safety of the private railways; for the State railways of France are the most unsafe lines in any leading country in the world. The French private railways have a mileage of 19,610 miles; the French State railways have a mileage of only 5,546 miles. Nevertheless, in the year ended June 30, 1910, while the private railways killed only 5 passengers in train accidents, the State railways killed 66. For every 10,000,000,000 passengers carried one mile the private railways killed 6, while for every 10,000,000,000 passengers carried one mile the State railways killed 315, or 53 times as many. Obviously, the accident record of the French railways is an argument against, not for, state ownership! For every 10,000,000,000 passengers carried one mile the railways of the United States in the year ended June 30, 1911, killed only 107 in train accidents, so that their record in this respect was only one-third as bad as that of the French State railways.

In another place Mr. Lewis, after having mentioned the land grants made to the railways of the United States, says, "Not a railroad of them all ever offered one of those acres for less than \$2.50." Now, the truth is that a large part of the land given to the railways was not only offered, but sold by them, for less than \$2.50 an acre. For example, the land donated to the Union Pacific in what is now the state of Wyoming included a 400-foot strip through the state for 445 miles, or approximately 22,196 acres, and 5,000,000 acres elsewhere. The government price for land in Wyoming at that time was \$1.25, but the Union Pacific sold over 70 per cent. of its grant in Wyoming for from 44 cents to \$1.25 per acre. It underbid the government in selling land because it

was anxious to develop the country along its line and thereby increase its traffic.

The accuracy of the rest of Mr. Lewis' statements may be judged from that of those mentioned. The bulk of his article is devoted to showing how Collis P. Huntington is alleged to have purchased public men, and especially members of Congress, in order to make and keep them friendly to his railway projects. The data given relate to occurrences prior to 1880, or more than 30 years ago. What railway men were doing then no more indicates what they are doing now than what public men were doing then indicates what they are doing now. Therefore, if Mr. Lewis' evidence in regard to what Mr. Huntington was doing over 30 years ago shows, as he says, the character and methods of the present generation of railway managers, it also shows the character and methods of the public men and members of Congress of the present generation. In other words, if it shows that the railway managements of today are bribers of public men, it also shows that the public men of today are bribe-takers, and that those who advocate government ownership are advocating turning the management of the railways over to public men who are corruptionists and blackmailers. Just how it can be assumed that this would improve matters, does not appear entirely clear.

While it is easy for any one familiar with railway affairs to tear to shreds the articles of such men as Russell and Lewis, it does not follow that their writings can safely be ignored. The people whom they reach know little about railway matters and are not aware of how ignorant or dishonest Lewis and Russell are. Therefore, many persons are bound to be misled by them. What is worse, Lewis and Russell are far from being the only people who are producing literature of this character. Every day hundreds of thousands, and even millions, of pieces of literature attacking, not merely private ownership of railways, but private property of all kinds, are being distributed throughout the United States. Some of this originates with persons who are avowed socialists. Much of it originates with persons who are socialists without knowing it. The purpose of it all is to revolutionize the industrial and economic system and the form of government of this country. The railways are properly regarded by Mr. Russell and similar propagandists as merely the first outpost which must be taken in the campaign for the establishment of a socialistic state. Once government ownership of railways was adopted they would begin with redoubled energy to fight for the socialization of all means of production, distribution and exchange. Bismarck thought that by nationalizing the railways of Germany and adopting various other socialistic measures he could check the rising tide of socialism. The results have shown he was mistaken. The Socialist party in Germany has continued to grow, and under manhood suffrage it might soon triumph.

It is not merely property in railways that is under attack in the United States. It is the right of private property in anything. It is but a few years since the single tax doctrine was an object of ridicule. Today it has many thousands of supporters. In other words, the attack on private property in land as well as the attack on private property in railways is making progress. While many are attacking private property, few are defending it. The reason is that few are awake to the situation that is developing. While the stupid poor are being misled by people like Russell and Lewis, the stupid rich are doing many things that bring private property into disrepute and almost nothing to defend it. If the manufacturers, the bankers, the mine operators and the farmers of the United States realized whither we are drifting they would be co-operating with the railways in carrying on a campaign for fair regulation of railways and against government ownership of railways. But throughout history the stupidity of the "have nots" has been equalled only by the stupidity of the "haves." And so this flood of socialistic literature which is being poured forth continues to be largely unanswered.

## ADJUNCTIVE SAFEGUARDS.

It is to be admitted that "adjunctive" is not a pleasant sounding word; but it is entitled to a good reputation, for in the Standard Code "adjuncts" occupy a prominent place. In the rules for manual block signaling, so important a feature as the distant signal is put down as an adjunct, which *may* be used. In automatic block signaling track circuits are likewise classed as optional! In interlocking, these and a dozen other things are made optional, and classed as adjuncts. There are, however, two important adjuncts, of another class, concerning which the Standard Code is not so explicit; (a) the fireman's lookout for fixed signals, as an adjunct to the engineman's lookout, and (b) the flagman's function as a preventer of rear collisions, in which function his office is that of an adjunct to the block signal system. These adjuncts are just now the subjects of much discussion. Both of them proved useless on the New Haven road September 2, when 21 passengers were killed.

The weakness of the rule which requires enginemen and firemen to call the signals to each other as they approach the signal location was here well illustrated. The rule is weak, at best, for there is no satisfactory way of checking the men's obedience to it, and it is hard to hold either man to the duty of calling first; but in running through fog the likelihood of disobedience probably is stronger than in clear weather, for a fireman can very naturally assume that in fog the engineman is forced to be particularly alert every moment; is least likely to miss anything and least in need of a monitor. And, the view being short, the fireman has not so good a chance to see signals at the right hand side of the track. At North Haven the grade was easy and the fireman's work was not specially hard, and yet he did not detect, or at all events did not check, the excessive speed. It is clear that if the fireman's monitorship is to be a satisfactory safeguard on fast trains he must not only see signals after the engineman sees them, but must also be on the lookout for them independently. If a signal is visible for only a few hundred feet there are but a few seconds in which to see it. This collision again emphasizes the lesson, which has been made plain enough on many former occasions, that this monitorship rule should be made stronger (if that is practicable) or else that some other safety measure should be adopted in the place of it. Every failure of this kind serves to push the railroad world farther along toward the position where a majority will declare that automatic train stops are our only hope.

At North Haven the flagman also failed. It would be easy to formulate an argument that the flagman's failure was the worst feature of the case; that to cure his fault is the first duty of the day. Mr. Belnap places this first in his statement of causes. Many branch lines and other lines of thin traffic are still without block signals, and on these flagging is a vital feature. Because of this, and of lifelong habits of mind, enginemen and other trainmen everywhere think of flagging as the most critical feature of the code of rules, and officers are all the time working to impress this view. Because of the difficulty of enforcing the flagging rule it has received more than its proportion of attention.

But, notwithstanding these circumstances, flagging is, on block signaled lines, an adjunct. The block signals are the main thing. In the early days of block signaling, there was a general attempt to maintain the time interval as the chief protection and to treat the block signal as secondary, but everybody was forced to abandon that notion, for the logic of everyday experience constantly showed its absurdity.

And now flagging is secondary. Block signals are not perfect (and it may be admitted that they could not be made absolutely perfect by adding automatic train stops) and so the spectacle of the officer urging the flagman to do his duty is as familiar today as it was when block signals were unknown. But the perplexities are as great as ever. What can be done?

In an article in another column the difficulties connected with flagging are recounted somewhat at length; not with the idea

that these difficulties are not already known, but because they have never been adequately formulated. This is a great lack. This article does not attempt to meet this lack, but it is hoped that it will serve to point out some of the facts which indicate the need of meeting it. A really satisfactory treatment of the subject would mean a task for a strong committee of the American Association of Railroad Superintendents.

The crucial difficulty with flagging is that the rule constantly calls for delicate judgments on the part of men whose selection, training and pay are not of a kind to furnish the mental and moral character necessary to form delicate judgments on the spur of the moment. The surgeon, who must decide quickly one or more questions on which may hinge a man's life, has had several years' systematic and constant training; we require the flagman to decide questions which potentially are of equal importance, or even greater, when he has had only unsystematic and fragmentary training. The great inconsistency of this feature of railroad operation is that this delicacy of the flagman's function is admitted, while yet we do not take thorough measures to fit him for his work. The fault of the flagman and the engineman, in depending each too much on the other, is repeated in the superintendent's office. Assume that the desideratum is a factor of safety of two. The block system, without the flagman, is, let us say, 99 per cent. perfect (it is, undoubtedly, much more than that); the flagman even in his present inefficiency, takes adequate measures to protect his train, let us say, in 99 per cent. of cases. These two protective measures overlapping, we imagine we have 198 per cent. of safety; so nearly a factor of two that we let it go at that. This little computation is only a mathematical false-work; but does it not truly illustrate the character of some of our thinking? The point which seems to be forgotten is that not 198 per cent., nor even 199.99 is satisfactory.

Nor can we say that the public, educated, as the public is, by the sensational and superficial daily press, is wholly unreasonable. It demands all sorts of impossible things, and the railroad director has, indeed, a task to try to lead people and legislators to take reasonable views; but the operating officer, grappling at short range with this problem, is bound to aim at 200 regardless of the public. He desires the same himself. The only difference that should exist between him and the ignorant or hysterical spokesmen of the public is that the measures taken by him must be always rational and progressive. And it will be admitted that the present flagging practice cannot be classed as either rational or progressive.

## MISSOURI PACIFIC.

A COMPARISON of the income accounts of the Missouri Pacific system for 1911, 1912 and 1913 borders on the romance of railroading. Total operating revenues in 1911 were \$52,777,000; in 1912, \$54,503,000, an increase of 3.27 per cent.; and in 1913, \$62,156,000, a further increase of 14.04 per cent. over 1912. Operating expenses in 1911 were \$43,330,000; in 1912, \$41,281,000, a decrease of 4.73 per cent.; and in 1913, \$44,700,000 an increase of 8.28 per cent., of which \$3,418,000 increase in 1913, \$2,127,000 was in maintenance. The net corporate loss in 1911 was \$5,233,000; in 1912, \$1,979,000, and had been turned into a net corporate *income* of \$1,563,000 in 1913.

Freight traffic density in 1911 was 607,000 tons; in 1912, 663,000 tons, an increase of 9.21 per cent.; and in 1913, 781,000 tons, an increase of 17.80 per cent. over 1912. President Bush refers to this fact in pointing out the necessity of further additions and betterments, for which the company must pay by the issue of capital securities; and interesting and convincing as it is in this connection, it is also a remarkable commentary on the gain that has already been made in the effective operation of the present plant. The average mileage operated in 1911 in the Missouri Pacific system, which includes the St. Louis, Iron Mountain & Southern, was 7,235 miles, and in 1913 was slightly greater—7,257 miles. The company divides this mileage as between branch line

and main line mileage, classifying about 4,700 miles as main line and about 2,300 miles as branch line. Of the total mileage in 1911, 31.48 per cent. was entirely unballasted and 29.40 per cent. was ballasted with gravel. Of the total in 1911, 34.19 per cent. was laid with 56-lb. rail, and but 30.67 per cent. with 85-lb. rail. In 1913 30.23 per cent. of all tracks was unballasted and 25.38 per cent. was ballasted with gravel, the change from gravel being to either cinders and slag or chatts. In 1913 31.55 per cent. of all tracks was laid with 56-lb. rail or lighter, and 33.67 per cent. with 85-lb. rail. During the past two years the company has spent \$8,326,000 for additions and betterments, and it can easily be seen what tremendous expenditures will still have to be made to bring the property up to the standard of such a road as the Union Pacific. The point is, however, that in these two years the management has been successfully engaged in demonstrating that the property was worth spending money on for additions and betterments.

If it is possible under the proper management to change a net loss, after the payment of interest charges, of over \$5,000,000 into a surplus of more than \$1,500,000, after paying the interest

best. In St. Louis especially, and to a nearly equal extent in Kansas City, the M. P. has facilities for getting the very cream of the freight business. Of the total tonnage, amounting to 23,310,000 tons, carried in 1913, 36.2 per cent. was products of mines, 21.9 per cent. products of forests, 17.3 per cent. products of agriculture, 13.5 per cent. manufactures, 5.1 per cent. merchandise, and 4.2 per cent. livestock and animal products. The increase in tonnage, which amounted to 3,171,000, or 15.7 per cent., was greatest in agriculture and in lumber and forest products, but was general in all classes of commodities, the increase in products of agriculture amounting to 22.7 per cent.; products of forests, 20 per cent.; products of mines, 18.8 per cent.; manufactures, 8.8 per cent.; and in livestock and animal products, 8.1 per cent.

The revenue train load in 1911 was 291 tons; in 1912, 333 tons; and in 1913, 373 tons. Carloading in 1911 per loaded car was 16.22 tons; in 1912, 16.90 tons; and in 1913, 18.06 tons. While passengers carried one mile increased 8.42 per cent. in 1913 and totaled 502,100,000, and revenue freight ton miles increased 18.23 per cent. and totaled 5,668,400,000, passenger train miles in-

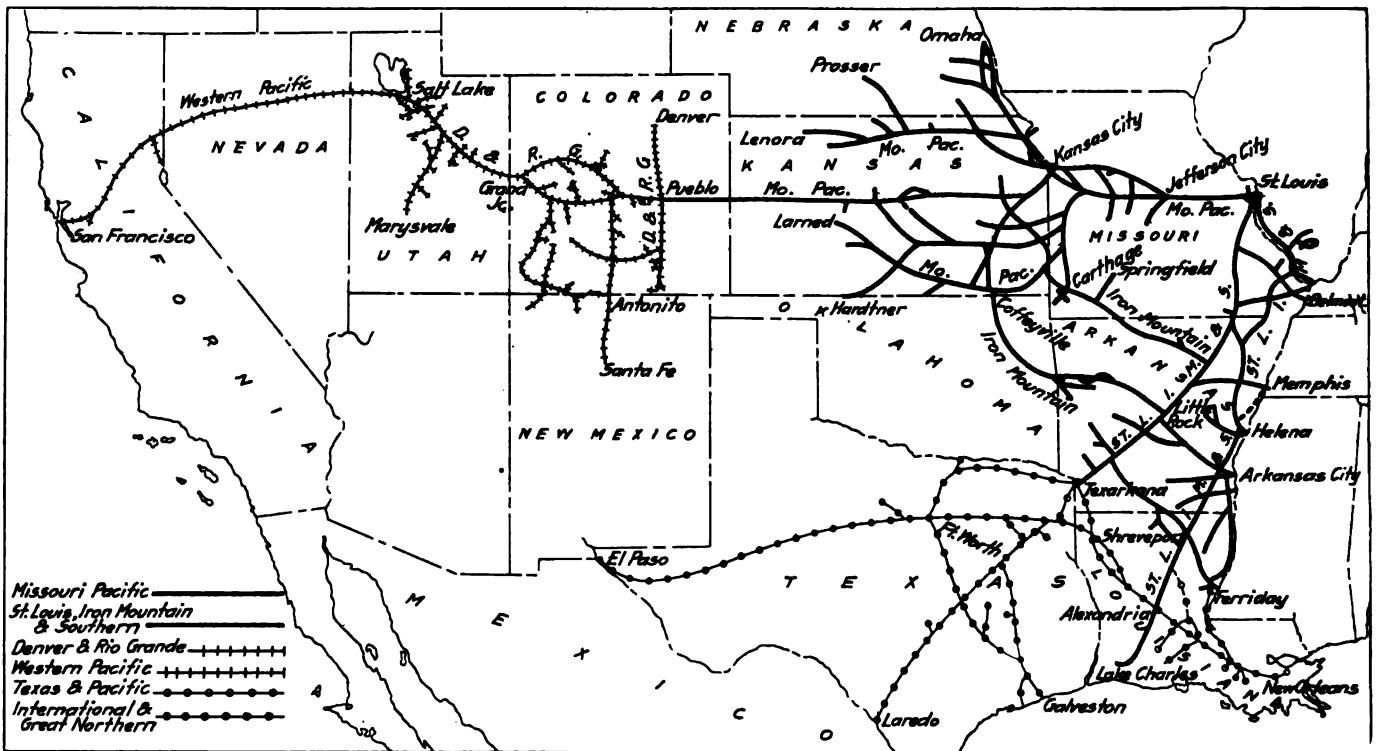

The Missouri Pacific and Its Gould Connections.

on the \$8,000,000 spent for betterments, although not conclusive proof in itself that further very heavy expenditures will be justified, it is strong evidence to this effect. While, of course, the best friends of the Missouri Pacific would acknowledge that its operating efficiency at the time the present management took hold of it was low, the gain that has been made since is probably better than even the most optimistic of these friends would have hoped for.

The amount of gross business that may be secured by the Missouri Pacific depends to a larger extent than on almost any other road in the country, on the ability of the company to expeditiously handle the traffic. The Missouri Pacific system has a north and south line in the Mississippi valley corresponding on the right shore south of Cairo, Ill., with the Illinois Central on the left shore, and has as feeders from the southwest the International & Great Northern and the Texas & Pacific. It has in its main line from St. Louis via Kansas City to Pueblo, Col., an effective instrument for competition with the Union Pacific on transcontinental business, and the facilities in St. Louis, Kansas City, Omaha, St. Joseph, Memphis, etc., are of the

increased but 6.13 per cent., totaling 12,547,000, and freight train miles increased but 5.78 per cent., totaling 14,197,000 miles.

The following table shows the ratio of each class of expenses to total operating revenues:

	1913.	1912.
Maintenance of way and structures.....	14.90	15.90
Maintenance of equipment.....	15.86	15.27
Traffic expenses.....	2.29	2.49
Transportation expenses.....	36.25	39.02
General expenses.....	2.61	3.06
Total.....	71.91	75.74

There is no general combined balance sheet for both the Missouri Pacific and the St. Louis, Iron Mountain & Southern given in the annual report; but it is evident that one or both of the companies will in the not distant future have to come in the market for additional capital. Cash in the Missouri Pacific treasury amounted to \$503,000 at the end of 1913, as compared with \$1,478,000 at the beginning of the year; and to \$641,000 in the treasury of the St. Louis, Iron Mountain & Southern at the end of the year, as compared with \$826,000 at the beginning of the year. It is proper to point out, however, that at the end

of the year there was no floating indebtedness, except, of course, current vouchers, etc., outstanding for either company.

The following table shows the principal figures for operation in 1913 as compared with 1912:

	1913.	1912.
Average mileage operated.....	7,257	7,231
Freight revenue .....	\$45,748,269	\$39,514,356
Passenger revenue .....	11,627,481	10,662,443
Total operating revenues.....	62,155,506	54,503,250

**CHICAGO, ROCK ISLAND & PACIFIC.**

THE operating management of the Chicago, Rock Island & Pacific labor under a difficulty peculiar to this company alone of all the roads in the United States and one for which they are of course in no way responsible. The C. R. I. & P. Railway (the owning and operating company) is not very heavily capitalized; but not only is its mortgage debt more than

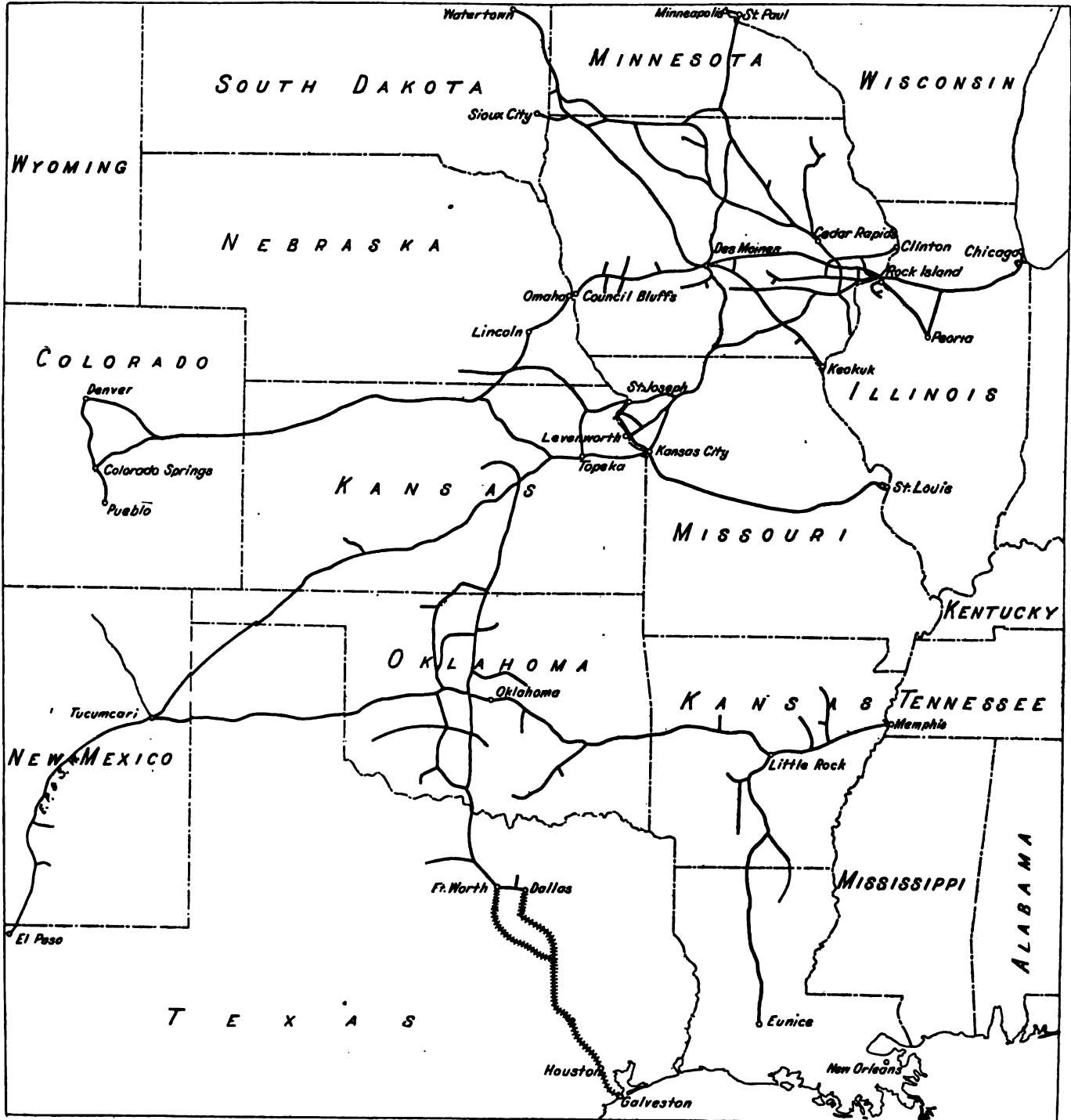

**The Chicago, Rock Island & Pacific.**

Maint. of way and structures.....	9,263,360	8,664,769
Maint. of equipment.....	9,860,188	8,321,787
Traffic expenses .....	1,425,168	1,358,014
Transportation expenses.....	22,528,447	21,268,314
General expenses.....	1,621,834	1,667,708
Total operating expenses.....	44,698,997	41,280,592
Taxes .....	2,314,349	2,218,018
Operating income .....	15,049,156	10,883,787
Gross income .....	17,512,755	13,130,432
Net income .....	1,562,734	1,979,091*

\*Deficit.

twice its outstanding stock, but the dividend requirements of 5 per cent. on the outstanding \$75,000,000 stock amount almost, if not quite, to a fixed\* charge.

\*The Chicago, Rock Island & Pacific Railway Company stock is deposited as collateral under Chicago, Rock Island & Pacific Railroad bonds, and 5 per cent. on the Railway stock amounts to but little more than the interest charges on the Railroad bonds. Control by the Rock Island Company of the C. R. I. & P. is dependent upon the payment of interest charges on the Railroad bonds without default.

This leaves the management where it can adjust outgo to come only by varying maintenance charges to meet falling off in earnings. Conversely, when the earnings increase, prudence compels heavy increases in maintenance charges.

This latter was the case in the fiscal year ended June 30, 1913. Total operating revenues amounted to \$71,365,000, an increase over 1912 of \$6,652,000, or more than 10 per cent.; and operating expenses were \$52,504,000 in 1913, an increase of \$5,745,000, or 12 per cent., of which increase, however, \$3,162,000 was in maintenance charges and but \$2,562,000 in transportation expenses. The handicap which is placed on the operating management by such an indefensible financial arrangement as that of the Rock Island's makes an economical operation of the property peculiarly difficult, and gains in operating efficiency are, therefore, all the more creditable.

In 1913 the Chicago, Rock Island & Pacific carried 21,102,000 tons of revenue freight, an increase over 1912 of 11.24 per cent., with 16,762,000 freight train miles, an increase over 1912 of 5.90 per cent.; and carried 19,413,000 passengers, or 2.57 per cent. more than in 1912, with 18,775,000 passenger train miles, an increase of 2.26 per cent. The average haul of freight in 1913 was 247 miles, or 4.15 per cent. longer than in 1912, and the average passenger journey was about 50 miles, or only slightly more than in 1912. The average revenue train load of freight was 297 tons in 1913 and 278 tons in 1912. This is a gain in train loading of nearly 7 per cent. in the one year, while the total gain in train loading in the last five years has been only about 12 per cent.

The Rock Island's train load is not very heavy when we consider that more than 30 per cent. of its total tonnage is furnished by products of mines. On the other hand, 27 per cent. last year of its total tonnage was furnished by grain and other products of agriculture, which, of course, do not permit of very heavy loading, and necessitate a large empty car mileage which acts to bring down the average train load. The larger train load in 1913 was the result both of better car loading—15.79 tons per loaded car in 1913 and 15.11 tons in 1912—and the elimination of some empty car mileage—the number of empty cars per train in 1913 being 7.07, and in 1912, 7.25.

In addition to the handicap of the rigidity of dividend requirements, there is the great physical difficulty of operating such a system as the Rock Island. It is sprawled out over 14 states. There are all sorts of conditions; lines from Chicago to Minneapolis and to Kansas City have to meet very severe competition, while the branch lines in Oklahoma, Arkansas and Louisiana have hard work to get traffic enough to support them; and to add to the difficulties of operation, a good many of the branch lines, while in as good physical condition as present traffic justifies, are laid with light rails and have little or no ballast. It is not surprising, therefore, that the average train load is small, and even a small increase in the average reflects probably the result of a great deal of effort and time on the part of the management. On a system where conditions are so diversified as on the Rock Island, if the general superintendent of one district succeeds in getting more effective work out of his organization and a resulting better train load, it is likely that the general superintendent of one of the other districts will have some adverse conditions which are beyond his control which will lower his train load and thus offset in the total average the gain in efficiency made on the other district.

The contention that increases in business will offset higher wages, higher cost of fuel and other material is not borne out by a comparison of the Rock Island figures for 1909 and 1913. If we take the average train load in 1909 of freight and the average number of passenger per train, and work out an equivalent for total ton mileage so as to get a basis of comparison of work done, we find that total transportation expenses in 1909 per unit\*

\*In 1909 the average train load was 265 tons and the average number of passengers per train mile 58. A passenger mile is, therefore, taken as the equivalent of 4.6 ton miles, and this ratio is used to translate passenger miles into ton miles in 1913.

were 2.7 mills as against 3 mills in 1913. This is an increase in transportation costs per unit of work done of 11 per cent, despite an increase in revenue train load of 12 per cent. The unit used would reflect a saving either in freight train loading or in increased passengers per train mile. There was, however, a decrease in the number of passengers per train mile of 8 per cent. In 1909 transportation expenses per train mile of total train miles was 68.8 cents, and in 1913, 76.7 cents, an increase of more than 11 per cent.

The following table shows the ratio of each class of expenses total operating revenues for the years 1913 and 1912, and emphasizes the point previously mentioned that the increase in expenses this year is largely due to the fact that the company had more money to spend on maintenance, and spent it.

	1913.	1912.
Maintenance of way.....	13.85	13.13
Maintenance of equipment.....	14.11	12.83
Traffic expenses.....	2.80	3.06
Transportation expenses.....	40.32	40.50
General expenses.....	2.49	2.74
Total.....	73.57	72.26

When the Chicago, Rock Island & Pacific sold its \$20,000,000 debentures in January, 1912, the company agreed to sell no more first and refunding bonds until January 1, 1914. During the past year \$9,538,000 was spent for additions and betterments and for additional equipment. There was issued \$3,480,000 net bonds, which are held in the company's treasury, and \$3,146,000 net equipment trust notes, which were sold, making a total increase of securities in the hands of the public of \$3,146,000 and \$4,476,000 securities issued held in the treasury. At the beginning of the year the company had \$15,074,000 cash, and drew on this to pay for additions and betterments, leaving at the end of the year \$5,120,000; but had \$6,667,000 audited vouchers and wages unpaid, as compared with \$3,704,000 unpaid at the end of 1913. It is understood that since the close of the year the amount of outstanding audited vouchers, etc., has been materially reduced; but since the company has issued no new securities and cannot issue any until the first of January, 1914, it has presumably had to draw on surplus earnings and cash to liquidate these accounts.

The following table shows the principle figures for operation in 1913 as compared with 1912:

	1913.	1912.
Average mileage operated.....	8,048	8,036
Freight revenue.....	\$46,428,045	\$41,156,835
Passenger revenue.....	19,777,431	18,609,408
Total operating revenues.....	71,364,935	64,712,853
Maint. of way and structures....	9,885,324	8,493,346
Maint. of equipment.....	10,072,854	8,302,467
Traffic expenses.....	1,999,138	1,981,399
Transportation expenses.....	28,772,587	26,210,502
General expenses.....	1,774,199	1,771,780
Total operating expenses.....	52,504,102	46,759,494
Taxes.....	2,946,438	2,793,315
Operating income.....	15,914,395	15,160,044
Total income.....	16,944,190	15,887,289
Net income.....	4,058,355	3,850,396
Dividends.....	3,743,525	3,743,760
Surplus.....	314,830	106,636

#### SOUTHERN RAILWAY.

THE Southern Railway's annual report for the fiscal year ended June 30, 1913, is full of Mr. Finley's belief in the South, his pride in what the country is doing and his appreciation of what the officers of the Southern Railway are doing to aid in this development. While it is true that the great development of the southeastern states in the last five or six years is in considerable part a monument to Mr. Finley and the Southern Railway, railroad men and investors will find in a study of what has been accomplished on the Southern Railway itself a record of achievement that is intensely interesting.

The table at the end of these remarks shows in some detail the results of operation in 1913 as compared with 1912, from which table it will be seen that after paying the full 5 per cent. interest on the preferred stock in 1913 as against 4½ per cent. in 1912, and despite spending 18 per cent. more for maintenance of way and 12 per cent. more for maintenance of equipment, the

company had a surplus of \$4,079,000. This, however, tells only part even of the financial history of the company for the year. During this year the Southern paid off out of treasury funds \$5,000,000 notes and spent \$3,517,000 for additions and betterments, the only capital securities sold being \$1,500,000 first consolidated mortgage 5 per cent. bonds.

The operating "story" is suggested by an increase in ton miles of 8.81 per cent. (the total ton mileage in 1913 being 4,577,500,000) and in passenger miles of 7.40 per cent. (the total number of passengers carried one mile in 1913 being 844,800,000), with an increase of but 6.90 per cent., or \$1,523,000, in transportation expenses, which includes about \$574,000 increases in wages.

Of course, what the Southern Railway has needed, ever since the consolidation of its network of lines, has been increased traffic. In 1908 gross revenue per mile was \$7,187; in 1913 the Southern earned gross \$9,903 per mile. The history of the building up of this traffic has been told before in the *Railway Age*

end of 1909, and also of all discount on securities sold since then.

Maintenance of a railroad property, and its service to the public, its ratio of transportation expenses to total operating revenues, and its credit, are all inseparably interrelated and all are dependent to a large extent on the betterment of the plant. Under a less able management and, of course, also under less favorable development of the country, which again is due in no small measure to the efforts of the Southern Railway management, it would have been impossible for that company to have lifted itself out of the hole that it was in in 1907 by its own boot straps; but that is just what has been accomplished. Money earned has been put into additions and betterments; dividends were deferred until the more pressing needs of the property were met; maintenance expenditures were increased as rapidly as earnings justified; and the net result of it all is beginning to be shown in the decrease in transportation expenses per unit of work done and

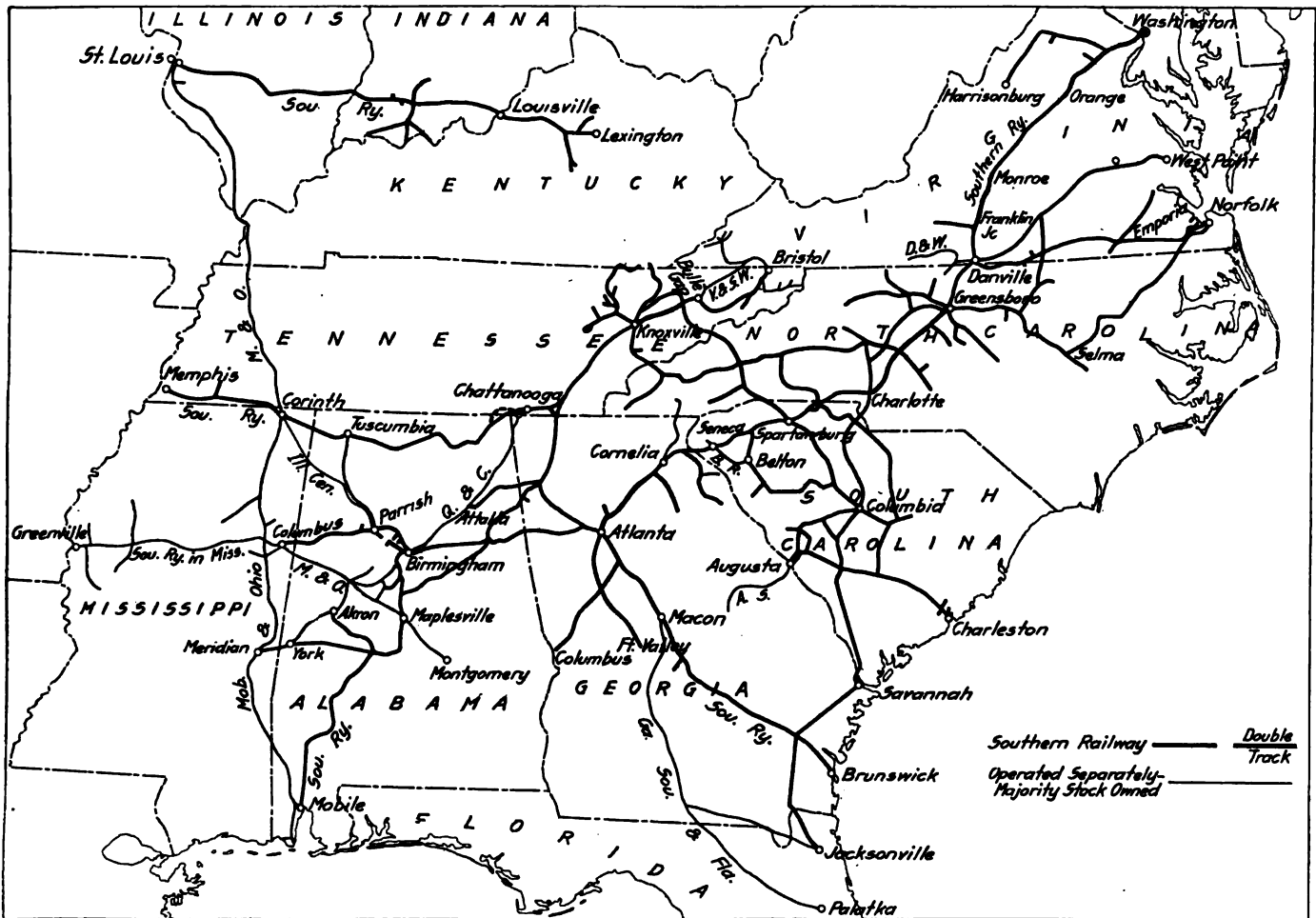

The Southern Railway.

*Gazette*, and is told from time to time in Mr. Finley's addresses better than we can possibly tell it; but the full measure of the achievement in conserving to the company its legitimate share in the growing prosperity is more likely to be lost sight of because at first glance it is less striking.

The keynote of this development has been intensive conservatism. In 1908, when operating income, after the payment of expenses and taxes, was \$11,080,000, interest on funded debt, equipment trust certificates and rentals was about \$11,800,000, while in 1913, with operating income of \$17,856,000, interest and rentals were but \$12,595,000. During these years the company has paid out total preferred dividends of \$6,900,000, while it has increased its profit and loss surplus from \$5,791,000 to \$17,375,000, and at the same time completely gotten rid of \$1,991,000 discount on securities sold, which it was carrying at the

in the substantial surplus of \$4,079,000 after the full 5 per cent. on the preferred.

The following table shows the ratio of each class of expenses to total operating revenues:

	1913.	1912.
Maintenance of way and structures.....	13.54	12.33
Maintenance of equipment.....	16.48	15.90
Traffic expenses.....	3.06	2.74
Transportation expenses.....	34.45	34.72
Total.....	70.44	68.71

Maintenance of way in 1913 amounted to \$1,318 per mile of road maintained; and repairs of locomotives, exclusive of renewals and depreciation, to \$2,615; repairs of passenger train cars, \$735; and repairs of freight train cars, \$66.

The Southern Railway operates 7,036 miles of road and had a freight density in 1913 of 804,000 tons, an increase over 1912 of 9.57 per cent.; and a passenger density of 120,070. The aver-



age freight train load of revenue freight in 1913 was 260 tons, as against 250 tons in 1912; and the average number of passengers per train, 46 in 1913 and 44 in 1912; the average haul of freight being 155 miles in both 1913 and 1912, and the average passenger journey, 44 miles in 1913 and 43 miles in 1912.

Of the total tonnage carried, amounting in 1913 to 29,450,000 tons, 40 per cent. was products of mines, 30.03 per cent. manufactures and miscellaneous, 16.98 per cent. products of forests, 11.89 per cent. products of agriculture, and a little over 1 per cent. products of animals.

The following table shows the principal figures for operation in 1913 as compared with 1912:

	1913.	1912.
Average mileage operated.....	7,036	7,088
Freight revenue .....	\$44,943,748	\$41,508,300
Passenger revenue.....	18,220,489	16,939,811
Total operating revenues.....	68,529,490	63,590,329
Maint. of way and structures..	9,275,553	7,841,220
Maint. of equipment.....	11,290,337	10,108,673
Traffic .....	2,094,010	1,745,353
Transportation .....	23,605,046	22,081,653
General expenses.....	2,008,977	1,919,337
Total operating expenses.....	48,273,924	43,696,236
Taxes .....	2,480,387	2,452,328
Operating income.....	17,855,715	17,506,519
Gross income.....	21,221,686	21,086,961
Net income.....	7,078,625	6,763,117
Dividends .....	3,000,000	2,700,000
Surplus .....	4,078,625	4,063,117

### NEW BOOKS.

*Proceedings of the Society for the Promotion of Engineering Education.* Part 2, Volume 20. Size, 6 in. x 9 in., cloth binding, 508 pages, illustrated. Price \$1.25. Published by the society, H. H. Norris, secretary, Ithaca, N. Y.

This volume contains that portion of the proceedings of the twentieth annual meeting held in Boston, June 26-29, 1912, relating to the work of engineering laboratories in all divisions of engineering and includes 55 papers and discussions. Among the papers of special interest are a discussion of "The Characteristics of the Mechanical Engineering Laboratories of American Engineering Colleges," by Prof. Wm. T. Magruder, a detailed description of Charlottenburg laboratories by R. R. Heuter; a description of the new Robinson laboratory at the Ohio State University by Prof. Horace Judd, and a paper on the teaching of elementary physics by Profs. W. S. Franklin and B. MacNutt.

*Factory Lighting.* By Clarence E. Clewell. Bound in cloth. 156 pages. 6 in. x 9 in. Illustrated. Published by McGraw-Hill Book Company, 239 West 39th street, New York. Price \$2.

Examples can be seen on every side that a large amount of artificial lighting does not necessarily mean good lighting. Violations of the principles of good illumination have been frequent in otherwise perfectly appointed shop buildings and offices. There is no doubt that good lighting is an aid to accurate workmanship and manufacturing output, and contributes to a large extent to a reduction in manufacturing cost. The author of this book has been engaged in the design and supervision of the installation of lighting systems for a number of years, and aims to tell how to obtain good lighting and to tell it in a simple way. The experiences of actual installations are made the basis for analysis and explanation throughout the book. Actual results are given precedence over generalized statements. The office, the drafting room and the power house have been given consideration as well as the shop itself. One chapter is devoted entirely to machine tool lighting and the insignificance of the cost of adequate lighting for machine tools is illustrated by the statement that the energy and maintenance of an individual electric lamp amounts to 25 cents a month, while the operator who depends on the lamp receives \$3 a day. Therefore, the cost of the lamp is equal to the wages for two minutes each day, and if the better illumination will save the workman that amount of time it is a paying investment. Photographs are freely used to emphasize the facts explained in the type and drawings of typical installations are included.

## Letters to the Editor.

### THE SANTA FE LOSS AND DAMAGE COMMITTEE.

ST. JOSEPH, Mo., October 9, 1913.

TO THE EDITOR OF THE RAILWAY AGE GAZETTE:

Throughout the week of September 29 the transportation, traffic and claim officials of the Santa Fe railroad, to the number of 100, held in St. Joseph a semi-annual meeting of the Santa Fe System Loss and Damage Committee. On one day of this meeting the members of the committee were guests of the Commerce Club of St. Joseph at luncheon when the nature and scope of the work of the committee was explained to the club members, who, in most part, were shippers of freight.

Information was given as to the magnitude of the item of loss and damage, what effort is being made to prevent such waste or reduce to a minimum and how this undertaking could be advanced by better packing, better marking and better handling. The lucid presentation of the subject attracted keen attention and elicited assurance from shippers present of a willingness to co-operate in securing the desired result.

This coming together and the free interchange of experiences and views on a subject of such great importance should not fail of producing excellent and lasting results. In conference of this kind opportunity is afforded for working out in a practical way the "get-together" spirit, between carriers and shippers, concerning which so much has been said in the past few years. The example set by the Santa Fe in this instance, by taking the public into its confidence, is one which might with profit be followed by other railroads, and in other branches of their work for the betterment of service to be rendered the public.

Though it may not thus always appear, it is nevertheless, I believe, a fact that the shipping and traveling public as a whole wishes to be reasonable and fair in dealing with the railroads, and will treat with them in that spirit when enlightened on the problems and difficulties with which they (the railroads) have to contend, and come to appreciate that the railroads are honestly striving to fully meet their public obligations. True it is that for some time the railroads have in a general way been trying to impress on the public mind the efforts they are making for improved service and added safety—and have made progress in that direction, but the closer personal touch, as in the case cited, is of more immediate and telling effect, and secures more ready response than it is possible to develop by other means. In the advancement of a closer community of interest between the railroads and the public let us hope that the policy of the Santa Fe Loss and Damage Committee may be enlarged and extended.

H. G. KRAKE,

Commissioner, Commerce Club of St. Joseph:

**PASSENGER TRAFFIC AND FESTIVALS IN INDIA.**—The great festival of Ruth Jahr, at Puri, has proved so paying to the Bengal-Nagpur Railway that it spares no pains or money towards the convenience and comfort of pilgrims, even at the junctions with foreign lines. The reports of the committee appointed by this railway to inquire into the arrangements connected with festivals make interesting reading. They show that the officers go into the genesis of each festival and make the arrangements according to the needs of the various classes of pilgrims. Very soon a lunar eclipse will be visible in India. The occurrence of a lunar eclipse on a Monday and under certain conditions is looked upon as a rare occasion for rites and ablutions among Hindus. This Chudamani Yoga will move many thousands of pilgrims to bathe in the holy waters of the Ganges, the Nerbudda, the Canvey, the Jumna, the Godavery, and the Indus. Though this lunar eclipse will benefit all the railways leading to many holy spots, it will be a strain on the Bengal-Nagpur Railway, which serves more than one center of attraction; but the road seems to be equal to these occasions.

# THE FLAGGING RULE AND ITS ENFORCEMENT.

## The Complexity of the Every-Day Problems Which Face the Flagman on the Road and the Trainmaster in the Office.

The prominence given to the question of flagging in two recent reports on collisions—Tyrone, Pa., July 30, and North Haven, Conn., September 2—has led to a good deal of fresh discussion of this very old subject; and in view of the great variety that obtains in flagging practice, under different conditions, it will be timely to restate some of the conditions under which this very troublesome regulation has to be carried out. Everybody admits that we have here a complicated problem, but only rarely does any one analyze it with the thoroughness which its importance demands.

The flagging rule of the American Railway Association is as follows:

99. When a train stops or is delayed, under circumstances in which it may be overtaken by another train, the flagman must go back immediately with stop signals a sufficient distance to insure full protection. When recalled he may return to his train, first placing two torpedoes on the rail when the conditions require it.

The front of a train must be protected in the same way, when necessary, by the \_\_\_\_\_.

The flagging rule of the New York, New Haven & Hartford, as quoted in the Interstate Commerce Commission's report on the North Haven collision is as follows:

When a train stops or is delayed under circumstances in which it may be overtaken by a following train or needs protection, flagman must go back immediately with danger signals a sufficient distance to insure full protection.

If upon a level or up grade, he will fasten one torpedo on top of rail at least 12 telegraph poles from the rear of his train; then go back 6 poles farther and fasten two more torpedoes on top of rail one rail length apart; if on a down grade he will fasten one torpedo on top of rail at least 18 telegraph poles from the rear of his train, then go back 18 poles farther and place two more torpedoes on top of rail one rail length apart; after doing this he may return to a point between the torpedoes placed and wait for any approaching train, prepared to display proper signals in full view, using every effort to attract attention in season to stop it. When recalled he will look and listen for any approaching train, and if none is located take up the single torpedo nearest the train (leaving the other two) and return. If recalled before placing torpedoes the required distance, a fusee should be lighted and left on the track. If called in after the train which he is protecting has taken a siding to allow a following train to pass, he will leave no torpedoes or fusee. Should the grade be heavy, weather bad, or view likely to be cut off by smoke from passing trains, he must go as much beyond the distance named as circumstances may make necessary to safely protect his train.

In flagging at night great care must be used that a green or white light does not obscure the red. Stop signal should be swung until answered by approaching train.

When, upon single track, it becomes necessary to protect the front of the train or when another track is obstructed the front brakeman (when necessary the fireman) must go forward and use the same precautions.

*Rule No. 99b.*—When the flagman goes back to protect the rear of his train the next brakeman must immediately take the flagman's position on the train and remain there until relieved by the flagman, and on passenger trains the baggage-master must take the place of the front brakeman whenever necessary.

In the Tyrone case the government report does not quote the rule, but says that at a station stop the flagman and conductor are allowed to decide how long a time should be allowed to elapse before flag protection is required; and the report holds that if there had been a rule requiring the flagman to go back in one minute that collision probably could have been thus prevented.

As before stated the purpose here is only to set forth *some* of the conditions of the problem. To go into the subject in any satisfactory detail would require a book. As everybody knows, the elaborate detail which is found in the rule of the New Haven road, and which, with numerous variations, is to be found on some other roads, is the result of extended discussions in American Railway Association committees; which discussions, so far as the association standard is concerned, ended in a rule of a half dozen lines, couched in very general terms,

because of the impossibility of reaching an agreement on anything more specific.

Considering, now, only block signaled roads, the reasons for flagging are few and simple. The block signal system is not perfect; enginemen will not always heed a signal on a post, but will heed a lantern or a stone thrown by the flagman through the cab window; and, thirdly, passengers are perhaps afforded an added sense of security by seeing the flagman go out. A fourth argument is that the audible signal given by the flagman by means of torpedoes is less costly than any fixed audible signal could be. The arguments may be summed up in the statement that all machines and appliances and all persons are liable to failure, and therefore that it is necessary to have duplicate protection.

The arguments against flagging are based (1) on the lesson of experience that when two men are made responsible for doing voluntarily the thing necessary to accomplish a single purpose, each, in many situations, is likely to neglect his own duty, and to depend on the other man; and that there is no practicable way to cure this defect in the scheme; and (2) that flag protection is such a complex problem that no experienced railroad officer has found a satisfactory solution of it. In England they have practically given up the attempt. They still have the rule, in the book, but only rarely does a government inspector discuss the flagman's function; and evidence of any enforcement of the rule seems to be still more rare. Everybody in America puts up with a partial solution of the problem. If, in a given case, the flagman goes back at once, and goes the full distance; and if the following train has not exceeded the speed limit, the flagging will probably be effectual (though if the following train is far behind, and the flagman becomes listless, all will then depend on his torpedoes).

The main difficulty with flagging is the delicacy of the questions which must be settled by the flagman in each case. How long should I wait before starting back? Ten seconds? Or one minute? Or two minutes? The rule requiring the man to go without waiting at all, except in case of regular stops, leaves everything at loose ends. Often a regular stop proves as dangerous as any other. Just what is a regular stop? In many cases this needs interpretation. The Tyrone collision occurred at a regular stop. There, if anywhere, the flagman might properly delay. If he never delays starting, he is likely to have to go back a dozen times on every trip, and either the train will be greatly delayed or will go on without him. Going on without him is all right in many cases, if the rule is observed in the same way by all trains, as the flagmen from the preceding train will be picked up successively; but to depend on men thus picked up is a very unsatisfactory reliance. The preceding train may be going to some different terminal; or a man who has been on duty one hour may be exchanged for one who has been on for 10 hours.

In the Tyrone report Mr. Belnap recommended that the flagman should go back after waiting one minute; but what railroad officer would expect to enforce such a rule with any uniformity? To start in 50 seconds would be wrong, and would delay the train. To wait 80 seconds would be a violation of rule, meriting severe punishment. To start and go only a short distance and then return may be more dangerous than not to go at all, for torpedoes or fusees put down, say, 500 ft. from a train, allow too short a distance for a fast train to stop. It may be said that while the flagman is going the 500 ft. his train could be moved forward a hundred or a thousand feet; but here again there would be much difficulty in enforcing the rule in any systematic way.

A flagman trying to obey the rule is always in doubt whether to go back rapidly or slowly. In two minutes he might easily go 1,000 ft.; but he well knows that a two-minute stop will, in all probability, be perfectly safe without flag protection, and he hesitates to cause the four-minute delay. It is, of course, possible and perhaps probable, that when at last the case happens where a following runner is careless, the flagman, even under the present unworkable rules, will have got back far enough to stop him. Flagging is, at times, effective. But the essential point of the argument is that no rule can be made which is safe and satisfactory to the superintendent and easily understood by the brakeman. It is common to ascribe negligence in flagging in all cases to the laziness, or at least to the dull judgment, of the flagman; but it is by no means certain that this is a fair way to treat the matter. There are plenty of cases where a brakeman possessing a reasonable brakeman's judgment finds himself in perplexity. The book will tell him to settle the doubt by going back; but the most positive orders will often fail to change a life-long habit, as we have seen in the case of Engineman Miller, who, in spite of the superintendent's admonition to lose time in fog, stuck to his habit of making just as good time as he believed possible. The brakeman's habit is to stay with his train if he can. To require him two, ten or forty times a day, deliberately to suspend that habit because, by a little course of reasoning, he reaches the conclusion that he ought to go back, is to put on a brakeman a responsibility for which many tutors of philosophy, logic or mathematics would be none too well fitted. Must we not admit that the only rule that is workable and logical, is to have the man go back at every stop, and always go the full distance? Any relaxation of this requirement introduces uncertainties which no rule-maker or disciplinarian has ever been able to cope with. It seems absurd to have the flagman regularly go back at every passenger-station stop; in a majority of cases it is absolutely useless, whether the stop be two minutes or twice or three times that length; but without such a rule, flagmen are always calculating as to what kind of a train is following, how far back it is, what kind of man is running its engine, and indulging in various speculations; whereas the rule requires them to refrain entirely from these speculations. Can anybody enforce this rule?

These are troubles which immediately affect the flagman; not all of his troubles, by any means. But the superintendent has still others. If there are ice-covered bridges within the flagman's path, or if the temperature is 40 deg. below zero; or if a furious snow storm makes torpedoes unreliable, the protection afforded by the most faithful flagman is of questionable value and the superintendent must avoid unnecessary dependence on it. The flagman may be of heroic temperament, but if he is made up of ordinary human clay, even in part, he will constantly reflect that his heroism is likely to be wasted. At junctions a flagman who goes back is likely to find that, to obey the rule he must go back on two different lines!

The superintendent's most constant difficulty is to get men of the right quality. To get those who are honest and intelligent and who will keep themselves free from whiskey, is not always easy. Wages are now pretty high, but men with the strength of character needed for this work evidently find it easy to get more attractive occupation elsewhere. This seems to be partly due to lack of care on the part of railroad officers in selecting men from outside for the train service; but the unavoidable difficulties are serious. In the freight service most men find little incentive to cultivate themselves either mentally or morally. A successful flagman in that service may be unfit for promotion to the passenger service because he cannot adapt himself to the work of dealing with passengers. Outsiders put into the passenger service without freight experience are in danger of going years without learning some of the important safety-lessons of their calling. In the attempt to get for his passenger trains efficiency, experience and politeness, all in one person, the trainmaster often fails even of fair success. No

sooner has he in some degree purged a new man of his dullness, ignorance or lack of ambition, than the unfavorable effect of too frequent changes is likely to show itself. The trainmaster himself is likely to be transferred or promoted, interrupting an unfinished task; but even if he continue in his position a reasonable time, changes in the men become necessary, for obvious reasons; and fluctuations of passenger business in spring and autumn break up the best of plans. To have a thoroughly satisfactory force of experienced and reliable flagmen at all times, many companies would have to keep on the payroll through dull seasons from 10 to 25 per cent. more than their minimum force. This is so costly that few if any roads do it.

The greatest difficulty of all is that of training men's habits of mind so that they will carry out the rules simply as a matter of duty. Any flagman can see that under the block system his flagging will be of value not once in ten thousand or a hundred thousand or more times. And his duty, the duty to perform a seemingly useless function, is made more difficult by that clause of the rules which authorizes the flagman to use his own judgment, at least to some extent, as to time of starting and distance to be traversed. The rule would be much easier to enforce if it permitted the flagman no discretion whatever.

Every interested reader will recall concrete examples of situations illustrating these perplexities. Just now these examples are numerous on the New Haven road. (Always, on all roads, the perplexities of flagging have been more apparent in the weeks following a disastrous collision. At other times the perplexities are mostly concealed under the flagman's or the conductor's hat.)

At Stamford, recently, a westbound passenger train stopped to change engines a little distance east of the station, the same place where this was done on the fatal twelfth of June. The flagman went back about five or six hundred feet. The stop was about four minutes. It was broad daylight. When the flagman came in he lighted a fusee and stuck it in a tie. The fusee probably would not be seen by an approaching engineman as soon as he would see the rear car of the train, so long as the train stood there. The fusee was useful, if useful at all, simply to provide a time interval after the train had gone out of sight. But, under manual signalling, it is only once in a million or several million times, that another train will come along. Under automatic block signalling, with a rule under which a following train, after having stopped at a stop signal may proceed under control, the fusee is liable to have the effect of encouraging runners to ignore the rule to run under control. The fusee at best is a means of indicating a time interval; and the requiring of a time interval always tends to weaken the men's respect for the space interval. This flagman could fairly be said to be on the ground, alert, ready to flag if flagging should become necessary. Quite likely that was all that was really expected of him; but if so, why have him go back five hundred feet?

Mention has been made of the possible effect of flagging on observing passengers; cases of this kind, or very much like it, observed every day by passengers, serve to give them an unfavorable impression. The flagman's apparent indecision may, indeed, seem to them worse than it really is.

Another westbound train approached Stamford about 8 o'clock on a rainy night, and was stopped farther back, the preceding train having been slow in changing engines. This stop lasted ten or fifteen minutes. The flagman got back a long distance, presumably as far as was required by the rule. The presence of long freight trains on other tracks, and of yard movements not far away, together with numerous lights in houses and street lamps, made it unsafe to depend on one's eyes for the location of anything except at very short range. When the train was ready to go, it had to wait six minutes for the flagman to come in. In such a case, to wait for the flagman (not knowing exactly how long it will take him to come in) or, to go on without him, is a question which the conductor must decide as best he can; the seriousness (or otherwise) of losing six

minutes, the effects of this delay on other trains, the likelihood of picking up another flagman, the number of miles yet to be traversed, all will be taken into account. If there were any doubt of the flagman's faithfulness and intelligence in putting down torpedoes, that also would affect the conductor's decision.

Consideration of cases like this leads to the conviction that trains many times reach the end of the division, ten, twenty, or thirty minutes late, because of unexpected stops and time lost in flagging, when, if the conductor had taken all precaution, at every one of those stops, he would have been nearer sixty minutes late than thirty; in short, that conductors often decide that the circumstances are *not* such that they "may be overtaken by another train" (Rule 99), when such decision really depends on one or more uncertain elements. In other words, that he decides this question by the exercise of his judgment, and that his judgment will sometimes fail. The very fact that, even if his judgment be wrong, no harm results, perhaps, for years, has a constant tendency to weaken the conductor's vigilance. He is in the dangerous position of getting apparently good results from defective means.

Because of what may be called the extreme conservatism of the American railroad mind, difficult questions in train operation have usually been settled, if settled at all, only by the slow process of waiting for error to die a natural death. The foregoing observations are presented as a suggestion that here is

Rapid Transit Company, New York, the Boston Elevated, Boston, and the San Francisco-Oakland Terminal Lines. It is to the effect that the automatic stops on those lines have cured the motormen of their carelessness. The testimony of Paul Winsor, of the Boston Elevated, heretofore given in the *Railway Age Gazette*, is quite definite, to the effect that over-running of signals has been abolished. This point is mentioned here, not by way of advocating automatic train stops, but as evidence of the peculiar value of anything which aids in enforcing strict discipline. Many will say that the automatic stop, as a means of applying brakes, is an undesirable thing; but as a means of convincing runners that every disobedience will be detected, it is a very valuable thing. Experience with derailing switches, and "smash" signals at drawbridges, gives weight to this view. The problem of securing obedience at all signals may be in many respects different on the ordinary railroad from what it is on the Boston Elevated, with its moderate speeds; but, nevertheless, Mr. Winsor's testimony is not to be lightly brushed aside.

### DIESEL LOCOMOTIVE.

A locomotive operated by Diesel oil engines has recently been furnished by Sulzer Brothers, Winterthur, Switzerland, to the

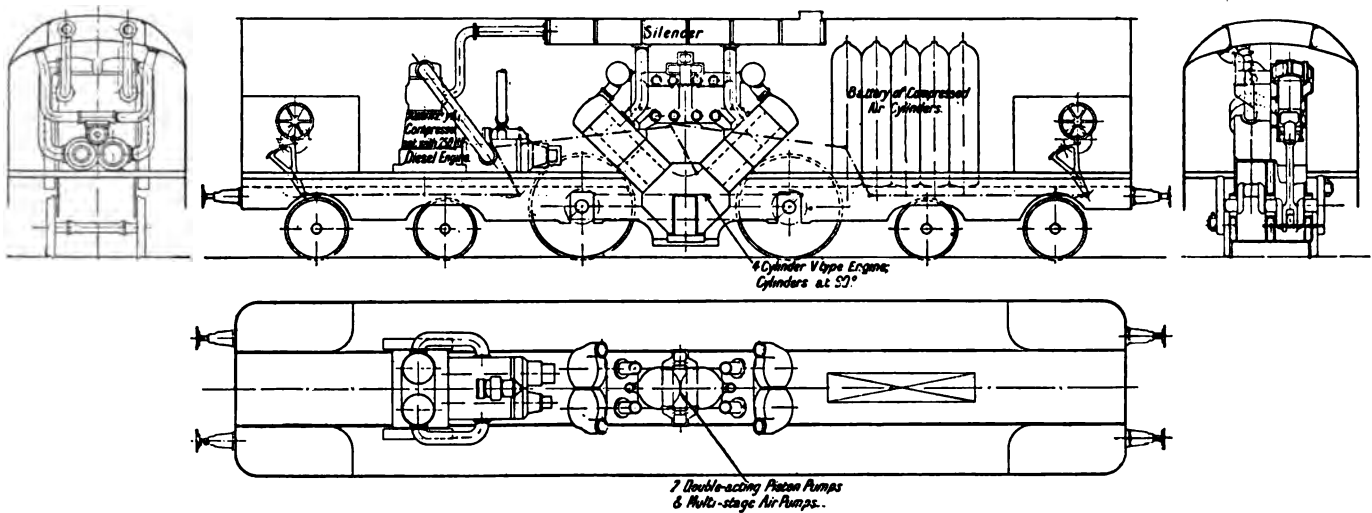

General Arrangement of the Sulzer-Diesel Locomotive.

one difficult question which ought to be settled by some faster process. If they have the appearance of a highly colored argument, fabricated by a pessimist, that should only make it the easier for the optimist to establish the optimistic view.

It was not the intention to lengthen this long article by going into the question of a remedy for the flagging disease, but it will be allowable, perhaps, to recall two suggestions; one by a former superintendent of the Erie, affecting lines worked by the manual block system, and the other by officers of roads equipped with automatic signals, where automatic stops have been used.

The Erie man, arguing with his fellow officers, who stood up for the value and importance of flagging, said: "Very well; if our block signals must be supplemented by flag and torpedoes, let us have the block signal man go down stairs, after each train, and put torpedoes on the track and stand there with his hand flag. If the flagging on the ground is necessary it is necessary at a great many places and times where we cannot trust the train flagman, or the conductor, or both of them, to decide just what to do; and the logical course is to have this flagman, whose location is known and who can be reached at any time by the trainmaster, do the work in a business-like manner."

The other suggestion is from officers of the Interborough

Central Railway Department of the Prussian-Hessian State Railways at Berlin.

According to the Whyte system of classification the locomotive is of the 4-4 type, there being a four-wheel truck on either end with two pairs of driving wheels in the center. The engines are of the four cylinder V type and drive a crank shaft which is connected to the driving axles; there is also an independent air compressor set of about one-quarter the power of the main engines. The compressed air is employed for starting the engine and a number of air cylinders are used to provide storage capacity.

The cylinders are set with the center lines of the barrels at 90 deg.; they have a diameter of 15 in. and a stroke of 21.7 in., and the cranks are 180 deg. apart. The engines are of the reversible, two cycle type and are single acting. The crank shaft has three bearings in a cast steel frame casing carried by the main frames. Each cylinder has a fuel valve through which fuel is injected to the cylinder under a pressure of from 50 to 70 atmospheres; a starting valve for the supply of air to the cylinders at a pressure of 50 atmospheres; and two scavenging valves for low pressure air at about 20 lbs. absolute pressure. The exhaust takes place at the end of the down stroke through ports in the cylinder walls. The valves are driven by two loose eccentrics which can

be thrown over to effect reversing; one eccentric controls all the valves of two cylinders. Between the four cylinders of the main engine are placed two double acting piston pumps and a multi-stage air pump. These are all driven from the connecting rods of two of the main cylinders by means of links and rockers. The three stage air pump acts as a reserve for the auxiliary compressor set and if the latter should fail the engine air pump can supply sufficient air, provided the demand on the locomotive is not too great.

The cab encloses the entire locomotive and the fuel and circulating water are contained in four tanks constructed at the corners. A silencer for the exhaust is provided in the roof over

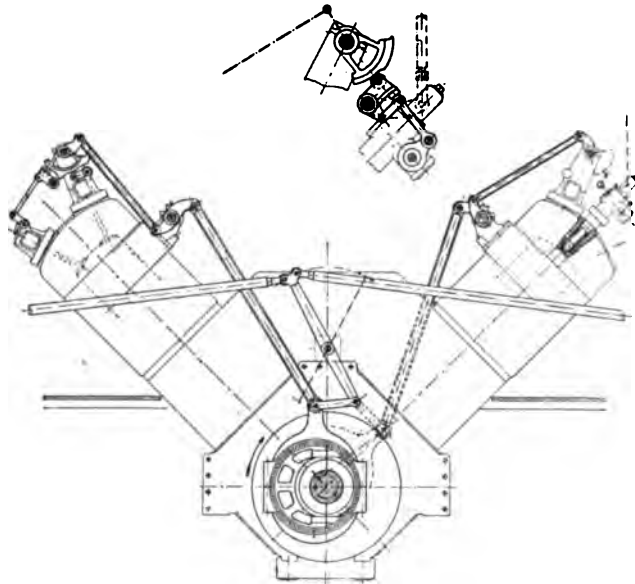

Four-Cylinder V-Type Engines Used on the Diesel Locomotive.

the main engine and the coolers for the jacket water are placed over the cab. The reversing and other mechanism is so arranged that the engine can be controlled from either end. The auxiliary engine is started first by the admission of air from the air reservoir, slowly at first. After the auxiliary has been changed to oil fuel the pressure in the air storage cylinders rises and the air supply is admitted to the main engine, which consequently commences to work. When a speed of about six miles an hour has been reached the starting air valves are thrown out of action and the engine is changed to oil fuel and works normally, the fuel feed and the injection air being controlled according to the speed and power required. In stopping it is only necessary to

cut out the fuel valve and apply the brakes; and in order to reverse, the hand wheel in the cab is operated, locking gear preventing reversing until the fuel valves have been thrown out of gear.

The locomotive was designed for fast passenger traffic and has developed a speed of 62 miles per hour when running at 304 revolutions per minute. It is 54 ft. 6 in. long over all and weighs in working order 95 tons. The driving wheels are 5 ft. 8¼ in. in diameter. Tests were carried out on the Winterthur-Romanshorn line where speeds of from 12 to 60 miles an hour were obtained and trials have since been made on the Berlin-Mannsfeld line. It is reported that the change from air to oil fuel is accomplished without any trouble at a speed of from five to six miles per hour and the reversing arrangements are found to be satisfactory.

**PROSPECTIVE CONGESTION ON PRUSSIAN RAILWAYS.**—It is not surprising that, in view of last year's unprecedented congestion on the Prussian Railway system in the industrial districts of Essen and Westphalia, the Prussian State railway administration has already begun to take active steps so as not to be found napping this year. Although, according to reports from the Berlin chamber of commerce, there are many signs of a slackening in the great activity experienced for some time past in the commercial and industrial world, it is not expected that this will affect the Prussian railways. In fact, the claims on the rolling stock, as far as can be foreseen, will be even greater than last autumn. This opinion is supported by the fact that there is the constantly increasing demand for coal, which will be specially heavy this year. Another reason is that the waterways in the East of Prussia are not likely to relieve the railways. On the contrary, much traffic which formerly went by inland waterways will have to be carried by rail. The traffic on the Oder has been repeatedly interrupted owing to floods, that of the Elbe in consequence of drought, so that neither of these have been able to develop their traffic to the full extent. It is not unlikely, therefore, that a portion of the goods which otherwise would have been carried by water, especially those delayed in delivery, will have to be carried by rail. Moreover, the prospects of the sugar-beetroot and potato harvests are even better than last year, so that in this direction alone there will be a greater demand on the rolling stock this autumn than last. Taking a general view of the whole situation, it may be safely estimated that the railway traffic on the Prussian system in the next three months will surpass the heavy traffic of last autumn. It remains to be seen whether the measures taken by the Prussian railway administration will be so ample as not to cause such a sensational congestion as last year.



Sulzer-Diesel Locomotive for the Prussian-Hessian State Railways.

# RENEWING TWO DOUBLE TRACK SWING SPANS.

Replacing the Bridges on the Jersey Central Over Hackensack and Passaic Rivers and Rebuilding 2¾ Miles of Line.

In connection with the replacement of two swing bridges on the Newark and New York branch of the Central Railroad of New Jersey, the grade has been elevated for about 2¾ miles, the maximum change being about 22 ft. The old bridges which spanned the Passaic and the Hackensack rivers were double track structures but had been operated with a gauntleted single track for several years in order to prevent overloading. It was very desirable to provide an unobstructed double track over these bridges, and it was finally decided that it would be more

eliminate fully 90 per cent. of the bridge movements. In order to keep railway traffic moving continually during the construction work, it was necessary to build a temporary double track line the entire length of the improvement, temporary trestles being driven across the rivers and the old swing bridges moved over to provide temporary draw spans.

## MOVING THE OLD SPANS.

It was necessary to move the old spans from their original location to the new temporary line as quickly as possible so as not to interfere with traffic longer than necessary. This movement was made on scows, the bridges being floated into place on Sunday when there was very little river traffic and train movements were less frequent. The trains that had to be operated to Newark were sent around by way of Elizabethport so that no interference to traffic was occasioned by the work. The scows were 105 ft. long, 31 ft. wide and 9 ft. deep, of very heavy construction, with longitudinal and transverse trusses. The bridges were supported on timber blocking resting on these scows which are located under the floor beams at the midpoints of the two channel spans. The center lines of the scows were painted on the blocking and the center line of the bridge were similarly marked on the floor beams to allow the scows to be accurately and rapidly located at the proper points. The top chords in the three center panels and certain web members of the old trusses were strengthened by timber blocking so that the eye bars could carry compression resulting from the reversal of stresses when the truss was supported on the scows.

The temporary line was located as close as possible to the old one, this distance being fixed by the length of the racks on which the new spans were erected. The old swing spans therefore could not be placed in the temporary structure opposite the new span. As the new swing span over the Passaic was to occupy approximately the same location as the old, it was necessary to shift the old span longitudinally about 100 ft. The tim-



Moving Old Hackensack Draw Span to Temporary Position.

economical to build new structures than to attempt to strengthen the old ones. The decision to build new bridges was also influenced by the fact that this plan provided an opportunity to raise the grade and eliminate a large number of bridge movements.

The old line was only a little above the meadows which lie between and along the two rivers, but the new grade will be

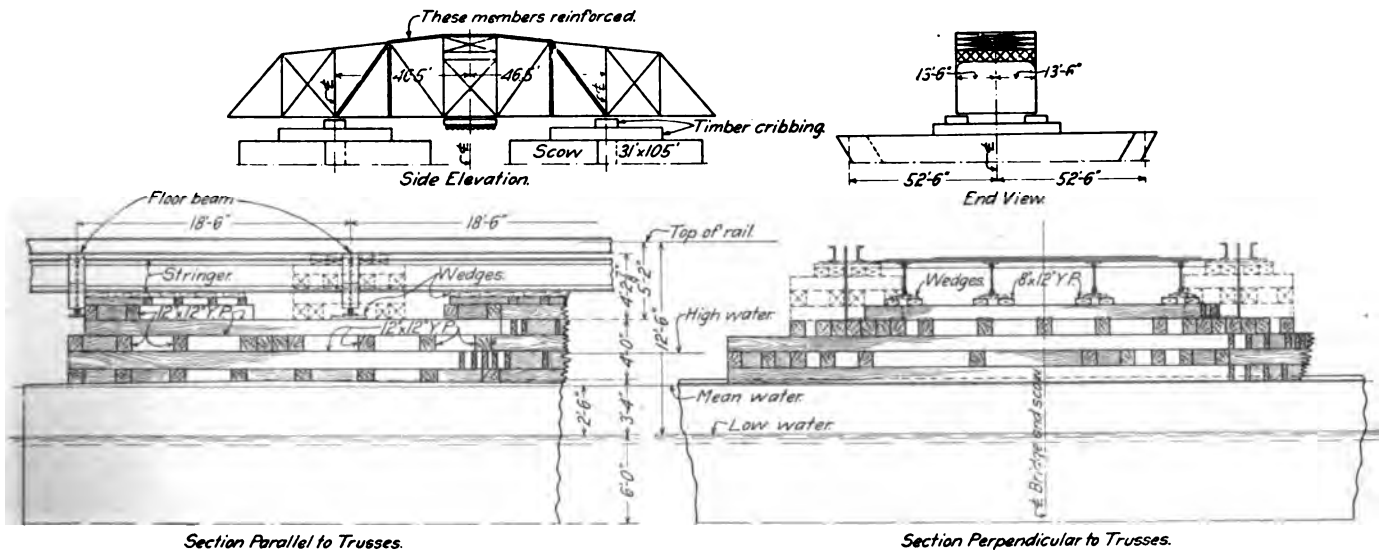

Details of Method of Carrying Old Draw Span on Two Barges.

on a fill from 15 to 30 ft. high, beginning at West Side avenue, Jersey City, extending level across the two rivers and dropping west of the Passaic on a 0.5 per cent. grade to a connection with the old grade near the crossing of the Pennsylvania and the Lehigh Valley. It is thought that this elevation, which gives 25 ft. clearance above mean high water at the two rivers will

ber cribbing and fenders of the old span limited the space for working, making it necessary to move this span transversely about 75 ft. to clear the old piers and crib work, then longitudinally to a point opposite the new location and then transversely again until it could be lowered on the new center pier. The location of the new span at the Hackensack was far

enough from that of the old to allow the temporary position of the old span to be fixed opposite its original location. The movement in this case therefore was entirely transverse.

In moving the old bridges, the temporary trestle was first driven, the temporary center pier built and all equipment necessary was provided, the plans for carrying out the work having been very carefully prepared. Traffic was turned off at midnight and the actual operation of moving the bridge began about 3 o'clock in the morning. The two scows which had been located above the bridge with their cabin ends up-stream were floated under the bridge at low tide, carrying sufficient water ballast to allow the blocking to clear the bottoms of the floor beams. As the tide rose, the sea cocks were opened to prevent the scows lifting the bridge until all the blocking had been placed. The stringers and chords were blocked up as well as the floor beams, care being taken to keep the pressure uniform at all points of support. The bridge was raised by pumping out all the water ballast, this being done on a rising tide. The movement was made by hoisting engines, the lines being attached to pile drivers used on the temporary trestle. During the moving of the span the pivot, spider and turntable were carried from the chords and floor beams by yoke timbers and vertical hook and screw bolts.

When the bridge was in position over the new pivot pier it was lowered by means of the water ballast and the scows were removed up-stream. The lowering of the bridges was also done on a rising tide and the elevation of the Hackensack bridge in the new location was about 2 ft. higher than in the old. The old Passaic bridge which was 217 ft. long and weighed 400 tons, was moved in 50 min., although traffic was not turned over in its new location until 4 p. m. Sunday. When the Hackensack bridge was moved, the line was out of service from 12 midnight to 12 noon.

CONSTRUCTION OF NEW LINE.

The temporary double track on the new fill was placed as close as a 1:1 slope would allow. The material was kept from overflowing the temporary tracks by crib work laid up by hand of stone picked from the filling material. This stone cribbing sank quite readily into the soft surface of the meadows and no attempt was made to stop it. As fast as it sank additional material was placed on top and the presence of this cribbing below the surface proved very effective in preventing displacement of the temporary track due to upheavals of the soft soil under the load of the new fill. All crowding of the material had to go to the opposite side. In some places it was necessary to limit this spreading on both sides, particularly at a point just west of the Passaic where a manufacturing plant is located very close to the line and considerable damage would have been done by an upheaval of material under the buildings.

The material used for the fill was brought in by scows, being secured from building excavation and disposal stations about New York City. The material was unloaded from the scows to standard gage cars on temporary trestles located on both sides of the Passaic and on the east side of the Hackensack. About 1,500,000 yds. were required for the fill.

THE NEW DRAW SPANS.

The new draw spans are exactly alike, being about 250 ft. long overall and providing two 100-ft. channels. Considerable saving was made both in design and erection by the use of identical structures. The Passaic bridge has one girder approach span on the west side and four on the east, and the Hackensack bridge has six approach spans on the west and five on the east. These spans are all deck girders ranging in length from 88 ft. to 110 ft. The piers and abutments are of concrete and ashlar masonry, the latter being used between elevations 2 ft. below low water and 2 ft. above high water as a protection against ice and the action of salt water on concrete. The piers are rounded at both ends. They are supported on piles driven about 40 ft., with a steam hammer and follower,

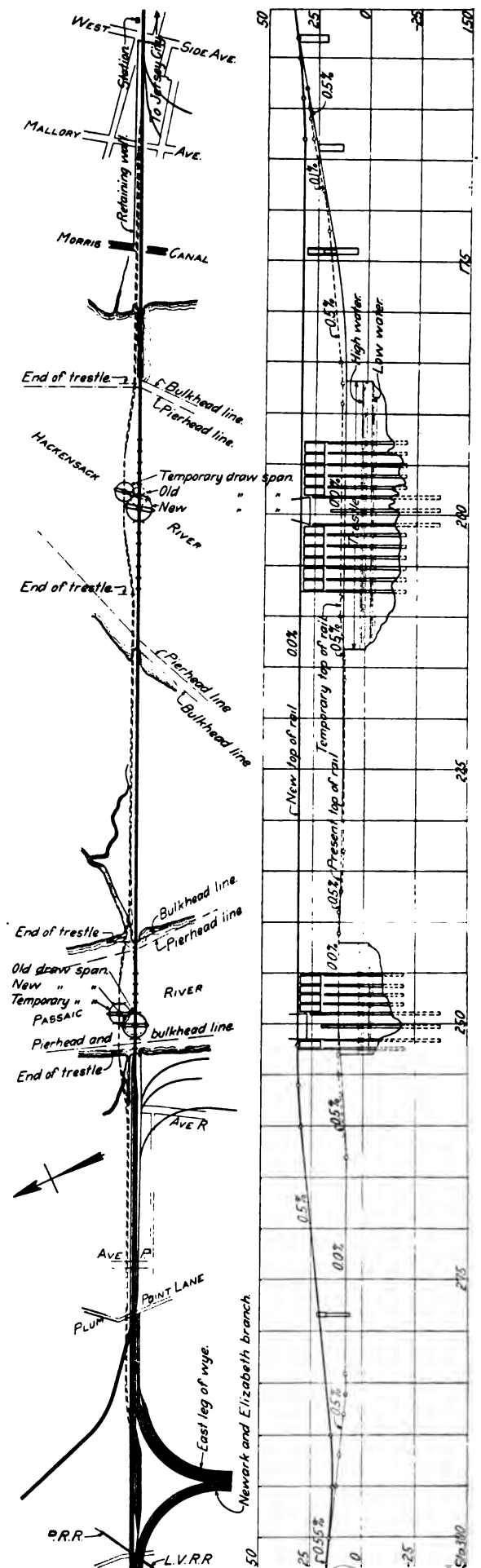

Plan and Profile of Central New Jersey Improvements Across Hackensack and Passaic Rivers.

the tops of piles being 1½ ft. above pier footings. The deepest pier is 30 ft. below low water, most of the approach piers extending down from 16 to 20 ft. Cofferdams of Lackawanna steel sheet piling were used for the channel piers and timber dams for the piers in shallow water. The concrete forms were

scows and the mixers were also located on scows. One derrick was used to feed the mixer and another to take the concrete from the mixing plant and deposit it in the piers. The Hackensack bridge required 2,500 piles, 11,000 yds. of concrete and 1,250 yds. of ashlar masonry. The Passaic bridge required



Stone Cribbing Along 20-ft. Fill for New Line.

placed under water and the concrete in the shaft of the pier was deposited by a bottom dump bucket also under water. When concrete had been placed up to an elevation 2 ft. below low water, the piers were pumped out and the ashlar masonry placed in the dry. All concrete material was brought in on

1,700 piles, 8,500 yds. of concrete and 700 yds. of ashlar masonry. In dredging the channels to a uniform depth of 16 ft. below low water, 500,000 yds. of material was removed.

After completing the new pivot piers permanent racks were built on which falsework for the erection of the new swing spans



New Hackensack River Bridge Under Construction; Draw Span Erected in Open Position, Piers for West Approach Being Built in Foreground.



was carried. These permanent racks are of creosoted piles 60 ft. long, the sheathing and clusters being of white oak. All steel was brought in on scows and erected by derricks. The new spans will be operated by Lidgerwood engines.

#### OTHER STRUCTURES.

In addition to the two river crossings, the track elevation involved a number of minor structures, three over streets and one over the Morris canal. Mallory avenue, Jersey City, near the east end of the work is crossed by a 60-ft. deck girder, the abutments being built for four tracks and the steel work for two. The Morris canal is crossed on a 60-ft. segmental arch of reinforced concrete which replaces a half-through steel span. In



The New Line Across the Passaic River, Showing Temporary Line to Left.

this case also, the abutments have been built for four tracks. Near the west end of the work Avenue R is crossed on a concrete arch structure consisting of two arches 26 ft. wide with an 8-ft. space between them. A single track will be laid over each of these arches at present, the wide track spacing being provided to allow the building of an island platform for the transfer of passengers. A stairway will extend from the street to this platform between the two arches. If it is desired to add two more tracks in the future, this intermediate space can be filled in by an arch section and the structure will then be of full four-track width. Avenue P is crossed by a four-track steel structure of through girders encased in concrete.

This improvement work was begun in August, 1911. It has been prosecuted continuously since that time and was put in



Double Concrete Arch Structure Over Avenue R.

service October 5; although the work of tearing out the old bridges and finishing some of the minor improvements will not be done before next spring. The entire work was handled under the direction of Joseph O. Osgood, chief engineer, Central Railroad of New Jersey and A. E. Owen, principal assistant engineer. J. J. Yates, bridge engineer was in charge of the design of structures, and L. M. Hannaford was resident engineer on the work. Henry Steers, Inc., New York, was the contractor handling the building of the temporary trestle and the new embankment, moving the draw spans and building the permanent piers and all concrete bridges. The American Bridge

Company fabricated and erected the steel for the two draw spans, Mallory avenue and Avenue P. We are indebted to the engineering department of the Central Railroad of New Jersey for the above information.

## WARTIME RAILROADING IN MEXICO.\*

BY MAJOR CHARLES HINE,

Vice-President, Southern Pacific Railroad of Mexico.

For nearly three years past Mexico has suffered from what are politely termed "political conditions." The various participants have expressed their opinions in terms of force and violence. Thousands of lives have been sacrificed; millions of dollars worth of property have been destroyed. Railways have suffered severe losses, both by the destruction of physical property and by the paralysis of revenues, resulting from prolonged interruptions to traffic.

The normal method of procedure includes the burning of all wooden bridges in the theater of operations. The smaller the band, the greater seems its conception of the importance of preventing pursuit by destroying railway bridges. The topography and climatology of Mexico are such that provision must be made for adequate drainage in cases of sudden and severe rainfall. The greater part of these openings are as yet bridged by wooden structures. Traffic can, therefore, easily be tied up and operation nullified by a few bridge burners. The Southern Pacific of Mexico alone has found over 300 bridges burned in the last three years. The number destroyed on the other railways of the republic must run into the thousands.

It may be stated, for easy remembrance, that there are something like 16,000 miles of railway in the republic of Mexico. A little over one-half of this mileage, or something like 8,000 miles, is comprised in the National Railways of Mexico, known among English-speaking people in Mexico as "the merger." This system includes, among other subsidiaries, the old National Railroad of Mexico, the Mexican Central, the Mexican International, the Inter-Oceanic (narrow gage), the Mexican Southern (narrow gage), the Vera Cruz to Isthmus and the Pan American. These various subsidiary corporations are operated under leases and different working arrangements by the National Railways of Mexico, in effect both a holding and an operating company. A majority of the stock of this controlling company is owned by the federal government of Mexico. The bonds are largely held in foreign countries, including the United States. Although certain ministers and officials of the Mexican federal government are ex-officio members of the board of directors, the National railways of Mexico have a working president, E. N. Brown, and all the corporate, executive, general and minor officials usually found on American railways. This unique condition is sometimes described as "government partnership" in contradistinction to the government ownership of other countries.

The next largest railway under single control is the Southern Pacific of Mexico, owned outright by the Southern Pacific Company, and of which 1,250 miles have thus far been finished. The main line of this road is not yet completed. It reached the city of Tepic, the capital of the territory of Tepic, in February, 1912. Previously, some 40 miles had been constructed, north from Orendain Junction, on the National Railways (near Guadalajara, state of Jalisco, the second city in the republic). The above-mentioned "political conditions" have prevented the construction of the intervening portion of approximately 100 miles.

Next in mileage comes the Mexico Northwestern, of approximately 500 miles, owned by Dr. F. S. Pearson and associates, and operated in connection with large lumber mills at El Paso, Texas, at Pearson and at Madera in the state of Chihuahua. This road, lying entirely within the much troubled state of Chihuahua, has probably suffered the greatest percentage of depredations per mile of line of any railway in the republic.

The fourth railway in mileage is the Mexican Railway, some

\*A paper read before the St. Louis Railway Club, October 10.

400 miles, owned by English capital and affectionately called the "Queen's Own." This is the strong line between the City of Mexico and Vera Cruz, a port rich in commerce and famous in history as the three times military base of a conquering foe,—the Spaniards in 1519, the Americans in 1847, and the French in 1862.

The Tehuantepec National, 188 miles long, running from the port of Salina Cruz on the Pacific, to Coatzacoalcas on the Gulf of Mexico, is owned by the Federal Government of Mexico, but is being operated for a term of years by S. Pearson's Sons Company, Limited, who constructed the splendid harbor and terminal facilities at both ends of this shortest of transcontinental lines. A portion of this road forms the connecting link between the Vera Cruz to Isthmus (old Vera Cruz and Pacific) at Santa Lucrecia, and the Pan American at Picacho.

The remaining railway mileage of the republic consists for the most part of small independent branch lines leading to mines and other industries, and in many cases is of narrow gage.

It has been the good fortune of the writer to travel over every mile of main line and over numerous branch lines in the republic of Mexico. While so doing, he has visited 23 of its 27 states, and resided for a period at its capital, the wonderful and fascinating City of Mexico. For nearly two years past, with headquarters at Tucson, Arizona, he has served as the senior vice-president of the Southern Pacific of Mexico, and of the Arizona Eastern. The president of these lines, and their principal builder, is the distinguished engineer and railway executive, Epes Randolph.

In the 20 months since February, 1912, when the second of recent Mexican revolutions was started, the Southern Pacific of Mexico has been in full operation only 6 months. During the other 14 months from 10 per cent. to 80 per cent. of its mileage has been out of commission at various times and in various places. At first the officials, who are all Americans, and the employees who are nearly 90 per cent. Mexicans, strained every nerve to crib bridges and to resume traffic. As time has worn on, however, all reserve energy has naturally been dissipated, the abnormal has become the normal, and the exceptional has lapsed into the routine. A train despatcher is not startled if his wire suddenly goes down before the orders are completed. He knows from experience that the wire may not come up until perhaps tomorrow, next week, or mayhap next month or next year. Occasionally the attacking band will take possession of the locomotive and burn some or all of the cars in the train. Usually, however, in the course of a week or two the wire comes up and a conductor asks for running orders from an office many miles from where last located. Such primitive conditions have developed splendid initiative and resourcefulness on the part of officials and employees of all grades. From the president, who happened to be on the first train held up by armed force, down to the humblest laborer, all have followed Rule L of the standard code, reading: "In case of danger to the company's property, employees must unite to protect it." Ofttimes this has meant dauntless and unflinching exposure to rifle or cannon fire. Habitually, it has entailed inconvenience and physical hardship. Officials who normally use comfortable business cars have taken to small motor cars, to track velocipedes, to push cars, or have traveled many miles on foot. On one occasion the writer's motor car was run by a man who had been a railroader, a frontier deputy marshal, and a chauffeur. For the particular trip in question he united the desirable qualities of a careful motorman, a crack shot and a good cook. The first night was spent in a tool house, one night in a freight house; another in a waiting room and still another in the open country. The car was towed around burned bridges through the arroyos (channels of dry streams).

On another trip a good-sized river had to be crossed, the long trestle approach to the steel bridge having been burned some weeks before. Visions of swimming the river like Funston in the Philippines were ended when the thoughtfulness of an assistant superintendent showed a section gang as water rats

towing a raft made of ties. This interchangeability of function is typical of the all-round training inculcated on the Southern Pacific of Mexico by the unit system of organization. Two years of complete and consistent application of the underlying principles of this rational and practical system have produced gratifying results. Today every department, including traffic and accounting, has available from one to three developed and tested understudies for every official position. Coincidentally during the only period of eight months when conditions approached normal, the operating ratio with normal maintenance charges fell from 97 to 78 per cent.

In May, 1912, after operation of the Sinaloa division had been suspended for over three weeks, it was deemed advisable to move all obtainable equipment north to Empalme, Sonora, near Guaymas, where conditions were tranquil. There were only a dozen locomotives at division headquarters in Mazatlan, Sinaloa, 275 miles south of San Blas, Sinaloa, the north end of the division, and a total of some 500 cars within reach. It was feared that insurrectos might cripple the movement by burning bridges between trains. Not only did bridges have to be hurriedly cribbed, but water tanks had to be repaired, some having been riddled with bullets.

On Monday morning the procession started with a train order reading somewhat as follows: "All engines on division run extra to San Blas with right over all southbound trains until 10:00 p. m. Friday, May 10, and protecting carefully against following trains." Some 60 hours later the senior vice-president, renewing his yardmaster days, tied up the last train on the main track, at San Blas, and then issued an order congratulating the Sinaloa division, through its superintendent, on a performance easy anywhere else, but most difficult under the circumstances.

Regular traffic was not resumed for several weeks. Meantime a "cruiser train" was put on. Passengers rode in the cabooses. No cars were left at stations, but freight offered was loaded in empties in the train. After cruising all day, the train tied up wherever night overtook it. The danger of encountering a hole instead of a bridge precludes much night running in times like these.

On March 5, 1913, the state of Sonora revolted against the newly established Huerta government, and seized that portion of the Southern Pacific of Mexico lying north of Empalme. For six weeks the officials of the road were powerless. Operation was carried on from Hermosillo, the capital of the state of Sonora, by the state officials, with six locomotives and other equipment forcibly seized. Methods of alleged confiscation of railway property in the United States are perhaps crude after all. Six weeks of such operation gave the state officials their fill. Outgo so exceeded income that the road was unconditionally returned to its owners.

It is not the mission of this paper to discuss the political, economic and military conditions in Mexico, or to venture into the realm of conjecture as to probable outcome. Its main purpose is to record an appreciation of sustained performance, both creditable to the many individuals concerned and so consistent with those high ideals of duty which are characteristic of red-blooded railroad men the world over.

**AUSTRALIAN RAILWAY DEVELOPMENT.**—During the last two years a greater disposition has been shown by the various state governments of Australia to come together with a view to railway construction in border districts. These areas, consisting in many cases of very good land, have been neglected in the past and much inconvenience has been caused through lack of railway communication which would have been provided but for interstate jealousies. Geographically these districts belong to one state, while legally they belong to another. Consequently railway construction in them was neglected. Now, however, it has been arranged to extend several Victoria railways into the southern parts of New South Wales and South Australia, and to connect northwest Victoria with the South Australian lines.

### RECORD OF A LEHIGH VALLEY LOCOMOTIVE.

The new class K-3 Pacific type locomotives on the Lehigh Valley have, since being placed in service, been hauling heavy trains under difficult conditions. These locomotives weigh in working order 262,000 lbs., and have a weight on drivers of 161,900 lbs. The driving wheels are 77 in. in diameter and the

Fairview, at an average speed of 38.1 miles per hour, without assistance. The average grade on this part of the road, which is in the Blue Ridge range in Pennsylvania, is 42.1 ft. per mile and the maximum 67.9 ft. per mile. It will be seen from the chart that between Hays Creek and Bridgeport, where the grade is 34.8 ft. per mile, the speed reached 50 miles per hour. A profile of this section of the Lehigh Valley is shown in the accompanying illustration, which also gives a speed chart. The

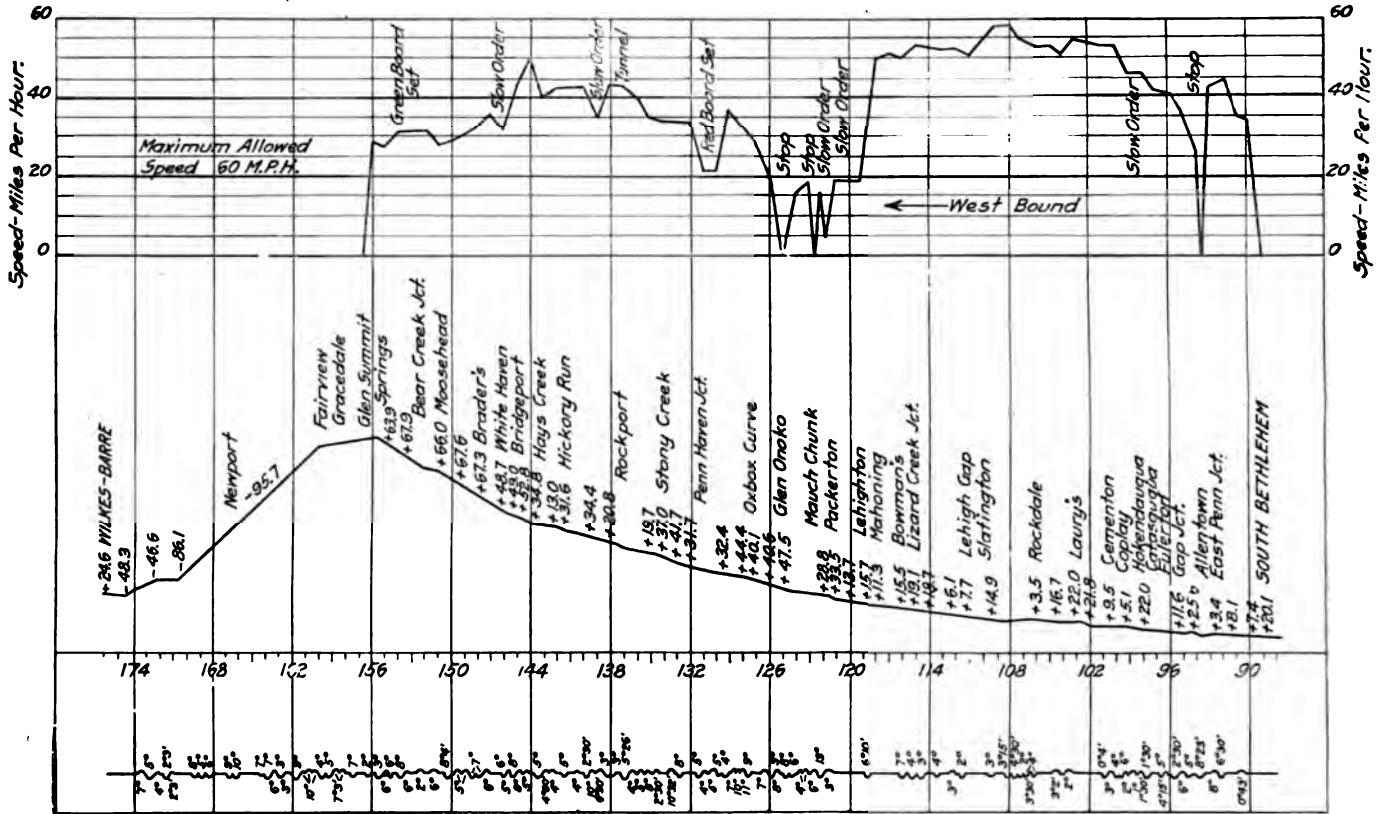

Profile of Part of the Lehigh Valley and Speed Diagram of a Run by a Pacific Type Locomotive Hauling Eight Steel Cars.

cylinders are 25 in. in diameter x 28 in. stroke. The boiler pressure is 215 lbs. per sq. in., and superheaters are used.

On September 6, 1913, locomotive 2010, hauling train No. 9, the Black Diamond Express, an all-steel train made up of baggage-buffet, dining and six Pullman chair cars, eight in all, covered the 24 miles up Mount Nescopec from Penn Haven to

dead weight of the train behind the tender was 603 tons. Using the American Locomotive Company's formula, the tractive effort at Brader's Curve near White Haven, Pa., was 22,540 lbs., or 54.25 per cent. of the maximum tractive effort of the locomotive. These locomotives were designed by the motive power department of the Lehigh Valley.

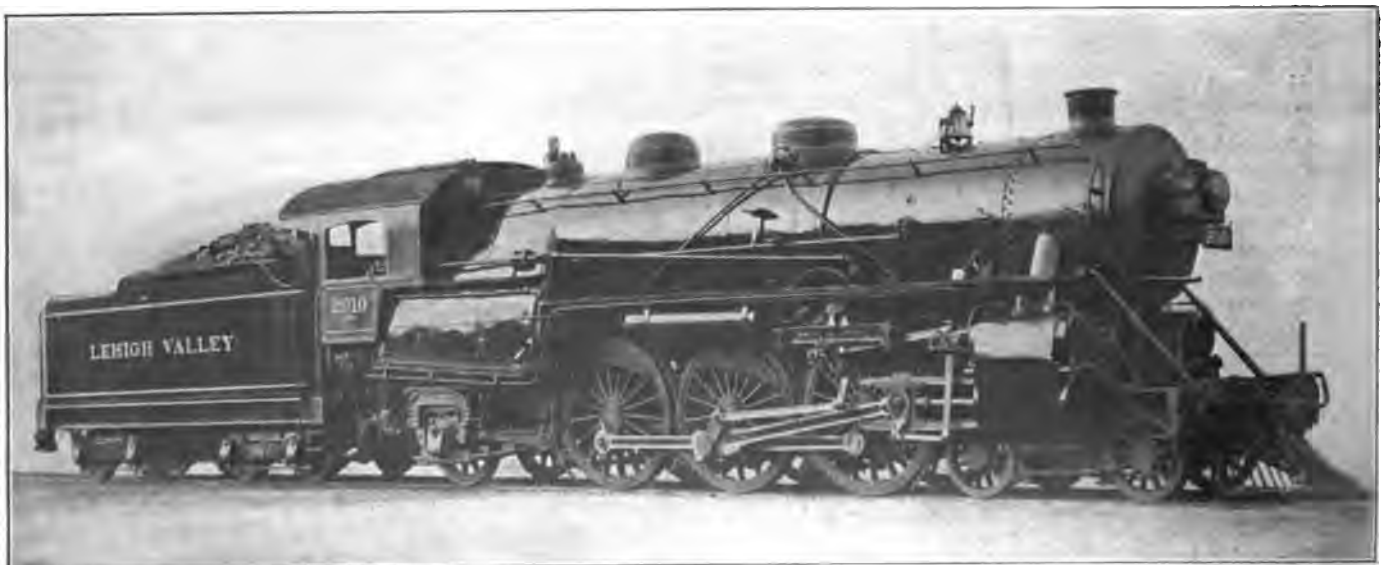

Pacific Type Locomotive Used in Heavy Passenger Service on the Lehigh Valley.

# RAILWAY FIRE PROTECTION ASSOCIATION.

Organization Formed at Chicago to Study Methods of Fire Protection and Prevention.— Abstracts of Papers Presented.

The Railway Fire Protection Association was organized at a meeting at the Hotel Sherman, Chicago, on October 7 and 8, with 40 members, representing the fire protection or insurance departments of as many railways. A constitution and by-laws were adopted, which provide that "The object of this Association shall be to promote the interest in and improve the methods of fire protection and prevention; to obtain and circulate information on these subjects, and secure the co-operation of its members in establishing proper safeguards against loss of property and life by fire, and to standardize practices through the interchange of ideas and experiences with regard to such matters in connection with railway properties."

The action of the association is to be considered advisory and not mandatory. Any representatives of railway companies interested in fire protection and prevention are eligible to membership. The annual meeting is to be held on the first Tuesday in October, the location to be selected by the executive committee, and special meetings may be called by the president or executive committee.

Officers were elected as follows: President, F. H. Elmore, superintendent of insurance, Southern, Washington, D. C.; vice-president, P. Hevener, assistant supervisor of insurance fund, Rock Island Lines, Chicago; secretary-treasurer, C. B. Edwards, fire insurance agent, Mobile & Ohio, Mobile, Ala. Executive committee, R. H. Newbern, superintendent insurance department, Pennsylvania, Philadelphia; Col. B. W. Dunn, chief inspector Bureau for the Safe Transportation of Explosives, Inflammables, and Other Dangerous Articles, New York; B. S. Mace, superintendent of insurance, Baltimore & Ohio, Baltimore; G. G. Tunell, insurance commissioner, Atchison, Topeka & Santa Fe, Chicago; N. Searles, insurance superintendent, Southern Pacific, San Francisco, Cal.; W. S. Langford, insurance department, New York Central Lines, New York.

Following the organization session on October 7, W. H. Merrill, manager Underwriters' Laboratories, Inc., Chicago, gave a description of the work of the laboratories, after which the members paid a visit to the plant to witness some tests arranged by Mr. Merrill.

The program on Wednesday morning included nine papers and addresses. Abstracts of the principal papers are as follows:

## FIRE PROTECTION.

Charles N. Rambo, superintendent, Mutual Fire, Marine and Inland Insurance Company, presented a paper on "Fire Protection Applied to Railroad Properties."

The subject of fire protection in a broad sense includes that of fire prevention which concerns the removal of the causes of fires. The essential features to be considered by those who study the problem of fire protection are:

First, to so construct buildings on fire-resisting lines as to minimize the possibility of fire starting and prevent its unrestricted spread and opportunity for serious loss. The proper time to guard buildings against loss by fire is during their construction. One of the reasons why this is not always done, unfortunately, is on account of the initial cost. We must encourage the use of fire-resisting materials, the division of large areas as far as possible and the protection of buildings exposing each other. We have too frequently seen a class of buildings on railroads that is apt to furnish fuel for large conflagrations.

Second, to prevent fire from starting through the reduction and safeguarding of hazards inherent to the particular

property. Elimination of the possibility of fires starting should be as carefully considered as the question of good construction and protection.

Third, to provide adequate private and public facilities for extinguishing a fire should it start and be prepared to fight a small fire before it becomes dangerous. All of the expense for the installation of fire fighting equipment, water supplies, etc., is of no avail, however, if the means to promptly use it is not trained and ready, and if it is not properly cared for and kept in serviceable condition.

One of the first demands in connection with the study of fire prevention is that of good housekeeping, involving a multiplicity of detailed enforcements that will insure it through a large property as a matter of daily duty and through which means the possibility of fires may be largely avoided. This can be accomplished by the appointment of employees in each portion of a property with such authority as may be necessary, to see that cleanliness is observed and through the posting of official notices in prominent places requiring the carrying out of fire protection rules so prepared as to meet conditions usually found in railroad properties.

The protection of properties against fire is an important part of the duty of every officer and employee. Every fire in railroad property should be made the personal responsibility of some employee. It must be remembered that the majority of fire losses are preventable and that they are largely a matter of lack of cleanliness and carefulness, and that the great study of prevention must be along those lines.

A very good classification of hazards, recently made by a prominent insurance official, divided them into physical, moral and temperamental. Those which are particularly applicable to railroad properties, I believe, are the physical hazard and the temperamental hazard; the first including such as are inherent in the property and its use, such as construction and the hazard of operation; the second including that which would be attributed to carelessness which produces fires, not purposely, but those which could have been prevented by a study of the causes of fires, with less indifference as to the effects which follow or as to the remedies to be applied.

With the consideration of the subject of building construction and the careful and systematic guarding of the housekeeping and operation to reduce or avoid hazards, we include that of fire extinguishing apparatus. This subject necessarily is one of great detail and brings out the study of the extent and character of the properties and the natural conditions surrounding them, and their use and occupancy. The class of appliances will necessarily cover a wide range, starting, however, with the idea of having an ample supply of water to meet the maximum conditions that might arise. Careful study is necessary to determine the specific character of fire extinguishing devices required to meet the demands of each class of property. These include the use of a system of automatic protection which is the best class that may be considered, and which is recognized as the only one producing the maximum of efficiency and success in controlling fires; water mains and fire hydrant systems under ample volume and pressure from public or private reservoir or other source of supply, with incidental fire pumps, elevated tanks, stand-pipes, fire hose, fire extinguishers, steam jets, sand pails, water barrels and pails; all of which must be studied and installed with a due regard to their relative values. An important fire fighting agency on railroad properties is the locomotive or yard engine used at terminals and large yards

remote from public protection so equipped for supplying water with the aid of fire hose as to give good service in event of fires in rolling equipment and its lading.

Fire alarm systems are an important factor, particularly in large properties, to obtain prompt use of fire appliances through the prompt summoning of drilled employees and municipal departments. The success of the fire prevention idea must be due largely to well organized forces in all departments. Without system and organization through the help and authority of executives or the general management, such matters cannot be made an important factor with the men. The prevention of the occurrence of those things which hinder or retard the progress of operation or which are a menace to life and property is brought about or is reduced by education through instructions, rules, etc., issued under an executive order. In this way co-operation is secured amongst the rank and file.

Fires, like accidents, happen at unexpected times. Continued vigilance is therefore essential, and without a general co-operation and knowledge of dangers we cannot escape their consequences. The organization of the fire prevention and protection work on railroads must be undertaken with intelligence and a due regard to local conditions. It is necessary that the importance of the work be recognized by all in authority, the chief executives, the general manager, superintendents, foremen and agents in charge of property; all educated to the idea that there should be harmony of action. Education as to fire prevention requires thorough publicity that all employees may be advised of its scope and that it may reach all parts of a system and that the old and prevalent idea of security against fire damage may be eliminated.

Fires, even though promptly discovered, can very often not be handled by employees because of lack of fire fighting equipment or lack of knowledge of how to handle it, and because it is quite usual in such contingencies for people to "lose their heads." Fires have to be scientifically and carefully sought out and fought. Experience has shown that the efforts of undrilled employees, however well intended, will not control a fire as promptly as a disciplined force, made familiar with the protective apparatus by regular drill and practice.

Rigid and systematic inspection of all fire apparatus should also be made by specially delegated employees, preferably members of fire brigades, at least once a week; everything down to the smallest piece of apparatus should be in its place and in good order ready for use, and a report of such inspection should be made to those in authority.

Fire prevention committees, fire marshals, chiefs or captains of fire brigades are all necessary parts of an efficient organization, and the inspection of buildings and their valuable contents for fire hazards by such committees or members of fire departments should not be treated in any light manner. Members of fire departments, possibly uniformed or otherwise designated with authority, should be especially delegated to make at least weekly inspections and report to the authorities in charge on the conditions, and day and night watchmen should patrol all parts of the property for the same purpose, having their tours properly recorded on approved devices, to assure efficiency.

There should be monthly conferences of officers or local committees at which matters of general interest might be considered with a view of continuing efforts for substantial improvements, for with all reasonable precaution there is still the factor that relaxation may be fatal.

In passing I might add that the improved construction in railway rolling equipment should eventually work a great factor of saving in the loss by fire on railroads, for a large part of their loss has been brought about through inflammable construction of equipment and character of its lading. With the reduction in the amount of inflammable equipment, and safer methods of transportation in connection with haz-

ardous commodities under direction of the Bureau of Explosives, fires may be restricted in large congested yards.

#### CAUSES OF FIRES.

E. B. Berry, chief inspector, Southern Railway, Washington, D. C., presented the following paper on "Causes of Fires":

We must gain a thorough knowledge and understanding of the cause or origin of fires before we may deal with the subject of fire prevention. I have not been able to secure sufficient data to present an exhaustive report, but I have the fire records of three of the larger railroads covering a period of two years which show 4,275 fires, with a loss of \$1,810,000.

Eliminating 285 fires, charged to miscellaneous origins, such as boiler explosions, friction from brake shoes, hot journals, etc., all of which are causes of infrequent occurrence, there remain 3,990 fires, or 93 per cent. of the total number, with a loss of \$1,580,000, which originated from 18 causes. These causes are mentioned in the order of their importance.

1. 1784 fires, 41 per cent., with a loss of \$52,000, were caused by loading hot cinders into cars, which includes the slacking of lime in trash cars.

2. 707 fires, 17 per cent., with a loss of \$200,000, were caused by flying sparks.

3. 503 fires, 8 per cent., with a loss of \$298,000, were charged to an unknown origin.

4. 213 fires, with a loss of \$136,000, were caused by the burning of adjacent property.

5. 156 fires, with a loss of \$46,000, were caused by defective heating appliances, or careless handling of same.

6. 68 fires, with a loss of \$23,000, were caused by defective lighting appliances, or the careless handling of same.

7. 148 fires, with a loss of \$240,000, were charged to wrecks.

8. 130 fires, with a loss of \$77,000, were caused by live coals dropped by engines.

9. 67 fires, with a loss of \$64,000, were charged to incendiarism.

10. 59 fires, with a loss of \$57,000, were caused by the careless handling of torches and open lamps.

11. 47 fires, with a loss of \$66,000, were caused by tramps.

12. 42 fires, with a loss of \$13,000, were caused by spontaneous combustion.

13. 30 fires, with a loss of \$30,000, were caused by friction matches.

14. 16 fires, with a loss of \$34,000, were caused by smoking.

15. 15 fires, with a loss of \$9,000, were caused by careless burning of grass and rubbish around tracks and building.

16. 4 fires, with a loss of \$90,000, were caused by overheated boilers.

17. 2 fires, with a loss of \$140,000, were caused by oily waste and wooden lockers.

18. 2 fires, with a loss of \$9,000, were caused by defective insulation of oil burning forges.

I have examined records of my own road for the past ten years, and have looked over a few records of other roads, and I am of the opinion, if all the railroad fire records were examined, the 18 causes mentioned would be found to be the origin of 75 per cent. of the fire loss on railroads. I will venture to say further that losses charged to each of the 18 causes will be approximately uniform each year. In other words, it would seem entirely proper to charge a specific annual loss to each of these 18 causes. Of the 3,990 fires attributed to the 18 causes, 76 per cent., or 3,255 fires originated from avoidable causes, which in the last analysis means nothing more than carelessness.

I desire to dwell for a moment on fire losses caused by flying sparks and fires reported of an unknown origin. Under the first class, there were 707 fires, with a loss of \$200,000. We know that engines cannot operate, without throwing

sparks, and under the most favorable conditions, certain fire losses are unavoidable. I believe, however, that losses from this cause can be very much reduced. Seven or eight years ago, cotton fires on the Southern reached an annual loss of \$100,000 to \$150,000. Something had to be done, and after a conference of the inspection department, special cotton inspections were inaugurated. Each cotton point was visited, conditions investigated, agents cautioned as to the danger from flying sparks, and their co-operation requested. Fire protection apparatus was kept ready for instant service, and engineers were instructed to pass cotton platforms without working steam. Superintendents were instructed to make a special effort to get all cotton loaded before night, and to see that cars were in good condition, with doors securely closed, stripped and cleated. These efforts reduced cotton losses from the value above to \$25,000 to \$40,000. Recently, this special work has been augmented by placing watchmen on platforms where 100 or more bales would remain on hand over night. The first year of this additional protection resulted in a fire loss of less than \$5,000, while handling in the neighborhood of 2,000,000 bales of cotton.

The fires reported as of unknown origin numbered 503, with a loss of \$298,000. What progress in fire prevention can be made without knowledge of the cause of fires? I believe that when an investigation is intelligently conducted, a positive origin, or at least a probable cause may be found. When we visit a fire, if the cause is not at first apparent, we may by a process of elimination, get down to a probable cause, and I believe it far better to do this than to report a fire "origin unknown."

#### RESULTS GAINED WITH SPARK ARRESTERS ON THE NORTH WESTERN.

H. T. Bentley, assistant superintendent of motive power and machinery, Chicago & North Western, gave a brief description of the Mudge-Slater box front end spark arrester, which has now been installed on 1,660 of the company's locomotives, all except the oil burners. This device, which was described in the *Railway Age Gazette* of November 1, 1912, page 846, had been invented by one of the company's master mechanics to overcome the difficulties encountered with the Master Mechanics' front end, which was so constructed that sparks could easily escape after the various parts had been warped by heat. After a test was made on November 25, 1910, all the company's locomotives operating in Wisconsin were equipped with the device, and since then it has been gradually applied to the others. During the year ending June 30, 1911, during which only a few of the locomotives were so equipped, the company paid \$129,205 for fire claims caused by sparks. In 1912 the amount had been reduced to \$63,707, and in 1913, to \$15,638.58. For two years the company has not had a fire caused by a locomotive in Wisconsin, and with the new device much less coal is required than before.

#### COL. DUNN'S ADDRESS.

Col. B. W. Dunn outlined briefly the history and work of the bureau for the safe transportation of explosives, and declared that the bureau and the new association could render each other a great deal of assistance by co-operating. He said the time has come in the history of railways when it is necessary to reduce every unnecessary expense, and to increase efficiency in every possible way. There is but one method left to curtail expenses, and that is to eliminate wastes. The movement for the safe transportation of explosives, and for the prevention of fires is the railways' answer to their critics among the public. The success of such movements depends on getting down to the detail causes and finding a remedy for them. In order to eliminate unnecessary losses it is necessary to first get accurate data to show what the losses are. Such data is now available in the case of losses caused by explosives, but are not so complete in a case of losses caused by acids and inflammables, and the membership of the Fire Protection Associa-

tion can render a great deal of assistance to the bureau by helping to obtain complete information to be reported to the bureau.

Anson Murphy, chief inspector, Alabama Great Southern, presented a brief paper on "Construction of Buildings," emphasizing the importance of considering fire protection in the construction and laying out of buildings.

A. D. Brooks, supervisor of fire protection, Illinois Central, presented a paper on "Spark Hazards," in which he stated that the greatest source of fire loss in connection with railway property is the company's buildings located within the range of the spark. Birds' nests, poorly shingled roofs, open joints or decayed parts which form pockets for catching the sparks present the worst conditions in such buildings. Quoting from a statement compiled from tests by Dr. W. F. M. Goss, in regard to the throwing of sparks along the right of way, he stated that the greatest number of sparks fell at from 30 to 150 ft. from the center of the track; that very few sparks fell from 15 to 20 ft. of the track, and that beyond 150 ft. from the center of the track sparks were of such character as to preclude any possibility of fire. However, sparks from fixed fires made on the right of way, when fanned by a strong wind may cause fires at a distance of several thousand feet.

Mr. Brooks stated that in his territory the fire losses for one year averaged \$27 per locomotive, or 0.003 cents per locomotive mile, making a total of \$83.50 per day. These losses include fires due to sparks from the ash pans, as well as the smoke stacks. Since the slide bottom ash pan has been installed these fires have increased approximately 50 per cent., due to the ash pans not being completely closed. To overcome this trouble the engineers are being held personally responsible for their proper adjustment. There were 52 fires from this cause, with approximate loss of \$117 per fire.

There were 61 fires caused by sparks from the smoke stack, having an average loss of \$400.12 per fire, or 10 per cent. of the exposed value. A comparison of four years' records shows a reduction of 45 per cent. in fires, and 39 per cent. in fire losses. In some cases it has been found necessary to treat the claimant with his own medicine. One instance was where an orchard had sustained a total loss for several years, due to fire being set by the locomotive. This was overcome on settling the claim by chopping down each tree when the claim had been settled, and the story goes that the loss was canceled after several trees were sacrificed. It was also pointed out that with better combustion in locomotives less sparks are likely to be emitted from the stack, and a coal burning to a low ash would be less liable to pass off sparks than one burning to clinkers.

P. Hevener, assistant supervisor of insurance fund, Rock Island Lines, presented a paper on "How Locomotives May Be Used to Extinguish Fires," in which he described the locomotive fire extinguisher made by the Nathan Manufacturing Company, and the arrangement that is used on the Rock Island Lines. The latter extinguisher was originated by one of the master mechanics on that line, and consists of a Y-fitting placed in the feed pipe on each side of the engine. Each engine so equipped is also provided with a 50-ft. length of 2-in. unlined linen fire hose with couplings and nozzles, which is kept in a box located underneath the running board. As all of the Rock Island engines are equipped with combined stop and check valves there is no special valve placed between the Y-fitting and the check valve for closing the connection to the boiler. The hose is coupled on to one leg of the Y, which is sealed when not in use by a cap having a finished seat bearing on the end of the fitting. When working as an extinguisher the water is injected into the hose instead of into the boiler, and while it is expected that this water will be rather warm, it is not hot enough to do any damage, and the nozzles may be easily handled with gloves. This device has been used with great success in the yards and terminals, and has saved several hundred thousands of dollars of fire damage. About 250 switch engines have been equipped with this device, which costs only \$45 per engine. In the larger yards and ter-

minals of the Rock Island the enginemen and trainmen are drilled to respond to alarms quickly, and periodical tests are made not only to insure that the device is in good working order, but to familiarize the yard employees with its use.

B. S. Mace, superintendent of insurance, Baltimore & Ohio, discussed the subject of "Fire Organization," reading the rules and regulations of the fire organization on his road.

The executive committee announced the appointment of four committees to report at the next annual meeting: Fire Hazards, Charles M. Rambo, chairman; Statistics and Forms, B. F. James, Colorado & Southern, chairman; Fire Fighting Organizations, E. B. Barry, Southern, chairman; Fire Fighting Apparatus, B. S. Mace, Baltimore & Ohio, chairman.

After the adjournment at noon on Wednesday the members witnessed a test made with the Pyrene fire extinguisher, manufactured by the Pyrene Manufacturing Company, New York, at the Twenty-seventh street roundhouse of the Illinois Central. A 330-lb. bale of cotton was burned for 1 hour and 10 minutes with hot coals, which burned a hole 6 in. wide by 26 in. deep. Three pints of Pyrene were used and 24 minutes later when the bale was opened the fire had been entirely extinguished.

### CONDITIONS OF COMPETITION FOR THE E. H. HARRIMAN MEMORIAL GOLD MEDAL.

As previously noted in the *Railway Age Gazette*, in order to create a better understanding on the part of the public as to what railways are doing to make safer conditions of travel and to safeguard their own personnel, through the prevention of accidents and the provision of the best methods of hygiene, Mrs. E. H. Harriman, about the first of the year, offered a gold medal to be awarded annually by the American Museum of Safety to the American steam railway making the best record of accident prevention and industrial hygiene affecting the public and its own personnel during each current year.

The gold medal is to be awarded to the railroad company itself, a replica in silver to the member of the operating department of that road who has done the most to bring this condition about, and a replica in bronze to the employee of the winning road who has been most conspicuous in the promotion of safety by suggestions or otherwise. The committee to award the medal appointed by the trustees of the American Museum of Safety has been changed since the original announcement, and is now constituted as follows:

Arthur Williams, President American Museum of Safety, Chairman; W. F. Allen, Secretary American Railway Association; Edgar E. Clarke, Chairman Interstate Commerce Commission; Samuel O. Dunn, Editor *Railway Age Gazette*; Charles P. Neill, Former United States Commissioner of Labor.

The first medal is to be awarded in January, 1914, for the year ending June 30, 1913. The award committee has recently formulated the conditions of competition and sent blank forms to the railway companies on which to make the returns on which the award will be based. These forms ask information as to the total locomotive miles run and the number of persons killed and injured, as well as the number killed and injured per million locomotive miles run, under the heads of Casualties in Train Accidents, and Casualties in Other Than Train Accidents, (excluding industrial accidents), for passengers, employees and other persons (not trespassing). Additional data is asked for industrial accidents (not involving the movement of engines or cars) to employees.

In formulating the conditions of competition the committee has decided on the following points, among others:

In making the award, consideration will be given to the system units under the jurisdiction of a single president.

Locomotive miles run is the total of all revenue and non-revenue mileage made by locomotives in all classes of service, except construction service.

Number of employees for computing rate per 1,000 in industrial accidents is determined by dividing the aggregate days worked by all employees in industrial service, such as trackmen, shopmen, freight handlers, and others not actually engaged in the operation of trains, by the number of working days in the period covered by the report.

Killed: Accidents to persons resulting in immediate death or in death within 24 hours from the time the accident occurred should be reported in column headed "Killed."

Injured: All other accidents to persons, including those resulting in death of the person injured after interval of more than 24 hours from the time the accident occurred, should be reported in the column headed "Injured." Accidents to employees should not be reported if they result in injuries so slight as not to prevent the employee injured from performing his accustomed service for more than three days, in the aggregate, during the ten days immediately following the accident. Injuries to passengers and other persons that do not prevent the injured person from following his customary vocation for more than one day should not be reported.

In order to assign varying weights to accidents, in view of the fact that the obligation of the carrier to the passenger is of a higher order than its obligation to the employee, the committee will employ the following factors by which the number of accidents per million locomotive miles will be multiplied in determining the relative standing:

Multiple to be applied to number of accidents per 1,000,000 locomotive miles and industrial accidents per 1,000 employees.

	Killed.	Injured.
Passengers in train accidents.....	200	4
Employees in train accidents.....	80	2
Other persons in train accidents.....	80	2
Passengers in other than train accidents.....	100	2
Employees in other than train accidents.....	40	1
Other persons in other than train accidents.....	40	1
Employees in industrial accidents.....	40	1

By adding the products of accidents per million locomotive miles run, a weighted scale will be obtained and, other things being equal, the carrier with the lowest record would show the highest measure of safety. However, other things would never be equal, and the weighted scale will be only one of the elements to be taken into consideration by the award committee. The committee will, with the assistance of the scale above referred to, consider the following:

(a) The aggregate traffic handled by a carrier measured in tons carried one mile and passengers carried one mile.

(b) The precautions that have been taken by the carrier to protect life and limb, such as:

1. Installation of block signals.
2. Interlocking plants.
3. Highway crossing gates, and signals.
4. High standard of maintenance of equipment and track.
5. Safety devices in shops.
6. Installation of hospitals, hospital cars and emergency hospitals to alleviate injuries and save life.
7. The institution of surprise tests to promote and check discipline.
8. The encouragement of safety committees amongst employees, and in fact every other item pertinent to securing the safety of life and limb as to which the management of a railroad owes the highest degree of care.

The award committee will also take into account all pertinent data, and those competing for the medals are asked to specify in considerable detail what information outside of the tabular statement of accidents they can furnish for the use of the committee. It is particularly desired that, under the head of general information, the committee should be informed as to the control of communicable diseases and the general sanitary measures for employees and for passengers. It is possible that the committee may in correspondence ask for additional data to assist in reaching a conclusion. Returns will cover the year ending June 30, 1913, and are to be in the hands of the chairman of the committee not later than November 1, 1913.

# B. & O. ENGINE TERMINAL AT CUMBERLAND, MD.

Construction of a Complete Mechanical Terminal Including  
a 31-Stall Roundhouse Designed for Mallet Locomotives.

The Baltimore & Ohio's engine terminal for the district lying west of Washington and Martinsburg is located at Cumberland, Md., which is at the foot of the eastern slope of the Allegheny mountains near the convergence of the lines from the west. Both passenger and freight traffic through this point is extremely heavy, and practically all of the locomotives used in this territory are of the Mallet and heavy Mikado types in freight service and the heaviest Pacific type in passenger service. The old engine terminal had become entirely inadequate to properly take care of the heavy locomotives, and this situation was rendered more acute by the extremely cold weather that prevails for relatively long periods. Sufficient ground space for a new terminal was available alongside the old facilities. The improvements which have been completed consist of a roundhouse with a 100-ft. turntable, a double cinder pit, a reinforced concrete coaling station, a sand house and a small power house, all

On account of the fact that the engines handled are principally Mallets, Mikados and large Pacifics, the engine pits are made 88 ft. long with side pit walls of sufficient width to provide bearing for jacking for a distance of 40 ft. on the inner ends of the pits. The pit walls are extended 12 ft. outside of the house to prevent track settlement. To facilitate handling repairs to Mallet engines, twin driving wheel drop pits are provided under four stalls, and truck wheel drop pits under two stalls. These pits are furnished with hydraulic pneumatic jacks of 30 tons and 15 tons capacities respectively. All pits are drained by a special sewer system which returns the water to a central reservoir from which it is taken for use in the boiler washing system. Each of the stalls is provided with a smoke jack made of Trammite supported on a wooden frame with hoods 4 ft. x 12 ft. long.

One-half of the floor wearing surface is of creosoted wooden blocks 3 in. deep, and one-half of mastic rock 1½ in. thick. Both types of floor are underlaid with 6 in. of concrete. The use of these two materials will give an effective test of their relative merits.

The building is heated by the indirect system, using one 200-in. fan and one 190-in. fan with capacity to completely change the air in the house about once in 15 minutes. One of these fans also supplies the air for heating the adjoining machine shop. These fans are located in separate rooms built as small additions to the engine house. The main air duct is of concrete encircling the house inside the outer wall with laterals of tile pipe leading to outlets alongside the wooden columns supporting the roof, there being three outlets in each stall. In addition to the outlets provided in the body of the building there are also two hot air outlets provided under the windows in each panel of the back wall. An exhaust main is run from the power house to the 190-in.

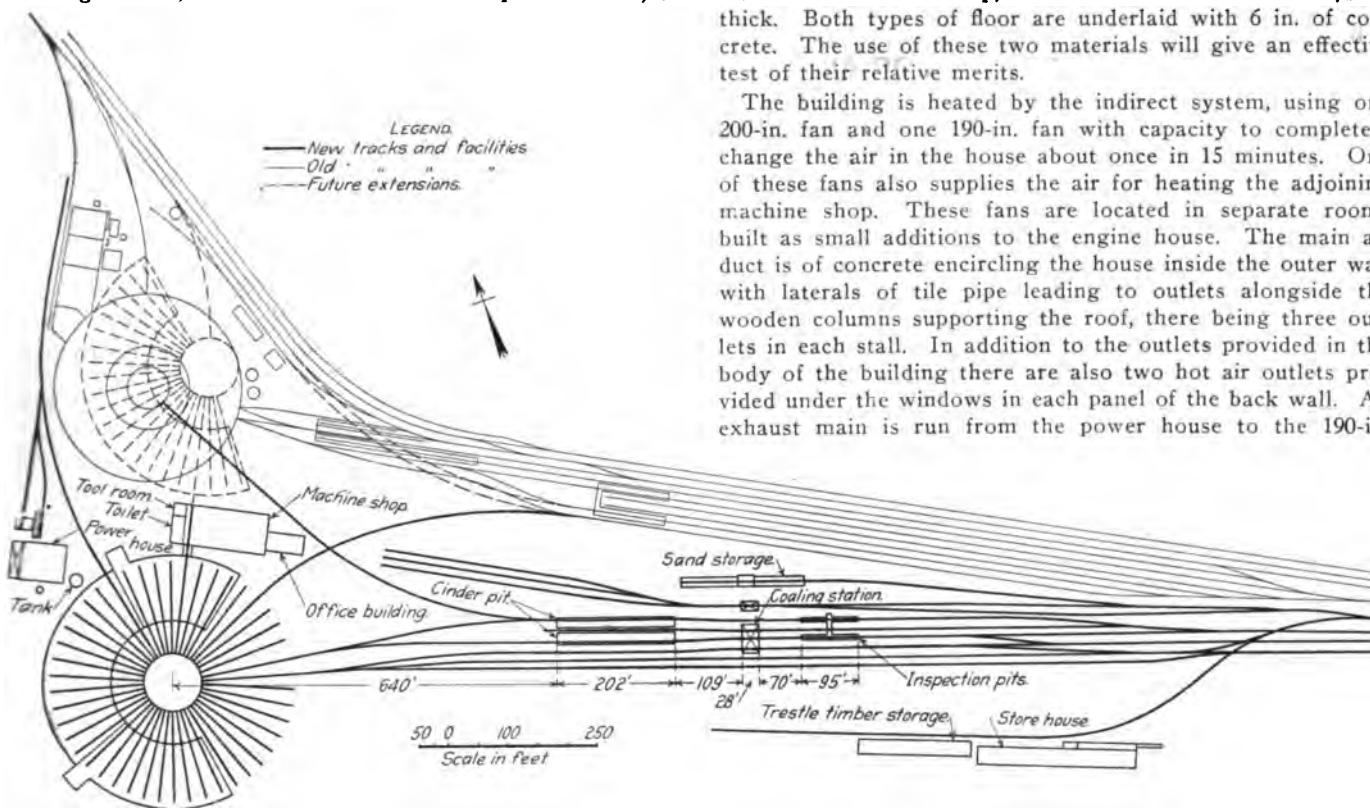

Plan of New B. & O. Engine Terminal at Cumberland, Md.

conveniently arranged and embodying an up-to-date locomotive terminal with buildings and other facilities of permanent construction.

In order to accommodate the large Mallet locomotives the length of the roundhouse was made 110 ft. There has been constructed at this time 31 stalls and space is left for further extension. A 100-ft. deck type turntable is used. The building has brick walls on concrete foundations, with timber roof posts and beams supporting a wooden roof. The rear wall of the house is made up of brick pilasters with broad window spaces between with top and bottom sash counterbalanced. The roof line is broken at the first row of posts near the front of the building so as to give a row of sash with narrow vertical louvre over each stall to provide light and ventilation. The locomotive door openings are fitted with wooden rolling doors of improved type which can be repaired at minimum cost when accidentally damaged.

fan so as to permit the use of such exhaust steam as may be available, but in the main, heat is supplied by live steam. All piping for the boiler washing system and for the steam, water and air service is brought from the power house through a short tunnel, but distribution in the house is overhead. The building is lighted by 60-watt Tungsten lamps. Five of these are placed in each stall.

Closely adjacent to the engine house and connected to it by a covered passageway, carrying a track connecting to one of the stalls of the roundhouse, is a machine shop 70 ft. x 140 ft. Machine tool equipment is installed for taking care of light running repairs including a driving wheel lathe. The machine tools are driven by electric motors. The shop is heated and lighted the same as the roundhouse.

At the west end of the shop in a separate room toilet facilities for the men are provided. At the east end of the machine shop and attached to it is a two-story office build-



ing about 33 x 64 ft. This is a brick building divided by lath and plaster partitions into rooms for the master mechanic, road foreman of engines, roundhouse foreman, storekeeper and clerks, also the engine despatchers' room with train board. This building is lighted by Tungsten lamps and heated by direct steam heat.

The power house building, located nearby, is about 67 ft. x 65 ft. and is divided by a longitudinal partition into a boiler

boilers are fitted with automatic stokers to which the coal is delivered by gravity from an overhead bunker. The coal is dumped into a hopper outside of the power house and is lifted with a bucket elevator onto a belt conveyor and discharged into the bunkers by means of an automatic tripper. Ashes are removed by hand.

The cinder pit is located between the coaling station and the engine house. This is a double pit of the submerged



- Rear View of Roundhouse.

room and an engine room. Current for power and lighting is furnished from an outside source. The engine room equipment consists of one 1,000-ft. air compressor, a large fire pump, three 50-kw. 2,200/440-volt transformers for power purposes, one 50-kw. and one 25-kw. series arc transformers for lighting purposes, and a six-panel switchboard. In the basement at one end of the engine room are located the boiler washing pumps. The boiler room equipment consists of two batteries of water tube boilers aggregating 1,000 h. p. The

type, having an overhead traveling crane with a grab bucket. The cinder pit stands practically full of water at all times. Into this the cinders are dumped and loaded by means of the grab bucket into cars standing on a track between the two ash pits. About 120 engines are handled over this pit daily. The economy of loading the cinders may be judged by the fact that one man working during the daylight hours only is able to load all the cinders.

The coaling station is located, as stated, in advance of the



Clinker Pit and Coaling Station.

cinder pit. The structure is of reinforced concrete with bunker capacity for 600 tons of coal. The bunker is divided into four bins to handle three sizes of coal; run-of-mine, crushed coal for locomotives equipped with stokers, and special coal for passenger locomotives. As the greatest consumption is run-of-mine coal two of the bins are used for storing this size. It is arranged to deliver coal to locomotives on four tracks passing beneath and along one end of the station. Run-of-mine coal can be taken on any one of these tracks, while on two tracks passenger coal can be taken and on another the stoker coal. The locomotive coal is received on a track passing one end of the station, the coal being dumped from the cars into a concrete pit and elevated by an inclined balanced skip hoist. The two skips are of 5 tons capacity each, and capable of elevating 125 tons of coal per hour. The electric motor operating the hoist is controlled automatically.

Provision is made for overhead storage of 20 cu. yds. of dry sand with suitable pipes for delivering it to the locomotives on any one of the four tracks. Green sand storage of about 1,200 cu. yds. is provided in a sand house near the coaling station. The sand is dried by steam driers and elevated into overhead storage bins by compressed air.

All buildings are completely encircled by a 6-in. fire line



Interior of Roundhouse.

supplying fourteen 4-in., two-way fire hydrants. An outfit of hose is stored in suitable hose houses in strategic locations. This system is supplied by the fire pump in the power house having a capacity of 700 gals. per minute on which steam is kept at all times. About 3,000 ft. of water pipe, varying in size from 10 in. to 14 in., was laid for supplying three penstocks. This was connected to existing water tanks and a 12-in. branch furnishes the power house with water.

This terminal was designed and constructed by Westinghouse, Church Kerr & Company, New York, under the direction of M. A. Long, assistant to chief engineer of the Baltimore & Ohio.

**THE ABANDONED ARGENTINE RAILWAY FUSION.**—The minister of public works in Argentina, discussing the decision of the Buenos Aires Great Southern Railway and the Buenos Aires Western Railway to withdraw their petition for amalgamation, said he considered that the matter was finished and would leave no evil effects. The government would always support private railways, and would maintain with these great companies the same excellent relations as in the past.

## AIR BRAKE HOSE.

By J. S. SHEAFE,

Engineer of Tests, Illinois Central, Chicago, Ill.

The general attention which has been given to the air brake hose question has resulted in a closer scrutiny of all failed hose. On every railroad almost daily reports are received of damage resulting from burst hose, and managers are asking the mechanical department, "Why?" Varying answers are given. The most popular explanation has been, poorer quality in air brake hose; other reasons are, higher train line pressure, imperfect workmanship, too little money paid to insure a good article, etc. From 30 cents a foot, minimum, to 65 cents a foot, maximum, is paid for air brake hose. The normal price now for a first class hose is approximately 40 cents a foot, so we may expect that in the first case the 30 cent man is using cheap material; the 65 cent man is using the best in the market and producing a hose which should give corresponding service. Here is the paradox; after exhaustive inspection and recording of the performance of thousands of air brake hose, it was found that the 30 cent hose had a better



In Reading the Present Hose Label a Man Occupies a Dangerous Position.

record than several higher priced ones and was well up in its performance; it was slightly above the general average of all the hose examined. The high priced hose did not give any considerable increase in service. A price of approximately 65 cents a foot is asked by the manufacturer because he is compelled to meet certain specifications. Whether or not such a hose is worth the difference is questionable, and a matter of opinion. There is no evidence at hand showing that it is worth more, from the standpoint of service, than the average priced hose.

The Master Car Builders' Association has adopted as standard a better air hose. The association was compelled to take this action because of the insistent demand of railroad managers. This hose, admittedly better, will cost over 60 cents a foot, an increase of 20 cents, or 50 per cent. over the present average price, and this amounts to an actual increase in air hose cost of \$730.00 per 1,000 cars. If the records previously mentioned fail to show any material advantage in buying 65 cent hose, and as

this expensive hose, of necessity, must be better than the cheapest, there is a gap in the investigations that can be explained only by one fact, that is, the railroads lose because they do not take proper care of the hose, and removal follows mechanical injury. In other words, air brake hose are made unfit for use before they have had an opportunity of rendering the service which they could give. It is hardly to be expected that a better hose will take care of this one most expensive item. If better hose are purchased and kept from all sorts of injury the railroads will receive greater service, not necessarily in the proportion rightfully looked for, but in an appreciable amount.

The best hose will have longer life, but when deterioration has set in, as it must, the hose will fail. With the better hose the failure is merely postponed so many months, but it is inevitable. If a certain brand of hose is known to be able to give so many months' service, it should be removed at the end of that time. The impracticability of car inspectors continually examining hose labels will at once be evident. One of the illustrations shows the dangerous position necessarily assumed by a man in order that he may read the present label showing the date of manufacture, and after he has read it he must calculate mentally whether or not the hose has reached the removal age.

One way to insure a hose being removed after a given time is to have figures vulcanized on the outside, and near the coupling end, to show the month and year in which a hose will have reached its allowable maximum age. The hose shown in the other illustration was made in August, 1913, and should not remain in



Hose So Labeled That the Removal Date May Be Read from Outside the Rails.

service after February, 1916, as shown by figures legible from outside the rails. A car inspector would remove this hose from service when the time had expired, and as he could easily tell this without any effort on his part, there would be no opportunity for the hose to remain on a car until so deteriorated that bursting under train line pressure would be inevitable.

Failure from mechanical injury may cut short the life before the hose has deteriorated to a sufficient extent to become dangerous. Only two things will minimize liability to accident with the better hose as now recommended: (1) Prevent failure from mechanical injury as much as possible; (2) Show on the hose, in legible figures, the date it should be removed on account of age.

## SMALL MOTOR-DRIVEN VENTILATING SETS FOR BUILDINGS.

When the Pennsylvania station at Pittsburgh was originally planned, it was equipped with what was at that time considered a thoroughly adequate ventilating system. The waiting rooms were furnished with fresh air by large motor-driven fans, and the offices were served by a system of ducts which communicated with the outside air, the natural draft being depended on for circulation. As the offices became more crowded, and especially as the officials began to realize the importance of an ample supply of fresh air in rendering employees comfortable and ef-



Arrangement of Motor Driven Ventilating Set at a Radiator.

ficient, it became evident that the natural draft was not sufficient and that some other arrangement must be made.

The problem was solved by installing in each office needing it, a small motor-driven ventilating set consisting of a Westinghouse motor and a Sirocco blower. As shown in the illustration, the set is placed on the floor near the radiator. It draws fresh air through the existing ducts and forces it out through the radiator, thus filling the room with fresh warm air. Current is obtained from the lighting circuit, and in some of the inside offices, the sets are used in summer as well as in winter. The set is not noisy, takes up very little room, and needs no attention beyond occasional lubrication. The sets are furnished in several different sizes to suit various conditions.

**TRANSPORTING COAL THROUGH PIPE LINES.**—A method of transporting coal by water pressure through a pipe has been suggested by E. G. Bell, engineer for the Hammersmith Electricity Works of London. By this method from 30 to 60 tons of coal per hour can, it is claimed, be forced through an 8-in. pipe leading from the Thames and under Chancellors' Road to the yard of the power plant on Fulham Palace Road, a distance of 600 yards.—*Coal Age*.

**BOILERS IN NEW ZEALAND.**—In New Zealand all steam boilers, other than on government railway locomotives, must be certified to be safe for work by the inspector of machinery department every year. In its annual report to parliament the department states that during the past year 7,011 boilers were examined, and that in 1,239 cases defects were discovered, of which 33 were very dangerous. The new boilers which were registered during the year numbered 587, with a total of 6,649 horse power.—*The Engineer*.

### NEW POWER REVERSE GEAR.

It is becoming generally recognized by railway men that locomotives in switching service, equipped with power reverse gear, can handle a much larger tonnage than those without, and as an adjunct to the efficiency and comfort of the crew such equipment cannot profitably be overlooked.

The Casey-Cavin reverse gear, which is a new power gear, has

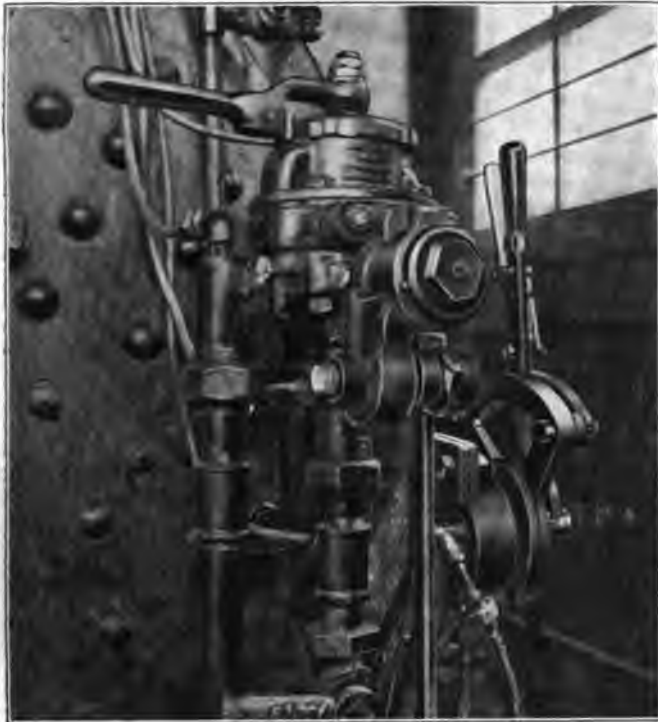

Arrangement of Lever and Valve in the Cab.

recently been introduced by the Canadian Locomotive Company, Ltd., Kingston, Ont., and patents are pending in several countries. The illustrations show the general arrangement and also the controlling valve and lever in the cab. This application was

made to some 0-6-0 type switching locomotives for the Canadian Northern.

The device consists essentially of a cylinder containing a piston, and rods so arranged as to shift the links or radius bars, and a valve containing two independently movable discs, one operated by the hand lever and the other by the connecting bar from the piston. These valve discs are so ported and arranged that on a movement of the hand controlled disc, pressure is admitted to one end of the cylinder and exhausted from the other end, thereby producing a movement of the piston which brings the ports in the other disc to the same relation that they originally bore to the hand controlled disc. After either a complete reversal or only a "hooking-up" of the motion, the pressure is held on both sides of the piston, thereby locking it at any point. From this it will be seen that should any excessive strain be set up in the reach rod, causing a movement of the piston, a compensating admission of pressure would take place on the opposite side of the piston. The point of cut-off is indicated by the position of the lever on the quadrant, corresponding to the hand type of lever, thereby guarding against confusion to inexperienced enginemen.

The cylinder is compact and can readily be attached to the boiler, firebox or running board in a substantial manner without interfering with other parts of the locomotive. The space occupied in the cab is very small, the travel of the handle being about 16 in.; the maximum pull necessary is from 12 to 15 lbs. The device is preferably operated by air pressure, but provision is made for the use of steam in the event of trouble with the air system. The total weight of the gear for a simple locomotive is about 375 lbs., and for a Mallet about 500 lbs.

Reports from applications made thus far are extremely satisfactory and seem to indicate that the device fills a long felt want, as it is reliable and at the same time so simple that it adds little or nothing to the cost of maintenance. A gear designed on similar lines and equipped with a positive mechanical locking device has also been developed by this company for fast passenger locomotives.

RAILWAY ACTIVITY IN NEW SOUTH WALES.—In New South Wales the most important works have consisted of the double tracking of several of the main lines leading into Sydney and the construction of the North Coast Railway, which will connect several important coastal towns with Sidney.

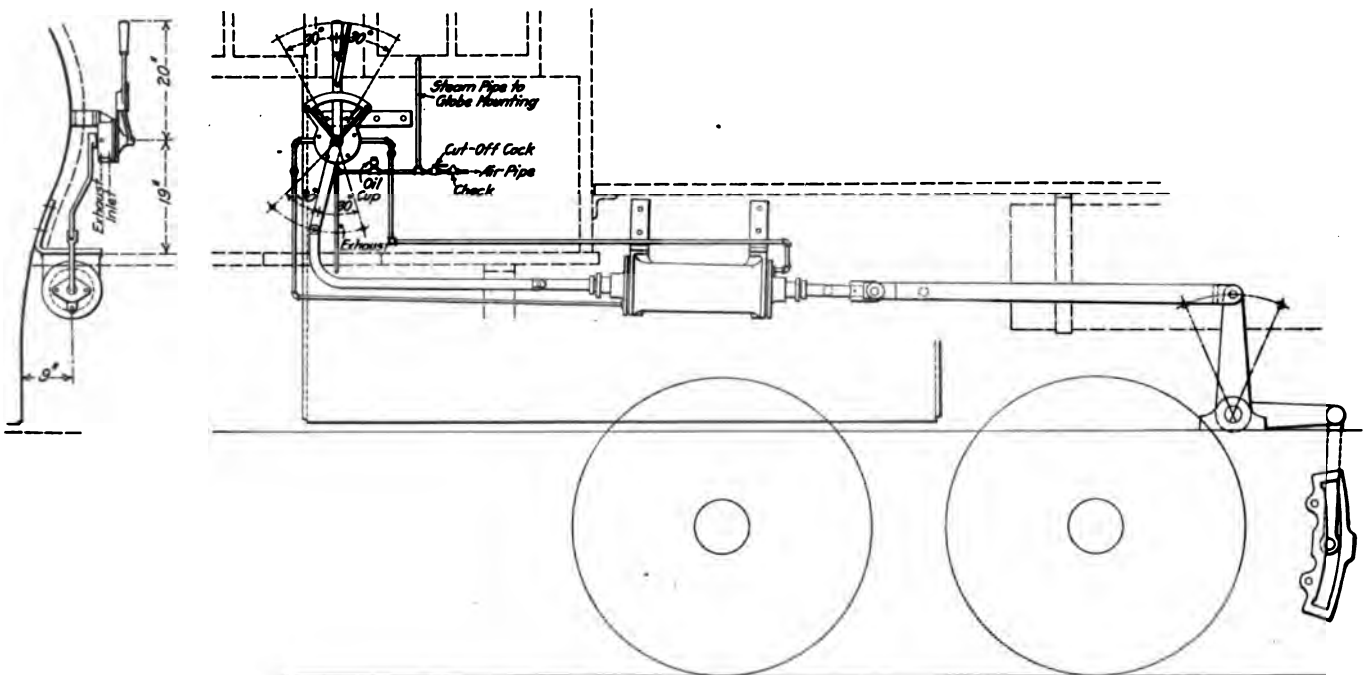

Application of Casey-Cavin Power Reverse Gear to a Canadian Northern Switching Locomotive.

## General News.

The Pennsylvania Railroad has appointed 35 committees of employees whose duty it will be to study the smaller matters which might involve accidents.

B. R. Pollock, general manager of the Boston & Maine, has issued a circular calling the attention of officers and employees to the importance of "Safety First."

The prominent railroad companies of Pennsylvania have taken action to co-operate with the state forestry department in efforts to prevent and extinguish forest fires.

Intoxicating liquors cannot be sold in railroad cars in the state of Ohio after November 4, the attorney general having advised the state authorities that the constitution forbids the maintenance of "moving saloons."

The Chicago, Milwaukee & St. Paul "Olympian" train was derailed near Forsythe, Mont., on October 8, while running at a high speed. Several of the steel cars were thrown down the embankment, but were not crushed and no one was seriously injured.

The ninth annual reunion of the Veteran Employees' Association of the Philadelphia division of the Pennsylvania Railroad was held at Lancaster, Pa., September 20, with about 800 persons present. Among those in attendance were C. A. Jeffries, a retired locomotive engineer, 92 years old, and his son, C. A. Jeffries, a conductor, who also is retired on a pension.

The general manager of the Pennsylvania has issued instructions to superintendents directing them to make sure that no railroad equipment involved in an accident causing loss of life or injuries to passengers shall be destroyed until public officials have had ample opportunity to examine it. This order is accompanied by an explanation that it is not intended to interfere with the promptest possible resumption of traffic.

Local ticket agents of the Baltimore & Ohio have been invited by the company to join in a contest in essay writing, on the subject of "How Should a Ticket Agent Handle an Undecided Inquiring Caller?" A prize of twenty-five dollars will be awarded for the best essay. All ticket agents and ticket clerks may compete. The essays must not be longer than three hundred words, and they are to be submitted to Oscar G. Murray, chairman of the board of directors of the company, who will award the prizes.

The Pennsylvania has issued new baggage rules. Railroad baggage or packages must be checked the same as regular baggage; and sample trunks, once emptied, must be shipped by express to their destination; they cannot be checked. The new order as to railroad supplies carried in baggage cars is the result of failure to put off packages at their proper destination. Traveling men have been selling their samples at the end of their trips and checking the empty trunks home. This has been stopped.

The Baltimore & Ohio reports that on Tuesday, October 7, a special train occupied by a party of baseball writers enroute from Chicago to New York to report the world's series, were carried at a record breaking speed. The special train, left Pittsburgh at 1:45 A. M. with Pacific type engine 2137, and ran to Cumberland, Md., 147 miles in 3 hours and 37 minutes, without a stop. Engine 2168 made the run thence to Baltimore, 190 miles, without a stop in 3 hours 55 minutes, an average of 48.7 miles an hour. Both of these runs were made without taking water, there being no track tanks on this section of the line.

A study of the economic cost of the smoke nuisance in Pittsburgh was undertaken in connection with the smoke investigation in March, 1912. The work was begun by Dr. C. W. A. Veditz. The Mellon Institute of Industrial Research & School of Specific Industry has just issued smoke investigation bulletin No. 4, prepared by John J. O'Connor, Jr., and dealing with this subject. Estimates are made of the cost of the smoke nuisance to the various types of industry in the community as well as the loss due to imperfect combustion; and there is included an itemized bill showing the partial cost to the people of Pittsburgh. The total of this bill is \$9,944,740.

In the list of nominees for offices to be filled at the annual election on January 21, 1914, the nominating committee of the American Society of Civil Engineers recommends for president Hunter McDonald, chief engineer, Nashville, Chattanooga & St. Louis, Nashville; for vice-presidents, Charles F. Loweth, chief engineer, Chicago, Milwaukee & St. Paul, Chicago, and Gardner S. Williams, consulting engineer, Ann Arbor, Mich; for treasurer, John F. Wallace, president, Westinghouse, Church Kerr & Company, New York. Six directors are nominated as follows: Richard Montford, consulting engineer, Louisville & Nashville; Arthur S. Tuttle, deputy chief engineer, New York City; George W. Fuller, consulting engineer, New York City; Charles H. Keefer, Ottawa, Ont.; Mortimer E. Cooley, University of Michigan, Ann Arbor, and E. E. Haskell, Cornell University, Ithaca, N. Y.

The Long Island Railroad has dismissed four crossing watchmen for inattention to duty and has had them prosecuted under the penal code of New York, section 1984. This section provides that any employee in train service, switch tender, or having charge of stations, starting, regulating or running trains, etc., who is intoxicated while on duty, or any employee in train service, switch tender, officer, agent, or employee who wilfully violates or omits his duty by which human life or safety is endangered, is guilty of a misdemeanor. The four cases which were prosecuted were, crossing watchman found under the influence of liquor on duty, who pleaded guilty and received a suspended sentence; crossing watchman found under the influence of liquor, who pleaded guilty and received a sentence of 30 days; crossing watchman found asleep, sent to the county jail for 60 days; crossing watchman found asleep, sentenced to the New York state penitentiary for 90 days.

E. P. Gutlious, general manager of the Intercolonial, has issued a circular which says in part: "Commencing on September 1, it is the intention to insist on a more rigid compliance with the rules and regulations which are made for the protection of the lives of the public and employees. All employees will start with a clean record beginning on this date and will receive credits for exceptional services. Where previously discipline was administered by suspensions, demerit marks will be placed against the record of the employee. For every repetition of an offense by an employee the demerit marks will be doubled. When demerit marks against employee number 60 his services will be dispensed with. For every 12 consecutive months of good service free from demerit marks an employee will have 20 demerit marks deducted from those that may stand against his record. Employees will be subject to summary dismissal for insubordination, drunkenness on or off duty, using intoxicating liquors when on duty, frequenting saloons or places of low repute, incompetency, dishonesty, and failing to carry out train rules respecting train movements."

### Arbitration Hearings Closed.

On October 10 the hearings on the demands of trainmen and conductors on the eastern roads for increases in pay were brought to a close, and on Wednesday of this week briefs were submitted by both sides following the summing up of Elisha Lee for the managers, and A. B. Garretson and W. G. Lee summing up for the employees.

### Ten Killed in an English Wreck.

On October 15 a local train into Liverpool, Eng., ran into the rear end of the Manchester express standing in the James street station, Liverpool, telescoping the rear coach and killing eight men and two women, and injuring a number of other passengers. The first accounts of the wreck say that the Manchester express stopped just outside of the station because of an engine failure and that apparently the engineman of the local ran past his signals.

### Unfilled Tonnage of the Steel Corporation.

The report of the United States Steel Corporation shows that the unfilled tonnage of the various subsidiary companies on September 30 amounted to 5,003,785 tons. This is a decrease of 219,683 tons as compared with the unfilled tonnage at the end of August. The unfilled orders on the books are now approximately

what they were on December 31, 1911, there having been a steady decline in unfilled tonnage since December 31, 1912, when the books showed 7,932,164 tons.

#### Details of Surprise Checking.

During the month of August the Pennsylvania Railroad made 185,000 efficiency tests and only 79 failures to observe the strict letter of the law were reported. In 1,852 cases tests were made of the observance of signals set at stop, and in all but one case there was perfect performance. Of 526 signals set at caution, all but three were duly obeyed. There were 1,321 tests of the observance by enginemen of flagmen's signals, and in not a single case was there failure to obey the rule perfectly. Flagmen were submitted to 5,989 tests, out of which there was perfect performance in all but 13 cases.

Conformity of enginemen to speed limit regulations was tested in 6,570 cases, with twenty-one failures. Observance of regulations as to handling explosives and inflammables was tested in 9,960 cases, with but two delinquents.

#### Grand Trunk Pacific.

Track laying on the main line of the Grand Trunk Pacific towards Prince Rupert has been completed to mile 1,200 west of Winnipeg, Man. At mile 1,190, where the railway for the second time crosses the Fraser river, track laying was held up for a short time until the steel bridge across the Fraser river was completed. The Fraser river is crossed for the third time about 40 miles west of the second crossing. Track laying will not be delayed at this crossing, as a temporary trestle is being erected, pending the completion of a steel bridge.

In the province of Saskatchewan 105 miles of branch line has just been opened for traffic on a part of the Biggar-Calgary branch. This line has been completed to Loverna, on the boundary line between Saskatchewan and Alberta, 105 miles from Biggar. Track laying on the Regina-Moose Jaw & North Westerly branch has just been completed to mile 91, a short distance beyond Mawer, Sask., 50 miles west of Moose Jaw, and within a few miles of the Saskatchewan river. Permission has been granted by the board of railway commissioners for the operation of this line, and as this is one of the greatest grain producing lines in the West, a very heavy traffic will move this season. On the Tofield-Calgary branch ballasting has been completed into Calgary, and first-class passenger service can be established as soon as terminals at Calgary are completed.

#### Dangers of the Railroad; A Different View.

Railroad travel in the United States is reasonably safe. A New York mathematician presents the safety proposition in a way that is unique and ought to be somewhat reassuring to timorous travelers:

"A typical journey for all roads in the country is now 34 miles, and there are taken on the average 2,275,122 such journeys in safety to each journey which results fatally. If a man were to ride out these 2,275,122 safe journeys at two per day for each business day in the year, it would take him 3,792 years. To have begun in time to meet his death in 1914 he would have had to start commuting in the year 1778 B. C., when Egypt was under the shepherd kings, and 458 years before Moses led the children of Israel through the Red Sea."

Railway mortality nowadays is mostly confined to railway employees and to persons not passengers. Many railway employees are careless and assume needless risks in the discharge of their duties. Thousands of trespassers on railroad tracks are killed every year, and in very few instances can this be charged to any fault in railroad management or operation.—*Louisville Courier-Journal*.

#### Department of Development.

A department of development has been created by the Ann Arbor and the Manistique & Lake Superior railroads with G. A. Weller, with office at Toledo, in charge. The object is to secure the greatest possible development of the territory served by the Ann Arbor and the Manistique & Lake Superior. Some of the things which will be undertaken are:

Development of new farm lands and increasing the productiveness of existing farms in every possible way.

Encouraging emigration into this territory to purchase and work all farm lands with view of securing their maximum productiveness.

Assistance in securing skilled instructors, material, etc., for agricultural and fruit-growing educational purposes.

Securing location of new factories and industries for this territory.

All possible assistance in increasing the productiveness and efficiency of existing factories and industries.

Assistance in securing co-operation of the state and federal authorities in the upbuilding of agricultural conditions, fruit culture, etc., in every possible way.

There is a large acreage of undeveloped land tributary to the lines of these companies which can be largely developed in agriculture and fruit-growing districts if it is properly handled.

#### New York Subways.

The New York Public Service Commission, First district, is asking for bids, to be opened November 10, for the construction of Section No. 3 of the Seventh avenue subway in the borough of Manhattan. The Seventh avenue subway is to be operated by the Interborough Rapid Transit Company, and Section No. 3 covers that portion of the route in Varick street and Seventh avenue extension between Beach street and Commerce street.

During the past week the commission has executed the contract awarded a short time ago to the Snare & Triest Company for the construction of section No. 1 of the elevated railroad in Queens. This contract embraces the junction station at the Queensboro bridge plaza, where the Astoria and Corona lines separate. The contract price for this section is \$880,000.

A public hearing was held recently by the commission on the two tunnel routes for the Brooklyn connections of the Interborough and New York Municipal systems in Manhattan. The commission has also ordered a public hearing for October 24 on the contract for the Livonia avenue extension of the Eastern Parkway subway, and for October 31 on the form of contract for the first section of the Eastern Parkway line. The Eastern Parkway route is to be operated by the Interborough Rapid Transit Company.

The reports of the engineers of the New York Public Service Commission for the First district, shows that there is now under contract \$83,000,000 worth of work on the new subway lines of the dual system of rapid transit, and an average daily force of 7,000 men are at work. Of this \$83,000,000, about \$38,000,000 is on lines to be operated by the Interborough Rapid Transit Company, and \$45,000,000 on the lines to be operated by the New York Municipal Railway Corporation. Of the latter, however, the Fourth avenue subway in the borough of Brooklyn, and the Centre street loop subway in the borough of Manhattan, costing together about \$28,000,000, are practically completed. It is estimated that the construction work on the city-owned lines will cost about \$200,000,000. There is, therefore about two-fifths of the value of this work already under contract. Of the remainder, to cost \$117,000,000, it is expected that more than one-half will be under contract before the end of the year, so that by that time, nine months after the signing of the dual system operating contracts, actual construction work will be in progress on three-quarters of the city-owned lines.

#### The Federal Valuation Board.

Charles A. Prouty is to retire as a member of the Interstate Commerce Commission to become director of physical valuation. The Interstate Commerce Commission announces that for the purpose of valuing railway property it has divided the country into five districts. Each to embrace approximately 50,000 miles of railroad. The title of each district, the headquarters city and the states included in each are as follows:

Eastern—Washington, D. C.; Connecticut, Delaware, District of Columbia, Maine, Maryland, Massachusetts, New Hampshire, New Jersey, New York, North Carolina, Pennsylvania, Rhode Island, Vermont, Virginia and West Virginia.

Southern—Chattanooga, Tenn.; Alabama, Florida, Georgia,

Indiana, Kentucky, Mississippi, Ohio, Panama, Porto Rico, South Carolina and Tennessee.

Central—Chicago, Arkansas, Illinois, Iowa, Louisiana, Michigan, Minnesota and Wisconsin.

Western—Kansas City; Colorado, Indian Territory, Kansas, Missouri, Nebraska, North Dakota, Oklahoma, South Dakota and Texas.

Pacific—San Francisco; Alaska, Arizona, California, Idaho, Montana, Nevada, New Mexico, Oregon, Utah, Washington and Wyoming.

Each valuation district will be under the direction of one of the members of the Valuation Board and will be in direct charge of one of the district engineers recently appointed. The Washington office will be in charge of Mr. Wendt; local engineer, Mr. Shea; Chattanooga, in charge of Mr. Jones, local engineer, Mr. Bayliss; Chicago, in charge of Mr. Pence, local engineer, Mr. Moore; Kansas City, Mr. Worley, local engineer, Mr. Witt; San Francisco, Mr. Thompson, local engineer, Mr. Pitman.

#### Revised Specifications for Valuation Maps.

The Interstate Commerce Commission has issued a second tentative draft of specifications for maps and profiles for use in connection with the valuation of railways. These specifications are modified in several important respects from the original draft issued August 1, as a result of the objections made by the committee of 15 engineers representing the railways, reviewed in the *Railway Age Gazette* of October 3, page 608.

The most important modification in the second draft is that permitting certain departures from the specifications regarding maps and profiles already made which comply in general with the rules laid down. No modification of the standards will be permitted on maps and profiles of extensions, improvements or changes; of existing railways where no such records now exist or where the present records are so incomplete as to require, in the judgment of the commission, new maps and profiles. The commission does not state at this time the extent to which present maps and profiles may be acceptable, as this can only be determined in the case of each individual carrier by an examination of its records. The commission, however, assures the railways of its purpose to demand only that amount of work to perfect existing maps and profiles as in its judgment is necessary to make them acceptable, but still insists that all maps and profiles for the permanent files of the commission shall be on standard size sheets and on cloth. To enable the commission to begin the valuation work promptly the railways are requested to furnish copies of existing maps and profiles and other standard and special plans.

With reference to showing the property lines and names of adjacent line owners, the original specifications are modified to require the railways to show the section and quarter section lines for a distance of one mile on each side of the railway only where such information is now in the possession of the railways.

These various modifications will decrease to a considerable extent, the work required of the railways, especially in the western states where the federal valuation work will be largely a duplication of that already done for various state commissions and these modifications should not in any way depreciate the value or the accuracy of the federal valuations.

#### A False Political Issue.

"We will (sic) be content only when we get the Grand Trunk line through from Canada to Boston," remarked Gov. Foss at the waterways dinner [in his campaign for another term as governor of Massachusetts]. It is questionable if Gov. Foss or any one else will be content even then. Still another railroad will have been added to the burden of those already existing, on which the public will be asked to enable dividends for the owners. The single-track highways to Canada will have been made two instead of one—and neither will be able to lay a double track because neither can afford the outlay. Eventually the exigencies of a ruinous competition will lead to a merger, and then Gov. Foss and those like him "will not be content" until they have gone through the same old course of things with

the Canadian Pacific! The marvel to us is how any person of full age, observing what has invariably happened in the case of previous railroad parallels, can advocate the building of still more parallels as a cure for the failure of previous ones. Nothing more supremely childish could well be conceived as an economic proposition. If only we could stop this everlasting notion that sometime a parallel railroad is going to insure competition and yet at the same time insure adequate service, even though such service cannot even pay its own keep, we might begin to do a little something sensible about forcing the railroads to serve the public as it ought to be served. The Grand Trunk, if built, would simply perpetuate the present grossly inadequate service, by making it even more nearly impossible, economically speaking to improve it than it is now.

Understand this: If you really want to improve a railroad service, the very last way to do it is to impoverish it by further subdividing an overworked field. The only sensible way is to do it by direct action. Stop looking at a railroad as if it were as private an enterprise as a woolen mill, and deal with it more as if it belonged to the public and were subject to public regulation. You might multiply Grand Trunks and C. P. R.'s until the cows come home, and in every successive case you would do nothing whatever but pile more and more railroad iron on the long-suffering camel's back to be carried at great cost by the very burden-bearer you most want to relieve.—*Lowell (Mass.) Courier.*

#### American Society of Civil Engineers.

At the informal meeting of the American Society of Civil Engineers, held on October 15, George A. Harwood, M. Am. Soc. C. E., chief engineer electric zone improvements, New York Central & Hudson River, gave an illustrated lecture on the Grand Central Terminal Work.

#### Roadmasters and Maintenance of Way Association.

The annual meeting of the executive committee of the Roadmasters and Maintenance of Way Association will be held at the Auditorium hotel, Chicago, at 11 a. m. on Saturday, October 25.

#### MEETINGS AND CONVENTIONS.

*The following list gives names of secretaries, dates of next or regular meetings, and places of meeting.*

- AIR BRAKE ASSOCIATION.—F. M. Nellis, 53 State St., Boston, Mass. Next convention, May, 1914.
- AMERICAN ASSOCIATION OF DEMURRAGE OFFICERS.—A. G. Thomason, Boston, Mass. Convention, May 19, 1914, St. Louis.
- AMERICAN ASSOCIATION OF GENERAL PASSENGER AND TICKET AGENTS.—W. C. Hope, New York. Annual meeting, October 14-15, Philadelphia, Pa.
- AMERICAN ASSOCIATION OF FREIGHT AGENTS.—R. O. Wells, East St. Louis, Ill. Next convention, April 21, Houston, Tex.
- AMERICAN ASSOCIATION OF RAILROAD SUPERINTENDENTS.—E. H. Harman, St. Louis, Mo.; 3d Thursday and Friday in May.
- AMERICAN ELECTRIC RAILWAY ASSOCIATION.—H. C. Donecker, 29 W. 39th St., New York. Next convention, October 13-17, Atlantic City, N. J.
- AMERICAN ELECTRIC RAILWAY MANUFACTURERS' ASSOC.—H. G. McConaughy, 165 Broadway, New York. Meetings with Am. Elec. Ry. Assoc.
- AMERICAN RAILWAY ASSOCIATION.—W. F. Allen, 75 Church St., New York. Next meeting, November 19, 1913, Chicago.
- AMERICAN RAILWAY BRIDGE AND BUILDING ASSOCIATION.—C. A. Lichty, C. & N. W., Chicago. Convention, October 21-24, 1913, Montreal.
- AMERICAN RAILWAY ENGINEERING ASSOCIATION.—E. H. Fritch, 900 S. Michigan Ave., Chicago. Next convention, March 17-20, Chicago.
- AMERICAN RAILWAY MASTER MECHANICS' ASSOCIATION.—J. W. Taylor, Old Colony building, Chicago.
- AMERICAN RAILWAY TOOL FOREMEN'S ASSOCIATION.—A. R. Davis, Central of Georgia, Macon, Ga.
- AMERICAN SOCIETY FOR TESTING MATERIALS.—Prof. E. Marburg, University of Pennsylvania, Philadelphia, Pa.
- AMERICAN SOCIETY OF CIVIL ENGINEERS.—C. W. Hunt, 220 W. 57th St., New York; 1st and 3d Wed., except June and August, New York.
- AMERICAN SOCIETY OF ENGINEERING CONTRACTORS.—J. R. Wenlinger, 11 Broadway, New York; 2d Tuesday of each month, New York.
- AMERICAN SOCIETY OF MECHANICAL ENGINEERS.—Calvin W. Rice, 29 W. 39th St., New York.
- AMERICAN WOOD PRESERVERS' ASSOCIATION.—F. J. Angier, B. & O., Baltimore, Md. Next convention, January 20-22, 1914, New Orleans, La.
- ASSOCIATION OF AMERICAN RAILWAY ACCOUNTING OFFICERS.—C. G. Phillips, 143 Dearborn St., Chicago. Annual meeting, May 28, Atlantic City, N. J.
- ASSOCIATION OF RAILWAY CLAIM AGENTS.—C. W. Egan, B. & O., Baltimore, Md. Next convention, May, 1914, St. Paul, Minn.
- ASSOCIATION OF RAILWAY ELECTRICAL ENGINEERS.—Jos. A. Andreucetti, C. & N. W. Ry., Chicago. Annual convention, October 18-24, Chicago.
- ASSOCIATION OF RAILWAY TELEGRAPH SUPERINTENDENTS.—P. W. Drew, 112 West Adams St., Chicago. Next convention, May 20-23, New Orleans, La.
- ASSOCIATION OF TRANSPORTATION AND CAR ACCOUNTING OFFICERS.—G. P. Conard, 75 Church St., New York. Next meeting, December 9-10, Galveston, Tex.
- ASSOCIATION OF WATER LINE ACCOUNTING OFFICERS.—W. R. Evans, Chamber of Commerce, Buffalo, N. Y.

# Traffic News.

**BRIDGE AND BUILDING SUPPLY MEN'S ASSOCIATION.**—H. A. Neally, Joseph Dixon Crucible Co., Jersey City, N. J. Meeting with American Railway Bridge and Building Association.

**CANADIAN RAILWAY CLUB.**—James Powell, Grand Trunk Ry., Montreal, Que.; 2d Tuesday in month, except June, July and Aug., Montreal.

**CANADIAN SOCIETY OF CIVIL ENGINEERS.**—Clement H. McLeod, 413 Dorchester St. Montreal, Que.; Thursday, Montreal.

**CAR FOREMEN'S ASSOCIATION OF CHICAGO.**—Aaron Kline, 841 North 50th Court, Chicago; 2d Monday in month, Chicago.

**CENTRAL RAILWAY CLUB.**—H. D. Vought, 95 Liberty St., New York; 2d Thurs. in Jan. and 2d Fri. in March, May, Sept., Nov., Buffalo, N. Y.

**CIVIL ENGINEERS' SOCIETY OF ST. PAUL.**—L. S. Pomeroy, Old State Capitol building, St. Paul, Minn.; 2d Monday, except June, July, August and September, St. Paul.

**ENGINEERS' SOCIETY OF PENNSYLVANIA.**—E. R. Dasher, Box 704, Harrisburg, Pa.; 1st Monday after second Saturday, Harrisburg, Pa.

**ENGINEERS' SOCIETY OF WESTERN PENNSYLVANIA.**—E. K. Hiles, Oliver building, Pittsburgh; 1st and 3d Tuesday, Pittsburgh, Pa.

**FREIGHT CLAIM ASSOCIATION.**—Warren P. Taylor, Richmond, Va. Next convention, May 20-22, Galveston, Tex.

**GENERAL SUPERINTENDENTS' ASSOCIATION OF CHICAGO.**—E. S. Koller, 226 W. Adams St., Chicago; Wed. preceding 3d Thurs., Chicago.

**INTERNATIONAL RAILWAY CONGRESS.**—Executive Committee, 11, rue de Louvain, Brussels, Belgium. Convention, 1915, Berlin.

**INTERNATIONAL RAILWAY FUEL ASSOCIATION.**—C. G. Hall, 922 McCormick building, Chicago. Annual convention, May 18-22, Chicago.

**INTERNATIONAL RAILWAY GENERAL FOREMEN'S ASSOCIATION.**—Wm. Hall, 829 West Broadway, Winona, Minn. Next convention, July, Chicago.

**INTERNATIONAL RAILROAD MASTER BLACKSMITHS' ASSOCIATION.**—A. L. Woodworth, Lima, Ohio. Next convention, third Tuesday in August.

**MAINTENANCE OF WAY & MASTER PAINTERS' ASSOCIATION OF THE UNITED STATES AND CANADA.**—W. G. Wilson, Lehigh Valley, Easton, Pa. Next convention, November 18-20, Louisville, Ky.

**MASTER BOILER MAKERS' ASSOCIATION.**—Harry D. Vought, 95 Liberty St., New York.

**MASTER CAR BUILDERS' ASSOCIATION.**—J. W. Taylor, Old Colony building, Chicago.

**MASTER CAR & LOCOMOTIVE PAINTERS' ASSOC. OF U. S. AND CANADA.**—A. P. Dane, B. & M., Reading, Mass.

**NATIONAL RAILWAY APPLIANCE ASSOC.**—Bruce V. Crandall, 537 So. Dearborn St., Chicago. Meetings with Am. Ry. Eng. Assoc.

**NEW ENGLAND RAILROAD CLUB.**—W. E. Cade, Jr., 683 Atlantic Ave., Boston, Mass.; 2d Tuesday in month, except June, July, Aug. and Sept., Boston.

**NEW YORK RAILROAD CLUB.**—H. D. Vought, 95 Liberty St., New York; 3rd Friday in month, except June, July and August, New York.

**NORTHERN RAILROAD CLUB.**—C. L. Kennedy, C., M. St. P., Duluth, Minn.; 4th Saturday, Duluth.

**PEORIA ASSOCIATION OF RAILROAD OFFICERS.**—M. W. Rotchford, Union Station, Peoria; 2d Thursday.

**RAILROAD CLUB OF KANSAS CITY.**—C. Manlove, 1008 Walnut St., Kansas City, Mo.; 3d Friday in month, Kansas City.

**RAILWAY BUSINESS ASSOCIATION.**—Frank W. Noxon, 2 Rector St., New York. Annual dinner, second week in December, 1913, New York.

**RAILWAY CLUB OF PITTSBURGH.**—J. B. Anderson, Penna. R. R., Pittsburgh, Pa.; 4th Friday in month, except June, July and August, Pittsburgh.

**RAILWAY ELECTRICAL SUPPLY MANUFACTURERS' ASSOC.**—J. Scribner, 1021 Monadnock Block, Chicago. Meetings with Assoc. Ry. Elec. Engrs.

**RAILWAY FIRE PROTECTION ASSOCIATION.**—C. B. Edwards, Mobile & Ohio, Mobile, Ala. Next meeting, October 7, Chicago.

**RAILWAY GARDENING ASSOCIATION.**—J. S. Butterfield, Lee's Summit, Mo.

**RAILWAY DEVELOPMENT ASSOCIATION.**—W. Nicholson, Kansas City Southern, Kansas City, Mo. Next meeting, November 11-12, Baltimore, Md.

**RAILWAY SIGNAL ASSOCIATION.**—C. E. Rosenberg, Bethlehem, Pa. Convention, October 14, Nashville, Tenn.

**RAILWAY STOREKEEPERS' ASSOCIATION.**—J. P. Murphy, Box C, Collinwood, Ohio.

**RAILWAY SUPPLY MANUFACTURERS' ASSOC.**—J. D. Conway, 2135 Oliver bldg., Pittsburgh, Pa. Meetings with M. M. and M. C. B. Assocs.

**RAILWAY TEL. & TEL. APPLIANCE ASSOC.**—W. E. Harkness, 284 Pearl St., New York. Meetings with Assoc. of Ry. Teleg. Sups.

**RICHMOND RAILROAD CLUB.**—F. O. Robinson, Richmond, Va.; 2d Monday except June, July and August.

**ROADMASTERS' AND MAINTENANCE OF WAY ASSOCIATION.**—L. C. Ryan, C. & N. W., Sterling, Ill.

**ST. LOUIS RAILWAY CLUB.**—B. W. Frauenthal, Union Station, St. Louis, Mo.; 2d Friday in month, except June, July and Aug., St. Louis.

**SIGNAL APPLIANCE ASSOCIATION.**—F. W. Edmonds, 3868 Park Ave., New York. Meeting with annual convention Railway Signal Association.

**SOCIETY OF RAILWAY FINANCIAL OFFICERS.**—C. Nyquist, La Salle St. Station, Chicago.

**SOUTHERN ASSOCIATION OF CAR SERVICE OFFICERS.**—E. W. Sandwich, A. & W. P. Ry., Montgomery, Ala. Annual meeting, October 16, 1913, Atlanta, Ga.

**SOUTHERN & SOUTHWESTERN RAILWAY CLUB.**—A. J. Merrill, Grant bldg., Atlanta, Ga.; 3d Thurs., Jan., March, May, July, Sept., Nov., Atlanta.

**TOLEDO TRANSPORTATION CLUB.**—J. G. Macomber, Woolson Spice Co., Toledo, Ohio; 1st Saturday, Toledo.

**TRACK SUPPLY ASSOCIATION.**—W. C. Kidd, Ramapo Iron Works, Hillsburn, N. Y. Meeting with Roadmasters' and Maintenance of Way Association.

**TRAFFIC CLUB OF CHICAGO.**—W. H. Wharton, La Salle Hotel, Chicago.

**TRAFFIC CLUB OF NEW YORK.**—C. A. Swope, 290 Broadway, New York; last Tuesday in month, except June, July and August, New York.

**TRAFFIC CLUB OF PITTSBURGH.**—D. L. Wells, Erie, Pittsburgh, Pa.; meetings monthly, Pittsburgh.

**TRAFFIC CLUB OF ST. LOUIS.**—A. F. Versen, Mercantile Library building, St. Louis, Mo. Annual meeting in November. Noonday meetings October to May.

**TRAIN DESPATCHERS' ASSOCIATION OF AMERICA.**—J. F. Mackie, 7122 Stewart Ave., Chicago. Next convention, June 16, Jacksonville, Fla.

**TRANSPORTATION CLUB OF BUFFALO.**—J. M. Sells, Buffalo; first Saturday after first Wednesday.

**TRANSPORTATION CLUB OF DETROIT.**—W. R. Hurley, L. S. & M. S., Detroit, Mich.; meetings monthly.

**TRAVELING ENGINEERS' ASSOCIATION.**—W. O. Thompson, N. Y. C. & H. R., East Buffalo, N. Y. Next meeting, Chicago.

**UTAH SOCIETY OF ENGINEERS.**—Fred D. Ulmer, Oregon Short Line, Salt Lake City, Utah; 3rd Friday of each month, except July and August.

**WESTERN CANADA RAILWAY CLUB.**—W. H. Rosevear, P. O. Box 1707, Winnipeg, Man.; 2d Monday, except June, July and August, Winnipeg.

**WESTERN RAILWAY CLUB.**—J. W. Taylor, Old Colony building, Chicago; 3d Tuesday of each month, except June, July and August.

**WESTERN SOCIETY OF ENGINEERS.**—J. H. Warder, 1735 Monadnock Block, Chicago; 1st Monday in month, except July and August, Chicago.

The Illinois Central and the Yazoo & Mississippi Valley, in co-operation with the Mississippi State Agricultural College, is preparing to run a "live stock and silo" special educational train.

The annual meeting of the National Industrial Traffic League will be held at the Hotel La Salle, Chicago, on November 13 and 14. The annual dinner will be held on the evening of November 13.

The Southern Pacific has announced that the usual one-way colonist rates to the Pacific coast will be effective next spring from March 15 to April 15, inclusive. Rates will be the same as those in effect for the fall colonist season, but the period will be 30 days instead of 15.

It is reported that the railways of Louisiana are considering the advisability of appealing to the courts to prevent the enforcement of an order issued by the Louisiana Railroad Commission requiring them to give passenger trains preference over freight trains.

The Central Passenger Association at its meeting in Chicago last week appointed a committee to report on the advisability of either abolishing special clergy fares, or establishing a uniform practice in regard to the granting of such rates. A committee was also appointed to consider the question of extension of tourist car facilities in the territory east of Chicago.

On October 15 a new fast freight line, to be known as the Baltimore Western Dispatch, was established for handling both baggage and carload freight between Baltimore and Cincinnati, Chicago, Louisville, St. Louis and points west and southwest; the Southern Railway, Chesapeake Steamship Company and the Chesapeake & Ohio having co-operated to form this new fast freight line.

The annual report of the Wells-Fargo Express Company presented at the annual meeting last week showed gross receipts from operation during the last fiscal year of \$34,934,814, as compared with \$32,465,970 for the preceding year. The length of the routes operated increased considerably; railroad 65,784 miles, increased 1,443; other routes 31,062 miles, increase 17,419 miles.

Various proposals have been brought before the Ontario government by county counsels looking to an increase in the taxes paid by railroad corporations in Ontario. In Ontario railroad taxes are on the basis of the value of land used by them in municipalities without any added increment for improvements or equipment, and in addition they pay to the province \$60 a mile for single track and \$40 a mile for each additional track, the maximum being \$100 a mile. This is claimed to be only about one-third of the rate that other tax payers are paying on land similarly situated.

## Canadian Ticket Agents' Association.

The convention of this association was held at Cleveland, Ohio, October 8, 9 and 10, with a large attendance. The members were entertained by a committee of Cleveland Passenger Agents. One of the principal subjects discussed was advertising, and J. Kidd, of Goderich, Ont., said that he distributed out-of-date folders among school children, thus stimulating the study of geography, and at the same time keeping the name of his road prominent. The president of the association for the ensuing year is George J. Alexander, Richmond, P. Q.; secretary, E. de la Hooke, London, Ont.

## The North Carolina Rate Situation.

The North Carolina house of representatives has accepted the railroads' offer of compromise on the proposed rate reduction legislation and the state senate is now considering the matter. The governor, in commenting on this matter in his message to the special session of the general assembly said: "In the original proposition there were conditions that made acceptance impossible. These have been eliminated and the proposition has



been amended to the decided advantage of the state. As it now stands, I believe that it makes a reduction reasonable under the present rate system. I know that it makes a substantial reduction. . . . The saving in freight rates will be a substantial gain, but the greater consideration is the opportunity for business that lower rates would offer. . . . The proposed reductions are, in my opinion, as much as or more than we could secure under the present system and construction of the law through the Interstate Commerce Commission even by long and expensive litigation. Under this proposition we would secure the benefits of the reduction with little expense and as soon as the rates could be put into effect."

**Car Surpluses and Shortages.**

Arthur Hale, chairman of the committee on relations between railroads, of the American Railway Association, in presenting

statistical bulletin No. 153, giving a summary of car surpluses and shortages by groups, from June 20, 1912, to October 1, 1913, says: The total surplus on October 1, 1913, was 41,994 cars; on September 15, 1913, 61,753 cars; and on September 26, 1912, 26,754 cars. Compared with the preceding period; there is a decrease in the total surplus of 19,759 cars, of which 16,311 is in box, 761 in coal, 3,116 in miscellaneous, and an increase of 429 in flat car surplus. The decrease in box car surplus is in groups 1 (New England Lines), 6 (Iowa, Illinois, Wisconsin and Minnesota), 8 (Kansas, Colorado, Oklahoma, Missouri and Arkansas), 10 (Washington, Oregon, Idaho, California, Nevada and Arizona), and 11 (Canadian Lines). The decrease in coal car surplus is in all groups, except 4 (the Virginias and Carolinas), 9 (Texas, Louisiana and New Mexico), and 10 (as above). The decrease in miscellaneous car surplus is in all groups, except 3 (Ohio, Indiana, Michigan and Western Pennsylvania), 4 (as above), 7 (Montana, Wyoming, Nebraska and

**CAR SURPLUSES AND SHORTAGES.**

Date	No. of roads.	Surpluses				Shortages					
		Box.	Flat.	Coal, gondola and hopper.	Other kinds.	Total.	Box.	Flat.	Coal, gondola and hopper.	Other kinds.	Total.
Group *1.—October 1, 1913.....	7	0	0	0	127	1,283	113	100	35	1,531	
" 2.—" 1, 1913.....	33	389	49	748	232	1,500	1	950	36	2,487	
" 3.—" 1, 1913.....	29	340	29	300	751	1,982	180	2,103	381	4,646	
" 4.—" 1, 1913.....	14	3,462	398	859	554	5,273	3,840	361	4,573	9,354	
" 5.—" 1, 1913.....	24	0	0	265	201	1,214	164	628	115	2,121	
" 6.—" 1, 1913.....	33	2,120	197	1,064	2,697	2,368	247	857	147	3,619	
" 7.—" 1, 1913.....	3	61	18	544	430	1,053	163	0	32	195	
" 8.—" 1, 1913.....	19	3,080	426	1,451	2,260	7,217	221	8	216	622	
" 9.—" 1, 1913.....	15	3,202	819	476	685	5,182	107	0	4	25	
" 10.—" 1, 1913.....	21	2,729	917	2,226	6,313	12,185	1,010	288	70	1,666	
" 11.—" 1, 1913.....	6	704	311	20	540	1,575	3,590	595	892	5,243	
<b>Total</b> .....	<b>204</b>	<b>16,087</b>	<b>3,164</b>	<b>7,953</b>	<b>14,790</b>	<b>41,994</b>	<b>17,278</b>	<b>1,957</b>	<b>10,393</b>	<b>1,992</b>	<b>31,620</b>

\*Group 1 is composed of New England lines; Group 2—New York, New Jersey, Delaware, Maryland and Eastern Pennsylvania lines; Group 3—Ohio, Indiana, Michigan and Western Pennsylvania lines; Group 4—West Virginia, Virginia, North and South Carolina lines; Group 5—Kentucky, Tennessee, Mississippi, Alabama, Georgia and Florida lines; Group 6—Iowa, Illinois, Wisconsin and Minnesota lines; Group 7—Montana, Wyoming, Nebraska, North Dakota and South Dakota lines; Group 8—Kansas, Colorado, Missouri, Arkansas and Oklahoma lines; Group 9—Texas, Louisiana and New Mexico lines; Group 10—Washington, Oregon, Idaho, California, Nevada and Arizona lines; Group 11—Canadian lines.

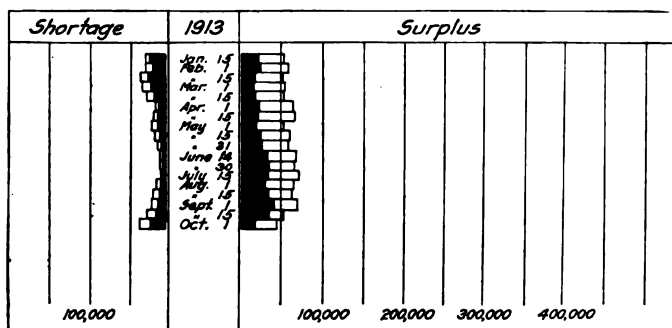
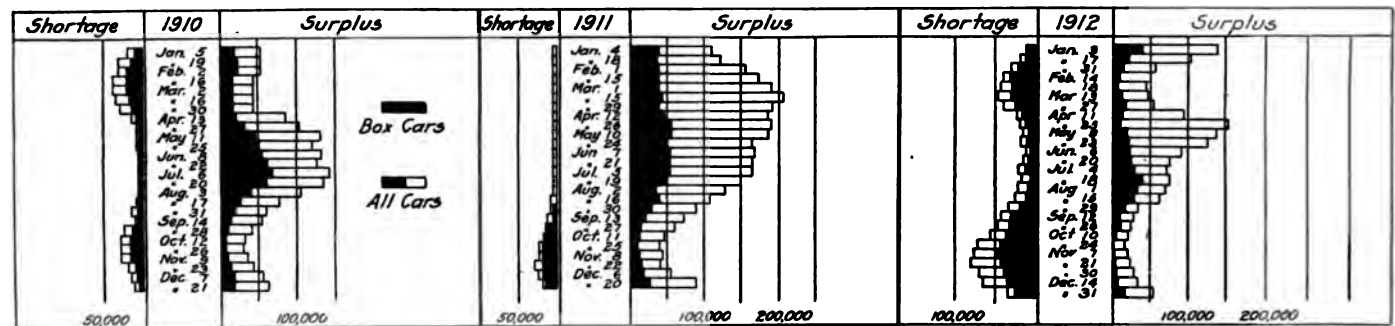
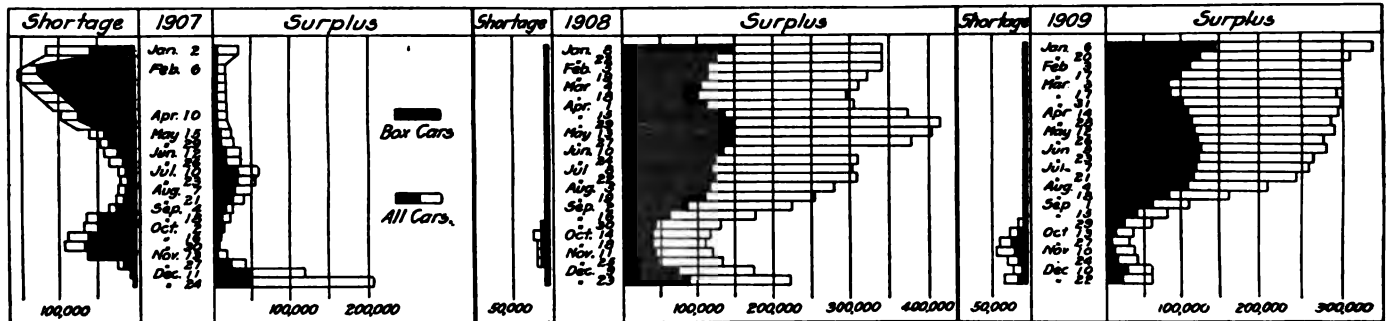

**Car Surpluses and Shortages, 1907 to 1913.**

the Dakotas), and 9 (as above). The increase in flat car surplus is in groups 4, 8, 9, 10 and 11 (as above).

The total shortage on October 1, 1913, was 31,620 cars; on September 15, 1913, 21,594 cars; and on September 26, 1912, 44,547 cars. Compared with the preceding period; there is an increase in the total shortage of 10,026 cars, of which 6,206 is in box, 534 in flat, 2,662 in coal and 624 in miscellaneous car shortage. The increase in box car shortage is in all groups, except 3 (as above), 5 (Kentucky, Tennessee, Mississippi, Alabama, Georgia and Florida), and 8 (as above). The increase in flat car shortage is in groups 2 (New York, New Jersey, Delaware, Maryland and Eastern Pennsylvania), 3, 6, 8, 10 and 11 (as above). The increase in coal car shortage is in all groups, except 5 and 6 (as above). The increase in miscellaneous car shortage is in all groups, except 7 (as above).

Compared with the corresponding period of 1912; there is an increase in the total surplus of 15,240 cars, of which 7,736 is in box, 1,800 in flat, 1,759 in coal and 3,945 in miscellaneous car surplus. There is a decrease in the total shortage of 12,927 cars, of which 10,016 is in box, 1,612 in flat, 1,318 in coal, and an increase of 19 in miscellaneous car shortage.

The accompanying table gives car surplus and shortage figures by groups for the last period covered in the report and the diagram shows total bi-weekly surpluses and shortage from 1907 to 1913.

**General Crop Conditions.**

The Department of Agriculture estimates crop conditions to be as follows:

Crops.	FOR THE UNITED STATES.					
	Condition Oct. 1, or at time of harvest.			Acreage, 1913.		
	1913.	1912.	10-yr. av.	1913.	P. ct. of 1912.	Acres.
Corn	55.3	82.2	80.6	65.1	99.8	106,884,000
Buckwheat	65.9	89.2	84.2	75.4	100.0	841,000
Potatoes	67.7	85.1	76.4	69.9	99.3	3,685,000
Tobacco	76.6	81.8	83.1	74.5	93.4	1,144,500
Flax	74.7	83.8	78.5	74.9	85.1	2,425,000
Rice	80.3	89.2	87.5	88.0	114.0	824,100
Apples	46.6	67.8	54.1	47.7	....	....

The yields indicated by the condition of crops on October 1, 1913, or at time of harvest, and the final yields in preceding years, for comparison, follow:

Crops.	Yield per acre.			Total production in millions of bushels.			Increase (+) or decrease (-) in production during September. Per cent.
	1913a.	1912.	1908-12	1913a.	1912.	1911.	
	Bus.	Final. Bus.	ave. Bus.	Final.	Final.	Final.	
Corn	22.2	29.2	26.5	2,373	3,125	2,531	+0.9
Buckwheat	16.5	22.9	21.0	14	19	18	-6.7
White potatoes	86.7	113.4	96.1	319	421	293	-1.8
Tobacco, lbs.	766.0	785.3	822.3	877	963	905	+1.9
Flax	8.7	9.8	8.2	21	28	19	+5.0
Rice	30.9	34.7	33.7	25	25	23	-7.4

a Interpreted from condition reports.

Preliminary estimates of production have been made as follows:

Crops.	Yield per acre.			Production (000 omitted).		
	1913.	1912.	1908-12	1913.	1912.	1911.
	Bus.	Final. Bus.	ave. Bus.	Final.	Final.	Final.
Spring wheat	13.0	17.2	13.3	242,714	330,348	190,682
Winter wheat	16.5	15.1	15.2	510,519	399,919	430,656
All wheat	15.2	15.9	14.6	753,233	730,267	621,338
Oats	29.3	37.4	29.7	1,122,139	1,418,337	922,298
Barley	23.9	29.7	24.5	173,301	223,824	160,240
Rye	16.3	16.8	16.2	34,789	35,664	33,119
Hay, tame	1.31	1.47	1.38	63,460	72,691	54,916

The quality of spring wheat is 92.0 per cent., as compared with a ten-year average of 86.9; oats, 89.1 per cent., compared with a ten-year average of 87.1; barley, 86.4 per cent., compared with a ten-year average of 87.0.

Details for important states follow:

States.	OATS.					
	Production.			Quality.		
	Per acre.		Total (000 omitted).	1913.		1912.
	1913.	1912.	1913.	1912.	1913.	1912.
	Bus.	Bus.	Bus.	Bus.	P. ct.	P. ct.
Iowa	34.5	44.2	168,326	217,818	94	95
Illinois	23.8	43.3	102,435	182,726	78	91
Minnesota	37.8	41.7	112,531	122,932	93	94
Wisconsin	36.5	37.3	83,768	84,746	95	87
Nebraska	26.5	24.4	60,288	55,510	89	89
North Dakota	25.7	41.4	57,928	95,220	89	95
Kansas	19.5	32.0	36,894	55,040	80	91
Ohio	30.2	44.0	55,055	93,280	89	90
Indiana	21.4	40.1	37,471	79,799	77	90
South Dakota	26.5	33.8	42,294	52,390	88	91
Michigan	30.0	34.9	45,450	51,826	91	82
New York	33.5	30.8	43,114	36,714	94	83
Missouri	21.2	33.0	26,246	37,125	78	94
Pennsylvania	31.0	33.1	35,774	36,377	90	88
United States	29.3	37.4	1,122,139	1,418,337	89.1	91.0

States.	SPRING WHEAT.					
	Production.			Quality.		
	Per acre.		Total (000 omitted).	1913.		1912.
	1913.	1912.	1913.	1912.	1913.	1912.
	Bus.	Bus.	Bus.	Bus.	P. ct.	P. ct.
North Dakota	10.5	18.0	79,695	143,820	93	89
Minnesota	16.2	15.5	67,959	67,038	92	86
South Dakota	9.0	14.2	33,075	52,185	91	88
Washington	19.0	20.4	23,161	26,459	90	91
United States	13.0	17.2	242,714	330,348	92.0	88.7

**CORN.**

States	Per cent. of U. S. acreage in States.	Condition October 1.			Condition Sept. 1, 1913.
		1913.	1912.	10-yr. av.	
Illinois	9.9	61	86	84	62
Iowa	9.3	77	91	82	76
Nebraska	7.1	39	77	78	37
Kansas	6.9	10	72	69	10
Missouri	6.9	44	84	80	41
Texas	6.6	78	75	73	78
Oklahoma	4.8	38	63	67	39
Indiana	4.6	80	89	85	81
Georgia	3.8	87	74	86	87
Ohio	3.7	80	90	84	81
Kentucky	3.4	60	89	86	59
Tennessee	3.1	66	82	85	65
Alabama	3.0	78	80	86	78
Mississippi	3.0	81	80	86	81
North Carolina	2.6	85	75	84	87
South Dakota	2.5	79	84	84	78
Arkansas	2.3	70	78	80	71
Minnesota	2.2	99	84	83	95
South Carolina	1.9	85	75	82	86
Virginia	1.9	85	73	85	85
Louisiana	1.8	84	80	82	85
Michigan	1.5	80	82	82	80
Wisconsin	1.5	94	83	84	94
Pennsylvania	1.4	78	85	84	81
United States	100.0	65.3	82.2	80.6	65.1

**INTERSTATE COMMERCE COMMISSION.**

For item regarding the Valuation Board see General News section.

The commission has suspended from October 21 until April 21 supplement to the tariff of the Alabama Great Southern that would advance the rates for the transportation of lumber and shingles, C. L., from local points on the Alabama Great Southern in Alabama and Georgia to Chattanooga, Tenn.

The commission has suspended from October 11 until February 8 certain schedules contained in the tariff of the Louisville & Nashville, which proposed to reduce by from 5 to 25 cents per ton, rates on coal, from mines on the Louisville & Nashville in Virginia located west of Middleborough, Va., to points north of the Ohio river. The Black Mountain Coal Company et al., operating mines located east of Middleborough in the St. Charles district, claim that the proposed reduction is a discrimination against their mines, in that a similar readjustment is not made in rates from mines east of Middleborough. The present rates from mines in the St. Charles district are the same as rates from mines in the Middleborough-Jellico district.

**STATE COMMISSIONS.**

The State Corporation Commission of New Mexico recently held an informal conference with the traffic and operating officials of the various express companies operating in the state, for the purpose of considering a general reduction of express rates. As a result of this conference the commission announces that local express rates will be reduced voluntarily by the companies by amounts ranging from 25 to 60 per cent., the reductions to become effective within 60 to 90 days. The reductions will, in general, correspond with the reductions recently ordered by the Interstate Commerce Commission in interstate rates.

**COURT NEWS.**

Judge Farrington, of the United States district court at Carson City, Nev., has rendered a decision enjoining the Nevada State Railroad Commission from putting into effect an order issued last January reducing main and branch line passenger fares in the state from five and four cents to three cents per mile.

Fines of \$1,000 each have been assessed by the federal district court at Pueblo, Col., against the Denver & Rio Grande and Colorado & Southern railways, and the Victor American Fuel Company, Colorado Fuel & Iron Company, United States Portland Cement Company, Colorado Portland Cement Company and Great Western Sugar Company, for giving and receiving passes for travel in the state. The fines were assessed under indictments returned over a year ago on the ground that the giving of state passes to interstate shippers was a violation of the Elkins act. The companies filed pleas submitting to the judgment of the court.

REVENUES AND EXPENSES OF RAILWAYS.

MONTH OF JULY, 1913.

Table with columns: Name of road, Average mileage operated during period, Operating revenues (Freight, Passenger, Total, inc. misc.), Maintenance of Way and structures, equipment, Operating expenses (Traffic, Transportation, General), Total, Net operating revenue (or deficit), Outside operations, net, Taxes, Operating income (or loss), Increase (or decr.) comp. with last year.

MONTH OF AUGUST, 1913.

Table with columns: Name of road, Average mileage operated during period, Operating revenues (Freight, Passenger, Total, inc. misc.), Maintenance of Way and structures, equipment, Operating expenses (Traffic, Transportation, General), Total, Net operating revenue (or deficit), Outside operations, net, Taxes, Operating income (or loss), Increase (or decr.) comp. with last year.

TWO MONTHS OF FISCAL YEAR, 1914.

Table with columns: Name of road, Average mileage operated during period, Operating revenues (Freight, Passenger, Total, inc. misc.), Maintenance of Way and structures, equipment, Operating expenses (Traffic, Transportation, General), Total, Net operating revenue (or deficit), Outside operations, net, Taxes, Operating income (or loss), Increase (or decr.) comp. with last year.

REVENUES AND EXPENSES OF RAILWAYS.

TWO MONTHS OF FISCAL YEAR, 1914—CONTINUED.

Table with columns: Name of road, Average mileage operated during period, Operating revenues (Freight, Passenger, Total), Operating expenses (Traffic, Transportation, General, Total), Net operating revenue, Outside operations, Taxes, Operating income, Increase (or decrease) comp. with last year.

## Railway Officers.

### Executive, Financial and Legal Officers.

W. H. Vincent has been appointed assistant auditor of the Georgia Railroad, with office at Augusta, Ga.

E. A. Chavannes is appointed auditor of the Pacific & Idaho Northern Railway and the Central Idaho Telegraph & Telephone Company, with office at New Meadows, Adams County, Idaho, succeeding W. R. Mozier, resigned.

Edmund Deschenes, Jr., whose appointment as auditor of the Central Vermont, with headquarters at St. Albans, Vt., has been announced in these columns, was born on September 7, 1878, at St. Albans, and was educated in the grammar schools of his native town. He began railway work in March, 1893, as a messenger on the Central Vermont, and subsequently was clerk in charge of freight accounts, traveling auditor, chief clerk of passenger accounts, chief clerk to auditor, and now becomes auditor as above noted.

William Hough, first assistant auditor of the Pullman Company at Chicago, has been appointed general auditor, succeeding F. C. N. Robertson, deceased, and Frederick L. Simmons, second assistant auditor, at Chicago, has been appointed assistant general auditor. E. C. Morris, statistician, has been appointed auditor of the manufacturing department. George S. Seymour, third assistant auditor, has been appointed auditor of miscellaneous accounts, and Wm. Riley, ticket auditor, has been appointed auditor of ticket accounts.

William J. Cunningham, whose appointment as vice-president's assistant of the New York, New Haven & Hartford was announced in our issue of last week, was born April 29, 1875, at



W. J. Cunningham.

St. John, N. B. He began railway work in 1892 with the Canadian Pacific as stenographer and ticket clerk in the passenger department at St. John, N. B., and Boston, Mass. In 1896 he went to the Boston & Albany as clerk in the superintendent's office at Boston, and three years later became statistical clerk to the general manager of the New York, New Haven & Hartford. From 1901 to 1907 he was employed in various capacities by the Delaware, Lackawanna & Western, his last position being assistant chief clerk to the general superintendent. In November, 1907, he became associated with J. H. Hustis (then assistant general manager of the Boston & Albany) as statistician. When the Harvard Business School was established in 1908 Mr. Cunningham was engaged for two years as lecturer on railroad operation. In September, 1910, he was appointed assistant professor of transportation, but continued to act on Mr. Hustis' staff as consulting statistician. Coincident with the election of Mr. Hustis as vice-president of the New York, New Haven & Hartford, Prof. Cunningham was appointed vice-president's assistant, with headquarters at New Haven, Conn., as above noted. His title will be changed to president's assistant when the by-laws of the company are changed on October 22 and Mr. Hustis becomes president. To permit of the acceptance of this appointment for two years Harvard University has granted partial leave of absence for that time, and Prof. Cunningham will continue to lecture at Harvard on one day per week. During the summer of 1910 Prof. Cunningham made a special study of British railways, and the following summer did work of a similar nature on the Harriman Lines with special reference to the Unit system, and

also on the Santa Fe and the Frisco lines. In the summer of 1912 he made a study of the Prussian-Hessian railways, and during the past summer he was engaged on special work for Vice-President Seger of the Union Pacific system.

Louis Judson Hensley, whose appointment as auditor of the Kansas City Southern, with headquarters at Kansas City, Mo.,



L. J. Hensley.

has already been announced in these columns, was born October 14, 1879, at Buckner, Mo. He was educated in the public schools of Independence, Mo., and began railway work January 22, 1903, with the Kansas City Southern as assistant bill clerk in the auditor's office. He has remained with that company continuously, the first six years occupying successively the positions of bookkeeper, traveling material clerk and voucher. He was then on December 1, 1908, made chief clerk to the vice-president and auditor, and on February 1, 1912, he became assistant auditor. Mr. Hensley's promotion to the position of auditor was effective September 1 of this year.

James G. Woodworth, who has been elected vice-president in charge of traffic of the Northern Pacific, with headquarters at St. Paul, Minn., was born October 31, 1864, at Hillsdale, Mich. He began railway work in 1879 as an office boy in the general freight department of the Chicago & North Western, and from May, 1880, to March, 1883, was telegraph operator and station agent at De Smet, S. Dak. He then became chief clerk in the general agent's office of the Chicago, St. Paul, Minneapolis & Omaha at Minneapolis, Minn., and in September of the following year went to the Union Pacific as freight solicitor at Portland, Ore. From January, 1886, to September, 1888, he was successively traveling freight agent and chief clerk in the general freight department of the Oregon Rail-



J. G. Woodworth.

way & Navigation Company. He was then made assistant general freight agent of that company, and in December, 1889, was appointed to a similar position on the Union Pacific, with headquarters at Portland. He was advanced to general freight agent of the Pacific division in July of the following year, and eight months later became assistant general western freight agent at Portland, being transferred to Omaha, Neb., in November, 1892, as assistant general freight agent. Mr. Woodworth left the Union Pacific in July, 1893, and for one year was general freight agent of the Iowa Central. He returned to the Oregon Railway & Navigation Company as assistant to the receiver and general manager in July, 1894, and two years later became assistant to the president of that company. He was afterwards general freight agent from October, 1897, to October, 1899, when he became traffic manager of the Pacific Coast Company. He left the latter company to accept the position of assistant to the first

vice-president of the Chicago, Burlington & Quincy in January, 1902, where he remained for three years, resigning to become traffic manager of the Northern Pacific. He held the latter office at the time of his recent election to the vice-presidency, as above noted.

Clement William Nelson, assistant general manager of the St. Louis Southwestern, has been appointed assistant to the president with headquarters at St. Louis, Mo., and the former position has been abolished, effective October 7.



C. W. Nelson.

Mr. Nelson was born July 12, 1870, at Morristown, Ill., and received a public school education, 1878 to 1889. He began railway work in June, 1889, with the American Express Company (Great Northern Railway). From September, 1890, to September, 1896, he was clerk and timekeeper in various departments of the Great Northern, and then until June, 1899, was chief clerk to superintendent on various divisions. Mr. Nelson went to the St. Louis Southwestern in July, 1899, as

chief clerk to the general superintendent, and in March of the following year was promoted to chief clerk to the vice-president and general manager. He was made assistant general manager in May, 1906, which position he held until his recent appointment as assistant to the president, as above noted.

Major Charles Hine, vice-president of the Southern Pacific of Mexico and the Arizona Eastern, has resigned, effective October 16, to return to the field of expert railway work along organization and efficiency lines.



Charles Hine.

He already has been employed to do work along these lines on the Canadian Northern and while engaged on this his headquarters will be at Toronto, Ont. His permanent headquarters, however, will be at New York City. Major Hine was born March 15, 1867, at Vienna, Va., and was graduated from the Washington (D. C.) high school in 1885 and from the United States Military Academy at West Point in 1891. He was graduated from the Cincinnati Law School and admitted to the bar in 1893 while serving as lieutenant in the United States Army. He began

railway work in April, 1895, and for three years was employed by the Cleveland, Cincinnati, Chicago & St. Louis successively as freight brakeman, switchman, yardmaster, conductor, chief clerk and trainmaster of the Cincinnati-Indianapolis district. He was then granted leave of absence in April, 1898, to serve in the Santiago campaign of the Spanish-American war as Major U. S. Volunteers, returning to the Big Four in February, 1899, as trainmaster at Cincinnati, O. In September of that year he was made general superintendent of the Findlay, Ft. Wayne & Western. He was inspector of safety appliances for the Interstate Commerce Commission in 1900, resigning November 1 of that year to go to the Chicago & Alton as assistant superintendent

at Roodhouse, Ill. Major Hine was receiver of the Washington, Arlington & Falls Church Electric railway 1907 to 1908, and subsequently held various staff positions in special work and reports on the Chicago & Alton, Chicago, Rock Island & Pacific, St. Louis & San Francisco, Chicago & Eastern Illinois, Chicago, Burlington & Quincy, Erie, Intercolonial, Prince Edward Island, Delaware & Hudson, Georgia & Florida railroads and National Railways of Mexico as well as other smaller roads. While with Gunn, Richards & Company, in 1907, he assisted in a revision of the business methods in the Department of the Interior at Washington, D. C. As temporary special representative of President Taft in 1910, he outlined a programme for improving organization and methods of executive departments of the United States government. From July, 1908, to December, 1911, as organization expert for the Union Pacific and Southern Pacific, he originated and installed the Hine unit system of organization. He was then in January, 1912, made vice-president and general manager of the Southern Pacific of Mexico and the Arizona Eastern, which position he now resigns, as above stated. Major Hine is the author of "Letters from an Old Railway Official to His Son," published by the *Railway Age Gazette*, and of other works.

**Operating Officers.**

John S. King has been appointed terminal trainmaster of the Cincinnati, New Orleans & Texas Pacific at Cincinnati, O.

O. E. Coyne, chief train dispatcher of the Missouri Pacific at Jefferson City, Mo., has been appointed trainmaster at that place, succeeding D. O. Ouellet, who has been transferred to Sedalia, Mo., in a similar capacity. W. J. Henry succeeds Mr. Coyne.

The position of general superintendent of freight transportation of the New York Central Lines at Chicago has been abolished. H. J. Merrick, who held that office, has resumed his former position as superintendent of freight transportation of the Lake Shore & Michigan Southern, with headquarters at Cleveland, O.

Edward J. Devans, whose appointment as general superintendent of the Buffalo, Rochester & Pittsburgh, with headquarters at Rochester, N. Y., has been announced in these columns, was



E. J. Devans.

born on January 27, 1867, at Medina, N. Y., and was educated in the public schools. He began railway work in May, 1883, as an operator on the New York Central & Hudson River, and then held the same position on the Delaware, Lackawanna & Western and the West Shore until October, 1887, when he went to the Buffalo, Rochester & Pittsburgh as agent and operator. Two years later he was transferred to the superintendent's office as clerk, and in April, 1893, went to the train dispatcher's office as copier, becoming train dispatcher in August of the same year. In Sep-

tember, 1899, he was appointed chief dispatcher and trainmaster, and in May, 1905, was made special representative to the general manager. He was promoted to superintendent in March, 1907, which position he held at the time of his recent appointment as general superintendent of the same road, as above noted.

**Traffic Officers.**

J. Lee Barrett has resigned as northern passenger agent of the Cincinnati, Hamilton & Dayton at Detroit, Mich., to become secretary of the Detroit Convention and Tourist Bureau.

George A. Jobs has been appointed traveling immigration agent of the Northern Pacific, with headquarters at Cincinnati, O., to succeed J. C. Eaton, recently appointed general agent of the passenger department at Cincinnati.

C. F. Gourley has been appointed New England passenger agent of the Boston & Maine, with headquarters at Boston, Mass., succeeding A. C. Robinson, assigned to other duties. Mr. Gourley will also act as immigrant agent.

F. P. Cruice, assistant general passenger agent of the Atchison, Topeka & Santa Fe at Prescott, Ariz., has been appointed assistant general freight and passenger agent of the Santa Fe Coast Lines, with headquarters at Prescott, in charge of solicitation.

Brooks G. Brown, whose appointment as assistant general freight agent of the Southern Railway, with headquarters at Atlanta, Ga., has been announced in these columns, was born on December 2, 1880, at Decatur, Ga., and graduated from high school. On December 1, 1899, he began railway work in the office of the division freight agent of the Southern Railway at Atlanta, and later was transferred to Washington, D. C. He was subsequently rate clerk in the general freight office at Atlanta, and in November, 1905, became traveling freight agent at Spartanburg, S. C. On January 1, 1907, he was made executive clerk in the general freight office of the same road, at Atlanta, and from June, 1909, to the following August, was assistant chief clerk, later becoming chief rate clerk in the same office. He was appointed chief clerk to the general freight agent of the same road in June, 1911, and now becomes assistant general freight agent, as above noted. His entire service has been with the Southern Railway.

#### Engineering and Rolling Stock Officers.

George E. Smart has been appointed master car builder of the Intercolonial and the Prince Edward Island railways, with headquarters at Moncton, N. B.

F. W. Kane, office engineer of the Missouri, Kansas & Texas, has been appointed assistant chief engineer, with headquarters at Dallas, Tex., and his former position has been abolished.

P. Aagard, chief building inspector of the Illinois Central, has been appointed superintendent of buildings, with headquarters at Chicago, succeeding T. J. Fullem, assigned to other duties and the office of chief building inspector is abolished.

George A. Moriarty, whose appointment as master mechanic of the New York, New Haven & Hartford, with headquarters at Boston, Mass., has been announced in these columns, was born on July 24, 1872, at Connellsville, Pa., and was educated in the schools of Cincinnati and the high schools of Newark, Ohio. He began railway work in February, 1887, as a machinist apprentice on the Baltimore & Ohio, and from March, 1891, to September, 1895, was machinist successively on the Pennsylvania Railroad, the Baltimore & Ohio, the Louisville & Nashville, the Cincinnati, New Orleans & Texas Pacific, and the Cleveland, Cincinnati, Chicago & St. Louis. He then returned to the service of the Baltimore & Ohio as machinist, and was subsequently machine shop foreman and general foreman on the same road. From August, 1898, to July of the following year he was in a contract shop, and then to May, 1903, was first a gang foreman on the Baltimore & Ohio, then roundhouse foreman, and later general foreman. In June, 1903, he went to the Erie as general foreman, and later became master mechanic, leaving that company in August, 1907, to become master mechanic of the New York, New Haven & Hartford on the Old Colony division at Providence, R. I., which position he held at the time of his recent appointment as master mechanic of the same road, with headquarters at Boston, Mass., as above noted.



G. A. Moriarty.

J. E. O'Brien, superintendent of motive power of the Western Pacific at Jeffery Shops, Cal., has been appointed assistant mechanical superintendent of the Missouri Pacific and St. Louis, Iron Mountain & Southern, with headquarters at St. Louis, Mo., effective October 8.

C. E. Denney, signal engineer of the Lake Shore & Michigan Southern, at Cleveland, Ohio, has been appointed special engineer on the staff of Vice-President J. J. Bernet, at Chicago, of the New York Central Lines West, and F. B. Wiegand, assistant signal engineer at Cleveland, succeeds Mr. Denney.

The jurisdiction of D. R. MacBain, superintendent of motive power of the Chicago, Indiana & Southern, having been withdrawn, J. T. Flavin, master mechanic, will assume charge of the locomotive and car departments of that road, reporting to the superintendent. E. M. Wilcox is appointed general car foreman, reporting to the master mechanic. Headquarters, Gibson, Ind. Effective October 1.

A. F. Blaess, whose appointment as district engineer of the Yazoo & Mississippi Valley, with headquarters at Memphis, Tenn., has already been announced in these columns, was born in 1871 at Ann Arbor, Mich. He was graduated from the University of Michigan in 1895, with the degree of C. E., and began railway work in July of that year with the Detroit & Mackinac. He was employed as chainman and rodman on the engineering corps making preliminary and location surveys during 1895 and 1896, and the following year he entered the service of the Illinois Central, being a track apprentice for the first three months. He was then transferred to the engineering department, where he was employed in various positions, from rodman to assistant engineer in the construction and maintenance department, until 1902, when he was made road supervisor. He was advanced to roadmaster in 1905, and in 1911 became assistant engineer maintenance of way, with jurisdiction also over the Yazoo & Mississippi Valley. Mr. Blaess remained in the latter position until his recent appointment as district engineer of the Yazoo & Mississippi Valley, as above noted.

#### Purchasing Officers.

William R. Shoop, purchasing agent of the Buffalo, Rochester & Pittsburgh, at Rochester, N. Y., has been appointed manager of purchases and stores, with headquarters at Rochester, effective November 1.

#### Special Officers.

George A. McNicholl has been appointed commissioner of the colonization and industrial department of the Grand Trunk Pacific, with office at Prince Rupert, B. C.

#### OBITUARY.

William E. Barnett, formerly from January, 1900, to 1904, third vice-president of the New York, New Haven & Hartford, died at Pinehurst, N. C., on October 9. He was born on February 20, 1845, at Charleston, S. C., and graduated from Yale with the class of 1864, and later completed a course in the Albany Law School. His first railway work was as private secretary to President Bishop of the New York & New Haven in 1869. He was subsequently executive secretary of its successor, the New York, New Haven & Hartford, which position he held until 1887. Later he was made attorney, and in 1900 became vice-president at the head of the department of law, real estate and taxes.

Charles A. Florence, export and import agent of the Illinois Central at Chicago, died in that city on October 7. He was born on June 8, 1857, at Chicago, and began railway work in 1875 as a clerk. From 1879 to 1887 he was agent in the Chicago, St. Louis & North Western, and then to 1890, was agent of the Iowa Railroad Land Company and then to 1891, was traveling passenger agent of the Illinois Central for Carthage, Mo., and had been in the continuous service of that road ever since. From February, to November, 1890, he was New England passenger agent, and then to September, 1897, was general freight and passenger department for New England and Massachusetts, becoming general eastern freight agent in December, 1897, at New York. In September, 1910, he was appointed assistant general freight agent at Chicago; in May, 1912, he was made assistant general foreign freight agent, and to the first of March, 1912, had been export and import agent of the same

Joseph Robinson Parrott, president of the Florida East Coast, with headquarters at St. Augustine, Fla., died suddenly on October 13 at his summer camp at Oxford, Me. He was born on

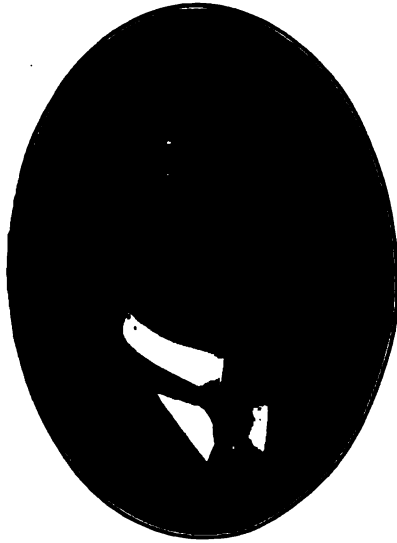

J. R. Parrott.

October 30, 1859, at Oxford, and was educated at Yale, graduating also from the law school. His first railway work was as attorney on the Jacksonville, Tampa & Key West, and he was subsequently appointed general counsel and land commissioner, which position he held until June, 1892; from 1890 to 1892 he was also receiver of the Florida Southern; was general counsel of the Jacksonville, St. Augustine & Halifax River and its successor, the Jacksonville, St. Augustine & Indian River. In 1902 he became vice-president of the same road, which is now known as the Florida

East Coast, and in 1910 was elected president of the same road. He had been closely associated with the late Henry M. Flagler in the railroad and hotel business, and assisted Mr. Flagler in building the oversea extension of the Florida East Coast to Key West.

William McCullough Grafton, signal engineer of the Pennsylvania Lines West of Pittsburgh, Pa., with headquarters at that city, died on October 10, at Atlantic City, N. J. He was born on



W. McC. Grafton.

October 12, 1854, at Yellow Creek, Ohio, and began railway work in 1870, as chief mileage clerk on the Pittsburgh, Fort Wayne & Chicago. One year later he became station agent on the same road and subsequently became coal inspector on the Pittsburgh, Cincinnati & St. Louis. From February, 1877, to July, 1881, he was conductor on the Potomac, Fredericksburg & Piedmont, and then to January, 1882, was assistant superintendent of the same road, becoming general superintendent of that road in 1882. From 1885 to 1886 he was out of railway service and then was ap-

pointed supervisor of signals on the Pennsylvania Lines West of Pittsburgh. Mr. Grafton had been signal engineer of the Pennsylvania Lines West of Pittsburgh since August, 1889, and since January, 1905, was signal engineer also of the Vandalia Railroad. He was one of the most accomplished engineers in this field, but was a modest man and was not prominent in the Signal Association. It was he who first made an extensive installation of the now popular three-position automatic block signals. The Railway Signal Association at the meeting in Nashville, Tenn., on October 14, adopted resolutions testifying to his worth. He was a pioneer among signal engineers and had not only the courage of his convictions, but the energy and determination to bring them to a realization. He had a broad conception of the art of signaling. His work has had and will continue to have an important influence on the development of this branch of railway engineering, and his upright and useful life as a gentleman and a railway officer is a cherished example to his friends and associates.

## Equipment and Supplies.

### LOCOMOTIVE BUILDING.

THE CHICAGO & NORTH WESTERN has ordered 20 mikado locomotives from the American Locomotive Company.

THE CHICAGO & WESTERN INDIANA has ordered 4 mogul locomotives and 6 switching locomotives from the Lima Locomotive Corporation.

THE CENTRAL OF NEW JERSEY has ordered 5 eight-wheel switching locomotives and 10 ten-wheel locomotives from the Baldwin Locomotive Works.

THE LAKESIDE & MARBLEHEAD has ordered 1 six-wheel switching locomotive from the American Locomotive Company. The dimensions of the cylinders will be 21 in. x 28 in., the diameter of the driving wheels will be 51 in., the steam pressure will be 180 lbs. and the total weight in working order will be 165,000 lbs.

THE CENTRAL RAILWAY OF BRAZIL has ordered 6 ten-wheel locomotives from the American Locomotive Company. The dimensions of the cylinders will be 16 in. x 20 in., the diameter of the driving wheels will be 48 in., the steam pressure will be 180 lbs. and the total weight in working order will be 80,000 lbs.

THE DORADO EXTENSION RAILWAY OF COLOMBIA has ordered 2 prairie type locomotives from the American Locomotive Company. The dimensions of the cylinders will be 15 in. x 20 in., the diameter of the driving wheels will be 40 in., the steam pressure will be 175 lbs. and the total weight in working order will be 82,000 lbs.

THE MINNEAPOLIS, ST. PAUL & SAULT STE. MARIE has ordered 6 consolidation locomotives and 4 Pacific type locomotives from the American Locomotive Company. The consolidation locomotives will have 25 in. x 30 in. cylinders, 63 in. driving wheels, a steam pressure of 170 lbs. and a total weight in working order of 226,000 lbs. The Pacific type locomotives will have 25 in. x 26 in. cylinders, 75 in. driving wheels, a steam pressure of 180 lbs. and a total weight in working order of 260,000 lbs.

### CAR BUILDING.

THE SOUTHERN RAILWAY is said to be in the market for 500 hopper cars.

THE J. B. JENKINS COAL & COKE COMPANY, Elkins, W. Va., is considering the purchase of 400 fifty-ton hopper cars.

THE CHICAGO, BURLINGTON & QUINCY has ordered 500 fifty-ton gondola cars from the Haskell & Barker Car Company.

THE MISSOURI PACIFIC is in the market for 100 all steel passenger cars, including chair cars, coaches, baggage cars and express cars.

THE BUFFALO, ROCHESTER & PITTSBURGH is in the market for 1,000 forty-ton box cars, 1,000 fifty-ton gondola cars and 1,000 fifty-ton hopper cars.

THE CHICAGO & NORTH WESTERN has ordered 1,000 gondola cars from the Western Steel Car & Foundry Company and 1,000 gondola cars from the American Car & Foundry Company.

### IRON AND STEEL.

THE CHICAGO, BURLINGTON & QUINCY has ordered 25,000 tons of rails from the Illinois Steel Company.

THE ERIE RAILROAD has ordered 4,000 tons of titanium open hearth rails for severe curve service from the Carnegie Steel Company.

THE GREAT NORTHERN has ordered 20,000 tons of rails from the Illinois Steel Company, and 5,000 tons each from the Lackawanna Steel Company and the Bethlehem Steel Company.

NEW LINE FOR ECUADOR.—The Ecuadorian congress has just passed a law authorizing the construction of a railroad from Quito to the coast in the province of Esmeraldas, a distance of from 90 to 120 miles.



## Supply Trade News.

B. T. Lewis, western manager of the Railway Appliances Company, Chicago, died on October 11.

C. C. Whittier, manager of the Winnipeg, Man., office of the Robert W. Hunt Co., Ltd., Chicago, has been made treasurer and general manager of that company, with headquarters in Montreal, Que.

The Galena Signal Oil Company of Franklin, Pa., has bought about three acres of land at Clearing, Ill., on which to build steel storage tanks, a concrete and brick warehouse, and a power plant.

E. E. Hudson has been made fourth vice-president of Thomas A. Edison, Inc., Orange, N. J., with office at Orange. Mr. Hudson will continue as heretofore in charge of the sales of the Primary battery department.

Chester H. Jones has been placed in charge of the steam railroad department of the General Electric Company's new St. Louis district office. Mr. Jones has been connected with the steam railroad department in the Chicago territory.

Blake C. Howard, heretofore southwestern sales manager of B. W. Mudge & Co., has opened offices in the Railway Exchange building, St. Louis, Mo., to handle a general line of railway supplies. He will continue to represent B. W. Mudge & Co., together with other accounts.

The Canton Foundry & Machine Company, Canton, Ohio, has recently installed in the North Billerica, Mass., shops of the Boston & Maine, six portable cranes; and three portable cranes in the Scranton, Pa., shops of the Delaware, Lackawanna & Western. This company has also sold to the New York Central Lines one No. 4 Canton allegator shear; to the Boston & Albany, one No. 3 motor driven allegator shear; to the Chicago, Rock Island & Pacific, one No. 2 motor driven allegator shear; to the Elgin, Joliet & Eastern, two 8 ft. turntables for the Joliet, Ill., shops; and to the Central Railroad of New Jersey, thirteen 8-ft. turntables for the Elizabeth, N. J., shops.

### TRADE PUBLICATIONS.

**PNEUMATIC TOOLS.**—The Chicago Pneumatic Tool Company has issued bulletin 34-T, describing its class "M" Chicago Pneumatic Corliss type steam driven compressors.

**FIREPROOF FLOOR CONSTRUCTION.**—The Clinton Wire Cloth Company, Clinton, Mass., has issued a booklet of 34 pages, describing and illustrating a test conducted at the Columbia Fire Testing Station, Brooklyn, N. Y., on July 30, 1913, by Harold Perrine, of the University of Columbia, upon so-called fireproof floors, consisting of a floor slab of cinder concrete, one of terra cotta and one of gypsum and shavings. The test was a fire, load and water test for the purpose of comparing the fireproofing properties of the three different types. An average temperature of 1,700 deg. Fahr. was maintained for four hours against the under side of the slabs, which carried at the same time a load of 150 lbs. per sq. ft. At the end of four hours the under sides of the slabs, while hot, were subjected to water pressure of about 60 lbs. per sq. in. for five minutes through a standard fire nozzle  $1\frac{1}{8}$  in. in diameter. The top of the floor was then flooded at low pressure and the under surface of the slabs again subjected for five minutes to 60 lbs. pressure from the hose. On the following day after the floors had cooled they were then loaded with 600 lbs. per sq. ft., and the deflections were recorded. The concrete cinder and the gypsum slabs were reinforced with Clinton electrically welded wire. The cinder concrete floor went through the entire test practically uninjured and sustained a final loading of 600 lbs. per sq. ft. with a deflection of only  $\frac{9}{32}$  of an inch. The gypsum slab suffered a loss of all material below the reinforcement at the end of the water test and failed before the load of 600 lbs. was reached. The terra cotta floor showed a splitting and breaking of the lower webs of a number of the blocks when the water was applied and the destruction of their lower webs under the application of the load of 600 lbs. Full details of the test, together with photographs and diagrams are included in the pamphlet.

## Railway Construction.

**ALGOMA CENTRAL & HUDSON BAY.**—The section of the Algoma Eastern to Goat Island was opened for traffic on September 15, and the line is now being operated from Sudbury, Ont., to Goat Island, at which point a roundhouse and machine shop has been built. A bridge is under construction to connect Goat Island with Little Current, on Manitoulin Island, and it is expected will be ready for traffic about November 1. The passenger station and freight sheds will be located at Little Current. (July 18, p. 131.)

**ALGOMA EASTERN.**—See Algoma Central & Hudson Bay.

**BRITISH COLUMBIA ELECTRIC.**—This company is negotiating with the Great Northern for the purchase of the abandoned right of way of the Cloverdale-Blaine line between Hazelmer and the International boundary at Blaine, Wash. The proposed line will connect with the line projected by the Stone & Webster Corporation, to Bellingham, Wash., and an extension may be built to the mouth of the Campbell river.

**CANADIAN PACIFIC.**—The Board of Railway Commissioners of Canada has approved the revised location plans on the Pacific division for the Kootenay Central, under construction by the Canadian Pacific, from mileage 37.35 southeasterly to mileage 57.19, and also approved the revised location plans of the Bassano easterly branch from mileage 98.72 to 115.59.

Preliminary work for the electrification of the Castlegar-Rossland section of the Canadian Pacific is under way. The power plant of the West Kootenay Power & Light Company is being increased to meet the Canadian Pacific requirements.

**CANADIAN ROADS.**—The city council of Winnipeg, Man., has passed a by-law providing for a water supply for the city from Shoal Lake at a cost of \$13,500,000. The report of the engineers on which the estimated cost is based contains \$1,020,000 to provide a standard gage railway from the point where the aqueduct leaves the Grand Trunk Pacific to Indian Bay, 85 miles, which is about \$12,000 a mile, for building such a line.

**CHICAGO, PEORIA & QUINCY TRACTION.**—An officer writes regarding the reports that this company will build a line to connect Quincy, Ill., with Peoria, that the company expects to start the work about April 1, 1914. J. L. Soebbing, president, Quincy, and the Chapman Company, Steger building, Chicago, is in charge of the engineering work.

**CHICAGO, ROCK ISLAND & PACIFIC.**—The report of this company for the year ended June 30, 1913, shows that the St. Paul & Kansas City Short Line between Carlisle, Iowa, and Allerton, Iowa, was opened for through passenger and freight train service on September 14, 1913. Construction of the Malvern & Camden from Malvern, Ark., to Camden, has been completed since the close of the fiscal year, and it was opened for operation on October 1, 1913. Industrial tracks were constructed to 77 private industries and to six coal mines, necessitating the construction of 83 tracks during the year, and additional track improvement was made, re-arranging and extending tracks to fifteen industries. During the year the company also completed work on additional and improved terminal facilities.

**COLORADO, WYOMING & NORTHERN.**—Incorporated in Colorado with \$5,000,000 capital, to build 100 miles of railroad from the Denver & Salt Lake near the confluence of the Elk and Bear rivers in Colorado north to a connection with the Union Pacific at Rawlins, Wyo. The directors include G. W. Bowen, W. J. Van Mannen, J. C. Buck, and O. L. Dines. The same interests will develop coal fields in Routt and Moffat counties, Colo. It is understood that financial arrangements have been made with Belgian capitalists to secure the necessary capital. The headquarters of the company will be in Denver, Colo., and in Toronto, Can.

**COOS BAY & COQUILLE VALLEY.**—An officer writes that grading work is now under way by Willet & Burr, San Francisco, Cal., from Myrtle Point, Oregon, following the south fork of Coquille river to Wagner Branch, 22 miles, and track has been laid on eight miles. The maximum grades will be  $1\frac{1}{10}$  per cent., and the maximum curvature 12 deg. There will be six Howe truss bridges, one tunnel, and three miles of trestles on the line.

The company expects to develop a traffic in logs, farm products and gravel. F. A. Haines, chief engineer of construction.

**DOMINION ATLANTIC.**—The Board of Railway Commissioners of Canada has approved of a revised location for the North Mountain branch between Grafton, N. S., and Torn Lake, in Cornwallis Township.

**EAST & WEST COAST.**—An officer writes that the prospects of building from Bradentown, Fla., to Arcadia, 52 miles, are good. Maximum grades will be one-half per cent.; maximum curvature one and one-half degrees. The company expects to develop a traffic in lumber, fruits, vegetables and phosphates. Allen W. Jones is president and general contractor, Bradentown.

**FLORIDA EAST COAST.**—An officer writes that grading work on the Kissimmee Valley division has been completed from Maytown, south to Kenanville, thence southeasterly via Apoxsee, Lokosee, Yeehaw, Osowaw, Focho and Hilolo, to Okeechobee, 123 miles. The section from Maytown to Kenanville, 72.5 miles is now in operation. In addition, grading work has been completed from Kenanville on a branch south to Bassenger, 36 miles. The work was carried out by the Kissimmee Valley Construction Company, Jacksonville, Fla., and involved handling about 3,000 cu. yds. to the mile, of which 10 per cent. was excavation work. The maximum grades are 4/10 of 1 per cent., and maximum curvature 3 deg. A 50-ft. Strauss bascule bridge was built over the St. Johns river, and there is an 800-ft. standard trestle over Ecolarkhatchee creek, and a 1,500-ft. standard trestle over St. Johns river, also a number of smaller structures varying in length from 10 to 60 ft. each. The company expects to develop a traffic in naval stores, manufactured lumber and citrus fruits. It is expected that track will be laid to Okeechobee, also on the branch to Bassenger during the early part of 1914.

**GULF, FLORIDA & ALABAMA.**—An officer writes that the 20-mile extension of the main line north of Local, Ala., will be accepted from the contractor before November 1, at which time the company expects to place the extension in operation. With this extension, the company will have in operation 106 miles. A contract for grading and additional 50 miles to a connection with the Southern Railway, near Pine Hill, Ala., has just been let to James T. McCarthy & Company, involving the handling of approximately 1,500,000 yds. of classified excavation. Under the terms of the contract the work must be completed in time for the extension to be opened by September 1, 1914. Plans are now being made for the necessary bridging to carry the line over the Alabama river near Yellow Bluff, which will consist of a draw span and the necessary truss approach spans, as well as some steel trestle. The total length of the bridge is to be about 2,500 ft. The company expects that both the sub-structure and superstructure contracts will be ready for bids about January 1, 1914. The company's forces are also engaged at a number of places on the existing line, in relocation of line and grade reduction to secure maximum grades of .75 per cent. southbound and 1 per cent. northbound, and extensive additions to the marine terminal at Pensacola are now under way. (October 10, p. 679.)

**ILLINOIS CENTRAL.**—This company has let a contract to J. D. Lynch, Monmouth, Ill., for grading on track depression work at Mattoon, Ill. The contract is worth about \$450,000.

**NIORARA WATER POWER RAILWAY.**—Incorporated in South Dakota with \$16,500,000 capital and headquarters at Omaha, Neb., and at Sioux City, Iowa. The company will secure power from the Niobrara river in Nebraska to operate electric railway lines in northeastern Nebraska, and to enter Iowa at Sioux City and South Dakota at Yankton, at which place a bridge is to be built over the Missouri river. An extension will be built on the south to Omaha. The lines in Nebraska will extend through the counties of Holt, Knox, Cedar, Dixon, Dakota, Thurston, Burt, Cuming, Antelope, Pierce, Madison, Stanton, Colfax, Dodge, Washington and Douglas. The incorporators are: C. W. Baker, Omaha, Neb.; O. S. Christian, Madison; H. P. Bruhman, Lehigh; P. Mangold, Bennington, and G. W. Martens, Pierre, S. Dak.

**NUECES VALLEY, RIO GRANDE & GULF.**—An officer writes that in addition to building from a point about a quarter of a mile east of Kitty, Tex., on the San Antonio, Uvalde & Gulf, to a point near the center of McMullen county, about 25 miles, the

company intends extending the line to connections with other lines, and developing a large section heretofore without rail facilities. The line as projected will follow the valley of the Nueces river most of the way. There will be some trestles on the line and a number of stations are to be put up. The principal commodities to be carried will be cattle and construction material. W. A. Matthaei, president, and J. W. Brooks, chief engineer, Belleville.

**PACIFIC & HUDSON BAY.**—A line is being surveyed, it is said, from Bella Coola, B. C., to Alexis creek, thence across the Cariboo river between mileage 103 and 105 to Beaver, B. C. E. Both, Bella Coola, B. C., is in charge of the surveys.

**ST. ELMO, BELLE HELENA & LOUISIANA EASTERN.**—An officer writes that this company has 11 miles of track laid in Louisiana and that the company expects early next year to build an extension about two miles long. In addition to the use of steam as the motive power, gasolene motor cars will be used. G. W. Reese, president, New Orleans, La.

**SAN ANTONIO & AUSTIN INTERURBAN.**—An officer is quoted as saying that construction work will soon be started on this line. About 40 per cent. of the right of way has been secured from Austin, Tex., southwest via Manchaca, Buda, Kyle, San Marcos, Hunter, and New Braunfels to San Antonio, about 85 miles. (March 28, p. 779.)

**SOUTH DAKOTA CENTRAL.**—This company, it is said, has under consideration the question of building an extension from Watertown, S. D., north into Day county, probably via Webster.

**SOUTHERN RAILWAY.**—The report of this company for the year ended June 30, 1913, shows that construction of the double-track line north of Atlanta, between Cross Keys and Gainesville, Ga. (exclusive of a single-track gauntlet between Suwanee and Duluth) was completed and put in operation during the year. Additional double-tracking was begun during the year between the following points: Amherst and Monroe, Va., New Holland and Gainesville, Ga., Cross Keys and Armour, Ga., and between Twenty-seventh street, Birmingham, and east end of yard at North Birmingham, Ala. With the completion of the double-track between Amherst and Monroe, and between New Holland and Gainesville, both of which are expected to be completed by the latter part of 1913, and that between Cross Keys and Armour, which is expected to be finished early in 1914, the company will have in operation on its main line between Washington and Atlanta 301.07 miles of double-track, or approximately 46 per cent. of the total mileage between those terminals. The track between Twenty-seventh street, Birmingham and the east end of yard at North Birmingham is expected to be in service about January 1, 1914. The additional main track between Constitution and Roseland, Ga., is now in operation. The new double-track connection with the Cincinnati, New Orleans & Texas Pacific at Citico Junction, Tenn., equipped with interlocking signals, was completed and put in service during the year. The Knoxville River Front Extension, also the belt line at High Point, N. C., were completed and put in service during the year. The lap-sidings between Macon and Jesup, Ga., the aggregate length of which is 19,028 ft., also a new gravity yard at Macon, Ga., were completed and put in service during the year. A new line from near Forbes, Va., on the Franklin branch, extending to ore properties, was completed during the year, and a revision of the main line for a distance of 3.3 miles in the vicinity of Parr Shoals, S. C., was made necessary by the construction, by a power company, of a dam in Broad river.

**SOUTHWESTERN TRACTION & POWER COMPANY.**—We are told that this company, operating 13 miles of electric line between New Iberia, La., and Jeanerette, has not yet decided when contracts will be let to complete the through line projected several months ago from Berwick northwest to St. Martinsville, about 75 miles. The plans call for putting up a power house and several sub-stations. (July 25, p. 170.)

**TRI-STATE RAILWAYS COMPANY OF MICHIGAN.**—An officer writes that this company has been incorporated in Michigan to build an interurban line from Adrian, Mich., in Lenawee county, southwest to Elkhart, Ind., with a branch from this line at Manataw beach on Devil's lake in Lenawee county north to Jackson in Jackson county. Some of the right of way has been secured and the prospects for building are good. The company expects to develop a traffic in dairy products, general agricultural prod-

ucts, live stock, lumber, etc. Harry McClave, president, Hillsdale, Mich.

**TRONA RAILWAY.**—An officer writes that grading work is now under way and is being carried out by Robert Sherer & Company, Los Angeles, Cal., on the line from Searles, Cal., on the Southern Pacific, in Kern county, northerly and northeasterly to Searles Lake, in the northwest corner of San Bernardino county, 31 miles. Maximum grades will be 1.75 per cent. compensated and maximum curvature 2 degrees. W. A. Cattell, chief engineer, San Francisco, Cal. (May 16, p. 1115.)

### RAILWAY STRUCTURES.

**BALTIMORE, Md.**—The Baltimore & Ohio will make a large addition to its freight facilities in the Camden station terminal at Baltimore. The plans call for the construction of an out-bound freight house to be 600 ft. long x 20 ft. wide, with four tracks having a capacity of 15 cars each and a platform 8 ft. wide, to be built along Eutaw street, between Lee and Cross streets. The terminal will be built by the railroad forces.

**BATHURST, N. B.**—See Truro, N. S.

**MEMPHIS, TENN.**—The report of the Chicago, Rock Island & Pacific for the year ended June 30, 1913, shows that the Arkansas & Memphis Railway Bridge & Terminal Company was incorporated to build a double track steel bridge across the Mississippi river at Memphis, Tenn. Construction is now under way and this bridge when completed will be equally owned by The Chicago, Rock Island & Pacific, the St. Louis, Iron Mountain & Southern and the St. Louis Southwestern.

**NONCONNAH, TENN.**—The Illinois Central has given a contract to Swift & Co., Chicago, for building a new roundhouse at Nonconnah.

**OIL CITY, PA.**—An officer of the Pennsylvania writes that the erection of a bridge to replace the present structure is contemplated at Oil City, Pa., but definite plans have not as yet been decided upon.

**PENSACOLA, FLA.**—Extensive improvements to the marine terminal of the Gulf, Florida & Alabama are now under way, comprising the dredging, to 31 ft. of depth, of a channel, turning basin and slips for two piers, in addition to the one now in operation, the dredged material being deposited behind a bulkhead, thereby reclaiming thirty acres of land which is to be used for yard and warehouse purposes. The contract for the dredging has been let to the Atlantic, Gulf & Pacific Company, New York. Plans are now being made for a modern coaling dock, on which bids will be asked in time to insure its completion by September, 1914. The additional docks are being built by the company's forces, although contract will shortly be let for the steel frame for a pier shed 100 ft. wide x 1,200 ft. long. See Gulf, Florida & Alabama under Railway Construction.

**ST. CESAIRE, QUE.**—The Montreal & Southern Counties has given a contract to John Ross, of Ross & McComb, it is said, for the concrete sub-structure of a bridge to be built over the Yamaska river at St. Cesaire. The bridge will have four piers and two abutments. It is understood that the Dominion Bridge Company will erect the superstructure.

**ST. MALO, QUE.**—The National Transcontinental has given a contract to J. Gosselin, Levis, Que., it is said, for putting up machine and other shop buildings at St. Malo.

**TRURO, N. S.**—New station buildings are to be erected at Truro, N. S., and at Bathurst, N. B., by the Intercolonial Railway. It is also proposed to overhaul many of the other station buildings on the road.

**VAN BUREN, MAINE.**—The International St. John River Commission having given its formal consent and approved of the project to build an international railroad bridge between Van Buren, Me., and St. Leonards, N. B., the last legal obstacle in the path of the promoters has been removed. Van Buren is one of the terminal points of the Bangor & Aroostook, and St. Leonards is the junction point of three Canadian roads, the Intercolonial, Canadian Pacific and the Grand Trunk Pacific. It is understood that plans are being made for the construction of a link connecting these lines. (May 9, p. 1053.)

## Railway Financial News.

**BOSTON & MAINE.**—See New York, New Haven & Hartford.

**CLEVELAND, CINCINNATI, CHICAGO & ST. LOUIS.**—The Public Utilities Commission of Ohio has authorized the company to issue \$1,578,000 general mortgage bonds, to be sold at not less than 90; and, as has already been noted in these columns, has further modified its order permitting the issue of \$1,000,000 of these bonds at 90 and \$578,000 of these bonds at 81; the \$1,000,000 bonds having, of course, already been sold at 90.

**DELAWARE & HUDSON.**—This company has received permission from the New York Public Service Commission, Second district, to issue \$4,500,000 first and refunding mortgage 4 per cent. bonds of 1908-1943. The bonds are to be sold at not less than 95. The company had asked for authority to issue \$5,000,000 of these bonds, of which \$3,000,000 were to retire a like amount of bills payable incurred for expenditures for additions and betterments, and \$2,000,000 were to be used to pay for future additions and betterments.

**MEMPHIS UNION STATION.**—Potter, Choate & Prentice, New York, are offering \$2,500,000 first mortgage 5 per cent. bonds of November 1, 1913-1959 at 101 $\frac{3}{4}$ , to yield 4.90 per cent. on the investment. The bonds are guaranteed jointly and severally, principal and interest, by the Louisville & Nashville; Nashville, Chattanooga & St. Louis; St. Louis, Iron Mountain & Southern; Southern Railway, and St. Louis Southwestern.

**NEW YORK, NEW HAVEN & HARTFORD.**—The Massachusetts Railroad Commission has finally authorized the company to issue its \$67,552,000 6 per cent. debenture bonds. These bonds are offered to stockholders at par and are convertible after October 1, 1918, and not later than October 1, 1928, into stock at par.

Theodore N. Vall and Alexander Cochrane, both directors of the Boston & Maine, have resigned as directors of the New York, New Haven & Hartford.

**NORFOLK SOUTHERN.**—At the annual meeting the by-laws were changed providing for 19 directors instead of 17. Lewis L. Clarke, president of the American Exchange National Bank, was elected a director and the other vacancy was not filled.

**UNION PACIFIC.**—After the meeting of the board of directors on Thursday of last week Judge Lovett gave out the following statement:

"The question of the disposition to be made of the large cash fund realized by the Union Pacific from the proceeds of the recent sale of Southern Pacific stock, and possibly of certain other assets of the company, has received the urgent and careful attention of the board of directors. The conclusion has been arrived at that existing circumstances make it inexpedient to deal with this subject at present. To avoid misunderstanding, however, it is deemed right to state that none of the various plans which have thus far been considered and discussed contemplated any division of surplus either in cash or securities which in its result would have increased the present yield of the stock."

Judge Lovett was prevailed upon by the *Wall Street Journal* to amplify the last paragraph of his statement. He said: "Personally I see no necessity for any amplification, but to remove any misunderstanding, I may say simply that Union Pacific is a 10 per cent. stock, paying 10 per cent. out of investment income and transportation earnings. It was the purpose of the directors to conserve to the Union Pacific investor that same income. All of the plans considered for an extra dividend provided for a corresponding reduction in the 10 per cent. rate paid on the Union Pacific common stock."

**BOLIVIAN RAILWAY DEVELOPMENT.**—Railway development in Bolivia continues, and the lack of transportation facilities is being gradually lessened. Although on the Pacific side the republic is fairly provided with communications by means of the Antofagasta, the Arica to La Paz, and the La Paz to Huaqui Railways (the latter connecting via Lake Titicaca with the Peruvian port of Mollendo), the Atlantic side is only served by the rivers assisted by the Madeira & Mamoré Railway.

# ANNUAL REPORTS.

## SOUTHERN RAILWAY—NINETEENTH ANNUAL REPORT.

WASHINGTON, D. C., October 3, 1913.

To the Stockholders of the Southern Railway Company:

The Board of Directors submits the following report of the affairs of the Company for the year ended June 30, 1913:

### INCOME STATEMENT.

	1913.	1912.	Increase or Decrease.
Miles of Road Operated, Average .....	7,035.61	7,088.03	Dec. 52.42
Gross Operating Revenues...	\$68,529,490.20	\$63,590,328.90	Inc. \$4,939,161.30
Total Operating Expenses...	48,273,923.55	43,696,236.39	Inc. 4,577,687.16
Net Operating Revenue....	\$20,255,566.65	\$19,894,092.51	Inc. \$361,474.14
Auxiliary Operations—Net Revenue .....	80,535.87	64,754.67	Inc. 15,781.20
Net Revenue .....	\$20,336,102.52	\$19,958,847.18	Inc. \$377,255.34
Taxes .....	2,480,387.28	2,452,328.28	Inc. 28,059.00
Operating Income .....	\$17,855,715.24	\$17,506,518.90	Inc. \$349,196.34
Other Income .....	3,365,970.50	3,580,441.70	Dec. 214,471.20
Total Gross Income....	\$21,221,685.74	\$21,086,960.60	Inc. \$134,725.14
Deductions from Income....	3,104,086.17	3,180,139.70	Dec. 76,053.53
Total Available Income...	\$18,117,599.57	\$17,906,820.90	Inc. \$210,778.67
Interest on Mortgage, Bonded and Secured Debt.....	11,038,974.40	11,143,703.84	Dec. 104,729.44
Balance of Income over Charges .....	\$7,078,625.17	\$6,763,117.06	Inc. \$315,508.11
Dividends on Preferred Stock:			
No. 23, Two Per Cent., paid in April, 1912; No. 25, Two and One-Half Per Cent., paid in April, 1913.	\$1,500,000.00	\$1,200,000.00	Inc. \$300,000.00
No. 24, Two and One-Half Per Cent., paid in October, 1912; Reserve for Dividend No. 26, Two and One-Half Per Cent., payable in October, 1913.	1,500,000.00	1,500,000.00	
Total Dividends .....	\$3,000,000.00	\$2,700,000.00	Inc. \$300,000.00
Balance over Dividends on Preferred Stock .....	\$4,078,625.17	\$4,063,117.06	Inc. \$15,508.11
Additions and Betterments..	48,660.48	44,989.42	Inc. 3,671.06
Balance carried to Credit of Profit and Loss...	\$4,029,964.69	\$4,018,127.64	Inc. \$11,837.05

### PROFIT AND LOSS.

The surplus shown by the Profit and Loss statement as of June 30, 1912, was \$13,756,936.13. After making provision through Income for the full Dividend on the Preferred Stock, amounting to \$3,000,000, and charging to Profit and Loss \$98,332.96, Discount on Securities, thus extinguishing the entire amount of such discount, and \$314,009.66, representing net miscellaneous accounts written down, the surplus as of June 30, 1913, amounted to \$17,374,558.20, a gain of \$3,617,622.07 over the preceding year.

### DISCOUNT ON SECURITIES.

The Discount on Equipment Trust Obligations and other securities sold by the Company during the year amounted to \$110,350.00, of which \$12,017.04 was charged to Income and the balance, \$98,332.96, to Profit and Loss.

### INTEREST.

The accrued interest on Mortgage, Bonded and Secured Debt for the year ended June 30, 1913, was \$104,729.44 less than for the preceding year. The interest on Equipment Trust Obligations decreased \$5,604.43 and on Bonds and Notes \$99,125.01, due principally to the retirement at maturity February 1, 1913, of \$5,000,000 of the Company's Three-Year Five Per Cent. Notes.

### DIVIDENDS.

A dividend of Two and One-Half Per Cent. on the Preferred Stock of the Company was paid April 24, 1913, and provision has been made for the payment on October 30, 1913, of a dividend of Two and One-Half Per Cent. declared out of Income earned during the year.

### PROPERTY INVESTMENT AND MORTGAGE DEBT.

The investment in physical property, exclusive of depreciation, increased \$3,516,514.27, of which \$2,927,739.04 was in Roadway and Structures and \$588,775.23 in Equipment. This increase represents net additions made during the year. (See pages 24 and 25.)

During the year there was a decrease of \$3,628,600 in outstanding Mortgage and Collateral Trust Bonds and Notes and \$1,234,000 in Equipment Trust Obligations. (See page 28.)

The \$10,000,000 Three-Year Five Per Cent. Notes issued in 1910, were retired by the payment at maturity, February 1, 1913, of \$5,000,000 in cash out of Treasury funds, and with the proceeds from the sale of \$5,000,000 Three-Year Five Per Cent. Notes dated February 1, 1913.

There were paid at maturity, April 10, 1913, \$150,000 Atlantic, Tennessee and Ohio Railroad Company First Mortgage Six Per Cent. Bonds, and a like amount of Southern Railway Company First Consolidated

Mortgage Five Per Cent. Bonds were drawn therefor as provided in the mortgage.

On June 4, 1913, there were sold \$1,500,000 Southern Railway Company First Consolidated Mortgage Five Per Cent. Bonds, therefore free in the Treasury, to reimburse the Treasury, in part, for expenditures incident to additions and betterments.

There were retired during the year, through the sinking fund provisions of the mortgages, \$30,600 Charlottesville and Rapidan Railroad Company First Mortgage Six Per Cent. Bonds and \$6,000 Franklin and Pittsylvania Railroad Company First Mortgage Six Per Cent. Bonds, \$37,000 First Consolidated Mortgage Five Per Cent. Bonds were drawn on account thereof and placed in the Treasury.

By reason of these and previous drawings for similar purposes, and the sale of \$1,500,000 Southern Railway Company First Consolidated Mortgage Five Per Cent. Bonds, there remained free in the Treasury on June 30, 1913, \$1,114,800 of these bonds.

During the month of June, 1913, there were drawn and taken into the Treasury \$5,000,000 Development and General Mortgage Four Per Cent. Bonds, which, under the terms of that mortgage could be drawn during the calendar year 1913 to reimburse the Company for expenditures made for additions and betterments. In like manner there were also drawn and taken into the Treasury during the year \$1,130,000 of these Bonds to reimburse the Company for proportion of Equipment Trust Obligations paid during the year and charged to capital account.

As the result of these drawings, the total amount of Development and General Mortgage Four Per Cent. Bonds free in the Treasury on June 30, 1913, was \$25,992,000.

The Company has continued the conservation of its Working Assets through the employment of its Treasury funds.

### ADDITIONS AND BETTERMENTS.

Construction of the double-track line north of Atlanta, between Cross Keys and Gainesville, Ga. (exclusive of a single-track gauntlet between Suwanee and Duluth) referred to in last year's report, was completed and put in operation during the year.

Additional double-tracking was begun during the year between the following points: Amherst and Monroe, Va., New Holland and Gainesville, Ga., Cross Keys and Armour, Ga., and between 27th Street, Birmingham, and east end of yard at North Birmingham, Ala.

With the completion of the double-track between Amherst and Monroe, and that between New Holland and Gainesville, both of which pieces are expected to be completed by the latter part of 1913, and that between Cross Keys and Armour, which is expected to be finished early in 1914, the Company will have in operation on its main line between Washington and Atlanta 301.07 miles of double-track, or approximately 46 per cent. of the total mileage between those terminals. The track between 27th Street, Birmingham and the east end of yard at North Birmingham is expected to be in service about January 1, 1914.

The additional main track between Constitution and Roseland, Ga., referred to in last year's report, is now in operation.

The new double-track connection with the Cincinnati, New Orleans & Texas Pacific Railway at Citico Junction, Tenn., equipped with interlocking signals, referred to in report for the preceding year, was completed and put in service during the year.

The Knoxville River Front Extension, referred to in last year's report, was completed during the year and the entire line is now in operation.

The belt line at High Point, N. C., referred to in last year's report, was completed and put in service during the year.

The lap-sidings between Macon and Jeap, Ga., the aggregate length of which is 19,028 feet, referred to in last year's report, were completed and put in service during the year.

A new gravity yard at Macon, Ga., was completed and put in service during the year.

A new line from near Forbes, Va., on the Franklin Branch, extending to ore properties, was completed during the year.

A revision of the main line for a distance of 3.3 miles in the vicinity of Parr Shoals, S. C., was made necessary by the construction, by a power company, of a dam in Broad River. The expense of this work is to be borne by the power company.

The new passenger station at Lynchburg, Va., the building of which was made necessary by the new double-track line at that point, was put in service October 31, 1912.

The installation of electrical automatic signal system between Denim and Charlotte, N. C., a distance of approximately 96 miles, was completed and placed in operation during the year, and a similar system is under construction between Cameron Run and Orange, Va., a distance of approximately 75 miles.

During the year the Company received the following new and additional equipment: 45 locomotives, 20 steel frame passenger coaches, 10 steel baggage, mail and express cars, 6 steel frame dining cars, 275 steel underframe ventilated box cars, 150 steel underframe automobile box cars, 104 steel flat cars and 4 pieces of road service equipment. It had in course of conversion during the year 600 coal cars, the bodies of which had passed the stage of economical operation, into steel underframe ventilated box cars, of which 551 were completed and placed in service during the year.

Since the close of the year the Company has contracted for the following additional equipment: 25 locomotives, 1,720 fifty-ton steel coal cars and 150 thirty-ton steel underframe stock cars.

### OPERATIONS.

Gross Revenues increased over those of the preceding year \$4,993,161.30. Operating Expenses increased \$4,577,687.16, of which increase 57.14 per cent., or more than one-half, was in maintenance of the property, 33.28 per cent. in transportation, 7.62 per cent. in the development of traffic and 1.96 per cent. in administration expenses. Approximately 37.68 per cent. of the increase in the cost of transportation was due to higher wage schedules.

### Freight Traffic:

Freight revenues increased over those of the preceding year \$3,435,447.44. The growth in production and in the consuming energy of the territory served by the Company's lines is reflected in its classified tonnage statistics.

These statistics reveal increased tonnage in a period of ten years as follows:

Products of Agriculture.....	1,037,699 tons, or 42.1 per cent.
Products of Animals.....	53,689 tons, or 19.9 per cent.
Products of Mines.....	3,528,532 tons, or 42.8 per cent.
Products of Forest.....	1,921,428 tons, or 62.4 per cent.
Manufactures and Miscellaneous...	3,710,757 tons, or 72.3 per cent.

Total Increase ..... 10,252,105 tons, or 53.4 per cent.

Production in excess of local need creates tonnage for distant markets, and the increase in the tonnage of the products of the soil, forest and factory illustrates a remarkable expansion in the distribution of the products of the section the Company serves.

The production of grain in the Southeast has increased largely in recent years, but in the section as a whole the production is not yet in excess of the local demand although with the more general adoption of diversified farming the tendency is strongly in that direction.

The volume of other agricultural products is steadily increasing and the Southeast is supplying other sections of the country in larger measure each year with its fruits and vegetables.

The expansion of industrial enterprise keeps well abreast with the progress of the country at large, and there is a steady increase in tonnage of the products of mines and forest and of manufactures.

#### Passenger Traffic:

The passenger traffic of the Company has shown a gratifying increase during the year, the increase in revenues therefrom being \$1,280,678.07. An important factor in bringing this about is the geographical location of the system with reference to the currents of commercial travel and to the summer and winter tourist resorts of the Southeast. Reaching most of the principal commercial centers of the section the Company's lines are favorably located for travel within the territory and between it and other sections of the United States. Increasing numbers of conventions, re-unions, religious assemblies and similar gatherings are being held at points on the Company's lines, and in connection with the religious assemblies there is in progress a noteworthy development of community life in the summer resort regions in the mountainous territory served by the Company, resulting in a substantial increase in travel over its lines.

Details of operations of the Company are set forth in the report of the Vice-President and General Manager, hereto annexed.

### RELATIONS OF THE COMPANY TO THE PROGRESS OF THE SOUTH.

During the year the Company has continued and still further expanded its broad work in aid of agricultural and industrial development in the territory traversed by its lines.

#### Agriculture:

The rate at which agricultural development is adding to the wealth of the nine Southeastern States traversed by the Company's lines is indicated by United States Census figures showing that the value of farm property increased from \$2,189,114,320 in 1900 to \$4,461,411,250 in 1910, an increase of \$2,272,296,930, or 103.8 per cent., a much higher percentage of increase than is shown for any other group of older states. During the decade covered by the Census the total annual value of all farm crops produced in those states increased from \$593,843,573 to \$1,199,424,319, an increase of \$605,580,746, or 102 per cent., which is also a more rapid rate of increase than is shown by any other group of older states.

The most marked tendency of agricultural progress in the Southeast is in the direction of wider diversification and increased attention to live stock. At the same time the production of distinctively Southern crops is being maintained and increased. This may be strikingly illustrated by statistics of cotton and corn. Cotton production in the States traversed by the Company's lines increased from 4,967,490 bales in 1900 to 6,876,023 bales in 1912, an increase of 1,908,533 bales, or 38.4 per cent. While cotton production was thus being more than maintained, the corn crop was increased from 290,231,843 bushels in 1900 to 504,135,000 bushels in 1912, an increase of 213,903,157 bushels, or 73.7 per cent.

The Company's Department of Farm Improvement Work is continuing to be an effective factor in bringing about increased agricultural production in the territory along its lines. On farms where its advice has been followed crop yields per acre have been substantially larger than on similar lands in the same localities where this advice has not been followed. This may be illustrated by a case in which a farmer followed the advice of the Department on part of a field from which he harvested 35 bushels of wheat as compared with 10½ bushels on the remainder of the same field which was farmed in accordance with his old methods. A preliminary report of the Manager of this Department for the current year shows that its Field Agents were actively co-operating with 2,374 farmers and that 62,090 acres were being cultivated under their personal instructions. The scope of the Department's work is much broader than indicated by these figures, as many farmers not working under personal instructions are following the advice of the Department and as the Manager, Assistant Managers, and Field Agents deliver addresses at meetings of farmers, attend large numbers of farmers' meetings and hold neighborhood meetings in the fields where practical demonstrations of improved methods are given.

The Mexican cotton boll weevil, having spread into territory along the lines of the Company and its Associated Companies in Mississippi and in Western Alabama, special efforts have been made by the Department of Farm Improvement Work, in co-operation with the United States Department of Agriculture, state authorities and local merchants and bankers, to aid the farmers in controlling this insect. These efforts have been so highly successful as greatly to reduce the damage done by the weevil. The results attained have been such as to demonstrate the wisdom of the Company in undertaking, in advance of the appearance of the weevil, to instruct farmers as to its control. There is no other region into which this insect has spread since its first appearance in Texas in which the damage in the first year of its general prevalence has been so small as in the territory along the Company's lines.

The live stock and dairy industries in the territory traversed by the Company's lines have continued to receive helpful attention during the year. Through the operation of a dairy instruction car and through visiting dairymen and farmers, demonstrating the best methods of handling milk and making butter and giving advice as to the selection and management of dairy herds and as to the management of poultry, a substantial development of the dairy and poultry industries along the Company's lines is being brought about. The attention given to the live stock business has resulted in increased movements of cattle to the various feeding grounds along the Company's lines and of butchers stock to market.

#### Marketing Agricultural and Horticultural Products:

Successful marketing being essential to profitable production, the Company and its Associated Companies on January 1, 1913, appointed four Market Agents to co-operate with producers and buyers for the successful marketing of agricultural and horticultural products from the territory adjacent to their lines. These agents neither buy nor sell, but it is their function to advise producers as to market opportunities and as to best methods of packing and shipping and to advise buyers as to where different varieties of products may be obtained. The services of these Agents are being availed of with substantial results.

#### Farm Settlers:

The Land and Industrial Department of the Company has continued and broadened its solicitation of farm settlers. The advantages which the

Southeast has to offer in climate and in lands that are relatively cheap in proportion to their productive value and the accessibility of markets are being more widely appreciated. The abundance of land available is indicated by the United States Census figures showing that, with a total land area of 264,058,880 acres, the nine Southeastern States had 169,174,373 acres, or 64 per cent. in farms, and the Census Bureau classes 82,831,384 acres or 48.9 per cent. of the land in farms, or 31.4 per cent. of the total land area, as "improved land in farms." The agricultural resources of the territory are such that it offers an attractive field for the farm settler from the more congested parts of the United States or for the men who have found conditions disappointing in other localities. The result is that there is an increasing movement of farm settlers into the territory along the Company's lines.

#### Manufacturing:

The advantages of the territory along the Company's lines for diversified manufacturing have led to continued development during the year. Special attention is being given to the location of industries which use as their raw materials the products of primary manufacturing and to attracting to the Southeast industries which have not heretofore been largely developed in that section.

The number of new industrial plants completed during the fiscal year at points on the Company's lines was 523, classified as follows:

Brick Works .....	37
Cotton Seed Oil Mills.....	20
Fertilizer Works .....	11
Flour and Feed Mills.....	26
Furniture Factories .....	14
Iron Industries .....	24
Lumber Mills .....	93
Stone Quarries, Coal and Other Mines.....	44
Tanneries .....	2
Textile Mills .....	37
Woodworking Plants .....	46
Miscellaneous .....	169
<b>Total .....</b>	<b>523</b>

The number of industrial plants under construction at the close of the year was 60, and the number of plants to which additions were made during the year was 222.

#### SERVICE OF EMPLOYEES.

It is a source of much pleasure to the Board to renew its expression of appreciation of the loyal and efficient service rendered during the year by officers and employees in all departments of the Company in the performance of their duties.

#### ACCOUNTS AND STATISTICS.

Statements of the accounts and statistics of the Company in the usual detail will be found in the tables hereto annexed.

The accounts have been examined, as usual, by Certified Public Accountants, Messrs. Patterson, Teele & Dennis, and their certificate is made a part of this report.

Respectfully submitted, by order of the Board,

W. W. FINLEY,  
President.

TABLE 1.  
INCOME STATEMENT FOR YEAR ENDED JUNE 30, 1913, COMPARED WITH YEAR ENDED JUNE 30, 1912.

1912.		1913.
	<b>OPERATING REVENUES:</b>	
\$41,508,300.38	Freight Revenue .....	\$44,943,747.82
16,939,811.36	Passenger Revenue .....	18,220,489.43
326,202.88	Miscellaneous Passenger-Train Revenue...	330,547.81
1,352,298.62	Mail Revenue .....	1,379,165.00
1,948,956.80	Express Revenue .....	2,008,008.99
876,357.79	Other Transportation Revenue.....	924,656.90
638,401.07	Revenue from Operations other than Transportation .....	722,874.25
<b>\$63,590,328.90</b>	<b>TOTAL OPERATING REVENUES.....</b>	<b>\$68,529,490.20</b>
	<b>OPERATING EXPENSES:</b>	
\$7,841,220.15	Maintenance of Way and Structures.....	\$9,275,553.17
10,108,672.84	Maintenance of Equipment .....	11,290,337.19
1,745,353.05	Traffic Expenses .....	2,094,009.69
22,081,653.47	Transportation Expenses .....	23,605,046.02
1,919,336.88	General Expenses .....	2,008,977.48
<b>\$43,696,236.39</b>	<b>TOTAL OPERATING EXPENSES.....</b>	<b>\$48,273,923.55</b>
<b>\$19,894,092.51</b>	<b>NET OPERATING REVENUE .....</b>	<b>\$20,255,566.65</b>
64,754.67	AUXILIARY OPERATIONS—NET REVENUE.....	80,535.87
<b>\$19,958,847.18</b>	<b>NET REVENUE .....</b>	<b>\$20,336,102.52</b>
2,452,328.28	TAXES .....	2,480,387.28
<b>\$17,506,518.90</b>	<b>OPERATING INCOME .....</b>	<b>\$17,855,715.24</b>
	<b>OTHER INCOME:</b>	
\$20,000.00	Rents from Lease of Roads.....	\$65,000.00
31,206.88	Hire of Equipment—Balance.....	5,072.83
208,394.38	Joint Facility Rent.....	210,696.09
112,517.35	Miscellaneous Rent .....	108,095.03
28,373.37	Net Income from Rail Leased.....	27,396.19

1912.		1913.		1912.		1913.
1,357,142.71	Dividends on Stocks.....	1,318,235.55			INTEREST ACCRUED ON FUNDED DEBT (See Table 2) .....	\$10,105,356.65
1,401,290.08	Interest on Bonds and Notes.....	1,390,490.35	\$10,204,481.66		INTEREST ACCRUED ON EQUIPMENT OBLIGATIONS (See Table 2).....	706,809.75
268,376.83	Interest on Unfunded Securities and Accounts .....	214,434.38	712,414.18		DIVIDENDS ACCRUED ON SOUTHERN RAILWAY—MOBILE AND OHIO STOCK TRUST CERTIFICATES .....	226,808.00
153,140.10	Miscellaneous Income .....	26,550.08	226,808.00		<b>BALANCE OF INCOME OVER CHARGES.....</b>	<b>\$7,078,625.17</b>
<b>\$3,580,441.70</b>	<b>TOTAL OTHER INCOME.....</b>	<b>\$3,365,970.50</b>	<b>226,808.00</b>		<b>FROM WHICH DEDUCT DIVIDENDS ON PREFERRED STOCK:</b>	
<b>\$21,086,960.60</b>	<b>TOTAL GROSS INCOME.....</b>	<b>\$21,221,685.74</b>	<b>\$11,143,703.84</b>		Nos. 23 (2%) and 25 (2½%) paid in April	\$1,500,000.00
	<b>DEDUCTIONS FROM TOTAL GROSS INCOME:</b>		<b>\$6,763,117.06</b>		No. 24 (2½%) paid in October, 1912, and Reserve for Dividend No. 26 (2½%), payable in October, 1913.....	1,500,000.00
	Income from Operation, Southern Railway Company in Mississippi, Alabama State Line to Columbus, Miss.....	\$48,213.72	\$1,200,000.00		<b>TOTAL DIVIDENDS .....</b>	<b>\$3,000,000.00</b>
\$50,950.88	Rents for Lease of Other Roads (See Table 2) .....	1,783,327.58	1,500,000.00		<b>BALANCE OVER DIVIDENDS ON PREFERRED STOCK APPROPRIATION OF INCOME FOR ADDITIONS AND BETTERMENTS .....</b>	<b>48,660.48</b>
1,865,927.33	Joint Facility Rent.....	969,219.82	\$2,700,000.00		<b>BALANCE CARRIED TO CREDIT OF PROFIT AND LOSS .....</b>	<b>\$4,029,964.69</b>
898,444.10	Miscellaneous Rent .....	35,920.74	\$4,063,117.06			
36,242.83	Separately Operated Properties.....	167,633.10	44,989.42			
180,701.01	Amortization of Discount on Funded Debt.....	12,017.04				
60,043.25	Interest on Unfunded Debt.....	244.56				
366.84	Miscellaneous Deductions .....	87,509.61				
87,463.46	<b>TOTAL DEDUCTIONS .....</b>	<b>\$3,104,086.17</b>				
<b>\$3,180,139.70</b>	<b>TOTAL AVAILABLE INCOME.....</b>	<b>\$18,117,599.57</b>	<b>\$4,018,127.64</b>			
<b>\$17,906,820.90</b>						

TABLE 4.  
GENERAL BALANCE SHEET, JUNE 30, 1913, AND JUNE 30, 1912.

JUNE 30, 1912.	PROPERTY INVESTMENT:	ASSETS.	JUNE 30, 1913.
\$287,434,900.33	ROAD AND EQUIPMENT:		
46,672,108.87	Investment to June 30, 1907:	Road .....	\$287,434,900.33
	Road .....	Equipment (Including Trust Equipment).....	46,672,108.87
\$334,107,009.20	Total Investment to June 30, 1907.....		\$334,107,009.20
	Investment since June 30, 1907:		
\$17,600,330.82	Road .....		\$20,528,069.86
18,241,339.68	Equipment (Including Trust Equipment).....		18,830,114.91
35,841,670.50	Total Investment since June 30, 1907.....		\$39,358,184.77
\$369,948,679.70	Total Road and Equipment.....		\$373,465,193.97
13,480,904.46	Less: Reserve for Accrued Depreciation on Equipment.....		14,321,746.67
\$356,467,775.24	Total Net Road and Equipment.....		\$359,143,447.30
	SECURITIES:		
\$2,487,686.26	Securities of Proprietary, Affiliated and Controlled Companies, Pledged:		
21,508,920.74	Stocks .....	\$2,487,586.26	
\$23,996,607.00	Bonds .....	21,508,920.74	\$23,996,507.00
2,000,000.00	Bonds Issued or Assumed, Pledged.....		2,000,000.00
\$116,887.21	Securities of Proprietary, Affiliated and Controlled Companies, Unpledged:		
684,418.75	Stocks .....	\$116,887.21	
801,305.96	Bonds .....	678,418.75	795,305.96
\$26,797,912.96	Total .....		\$26,791,812.96
	OTHER INVESTMENTS:		
\$419,193.34	Advances to Proprietary, Affiliated and Controlled Companies for Construction, Equipment and Betterments.....		\$408,234.86
	MISCELLANEOUS INVESTMENTS:		
\$355,590.67	Physical Property .....	\$401,844.24	
33,588,943.91	Securities, Pledged .....	33,640,943.91	
9,450,980.28	Securities, Unpledged .....	9,283,027.94	43,325,816.09
43,395,514.86	Total .....		\$43,734,050.95
\$43,814,708.20	WORKING ASSETS:		
\$13,048,782.30	Cash .....		\$8,295,928.23
22,331,800.00	Securities Issued or Assumed, Held in Treasury.....		27,148,800.00
\$256,522.00	Marketable Securities:		
179,059.04	Stocks .....	\$256,522.00	
51,455.00	Bonds .....	179,060.04	
487,036.04	Miscellaneous .....		435,582.04
448,483.55	Loans and Bills Receivable.....		398,402.85
762,026.42	Traffic and Car Service Balances due from other Companies.....		826,707.66
467,025.40	Balance due from Agents and Conductors.....		449,968.74
2,237,325.52	Miscellaneous Accounts Receivable.....		2,932,361.60
4,210,084.90	Material and Supplies (See Table 11).....		5,343,032.61
722,674.10	Other Working Assets.....		774,248.79
\$44,715,238.23	Total .....		\$46,605,032.52
\$1,062,490.26	ACCRUED INCOME NOT DUE:		
	Unmatured Interest, Dividends and Rents Receivable.....		\$962,243.79
\$730,882.15	DEFERRED DEBIT ITEMS:		
136,428.19	Temporary advances to Proprietary, Affiliated and Controlled Companies.....	\$695,737.86	
1,063,764.13	Working Funds .....	255,034.61	
2,046.61	Other Advances .....	986,782.28	
29,150.03	Insurance Premiums Paid in Advance.....	1,486.68	
2,923,331.19	Taxes Paid in Advance.....	29,089.11	
3,525.00	Special Deposits .....	2,718,164.33	
915,941.37	Cash and Securities in Sinking and Redemption Funds.....	39,298.80	
1,377,926.99	Cash and Securities in Insurance Reserve Fund.....	989,354.41	
7,182,995.66	Other Deferred Debit Items.....	1,432,770.97	
\$480,041,120.55	Total .....		7,147,719.05
	GRAND TOTAL .....		\$484,384,306.57

JUNE 30, 1912.		LIABILITIES.		JUNE 30, 1913.	
\$120,000,000.00		<b>CAPITAL STOCK:</b>			
60,000,000.00		Common .....		\$120,000,000.00	
		Preferred .....		60,000,000.00	
	\$180,000,000.00	Total .....			\$180,000,000.00
\$193,956,900.00		<b>MORTGAGE, BONDED AND SECURED DEBT:</b>			
24,539,800.00		Mortgage Bonds, Outstanding .....	\$195,276,300.00		
		Mortgage Bonds, Held by Company .....	29,356,800.00		
	\$218,496,700.00	Total .....		\$224,633,100.00	
\$19,738,700.00		Collateral Trust Bonds, Outstanding .....	\$19,790,700.00		
42,000.00		Collateral Trust Bonds, Held by Company .....	42,000.00		
	19,780,700.00	Total .....		19,832,700.00	
	10,107,000.00	Notes Outstanding .....		5,107,000.00	
	\$248,384,400.00	Total (See Table 5) .....		\$249,572,800.00	
	16,380,000.00	Equipment Trust Obligations (See Table 6) .....		15,146,000.00	
	\$264,764,400.00	Total .....			264,718,800.00
		<b>WORKING LIABILITIES:</b>			
\$455,000.00		Loans and Bills Payable .....	\$455,000.00		
817,608.07		Traffic and Car Service Balances due to other Companies .....	1,071,555.36		
5,984,377.17		Audited Vouchers, Accounts and Wages Unpaid .....	6,945,724.58		
344,295.59		Miscellaneous Accounts Payable .....	270,825.39		
2,880,202.44		Matured Interest, Dividends and Rents Unpaid, including amounts due July 1 .....	2,933,534.68		
3,400.00		Matured Mortgage, Bonded and Secured Debt Unpaid, not presented for Redemption .....	38,673.80		
1,635,256.55		Other Working Liabilities .....	1,949,702.92		
	12,120,139.82	Total .....			13,665,016.73
\$1,697,303.31		<b>ACCRUED LIABILITIES NOT DUE:</b>			
953,013.02		Unmatured Interest and Rents Payable .....	\$1,571,827.65		
		Taxes .....	982,398.61		
	2,650,316.33	Total .....			2,554,226.26
\$1,983,983.09		<b>DEFERRED CREDIT ITEMS:</b>			
1,987,903.27		Operating Reserves .....	\$1,286,086.33		
		Other Deferred Credit Items .....	1,886,103.62		
	3,971,886.36	Total .....			3,172,189.95
\$1,500,000.00		<b>APPROPRIATED SURPLUS:</b>			
361,500.54		Reserve for Dividends No. 24, 2½ Per Cent., and No. 26, 2½ Per Cent. on Preferred			
915,941.37		Stock, payable October, 1912 and 1913, respectively .....	\$1,500,000.00		
		Additions to Property since June 30, 1907, through Income .....	410,161.02		
		Insurance Reserve Fund .....	989,354.41		
	2,777,441.91	Total .....			2,899,515.43
	13,756,936.13	<b>PROFIT AND LOSS</b> .....			17,374,558.20
	\$480,041,120.55	<b>GRAND TOTAL</b> .....			\$484,384,306.57

Outstanding Securities on Leasehold Estates and the contra asset in Property Investment, heretofore shown, are eliminated from this Balance Sheet. See explanation Page 24 and Table 7.

TABLE 3.

PROFIT AND LOSS FOR YEAR ENDED JUNE 30, 1913.

Balance at Credit of this Account June 30, 1912 .....	\$13,756,936.13
Add:	
Credit Balance of Income for the Year .....	4,029,964.69
	\$17,786,900.82
Deduct:	
Discount on Securities charged off during the year .....	\$98,332.96
Value of Property Abandoned .....	58,711.25
Damages to Property occasioned by explosion of dynamite at Jellico, Tenn., September, 1906 .....	86,437.76
Advances to Delta Southern Railway written down .....	153,072.27
Net Miscellaneous Debits .....	15,788.38
	412,342.62
Credit Balance June 30, 1913 .....	\$17,374,558.20

TABLE 16.

TRAFFIC STATISTICS FOR YEARS ENDED JUNE 30, 1913, AND 1912.

	1913.	1912.	Per Cent. of Increase or Decrease.
Average Miles of Road Operated .....	7,035.61	7,088.03	Dec. .74
<b>PASSENGER TRAFFIC:</b>			
Number of Passengers Carried .....	19,032,397	18,119,253	Inc. 5.04
Number of Passengers Carried One Mile .....	844,801,198	786,621,787	Inc. 7.40
Average Distance Hauled per Passenger .....	44.39	43.41	Inc. 2.26
Total Revenue from Passengers .....	\$18,220,489.43	\$16,939,811.36	Inc. 7.56
Average Receipts per Passenger per Mile .....	2.157	2.153	Inc. .19
Total Passenger-Train Revenue .....	\$21,938,211.23	\$20,567,269.66	Inc. 6.67
Passenger-Train Revenue per Mile of Road .....	\$ 3,118.17	\$ 2,901.69	Inc. 7.46
Passenger-Train Revenue per Train Mile .....	\$ 1,193.35	\$ 1,155.10	Inc. 3.31
Average Number of Passengers in Each Train .....	45.95	44.18	Inc. 4.01
*Average Number of Passengers in Each Car .....	13.18	12.98	Inc. 1.54
<b>FREIGHT TRAFFIC:</b>			
Revenue Freight:			
Number of Tons Carried .....	29,449,589	27,214,751	Inc. 8.21
Number of Tons Carried One Mile .....	4,577,486,801	4,206,785,057	Inc. 8.81

	1913.	1912.	Per Cent. of Increase or Decrease.
Average Distance Hauled per Ton .....	155.43	154.58	Inc. .55
Total Freight-Train Revenue .....	\$44,943,747.82	\$41,508,300.38	Inc. 8.28
Average Receipts per Ton per Mile .....	0.982	0.987	Dec. .51
Freight-Train Revenue per Mile of Road .....	\$ 6,388.04	\$ 5,856.11	Inc. 9.08
Freight-Train Revenue per Train Mile .....	\$ 2,548.11	\$ 2,467.16	Inc. 3.28
Average Number of Tons of Freight in Each Train .....	259.52	250.04	Inc. 3.79
Average Number of Tons of Freight in Each Loaded Car .....	14.86	14.53	Inc. 2.27
<b>All Freight (Including Company's Material Hauled Free):</b>			
Number of Tons Carried .....	35,311,676	32,373,584	Inc. 9.08
Number of Tons Carried One Mile .....	5,658,038,364	5,202,609,293	Inc. 8.75
Number of Tons Carried One Mile per Mile of Road .....	804,200	733,999	Inc. 9.57
Average Number of Tons of Freight in Each Train .....	320.79	309.23	Inc. 3.74
Average Number of Tons of Freight in Each Loaded Car .....	18.36	17.97	Inc. 2.17
<b>REVENUES AND OPERATING EXPENSES:</b>			
Passenger and Freight-Train Revenue .....	\$66,881,959.05	\$62,075,570.04	Inc. 7.74
Passenger and Freight-Train Revenue per Mile of Road .....	\$ 9,506.21	\$ 8,757.80	Inc. 8.55
†Operating Revenues .....	\$68,529,490.20	\$63,590,328.90	Inc. 7.77
Operating Revenues per Mile of Road .....	\$ 9,740.38	\$ 8,971.51	Inc. 8.57
Operating Revenues per Revenue Train Mile .....	\$ 1,953.90	\$ 1,889.28	Inc. 3.42
†Operating Expenses (Taxes Excluded) .....	\$48,273,923.55	\$43,696,236.39	Inc. 10.48
Operating Expenses per Mile of Road .....	\$ 6,861.37	\$ 6,164.79	Inc. 11.30
Operating Expenses per Revenue Train Mile .....	\$ 1,376.38	\$ 1,298.22	Inc. 6.02
†Net Operating Revenue .....	\$20,255,566.65	\$19,894,092.51	Inc. 1.82
Net Operating Revenue per Mile of Road .....	\$ 2,879.01	\$ 2,806.72	Inc. 2.58
Net Operating Revenue per Revenue Train Mile .....	\$ 0.57752	\$ 0.59106	Dec. 2.29

\*Includes Sleeping, Parlor and Observation Cars.  
†Excludes Auxiliary Operations.

THE CHICAGO, ROCK ISLAND AND PACIFIC RAILWAY COMPANY.—THIRTY-THIRD ANNUAL REPORT.

FISCAL YEAR ENDED JUNE 30, 1913.

To the Stockholders:

The Board of Directors herewith submit their report of the operations and affairs of the Rock Island Lines for the fiscal year ended June 30, 1913. The results of the operations for the year were as follows:

Total operating revenue (increase \$6,652,081.74, or 10.3 per cent.)	\$71,364,935.06
Operating expenses (increase \$5,744,608.13 or 12.3 per cent.)	52,504,102.14
Net operating revenue (increase \$907,473.61, or 5.1 per cent.)	\$18,860,832.92
Taxes (increase \$153,122.50, or 5.5 per cent.)	2,946,437.54
Operating income	\$15,914,395.38
Miscellaneous income	1,029,794.99
Total income	\$16,944,190.37
Interest and rentals	12,885,835.53
Balance of income, after providing for all charges, being 5.4 per cent. on capital stock (\$75,000,000.00)	\$4,058,354.84
Dividends paid (5 per cent. on capital stock)	3,743,525.00
Balance surplus for the year	\$314,829.84

For comparative income account in detail, see table on page 13.

CAPITAL STOCK.

No change occurred in the capital stock outstanding during the year, it remaining the same as at the close of the previous fiscal year.

FUNDED DEBT.

The funded debt, not including equipment notes, compared with the previous fiscal year, shows a net increase of \$3,480,000.00, while the net increase in equipment notes was \$3,146,000.00, resulting in a total net increase in the funded debt of \$6,626,000.00.

For an analysis of the above, reference is made to pages 19 and 20.

ROAD AND EQUIPMENT.

Your Company increased its property investment during the year, \$9,537,861.86, which represents expenditures for additions and betterments, as well as the acquisition of additional equipment, including equipment purchased under car trust agreements.

Complete details are exhibited on pages 17 and 18.

NEW LINES ACQUIRED.

During the past year your Company acquired all the outstanding stock of the Rock Island, Stuttgart and Southern Railway Company, extending from Mesa, Arkansas, to Stuttgart, Arkansas, approximately twenty-two miles, through a well populated and prosperous agricultural community, rice being the principal commodity produced. The cost of this new line, together with additional terminal property acquired since its purchase, was \$168,737.42. The property is as yet separately operated; therefore none of its mileage, revenues, expenses or statistics are included in this report.

NEW EQUIPMENT.

All the undelivered equipment to which attention was directed in the previous report, was received and placed in service during the present fiscal year.

During the current fiscal year, your Company placed orders for 87 locomotives, 30 of which are of the Pacific type, 25 of the Mikado type, 2 of the Mountain type and 30 for use in switching service. Orders were also placed for 72 steel passenger train cars (4 of which are to be Express Horse Cars), 2,050 freight train cars and 2 wrecking cranes.

Of the above equipment, 30 locomotives and 2 passenger train cars have been delivered; the balance are to be delivered during the ensuing fiscal year.

Of the 1,106 cars in passenger service on June 30th, 1913, 276 or 25 per cent. were of solid steel construction. Of the total passenger train cars, exclusive of Pullman equipment, run in through main line trains, 51 per cent. were of solid steel construction, and of the total mileage made by passenger train cars, exclusive of Pullman equipment, during the year covered by this report 40 per cent. was made by cars of solid steel construction.

The detail of the changes during the year appear on pages 39, 41 and 42.

CONSTRUCTION OF NEW LINES.

That portion of the St. Paul and Kansas City Short Line Railroad between Carlisle, Iowa, and Allerton, Iowa, referred to in the two preceding reports as being under construction, was opened for local service July 2, 1913. Through passenger and freight train service was inaugurated September 14, 1913.

This line connects with that of your Company at Allerton, Iowa, for Kansas City, Missouri, and points south and southwest, and at Manly, Iowa, for the so-called Twin Cities of Minnesota and the Northwest. The intermediate connections with your Company at Des Moines, Iowa, and Iowa Falls, Iowa, afford an excellent outlet for traffic to and from East and West, as well as the advantage of interchanging traffic with several other trunk line systems at the above points.

Construction of the Malvern and Camden Railway (referred to in last year's report), extending from Malvern, Arkansas, to Camden, Arkansas, has been completed since the close of the fiscal year under review and it was opened for operation on October 1, 1913.

GENERAL.

The records maintained by the industrial department, show that there were located along the lines of your Company, during the fiscal year just ended, one hundred and forty-four new industries at an estimated cost for construction of over four million dollars. It is estimated that the operation of these industries will yield employment to over twenty-five hundred men and result in an annual movement of more than eighteen thousand carloads of revenue freight. Such industries will also produce a heavy volume of less than carload freight.

Industrial tracks were constructed to seventy-seven private industries and to six coal mines, necessitating the construction of eighty-three new tracks during the period for which this report is rendered. Additional track improvement was made in the way of re-arranging and extending tracks to fifteen industries. An expenditure of \$1,098,768.75 was made during the current fiscal year for the completion and erection of additional and improved terminal facilities.

In order that the Trinity and Brazos Valley Railway Company might

meet its payments for additions and betterments, equipment and operating deficit during the current fiscal year, your Company advanced one-half of the necessary funds, aggregating \$469,918.80.

During the year under review the Arkansas and Memphis Railway Bridge and Terminal Company was incorporated for the purpose of building a double track steel bridge across the Mississippi River at Memphis, Tennessee. Construction is now under way and this bridge when completed will be equally owned by The Chicago, Rock Island and Pacific Railway Company, St. Louis, Iron Mountain and Southern Railway and St. Louis Southwestern Railway Company, and when it is in operation the transfer charges of this Company at that point will be very materially reduced.

At the close of the year your Company was carrying on its pension rolls 155 superannuated employees and the expenses of the Pension Department during the year under review were \$54,762.24.

By order of the Board of Directors,  
H. U. MUDGE,  
President.

October 6, 1913.

INCOME ACCOUNT.

YEAR ENDED JUNE 30, 1913, COMPARED WITH PREVIOUS YEAR.

	1912-13.	1911-12.	Amount.	Per Cent.
Average mileage operated	8,048.07	8,035.84	12.23	15
<i>Revenue from transportation:</i>				
Freight	\$46,428,045.31	\$41,156,834.72	\$5,271,210.59	12.81
Passenger	19,777,430.86	18,609,408.36	1,168,022.50	6.28
Mail	1,611,311.99	1,602,209.29	9,102.70	.57
Express	2,055,123.03	2,014,386.03	40,737.00	2.02
Miscellaneous	981,093.46	873,417.38	107,676.08	12.33
Total transportation revenue	\$70,853,004.65	\$64,256,255.78	\$6,596,748.87	10.27
<i>Revenue from operations other than transportation:</i>				
Total operating revenue	\$71,364,935.06	\$64,712,853.32	\$6,652,081.74	10.28
<i>Operating expenses:</i>				
Maintenance of way and structures	\$9,885,323.86	\$8,493,345.86	\$1,391,978.00	16.39
Maintenance of equipment	10,072,854.15	8,302,466.70	1,770,387.45	21.32
Traffic expenses	1,999,138.20	1,981,398.97	17,739.23	.90
Transportation expenses	28,772,587.34	26,210,502.08	2,562,085.26	9.78
General expenses	1,774,198.59	1,771,780.40	2,418.19	.14
Total operating expenses	\$52,504,102.14	\$46,759,494.01	\$5,744,608.13	12.29
Net operating revenue	\$18,860,832.92	\$17,953,359.31	\$907,473.61	5.05
Taxes	2,946,437.54	2,793,315.04	153,122.50	5.48
Operating income	\$15,914,395.38	\$15,160,044.27	\$754,351.11	4.98
<i>Outside operations (debit balance):</i>				
Hire of equipment (debit balance)	\$191,577.32	\$196,976.63	\$5,399.31	2.74
Other income	867,856.82	990,827.67	122,970.85	12.41
Total	2,089,229.13	1,915,048.94	174,180.19	9.10
Total income	\$16,944,190.37	\$15,887,288.91	\$1,056,901.46	6.65
Interest	\$11,066,032.36	\$10,492,134.63	\$573,897.73	5.47
Rentals	1,819,803.17	1,544,758.36	275,044.81	17.81
Total charges	\$12,885,835.53	\$12,036,892.99	\$848,942.54	7.05
Balance of income (available for dividends)	\$4,058,354.84	\$3,850,395.92	\$207,958.92	5.40
Dividends	3,743,525.00	3,743,760.00	*235.00	*.01
Balance surplus (carried to credit of profit and loss)	\$314,829.84	\$106,635.92	\$208,193.92	195.24

\*Decrease.

DIVIDEND DECLARED DURING YEAR ENDED JUNE 30, 1913.

Dividend No. 129, 1 1/4 per cent. paid September 30, 1912	\$935,881.25
Dividend No. 130, 1 1/4 per cent. paid December 31, 1912	935,881.25
Dividend No. 131, 1 1/4 per cent. paid March 31, 1913	935,881.25
Dividend No. 132, 1 1/4 per cent. paid June 30, 1913	935,881.25

Total, 5 per cent. \$3,743,525.00

PROFIT AND LOSS.

Credit balance, June 30, 1912	\$14,598,083.97
Surplus for year ended June 30, 1913	\$314,829.84
Sundry adjustments not affecting current year's income, etc.	121,869.92
	\$436,699.76
<i>Less:</i>	
Loss on securities and land sold	\$847,652.02
Miscellaneous adjustments, etc.	62,235.43
	\$909,887.45
Depreciation on:	
Tracks removed	\$30,976.72
Structures sold, removed or destroyed	11,447.14
Equipment sold, dismantled or destroyed	477,621.29
	520,045.15
	1,429,932.60
	993,232.84
Credit balance, June 30, 1913	\$13,604,851.13



CONDENSED GENERAL BALANCE SHEET.  
JUNE 30, 1913, AND COMPARISON WITH PREVIOUS YEAR.

Assets.	1913.	1912.	INCREASE DECREASE.	LIABILITIES.	1913.	1912.	INCREASE DECREASE.
<b>Property Investments:</b>				<b>Stock:</b>			
<i>Road and Equipment:</i>				Capital stock.....	\$75,000,000.00	\$75,000,000.00	.....
Investment to June 30, 1907.....	\$255,585,343.24	\$255,585,343.24	.....	<i>Mortgage, bonded and secured debt:</i>			
Investment since June 30, 1907.....	41,148,338.63	31,610,476.77	\$9,537,861.86	Funded debt.....	257,815,600.00	251,189,600.00	\$6,626,000.00
Reserved for accrued depreciation—credit.....	755,302.30	609,043.31	—\$146,258.99	Total capital liabilities.....	\$332,815,600.00	\$326,189,600.00	\$6,626,000.00
Total road and equipment.....	\$295,978,379.57	\$286,586,776.70	\$9,391,602.87	<b>Working liabilities:</b>			
<b>Securities:</b>				Traffic and car-service balances due to other companies.....	\$1,249,335.10	\$917,345.51	\$331,989.59
Securities of proprietary affiliated and controlled companies—pledged....	604,321.24	180,233.16	424,088.08	Audited vouchers and wages unpaid.....	6,667,154.31	3,703,690.95	2,963,463.36
Securities issued or assumed—pledged.....	340,000.00	.....	340,000.00	Miscellaneous accounts payable.....	231,343.50	292,048.29	—60,704.79
Securities of proprietary, affiliated and controlled companies—unpledged.....	6,348,208.52	7,044,138.42	—\$695,929.90	Matured interest, dividends and rents unpaid.....	2,254,945.25	2,235,041.25	19,904.00
<b>Other investments:</b>				Matured mortgage, bonded and secured debt unpaid.....	23,000.00	23,000.00	.....
Advances to proprietary, affiliated and controlled companies for construction, equipment and betterments.....	10,606,449.33	8,873,117.75	1,733,331.58	Working advances due to other companies.....	241,052.32	190,620.30	50,432.02
Miscellaneous investments.....	2,418,868.70	2,471,175.52	—\$52,306.82	Other working liabilities..	1,092,808.88	1,002,748.53	90,060.35
Total property investment.....	\$316,296,227.36	\$305,155,441.55	\$11,140,785.81	Total working liabilities.....	\$11,759,639.36	\$8,364,494.83	\$3,395,144.53
<b>Working assets:</b>				<b>Accrued liabilities not due:</b>			
Cash.....	\$5,120,466.84	\$15,073,939.94	—\$9,953,473.10	Unmatured interest, dividends and rents payable.....	\$2,410,289.92	\$2,425,223.42	—\$14,933.50
Securities issued or assumed—held in treasury.....	5,033,458.23	557,458.23	4,476,000.00	Taxes accrued.....	1,313,030.07	1,317,869.45	—4,839.38
Marketable securities....	15,472,007.18	15,946,140.08	—474,132.90	Total accrued liabilities not due.....	\$3,723,319.99	\$3,743,092.87	—\$19,772.88
Loans and bills receivable.....	202,512.48	484,567.43	—282,054.95	<b>Deferred credit items:</b>			
Traffic and car-service balances due from other companies.....	943,713.90	652,253.82	291,460.08	Operating reserves.....	\$1,569,169.38	\$1,007,518.39	\$561,650.99
Net balance due from agents and conductors.....	1,085,143.39	1,058,584.79	26,558.60	Other deferred credit items.....	1,197,964.63	942,215.92	255,748.71
Miscellaneous accounts receivable.....	3,591,475.79	3,284,397.25	307,078.54	Total deferred credit items.....	\$2,767,134.01	\$1,949,734.31	\$817,399.70
Materials and supplies..	7,067,641.97	5,934,979.99	1,132,661.98	Grand total liabilities.....	\$351,065,693.36	\$340,246,922.01	\$10,818,771.35
Other working assets..	2,545,423.99	1,845,871.15	699,552.84	<b>Appropriated Surplus:</b>			
Total working assets.....	\$41,061,843.77	\$44,838,192.68	—\$3,776,348.91	Additions to property since June 30, 1907, through income.....	64,367.76	64,367.76	.....
<b>Accrued income not due:</b>				<b>Profit and loss:</b>			
Unmatured interest, dividends and rents receivable.....	\$913,464.34	\$656,656.94	\$256,807.40	Balance.....	13,604,851.13	14,598,083.97	—\$993,232.84
<b>Deferred debit items:</b>				Grand total.....	\$364,734,912.25	\$354,909,373.74	\$9,825,538.51
Advances.....	\$4,030,914.93	\$2,799,127.71	\$1,231,787.22				
Rents and insurance paid in advance.....	27,986.91	33,772.60	—\$5,785.69				
Special depositors.....	104,874.73	227,610.98	—122,736.25				
Other deferred debit items.....	2,299,600.21	1,198,571.28	1,101,028.93				
Total deferred debit items.....	\$6,463,376.78	\$4,259,082.57	\$2,204,294.21				
Grand total.....	\$364,734,912.25	\$354,909,373.74	\$9,825,538.51				

NOTE—In stating the assets and liabilities of the companies forming the Rock Island Lines, the holdings of The Chicago, Rock Island and Pacific Railway Company in the bonds and capital stock of the auxiliary lines, together with loans between the various companies, have been eliminated

from the liabilities and a like reduction made in the assets pertaining thereto; the figures shown, therefore, represent the book value of the assets and the liabilities without duplication.

ROAD AND EQUIPMENT—INVESTMENT SINCE JUNE 30, 1907.		
CHANGES DURING YEAR ENDED JUNE 30, 1913.		
Balance, June 30, 1912, as per balance sheet, page 14.....		\$31,610,476.77
CHANGES DURING THE YEAR:		
<b>Additions:</b>		
Additions and betterments, current year (not including equipment), see page 18.....	\$3,143,778.53	
<b>Expenditures for additional and improved equipment:</b>		
Purchase of 175 ballast cars.....	\$190,743.40	
Purchase of 10 automatic air dump cars.....	23,824.40	
Converting dining cars 1646 and 1647 into parlor cars.....	4,477.43	
Converting mail cars 1535 and 1544 into air-brake instruction cars.....	1,034.59	
Converting 6 flat cars into bank levelers.....	1,686.30	
New appliances for existing equipment, required by federal and state laws.....	82,685.39	
Miscellaneous and inspection charges in connection with purchase of business steel car No. 1911....	425.00	
Other new appliances for existing equipment.....	27,807.69	332,684.20
Total additions and betterments, as per page 18.....	\$3,476,462.73	

Disbursements for construction of Malvern and Camden Railway (property of Rock Island, Arkansas and Louisiana Railroad Company). Purchase of equipment to take the place of that destroyed which, under mortgages and equipment trust agreements, must be replaced.....	898,597.94	
Bankers Trust Company of New York, equipment purchase under indenture of July 1, 1912.....	5,419,941.51	
Additions and betterments on leased lines.....	2,902.45	
Net amount of miscellaneous adjustments covering equipment purchased under car trust agreements, prior to the current fiscal year..	16,240.01	
	\$10,287,665.24	

**Deductions:**

Value of equipment destroyed, dismantled or sold during the past fiscal year (exclusive of equipment which, under mortgages or equipment trust agreements, must be replaced). Such value, less salvage, was charged to operating expenses and profit and loss.....	\$632,481.49	
Reduction in book value, from par to actual cost, of The Chicago, Rock Island and Gulf Railway Company's first mortgage Amarillo Division bonds, such reduction being charged to profit and loss.....	117,321.89	749,803.38

Net increase..... 9,537,861.86

Balance, June 30, 1913, as per balance sheet, page 14.. \$41,148,338.63

EXPENDITURES FOR ADDITIONS AND BETTERMENTS.

YEAR ENDED JUNE 30, 1913.

Right of way and station grounds.....	\$ 111,354.22	
Real estate .....	21,238.26	
Widening cuts and fills.....	144,437.58	
Protection of banks .....	25,336.93	
Grade revisions and changes of line.....	8,128.69	
Bridges, trestles and culverts.....	253,676.26	
Increased weight of rail.....	114,896.34	
Improved frogs and switches.....	9,235.28	
Track fastenings and other material.....	214,906.05	
Ballast .....	590,068.11	
Sidings and spur tracks .....	168,146.51	
Terminal yards .....	71,902.70	
Fencing right of way.....	16,089.92	
Improvement of over and under grade crossings	4,230.85	
Track elevation, elimination of grade crossings,		
etc. ....	318,995.11	
Interlocking apparatus .....	18,057.13	
Block and other signal apparatus.....	44,806.32	
Telegraph and telephone lines.....	7,938.95	
Station buildings and fixtures.....	360,803.93	
Shops, engine houses and turn tables.....	110,296.80	
Shop machinery and tools.....	22,994.00	
Water and fuel stations.....	88,547.57	
Grain elevators and storage warehouses.....	371,079.85	
Dock and wharf property.....	103.99	
Electric light and power plants.....	183.02	
Electric power transmission .....	3,181.58	
Snow and sand fences and snow sheds.....	6,093.56	
Miscellaneous structures .....	6,498.04	
Interest and commissions .....	28,125.00	\$3,143,778.53

\*Equipment:

Steam locomotives .....	\$ 26,946.54	
Passenger train cars .....	20,312.09	
Freight train cars .....	67,109.94	
Work equipment .....	218,315.63	332,684.20
<b>Total additions and betterments.....</b>		<b>\$3,476,462.73</b>

The above amount was expended by the following companies:

The Chicago, Rock Island & Pacific Railway		
Company .....	\$3,392,397.27	
The Chicago, Rock Island and Gulf Railway		
Company .....	47,459.53	
Rock Island, Arkansas and Louisiana Rail-		
road Company .....	36,605.93	\$3,476,462.73

Expenditures for additions and betterments were also made by the following subsidiary companies:

Rock Island Improvement Company.....	\$ 56,038.67	
Keokuk and Des Moines Railway Company		
(leased line) .....	2,902.45	58,941.12

Total expenditures by all companies during the year.. \$3,535,403.85

\*Also described on page 17.  
Figures in italics denote credits.

MAINTENANCE OF WAY AND STRUCTURES—REMARKS.

YEAR ENDED JUNE 30, 1913.

COMPARATIVE STATEMENTS OF RAIL AND BALLAST IN MAIN AND BRANCH LINES OWNED OR LEASED AS OF JUNE 30, 1912 AND 1913.

	RAIL	TOTAL MILES OWNED OR LEASED	WEIGHT PER YARD AND MILES OF EACH WEIGHT.										
			100	85-90	80	Re-rolled 80	70	65-6-7-8	60	56-8	52 and under		
<b>1913 MAIN LINES</b>													
First track .....		*4,418.65	161.73	†1,250.02	1,801.73	284.53	36.37	575.87	308.40				
Second track .....		267.28	51.24	142.63	72.76	.65							
Third track .....		8.01			1.40	6.61							
Total .....		4,693.94	212.97	1,392.65	1,875.89	284.53	43.63	575.87	308.40				
Per cent. of main lines.....			4.54	29.87	39.96	6.06	.93	12.27	6.57				
<b>1912 MAIN LINES</b>													
First track .....		*4,418.71	70.98	1,229.86	1,886.98	246.63	36.37	607.76	340.13				
Second track .....		267.34	36.43	148.94	78.04	3.93							
Third track .....		8.01			1.31	6.70							
Total .....		4,694.06	107.41	1,378.80	1,966.33	246.63	47.00	607.76	340.13				
Per cent. of main lines.....			2.29	29.37	41.89	5.25	1.00	12.95	7.25				
<b>1913 BRANCH LINES</b>													
First track .....		3,002.43		†32.44	269.00	51.43	329.84	304.97	1,182.40	575.73	256.62		
Second track .....		14.90		5.02	1.83		.16		7.89				
Total .....		3,017.33		37.46	270.83	51.43	330.00	304.97	1,190.29	575.73	256.62		
Per cent. of branch lines.....				1.24	8.98	1.70	10.94	10.11	39.45	19.08	8.50		
<b>1912 BRANCH LINES</b>													
First track .....		3,002.54		24.74	268.27	37.65	338.91	304.84	1,184.75	580.42	262.96		
Second track .....		14.90		5.02	1.83		.16		7.89				
Total .....		3,017.44		29.76	270.10	37.65	339.07	304.84	1,192.64	580.42	262.96		
Per cent. of branch lines.....				.99	8.95	1.25	11.24	10.10	39.52	19.24	8.71		
<b>1913 Total</b>													
Per cent. of total track.....		7,711.27	212.97	1,430.11	2,146.72	335.96	373.63	880.84	1,498.69	575.73	256.62		
Per cent. of total track.....			2.76	18.55	27.83	4.36	4.85	11.42	19.43	7.47	3.33		
<b>1912 Total</b>													
Per cent. of total track.....		7,711.50	107.41	1,408.56	2,236.43	284.28	386.07	912.60	1,532.77	580.42	262.96		
Per cent. of total track.....			1.39	18.27	29.00	3.69	5.00	11.83	19.88	7.53	3.41		

	BALLAST	TOTAL MILES OWNED OR LEASED	KIND OF BALLAST AND MILES OF EACH KIND				SAND OR DIRT	
			Rock	Burned Clay	Gravel	Cinder		
<b>1913 MAIN LINES</b>								
First track .....		*4,418.65	1,406.87	587.62	1,534.52	315.48	3,844.49	574.16
Second track .....		267.28	22.14		218.88	23.26	264.28	3.00
Third track .....		8.01	.25		.39	7.37	8.01	
Total .....		4,693.94	1,429.26	587.62	1,753.79	346.11	4,116.78	577.16
Per cent. of main lines.....			30.45	12.52	37.36	7.37	87.70	12.30
<b>1912 MAIN LINES</b>								
First track .....		*4,418.71	1,371.45	565.37	1,435.33	318.04	3,690.19	728.52
Second track .....		267.34	17.26		219.28	27.80	264.34	3.00
Third track .....		8.01			.39	7.62	8.01	
Total .....		4,694.06	1,388.71	565.37	1,655.00	353.46	3,962.54	731.52
Per cent. of main lines.....			29.58	12.05	35.26	7.53	84.42	15.58
<b>1913 BRANCH LINES</b>								
First track .....		3,002.43	117.75	35.16	659.61	265.76	1,078.28	1,924.15
Second track .....		14.90			.50	14.40	14.90	
Total .....		3,017.33	117.75	35.16	660.11	280.16	1,093.18	1,924.15
Per cent. of branch lines.....			3.90	1.17	21.88	9.28	36.23	63.77
<b>1912 BRANCH LINES</b>								
First track .....		3,002.54	115.00	35.16	656.46	266.04	1,072.66	1,929.88
Second track .....		14.90			.50	14.40	14.90	
Total .....		3,017.44	115.00	35.16	656.96	280.44	1,087.56	1,929.88
Per cent. of branch lines.....			3.81	1.17	21.77	9.29	36.04	63.96
<b>1913 Total</b>								
Per cent. of total track.....		7,711.27	1,547.01	622.78	2,413.90	626.27	5,209.96	2,501.31
Per cent. of total track.....			20.06	8.08	31.30	8.12	67.56	32.44
<b>1912 Total</b>								
Per cent. of total track.....		7,711.50	1,503.71	600.53	2,311.96	633.90	5,050.10	2,661.40
Per cent. of total track.....			19.50	7.78	29.98	8.22	65.48	34.52

\*See statement on next page, showing the miles which are classified as "Main lines."  
†Includes 24.53 miles of main line and 7.70 miles of branch line of 90 pound rail.

MAINTENANCE OF WAY AND STRUCTURES—REMARKS,  
YEAR ENDED JUNE 30, 1913.

The following is a comparative statement of miles of the first track main lines (as distinguished from branch lines) owned or leased, not including trackage rights, which are used in the rail and ballast tables on preceding page:

	JUNE 30	
	1913	1912
Chicago, Ill., to Colorado Springs, Colo.....	1,063.03	1,063.09
Davenport, Ia., to Dallas, Tex. (via Kansas City).....	833.61	833.61
Herington, Kan., to Santa Rosa, N. M.....	526.92	526.92
Burlington, Ia., to Minneapolis, Minn.....	307.58	307.58
Altamont, Mo., to North Topeka, Kan. (via St. Joseph).....	137.91	137.91
McFarland, Kan., to Belleville, Kan.....	103.19	103.19
Memphis, Tenn., to Tucumcari, N. M.....	869.87	869.87
Biddle, Ark., to Eunice, La.....	292.64	292.64
St. Louis, Mo., to Kansas City, Mo.....	283.90	283.90
	4,418.65	4,418.71

Improvements to roadway have been made as follows:

Ties were renewed to the extent of 2,507,784, or an average of 328 per mile of first, second and third main track owned and leased; of these ties, 2,027,917 were treated with creosote.

Track miles of new ballast.....	159.86 miles
Track miles rebalasted.....	143.55 miles
Miles of roadbed widened to standard width.....	188.01 miles
Road miles of new right of way fence built.....	77.34 miles
Linear feet, transversely to track, of concrete arch culverts built.....	2,952 feet
Linear feet, transversely to track, of iron pipe culverts built.....	2,997 feet
Linear feet, transversely to track, of vitrified pipe culverts built.....	257 feet
Linear feet of timber bridges or trestles replaced with steel, concrete or masonry bridges.....	1,095 feet
Linear feet of bridges and trestles filled.....	5,155 feet
Linear feet of iron or steel bridges replaced with heavier structures.....	1,728 feet
Linear feet of new pile trestles built.....	534 feet
Linear feet of new steel bridges built.....	74 feet

The following table shows the aggregate length and nature of bridges at June 30, 1913, compared with previous year:

BRIDGES	TOTAL (FEET)	KIND OF BRIDGE AND LENGTH (IN FEET) OF EACH KIND				
		Steel and iron	Combination (wood and masonry)	Wooden	Trestles	
Main track, June 30, 1913.....	502,680	150,883	891	900	2,199	347,807
Per cent. of total length.....		30.01	.18	.18	.44	69.19
Main track, June 30, 1912.....	506,048	151,123	891	912	2,282	350,840
Per cent. of total length.....		29.86	.18	.18	.45	69.33

The average expense of maintenance of way and structures per mile of first, second and third main track owned and leased during the past fiscal year was \$1,229.04 as against \$1,072.10 last year.

The average expense of maintenance of way and structures per mile of first main track owned and leased for the fiscal year ended June 30, 1913, was \$1,277.48, compared with \$1,114.40 for the previous year.

All the rail relaid during the year has replaced lighter weight, and a corresponding increase in metal has been made in appliances.

FREIGHT TRAFFIC STATISTICS.

YEAR ENDED JUNE 30, 1913, COMPARED WITH PREVIOUS YEAR.

	1912-13	1911-12	INCREASE OR DECREASE
Revenue per ton mile.....	\$ .0089	\$ .0089	
Revenue per ton.....	\$ 2.200	\$ 2.170	\$.030
Revenue per train mile.....	\$ 2.651	\$ 2.486	\$.165
Revenue per car mile (excludes caboose car miles).....	\$ .1024	\$ .0969	\$.0055
Revenue per mile of road.....	\$5,768.84	\$5,121.66	\$647.18
Number of tons per train mile—revenue freight.....	297.17	277.81	19.36
Number of tons per train mile—company freight.....	59.29	51.97	7.32
Number of tons per train mile—all freight.....	356.46	329.78	26.68
Number of tons per loaded car mile—revenue freight.....	15.79	15.11	.68
Number of tons per loaded car mile—company freight.....	3.15	2.83	.32
Number of tons per loaded car mile—all freight.....	18.94	17.94	1.00
Number of tons per loaded and empty car mile—revenue freight.....	11.47	10.83	.64
Number of tons per loaded and empty car mile—company freight.....	2.29	2.03	.26
Number of tons per loaded and empty car mile—all freight.....	13.76	12.86	.90
Number of cars per train—loaded.....	18.82	18.36	.46
Number of cars per train—empty.....	7.07	7.25	-.18
Number of cars per train—all.....	25.89	25.61	.28
Average haul per ton—revenue freight (in miles).....	246.61	242.46	4.15

Average haul per ton—company freight (in miles).....	155.65	135.64	20.91
Average haul per ton—all freight (in miles).....	224.76	215.69	9.07
Average ton miles of revenue freight per mile operated.....	646,611	572,340	74,271

PASSENGER TRAFFIC AND PER MILE OF ROAD STATISTICS.  
YEAR ENDED JUNE 30, 1913, COMPARED WITH PREVIOUS YEAR.

	1912-13	1911-12	INCREASE OR DECREASE
PASSENGER TRAFFIC:			
Revenue per passenger mile.....	\$ .0201	\$ .0198	\$.0003
Revenue per passenger.....	\$ 1.018	\$ .983	\$.035
Revenue per train mile (excluding mail, express, etc.).....	\$ 1.013	\$ .975	\$.038
Revenue per train mile (including mail, express, etc.).....	\$ 1.214	\$ 1.179	\$.035
Revenue per car mile (cars carrying passengers).....	\$ .275	\$ .261	\$.014
Revenue per mile of road (excluding mail, express, etc.).....	\$2,457.41	\$2,315.80	\$141.61
Revenue per mile of road (including mail, express, etc.).....	\$2,945.38	\$2,802.16	\$143.22
Number of passengers per train mile.....	50.38	49.21	1.17
Number of passengers per car mile (cars carrying passengers).....	13.70	13.16	.54
Average distance carried (in miles).....	50.67	49.63	1.04
Number of cars per train.....	5.24	5.28	-.04
Average miles of revenue passengers per mile operated.....	122,228	116,900	5,328
PER MILE OF ROAD:			
Total operating revenue.....	\$8,867.33	\$8,053.03	\$814.30
Operating expenses.....	6,523.81	5,818.87	704.94
Net operating revenue.....	\$2,343.52	\$2,234.16	\$109.36
Taxes.....	366.10	347.61	18.49
Operating income.....	\$1,977.42	\$1,886.55	\$90.87
Outside operations (debit balance).....	23.80	24.51	.71
Hire of equipment (debit balance).....	107.83	123.30	15.47
Other income.....	259.59	238.32	21.27
Total income.....	\$2,105.38	\$1,977.06	\$128.32
Interest.....	\$1,374.99	\$1,305.67	\$69.32
Rentals.....	226.11	192.23	33.88
Total charges.....	\$1,601.10	\$1,497.90	\$103.20
Balance of income (available for dividends).....	\$ 504.28	\$ 479.16	\$ 25.12

MILEAGE AND TRAFFIC STATISTICS.  
YEAR ENDED JUNE 30, 1913, COMPARED WITH PREVIOUS YEAR.

	1912-13.	1911-12.	INCREASE OR DECREASE
Average miles of road operated.....	8,048.07	8,035.84	12.23
Miles of road operated June 30.....	8,048.14	8,041.66	6.48
Freight train miles.....	16,761,671	15,827,359	934,312
Passenger train miles.....	18,775,070	18,360,282	414,788
Mixed train miles.....	749,876	728,074	21,802
Special train miles.....	35,654	28,188	7,466
Total revenue train miles.....	36,322,271	34,943,903	1,378,368
Non-revenue service train miles.....	1,198,768	764,911	433,857
Total train miles.....	37,521,039	35,708,814	1,812,225
Loaded freight car miles.....	329,524,850	304,348,818	25,176,032
Empty freight car miles (excludes caboose car miles).....	123,795,711	120,205,068	3,590,643
Total freight car miles (excludes caboose car miles).....	453,320,561	424,553,886	28,766,675
Caboose car miles.....	16,389,774	15,744,038	645,736
Grand total freight car miles.....	469,710,335	440,297,924	29,412,411
Passenger car miles (including baggage, mail and express).....	102,218,799	100,853,000	1,365,799
Passenger car miles (carrying passengers).....	71,803,749	71,363,800	439,949
Number of tons moved—revenue freight.....	21,101,989	18,969,200	2,132,789
Number of tons moved—company freight.....	6,671,134	6,343,300	327,834
Number of tons moved—all freight.....	27,773,123	25,312,500	2,460,623
Number of tons moved one mile—revenue freight.....	5,203,973,087	4,599,247,000	604,726,087
Number of tons moved one mile—company freight.....	1,038,345,549	860,380,000	177,965,549
Number of tons moved one mile—all freight.....	6,242,318,636	5,459,627,000	782,691,636
Number of passengers carried.....	19,412,671	18,927,146	485,525
Number of passengers carried one mile.....	993.6*6,182	939,391,981	44,304,201

THE MISSOURI PACIFIC RAILWAY COMPANY.

St. Louis, Mo., September 10th, 1913.

To the Stockholders of

THE MISSOURI PACIFIC RAILWAY COMPANY AND THE ST. LOUIS, IRON MOUNTAIN & SOUTHERN RAILWAY COMPANY: The Boards of Directors herewith submit their report of affairs for the fiscal year ended June 30, 1913. The summary of results from operation is as follows:

	1913.	1912.	Increase or Decrease.	
			Amount.	Per Cent.
Average mileage Operated	7,257.00	7,230.77	26.23	.36
<b>RAILWAY OPERATING INCOME:</b>				
<b>RAIL OPERATIONS—</b>				
<b>REVENUE:</b>				
Freight	\$45,748,269.39	\$39,514,355.87	\$6,233,913.52	15.78
Passenger	11,627,480.60	10,662,443.17	965,037.43	9.05
Passenger—Other	199,628.55	196,006.14	3,622.41	1.85
Mail	1,450,607.97	1,429,607.72	21,000.25	1.47
Express	1,711,305.35	1,374,454.41	336,850.94	24.51
Miscellaneous	934,168.02	891,224.79	42,943.23	4.82
Total Revenue from Transportation	\$61,671,459.88	\$54,068,092.10	\$7,603,367.78	14.06
Nontransportation Revenue	484,046.26	435,157.82	48,888.44	11.23
Total Operating Revenues	\$62,155,506.14	\$54,503,249.92	\$7,652,256.22	14.04
<b>RAIL OPERATIONS—</b>				
<b>EXPENSES:</b>				
Maintenance of Way and Structures	\$ 9,263,360.32	\$ 8,664,769.03	\$ 598,591.29	6.91
Maintenance of Equipment	9,860,187.54	8,321,786.50	1,538,401.04	18.49
Traffic Expenses	1,425,167.92	1,358,014.19	67,153.73	4.94
Transportation Expenses	22,528,447.44	21,268,313.87	1,260,133.57	5.92
General Expenses	1,621,833.83	1,667,708.42	—45,874.59	2.75
Total Operating Expenses	\$44,698,997.05	\$41,280,592.01	\$3,418,405.04	8.28
Net Revenues—Rail Operations	\$17,456,509.09	\$13,222,657.91	\$4,233,851.18	32.02
Net Deficit from Auxiliary Operations	93,004.62	120,852.76	—27,848.14	23.04
Net Railway Operating Revenue	\$17,363,504.47	\$13,101,805.15	\$4,261,699.32	32.53
RAILWAY TAX ACCRUALS	\$ 2,314,348.73	\$ 2,218,018.40	\$ 96,330.33	4.34
Railway Operating Income	\$15,049,155.74	\$10,883,786.75	\$4,165,368.99	38.27
<b>OTHER INCOME:</b>				
Rent	\$ 519,527.98	\$ 491,823.20	\$ 27,704.78	5.63
Dividends from Stock	78,751.50	315,466.00	—236,714.50	75.04
Interest	1,833,771.35	1,355,708.75	478,062.60	35.26
Miscellaneous Income	31,548.07	83,647.51	—52,099.44	62.28
Total Other Income	\$ 2,463,598.90	\$ 2,246,645.46	\$ 216,953.44	9.66
Gross Income	\$17,512,754.64	\$13,130,432.21	\$4,382,322.43	33.38
<b>DEDUCTIONS FROM GROSS INCOME:</b>				
Rent	\$ 998,580.08	\$ 882,749.53	\$ 115,830.55	13.12
Equipment Rights—Debit Balance	477,240.27	746,367.21	—269,126.94	36.06
Interest	14,408,124.59	13,436,313.58	971,811.01	7.23
Miscellaneous Deductions	66,075.82	44,093.38	21,982.44	49.85
Total Deductions	\$15,950,020.76	\$15,109,523.70	\$ 840,497.06	5.56
Net Income or Loss	\$ 1,562,733.88	Def. \$1,979,091.49	\$3,541,825.37	
Operating Revenue per mile of road	\$ 8,564.90	\$ 7,537.68	\$1,027.22	13.63
Operating Revenue per revenue train mile	2.23867	2.07466	.16401	7.91
Operating Expense per mile of road	6,159.43	5,709.02	450.41	7.89
Operating Expense per revenue train mile	1.60993	1.57134	.03859	2.46
Net Operating Revenue per mile of road	2,405.47	1,828.66	576.81	31.54
Net Operating Revenue per revenue train mile	.62874	.50332	.12542	24.92
Ratio of Operating Expense to Operating Revenue	71.91%	75.74%	—3.83%	

For comparative purposes, the figures for the year ended June 30th, 1912, have been revised to compare with the present year, and to agree with the Classification of the Interstate Commerce Commission.

CAPITAL STOCK.

There has been no change in the capital stock during the year.

FUNDED DEBT.

The following changes were effected in the funded debt in hands of the public during the year:

THE MISSOURI PACIFIC RAILWAY COMPANY—  
 Funded Debt decreased .....\$ 24,000.00  
 Equipment Trust Obligations decreased..... 1,437,000.00

TOTAL DECREASE ..... \$1,461,000.00

ST. LOUIS, IRON MOUNTAIN & SOUTHERN RAILWAY COMPANY—  
 Funded Debt increased .....\$5,542,095.00  
 Equipment Trust Obligations decreased..... 1,213,000.00

TOTAL INCREASE ..... \$4,329,095.00

Statements on pages 21 and 27 give in detail the changes in these obligations.

The St. Louis, Iron Mountain & Southern Railway Company has purchased and retired the remaining bonds outstanding in the hands of the public under its First Preferred Income Consolidated Mortgage, amounting to \$37,905.

The St. Louis, Iron Mountain & Southern Railway Company also retired, during the year, \$11,300,000, being all of the outstanding bonds issued under its Improvement Mortgage and the three-year note payable to The Missouri Pacific Railway Company, amounting to \$8,500,000. The Improvement Mortgage has been satisfied of record and cancelled, and the note has been likewise cancelled.

The same amount (\$11,300,000) of the outstanding Missouri Pacific Railway Company's First and Refunding Bonds were simultaneously surrendered, and the right to issue an additional \$13,700,000 of said Refunding Bonds against a like amount of Improvement Bonds, was cancelled, by the satisfaction of record of the Improvement Mortgage.

The St. Louis, Iron Mountain & Southern Railway Company has executed an indenture to Union Trust Company of New York and Benjamin F. Edwards, as Trustees, dated June 1st, 1913, supplemental to its First and Refunding Mortgage to the same Trustees, dated July 1st, 1912. This supplemental indenture provides, among other things, for the creation of a sinking fund, to be made up of one-third of the Company's net income (after deducting an amount sufficient to pay a dividend of 4 per cent upon its outstanding capital stock), which is to be paid into the sinking fund annually on and after September 30th, 1915, such amount, however, being limited to \$1,000,000 in any one year, which said sinking fund is to be used for the purchase for cancellation, or for the redemption of bonds at any time outstanding under said refunding mortgage and supplemental indenture.

Certain changes have been made in the collateral securing the three-year 5 per cent gold notes, due June 1st, 1914, in accordance with the provisions of the indenture securing them, and there is at present pledged for the security of these notes, of which \$24,976,000 are outstanding, the following collateral:

- \$22,000,000 face value, St. Louis, Iron Mountain & Southern Railway Company 6 Per Cent Forty-Year Gold Bonds, Series "A" (non-convertible), due July 1st, 1952, secured by the first and refunding mortgage and indenture supplemental thereto;
- 1,070,000 par value (10,700 shares), St. Louis, Iron Mountain & Southern Railway Company Stock;
- 1,972,000 face value, The Missouri Pacific Railway Company First and Refunding Mortgage Fifty-Year 5 Per Cent Gold Bonds, Series "B" (non-convertible), due September 1st, 1959;
- 9,800,000 par value (98,000 shares), The Denver & Rio Grande Railroad Company Preferred Stock;
- 15,000,000 par value (150,000 shares), The Denver & Rio Grande Railroad Company Common Stock;
- 828,380 face value, The Texas & Pacific Railway Company 5 Per Cent Gold Note, due June 1st, 1914;
- 525,000 face value, Concordia Coal Company First Mortgage 5 Per Cent Bonds, due October 1st, 1945;
- 150,000 par value (1,500 shares), Baring Cross Bridge Company 7 Per Cent Stock;
- 125,000 par value (1,250 shares), Pueblo Stock Yards Company Stock;
- 1,000,000 par value (10,000 shares), Western Coal and Mining Company Stock.

NEW LINES.

The line between Marianna and West Memphis, Ark. (42.9 miles), referred to in last year's report, was placed in operation February 1st, 1913.

The lines of railway of the  
 Marion & Johnston City Railway Company..... 6.99 miles  
 Marion & Harrisburg Railway Company..... 1.97 miles  
 Johnston City Connecting Railway Company..... 2.05 miles

11.01 miles

located in the Southern Illinois Coal District, the entire capital stock of which was owned by the St. Louis, Iron Mountain & Southern Railway Company, were transferred to the latter by deed, thereby eliminating any necessity for continuing the separate corporate entity of each.

Detail of changes in mileage operated are retorded on page 51.

EQUIPMENT.

The following new equipment was purchased or built at Company's shops, and taken into the accounts, at cost of \$65,046.80:

- 1 Wrecking Crane 120 tons capacity,
- 2 Clam Shell Locomotive Cranes 25 tons capacity,
- 1 Steam Shovel,
- 5 Snow Plows,
- 1 Lidgerwood Unloader,
- 2 Scale Test Cars,
- 2 Yard Cranes,
- 1 Caboose.

The purchase of additional equipment was authorized and ordered, but delivery not made at close of year, as follows:

- 7 Mountain Type Locomotives,
- 5 Pacific Type Locomotives,
- 5 Mikado Type Locomotives,
- 2 Pile Drivers,
- 1 Bridge Erecting Derrick Car.

Comparisons of inventory and capacity of equipment appear in statements on pages 46 and 47.

ADDITIONS AND BETTERMENTS.

Except for right of way and station grounds and similar necessities, total amount involved approximately \$30,000, there were no realty acquisitions.

Cuts and Fills were widened to standard section on 650.54 miles, the major portion of it being essential in connection with necessary ballasting which was applied as follows:

Gravel .....	209.42 miles
Rock .....	.90 miles
Cinders and Slag.....	167.46 miles
Chatts .....	338.65 miles
<b>Total .....</b>	<b>716.43 miles</b>

It was not only expedient but necessary to continue this class of work urged as it has been by increases in traffic density. The amount thus expended, exclusive of maintenance charges, aggregated \$1,978,768.26.

Except for completion of the revision between Gorham and Bush, Ill., and a number of small raises of track on account of bridges or drainage, there were no expenditures for grade reductions or changes of line.

New 90-lb. section rail was laid on 261.82 miles in displacement of lighter sections.

Additional second tracks were constructed:	
West Side Junction to South Omaha.....	2.29 miles
West Side Junction to 29th Street, Omaha.....	2.59 miles
<b>Total .....</b>	<b>4.88 miles</b>

Sidings and spur tracks, and terminal yards were newly constructed or extended at a large number of points, increasing the track mileage 67.71 miles.

Fencing right of way has been continued and 481.8 miles completed during the year; in conjunction therewith 2,493 cattle guards were installed.

There were expended over \$56,000 in improvement and elimination of grade crossings, and installation of three interlocking plants.

Additional automatic block signals have been provided covering 9.73 track miles, and the necessary equipment has been added to telephone and telegraph lines to enable the extension of the Manual telephone block protection over 781.49 additional operated miles.

Mileage of telephone and telegraph circuits has been increased as follows:

Telegraph Circuits.....	471.34 miles
Telephone Train Dispatching.....	901.53 miles
Local Telephone.....	62.13 miles
<b>Total .....</b>	<b>1,435.00 miles</b>

New stations were constructed of Brick, 16; Frame, 14; and others remodeled or extended at 16 points.

New water stations were established at Carona, Mont Ida, Lane and Greenleaf, Kans.; Nevada, Mo.; Dupo, Ill.; and Gurdon, Ark. A new 250 ton mechanical coaling station was completed at Bald Knob, Ark.

A substantial two-story hotel was erected at Bush, Ill., because of the absence of adequate accommodations for employes in the Coal District, and is being successfully operated under an arrangement with the Railroad Young Men's Christian Association.

Total expenditures for Additions and Betterments for the year aggregated \$4,213,387.03 and are listed under "Roads and Equipment" pages 28 and 29.

OPERATIONS.

The revenues from freight, from passenger and all other operating sources each exceeded any previous record in the history of the property, the total operating revenues being \$62,155,506.14, representing an increase of 14.04 per cent over the previous year and equaling \$8,565.00 per mile of road operated (average).

The revenue from freight traffic increased \$6,233,913.52, or 15.78 per cent, and by reason of the longer average haul per ton, the accumulated ton mileage increased 18.23 per cent. The average haul this year was 243.17 miles, an increase of 5.11 miles.

The average revenue per ton per mile was but 8.07 mills, representing a decline of 2.06 per cent.

The tabulated statement on page 50 records the number of tons of each commodity carried, each group showing substantial increases. The groups contributing the greatest tonnage increases being products of mines, products of agriculture and products of forests.

The revenue from transportation of passengers was \$11,627,480.60, an increase of 9.05 per cent. The number of passengers carried one mile increased 8.42 per cent, while the average revenue per passenger, and the average revenue per passenger per mile (2.32 cents), remained substantially the same.

The operating expenses are given in detail and with comparisons on pages 42 and 43.

Federal action, in conjunction with local efforts, has not been sufficient to afford assurance against damage by high water in the lower Mississippi Valley. The properties suffered a repetition of the floods of the previous year, although to much less extent on portions of the lines, principally in Arkansas and Louisiana. This contributed to the increase of 6.91 per cent in the expenditures under Maintenance of Way and Structures, although primarily the excess charges went to the further upkeep and improvements of the physical property; all items of work in connection therewith having gratifyingly progressed. The total charges per mile of road aggregated more than \$1,276.00.

The charges to repairs and renewals of locomotives, passenger and freight train cars, were greatly increased, all classes of equipment requiring very heavy repairs or reconstruction, a large proportion of the excess over the previous year being incident to the increased volume of traffic.

When applied to the equipment owned as at the beginning of the year, the expenditures equalled per locomotive, \$3,436.93, per passenger train car, \$1,241.24 and per freight car, \$90.63. The result of these expenditures has been to decidedly raise the average condition throughout.

The two accounts of Maintenance of Way and Structures and Maintenance of Equipment, combined represent an outgo for upkeep of more

than \$19,000,000 and equal nearly 31 per cent of the total operating revenue.

Traffic expenses increased 4.94 per cent.

Transportation expenses exhibit an increase of 5.92 per cent, which affords gratification compared with the preceding year; the revenue ton mileage increased more than eighteen per cent, and passenger train mileage nearly six per cent, carrying an increase of over eight per cent in the number of passengers carried one mile. The revenue freight per car averaged 18.06 tons an increase of 6.86 per cent, and the average revenue tons per freight train mile were 373.29, an increase of 12.13 per cent.

General Expenses declined 2.75 per cent. There were established 448 new industries adjacent to or on the right of way, and new sidings to meet industrial requirements were constructed to the number of 124.

The operations of the Land Department are recorded on page 55. The Hospital Fund of the employes of the system, heretofore managed by the officers of the Company, was on November 1st, 1912, turned over to a Board of Hospital Service Managers, representing the employes, together with all funds and property then in possession of the Company.

Since the close of the fiscal year the item of Notes Payable of \$425,000 shown on the Missouri Pacific balance sheet page 19, has been reduced by the payment of \$250,000. The remaining \$175,000 represents a note given to Board of Hospital Service Managers, covering a credit to the Hospital Fund on the books of the Company, November 1st, 1912.

Similarly, the indebtedness of the St. Louis, Iron Mountain & Southern Ry. Co. to The Missouri Pacific Ry. Co. shown under Working Assets on page 18 and under Working Liabilities on page 25, has been reduced by the payment of \$1,550,000 on the sale of First and Refunding Mortgage bonds of the Iron Mountain Company held in its treasury.

With the exception of current obligations incidental to operation, the System is carrying no floating debt.

The anticipations of a year ago with respect to the operations of the property, have been quite fully realized. The transition from a deficit last year of approximately two millions of dollars to a "Net Income" credit of \$1,562,734, is but a corollary to the persistent and economic application of energy directed toward the further development of that recognized unit—the welfare of the public and the integrity of the carrier. As the curtailment, so also does the continuation, of this development largely rest with the peoples served by the Missouri Pacific System.

Ordinarily, the expression "density of traffic"—meaning in this instance the average number of revenue tons transported one mile per mile of operated railroad—conveys little, but to state that this measure of quantity increased 17.8 per cent over that obtaining last year, and 28½ per cent compared with two years ago, can not fail to impress both users of the road and the public in general, not only with the tremendous increased wear and tear which must be currently restored, but also and more particularly with the absolute necessity of making the way clearer for securing adequate funds, properly protected as an investment, so that the patent facility and service requirements of the growing communities may be competently met. Action—and action there must be—looking to the accomplishment of that end, constitutes good citizenship, and carries a Nation-wide influence in the common cause of our Country, and is an obligation from which no geographic section can exempt itself.

Wholly apart from and in addition to enormous payments for the System dispensed this last year in wages alone a sum of \$29,000,000.00. It is obvious that the beneficiaries of such should be ardent progressors and defenders in the solution of complex factors which go to make for our mutual and inseparable well-being.

By order of the Board of Directors.

B.

THE MISSOURI PACIFIC RAILWAY COMPANY  
PROFIT AND LOSS.  
JUNE 30, 1913.

Credit Balance, June 30th, 1912.....		85
Credit Balance Transferred from Income Account .....	\$369,697.32	
Credit on Road and Equipment Sold....	120.00	
Delayed Income Credits .....	11,290.67	
Miscellaneous Credits .....	18,768.05	\$399,885.04
<b>Less:</b>		
Debt Discount Extinguished through Surplus .....	\$2,128.80	
Loss on Retired Road and Equipment .....	178,175.06	
Delayed Income Debits.....	14,391.29	
Miscellaneous Debits .....	101,690.76	303,490.13
<b>Credit Balance, June 30th, 1913.....</b>		<b>\$97,988.98</b>

ST. LOUIS, IRON MOUNTAIN & SOUTHERN RAILWAY COMPANY.  
PROFIT AND LOSS.  
JUNE 30, 1913.

Debit Balance, June 30th, 1912.....		41,908.16
Credit Balance Transferred from Income Account .....	\$1,193,036.56	
Delayed Income Credit.....	334.72	
Miscellaneous Credits .....	80,261.12	\$1,274,630.40
<b>Less:</b>		
Debt Discount Extinguished through Surplus .....	\$287,170.00	
Loss on Retired Road and Equipment .....	193,915.68	
Delayed Income Debits.....	34,443.03	
Miscellaneous Debits .....	10,904.40	526,433.11
<b>Credit Balance, June 30th, 1913.....</b>		<b>\$748,200.29</b>

# Railway Age Gazette

PUBLISHED EVERY FRIDAY AND DAILY EIGHT TIMES IN JUNE, BY THE  
SIMMONS-BOARDMAN PUBLISHING COMPANY,  
WOOLWORTH BUILDING, NEW YORK.

CHICAGO: Transportation Bldg. CLEVELAND: Citizens' Bldg.  
LONDON: Queen Anne's Chambers, Westminster.

E. A. SIMMONS, *President.*  
L. B. SHERMAN, *Vice-President.* HENRY LEE, *Sec'y & Treas.*  
The address of the company is the address of the officers.

### EDITORS.

SAMUEL O. DUNN, *Editor.*

ROY V. WRIGHT, *Managing Editor.* E. S. FAUST  
W. E. HOOPER H. H. SIMMONS F. W. KRAEGER  
B. B. ADAMS E. A. AVERILL A. D. CLOUD  
E. T. HOWSON R. E. THAYER GEORGE L. FOWLER  
A. C. LOUDON

Subscriptions, including 52 regular weekly issues and special daily editions published from time to time in New York, or in places other than New York, payable in advance and postage free:

United States and Mexico.....	\$5.00
Canada .....	6.00
Foreign Countries (excepting daily editions).....	8.00
Single Copies .....	15 cents each

Engineering and Maintenance of Way Edition and four Maintenance of Way Convention Daily issues, North America, \$1.00; foreign, \$2.00.

Entered at the Post Office at New York, N. Y., as mail matter of the second class.

WE GUARANTEE, that of this issue 10,850 copies were printed; that of those 10,850 copies, 8,551 were mailed to regular paid subscribers and 2,299 were provided for counter and news companies' sales; that the total copies printed this year to date were 271,359—an average of 8,648 copies a week.

VOLUME 55. OCTOBER 24, 1913. NUMBER 17.

## CONTENTS

<b>EDITORIAL:</b>	
Editorial Notes .....	739
The Necessity for Bumping Posts .....	741
Automobile Fatalities and Railway Fatalities.....	741
Switch Indicators .....	742
New Books .....	742
<b>LETTERS TO THE EDITOR:</b>	
A Locomotive Engineer's Views; by F. E. Patton.....	743
The Origin of the "Safety First" Movement; by F. L. Morse.....	743
An Old Superintendent's Experiences.....	743
An Engineer on the Commission? by E. C. Hurd.....	744
<b>MISCELLANEOUS:</b>	
Proposed Development of Chicago Railway Facilities.....	745
*Hospital Car for the Rock Island.....	748
A Remarkable Safety Record on the Frisco.....	749
An Analysis of Train-Crew Legislation.....	750
Railway Electrical Engineers' Association.....	756
*Jones' Mail Catcher .....	758
Accident Bulletin No. 47.....	759
Railway Signal Association .....	760
The Abatement of Locomotive Smoke; by D. F. Crawford.....	762
Training the Railway Employee; by A. Kipp.....	765
The Railway Situation and Its Causes; by Blewett Lee.....	767
An Early Locomotive Boiler Explosion.....	768
Foreign Railway Notes .....	744, 756, 757, 758, 759, 766, 768

### MAINTENANCE OF WAY SECTION.

<b>EDITORIAL:</b>	
Editorial Notes .....	769
The Railway Track Labor Problem.....	769
New Books .....	770
<b>LETTERS TO THE EDITOR:</b>	
One Engineer's View.....	770
Contracting of Maintenance Work; by A. E. Hansen.....	770
<b>MISCELLANEOUS:</b>	
Suggested Means for Holding Laborers.....	771
Master Painters' Association.....	774
*A New 90-lb. Rail Section.....	774
A Correction .....	774
*Boston & Maine Yard at Mechanicville.....	775
Abstract of Engineering Articles Since September 19.....	779
Pennsylvania Track Maintenance Prizes.....	780
Effect of Treated Ties on Track Circuits.....	780
*A Gasolene Rock Drill.....	780
*An Angle Iron Clip in Place of Drift Bolts to Connect Bridge Stringers to the Cap.....	781
*The Triplelock Switch Machine.....	781
*Moving a Steam Shovel with Traction Engines.....	782
*Triangular Ties on the Great Northern.....	782
*Shifting a Long Section of Track.....	782
*A Concrete Water Trough.....	783
*Bridg and Building Association Meeting.....	784
<b>GENERAL NEWS SECTION</b>	
	794

\*Illustrated.

IN our issue of August 15 we published a description of the scrap reclaiming yard of the Santa Fe at Corwith, Ill. Perhaps many who read the article, and who believe in the possibilities and value of such a department in a railway organization, have wondered how their managements could be persuaded to make the appropriations necessary for installing similar plants. The figures given in the article showed the great savings that have been made by the Santa Fe with its scrap reclaiming plant; and perhaps those figures may be of assistance to others who may seek to secure the establishment of similar plants. There is no enterprising railway management that would be unwilling to take such action if it were convinced that a material saving could be made; and it is up to the mechanical, or stores department, as the case may be, to show how much saving could be made. It may not be enough, however, to point out what some other road is doing; the conditions may be entirely different. It is necessary, in order to make sure that such a plant will be a success, to study thoroughly the conditions of the individual road, ascertaining just how extensive the reclaiming work should be, and just where the reclaiming plant may be most advantageously located. In order to interest and convince the higher officers, those favoring the establishment of reclaiming plants should be thoroughly familiar with all phases of their subject, should have the courage of their convictions, and should be ready to present all pertinent facts when called for. This is especially true at the present time when the many railways that have not all the money that they need are carefully examining all requests for appropriations and granting only those that have been proved to be most meritorious. Practically every road that has installed any kind of a reclaiming plant has found it profitable. The operations of such a plant must be carefully watched, however, for some material that is reclaimed at a profit on one road may not show a profit on another. The necessity of a business head is paramount if the plant is to be run on a profitable basis. A good accounting system is necessary to show whether the various kinds of material actually are being reclaimed at a profit. The department should be run on strictly business principles, for it is in fact a manufacturing plant being operated rather to save or make money for the company than to supply material for its needs.

THE advocates of government ownership angrily denounce the railways of this country for seeking advances in rates. They imply, or even assert, that if the roads were owned by the government they would be making reductions instead of seeking advances. The writings of the advocates of state ownership conflict with developments that have been, and are, occurring on state railways throughout the world. On state as well as on private lines the tendency of wages and other expenses is upward, and in consequence they, like private railways, are seeking higher rates. W. M. Acworth has mentioned it as a characteristic of government railways that they can advance their rates with less trouble than private railways, and the evidence supports him. In the annual report of the New South Wales government railways for the year ended June 30, 1913, which is just at hand, the Chief Commissioner points out that during the year there were heavy increases in expenses, chiefly due to advances in wages. In consequence the ratio of operating expenses to gross earnings increased from 64 per cent. to almost 69 per cent., and the surplus, after paying working expenses and interest, was reduced from £415,500 to £187,000. The Chief Commissioner anticipates that there will be further increases in expenses in the fiscal year 1914, and "In consequence, from the commencement of the new financial year," he says, "season ticket fares and certain goods rates have been increased so as to provide additional revenue to meet the anticipated increase in working expenses." Similar increases in rates due to similar causes have been occurring on

the state railways of Continental Europe for several years. In October, 1909, Switzerland raised its season ticket rates 18 per cent. On January 1 and May 15 the rates of the Austrian state railways for certain bulky goods, such as cement, sugar, spirits, coal and wood for export, were increased, and these raises followed advances in local rates which had been made in 1911. The Hungarian state railways advanced their fast goods rates about 7 per cent., and their slow goods rates about 5 per cent., on April 1, 1912, and their zone passenger fares for the 62-mile zone have been increased 13 to 14 per cent., and for the 124-mile zone by about 15 per cent. The Italian state railways have made increases of 6 to 9 per cent. in their passenger fares, and of 2½ cents per ton in the fees for despatching freight traffic. On December 1, 1911, the Danish state railways made general advances in their passenger rates, and on January 1, 1912, advances of about 9 per cent. in their goods and live stock rates. The German state railways have within recent years made some advances in their round trip passenger fares, and have abolished the former free baggage allowance of 56 lbs. The government-owned Intercolonial of Canada also recently has announced some substantial advances in rates. Nowhere in the world have the increases in railway wages and in the prices of railway materials been greater in proportion than in the United States, and yet, rates in this country have remained stationary or tended downward. The average per passenger mile here in 1902 was 1.986 cents, and in 1912, 1.985 cents. The average per ton per mile in 1902 was 7.57 mills, and in 1912, 7.43 mills—the lowest figure ever reached except in 1859 and 1900.

**W**. M. ACWORTH, the English railway economist, once expressed astonishment at how much the professors of economics in American universities knew about the theory of railroad transportation and how little they knew about its practice, and at how much the officers of our railways knew about the practice, and how little they knew about the theory. This remark is recalled by the appointment of Professor W. J. Cunningham of Harvard University, to an important official position on the New York, New Haven & Hartford. Mr. Cunningham is an unusual combination of the practical and theoretical. While he was engaged in railway work as a clerk and statistician he studied the theory of transportation to such good purpose that he was given a lectureship, and subsequently an assistant professorship, in Harvard. After he began teaching he kept in touch with practical railroad work by actually continuing to do such work as well as by traveling extensively and studying railways all over this country and in Europe, which, of course, improved his teaching. It is his purpose, while serving as president's assistant on the New Haven, to continue to do university work. The opportunity to do railway work and professorial work at the same time is not given to many. But the opportunity to combine a knowledge of theory with a knowledge of practice is given to many in railway service, and it is unfortunate that it is seldom availed of. The fact is, that the railway man, in whatever department he may be, who has formulated for himself a full set of principles regarding the way in which rates should be adjusted, or in which railways should be regulated or should serve the public, and who insists on applying his principles to practical problems as they arise, is likely to be criticized by his associates as a "theorist," and being a "theorist" is assumed to detract rather than add to his value to his road. This point of view is narrow, and is one of the causes of some of the most serious troubles that the railway managements of this country have had. Men cannot act according to sound principles unless they know them, and they cannot effectively defend what has not been done on sound principles. A man who is ignorant of, or disregards, sound principles may "put things over" more successfully because of this; but the patrons of his railway, its employees and the public will in due course discover his character and his methods, when there will be a day of reckoning. The universities of this country need more pro-

fessors who understand the practice of transportation as well as its theory. And the railroads need more men who understand the theory and principles of railway operation as well as its practice.

**I**N a discussion of street railway accidents at a meeting of the American Electric Railway Claims Association at Atlantic City last week, one of the speakers mentioned the excellent results which had followed the introduction of the practice on his road of not only giving a complete statement of all serious accidents to the press, but also of fully explaining the reasons of delays to the movement of cars which might cause more or less inconvenience to the public. It is the delays to steam trains—the insignificant ones as well as those of a more serious character—and the way in which many of the roads refuse to take patrons into their confidence concerning them, that often does much to place the roads in a most unfavorable light in the eyes of the public. While, except in the most aggravated cases, it might not do much good to attempt to explain the delays through the press, for this information would not have sufficient news value to warrant publication, still many of the steam roads could help the situation greatly by giving more attention to this matter. The same speaker commented on the fact that although the press in his district was antagonistic to the street railway, yet almost invariably such statements as the railway gave to the press concerning accidents and delays were printed in full. Another way in which conditions might be greatly improved would be to give more attention to the bulletin boards at stations. It is not unusual, even at large and important terminals, to have trains marked "on time" which may not arrive within 15 minutes, a half an hour, or even more, of the schedule time; sometimes, and in spite of the fact that the attendants are not overworked and have plenty of time, a train will come in quite late and still be marked "on time" on the bulletin board when it does arrive. One need only to watch the faces of those who are impatiently awaiting the arrival of the train and to overhear some of their expressions, to realize that the reputation of the road is suffering more harm than could be offset by thousands of dollars' worth of advertising and publicity. This is all the more aggravating when the uninformed employees apparently make no effort to find out the true situation, pay no attention to making corrections to the bulletin board, and yet have plenty of time for story telling and joking among themselves. The standing of the road would suffer far less if a greater effort were made to keep the information on the bulletin boards as correct as possible, and if the employees in the event of delays would make an extra effort to deal courteously with its patrons. Too much cannot be done to train those employees who come in direct contact with the public—and they are the ones by which the road is judged—to get a larger view of their responsibilities.

**A** RAILWAY mechanical department officer recently remarked that a railway shop was run with the idea of getting out work in the quickest possible time, expense being a secondary consideration, whereas the contract shop has to make a profit in order to exist. There are not many contract shops, but some roads find it cheaper to have the repairing of equipment done in them rather than in their own shops. If the same care and supervision were given the railway shop, could it not do the work as cheaply as the contract shop? The reason why the contract shop is operated more economically is that its head is a business man, as well as an expert in the methods of repairing equipment, and he aims to have his work done as quickly, as cheaply, and as well as possible, for he, like the railway shop superintendent, is subject to the early delivery demands of the transportation department. That there is considerable waste of money in the ordinary railway shop there is no question, and more attention and study should be given to shop economies. The men in charge are usually taken from the ranks; their chief

characteristics usually are those of successful handlers of men; and it is seldom that they possess the commercial experience and qualities of the successful business man. Yet such experience and qualities are necessary to the management of a shop to make it really pay. Many roads have special men on the staff of the shop superintendent, who make a study of shop conditions with a view to getting the various jobs performed in a shorter time and at less expense; who, in other words, act as business men for their chiefs. Such a man, if fitted for his work, is an important factor in reducing shop costs, and will save his salary many times over. But he should be carefully selected for his position. He should be broad minded, as well as intimately familiar with shop work. He should be practical, as well as theoretical, so that he may apply his ideas to the best possible advantage. His studies should not be restricted. He should have free rein to study the arrangement of tools, the routing of material, the distribution of small tools, etc. On roads having numerous small shops, he, or his assistants, should travel from shop to shop, aiming at each point to put the shop on a commercial basis. Such a man is, to be sure, a high priced man, but if he has the qualifications for his work he will be well worth his hire. Unfortunately, there are few roads that are willing to pay the price necessary to get the right sort of man and to enable him to do the most effective practicable work.

**THE NECESSITY FOR BUMPING POSTS.**

**A** BUMPING POST is absolutely necessary at stub end passenger terminals, at the ends of tracks abutting buildings, on docks and coal chutes, and at other places where the damage resulting from a car or engine going over the end of the track may be great. Only recently an engine went over the end of the track, through the fence and part way across the concourse at the North station, Boston, and only a few days later there was a similar occurrence at Jersey City. To remove this danger at passenger terminals, without at the same time causing too great a shock to trains, a new hydraulic bumper has recently been installed and tested at the Grand Central Terminal, New York.

However, the most common need for bumping posts is on team and freight house tracks, industry tracks, etc., where the damage resulting from a car going over the end of the track is comparatively small. No matter how long a track is, a car is likely to be pushed over the end and "home-steaded" sooner or later. In a busy yard with several crews at work, it is often difficult to place the responsibility for such carelessness. For this reason bumping posts have frequently been installed where they would be unnecessary, with proper handling of cars by the switchmen. When once bumping posts are installed men tend to become more careless, with a resulting increase in damage to track and equipment. In many cases where bumping posts are in service they could be removed to advantage, if there were enforced the disciplinary measures necessary to keep cars from being shoved off the end of the track. Several roads are installing bumping posts less generally than formerly, and in some instances are even removing them, relying upon more careful instruction and discipline to remove the need for them.

In designing bumping posts, the first point to be determined is to what extent the movement of a car is to be arrested; in other words, whether, when the post comes into actual services it is the car or the post that is to be damaged. The most generally adopted posts are designed to arrest any ordinary movement of a car, but to be broken or overturned rather than cause a car to be seriously damaged. Track men who complain that such posts require frequent attention lose sight of the true nature in designing them. It is entirely possible to design bumping posts which will withstand any shock that can be given by an ordinary car, and such are now being built, especially of concrete, on a number of roads. But here a protest immediately arises from the car depart-

ment that the equipment is being damaged. An advantage of the heavy post is that rough switching is brought more forcibly to the attention of the operating department when cars are being damaged than when the posts are being broken or overturned, and as a result corrective measures are more promptly applied. But this merely goes to prove that the need for bumping posts in many locations can be eliminated by proper disciplinary measures.

**AUTOMOBILE FATALITIES AND RAILWAY FATALITIES.**

**F**REDERIC REX, municipal reference librarian of Chicago, has compiled statistics which show that in 1912 the number of persons killed by automobiles in 22 American cities having 100,000 or more population was 691. His compilation demonstrates that there has been an appalling increase in automobile fatalities during recent years, the number occurring in the same cities in 1907 being only 176. Mr. Rex's figures are as follows:

City—	Deaths		Per Cent. Increase.
	1912.	1907.	
New York City.....	226	55	310.0
Chicago.....	98	15	553.3
Philadelphia.....	54	11	390.9
Boston.....	34	9	277.7
Cleveland.....	32	5	540.0
Baltimore.....	9	3	200.0
Pittsburgh.....	28	10	180.0
Detroit.....	34	8	325.0
Buffalo.....	21	7	200.0
San Francisco.....	19	15	93.3
Milwaukee.....	7	3	133.3
Cincinnati.....	18	5	260.0
Newark.....	7	5	40.0
Los Angeles.....	29	5	480.0
Kansas City.....	12	2	500.0
Seattle.....	14	5	180.0
Indianapolis.....	11	2	450.0
Providence.....	10	2	400.0
St. Paul.....	5	1	400.0
Denver.....	11	7	57.1
Toledo.....	7	0	57.1
Memphis.....	5	1	400.0
Total.....	691	176	340

As we have said heretofore, while railway accidents in this country are often discussed as if they were a peculiar disease, the fact is that our record for railway accidents is no worse than our record for other kinds of accidents. These statistics regarding automobile fatalities illustrate and emphasize the point. As they relate to fatalities in only 22 cities, they represent but a part of the total occurring in the entire country. Nevertheless, some very striking comparisons can be made between them and the statistics regarding certain classes of fatalities on railways.

The number of passengers killed in all ways on all of the railways of the United States in the year ended June 30, 1912, was 270. In other words, the number of persons killed by automobiles in only 22 cities was 64 per cent. greater than the total number of railway passengers killed. It was likewise five times as great as the number of passengers killed in train accidents alone, which was 139; and it was greater than the number of passengers, railway employees and all other persons, excepting trespassers, killed in all railway collisions and derailments, the total killed in collisions and derailments, excepting trespassers, being 685. The largest number of passengers ever killed in all ways in one year on the railways of the United States was 647, and yet this worst of all records, which was made in 1907, was 44 less than the number killed in automobile accidents in 1912 in the 22 cities.

The accident record of the railways is being used by some writers as an argument for their acquisition by the public. It is assumed that if the public owned them it would operate them safely. The public already owns the streets and highways, and these figures regarding automobile accidents indicate how safe it makes them. It so far fails to make them safe that the number of persons killed by automobiles in only 22 cities was 64 per cent. greater than the number of passengers killed by the railways in hauling over 994,000,000 persons an average of over 33 miles each, or a total of 33,000,000,000 miles, on more than 240,000 miles of line.



Automobile accidents are due to the careless and reckless conduct of those who use automobiles and of pedestrians, and to the failure of the public to pass and enforce suitable laws to stop this careless and reckless conduct. Those who assume that if the public owned and managed the railways it would operate them safely show a remarkable disregard for the way in which the public and the governments in this country perform duties already undertaken by them affecting the health and safety of the people.

#### SWITCH INDICATORS.

THE Railway Signal Association, at its annual meeting, held last week, at Nashville, and reported in this issue, devoted its attention largely to matters of detail; questions which, though of the highest importance, are almost necessarily neglected by the operating officer because of their multiplicity and their delicacy. He cannot spare the time. But there was one question in which every operating officer will be interested; that of the flagging rule vs. automatic signals. Some of the difficulties connected with the enforcement of the flagging rule on roads where the flagman knows that a block signal system has been provided for the prevention of collisions, were noticed in an article printed in our last issue. In a different shape the same problem came up at Nashville. It was in a discussion on the question of the use or non-use of electric indicators at outlying switches on lines equipped with automatic block signals. As is usual in matters concerning which the results of experience are not well known, there was a large proportion of opinion and a small proportion of fact, in the statements made by the several speakers. The main issue in this case is the same as in most other discussions involving flagging; but the question is somewhat simpler; for those who believe that the use of indicators is not advisable advocate the complete abandonment of the apparatus. In considering flagging in connection with straight block signaling it is out of the question to take any such radical position.

The indicator question, in its primary stage, is quite clear. The indicator, when in its "clear" position, tells the conductor of a train which is in the siding that that block section is clear, from end to end; that, therefore, he may safely move his train from the siding to the main track. But the rules require him to protect himself by flag, just the same as though he had not received information as to whether or not a train might be approaching; and so the opponents of indicators declare that the money spent on them might as well be saved, for they do not expedite traffic, and, if the flagging is effective, they serve no purpose as a safeguard.

We may pass over the familiar arguments which are common to this and other flagging problems. Whether signals can ever be considered so perfect as to free the superintendent from all anxiety as to the possibility of disaster because of their failure, and whether trainmen can ever be trained to flag as faithfully as the rules require, are questions which will never be settled until more railroad officers become possessed with an earnest desire to see them settled. But the Nashville discussion developed two points which deserve the attention of all superintendents whose lines are worked under the automatic block signal system. The representative of the Michigan Central, on which road these indicators are used as extensively as anywhere in the country, gave, as his first reason for using them, the fact that without them the automatic block signal system is markedly deficient. It is not a complete system. With an incomplete system the investment is not earning the full interest that it should. An all-clear indication at a block signal should mean to the engineman "all-clear" throughout the length of that block. If there is the condition that the flagman of a freight train may be encountered at any side track or crossover the signal is not giving the engineman the assurance that he ought to receive. The indicator is to be looked upon as an essential, even a vital element in the complete system.

The other point which was brought out, and which was based

on the experience of the Michigan Central, was that with the indicators better results are secured than without them. This was stated with a positiveness which evidently was based on carefully considered evidence. The officers of the road prefer to depend on a reliable machine rather than on a man. A consideration of the question whether the Michigan Central trainmen do or do not make proper use of the indicators in all cases, or whether they would flag more carefully if they had no indicators, might lead to all sorts of doubts and insoluble difficulties; but the net result stands, without regard to whether these questions are answered or not. The usual way of looking at matters of this kind is to demand that the machine accomplish complete perfection. If it will make the man-protection absolutely and forever unnecessary we will consider its adoption. As against this idealistic proposition the Michigan Central people declare that they already prefer the machine, without waiting for a decision on the question of millennial perfection.

The discussion at Nashville brought out another significant thing. In the midst of the claims, pro and con, as to the efficiency of men, whether in protection of movements from sidings by flag or in faithful compliance with the rule requiring examination of the indicator previous to each movement, one member declared that the whole question hinged on one thing: "Educate your trainmen!" This point was greeted with loud applause. Signal engineers have at times been accused of taking only a languid or an unintelligent interest in operating questions; they are too prone to try to give the superintendent whatever he demands, in the way of appliances, however, unreasonable may be his views, when the true course, quite likely, would be to call on him to conform his practice to the signal engineer's standards, or views. That spontaneous applause gave unmistakable evidence that signal engineers have very definite ideas as to what the superintendent ought to do, even though they do generally seem rather timid about telling him their thoughts.

#### NEW BOOKS.

*Field Engineer's Handbook.* By G. Carveth Wells, Federated Malay States Government Railways, and Arundel S. Clay. Size 4 in. x 6½ in., 228 pages, 79 illustrations, bound in leather. Published by Longmans, Green & Co., New York. Price \$2.10.

Intended primarily for use in England and in the British colonies, this book differs considerably from the numerous standard field books commonly used in this country, especially in the greater attention given to astronomy and the determination of time and azimuth. Being intended primarily as a surveying rather than a railway handbook, considerable attention is given to the adjustment and care of instruments, although attention is also given to the problems of railway location, transition curves and typical construction work. Four tables of curve properties and one giving the accelerations of the mean sun are given in the back of the book.

*Locomotive Boiler Construction.* By Frank A. Kleinhaus. Bound in cloth. 478 pages. 5½ in. x 8 in. 350 illustrations and five folding plates. Published by the Norman W. Henley Publishing Company, 132 Nassau street, New York.

This is the second edition of this book and it has been considerably revised and enlarged. It takes up the locomotive boiler in the order in which its various parts go through the shop. Each step is considered thoroughly and details of construction are given. Information is included on the life of riveters, punches and dies; work done per day, allowance for bending and flanging sheets, etc. The Federal Government locomotive boiler inspection laws and examination questions with their answers are included. Among the subjects considered are laying out work, flanging, punching, shearing and plate planning, bending, machining parts, boiler details, assembling and calking, finishing parts, boiler shop machinery, tables, etc. Plates are given showing the types of modern locomotive boilers.

## Letters to the Editor.

### A LOCOMOTIVE ENGINEER'S VIEWS.

COLUMBUS, Miss., September 26, 1913.

TO THE EDITOR OF THE RAILWAY AGE GAZETTE:

The railroads have been scored and criticized recently by the Interstate Commerce Commission for using other than steel equipment for passenger service. It is true that steel is superior to cars of wooden structure, and all roads are putting them into service as fast as they possibly can. But, when steel equipment is used it is necessary to increase the motive power in order to make the schedule time, on account of the additional weight, and maintain the same speed. In my opinion the heavy equipment has increased so rapidly that it is now about ten years in advance of the track. Track is the foundation, and it should be the first thing to consider, before increasing the weight of equipment.

The rate the American people have been going for the past ten years is "about ten seconds ahead of a conniption fit," and I believe that if the speed of all fast trains were to be reduced to between fifty-five and sixty miles an hour (on roads where modern equipment and signals are used) accidents would be reduced to a minimum and the public would soon learn to be satisfied.

The first thing the railroads should do is to stop butting and rear collisions. If necessary, reduce the speed to do this. Then the equipment might be either wood or steel, so long as the braking power was up to the highest standard of efficiency.

Safety first: Steel equipment next.

F. E. PATTON.

### THE ORIGIN OF THE "SAFETY FIRST" MOVEMENT.

NEW YORK, September 30, 1913.

TO THE EDITOR OF THE RAILWAY AGE GAZETTE:

In an editorial headed "Wanted: A Sense of Responsibility and Duty" in the *Railway Age Gazette* of September 19, 1913, it is stated that the "Safety First" movement was started by R. C. Richards, general claim agent of the Chicago & North Western.

The "prevention of accidents" or "safety first" movement was fully and formally inaugurated by the United States Steel Corporation in May, 1906, nearly five years before it was introduced on the North Western by Mr. Richards.

The corporation maintains a very efficient "Bureau of Safety, Relief, Sanitation and Welfare," of which C. L. Close is the manager. Undoubtedly, the "Safety First" idea was also original with Mr. Richards, but he always gives the Steel Corporation credit for being the pioneer in this great field. In this connection, I quote as follows from his address before the New York Railroad Club on February 21, 1913:

"The chairman was kind enough to introduce me here as the 'Father' of the safety movement. That is a mistake. The safety movement originated with the United States Steel Corporation about four years ago. We began it on the North Western a little over two years ago. We did not know the Steel Corporation had started it, but afterwards found it out. We are under great indebtedness to that company. . . . And I am sure that if you gentlemen who are interested in the safety movement desire any assistance, there is no place in the world you can go where it will be more cheerfully accorded you than through the officers of the United States Steel Corporation."

F. L. MORSE.

[The meaning it was intended to convey by the statement in the *Railway Age Gazette* to which Mr. Morse refers was merely that R. C. Richards was the father of the "safety first" movement on the railways. We were aware that a similar movement had been previously started by the United States Steel Cor-

poration; and it was far from our purpose to detract from the credit for its pioneer work along safety lines which the Steel Corporation richly merits.—Editor.]

### AN OLD SUPERINTENDENT'S EXPERIENCES.

CINCINNATI, Ohio, October 1, 1913.

TO THE EDITOR OF THE RAILWAY AGE GAZETTE:

The recent troubles of the New York, New Haven & Hartford have brought out an astonishing variety of remedies. Mr. Baer of the Reading is of the opinion that the remedy can be found in a rigid and unswerving discipline. Mr. Bardo, general manager of the New Haven, insists that the working agreements with the enginemen are the fundamental cause; while the enginemen are equally certain that Mr. Bardo is mistaken. The Connecticut commissioners seem to think that the trouble was cumulative; had the proper thing been done at the proper time the collision would have been averted. Interstate Commerce Commissioner McChord takes a somewhat different view; and includes as the guilty ones the president, the board of directors and, for full measure, the firm of J. P. Morgan & Co. Senator Cummins also thinks he has found the potent elixir; but it remains for Dr. Parkhurst to resurrect the old and moth-eaten suggestion that a director should be compelled to ride on the engines of all fast trains. Even the *Railway Age Gazette*, if I read aright, has several times given its opinion that collisions could be generally checked if the superintendents and train masters had sufficient back-bone to enforce compliance with the rules.

Out of all of these opinions, however, we can get no inkling of the impelling motive that actuates an engineman in running at an unsafe speed in foggy weather. Is not the answer to be found in the insistence upon schedule regardless of the conditions? It is a well-known fact that enginemen do not run by speed, but entirely by their watch and the time table; that is to say, they govern their speed by the time shown in the schedule. No engineman can distinguish between fifty miles an hour and sixty miles an hour. This insistence upon schedule has gone so far that a certain eastern road advertises extensively in the public prints, giving in detail the operation of its fast trains, showing the number of times run, number of times late, etc., as a reason for using its line. But no analysis is given of the performance, and no one knows whether this exhibit has been brought about without infraction of the rules of safety.

In railroad operation today the burden is upon the engineman. The amount paid him is of little consequence if his work is well and faithfully performed; he is cheap at any price; while the reverse is true of the inefficient, the reckless and those men who will never make capable enginemen regardless of their personal worth.

It seems reasonable to assume that a man who has survived the wear and tear as a fireman for a period of five or six years, would make a good engineman after he has passed, no matter how perfunctorily, the necessary examinations. And yet he may be intelligent and have the necessary stamina, but be so deficient as to be unable to concentrate his attention; entirely unfitted to be depended upon to do the right thing at the right time.

Ridicule is a potent weapon, and nowhere is it more used than in railroad life. The fact that No. 1, with John Jones in charge, lost three minutes on the run is a subject of general conversation; and after the chief despatcher gets through with the investigation, Jones makes up his mind that it shall not happen again. He exceeds the schedule some day and up goes a bulletin commending the performance, without investigation as to how the result was accomplished.

Had the ill-fated *Titanic* swerved a little to southward and escaped the iceberg which caused such an appalling disaster, there is no doubt that upon arrival at New York these same passengers who suffered so grievously would have joined in praise of Captain Smith for his excellent management in bring-

ing them safely into port. We find the same spirit on our railways. Leaving aside the oft repeated inference that officers and men are callous as to wrecks, this constant striving after results, regardless of the manner in which these results are obtained, in large measure explains why enginemen, and others, persist in seriously taking these "chances." If all goes well and good the plaudits of the multitude; if disaster, nothing too harsh.

I have before me a working time table of a large road and on the bottom of each page is the following: "Passenger trains must not exceed a speed of sixty miles per hour." Yet I find train No. 11 scheduled at "A" 12:26, "B" 12:29 three minutes-distance 3.3 miles. This in itself is enough to lead an engineman to violate specific instructions if he is to maintain schedule.

In most schemes of discipline cases of infraction of the rules, damage, etc., are settled by a suspension for a certain number of days or by dismissal. It is a serious matter to deprive a man of his means of livelihood, and particularly is it barbarous to discharge a man after many years of service at the mere whim of a superintendent or trainmaster. In view of well known facts of this kind perhaps no complaint can be made if the labor organizations, by their power of bargaining, have succeeded in not only protecting the good man, but also at the same time the lazy and inefficient.

To a layman the working agreements seem very mild, outside of the wage question; but, however innocuous they may appear, they do effectually restrict the judgment of the officers to the first employment. After this formality is gone through with, the little book provides for the rest, as discipline cannot be enforced unless charges are made and substantiated in writing. That is to say, the employee must be insubordinate or do damage of some kind. For this reason discipline has grown less and less, and such discipline as is administered is predicated usually upon the amount of damage done at the time, and not upon the gravity of the rule. That is, if no damage is done a reprimand is usually considered sufficient; if the damage is \$1,000 or so, possibly two weeks' suspension will be the penalty; if \$10,000, thirty days, and so on.

The minor officers, such as trainmasters, road foremen of engines and the like, are usually promoted from the ranks under the beneficent protection of Rule No. 1. They usually start out in their new position in an earnest effort to correct the evils with which they are familiar, but in a few days their ardor suddenly cools and the supervision becomes perfunctory.

This sort of supervision leads to slovenly work, such as I witnessed a few days ago. An engineman on duty with his feet out of the window of the cab! An engineman of a train widely advertised leaves his place on the foot board while running at a speed of from 45 to 50 miles an hour, and with the fireman, steps into the gangway and salutes some one; and he was not yet in his place as the train went out of view. The train register of a large railroad in a public place at a station, accessible to the curious, bearing no date at top of page and in a generally dilapidated condition.

As even proper discipline, which certainly should correct such conduct as the above, seems to have become impotent, we have the "Safety First" movement. This, whatever its merits, certainly is a confession that the present methods are defective; it says that force cannot be used and that perhaps persuasion will work the miracle. It does no good to brand Engineman Miller as a criminal, which he certainly is not. He is only the logical result of the system itself.

To maintain high speed where the traffic is dense, it is essential that the railroad company provide for honest and sufficient supervision and deal fairly with the engineman; an intelligent understanding on the part of the officers as to what is required under any schedule being important; and, in addition, an efficient signal system. That this is correct, is found in the performance on the Pennsylvania and Philadelphia & Reading between Philadelphia and New York, where the traffic is exceedingly dense and frequently operated under a two minute headway.

I want to bear witness to the many good men whom it has been my good fortune to meet in the ranks; men who have faithfully performed their duty without thought of reward; and at the same time I desire to pay my respects to the "irreducible minimum" of shirkers and retarders. The man of this type sticketh closer than a leech, protected by the little book, and he leaves his trail mark upon the reputation of good workmen and officers alike.

"SOUTHERN."

#### AN ENGINEER ON THE COMMISSION?

LINCOLN, October 18, 1913.

TO THE EDITOR OF THE RAILWAY AGE GAZETTE:

It has been announced in the press recently that Hon. Charles A. Prouty, now a member of the Interstate Commerce Commission, is to retire at an early time to assume the duties appointive in charge of the national valuation work now inaugurated. Should this report be authentic, a vacancy on the commission itself will occur. No doubt one of the greatest problems before any body, or likely to be soon, is that of finding the value of our railroad, telegraph and telephone properties. True engineers and economists are being employed and will be retained to carry out the major portion of the work involved.

This, however, cannot be said to deprive of farce the suggestion of the advisability of filling the approaching vacancy by the appointment of an experienced, capable engineer as a member of the commission. For numerous good reasons this suggestion seems pertinent, and it is felt it should be brought to the attention of those having authority to name the new man. In other walks of life we select those professionally qualified for the boards which are determining questions that are vital to our welfare and guidance, and why should not the same principle be applied in this matter? It is believed that this suggestion is worthy of consideration, and should receive the active support of those in sympathy with it.

E. C. HURD,

Engineer, Nebraska State Railway Commission.

GERMAN RAILWAY OPERATIONS IN CHINA.—The Shantung Railway connects the German colony at Tsingtau with Tsinan, capital of Shantung province, a distance of 256 miles. Tsinan is a city of about 250,000 inhabitants, with future prospects of an increasingly larger population. Shantung province is supposed to be the most densely populated of the provinces of China, having about 600 persons to the square mile. The Shantung Railway is a German owned and operated line. The completion during the year 1912 of the Tientsin-Pukow Railway, which passes through Tsinan, resulted in connecting Tientsin with Tsingtau over the Shantung Railway, thus giving Tientsin another sea outlet, or rather rail connections with a deep water harbor. During the year 1912 the Shantung Railway's gross income was \$2,225,000, as compared with \$1,750,000 in 1911, while expenses were \$590,000 for 1912 and \$522,000 for 1911. To meet the competition of the Tientsin-Pukow line the Shantung Railway was obliged in December of 1912 to reduce its freight rates by about 40 per cent. During the year 1911, the revenues of the company were greatly reduced on account of the plague and floods in the province, but these losses were recovered in 1912. Receipts for passengers for 1912 aggregated \$490,000, as compared with \$360,000 for 1911. The receipts for freight totaled \$1,700,000 for 1912 and \$1,400,000 for 1911. It is expected that the Shantung Railway will make an even better showing during 1913 than in 1912 on account of the completion in December, 1912, of the Tientsin-Pukow Railway which, while it produced a certain amount of competition, permits the Shantung Railway to tap the whole of the region in proximity to the northern section of the Tientsin-Pukow line. It is reported that the German government is making strenuous efforts to extend the Shantung Railway's concession so as to permit the extension of its line to Shun-teh-fu on the Hankow-Peking Railway, thus tapping a certain densely populated section of central and west China.

# PROPOSED DEVELOPMENT OF CHICAGO RAILWAY FACILITIES

Two New Passenger Terminals Recommended by John F. Wallace; One for the South Side and One for the West Side.

John F. Wallace, president of Westinghouse, Church, Kerr & Company, presented to the Chicago city council committee on railway terminals on Monday, October 20, a report making recommendations as to the future development of the Chicago railway terminals. Mr. Wallace was engaged by the committee to study the terminal situation of the city with particular reference to the plan proposed by the Union Station Company for replacing the old Union station, and to general terminal plans proposed by various interests, which have been described in the *Railway Age Gazette*. Bion J. Arnold, who has been engaged by a citizens' committee to make an independent investigation, reviewing Mr. Wallace's recommendations, will submit his report in a few weeks. An abstract of Mr. Wallace's report follows:

## PASSENGER TERMINALS.

The need for a general change in the facilities now used in the passenger and freight business of most of the railways of Chicago is apparent to the most casual observer. The traffic of the railways is constantly outgrowing their facilities for carrying on the business. But it is not the railways alone that are confronted with a problem of transportation, for likewise the traffic of the city has outgrown the capacity of the streets in the central business district, both as to the use of the sidewalks and of the roadways.

The business district of the city, represented by the area on the south side, north of Twelfth street, substantially one mile square, is not only hemmed in on all sides by the railways, but is penetrated for about one-half of this distance by railway extensions inwardly from the south, so that the area free from railway occupation is limited to the central district, north of Van Buren street, and is in effect about one-quarter of a square mile.

Of the various plans that have been suggested for union station passenger terminals, none would eventually so effectually bar the expansion of the business district of the city southward as the proposal to locate such terminals at Twelfth street, occupying all the space between State street and the river.

The outlet for expansion of the business district southward of Twelfth street should be kept open between Michigan avenue and the river to the utmost extent possible.

Looking now to the west side, we find that from Twelfth street north to Madison street the railways are limited to a narrow strip of land lying between Canal street and the river, with tracks so much below the grade of the city streets as not to interfere with all the east and west streets being carried over the railway property on viaducts the full width of the streets, and of easy grades. It may therefore be proper to leave this railway strip to such intensive development as the railways deem advantageous to make.

From Canal street westward to Western avenue, a distance of  $2\frac{1}{2}$  miles, and from Twelfth street northward to Madison street, a distance of one mile, the west side of the city has an area of  $2\frac{1}{4}$  square miles free from railway tracks, which offers great opportunity for industrial and commercial development.

To the northward the railways are substantially confined to a strip along the river and its north branch, leaving for business development on the north side an area extending from Kinzie street to North avenue,  $1\frac{1}{2}$  miles, and from the river to the lake,  $1\frac{1}{2}$  miles, equaling 2.25 square miles.

As a result of a study of existing conditions, it is self-evident that the principal thoroughfares connecting the central district with the north, south and west sides of the city should remain open and unobstructed, and provision be made for the widening of the more important ones as future necessities may require.

The railway approaches to the city of Chicago are along seven different routes. Of these seven, four are east and south of the river, while three are north and west of the river.

There are at the present time six railway passenger terminals in the city. (Here follows a description of the present terminal facilities.)

Of the five older terminal passenger stations now in use, three, the Union station, the Illinois Central station and the Dearborn station, have served their purpose, and must soon be replaced with more commodious structures. The La Salle street station, by the growth of business, will require enlargement or replacement within the next ten years. The Grand Central station, while admirably arranged, is badly located, with a drawbridge across the Chicago river near its train entrance. It is of small capacity. The interests now owning this station might find it profitable to have the railroads using it secure facilities elsewhere, and dispose of this property for commercial use. The Union Station Company has submitted plans for a greatly enlarged passenger terminal located on Canal street, upon substantially the same site as to train shed and tracks that it now occupies. The Dearborn Station Company has not as yet submitted plans for a new and enlarged passenger terminal, and it is not known what improvements it has in contemplation. The Illinois Central, owning the Central station, has plans in course of preparation for a new and greatly enlarged passenger terminal, located at Twelfth street and the lake front, with a possible capacity, on two levels, for taking care of all the railroads on the south side of the city, now using stations east of the Chicago river.

Measured by the needs of the community alone, at least two general locations for railway passenger terminals are necessary to meet present requirements. One on the south side and the other on the west side, between Van Buren and Madison streets adjacent to Canal street.

It should be remembered, however, that the railroads now occupying other sites have vested rights in the present holdings and cannot be forced, without their consent, to remove or rebuild their existing terminals; and only their inability to take care of their expanding business or an opportunity to increase their revenue or reduce their operating expenses would probably induce them to abandon their present locations. The Lake Shore and Rock Island station needs, however, special consideration, from the standpoint of public convenience, on account of its accessibility to and from the business center, particularly for its suburban business.

The new North Western station, at Canal and Madison streets, having been designed to serve the purposes of one road, another station to provide for the group of roads now established in that locality and using the old Union station becomes a necessity, as much from the standpoint of the public using it and the business interests situated in the heart of the city, as from a railroad point of view.

Upon the south side of the city a location at Twelfth street and Michigan avenue lake front appears to be one that can be suitably provided on property available only for railroad uses, and without blocking business development southward.

Under the agreement between the South Park Commissioners and the Illinois Central Railroad, executed in 1912, the railroad company is granted additional lands on the lake front, which together with previous holdings, gives it a site for its new passenger terminal southward from Twelfth street, 750 ft. in width, with an extension over 600 feet in width nearly to Thirty-first street, a distance of about two miles. Upon this site it is possible to construct a new central station on two levels, providing for 30 stub tracks on each level, a total of 60 tracks, all available for through passenger trains; the suburban trains to be run through the station in a subway on an independent set of tracks.

The widening of Twelfth street westward, with the widening and improvement of Michigan avenue to the north side, will

provide thoroughfares of exceptional character for vehicle traffic from the north, the west and the south sides of the city to a passenger terminal located at Twelfth street and the lake front. The site for the station at the south end of Grant Park affords splendid opportunity for architectural effect, and the broad right-of-way southward for several miles along the shore of the lake, having a capacity for 20 main tracks as far as Fifty-first street and 15 tracks beyond, with no street crossings at grade, makes possible an avenue of approach to the city for the passenger trains of the railways from the east the south and the southwest that exceeds in capacity, in attractiveness of surroundings and in advantage of location, any railway entrance to a great city.

Nor are the advantages confined to the railways alone. The grouping of the passenger facilities of the railways of the south side along the shore of the lake south of Twelfth street and east of Michigan avenue, leaving all the territory between Michigan avenue and the river free, will make possible the first effective step to the extension southward of the business district of the city.

This cannot be brought about except as each individual railroad company may see its way clear to do so, and it does not seem reasonable to suppose that the Lake Shore and Rock Island companies will give up their preferential position until their present station becomes inadequate. In the meantime, the land occupied may become so valuable that its use for a railroad station would not be warranted, compared with a sale of the property and the rental or purchase of terminals elsewhere.

As the Illinois Central is required by its charter to pay to the state of Illinois 7 per cent. of its gross revenue, which is over 20 per cent. of its net earnings from operation, all rentals for terminals received by it will accrue to the advantage of the citizens of Illinois, including Chicago, which is to that extent an indirect partner. As the land set aside to the Illinois Central can be used only for railroad purposes, it is to the interest of the city of Chicago not only to favor but encourage the use of this property, relieving thereby the congestion in the territory now occupied by other railroads south of Van Buren street and between State street and the Chicago river.

The Illinois Central having signified its willingness to make provision, on reasonable terms, in its new station for the passenger service of all the south side roads, and with its main lines extending south and west to readily intercept the traffic of these roads, there appears to be no substantial reason why the grouping of the passenger terminals of the south side lines at Twelfth street and the lake front is not only feasible and practicable, but in every way advantageous to the railways, to the city, and to the community in general.

The elimination in the course of time of three of the existing passenger terminals—the Dearborn, the La Salle, and the Grand Central—would dispense with unnecessary stations and simplify the railroad situation within the business district.

With two permanent centers for the development of the railway passenger terminals of the city thus established; the one at Twelfth street and the lake front, and the one at approximately Canal and Madison streets, the distance between these terminals would be approximately one mile east and west, and one mile north and south; the location of the north terminal being at the northwest corner and of the south terminal at the southeast corner of a square mile, within which would lie the central business district of the city.

The adjustment of the routes of the surface traction lines to the simplified terminal arrangements of the railways would still further improve the situation.

To ultimately complete the system of passenger inter-communication between the railways, and to make their terminals conveniently accessible from the outlying portions of the city and suburbs, a connecting railway system could be provided of dimensions sufficient to permit the movement of standard railway passenger equipment directly between the terminal stations, with

surface outlets suitably arranged at convenient points for rail connection with the tracks of the terminal stations.

A further use of such an inner circle of communication between the railway terminals could be the extension of the suburban train service of all the roads of the city to include the circuit of the terminal stations and of the business district, thus putting every part of the city and its suburbs in direct connection with every railway radiating from the city.

Under the ordinance submitted by the Union Station Company to the city council of Chicago, the consideration of which is now pending, it is proposed to construct a new passenger terminal upon substantially the same site occupied by the existing terminal, but so greatly expanded in all its functions as to present an entirely new undertaking, nothing but the site of the old terminal being utilized in the new.

The plan of the new Union station terminal provides for the station building, a monumental structure, to be located on the west side of Canal street, occupying the entire block between Canal, Clinton, Adams streets, and Jackson boulevard, with a passage the full width of the block under Canal street to the concourse and train shed, between Canal street and the river.

(Here follows an outline of the plans proposed by the Union Station Company, which have been described in the *Railway Age Gazette* of August 23 and 30, 1912, and May 23, 1913, page 1147.)

Among the different plans and ideas for passenger terminals that have been submitted for my consideration, those presented by F. A. Delano, president Wabash Railroad; Jarvis Hunt, architect; Pond & Pond, architects; Guenzel & Drummond, architects, and the Chicago Plan Commission are the most comprehensive and are the result of much careful study and thought.

(Here follows an outline of the various plans.)

Monumental buildings of imposing design are characteristic of each of these plans, while the track layouts are indefinitely suggestive, rather than the carefully worked out systems required for successful railroad operation. All possess some ideas of merit, and the public should appreciate the time, labor and expense which have been so generously contributed in assisting in the solution of the terminal problem, by these gentlemen.

#### OBJECTIONS TO A CENTRAL UNION STATION.

Considering the fact that as a condition precedent to the creation of any union station plan the concurrence of all the railroads using it must be secured in addition to the consent of the city council of Chicago, and considering further that a large number of the railroads interested would be required to give up situations which they independently control and which are considered preferential situations, also considering their legal rights, it would seem impracticable to bring about any joint harmonious action, in the near future, on any single union station plan, even though it might be a desirable one of itself.

Ultimate accomplishment along these lines would be a matter of years of negotiations and perhaps litigation. It is reasonable to presume that in the meantime the present facilities of the Dearborn street station, the Lake Shore and Rock Island station, and the Grand Central station, will have become antiquated and outlived their usefulness, and that the railroads occupying them will have either gravitated to the Illinois Central site on the lake front south of Twelfth street, or to some new location south of Twelfth street.

A large union station located south of Twelfth street between State street and the river, even if the river could be straightened, which could not be brought about except after years of negotiation and litigation, would in a few years probably become congested, and the problem of enlargement be one of difficulty, inconvenience, and expense. It would also be an obstacle to future growth and development of the city southward, probably much more so than that now caused by the railroad holdings north of Twelfth street. It is less than 50 years since Twenty-second street was the southern limit of the city.

In the event of any or all of the south side group of railroads not being able, for reasons of policy or for any cause, to utilize the lake front terminal south of Twelfth street, any new station facilities should be confined within street building lines with either subway or elevated approaches, in such a way as to avoid blocking or interfering with streets or thoroughfares, even if separate stations for different groups of railroads were rendered necessary.

While the writer does not desire to burden this report with long arguments of a technical nature as to the question of the comparative advantages or disadvantages of a central union station for all Chicago railways, as against independent stations or separate groups of stations situated around the business center, he does desire to state that he cannot see the advantage of the former either in convenience to the public or in economy or convenience of operation to the railroads; in fact, experience in other localities would seem to show, as far as the railroads are concerned, an increase in fixed charges and expenses of operation entirely out of proportion to any material advantages gained thereby.

In Chicago a vast number of people entering or leaving the city by these railroads would be inconvenienced thereby. The traveling public passing through Chicago, and going from one railroad to another not now using the same stations, is very small, being about 2 per cent. of the total number using these stations. The business interests located in the center of the city certainly would not be benefited by the location of a union station, more difficult to access than the present ones, which would only add to the convenience of non-Chicago passengers, to the inconvenience of the greater number desiring to do business within the heart of the city.

Unless a grand central union station for all railroads in Chicago can be made more beautiful and attractive than several stations occupied by separate groups of railroads, and be more accessible and convenient to the public; occupy less space and by offering new quarters to the railroads enable them to dispose of present holdings, and open up new streets and territory for the expansion of business, there would seem to be no object in its consideration from the standpoint of the public interest. Unless a central union station would enable the railroad companies to better serve the public, increase their passenger business, reduce their operating expenses, or increase their net earnings, it would not seem advisable from a practical railroad point of view for any railroad to give up a satisfactory, convenient, preferential location.

I cannot see how a single union station, or a continuous group of adjoining stations lined up south of Twelfth street, could be convenient to that large part of the traveling public—be they through, local, or suburban passengers—which desires access to the business center of Chicago. If the present suburban stations are maintained, there is still less reason for a single union station south of Twelfth street. Nor can I see where or how such a station would relieve the present situation, unless the suburban passenger business was provided for in some manner at least as satisfactory if not more so than at present.

From a practical railroad point of view, a single union station would increase congestion, be more unsatisfactory and inconvenient to passengers, and more expensive to the railroad companies, without enough compensating features to justify its use.

*Recommendation.*—It is my recommendation that an ordinance for a union passenger terminal at the location proposed by the Union Station Company, be granted.

#### PENNSYLVANIA FREIGHT FACILITIES.

The granting of the union station ordinance, however, does not insure the construction of the passenger terminal, for the reason that the site of the proposed passenger terminal overlaps the freight facilities of the Pennsylvania, the Burlington and the Alton roads.

The ground occupied by these freight facilities cannot be vacated until other locations and facilities are provided to take the place of those to be given up; and to meet, in part, this situation, the Pennsylvania Company, operating the Pittsburgh, Ft. Wayne & Chicago Railway, has submitted for your consideration an ordinance granting to that company the rights and privileges necessary for the construction of a new freight terminal proposed to be located fronting north on West Van Buren street, covering the entire block between Jefferson and Desplaines streets, and extending southward with buildings and team tracks to Taylor street, beyond which there are further extensions for a double line of elevated approach tracks to a connection with the main line of the Pittsburgh, Ft. Wayne & Chicago right-of-way at its crossing of the Chicago river.

The general plan of this freight terminal is excellent. The location of the main freight building, fronting on Van Buren street and extending south to Harrison street, is objectionable because of the obstruction it will offer to the proposed opening of Congress street midway of the block between Van Buren street and Harrison street.

At the present time substantially all of the traffic to and from the freight terminal of the Pennsylvania Company and the central business district crosses the river on the Madison street bridge and the Van Buren street bridge, for the reason that the main driveways leading down to the freight houses and tracks of that company turn off from Madison and Van Buren streets close to the bridges and can be reached in no other direct way while the terminal remains in the present location, between Canal street and the river.

The Pennsylvania Company, in locating its proposed new freight terminal west of Canal street, evidently had in view the redistribution of this traffic by the use of Canal and Clinton streets as the main thoroughfares, tributary to which would be the bridges at Lake, Randolph, Washington, Madison, Adams, Jackson, Van Buren and Harrison streets, thus giving immediate relief to the existing congestion from the south side by spreading the traffic over eight bridges instead of two.

With the increased freight traffic thus thrown on Canal street there will be a much heavier use of the street than ever before, as it may become the main thoroughfare for heavy north and south traffic from not only the south side, but as well from the north side, and will also carry a substantial portion of west side traffic to the railway freight terminals and warehouses that may in time line Canal street on both sides from Harrison street to Fifteenth street.

To meet this situation and at the same time provide an adequate and suitable thoroughfare for the passenger traffic to and from the union station, Canal street, should be widened to 100 ft. from Twelfth street to Harrison street, and if possible further north, by extending the street eastwardly 20 ft. over railroad property and supporting it over the tracks below.

It would be advisable to reconstruct the street upon two levels, the upper level for rapidly moving through traffic, and the lower level for slow moving local traffic; the through cross streets to connect with the upper level and the short cross streets to connect with the lower level.

With these provisions for improved street traffic, the location of the Pennsylvania freight terminal west of Canal street will be of advantage by relieving the congestion in the freight yards as well as the streets, and the capacity for greatly increased business which the new terminal will afford will be of advantage to the mercantile and industrial interests as well as to the railroad.

In addition to the improvement of Canal street I would recommend the extension of Monroe street across the river, making it available as an additional continuous avenue to the west side.

I would also recommend the consideration of the widening of Harrison street in the near future.

The north line of the main freight building which it is pro-

posed to locate on Van Buren street can be set back from Van Buren street to Harrison street, and no portion of the proposed terminal should be permitted to extend north of the south line of West Harrison street widened, excepting such utilization of the property between Van Buren street and Harrison street as can be made below the level of the street grades, and without interfering with the future extension of Congress street. This can be done by the railroad company without impairing the integrity or capacity of its terminal improvements by extending the freight building southward from Harrison street to Polk street, and by using the block from Polk street to Taylor street for its team tracks, in addition to such use as may be made below street grade of the block between Harrison and Van Buren streets, as before mentioned. The two blocks thus to be occupied, from Harrison street south to Taylor street, will be equal in length to the two blocks—Van Buren street to Polk street, proposed in the original plan, and the capacity of the terminal in this location can be fully maintained.

For the proposed elevated structure to carry the freight approach tracks from Twenty-first street and Stewart avenue northward to Taylor street between Jefferson and Desplaines streets, depressed tracks should be substituted west of the Chicago river at a level that will pass under all of the intervening streets. Any disadvantage to the railroad company or shippers that may be caused by this subsurface approach is their contribution towards the future appearance of the city, and the prevention of a structure which it is considered will be unsightly to view and obstructive to the development of the west side. However, this change in track arrangement is a feasible one, and in the interests of the city should be required of the railroad company.

*Recommendation.*—It is my recommendation in respect of the proposed freight terminal of the Pennsylvania Company, that the plans relating to the elevated approach tracks and the location of the main freight building be modified as herein suggested, and the ordinance, when amended to conform to the changes specified, be granted.

#### GENERAL FREIGHT FACILITIES.

The question of some improved method of handling the enormous tonnage of freight which is shipped in and shipped out of Chicago is a very important one, when it is considered that this tonnage is largely in excess of the freight shipped into Chicago for consumption in the city. The "shipped-in shipped-out" freight is now largely handled through the streets of the business district in its movement from the railways to warehouses on its inward journey, and is again hauled through the streets from warehouses to the railway stations on its outward journey; much of it in the original form in which it was received. A great deal of the congestion of the streets in the business district of the city is due to the handling of freight which is foreign to the city, and which could with advantage to the community be handled outside of the business district.

The establishment outside of the city limits of a clearing-house for the handling of less-than-carload freight, in connection with universal freight-houses located conveniently within the city, is an advanced method of handling freight, which is worthy of the most careful investigation, as it has possibilities of great relief to the traffic upon the city streets.

With a definite trend southward of the business district of the city and the consequent advancing real estate values, it would appear reasonable that the enhanced value of the land released from railroad use north of Twelfth street on the south side that would result from the opportunity to make use of such land for the construction of commercial and office buildings, would yield returns more than sufficient to cover the expense to the railroads of moving the freight facilities now there to new locations and adopting improved methods of freight operation.

How this can advantageously be accomplished will require much careful study and extended investigation, but the benefits

that would accrue to the city by the vacation of all or even part of the railroad holdings used for freight purposes on the south side between State street and the river, in the opportunity it would give for the opening up of adequate thoroughfares and the expansion of the central business district, would justify a most comprehensive investigation.

#### HOSPITAL CAR FOR THE ROCK ISLAND.

A new feature in the safety first movement has been introduced by the Chicago, Rock Island & Pacific in the form of a hospital car, which is to be located at the scene of the track ele-



Hospital Car for the Rock Island.

vation work being done between Seventy-fifth street and the city limits of Chicago. There are some 600 men employed on this work and accidents are bound to occur. The car will be in



Receiving Room of Hospital Car, Showing Spring Cots.

charge of Dr. Anthony T. Weber, the originator of the idea. He will spend some time each day at the car giving lectures on first aid to the injured to a few picked men with a view of educating them for the "first aid" examinations of the American Red Cross Society. After they have successfully passed the examinations they will be provided with first aid kits provided by the Red Cross and assigned to different parts of the work. Each graduate will be in charge of the hospital car for a certain length of time. The lectures will also include talks on safety first, and the men receiving instructions will convey them to the rest of the men on the work and watch for unsafe conditions.

The hospital car is made from a service car 34 ft. long, the inside of which has been covered with a cloth and painted with an enamel paint. It is divided into two compartments by a screen partition. One half is provided with an operating table,

more of these cars will be built by the Rock Island, and stationed at points along the line where any large amount of construction work is being carried on.

### REMARKABLE SAFETY RECORD ON THE FRISCO.

During the month of July, 1913, the River and Cape Division of the St. Louis & San Francisco made the remarkable record of not having an employee injured with a disability exceeding three days, and there were only a very few injuries of any character. In July, 1910, there were 19 employees injured on this division; in July, 1911, 24; in July, 1912, 28. The record for 1913 is especially remarkable when it is considered that the division is over 700 miles long, and handles a very heavy traffic.



Operating Room of Rock Island Hospital Car.

wash stand, medicine chests and closets, and the other half with suspended spring beds, and a stove for heating the car. The beds are especially noteworthy, they being free to move in any direction, thereby greatly dissipating any shocks that the car may receive. They are made by the Comfort Spring Cot Company, Chicago, and are especially desirable for this work. They might also be used to good advantage in camp cars, being comfortable and sanitary. In cases of severe injury the patients will be placed in the car and rendered first aid, and the car will be taken into the city by the next ingoing train.

The possibilities of such a car are not limited to construction work. If one was placed at each division point it would be readily accessible in case of wrecks or injuries to workmen along the line who are not accessible to a hospital. It is expected that

Although the passenger traffic for July, 1913, shows a slight decrease, the freight traffic for the month in which this safety record was made shows an increase as indicated by the following table, giving the principal traffic statistics for the two periods:

	July, 1912.	July, 1913.	Inc. or Dec.
Passenger train miles...	85,292	79,660	*5,632
Freight train miles.....	78,188	80,957	2,769
Freight car miles.....	2,107,815	2,262,927	155,112
Gross ton miles .....	68,015,920	75,299,160	7,283,240

\*Decrease.

The River and Cape Division is under the jurisdiction of Superintendent O. H. McCarty, and extends from Turrell to St. Louis, including a great deal of branch mileage.



# AN ANALYSIS OF TRAIN-CREW LEGISLATION.\*

Bureau of Railway Economics Shows Proposed Laws Unnecessary; Will Not Increase Efficiency or Promote Greater Safety.

Within recent years, numerous bills to regulate the number of men that railways must employ in their train crews have been introduced in the state legislatures and in Congress. These measures are commonly known as "full-crew bills." They specify, sometimes the number of men that must be employed on passenger trains; sometimes the number of men that must be employed on freight trains; sometimes the number that must be employed in switching service; and sometimes the number that must be employed in all of these classes of service. Such measures have become laws in 20 states, namely: Arizona, Arkansas, California, Connecticut, Indiana, Maryland, Missouri, Nebraska, Maine, Nevada, New Jersey, New York, North Dakota, Ohio, Oregon, Pennsylvania, South Carolina, Texas, Washington, and Wisconsin. In some cases they merely require the employment of the number of men that it is customary for the railways to employ, existing practice not being affected. In at least 12 states these laws compel the employment of additional men. Within the last four years, eight bills have been presented in Congress, each of which would have compelled the employment of more men; but no federal train-crew law has yet been enacted.

The first efforts to secure train-crew legislation date back a number of years, and these efforts have been continued with great energy and perseverance. For example, a bill was introduced in the Massachusetts legislature in 1902 and defeated. It was again introduced in 1903 and 1904 and defeated in both years. It reappeared in 1908. On this occasion the legislature referred the whole matter to the state railroad commission for investigation. The commission, after inquiry, reported that if the officers of the railways would see that the provisions of the standard code of operating rules were enforced, and make some changes in methods locally, legislation would be unnecessary. The bill was again introduced in 1909 and defeated. It was again introduced in 1912, and this time was passed by both houses. Governor Foss vetoed it; whereupon an unsuccessful attempt was made to pass it over his veto. Later, the board of railroad commissioners issued several recommendations regarding the manning of trains, with which all the roads at once complied.

Both state and federal bills have been introduced from time to time at the instance of railway labor organizations, the chief promoter of such legislation being the Brotherhood of Railroad Trainmen. The legislative representatives of the brotherhoods have repeatedly announced that their members would vote against lawmakers who did not support the measures they demanded. Many members of the brotherhood itself have not favored, or have been opposed to, the proposed legislation. But opposition on their part is now stopped by a resolution of the brotherhood to the effect that its members cannot sign petitions against labor legislation, "nor interfere with the work of their legislative representatives, without violating the law of the brotherhood, which would mean expulsion for the offending party."<sup>1</sup>

The labor brotherhoods and the members of state legislatures and of Congress who have favored such legislation have advocated it chiefly on the ground that the employment of more men in train service is necessary to the safety of railway employees and passengers. Such legislation has been opposed by officers of the railways, by many commercial and agricultural organizations, and by many members of state legislatures and of Congress on the ground that it does not increase the efficiency or safety of railway operation or otherwise benefit the public, and hence that it does add unnecessarily to railway expenses. Therefore, railway managers have in several cases urged state governors to veto such measures. In New York and Missouri the governors, notwithstanding earnest protests from railway officers, signed

the bills as passed by the legislatures and issued statements indicating their belief that they would promote safety and were therefore in the public interest.<sup>2</sup> On the other hand, Governor Sulzer's two immediate predecessors, Governors Hughes and Dix, vetoed train-crew bills that had been passed by the New York legislature. Governor Cruce of Oklahoma, Governor Foss of Massachusetts, and Governor Harmon of Ohio also have vetoed similar bills, on the ground that general legislation requiring the railways to employ additional men on trains was undesirable. But in all except Massachusetts and Oklahoma subsequent enactments have been approved. A number of state legislatures have also refused to pass train-crew bills: of these are the legislatures of Colorado, Delaware, Florida, Georgia, Illinois, Iowa, Kansas, Kentucky, Louisiana, Michigan, Minnesota, Mississippi, Montana, New Hampshire, New Mexico, North Carolina, South Dakota, Tennessee, Utah, Virginia, West Virginia, and Wyoming.

## CHANGING CONDITIONS OF TRAIN OPERATION.

Until within a comparatively recent time trains were ordinarily made up at the point of origin by the same employees who subsequently handled them on the road. The trainmen switched the cars into place, coupled them, and did all the work necessary to prepare the train for its run, including the inspection of its condition before starting. Cars were coupled to each other and to the engine by the link and pin couplers. Brakemen had to carry links and pins to supply couplers lacking them, and to carry those unused back to the caboose or engine. Coupling had to be effected by hand, for which purpose the employees had to go between the cars. Trains were controlled entirely by hand-brakes, which had to be worked from the tops of freight cars and from the platforms of passenger cars. Practically all trains rendered local as well as through service—that is, they not only carried through traffic between large terminals, but also stopped at stations along the line to put off and take on goods or passengers. When a car was taken out of a train or taken into a train at one of these local stations, it was necessary to use the hand-brake in the switching needed to make the requisite changes. The work of trainmen at that time was hard and hazardous. The number of cars in a train was considerable. More than 30 years ago, before the introduction of air-brakes, it was the custom of many railroads to handle regularly freight trains of 40 cars or more with two brakemen. That is, the crew of a freight train, aside from employees on the engine, usually consisted of a conductor and two brakemen. The labor of controlling the train exposed the brakemen to all kinds of weather and involved strenuous physical exertion, for the application of hand-brakes sufficient to hold a train often required both strength and quickness of action. The brakemen had to spend most of their time on the tops of the cars, which in winter were often slippery with ice. Going between cars to couple by hand necessarily involved danger, so that accidents to trainmen were numerous. Passenger cars were heated by wood and coal stoves, which it was the brakemen's duty to take care of.

## DEVELOPMENT OF AIR-BRAKES AND AUTOMATIC COUPLERS.

In 1868, the first successful application of air-brakes to passenger trains was made. In July, 1886, and in May, 1887, the Master Car Builders' Association held a series of competitive trials, with the result that the air-brake was found to be as adaptable to freight trains as to passenger trains. Its use in freight service was thereafter rapidly extended. In 1893 the Railway Safety Appliance Act was adopted.

In consequence of its requirements, the use of automatic coup-

\*Abstract of Bulletin No. 53 issued by the Bureau of Railway Economics.  
<sup>1</sup>From *The Railroad Trainman*, the official publication of the Brotherhood of Railroad Trainmen, for May, 1913, p. 465.

<sup>2</sup>In Missouri the railroads circulated a referendum petition, and secured enough signatures to have the measure submitted to a vote of the people, which cannot be taken before October, 1914.

lers and train brakes has become practically universal in the United States. For the fiscal year ending June 30, 1911, there were 98.79 per cent. of the locomotives and cars fitted with train brakes and 99.56 per cent. fitted with automatic couplers. Today it is very exceptional for a train to have any cars that are not equipped with air brakes.

These improvements in equipment have had a far-reaching effect upon the work of railway trainmen. The engineer of a train, whether passenger or freight, is now its real brakeman and, save under exceptional conditions, sets and releases the brakes from his cab on the engine. The "brakemen," so called, seldom have anything to do with the brakes except on detached cars during switching operations. Indeed, the term "brakeman" is now a misnomer and is being displaced in railway usage by the term "trainman." The general substitution of the automatic coupler for the old link and pin has changed the character of the trainman's work in coupling and uncoupling and has very greatly diminished the hazard. Indeed, railway managers claim that, if the trainmen comply with their instructions, the hazard is eliminated entirely. Formerly, when coupling cars, the brakeman had to stand between the cars at the moment of their coming together in order to guide the link into its place. This entailed great risk of having his hand crushed, as well as of being thrown down and run over. Now, any necessary adjustment of the coupler can be made, and ought to be made, before the cars are put in motion to effect the coupling. Formerly, when uncoupling, the brakeman had to stand between the cars to remove the pin. Now, the pin that locks the coupling can be removed by a rod extending to the side of the car. Thus during neither the coupling nor the uncoupling does the trainman need to stand between the cars. These changes apply to both freight and passenger cars. How greatly they have reduced the hazard of coupling and uncoupling cars is indicated by the following table:

CASUALTIES TO TRAINMEN FROM COUPLING ACCIDENTS 1890 AND 1910.

Year.	Total number of trainmen.	Total killed.	Total injured.	Number killed for each 10,000 trainmen.	Number injured for each 10,000 trainmen.
1890.....	153,235	265	6,073	17	400
1910.....	318,632	174	2,826	5	88

In addition to the changes in their work directly resulting from the introduction of air-brakes and automatic couplers, there have been other modifications in the duties of trainmen which may be briefly noted. In the first place, the train crew as a rule no longer makes up and inspects the train at terminals. Switching crews now make up all trains at all important points of origin and, after they have been inspected by inspectors employed for that purpose, deliver them to the train crew ready for operation. The train crew has no more to do with the preparation for the run than to test the brakes. At the end of the run the train crew has only to deliver a train to the switching crews, which separate the cars for further disposition.

Again, the trainman's duties on passenger trains are less arduous because passenger trains are now almost universally heated with steam or hot water from the engine, and the trainman has only to regulate the degree of heat. The gradual displacement of the oil lamp by gas and electric lighting has relieved the trainman of many former duties.

INCREASE IN TRAINLOADS.

Coincident with the development of safety appliances on trains, there has been a steady and rapid increase in the length and load, particularly of freight trains. Generally speaking, transportation is conducted most economically when traffic is handled in the largest units. The larger the loads per car and per train, the less the relative investment that must be made in roadway, track, and equipment, and the less the relative expenditures that must be made for maintenance of way and equipment, and for conducting transportation.

The greatest economies have been secured by increasing the number of tons hauled per train, and by increasing the amount of traffic handled in proportion to the number of men employed.

The extent to which, in their efforts to handle traffic economically, the railways of the United States have increased their trainloads is indicated by the fact that the average number of tons per train in this country in 1890 was 175; in 1900, 271, and in 1910, 380. In the region of heaviest traffic, that comprising in general the States of New York, Pennsylvania, New Jersey, Delaware, and Maryland, the average number of tons per train increased from 218 in 1890 to 502 in 1910. On some lines the average trainload exceeds 1,100 tons; trainloads of minerals ranging from 3,000 to 5,000 tons are not uncommon, and sometimes a train has as many as 6,000 tons. These heavy increases in train loads have been effected very largely by increasing the capacity of cars and their loading, and by increasing the number of cars in a train. The average capacity of a freight car in this country increased from 28 tons in 1902 to 36 tons in 1910. Loaded freight trains often contain 50 to 75 cars, and trains containing even larger numbers of empty cars and exceeding a half mile in length are run not infrequently in some parts of the country.

There has been no such corresponding increase in the length of passenger trains, although passenger trains on main lines are somewhat longer than they were in past years. Often 12 to 16 and even more cars are pulled by a single engine; the passenger cars have increased in size and especially in weight.

With this increase in car loading and train loading has been a decrease in the number of men required to handle a given amount of traffic. It has not, however, been accompanied by a decrease in the total number of trainmen, for, as is shown later their number has increased from 1901 to 1910 at a greater rate than the car mileage or the train mileage.

TRAIN CREWS UNDER PRESENT CONDITIONS.

The number of men employed on passenger trains varies with conditions. On many local trains containing only two or three cars the crew behind the engine consists merely of the conductor, acting also as baggagemaster, and one man who serves as brakeman or flagman.

Throughout the country on trains of four or five cars, the crew customarily includes conductor, baggagemaster, brakeman or flagman, and frequently a porter; there are additional brakemen for trains with greater numbers of cars. The brakemen on passenger trains announce stations, help the passengers as they get on and off, set switches, load and unload baggage, look out for hot boxes and other defects, and flag. When there are both a porter and a flagman or a brakeman and a flagman, as is the case on most main-line passenger trains, the flagman's sole duty is to flag and to set switches behind the train.

The object of many of the legislative enactments affecting train crews in passenger service is to require the employment on every passenger train, whatever its length, in addition to the men on the engine, of at least a conductor, a baggagemaster, and a brakeman or flagman; and to require still other men on trains exceeding certain specified lengths. For example, a bill introduced in Congress in 1909 provided that the crew of a passenger train having three cars or less must include a conductor, a baggagemaster, and a brakeman. This would have made it necessary to add a baggagemaster on many short branch-line trains carrying at present only a conductor and a brakeman; and in many cases in the South either to add a brakeman or to substitute a brakeman for the porter. The same bill provided that the crew, on trains of three cars or more, include at least a conductor, a baggagemaster, and two brakemen. This would have made necessary the employment of an additional man on many trains. The law in Nevada requires two brakemen on trains of three or more cars; the laws in New Jersey, Oregon, Pennsylvania, Washington, and Wisconsin, on trains of four or more cars; the law in Indiana, on trains of five or more cars, and the law in Nebraska, on trains of six or more cars. Under the New Jersey law there must be at least six trainmen on every train containing a baggage car in addition to four or more passenger cars, and under the New York law every train having a

baggage car must have a baggageman in addition to the engineer, fireman, conductor, and two brakemen.

These laws prescribe the number of trainmen according to the number of cars in the train. But the necessity or occasion for having more rather than fewer trainmen is not necessarily determined by the number of cars. A great many trains carry Pullman cars, on which there are Pullman conductors and porters to assist passengers and to look after the heating and lighting and ventilation of their respective cars. In such cases, there is no need for as large a regular train crew as in the case of trains of the same length carrying no Pullmans. And yet the laws make no allowance for the service of the Pullman porters. Such laws appear especially illogical in the case of trains composed exclusively of Pullman cars.

On a through freight train there are usually five men—an engineer, fireman, conductor, and two brakemen—one of the brakemen sometimes being called a "flagman." At the point of origin the train, made up and ready for its run, is delivered by a switching crew to the train crew. The place of one of the brakemen is on the engine, the other goes into the caboose with the conductor. The ordinary duties of the forward brakeman are to transmit signals from the conductor to the engineer and to open switches in front when it is necessary for the train to go on a siding at a meeting point. The ordinary duties of the rear brakeman are to flag at the rear end of the train when it stops and to close switches behind the train when it has gone on a siding. In an emergency caused, for example, by a draw-bar pulling out or the air-hose parting, the conductor may need the direct assistance of one of the brakemen. In that case the rules require the rear brakeman to flag the rear of the train and the fireman to flag the front of the train, while the forward brakeman assists the conductor. In these very rare cases, the fireman may be used to protect the front of the train, because at such times he is not performing any other duties. Failures in the braking apparatus that cannot be promptly remedied on the spot are ordinarily due to something that has happened in or to the engine. In this case the train moves slowly and under control to the next station, where it is held until another engine is supplied.

In addition to the air-brakes, all freight cars are still equipped with hand-brakes. These hand-brakes are not worked by employees on through freight trains in the ordinary course. They are resorted to only in case the air-brakes fail, or under especial conditions, such as going down steep grades. When hand-brakes are used on such heavy grades as, for example, on some parts of the New York Central lines, it is the usual custom to employ three or more brakemen on through freight trains. As a general rule, the duties of brakemen on through trains, between terminals in non-mountainous territory, are confined to throwing switches, flagging, and assisting the conductor in examining the running gear. On arrival at the terminal, the signal lamps are put away and the caboose locked up by the train crew, and the train is turned over to the regular yard switching crew.

While it is the general custom to employ two brakemen on a through freight train, it is usual to employ three or more brakemen on a local freight train, notwithstanding that local trains have fewer cars. This is not to serve the need for safety, but to expedite the service. Local trains set out and pick up cars at way stations, and load and unload a great deal of less-than-carload freight. Hence there is much switching to be done and much handling of freight at way stations, and the additional brakemen are ordinarily necessary that the trains may not be unduly detained. Similarly, three brakemen are usually employed on a train switching cars to and from industrial tracks.

So far as freight-train service is concerned, the purpose of train-crew legislation usually is to require the railways to employ at least three brakemen on a through freight train. As has been said, it is standard practice to employ at least two brakemen on every through train and at least three brakemen on every local train. Following is a list of the states in which laws

have been passed requiring three brakemen on trains and specifying the minimum number of cars to which this requirement shall apply: Arkansas and Washington, 25 cars or more; New York, 26 cars or more; Maryland, New Jersey, and Pennsylvania, 30 cars or more; Arizona, Missouri, and Oregon, 40 cars or more; California, Nevada, and Indiana, 50 cars or more; North Dakota, 46 or more cars. The bills that have been introduced in Congress usually have required three brakemen on every train containing 25 cars or more.

Here, again, it will be seen that the laws prescribe the number of trainmen on the basis of the number of cars in the train. From what has just been said of the character of the work to be done on through and local trains, it is evident that the number of cars in a train is not the logical basis for the determination of the size of the train crew.

EFFECTS OF TRAIN-CREW LEGISLATION.

It is obvious that an increase in the number of men in a train crew means an increase in the operating expenses and, unless accompanied by a corresponding increase in the traffic per train or in rates, means a decrease in net operating revenues. The railways are reporting to the Special Committee on the Relation of Railway Operation to Legislation careful estimates of the additional expense resulting from state legislation already enacted. At the time this bulletin goes to press, that committee had not received estimates from some of the largest lines. However, the estimates that have been reported up to this time are given in the following table as a partial indication:

ESTIMATES OF ADDITIONAL ANNUAL EXPENSE TO THE RAILWAYS IN CERTAIN STATES, SO FAR AS REPORTED TO OCTOBER 1, 1913, RESULTING FROM TRAIN-CREW LAWS ENACTED BY THOSE STATES.

Arkansas .....	\$179,085
California .....	66,297
Indiana .....	244,052
Maine .....	602
Maryland .....	96,921
Missouri (a general estimate).....	500,000
Nebraska .....	24,367
New Jersey .....	381,851
New York .....	854,016
Ohio .....	139,592
Oregon (O. R. & N. Co. alone).....	47,000
Pennsylvania .....	1,211,233
Washington .....	158,026

Total, reported to date.....\$3,903,042

Considering the number of railways not represented in these estimates, and the importance of some of them, it is not improbable that the additional annual expense to the railroads in the above-named states on account of the train-crew laws enacted by these states will amount to \$6,000,000.

These estimates apply to the expense to the railroads on account of train-crew laws enacted in only a limited number of states. But the full effect can be seen only from estimates that apply on account of all such laws to all the railways in the United States. Four train-crew bills were introduced in Congress in 1909 and 1910. The Special Committee on the Relation of Railway Operation to Legislation made inquiries early in 1910 of all the railways as to the cost to them of complying with these federal bills, if enacted, as well as the expense they were being put to on account of state legislation then in force in 13 states. The following table is a summary of the replies received:

Estimate of 1910.	Number.	Mile-age.	Amount of additional annual cost of compliance with full-crew bill.
Roads replying .....	166	205,547	\$18,328,302.32
Estimated for other roads, exclusive of Canadian and Mexican roads.....	126	23,254	1,953,336.00
Total .....	292	228,801	\$20,281,638.32

Another bill was introduced in Congress in 1912 which required that on each freight train containing 25 or more cars the crew shall consist of at least an engineer, a fireman, a conductor, and three brakemen, "regardless of any modern equipment of automatic couplers and air-brakes." This bill made no reference to passenger-train crews. As a result of inquiries made of the railways by the Special Committee on Relations of

Railway Operation to Legislation, in connection with this proposed federal law, a compilation was made from the replies received from 143 operating companies.

This compilation shows that, according to the estimates of these 143 railways operating approximately 85 per cent. of the steam railway mileage of the country, the additional cost to them of complying with the proposed federal bill in states where train-crew legislation is already in operation would amount to \$1,342,237.17 per annum, or approximately 75 per cent. of the cost of compliance with state laws already in effect. The estimated cost to them of compliance with the proposed federal act in states where there was no train-crew legislation was \$10,255,790 per annum; the estimated cost to them of compliance with state laws then in effect was \$1,797,589.94; making the total estimated expense of these 143 companies for federal and state legislation to be \$13,395,617.

However, the fact that such train-crew legislation increases operating expenses is not a conclusive argument against it. The legislation, presumably, is intended to promote the interest of the public, and the question at issue is whether there are benefits directly or indirectly conferred on the public, and, if so, are they commensurate with the expense incurred.

#### ISSUES INVOLVED IN TRAIN-CREW LEGISLATION.

In order that the arguments in favor of train-crew legislation may be fairly presented, it is desirable to give the fullest consideration to any statement from an authoritative source. To this end a thorough search has been made throughout the existing body of railway literature, throughout the reports of hearings before the Committees of Congress, and recent issues of *The Railroad Trainman*, the official organ of the Brotherhood of Railroad Trainmen. An effort was made to secure reports of hearings before state legislatures also, but without success, except in the case of Kansas. On account of the paucity of available data, of precise and specific character, supporting the trainmen's side of the case, a copy of the first page proof of this study was sent to each of the presidents of the four railway brotherhoods, with a letter inviting their criticisms and suggestions and expressing an especial desire to receive further concrete and definite information. But this effort has not elicited any further data. The only arguments containing definite statements why extra crew legislation should be enacted that have been found are embodied in a statement by W. G. Lee, President of the Brotherhood of Railway Trainmen, quoted in the *Metropolitan Magazine* for June, 1913, and in a statement made by A. A. Roe, representing the Brotherhood of Railway Trainmen at a hearing held in 1911 by a committee of the Kansas legislature.

Mr. Lee's statement is as follows:

The necessity for such legislation arose out of the practice of the railway companies reducing the number of men to an extent considered unsafe by the employees. Some years ago certain railways reduced the number of freight trainmen to one, whose duty was to flag, leaving the work of running and looking after the train to the conductor.

Further necessity (for such legislation) arose through increased tonnage and fewer men employed, which was made possible by safety appliances and heavier equipment. The railways assumed the position that as trainmen no longer had to control trains by hand-brakes they were unnecessary. The heavier demands for increased tonnage placed on trainmen in other ways were not considered. On the majority of our railways freight trains are composed of 50 to 100 cars; they are from half a mile to a mile in length. Such trains must be carefully inspected at water tanks and other stops. They require extra care in handling, particularly in crossing over to permit superior class trains to pass. If switching is to be done, and less than three men are employed, it leaves this work to be done by one man under conditions most dangerous to himself and the traveling public, particularly when the work is done at night.

Railway companies have forced men to work under unsafe conditions, with the result that hundreds are disabled or killed every year. Our brotherhood paid one claim for every 67 members in the year 1912, which is evidence that train service is most hazardous.

Statement is made that extra men have not prevented wrecks. No one can speak advisedly on this subject. Wrecks that are prevented do not figure in the statistics.

Railway managers rest their case on the statement that full-crew legislation will not prevent wrecks. Employees, speaking from daily experience, contend that it will make wrecks less frequent than they otherwise would

be, and that it will increase the personal safety of employees and the public. Managers argue that such legislation would put an unnecessary cost on the public. Employees point to the fact that every six minutes, day and night, year after year, one of their number is killed or injured. In the name of humanity they ask from the state the protection denied them by the company.

This statement by the official head of the trainmen's organization appears to contain two definite points: 1. The adoption of safety appliances and the increase in trainload has resulted in a reduction of the number of trainmen relative to the work to be done. 2. This reduction in the number of trainmen has increased the risk both to the trainmen and to the public and consequently the number of casualties in train service.

In his argument before the committee of the Kansas legislature, Mr. Roe specifically disclaimed that the efforts to obtain train-crew legislation were prompted by any desire to secure a reduction in the work performed by any trainman, or that if enacted it would result in any such reduction in their work. He based his argument entirely upon the ground of safety, stating that there are occasions when an additional man is needed to ensure the accurate and prompt transmission of signals between the conductor and the engineer, and that there are occasions when the protection of the rear of the train requires an additional man.

In the argument that an additional man is sometimes needed to transmit signals he instanced cases where in the absence of such a man there might be an accident, but did not cite any specific accident as having been due to this cause. His examples to show the need of another man to protect the rear of the train were no more concrete, and he admitted that there was no work for an additional man to do when the train was running between stations.

#### NUMBER OF TRAINMEN FOR WORK PERFORMED.

Available statistics on the question of fact in the first point made by Mr. Lee may now be noted. It is difficult to present any official statistics that will determine with absolute accuracy the relation of the number of trainmen to the work performed.

In the case of through trains it is difficult for the railways to discover any duties for a third brakeman that could not be performed easily by other members of the crew. One duty frequently suggested, but not mentioned by Mr. Lee in his statement in the *Metropolitan Magazine*, is that a third brakeman is needed to ride on the top of the train. Except on mountain grades, where a third brakeman is provided, he is not needed on top of the train to manipulate the hand-brakes; and even although he might possibly at times be useful in that position to transmit signals to the engineer, it is the experience of operating officers that no discipline has yet been devised sufficiently severe to keep him there.

In this connection Mr. Lee voices the complaint that the longer trains and heavier equipment have increased the responsibility of trainmen in the inspection of the trains when stops are made at coaling and water stations. It has already been noted that the train crews no longer make the careful and detailed inspection of cars at the terminals before setting out upon their run. This work is now done by special employees at the terminals. But each train crew is required to keep a look-out en route for such faulty conditions as hot boxes, broken couplers, broken brake-gear, and the like. The rules governing such observation of the train differ on different roads. But, in a general way, the requirement is that whenever trains stop at coaling and water stations the trainmen shall examine the train for the purpose of detecting any such defects. Sometimes, when the conditions are favorable, or when the occasion requires a more careful observation, the forward brakeman walks down one side of the train while the conductor or a rear brakeman walks up the other side until they are directly opposite to each other. They then cross over, and the rear brakeman inspects the other side to the rear of the train in going back to the caboose, while the forward brakeman looks over the other side to the front of the train in going back to the engine. But the ordinary conditions of train operation do not require such an

examination. It is not necessary, except after a train has undergone some special strain, as when passing over a heavy grade, or making an uncommonly fast run, or when it is about to be placed under some such unusual stress. The customary practice is for the forward brakeman to watch the train as it pulls by, then to climb on the caboose and walk over the train to the engine, continuing the examination as he goes.

It is conceivable that additional men in the crew could reduce the time and labor required for the more careful examination first described, or could permit it to be made in a greater number of cases. But opportunities for such observation in the case of through trains are few because the stops are infrequent, and the number of men always on local trains is sufficient to make any needed examination. Therefore, the practical effect of a larger crew upon the number or the carefulness of these so-called "inspections" of trains on the road would be very small.

The following table, drawn from the annual statistical compilations of the Interstate Commerce Commission, is presented for the purpose of showing as accurately as possible the relation of the increase in the number of trainmen to the increase in work performed between the years 1901 and 1910. The term "trainmen" as here used includes enginemen, firemen, conductors, and all other men employed on trains for the purpose of their operation; the term "other trainmen" as here used includes all trainmen except enginemen, firemen, and conductors.

	1901.	1910.	Increase.	Per cent. of increase.
Total train-miles, revenue service.	908,092,818	1,221,852,647	313,759,829	34.55
Freight car-miles, revenue service.	12,832,092,209	18,981,573,779	6,149,481,570	47.92
Total number trainmen	209,043	318,632	109,589	52.42
"Other trainmen"	84,493	136,938	52,445	62.07

These statistics show that while train-miles have increased over 34 per cent. between 1901 and 1910, and freight-car miles about 48 per cent., the number of trainmen employed has increased over 52 per cent. and of "other trainmen," largely brakemen and flagmen, 62 per cent. It has already been noted that the number of trainmen in proportion to the tonnage handled has decreased. But, since the trainmen's work is with cars and trains, rather than with tons carried, car-miles and train-miles are a much better index of the amount of their work.

TRAIN-CREWS AND ACCIDENTS.

In order to reach a conclusion as to whether accidents to trainmen have increased in recent years as a result of more economical methods of operation, it is desirable in the first place to analyze, so far as the statistics will permit, the causes of accidents to trainmen. In the first place, Mr. Lee's statement that the Brotherhood of Trainmen paid one claim for each 67 members in 1912 is apt to be misleading. It implies that this proportion of claims was due to accidental causes; but a hasty

check shows that of the claims paid in 1912 no less than 48 per cent. were ascribed to natural causes and only 52 per cent. to accidental causes. Based on the average membership for the year, the claims paid that were due to accidental causes thus numbered only one for each 119 members.

Turning to the official statistics of the Interstate Commerce Commission, the accompanying table, compiled by the accident division, shows the casualties to trainmen classified according to the causes, as reported by the railways in their monthly returns to the commission.

It will be seen that a large proportion of the accidents to trainmen were due to their being struck or run over by engines or cars, falling from cars or engines, coming in contact with overhead or lateral obstructions, or that they occurred while getting on or off cars or engines. Of the total casualties in 1912, 50.4 per cent. of those that were fatal and 34.1 per cent. of those entailing injury were so caused.

While it may be conceivable that an indirect connection might be shown between some of these accidents and a supposedly insufficient number of employees on the train, such a connection seems remote and cannot be established by any existing information. It does not seem clear that an increase in the number of employees would tend to reduce such accidents as these. Rather might it be assumed that an increase in the number of trainmen would tend to increase the number of such accidents.

This conclusion seems to be well supported: An analysis of the causes of accidents to trainmen indicates little or no possibility that larger crews would reduce the risk of accident to trainmen.

Turning to train accidents proper, the important causes are collisions and derailments. The Interstate Commerce Commission makes the following classification of the causes of derailments occurring in 1912:

	Number
Derailments due to defects in roadway, etc.	1,877
Derailments due to defects of equipment	3,847
Derailments due to negligence of trainmen, signal men, etc.	423
Derailments due to unforeseen obstructions of track, etc.	412
Derailments due to malicious obstruction of track	75
Derailments due to miscellaneous causes	1,581
<b>Total</b>	<b>8,215</b>

Out of the 8,215 derailments reported, only 423, the number attributed to "negligence of trainmen, signal men, etc.," can be specifically connected with the train crews. The language used by the commission does not imply that any of these derailments could be attributed to too few men in train crews. It rather implies that they were due to the "negligence" of those who were so employed. It is of course conceivable that defects in equipment might have been noted and derailments avoided had the crew been larger; but this is an assumption which cannot be sustained by any evidence that has been found.

TABLE 1.—CAUSES OF ACCIDENTS TO TRAINMEN DURING FISCAL YEAR 1912.

	Trainmen.		Trainmen in yards.		Yard trainmen.		Total.	
	Killed.	Injured.	Killed.	Injured.	Killed.	Injured.	Killed.	Injured.
<b>I.</b>								
<i>Casualties in connection with train operation, but not in train accidents.</i>								
Being struck or run over by engine or car at stations or yards	62	112	80	187	100	325	242	624
Being struck or run over by engine or car at other places	60	80	1	1	2	8	63	89
Falling from cars or engines	178	2,173	56	1,131	122	2,062	356	5,366
Coupling or uncoupling	50	852	37	510	98	1,802	185	3,164
Getting on or off cars or engines	55	3,162	21	1,480	33	2,841	109	7,483
While doing other work about trains (not in shops or engine houses) or while attending switches	55	10,876	28	3,610	39	4,787	122	19,273
Coming in contact while riding on cars with overhead bridges, tunnels, or any fixed structure above or at side of track	45	635	7	297	17	540	69	1,472
Other accidents on or around trains not here mentioned	...	14	...	14	...	11	...	39
Accidents to railway or bridges not causing derailments, such as fires, floods, landslides, explosions, etc.	...	12	...	3	...	...	...	15
Being struck or run over by engine or car at highway grade crossings	...	107	...	58	...	86	...	251
Other causes	5	107	1	58	...	86	6	251
<b>Total</b>	<b>510</b>	<b>18,023</b>	<b>231</b>	<b>7,291</b>	<b>411</b>	<b>12,462</b>	<b>1,152</b>	<b>37,776</b>
<b>II.</b>								
<i>Casualties in train accidents.</i>								
Collisions	186	1,740	26	526	37	463	249	2,729
Derailments	191	1,610	7	134	21	222	219	1,966
Bursting of, or defects in, locomotive boilers or boiler attachments	27	601	1	146	8	114	36	861
Accidents to trains, cars, or engines, except collisions, derailments, and boiler explosions	3	416	...	105	4	122	7	643
<b>Total</b>	<b>407</b>	<b>4,367</b>	<b>34</b>	<b>911</b>	<b>70</b>	<b>921</b>	<b>511</b>	<b>6,199</b>
<b>Grand total</b>	<b>917</b>	<b>22,390</b>	<b>265</b>	<b>8,202</b>	<b>481</b>	<b>13,383</b>	<b>1,663</b>	<b>43,975</b>

ACCIDENTS TO TRAINMEN FROM 1901 TO 1912.

In connection with Mr. Lee's assertion that casualties to trainmen are in part due to the insufficient size of the train crew, and his implication that casualties are increasing, it is of interest to examine the statistics of casualties to trainmen from 1901 to 1912, classified by their causes, here shown in Table II. These statistics compiled by the Interstate Commerce Commission are not wholly comparable, as certain changes have been made in the classification of accidents during the period. Moreover, the statistics from 1901 to 1910 are taken from the annual reports of the railways to the commission, while those for 1911 and 1912 are from the annual summary of the monthly reports of accidents, annual reports of accidents having been abandoned in 1910. Because of the fact that for the last two years here presented the reports are made by the railways to the commission monthly instead of annually, and because the inspection of accidents has been more rigorous, the statistics for these last two years have doubtless been more complete; this will probably account, in considerable part, for the striking increases in the number injured. It should be noted, further, that while the number of injuries considerably increased from 1901 to 1904, they then did not vary greatly year by year until 1911, when they again appear to increase (due in part, as already noted, to more complete reports). The number of deaths, taking the period as a whole, was about the same for each year.

During the ten years, 1902-1912, the Interstate Commerce Commission investigated directly through its own agents 1,431

Fault of dispatchers, operators, etc. (Continued):		Number
Signal incorrectly set	.....	60
Switch misplaced	.....	59
Other errors	.....	2
<b>Total</b>	.....	<b>277</b>
Fault of other employees.....		18
Mechanical defects:		
Defective or weakened track.....	.....	59
Defective or weakened equipment.....	.....	96
Failure of air brakes.....	.....	30
Failure of block signals.....	.....	4
<b>Total</b>	.....	<b>189</b>
Parting of trains.....	.....	11
Hostile weather conditions.....	.....	68
Malicious interference with track or equipment.....	.....	41
Miscellaneous causes.....	.....	35
Causes uncertain or unknown.....	.....	72
<b>Total</b>	.....	<b>1,431</b>

ACCIDENTS TO LONG FREIGHT TRAINS.

The argument that more than two brakemen should be employed on long through trains in the interest of safety implies that these trains are more liable to accidents than short local trains with three brakemen, and that the third brakeman should be employed on through trains to reduce this liability. In this connection may be quoted statistics compiled by C. W. Kouns, general manager of the Atchison, Topeka & Santa Fe Railway's eastern lines, presented to the Joint Railroad Committee of the House and Senate of the Kansas Legislature last winter. Mr. Kouns said:

The Missouri, Kansas & Texas report, covering three divisions, shows 2,718 trains run. Of this number, there were 79 accidents to trains carry-

TABLE II.—CASUALTIES TO TRAINMEN, 1901-1912.

Year.	Collisions and derailments.		Coupling and uncoupling.		Falling from and jumping on or off trains, locomotives and cars.		Struck by trains, locomotives, or cars.		Overhead obstructions.		All other causes.		Total.	
	Killed.	Injured.	Killed.	Injured.	Killed.	Injured.	Killed.	Injured.	Killed.	Injured.	Killed.	Injured.	Killed.	Injured.
1901.....	464	2,508	163	2,377	441	5,130	255	574	48	457	166	5,669	1,537	16,715
1902.....	534	3,350	141	2,475	449	6,502	256	739	78	664	216	7,773	1,674	21,503
1903.....	648	4,526	211	3,023	541	7,324	367	824	82	656	221	9,323	2,070	25,676
1904.....	613	4,337	269	3,506	573	8,683	357	920	75	840	227	10,989	2,114	29,275
1905.....	579	4,736	217	3,316	526	8,443	365	866	59	839	244	11,653	1,990	29,853
1906.....	693	5,245	266	3,590	584	10,024	428	931	82	1,042	257	14,157	2,310	34,989
1907.....	776	6,273	272	4,062	644	11,394	475	1,171	91	1,017	279	16,838	2,537	40,755
1908 <sup>1</sup> .....	480	4,759	198	3,115	516	10,280	358	902	72	914	218	15,850	1,842	35,821
1909 <sup>2</sup> .....	389	3,159	137	2,271	379	8,568	243	577	47	775	149	13,768	1,344	29,118
1910 <sup>2</sup> .....	500	4,296	174	2,826	442	10,407	363	924	55	875	189	16,513	1,723	35,841
1911 <sup>2</sup> .....	480	4,241	198	2,898	451	11,902	302	682	71	1,454	206	19,831	1,708	41,008
1912 <sup>2</sup> .....	468	4,695	185	3,164	465	12,849	305	713	69	1,472	171	21,082	1,663	43,975

<sup>1</sup>Does not include accidents reported by switching and terminal companies.

<sup>2</sup>Data for these last two years are more exact and more complete than for previous years. This fact alone would cause an apparent increase in the number of casualties. It will be noted that from the year 1904 to 1910 the number of casualties fluctuates about a fairly constant level. As pointed out in the text, the large number of the casualties to trainmen are due to causes which have little or no connection with the number of trainmen employed.

train accidents, which were responsible for the death of 3,447 persons, or about one-third of the total number killed in such accidents during this period, and the injury of 18,908 persons, or about one-eighth of the total number injured in such accidents during this period.

The following tabulation shows the causes to which the commission attributed these 1,431 train accidents:

CAUSES OF PRINCIPAL TRAIN ACCIDENTS ON RAILWAYS OF UNITED STATES, FISCAL YEARS 1902 TO 1912, INCLUSIVE.

	Number.
Fault of train crew other than brakemen:	
Disobedience of rules or orders.....	63
Misread orders.....	69
Ran past signal.....	66
Ran past meeting point.....	36
Carelessness.....	95
Forgetfulness.....	49
Asleep.....	40
Intoxication.....	5
Failure to follow schedule.....	16
Excessive speed.....	137
Other errors.....	1
<b>Total</b> .....	<b>577</b>
Fault of brakemen:	
Failure to set brakes.....	40
Failure to flag.....	72
Improper flagging.....	26
Other errors.....	5
<b>Total</b> .....	<b>143</b>
Fault of dispatchers, operators, etc.:	
Wrong orders.....	89
Failure to deliver orders.....	67

ing more than 25 cars and 119 to trains carrying less than 25 cars. In other words, under the first item there was one accident to every 345 trains, while the second shows one accident to every 179 trains.

On the Union Pacific, in Kansas, during January, 1913, there were five accidents; all to trains having less than 25 cars. There were 873 such trains, so that the rate was one for each 175 trains run. They ran during the same period 644 trains with over 25 cars without accident.

On the Atchison, Topeka & Santa Fe, from August, 1912, to January 31, 1913, there were 19,407 trains run with 25 cars or less. There were 128 accidents to these trains, or one to every 152 trains run. There were 22,348 trains run with more than 25 cars. There were 123 accidents to these trains, or one to each 182 trains run.

A significant fact in connection with these accidents is, that while a large per cent. of the smaller trains were equipped with an additional man, 61 of the 128 accidents were due to errors of employees. On the heavier trains, and grater total number run, there were but 44 due to that cause.

The Chicago, Rock Island & Pacific, reporting for six months ending December 31, 1912, shows 56 accidents to trains having less than 25 cars, or one for each 103 trains run, and 88 accidents to trains having more than 25 cars, or one for each 122 trains run.

They also show a much larger number of accidents due to errors of employees on the smaller trains than the large ones; the figures being 54 on the smaller and 17 on the larger trains.

While the available evidence is not finally destructive of the claim that a number of the accidents in train service is due to the employment of too few men, yet the presumption from all the evidence is so strongly to the contrary that it throws the burden of proof upon those who make the statement. Thus far they have presented no specific evidence in support of their contention.

On the other hand, it is the unanimous opinion of railway

operating officers that an increase in the number of men normally employed on trains will tend to increase the number of accidents not only to individual employees, but to the trains themselves. It will either result in a dangerous division of responsibility or else in an idle and unnecessary man becoming a hindrance to other employees in the performance of their duties.

#### ACCIDENTS TO ALL PERSONS.

Larger train crews are urged, not only in behalf of the safety of trainmen, but also for the further reason that they would increase the safety of the traveling public and of railway employees other than trainmen. With respect to that claim, an analysis of the causes of accidents to railway employees, passengers, trespassers, and other persons shows that more than half of the casualties to passengers are due to collisions and derailments, which have been considered. As to the other casualties, there is no indication that the size of the train crew was a factor in their cause.

#### TRAIN-CREW LEGISLATION AS AFFECTING THE PROVISION OF SAFETY APPLIANCES.

There is another side to this question of the effect of full train-crew laws on safety. If it be admitted that train-crew legislation is unnecessary, it must then be granted that such legislation not only will not promote safety, but may by reason of its expense be an actual obstruction in the way of the development of greater safety of the railways of the country. The Interstate Commerce Commission has frequently called attention to the need for physical improvements. In its annual report for 1912 it directs attention to conditions of track and equipment that lead to derailments, and recommends the universal installation of the block system as a means of reducing collisions. The improvement of track and equipment and the installation of block-signal systems and other physical improvements can be made only by the investment of a large amount of capital. As has been shown, the railways estimate that train-crew legislation applying throughout the country would increase railway expenses to the extent of from \$13,000,000 to \$20,000,000 per year. The former amount is the annual interest at 5 per cent. on \$260,000,000; the latter on \$400,000,000. It has been estimated by the Special Committee on the Relation of Railway Operation to Legislation that for \$260,000,000 block-signal systems could be installed on all railway mileage of the United States not now so equipped—in other words, train-crew legislation would cost the railroads at least as much as the universal installation of the block-signal system.

Railway officers contend that net earnings are insufficient even now to enable them to make these needed physical improvements.

**NIGERIAN RAILWAYS, AFRICA.**—The details of the scheme for the development of the railways of Nigeria, Africa, have now been sanctioned by the British government. The terminal point of the line, which will be some 400 miles in length and will probably take three years to construct, has been fixed at Port Harcourt at the head of the Bonny estuary, which will be called Port Harcourt. From Port Harcourt the line, which is called the New Eastern Railway, will run through the Central province, traversing a rich and populous district, to the coal fields near Udi, a distance of 120 miles. Thence it will run to the Benue river, crossing that stream by an important bridge a little below Abinsi. It will next run to the neighborhood of Jemaa, in the tin fields (to which a branch line may be subsequently constructed), and thence to the point at which the existing line crosses the Kaduma river. There a junction with the Kano-Lagos-Baro system will be effected. The bar at Bonny is said to be the best in British West Africa, affording a depth of 23 feet at high water, and any vessel that can enter the Bonny estuary can reach Port Harcourt. Construction on the new line will be started without delay and pushed forward as rapidly as possible.

## RAILWAY ELECTRICAL ENGINEERS' ASSOCIATION.

The sixth annual convention of the Association of Railway Electrical Engineers was held in the LaSalle Hotel, Chicago, October 21 to 24, D. J. Cartwright, electrical engineer, Lehigh Valley, presiding. Extracts of some of the more important papers follow:

#### HEAD END EQUIPMENT.

It is the opinion of the majority of the committee that a metallic hose between locomotive tender and dynamo car with a positive connection lock will give the most satisfactory and economical results when properly installed and maintained. It is absolutely necessary that the metallic hose installation be correct in every detail, including the location of the train line piping, location and angle of elbows, length of nipples in the hose, and a proper selection of heads and locks, and, further, that when the installation is made, the discipline be such that the hose are properly maintained and that they are hung up when not in use.

There are three general methods of charging the auxiliary storage batteries used with steam driven head end systems. One is to charge en route, another is to charge while cars are lying over at terminals, and the third is a combination of the two. Two methods of charging en route are used; one to charge during the period of lightest lamp load; the other to charge during the daylight hours when the lighting is ordinarily cut off. Charging en route when the lighting load is a minimum is self-evidently the best and most economical method, due to the material saving in steam, higher efficiency of the generating plant and less liability of burning out fans which may be required, and lamps burning in dark portions of the train during the charging period. Charging en route during the lighting hours necessitates some provision to reduce the voltage at the lamps, eighty volts nominal being carried on the car mains connected to the dynamo terminals for charging.

#### HEAD END AXLE SYSTEM.

The Northern Pacific has been experimenting for a number of years with various types of large capacity axle driven generators for lighting an entire train. In March, 1909, a test was made of an axle-driven, 20-kw., 80-volt generator installed in a special dynamo car. This machine was mounted on a steel sub-base bolted to the car truck and arching the center sills. The drive was by means of two leather belts running over idler shafts between the car axle pulleys and the generator pulleys. The wiring arrangement was for constant voltage. Control of the voltage and current was by means of Bliss automatic regulator. One large set of storage batteries on the dynamo car only was used for the entire train.

This equipment was run for several trips on one of the short runs with very good electrical results. Owing to operating and other conditions existing at that time the use of this type of equipment was temporarily discontinued. In the fall of 1912 three trains running between St. Paul and Winnipeg were each equipped with a 4-kw., 50-ampere, 80-volt "Safety" axle-driven generator outfit. The machines are belt driven and are mounted on the car trucks with standard link suspensions.

Each train consists of a parlor car, dining car, two coaches and a mail and express car, the four passenger cars only being lighted by electricity. The generator is located under the dining car. The parlor car and both coaches are equipped with nine plate, 200 ampere hour storage batteries. All cars are equipped with lamp regulators and are connected to each other in the usual manner by standard train connectors. The total lamp and fan load is 50.5 amperes.

The operation of this equipment has been entirely successful with the exception of the usual amount of belt trouble

experienced during winter months. A 5-in., five-ply, balata belt was originally used, but was found to be too narrow and all equipments have since been equipped with 6-in., four-ply belts, which are giving much better results.

In the spring of the present year seven Gould Simplex 4-kw., 50-ampere, 80-volt equipments were installed on as many trains running between Seattle and Moclips, Wash., and between Centralia and South Bend, Wash. The cars in each of these trains which are lighted by electricity, are a parlor or cafe observation car, a day coach, and a smoker. The equipment on the various cars is as follows: Lamp regulators and battery boxes wired complete under all cars; batteries under observation car and day coaches only; axle generator under observation car. Batteries are of the nine plate, 200 ampere hour type. The total lamp load is 37 amperes. Generator cuts in at a speed of approximately 12 m. p. h. All lamp regulators are set for 60 volts. Maximum variation from this voltage while running is approximately two and one-half per cent. The potential coil in the machine regulator is set for a maximum generator voltage of 80 volts. Current coil in generator regulator is set for a constant current of 50 amperes.

The operation of this equipment has also proven extremely satisfactory under adverse conditions. The trains running between South Bend and Centralia make twenty-five stops in 57 miles and run very slow over five miles of heavy upgrade. Each round trip comprises a daylight and a night run.

In general, the system of lighting several cars from one generator is a success. It has been said that the batteries would soon deteriorate due to charging in parallel. This is the usual method, however, used in regular head end systems and also at terminals and it has been the experience thus far on the Northern Pacific that this method of charging leads to no unfavorable conditions. The main trouble experienced has been with belt slippage and in educating train men to keep train connectors up, particularly when extra cars are put in the train. The belt trouble has practically been eliminated by the use of wide belts. The education of trainmen is simply a matter of time.

The one principal objection to the system, that is, that all cars lighted must be equipped with lamp regulators, can be overcome by the use of a single large capacity lamp regulator located in the generator car. With this method any car wired for electric lights may be used in the train. A lamp regulator of this type will be used in connection with a 20-kw., 80-volt axle equipment, which is nearly ready for delivery. This machine will be located inside the baggage car and mounted directly on the truck in the same manner as the one previously referred to, except that the drive will be by means of Morse silent chains. Instead of being a constant current machine as the smaller capacity equipments are, it will be constant potential and will be protected by an overload circuit breaker located in the dynamo mains.

#### LOCOMOTIVE HEADLIGHTS.

Wherever it is possible and practicable, the generating unit should be installed on top of the boiler as near the cab as convenient and the exhaust pipe projected slightly above the cab and bent backward. The steam pipe should be tapped into the turret, when possible, and provided with a suitable valve located inside the cab. A suitable strainer should be provided in the steam line and located as near the machine as possible and still be readily and easily accessible for cleaning.

Where high power headlamps are used, particular attention is called to the necessity of having the reflector properly set in the case and the case mounted on the locomotive so that the ray of light will be projected down the center of the track and parallel with it. In no case should it be necessary to move the light out of its true focus in order to project it parallel with a straight track, for, by so doing, the

light rays are more or less concentrated in a spot on the glass and may cause it to break.

In all cases, with high power lights used with parabolic reflectors, it is deemed advisable to use what is known as the "oval" or "heat resisting" glass in preference to the plain flat glass, either in one piece or in strips.

Special attention is called to the fact that many of the states laws require that the headlamp shall have not less than 1,500 candle power, when measured without reflector. Others specify 10,000 candle power measured with reflector; others require 300 watts at the arc, while some require that an object the size of a man shall be distinctly seen at certain specified distances, one state requiring a specific dimension of reflector.

The committee in considering the summary of these laws are of the opinion that they were drawn without due consideration of a suitable standard condition or basis under which test could be made and reproduced, and would recommend that this association express its sentiment as being unfavorable to the enactment of any law or laws which do not clearly specify a standard national basis under which test may be made.

And, whereas, some of the laws, as enacted, tend to preclude the use of more efficient apparatus, and the methods of using the same, which tend to retard the art of invention and application, the committee recommends that it be the sentiment of this organization that if such laws are enacted, that standard specifications, as outlined above, be so drawn as not to eliminate apparatus which may be invented or designed in the future. It is the opinion of this committee that the quantity and quality of illumination at some specific point is the prime object and not the means or apparatus by which this illumination may be effected or obtained.

#### DYNAMO SUSPENSIONS.

The committee reporting on this subject believes that on all dynamo suspensions the metal carrying the weight of the dynamo should not be subjected to wear, and where a link type of suspension is used the form presented at the recent Master Car Builders' Association and illustrated in the *Daily Railway Age Gazette* of June 18, page 1483, was recommended. Attention was called to the suspension used by the Pennsylvania Railroad, which is built out from the end of the truck and is considered strong and safe. A steel truck manufacturer has just brought out a cast steel rigid suspension which is being applied to some cars on one of the eastern railroads. This suspension has a base on which any type of common standard generator may be mounted. The manufacturer has also brought out a bracket which is riveted to the side of the truck, taking the place of the side iron and brace, and to which the links of any of the standard makes of suspension may be fitted. One railroad is now experimenting by attaching the generator securely to the fish belly girder and driving the generator by a  $\frac{3}{4}$  in. flexible belt made of No. 12 steel wire formed by winding the wire on a rod spirally with the turns touching each other in normal position. A 21 in. V-shaped deep grooved pulley is used on the axle, and an 11 in. deep grooved pulley on the generator. The flexible wire belt will stretch and allow for side movement of the trucks, etc.

#### OTHER BUSINESS.

The report of the secretary-treasurer showed a membership of 500 and a balance in the treasury of \$1,146.

The Electric Storage Battery Company gave a banquet to the members on Tuesday evening, at which time its new axle generator lighting system of the constant voltage type was described and discussed.

RAILWAYS OF SOUTH AFRICA.—In the Union of South Africa there were on December 31, 1911, 7,548 miles of railway owned and operated by the government, and 545 miles privately owned.



## JONES' MAIL CATCHER.

The mail crane shown in the accompanying engravings is one devised by William H. Jones, of Manhattan Beach, Cal., and it is being tried on the Coast Line of the Southern Pacific, cranes having been put up at the first twenty stations north of Los Angeles. The performance of the catching apparatus is being recorded by the post office department with a view to



Fig. 1—Jones' Mail Catcher, Ready for Use; As Seen from Railroad Track. Fig. 2—Jones' Mail Catcher; Horns Held Away from Track by Counterweight.

making up a record, at the end of six months' service, for purposes of comparison with other devices.

The pair of horns, having the appearance of a circle, at the top of the standard are supported in a cradle which is so pivoted that when the crane takes a bag from a passing train the "horns" are turned upward and outward so as to remain



Fig. 3—A Bag That Has Been Taken from a Train. Fig. 4—Bag Waiting for Train.

in a position farther away from the track than when in use. The column is fixed to a concrete foundation. In the views Fig. 1 and Fig. 2, the observer is supposed to be standing on the track. The step-ladder, shown raised in the picture, rests, when it is down, about two feet from the rail of the track. The ends of the horns, one of which points east and the other west, overlap each other about 4 feet; and at a point about 4 feet from

the tip end of each there is a joint by which the horn may be swung away from the track when not to be used.

Inside of the mail car there is a track running across the car immediately under the roof and opposite the doors at the sides of the car. Hanging from this track is a steel carriage on wheels, and from this a delivery arm extends out at either end. When this carriage is attached to a hook on the forward side of the door of the car, and the delivery arm is pushed out, the hook or receiving arm of the steel carriage is automatically put into position to take on a mail bag.

In operation the station man fastens his mail bag to a ring of suitable design (see Fig. 4), and this ring he slides into a slot at the end of the delivery arm on the standard. In Fig. 1 this arm appears within the circle formed by the horns. When the agent thus prepares for an approaching train, the horns and the circular rod supporting them are in a horizontal position. The finger of the horn which is not to be used is folded back, and the other is left pointed toward the coming train.

When the train is approaching a station, the mail clerk on the car takes the bag to be left and attaches it to another of the special rings and puts this ring on one of the delivery arms in the car. He pushes this delivery arm along the overhead track and out of the door. The act of pushing this arm into position automatically latches it to the door and retains in proper position the delivery arm, with the bag suspended for the exchange. The catcher hook will have been set in position by the same motion that sets the delivery arm.

As the exchange is taking place the point of the catcher hook on the car passes through the ring which is fastened to the bag on the delivery arm of the roadside standard, dragging the bag from the standard and whirling it into the car, where it is deposited on the floor. At the same moment the receiving horn on the crane passes through the ring that was hanging from the delivery arm on the car, the ring with the bag attached, and the horn, swing around, stopping when the bag reaches the standard.

The weight and momentum of the bag causes the horns to assume a position of about 45 degrees upward (Fig. 2), so that they clear the track by a safe margin.

This device has been tested with trains running at all speeds up to sixty miles an hour. In one of the experiments some small crates of eggs were put into the mail bag and are said to have been transferred, without damage, while the train was running at 55 miles an hour. Transfers have been made of bags weighing as much as 450 lbs. This mail crane is made by the Universal Mail Dispatcher Company, Los Angeles, Cal.

RAILWAY CONSTRUCTION IN SWITZERLAND.—A number of lines are in course of construction in Switzerland, which will add important branches to the government railway system and materially increase the transportation facilities of the country. The most important of these local lines is the one starting from Brigue, which joins the valley of the Rhone to the valley of the Rhine, passing by the Furka and the Overalp, crosses the Gothard, and joins the terminus of the Rhenian railways at Disentis, opening up a region hitherto inaccessible by rail. From Andermatt, which is some thousand feet above the Gothard tunnel, a rack railway will descend to join the Gothard line at Goeschenen. A new line is being built from Loeches in the Rhone valley to Loeches-los-Bains, at the foot of the Membré, and one from Coire to Arosa, in the Engadine. There are also new lines from Steffisburg-Thun to Interlaken, running along the northern shore of the lake of Thun and from Interlaken to Brienz, which will facilitate the journey from Interlaken to Lucerne via Brienz; and still another line from Locarno, on the Lake of Maggiore on the Simplon, by the valley of the Vigessa, to Domodossola, linking up the latter route with the Gothard. In addition to these, there are a number of short lines under construction leading into districts heretofore inaccessible by rail, and in which is to be found some of the most romantic and attractive scenery in Switzerland.

ACCIDENT BULLETIN NO. 47.

The Interstate Commerce Commission has issued quarterly Accident Bulletin No. 47, containing the record of railway accidents in the United States during the three months ended March 31, 1913. The number of persons killed in train accidents was 158, and injured, 3,628.

The total number of casualties of all classes reported, including industrial accidents, amounted to 2,341 killed and 47,634 injured. "Industrial accidents," are those occurring to employees where the movement of cars or engines is not involved. The accidents are summarized as follows:

TABLE NO. 1.—CASUALTIES TO PERSONS—STEAM RAILWAYS.

Causes.	Passengers.		Employees (including employees not on duty).		Other persons (trespassers and non-trespassers).		Total persons.	
	Killed	Inj'd	Killed	Inj'd	Killed	Inj'd	Killed	Inj'd
<b>Train accidents.</b>								
Collisions .....	12	1,030	59	895	2	26	73	1,951
Derailments .....	3	825	61	541	6	21	70	1,387
Miscellaneous train accidents, including locomotive-boiler explosions .....	...	14	13	273	2	3	15	290
<b>Total .....</b>	<b>15</b>	<b>1,869</b>	<b>133</b>	<b>1,709</b>	<b>10</b>	<b>50</b>	<b>158</b>	<b>3,628</b>
<b>Other than train accidents.</b>								
Accidents to roadway or bridges not causing derailment (515) .....	...	...	5	15	1	1	6	16
Other accidents (classes C-3 to C-12, inclusive) .....	53	1,680	669	13,044	1,358	2,454	2,080	17,178
<b>Total .....</b>	<b>68</b>	<b>3,549</b>	<b>807</b>	<b>14,768</b>	<b>1,369</b>	<b>2,505</b>	<b>2,244</b>	<b>20,822</b>
<b>Industrial accidents to employees.</b>								
While working on tracks or bridges .....	...	...	41	5,225	...	...	41	5,225
At stations, freight houses, engine houses, etc. ....	...	...	18	6,522	...	...	18	6,522
In and around shops .....	...	...	16	13,276	...	...	16	13,276
On boats and wharves. ....	...	...	7	404	...	...	7	404
At other places .....	...	...	15	1,385	...	...	15	1,385
<b>Total .....</b>	<b>...</b>	<b>...</b>	<b>97</b>	<b>26,812</b>	<b>...</b>	<b>...</b>	<b>97</b>	<b>26,812</b>
<b>Grand total ....</b>	<b>68</b>	<b>3,549</b>	<b>904</b>	<b>41,580</b>	<b>1,369</b>	<b>2,505</b>	<b>2,341</b>	<b>47,634</b>

Table No. 1A, following, presents comparisons of the principal items of the current bulletin, as well as in the like table of the bulletin next preceding and of the bulletin covering the corresponding quarter of the previous year.

TABLE NO. 1A.—COMPARISONS.

No.	Item.	Bulletin No. 47	Bulletin No. 46	Bulletin No. 43
1	Passengers killed in train accidents.....	15	57	33
2	Passengers killed, all causes.....	68	114	71
3	Employees (on duty) killed in train accidents.....	132	170	209
4	Employees (on duty) killed in coupling.....	62	54	49
5	Employees (on duty) killed, total.....	734	861	884
6	Total passengers and employees (items 2 and 5, above) .....	802	975	955
7	Other persons killed (including trespassers, non-trespassers, and employees not on duty), all causes .....	1,442	1,886	1,428
8	Employees killed in industrial accidents.....	97	106	98
<b>Grand total (items 6, 7, and 8).....</b>		<b>2,341</b>	<b>2,967</b>	<b>2,481</b>

The total number of collisions and derailments in the quarter under review was 3,982 (1,679 collisions and 2,303 derailments), of which 217 collisions and 163 derailments affected passenger trains. These are classified as follows:

TABLE NO. 2.—COLLISIONS AND DERAILMENTS.

No.	Classes	Number	Killed	Inj'd	Damage to road and equipment
1	Rear .....	344	32	650	\$363,689
2	Butting .....	187	10	513	239,969
3	Trains separating .....	90	...	29	35,620
4	Miscellaneous .....	1,058	31	759	525,102
<b>Total .....</b>		<b>1,679</b>	<b>73</b>	<b>1,951</b>	<b>\$1,164,380</b>

No.	Classes	Number	Killed	Inj'd	Damage to road and equipment
<b>Derailments due to—</b>					
5	Defects of roadway.....	529	17	511	\$382,989
6	Defects of equipment.....	1,104	8	306	790,341
7	Negligence .....	116	1	94	64,152
8	Unforeseen obstruction .....	126	30	212	252,537
9	Malicious obstruction .....	10	2	8	18,314
10	Miscellaneous causes .....	418	12	256	346,696
<b>Total .....</b>		<b>2,303</b>	<b>70</b>	<b>1,387</b>	<b>\$1,855,029</b>
<b>Total collisions and derailments..</b>		<b>3,982</b>	<b>143</b>	<b>3,338</b>	<b>\$3,019,409</b>
<b>Total for same quarter of—</b>					
1912 .....		3,903	217	4,251	\$3,368,125
1911 .....		2,801	128	2,806	2,124,090
1910 .....		3,163	244	3,215	2,607,553
1909 .....		2,284	163	2,315	1,847,202

The usual tables are given classifying certain accidents in detail. Table 1B is an amplification of Table 1. Table 3 divides into 28 sub-classes the causes of accidents to employees in coupling and uncoupling cars. Table 3A classifies these same accidents according to the nature of the injuries. Table 4 divides into eighteen sub-classes the causes of accidents to employees due to falling from cars and getting on or off cars.

Table 2A divides into eight sub-classes derailments due to defects of roadway; table 2b divides into thirteen sub-classes those due to defects of equipment. Table 1b gives a surgeon's classification of the injuries to passengers, employees and others, which are summarized in table No. 1.

Tables 4A, 5A and 8A sub-divide the causes of miscellaneous accidents on or around trains; of cases where trainmen strike overhead bridges, etc., and of miscellaneous accidents on or around trains to passengers and to employees not engaged in work connected with the operation of the train.

Thirteen accidents occurring during this quarter were investigated by the inspectors of the commission and the reports of these investigations fill 25 pages of the bulletin. The accidents occurred as follows:

- Wabash ..... Detroit, Mich. .... Jan. 2, Derailment
- Vandalia ..... Terre Haute, Ind. .... Jan. 8, Rear collision
- Grand Trunk ..... New Haven, Mich. .... Jan. 16, Butting collision
- Canadian Pacific ..... Onawa, Me. .... Jan. 21, Rear collision
- International (Electric)..... Lockport, N. Y. .... Jan. 25, Rear collision
- Houston & Tex. Cent. .... Benchley, Tex. .... Feb. 1, Derailment
- Union Pacific ..... Valmont, Colo. .... Feb. 11, Butting collision
- Southern ..... Jennings, Va. .... Feb. 25, Butting collision
- Chicago & No. West. .... Goose Lake, Ia. .... Feb. 28, Butting collision
- Minneapolis & St. L. .... Steamboat Rock, Ia. .... Mar. 4, Butting collision
- Pere Marquette ..... Okemos, Mich. .... Mar. 10, Derailment
- Union Pacific ..... Gothenburg, Neb. .... Mar. 14, Rear collision
- Union Pacific ..... Herdon, Neb. .... Mar. 14, Rear collision

Electric railways reporting to the commission (not included in the foregoing statistics) had 72 persons killed during the quarter and 1,281 injured; and there were 51 collisions and 14 derailments. Train accidents are charged with 5 fatalities. The total number of passengers killed from all causes was 4, and of employees 15 (6 in industrial accidents). The number of trespassers struck or run over by cars was 37; 19 killed and 18 injured.

RAILWAY CONSTRUCTION IN THE BELGIAN CONGO.—The plans for building the third section of the Kambove-Bukama Railway, Belgian Congo, are finished. Permanent way work has been started at Kambove, and a second gang of track layers will shortly commence operations from the Bukama end. The proposed line from the Lower Congo to Katanga would have involved the construction of a line 271 miles long between Bukama and Lukengo on the Sankuru. It is suggested, however, that this line would have little practical value, so that a further proposal has been made to carry on surveying operations for the construction of a line south of the Kasai-Sankuru Railway. This line, which would have a length of 1,180 miles, would leave the Congo Railway at Dolo, cross the Kwango river and the Kasai river, and would then pass close to Luebo and Luluabourg, crossing the Sankuru river and terminating at Bukama, and will develop the territory to the south of the Congo.

## RAILWAY SIGNAL ASSOCIATION.

This association held its 18th annual meeting at Nashville, Tenn., October 14, 15 and 16, with an attendance, including ladies and guests, of over 400, one of the largest meetings ever held by the association.

The president of the association, B. H. Mann, signal engineer of the Missouri Pacific, in his opening address showed that an unusually large amount of good work had been done by the committees of the association during the past year. He emphasized the need of uniformity everywhere in signaling standards and practice and, calling attention to the fact that there are still many roads which do not use the association standards and apparently do not fully realize the importance of adhering to them, he urged each member to constitute himself a missionary or salesman to recommend and promote the use of the association standards on the roads of his neighbors. If any member doubts his ability to fill the role of salesman or promoter, let him take lessons from the associate members; they know the art.

The secretary's report showed the membership of the association to be 1,209, a small increase over the number on the rolls one year ago.

The report of the board of direction recommended that chairmen of committees, to promote systematic work, try to have regular meetings on at least one day in each month. It is desirable that statistics be gathered to show the extent to which the standards of the association are used. The price of the manual has been increased to \$5, the book being now much larger than when first issued. The representative membership in the association has been increased during the past year about 50 per cent., an improvement which is credited largely to the energetic work of the president.

The first report presented to the meeting was that of committee No. 1, T. S. Stevens (A. T. & S. F.), chairman. This committee has gathered information from many roads concerning the effect of treated and metal ties on track circuits. The committee finds that track circuits a mile long or longer are frequently rendered inoperative by the extensive use of zinc treated ties; but that circuits 2,000 ft. long may be operated successfully, even with half the ties treated; that 10 to 15 per cent. of renewals each year will not materially affect circuits of such length; that the effect is worse where ties are laid in bunches than where they are laid one in a place, that is to say, every sixth or seventh tie; that during rains salts on the surface of a tie make the leakage worse than with ordinary wet wood; that in dry, hot weather the salts are drawn to the surface and constitute a good conductor; and that the salts disappear in from three to twelve months and thereafter there is no trouble.

In the discussion many members gave their experience both with zinc treated and creosoted ties. Emphasis was laid on the importance of studying ties with care from all standpoints; troubles have many times been laid to the zinc or the creosote when they were really due to something else. There was testimony to the effect that creosoted ties had improved the action of a track circuit. Mr. Christofferson (N. P.) had found that in wet weather creosoted ties improved the operation of the track circuits. Mr. Latimer (C. B. & Q.) has no trouble with track circuits, where the ties were treated with the zinc process and creosote combined; but most of his circuits are only 2,500 ft. long. The creosote forces the zinc into the tie and covers it up. Crude oil has also been used for this purpose—forcing the zinc into the tie—and it is cheaper than creosote. Mr. Beaumont (C. G. W.), had found that the operation of the track circuit was interfered with at an icing station and for five miles away from it, by the drippings of brine from refrigerator cars. Signal engineers ought to advocate the provision of tanks under refrigerators to collect the brine. In the discussion of track circuit troubles from other causes it was shown that in one case a track circuit 2,700 ft. long, which would not work, was made all right by the substitution of new bond wires; the old ones were of poor

quality. Certain track circuits were found to be broken down by the presence of the "anti-creepers," put in to keep the track from creeping.

Dr. Von Schrenk said that often zinc treated ties are used too soon; these, as also creosoted ties, should be three or four months old before being put into the track.

That part of the report of committee No. 1 which dealt with switch indicators was postponed until the last day.

Committee No. 2, C. J. Kelloway (A. C. L.), chairman, presented a report consisting mainly of six drawings of switch layouts which were recommended for adoption. As the committee presented no discussion on the drawings it was proposed that the report should be referred to the committee on standards. This would entail at least a year's delay and it was urged that standards are needed now, especially for use at joint interlockings. No action was taken, however, and the drawings were accepted as information.

Committee No. 3, R. C. Johnson, chairman, on power interlocking, submitted a number of specifications of details, additions to specifications heretofore adopted, and a recommendation to rescind action taken in 1911 on 20 typical circuit plans which were then approved by letter ballot. This recommendation was adopted, the 20 plans to be classed henceforth as information only.

Specifications for annunciator bells reported by this committee were objected to as being an unnecessary addition to the manual, the subject being of too little importance for such treatment; nevertheless, the specifications were adopted, and sent to letter ballot. The specifications for push buttons, offered by the committee, were accepted, after some modification, and ordered sent to letter ballot, and the same was done with specifications for floor pushes.

Specifications for fuses, pages 317-320, after slight alterations, were accepted and sent to letter ballot.

A sub-committee of committee 3, F. B. Wiegand, chairman, presented nine typical circuit plans for electric interlocking, which were accepted as information. Another sub-committee, I. S. Raymer, chairman, presented specifications for steel pipe conduit which were accepted and ordered referred to letter ballot. The same action was taken on a code of specifications for wrought iron pipe conduit.

Specifications for the installation of a vitrified clay conduit system, presented by this committee, were subjected to considerable discussion and were finally accepted only as a progress report. The changes proposed by the committee in the specifications adopted last year for the manufacture of vitrified clay conduit, shown on pages 309 and 310 of the program, were adopted by the association, and sent to letter ballot.

### AUTOMATIC BLOCK SIGNAL DETAILS.

Committee No. 4, A. G. Shaver (C. R. I. & P.), chairman, reported on apparatus and materials for use in automatic block signal construction, and presented some typical circuit plans for automatic block signaling. Specifications for zincs and coppers for gravity battery were adopted and referred to letter ballot; but with the proviso that the drawings should show both two-leaf and three-leaf coppers. The Rock Island road expects to abandon the use of gravity batteries. Drawing No. 1189 for a gravity cell jar was adopted and sent to letter ballot. A sub-committee, E. L. Adams, chairman, submitted information gathered in its investigation of relays. This sub-committee has found no suitable method for testing the magnetic quality of the iron used in magnet circuits. As to sweating of relays, nothing definite has been determined but it has been shown that ventilated relays sweat less than those not ventilated; that relays in wooden boxes or in iron boxes with wooden lining, having an air space between the iron and the wood, sweat less than relays in plain iron boxes, and that openings from relay boxes to ground should be sealed. Mr. Denney (L. S. & M. S.) called attention to the necessity of testing relays after they have been in service for a time. The drop-away limit varies with varia-

tions in the strength of the spring and also with the quality of the iron in the coils. Mr. Beaumont (C. G. W.) had found that the fingers of relays sometimes caused failures because they did not remain in true contact. Fingers should be cut always along the grain of the metal.

Information as to the adjustment of the maximum allowable working current, the maximum allowable pick-up, the minimum allowable drop-away with contact pressure, and minimum allowable drop-away without contact pressure, was presented by the committee in the shape of graphic diagrams, one showing calculations for relays up to 100 ohms, and the other from 100 ohms to 1,300 ohms. Several members preferred that this information should be given in tables of figures, rather than graphically; and the committee was directed to prepare tables.

The typical circuit plans presented by this committee for block signaling, double track and single track, were criticized in various particulars and finally were referred back to the committee.

#### MANUAL BLOCK SIGNALING; ESTIMATES OF COSTS.

Committee No. 5, Thomas S. Stevens (A. T. & S. F.), chairman, presented 20 diagrams showing different arrangements of manual and controlled manual block signals, with estimates of the cost of the different arrangements. The simplest one shown was that of a block signal at a station with both arms on the same post; while the most elaborate showed lap sidings with starting, home and distant signals, and with derails. The cost of the simplest installation is \$150 and of the most elaborate \$6,490.

This committee proposed that the association recommend certain changes in the American Railway Association rules for signalmen, the principal proposal being that rule 629 be shown in alternative forms, one form to prohibit absolutely the use of hand signals as authority to pass fixed signals at interlockings which are in the stop position because of some trouble with the apparatus or connections. There was strong objection to this proposal. No road is likely to decide to tie itself up absolutely to either one rule or the other; either to the exclusive use of cards or to the exclusive use of hand signals. After a long discussion rule 629 was referred back to the committee, together with those other parts of the report which are affected by this action. Rules for signal foremen and maintainers, presented by the committee, were accepted and sent to letter ballot for inclusion in the manual. The meeting adopted a resolution recommending to the American Railway Association that rule 667 be amplified so as to prevent any possible interference with interlocking switches by careless action on locomotives.

The report of committee No. 7, E. G. Stradling, chairman, consisted of about 50 definitions which the committee proposes for a new signal dictionary. These definitions were accepted without discussion and sent to letter ballot.

Committee No. 6, J. C. Mock, chairman, reported on standard designs. The committee finds a very general and increasing demand among the railroads for Railway Signal Association standard designs. The committee recommended revisions in a number of standards now in use, including bracket posts. It will be necessary to redraw all standards adopted prior to 1912, so as to make them uniform in regard to size of sheet and arrangement of reference numbers. The meeting adopted and referred to letter ballot drawings presented by the committee as follows: page 503, drawing 1039A; page 504, drawing 1058; page 505, drawing 1063; drawings 1084 and 1085; drawings 1095, 1099, 1103, 1105, 1108. Drawing 1223, showing details of switch box connections, was adopted after the chairman had explained certain corrections to be made in details. The details of switch box connections were subjected to considerable criticism but finally were adopted, including drawings 1225, 1226, 1239; also 1350, 1351 and 1352, chain wheels.

The association approved certain recommended variations to be allowed from nominal dimensions in signal fittings.

#### CURRENT HISTORY.

Committee No. 8, H. S. Balliet (N. Y. C.), chairman, presented a report filling about 90 pages, made up mostly of descriptive accounts of installations of alternating current signaling now in use on 15 prominent roads. This matter is supplementary to other descriptions heretofore printed by the association. The meeting approved matter, submitted by the committee, to be added to the specifications for alternating current automatic block signals. Extensive additions to the specifications for alternating current apparatus were also approved.

Committee No. 9, W. H. Elliott (N. Y. C.), chairman, recommended changes in the specifications for rubber compound for insulated signal wires and cables; for galvanized steel wire for connections to mechanically operated signals and for enameled copper magnet wire. All this matter was accepted and ordered to letter ballot. It was explained that the specifications for enameled copper magnet wire had been copied from those of a prominent manufacturer, information on this subject being not easy to get. At the suggestion of Mr. Corey (Union S. & S. Co.) the association added to the specifications (clause 10) a stipulation that spools for enameled magnet wire shall be not less than  $1\frac{1}{2}$  in. in diameter.

Committee No. 10 submitted for reference to letter ballot, specifications for stationary storage batteries of pure lead type, with seven drawings. The action of the committee was approved except that the drawings showing the arrangement of the lead elements (page 486) were found unsatisfactory in certain details.

The special committee on methods of recording signal performance, W. N. Manuel, chairman, was instructed to revise the forms which were approved in 1912, and the committee will report at the meeting next March.

A special committee, consisting of C. C. Anthony (Pennsylvania), and J. M. Waldron (Interborough R. T. Co., New York), having been directed to confer with a committee of the Railway Telegraph Superintendents' Association on specifications for wire crossings, presented a set of specifications for crossings of low tension wires over steam railroad rights of way, etc. These were criticized as containing features not exactly like those of the association's code for the construction of telegraph lines; but after an explanation to the effect that these have been adopted by the committee mainly for the purpose of securing uniformity with the work of the telegraph superintendents, and that in work of this kind usually the telegraph superintendents have the major interest, the specifications were adopted, a typographical error in clause 14 being first corrected.

#### SWITCH INDICATORS.

With the conclusion of the foregoing discussion the association reached the end of its program; but, in accordance with a desire expressed on Tuesday, the report of committee No. 1 was again taken up and the use of switch indicators at outlying switches in automatic block signal territory was discussed at considerable length. The committee had reported a code of requisites for use when a railroad has decided that switch indicators are to be used; but the meeting insisted on discussing the prior question whether or not the use of indicators is desirable. The differences between those who believed indicators important and useful and those who held them undesirable, were very decided. The committee's recommendation that indicators are not necessary at facing points of passing sidings was criticized, and Mr. Stevens (A. T. & S. F.) declared that he should go on installing indicators at such switches. The New York Central is not putting in indicators and is taking out indicators heretofore installed. The flagging rule is required to be observed. Mr. Dunham (G. N.) and Mr. Kelloway (A. C. L.) agreed with Mr. Elliott; if there is a flagging rule, enforce it; if indicators are to be used abolish the flagging rule; if the indicator shows clear, trainmen will neglect to flag, and the expense of the indicator is not warranted; it simply encourages neglect of the flagging rule. Mr. Kelloway said that

when he was on the Delaware, Lackawanna & Western, the indicators on a certain division were taken out and the train service was thereafter improved.

Mr. Mock (M. C.) argued in favor of the use of indicators. Experience with them on his road has been satisfactory. Flagging is a much less reliable method of protection than is a signal.

Mr. Fugina (L. & N.) favored the use of indicators. He had reached this opinion as a result of experience, having originally held the opposite view. The operating officers of his road favor the indicator as a means of checking the obedience of trainmen and of discovering, in case of dispute, which one of two trains was at fault.

Mr. Rose (C. C. C. & St. L.) stood up for the flagging rule, and declared that if the indicator were to be used generally it ought to be made more important and treated exactly like a signal.

The view of the committee, that a switch indicator should be used to indicate only the approach of trains, was criticized as unnecessary. There is no harm in having an indicator which shows red after a train has passed it.

#### THE COMING YEAR.

The meeting voted that the next annual meeting should be held at Hotel Champlain, Bluff Point, New York, a short distance from Plattsburgh. The date selected by the committee, September 22, was approved; but final approval can come only by letter ballot, the committee having no power to fix a date in September. At Bluff Point the hotel can be engaged immediately after the close of the regular summer season, so that the association will have the exclusive use of the whole establishment. Another reason for meeting in September is to avoid a conflict with the date of the meeting of the Street Railway Associations.

The result of the letter ballot for officers of the association for the ensuing year is as follows: president, F. P. Patenall, Baltimore & Ohio, Baltimore, Md.; second vice-president, W. J. Eck, Southern Railway, Washington, D. C. T. S. Stevens, A. T. & S. F., automatically becomes first vice-president. Secretary C. C. Rosenberg, Bethlehem, Pa., was, of course, re-elected.

#### A WORD FROM E. J. PEARSON.

The annual dinner of the association, held on Wednesday evening, went off with the usual success of these popular affairs. One of the principal speakers was to have been Mr. E. J. Pearson, first vice-president of the Missouri Pacific and in charge of the operating department of that road; but he was unable to be present and sent a communication by telegraph, which was read by J. L. Lancaster, president of the Union Railway of Memphis. Mr. Pearson, unlike most operating officers, has had experience in signal engineering, having formerly been in charge of that department on the Chicago & Northern Pacific. He gave interesting incidents of past events in the signaling field, telling of the sensation created in the early nineties by roads which made such bold moves as the installation of extensive and costly power interlockings like some of those at Chicago, St. Louis and elsewhere, and of automatic block signals on Missouri river bridge gantlets, effecting great economies which most railroad officers had thought impossible. Mr. Pearson gave the signal engineers credit for having met and rightly and fully solved the important problems that have confronted them. Many of these problems have changed their aspect almost constantly and the signal engineer has had to be constantly on the alert to revise his standards and requirements.

He paid a warm and discriminating tribute to B. H. Mann, president of the association, as an officer of the Missouri Pacific whose talents are an important asset of the operating department, as well as in signaling. This association should follow the Master Car Builders' Association in recommending to the American Railway Association its well settled standards; and in such busi-

ness-like and thorough treatment of matters of this kind as to merit the prompt recognition of the older association.

The signal engineer has not only his technical duties, but a general duty to promote economical operation, and to make his road efficient and popular. The problem of the introduction of steel passenger cars, as a measure of safety, is outside his immediate field; but he must consider it, nevertheless; for that problem is affected by what is done with his problem of preventing collisions.

The "universal aspect," which was the title of Mr. Pearson's remarks, he defined as the all-pervasive question of finances. Every engineering and operating question must square with the question which is before the board of directors; can we get the money? This question is just now so difficult that railways as a whole are not keeping pace with the progress of the country. The public, however, is at heart fair and liberal; let us see that the people correctly understand our problems and our needs.

## THE ABATEMENT OF LOCOMOTIVE SMOKE.\*

By D. F. CRAWFORD,

General Superintendent of Motive Power, Pennsylvania Lines  
West of Pittsburgh

Of the smoke produced in any locality where bituminous or soft coal is generally used for manufacturing, power and domestic purposes, I think it will be found that locomotives contribute but from 15 to 20 per cent., with perhaps a somewhat higher proportion in localities where comparatively few industries are located, and, of course, a considerably greater proportion where fuel other than bituminous coal is used for domestic purposes. The emission of smoke in the large quantities inherent to the use of large locomotives has permitted the railways in America to produce transportation of passengers and freight at the lowest cost of any country in the world, as to obtain this result large units and consequently large coal consumption is necessary.

The above presents the problem which confronts the railway officer in considering this subject. To obtain from the modern locomotives the average power required from them it is necessary to consume fuel at the rate of about 100 lbs. of coal per square foot of grate per hour, and to obtain the maximum power required it is necessary to consume 150 lbs., and at times in excess of this amount, per square foot of grate per hour. That is, to obtain the power necessary to perform the work demanded, a boiler which from its heating surface would be rated at about 320 horsepower is frequently forced to develop over 1,500 boiler horsepower, and our records show that another boiler, which would on the basis of heating surface be rated at about 400 horsepower, has developed as high as 1,994 boiler horsepower. This performance requires coal consumption at the rate of from 6,000 to 10,000 lbs. per hour, and in the cases cited this was done on a grate of 55 sq. ft.

It is evident that the abatement of the smoke from such combustion is beyond comparison with the simplicity of taking care of the smoke from a stationary boiler with the low rates of combustion obtained in such practice. Economical railway operation forbids the use of smaller units as well as underloading those in service. Therefore, the situation must be met without diminishing the efficiency of the railway as a transportation facility and with as little additional cost to the purchaser of transportation as may be possible.

Of the methods for the abatement of smoke from locomotives that are available, I have knowledge of the following:

- (1) The use of comparatively smokeless fuels.
- (2) The use of air jets.

\*Abstract of a paper prepared for the International Society for the Prevention of Smoke.

- (3) The use of mechanical stokers.
- (4) The instruction of the men operating the locomotives and supervision of their work.
- (5) Elimination of the steam locomotive.

Inasmuch as the kind of coal which will most likely be used is apparently settled by the geological distribution of the coal and the geographical location of the railways in relation thereto, it would seem necessary to devote our energies and time in an endeavor to meet the situation with the materials available.

THE USE OF AIR JETS.

To support combustion a certain quantity of air must be supplied for each pound of fuel burned. In an endeavor to provide an adequate air supply many experiments with air or steam jets have been made, resulting in a large number of designs covering the type of jets and suggested location and arrangement.

It was decided at a conference of railway officers to appoint a committee to make a scientific study of the scheme as well as carefully planned practical experiments. This committee, of which I had the honor of being chairman, was composed of representatives of seven railroads, and all of them had had long experience with the locomotive and with the use of air jets of various forms for the abatement of smoke, as well as a keen interest in the subject before them. Upon examination of the drawings showing the arrangement, location and dimensions of jets in use on a number of railways it was found that the variations in practice were so great that without more definite information no conclusion could be reached, and arrangements were made with the Pennsylvania Railroad for a thorough test on the locomotive testing plant at Altoona, Pa., of a locomotive provided with jets of several designs, locations and arrangements, approved by the committee.

The conclusions from the tests were as follows:

(a) The steam jet combustion tube has a decided value in reducing smoke under the widely varied conditions of these tests. The results of the tests indicated that when the locomotive is working so that the smoke readings would average from 25 to 30 per cent., by admission of 2,000 cu. ft. of air per minute above the fire the smoke reading would reduce to an average of about 6.5 per cent., the amount of smoke being reduced almost directly in proportion to the amount of air supplied and the practical limit being reached in this locomotive at about 2,500 cu. ft. of air per minute, this amount of air causing the locomotive to fail to make sufficient steam.

(b) The air injected by the tube was found to be the greatest factor in reducing smoke, although a small amount of steam seems essential in smoke reduction.

(c) When using steam jets injecting air into the firebox it was apparent that a greater reduction in smoke was accomplished by their use with improper firing as compared with careful firing.

(d) The firebox temperature was found to be higher when the brick arch was in service as compared with the plain firebox, although the data does not consistently show that a reduction in smoke follows increased firebox temperature.

(e) The brick arch showed a considerable reduction in smoke when running, while on standing tests the brick arch showed little, if any, benefit in the way of smoke reduction when the proper mixture of air and steam is supplied.

(f) The steam jet tubes give the best results in reducing smoke when located so that the injected air and steam meet the flame as high as possible above the fire bed.

(g) Air openings in the fire door are of slight assistance in smoke abatement.

(h) The best results were obtained when from 4 to 6 lbs. of air per pound of coal fired was injected by the steam tubes from a location in the back boiler head above the fire door.

The tests indicate that for locomotives in yard service and

switching service, for the majority of the time they are in use the introduction of sufficient air to reduce smoke will not seriously decrease their capacity and will tend to improve the economy of coal consumption.

One of the difficulties to be overcome in the use of the air jet is the noise produced by the jets when supplying sufficient air to be of value in reducing smoke, and several forms of mufflers, or silencers, are now being used experimentally.

Since the completion of these experiments in March of this year, about thirty locomotives on the Pennsylvania Lines, and many more on the other lines used in switching service and yard service, have been equipped with the air jets, the design being modified to meet the conditions of each type of locomotive. These locomotives are under observation to ascertain whether the results obtained in actual service, where the locomotives must of necessity be handled by a large number of men, will be as favorable as those obtained under test conditions.

THE MECHANICAL STOKER.

For the past nine years the Pennsylvania Lines West of Pittsburgh have been working to develop a mechanical stoker for locomotive use, and the results so far have been sufficiently satisfactory to warrant its application to a total of 300 locomotives, of which 215 are at work—66 in passenger, 130 in freight, and 19 in switching service.

While, of course, the desire to use the mechanical stoker was primarily brought about by the desire to increase the capacity and efficiency of the locomotive, the question of smoke reduction was given full consideration, as it was felt that less smoke meant less expense for fuel. This device has proved, up to the present time, to be the most promising yet installed for the reduction of smoke from a locomotive using bituminous coal; in fact, under favorable conditions the smoke is practically eliminated. Repeated comparisons of the smoke produced by locomotives with and without the stoker show that those equipped with the stoker may be operated with from one-tenth to one-third of the smoke made by similar locomotives in the same service without the stoker, the amount of the reduction depending on the class of service and continuity of the run. Not only is the average amount of smoke made reduced, but the number of times dense smoke is produced is diminished, the large volume of dense smoke apparent each time fuel is supplied to the fire by hand being eliminated when the stoker is used.

Two locomotives, one with and one without the stoker, were attached to a double train of freight cars, so that each locomotive was loaded to its capacity, and observations of the smoke made while pulling the train up a heavy grade. In this case the average smoke was as follows:

Stoker fired locomotive.....	8.0 per cent.
Hand fired locomotive.....	78.0 per cent.

That the stoker firing is more uniform than hand firing is proved by the smaller number of times dense smoke is emitted from locomotives equipped with the stoker.

The results obtained during nine years of experimentation and the measure of success obtained are due to the interest of the executive officers of the railway in the subject, and their encouragement and authority to incur the expense involved in the work, as well as the interest and hearty co-operation of my assistants and those engaged in supervising the details of construction and operation. It required much patience to meet the many difficulties encountered in the endeavor to adhere to the principles established (one of which was the reduction of smoke) when the work was commenced. Since the beginning of experiments to August 1, 1913, locomotives equipped with stokers have made 51,860 trips; of these, the stoker handled 95 per cent. or more of the coal used on 34,390 trips, 70 per cent. or over on 7,865 trips, and less than 70 per cent. on 9,425 trips, less than 70 per cent. being considered as unsatisfactory performance. While the apparatus is now sufficiently developed to warrant the trial of a large number, the problem of maintaining

and satisfactorily operating them, with various kinds of coal, and teaching many men how to handle them to the best advantage, is still before us.

#### OTHER DEVICES.

It would not be proper to present a paper on this subject without mentioning two other devices, now largely used on locomotives, which assist in reducing smoke—namely, the superheater and the brick arch.

The superheater, which is now applied to many locomotives, and which will be applied to many more in the future, does much toward the abatement of locomotive smoke, in that it permits the operation at a given power output with from ten to twenty per cent. less coal than a locomotive developing the same power and not provided with a superheater. Less coal being required, there will consequently be less smoke. The brick arch, by retaining heat and retarding the flow of the gases, permits their ignition, while without the arch they would escape without reaching the ignition point, and a portion at least would form smoke. The amount of smoke reduction, although comparatively small, is sufficient to warrant consideration, and application of arches alone or in combination with the other devices mentioned.

#### SPECIAL INSTRUCTION OF THE MEN.

Instruction and supervision are necessary to some extent, even when the mechanical devices named above are used. The cost of fuel represents from 8 to 10 per cent. of the total operating cost of the railway and therefore one of the most obvious ways of reducing operating expenses is to economize in the use of fuel. As the methods which must be followed to obtain the maximum economy in locomotive fuel consumption are the same as those necessary to reduce smoke, the direct financial interest of the railway is the elimination of smoke. Therefore, in addition to the study and development of mechanical devices the railways, by additional supervisors and instructors, are causing reduction in the amount of smoke emitted by having more careful firing and handling of locomotives by the enginemen. At many points the subject of smoke abatement is assigned to men whose sole duty is to observe the amount of smoke produced and instruct the enginemen as to its prevention.

In some localities, where the locomotives of several roads operate over one another's tracks, the inspectors represent the several railways and report to the proper officer the emission of dense smoke from any locomotive, regardless of its ownership. Such an arrangement is particularly desirable at points where the lines of several railways are adjacent, as it permits a comparatively small number of men to observe a large number of locomotives.

Following is an extract from the instructions of the Pennsylvania Railroad regarding the abatement of smoke:

"Enginemen and firemen must work together so as to save coal and reduce smoke.

"The burning of bituminous coal in a locomotive requires air, which must be admitted through the grates and through the fire door.

"Smoke means waste of coal and must be avoided.

"Large quantities of coal placed in the firebox at one time cool down the fire, cause smoke and waste coal. Small quantities at regular intervals will keep the fire bright, prevent smoke and take less coal to keep up steam pressure.

"Lumps of coal should be broken in pieces not larger than 3 in. A bright and level fire over the whole grate must be carried wherever possible. When a sloping fire is used, no more coal should be banked at the door than is necessary.

"To prevent smoke and to save coal, the fire door must be placed on or against the latch after firing coal or using the scraper, slash bar, or hook, and when on siding, in yard, at terminals, or before starting.

"Before the throttle is closed, the blower must be used and the door placed on the latch.

"Firemen must stop firing long enough before steam is shut off to prevent smoke and waste of coal."

#### ENGINE HOUSE SMOKE.

Perhaps the most difficult problem in the abatement of smoke from locomotives is the reduction of the amount of smoke

made at the locomotive terminals, where fresh fires are made, to prepare the locomotives for service.

At the present time the Pennsylvania Lines have under construction, at the engine house in Allegheny, apparatus to carry the smoke and gases from the locomotives in which fires are being prepared, through an underground duct and a fan, discharging them into a stack 150 ft. high, 7 ft. in diameter. It is felt that this arrangement will not only carry the smoke and gases considerably above the buildings immediately adjacent to the engine house, but, owing to the size of the stack, permit of considerable precipitation of the heavier particles. The stack will be so located that it will be possible to interpose smoke washing apparatus between it and the fan, should a sufficiently promising method be developed. Mention is made of this only to inform you that all phases of the subject are receiving the careful attention of the railway officials, and that the railways are making expenditures of considerable magnitude in their endeavors to abate smoke.

#### ELIMINATION OF THE STEAM LOCOMOTIVE.

In the present state of the art, of course, this means the substitution of electric motive power for all the locomotives now in use, as no other method is now available. The word "electrification" seems to be attractive to everyone, save those charged with the responsibility of obtaining the money required to meet the enormous outlay of capital required to install the apparatus and then to continue the operation at rates for carrying passengers and freight which will be deemed reasonable by the patrons, as it has not been demonstrated that electrification will generally result in reduced operating costs.

From the best data available the complete electrification of the railways would eliminate some 20 per cent. of the smoke annoyance, and I have often wondered why its application, to ameliorate the discomforts caused by the remaining 80 per cent., was not more strongly urged. Undoubtedly electric power may be substituted for steam power for many purposes for much less capital outlay, with more promise of a satisfactory return on the investment and with less probability of unsatisfactory service to patrons, than is the case with its use by the railways.

From the information offered by many writers on the subject, one would be led to believe that a steam locomotive is a most wasteful machine and that tremendous savings would result from abandoning their use. As a matter of fact, the performance of the locomotive boiler compares favorably with the average results obtained in stationary practice, and the performance of the complete locomotive, of modern construction, is sufficiently efficient to permit of obtaining a coal rate of 2.1 lbs. per indicator horse power hour, or 2.5 lbs. of coal per horse power hour delivered at the drawbar of the tender. Surely such results do not warrant the almost general belief that the locomotive is an inefficient machine for the purpose for which it is intended.

Without doubt the use of electric motive power in lieu of the steam locomotive will be extended, but its use will, at least until there is great improvement in the efficiency, reliability and reduction of the cost of electrical apparatus and its operation, be confined to meeting special conditions, such as the operation of the lines through tunnels, similar to those under the rivers at New York and Detroit, those in long tunnels through mountains, and certain lines with exceedingly heavy grades and a large volume of traffic, as well as some terminal passenger stations where the location and traffic conditions are such as to readily permit of its adoption.

The cost of everything electric is enormous. The cost of the electric locomotive is at least double that of the steam locomotive, which it is supposed to replace, and before electric locomotives can be operated it is necessary to incur a large additional outlay for power houses, transmission systems, track preparation and all of the other apparatus and material which is necessary to complete an electric system. One estimate which

has been brought to my attention provides an investment of about \$200,000 for each steam locomotive displaced, or about ten times the cost of each of the latter. As there are about 70,000 locomotives in the United States, representing an investment of about one billion four hundred million dollars, you will agree with me that some exceptionally favorable return must be apparent before they will all be discarded; especially so when their replacement involves an expenditure of many times their present value.

It is true that the demand is rarely made that an entire cross country line be operated by electric power, but that such operations be confined to the larger cities. Such an installation, however, except under particularly favorable conditions, involves not only a proportionately heavier investment for the electric plant, but requires the establishment of two locomotive terminals, one each side of the city, and an additional stop at each of the termini for an exchange of the steam for an electric locomotive or vice versa. Even if the railways could stand the burden of the cost, it is doubtful if the traveling public would tolerate frequent delays of this kind.

While, of course, with an unlimited expenditure of money much might be accomplished by electrification of the railways, to reduce the proportion of smoke now produced by them, it would seem wise to first provide for the transportation and terminal facilities required to meet the growing needs of our country's commerce, and the elimination of grade crossings, etc., before devoting any considerable sum to eliminating a comparatively small amount of the smoke in a particular community.

## TRAINING THE RAILWAY EMPLOYEE.\*

By A. KIPP,

Mechanical Superintendent, Minneapolis, St. Paul & Sault Ste. Marie.

The railway official has, as one of his problems, the training of men to fill positions of responsibility. He has to develop the capacity of men, coming from the ranks, so that they are broadened to carry the responsibilities that go hand in hand with the administration of the affairs of which they are to have control. In addition to this, he must meet a condition which is growing rapidly, necessitating a broader training for the men of the rank and file. The corporation and its employees have, as a result of the progress of organization, grown apart, and plans through which a better understanding and a more sympathetic feeling can be introduced, seem desirable and necessary.

In the case of the individual there seems to be a demand for a training better and more thorough than that which is the usual course followed by the men coming from the ranks. It frequently happens that a man is selected and put into a position without having had any previous knowledge of such an action on the part of his superiors and with no coaching. He frequently fills the position in which he is placed, broadening the best he can with his own efforts, as he goes along, carrying the responsibilities of his position with all the work attached to it, and with no particular well defined scheme in which he can prepare himself for a higher efficiency and greater responsibilities.

Only recently have we read in one of the railway papers the question: "Why do not young men with a college training remain in the railway service?" This question has often been discussed, and while the railways have retained a large number of college men, it is true that a good many capable men who have obtained a college training have entered the railway service, only to give it up after they have surveyed the field of their future employment. They have realized the odds against which they have to work, and the future in store for them, which is their probable compensation for the years of toil, they would have to serve to reach the end. These men have found other lines giving them greater opportunities for development and higher rewards for ability and energy. The man who has not

had the opportunity of the college graduate, but has the same ambition to do things and develop to his maximum capacity, when coming from the ranks, has had to accept the handicap, where the college man has been able to get away from it.

The opportunity of developing capacity through habit of thought should be given the man long before he leaves the ranks. Judgment develops with practice, it is true, but it is surer when the habit of thought has been directed along the right lines. It is, therefore, a safe plan to pick out the man in the ranks, guiding him, possibly long before he is needed, for a position of higher responsibility. He should be given an opportunity to adjust his view point while he is still in the ranks. When he finally reaches the first step beyond the ranks and becomes a foreman, a train-master, or has a position of a similar nature, there is a possibility of developing his capacity beyond what it will be by confining him strictly to his responsibilities and duties, if he is taken into the confidence of his superiors, by being given an insight into the work beyond his daily tasks, or in other words, if he is schooled to give him an insight into larger problems that will broaden his usefulness and prepare him for the future.

The broad field of work of the railway clubs has its direct bearing on this training. Because of the education which it is possible for the members to obtain when taking an active part in them, they should be encouraged. Possibly the attendance at the meetings of this club would be greatly increased to the mutual good of its members and the organizations they serve if the men were to receive greater encouragement in their attendance upon these meetings.

To the men in the ranks is due the education, with the purpose back of it, of training them to see the relations which may and should exist between them and their employers, resulting in greater sympathy and creating an *esprit de corps* so much to be desired in any organization. We have, on innumerable occasions, been made to feel the influence that has been and is being brought to bear on the men in the ranks, teaching only one side of their existence and of the relations of the employer to the employee. We need a stronger counter-influence generally, and this can only be accomplished by means of education. It is the duty of the employer, or in other words, the officers who are responsible for the administration of affairs, to provide a means by which such training can be given. We do not believe that there has been a sufficient progress made along these lines.

The study of efficiency has many students, and considerable thought is being given to getting the best result from individual effort, or the greatest product from a dollar's expenditure. Efficiency engineers are reorganizing shop methods and systems of accounting. They are putting men on piece rates and are suggesting methods of educating them to produce the greatest amount with the fewest movements. This is efficiency. These activities are directly in the line of progress and will have their successful end, but there are other means of education that are worthy of consideration.

The young men in our mechanical trades are learning them through apprenticeships, in which they are given a prescribed course of instruction, or they are learning by means of promotions from one class of work to another, until they have obtained a knowledge of the trade. This, in a large number of our shops, extends only over the practical training in the operations to be performed. On some systems they are going further, in giving a training in mathematics and drawing.

Locomotive engineers and conductors are trained for their positions through an apprenticeship course as fireman or brakeman. While serving in this capacity they must necessarily receive a large part of their instruction from the engineer or the conductor, supplemented by that given by their superiors. The amount of instruction coming from the officer varies considerably, depending upon the territory and number of men he has to control. The training is further supplemented by the air brake instructor and in some cases the fuel instructor. Instruction cars, in charge of these latter men, are in extensive use. The enginemen are stimulated to study the mechanisms of locomotives, the principle of

\*A paper presented to the Western Railway Club, October 21.



combustion, etc., to meet examinations. Such systems have their usefulness and are quite necessary.

We believe, however, that a greater degree of training is advisable. We believe there is good ground for rapid extension of the systems found in some of the organizations where shopmen are given courses in mathematics and mechanical drawing. In such courses there is an opportunity to develop the minds of the younger men and start their thought habits in the right direction. The idea of a better education for the boys of those classes is gaining ground. This has invaded the precincts of the state legislature. In Wisconsin there is an apprenticeship law, made effective in June, 1911, which is the common-piece to a law authorizing the extension of industrial education. The object of this statute is the establishing of the well known indenture system, in which the young man contracts with the employer under an agreement, a part of which is that he shall receive a training outside of the shop training, including instruction in English, business practice, physiology, hygiene and the use of safety devices. The law is modeled closely after those existent in Germany, which, it is claimed, have worked admirably. It may not be advisable to extend such an education to men in the road service or in other departments, but a clearer understanding of the problems of political economy and sociology could be given these men through lectures and literature. Some railways have already adopted the magazine, through whose pages all of the employees can be reached in a most effective way.

It is the plan of some railways to stimulate the employee to the feeling that he is a part of the organization and to encourage the feeling of security in a life position, for which he is eligible as long as he performs his work efficiently. This is done through the pension system. This, in short, is a method of retiring employees who have become too old to perform efficient service, or for whom the work has become too strenuous, and of compensating them on a basis of their previous income and their length of service. The usual practice, I believe, has been to pay an equivalent of one per cent. for every year's continuous service of the average income of the last ten years of that service. The usual age limit is 70 years, beyond which there is no discretion given for continuing service. A good practice, however, followed in some cases, is that of making the minimum limit 65 years, with discretion given the employee and the employer for continued service up to the seventieth birthday.

Another feature, which has probably not been extended as far as the pension system, but is worthy of consideration, is that of forming an association among the employees to serve as a savings association. Such a system may be best explained by an outline of such an organization formed by the employees of the Soo Line, which organization has been made possible by the hearty support of the officials of that company. This is known as the Soo Line Co-Operative Association. The object, as stated in the articles of incorporation and by-laws, is:

To fraternize the employees of the Minneapolis, St. Paul & Sault Ste. Marie Railway Company and its subsidiary companies.

To encourage its members to systematically save some portion of their income, the purpose being to combine the small savings of the many employees and to make it possible for the saver of small amounts to have a profitable investment for his or her savings.

To invest the combined savings of its members in securities of the company.

To bring about the general co-operation of members towards the best and most economical service for their company, so that the association's investment will make the best possible returns to its members.

To be the means of bringing employees into closer touch and harmony, acquainting each and every one with the fact that each one, no matter what the position occupied, is or should be working to give the public the best possible service, making the railway a greater benefit to all the communities it serves.

All members of the association are put on an equal footing, each member having one vote, regardless of his subscription. Each month there is deposited with the treasurer of the association, a given amount, previously subscribed. The funds thus accruing are invested in Soo Line securities. An association of this kind puts into the hands of the employee of the lowest degree the opportunity, not only to save, but to invest immediately

a small saving, though it may be but \$1 a month. It gives an added interest in the organization for which he is working. The advantages to the employee can readily be seen and the power of such an organization for mutual benefit can well be understood.

In a recent conversation with a locomotive engineer, who had been in the service of his company since 1882, we were told that he had been purchasing some of the railroad company's bonds, and that he had decided that that was about as good a thing as he could do with his money, and he added: "And I want to tell you that it makes a fellow feel a whole lot different. He has an added interest, feeling that he owns some of those spikes and ties that he is running over." He told of one of his associates, a man who had been afraid to invest his money, but who kept a great deal of it in safety deposit vaults. This man had been persuaded to purchase some of the same bonds. His attitude and the feeling he had toward the company was thus changed very considerably. Both of these men had been the kind we considered loyal, men of the old school.

Associations of this nature, investing either in the securities of the company, or even advancing the welfare of the men along the line of building associations, encouraging them to build homes in their towns or cities, are bound to build up a spirit among the employees which can be considered a valuable asset.

In addition to this, there are welfare systems which are now being given serious consideration, such as the organization of "safety first" committees, and instruction along the lines of personal safety. A great deal has been written of this commendable movement and it needs no explanation other than the comment that it has its place in the organization.

Associations similar to the Railroad Y. M. C. A., established at terminals and near repair shops, giving men club-houses where they can get accommodations, and can meet associates in an environment of a higher level than those they will find in saloons, are most commendable.

Rule "G" in the American Code, is one which must be enforced more than it has ever been before, but the logical way to enforce the rule is through the exertion of an influence, if not the real expenditure of capital, toward the introduction of community or club-houses, which will furnish the environment so necessary to combat the bad influence into which men, particularly those without families, often drift.

The world has had many natural leaders, men who by sheer force of character have been able to carry with them the masses with whom they come in contact. Such men are not numerous. They are not developed for the needs of every organization, and without such men an organization must have some power to accomplish the same result. It is safer to build up an organization, the official roster of which is composed of men loyal to the organization, and not to a man, and with rank and file trained to an appreciation of their relation to the organization. Such an organization will outlive that based upon the one-man power.

**ARGENTINE RAILWAY PLANS.**—The government of the Province of Buenos Aires recently obtained the sanction of the provincial senate to construct a series of branches from the La Plata-Meridian V. Railway. The length of the projected lines totals about 2,500 miles, and the cost is estimated at \$125,000,000. As a beginning, it is proposed to build 450 miles, the cost of which is to be met by increasing by \$17,000,000 the amount of the bonds authorized to be issued by the laws of 1907 and 1912. Several senators opposed the project, and the leading journals have severely criticized the scheme, on the ground that it affects the rights and existence of the concessions of railways granted to British and other private companies. It may be pointed out that the province has no cause for complaint as regards lack of railway communications. The length of lines constructed and in operation is already greater in proportion to the area of the province and its population. Consequently, there is a large percentage of available carrying capacity that is not being utilized at all.

## THE RAILWAY SITUATION AND ITS CAUSES.\*

BY BLEWETT LEE,

General Solicitor, Illinois Central Railroad.

When a man gets to be old there is something very unpleasant and unfortunate which happens to him. It is hardening of the arteries. The blood vessels lose their elasticity and grip. They refuse to stretch any more. The blood pressure becomes dangerous, and by and by the man dies.

The railroads of this country are its arteries, and traffic is its life blood. The business of the country is growing almost by leaps and bounds, but the railroads do not grow to keep pace with it. The railroads are scarcely growing at all. They need more lines, more branches, more tracks, more terminals, more cars, more everything. Unless this situation changes, the business of the country will be bursting its arteries.

What is the matter? The railroad men tell you they can't borrow the money necessary to make these improvements. The companies are, many of them, living from hand to mouth on short-term notes. At this very time three of the great western systems are in the hands of receivers, the Wabash, the Frisco, and the Pere Marquette. Why can't the railroads borrow money? Well, thereby hangs a tale.

In the first place, prices of all supplies have gone up. Everywhere the railroads have to pay more money for what they need. The decrease in the cost of production of gold or some other reason has reduced the value of a dollar until it will not buy anything like what it did a few years ago. The average receipts per ton-mile have changed very little since 1900, but the purchasing power of the money has declined on the average at least 25 per cent. The yardstick is being shortened all the time.

In the second place, the wages of labor have risen and are rising like a steady tide. Not that I blame the laborers for trying to get more wages—for wages have not risen as fast as the cost of living—but I do think the laborers are demanding more than the railroads can afford to pay. The national labor organizations are stronger than the railroads. Every threatened strike means an arbitration, and every arbitration means a compromise, and every compromise means a further depletion of the meager revenues of the railroads. It is not generally known that one of the chief obstacles to electrification is the insistent demand of the engineers' and trainmen's organizations that the men, who do the work of a motorman on an interurban line, shall receive the same pay as a locomotive engineer. It is obvious that this demand, which the railroad companies are not strong enough to resist, practically deprives the public of the economy of electrification, and indeed takes from electrification the most important economy which it has to offer.

By comparing the statistics of the Interstate Commerce Commission for 1902 and 1912 it will be found that while the total operating revenues have increased 64.6 per cent. the total operating expenses have increased 75.5 per cent., of which the total compensation of employees increased 84.9 per cent., as compared with the total other expenses which have increased 61.1 per cent. The ratio of compensation of employees to the total earnings which was 38.9 per cent. in 1902, rose to 43.9 per cent. in 1912, and the ratio of compensation of employees to total expenses rose from 62.4 per cent. in 1902 to a total of 63.4 per cent. in 1912. As against this, the average rate per passenger mile in the United States in 1902 was 1.986 cents, and in 1912 it was 1.985 cents.; and in 1902 the average rate per ton mile was .753 cent, and in 1912, .743 cent. In other words, both passenger and freight rates were lower at the end of the decade than they were at its beginning. Labor is getting the best of it, both absolutely and relatively. The railroads pay out about a billion and a quarter dollars a year in wages.

In the third place, the heavy hand of legislation, state and federal, is laid upon the railroads. We are being stoned to death with statutes. The government has taken all the privileges

of ownership with none of its responsibilities. In Europe cars are still coupled on the link and pin plan. Why? Because after careful inquiry the governments found the railroads could not with their present earnings afford the expense of changing all their equipment. Imagine such an answer as that being taken in this country! Why, a railroad man who had the nerve to stand on that position would be thrown to the newspapers. They would make "Mellen's food" of him. Railroads are the great popular plaything. There is more and more legislation all the time which wears the amiable mask of care for the public safety, but is really intended to force the employment of unnecessary men, to strengthen the monopoly of employment in the hands of the great unions, to compel the purchase of favored illuminating or safety devices, or to force the erection of decorative depots, veritable cathedrals of industry, in obscure communities. Population between 1890 and 1910 increased 47 per cent., but the number of railroad employees 109 per cent.

In the fourth place, there is the steady progress of rate reduction, sometimes by the direct action of the legislature, as where by law passengers are compelled to be carried without profit, the freight-shipping public being saddled with part of the expenses of the traveling public, or by the pull down of this rate or that by commission action, each reduction, as you gentlemen very well understand, automatically pulling down a lot of other rates not reduced by name. A railroad now has to haul an average ton of freight two and a half miles to earn a postage stamp. The Interstate Commerce Commission, I am glad to say, is beginning to go slower about rate reduction in view of the stop which has come to new railroad construction in the country. The state commissions, however, are not disturbed by little symptoms of that kind, but following the glorious example of Texas, continue to punish Wall Street, and incidentally themselves, as opportunity offers. There are exceptions to this, notably in case of the Wisconsin Commission, which has administered its great office as a public trust. But many of the commissioners in other states, who are for the most part ridiculously underpaid, look upon their positions simply as political stepping-stones to the governorship, or what not, and insist all the time on playing St. George to the railroad's dragon.

Fifthly, there is the overtaxation of railroads. In many communities railroad taxes have more than doubled in the last ten years. They are now paying more than \$120,000,000 a year taxes. Railroads really ought not to be taxed at all. If necessary, rates should be reduced instead, for in the nature of things all the taxes which they pay they necessarily collect over again from the people. A tax on railroads is a tax on shippers. It is indirect taxation of the people based upon their necessities instead of direct taxation, based upon their capacity to pay. But you couldn't make the average citizen see that obvious fact—he has an idea perhaps that railroads literally make money, or possibly inherit it from rich uncles. The stupid process of piling up the taxes on railroads leaves them with less and less money for needed improvements, and instead of permitting a reduction of rates, makes an increase inevitable. One dollar in every six of net operating income is now taken for taxes. The wages and taxes paid by railroads amount to nearly four times as much as the dividends paid on their stock.

Sixthly, the growth of personal injury litigation has become a serious factor in the railroad financial situation. In spite of the fact that such injuries are not increasing, but are diminishing in numbers, notwithstanding the increase of traffic, the amounts paid in damage suits and settlements have enormously increased. Between 1908 and 1912 the number of passengers carried increased about 15 per cent. There were, nevertheless, only 114 passenger fatalities in 1912 as compared with 148 in 1908 and only 621 employee fatalities as against 659 in 1908. Notwithstanding this, there was a heavy increase of the amounts paid out for personal injuries. Indeed, in the thirteen years between 1899 and 1912 the amount paid by the railways of the United States for injuries to persons increased 288 per cent. The railroads of the country are bleeding at every pore from this character of

\*An address delivered before the Transportation Club of Indianapolis, Ind., on September 29.

litigation. Certain localities have distinguished themselves by extravagant verdicts and suits are being brought in these places from all over the country. Bleeding railroad companies in this way has become a highly organized industry which laughs to scorn the feeble fulminations of the common law against champerty and maintenance.

Still another consideration is the rise of the rate of interest in corporate finance. Instead of borrowing at four per cent. even the most fortunate corporations now, and probably for a long time in future, will have to pay at least five per cent. for long time money upon the best security, with rates correspondingly higher on short loans.

What is going to be the outcome of all this? The ultimate result, I fear, is government ownership, with worse administration of the railroads than ever before, and practically no remedy or redress for its shortcomings. We will then be about as helpless about our freight as we now are about our mail. Meanwhile we can only pray:

Be near us when our goods  
Are slipping o'er the brink;  
We are nearer government ownership today  
Perhaps than now we think.

What is to be done about it? Why, there is only one thing that offers any present hope of relief, and that is a moderate but general increase of freight rates. Just as long as the relative adjustment of rates is not changed, nobody would be seriously hurt, and the railroads would be able to show the bankers such a balance sheet as would justify the necessary loans. That is the remedy that England is applying today, and that is wise business sense in America, too, and wise statesmanship, also, for it would be ultimately for the benefit of the whole public.

Now, I confess that I am not very hopeful that the necessary thing will be done, for it requires an amount of moral courage on the part of public men which is painfully absent in public life. To do the presently unpopular thing for the sake of the distant and certain public good takes a certain heroic quality which is very rare. No man wants to be a martyr. What is more likely to happen is that the railroads will continue to sit tight and hold on to every dollar they can, until the pressure of the inevitable increase of business becomes so great that even at present rates they will be able to make a living. Slowly from the grinding necessities of a reluctant people at last by bitter experience will be extorted a sufficient reward to capital to induce further investments in railroad property.

The mills of God grind slowly,  
But they grind exceeding small;  
Tho' with patience He stands waiting,  
With exactness He pays all.

The short-sighted greed which compels carriers to work for less than a living wage, will be succeeded by the want, the pressing want, of railroad facilities with no means to get them, for nobody on earth can be compelled to send good money after bad. In the present state of affairs in this country investments in railroads are bad money, and until they are made good money by better rates and fairer legislation, the savings will not be coaxed out of eastern and European strong boxes. The ancient call of "Ducky, ducky, come up and be plucked," has somehow lost its charm, and those bond-buying savings banks have developed a wholesome fear about not getting their interest on new railroad investments. The necessity for improvements is upon us, the money is really there, but the confidence is lacking, and in all frankness it ought to be lacking until a change comes over the treatment which the state gives to its railways.

**SHORT LINES FOR SCOTLAND.**—The contract for new lines in the coal districts of the counties of Edinburgh and Haddington, Scotland, has been awarded by the North British Railway to Hugh Symington & Sons, Ltd., Glasgow. The estimated value of the contract is \$803,000. There will be four miles of double track and three miles of single track, besides six miles of side tracks. About 35 culverts are included in the contract.

## AN EARLY LOCOMOTIVE BOILER EXPLOSION.

An article was published in the *Daily Railway Age Gazette* of June 16, 1913, illustrating the headstones of an engineer and fireman who were killed by a locomotive boiler explosion in 1840. The statement was made that this locomotive was built by Norris & Company, of Philadelphia. In the *Railway Age Gazette* of July 18, Clement V. Stretton directed attention to the fact that the locomotive was built in Birmingham, England, and not in America. In support of this statement one of our friends has very kindly sent us a copy of a report made to the Railway Department of the Board of Trade by the secretary of the Birmingham & Gloucester Railway, on which the accident occurred. The letter follows:

BIRMINGHAM, 14 November, 1840.

Sir:—It becomes my painful duty to report to the Lords of the Privy Council for Trade, a melancholy accident which occurred at the Bromsgrove Station on this railway, on Tuesday the 10th instant, by the bursting of an engine boiler. The engine was of a peculiar construction, having been made about 3 years ago by Dr. Church of this place, and soon after tried both on the London and Birmingham and Grand Junction Railways. It was then found necessary to make some alterations for the purpose of producing steam more quickly, but not at all affecting the safety of the engine. The engine then passed into the hands of Mr. S. A. Goddard of this place, and a short time since, the necessary alteration being made, he applied to the directors of this company to allow a trial of the engine, stating, at the same time, that his object was to sell this engine to the company, and make others like it for sale. The company's engineer of locomotives and his foreman were sent to examine the engine, and they having reported favourably of it, the directors allowed the trial. The engine was consequently placed on the line, and put under trial before proceeding to use it. On the occasion of the steam being got up the second time, and after several short runs had been made, but the engine being stationary at the time, the boiler burst, and Thomas Scaife, one of the company's best drivers, was killed on the spot. John Rutherford, the fireman of the engine, was so much injured that he survived only about 12 hours. Thomas Williams, another of the company's servants, and Edward Paul, a stoker, in the employ of Mr. Goddard, were also severely hurt, but are doing well. The engine-man in the employ of Mr. Goddard, and who was in charge of the engine, and two or three other persons, were slightly hurt, but are very much recovered. A coroner's jury has sat upon the bodies. The evidence goes to show that no neglect or want of caution existed on the part of the company's servants; but that the boiler plate, although it had resisted a much higher pressure of steam than it then had on it, was not strong enough. The inquest is adjourned until next Monday week, for the purpose of affording the boiler-maker an opportunity of giving evidence.

I am, etc.,

Wm. Burgess, Sec.

S. LAING, Esq.,  
Railway Dept., Board of Trade.

**THE LOETSCHBERG RAILWAY, SWITZERLAND.**—The completion and opening of the Loetschberg Railway with a tunnel ten miles in length, which, with connecting lines, crosses Switzerland from north to south, has had an effect upon railway traffic in the Confederation that is international in character. Both freight and passenger traffic from the north of Europe, including Great Britain, France, Belgium and Germany, to Italy and countries to the east of Italy, have had up to the present two routes, the Gothard and the Simplon, the first of most value to Germany and the second to France; but now between these two there is the new line from Berne, through the Loetschberg to Brigue, and then through the Simplon into Italy and beyond. This new route is of particular value to Belgium and the north of France, as it shortens the journeys to Italy by a distance which is particularly important in the transportation of freight. The result is that the Gothard and the French route to the Simplon are suffering a loss of traffic to the Loetschberg. In order to maintain the business of the Gothard Railway the Swiss government has decided to improve the former route by the construction of a new approach from the west, and is building a new line by the Hanenstein, and when completed the improvements will shorten the route and at the same time overcome the heavy grades of the old line.

# Maintenance of Way Section.

THE report on cattle guards presented at the convention of the Bridge and Building Association at Montreal, this week, and abstracted on another page, brings out an interesting legal point. Cattle guards are required by law in a number of states, and yet full compliance with the law does not relieve a road from claims any more than if no cattle guards were installed. Coupled with this is the fact that in some states where the use of cattle guards is required, no penalties are provided for non-compliance. Because of these conditions several roads have discontinued the use of cattle guards. One road which has begun such action has found from careful analysis that its claims from sources affected by cattle guards have actually decreased since their elimination. Perhaps similar studies might reveal similar conditions on other roads.

AS many roads are now making their annual bridge inspection, the methods of conducting these inspections on different roads are of general interest. We plan to present in the November maintenance section descriptions of the methods used on different roads, including information concerning the intervals between inspections, the officers making them, the detail with which the structures are examined, the system of preparing and filing the information collected and the extent to which the information collected is used in the division and general offices in making up the repair and renewal program for the succeeding year. We will be glad to receive articles on this subject describing briefly various methods used, with their advantages and disadvantages, to be published with the papers arranged for. Such contributions should be sent to the Civil Engineering Editor, 608 South Dearborn street, Chicago, before November 6.

AT the annual banquet of the American Railway Engineering Association in March, 1912, President Loree of the Delaware & Hudson called attention to the fact that although 56 per cent. of the expenditures for maintenance of way were for labor, the attention of this association was concentrated almost entirely upon studies of material. As a result of Mr. Loree's discussion of the labor question, three committees are now studying different phases of the economies of maintenance of way labor, including various methods of arranging forces and work to increase the general efficiency. Many prominent operating and engineering officers believe that the most effective single measure would be materially to raise the pay of foremen, and thereby raise the standard of men in these positions. If the committees shall come to this conclusion, and recommend a minimum wage considerably in excess of that now paid, it will be interesting to see what action the Engineering Association will take, in view of the ultra-conservative attitude of the larger railway associations in dealing with any subject involving the question of wages. It would seem that if the facts justified a committee in reaching such a conclusion, it would be as appropriate for it to say so as to recommend a certain class of material to promote economy in maintenance.

THE burning of the floor of the upper, or highway, deck of the new Oregon-Washington Railroad & Navigation bridge at Portland, Oregon, a few weeks ago was an event unusual in the history of permanent bridge construction. That an accident of this nature serious enough to put the structure out of commission for all traffic, river as well as railway and street, should happen on a structure of the most modern design and in service less than a year, is sufficient in itself to attract the serious attention of engineers. The fact that this fire started in and was confined to a creosoted wood deck, such as is very generally used in similar construction on other railway, as well as highway bridges, raises a question regarding the suitability of this material for structures otherwise fireproof. A very similar fire occurred in the deck of the Burlington-Swift bridge at

Kansas City a short time before. Continuous and uninterrupted operation for both railway and river traffic is essential in the case of most large bridges, and large sums are spent to secure types of construction which will insure this. The effects of creosote treatment on the fire resisting properties of timber have been studied for a number of years, and the consensus of opinion has been that this treatment increases the initial resistance enough to ward off most fires, but that, once started, a fire in such timber is extremely difficult to put out. Although its cause is somewhat uncertain the fire at Portland confirms the latter part of this opinion, for the oil exuding from the timber under the intense heat added fuel to the fire and water had little or no effect on it. Such a fire is unusually hot and the damage to steel work is therefore intensified. At Portland over 100 tons of steel were so injured as to require replacement, while the lifting cables were entirely burned off. It may be that further investigations will show that the fire resisting properties of creosote treatment have been overestimated, and that successful design will require the use of some more fireproof material on permanent structures. It is interesting to note that in repairing the bridge at Kansas City the damaged portions of the wood block floor were replaced with concrete. The fire hazard of wood blocks for this type of construction is at least worthy of serious consideration.

## THE RAILWAY TRACK LABOR PROBLEM.

THE labor problem has been brought more forcibly to the attention of railway officers in the maintenance of way department within the last two years than ever before. Although the amount of work under way has not been unusually large, it has been seriously delayed by a shortage of labor, and in some cases has had to be suspended altogether. There is no immediate prospect of this condition being materially improved; but many are studying the situation very carefully in an endeavor to find some means of attracting more labor into maintenance work and also of utilizing more fully the supply of labor available.

As indicated in the papers on the subject on another page, the rate of wage is not the only consideration, and frequently is not even the main difficulty in securing the full quota of forces desired. The most important essential is that of permanent employment throughout the year. Present practice is generally recognized as extremely wasteful of labor in this regard. It is the general custom to crowd as much of the track work as possible into the months from May to October, inclusive. The result is that not enough men can be secured during the summer, while thousands are idle during the remaining six months. To overcome this difficulty to a degree, the Central Railroad of New Jersey, the Lehigh Valley and some other roads now lay their rail during the winter. The Long Island has met the issue by reorganizing its work upon a yearly instead of a summer basis, and, as pointed out by Mr. King, it is already securing very promising results, although the plan has not received a sufficient trial to enable definite conclusions to be drawn. However, it is common experience that comparatively little difficulty is encountered in holding throughout the summer those men who are retained during the winter. It is the men employed for only a few months that it is difficult to hire, and more difficult to get efficient work from. With permanent employment, better men will be attracted and will be willing to work for less than the summer rate paid by contractors and in other industries, because their total income for the year will exceed that received in the temporary employment.

Second only to permanent employment in importance as a means of holding men, is attention to their comfort. With the withdrawal of the better class of laborers into other industries, the character of the accommodations provided for the men has

seriously declined until these accommodations are in many cases sufficient in themselves to drive good men into other employment. Within the past two years there has been a marked tendency toward providing better cars and houses, closer supervision over the food furnished, increased medical attention and more sanitary surroundings, with the result that camps of the better class are not only comparatively free from sickness, but also maintain more closely their full quota of men. The "personal equation" of the foreman is another strong factor in holding men. The foreman who can impress his men with his knowledge of the work and with his fairness need not be a "driver" to get work done. In fact, he is apt to get more done ultimately if he is not a "driver." In this connection an indirect but very important result of raising the general standard of men in track work will be to provide better material from which to select foremen. The very general deterioration in the quality of foremen is one of the causes leading to the present shortage of labor.

The wage question is important, not alone as regards the rate paid, but also as respects its adaptation to local and changing conditions. To secure track labor a railway must compete for labor with industries along its lines. The rate necessary to secure laborers is not necessarily the same over a system, or even a division. Likewise, a rate which will secure competent men in April will many times not hold them in July or August when the demands in other lines of business are greater. A serious difficulty in holding men lies in the inability promptly to secure authority to increase the rates from an officer at headquarters, perhaps several hundred miles away, and unfamiliar with conditions. The employment of local laborers living at home is economical for the roads in nearly every case, but they cannot be retained if rates of pay are fixed without regard to local conditions. To replace native labor, which has left a gang with foreign labor at the same rate will nearly always drive any native laborers who may be left into other work.

If present tendencies are an indication of the future, we will see within the next few years much greater development along the line of readjusting the year's work so as to increase the proportion of men permanently employed throughout the year, while the scale of living provided for employees in the track department will be materially raised, and more attention will be paid to the intelligent supervision of labor in this department. Those in immediate charge of track work can do much to improve conditions, not only by endeavoring to impress upon their superior officers the importance of this subject, but by employing many of the measures suggested on their own divisions, for the adoption of some of these methods is within the authority of the division officers. In fact, on nearly every road one can find cases of supervisors who have given serious attention to the labor problem, with the result that their labor troubles are not as acute as those on adjoining divisions.

#### NEW BOOKS.

*Reinforced Concrete Wall Footings and Column Footings.* By Arthur N. Talbot, professor of Municipal and Sanitary Engineering, University of Illinois. Size 6 in. by 9 in., 114 pages, paper binding. Published by University of Illinois. Price \$0.50.

This book has just been issued as bulletin No. 67 of the Engineering Experiment Station of the University of Illinois. The load on a building or other structure is transmitted to the earth through the footings under the walls and columns. Uncertainties exist in regard to the strength of footings and to the magnitude and distribution of the stresses. This bulletin gives the results of an important and extensive series of tests, in which footings were loaded in such a way as to approximate the conditions to be expected in structures. The tests indicate that certain elements of design have not always been given the proper consideration. This is the first set of tests of the kind known to have been made. Copies of bulletin No. 67 may be obtained upon application to W. F. M. Goss, director of the engineering experiment station University of Illinois, Urbana, Ill.

## Letters to the Editor.

### ONE ENGINEER'S VIEW.

New York, September 17, 1913.

TO THE EDITOR OF THE RAILWAY AGE GAZETTE:

In studying the means for holding laborers in maintenance of way work, so far as I can see, the only successful method now is to pay them high wages, keep them the entire year round, and don't ask them to do any work.

DIVISION ENGINEER.

### CONTRACTING OF MAINTENANCE WORK.

Topeka, Kan., September 23, 1913.

TO THE EDITOR OF THE RAILWAY AGE GAZETTE:

Referring to the committee report of the Roadmasters' Association abstracted in your issue of September 19, page 516. This subject should receive our careful consideration. I, for one, do not favor contracting maintenance work, as I have seen too much of it done, or, rather, half done. I believe in contracting large grading and concrete jobs and work of that nature requiring equipment not generally maintained. Such work as renewing rail and ties, inserting tie plates, ballasting track, and, in fact, all work pertaining to properly maintaining railroad track after it is once placed in operation, should be done by the railway company with its own gangs.

The first move a contractor will make is to get in touch with some roadmaster to secure a first class foreman experienced in that particular kind of work, and he will pay him from \$100 to \$125 per month. He will then select a first class outfit of tools, including hand cars or motor cars, and he and his foreman will collect a good crew of men adapted to the work in hand, paying them from \$2 to \$2.50 per day. In the end the railway company is in reality paying the wages of these men and in addition a profit for the contractor. We can save for our companies the contractor's profit by doing this work ourselves, as we already have the tools.

Nevertheless, it is a fact that the cost of track maintenance is increasing from year to year in a greater ratio than the traffic, and this increase is not entirely due to the high cost of tools or material.

I believe this increase is due to the track being too light for the traffic, to the labor in the maintenance department being too poor, and to the lack of sufficient supervision. The weight of cars and locomotives has increased very greatly within the last 15 years, and much of this equipment is still traveling over the 70-lb. and 75-lb. rail generally used at that time; for the increase in the weight of rail has by no means kept pace with that of the equipment. Why should we make the relatively small increases in the weight of rail from 75-lb. to 80-lb., 80-lb. to 90-lb., etc., filling our material yards with these switches, frogs and other fastenings which it is necessary to have in stock for emergency use? If a 75-lb. rail was necessary years ago we should have 120-lb. rails today. With reference to labor, if given the same kind of foremen and laborers as the contractor employs, the experienced roadmaster will outdistance the contractor in his work. Insufficient supervision may not apply on small roads as much as on the larger ones, but on the busy trunk line division a superintendent should have in charge of his track department an experienced man who can devote his entire time to working out the different problems which are presented. There is no department on the railway today where there is greater opportunity to "waste or save" money than in the track department. It requires a man thoroughly acquainted with every detail of track work to distribute the money allotted for labor and material where it will yield the best results.

A. E. HANSEN,

Roadmaster, Atchison, Topeka & Santa Fe.

# SUGGESTED MEANS FOR HOLDING LABORERS.

Discussion by Eight Men of Methods Which Have Assisted in Retaining Forces, Showing Wages Are Not Only Consideration.

## PRESENT OBSTACLES TO RETAINING LABOR.

By E. R. LEWIS.

Assistant to General Manager, Duluth, South Shore & Atlantic.

American railways employ a vast army of laborers of many nationalities, from many walks of life, for varied service, both temporary and permanent, and under various conditions in all parts of the country. The difficulties in obtaining and keeping these transient employees are in direct ratio with the diversity of conditions under which the workers and their employers exist, the governing law being that of supply and demand. Time was when unskilled labor was more than plentiful at \$1.10 per day; when laborers haunted the employment agencies; when employers picked and chose; when only the best of immigrant and native labor was afforded steady employment at what is now little more than half a wage. With the shrinkage of the purchasing power of the dollar, came the change in labor conditions. With the rapid settling of the country, the dawn of the great era of manufacturing, the increase in the pace of living, and the ever widening fields for employment, came the cry for workers and the competition at the seaports and other labor markets, for the services of brain and brawn.

The difficulties of the employer have increased from year to year. The railways especially have difficulty in obtaining and keeping men for the busy season to perform the manual labor which in a large measure makes possible the maintenance of our railways. Owing to diverse local conditions there is no royal road to the retention of labor. Manufactures, agriculture, mines and municipalities are in keen competition with transportation.

Each local labor market is more or less influenced by local conditions. Coastal districts are normally better supplied with unskilled labor than are interior districts. Those immigrants who early venture inland are for the most part individuals of comparatively marked independence of spirit, who remain in the ranks of unskilled labor but a little while, if they accept such work at all. They are seekers of fortune in this new world. They early become property owners and employers of labor.

But there is always a certain market price for which labor may be obtained. All other conditions notwithstanding, the way to keep labor is to pay the market price. "The laborer is worthy of his hire."

Undoubtedly the centralizing of railway authority tends to retard to some extent the free exercise of intelligence in the employment of labor. The man not on the ground and knowing little or nothing of the local demands of labor is at the helm. He handles the financial reins with an unseen and iron grip. The telegraphic order to reduce, to cut to the bone, regardless of the inevitable expense which accompanies a drastic and sudden change is unwelcomely familiar to every railway officer. There is a possibility that these financial spasms are of benefit to all in the end. That they work harm to the best management of the property for the time being, however, there seems no doubt.

The best interest of the maintenance of the permanent way of a railway company demands a certain expenditure of labor annually. If denied one year, the demand doubles. Although some new king of inexperience may make a temporary financial showing by robbing the permanent way of its labor for a year or more, he inevitably reaps the whirlwind. There is no possible escape from a certain fixed expenditure for a safe standard of excellence. Give the man on the ground a chance. What should it matter to the master whether labor in one town is paid the same as in another

so long as the result is satisfactory? Why insist that all men doing a certain thing the system over should be paid a certain wage when local conditions demand different market prices? Why not set aside a certain sum for a season's work on careful estimates and leave the details of the daily wage to the men on the ground? One of the gravest difficulties could thus be in great measure overcome. "Talent is something—tact is everything." Judgment of human nature is probably the most valuable attribute for a railway official. The best discipline, the best organization of labor is possible only when all the officers of a railway company know and heed the great lessons of the wisdom of life. No man who does not possess self control is capable of controlling others.

To control labor the employer must have intimate knowledge of labor's needs and of details of the work to be performed. The greatest want of the transportation companies of this country today is of officers who are versed in the details of the work of those under their control. How many railway officers on the headquarters staffs of our great railway lines take time to study details of the work of the departments they control? How many know the actual details of the simplest acts of skilled and unskilled labor? What excuse has any railway officer for not applying himself to learn these things? Routine duties form small excuse. It can be done and must be done to get the best results from labor. The railway official who spends some time among his men and says least, except in a kindly way, is on the right road to get the best results.

Labor is human, critical, discerning, appreciative of attention. Give to each man his full share of responsibility. Know how much he is capable of. Let him alone till he proves his own limit. Responsibility makes men. Study well each employer and insist that he study each laborer, and each laborer's place in the organization. In only such manner may the best discipline and the greatest degrees of efficiency be maintained. Efficiency retains labor. Inefficiency is quickly detected and deserted by labor. Choose carefully men who are to command labor.

Provide sufficient tools. Provide tools of efficient quality. See that they are well kept and used. The use of cheap, if poor tools, is false economy. It is hard to realize the far-reaching effects of unintelligent tool provision. No employer of labor who neglects to court criticism and suggestions on improvements in tools is worthy of his position.

Provision and care of quarters is often overlooked to the detriment of the retention of labor. The difficulties, especially with transient labor, are many. The work in hand is strenuous and exacting. The foremen in charge have little time to give to provision of bed and board. Both should be sanitary and reasonably comfortable. No excuse should be accepted for the reverse. These things may be accomplished at small expense with constant attention. If the men board themselves, they must be trained to cleanliness. If others have the quarters in hand, their retention may be made to depend on it. Close and constant supervision is necessary. Foremen who are required to eat at the table with their men have less food strikes than those who eat apart. In many cases labor may be best kept by providing cooks at the employer's expense, allowing the laborers themselves to provide the eatables and share the expense among themselves.

Interpreters with foreign-speaking laborers are seldom really necessary and are usually of evil influence. The reluctance of American born foremen to hiring foreign labor is largely the prejudice of ignorance. There are good laborers among men of every nation. Clannishness is human. Sym-

pathy, justice, understanding will overcome the reluctance with which foreign laborers accept our standards and forget their own. The employer's problem is to make the laborer "think right." He then is easily led to do right.

The nucleus of the great army of permanent railway labor is of and largely recruited from the section gang. The section is the favorite recruiting ground of all departments. The faithfulness of section labor is proverbial. To retain men on sections, first class permanent quarters, steady work and intelligent consideration are necessary. Winter reduction in wages and forces are necessary, but a fixed policy in the retention of a permanent staff at a certain winter wage assists largely in keeping men.

Foremen who cannot keep men should not be retained, if the failure is their personal fault. Foremen who possess those qualities which attract a following of laborers are invaluable. The personal element looms so large in the retention of labor, both permanent and transient, that it may almost be said to be more than half the battle.

Various forms of contracting both the temporary and permanent labor of railways may be followed with success. The payment of certain monthly lump sums (based on estimated total cost of gangs' wages) to foremen of section gangs, bridge gangs, freight handlers, carpenter gangs and others trustworthy and capable of hiring and paying laborers of their personal followings, and of performing the company's work in hand on a percentage or lump sum basis has been suggested and tried with good results.

The choice of methods for the retention of labor is the direct business of all concerned. It is essentially the particular business and should be made the especial study of "the man highest up," for his policy toward labor is unquestionably reflected in the acts of his subordinates and quickly molds the attitude of labor toward the corporation.

#### PERMANENT EMPLOYMENT AS A MEANS OF HOLDING LABORERS.

BY COLEMAN KING.

Supervisor, Long Island Railroad, Jamaica, N. Y.

The track labor situation is at the present time one of the most vital problems the maintenance of way department has to contend with, and many valuable suggestions have been made regarding means of obtaining and retaining laborers. Having devoted a great deal of thought and study to the labor situation during many years of actual experience in handling laborers, I have come to the conclusion that there is only one sure solution and that is permanent employment. In the case of section laborers, to which this paper specifically refers, a radical change in the system now generally in vogue on our American railroads must be put in force.

At present our section force fluctuates with the seasons. In the spring the section force is usually increased to the maximum for the year. New and inexperienced men are hired to fill up the gang to the full allowance. If labor is more plentiful than the demand and the rate of pay is approximately the same on sections as paid in other industries, a full crew of good men can readily be picked up by the section foreman locally or by the roadmaster at some central location where labor is more plentiful. However, it is safe to estimate that such easy means for getting labor is not feasible in one case in ten. Assuming that good laborers can be so readily secured it then develops that but a very small percentage of them have ever worked at track work, and it will take some time to make them competent track laborers.

How are we then going to get the other 90 per cent. of our authorized labor force. First, if the labor supply is greater than the demand and the rate paid by contractors is from 25 to 75 cents more per day for eight or nine hours than is paid on the section for ten hours, the good laborer will naturally engage employment at the higher rate of pay, especially since we cannot guarantee any longer term of

service than can the contractor. Consequently we get the poorer men that are left. A fair basis of comparison for these would be two of them equal to one good man. Second, if the conditions are the same as in the first instance with the one exception of the demand being greater than the supply, all the laborers we can expect to get are the few worthless ones that the contractor will not hire at any price, which results in an ultimate expenditure equal to an increase in the rate of pay of section laborers equivalent to that paid by contractors. Either one or the other of these conditions or a shortage in force below the allotment is the result.

Usually as soon as the heaviest part of the spring section work is done and about the time the annual tie renewals are made, when after three or four months' employment the new men begin to become efficient, a reduction of force is made. Along in the fall there may be another slight increase of raw recruits to get the track in fit condition before winter sets in, and again about the first of November there is a general reduction to a minimum winter force, which is so retained until spring unless temporarily increased because of snow trouble or possibly following a still greater reduction of force on account of a decrease in revenue due to a lull in traffic. With this continual fluctuation of section forces there is no possibility of obtaining efficiency. It is only a losing game for the railroads when they are compelled to pay two green men to obtain one competent man's work, which is virtually what is being done.

There is no more forceful inducement to any workman than permanent employment. The laborer who works eight months of the year for some contractor at the maximum daily rate of pay with four months of idleness during the winter staring him in the face, realizes that he would be much better off with steady employment at from 50 to 75 cents less per day, and also that permanent employment would produce efficiency in that particular line of work and would also create in him the ambition for possible promotion later on.

There is no doubt in my mind but that we could obtain better results with five competent laborers regularly employed than with an average of eight men under the fluctuating system. With a permanent force our work could be divided throughout the entire year and a great deal of the work now done in the early spring and summer could be done in the fall and early part of the winter. In fact, our climatic conditions in the greater part of the United States are such that much of this work could be done on many days throughout the winter months.

Now, in order to make my contention relative to a permanent as compared with a fluctuating force more clearly understood, we will assume that the force on a section averages three laborers during the four winter months and that the average force for the other eight months of the year is seven laborers. If averaged for the entire 12 months this assumed force will equal a uniform force of  $5\frac{1}{3}$  men per day.

Eliminating the  $\frac{2}{3}$  of a man would amount to \$1 at the rate of \$1.50 per day. We will divide this among the other five, making an increase in wages of 20 cents per day for each man, or \$1.70 per day. We now start out with five laborers, guaranteeing them steady employment at \$1.70 per day providing they give entire satisfaction and this without any additional cost to the railway company. Seeing the logic of our contention the management of the Long Island Railroad adopted the permanent section force system (a uniform number of men throughout the entire year) on May 16 of this year. At the same time the wages of section laborers were increased from \$1.50 to \$1.75 per day and a very material increase was made in the wages of section foremen. At that time the average wage paid by contractors was \$2 per day for eight or nine hours' work. When this new system went into effect each section foreman was given to understand clearly his duties under this system. He was to weed

out every poor man in his gang and replace them with good men (married men preferred), who were experienced in track work if possible. This weeding out was to be done as rapidly as he could get good men to take their places. Each foreman was given to understand clearly that he was held strictly accountable for the quality of men in his gang, and that no favoritism should be shown on account of relationship or friendship. This favoritism is generally shown among the Italians, to which nationality our track labor force and many of our foremen belong. He was given to understand that his work was to be systematized and apportioned to give him the opportunity to work to the best advantage throughout the entire year. When hired the laborer was given to understand that he was to be employed permanently at a fixed wage providing he gave perfect satisfaction in his work, was eligible for possible advancement provided he showed the necessary qualifications therefor and that he would not be dismissed from the service without good and sufficient cause.

Among the results secured to date are the following: Prior to the adoption of the permanent force practically 50 per cent. of this year's tie renewals were completed. Since then the balance of the ties have been put in. Our general track work has progressed so far that at the present time the track is in better condition than it was in at the same time one year ago. We are now making the necessary clean up preparatory for our annual track inspection earlier this year than usual in order to enable us to renew a part of our ties this fall and thus lessen the spring work. At the present time we have a good organization on our sections, consisting of the best men obtainable, whom we expect to retain, and obtain from them better results and greater efficiency by continued service. We have no dissatisfaction among the men, who are all endeavoring to do their best and thus be assured of permanent employment.

#### MEANS FOR HOLDING LABORERS.

By R. B. ABBOTT.

Division Engineer, Philadelphia & Reading, Harrisburg, Pa.

The most effective means of securing laborers is a wage rate high enough to make the position attractive. After the men are once in the service, the most important means of holding them is through the personality and capacity of the foreman.

Above all, a foreman must command the respect of his men by a display of real knowledge of the work and ability to teach. Next, he must treat his men with consideration and make them feel that he is their friend and that he will have an eye to their future. He must impress all this on them without encouraging or permitting undue familiarity and the consequent breaking down of the proper relation that should exist between every foreman and his men. The supervisors should preach this to the foremen, so that a feeling of mutual interest and understanding can be maintained all down the line. The foreman who has the respect, goodwill and confidence of his men can often hold them in the service even in the face of strenuous competition in the matter of wages alone. When the labor wage rate in outside pursuits rises considerably higher than that paid on a railroad, the foreman who first loses men is the one who has the least hold on their respect and regard. The greatest emphasis should be laid on the importance of steering away from the dangers that lie in a condition of undue familiarity, and only those who seem capable of bearing this constantly in mind should be advanced to positions of authority. Also an unreasonable and nagging section foreman can cause more trouble than anything else.

The factors that control the track labor situation here in the East can be grouped under three heads, rate of pay, location of section with regard to proximity to industrial centers, and personality and methods of the foremen. In farming

districts, as a rule, we have very little trouble in hiring men, as the rate of pay and the hours of service are attractive compared with working conditions on farms. In industrial centers, however, we have great difficulty in securing men and nearly all of our gangs at this time are short. This is due to the fact that laborers in other lines of work are paid more than we are able to offer and in many cases the working time is only eight hours.

In closing, the writer feels that a close study should be made of the wage rates in other occupations with a view to adjusting each local rate to suit the relative cost of living and the competition to be met. It is too often a fact that the wage rate paid to track laborers is the same all over a division or sub-division, even in the face of strong indications that the various section rates should vary with the conditions imposed by environment, etc. Furthermore, the adjustment should be made in due time so that experienced men will not drift away into other occupations where the grade of service is perhaps the same but the compensation greater.

#### THE PROPER TREATMENT OF MEN.

By A. SWARTZ.

Engineer Maintenance of Way, Toledo Railways and Light Co.

Money is "that which all men try to acquire," and I believe this is the main object with all track laborers, in fact with all classes of laborers. It is very hard for a foreman to hold trackmen on his gang when other roads crossing or paralleling his road are paying higher wages. There are a few foremen who by their striking personality can hold a gang together and get excellent results while paying less wages than other employers. There is on this road today a foreman, who has been six months in our service, who brought with him 15 men the first day. He was told to get 20 men and has kept his gang filled with Americans, except probably four or five foreigners. If it were necessary he could get 30 or 40 men, yet we are today paying somewhat less than other roads and 50 cents per day less than building and paving contractors. His success is due entirely to his pleasing personality, for his gang has worked harder than any other gang we have and has worked at least 20 nights in the past two months besides working each day. All of his methods are not yet known to me, but I do know that he treats his men like men and very seldom speaks roughly. We have another foreman who cannot increase his gang to ten men, and keep them more than two weeks, yet he does not work his men as hard as other foremen.

It has always been my policy to divide any overtime equally among all the men, as they can all use the money. During winter months I endeavor as far as consistent to keep six men on the payroll where we were allowed to work three men per section, working them all half time, and thus holding the men for the next year. This works very nicely on country sections and in villages or small towns. Of course some men will not remain, but where foremen have failed in this matter, the roadmaster has explained the situation to the men. I have myself on one or two occasions explained the matter after the others have failed, for we are all human and susceptible to a certain amount of flattery. To get best results an officer must have the respect and confidence of all his subordinates. One can get more work from a man he treats well than otherwise. On the other hand, such kindness is sometimes taken advantage of by the men.

I believe it is advisable to let the men take 50 minutes or less for noon hour and give them that much time on Saturday. Another matter which helps to keep men is the use of motor cars, for pumping a hand car from two to four miles is tiresome work, which discourages many a man long before he is thoroughly used to it. On one road I was with, the men were paid for ten hours, whereas they could only work 8½ or 9 hours during the winter. I am not sure that this is still being done, but I consider it a politic move. With this company an order was issued this summer that all employees in service one continuous year should have two weeks vacation with pay. We do not have a



great number of employees, but many of our best workers will endeavor to stay with us this winter. Of course this is costly under any circumstances, but I fully believe we will be repaid, and that the same thing perhaps to a lesser degree would be a paying investment on many railroads.

On another road our trackmen and other employees were encouraged to farm the right of way for small crops, with no charges for the land. There are many fine places with good soil on the right of way where it will save mowing weeds and fighting fires if the land is tilled. At my headquarters we had five acres of shop land which was expensive to keep clean and free of fires. We rented this to two employees for farming. This was in a small town and was a stroke of good fortune to these men. We always encouraged the men to take home old ties for firewood and allowed them to carry them in on hand or push cars when through working.

With foreign laborers the question is more complex, for they expect a great deal for nothing. The main thing is to provide them with good bunk cars that do not leak and are proof against cold winds; and I have spent many dollars to put good roofs on their cars and to line them with tar paper, which also acts as proof against vermin. They also want good, substantial stoves and need them early. The supervisor should have his bunk car stoves ready for distribution by September 1, for it gets very cool at nights by that time. We also used to appease the foreigners by being quite liberal with trip passes so they could visit their brothers and cousins. This same thing applies with native labor.

When a gang was lagging we used to lay out a good day's work and tell the men that when it was done well they could go home for the day. This acted as a great stimulant to the men and at the same time we got the benefit of a good day's work for quite a time until they began lagging again, when we would offer the same inducement. This is a matter to handle carefully, for all gangs are not alike.

Another matter often forgotten is to provide the men with a sufficient number of good tools. Nothing will disorganize a gang quicker than poor tools and not enough of them. If the tools are poor, the men must work harder to get the results. If there are not enough tools, some men feel that they are imposed on by being required to do the same class of work all the time because the other men have not the proper tools.

Summing up the matter in a few words, we should remember the Golden Rule, "Do unto others as you would have them do unto you." In other words, remember we are all of the same clay.

*(Other articles will appear in next Maintenance Section.)*

## MASTER PAINTERS' ASSOCIATION.

General announcement of the subjects to be considered at the tenth annual convention of the Maintenance of Way Master Painters' Association to be held at the Hotel Henry Watterson, Louisville, Ky., November 18-21, was made in our issue of September 19, page 531. The following additional information concerning the details of the program and papers to be presented is now available.

Advertising value of railroad painting, decorating and neatness of appearance, by Martin Kane, master painter, D. & H., Albany, N. Y.

Treatment of concrete surfaces, by George Whigelt, president of Inventor's League of the United States, New York City.

Workman's compensation legislation and the lessons it should teach the railway foreman painter, by Edward Hurst Brown, of the *Painter's Magazine*, New York City.

Difficulties and deficiencies in railway bridge painting, by William G. Wilson, secretary-treasurer, M. of W. Master Painters' Association.

Among the open questions for discussion will be the following:

Contracting of railroad painting, its advantages or disadvantages.

Painting of concrete and cement work.

Inside flat finishes.

How can we best take care of structures exposed to exhaust of engines, smoke, gases, etc.?

What is the most efficient way of painting the interior of steel water tanks, exposed to different kinds of water?

## A NEW 90-LB. RAIL SECTION.

The Denver & Rio Grande has designed a new 90-lb. rail section, which was rolled this year for the first time. This section is a compromise between the A. R. A. sections A and B, and was designed to meet the local requirements of stiffness combined with resistance to wear. Passing through the most mountainous portion of this country, the Denver & Rio Grande is very crooked, with many curves of 10 deg., and the curve wear of rail is therefore excessive. Likewise, the heavy Mallet locomotives introduced a year ago place very heavy wheel loads on

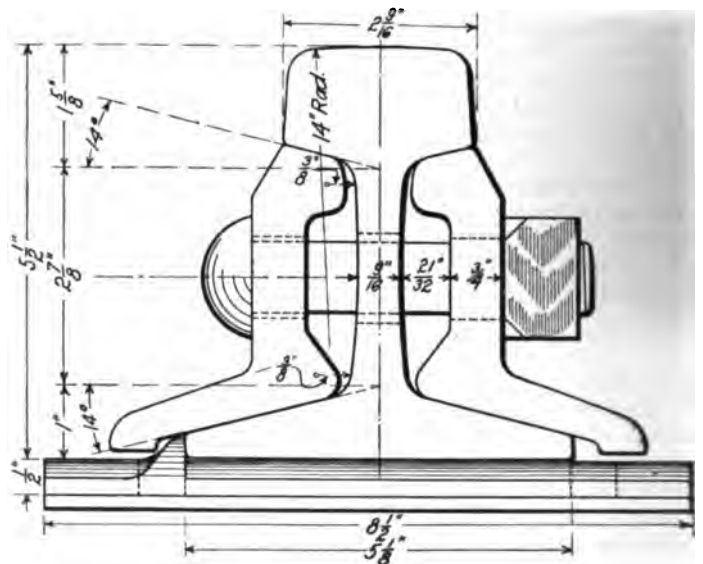

Section of D. & R. G. 90-lb. Rail with Angle Bars and Tie Plate.

the rail. This section has been designed to combine, as far as possible, the stiffness of the A. R. A. type A with the heavy head of the A. R. A. type B rail. The height is 5½ in. as compared with 5¼ in. of the A. R. A. type A section, and the area of the head 3.50 sq. in., as compared with 3.56 of the type B section.

The rail is supplied with four-hole 26-in. slotted splice bars projecting over the base of rail sufficiently to permit the use of a uniform shoulder tie plate for joint and intermediate ties. A section of the rail, angle bar and tie plate is shown in the accompanying drawing.

## A CORRECTION.

In the letter to the editor by J. M. Fair, in the issue of September 19, page 504, discussing methods for calculating frog angles, the word degrees was substituted for minutes, and minutes for seconds. As corrected the last two sentences should read: "These results will always lie between those secured by the sine and tangent methods, their differences from those calculated by Mr. Rizer with the sine formula being 2 min. 11 sec. for a No. 4 frog, 37 sec. for a No. 6, 15 sec. for a No. 8, 7 sec. for a No. 10, 1.5 sec. for a No. 15, and 0.3 sec. for a No. 20. Such errors as these can frequently be overlooked for the sake of a handy rule of thumb."

# BOSTON & MAINE YARD AT MECHANICVILLE.

Construction of Large Hump Yard with Complete Engine Terminal, Car Repair Facilities and L. C. L. Transfer Station.

The Boston & Maine has practically completed the construction of a new 4,000 car hump yard at Mechanicville, N. Y., to replace a flat yard which had a capacity of about 800 cars. This yard classifies the transfer business received from the Delaware & Hudson, amounting to about 250 cars a day during the summer months and about 800 cars a day in the early winter, this fluctuation being due to the increase in the movement of anthracite coal from eastern Pennsylvania which forms about half of the eastbound traffic transferred at this point. By building the new hump yard with a capacity considerably in excess of that required for this Delaware & Hudson business, it will be possible to abandon

utilizes the old tracks as far as possible, although it also includes an addition almost as large as the original yard and requires a complete rearrangement of the leads at both ends. The receiving yard is directly west of the classification yard, extending along the main lines of the Boston & Maine to Rotterdam Junction and the Delaware & Hudson to western and northern points. The engine terminal which includes all facilities for handling and repairing engines, is located on the south side of the classification yard near the east end, and the minor yards are grouped near the hump along the lad-



Temporary Hump in Operation.



New Engine House with Classification Yard in Background.

the classification yard now operated at Rotterdam Junction, 22 miles west of Mechanicville, where about 350 cars a day are received from the New York Central and the West Shore, and bring this business to Mechanicville. The new yard will allow the making up at this point of solid trains for Boston, Brattleboro, Springfield, Worcester, Lowell, Portland, Bangor and other eastern Boston and Maine points.

## ARRANGEMENT OF NEW YARD.

The new yard has been built at a cost of over \$1,000,000, and occupies a narrow strip of land about 2½ miles long extending west from the joint passenger station of the Delaware & Hudson and the Boston & Maine. The new classification yard occupies the site of the old flat yard and

ders leading to the classification yard. The buildings in these minor yards include the car shop alongside the repair yard, the icing station, stock pens and transfer platforms. The receiving yard has ten tracks with a capacity of 80 cars each, the classification yard has 35 tracks of 65 car length, the repair yard has eight tracks, the transfer yard seven tracks, the detention yard six tracks and the caboose yard three tracks.

Both main tracks are carried north of the yard, but this will not be an objectionable operating condition, as very few switching movements will have to be made over the main tracks on account of the fact that there is no westbound

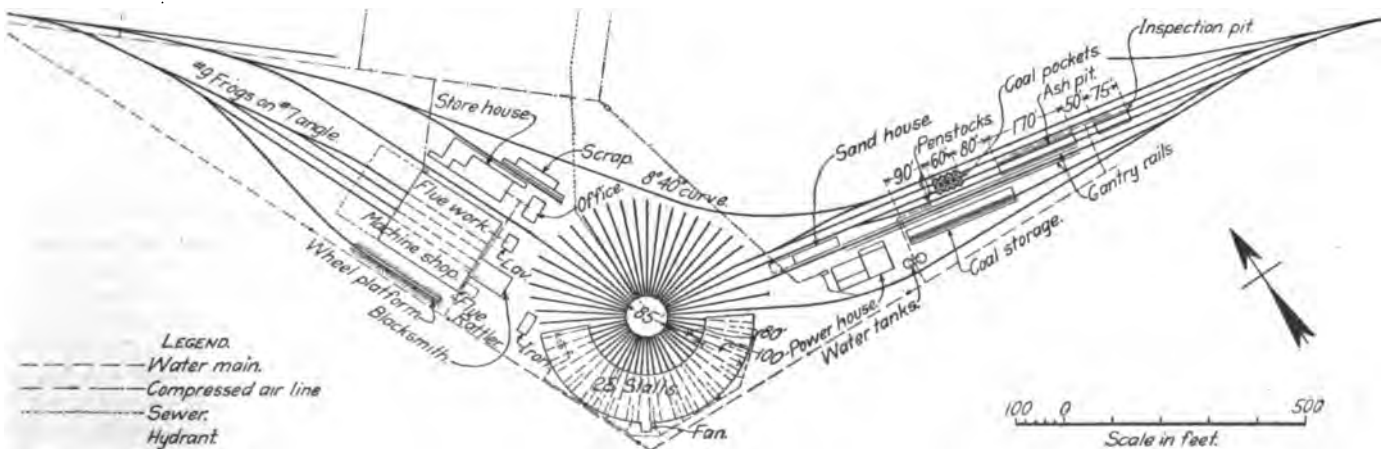

Plan of Engine Terminal at Mechanicville.

movement out of the yard. A Delaware & Hudson train bringing transfers from the north or west or a Boston & Maine train bringing transfers from Rotterdam Junction will pull into the receiving yard from the eastbound Boston & Maine main track. A Delaware & Hudson engine leaving a train in the receiving yard will take a running track north of the hump to the main tracks, which at that point are used jointly by the two roads, from which it can reach the new Delaware & Hudson engine terminal directly. A Boston & Maine engine after leaving its train will take a running track south of the hump and following along the south side of the classification yard will either enter the new engine house directly over the turntable or take a wye track and back into the house over the inspection and ash pits, taking water and coal if desired. A Boston & Maine engine taking a train eastbound leaves the engine house over one of four tracks, backs into the classification yard to get its train and pulls out directly onto the eastbound main.

Cars leaving the receiving yard pass over the hump and enter the classification yard from two ladders down the center of the yard, between which is laid a track for a motor car which will carry the riders back to the hump. Cars containing L. C. L. freight can be set alongside the transfer

the minor yards alongside the hump, the distance from the bottom of the accelerating grade to the first switch leading into the classification yard is almost 1,300 ft. This lead and about 1,500 ft. of the classification yard tracks are on a 0.5 per cent. grade, the remaining length of the yard being on a 0.244 per cent. grade.

CONSTRUCTION.

The yard site was formerly a large swamp with a ledge of rock along the west side. The fill required about 450,000 yds. of material, 325,000 yds. of which was secured from excavation in the rock ledge. This excavation was made by four type 70-C Bucyrus shovels with one standard gage and four narrow gage outfits, the maximum haul being about one mile. As the material is largely rock and gravel and is practically self-draining, very little provision for cross-drainage was necessary.

Near the west end of the receiving yard a single track electric line of the Hudson Valley Railway crosses the site, making it necessary to provide a bridge to carry this line over the new yard. Originally the electric line was laid practically on the ground at the site of the crossing and it was necessary to make a cut of about 65 ft. at this point to bring the yard down to the finished grade. During the excavation

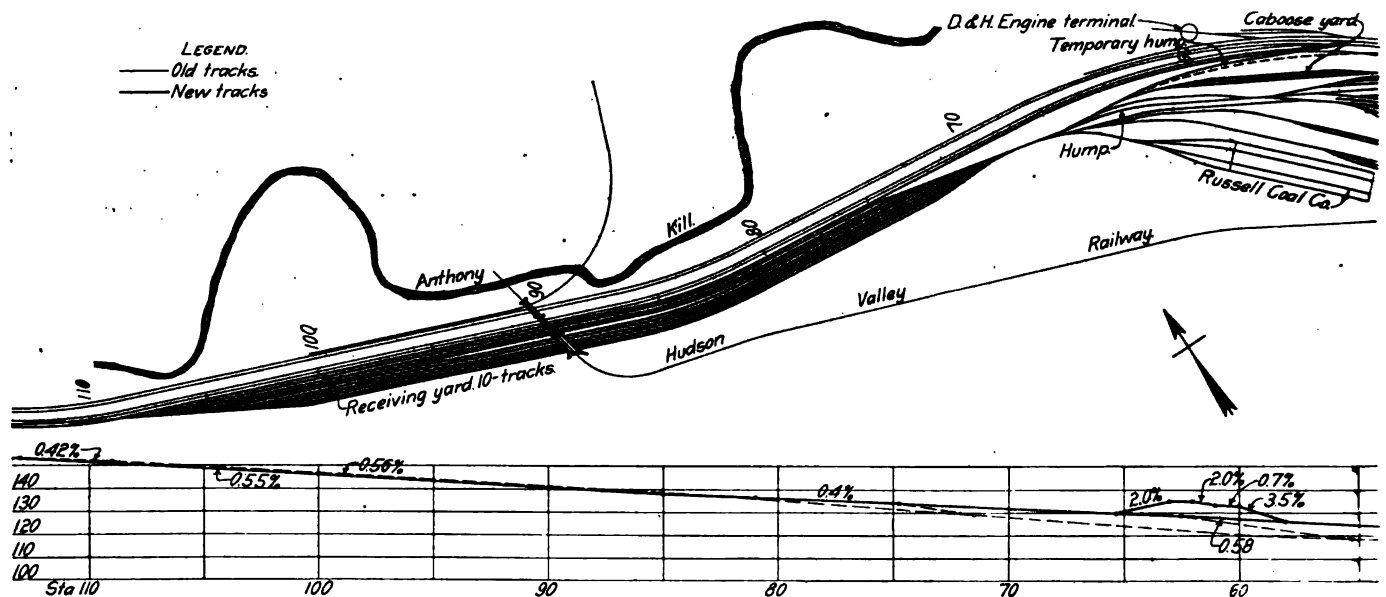

Layout of New Boston & Maine Hump Yard.

platforms over a track passing north of the hump and bad order, stock and refrigerator cars can be handled to the repair yard, stock pens and icing station, respectively, over leads passing south of the hump. The detention yard containing six short tracks off of one of the main ladders of the classification yard, is used to retain cars which through error pass over the hump without their destination being thoroughly understood between the rider and the switchmen, or cars held for definite billing. All such cars are shunted into this yard, from which a switch engine can again push them over the hump without switching one of the long classification tracks.

YARD GRADES.

The grade of all yard tracks is descending eastbound for the entire length of the terminal. The grade through the receiving yard varies from 0.55 per cent. to 0.4 and in the classification yard from 0.5 to 0.244. The approach to the hump rises on a two per cent. grade for 232 ft., but on account of the falling grade in the receiving yard a hump engine has no difficulty in pushing 80 cars over. The remaining grades on the hump are 100 ft. of level, 100 ft. of two per cent., 100 ft. of 0.7 per cent. over the scales and an accelerating grade of 3.5 per cent. 200 ft. long. On account of the location of

of this cut it was necessary to keep a temporary structure under the trolley track to allow the continuous operation of cars. The excavation directly under the track was made by hand and framed bents were placed at intervals close enough to carry the electric line traffic. The permanent bridge consists of two 106-ft. through girder spans carried on concrete piers. By arrangement with the electric railway company 48 hours was allowed in which to place each of these spans, but by careful preparation for the work, a maximum of 36 hours was required to tear out the old structure and place one of the new girders.

TEMPORARY OPERATION.

The new yard had to be built without interruption to traffic and on this account the receiving yard was built complete before the operation of the old flat yard was interrupted. After the completion of part of the new receiving yard a temporary track was laid from the east end of this yard to the west end of the old flat yard and the grade of this temporary track was raised to allow it to be operated as a hump. This temporary hump was in service for eight months before the completion of the new classification yard and the permanent hump, so that an excellent opportunity was given to study its operation under varying conditions, the hump profile

which was finally adopted being the result of this study. It was possible to use 15 of the classification tracks with the temporary hump and by employing 10 riders, the capacity of the old yard was increased to about 600 cars a day. As the approach to this temporary hump was on a curve making it difficult for an engineman to see signals given from the hump, two electrically operated signals were installed, one on the hump and one located some distance back on the approach track where it could be seen by an engineer handling a long train. These signals had two semaphores and were operated by electric switches from the hump. The following indications were adopted:

Upper blade, clear; lower, stop—"come slow."

Both blades, clear—"come fast."

Upper blade, stop; lower, clear—"back up."

The new yard is laid with 85 lb. second hand rail. Number 9 frogs are placed on No. 7 ladders and No. 10 frogs are used for turnouts from the main line. Gravel ballast was hauled about 14 miles and cedar ties were used except on leads and curves where hardwood was used. All tracks are spaced 13 ft. center to center.

ENGINE TERMINAL.

The engine house is a brick structure containing 25 stalls

to each pit. The pits are given a pitch of 6 in. toward both ends for drainage. A drop pit is provided under two stalls for light repairs, heavy repairs being made on the jacking pits in the locomotive shop.

The power house is a brick building 123 ft. by 50 ft., including a boiler room, engine room and heater room. The roof is carried on steel trusses which are framed to support a coal hopper the full length of the boiler room which feeds coal to the automatic stokers above the boilers. The ashes are conveyed to an ash pit 12 ft. wide and 10 ft. deep alongside the building which also extends the full length of the boiler room. A cross section of this building is shown in one of the accompanying cuts.

COALING FACILITIES.

The method of handling coal at this terminal is rather unusual. Coal is brought in in bottom or side dump cars which are run up on a concrete trestle supporting an inclined slab which chutes the coal when dumped into a shallow concrete pit from which it is removed by a clam shell operated by a gantry crane. This gantry crane is electrically operated from a third rail, the power being supplied by a generating plant in the power house. The gantry track extends alongside the coal trestle, the power house and the locomotive ash

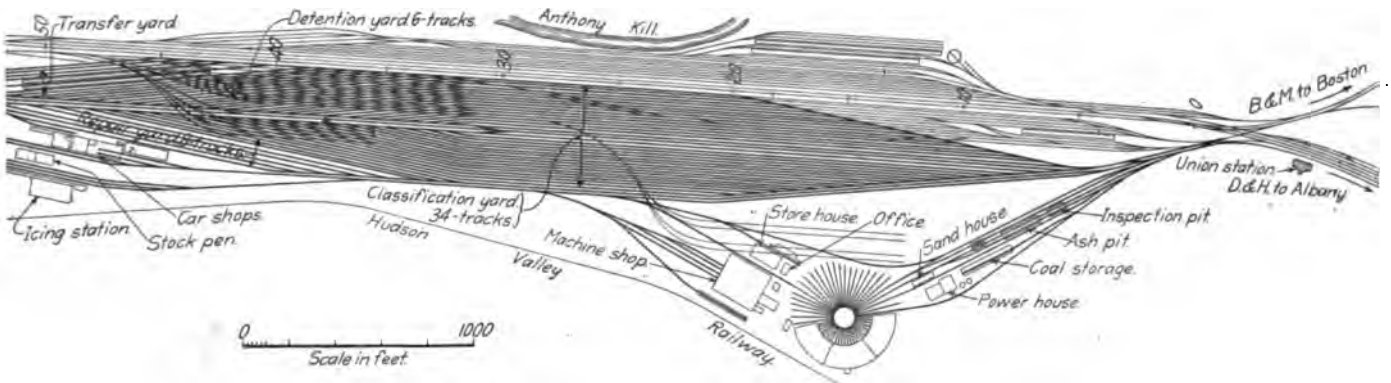

0.5%	Base of rail in new yard									130
0.3%	Base of rail E.B. main	0.23%		0.24%		0.62%				120
										110
										100
50		40	30	20	10	Sta 0				

Layout of New Boston & Maine Hump Yard (Continued).

in a 52-stall circle, and is divided by brick fire walls into three sections, two of which contain eight stalls and one nine. An 85 ft. turntable was installed and radial tracks for the full circle have been laid to provide additional storage room for locomotives. The turntable is provided with both air and electric tractors. The superstructure of the house is of frame construction with wooden smoke jacks and 5 ft. by 8 ft. monitors. The stalls are 100 ft. long and the track pits 75 ft. The walls of the pits are of concrete with 8 in. by 16 in. timbers under the rails and 12 in. by 12½ in. jacking timbers outside of the rail supports, all of which are anchored into the concrete walls by ¾ in. bolts at 6 ft. intervals attached to cast iron pockets set in the concrete just above the floor of the pit. The bolts are inserted in 1¼ in. gas pipe sleeves as shown in the accompanying cross section. The cast iron pockets are 4 in. square inside and open on the inner end to allow adjustments of these anchor bolts to be made. The jacking timbers are treated with two coats of preservative by a dipping process. The floor of the house is of concrete, 4 in. thick laid on a cinder fill. The building is heated by hot air brought in through a duct along the inside wall and 24 in. laterals between each pair of stalls, having three inlets

pits, so that in addition to handling coal to the coal pockets or in emergency to locomotives direct, the gantry removes the ashes from the locomotive ash pit and from the boiler house ash pit and supplies coal to the overhead bunkers above the boilers. A standard gage track between the gantry rails allows cars to be spotted under the gantry for receiving ashes.

The coal trestle is 348 ft. long and the storage pit 240 ft. The approach to this trestle is on a five per cent. grade, the 240 ft. section alongside the pit being level. The approach bents are solid concrete piers with a minimum thickness of 1 ft. 6 in. and varying in height from 11 ft. 1 in. to 13 ft. 9 in. A typical bent is shown in the accompanying drawing. The bents alongside the storage pit support a 10½ in. concrete slab inclined 35 deg. to the horizontal. The upper edge of this slab is supported by buttresses. The storage pocket varies in width from 9 ft. 7 in. to 12 ft. 9 in., the 6 in. slab which forms the floor of the pocket being given a slope of 2 ft. 3½ in. toward one end for drainage. The outer wall of the pocket is carried up a uniform distance of 4 ft. above this floor slab. The slab is laid on 12 to 14 in. of gravel, thoroughly tamped. Reinforcement is used only in the in-



municipal system in Mechanicville. About two miles of water pipe have been laid throughout the terminal for fire protection and service lines and three 50,000 gal. tanks are provided for storage. The locomotive and blacksmith shop located near the engine house is a steel frame structure with brick walls 170 ft. by 200 ft. Four tracks are provided

signed to handle this quantity easily. The platforms consist essentially of columns of cast iron pipe 4 in. in diameter with a 1/2 in. shell driven about 4 ft. into the ground and connected by a concrete wall 2 3/4 in. thick reinforced with wire cloth. The pipes on opposite sides of the platform are tied together by 5/8 in. tie rods. The space between these walls is filled with sand or gravel placed in layers not more than 6 in. thick, thoroughly puddled, on which is laid a 3 in. sand bed under the 2 in. concrete platform. This platform is given a pitch of 1/8 in. per ft. from the center toward both sides and is marked off in 2-ft. squares with all joints cut through the concrete and sanded or separated with tar paper. The platforms are covered by canopies of frame construction supported by a single row of concrete piers in the center of the platform.

The group of buildings alongside the repair yard includes a brick car inspectors' building and a frame storeroom and shop with the necessary platforms for handling the car material. The Howe scale on the hump is 54 ft. long, the approach track being carried directly on concrete walls to decrease the shock to cars passing on to the scale.

The yard is lighted throughout by electricity generated at the power house. A complete telephone and electric bell system is installed for communication between all points in the yard. About two miles of pipe have been laid for carrying compressed air to various points in the yard and four septic tanks have been built to handle the sewage.

The construction of this yard was handled under the supervision of A. B. Corthell chief engineer, Boston & Maine, and F. C. Shepherd, engineer of construction. G. H. Cove was resident engineer in direct charge of the work. The Wilson & English Construction Co., New York, had the general contract for grading the yard, laying the tracks and placing the foundations for the buildings. The H. P. Cummings Construction Company, Ware, Mass., built the engine house and installed the water pipe lines. The H. Wales Lines Company, Meriden, Conn., and the Nial Brothers Construction Company, Troy, N. Y., had contracts for various buildings in the locomotive and car repair groups. We are indebted to the engineering department of the Boston & Maine for the above information.



Laying the Firebrick Lining in the Ash Pit.

through the two central bays of this shop and jack pits and all necessary machinery are included in the equipment for making heavy repairs to locomotives.

In addition to the facilities described the engine terminal includes a storehouse, scrap bins, wheel platforms, bar iron rack, sand house, office and lavatory. The latter building

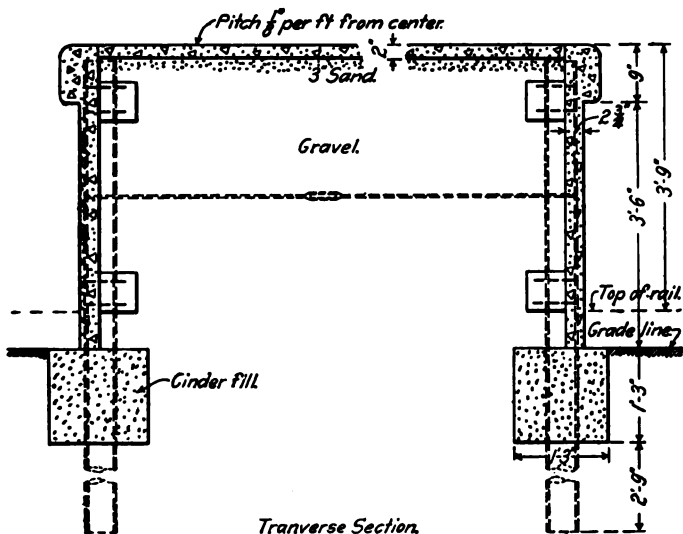
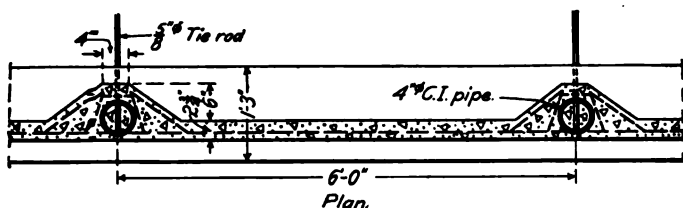

Detail of Transfer Platform.

provides all facilities for the comfort of the men, including shower baths and recreation rooms.

The two transfer platforms located near the hump are of concrete construction. Each platform is 800 ft. long and 15 ft. 3 1/2 in. wide. About 60 carloads of L. C. L. freight are transferred daily at this point and these platforms are de-

### ABSTRACT OF ENGINEERING ARTICLES SINCE SEPTEMBER 19.

The following articles of special interest to engineers and maintenance of way men, and to which readers of this section may wish to refer, have appeared in the *Railway Age Gazette* since September 19, 1913:

**Adopted Design of the Quebec Bridge.**—The changes that have been made in the design of the Quebec bridge by the Board of Engineers appointed by the Canadian government to take charge of the reconstruction of that bridge, were published in the issue of September 26, page 559, as abstracted from a paper by Ralph Modjeski, member of the board. The article includes a very comprehensive discussion of the various features of design that are taken into account in a structure of this size.

**New Western Pacific Shops at Sacramento, Cal.**—An illustrated description of the complete new shop installation of the Western Pacific at Sacramento, Cal., was published in the issue of September 26, page 564.

**Double Deck Bascule Bridge.**—The design of the first double deck bascule bridge of the Strauss type which was recently completed over the Kaministiquia river at Fort William, Ont., for the Canadian Pacific, was published in the issue of October 3, page 603. The article includes illustrations of the bridge and details of construction.

**Construction of the Buckhannon & Northern Railroad.**—The construction of a new line into the West Virginia coal fields was described in the issue of October 3, page 617. This line is owned jointly by the Baltimore & Ohio, Pittsburgh & Lake Erie and Pennsylvania. The most unusual features of the construction work were the methods used to overcome the serious slides which were encountered. An editorial note commenting on this work was published on page 598 of the same issue.

**Analysis of a Broken Rail.**—An abstract of the report of the Interstate Commerce Commission on the broken rail which derailed train No. 7 on the Louisville & Nashville, October 1, 1912, was published in the issue of October 3, page 623. The report comments at length on the formation of

interior transverse fissures which were apparently the cause of the break.

**Canadian Northern Montreal Terminal.**—The peculiar conditions which required the expenditure of \$20,000,000 for the Canadian Northern to gain an entrance to Montreal and the interesting features of construction in building the 3¼ mile tunnel under Mt. Royal, were described and illustrated in the issue of October 10, page 651. An editorial commenting on this work was published in the same issue, page 640.

**Features of the Kalka-Simla Railway.**—An article by Lewis R. Freeman, in the issue of October 10, page 657, contains an interesting description of the railway which has the highest average cost per mile of any road in India. It is 60 miles long and has a 2 ft. 6 in. gage. The high cost was due to the necessity for very extensive protective work over the loose shale formation on which the line is built.

**Boston & Maine Extension from Hinsdale, N. H., to Brattleboro, Vt.**—The construction of a seven mile line to give the Boston & Maine an entrance to Brattleboro from the south over its own rails, was described in the issue of October 10, page 661. The most unusual features of the work were the handling of a quicksand cut and the building of a two span truss bridge on a four degree reverse curve.

**Renewing Two Double Track Swing Spans.**—The Central Railroad of New Jersey has just completed the reconstruction of 2¼ miles of line across the Hackensack Meadows which was undertaken in order to replace the two swing bridges over the Hackensack and Passaic rivers. The method of moving the old draw spans to a temporary location by floating on scows, and other details of the construction work, were given in an article in the issue of October 17, page 699.

**B. & O. Engine Terminal at Cumberland, Md.**—The Baltimore & Ohio has recently completed a division engine terminal at Cumberland, Md., which was especially designed for handling large Mallet locomotives. A description of this layout and the structures in connection with the terminal was published in the issue of October 17, page 709.

## PENNSYLVANIA TRACK MAINTENANCE PRIZES.

The Pennsylvania Railroad has just awarded \$5,400 in premiums to supervisors and assistant supervisors who have maintained their sections in the best condition during the past year. The award was made by S. C. Long, general manager, on October 14, after the annual inspection trip which was participated in by 300 operating officers of the Pennsylvania system.

The awards were made upon the basis of monthly inspections by a special committee composed of L. R. Zollinger, engineer of maintenance of way, chairman; Elisha Lee, assistant to general manager; A. B. Clark, assistant engineer of maintenance of way, roadway and track; C. S. Krick, superintendent, Manhattan division, and J. J. Rhoads, superintendent of the Central division. The largest premium, \$1,200, of which \$800 goes to the supervisor, and \$400 to the assistant supervisor, who have made the best showing on the main line between New York and Pittsburgh, and Philadelphia and Washington, was awarded to C. M. Wisman, supervisor, and H. M. Grimm, assistant supervisor, in charge of the territory between Tullytown, Pa., and Deans, N. J.

The other prizes were as follows: Four premiums of \$800 each, \$600 for the supervisor and \$200 for the assistant supervisor for the best line and surface on the main line superintendent's division between New York and Pittsburgh, and Philadelphia and Washington; Elmer Irving, supervisor, and W. E. Dunbar, assistant supervisor, in charge of track between Dillerville, Pa., and Coatesville; J. A. Burchenal, supervisor, and N. A. Camera, assistant supervisor, in charge of track from Anderson, Pa., to Thompsettown; George Ehrenfeld, supervisor, and R. S. Stewart, assistant supervisor, in charge of track between Altoona, Pa., and Portage, including the "Horse Shoe Curve"; G. B. H. English, supervisor, and C. M. Hursh, assistant supervisor, in charge of track between Wilmington, Del., and Perryville, Md. A special improvement premium of \$1,000; \$700 to the supervisor and \$300 to the assistant, for the greatest improvement made in line and surface on the main line between New York and Pittsburgh, and Philadelphia and Washington, was awarded to Supervisor C. Z. Moore and Assistant Supervisor C. L. P. Russel, who have charge of the track between Dillerville, Pa., and Harrisburg.

**CYPRUS RAILWAY.**—The Cyprus Railway, which has a narrow gage of 2 ft. 6 in., is owned by the government, there being 61 miles of line in operation in 1911.

## EFFECT OF TREATED TIES ON TRACK CIRCUITS.

The difficulties experienced in successfully operating track circuits for automatic signals when zinc treated ties are in use were brought out in a committee report presented to the convention of the Railway Signal Association at Nashville on October 14. The report was based on replies received from 126 members, and showed in brief that track circuits a mile long are rendered inoperative by the extensive use of zinc treated ties; that track circuits 2,000 ft. long may be successfully operated with 50 per cent. or more of the ties so treated; that renewals amounting to 10 to 15 per cent. of the total number of ties will not materially affect the operation of such track circuits; that where such renewals are made in continuous stretches the leakage is much greater than where they are made singly at uniform distances; that while surface salts are present more leakage occurs during wet weather than with untreated ties; that in dry hot weather the salts are drawn to the surface and constitute a more or less perfect conductor; and finally, that after a period varying from three months to a year these salts disappear and subsequently no interference is noticeable. In the discussion which followed the presentation of the report, the opinion was expressed that the power necessary for operating the track circuit may be increased as much as one-third by the use of creosoted ties. Cases were cited where track circuits 6,000 ft. long had been successfully operated with three-fourths of the ties creosoted, and also when a combination of zinc chloride ties and creosoted ties had been used.

## A GASOLENE ROCK DRILL.

A new type of rock drill has recently been brought out which is operated by gasoline rather than air or steam. This is an entirely self-contained unit consisting only of the drill and tripod and requires no other equipment. The drill has a full floating, free piston action. The piston rod, pistons and bit are all connected together, forming a direct striking piece, acting and striking the rock in the same manner as the air and steam drills. Little difference in appearance can be noted between this drill and the standard air or steam drills, except the absence of the usual auxiliary equipment of steam boilers, air compressors and piping.

The motive force of this gasoline drill is furnished by two

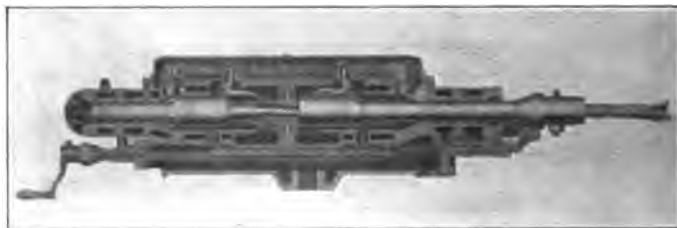

Section of Drill Showing Interior Arrangement.

cylinders opposed to each other. A piston rod is fitted with a piston for each cylinder, on the end of which is the bit chuck, continuing through the two cylinders. A make and break spark plug for each cylinder is tripped and fired by each piston alternately. The firing of the rear cylinder drives the piston and bit forward, hitting the rock directly with all of the force of an explosion of gasoline. The front cylinder then fires and the piston is sent back to its first position with the full force of an explosion, lifting the bit with extraordinary power. This operation continues indefinitely.

The pulsator is of the two cycle design without valves and is fired at each stroke of the piston. The cylinders are water cooled under the control of a self-contained pump operating simultaneously with the drill. The fuel and oil container is

attached to the side of the drill and is adjustable with respect to the angle at which the drill is set. When running, the lubrication of the working parts is automatic. The oil is fed into the gasolene, and the cylinders, pistons and bearings receive the necessary amount.

The drill strikes 600 blows a minute with a bit 24 ft. long and drills a hole from 1 1/8 in. to 2 3/4 in. in diameter at any angle. The cutting speed is under the control of the operator, but when running at full speed the drilling is said to be as rapid as with the air or steam drills of equal cylinder size and weight. It is stated that it operates for 10 hours on less than three gallons of gasolene when drilling continuously at the highest speed. The cost of daily operation is estimated



Drill Set Up Ready for Use.

at \$3.50 for drill runner, \$2.50 for drill helper, \$0.75 for gasolene, and \$0.10 for lubrication, a total of \$6.85.

This drill has been operated many times for runs of 10 or 12 hours per day, working several days consecutively. It has also been employed in actual work even in zero weather. At Greystone, N. Y., one of these drills worked continuously each day for six months with only minor repairs, and was exposed to severe winds and storms. It drilled into brown stone and blue flint rock, cutting 2 3/4-in. holes at the rate of 28 in. in 12 minutes, the holes averaging from 7 to 10 ft. in depth. It was developed and patented by John V. Rice, Jr., and is now made by the Rice Gasoline Rock Drill Co. of Philadelphia and Elizabeth, N. J.

### AN ANGLE IRON CLIP IN PLACE OF DRIFT BOLTS TO CONNECT BRIDGE STRINGERS TO THE CAP.

The Northern Pacific has made standard the use of angle irons with bolts and nuts to replace the drift bolts commonly used in fastening timber bridge stringers to caps. These angles are 15 in. long with 6 in. and 3 1/2 in. legs and are of 1/2 in. steel. The long leg is laid vertically against the stringer, as shown in the drawing, with two bolts extending

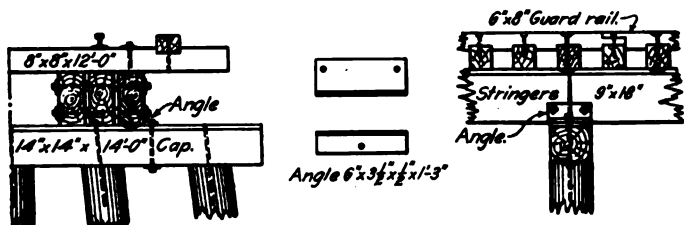

Details of Standard Trestle Construction on Northern Pacific Showing Use of Angle Iron.

through the timber and packing blocks. One bolt extends through the cap. This form of connection has been found to greatly facilitate the lining and shimming of stringers without injury to the fibre of the wood and also permits packing the stringers in a direct line without reducing the bearing area between the stringer and the cap.

### THE TRIPLELOCK SWITCH MACHINE.

The Triplelock switch machine, one type of which is shown in the accompanying illustration, is designed particularly for the operation and protection of main line facing point switches. It is generally employed at points where train movements are protected by signals, but can be installed with equal advantage without signals. It is designed to control any type of mechanical or power signal, and to operate a single switch or crossover or a switch and one or two derrails. It is so arranged that it is impossible to insert the padlock to lock the machine unless all the levers are in their normal position.

Where a signal is controlled by this machine it must be placed in the stop position before the switch can be unlocked and thrown. The method of locking the switch is similar to that used in mechanical interlocking. As arranged, it insures that the switch points are tight against the stock rail and in their correct position to correspond with the position of the switch lever. This is accomplished by means of two plungers,

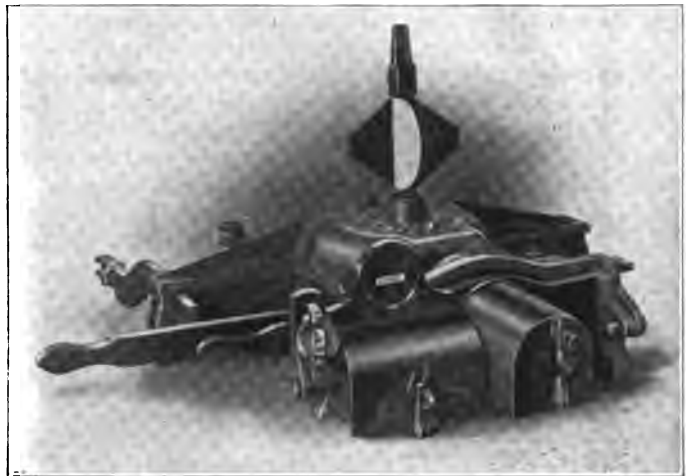

Triple Lock Switch Machine.

one for each position of the switch, the plungers entering holes located in different planes of the lock rod.

The machine shown in the accompanying illustration is equipped with a circuit controller and electric lock, the former being used to control the signal, permitting movements over the switch, and the latter to electrically lock the machine so that the levers cannot be moved except when conditions are right for their operation. This particular type of electric lock also gives a visual indication which shows "released" or "locked" in the face of the machine, indicating whether it may or may not be operated. The majority of these machines now in service, however, are equipped with electric circuit controllers only.

These machines have now been in successful service up to 3 1/2 years on several prominent eastern roads. A considerable number have been in use on the main line of the Erie for varying periods ranging up to two years, and at least 60 per cent. of the machines in service on this road have passed through two winters. Among other roads, they are also used extensively on the Atlantic Coast Line. These machines are manufactured by the Signal Accessories Co., 30 Church street, New York.



## MOVING A STEAM SHOVEL WITH TRACTION ENGINES.

A modern and unusual way of moving a steam shovel across country adopted by the Siems-Carey Company, of Plentywood, Mont., was recently described in the *Excavating Engineer*. A 70-C Bucyrus shovel was moved across country from Plentywood, Mont., on the Great Northern to the Ambrose extension of the



Steam Shovel Mounted on Trucks Ready for Moving.

Soo, a distance of 24.2 miles, in eight days. To accomplish this the shovel was mounted on ordinary house moving trucks attached to the shovel by means of false bolsters. A 32 h. p. Minneapolis and a 25 h. p. Case traction engine pulled the shovel. They were assisted in starting the load on hills by a 37 h. p. Saurer auto truck. In condition to be moved the shovel weighed about 52 tons. It is stated that no difficulty was ex-



Moving a Steam Shovel Across Country.

perienced in moving the shovel in this manner, and the trip was made at a much lower expense than would have resulted from the adoption of any other method.

## TRIANGULAR TIES ON THE GREAT NORTHERN.

A triangular tie of the dimensions shown in the accompanying sketch has been used in large quantities in the main track of the Great Northern since 1901. From 150,000 to 200,000 of these

ties are inserted annually and there are now about 2,000,000 triangular ties in the track.

In their manufacture either two or four ties are cut from a log, timber cutting four ties being preferred, as the annular rings of such ties are convex and provide better drainage. After a log is squared it is cut diagonally into either two or four pieces 16 in. long on one side and 8 in. in depth. Triangular pieces 2

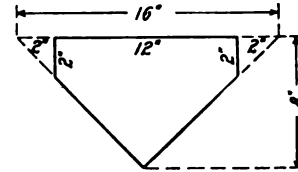

Cross-Section of Triangular Tie.

in. x 2 in. in size are cut from each of the two upper corners, leaving the face of the tie 12 in. wide. The ties are 8 ft. long. They are treated with a 6 per cent. solution of zinc chloride, equivalent to an injection of  $\frac{3}{4}$  lb. of zinc chloride per cubic foot of timber.

One advantage of this type of tie is its property of being more or less self-tamping, especially at the rail ends, and it has been found to reduce somewhat the expense of joint maintenance in gravel ballast. When not used in conjunction with the ordinary rectangular ties, the triangular tie is believed to give promising results, as some of the best track is carried on these ties.

## SHIFTING A LONG SECTION OF TRACK.

When a run-around track is needed along the edge of the right of way to make room for improvement work, there is very often a question as to the relative advisability of laying a new track without disturbing the old or of shifting the old into the

temporary position. When it is impossible to handle traffic over any other track during the time required for moving, it is of course necessary to adopt the first method, but on multiple track lines where by co-operation with the operating department, one track may be released for a short time, the fixed charge for the rail necessary to lay the temporary track may be avoided by moving over the old one.

In preparing for track elevation work recently on one of the western roads, this problem was met on a three track line and by exercising care in handling trains it was found possible to take care of the traffic on two tracks for a short period while

moving the third one. This line handles over 250 trains per day making it essential that the third track be kept out of service as short a time as possible. All arrangements for quick handling were therefore made before cutting the track and every effort was made to push the work of moving and connecting it up again.

The section to be moved was about ¼ mile long and the maximum throw was 70 ft. The rails on this section were fastened with screw spikes, and in order to make it easy to loosen the rails after the track was cut, all of these screw spikes were removed a day ahead of the shift and enough cut spikes driven to hold the rail in place under traffic operated at moderate speed. The ties for the temporary track were all laid in their proper

moving the last track from the time traffic was taken off until the rails were lined in their new position. From five to seven hours were required before spiking, lining and surfacing had been completed so that trains could again be turned over the track.

### A CONCRETE WATER TROUGH.

Although a watering trough for stock at stockyards is one of the less important details of maintenance of way work, it is nevertheless often an annoying one and the aggregate expense of construction and the maintenance of these troughs may be large.

This subject has received careful attention on the Salt Lake division of the San Pedro, Los Angeles & Salt Lake, and as a result a concrete trough has been designed which has withstood the severe climatic conditions on that line for three summers and two winters. Owing to the arid country through which this line passes, wooden troughs shrink and the seams open up in dry weather, unless kept filled with water, while in winter they freeze and burst. For these reasons wooden troughs require frequent attention and repairs.

The concrete trough illustrated herewith is 15 ft. long by 18 in. wide and 16 in. deep, inside dimensions, although the height can be varied as desired without any change in the forms, depending upon whether the trough is intended for sheep or cattle. The forms are collapsible, and if properly cleaned and painted after using, will last a long time. A set of these forms costs about \$30, and the troughs cost about \$12, or practically the same as properly constructed wooden troughs of the same size.

The top edges of the trough are rounded off with an ordinary sidewalk edging tool and all surfaces except the outside bottom are rubbed smooth with a plastering trowel as soon as the forms are removed. A drain plug is placed in one end. A trough requires 1 cu. yd. of 1:2:4 concrete, and 191 ft. of ¼ in. round steel for reinforcement.

Some of these troughs have been filled with water and allowed to freeze solid with the temperature about 15 deg. below zero. Although the expansive force thus created was great, the troughs were not injured in any way, as the ice crushed along the center of the trough. We are indebted to R. K. Brown, division engineer maintenance of way, for the above information.



Preparations Completed for Lining Over Long Sections of Track.

location and lined and surfaced. The engineering corps furnished grade stakes at 50 ft. intervals on the center line of the temporary track for use in the final lining of the rails. Skids of old ties were laid about 15 ft. apart from the old track to the new location. From 250 to 300 men were used in lining the track over, the number varying from day to day, as only one track could be moved each day. Only one cut was made in the old track approximately at the center of the section. By stirring up considerable rivalry among the Italian gangs engaged on this work, the time was cut down until only 50 min. was required in

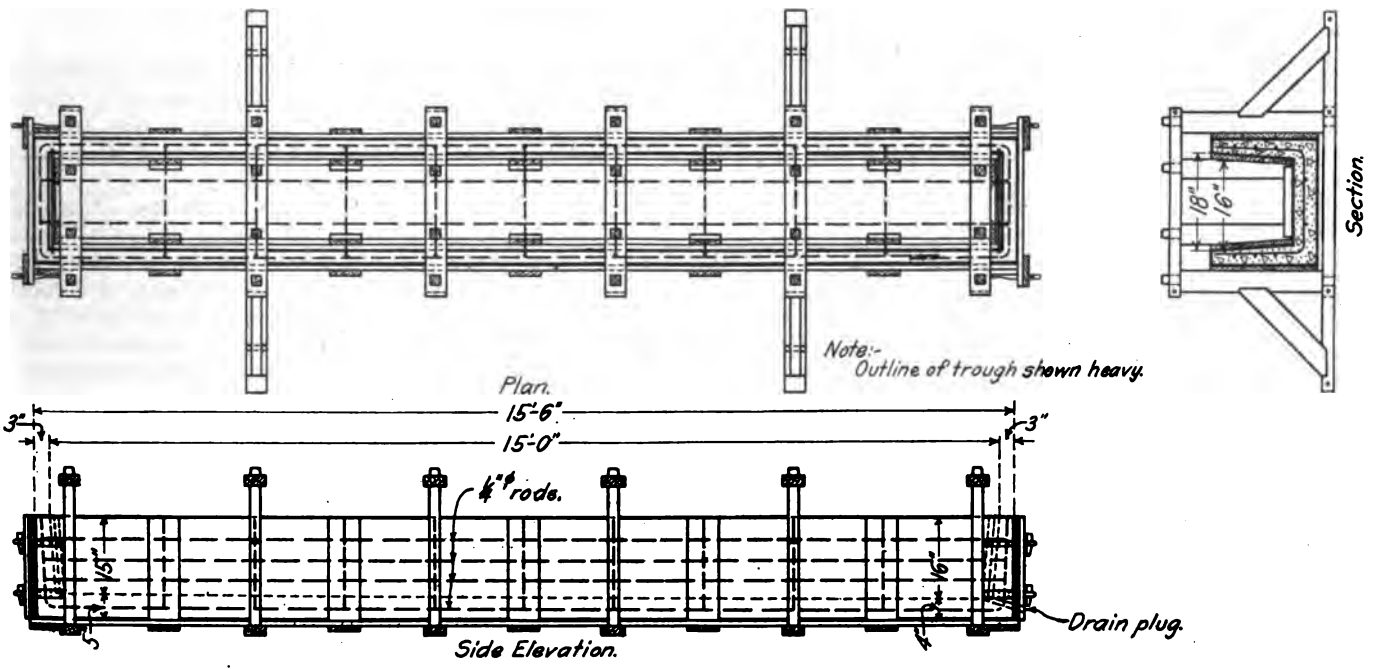

Concrete Stock Watering Trough and Forms.

# BRIDGE AND BUILDING ASSOCIATION MEETING.

Abstracts of Reports of Committees and Discussions at  
Twenty-Third Annual Convention Held This Week at Montreal.

The twenty-third annual convention of the American Railway Bridge and Building Association was held at the Windsor hotel, Montreal, on Tuesday, Wednesday and Thursday of this week. Over 100 members were in attendance at the opening session, and a number came in on the following days. The officers for the past year were: President, A. E. Killam, Moncton, N. B.; first vice-president, J. N. Penwell, L. E. & W., Tipton, Ind.; second vice-president, L. D. Hadwen, C. M. & St. P., Chicago; third vice-president, T. J. Fullem, inspector, Illinois Central, Memphis; fourth vice-president, G. Aldrich, N. Y. N. H. & H., Boston, Mass.; secretary, C. A. Lichty, C. & N. W., Chicago; treasurer, J. P. Canty, supervisor of bridges and buildings, B. & M., Fitchburg, Mass.

President Killam called the convention to order at 10 o'clock Tuesday morning and introduced Rev. Bruce Taylor, who offered prayer. The association was welcomed to Montreal by Wm. McNabb, principal assistant engineer of the Grand Trunk, in behalf of the citizens of Montreal and the railway systems with headquarters there. After referring to the attractions about the city he called the attention of the members in an interesting manner to the two prominent bridges of the Grand Trunk and the Canadian Pacific at this point, which are unusual not only for their size, but also because of the unusual difficulties attending their erection. He emphasized the importance of the two distinct functions of the association's work—the technical and the social. Mr. McNabb also fittingly referred to the disregard of national boundaries in the work of the association and urged a friendly rivalry between the railway men of the United States and Canada in the development of railway service as helpful to both countries.

B. F. Pickering, general foreman of bridges and buildings of the Boston & Maine, replied to Mr. McNabb, and in commenting on the development of the railways, called attention to the part this association had assumed in this work.

O. J. Travis, the founder and first president of the association, was present and spoke briefly.

In his address President Killam stated that a man never realizes how little he knows until he finds out how much his neighbor knows. The convention affords an opportunity for a free exchange of ideas. The importance of the work of this association was illustrated by Mr. Killam with the statement that the good design of structures may be entirely overcome if they are not properly maintained by skilled men. He also referred to the death of four members during the past year.

The report of the secretary showed a deficit for the past year of \$78. The treasurer's report showed a balance of \$1,412 in the treasury. Fifty new members have been admitted during the past year.

## WATER SUPPLY.

The amount of water consumed by our railroads is almost beyond comprehension and can be better understood by presenting comparative figures. In considering the consumption of water on a railway system of 6,500 miles of road it was found that 16,500,000,000 gal. was used annually. Assuming the same average consumption on the 248,888 miles of railroad in the country there is consumed annually something like 632,076,789,000 gal. of water. The question of railway water supply covers such a wide field that to discuss the subject in an intelligent manner the various phases must be taken up in regular order, beginning with the methods of pumping and the various types of pumping machinery, with an analysis of results obtained in actual practice.

The sources of railway water supply may be divided into the following general classes: Lakes or reservoirs, creeks or rivers,

wells and springs. It of course follows that different methods must be followed in the selection of pumping facilities, depending largely upon the source of supply. The location with regard to fuel supply will also have an important bearing on the type of plant to be installed. If it is desired to operate a pumping plant in connection with existing facilities it will be necessary to conform to the power already used at the plant in question.

While fuel consumption is the most important factor in pumping efficiency, it often represents only a small part of the cost of operation. In many instances attendance and interest and depreciation charges make up the greater part of the operating expense, and should be given consideration in the selection of a power plant. The figures given on the costs of pumping include only the fuel or power costs, as the other items of expense will be influenced largely by local conditions.

The development of the internal combustion engine to operate on the heavier low grade oils is necessary on account of the increased cost of gasoline. Various reasons have been given for the great increase in the cost of gasoline, the real reason being the direct action of the law of supply and demand. The percentage of gasoline in the petroleum produced each year is growing less and less, for the reason that the fields producing petroleum carrying a large percentage of gasoline are becoming depleted, while the California, Mexico, Texas, Oklahoma and other fields although increasing in production carry a much smaller percentage of gasoline-naphtha. At the same time there has been a great increase in the number of gasoline-propelled vehicles and gasoline engines for other power purposes.

The report then discussed the design and operation of internal combustion engines and presented results of tests on different fuels for combustion engines which showed a material economy for distillate over gasoline. This information is essentially the same as that published in the *Railway Age Gazette* of August 15, page 289.

There are few instances where electricity will prove economical as a method of pumping, except where the attendance charge may be eliminated or reduced to the minimum. Where current is purchased from a steam driven electric station the power company will of course expect a profit over the cost of producing the current and overhead expense which is considerable, and it will be difficult to show a saving over a properly installed steam plant.

As many of the new mechanical facilities which are being installed are equipped with electric power plants, it is possible that an electrical pumping station in connection with the same will furnish water at a low cost, but where current is purchased a very low rate is required to show economy.

It has been difficult to secure figures on the cost of pumping with electricity owing to the limited number of installations in service. Results are given of a test covering a period of 30 days of eight deep well units, each unit consisting of a double acting deep well pump head connected to a 5¼ in. x 15 in. cylinder driven by a 10 h. p. alternating current electric motor delivering water against 160 ft. head. No change was made in the usual method of operating the pumps, the test simply consisting of keeping a record of the performance. The tabulated results follow:

Total number of unit hours run.....	3,255
Maximum available running time in unit hours.....	5,400
Per cent. of maximum available time pumps were run.....	60.27
Speed of pumps .....	36 r. p. m.
Total gallons pumped .....	14,322,000
Pump efficiency, per cent.....	60.4
Gallons pumped per unit minute.....	73
Water horse power .....	2.94 d
Cost of current per k. w. h.....	.02c
Cost per water horse power hour.....	.03.2 to
Cost per 1,000 gallons .....	.02.4 mile

The following figures on pumping with electric power are taken from the proceedings of 1911 giving results as obtained with a 25 h. p. motor driving an 8 in. x 10 in. double acting triplex pump.

Total head in feet.....	49
Gallons per minute.....	611
Water horse power.....	7.6
Cost of current per k. w. h.....	.04
Cost per h. p. h.....	.042

The rate for current in the first table given above is very low and could only be secured where a large amount is consumed, while the rate of four cents would more likely represent the average rate and even at this rate the power company would probably require a contract based upon a minimum amount or a readiness to serve charge.

Steam is most commonly used in pumping water and is economical or otherwise according to the installation and location with regard to fuel supply. In localities where coal is plentiful and a long haul is unnecessary, and where a low grade of coal, such as raw screenings can be secured (aside from the question of attendance) water may be pumped by steam almost as economically as by any other power and generally with a great deal more reliability and lower cost of upkeep. This is especially true of a station where a large amount of water is used.

Few railroads have paid sufficient attention to the type of steam plant installed at water stations, having little regard for the steam consumption of the pump and installing any available boiler found unfit for any other service. Consequently the results obtained from many steam plants have not been as economical as they should be, for economical results cannot be secured from the use of obsolete and inefficient equipment.

The boiler is the most important consideration in a steam pumping station, as a saving of from 25 to 40 per cent. in fuel and repairs may often be effected by the installation of the proper type of boiler. The majority of pumping boilers are of the vertical type with anywhere from 1 to 150 tubes. This type is anything but economical either in fuel consumption or repairs, the only argument in favor of it being that it occupies little space, and is easily moved.

Where a water station is known to be permanent a horizontal return tubular boiler is the proper boiler to install. A boiler of this type will cost about 100 per cent. more to install than one of the vertical type, but many of the boiler troubles will be eliminated and the saving effected will justify the additional expenditure.

The following table gives some comparative figures on the cost of pumping with a vertical boiler, return tubular boiler, and a fuel oil pumping unit:

Kind of power.....	Steam		Fuel oil Combined	Steam	
	Duplex	Vertical		Duplex	Return tubular
Type of pump.....	14 in. x 8 1/2 in. x 10 in.	10 in. x 12 in.	14 in. x 8 1/2 in. x 10 in.	14 in. x 8 1/2 in. x 10 in.	
Size of boiler.....	60 in. x 132 in.	.....	.....	54 in. x 156 in.	
Head in feet.....	150	140	140	140	
Gallons pumped.....	34,000	74,000	34,000	34,000	
Gallons per minute...	283	412	283	283	
Fuel used.....	800 lbs.	7 1/2 gals.	360 lbs.	360 lbs.	
Cost per 1,000 gals...	.0235	.0106	.0108	.0108	
Cost per h. p. h.....	.038	.018	.0183	.0183	

The above figures were received in reply to inquiries sent out to various roads for data on the cost of pumping, and are typical of results obtained from vertical boilers as compared with horizontal return tubular boilers. It will be seen that the cost of pumping with steam using a return tubular boiler is practically the same as with fuel oil in this particular instance and less than one-half the cost of pumping with a vertical boiler.

	Fire Box Boiler	Return Tubular Boiler
Size of boiler.....	75 h. p.	100 h. p.
Time of test.....	10 hours	10 hours
Coal used.....	4,450 lbs.	3,210 lbs.
Feed water used.....	2,305 gals.	2,167 gals.
Feed water per lb. coal.....	4.3 lbs.	5.5 lbs.
Gallons water pumped.....	250,980	263,167
Gallons per minute.....	418	438
Coal used per 1,000 gals.....	17.7 lbs.	12.2 lbs.
Total head in feet.....	208	208
Cost of coal.....	\$2.22	\$1.60
Cost for coal per 1,000 gals.....	.0088	.0061
Cost for coal per h. p. h.....	.01	.007

The pumps used in the above test were two 14 in. x 18 in. x 20 in. x 12 in. duplex compound pumps, and the boilers were an old locomotive boiler and a walled-in return tubular boiler. The return tubular boiler shows a saving of \$0.62 per day of ten hours with coal at \$1 per ton. With coal at \$2.50 per ton this saving would amount to \$1.55 per day or \$565.75 per year, which capitalized at 5 per cent. represents \$11,315.

The coal used during the test was raw screenings, which accounts for the low evaporation of the boilers. Where a washed nut or other good grade of coal was used the saving would be even greater than is shown above.

Committee:—C. R. Knowles, chairman; John Ewart, James Dupree, J. B. White and C. F. Warcup.

DISCUSSION.

A. S. Markley (C. & E. I.) criticized the practice of using locomotive boilers discarded by the mechanical department, and stated that it was his practice to install new boilers wherever required at pumping stations. A 50 h. p. boiler cost \$650.

G. W. Rear (S. P.) believed that old locomotive boilers can be employed to advantage for pumping plants, as they are worth nothing as scrap when it costs more than their scrap value to cut them up. Where a low rate for electricity can be secured, as in connection with the lighting of an office building or running machines in a shop, electrical pumping plants are more economical than steam or gasolene, and have been found to be entirely reliable. At such points a low rate for electric power can be secured because of large consumption. He has found it difficult to secure authority to purchase new boilers when old locomotive boilers were available because of increased first cost. C. R. Knowles (I. C.) said that the data regarding the cost of operation of an old locomotive boiler was given in the report to show that, even if this boiler cost nothing, the cost of operation is equivalent to 5 per cent. on an investment of \$11,000, so that it did not pay to use it even then. While the saving in a return tubular boiler is largely in decreased fuel consumption, it is also evident in the decreased repairs necessary because of the difficulty in keeping the vertical or locomotive boilers clean.

W. E. Alexander (B. & A.) stated that he has had several vertical boilers in service for 20 years with no accidents, and they are still rendering good service. He also uses a number of gasolene engines. In one instance one man operates four gasolene pumps, going from one station to another by trains. A. S. Markley also reported good service from vertical boilers.

In discussing the subject of attention to pumping plants, P. J. O'Neill (L. S. & M. S.) stated that gasolene or electric installations were more economical than steam for stations using 50,000 gallons or less of water daily, because steam plants require skilled attendants. By keeping the oil cups full and installing automatic control, gasolene or electric plants can be operated with less attention. C. R. Knowles stated that the report considered the fuel charges only and omitted the attendance charges. If the same class of men are employed on gasolene as on steam plants, the gasolene engines will give as reliable service. However, the practice is to employ cheaper men and the service deteriorates. The delays to trains alone resulting from water stations being out of service will frequently pay for a good attendant. He stated that he has not found an automatic electric valve which will work successfully and that it must have attention if it is to give service.

A. S. Robinson (C. & N. W.) stated that the total cost of pumping ranged from 7 cents per 1,000 gals. in Chicago where over 4,000,000 gals. are consumed daily to 4 cents at smaller stations requiring 100,000 gals. He considered 5 cents per 1,000 gals. a good average figure and suggested that the data in the report be revised to include this unit cost, as the managers want to know the cost of pumping water by various means in these terms. In reply Mr. Knowles stated that the cost per thousand gallons is misleading because of variations in the cost of fuel, head pumped against, etc.

**SEWERS AND DRAINS.**

Sewers, as referred to in this subject, are intended to carry the waste matter from railroad buildings to the main sewer, stream or cesspool. Drains are used in connection with railroads for carrying off surplus water from buildings and pits, and are simpler in construction than sewers. Ordinarily they do not require tight joints and traps, and they are often built of wood or common drain tile; but the larger sizes are usually built of sewer tile.

After careful consideration we offer the following as a progress report.

**Material.**—For sewers cast iron pipe or vitrified sewer tile is recommended, as the condition may require. Cast iron soil pipe should be of standard weight, free from flaws, cracks, air bubbles or other imperfections, and should be tested to 50 lbs. water pressure previous to tarring.

Vitrified sewer tile should be of standard thickness, good quality, salt glazed and well burnt throughout its thickness; impervious to moisture, smooth and well glazed on exterior and interior surfaces, free from cracks, flaws, blisters, fire checks and other imperfections.

For drains, cast iron soil pipe or common sewer tile may be used, according to the local conditions.

**General Considerations.**—Sewers and drains should be carefully studied, surveyed and mapped out, both for greater accuracy of work and for location of the line afterwards. Particular stress is laid upon the importance of the grades, to avoid dips or depressions in the line.

The area of the trunk or main sewer should be equal to the area of all intermediate connections, allowing for difference in velocity of flow. The following table will give the approximate capacity of different sizes of drain pipe, in U. S. gallons per minute, for grades varying from 1 in. to 36 in. fall in 100 ft.

TABLE.

Fall per 100 ft.	Diameter of pipe in inches									
Inches.	3	4	6	9	10	12	15	18	24	36
1.....Gals.	13	27	75	205	267	422	740	1,168	2,396	
2.....Gals.	19	38	105	290	378	596	1,021	1,651	3,387	
3.....Gals.	23	47	129	355	463	730	1,282	2,022	4,152	
6.....Gals.	32	66	183	503	655	1,033	1,818	2,860	5,871	
9.....Gals.	40	81	224	617	803	1,273	2,224	3,508	7,202	
12.....Gals.	46	93	258	711	926	1,468	2,464	4,045	8,303	
24.....Gals.	64	131	364	1,006	1,310	2,076	3,617	5,704	11,744	
36.....Gals.	79	163	450	1,240	1,543	2,554	4,467	7,047	14,466	

Angles in sewers and drains should never be used where it is practicable to do without them. Under ordinary conditions, where it is absolutely necessary to make an angle in a pipe line, long radius bends should be used, on account of less interruption to the flow. Where it is necessary to provide cleanout basins in a pipe line they may be made to act as the turn. Where the angle is greater than 45 deg., brick or concrete turns, with a cleanout basin, should be used.

Where necessary, traps should be placed in the pipe line and a hand hole should be provided in the pipe line near each trap, so that the trap can be cleaned or raked. The trap alone offers some resistance to the flow, and where a hand hole is made in the trap it adds another probability of obstruction.

Drains should be provided with a screen or grating at the inlet to keep sticks and rubbish from entering. Where dirt, sand, boiler washings and other sediment are liable to enter, a large catch basin should be constructed as near as possible to the inlet end. In this materials may settle and may be removed from time to time. If the water carries a fine silt and the drain is of considerable length, other smaller catch basins should be placed in the line, for the same purpose. The large basin should have a depth of at least 3 ft., and the smaller one 2 ft., below the line of the drain.

When a pipe line is laid in soft earth or in a marsh, it is often necessary to provide a foundation to keep the pipe from settling. We find various methods used, namely: piling, cinders, a concrete base, timbers cross laid, wooden trestles, wooden cradles, and concrete cradles, all of which can be used advantageously.

Matters of this kind are decided largely with respect to the material locally obtainable.

Where a drain or sewer is laid by contract, frequent inspection of the work should be made during construction to see that specifications are being carried out, and, where necessary, a regular inspector should be assigned to the work.

**Laying.**—Where sewer pipe is laid under buildings or under granitoid or cement sidewalks or platforms, or under tracks, it should be of cast iron; otherwise it might be of best quality, salt-glazed, vitreous terra cotta. All cast iron pipes should be neatly and snugly fitted together, the joints being well caulked with picked oakum and molten soft pig lead, using 12 oz. of lead for each inch of diameter of pipe in which joints are made. No cement or putty joints should be permitted, and wherever connections are made they must be laid with "Y" branches, long curves and one-eighth bends.

Vitrified sewer tile should be laid with joints closely fitted together in such manner that there will be no shoulder or lack of uniformity of surface on the interior of the drain. Each joint should be wiped clean of mortar on the inside before another joint or pipe is laid. The joints should be well cemented together with a mixture of one part Portland tested cement and two parts of clean sharp sand. The cement should be pressed into the space between the socket and spigot so as to fill it completely. After cementing the joints together care must be taken not to disturb the pipe.

In laying common sewer tile for drains we recommend cementing the joints the same as in laying sewer pipe.

**Committee:**—R. O. Elliott, chairman, L. & N.; A. F. Miller, Penn. Lines; E. C. Morrison, So. Pac., and K. Peabody, N. Y. C. & H. R.

DISCUSSION.

The discussion of this report was directed largely toward the type of joints made. C. R. Knowles (I. C.) stated that he knew of cast iron pipe laid with cement joints and also with oak wedges, and stated that this might be satisfactory where the pipe did not settle or pull apart. At such places he recommended lead and oakum joints. J. Ewart (B. & M.) gave a rule used on his road and also by the city of Boston to determine the number of pounds of lead to use in a joint as double the diameter of the pipe. Thus 24 lbs. would be used for a joint in a 12-in. pipe. Using this rule he has had little trouble with leaky joints.

In discussing the laying of tile, A. S. Markley (C. & E. I.) stated that he usually lays drain tile without sealing the joints and cements sewer tile. A. S. Robinson (C. & N. W.) uses bell end tile for sewers and straight pipe with open joints for drains. After considerable discussion it was decided to eliminate the last paragraph of the report recommending cementing joints for drains the same as for sewers.

**MOTOR CARS FOR BRIDGE GANGS.**

As the subject of motor cars was discussed at length in the *Railway Age Gazette* of July 18, 1913, page 101, only those portions of this report not mentioned in the article referred to are given in the following:

After having prepared a circular letter to be sent to the various railroads requesting information concerning their experience with motor cars for bridge gangs, it was found that the *Railway Age Gazette* was engaged in tabulating the same information. The committee was given access to this information, and accordingly did not send out its letter but took the following information from the replies to their letter.

Inquiries were sent to 108 railroads, and replies were received from 95. In brief, it was found that 48 roads of this number had in use a total of 3,306 motor cars in all branches of maintenance work. These 48 roads were using 2,246 motor cars in section service for a period ranging from six months to four years, and 24 roads reported using 270 motor cars for bridge gangs for service varying from six months to three years.

The use of these cars for bridge gangs is in the early stages

of its development, as is shown by the fact that of the 3,306 cars reported, only 270 are used by bridge gangs on 24 roads. This is in spite of the fact that in many ways these cars are of greater advantage to bridge gangs than to section gangs. Because of the limited use of motor cars for bridge gangs up to the present time, only general conclusions can be drawn and this report must necessarily be one of progress only.

In connection with the results obtained by the use of motor cars for the use of bridge gangs, the engineer of bridges on a prominent railroad reports as follows in regard to the use of two motor cars for steel bridge gangs:

(1) "A two cylinder car is used on steel bridge painting. The men are housed in camp cars at some siding near a telegraph office and the motor car is used to haul them and their materials to the bridge sites and back. When the bridges are small it is necessary to have work on several of them under way at one time, on account of the necessity of allowing some to dry while others are being painted. In such cases the car is almost indispensable.

The men usually return to the outfit for dinner. The gang averages 12 to 18 men, and the distance traveled runs from about 40 miles per day to a maximum of 150 miles. The gasoline consumed is about one gallon for each 15 miles traveled. The time saved is about one-half hour per day per man, equivalent to a total of about \$2.50 per day, except that where jobs are small and much territory is to be covered, the saving runs to \$10 or \$15 per day.

"This car has been in use three years. The wheels have been renewed once. Other repairs have cost but a small amount.

(2) "We have a 3-cylinder car in use on steel bridge erection and repair work, to haul men and small tools from their camp cars on the nearest siding to work and back, usually with a trailer attached. The gang averages from 15 to 30 men; the distance traveled is about 30 to 40 miles per day; the amount of gasoline used is about one gallon per 10 miles traveled. The foreman estimates that he saves 40 to 80 hours labor per week, or the car is worth about \$3.50 per day. It has been in use for one year and has required no repairs.

"The motor cars have been very successful with us. The great drawback to them is the danger of collision with trains. We have found it necessary to make some very strict rules. We have had no accidents, but we have had some close calls."

As the result of our study your committee submits the following conclusions:

The method of using hand power to propel bridge men with their tools and material over the road is obsolete. Gasoline motor cars have ceased to be an experiment, and in the hands of careful men can be safely and economically operated. They will result in savings to the company and comfort to the men.

Your committee also wishes to make the following recommendations regarding the specifications of the cars used.

The car should be as light as is consistent with the requisite strength, and should not weigh more than 1,000 lbs. It should be designed so that the greater part of the weight is on the axle with the loose wheel to enable men to take it off of the track easily. If water cooled, the use of small pipes that freeze easily in cold weather should be avoided and the water cooling apparatus should not be added at the expense of very much additional weight.

The car should be designed so as to run at the same speed in either direction with equal safety. The motor should be started with the car at rest and the car started by use of a clutch or belt.

The maximum speed should not be more than 20 miles an hour. It is very desirable to have at least two speeds in either direction to enable it to pull heavy loads over steep grades at low speed and to increase the speed where the grades are lighter.

The car should be designed as simply as possible, and with a view of having all parts easily accessible.

R. C. YOUNG,  
L. S. & I., Chairman.

## DISCUSSION.

The consensus of opinion was that motor cars were economical for the use of bridge gangs. A number of men spoke favorably of their experiences. A. S. Robinson (C. & N. W.) urged that the heavy cars be constructed so that they could not exceed a speed of 15 miles per hour.

### TEMPORARY STRUCTURES FOR SUPPORTING TRACKS DURING THE CONSTRUCTION OF PERMANENT WORK, SEWERS, ETC.

The committee prepared a set of 15 questions which were sent out in the form of a printed circular letter to 240 members of the association and to other railroad officials. At the time of writing this report 58 replies had been received from 52 different railroads. After studying these replies it was decided that the information contained therein could best be presented in a summary. Although plans accompanied many of the replies, in practically all cases the practice is to follow as closely as possible standard trestle construction.

## LIST OF QUESTIONS AND SUMMARY OF REPLIES.

1. In locations where there has been no opening in the road-bed, do you put in temporary stringers and ties first, or drive piles first?

There is practically a unanimity of opinion as to the best method of making an opening under the track, as out of the 58 replies received, 45 recommend driving the piles first, while 4 prefer to put in the stringers first and drive the piles afterwards.

2. In locations similar to the above is your first choice piles, framed bents or crib work where conditions will permit the use of either?

Forty-seven reported favoring piles as first choice, two favored framed bents and four favored crib work.

3. To what depth do you excavate on each drift when using framed supports in locations similar to the above mentioned?

Eighteen reported that this method was not used, nine did not answer the question, six replied that the depth depended on the character of the ground, seven reported depths ranging from 12 in. to 15 ft., and the remaining replies were so worded that it was evident that the writers are not ardent supporters of this method of work.

4. What is the standard length of span for falsework?

The standard length of span for falsework as reported ranges from 10 ft. to 32 ft., and in most cases is the same as the standard trestle span, being changed to fit local conditions on a particular piece of work.

5. What is your practice on falsework spans longer than the standard?

In increasing the length of span the common practice is to first add more stringers and some use second hand I-beams, old girders or even trusses.

6. What width and depth of opening limit the use of stringers only, resting on earth at each end?

The answers received show that each of the writers has his own way of handling a case of this kind and that the methods as reported are nearly all different in actual figures given.

7. At what depth of fill would you tunnel instead of trestle?

8. What do you recommend for supporting tracks when a tunneling process is used?

Questions 7 and 8 were also answered in such a manner as to indicate that there was a considerable difference of opinion regarding the best way to do work of this kind, the depth of fill given varying from 10 to 50 ft. There is also a difference of opinion as to the amount of support needed for the track.

9. Do you prefer framed or pile bents, or grillage in supporting tracks when rebuilding bridges, where the bottom permits of framed bents?

Twenty-six replies favored pile bents, 21 favored framed bents, one favored grillage and the remainder would use either pile or framed bents, depending on the character of the ground.

10. Do you recommend a temporary detour trestle for traffic,

or a trestle under the existing bridge to permit dismantling the structure and carrying traffic in the reconstruction of bridges? At what limit of height of trestle do you consider that to be the governing feature?

Twenty-two reported not being in favor of using a detour trestle, eight reported in favor of it and six reported no experience or did not answer. The remaining replies can be classified among those reporting that they would use either method, the choice depending on the volume of traffic, how complicated the erection of the new bridge was and the comparative cost. The second half of the question was answered by 12 who gave figures varying from 10 ft. to 100 ft. as their idea of the height of the limiting trestle. Several others stated that they did not consider the height of trestle the governing feature.

11. Do you recommend building a new bridge complete on horses on one side, and rolling it in, or supporting the old structure on falsework and rebuilding in place?

The answers received to this question are hard to classify in two groups. The general opinion seems to be that with trusses it is better to build in place, and with girders to either lower them in place with derricks, steam cranes or gallows frame, or to erect them at one side and roll in.

12. When renewing steel structures is it advisable to take out the old metal floor system, replacing it with timber, or leave it until the new superstructure is ready to be put in when placing the temporary trestle for traffic and dismantling under the old structure?

Twenty-four replied that they favored leaving in the old floor system, five favored removing it, eleven reported no experience or did not answer, two that the method depended on the structure and the remaining replies went into such detail that they are not given in the summary.

13. In rocky bottom do you use long sills for the whole horse, or short sills for separate posts, or omit the sills altogether on temporary falsework where the bottom is uneven?

Eight replies favored the use of long sills leveled up or anchor-bolted to the rock, nine favored short sills, 22 would omit sills altogether, five did not answer, and three stated that the method would depend on the character of the bottom and the velocity of the stream.

14. Bracing. Details of, for (a) simple trestle; (b) double deck, that is, with pony bents.

15. Pony bents—how attached to main bents (scab plates, metal or wood bolted or nailed). Do you use runner timbers or girts on top of main bents?

Twenty-nine answers to question 14 were received and as already stated the practice seems to follow very closely the standard trestle plan of each individual road. This is also true of the 35 replies received in answer to question 15.

#### RECOMMENDATIONS.

The committee recommends that piles be driven before stringers are put in, as they can be driven so that they will be directly under the stringers and will not have to be pulled or jacked into line; the fill under the track is not badly disturbed when putting in caps, only a small amount of blocking is needed to keep the track safe for full speed of trains at all times, and the work of placing stringers is made easier by having caps in place to slide the stringers on.

In cases where there is a choice of piles, framed bents or crib work the committee would recommend that as a general rule piles be used.

In places where the bottom is soft or uncertain, or where there is the slightest chance for scour by water, the committee would recommend that piles be always used, and that they be driven, if possible, at least 4 ft. below the bottom of the proposed excavation.

The method of excavating on each drift when using framed supports in locations such as the above as already stated does not appear to be favored by many members and the committee

feels that no definite recommendation can be made, as the safe depth very largely depends on the character of the material in the roadbed and the time available for work between trains.

The committee would recommend that where local conditions permit the span length be the same as the standard trestle span, which will permit of using stringers from stock, and in many cases second hand material can be used.

On spans longer than safe timber stringer construction the committee recommends the use of I-beams or girders.

The committee recommends that whenever stringers only are used they be supported on cross-sills at the ends, except when the width of excavation is to be small compared to the length of stringer. As a general rule the depth which can be excavated is such that a 1½:1 slope from each side of the bottom of the excavation will not undermine the sills under the ends of the stringers. This can not be given as a rule to be always followed, as in some soils a 1:1 slope would be safe and in others a 2:1 slope would be unsafe.

The replies to the two questions regarding tunneling under tracks as already stated show such a diversity of opinion among the members and others, and there was so little actual construction experience reported, that the committee prefers to leave these two questions without any definite recommendations.

The committee recommends the use of piles, rather than framed bents or grillage as a general rule, as being safer.

The committee recommends the use of a detour trestle when a suitable alinement of track can be obtained and the cost of this method will not be materially more than that of a trestle in place.

The committee recommends the method of rolling in a bridge when conditions will permit, and the expense is not materially greater. In cases where it is not possible to roll in and the new bridge must be rebuilt in place, the committee recommends that whenever possible the old metal floor system be left in and that the falsework be designed with this in view.

Where the bottom is uneven, the committee recommends that short sills be used when possible, unless the bottom is rock, in which case the sills may be omitted entirely; in either of these cases care should be taken to have all bents well braced, with crossbraces as low as possible.

The recommendation of the committee on the question of bracing is that the standard trestle plan be followed in detail as far as possible.

The committee recommends the use of wooden scab plates on temporary work, securely spiked or bolted; it also recommends the use of runner timbers or girts in all cases at every break in the uprights.

Committee: W. C. Whitney, chairman, B. & A.; J. B. Sheldon, N. Y. N. H. & H.; J. P. Canty, B. & M.; G. Aldrich, N. Y. N. H. & H.

#### DISCUSSION.

R. H. Reid (L. S. & M. S.) described methods of constructing false work under main tracks so that full speed may be maintained. In some instances, two and three decks of trestles must be built where building subways.

J. S. Robinson (C. & N. W.) stated that when replacing wooden boxes with cast iron pipe, piles are driven in banks up to 12 ft. high; banks are tunneled when from 20 ft. to 40 ft. high.

#### CATTLE GUARDS.

There are two principal and elementary characteristics pertaining to the installation of cattle guards: the necessity therefor; and the type of structure. Necessity may be considered the result of two conditions: statute requirements and industrial economy; or, in other words, the installation of stock guards may be required by the laws of the commonwealth or may be necessary for economical reasons, in which latter case the second elementary characteristic, type of structure, has an exceedingly important bearing. Accordingly, inquiries, segregated between legal and physical features, were sent to officials of 127 railroads, over 100 miles in length, in the United States

and Canada. Replies were received from 75 railroads aggregating 134,239 miles in length.

A compilation of the laws of the various states regarding the installation of cattle guards was made in 1903 by the standing committee on "Signs, Fences and Crossings" in the American Railway Engineering Association, which compilation was published in the proceedings of that association. The committee considered it advisable to ascertain if any important changes had been made in the statutes of the various states since the date of the former compilation.

As might be expected, these inquiries brought out a diversity of opinion as to the legal status in any one state. For example, several railroads operating in the same state answered the questions different for that state, thus showing widely varying interpretations of the statutes therein. Closely coupled with the legal phase of the situation is the element of industrial economy. Generally, whether required by statute or not, stock guards are not so essential from an economical standpoint in regions where but few domestic animals are raised as they are in those districts where large numbers are kept.

Replies to inquiries indicate that there is no legal protection afforded by the installation of stock guards, and where stock is killed contemporaneously with the maintenance of guards in good condition claims are legally allowed on the assumption that the guards are not effective barriers, although in perfect order. It also appears that neither the approval of type by railroad or public utilities commissions nor conformity to statute requirements in design relieves the railroads from responsibility for stock killed. There would therefore seem to be no other alternative than the past practice of installing guards in strict conformity to local laws, allowing the matter of efficiency to rest with the available types of guards thus far devised.

Answers to inquiries regarding the present practice in the installation and maintenance of stock guards show that while the standard plans of 78.5 per cent. of the mileage reporting provide for painting or whitewashing guards or some of their appurtenant parts, the opinion of engineers is about evenly divided as to the efficacy of such coating in barring stock. It seems to be quite the general opinion, however, that at least the wing fences should be maintained in white.

Only a very small percentage of mileage reported a practice of removing track sections of surface guards during the winter season. The maintenance of guards on 85.92 per cent. of the mileage is performed by track forces, although on a portion of such mileage the installation of guards is effected by bridge and building forces.

One railroad reports it economical to eliminate guards entirely as fast as they need renewal, and some of the eastern lines report few guards in use because of recent track elevation or grade crossing elimination. It is to be noted that on a small percentage of mileage reporting, pit guards are still in use and that on a larger percentage some types of modified pit guards are standard. By far the greater mileage, 81.26 per cent. of the total, employs one of the several forms of surface guard, and a decided preference is for a wooden slat design.

#### CONCLUSIONS.

After a study of the entire situation and thorough consideration of all the information at hand the committee begs to offer the following suggestions and conclusions:

**Legal Status.**—There has been recently very little, if any, change in the legal status of the matter.

**Modified Pit Guards.**—Realizing the effectiveness of the old pit guard, engineers have spent considerable study and effort in the design of a structure embodying therein only those features of the pit guard which are positive stock barriers without introducing the element of danger. The result is seen in the several types of modified pit guards. While these may all be said to be thoroughly effective as barriers, it is questionable whether some of them have eliminated all possible chance of danger. For ex-

ample, a pit with stringers and cross ties may be impassable for stock, but neglecting the matter of expense, the bridging of an opening 8 or 10 ft. long in this manner constitutes at least a very undesirable structure in a railway roadbed. Moreover such a structure does not entirely avoid the possibility of holding fast on the track a frightened animal with broken or entangled legs. A decidedly better construction, and one which is virtually as effective, is another type of modified pit guard consisting essentially of deep cross ties so spaced in proportion to their depth as to afford no knee room for an animal in taking a step. By making the cross ties of sufficient depth for barring the larger animals it also serves as a barrier to the shorter-legged animals, sheep and swine. This type evidently embodies the correct preventive principles, for it neither injures the feet of animals nor presents the slightest opportunity for entrapping even the smallest hoof.

**Metal Surface Guards.**—Owing to a minimum of objections to surface guards from an operating standpoint, more attention has been given to their design than to any other type. In the various kinds of metal surface guards the principal recent developments consist in the use of devices designed to render the passage of an animal thereover impossible by reason of painful injuries inflicted on its feet. This is evidently an incorrect principle, since animals, unlike the human family, cannot be disciplined by example, and the desired result would apparently be more satisfactorily accomplished by the erection of a barrier so formidable in outward appearance as to be shunned by animals of every description. Almost all commercial types of metal surface guards have some serious inherent objections, and those which are somewhat effective in turning the larger animals are usually a menace in other respects.

**Wooden Surface Guards.**—It is doubtless due to the many well known objections and shortcomings of most of the metal surface guards that the wooden slat guard is used so extensively, and while some of the bad features and lack of universal efficacy of the metal are present in the wood, there are so many other desirable characteristics in the wooden slat type as to render it the best form of surface guard. Of late years the important changes in its design have had more to do with the method of attaching the slats to the ties rather than to any variations in general style.

**Painting.**—As between the use of whitewash and cold water paint, little can be said in favor of whitewash, for even though the cost of the cold water paint itself be double that of whitewash, only about one third the number of applications are necessary to maintain the desired appearance.

In view of the foregoing observations, the conclusions of the committee may be summarized as follows:

Conformity to law in the installation and maintenance of stock guards is essential insofar as such conformity is a physical possibility without interposing any obstacles to the safety of train operation.

Climatic conditions, statute requirements, range laws and the scope of animal industry all have a bearing on the proper type of guard. It would therefore seem impossible for any one design to satisfactorily meet the demands of the various localities.

It is more difficult to erect positive barriers against stock accustomed to roaming wide areas of public domain than against more thoroughly domesticated animals.

At the present time there is known no absolutely effective guard entirely free from objectionable features.

Elimination of objectionable or dangerous features usually necessitates a sacrifice of efficiency.

Wide variations in cost of installation, repairs and renewals, as well as in cost of general maintenance of track, are possible without affecting the efficacy of the guard as a stock barrier.

Generally wooden slat surface guards embody a minimum of objectionable features and are probably just as efficient as



most of the types of metal surface guards now in use. Aprons and at least the adjacent panels of wing fences should be maintained in white, and for this purpose paint is decidedly preferable to whitewash.

STATUTE REQUIREMENTS FOR STOCK GUARDS IN THE UNITED STATES AND CANADA.

	Per cent. total production in U. S.		Guards required by statute.		Statutes permit roaming of stock upon public domain.
	Cattle, horses and mules.	Sheep and swine.	Against cattle, horses and mules.	Against sheep and swine.	
Maine	0.44	0.24	Yes	No	No
New Hampshire	0.25	0.08	Yes	No	No
Vermont	0.63	0.19	Yes	Yes	No
Massachusetts	0.38	0.13	Yes	No	No
Rhode Island	0.05	0.02	No	No	No
Connecticut	0.29	0.07	Yes	No	No
New York	3.62	1.43	Yes	No	No
New Jersey	0.38	0.17	Yes	No	No
Pennsylvania	2.64	1.72	No	No	No
Delaware	0.12	0.06	No	No	No
Maryland	0.57	0.49	No	No	No
Virginia	1.49	1.41	Yes	Yes	Yes
West Virginia	0.91	1.02	Yes	No	No
North Carolina	1.26	1.36	Yes	Yes	Yes
South Carolina	0.78	0.71	Yes	Yes	Yes
Georgia	1.82	1.93	Yes	Yes	County option
Florida	1.16	0.91	Yes	Yes	Yes
Ohio	3.26	6.17	Yes	Yes	No
Indiana	2.73	4.59	Yes	Yes	No
Illinois	4.78	4.85	Yes	Yes	No
Michigan	2.59	3.11	Yes	Yes	No
Wisconsin	3.99	2.46	Yes	Yes	No
Kentucky	1.98	2.58	Yes	Yes	Yes
Tennessee	1.93	1.98	Yes	Yes	County option
Alabama	1.62	1.42	Yes	Yes	County option
Mississippi	1.84	1.52	Yes	Yes	Yes
Minnesota	3.71	1.96	Yes	Yes	No
North Dakota	1.71	0.55	Yes	Yes	No
South Dakota	2.35	1.45	Yes	Yes	No
Nebraska	4.54	3.94	Yes	Yes	County option
Iowa	6.99	9.25	Yes	Yes	County option
Missouri	4.53	5.30	Yes	Yes	No
Kansas	4.78	2.66	Yes	Yes	County option
Oklahoma	3.34	1.26	No	No	County option
Texas	9.74	3.89	Yes	Yes	County option
Arkansas	1.73	1.59	Yes	Yes	County option
Louisiana	1.36	1.54	No	No	Yes
Montana	1.42	4.38	Yes	No	Yes
Wyoming	0.92	4.25	Yes	No	Yes
Idaho	0.79	2.69	Yes	No	Yes
Utah	0.69	1.76	Yes	No	Yes
Colorado	1.72	1.52	Yes	No	Yes
New Mexico	1.39	2.84	Yes	Yes	Yes
Nevada	0.63	1.25	No	No	Yes
Arizona	1.06	1.30	Yes	No	Yes
Washington	0.84	0.62	No	No	Yes
Oregon	1.13	0.42	Yes	No	Yes
California	3.12	2.96	No	No	Yes
Dominion of Canada	....	....	Yes	Yes	Yes

NOTE.—Where statutes do not specifically mention stock guards it is very probable that fence laws are such as to render guards necessary. In states where there is doubt as to the inclusion of barriers against sheep and swine in the stock guard statute it is assumed in above statement that such guards are to be so constructed as to be barriers to all kinds of live stock.

ARTHUR RIDGWAY,  
Chairman (D. & R. G.).

DISCUSSION.

G. W. Rear (Southern Pacific) believed that the dangers of pit cattle guards are over-estimated. The principal danger of the deep pit cattle guards arose from the cattle themselves becoming lodged and derailing trains and motor cars.

A. S. Markley (C. & E. I.) stated that cattle guards have been taken out on his division. The laws of Illinois forbid cattle running loose on the highways, so cattle guards are not needed.

J. M. Staten (C. & O.) described a test conducted by the Roadmasters' Association at Atlanta, Ga., several years ago with four patented cattle guards and a wood tie guard, by placing feed beyond the guards. The cattle crossed all but the tie guard. President Killam described a similar test conducted by the Canadian government at Ottawa in which cattle crossed all guards.

SNOW FENCES.

The opinions regarding the merits of snow fences expressed in replies to our circular letter were not unanimous regarding their advantages. It is the belief of the committee that where conditions prevent the placing of fences in advantageous positions, no benefits and much harm may result from their use. To make this point clear, the first essential to the use of snow fences is that there shall be sufficient space between the cut and the nearest string of fence (assuming that

the worst places require more than one row) to prevent the drift formed by this fence from extending into the cut. Experience based upon personal observation during one severe winter will enable one to decide upon the proper location of the fence. It should, of course, be placed as nearly windward from the cut to be protected as possible. Because of the varying direction of the wind, this will not always be possible, but the prevailing direction will govern. It is probably true that in most locations nearly all the bad storms come from one direction. A second string of fence should be placed parallel with the first and far enough away that its drift will not ordinarily lap over the first. Additional strings of fence as required can be located in the same manner. It is evident that if these parallel rows of fence cannot for any reason be placed far enough apart or far enough from the cut to prevent the drift from forming in the cut, harm rather than benefit will result. In this way, in agricultural communities where the railways own only a narrow right of way, snow fences cannot be used advantageously.

At the higher elevations on the Union Pacific where the greater portion of the land has but little value for other than grazing purposes, the company has the privilege of locating its fences to secure the best results, and it will frequently place four or five parallel rows of fence spaced 150 to 200 ft. apart where the land slopes downward towards the cut to be protected. On the other hand, where the ground rises abruptly towards the cut it is necessary to place these strings 50 ft. or even a lesser distance apart.

Mr. R. Budd, chief engineer of the Great Northern Railway, advises that tree planting is being done to a large extent in eastern Montana, North Dakota and Minnesota, and is proving a very effective means of protection against winds blowing across the track. The same effect is produced where sage brush or any other form of vegetation provides a lodgment for the snow.

We recommend for general use a portable type of snow fence built of 1 in. x 6 in. x 16 ft. rough fencing lumber braced and nailed to supports of 2 in. x 6 in. timbers. Such a fence stands about 7 ft. high and is built in 16 ft. panels. The bottoms of the supports are connected by a 2 in. x 6 in. x 8 ft. timber to brace them on the ground, and to keep the supports spread. Hardwood stakes 3 in. x 3 in. in size or 3/8 in. round iron fastenings are used to anchor the fence to the ground and to prevent it from blowing over during high winds. Stone is also sometimes used when convenient. This fence is standard on the Oregon Short Line; the Chicago, Milwaukee & St. Paul; the Duluth & Iron Range and the Union Pacific. The legs of this fence swing on a bolt located three boards below the top and are held apart by a 2 in. by 6 in. timber bolted at the bottom. This fence folds up so that it occupies a vertical space of only 8 in. when lying upon the ground or when loaded upon cars.

In erecting the fence a form is constructed for nailing up the panels and four active men will set up a panel ready for loading on cars every four minutes. Where much fence of this type is to be erected, a work train is generally employed and the fence is unloaded from the cars as conveniently as possible. It is hauled from the cars to its location off an ordinary lumber wagon fitted with a rack. Care should be taken to start the erecting of the fence early in the fall, say in September, so that work can be completed before bad weather comes and frost interferes with the driving of the stakes which hold the panels down.

The chairman of this committee has had much experience with snow fences during his service of over twenty years on the Union Pacific and has had no fences other than of the portable type in use. However, the committee does not wish to be understood as recommending the portable pattern because it can be moved during the winter storms, as fence moved under those conditions will be damaged considerably. If necessary, we advise making and placing new fence after the original fences have

become buried in the drifts. The economy of this practice will be evident when the fences are repaired the following season.

We find that it is customary to make a snow fence serve the purpose of a right of way or boundary fence in many instances. The conditions are exceptional where such a fence will provide the proper protection against snow and we recommend a careful study of local conditions, including the direction of prevailing winds and the lay of the land before placing fences anywhere.

Committee: A. H. King, chairman (O. S. L.); F. E. King (C. M. & St. P.); C. F. King (C. & N. W.); Frank Lee (C. P. R.); C. S. McCully (N. P.).

#### DISCUSSION.

W. M. Clark (B. & O.) stated that he piles the snow fences on old ties on the right of way in the spring, and in the fall sends a carpenter out with lumber and the fences are repaired as set up.

W. E. Alexander (B. & O.) described the practice on his road of turning the care of snow fences over to the track forces. Portable and permanent inclined fences have been tried and found unsatisfactory. A vertical fence 10 ft. high, boarded tight and built permanently in place has been found most satisfactory.

#### PRESERVATION OF TIMBER.

A great deal can be done to lengthen the life of untreated timber, viz.:

1. By the selection of the proper varieties for the different parts of the structure—using the woods that are durable in contact with the soil for piles and footings, and the pines and firs for that part of the structure which requires strength but is not in contact with the soil.

2. By using concrete or masonry footings and keeping all timber away from the ground.

3. By keeping drift and other accumulations away from the timber (this applies to the stringers and caps as well as to the sills and posts).

4. By cutting the timber at the right season of the year and taking proper care of it during seasoning.

5. By protecting the structure from the weather.

Piles decay almost invariably at or near the ground line, and many methods have been adopted to increase their life when they become badly decayed, some of which are:

1. Splice individual piles by cutting them off below the ground. This method is good where only one pile in a bent is decayed, but not more than one pile in a four pile bent or two in a five pile bent should be so repaired.

2. Cut off all piles in a bent below the ground and put on a framed bent. This is a good method and is probably the most practical one.

3. Either before or after a pile has become decayed encase it in concrete for about two feet below to two feet above the ground line. If the pile is decayed some vertical reinforcement is necessary, and in any case it is advisable to place some wire netting around the pile. If properly done this method is probably the best and the trestle will not lose any of its stiffness. The cost will average about \$5 per pile and it will then be good for several years. Of course the condition of other parts of the structure should be taken into account before applying this method to many piles, as it would probably not pay to repair them in this manner unless the deck is good for three or four years.

The committee will not make any recommendation as to treating processes, but advises that the treatment be such as to give the following results:

For piles and other parts of a structure, that come in contact with the soil, a full cell treatment should be given, injecting all the oil the timber will take. This is especially necessary in piles on account of their liability to shatter or check in driving. For timber not in contact with the ground a cheaper treatment may be advisable, but as deep a penetration as possible should be obtained, regardless of the quantity of creosote left in the timber.

Whenever possible all framing of timber should be done be-

fore treatment, even to the boring of holes, but it is very seldom that this can be done. On a trestle the only framing absolutely necessary is to cut the piles to the right height and apply the braces. Stringers, ties, etc., can be framed and treated before going to the job, but this requires a refinement of workmanship not easily attained.

When piles are cut off, the heads should be thoroughly saturated with hot creosote, after which a good coat of hot asphaltum or tar should be applied. If the cap does not entirely cover the piles, the heads should be chamfered on the sides, so the water will run off quickly and not work under the cap. Vertical bolt holes should be filled with hot creosote before bolting and those in caps should be bored before treatment.

Braces should be fitted to the piles and in no case should the skin of the pile be cut. Piles should be selected so all in one bent would be of approximately the same size and any large protrusions on the piles should be cut off before treatment.

No satisfactory method of treating horizontal bolt holes has been developed. It is not practical to fill the holes with creosote. It may be said that twenty years' experience with such work has not shown the necessity of treating them in any way, but where the piles are in water that varies in height, some treatment may be necessary. Experiments might be made by boring the holes a trifle small and burning them to size as the charring of the wood might help. However, if the bolts are kept tight there will be little trouble. In such cases it would probably be best to spike the braces on with boat spikes.

In most cases it does not pay to creosote braces and girts as they have a reasonably long life and are easily replaced. There is also a considerable amount of framing to be done on them and this would to some extent impair the value of the creosote. A good brush treatment with creosote after framing or, better, a good soaking in a tank of hot creosote is probably as good as a pressure treatment for girts and braces if they are of the usual small sizes.

As a rule, we would recommend the use of piles of cedar or cypress, untreated or with a brush coat at the ground line, whenever they can be obtained at a price of about 60 per cent. that of creosoted material. We would recommend creosoted piles of the cheapest available material for all structures that are expected to be in use ten or more years, where cedar, cypress or white oak cannot be obtained at a favorable price. We do not recommend the use of creosoted material for caps, braces, stringers and ties of open deck trestles, but do recommend it for all parts of ballasted deck trestles. The above recommendations are to be considered as general and are not intended to apply to localities where untreated material has a very short life.

Where framed bents are used on a pile foundation, the piles should be cut off high enough to keep the sill of the bent clear of the ground (the higher the better). The question of preserving the material will depend on the cost of material and its economy in yearly cost, giving the preference to preserved material on account of the lessened delays to traffic due to reconstruction.

Along the seacoasts the timber in marine structures is subject to the attacks of wood borers, commonly known as shipworms and wood lice. There being no way to destroy the borers, it is necessary to protect the timber in some way to prevent or retard their attacks and the following methods have been used:

1. Use piles with bark on. The borers will not attack piles with the bark on and this is one of the best methods to use, but as a very small exposed surface will permit of their attacks, care must be taken to keep the bark intact while handling and driving. Where boats tie up to a wharf or where much drift is afloat it is impossible to keep the bark on. However, all piles driven in water infested by borers should have the bark on, unless given other treatment.

2. Use an artificial bark of sheathing. This method has the same advantages as natural bark and practically the same disadvantages.

3. Insert flat-headed nails to completely cover the parts of pile exposed to attacks. This method is very expensive and unless copper or galvanized nails are used they soon corrode and fall off.

4. Cover the exposed surface with fabrics saturated with tar or asphalt or mixtures containing them. This method is good while it lasts, but it will not last long in rough water or where boats or drift comes in contact with it.

5. Cover the piles with copper, zinc or other metal sheathings. Copper and zinc are good, but expensive and are liable to be removed by thieves. Iron has to be thick to resist corrosion and is expensive.

6. Cover the piles with a cement coating, either before or after driving. In using this method it is customary to place wire netting around the pile with one or two inches of cement mortar, either applied as a plaster or by using a form and casting it. This method has been used with good success on tide lands where the mud is exposed at low tide and has also been used to protect and reinforce piles which have been partially destroyed. While liable to be broken off by drift, etc., it is easily replaced and can be recommended for such locations.

An additional objection to all of these methods is that no provision is made for increased depth of water, due either to scour or dredging.

Another method in use is to place a cement pipe around the pile with an intervening space of two or more inches which is filled with sand. This pipe is usually made in lengths of two to three feet and in pieces locked together, so that it can be put on a pile at any time without disturbing the cap. This method may be good in some locations where the water is smooth and no drift or boats are liable to strike the piles, but as a general thing it is doubtful if it will give satisfactory service.

The only other practical method is to inject poisonous substances or oils into the timber, either throughout the entire length of the pile or in that part above the mudline. The use of poisonous substances is not recommended as they require very careful handling and will leach out when exposed to salt water.

Very satisfactory results have been obtained from the use of creosote, and the only objection to it is the expense. Often, on a pile 80 ft. long only 10 to 15 ft. will be subject to attack. In using the pressure process, the entire pile must be treated and this costs over \$20 a pile, or about double the cost of a pile untreated. If only 15 ft. could be treated this would not cost over \$4 and would give as good service. This can be done by the open tank process and there may be some varieties of timber that will absorb enough creosote by this process to be satisfactory, but experience has shown that to successfully withstand the attacks of the borers every ounce of creosote possible should be injected into the timber. Consequently, where the borers are active and piles are intended to have a life of two or more years, we recommend that they be treated by the pressure process and creosote injected to refusal. With Douglas fir this will probably be from 12 to 16 lbs. per cubic foot, and with the pines from 20 to 24 lbs. Experience with creosoted timber resisting borers has shown remarkably good results, although there have been some failures due either to insufficient treatment or to mechanical damage in handling after treatment. In handling creosoted piles to be used in salt water great care should be taken to prevent damage to the outer skin, either from holes made by cant hooks, or from checks caused by hard driving. Where piles can be placed with a water jet such a method is recommended and the use of steam hammers is better than that of drop hammers. Of course, drop hammers can be carefully handled and piles driven with them without damage, but there is always a temptation to drop the hammer too far.

#### FENCE POSTS.

Practically all varieties of timber will give good service as fence posts if that part that goes in the ground and for about six inches above the ground is treated with preservative; but water oak, maple, sycamore, cottonwood, quaking aspen and possibly others should be treated full length, as they decay rapidly above ground

as well as below. A brush treatment is of some value, but dipping the post in the preservative is better, as the checks and cracks are more likely to be filled. However, such treatment is only superficial and the results will not be as satisfactory as they would be if a more thorough impregnation is given. The open tank method of treatment is probably best for posts as the plant does not cost a great deal and it can be moved from place to place easily. Posts should be peeled and seasoned before treatment. Sapwood takes treatment better than heartwood and round posts are to be preferred, but the heartwood of a few varieties takes treatment quite readily and they can be split.

Committee: George W. Rear (S. P.), F. D. Mattos (S. P.), F. D. Beal.

#### DISCUSSION.

J. M. Staten (C. & O.) told of a creosoted pile trestle one mile long and 25 years old at Point Comfort which is now beginning to require some repairs. He also stated that the Louisville & Nashville uses creosoted timber for water tank frames, assembling the material before treatment.

#### OTHER BUSINESS.

An extensive report on track scales was presented and discussed and was accepted subject to possible revision.

Mr. Bonsfield, of the Fairbanks Scale Company, described a new scale car of the Bureau of Standards and the results secured on recent tests. He called attention to the earnest spirit of co-operation between the government and the railways in improving the condition of scale equipment. He advocated broad specifications for scales to permit consideration of local conditions. In reply to a question he said he used a maximum allowable load of 5,000 lbs. per line inch of knife edge.

A short report was presented on fire resisting coatings for timber, describing tests of several trestles built for this purpose and painted with different preparations. They were tested last summer with severe fires and all burned eventually, but showed the fire retarding qualities of the paints. In the discussion C. Ettinger stated that all paints which include whitewash are retardant to some extent; tests of structures with fires created by large piles of hay underneath are, he claimed, unfair. J. S. Robinson stated that the fact that decayed timber on test structures was last to burn was due to the greater absorption of protective paint. A number of members spoke of very satisfactory results from fireproof paints and gave comparative data showing the decrease in the number of fires after the application of paint.

On Tuesday afternoon the ladies were the guests of the Supply Association on a tallyho sightseeing trip about Montreal, and Wednesday evening the members and their families attended a theater party. Thursday afternoon was spent on a boat trip and an inspection of the Dominion Bridge Company's shops, at which the Quebec bridge will be fabricated. A trip to Ottawa was made on Friday.

Los Angeles was selected as the meeting point for the next convention. The following officers were elected:

President, J. N. Penwell, supervisor of bridges and buildings, Lake Erie & Western, Tipton, Ind.; first vice-president, L. D. Hadwen, engineer of masonry construction, C. M. & St. P., Chicago; second vice-president, G. Aldrich, bridge supervisor, New York, New Haven & Hartford, Boston; third vice-president, G. W. Rear, general inspector, Southern Pacific, San Francisco; fourth vice-president, C. E. Smith, assistant chief engineer, Missouri Pacific, St. Louis; secretary, C. A. Lichty, general inspector, Chicago & North Western, Chicago; treasurer, J. P. Canty, superintendent of bridges and buildings, B. & M., Boston; members of executive committee, W. F. Strouse, assistant engineer, Baltimore & Ohio, Baltimore, and C. R. Knowles, general foreman water works, Illinois Central, Chicago.

The committee on subjects selected the following for next year's committee work:

- (1) Ice houses and the preservation of ice for railway service;
- (2) warnings for overhead obstructions;
- (3) railroad crossing gates, towers and other devices for highway crossing protection;

(4) construction of reinforced concrete bridge work; (5) station buildings for passenger service only; (6) mechanical coaling stations; (7) how to take care of traffic while constructing bridges to eliminate grade crossings.

and thousands. The figures shown across the bottom of the table are the miles in decimals for the even ten thousands of feet shown immediately above. To ascertain the miles that any number of feet represents, proceed as follows: Given 8,673 ft. to find the number of miles. First look in the vertical column headed 70, opposite the figure 3 in the first column and you will find .01383 miles, which is 73 ft. reduced to miles. Similarly in the column headed 0, opposite the figure 600 in the first column you will find .11364 miles, which is 600 ft. reduced to miles, and in the column headed 0, opposite the figure 8,000 in the first column you will find 1.51515, which is 8,000 ft. reduced to miles. The sum of these three numbers equals 1.64262 miles.

**A TABLE OF FEET REDUCED TO DECIMALS OF A MILE.**

By JAS. G. WISHART,

Chief Draftsman, Rock Island Lines, Chicago, Ill.

The table of feet reduced to decimals of a mile, shown herewith, will be found both accurate and convenient. The use of this table reduces the process to one of simple addition and in work where there is a quantity of this class of computing to be performed, will prove itself a time saver. The table has been figured to the fifth decimal, reducing to a minimum any errors due to the addition of several of the quantities.

The figures across the top of the table are even feet in tens. The figures in the first vertical column are even feet, hundreds

KOWLOON-CANTON RAILWAY, CHINA.—The British section of the Kowloon-Canton Railway (in the new territories on the Kowloon Peninsula), which was first opened for traffic on October 1, 1910, is 22 miles in length. The capital expenditure up to December 31, 1911, amounted to \$12,021,503, leaving available funds to the sum of \$275,426.

TABLE OF FEET REDUCED TO DECIMALS OF A MILE.

Feet.	0	10	20	30	40	50	60	70	80	90
0	.00000	.00189	.00379	.00568	.00758	.00947	.01136	.01326	.01515	.01705
1	.00019	.00208	.00398	.00587	.00777	.00966	.01155	.01345	.01534	.01723
2	.00038	.00227	.00417	.00606	.00795	.00985	.01174	.01364	.01553	.01742
3	.00057	.00246	.00436	.00625	.00814	.01004	.01193	.01383	.01572	.01761
4	.00076	.00265	.00455	.00644	.00833	.01023	.01212	.01402	.01591	.01780
5	.00095	.00284	.00473	.00663	.00852	.01042	.01231	.01420	.01610	.01799
6	.00114	.00303	.00492	.00682	.00871	.01061	.01250	.01439	.01629	.01818
7	.00133	.00322	.00511	.00701	.00890	.01080	.01269	.01458	.01648	.01837
8	.00152	.00341	.00530	.00720	.00909	.01098	.01288	.01477	.01667	.01856
9	.00170	.00360	.00549	.00739	.00928	.01117	.01307	.01496	.01686	.01875
100	.01894	.02083	.02273	.02462	.02652	.02841	.03030	.03220	.03410	.03598
200	.03788	.03977	.04167	.04356	.04545	.04735	.04924	.05114	.05303	.05492
300	.05682	.05871	.06061	.06250	.06439	.06629	.06818	.07008	.07197	.07386
400	.07576	.07765	.07955	.08144	.08333	.08523	.08712	.08902	.09091	.09280
500	.09470	.09659	.09848	.10038	.10227	.10417	.10606	.10795	.10985	.11174
600	.11364	.11553	.11742	.11932	.12121	.12311	.12500	.12689	.12879	.13068
700	.13258	.13447	.13636	.13826	.14015	.14205	.14394	.14583	.14773	.14962
800	.15152	.15341	.15530	.15720	.15909	.16098	.16288	.16477	.16667	.16856
900	.17045	.17235	.17424	.17614	.17803	.17992	.18182	.18371	.18561	.18750
1,000	.18939	.19129	.19318	.19508	.19697	.19886	.20076	.20265	.20455	.20644
100	.20833	.21023	.21212	.21402	.21591	.21780	.21970	.22159	.22348	.22538
200	.22727	.22917	.23106	.23295	.23485	.23674	.23864	.24053	.24242	.24432
300	.24621	.24811	.25000	.25189	.25379	.25568	.25758	.25947	.26136	.26326
400	.26515	.26705	.26894	.27083	.27273	.27462	.27652	.27841	.28030	.28220
500	.28409	.28598	.28788	.28977	.29167	.29356	.29545	.29735	.29924	.30114
600	.30303	.30492	.30682	.30871	.31061	.31250	.31439	.31629	.31818	.32008
700	.32197	.32386	.32576	.32765	.32955	.33144	.33333	.33523	.33712	.33902
800	.34091	.34280	.34470	.34659	.34848	.35038	.35227	.35417	.35606	.35795
900	.35985	.36174	.36364	.36553	.36742	.36932	.37121	.37311	.37500	.37689
2,000	.37879	.38068	.38258	.38447	.38636	.38826	.39015	.39205	.39394	.39583
100	.39773	.39962	.40152	.40341	.40530	.40720	.40909	.41098	.41288	.41477
200	.41667	.41856	.42045	.42235	.42424	.42614	.42803	.42992	.43182	.43371
300	.43561	.43750	.43939	.44129	.44318	.44508	.44697	.44886	.45076	.45265
400	.45455	.45644	.45833	.46023	.46212	.46402	.46591	.46780	.46970	.47159
500	.47348	.47538	.47727	.47917	.48106	.48295	.48485	.48674	.48864	.49053
600	.49242	.49432	.49621	.49811	.50000	.50189	.50379	.50568	.50758	.50947
700	.51136	.51326	.51515	.51704	.51894	.52083	.52273	.52462	.52652	.52841
800	.53030	.53220	.53409	.53598	.53788	.53977	.54167	.54356	.54545	.54735
900	.54924	.55114	.55303	.55492	.55682	.55871	.56061	.56250	.56439	.56629
3,000	.56818	.57008	.57197	.57386	.57576	.57765	.57954	.58144	.58333	.58523
100	.58712	.58902	.59091	.59280	.59470	.59659	.59848	.60038	.60227	.60417
200	.60606	.60795	.60985	.61174	.61364	.61553	.61742	.61932	.62121	.62311
300	.62500	.62689	.62879	.63068	.63258	.63447	.63636	.63826	.64015	.64204
400	.64394	.64583	.64773	.64962	.65152	.65341	.65530	.65720	.65909	.66098
500	.66288	.66477	.66667	.66856	.67045	.67235	.67424	.67614	.67803	.67992
600	.68182	.68371	.68561	.68750	.68939	.69129	.69318	.69508	.69697	.69886
700	.70076	.70265	.70454	.70644	.70833	.71023	.71212	.71402	.71591	.71780
800	.71970	.72159	.72348	.72538	.72727	.72917	.73106	.73295	.73485	.73674
900	.73864	.74053	.74242	.74432	.74621	.74811	.75000	.75189	.75379	.75568
4,000	.75758	.75947	.76136	.76326	.76515	.76704	.76894	.77083	.77273	.77462
100	.77652	.77841	.78030	.78220	.78409	.78598	.78788	.78977	.79167	.79356
200	.79545	.79735	.79924	.80114	.80303	.80492	.80682	.80871	.81061	.81250
300	.81439	.81629	.81818	.82008	.82197	.82386	.82576	.82765	.82954	.83144
400	.83333	.83523	.83712	.83902	.84091	.84280	.84470	.84659	.84848	.85038
500	.85227	.85417	.85606	.85795	.85985	.86174	.86364	.86553	.86742	.86932
600	.87121	.87311	.87500	.87689	.87879	.88068	.88258	.88447	.88636	.88826
700	.89015	.89204	.89394	.89583	.89773	.89962	.90152	.90341	.90530	.90720
800	.90909	.91098	.91288	.91477	.91667	.91856	.92045	.92235	.92424	.92614
900	.92803	.92992	.93182	.93371	.93561	.93750	.93939	.94129	.94318	.94508
5,000	.94697	.94886	.95076	.95265	.95454	.95644	.95833	.96023	.96212	.96402
100	.96591	.96780	.96970	.97159	.97348	.97538	.97727	.97917	.98106	.98295
200	.98485	.98674	.98864	.99053	.99242	.99432	.99621	.99811	1.00000	1.00190
6,000	1.13636	1.1553	1.1742	1.1932	1.2121	1.2311	1.2500	1.2689	1.2879	1.3068
7,000	1.32576	1.3447	1.3636	1.3826	1.4015	1.4205	1.4394	1.4583	1.4773	1.4962
8,000	1.51515	1.5341	1.5530	1.5720	1.5909	1.6098	1.6288	1.6477	1.6667	1.6856
9,000	1.70455	1.7235	1.7424	1.7614	1.7803	1.7992	1.8182	1.8371	1.8561	1.8750
10,000	20,000	30,000	40,000	50,000	60,000	70,000	80,000	90,000	100,000	500,000
1.8939	3.7879	5.6818	7.5758	9.4697	11.364	13.258	15.152	17.045	18.939	94.697

## General News.

Among 15 employees of the Illinois Central who will be pensioned on November 1, is Stewart Hazlett, a locomotive engineer, who is said to have been with the company for 47 years without missing a day's work.

According to a press despatch of October 19, 46 Mexican soldiers were killed by the dynamiting of a railroad train near Saltillo, while on their way from Mexico City to Torreon. The locomotive and two cars were destroyed.

In recognition of fifty years' service, the record for the division, the Erie Railroad has inscribed the name of Richard M. Shane, engineer, on the cab of the locomotive that he runs. Mr. Shane runs on the Cleveland-Pittsburgh line.

The Port Washington Branch of the Long Island Railroad, about 12 miles long, is now operated by electric power, the first passenger trains having been run through from the Pennsylvania station, New York City, to Port Washington, October 21.

Telegraph operators on the Missouri, Kansas & Texas have recently been conferring with the management on a demand for a 10 per cent. advance in wages, a ten-hour day, and extra pay for overtime and Sundays. Between 600 and 700 men are involved.

The firm of Hadley, Cooper, Neel & Wilson, of Kansas City, headed by ex-Governor Herbert S. Hadley, of Missouri, has been asked by a group of western railways to represent them before the Interstate Commerce Commission in connection with the physical valuation of railway property.

The New Jersey & Pennsylvania Railroad, which extends from Morristown, N. J., south to Whitehouse, on the Central of New Jersey, 27 miles, suspended operations October 20, on an order of the State Public Utility Commission. The track is in poor condition, the business has been very slim and the company's debts are more than it can carry.

The new locomotive shops of the Wabash at Decatur, Ill., were opened on October 18, and 200 men employed at the Springfield shops have been moved, or will move to Decatur to take positions in the new shops, to which has been transferred much of the machinery from the old plant. Officers of the Wabash held a banquet in Decatur on the evening of October 18.

The controversy between the Louisville & Nashville Railroad and the Western Union Telegraph Company, following the expiration of the lease under which the telegraph poles and wires occupied the railroad land, is still pending in the courts. At Lexington, Ky., recently, a suit was entered by the railroad against the telegraph company to recover \$672,273 alleged to be the amount of rentals accrued since August 17, 1912.

It was announced in New Haven this week that the New York, New Haven & Hartford Railroad Company had come to an agreement with its complaining engineers who have been threatening to strike. The announcement says that the rules agreed upon embrace all of the principles for which the management had contended, as well as all the safeguards against possible misinterpretations for which the men contended.

The railway terminal buildings at East St. Louis, Ill., were seriously threatened and some of them entirely destroyed by a fire which started late Sunday night and which was estimated to have caused over \$1,000,000 damage within 24 hours. The fire started in a grain elevator belonging to the Advance Elevator Company and spread to the Chicago & Alton freight house, the Baltimore & Ohio freight house, the Toledo, St. Louis & Western warehouse and the railway yards.

The annual convention of the Investment Bankers' Association of America will be held on October 28, 29 and 30, at the Blackstone hotel, Chicago. At the annual banquet on October 30, James J. Hill will speak on "Railroad Financing of the Future"; Frank A. Vanderlip, president of the National City Bank of New York, on "The Effect of the Proposed Banking Legislation on Corporation Securities," and Rev. Dr. Cavanaugh, Notre Dame, Ind., on the "Humorous Side of the Bond Business."

The "Safety First" propaganda is being carried on, not alone in the railroad world, but also in industrial establishments.

John A. Fitch, in an article in *The Survey*, says that a certain large steel plant, employing 5,000 men, has reduced the number of accidents by about 70 per cent. during the last ten years; and that 1913 showed a great reduction as compared with 1912. It is declared that the record of industrial accidents is worse in the United States than in any other important industrial country.

The Atchison, Topeka & Santa Fe has recently closed a contract with a California petroleum company, whereby oil from the Santa Fe's field near Bakersfield, Cal., will be conveyed over the Tehachapi mountains in a pipe to Mojave where it will be available as fuel for locomotives. The introduction of the pipe line will greatly relieve the railroad over the Tehachapi pass, which is used jointly by the Santa Fe and the Southern Pacific, and on which a very large part of the traffic has been fuel oil for the two roads.

The Illinois Central has issued an order forbidding engineers to carry pictures of wives, sweethearts or babies on their watch crystals. This is to prevent thoughts of home and other distractions from entering the minds of the men whose attention must be on signals, time and safety. The possibility of some veteran going off a switch while considering the matter of rent, or a novice wrecking a train with his eyes fixed on a picture of his sweetheart has been considered and is held to be of enough consequence to demand attention.

G. W. Kirtley, superintendent of transportation of the Erie Railroad, has issued a notice to agents, yardmasters and connections, to the effect that on account of sparks getting through hatches or ventilators; and also on account of car floors being flooded from ice bunkers, and for other reasons, the use of refrigerator and other ventilated cars for loading dangerous explosives requiring specially prepared and placarded cars is prohibited; and any such shipments loaded in refrigerators or other ventilated cars, offered by connections, will be refused.

The Panama-Pacific International Exposition Company, San Francisco, has nearly completed the installation of its own standard gage railway system, about 10 miles of track, to facilitate delivery of material and exhibits during the pre-exposition period. The system will extend from the ferry slips at the eastern end of the grounds, through the entire area occupied by the main exhibit palaces, thence to the live stock and aviation tracts at the western end, on the Presidio military reservation. There is a yard adjacent to the ferry slips with accommodations for 200 cars. Between February 20, 1915, and December 4, 1915, while the exposition is open, some of the tracks will be removed temporarily, but most of them will be buried beneath soil, and driveways, walks or gardens placed over them.

Members of the committee on mail transportation, with other railroad presidents, called on Postmaster-General Bursleson last week to urge a more reasonable payment to the railroads for carriage of the mails, and to ask immediate action in recognition of the great added weight of the parcel post. They express themselves as satisfied with the reception they received. They attach much importance to the Postmaster-General's assurances that he proposed to see justice done the railroads, and say they are confident he will perceive the strength of their case when he has had time to study the voluminous data on the subject. There is little prospect of obtaining an increase of pay until some time after Congress has received the report of the Bourne Commission. There is a bare possibility that the railroads will obtain an annual weighing on all lines, instead of the quadrennial weighing now practiced. This change lies within the present authority of the Postmaster-General.

The Denison (Texas) Chamber of Commerce has sent to the attorney general of Texas a resolution urging the withdrawal of the suit now being prosecuted against the Missouri, Kansas & Texas, under the anti-trust law. The resolution says in part: "The suit is, in our judgment, ill timed and is in direct conflict with the expressed will and desire of two legislatures of this state and is in conflict with the recognized Texans' ideas of a square deal; retards, if it does not stop, railway development in Texas, so necessary to the development of this great commonwealth and all its resources; will cause capital to hesitate long before making investments in Texas, even after the

legislature has spoken; will have the effect of discrediting this state before the world at large and will, in the opinion of this organization, be a serious detriment to Texas and to her people. We feel that no good can result therefrom, but great and lasting injury will be the only consequence. Without questioning the sincerity of purpose of the attorney general, we believe that further prosecution of this suit will be injurious and detrimental to the best interests of our state."

#### Seventeen Passengers Killed on the Mobile & Ohio.

In the derailment of a special passenger train on the Mobile & Ohio at State Line, Miss., 62 miles northwest of Mobile, on the afternoon of October 19, seventeen passengers were killed and 100 or more injured. The passengers were all soldiers of the United States Coast Artillery. According to the reports, the tender was the first vehicle to leave the track. It ran off the rails about 200 ft. from a trestle bridge and, with the baggage car and three coaches, fell about 25 ft. from the bridge to the ground.

#### Tests of Spheroidal Lenses.

The Armspear spheroidal lens, as used on tail-end markers and on switch lights, was subjected to elaborate tests on the evening of October 16 near Jersey City, the Armspear Manufacturing Company, New York City, having invited a committee of railroad officers to supervise a number of demonstrations on a curved track. The track in question is at Oak Island junction, on the Central of New Jersey; it is an 8 deg. curve, 1,140 ft. long. The committee consisted of M. A. Mulligan, trainmaster, Lehigh Valley; G. H. Wilson, superintendent, electric division, New York Central; and C. H. Stein, engineer of maintenance of way, Central of New Jersey. The tests were witnessed by a large party of railroad officers; the principal roads of the East being represented. The spheroidal lens, designed to spread the rays of a signal light so as to improve the efficiency of signals on a curved railroad, was described in the *Railway Age Gazette*, September 19, page 502.

#### Bureau of Railway Economics.

On August 1, 1910, sixty of the principal railways of the United States established the Bureau of Railway Economics, for the exclusive purpose of gathering and furnishing to the railways comprehensive, accurate and impartial information in regard to economic questions of interest to them in common. The bureau was placed under the supervision of a general executive committee consisting of W. C. Brown (New York Central); W. W. Finley (Southern); Darius Miller (Burlington); E. P. Ripley (Santa Fe); Daniel Willard (B. & O.), and B. L. Winchell, now traffic director of the Union Pacific. The office of the bureau was established at Washington to be near the records of the Interstate Commerce Commission and other governmental departments. At the invitation of this committee the members of the bureau held a meeting at its office in Washington on Friday last, October 17, for the purpose of inspecting its quarters, reviewing its work, and discussing its future. Thirty railway companies were represented by their presidents or vice-presidents. L. E. Johnson, president of the Norfolk & Western, was elected chairman of the meeting, and J. C. Williams, assistant to the president of the Southern Railway, secretary.

In reply to queries, L. G. McPherson, director of the bureau, analyzed its expenditures and made a presentation showing the extent to which its compilations are used by the railways, by educational institutions, the railway commissions, legislative bodies and the general press throughout the United States; also by official ministries and others concerned in transportation questions in foreign countries.

Speeches commending the work of the bureau in supplying accurate and unbiased information for the use of the railways regarding important phases of their economic relations, and emphasizing the necessity for the continuance of such work were made by Messrs. Samuel Rea, W. C. Brown, E. P. Ripley, Frank Trumbull, C. S. Sims, Ralph Peters, W. W. Finley, L. E. Johnson and others. A suggestion that the bureau be incorporated into the American Railway Association was thoroughly discussed; but the proposition was found not to be feasible at any time in the near future.

It was resolved that, to give the bureau continually the benefit of minds coming afresh to its affairs, three members of the general executive committee, one from the East, one from the West, and one from the South should be succeeded each year by three new members, from the same sections, respectively.

A nomination committee, composed of Messrs. Trumbull, Ripley and Brown, suggested Messrs. Samuel Rea, L. E. Johnson and Fairfax Harrison as the new members. The general executive committee for the ensuing year was thereupon elected. It is composed of Samuel Rea, president of the Pennsylvania Railroad, chairman; L. E. Johnson, president of the Norfolk & Western; Daniel Willard, president of the Baltimore & Ohio; Darius Miller, president of the Chicago, Burlington & Quincy; Fairfax Harrison, president of the Chicago, Indianapolis & Louisville, and B. L. Winchell, traffic director of the Union Pacific.

#### B. & B. Supply Association.

The Bridge and Building Supply Men's Association prepared an exhibit in the parlors adjoining the convention hall. Thirty-one firms were represented, the exhibits consisting in large part of photographs, literature and samples, because of the difficulty of bringing larger exhibits from the United States into Canada.

The officers of this association for the past year were: President, H. Henning, Eastern Granite Roofing Company; first vice-president, J. A. Meaden, Paul Dickinson, Inc.; treasurer, D. A. Bonitz, National Roofing Company; secretary, H. A. Neally, Joseph Dixon Crucible Company. At the annual meeting of the association held on Tuesday morning, the following officers were elected for the ensuing year: President, J. A. Meaden; vice-president, D. A. Bonitz; treasurer, H. A. Neally; secretary, L. D. Mitchell, Detroit Graphite Company; members of executive committee, C. E. Ward, U. S. Wind Engine & Pump Company, Batavia, Ill., and W. A. Hemenway, Asphalt Ready Roofing Company, New York.

The following firms were represented:

- American Hoist and Derrick Company, St. Paul, Minn.—Model of American ditcher and photographs. Represented by F. J. Johnson and W. O. Washburn.
- Asphalt Ready Roofing Company, New York.—Samples of roofing and asphalt shingles. Represented by H. H. Husted and W. A. Hemenway.
- American Track Barrow Company, The, Lowell, Mass.—Track barrows, lumber dollies and material boxes. Represented by E. B. Peirce.
- American Valve and Meter Company, The, Cincinnati, Ohio. Represented by J. T. McGarry.
- Barrett Manufacturing Company, New York.—Literature. Represented by H. B. Nichols and G. K. Dearborn.
- Buda Company, The, Chicago.—Literature and photographs of motor cars. Represented by G. A. Glasford.
- Carey Company, Philip, Cincinnati, Ohio.—Samples of waterproofing and photographs. Represented by W. F. T. Cheesman, A. Wallace and Wm. Ignatius.
- Chicago Bridge and Iron Works, Chicago.—Photographs and literature. Represented by M. J. Trees and K. I. Small.
- Chicago Pneumatic Tool Company, Chicago.—Drills of various types; motor cars. Represented by C. E. Walker, J. McCabe, Thos. Aldcorn and A. Allen.
- Clapp Fire Resisting Paint Company, Bridgeport, Conn. Represented by W. A. Clapp.
- Detroit Graphite Company, Detroit, Mich.—Literature. Represented by L. D. Mitchell and Wm. Bates.
- Dickinson, Paul, Inc., Chicago.—Literature and models of smoke jacks, chimneys and ventilators. Represented by A. J. Filkins and J. A. Meaden.
- Dixon Crucible Company, Joseph, Jersey City, N. J.—Photographs and literature. Represented by H. A. Neally and L. M. Chase.
- Eastern Granite Roofing Company, New York. Represented by I. H. Henning.
- Fairbanks, Morse & Company, Chicago.—Literature. Represented by A. A. Taylor, Geo. J. Akers, J. L. Jones and F. M. Condit.
- Forest City Paint and Varnish Company, Cleveland, Ohio. Represented by W. B. Wood.
- Heath & Milligan Company, Chicago. Represented by W. S. Mellen and W. H. Pratt.
- Johns-Manville Co., H. W., New York. Represented by W. H. Lawrence, P. C. Jacobs, R. A. Hamaker, H. L. Leach and J. E. Meek.
- Lehon Company, The, Chicago.—Samples of roofing and literature. Represented by Tom Lehon.
- Mudge & Company, Burton W., Chicago.—Mudge-Adams motor car. Represented by J. C. Donnelly and J. P. O'Reilly.
- National Roofing Company, Tonawanda, N. Y.—Samples of roofing. Represented by D. A. Bonitz and C. A. Sullivan.
- Patterson Company, W. W., Pittsburgh, Pa. Represented by W. W. Patterson, Jr.
- Pedlar People, Limited, The, Oshawa, Ont.—Sample 24 in. Toncan metal corrugated culvert. Represented by A. T. Enlon and W. E. Ramsay.
- Richards-Wilcox Manufacturing Company, Aurora, Ill., and London, Ont.—Door hardware. Represented by W. D. Jameson.

Standard Asphalt and Rubber Company, Chicago.—Photographs, literature and samples of waterproofing. Represented by I. B. Patterson and G. V. Eddes.

Templeton, Kenly & Company, Chicago.—Simplex jacks. Represented by Alfred E. Barron and Arthur C. Lewis.

Texas Company, The, Houston, Tex. Represented by W. E. O'Neill and W. E. Greenwood.

U. S. Wind Engine and Pump Company, Batavia, Ill.—Literature. Represented by C. E. Ward.

Wadsworth-Howland Company, Chicago. Represented by E. E. Allen.  
Webb Manufacturing Company, F. W., Boston, Mass.—Samples of unions. Represented by Geo. H. Ayer.

#### American Electric Railway Association.

The thirty-second annual convention of the American Electric Railway Association and its allied and affiliated bodies, the American Electric Railway Accountants' Association, the American Electric Railway Engineering Association, the American Electric Railway Claims Association and the American Electric Railway Transportation and Traffic Association was held in Atlantic City, N. J., on October 13, 14, 15, 16 and 17. The attendance was about the same as that at the thirtieth annual convention held in Atlantic City in 1911, but was smaller than that of last year, when the convention was held at Chicago. A number of important reports and individual papers were presented before each of the associations, the meetings of all of which were well attended, even though the sessions were often of considerable length. The address of President George H. Harries, of the American Electric Railway Association was specially noteworthy, because of the comprehensive way in which it summed up the vital problems now confronting the street railways. Charles N. Black, vice-president and general manager of the United Railroads of San Francisco, was elected to the presidency for the ensuing year.

The exhibit of the Manufacturers' Association required the maximum amount of space available for this purpose on the Million Dollar Pier. Cornell S. Hawley, president of the Laconia Car Company, was elected president of the Manufacturers' Association.

#### Railway Electrical Engineers' Convention.

The following supply firms made exhibits at the sixth annual convention of the Association of Railway Electrical Engineers, held in Chicago, October 20-24. An account of the convention will be found elsewhere in this issue:

Adams & Westlake Company, American Pulley Company, Appleton Electric Company, Benjamin Electric & Manufacturing Company, Central Electric Company, Crouse-Hinds Company, Cutter Electric & Manufacturing Company, Economy Fuse & Manufacturing Company, Edison Storage Battery Company, Electric Storage Battery Company, Electrical Testing Laboratories, General Electric Company, George Cutter Company, Gould Coupler Company, Hess Bright Manufacturing Company, Kerite Insulated Wire & Cable Company, Main Belting Company, National Metal Molding Company, National Electric Lamp Association, National X-Ray Reflector Company, Norma Company of America, Oneida Steel Pulley Company, Phillips Manufacturing Company, Pyle-National Electric Headlight Company, Railway Electrical Engineer, Remy Electric Company, Safety Car Heating & Lighting Company, Sangamo Electric Company, S. K. F. Ball Bearing Company, U. S. Light & Heating Company, Western Electric Company, Westinghouse Electric & Manufacturing Company, Westinghouse Lamp Company, Weston Electrical Instrument Company, Willard Storage Battery Company.

#### Meeting of New York Railroad Club.

At the meeting held on the evening of Friday, October 17, George L. Norris, engineer of tests, American Vanadium Company, presented a paper on Vanadium steel in locomotive construction. The paper was illustrated by lantern slides. Curves were presented showing the increasing use of Vanadium steel in locomotives during the past five years. At the present time 12 per cent. of the locomotives being built have Vanadium steel specified for some of their parts. A brief history of the discovery and use of Vanadium was given and illustrations of the various locomotive parts for which it is now being used were shown, most of them in the form of full size parts that had been subjected to tests. Tables of the chemical and physical properties of the material were given. Most of the matter of this

kind given in the paper has already been published in these columns. The paper also included recommended specifications of Vanadium steel locomotive parts. The importance of proper heat treatment was specially mentioned by the author. The paper for the November meeting will be by Daniel M. Brady, president of the Brady Brass Company, on the subject of Railroad Clubs. An invitation has been extended to the officers of all other railroad clubs to be present and discuss this subject. This meeting will be held on November 21 at the Engineering Society's building, 239 West Thirty-ninth street, New York.

#### Railroad Surgeons.

The tenth annual meeting of the American Association of Railway Surgeons was held at the Hotel Sherman, Chicago, on October 15, 16 and 17. Dr. S. C. Plummer, chief surgeon of the Rock Island Lines, in his opening address as president spoke on the subject of "Safety First." Other speakers included Dr. R. A. Douglas, surgeon of the Atchison, Topeka & Santa Fe at Collinsville, Okla., Dr. John B. Murphy of Chicago, and George H. Whittle, president of the Public Safety Committee of the city of Chicago. Officers were elected as follows: President, Dr. D. S. Fairchild, Clinton, Ia.; first vice-president, Dr. E. S. Judd, Rochester, Minn.; second vice-president, Dr. I. L. Parsens, Brookhaven, Miss.; executive board, Dr. S. C. Plummer, Chicago; Dr. D. Y. Roberts, Louisville, Ky.; treasurer, H. B. K. Jennings, Council Bluffs, Ia.; secretary-editor, Louis J. Mitchell, Chicago.

#### General Passenger Agents.

The American Association of General Passenger and Ticket Agents at its annual meeting in Philadelphia last week, elected officers for the ensuing year as follows: President, W. J. Craig, passenger traffic manager of the Atlantic Coast Line; vice-president, Gerrit Fort, passenger traffic manager of the Union Pacific; secretary, W. C. Hope, general passenger agent of the Central of New Jersey, New York City.

#### MEETINGS AND CONVENTIONS.

*The following list gives names of secretaries, dates of next or regular meetings, and places of meeting.*

- AIR BRAKE ASSOCIATION.—F. M. Nellis, 53 State St., Boston, Mass. Next convention, May, 1914.
- AMERICAN ASSOCIATION OF DEMURRAGE OFFICERS.—A. G. Thomason, Boston, Mass. Convention, May 19, 1914, St. Louis.
- AMERICAN ASSOCIATION OF GENERAL PASSENGER AND TICKET AGENTS.—W. C. Hope, New York. Annual meeting, October 14-15, Philadelphia, Pa.
- AMERICAN ASSOCIATION OF FREIGHT AGENTS.—R. O. Wells, East St. Louis, Ill. Next convention, April 21, Houston, Tex.
- AMERICAN ASSOCIATION OF RAILROAD SUPERINTENDENTS.—E. H. Harman, St. Louis, Mo.; 3d Thursday and Friday in May.
- AMERICAN ELECTRIC RAILWAY ASSOCIATION.—H. C. Donecker, 29 W. 39th St., New York.
- AMERICAN ELECTRIC RAILWAY MANUFACTURERS' ASSOC.—H. G. McConaughy, 165 Broadway, New York. Meetings with Am. Elec. Ry. Assoc.
- AMERICAN RAILWAY ASSOCIATION.—W. F. Allen, 75 Church St., New York. Next meeting, November 19, 1913, Chicago.
- AMERICAN RAILWAY BRIDGE AND BUILDING ASSOCIATION.—C. A. Lichty, C. & N. W., Chicago.
- AMERICAN RAILWAY ENGINEERING ASSOCIATION.—E. H. Fritch, 900 S. Michigan Ave., Chicago. Next convention, March 17-20, Chicago.
- AMERICAN RAILWAY MASTER MECHANICS' ASSOCIATION.—J. W. Taylor, Old Colony building, Chicago.
- AMERICAN RAILWAY TOOL FOREMEN'S ASSOCIATION.—A. R. Davis, Central of Georgia, Macon, Ga.
- AMERICAN SOCIETY FOR TESTING MATERIALS.—Prof. E. Marburg, University of Pennsylvania, Philadelphia, Pa.
- AMERICAN SOCIETY OF CIVIL ENGINEERS.—C. W. Hunt, 220 W. 57th St., New York; 1st and 3d Wed., except June and August, New York.
- AMERICAN SOCIETY OF ENGINEERING CONTRACTORS.—J. R. Wenlinger, 11 Broadway, New York; 2d Tuesday of each month, New York.
- AMERICAN SOCIETY OF MECHANICAL ENGINEERS.—Calvin W. Rice, 29 W. 39th St., New York.
- AMERICAN WOOD PRESERVERS' ASSOCIATION.—F. J. Angier, B. & O., Baltimore, Md. Next convention, January 20-22, 1914, New Orleans, La.
- ASSOCIATION OF AMERICAN RAILWAY ACCOUNTING OFFICERS.—C. G. Phillips, 143 Dearborn St., Chicago. Annual meeting, May 28, Atlantic City, N. J.
- ASSOCIATION OF RAILWAY CLAIM AGENTS.—C. W. Egan, B. & O., Baltimore, Md. Next convention, May, 1914, St. Paul, Minn.
- ASSOCIATION OF RAILWAY ELECTRICAL ENGINEERS.—Jos. A. Andreucetti, C. & N. W. Ry., Chicago. Annual convention, October 18-24, Chicago.
- ASSOCIATION OF RAILWAY TELEGRAPH SUPERINTENDENTS.—P. W. Drew, 112 West Adams St., Chicago. Next convention, May 20-23, New Orleans, La.
- ASSOCIATION OF TRANSPORTATION AND CAR ACCOUNTING OFFICERS.—G. P. Conard, 75 Church St., New York. Next meeting, December 9-10, Galveston, Tex.

## Traffic News.

**ASSOCIATION OF WATER LINE ACCOUNTING OFFICERS.**—W. R. Evans, Chamber of Commerce, Buffalo, N. Y.

**BRIDGE AND BUILDING SUPPLY MEN'S ASSOCIATION.**—H. A. Neally, Joseph Dixon Crucible Co., Jersey City, N. J. Meeting with American Railway Bridge and Building Association.

**CANADIAN RAILWAY CLUB.**—James Powell, Grand Trunk Ry., Montreal, Que.; 2d Tuesday in month, except June, July and Aug., Montreal.

**CANADIAN SOCIETY OF CIVIL ENGINEERS.**—Clement H. McLeod, 413 Dorchester St., Montreal, Que.; Thursday, Montreal.

**CAR FOREMEN'S ASSOCIATION OF CHICAGO.**—Aaron Kline, 841 North 50th Court, Chicago; 2d Monday in month, Chicago.

**CENTRAL RAILWAY CLUB.**—H. D. Vought, 95 Liberty St., New York; 2d Thurs. in Jan. and 2d Fri. in March, May, Sept., Nov., Buffalo, N. Y.

**CIVIL ENGINEERS' SOCIETY OF ST. PAUL.**—L. S. Pomeroy, Old State Capitol building, St. Paul, Minn.; 2d Monday, except June, July, August and September, St. Paul.

**ENGINEERS' SOCIETY OF PENNSYLVANIA.**—E. R. Dasher, Box 704, Harrisburg, Pa.; 1st Monday after second Saturday, Harrisburg, Pa.

**ENGINEERS' SOCIETY OF WESTERN PENNSYLVANIA.**—E. K. Hiles, Oliver building, Pittsburgh; 1st and 3d Tuesday, Pittsburgh, Pa.

**FREIGHT CLAIM ASSOCIATION.**—Warren F. Taylor, Richmond, Va. Next convention, May 20-22, Galveston, Tex.

**GENERAL SUPERINTENDENTS' ASSOCIATION OF CHICAGO.**—E. S. Koller, 226 W. Adams St., Chicago; Wed. preceding 3d Thurs., Chicago.

**INTERNATIONAL RAILWAY CONGRESS.**—Executive Committee, 11, rue de Louvain, Brussels, Belgium. Convention, 1915, Berlin.

**INTERNATIONAL RAILWAY FUEL ASSOCIATION.**—C. G. Hall, 922 McCormick building, Chicago. Annual convention, May 18-22, Chicago.

**INTERNATIONAL RAILWAY GENERAL FOREMEN'S ASSOCIATION.**—Wm. Hall, 829 West Broadway, Winona, Minn. Next convention, July, Chicago.

**INTERNATIONAL RAILROAD MASTER BLACKSMITHS' ASSOCIATION.**—A. L. Woodworth, Lima, Ohio. Next convention, third Tuesday in August.

**MAINTENANCE OF WAY & MASTER PAINTERS' ASSOCIATION OF THE UNITED STATES AND CANADA.**—W. G. Wilson, Lehigh Valley, Easton, Pa. Next convention, November 18-20, Louisville, Ky.

**MASTER BOILER MAKERS' ASSOCIATION.**—Harry D. Vought, 95 Liberty St., New York.

**MASTER CAR BUILDERS' ASSOCIATION.**—J. W. Taylor, Old Colony building, Chicago.

**MASTER CAR & LOCOMOTIVE PAINTERS' ASSOC. OF U. S. AND CANADA.**—A. P. Dane, B. & M., Reading, Mass.

**NATIONAL RAILWAY APPLIANCE ASSOC.**—Bruce V. Crandall, 537 So. Dearborn St., Chicago. Meetings with Am. Ry. Eng. Assoc.

**NEW ENGLAND RAILROAD CLUB.**—W. E. Cade, Jr., 683 Atlantic Ave., Boston, Mass.; 2d Tuesday in month, except June, July, Aug. and Sept., Boston.

**NEW YORK RAILROAD CLUB.**—H. D. Vought, 95 Liberty St., New York; 3rd Friday in month, except June, July and August, New York.

**NORTHERN RAILROAD CLUB.**—C. L. Kennedy, C. M. & St. P., Duluth, Minn.; 4th Saturday, Duluth.

**PEORIA ASSOCIATION OF RAILROAD OFFICERS.**—M. W. Rotchford, Union Station, Peoria; 2d Thursday.

**RAILROAD CLUB OF KANSAS CITY.**—C. Manlove, 1008 Walnut St., Kansas City, Mo.; 3d Friday in month, Kansas City.

**RAILWAY BUSINESS ASSOCIATION.**—Frank W. Noron, 2 Rector St., New York. Annual dinner, second week in December, 1913, New York.

**RAILWAY CLUB OF PITTSBURGH.**—J. B. Anderson, Penns R. R., Pittsburgh, Pa.; 4th Friday in month, except June, July and August, Pittsburgh.

**RAILWAY ELECTRICAL SUPPLY MANUFACTURERS' ASSOC.**—J. Scribner, 1021 Monadnock Block, Chicago. Meetings with Assoc. Ry. Elec. Engrs.

**RAILWAY FIRE PROTECTION ASSOCIATION.**—C. B. Edwards, Mobile & Ohio, Mobile, Ala.

**RAILWAY GARDENING ASSOCIATION.**—J. S. Butterfield, Lee's Summit, Mo.

**RAILWAY DEVELOPMENT ASSOCIATION.**—W. Nicholson, Kansas City Southern, Kansas City, Mo. Next meeting, November 11-12, Baltimore, Md.

**RAILWAY SIGNAL ASSOCIATION.**—C. C. Rosenberg, Bethlehem, Pa.

**RAILWAY STOREKEEPERS' ASSOCIATION.**—J. P. Murphy, Box C, Collinwood, Ohio.

**RAILWAY SUPPLY MANUFACTURERS' ASSOC.**—J. D. Conway, 2135 Oliver bldg., Pittsburgh, Pa. Meetings with M. M. and M. C. B. Assocs.

**RAILWAY TEL. & TEL. APPLIANCE ASSOC.**—W. E. Harkness, 284 Pearl St., New York. Meetings with Assoc. of Ry. Teleg. Sups.

**RICHMOND RAILROAD CLUB.**—F. O. Robinson, Richmond, Va.; 2d Monday except June, July and August.

**ROADMASTERS' AND MAINTENANCE OF WAY ASSOCIATION.**—L. C. Ryan, C. & N. W., Sterling, Ill.

**ST. LOUIS RAILWAY CLUB.**—B. W. Frauenthal, Union Station, St. Louis, Mo.; 2d Friday in month, except June, July and Aug., St. Louis.

**SIGNAL APPLIANCE ASSOCIATION.**—F. W. Edmonds, 3868 Park Ave., New York. Meeting with annual convention Railway Signal Association.

**SOCIETY OF RAILWAY FINANCIAL OFFICERS.**—C. Nyquist, La Salle St. Station, Chicago.

**SOUTHERN ASSOCIATION OF CAR SERVICE OFFICERS.**—E. W. Sandwich, A. & W. P. Ry., Montgomery, Ala.

**SOUTHERN & SOUTHWESTERN RAILWAY CLUB.**—A. J. Merrill, Grant bldg., Atlanta, Ga.; 3d Thurs., Jan., March, May, July, Sept., Nov., Atlanta.

**TOLEDO TRANSPORTATION CLUB.**—J. G. Macomber, Woolson Spice Co., Toledo, Ohio; 1st Saturday, Toledo.

**TRACK SUPPLY ASSOCIATION.**—W. C. Kidd, Ramapo Iron Works, Hillsburn, N. Y. Meetings with Roadmasters' and Maintenance of Way Association.

**TRAFFIC CLUB OF CHICAGO.**—W. H. Wharton, La Salle Hotel, Chicago.

**TRAFFIC CLUB OF NEW YORK.**—C. A. Swope, 290 Broadway, New York; 1st Tuesday in month, except June, July and August, New York.

**TRAFFIC CLUB OF PITTSBURGH.**—D. L. Wells, Erie, Pittsburgh, Pa.; meetings monthly, Pittsburgh.

**TRAFFIC CLUB OF ST. LOUIS.**—A. F. Versen, Mercantile Library building, St. Louis, Mo. Annual meeting in November. Noonday meetings October to May.

**TRAIN DESPATCHERS' ASSOCIATION OF AMERICA.**—J. F. Mackie, 7122 Stewart Ave., Chicago. Next convention, June 16, Jacksonville, Fla.

**TRANSPORTATION CLUB OF BUFFALO.**—J. M. Sells, Buffalo; first Saturday after first Wednesday.

**TRANSPORTATION CLUB OF DETROIT.**—W. R. Hurley, L. S. & M. S., Detroit, Mich.; meetings monthly.

**TRAVELING ENGINEERS' ASSOCIATION.**—W. O. Thompson, N. Y. C. & H. R., East Buffalo, N. Y. Next meeting, Chicago.

**UTAH SOCIETY OF ENGINEERS.**—Fred D. Ulmer, Oregon Short Line, Salt Lake City, Utah; 3rd Friday of each month, except July and August.

**WESTERN CANADA RAILWAY CLUB.**—W. H. Rosevear, P. O. Box 1707, Winnipeg, Man.; 2d Monday, except June, July and August, Winnipeg.

**WESTERN RAILWAY CLUB.**—J. W. Taylor, Old Colony building, Chicago; 3d Tuesday of each month, except June, July and August.

**WESTERN SOCIETY OF ENGINEERS.**—J. H. Warder, 1735 Monadnock Block, Chicago; 1st Monday in month, except July and August, Chicago.

The railroads of Canada have all given notice that, beginning with next January, all arrangements for giving free cartage of freight to and from freight houses will be discontinued.

Railways in the Southwestern Passenger Association, with the exception of the St. Louis Southwestern, have announced that interchangeable mileage books at a rate of 2½ cents a mile will be put on sale in Louisiana and Texas on January 1.

The Chicago & North Western, in co-operation with the Iowa Beef Producers' Association and the Iowa Agricultural College is running a special demonstration and instruction train, known as the "Beef Production Special," over its lines in Iowa.

Representatives of the chambers of commerce of Detroit, Buffalo, Pittsburgh, Cleveland, Toledo, Springfield, Columbus and Cincinnati met recently in the last-named city to discuss freight rates between the various cities with a view to securing readjustments.

B. L. Winchell, director of traffic of the Union Pacific, has announced that new freight service over the Union Pacific system from Kansas City to the Pacific coast via the cut-off from Topeka to Marysville, to be put into effect within two weeks, will reduce the time by 20 hours.

Seven railways in Nebraska have filed with the state railroad commission notice of an appeal to the Supreme Court of the state from the recent decision of the commission reducing freight rates on apples, peaches and pears in carloads. The roads have announced that the new rates will be made effective pending the decision of the court.

Minnesota railways running into North Dakota have announced that beginning November 1, passenger fares between points in the two states will be made on the basis of two cents a mile as a result of the reduction to two cents in Minnesota. Since the decision of the Supreme Court in the Minnesota case, the roads have continued to charge three cents a mile for interstate tickets.

The Chicago, Burlington & Quincy has recently installed through dining car service on its trains to the North Pacific coast. The dining cars and their crews will run through to the coast without change, instead of changing cars and employees at the various points. In the event of any delay, therefore, the passengers will have an assurance of food supply, because the dining car will be a regular part of the train.

The Western Classification Committee announces that the docket for the January 13, 1914, meeting will close on November 10, and that no petitions filed after that date can be included in the docket to receive consideration at the meeting. This is made necessary by the fact that at least 30 days is required for the investigation of petitions and the compilation, printing and distribution of the docket, which is intended to be in the hands of shippers from 15 to 30 days in advance of the meeting.

The Salt Lake City Transportation Club has recently elected the following officers: President, J. H. Davis, general agent, Colorado Midland; vice-presidents, S. V. Derrah, assistant general freight agent, Denver & Rio Grande; W. R. Armstrong, assistant general agent, S. L. & U.; J. A. Reeves, general freight agent, Oregon Short Line; A. W. Griggs, chief clerk to auditor, Oregon Short Line; secretary, R. E. Rowland, secretary Intermountain Demurrage Bureau; treasurer, C. E. Flandro, soliciting freight agent, Union Pacific.

### Forcing Merchants to Buy More Goods Than They Want.

While the average capacity of freight cars has increased 9.18 tons, or 33.46 per cent., the average number of tons of revenue freight per loaded car has increased only 3.47 tons, or 21.36 per cent., in the last decade. Over 62 per cent. of the increased capacity has not been used in practice. Shippers whose business has been disturbed by periodical increases in minimum carload weight requirements are disposed to complain because the railroads disregard commercial conditions, which demand the small carload unit; and the railroad traffic managers, pressed on one side by their operating and executive officers to get bigger loads



for the bigger cars, and on the other hand meeting the protest of shippers against further increase in the minimum weight conditions of the tariffs, are discouraged and almost desperate.

Railroad managers fail to recognize that commercial conditions govern the size of carloads. Increased loading per car often means increased expense for the shipper. The extra cost of loading barrels two tiers deep in the cars, the extra labor and cost of working into it the last 2,000 or 3,000 ft. of lumber necessary to fill a car, the extra cost of stakes and fastenings for big loads on flat cars ought to be considered.

The attitude of shippers toward the big carload may depend largely on the way in which the merchandise is bought and sold—whether sold by a man who has a large quantity to sell or bought by a man who wants a large or small quantity; on the desire of the retail merchant to get the minimum carload of flour because of the original investment, interest and insurance, cost of carrying the stock, depreciation in quality, chance of a falling market, etc., and the same thing is true of sugar, beans, and everything in the list of goods handled by small shippers or large retailers. Rates graduated according to size of car would effect a decided economy.—*Wall Street Journal*.

**Car Shortage—An Appeal from the Government.**

The Interstate Commerce Commission has issued a circular announcing that informal complaints received by it indicate that the annually recurring car shortage is again appearing. The Commission urges on all shippers and all carriers close attention to loading, unloading, moving, and promptly returning cars.

"In order that the business of the country may go forward without interruption, the Commission urges shippers, both individually and through their associations, to co-operate to secure the prompt and full loading of cars and their prompt release. One of the chief causes of failure of car supply in past seasons has been the unnecessary detention of cars by careless shippers and by shippers using them for storage purposes. In the general public interest, shippers should endeavor to release cars at the earliest possible moment without regard to the free time given by the tariffs. Carriers also must use extraordinary measures to eliminate all delays chargeable to them. The failure of car supply is usually a failure of car movement. The congestion of terminals is the ever present feature at times of such failure. The Commission therefore urges carriers to make every possible endeavor to improve their methods of operation of terminals in order that cars may move promptly. Company material should be unloaded with the same despatch that is required of shippers.

"The Commission is moved to make this appeal by its desire to save both shippers and carriers from the losses which are occasioned by failures of car supply, and by its knowledge that measures such as are here suggested have operated in past seasons to save all concerned from heavy losses."

**Car Location.**

The accompanying table, which was taken from bulletin No. 10-A of the American Railway Association, gives a summary of freight car location by groups on September 15, 1913.

	CAR LOCATION ON SEPTEMBER 15, 1913.											Grand Total
	New England	N.Y., Del., Md., Pa.	N.J., Mich., Pa.	Ohio, Western Pa.	Ind., W. Va., No. & So. Carolina.	Va., Ky., Ala., Ga., Fla.	Tenn., Miss., Ala., Fla.	Iowa, Ill., Wis., Minn.	Mont., Wyo., Neb., Dakotas.	Kans., Colo., Mo., Ark.	Texas, La., New Mexico.	
Total Cars Owned	88,167	682,387	273,522	203,334	171,622	478,067	19,265	157,229	31,117	133,608	140,319	1,085,478
Home Cars on Home Roads	43,814	383,535	96,985	105,458	84,068	327,907	7,215	82,362	13,430	76,554	96,193	1,317,441
Home Cars on Foreign Roads	44,353	298,852	176,617	97,876	87,554	150,160	12,050	74,867	17,687	57,054	44,126	1,061,196
Foreign Cars on Home Roads	51,276	292,359	199,292	72,815	71,922	190,686	10,131	74,111	28,270	56,240	38,376	1,095,478
Total Cars on Line	95,090	675,894	296,197	178,273	155,990	518,593	17,346	156,473	41,700	132,794	134,569	2,402,919
Excess or Deficiency	6,923	*6,493	22,675	*25,061	*15,632	40,526	*1,919	*756	10,583	*814	*5,750	24,282
Surplus	549	3,436	615	3,952	1,434	11,246	927	9,219	3,258	13,090	14,027	61,753
Shortage	218	1,944	3,912	6,821	3,354	2,846	195	347	110	672	1,175	21,594
Shop Cars—												
Home Cars in Home Shops	6,682	40,649	21,224	14,029	15,542	25,172	615	12,494	2,437	5,204	6,459	150,507
Foreign Cars in Home Shops	1,182	8,526	7,340	1,872	1,842	5,543	470	3,117	946	2,226	416	33,480
Total Cars in Shops	7,864	49,175	28,564	15,901	17,384	30,715	1,085	15,611	3,383	7,430	6,875	183,987
Per Cent. to Total Cars Owned—												
Home Cars on Home Roads	49.69	56.20	35.43	51.86	48.98	68.59	37.45	52.38	43.16	57.30	68.55	55.39
Total Cars on Line	105.44	99.05	108.19	87.67	90.89	108.48	90.04	98.87	134.01	99.39	95.90	101.02
Home Cars in Home Shops	7.58	5.96	7.76	6.90	9.06	5.60	3.19	7.95	7.83	3.89	4.60	6.33
Foreign Cars in Home Shops	.98	1.25	2.68	.92	1.07	1.23	2.44	1.87	3.04	1.67	.30	1.40
Total Cars in Shops	8.56	7.21	10.44	7.82	10.13	6.83	5.63	9.82	10.87	5.56	4.90	7.73

\*Denotes deficiency.

**INTERSTATE COMMERCE COMMISSION.**

Examiner Marshall of the Interstate Commerce Commission, held a hearing in Kansas City on October 20, on a proposed advance in rates on bananas and other tropical fruits shipped from the Gulf of Mexico to Kansas and Nebraska points.

The Commission has further suspended from October 29 until April 29 the operation of certain schedules in tariffs, advancing from 1 to 3 cents per 100 lbs. commodity rates on sulphate of potash, manure salts, etc., from Baltimore, Md., and other Eastern points to Cincinnati and other points, as issued by the Baltimore & Ohio and other Eastern roads.

The commission has suspended from October 21 until April 21, certain schedules in Agent F. A. Leland's tariff, which proposed to advance rates for the transportation of lumber and articles taking lumber rates from Texas points to stations in Oklahoma, Kansas and Missouri, including Kansas City, on the line of the Atchison, Topeka & Santa Fe, north of Tulsa, Okla.

The Commission has suspended from November 2 until January 30 the operation of certain schedules in Supplement No. 28 to Agent F. A. Leland's tariff I. C. C. No. 930, by which it was proposed to advance rates on cottonseed hulls from Beaumont, Tex., and other points to New Orleans and other points in Louisiana, located on the New Orleans, Texas & Mexico.

The Commission has suspended from October 21 until February 18 the operation of Item No. 2118a of Agent F. A. Leland's Supplement No. 10 to I. C. C. No. 978, and Agent Eugene Morris' Supplement No. 10 to I. C. C. No. 391. It was proposed by the suspended item to increase rates on salt from points east of the Mississippi river to points in Louisiana.

The commission has suspended from October 10 until February 7 the operation of Agent W. H. Hosmer's supplement which proposed to effect advances ranging in amount from 1/2 cent to 3 cents per 100 lbs. in rates for the transportation of linseed oil, C. L., from Minneapolis, Minn., and points taking same rates to points in Central Freight Association territory. For example, the present rate from the above-mentioned points to Cincinnati, Ohio, is 27 cents per 100 lbs., and the proposed rate is 30 cents per 100 lbs. C. L.

The commission has extended the effective date of the order in the Express Rate cases from October 15, 1913, to December 1, 1913. The commission declines to revise the scale. Upon showing that further time for preparation of tariffs is necessary and that work is being prosecuted with diligence, application for further extension will have consideration by the commission. As to commodity rates, application for extension of time as to particular named tariffs with statement of difficulties, will have consideration by the commission.

**A Few Advances.**

The commission has issued a decision allowing increases in certain commodity rates between Missouri river points, Kansas City, Omaha, St. Joseph and Sioux City. It is held that

REVENUES AND EXPENSES OF RAILWAYS.

MONTH OF AUGUST, 1913.

Name of road.	Average mileage operated during period.		Operating revenues.		Maintenance of way and equipment.		Operating expenses.			Net operating revenue (or deficit).	Outside operations, net.	Taxes.	Operating income (or loss).	Increase (or decr.) comp. with last year.
	Freight.	Passenger.	Total, inc. mch.	Total.	Structures.	Equipment.	Traffic.	Trans- portation.	General.					
Chicago & Eastern Illinois	1,282	\$1,033,455	\$306,570	\$1,454,186	\$290,753	\$334,508	\$20,977	\$512,550	\$9,827	\$1,198,572	\$235,614	\$3,124	\$207,490	-\$121,857
Lehigh & New England	269	135,204	2,548	141,721	22,559	20,924	1,552	35,956	3,469	84,466	57,261	.....	3,179	21,738
New Orleans, Texas & Mexico	286	106,984	18,646	133,546	15,478	15,478	3,348	50,874	7,361	103,704	29,842	.....	1,432	16,717
Oahu Ry. & Land Co.	101	93,906	26,987	128,635	8,708	7,546	563	23,477	4,980	45,274	83,361	-2,864	6,580	-9,800
Ulster & Delaware	129	60,105	72,920	139,648	17,069	13,184	1,912	53,064	3,168	88,397	51,251	-78	3,500	-5,398
TWO MONTHS OF FISCAL YEAR, 1914.														
Chicago & Eastern Illinois	1,282	\$2,025,945	\$575,313	\$2,821,758	\$37,451	\$620,012	\$43,002	\$984,985	\$77,518	\$2,262,968	\$558,790	-\$5,599	\$90,000	-\$227,764
Lehigh & New England	269	267,178	3,387	278,967	44,713	42,426	3,008	71,888	6,665	168,700	110,267	.....	6,358	-31,861
New Orleans, Texas & Mexico	286	203,213	37,614	256,528	51,545	24,016	6,507	95,733	13,730	191,551	64,997	.....	2,866	24,081
Oahu Ry. & Land Co.	101	203,994	53,232	273,601	16,542	17,069	1,132	49,106	9,161	92,010	181,591	1,789	13,160	20,290
San Pedro, Los Angeles & Salt Lake	1,133	1,022,900	590,513	1,736,343	243,300	278,707	65,688	567,584	38,060	1,193,339	543,004	-2,828	83,900	-85,886
Seaboard	3,082	2,324,354	887,580	3,599,663	443,148	505,965	131,447	1,401,827	108,546	2,590,933	1,008,730	-3,422	164,000	61,324
Southern	7,037	6,713,891	3,588,334	11,090,233	1,617,436	1,844,057	360,264	3,907,993	321,687	8,051,437	3,038,796	1,006	417,073	-404,527
Southern in Mississippi	281	88,601	63,796	167,038	22,176	22,176	4,484	83,598	7,395	170,226	-3,188	.....	13,624	3,716
Southern Kansas of Texas	179	147,220	35,811	193,466	20,378	33,741	4,355	62,002	7,130	127,606	65,860	.....	7,949	-13,580
Southern Pacific Co.	6,381	9,107,256	5,861,968	16,201,584	1,801,784	2,336,206	320,708	4,424,799	467,663	9,351,160	6,850,224	263,711	802,633	-1,372,399
Spokane International	163	184,027	49,710	192,953	37,585	11,502	3,899	53,650	7,109	113,745	79,208	.....	6,040	-25,242
Spokane, Portland & Seattle	556	484,262	382,555	940,988	124,452	75,131	19,028	212,093	25,703	456,407	484,581	5,127	106,800	-34,063
Tennessee Central	294	192,475	87,559	295,552	58,189	24,402	11,443	97,066	14,334	205,434	90,118	.....	8,491	15,951
Terminal R. R. Ass'n of St. Louis	34	.....	484	471,829	81,591	44,632	1,740	172,916	11,657	312,536	159,293	13,761	53,200	-42,703
Texas & New Orleans	458	444,832	230,920	718,479	148,189	170,497	14,883	284,456	25,577	643,602	74,877	8,353	48,138	-67,725
Texas & Pacific	1,885	1,842,180	856,781	2,866,478	509,322	492,883	70,079	1,131,882	80,144	2,284,310	582,168	9,444	96,276	473,613
Toledo & Ohio Central	443	958,684	131,849	1,162,476	224,411	204,464	16,066	426,188	19,838	890,967	271,509	-1,517	40,621	-21,951
Toledo, Peoria & Western	248	128,908	95,888	237,880	49,342	57,295	4,966	97,179	7,242	216,024	111,856	.....	10,000	-31,800
Toledo, St. Louis & Western	451	692,954	88,796	830,488	84,029	113,860	30,940	279,411	17,448	525,688	304,800	.....	29,400	120,394
Trinity & Brazos Valley	463	253,346	115,916	383,316	101,439	74,747	21,916	188,992	22,862	409,956	-26,640	.....	8,000	-23,336
Ulster & Delaware	129	120,990	151,102	215,589	31,763	28,002	4,979	104,847	6,155	175,746	109,843	-155	7,000	-13,937
Union Pacific	3,611	6,025,584	2,132,142	8,989,432	1,003,427	1,186,053	219,553	2,246,153	245,428	4,900,614	4,088,818	-2,065	336,175	-492,717
Union R. R. of Baltimore	9	241,196	46,982	291,139	19,214	.....	2,727	11,268	5,100	38,309	252,830	.....	11,702	18,666
Union R. R. of Pennsylvania	31	.....	.....	986,195	100,733	189,115	209	346,674	5,038	641,769	344,426	7,441	20,000	-104,536
Vandalia	910	1,327,366	468,455	2,013,016	284,935	380,731	53,929	755,799	39,972	1,515,366	497,650	.....	60,632	7,015
Vicksburg, Shreveport & Pacific	171	165,298	108,351	294,676	51,801	56,461	6,805	102,902	10,079	228,048	66,628	-300	15,600	8,112
Virginia & Southwestern	240	284,146	36,578	329,045	44,674	74,592	4,453	90,299	7,597	219,615	109,430	.....	11,819	14,793
Virginian	503	910,418	79,417	1,018,690	128,847	181,745	10,685	230,964	18,158	570,399	448,291	14,362	42,120	86,937
Wabash	2,515	3,640,188	1,512,722	5,614,576	769,134	924,996	191,023	2,072,266	139,746	4,097,165	1,517,411	-7,379	148,895	-3,326
Washington Southern	36	74,239	73,875	199,635	26,011	28,315	2,486	82,178	5,870	144,860	54,775	-317	7,039	-16,049
West Jersey & Seashore	356	350,298	1,455,987	1,894,452	224,501	223,218	37,407	555,197	25,890	1,066,213	828,239	-6,464	54,603	-58,237
Western Maryland	661	1,122,878	294,509	1,482,322	233,516	194,606	46,909	602,964	31,698	1,109,693	372,629	.....	38,000	2,358
Western Pacific	934	899,576	315,188	1,245,060	227,165	114,891	55,658	395,189	65,941	858,844	386,216	1,513	59,333	75,742
Western Ry. of Alabama	133	102,146	92,148	211,743	44,241	49,003	11,508	65,079	10,962	180,793	30,950	-9	9,676	2,888
Wheeling & Lake Erie	459	1,343,785	141,337	1,558,736	321,248	294,524	16,842	475,931	33,232	1,141,777	416,959	-401	64,783	-182,653
Yazoo & Mississippi Valley	1,372	1,136,680	442,883	1,697,042	333,962	327,553	30,542	684,922	82,716	1,429,695	267,347	-2,792	86,000	123,508

the advanced rates will not result in excessive revenue to the railroad. The decision was written by Commissioner McChord, who pointed out that while the law casts upon the roads the burden of showing that the increased rates are reasonable, it is but fair that parties at whose instance suspensions are ordered should present to the commission all facts, circumstances, conditions or reasons which, in their opinion, tend to show that the increases should not be allowed.

The commodities affected by the decision include glucose, ice, canned goods and furniture; not over a dozen in all.

As a result of a conference between protestants and carriers, held prior to the hearing, the protest was withdrawn as to all of the increases excepting those upon blue vitriol, furniture and linseed oil to and from Kansas City.

Between Kansas City and St. Joseph the existing rate on furniture is 7 cents, with a graduated minimum according to the length of the car based upon 16,000 lbs. for a 36 ft. car. The tariff increases this rate to 9 cents; the present rate of 7 cents between Leavenworth and St. Joseph is increased to 8 cents.

The linseed oil rate of 9 cents between upper and lower Missouri river crossings is to be made 10 cents.

Observers at Chicago say that the advances involve less than \$100,000 to all roads. Railroads concerned do not regard this action as any particular concession, or as presaging any other concessions.

#### STATE COMMISSIONS.

The Oklahoma Corporation Commission has issued an order that interstate passengers riding through Oklahoma must be permitted to stop in order to purchase tickets at the nearest station to the state line, when leaving or entering, or be allowed to pay cash fare on the trains without the usual excess penalty, in order to give them the advantage of the two-cent-a-mile intrastate rates, instead of being required to pay the higher interstate rates.

The Railroad Commission of Wisconsin has adopted the code of rules governing the construction, maintenance and operation of interlocking plants, on steam and electric railways, which were formulated recently by the engineers of the commissions of four states—Wisconsin, Minnesota, Illinois, Indiana—and has ordered that they become effective December 1 next. Prior to their adoption of these rules the state engineers had held a number of conferences with prominent railroad signal engineers.

The Missouri Public Utilities Commission has been holding hearings on a complaint of the Kansas City Board of Trade, that the railways are transporting grain shipments destined for Kansas City, Mo., through Kansas City, Kan., in order to collect the higher interstate rates instead of the state rates. The railways contend that it is often necessary to move such shipments via their Kansas City, Kan., terminals and that, in other cases, much of the grain is reconsigned to the latter city, making the shipments interstate.

#### COURT NEWS.

The Supreme Court of the United States has sustained an order of the Indiana Railroad Commission, issued in 1906, fixing freight rates on the Vandalia Railroad.

The Federal Court in Colorado has imposed fines of \$1,000 each, for violation of that section of the interstate commerce law forbidding the giving of free passes, on the Denver & Rio Grande, the Colorado & Southern, the Victor American Fuel Company, Colorado Fuel and Iron Company, United States Portland Cement Company, Colorado Portland Cement Company and the Great Western Sugar Company. The indictments were found a year ago. All were for giving or receiving passes within the state of Colorado.

**CYLON'S RAILWAYS.**—The railways of Ceylon are owned by the government, and there were 577 miles of line in operation at the end of June, 1911. Certain lines from Ratnapara to Mannar are under construction, while the construction of the Chilaw line has been authorized.

## Railway Officers.

### Executive, Financial and Legal Officers.

M. T. Coogan has been appointed auditor of the Ashley, Drew & Northern, with headquarters at Crossett, Ark.

J. W. Newlean, whose election as vice-president and comptroller in charge of the financial accounting and supply departments of Wells Fargo & Company, with headquarters at Chicago, has



J. W. Newlean.

already been announced in these columns, was born on October 28, 1875, in Chicago. He was educated in the public schools of Omaha, Neb., and began railway work on December 1, 1891, in the freight claim department of the Chicago, Burlington & Quincy. He went to the Union Pacific in March, 1892, and filled various subordinate positions in different offices of the accounting department until July, 1901, when he was transferred to the service of the general auditor of the Union Pacific and the Southern Pacific, then known as the "Harriman System," and later was appointed chief clerk. In February, 1909, he became general auditor for the receivers of the Chicago Great Western, and in September of that year he was made auditor of the reorganized company. Mr. Newlean was appointed general auditor of the Illinois Central and the Yazoo & Mississippi Valley in January, 1911, which position he held until March, 1912, when he became comptroller of Wells Fargo & Company. He is now elected vice-president and comptroller, as above mentioned.

Frederick S. Holbrook, general traffic manager of Wells Fargo & Co. Express at New York, has been elected vice-president in charge of traffic. He was born on September 25,



F. S. Holbrook.

1864, and began railway work in 1881, as a clerk on the Ogdensburg & Champlain, now a part of the Rutland, at Norwood, N. Y. From 1886 to 1889, he was chief clerk in the general freight office at Ogdensburg, N. Y., and then for two years was agent of the same road, also the Central Vermont and the Canadian Atlantic at Rouses Point. In 1890 he was made cashier of the Ogdensburg Transit Company at Chicago, and in 1894 became cashier of the Central Vermont at Pier 36, East river, N. Y., becoming commercial agent of the same road in 1896 at New York. He went to the West Shore in February, 1900, as assistant general freight agent, and left that company in March of the following year to become first assistant general freight agent of the New York, New Haven & Hartford at Boston, Mass. From July, 1901, to September, 1908, he was general freight agent of the same road at New Haven, Conn. In September, 1908, he became chairman of the committee on Classification at.

Chicago, and from May, 1909, to January, 1912, was chairman of the Official Classification Committee at New York. He was appointed general traffic manager of Wells Fargo & Co. Express on January 1, 1912, and now becomes vice-president in charge of traffic of the same company, as above noted.

E. I. Grenfell, assistant general auditor of the Colorado & Southern, has been appointed auditor of the Fort Worth & Denver City and consulting auditor of the Wichita Valley, with headquarters at Fort Worth, Tex., succeeding S. M. Hudson, deceased.

George S. Hobbs, general manager of the Maine Central at Portland, Me., has been appointed second vice-president in charge of the traffic, treasury and accounting departments, with headquarters at Portland, and will perform such other duties as may be assigned to him by the president. He has been elected president also of the Sandy River & Rangeley Lakes, the Bridgton & Saco River, and the Bridgton Telegraph Company.

#### Operating Officers.

W. J. Feiser has been appointed trainmaster of the Lake Erie & Western at Lima, O., in place of C. E. Meyer, transferred.

J. D. Stack has resigned as division superintendent of the Oregon-Washington Railroad & Navigation Company at Portland, Ore.

James P. Fallon has been appointed trainmaster of the Cincinnati Terminal division of the Baltimore & Ohio Southwestern at Cincinnati, O.

William H. Carter has been appointed trainmaster of the Cleveland, Cincinnati, Chicago & St. Louis at Springfield, O., in place of O. C. Wyman.

M. J. Wise, superintendent of the Southern Railway in Mississippi, at Columbus, Miss., has been appointed assistant to the general manager of that road and the Mobile & Ohio, with headquarters at Mobile, Ala., and F. E. Patton succeeds Mr. Wise.

W. L. Wroe has been appointed assistant superintendent of the Texas & New Orleans and the Galveston division of the Galveston, Harrisburg & San Antonio, with office at Houston, Tex., to succeed C. Woodard, resigned.

W. B. Causey, superintendent of the Southern division of the Chicago Great Western, at Des Moines, Iowa, has been appointed superintendent of the northern division, with headquarters at St. Paul, Minn., succeeding C. E. Carson, resigned, and C. A. Shoemaker, assistant superintendent at St. Joseph, Mo., succeeds Mr. Causey.

Dana C. Douglass, assistant to president of the Maine Central at Portland, Me., has been appointed general manager in charge of the operating department, with headquarters at Portland, succeeding George S. Hobbs, promoted, and his former position has been abolished. He was born on February 2, 1877, at Leeds, Me., and began railway work in July, 1894, as a stenographer in the passenger department and to the general manager of the Maine Central. From November, 1897, to February, 1910, he was secretary to general manager and vice-president and general manager of the same company. In February, 1910, he was appointed assistant to vice-president and general manager, and in July, 1913, became assistant to the president of the same road, which position he held at the time of his recent appointment as general manager of the Maine Central, also of the Portland Terminal Company.

A. G. Wells has resumed his duties as general manager of the Atchison, Topeka & Santa Fe Coast Lines after a leave of absence for six months. I. L. Hibbard, who has been acting general manager, will take his former position as general superintendent at Los Angeles, relieving J. R. Hitchcock, who returns to his former office as superintendent of the Los Angeles division, with headquarters at Los Angeles. J. B. Galivan, who was acting superintendent of the Los Angeles division, has been appointed trainmaster of the First and Second districts and Redlands, and Highland branch loop, Los Angeles division, with office at San Bernardino, Cal., in place of E. E. McCarty, who has been transferred to Needles, Cal., as trainmaster of the First district, Arizona division, succeeding A. R. Wood, who has been appointed trainmaster of the First district Albuquerque division, at Gallup, N. M., to succeed William Thomas.

Harry E. Patterson, who has been appointed assistant superintendent of the Buffalo, Rochester & Pittsburgh, with headquarters at East Salamanca, N. Y., as has been announced in these columns, was born on January 14, 1870, at Dunkirk, N. Y., and was educated in the public schools. He served for a time as assistant to the agent and as telegrapher, and later as relief operator and agent on the Dunkirk, Allegheny Valley & Pittsburgh, and in 1887, went to the Merchants Despatch Transportation Company at East Rochester as car accountant. The following year he was made chief clerk of Wicks Refrigerator Company. He went to the Buffalo, Rochester & Pittsburgh as an operator on October 9, 1889, and has been in the continuous service of that road ever since. From June, 1891, to October of the following year he was agent, and then to December, 1896, was division clerk and copier. He was made train despatcher in December, 1896, remaining in that position until June, 1903, when he was promoted to chief train despatcher, becoming trainmaster on September 1, 1911, which position he held at the time of his recent appointment as assistant superintendent of the same road as above noted.

M. G. McInerney, whose appointment as superintendent of the Buffalo and Rochester divisions of the Buffalo, Rochester & Pittsburgh, with headquarters at Rochester, N. Y., has been announced in these columns, was born in 1868



M. G. McInerney.

at Meadville, Pa., and was educated in the public schools, and at a business university at Rochester. He began railway work in August, 1881, as train crew caller on the Western New York & Pennsylvania, now a part of the Pennsylvania Railroad, and from 1883 to 1887, was telegraph operator and yard clerk. He then went to the Buffalo, Rochester & Pittsburgh, as switchman and assistant yardmaster, and in December, 1888, became general yardmaster at Rochester, of the same road. In December, 1903, he was ap-

pointed trainmaster of the Buffalo and Rochester divisions at Salamanca, N. Y., and in April, 1911, he was made assistant superintendent of the same divisions, with office at Rochester, and now becomes superintendent, as above noted.

#### Traffic Officers.

G. F. Boyce has been appointed general agent of the Chicago Great Western, at Rochester, Minn., in charge of freight and passenger traffic.

Frank Armstrong has been appointed local freight agent of the Chicago, Burlington & Quincy at Chicago, in place of J. M. Powell, deceased.

W. L. Kendall has been appointed agent of the Erie Despatch, with headquarters at Cedar Rapids, Iowa, succeeding W. P. Kernan, resigned.

R. T. Hughes has been appointed traveling passenger agent of the Erie, with office at San Francisco, Cal., succeeding C. T. Slauson, promoted.

W. C. Wherritt has been appointed contracting agent of the Louisville & Nashville at New Orleans, La., succeeding O. H. Bartlette, deceased.

A. B. Lucky has been appointed city passenger agent of the Cincinnati, Hamilton & Dayton at Cincinnati, Ohio, succeeding Frank Eversman, resigned.

N. Hussey has been appointed soliciting freight agent of the Cincinnati, New Orleans & Texas Pacific and the Alabama Great Southern, with headquarters at Charlotte, N. C.

E. E. Livingston, general agent of the Chicago & North Western at Indianapolis, Ind., has been transferred to Des Moines, Ia., in a similar capacity, succeeding C. F. Miley, resigned.

Garland Tobin, southwestern passenger agent of the Missouri Pacific, the St. Louis, Iron Mountain & Southern, the Denver & Rio Grande, and the Western Pacific at San Antonio, Tex., has been appointed district passenger agent of these lines, with office at Birmingham, Ala.

C. T. Randall, contracting freight agent of the Minneapolis, St. Paul & Sault Ste. Marie at Cincinnati, O., has been appointed traveling freight agent, with headquarters at that point, in place of W. A. Boehm, who has been granted leave of absence owing to ill health. F. W. Mager succeeds Mr. Randall.

Alexander Hilton, general passenger agent of the St. Louis & San Francisco, has been appointed passenger traffic manager, with headquarters at St. Louis, Mo. He was born at Hamilton, Ont., and began railway work in 1878, as a clerk on the Great Western Railway of Canada, now a part of the Grand Trunk. From 1880, to December, 1884, he was a clerk in the passenger department of the Chicago & Alton, and then to 1889 was city passenger and ticket agent of the same road at Kansas City. In 1887 he acted as Pacific coast agent at San Francisco, Cal., and from 1889 to March 1, 1901, was general agent in the passenger department of the same road at Kansas City. On March 1, 1901, he was appointed assistant general passenger agent of the Kansas City, Fort Scott & Memphis; the following August he was made general passenger agent of its successor, the St. Louis & San Francisco, and now becomes passenger traffic manager of the same road. Since January 1, 1905, when the office of passenger traffic manager was abolished, he has assumed the duties of that position without change of title.



A. Hilton.

#### Engineering and Rolling Stock Officers.

F. M. Thomson has been appointed assistant engineer of the Houston & Texas Central at Ennis, Tex.

Mark Jefferson has been appointed assistant master mechanic of the Lehigh Valley, with office at Easton, Pa.

J. A. Rohrer has been appointed roadmaster of the Atchison, Topeka & Santa Fe Coast lines at Dalies, N. M., in place of H. D. Young.

Gilbert Dempster has been appointed master mechanic of the Southern Railway Company in Mississippi, with headquarters at Columbus, Miss.

C. H. Tillett has been appointed supervisor of signals, eastern lines, of the Grand Trunk, with headquarters at Montreal, Que., succeeding R. A. Becker, resigned.

Harry Whitham has been appointed division foreman of the Atchison, Topeka & Santa Fe Coast Lines, with headquarters at Gallup, N. Mex., succeeding George E. Johnson.

H. E. Passmore has resigned as master mechanic of the Toledo & Ohio Central to become vice-president of sales of the Eastern district for the Grip Nut Company, with headquarters for the present at Bucyrus, O.

Edward L. Adams has been appointed assistant signal engineer of the Lake Shore & Michigan Southern and the Dunkirk, Allegheny Valley & Pittsburgh, with headquarters at Cleveland, Ohio, succeeding Frederick B. Wiegand, promoted.

Fred W. Nelson, whose appointment as master mechanic of the Western division of the New York, New Haven & Hartford with headquarters at Waterbury, Conn., has been announced in these columns was born on April 25, 1876, at Ogdensburg, N. Y., and was educated in the high schools. He began railway work in December, 1900, as a fireman on the New York, New Haven & Hartford and has been in the continuous service of that road ever since. In March, 1903, he was made engineman, and from December, 1910, to May, 1913, he was road foreman of engines. He was promoted to general road foreman of engines on May 1, 1913, which position he held at the time of his recent appointment as master mechanic of the Western division of the same road, as above noted.

#### Special Officers.

Morris A. Zook, although at present engaged in the valuation of the Grand Trunk-Wabash joint line in Canada, he has not been appointed valuation engineer of the Grand Trunk. This corrects an item in our issue of September 5, page 434.

To facilitate the preparation of data and to consider problems involved in the valuation of the Minneapolis & St. Louis properties, in keeping with the act of congress, approved March 1, 1913, providing for a federal valuation of railroad properties, the following officers have been appointed a valuation committee, with authority to call upon all departments of the company for information needed in connection therewith: R. G. Kenly, chief engineer, chairman; L. G. Scott, auditor, and C. F. Foote, land and tax agent.

#### OBITUARY.

Stephen W. Noble, division freight agent of the Houston & Texas Central, at Fort Worth, Texas, died in that city on October 17, aged 60 years.

Luther Reese Zollinger, engineer maintenance of way of the Pennsylvania Railroad at Philadelphia, Pa., died on October 21, after a short illness, at his home in Merion, Pa. He was born in Harrisburg, Pa., on April 25, 1865, and graduated from high school and from Lehigh University, with the degree of civil engineer. He entered the service of the Pennsylvania Railroad on March 11, 1889, as a rodman in the office of the division engineer at Harrisburg. From February, 1891, to the following June, he was transitman at Altoona, and then to November, 1895, was assistant to division engineer, Philadelphia division, West Philadelphia. In November, 1895, he became assistant supervisor at Spruce Creek, and in October, 1898, was made supervisor at Norristown, later becoming supervisor at West Philadelphia. From May, 1902, to November, 1903, he was assistant to principal assistant engineer, Pennsylvania Railroad division at Altoona, and then, to April, 1905, was principal assistant engineer of the same division. On April 1, 1905, he was promoted to engineer of maintenance of way of the Pennsylvania Lines East, with office at Philadelphia, and since June 16, 1913, he had been in entire charge of the maintenance department. Mr. Zollinger's entire service had been with the Pennsylvania Railroad.

**TRAFFIC INTERRUPTED IN SPAIN.**—It is officially announced that at several points in Spain, notably on the east coast, floods have occurred, causing enormous damage. The Southern Railway of Spain is cut at several points. A train was derailed at Saragossa, while an express from Madrid was stopped at San Vicente. Traffic on the railway lines in the interior of Catalonia is also interrupted.

**INDO-CYLON CONNECTION.**—As at present arranged, the ceremonial opening of the Indo-Ceylon new route via Rameswaram will take place during the second week of January next, or a date to be fixed hereafter. It is possible that in the beginning it will be opened only for passenger traffic, goods traffic being carried later. All the viaducts have been completed with the exception of the Scherzer rolling lift bridge, which is in course of construction under the supervision of an American representative of the Scherzer Rolling Lift Bridge Company. It is expected that the bridge will be ready in about two months, and possibly trains will run over this bridge direct to Rameswaram until the opening of the through route to Ceylon.

## Equipment and Supplies.

### LOCOMOTIVE BUILDING.

THE PHILADELPHIA & READING has ordered 6 mikado locomotives from the Baldwin Locomotive Works.

THE PACIFIC GREAT EASTERN, 404 Welton building, Vancouver, B. C., is in the market for several locomotives.

THE GEORGIA, FLORIDA & ALABAMA has ordered one consolidation locomotive from the Baldwin Locomotive Works.

THE NEW ORLEANS GREAT NORTHERN has ordered one 10-wheel freight locomotive from the American Locomotive Company. The dimensions of the cylinders will be 20 in. x 26; the diameter of the driving wheels will be 61 in.; the total weight in working order will be 169,000 lbs., and the steam pressure will be 200 lbs.

### CAR BUILDING.

THE WABASH is asking prices on 500 steel gondola car bodies.

THE NORFOLK & WESTERN will build 1,000 hopper cars at the company's shops.

THE LEHIGH & NEW ENGLAND is making inquiries for 250 fifty-ton hopper cars.

THE NEW ENGLAND GAS & COKE COMPANY, Boston, Mass., is in the market for from 200 to 400 coal cars.

THE PACIFIC GREAT EASTERN, 404 Welton building, Vancouver, B. C., is in the market for about 200 freight cars.

THE BUFFALO, ROCHESTER & PITTSBURGH, mentioned in the *Railway Age Gazette* of October 17, as being in the market for 1,000 forty-ton box cars, 1,000 fifty-ton gondola cars and 1,000 fifty-ton hopper cars, has ordered 3,507 steel underframes and 1,000 fifty-ton hopper cars from the Cambria Steel Company.

### IRON AND STEEL.

THE CHICAGO, ROCK ISLAND & PACIFIC has ordered rolled 5,000 tons of titanium open hearth rails.

THE LEHIGH VALLEY has ordered about 2,000 tons of structural material for improvements at Buffalo, N. Y., from the Lackawanna Steel Company.

### SIGNALING.

The Cincinnati, New Orleans & Texas Pacific has placed in service two telephone circuits between Cincinnati and Danville, Ky. Train orders and messages will be handled exclusively by telephone over the 254 miles of this line between Cincinnati and Oakdale, Tenn., the telephone having been used between Danville and Oakdale for over two years.

The Western Maryland has contracted with the Union Switch & Signal Company for the installation of automatic signal protection at its single track tunnels at Knobley-Welton, Kessler, Stick Pile and Indigo tunnels, and at the Cranberry coaling station. This signaling will comprise a total of 23 blocks and 23 style "S" three-position signals will be used.

The Philadelphia & Reading is installing electro-pneumatic push-button apparatus for the operation of the switches in the eastbound classification yard at Rutherford, Pa. A total of 26 switches are included in this yard with one electro-pneumatic ground signal provided for governing movements onto the hump. Both the track circuits and switch movements in this work will be controlled by direct current delivered from duplicate sets of 14 cells of 320 ampere-hour storage batteries installed in the tower. The Union Switch & Signal Company has the contract for the complete erection of this work.

## Supply Trade News.

The Collins Metallic Packing Company, Philadelphia, Pa., has moved its general offices from The Bourse, to 56-58 North Second street.

F. R. Schueler has been appointed manager of the Chicago branch of Philip Carey Co., Cincinnati, Ohio, succeeding E. B. Cole, resigned.

The United States Light & Heating Company, New York, has moved its New England sales office from 84 State street, Boston, to 25 Irvington street. This is where the company's New England service station was already located.

On Wednesday, October 22, on the application of the First National Bank of Philadelphia, in which the company joined, the Standard Roller Bearing Company, Philadelphia, was placed in the hands of R. S. Woodward, Jr., president of the company, and S. Laurence Bodine as receivers.

The Conley Frog & Switch Company, Memphis, Tenn., has begun work on an addition to its plant 40 ft. x 100 ft., which will be used as an erecting shop. The building will be of steel construction, equipped with two trolley ways and pneumatic hoists, and is to be in operation by December 1. This company has also in the course of construction a plant at Port Arthur, Canada, to be known as the Canadian Conley Frog & Switch Company. The main building will be 80 ft. x 200 ft.; an office building, 40 ft. x 50 ft., and a storeroom 40 ft. x 50 ft. All buildings are to be of concrete construction and the plant is expected to be in operation by June 1, 1914.

H. E. Passmore has resigned as master mechanic of the Toledo & Ohio Central to become vice-president of sales in charge of the eastern district for the Grip Nut Company, Chicago.

He will have headquarters for the present at Bucyrus, O. Mr. Passmore was born at York, Pa., in November, 1869, and was educated at York Collegiate Institute and the Maryland Institute at Baltimore, Md. He served his machinist's apprenticeship with the Pennsylvania at Altoona, Pa., worked as a machinist for the Norfolk & Western, Baldwin Locomotive Works, Philadelphia & Reading and Western Maryland. In 1903 he entered the service of the Toledo & Ohio Central as machinist. He advanced through the ranks to the position of master mechanic which he has



H. E. Passmore.

filled with due credit to himself and satisfaction to his company, and which he leaves on November 1 to enter the supply field. Mr. Passmore has been an active member of the Master Mechanics' and of the Master Car Builders' Associations, is now a member of some of the more important committees, and has a host of friends who welcome him into his new field of endeavor.

Benjamin Tucker Lewis, western manager of the Railway Appliances Company, Chicago, whose death on October 11, was noted in last week's issue, was born in Madison county, Indiana, June 8, 1853. He began his business career as clerk and private secretary to the president of the Chicago & Iowa and Chicago, Pekin & Southwestern Railways in 1872; later becoming secretary and director, and also purchasing agent and general passenger and ticket agent for these companies, the Chicago, St. Louis & Western and the Chicago & St. Louis until 1887. From 1887 to 1890 he was director of purchases and tax and fuel agent of the Chicago, Santa Fe & California. From 1890 to

1900, he was assistant to the vice-president and general manager of the Santa Fe & Mexican Central, with residence at Topeka, Kan., to 1898, and at Mexico City 1898 to 1900. He became identified with the Railway Appliances Company in July, 1901.

The Westinghouse Electric & Manufacturing Company, Pittsburgh, Pa., has received among others the following recent orders: For use in connection with the electrification of the Norfolk & Western, three 9,000 kw., 25-cycle, 11,000 v., 1,500 r. p. m. single-phase, turbo alternators with two 150 kw. 250 v. turbo exciters and one motor generator exciter of the same rating, one 200 kva. O. I. S. C., 3-phase, 25-cycle, 11,000/440 v. transformer; three 1,500 kva. O. I. S. C., single-phase, 25-cycle, 33,000/11,000 v. auto transformers and six 2,500 kva., and four 3,000 kva. auto transformers of similar characteristics; one 10 per cent. reactance for the 11,000 v. feeder circuit and one type TA voltage regulator for the turbo-generators; and for the Oakland, Antioch & Eastern, one 750-kw., synchronous motor generator set consisting of two 650 v. D. C. generators connected in series, and 11,000 v., 3-phase, 60-cycle, 514 r. p. m. motor with direct connected exciter.

**Annual Report Pullman Company.**

Gross earnings of the Pullman Company for the fiscal year ending June 30, 1913, were \$42,860,891.37, as compared with \$40,219,748.03 in 1912, and were the largest in the history of the company. Operating expenses, repairs, taxes and insurance amounted to \$22,633,918.73, only slightly in excess of the 1912 figures, leaving an excess of revenue over expenses of \$1,541,601.50 as compared with \$828,998.28 in 1912. The reserve for further depreciation on cars in general was increased from \$2,000,000 to \$3,000,000 for the year. The income account follows:

REVENUE.	1913.	1912.
From Earnings of Cars.....	\$40,196,635	\$37,630,485
From Manufacturing, Rentals, Interest, etc.....	2,664,255	2,589,262
	\$42,860,891	\$40,219,748
EXPENSES.		
Operating expenses, repair of cars, taxes and insurance .....	\$22,633,918	\$22,608,177
Proportion of net earnings paid other interests in Sleeping Car Associations controlled and operated by this company.....	356,766	324,013
Depreciation on cars wrecked and destroyed or otherwise disposed of, and on cars transferred from Standard to Tourist, etc.....	965,107	465,462
Depreciation on cars in general.....	4,763,991	4,393,635
Reserve for further depreciation on cars in general.....	3,000,000	2,000,000
Dividends declared .....	9,599,506	9,599,460
	\$41,319,289	\$39,390,749
Excess of Revenue over Expenses, applicable to Surplus Account .....	\$1,541,601	\$828,998

The balance sheet shows an increase in net surplus from \$2,884,381 to \$4,425,983 and in the depreciation reserve from \$20,497,393 to \$28,210,450. The figures:

ASSETS.	
6,713 Cars and Equipments .....	\$112,440,422.62
*Amount invested in other Car Associations controlled and operated by this company.....	1,088,041.12
Pullman Building .....	1,068,759.04
Repair Shops .....	2,408,485.04
Other Real Estate .....	7,468.22
Operating Supplies, Linen, etc.....	4,619,258.60
Securities .....	\$9,163,909.83
Cash .....	5,461,968.38
Accounts Receivable .....	2,149,051.77
	16,774,929.98
Manufacturing Department, Plants and Investments.....	20,136,408.32
<b>Total Assets .....</b>	<b>\$158,543,772.94</b>

\*Total number of cars owned and controlled, 6,936.

LIABILITIES.	
Capital stock issued, 1,200,000 shares, par value \$100 each..	\$120,000,000.00
Accounts Payable .....	\$5,624,200.93
Reserves for depreciation .....	28,210,450.74
Other Reserve and adjustment accounts.....	283,138.21
	34,117,789.88
	<b>\$154,117,789.88</b>
<b>Net Surplus .....</b>	<b>\$4,425,983.06</b>

**TRADE PUBLICATIONS.**

**PLANERS.**—The Niles-Bement-Pond Company, New York, has published bulletin No. 24, describing its large engine lathes, milling machines and planers.

**CUTTING AND THREADING TOOLS.**—The Borden Company, Warren, Ohio, has published a catalog illustrating and briefly describing its cutting and threading tools. Prices and dimensions are included.

**TURRET MACHINERY.**—The Acme Machine Tool Company, Cincinnati, Ohio, has issued a new catalog describing its turret lathes and accessories, various types of screw machines, and turret lathe tool accessories.

**ACETYLENE SIGNALS.**—The Commercial Acetylene Railway, Light & Signal Company, New York, has published an illustrated booklet entitled, The Light That Never Fails, describing its system of lighting for railway signals.

**CONCRETE CULVERTS.**—The Northwestern Expanded Metal Company, Chicago, has issued a booklet illustrating and describing a large number of installations of concrete culverts reinforced with "Econo" expanded metal.

**CRANE MOTORS.**—Manning, Maxwell & Moore, Inc., New York, has published bulletin No. 109, describing type Z crane motors made by the Shaw Electric Crane Company. These motors are designed exclusively for crane service.

**DRILLS.**—The Colburn Machine Tool Company, Franklin, Pa., has published an illustrated folder entitled, Twentieth Century Drilling, in which are described the Colburn heavy duty drill presses. Several installations are shown.

**RIVETING HAMMERS.**—The Ingersoll-Rand Company, New York, has published form No. 8,011 on its Little David riveting hammers of suitable size for structural work, tank, steel, and any other similar work up to 1¼ in. diameter rivets.

**SECOND-HAND RAILWAY EQUIPMENT.**—The Walter A. Zelnicker Supply Company, St. Louis, Mo., has published bulletin No. 142, giving a list and a brief description of its second-hand locomotives, cars, rails, frogs, switches, crossings, bridges, turntables, dredges, excavators, etc. A copy of this bulletin can be secured by applying to the company.

**SPRING-PLUG COCK.**—The National Tube Company, Pittsburgh, Pa., has published an illustrated folder describing the National spring-plug cock, which was designed to overcome the disadvantages of the ordinary style, or through-plug cock. The spring-plug cock has an inverted plug with a spring at the bottom, which constantly presses the plug firmly against the seat.

**EARTH HANDLING MACHINERY.**—The Austin Manufacturing Company, Chicago, has issued an especially attractive illustrated catalog of the Austin line of earth handling, rock crushing, street cleaning and road building machinery, including graders, dump wagons, scrapers, plows, motor road rollers, gyratory crushers, elevators, screens, road machines, street sprinklers, oil sprayers, street sweepers and lawn mowers. The various types are fully described in connection with their various uses.

**RAILWAY PROSPERITY IN AUSTRALIA.**—Owing to the good seasons with which Australia has been favored during the past few years, rural settlement has largely increased and railway extension has gone on apace in all the States of the Commonwealth. The most ambitious schemes are those of the Queensland State government, which has passed a railways construction act providing for the building of two main trunk lines—one to link up the various ports along the eastern coast and the other to connect the inland termini of the railways which run down to these ports.

**NEW RAILWAYS FOR SOUTH AFRICA.**—The connecting link between Oudtshoorn and George was opened on August 6, 1913. This 45 mile branch reduces the distance by rail from Fort Elizabeth to Cape Town from 839 miles to 664 miles, and from Oudtshoorn to Cape Town from 910 to 387 miles. Formerly the journey by rail from Cape Town to Port Elizabeth, Oudtshoorn and the western coastal sections of Cape province beyond Mossel Bay was made via De Aar Junction, a station 500 miles almost due north of Cape Town. This connection is expected to make Mossel Bay a more important port. The new 27 mile Butterworth-Idutywa branch connects Butterworth, capital of the Transkei, with Idutywa, in the Pondoland, and Tombuland sections of the Transkei, and will be beneficial to both import and export trade.

## Railway Construction.

**ATCHISON, TOPEKA & SANTA FE.**—The report of this company for the year ended June 30, 1913, shows that work on the Dodge City & Cimarron Valley from Dodge City, Kan., southwesterly to Elkhart, about 120 miles, was completed, and the line was put in operation on July 1, 1913. The Minkler Southern was organized to construct new lines through a rich orchard country in the San Joaquin Valley, Cal. Of the projected lines about 40 miles between Wahtoke, Cutler and Exeter are now under construction. The lines in west Texas, on which construction was started in 1909, are completed with the exception of the extension of a Coleman-Lubbock line from Lubbock, Texas to Texico, N. M. This 89-mile extension is about three-quarters completed and will probably be opened for business about January 1, 1914. During the year the Verde Valley was completed from Cedar Glade to Clarkdale, Ariz., about 38 miles, and is now in operation. The work on the Northwestern Pacific, which is owned jointly by the A. T. & S. F. and the Southern Pacific, between Willetts, Cal., and Shively has been continued during the year; 24.95 miles have been completed, leaving 41.20 miles yet to be built. The construction of this line involves very heavy work through a mountainous country. A large amount of grading on the remaining section has already been done and the work will be pushed to completion. The mileage of second track in operation on June 30, 1913, was 898.32 miles as compared with 801.90 miles at the close of the preceding fiscal year, being an increase of 96.42 miles. Second track work is now in progress as follows: Missouri division, Floyd, Mo., to Sibley, 3.63 miles; Lines West of Albuquerque, Rito, N. Mex., to Laguna, 9.16 miles; Cactus, Ariz., to Flagstaff, 43.32 miles; Ash Fork to Pan, 22.55 miles, and Summit, Cal., to Keenbrook, 10.69 miles, a total of 89.35 miles. It is expected that all the second track work in progress will be completed by January 1, 1914, making a total at that time of 987.67 miles of second track in operation. Work on a new passenger station and extensive passenger facilities at Kansas City, Mo., to be used by all the roads entering Kansas City, is nearing completion.

**CALIFORNIA ROADS (Electric).**—We are told that a company is being organized in California to build an interurban line from Fresno, Cal., northeast to Clovis, about six miles. Mahoney Brothers, San Francisco, Cal., are back of the project.

**CANADIAN PACIFIC.**—The Board of Railway Commissioners of Canada has authorized the opening for traffic of the branch line on the Alberta division from Suffield westerly to Terrace, mileage 0 to 26.4, and of the second track between Chaplin, mileage 54, to Ernfold, mileage 66.5, on the Swift Current subdivision. Grading has been completed for some distance further west, and it is expected that the entire second track into Swift Current will be laid by the end of October.

**CHICAGO, BURLINGTON & QUINCY.**—An officer writes regarding the construction of a new line from Omaha, Neb., to Fremont, that some line will probably be built in the spring to shorten the distance over the existing Burlington line to Fremont. Two or three routes are being considered, but no decision as to the route over which the line will be built has yet been made.

**CHICAGO, ROCK ISLAND & PACIFIC.**—The Malvern & Camden was opened for regular passenger and freight traffic on October 12, from Malvern, Ark., via Willow and Sparkman to Camden. Daily motor car passenger service has been inaugurated between Butterfield and Camden and local freight service between Malvern and Camden. (November 1, p. 861.)

**COLORADO, KANSAS & OKLAHOMA.**—We are told that this company will let contracts in about 60 days to build an extension from Winona, Kan., north towards Denver, Colo., and that the work will be started next spring. The work involves handling about 10,000 cu. yds. to the mile. Maximum grades will be 0.5 per cent., and maximum curvature 3 deg.

**DENVER & SALT LAKE.**—The directors of the railway and the Denver tunnel commission have signed the contract, authorized by a city ordinance, providing for a loan by the city to aid in the construction of the proposed six-mile tunnel under James Peak. A city election will be held to authorize a bond issue for the amount. (September 5, p. 436.)

**DETROIT, LANSING & GRAND RAPIDS.**—See Michigan Roads (electric).

**DOLORES, PARADOX & GRAND JUNCTION.**—An officer writes that the company expects to let contracts next year to build from Dolores, Colo., northerly to timberland, about 15 miles. E. M. Biggs, president, Chamber of Commerce building, Denver.

**ESSEX TERMINAL RAILWAY.**—Surveys have been completed for an extension from Sandwich to the site of the new steel plant at Objibway, Ont., about three miles. The right of way has been secured, and the Board of Railway Commissioners of Canada has authorized the building of the extension at grade across several highways. It is expected that construction work will be started at once.

**GRAND TRUNK.**—Trains are now in operation between Cass City, Mich., on the Pontiac, Oxford & Northern, and Bad Axe, 19 miles.

**GREEN RIVER & UINTAH BASIN.**—We are told that a reconnaissance has been made for a line from Elgin, Utah, north via Ouray and Randlett, to Roosevelt, 140 miles, but the location survey has not yet been made, and it has not yet been definitely decided when construction work will be started. There are to be five steel bridges, each 450 ft. long on the line. The company expects to build under the name of the Green River & Uintah Basin, and to develop a traffic in coal, live stock, agricultural products, etc.

**HENRYETTA INTERURBAN.**—According to press reports financial arrangements have been made to build the line from Henryetta, Okla., east to the mines at Dewar, thence north to Coalton, about 10 miles. C. H. Kellogg, president, Oklahoma City. (September 19, p. 541.)

**HOUSTON & TEXAS CENTRAL.**—Trains are now in operation on the line between Giddings, Tex., and Bryan, 52 miles.

**LONDON, GRAND BEND & STRATFORD.**—Application is being made to the Ontario legislature for incorporation by this company to build from London, Ont., northwesterly through the townships of London, Lobo, East Williams, West Williams, McGillivray and Stephen, including the village of Parkhill, to Grand Bend, thence easterly to Exeter and Stratford, and then westerly to London, with branch lines. Gray & Gray, Toronto, Ont., are solicitors for the applicants. A. E. Beer and C. T. McAllister, represent the promoters at Parkhill, and engineering parties are reported to be going over the projected routes.

**MALVERN & CAMDEN.**—See Chicago, Rock Island & Pacific.

**MICHIGAN ROADS (Electric).**—According to press reports plans are being made for the construction of a new electric line between Detroit, Mich., and Grand Rapids, 150 miles. A new company has bought the right of way of the Detroit, Lansing & Grand Rapids, and financial arrangements are to be made so that work may begin early in the spring of 1914. Residents of Detroit and New York are said to be back of the project.

**MINNEAPOLIS, ST. PAUL & SAULT STE. MARIE.**—The report of this company for the year ended June 30, 1913, shows that during the year the company had under construction 85 miles of additional main track from Ambrose, N. D., west, which will be completed in time to move this season's crop. Construction of freight terminals in the city of Chicago now under way will be finished by January 1, 1914, and extensive additions to the shops at Shoreham, Minn., are being made.

**MONTREAL & SOUTHERN COUNTIES (Electric).**—A contract has been given to John Ross, of Ross & McComb, for work on this line, through the town of Granby, Que. The company recently opened for business a new section from Richelieu to Marieville, and work is now under way between Marieville and St. Cesaire. This section is nearing completion. (May 16, p. 1115.)

**NEW YORK SUBWAYS.**—The New York Public Service Commission, First district, will receive bids on November 12 for the construction of Section No. 5 of the Seventh avenue subway, in the borough of Manhattan, New York, and on November 18 for the construction of the extension of the Steinway tunnel in the borough of Queens, from the present terminus of the tunnel in Long Island City to the Queensboro bridge. The contract for the extension of the Steinway tunnel will be the last construction con-



## Railway Financial News.

tract to be made under the dual system for the borough of Queens, as all other parts of the new rapid transit system in that borough are now under contract. Steps will be taken for the construction of the extension of the Corona line from Sycamore avenue, Corona, to Main street, Flushing. The commission has authorized the immediate construction of this extension, and has asked the Board of Estimate and Apportionment whether it can find the money to pay for it as the first extension of the dual system. (October 17, p. 715.)

**NEZPERCE & IDAHO.**—This company, operating a line from Nezperce, Idaho, west to Vollmer, 13.8 miles, has finished grading, it is said, on a section of the extension building from Vollmer northwest via Craig Mountain, Waha and Tammany, to Lewiston, 55 miles, and track laying will soon be started. Ground has been bought for a terminal on the Snake river water front in Lewiston. (November 29, p. 1063.)

**PACIFIC GREAT EASTERN.**—An officer is quoted as saying that the company expects to have the line as far as Dubdarane ready for operation by January 1, 1914. This is part of the section from North Vancouver, B. C., to Newport, on Howe Sound. The plans call for building from Vancouver, B. C., to Fort George, about 350 miles. (September 19, p. 542.)

**PALACIOS, SAN ANTONIO & PECOS VALLEY.**—An officer writes that financial arrangements have been made to build from Palacios, Tex., on the Gulf coast, northwest to Yoakum. It is understood that residents of Yoakum will subscribe \$70,000 in aid of the project, and that contracts will be let soon. The company was organized some time ago to build from Palacios to Yoakum, and it is the intention to extend the line eventually to San Antonio, thence to Pecos, with a branch to Aransas Pass. (December 6, p. 1117.)

**PORTLAND, EUGENE & EASTERN.**—This road has been extended from Monroe, Oregon, south to Eugene, 24 miles. A new line has been opened for business from Canby, Oregon, to Molalla, 11 miles.

**PORTLAND & OREGON CITY (Electric).**—An officer of this company, which was incorporated in Oregon with \$200,000 capital to build a 14-mile line from Portland, Ore., south to Oregon City, writes that grading work is now being carried out by the company's forces. Bids are to be asked for about November 1, for the track laying, bridges, etc. There will be one steel bridge 180 ft. long. Steven Carver, president, Portland. (July 25, p. 169.)

**TORONTO, HAMILTON & BUFFALO.**—Plans have been submitted to the Hamilton, Ont., city council for the betterment of the railway entrances into the city, in connection with the city's application to the Board of Railway Commissioners of Canada for an order directing the T., H. & B. to abandon its present line on Hunter street. It is stated that the estimated cost of construction along the new route would be over \$1,000,000.

### RAILWAY STRUCTURES.

**CHICAGO, ILL.**—The Chicago & Western Indiana has prepared plans for a roundhouse, locomotive shop, machine shop, storehouse, turntable and ash pits to be built near its yards now under construction at Clearing, Ill.

**DES MOINES, IOWA.**—The Chicago, Rock Island & Pacific has announced that two new freight houses, each 600 ft. long, will be built next year.

**KANSAS CITY, MO.**—See Atchison, Topeka & Santa Fe.

**MACON, GA.**—An officer of the Central of Georgia writes regarding the report that a new union station is to be built in Macon, that no plans have been prepared or anything done further than to consider a site for the proposed station.

**PITTSBURGH, PA.**—An officer of the Pennsylvania Railroad writes that a contract has been given to John F. Casey, Pittsburgh, for the foundation work on the brick and terra cotta freight and office building to be built at Federal and North Canal streets in Pittsburgh. The building will be of fireproof construction and will have three stories, 40 ft. x 110 ft., with front building of two stories, 41 ft. x 894 ft. (July 18, page 132.)

**BANGOR & AROOSTOOK.**—At the annual meeting on October 21 Charles A. Milliken, of Augusta, Me., was elected a director, succeeding Arthur Holland, resigned.

**DETROIT, TOLEDO & IRONTON.**—The receiver has written to the attorney general of Ohio saying that the bondholders have agreed to bid in the road when it is sold under foreclosure January 20, 1914.

**ERIE.**—White, Weld & Co., New York, are offering \$2,350,000 Erie equipment trust 5 per cent. certificates, series U, of July 2, 1913, due serially 1914-1923, at prices yielding about 5.30 per cent. interest on the investment. The certificates are secured by 1,500 fifty-ton steel frame box cars, 500 fifty-ton steel hopper cars and 500 fifty-ton composite gondola cars. Of the total cost of the equipment the railroad company is to pay 16.9 per cent. in cash.

**GREENVILLE & KNOXVILLE.**—This road, which runs from Greenville, S. C., to River Falls, 23 miles, was on October 16 placed in the hands of W. H. Patterson, president, as receiver. The receivership proceedings were begun on the application of general creditors of the company.

**ILLINOIS CENTRAL.**—W. A. Harriman has been elected a director to fill the unexpired term of A. J. Hackstaff, deceased.

**NEW ORLEANS, TEXAS & MEXICO.**—The United States district court at Atlanta, Ga., has authorized the receiver of the N. O. T. & M. to borrow \$1,500,000 through the issue of receiver's certificates or otherwise, for use in the year ending September 14, 1914.

See also St. Louis & San Francisco.

**NEW YORK, NEW HAVEN & HARTFORD.**—At the annual stockholders' meeting, which was held on Wednesday, October 22, the by-laws were changed providing for a chairman of the board, and Howard Elliott was elected chairman and James H. Hustis was made president. James H. Hustis, James L. Richards and G. L. Stone were elected directors.

The sale of the \$67,500,000 convertible bonds was approved, and in one of his statements to the stockholders Mr. Elliott said: "If it should be necessary to go on a 4 per cent. basis, as many seem to fear, I trust that we can maintain at least that 4 per cent. and I hope to do better than that in a few years."

**ORANGE & NORTHEASTERN.**—E. Kennedy, president, is quoted as saying that arrangements have been made with the Commonwealth Trust Co., Houston, Tex., for the sale from time to time of \$1,000,000 first mortgage 5 per cent. bonds.

**ST. LOUIS & SAN FRANCISCO.**—The receivers have applied to the United States court at St. Paul for permission to issue \$10,000,000 receivers' certificates, of which it is proposed to sell \$5,000,000 certificates immediately.

See also New Orleans, Texas & Mexico.

**NEW CENTRAL RAILWAY STATION AT TOKYO.**—The most elaborate railway station in the Far East, the new Central Railway Station at Tokyo, Japan, will be completed next year at a cost of approximately \$1,400,000. The main building is 1,083 ft. by 132 ft., and the station is being constructed on a centrally located 50-acre tract of land, which will be decorated with Japanese gardens, fountains, etc. Aside from 1,300 tons of structural steel, being less than half of the amount utilized in the framework, and a quantity of tile, all the materials used in the construction of the new station are products of Japan, and include 7,500,000 bricks, 8,800 cu. yds. of concrete, 60,000 cu. ft. of granite, 26,000 barrels of cement, 150,000 sq. ft. of copper sheeting—which is used on the domes and in the roofing construction—and 200,000 cu. ft. of lumber. The building will be provided with the usual dining rooms, waiting rooms, etc., and provision may be made later for hotel accommodations. It is the intention of the Japanese authorities to have this station completed some time in advance of the coronation of the emperor in October, 1914. It is, of course, customary to give preference to Japanese-made products, price and quality being equal. In this instance the result is clearly a monument to the advance in the use of homemade goods in Japan.

# Railway Age Gazette

PUBLISHED EVERY FRIDAY AND DAILY EIGHT TIMES IN JUNE, BY THE SIMMONS-BOARDMAN PUBLISHING COMPANY, WOOLWORTH BUILDING, NEW YORK.

CHICAGO: Transportation Bldg. CLEVELAND: Citizens' Bldg.  
LONDON: Queen Anne's Chambers, Westminster.

E. A. SIMMONS, *President.*

L. B. SHERMAN, *Vice-President.* HENRY LEE, *Sec'y & Treas.*  
The address of the company is the address of the officers.

### EDITORS.

SAMUEL O. DUNN, *Editor.*

ROY V. WRIGHT, <i>Managing Editor.</i>	H. H. SIMMONS	E. S. FAUST
W. E. HOOPER	H. F. LANE	F. W. KRAEGER
B. B. ADAMS	E. A. AVERILL	A. D. CLOUD
E. T. HOWSON	R. E. THAYER	GEORGE L. FOWLER
	A. C. LOUDON	

Subscriptions, including 52 regular weekly issues and special daily editions published from time to time in New York, or in places other than New York, payable in advance and postage free:

United States and Mexico.....	\$5.00
Canada .....	6.00
Foreign Countries (excepting daily editions).....	8.00
Single Copies .....	15 cents each

Engineering and Maintenance of Way Edition and four Maintenance of Way Convention Daily issues, North America, \$1.00; foreign, \$2.00.

Entered at the Post Office at New York, N. Y., as mail matter of the second class.

WE GUARANTEE, that of this issue 8,150 copies were printed; that of these 8,150 copies, 6,559 were mailed to regular paid subscribers and 848 were provided for counter and news companies' sales; that the total copies printed this year to date were 880,008—an average of 8,636 copies a week.

VOLUME 55. OCTOBER 31, 1913. NUMBER 18.

## CONTENTS

### EDITORIAL:

Editorial Notes .....	807
Appointments to the Interstate Commerce Commission.....	809
Increasing the Loading of Cars.....	810
Atchison, Topeka & Santa Fe.....	811, 846
Minneapolis, St. Paul & Sault Ste. Marie.....	813, 849
New Books .....	813

### MISCELLANEOUS:

*Wreck Caused by a Broken Tire.....	814
Movement for the Simplification of Tariffs.....	816
*New O.-W. R. & N. Terminal at Spokane.....	817
Powdered Coal as Fuel; by W. S. Quigley.....	819
Pure Drinking Water on the Southern Pacific.....	820
Conditions in the Investment World; by James J. Hill.....	821
Employees Oppose Chicago Electrification.....	823
*New Mississippi River Bridge at Memphis.....	824
Demands of the Western Enginemen.....	825
*A Division Office Building Designed for the Hine System of Organization .....	827
*Characteristics and Operating Features of the Gas Electric Car; by L. C. Joseph, Jr.....	828
The Economy of Capacity Loading from the Shipper's Point of View; by Gordon Wilson .....	830
Railway Electrical Engineers' Association.....	831
Foreign Railway Notes .....	816, 820, 825, 826

GENERAL NEWS SECTION..... 834

\*Illustrated.

CHAIRMAN CLARK summarized in a few sentences the most important phase of the railway situation when he said in his address before the National Association of Railway Commissioners on Tuesday: "An ideal transportation situation can be attained only by large additions to the facilities and great improvements in methods. The added facilities can be secured only through expenditures from surplus earnings or from expansion of credit. In either way the total cost to purchasers of transportation would be increased." It is difficult to comprehend how anyone who studies the statistics of earnings, of expenses, and of accidents of our railways, and who travels over them enough to be familiar with the physical condition of most of them can question the justice of Mr. Clark's summing up of the situation. Better

facilities are needed to make the service of our railways as adequate as it should be, as good as it should be, and as safe as it should be. If earnings were increasing faster in proportion than the demands upon earnings we could rest satisfied that in due time the physical properties and the service rendered would be improved as much as the public welfare requires, but the demands on earnings are increasing faster in proportion than are the earnings. In these circumstances the ability of the railways to make necessary additions to, and improvements in their facilities is declining instead of increasing. It follows that if the service is to be improved its cost to those who buy it must, as Chairman Clark says, be increased. The question arises then as to whether it is better to continue to have poor service and lower rates. That question should not be hard to answer. Since the public needs better service and insists on having it, since it bitterly criticises the managements of the railways when the car supply is inadequate, or when railway accidents occur owing to defective track or equipment, the public should be willing to pay the price that it must pay in order to enable the railways to give the kind of service that it demands.

THE payment of tips is now so common in large cities that any one who attempts to stem the tide is to be credited with unusual grit; and the action taken at Portland, Oregon, asking passengers not to offer tips, which is noticed in another column is, therefore, an experiment of which every railroad officer will be interested to know the result. The things that can be said for and against tipping are so trite that we shall not weary the reader by repeating them; but in view of the apparent state of public opinion, and railroad officers' opinion, on the Pacific coast, the reader will be interested in the remark recently made by an officer of a large Eastern passenger station, that the porters in his station, when they carry a passenger's hand bag, are more likely to receive twenty-five cents than ten. The size of a tip is, indeed, quite commonly an important consideration. If it were possible to change our customs so that every passenger could, without embarrassment, pay, for carrying his baggage, a sum of money somewhere near what the service is really worth to him—as is more nearly the case in Europe—our whole problem would be very much altered.

"GET Rich Quick Wallingford" has nothing on that notorious exponent of efficiency who was designated in the September *Review of Reviews* as the "high priest of efficiency," whatever that may be, and who was quoted by Mr. Brandeis in the rate hearing a couple of years ago as authority for the statement that the railways could save a million dollars a day. Thousands of dollars have been spent in the popular magazines during the past few weeks advertising an Institute of Efficiency, which claims that its "course of 24 lessons [by mail] will save you years of preparation. It will give you the results of 40 years of experience. It is a short cut to business success." Some of these same magazines pride themselves on protecting their readers from unscrupulous advertisers. In bold lines above this statement in the advertisement in one of the magazines appear the words "\$2,000 a month," which imply that the student who successfully completes the course will be in a position to command a big salary. A delightful picture to draw, but hardly fair for the poor chap who is not sufficiently well posted to realize its extravagance and who is of such an order of intelligence as to allow himself to be entrapped. In commenting on this feature the *Star-Telegram* of Fort Worth, Texas, says:

Formerly men served an apprenticeship and worked half a lifetime to reach commanding positions and good salaries.

Now the ambitious young man simply cuts a coupon out of the corner of an advertising page and writes for full instructions—paying a small sum of course as an evidence of good faith—and proceeds to take the business and industrial structure by the scruff and shake it into respectability and good form.

The head of the institution who "will personally supervise the whole course of instruction," is described as the man who first

made efficiency famous. "It was he who showed the railways how they could save a million dollars a day." Did he? Does anyone seriously think he could?

OUR contemporaries, the *Indianapolis News* and the *Omaha Bee*, have been discussing whether the decision of the Supreme Court of the United States in the Nebraska rate case has been overruled. It was in this case that the Supreme Court first laid down the principle that the true basis for the calculation of the reasonableness of railway rates was the fair value of the railway's property. The *Omaha Bee*, referring to the decision, says that it "indicated a method of computation decidedly favorable to the railroads," and both that paper and the *Indianapolis News* evidently hope that the precedent established in that case has been overruled. The view expressed by the *Omaha Bee*, namely, that the method of computation indicated by the Supreme Court in this case was decidedly favorable to the railroads, is one that is widely held. The truth is, however—and this is a fact almost entirely overlooked or ignored nowadays—that the method of computation referred to, when adopted by the court, was regarded as unfavorable to the railroads. In the Nebraska rate case the railways contended that the valuation should be based on the actual cost of their properties. Because of a decline in wages, prices and values all along the line following the panic of 1893, it was recognized that at that time the cost of reproducing the railways concerned would be less than their original cost. "In the cases before us, however," said the Circuit Court, "there is abundant testimony that the cost of reproducing these roads is less than the amount of the stock and bond account or the cost of construction, and that the present value of the property is not accurately represented by either the stocks and bonds or the original construction account." The Circuit Court held, however, that the investors in the railways had assumed the risks of investment, and that, therefore, if the present value of the properties was less than their original cost the investors must suffer. And the Supreme Court upheld this decision. Conditions changed subsequently. The wages of labor, the prices of materials and the value of railway land increased, and, in consequence, the time came when the cost of reproduction exceeded the cost of original construction. It is this change in condition, which has converted the method of computation adopted by the court from one which was unfavorable to the railways to one which is favorable to them, and those who got this method of computation adopted are being hoist by their own petard. And now they begin to complain about it. But if the method was fair when it was unfavorable to the railways, why it is not fair when it has become favorable to them? Or is the public's attitude in regulating the railways to be one of "heads I win; tails you lose."

ON Monday of this week the Interstate Commerce Commission had a hearing on the new tentative form of annual report which it proposes to require from steam roads. The most radical change in the form of this report is the provision for showing separately operating expenses incurred in freight and passenger service. The commission has been working with the sub-committee of the American Railway Accounting Association for more than a year on changes in the form of annual report to the commission, and Commissioner Meyer, who is in charge of statistics has shown that it is his conviction that an attempt must be made to assign freight and passenger expenses. In the tentative report, which was considered on Monday, provision is made for showing separately expenses caused "solely by revenue freight service"; expenses caused "solely by revenue passenger service," and expenses caused by joint, common and miscellaneous service. It is left optional with the companies as to whether or not the common expense shall be allocated on some formula which they are left to work out. The point Commissioner Meyer makes is this: If the cost of service is one of the determining factors in rate making, even if it is only a minimum below which the commission may not without violating the Fourteenth Amend-

ment reduce rates, it is the duty of the commission to try to get at that cost. In every case that comes before a court in which the commission's rates are attacked by a railroad company on the ground of confiscation, the railroads submit figures to show the cost of service. It was plainly apparent at the hearing that the commission believed that figures compiled to be submitted at a particular rate hearing are not based necessarily on sound accounting theory, but on a desire to win the particular case in hand, and that the commission has a right to ask for figures which are compiled on general principles and not in accordance with the expediency or necessities of a particular case. Of course, it is not difficult for railroad accounting officers to demonstrate the impossibility of accurately dividing all expenses as between freight and passenger service. Mr. Seger of the Union Pacific went so far as to claim that not a single expense, which a road doing both a passenger and a freight business incurs, is solely for revenue freight service or solely for revenue passenger service. He may be right theoretically, but the common sense of the commission is not apparently going to permit a theoretical hair-splitting objection, or even a great number of such objections to prevent them from making a beginning in the separation of expenses as between the two classes of service. One cannot blame the railroad companies for trying to avoid giving state commissions and irresponsible state legislatures ammunition with which to attack rates. On the other hand, it is an ostrich-like performance for the accounting officers to argue to the commission that no division of expenses can be made which will accurately show the cost of even freight service as a whole as distinguished from passenger service as a whole, while at the same time their own legal departments are fighting a rate reduction by the introduction of testimony to show a given rate on a given commodity is confiscatory. There may be some valid reasons why the assignable expenses should not be assigned in the annual reports to the commission, but these objections were not brought out at the hearing on Monday. Furthermore, if the commission really knows what it wants, it is going to get it, and a constructive criticism which will help the commission in getting figures which it wants will go much further toward preventing unnecessary expense to the railroad companies than will any amount of arguing about the theoretical impossibility of obtaining this information in a statistically pure and perfect form. It may be true that the original mistake was made by the railroad lawyers in laying so much stress on cost of service as a test of reasonableness but that is a mistake that cannot now very well be remedied.

THREE of the railroad brotherhoods at least were represented at the hearing on Monday, and they presented a strong plea that the form of annual report of the commission be changed so as to show the actual compensation received per month by each class of employees. Mr. Carter, in his effective, if somewhat bombastic, style, pointed out how misleading it was to lump firemen and hostlers together and to strike an average of their average wage. The representative of the Order of Railroad Clerks objected quite strongly to the lumping together of clerks and attendants. The points taken by the labor men were well made. In every wage controversy which has gone to arbitration the question of what compensation a specific class of employees are receiving is one of the disputed points and it should not be. Mr. Carter and the Bureau of Labor appeared to be anxious that the statistics relating to the wages paid railroad employees should be compiled by the Bureau of Labor and while undoubtedly the advice and assistance of the Bureau of Labor in formulating a system on which the roads are to report their wage expenses, will be of help to the commission, this matter lies clearly within the jurisdiction of the Interstate Commerce Commission. With the authority to regulate all the other accounts of the railroads and their rates, should go the responsibility of compiling the figures showing the wages paid by railroads. The English classification of expenses, crude as it is in some respects, separates every item as between wages and material. There is apparently no opposition on the part of the railroad officers to the sugges-

tions of labor people. The roads have nothing to lose and everything to gain by showing clearly what they are paying each class of employees. If, as a good many railroad men think, they are paying some classes too high, and others not high enough, it is a condition which public opinion if rightly informed will help them to correct.

#### APPOINTMENTS TO THE INTERSTATE COMMERCE COMMISSION.

**C**OMMISSIONER PROUTY is to retire from the Interstate Commerce Commission to take direct charge of the valuation of common carriers which Congress has required the commission to make. The term of Commissioner Clements will expire on January 1. These developments will give President Wilson an opportunity to appoint two members of the commission. It is to be hoped that he will take advantage of it to put strong and fit men on that body, thereby refraining both from impairing its efficiency and from setting bad precedents for future appointments.

Those who understand the true functions of the commission, and appreciate their great importance and the difficulty of properly performing them, easily agree on the principal qualifications which an appointee to the commission should possess and the principal disqualifications which he should not possess. At a time like this, however, it is desirable that these qualifications and disqualifications shall be iterated and reiterated so that they may constantly be borne in mind.

One of the most essential qualifications is a judicial mind. No man who has not such a mind can approach the problems of the commission impartially; and no man who cannot approach those problems impartially is fit to be on the commission. Since a judicial mind, together with the impartial attitude which only a judicial mind can have, is one of the most fundamental qualifications of a member of the commission, it follows that the burden of proof rests very heavily, indeed, on any who may advocate the appointment to it of any man who is or has been an active politician. It is very unusual for the quality of being judicial and the qualities of a politician to be united in the same person. A politician is bound to be a partisan, and a partisan can hardly be judicial. Furthermore, the railway question has been in politics in this country continually for at least ten years. As it has been in politics it has been necessary for the men who have been active politicians to be active partisans either for or against the railroads. Therefore, an active politician under present conditions has the double disqualification that he probably has not a judicial mind and that he probably has been and is a partisan on the railway question.

The politicians are already stirring to get one or more of their number appointed to the commission. Mr. Henshaw, who was formerly an agitator against the railways in Oklahoma, and who was elected a member of the Oklahoma Corporation Commission, is understood to be a candidate. So is Governor Glenn of North Carolina. It is inconceivable that President Wilson, appreciating, as he must, the need for men of a judicial mind on the commission, can seriously consider appointing Governor Glenn, Mr. Henshaw, or men of their type.

Another qualification which members of the commission ought to have when they are appointed is either a profound and comprehensive knowledge of railway and kindred problems acquired by study and investigation, or a practical working knowledge of railway problems and practices gained by experience. Seldom have the men elected or appointed to state commissions and the Interstate Commerce Commission possessed the qualification of either special knowledge or special experience. Many after appointment to state commissions and the Interstate Commission have become able and satisfactory regulating officials; but they have had to do years of work before they became so. As Chairman Clark has said in a recent letter, "It makes no difference how able a man may be it takes considerable time for

him to fully comprehend the complications involved in efforts at rate regulation and the removal of unjust discriminations." The commission is now dealing not only with railway rates, but with railway operation; and it seems probable that it will deal with railway operation more in the future than it has in the past. Therefore, with every year that passes the folly involved in appointing to it men who have no special knowledge of, or experience in dealing with, railway problems grows greater.

A third, and the most important, qualification of a member of the Interstate Commerce Commission is that he shall be a man of sterling character. By this is not meant merely one who is law-abiding and moral. All members of the Interstate Commerce Commission are and have been that so far as we know. What is meant is that he shall be a man so big in intellect and personality that he will command the confidence and respect of shippers, of railway officers, and of the public. The nature of the work of the commission is such that the effect that will be produced by one of its opinions, or orders, or reports depends largely on the character of the man who is known to have been the author of it. If the commission is to serve its purpose with the maximum effectiveness and the maximum benefit to the public it must be composed of men who will not arouse the suspicion that they are biased, narrow, unfair, or more disposed to split the ears of the groundlings by sensational utterances or acts than to so regulate the railways of the country as to best promote the rightful interests of both the railways and the public.

The salary paid to members of the Interstate Commerce Commission is relatively small. Their duties are onerous. Nevertheless, if it be made known that membership on the commission is to be a position of honor and trust, that the commission is to be left as free from political influence in the performance of its duties as is the Supreme Court of the United States, and that a man who has once been appointed to it and has performed his duties faithfully and well may count on reappointment for an indefinite period, there will never be any difficulty in getting and keeping the right kind of men on the commission.

If the foregoing considerations be well-founded it follows that Commissioner Clements should be appointed his own successor. Mr. Clements has done and said some things which have been open to criticism. But the integrity of his character is unquestionable; he has had years of experience; he has much natural ability; and, therefore, he is better fitted for membership on the commission than almost anybody who might be appointed to supersede him. As to a successor to Commissioner Prouty, the President will have no difficulty in finding a suitable man once he has got clearly in mind the true qualifications of such a man. He can find men possessing the needful qualifications in the economists in our universities, from which came President Hadley to be chairman of the Railroad Securities Commission, and B. H. Meyer to sit on the Railroad Commission of Wisconsin and on the Interstate Commission itself. He can find them among the members of some of the appointive state railway commissions; but he will have very great difficulty in finding any of them among the members of the elective state railway commissions. He can find them among the traffic managers of the large industrial concerns of the country. He can find them among the traffic and operating officers of the railways. It may be thought that a traffic manager of a large industrial concern or a traffic or operating officer of a railway would be biased; but neither of them would be anywhere near as likely to be a narrow partisan as would some active politician, and both would be much more likely to have the special knowledge and experience which an appointee to the commission should have.

Let us hope that President Wilson in making the appointments will be guided by good counsel and wisdom; for the kind of appointments he makes to the commission may affect the material welfare of the country more than any other appointments that he may make while he is President.

### INCREASING THE LOADING OF CARS.

ONE of the very best ways to increase the efficiency of railway operation is to increase the loading of cars. In no other way can the amount of traffic handled be increased with such small additions to fixed charges and operating expenses. It is well known that the capacity of freight cars has been augmented much more within recent years than the loads hauled. In consequence, the proportion of car capacity provided but not utilized has steadily increased. This involves economic waste to the railway, to the shipper and to the public. The smaller the number of tons hauled per car the greater is the cost of hauling each ton. When the cost of handling freight is made unnecessarily high, either the railway earns less net than it might, or the shipper is charged higher rates than would otherwise be necessary, or both of these results follow. If the average carload were increased the resulting benefits might be divided between the railway and the shipper, the one enjoying somewhat larger net earnings than he otherwise could, and the other enjoying somewhat lower rates than he otherwise could. Since heavier loading could be made to work advantageously to both the railway and shipper, it is an end toward the attainment of which it is obvious that they might beneficially co-operate.

It is gratifying and significant that it is a shipper who recently has called attention most forcibly to the desirability of heavier loading of cars. J. F. Townsend, traffic manager of the National Tube Company, has given publicity to figures regarding the results of a campaign for heavier loading of cars which has been carried on by the constituent companies of the United States Steel Corporation. Mr. Townsend says:

A comparative statement of the average carload of outbound traffic for the years 1911 and 1912 for the American Bridge Company, American Sheet & Tin Plate Company, American Steel & Wire Company, Carnegie Steel Company, H. C. Frick Coke Company, Illinois Steel Company, National Tube Company, Pittsburgh Steamship Company, Tennessee Coal, Iron & Railroad Company, and Universal Portland Cement Company, produces the following result: During the year 1911 the average carload was 34.6 tons, and for the year 1912 the average carload was 36.2, or an increase of 1.6 tons per carload. This increase of 3,200 lbs. to the average carload on outbound shipments means there were 76,105 fewer cars used to handle an equal tonnage as compared with the average carload of the year 1911, based on the outbound traffic of the above ten companies.

Both the shippers and the railroads have been benefited to almost an immeasurable extent in the switching and weighing avoided, i. e., the great saving in operating expenses; switching service on 76,105 cars or 152,210 terminal movements, and the expense of handling this additional number of both empties and loads through the various classification or interchange yards of the railroads from point of shipment to destination. Figure this in any manner that you may, it will prove conclusively the money value of conserving the freight car equipment, not only when there is a severe car famine, but at all times. To illustrate: One company saved 122 cars by loading only 100 lbs. heavier per car during the year 1912. The record of another company emphasizes the importance of heavier loading perhaps more than any other example, for even with only 400 lbs. per car increase on its traffic means that 15,836 fewer cars were required to move the same tonnage.

Continuing, Mr. Townsend calls attention to what the shippers of the Pittsburgh district alone could do to add to the car supply. He says that an increase in the average carload originating in the Pittsburgh district in 1912 equivalent to that secured by the United States Steel Corporation, namely, from 34 to 36 tons, would have resulted in the tonnage originating in this district being carried in 409,520 less cars. Assuming an average haul of 100 miles, he computes that the saving in car mileage would have been 40,952,400 car miles.

Another article on the same general subject was published in the *Traffic World* for October 18, and signed by "Co-operation." We surmise from its tone and substance that it also was written by Mr. Townsend. In it the writer presents forcibly the advantages in the way of greater economy and more adequate car supply that might be gained by both the railway and the shipper from better loading. We publish elsewhere in this issue an article on this subject by Gordon Wilson.

It would be easy to increase the average loading if the rail-

ways could raise their minimum carload weights. They have made many such raises within recent years, but every time there is an attempt to make a substantial advance serious difficulties are encountered. While shippers generally would benefit, at least through the reduction or abolition of car shortages which would result, there are many individual small shippers who are injured by advances in minimum weights. Being unable to load the minimums required they find it necessary to pay for an entire car when they cannot use it all, or to pay the less than carload rates. This is a very serious matter, for it is not to the interest of the railway or the public to have the small shipper placed at any disadvantage as compared with the large shipper if any reasonable means can be adopted to avoid it.

"Co-operation" suggests as an alternative for flat advances in carload minimums the adoption of a system of graduated carload minimums. In other words, he would apply one rate per 100 lbs. on less than carloads, a lower rate per 100 lbs. for a load of 20,000 lbs., a still lower rate per 100 lbs. for 60,000 lbs., and still lower rates for 80,000 lbs., 100,000 lbs., etc. As he points out, the equivalents of a system of graduated carload rates are in effect on the railways of Europe. In England lower rates are made for 2-ton and 4-ton lots than for goods moving in smaller quantities. On the German state railways lower rates are made for 5-ton lots than for smaller shipments, and for 10-ton lots than for 5-ton lots, a 10-ton lot in Germany being regarded as a carload.

The suggestion that graduated minimum weights could be advantageously adopted by the railways of this country merits the most serious consideration. In fact, it has been considered by some very eminent and practical railway traffic officials, but most of them have feared to advocate it lest they might be criticized as "theorists." It seems highly probable that if the best minds of the railways and the industrial and commercial interests should investigate the subject in a co-operative and constructive spirit some comprehensive plan could be worked out that would be mutually advantageous to them and also of great public benefit. The fact is, that the carload, and not the ton, is the true unit of cost in freight transportation, and it makes very little difference what the rate for 100 lbs. or per ton is if the earnings per car mile are satisfactory. A railway had a great deal better have coal traffic which will move in carloads of 100,000 lbs. at 4 mills per ton mile than dry goods that will move in carloads of only 15,000 lbs. at a rate of 2 cents per ton mile. In the former case the earnings per car mile will be 20 cents; in the latter case only 15 cents. A railway may get rich hauling coal in large quantities at 4 mills per ton mile; but it will hardly get rich hauling dry goods at a rate several times as high. This simple illustration suggests how vitally important it is to use every resource to secure the heaviest practicable loading of cars.

The subject of minimum weights has always been handled by the traffic department of the railroads. It is both a traffic and an operating problem. The rate per ton mile charged ought to be related to the minimum weight, and rates are a traffic matter. On the minimum weights applied will largely depend the average loading per car secured; on the loading secured will largely depend the economy of operation; and economy of operation is an operating matter. Therefore, it would seem that the operating and traffic departments might well appoint a joint committee to take up with a committee representing the shipping interests of the country the problem of securing heavier loading of cars in all of its phases. This matter is one to which the American Railway Association might very well give attention when it meets in Chicago next month. Undoubtedly the railways alone could do much to increase the loading of cars; but to secure the greatest practicable results they must have the co-operation of the shippers; and in order to secure the co-operation of the shippers they must make it worth the while of the shippers to co-operate.

**ATCHISON, TOPEKA & SANTA FE.**

**T**HE Atchison, Topeka & Santa Fe is in many respects typical of the better managed railroads of the West. Operating 10,750 miles of road, it earns between ten and eleven thousand dollars per mile. It operates on about a 66 per cent. basis, and within the system are comprised all the varieties of western railroad conditions. It has its heavy traffic density main lines built with the highest modern standards and worked most of the time close to capacity. It also has lines on which there is almost no local traffic but with heavy through business, which, in their present condition, are also being worked about to capacity. In addition it has its full share of branch line mileage on which the present service is probably more adequate than could be justified entirely by present earning capacity.

In 1913 total operating revenue amounted to \$116,900,000, which is the largest revenue in the history of the company and is greater than the 1912 revenue by more than \$9,000,000. On the other hand, expenses amounted to \$77,640,000, or about

holders, has made the Atchison credit high and on an unusually broad stable base.

The property has not, like the Southern Pacific, had a long unbroken record of huge amounts of money taken from profit and put in as further investment; but the Southern Pacific is not typical of American railroads any more than the Delaware, Lackawanna & Western is.

The operating gains in the effective use of the plant have not been as striking over a series of years on the Santa Fe as they have on the Southern Pacific. The average train load in 1912 on the Santa Fe, including company freight, was 400 tons. This is an increase over 1908 of 6 per cent., and compares with an average train load on the Southern Pacific of 456 tons, in the strike year 1912, an increase over 1908 of 13 per cent. On the other hand, the gains made on the Santa Fe in 1913 over 1912 are particularly good. The average train load was over 6 per cent. greater in 1913 than in 1912. Car loading increased 3.24 per cent.; and while total ton mileage of freight increased

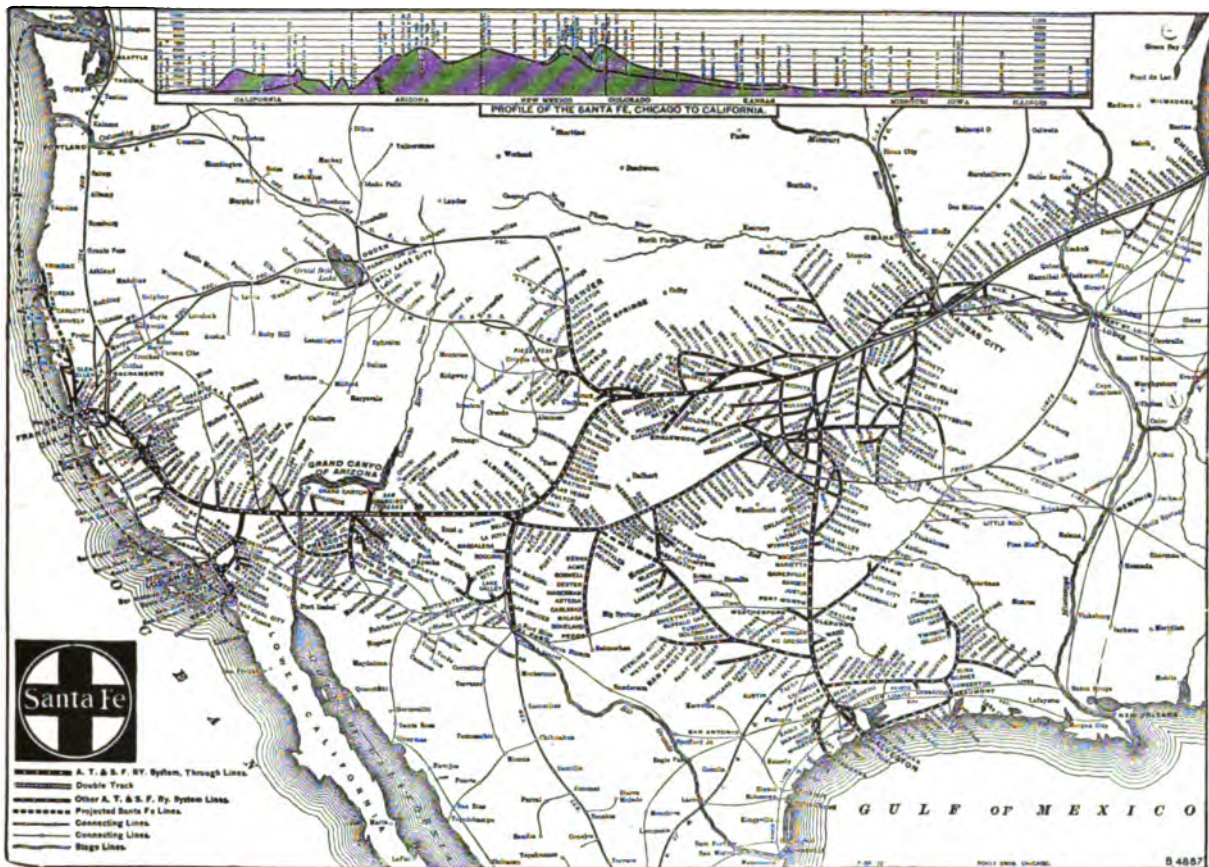

**The Atchison, Topeka & Santa Fe.**

\$6,400,000 more than in 1912, and of the increase, all but about \$1,400,000 was in maintenance. The table at the end of these remarks shows in more detail the operations in 1913 as compared with 1912, and it will be noted that although the company had a surplus, after the payment of dividends, of about \$6,000,000 in 1913, as compared with less than \$4,000,000 in 1912, all of this surplus in 1913 as well as in 1912 was put into the property as further capital investment. In all there was \$18,394,000 additional investment made in the property in 1913.

The Atchison is a conservatively capitalized property with an unusually high credit. It passed through a receivership in 1896 and since then has been both well managed and conservatively financed. The fact that control is held by no one group of capitalists; that its securities are widely distributed among comparatively small investors; that the price of its securities has never been open to the suspicion of being juggled; and that it has been managed solely in the interest of all the security

9.03 per cent., freight car mileage increased 5.49 per cent., and freight and mixed train mileage 2.50 per cent. The Santa Fe has always stood for progress, although possibly at times this progress took the form of experiment, which was not wholly successful. If one could spend two or three days with every superintendent on the Santa Fe it is not too much to say that he would get an almost overwhelming idea of the needs of the property. It is characteristic of American railroad superintendents to always keep a pet project or two ahead for their division; but on the Santa Fe these pet projects for betterments have been accumulating for years, notwithstanding the fact that very large sums have been and are being spent for betterments that cannot be postponed. In other words, high as has been the standard of maintenance and large as have been the capital expenditures these latter have not been large enough.

President Ripley strikes a solemn note of warning in the Atchison report for the fiscal year ended June 30, 1913, which

is well worth the most serious consideration. Mr. Ripley says: "The growth of the business of your company, and also the increased efficiency are due principally to the very large expenditures (over \$270,000,000) which have been made in the extension and improvement of the property since January 1, 1896. In order to make such expenditures your company has raised since 1896 over \$217,000,000 of "new money" by the sale of bonds which are now outstanding or which (in the case of many of the convertible bonds issued) are represented by common stock now outstanding. The following statement shows, for each year, the amount of investment, the amount of net income applicable to bond interest, dividends, improvement of property and strengthening of credit, and the rate of return which such net income represents on the amount of the investment.

Year ending June 30th.	Property Investment.*	Income applicable to bond interest, dividends, improvement of property and strengthening of credit.†	Per cent. Income of Property Investment.
1896 (6 months) ..	\$372,104,262.77	\$2,432,870.06	.65
1897 .....	387,957,477.68	6,070,364.45	1.57
1898 .....	392,169,842.02	8,871,947.26	2.26
1899 .....	399,527,444.30	11,409,315.36	2.86
1900 .....	407,187,811.22	17,064,850.91	4.19
1901 .....	419,541,440.17	21,196,714.38	5.05
1902 .....	439,911,035.33	23,921,018.14	5.44
1903 .....	454,290,057.89	23,032,814.51	5.07
1904 .....	466,273,139.34	24,778,541.31	5.31
1905 .....	473,020,998.79	21,353,856.15	4.51
1906 .....	496,782,342.35	28,355,393.34	5.71
1907 .....	519,004,129.48	32,724,274.07	6.31
1908 .....	541,727,328.96	25,633,510.34	4.73
1909 .....	548,251,270.97	33,523,437.28	6.11
1910 .....	579,793,768.23	32,387,712.39	5.58
1911 .....	609,287,764.18	34,102,511.86	5.59
1912 .....	621,869,989.29	33,321,100.75	5.36
1913 .....	640,263,756.10	36,086,013.36	5.64
Annual average ..	\$487,164,658.84	\$23,786,642.62	4.88

\*The amounts above shown as "Property Investment" do not include anything for necessary working capital such as materials and supplies and cash. Ordinarily such necessary working capital considerably exceeds \$35,000,000. In the years 1901 to 1908 the "Property Investment" was reduced by "writing off" sums aggregating \$21,066,685.78, which sums are excluded from the "Property Investment," as above stated. In the years 1910 to 1913 sums aggregating \$16,077,421.48, consisting of depreciation of equipment accrued pursuant to the ruling of the Interstate Commerce Commission, have been deducted from the amounts shown as "Property Investment" and are excluded in the above statement. †The "Income" shown above is determined after allowing for adjustments made through profit and loss.

"The last statement emphasizes the striking fact that the earnings on the entire investment are now not much in excess of 5 per cent. per annum and continue on that basis notwithstanding the increase in efficiency and the increase in the volume of traffic. It may be explained that the ability of your company under such circumstances to pay 6 per cent. on the common stock is due to the fact that it pays an average of substantially less than 5 per cent. on its bonded debt, and, indeed, much of the bonded debt was created when money could be borrowed at or near 4 per cent.

"The very moderate return which is realized upon the investment, especially when considered in connection with the increased rates which must now be paid for new capital, indicates that in order to preserve and strengthen the credit of even the most successful railroad companies, to the end that they may be able to develop and improve their property so as to promote the public safety and the public convenience, the government ought to increase, rather than to reduce still further, the rates for transportation and ought to be exceedingly slow about increasing still further the costs of operation. It is very clear from the foregoing statement that the mere growth of business and the mere increase in efficiency will not afford adequate protection against further reductions in rates for transportation and further increases in costs, especially in view of the increasing rates demanded for the use of money."

A warning such as this, coming from the president of one of the greatest American railroad systems, who represents no group of capitalists; who has no interests but the interests of his company, its security holders and its patrons to serve; who has managed this great property in such a way that Atchison credit abroad has a reputation enjoyed by few other American railroads, and in such a way that Santa Fe passenger service is

known pretty well all over the world, merits a very careful consideration both by the Interstate Commerce Commission and by the president of the United States.

The Atchison is in a strong position as regards cash. There are no bills or loans payable and the company has on hand \$30,096,000 cash.

The following table shows the principal figures for operation in 1913 as compared with 1912:

	1913.	1912.
Average mileage operated.....	10,750	10,628
Freight revenue .....	\$78,190,923	\$71,629,575
Passenger revenue .....	29,425,922	27,453,525
Total operating revenues .....	116,896,252	107,752,360
Maint. of way and structures...	18,054,413	16,076,834
Maint. of equipment.....	19,415,225	16,521,231
Traffic expenses .....	2,455,785	2,416,746
Transportation expenses .....	35,135,649	33,733,667
General expenses .....	2,581,463	2,524,724
Total operating expenses.....	77,642,535	71,273,203
Taxes .....	4,662,152	4,206,454
Operating income .....	34,591,565	32,272,703
Gross income .....	37,107,189	34,842,671
Net income .....	22,153,734	19,660,241
Dividends .....	16,107,470	15,876,875
Appropriations for additions and betterments .....	5,574,434	3,300,000
Fuel reserve .....	461,105	396,960

MINNEAPOLIS, ST. PAUL & SAULT STE. MARIE.

THE Minneapolis, St. Paul & Sault Ste. Marie, which is controlled by the Canadian Pacific and which itself owns the majority stock of the Wisconsin Central and operates this property as its Chicago division, earned gross in 1913 \$32,300,000, by far the largest earnings in the company's history. Of these total earnings \$21,410,000 was earned on the Soo proper and \$10,890,000 on the Chicago division. This is a gain over 1912 of \$4,300,000 on the Soo and \$1,300,000 on the Chicago division. The Soo earned in 1913 \$7,344 per mile, and the Chicago division \$9,887 per mile, and the properties are operated on a 56.5 and 66.2 per cent. basis respectively.

The Soo runs through a country that is largely dependent on railroad facilities for its development, and the company has in the past pursued a liberal policy of extension as well as betterment. At present, however, the company is simply completing the work of extension that it had mapped out some years before and cannot interest capital in any further plans for extension. This is in marked contrast to the situation in Canada, where roads which the country needs, or thinks it needs, are being built so largely with government aid in the shape of guarantees, land grants, or otherwise.

The Soo itself has had much the same experience in regard to expenses as other roads in the United States. Both maintenance of way and maintenance of equipment charges were made more liberally in 1913 because of larger business and more revenue with which to meet them, as well as, of course, greater wear and tear on the plant due to the larger business handled. Transportation expenses in 1913 amounted to \$6,090,000 on the Soo as against \$4,990,000 in 1912, and on the Wisconsin Central to \$4,010,000 as compared with \$3,700,000 in 1912. On the Soo 2,073,000,000 ton miles were carried in 1913, as against 1,653,000,000 in 1912. The average haul was just about the same in 1913 as in 1912, 267 miles. With this increase in freight traffic and an increase in the number of passengers carried one mile from 169,000,000 in 1912 to 198,000,000 in 1913, there was an increase in the total revenue locomotive mileage of about 1,300,000; the total in 1913 of revenue locomotive mileage being 9,639,000.

Both the Soo and its Chicago line have heavy freight train loading for granger roads, and the Soo especially made a large gain in 1913 over 1912. The freight train load in 1913 on the Soo was 422 tons as compared with 396 tons the year before, and on the Chicago division the train load in 1913 was 470 tons as against 446 tons the year before. Car loading also was better in 1913 on the Soo, the average per loaded car being 18.18 tons in 1912 and 19.23 tons in 1913.

The changes in the tonnage of various commodities carried on the Soo speak eloquently of the development of the territory. In 1911 36.11 per cent. of the total tonnage was lumber, as against 27.43

per cent. in 1913, while on the other hand the percentage of grain in 1911 was 12.52 per cent., as against 23.25 per cent. in 1913; and whereas the tonnage of miscellaneous carload business was 384,000 tons, or 7.66 per cent. of the total in 1911, this had increased in 1913 to 719,900 tons, or a total of 9.28 per cent. of all revenue tonnage. Neither the Soo nor its Chicago line carries much coal; but the Chicago division in 1913 handled 1,227,000 tons of ore. In 1911 ore furnished but 12.52 per cent. of the total tonnage, while in 1913 this business has grown until it averaged 1,227,000 tons, or 18.09 per cent. of its total tonnage. Both the Soo and its Chicago line get fair but not large ton mile receipts. In 1913 the Soo got 7.40 mills, comparing with 7.22 mills in 1912. The Chicago division handled 1,260,000,000 ton miles, an increase of 19 per cent.; the average receipts being 6.47 mills as against 6.70 mills in 1912.

President Pennington calls attention to the development of the Cuyuna iron range. The first shipments on the branch running into this territory were in 1912, and in that year about 300,000 tons of ore were shipped. This year about 1,000,000 tons have been shipped, and the present prospects are for a shipment in the fiscal year ending June 30, 1914, of 3,000,000 tons or over.

The balance sheets of both companies (they are not combined in the annual report) show no loans and bills payable, and the Soo has on hand \$3,357,000 cash, and the Wisconsin Central \$1,336,000.

The following table shows the principal figures for operation

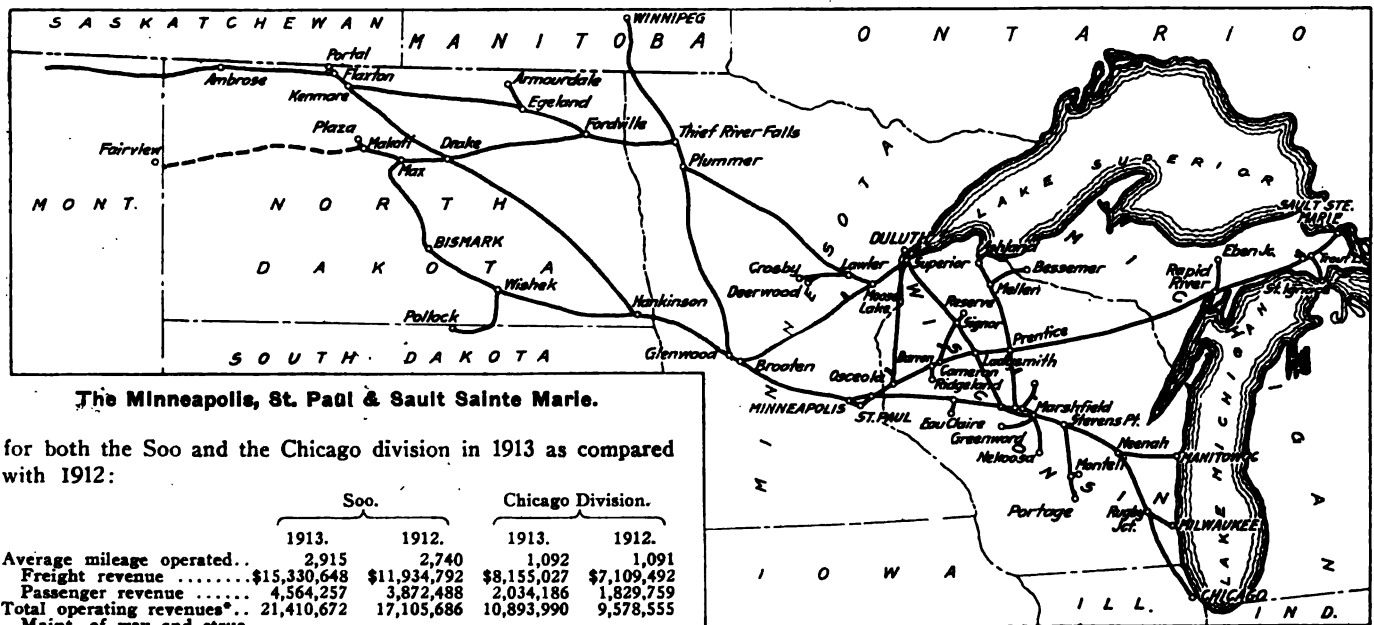

The Minneapolis, St. Paul & Sault Sainte Marie.

for both the Soo and the Chicago division in 1913 as compared with 1912:

	Soo.		Chicago Division.	
	1913.	1912.	1913.	1912.
Average mileage operated..	2,915	2,740	1,092	1,091
Freight revenue .....	\$15,330,648	\$11,934,792	\$8,155,027	\$7,109,492
Passenger revenue .....	4,564,257	3,872,488	2,034,186	1,829,759
Total operating revenues*	21,410,672	17,105,686	10,893,990	9,578,555
Maint. of way and structures	2,292,993	1,697,402	1,193,096	1,039,114
Maint. of equipment .....	2,603,669	2,027,240	1,375,307	1,322,066
Traffic expenses .....	357,518	295,361	289,537	268,216
Transportation expenses..	6,090,411	4,985,876	4,005,944	3,696,601
General expenses .....	458,418	336,365	224,364	214,288
Total operating expenses*	12,096,215	9,586,408	7,208,299	6,836,883
Taxes .....	1,298,967	1,123,136	465,157	418,781
Operating income .....	8,015,490	6,396,142	3,220,535	2,522,891
Gross income .....	8,886,541	7,454,378	3,269,573	2,563,675
Net income .....	5,527,415	4,224,290	1,093,350	504,650
Dividends .....	2,646,714	2,417,037	450,688	225,344
Surplus .....	2,880,701	1,807,253	642,662	279,306

\*This includes outside operations.

NEW BOOKS.

*Transformer Practice.* By William T. Taylor. Size, 9 in. x 12 in. 278 pages. 190 illustrations. Cloth binding. Published by the McGraw-Hill Co., New York. Price \$2.50.

The first edition of "Transformer Practice" was published in 1908, and treated principally of the connection, installation and operation of transformers. The second edition, which has just appeared, has been entirely rewritten and enlarged with a view to keeping the book up-to-date in all methods of handling transformers and static induction apparatus. The book is particularly intended to help operating engineers to solve certain difficulties

by the use of temporary arrangements when the proper apparatus is lacking.

*Wright on Building Arbitrations.* By G. Alexander Wright. Size 6 in. x 9 in., 48 pages, paper cover. Published by the author, at 571 California street, San Francisco, Cal. Price, \$1.

A manual under the above title was published by Mr. Wright in May, 1894, and the present pamphlet is an elaboration of this earlier work, including data of interest to building arbitrators and a number of forms for their use. The principles of arbitration are set forth in the book and the statutory requirements necessary to the proper conduct of the duties of arbitrator or umpire are explained.

*The Strength of I-Beams in Flexure.* By Herbert F. Moore. Bulletin No. 68, University of Illinois Engineering Experiment Station. Size 6 in. x 9 in., 40 pages, 15 illustrations, paper bound. Copies may be secured upon application to C. R. Richards, acting director of the Engineering Experiment Station, Urbana, Ill.

Although it is customary in deriving the formulae for determining the load carrying capacity of I-beams under transverse loads, to consider only direct flexural action, it is known that such beams are also subject to sidewise buckling and web stresses which may materially influence failure. Very few transverse tests of I-beams have been made and little definite information has been at hand as to the action of beams under such stresses. Bulletin No. 68 discusses and tabulates the results of tests of

I-beams at the University of Illinois and elsewhere with particular reference to these secondary effects. The conclusion is drawn that in considering the strength of beams in flexure the yield-point of the material should be regarded as the ultimate fiber stress for the beam. Suggested formulae are included for calculating the strength against sidewise buckling and against web failure.

*Diagram Giving Stresses in Beams.* By G. R. Thayer, Assistant Professor of Structural Design, Carnegie Institute of Technology. Size 7 1/2 in. x 11 1/2 in. Published by D. Van Nostrand Co., New York. Price, 20 cents.

A compact diagram for use in designing beams such as that prepared by Mr. Thayer should be found serviceable in many designing offices. The technical man often finds such a table a time saver, and by its use the non-technical man may obtain satisfactory results. It is intended to show the required dimensions of a beam for given loads and stresses, or for given moments and stresses; the section modulus required for given loadings, and stresses and the stresses caused in a given beam by a given load or by a given moment.



# WRECK CAUSED BY A BROKEN TIRE.

Fracture Caused by Thermal Cracks Which Developed in the Tread; Extracts from Report of the Bureau of Standards.

On January 7, 1913, there was a derailment of a passenger train on the Cleveland, Cincinnati, Chicago & St. Louis, near Stockwell, Ind., resulting in the death of 1 passenger and the injury of 66 passengers and 4 employees.

The investigation of this accident disclosed the fact that it was caused by a broken tire on one of the wheels of the forward truck of the baggage car, the second car from the locomotive, and arrangements were made with the Bureau of Standards, of the Department of Commerce, to have the broken tire examined for the purpose of ascertaining the cause of its breakage; this examination was conducted by James E. Howard. The following is extracted from Mr. Howard's report:

The train consisted of a locomotive and seven cars, and was proceeding from Cincinnati to Chicago. Six cars of the train were derailed, the locomotive and the mail car remaining on the track uninjured, the damage to the train and the

up. The contour lines were satisfactory at the time of derailment and it was not very much worn.

Eight 9/16 in. rivets were provided in the construction of the wheel to hold the tire against such an emergency as arose when this tire fractured. The total sectional area of these eight rivets was a little less than 2 sq. in. The two retaining rings, however, had a sectional area of about 60 sq. in. to resist an outward radial force taken either in tension on the body of the rings or shear of the inner lips. The tire was placed on the wheel center under shrinkage strains reported to range from one-eightieth inch to one-sixtieth inch per foot of diameter. The manufacturers heated the tire to a temperature of 450 deg. F., a very moderate heat in no way calculated to impair the properties of the steel, yet sufficiently high to permit assembling.

Under the maximum shrinkage above mentioned tires having the tensile properties of this one would not be strained

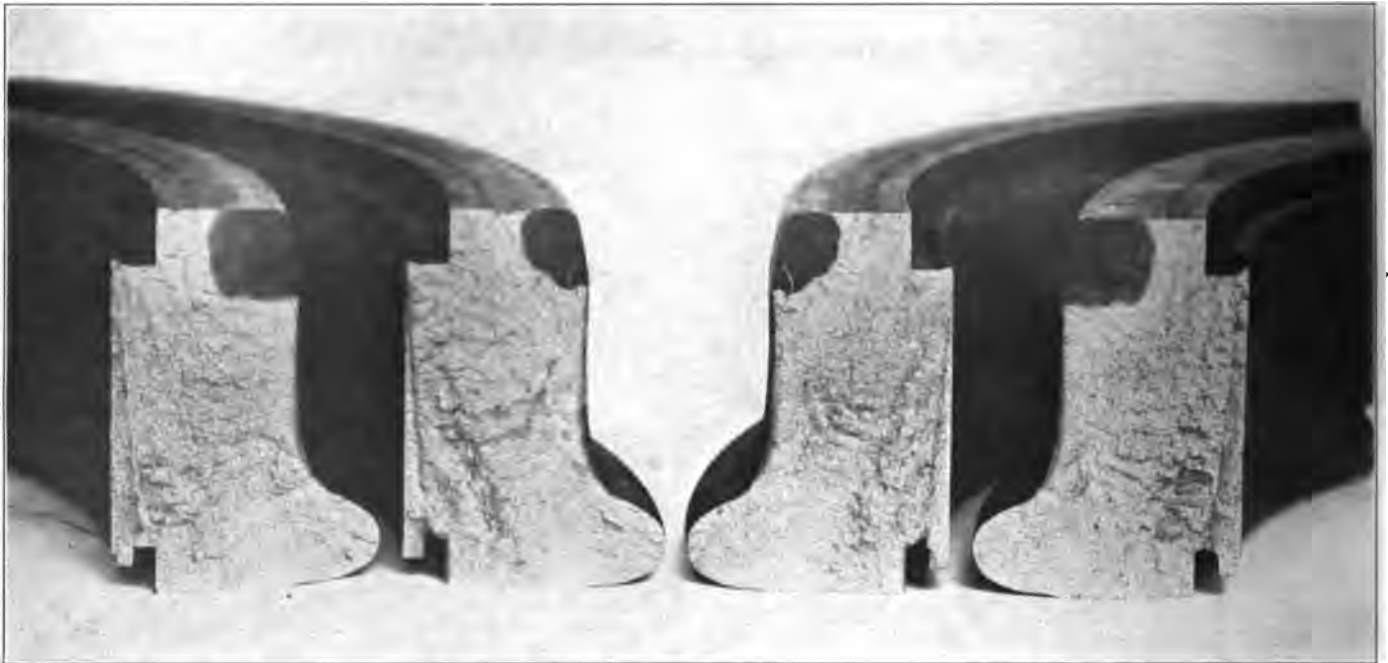

Thermal Cracks Which Developed in the Tire While in Service.

track occurring behind them. The baggage car, which was the second car in the train, was derailed to the right side of the track, turned end for end and faced toward the rear, and came to rest in a demolished condition. Its forward truck was five rail lengths to the rear, and also turned nearly end for end. The train was running at 55 or 60 miles an hour when the derailment occurred.

The character of the fracture in the tire was such that, while it is believed to have been the extension of a thermal crack previously existing, its development by stresses in the track and complete separation would take place very promptly when the final stage was reached. The shrinkage of the tire upon the wheel center was the chief element of strength, or resistance, which kept it in place when intact. When fractured this resistance was lost, and only the strength of the rivets of the retaining rings would then be available for holding it in place. The original thickness of the tire was  $3\frac{1}{2}$  in. and it was  $2\frac{9}{16}$  in. thick at the time of derailment. The total mileage made was 111,113 miles; the car was in the shop in March, 1912, and the tires were then trued

up to their elastic limits when assembled. Shrinkage strains, however, are variable factors under service conditions. They would change as the tire becomes worn. Cold rolling of the metal at the tread would have a tendency to modify the strains. The greatest factor in the case, however, is the application of the brakes. The tread is suddenly heated by the friction of the brake shoe and the tire expanded before the center is affected, no doubt causing wide fluctuations in the magnitude of the shrinkage strains.

Momentarily the tire may be left with very little shrinkage resistance when there is sudden application of the brakes, causing the tire to reach a high temperature before the wheel center becomes heated by conductivity. An increase in temperature of only 214 deg. above the temperature of the center should relieve the tire of a shrinkage of one-sixtieth inch per foot. At the immediate surface of the treads much higher temperatures are reached. Superficially the temperature is such as to throw off a shower of sparks between the tire and the brake shoe. The brake shoes are not infrequently heated until portions reach a blue color. Inter-

mittantly the shrinkage strains of tires must pass through wide fluctuations.

But the sudden heating of the treads of wheels and the attainment of high temperatures assume a more serious aspect than causing the temporary reduction of shrinkage resistance. Thermal cracks in the steel are formed in this manner, the presence of which is a menace to the integrity of the tire. Such thermal cracks are probably present in all brake shoes after they have been but a few hours in service. Occasionally thermal cracks are developed on the running surface of rails and are there known as "wheel burns." They are caused by the rapid cooling of intensely heated metal, where free contraction is resisted. They result from internal

service a wheel of this type in which thermal cracks have appeared would be a modification of the design of the wheel to the end that the element of safety is more amply provided for at a time when the shrinkage resistance between the tire and the wheel center is menaced.

Tensile tests and chemical analyses were made of the metal of this tire. One test piece was taken out in a radial direction, three test pieces tangentially; diameter of stems, 0.564 in.



Thermal Cracks on Face of Tire at Outer Edge of Tread.

strains of tension, the metal passing through a reversal of internal strains in their formation. The present tire exhibited on its tread many such thermal cracks, leading to the belief that the complete fracture of the tire was the direct consequence of their being present. One of the illustrations shows the outer end of the tire on which a number of cracks of pronounced size were visible. The location of those which measured one-half inch or more in length, 21 in number, is indicated by chalk marks. These cracks are shown again in the other illustrations. The outer edge of the tread is shown, on which appear a number of the longer cracks between which are numerous small ones. The wider and longer cracks were conspicuous, admitting of discovery upon inspection of the tire. Such cracks in steel have grave significance. They lead to early ultimate failure, especially when the causes which occasioned their formation are aided and combined with independent straining forces. The shrinkage strains are always present in the cold tire, and they alone would have a tendency to complete the fracture of the tire when a thermal crack had reached a certain stage of development.

Thermal cracks are usually progressive in their character, but the rate of their development, a question of deep interest in the case of a tire, does not admit of a definite answer. The depth to which they have penetrated the metal is uncertain. A risk is assumed in running a wheel of this type in which there are thermal cracks. A more satisfactory solution of the problem than judging of the degree of risk involved and reaching a decision as to when to remove from

TENSILE TESTS.

Mark.	Location.	Elastic limit per square inch (approximate). Pounds.	Tensile strength per square inch. Pounds.
A.....	Longitudinal, middle of tire .....	.....	110,400
B.....	Tangential, flange... ..	46,000	115,440
C.....	Tangential, middle, flange end .....	49,600	114,400
D.....	Tangential, outside end, 1 in. in from tread .....	.....	34,000

Mark.	Elongation. Per cent.	Contraction of area. Per cent.	Appearance of fracture.
A.....	5.5	.48	Fine granular.
B.....	15.3	18.4	Fine granular.
C.....	12.7	18.4	Fine granular.
D.....	None	None	Fractured at a thermal crack; 40 per cent. of surface discolored, 60 per cent. fine granular.

It appeared from the discolored portion of the fractured surface of specimen D that the thermal crack in the tire at the location of this specimen had penetrated the tire to a depth of 0.9 in.

CHEMICAL ANALYSES.

Mark.	Carbon.	Sulphur.	Phosphorus.	Manganese.	Silicon.
A.....	0.67	0.034	0.039	0.63	0.249
B.....	.70	.033	.043	.68	.254
C.....	.67	.026	.031	.67	.256
D.....	.65	.024	.041	.65	.255

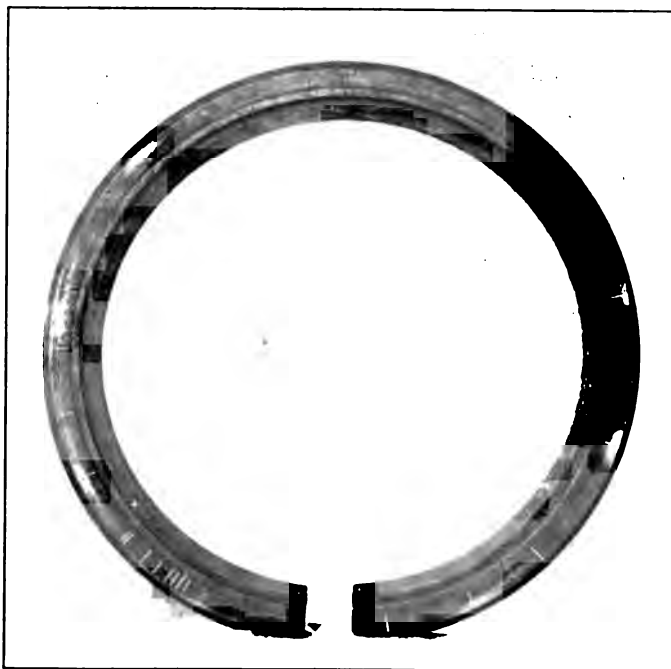

Broken Tire with Thermal Cracks 1/2 in. or More in Length Indicated by Chalk Marks.

The chips for chemical analysis came from the metal of the stems in turning the tensile specimens.

A further examination was made of the tire for the purpose of ascertaining the depth to which some of the thermal cracks had penetrated the metal. It was cut apart in a slotter, for convenience, and fractures made in two places by bending stresses, the surface of the tread being on the tension side of the bend. The cracks opened slightly, then fracture suddenly took place across the full section. Another of the il-

illustrations shows the progress which the cracks had made, while the tire was still in service, toward its ultimate complete fracture. Sections measuring  $1\frac{1}{8}$  in. x  $\frac{7}{8}$  in. and  $1\frac{1}{4}$  in. x  $1\frac{1}{4}$  in., respectively, which appear dark-colored on the engraving, mark the extent of these thermal cracks. They had reached nearly half through the thickness of the tire. The gravity of the case is well illustrated in the discolored portions of these surfaces. A series of photographic prints of this kind could properly be placed before car inspectors for their information and guidance.

Methods of inspection may need revision to meet current conditions of railway service, wherein is shown a marked tendency to increase the working stresses, and in so doing decrease the margin in strength remaining between them and the rupturing loads of the materials. Inspection for the discovery of occasional structural defects and inspection for noting approach to the limit of endurance of materials are quite distinct problems, the latter presenting great difficulties. High wheel loads and the introduction of high-speed brakes are factors in the present case.

The prevalence of thermal cracks in brake shoes is a conspicuous feature. They are present commonly, if not invariably, in shoes, even those which have been but a short time in service. The conditions of exposure are the same, for the time being, for the rubbing surfaces of the shoe and the tire. The same tendencies necessarily exist for the formation of thermal cracks in each, but more accentuated in the shoe.

In conclusion, it appears that the retaining rings and rivets in the construction of the wheel did not have adequate strength, shrinkage resistance having been lost, to hold the fractured tire on its wheel center.

That the fractured tire, insecurely held, was forced off its wheel center by side thrusts usual to train movements, thus precipitating the derailment.

That the fracture of the tire was occasioned by the presence of deep thermal cracks in the tread, one of which had separated the metal of the tire to a depth of one-half its thickness and had an area of over  $1\frac{1}{2}$  sq. in.

That these cracks were visible on the surface of the tread and the edge of the outer end of the tire.

That the formation and extension of these cracks was due to the heat generated under the brake shoe.

That adequate means should be employed to hold a tire of this type on its wheel center independent of shrinkage resistance.

That the presence of thermal cracks on the tread of a tire is sufficient cause for the removal of the wheel from service.

## MOVEMENT FOR THE SIMPLIFICATION OF TARIFFS.

Newman Erb, president of the Minneapolis & St. Louis, with a view to starting a movement for the improvement in the present methods of issuing and distributing tariffs, has written a letter to Chairman E. E. Clark of the Interstate Commerce Commission, suggesting a conference between the representatives of the carriers, the Interstate Commerce Commission, and representatives of commercial bodies in the effort to devise a better system. Chairman Clark having replied, promising the co-operation of the commission, Mr. Erb has written to the presidents or their executives of 36 of the principal railways of the United States, submitting his correspondence with Chairman Clark, and asking for their views on the subject to lay the foundation for a conference of the executives for the purpose of taking the steps suggested by Mr. Clark.

In his letter to the executives Mr. Erb says: "The simplification of tariffs to reduce the expenses incident to their issuance and distribution and at the same time so that shippers of or-

dinary intelligence may be able to understand them, is now, I think you will admit, a necessary step in the direction of economy and will be productive in creating and maintaining a spirit of co-operation between the railroads and the public."

Mr. Erb's letter to Chairman Clark was as follows:

"Your attention has no doubt been directed to the unscientific, unbusinesslike and expensive method of making, filing and distributing tariffs.

"The intention of Congress evidently was that tariffs should be deposited with the agent of every station to be accessible at all times to shippers, but under the present system it is almost impossible for shippers and agents of the railroads to inform themselves of the rates and classifications, and always with an unnecessary waste of time. I am quite sure that some better method of dealing with the issuance of tariffs can be devised, that will be more economical, simpler and more businesslike, and it occurred to me that it would be proper for a conference between the representatives of the carriers, with your commission and also the representatives of commercial bodies, with a view of devising a better system.

"I would like to have your views and the views of your commission, with a view of doing something, if anything can be done in that important direction."

To this Chairman Clark replied:

"I have yours of the 16th, and I am truly glad that you have become interested in the subject of simpler and more economical means and methods of providing railroad tariffs.

"I have given a great deal of personal attention to this subject because at the time the present law became effective the tariffs of the railroads were in a hopeless state of confusion. In our efforts to bring about conformity to the law and a system of tariffs from which the lawful rate could be determined, we met with much opposition, which was probably natural in view of the fact that we had to deal with so many different people, each of whom had, up to that time, been following his own personal ideas.

"I recognize fully that the system is still faulty and that the present practices involve what seem to be needless expenditures, and that the tariffs are still very complicated to those who are not practical tariff men and in some instances they are a puzzle to such experts.

"I think that conferences such as you suggest between representatives of the carriers and of the shippers or commercial bodies and with somebody representing the commission, with an idea of devising a better system, would be very helpful if entered into in a spirit of real desire to improve the conditions.

"I feel perfectly safe in saying that the commission would be glad to contribute anything it appropriately can in that direction. I think that if a committee representing the carriers could be provided and vested with some authority and endowed with some responsibility, means for greatly reducing the expenses and at the same time of improving and simplifying the tariffs could be devised.

"I do not want to be understood as suggesting undue haste, but if such a committee is provided, the members of it should be given to understand that some definite results are expected within a reasonable time."

RAILWAY ACTIVITY IN ARGENTINA.—The Argentine minister of public works has approved plans and specifications presented by the management of the state railways for necessary improvement works on the line from Cordoba to Cruz del Eje. The cost will be \$2,511,027, and it will be carried out when the state railway department has the necessary funds. The constitutional committee of the senate has reported favorably on the railway convention signed between Argentina and Paraguay on April 7 last; also on the protocol signed in Buenos Aires on June 17 last, between Argentina and Bolivia, for the immediate construction of a railway from Tupiza to La Quiaca.

# NEW O.-W. R. & N. TERMINAL AT SPOKANE.

Work Which is Now Under Way Includes Both Passenger Station and Freight Terminals at a Cost of Over \$3,000,000.

The Oregon-Washington Railroad & Navigation Company is now engaged in the construction of passenger and freight terminals at Spokane involving an expenditure of approximately \$3,000,000 in addition to an outlay of \$4,000,000 already spent for right of way. These terminals are the culmination of a project which started three years ago with the construction of a new line from Spokane south 102 miles to a connection with the O.-W. R. & N. at Ayer, on the south bank of the Snake river, forming a new short line with low grades from Spokane to Portland. This line was described in the *Railway Age Gazette* of May 31, 1912.

The most important single item in this development at

pleasing design. The entire front of the first story will be of cream colored stone, with a granite base surmounted with stone pilasters in front of the main waiting room and supporting a heavy stone cornice.

Four large entrance ways surmounted by a large ornamental copper glass-covered marquee provide access from Trent avenue to the large ticket and entrance lobby 168 ft. long and 33 ft. wide, with richly colored faience tile walls and mosaic floor. In the center of this room will be located the railroad and sleeping car ticket offices with telegraph and public telephones on each side. A direct entrance to the parcel and baggage checking counters will be immediately adjacent to the ticket office.



Perspective View of the New Spokane Station.

Spokane is the passenger station, the contract for the construction of which was let about a month ago. This station and the passenger yard between Monroe and Center streets is being built jointly with the Chicago, Milwaukee & St. Paul. It is reached directly from the west by the tracks of the O.-W. R. & N., and from the east by those of the St. Paul

When completed, the new passenger station will occupy the entire block between Stevens and Washington streets, and will be 300 ft. long x 58 ft. wide and 4 stories high. In addition, large baggage and express rooms will be built back under the tracks. This building alone is estimated to cost over \$575,000 exclusive of real estate, and in design, arrangement and equipment will compare favorably with the most modern stations. The French renaissance type of architecture has been adopted. The main body will be of tapestry or burlap brick laid in a

A passageway also leads from directly in front of the baggage and parcel checking counters to the street, and to carriages and hotel buses. The dining and lunch room is located at one end of the ticket concourse. At the opposite end is a barber shop with a stairway and elevator to the offices above.

Two broad stairways will lead from this lobby to the main waiting room on the floor above. This room will be 164 ft. long, 49 ft. wide and 28 ft. high, and will be lighted by seven large ornamental metal windows. The walls will be decorated with high wainscoting of faience tile and above this with decorated plaster, while the ceiling will be broken up with heavy ornamental beams. The smoking room will be located at one end of this waiting room and the women's rest room at the other.

Two large entrance ways will lead from the waiting room to a concourse 100 ft. long and 54 ft. wide, from which all

tracks will be reached by inclines and stairways, thus eliminating all crossing of tracks at grade. From the concourse, which is paneled with steel, incoming passengers can go directly to carriages and hotel buses, or to the waiting rooms.

luminated by concealed lights in the ceilings and massive indirect lighting pendants. Above the main waiting room are two additional floors which will be devoted to offices.

On the street level at one end of the building will be located

The passenger yard proper consists of a steel viaduct 2,200 ft. in length providing for 10 tracks at present. This viaduct

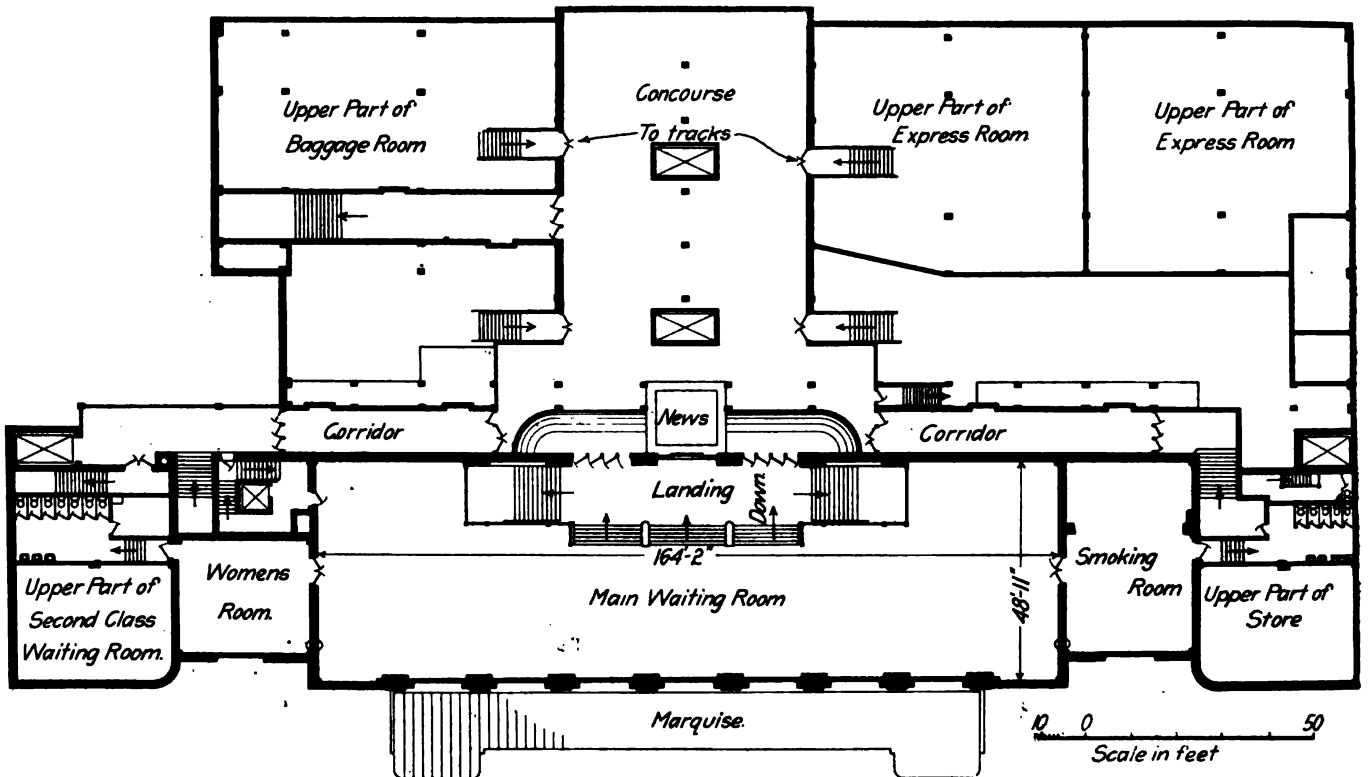

Main Waiting Room Floor Plan.

an emigrants' waiting room with a stairway leading to the track platform. A fully equipped hospital will also be installed. Steam heat for the buildings and for standing cars will be generated by a power plant in the basement. The building will be il-

luminated by concealed lights in the ceilings and massive indirect lighting pendants. Above the main waiting room are two additional floors which will be devoted to offices. The estimated cost of this work is \$842,000. Immediately at the west end of the passenger station a double track steel viaduct with a concrete deck will be

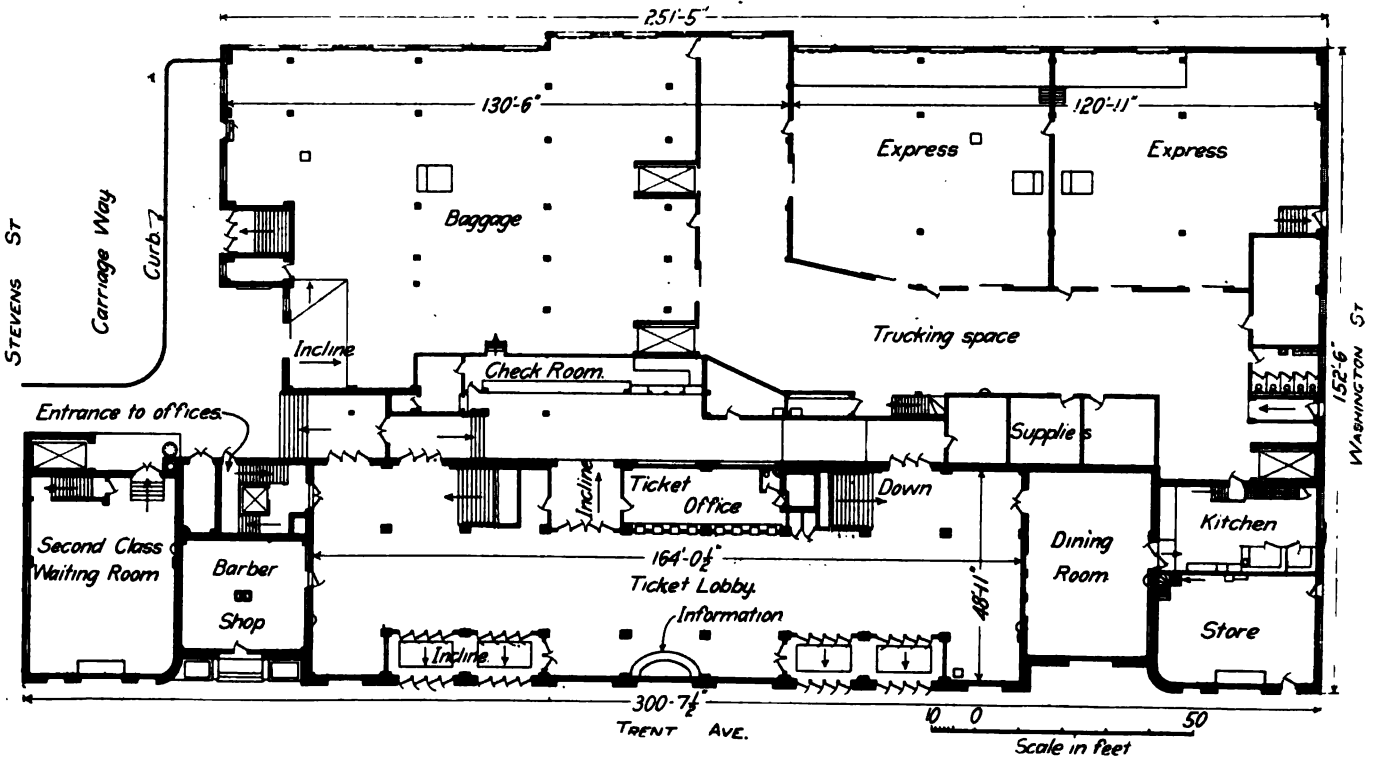

Street Floor Plan.

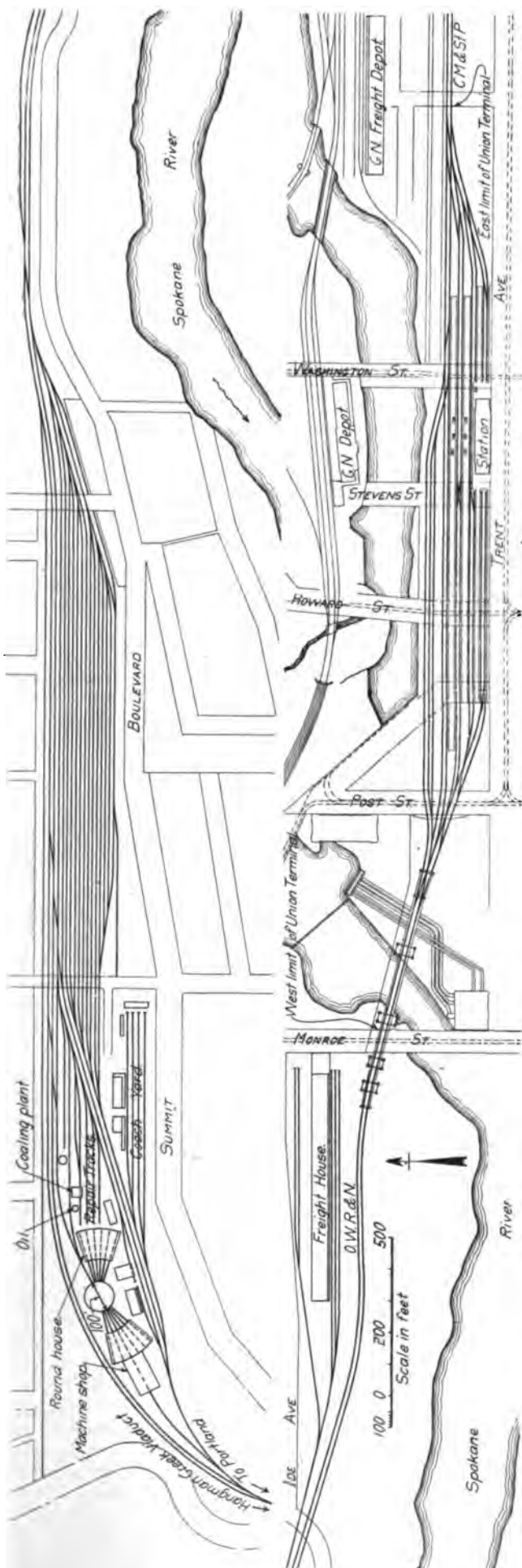

Track Layout of O. W. R. & N. Terminals at Spokane.

built across the Spokane river directly over the Spokane Falls and 164 ft. above the water. This viaduct will be 768 ft. 6 in. long and will also cross over the recently completed Monroe street concrete bridge of the city.

Between Monroe and Cedar streets will be located the local freight house, 50 ft. x 300 ft. in size, together with team tracks, house tracks and driveway. West of this point will be located a 14-track classification yard with roundhouse, machine shop, storehouse, coal, oil and ash handling equipment, etc. This portion of the line will require over 1,000,000 cu. yds. of filling and will cross all streets overhead. At the west end of this development there is nearing completion, the Hangman creek-Spokane river viaduct, 2,996 ft. long and 176 ft. above the water. The main line is double tracked throughout from the east end of this viaduct into the station.

The designs for this terminal were worked out under the direction of John D. Isaacs, formerly consulting engineer of the Oregon-Washington Railroad & Navigation Company, and F. L. Pitman, formerly chief engineer. The actual construction work is now being carried out under the direction of E. E. Adams, consulting engineer, and J. R. Holman, chief engineer.

### POWDERED COAL AS FUEL.\*

By W. S. QUIGLEY,

Quigley Furnace & Foundry Company.

In a recent article published by the Department of Industrial Research of the University of Pittsburgh, it is stated: "At the present time Pittsburgh burns in the neighborhood of 15,000,000 tons of coal annually, the cost of which is about \$19,000,000, and it has been estimated on the basis of efficiency tests that there is a loss of \$4,000,000 annually which could be saved by proper furnace operation."

In reality powdered coal means conservation of our coal supply. Powdered coal as a fuel is not new, the advantages of that method of firing having been fully recognized in the early Fifties, but it was not a simple matter to burn it successfully, as the enormous sums expended and lost in experimenting with it have proved. We have installed plants capable of handling over 240 tons per day and are now installing plants capable of milling, distributing and burning over 740 tons per day in metallurgical furnaces.

For best results powdered coal must be dry and fine—dry means not over 0.5 per cent. of moisture (and I might here state that in addition to the advantages in burning, considerably less power is required to properly pulverize dry coal) and fine means that 93 to 95 per cent. should pass a 100 mesh sieve or 80 to 85 per cent a 200 mesh sieve. In that state the particles are so finely divided that each one in a proper burning apparatus is surrounded by the necessary amount of air for combustion and thereby liberates the entire fuel energy of the coal at once. Being finely powdered, the volatile gases ignite the instant the fuel enters the combustion chamber and the fixed carbon is consumed while in suspension by the heat from the gases, the resultant flame to a casual observer resembling that of either oil or gas. The fire is under absolute control and is not dependent on stack draft or atmospheric conditions. The entire inflammable portion of the coal is converted into heat without any loss whatever.

The following roughly constitutes a plant for properly preparing and burning powdered coal: A coal milling building located at a place convenient to the coal supply from which the coal can be delivered to a crusher and reduced to the size required for pulverizing. From the crusher it must be elevated to a crushed coal storage bin; from the storage bin it is sent to the dryer and then elevated to the dried coal bin. From the dried coal bin it is delivered to the pulverizer, then elevated again to the pulverized coal bin, and thence

\*Presented at the recent convention of the American Foundrymen's Association.

it is delivered to the distributing conveyors which supply the individual hoppers located near the furnaces, from which the coal must be fed.

The controller or device which regulates the coal fed to the burners must be flexible, as it determines the amount of coal which can be delivered or supplied to the burner. One type of controller is fastened to the bottom of a specially designed hopper or bin. It consists of two screws, the upper propelling the coal forward to a point where it falls in a steady stream past the opening through which it is forced to the burner by a jet of low pressure air, the excess coal falling to the lower screw of greater pitch, which returns the overflow to the base of the hopper. This construction makes it impossible to jam, practically fool proof and permits any portion of the falling stream, up to the capacity of the upper screw, being used by simply turning on more or less of the air—we term it controller air, it being less than one-seventh of the air required for combustion. A separate supply of air of a much lower pressure is introduced at the burner for combustion.

The controller screws are operated by variable or constant speed motors as conditions require. On small furnaces when a more or less uniform class of work is done, such as rod heating, small forgings, nut and spike work, etc., the controllers are speeded to give the maximum amount of fuel required to heat the furnaces and the operator can not exceed that amount. On larger furnaces, such as open hearth, continuous billet, reheating, etc., a variable speed motor or speed changing device is used to give a wide range of operations. Furnace operators soon become accustomed to the new fuel and have no difficulty in regulating the furnaces to suit their requirements.

The current of controller air serves a double purpose; it not only forces the coal to the burner, but in picking up the coal it is mixed with it so that upon entering the burner it expands into a cloud, which mixes readily with the combustion air and bursts into a clean flame, the length of which can be changed by adjusting the burner and varying the proportions of the furnaces to suit conditions. The volatile content of the coal also has a material effect upon the length and nature of the flame. The fires are usually started by placing oily waste or wood in front of the burner much the same as starting oil or gas fires, although on small furnaces where oil systems are already installed it is very convenient to use oil for heating the furnace 10 or 15 minutes before the coal is turned on.

In a four-door forge furnace having a chamber about 6 ft. wide x 18 ft. long used for heating engine frames, etc., in the hammer shop of the American Locomotive Company, the fuel consumption hand fired with bituminous coal was 650 lbs. per hour. With powdered coal it consumes but 350 lbs. per hour and heats 20 per cent. faster and this amount will be reduced as the heaters become more familiar with the new fuel and realize that the smoky flame they were accustomed to for so many years is not necessary. In addition the special grade of blacksmith coal formerly used cost about 35 cents more per ton.

A report from the Lima Locomotive Works shows that a large furnace for supplying a 6,000 lb. hammer and having a chamber 7 ft. 2 in. x 15 ft. 3 in., started cold at 8.15 reached a temperature of 2,200 deg. F. at 9.15 and 2,500 deg. F. at 9.45, which compares favorably with oil or gas practice. The coal used is bituminous run of mine, 34.7 per cent. volatile, having a heating value of 14,000 B. t. u. per pound, and costs \$2.25 delivered at Lima. Allowing 50 cents per ton for the cost of pulverizing and distributing, which is a fair average, they get 31,360,000 B. t. u. for \$2.75, or 114,036 B. t. u. for one cent as against 27,282 B. t. u. for one cent with oil, the present cost being 47½ cents per gallon with no possibility of making a contract at that price.

Allowing 80 per cent. efficiency and 50 cents per ton for

the cost of gasifying a ton of coal, both of which figures are in the producer's favor, average practice considered, the comparison between oil, producer gas and powdered coal based on cost of fuel in Lima, Ohio, would be:

Fuel oil .....	27,282 B. t. u. for one cent.
Producer gas .....	91,228 B. t. u. for one cent.
Powdered coal .....	114,036 B. t. u. for one cent.

The usual fuel consumption throughout the country is one pound of pig iron puddled per pound of coal, although considerably more is used in some plants, one visited a few days ago claiming the consumption to be 1.3 tons of coal per ton of iron. At the plant of the American Iron & Steel Company, using powdered coal, records as low as 1,083 lbs. per ton have been made while a fair average fuel consumption is 1,185 lbs. of coal per gross ton of muck bar made. The waste heat is utilized in off heat boilers mounted over the furnaces and to preheat the air for combustion to about 600 deg. F., which adds about 20 per cent. to the economy. As compared with producer gas the cost of installation is less. High temperature can be readily obtained without regeneration, and the loss in gasifying is eliminated.

It is not necessary to use cheap or poor grades of coal in order to make savings. The analysis of the fuel and the heating value should be considered, a high volatile, low ash and low sulphur being the most desirable.

## PURE DRINKING WATER ON THE SOUTHERN PACIFIC.

The bulletin of the passenger department of the Southern Pacific contains a description of the methods used to provide pure drinking water for passenger trains on that road. The details apply to the Los Angeles division, but similar methods are applied on other parts of the system.

Los Angeles is the principal icing place for outgoing trains of the coast and valley lines, and the line leading to El Paso, Tex. Water is purchased from the city, and the ice is made from distilled water. After being sawed it is washed, placed in a clean covered cart and carried to the coolers. It is handled by men clad in white duck, with white rubber gloves, and they are required to change their garb frequently and to present a neat appearance at all times. The cart is steam cleaned at intervals, and the water coolers are steam cleaned and sterilized before the train departs. This is the custom at all the most important icing points. At Indio the water supply is artesian, and remarkably pure. In the Imperial valley the only drinking water is that from canals supplied by the Colorado river. To provide passenger trains and waiting rooms in this valley water is carried in cans from Mecca, where the artesian flow is reputed to be the purest in the state. The 20-gal. cans in which the water is carried are frequently sterilized, and ice is handled by gloved hands, in buckets and by the use of tongs. Every six months the water supply is analyzed and a certificate of the purity is issued by the proper health officer. Ice is certified in the same way.

For the use of passengers pasteboard drinking cups are on sale on all trains by the news company, and by all agents at passenger stations. The Crane automatic drinking fountain has been installed at Los Angeles and 15 other important stations. In these fountains coiled pipes are iced, and the water made cool as it passes through them.

**RUSSIAN RAILWAY CONSTRUCTION.**—The Russian minister of ways and communications will shortly undertake, at the expense of the State, the construction of a railway line from Meref to Cherson. It is announced that the Russian minister of commerce regards favorably the project for the construction of a railway from the Nadejdinsk works to Archangelsk, in view of the exploitation of the naphtha area of Ouchta.

# CONDITIONS IN THE INVESTMENT WORLD.\*

Expansion of Industrial Effort and National Tendency to Excessive Borrowing Have Deteriorated Character of Bonds.

BY JAMES J. HILL.

The superior efficiency of wealth united under corporate management over money employed in small sums by individuals has concentrated investment in corporations. Investment securities are mostly stocks and bonds. The former entitle the holder to a proportionate voice in the management of the concern, and to a share in the profits or a responsibility for the losses. The place of the share of stock has changed little. The bond has been subject to alteration and dilution. With a great increase in total volume has come a depreciation of many of them in both reputation and quality.

A corporate bond is a lien on the property that it covers. The bondholder being a contingent owner, and taking precedence of the stockholder, the bond had a special value of its own. The very name became a synonym for security. And until comparatively recently nothing has happened to impair this confidence, just shown to be so essential an element in credit. A bond could become a losing investment only in the case of so large an issue or so serious a depreciation in the property that its total proceeds would not equal the total of outstanding bonds. Formerly this was a possibility too remote to be taken into consideration in the case of legitimate business concerns.

It happened, perhaps inevitably, because of the increase of capital for investment, the increase of vision and of daring among borrowers, and the assured reputation of the bond, that its standing was slowly sapped. The repudiation of debts by some American states gave public credit a heavy blow. Panics and reorganizations compelled a closer scrutiny of corporate securities. But the main cause of such deterioration as the bond has suffered is the putting out under that name of a great volume of paper promises which are not entitled to it. And this is partly the effect of the excessive borrowing and spending of our day, and partly that of an expansion of industrial effort and an inflation of the capital of industrial enterprises which have often raised the total of bond issues, heretofore representing the value of the property under the hammer, to approximately the figure that would once have covered stock and bonds combined. In fact, the stock of more than one pretentious concern would have nothing behind it if the bondholders had to be paid off. Nor could the latter themselves hope to receive dollar for dollar on a forced sale. The dangerous proportions of this abuse of credit are shown in a recent address by Joseph T. Talbert, vice-president of the National City Bank. He said: "If we take the ten years from January, 1904, to January, 1913, inclusive, and tabulate the comptroller's reports for national banks, the first call of the year, we find that loans increased from \$3,511,000,000 to \$6,147,000,000—a net increase of \$2,636,000,000, or 75 per cent. During the same period the deposits of these banks increased from \$4,789,000,000 to \$8,361,000,000—a net increase of \$3,572,000,000, or 74.6 per cent. During the same period the investments in railroad, municipal, public service, industrial and miscellaneous bonds increased from \$555,000,000 to \$1,057,000,000, or 90.4 per cent. These figures are dazzling and they are so large as to become confusing. Taking a shorter period and beginning with the year before the panic of 1907, we find that the net increase in the loans of national banks is slightly over \$2,000,000,000, or nearly 50 per cent. During the same period the deposits increased \$2,613,000,000, or about 45 per cent. Investments increased \$383,000,000, or about 60 per cent."

## INFLATION IN BONDS ISSUED BY PUBLIC BODIES.

Criticism, or even a proper understanding of the situation calls for discrimination between the classes into which bonds are

divided. First are those of public bodies; the government, states, counties, cities and sometimes villages. Here a frightful inflation is going on. An old-fashioned public aversion to debt still holds the nation and, to some extent, the states in check; though many of the latter evade it by marketing certificates of indebtedness which differ from bonds only in the shorter time they have to run and the inferior weight of the sanction behind them. The total national debts of Europe rose from about eight billion dollars in the period 1845-48 to nearly thirty billion dollars in 1905-07. With the exception of a slight rise in 1899, made good the following year, the total debt of the United States, less cash in treasury, was greater on the first of last May than it had been for 25 years. In a study of credit made some time ago, I showed that the net ordinary expenses of the United States government had increased 1.4 per cent. between 1870 and 1890, and 121.4 per cent. between 1890 and 1908; while between 1890 and 1909 the expenditures of the 30 states from which reliable reports could be obtained had increased 201.6 per cent.

Most of our cities are mad spenders; intent only on securing an increased margin for bond issues by raising the assessed valuation. Not a few of them are meeting part of their current expenditures by issuing bonds; while refunding, instead of levying taxes to pay at maturity, has become the almost invariable rule. Several large cities whose credit has always stood high have offered bonds within the last few months without finding takers, even at an increased interest rate. This collapse of the market is due not only to a relative scarcity of investment capital at the time, but also to an underlying consciousness on the part of the public that the danger line has been reached. A state, county or city has no income or resources aside from taxation. Public buildings, public improvements, school houses and the apparatus of fire departments could not be sold without dissolving the community itself. They are only imaginary assets. The issue of bonds in excessive volume has, therefore, compelled the buyer to consider a possible inability of the people to pay. That point will presently be reached unless we sharply correct the prevailing policy.

In the five years between 1907 and 1912 the sales of municipal bonds in the United States nearly doubled. According to a summary made this year by the *Commercial and Financial Chronicle*, the average sales for the period immediately preceding 1904 were about \$150,000,000 a year. In 1911 they were \$396,859,000, and in the dull year 1912 they were \$386,551,000. This is an enormous increase for the market to digest. But it is far from telling the whole story. This amount represents only our own actual municipal bonds sales within the territorial limits of the United States.

It is fairly certain that our market cannot absorb such a flood without a perceptible increase in the interest rate and some financial derangement in the conduct of ordinary business. Thus the unchecked rage for borrowing affects not only those who issue and those who sell securities, making it more difficult to place bonds, but also general business operations, by lessening the supply of available free capital and increasing the price at which it can be had.

## INDUSTRIAL BONDS.

The situation with regard to bonds generally spoken of as "industrials" is worse. The field is so large and so diverse as to defy statistical tabulation. Hundreds of millions of bonds have been issued to promote consolidations, these securities being part of the purchase price of the smaller concerns to be united in one big corporation. Other hundreds

\*Abstract of address at the annual banquet of the Investment Bankers' Association of America, Chicago, October 30, 1913.



of millions have been issued against property still to be developed, such as mines, timber lands, irrigated lands and even ordinary real estate, where many separate holdings are combined in the hands of an active selling or developing concern. These are of varying degrees of soundness; from the bond with property behind it that would fetch face value at a forced sale at any time, to more speculative pledges of a future realization or increment that is little better than a guess. Finally, there is the enormous mass, recorded only locally and beyond any reliable estimate in amount of bonds that are not, in view of the flimsy or insufficient security behind them, entitled to be called bonds at all.

In days of soberer financing, an industrial concern was capitalized at somewhere near the amount of cash actually put into the business. With the advent of the large corporation, capital stocks began to grow by multiples of 5, 10, 100. A company could scarcely respect itself if it had less than a million dollars of capital stock; while from five to a hundred millions became not uncommon. Now the market for stock shares is always limited. The supply increased so fast, the underlying values became so attenuated or doubtful, that some additional assurance was needed to bring in the ready money. Here began the deterioration in the significance of the word "bond." Finding that bonds would sell where stocks would not, the promoter substituted the latter for the former. A concern that might reasonably have carried a total capitalization of \$500,000 bonded itself for that amount, and issued half a million or a million dollars of stock in addition. Little local manufacturing or commercial corporations bonded themselves for the limit; the bond in these cases, of course, being nothing but a share of stock, and having no sounder value behind it. The old definition of a bond no longer fits.

In fixing capital stock, a corporation may, to some extent, capitalize its good will. It is not always illegitimate or at all uncommon for a business concern to capitalize its actual profits for a year or a period of years past, sometimes even to capitalize future profits based on percentages of actual past growth, and issue stock to correspond. Except where a community is young, growing rapidly and has a future assured by its possession of great natural resources, this is dangerous financing. But if this capitalization consists of stocks only, and the process is without misrepresentation of facts, the effect is not so bad. The investor knows what he is getting, and takes his chance of a loss for his chance of a profit. The investment market is seldom demoralized in this way. Any disappointment in outcome is part of the necessary percentage of failures on which all business growth is built. But when exactly the same representations are made and the same security is offered for a so-called "bond" issue, the circumstances are materially altered. The old meaning of the word is destroyed. The market for legitimate bonds is impaired. Credit is affected by this tampering with one of its main supports, and the results are disastrous to the community as well as to the investor.

Formerly, and always in any properly financed undertaking, the limit of a bond issue is the total cash value of tangible property in possession; not its value for the uses to which it is being or is to be put, but its value as an asset for immediate conversion by forced sale at any time into cash. Under this rule the investor might rest secure. The worst that could happen to him would be to have to take over this property, in case of a receivership, wind up the business and get back his money. About all that he could lose would be the interest on his investment for the unrealized term of the life of his bond. Now it is altogether different. Not only wild-cat concerns, which are outside the range of this discussion, but companies of real merit and solvency, conducted by men who would scorn to do an act commonly recognized as dishonorable, do not hesitate to bond their businesses for very much more than could be obtained from either a forced sale or a careful liquidation. Plant is set

down at its cost or its estimated value in use, and not its selling price as real estate and second-hand machinery if affairs had to be wound up. And in addition, present or prospective profits or both, and sometimes mere good will, are capitalized. The security behind the bond has deteriorated. Its value is diminished. Capital takes alarm. Loans must be made at a higher rate and are harder to place. Instead of a man's word being as good as his bond, his bond has become no better than his word. Securities of that name which actually deserve it, by being worthy of their lineage and true to the traditions of their past, must jostle their way to market through a mob of tatterdemalions with scarcely a rag of respectability to cover their poverty and deceit.

#### RAILWAY BONDS.

Without undue preference for the interest to which most of my active life has been given, I think I may say that the railroad bonds of this country as a rule have remained faithful to their trust. For one thing, it is practically impossible to place an over-issue of railway bonds. If a manufacturing or commercial concern liquidates, its property has only current real estate value unless some successor wishes to carry on the same or a similar business. If an industrial enterprise is wrecked by competition that it cannot meet, by a shift in the market for raw materials, by a cessation of demand owing to changed conditions or new inventions, its bonds may fall to a few cents on the dollar; because the intangible values behind them are reduced to nothing, and the tangible can no longer be turned to profitable use. A railroad is differently situated. Its business cannot be discontinued. While it may and does suffer from unjust legislative and other assaults that add to its expenses and subtract from its revenues, it enjoys as a compensation security through the courts against actual confiscation. The road and its belongings will always remain there. They can always be operated. They must be operated by somebody. Therefore the security cannot altogether vanish; and the experience has shown that it will eventually bring, under wise management, some return in the most desperate cases.

So far as the old, established properties, with an unbroken record for payment of interest and dividends, are concerned, there is no security that can compare with them for safety of the principal and certainty of the interest payment. The United States government itself has been compelled to suspend specie payments; but the best railway systems of the country went through the stress that drove it to the wall without disappointing investors in them of one dollar when it was due or expected. There never was a bond issued through the centuries since the word first came into use which better deserved to bear the title than the first-class railway bonds that are the favorite investment today of the great life, fire and accident insurance companies, of savings banks, of all who make it their first condition that a security shall have full value behind it, pay at maturity, and be readily convertible into cash with the least shrinkage, even in time of public panic and financial demoralization.

Limitations by law on increase of capitalization are of recent origin. The managements of our railways have, for the most part, financed them voluntarily, so far as bond issues at least are concerned, moderately and wisely. The amount of railway capital outstanding in 1911 was, by official report, a little over \$19,000,000,000. Of this, \$10,738,000,000 was funded debt, \$7,825,000,000 of that amount being bonds. There is no present means of estimating the total money value of railroad property. We do know that it represents the greatest property interest in the country next to the land on which we live, and its improvements. It is so far in excess of capitalization that the margin of safety is plainly in view. It is so much farther from the total of the railway bonded debt that the most careful administrator of a trust never guarded it more completely against possible depreciation.

I showed six years ago that the actual growth of the transportation business called for an immediate investment of at least one billion dollars a year for five years, to catch up with traffic demands. The event proved that forecast under instead of above

the mark. The need grows continually with the increase in population and the development of the country. The money obtained by the sale of securities is put into construction and equipment. So we need not be surprised to learn, according to an estimate made by the *New York Times*, that while, in the year ending October 1, 1912, the railways issued stocks and bonds to a total of \$23,821,000 less than the year preceding, the industrial concerns issued \$362,000,000 more. The remaining class of bonds, those of public utilities, require no separate discussion. Water bonds in most cases stand on the same footing as those of the municipality; gas and electric light bonds are simply a special form of industrials; while street railway bonds resemble those of the steam railways, except that generally a mere franchise instead of an ownership of property is the main guarantee behind them. The creation of public utilities commissions in various states tends to consolidate or standardize all these, so far as their sanction and security are concerned, into a special class of state-approved but not state-guaranteed security.

This survey and analysis should explain whatever may seem mysterious or discouraging in the recent course of the bond market. In spite of the care with which men who understand and respect the limitations of credit attempt to guard and restrict bond issues, the grand total mounts so fast and the security is so progressively impaired that the investor hesitates. Those who are desperate for capital bid higher. The rate of interest rises. So does the risk. And these results, unhappy for the borrower, unhappy for the lender, discouraging and dangerous for the community, will continue until the country reconsiders and amends its ways. The two noticeable features of the general bond situation are the extraordinary conservation in the increase of the railway bonded debt and the extraordinary recklessness of public authorities and the managements of industrial enterprises, taken as a whole, in forcing out every dollar of bonds that anybody will take, until they must finally be advertised as summer sales and peddled out over the bargain counter. Less spending for purposes that can wait; less borrowing on any terms; and a clear distinction between the different classes of security and instruments of credit, so that each shall make its own appeal and cherish its own value, are the only conditions upon which improvement can be hoped. The investment market cannot know a prosperous activity, except by feverish starts to be followed by still more pronounced reactions, until the immutable laws of credit have been generally recognized and respected.

#### SUMMARY OF PRESENT CONDITIONS.

There is plenty of capital in the country. The extent and productivity of our soil, the enterprise of our business men, the sagacity of capital and the industry of labor are continuing that marvelous accumulation of resources which constitutes the aggregate of the nation's wealth. The rate of interest is low for call loans, except in temporary crises. The man with money is content with a small return if he is sure of getting it back the instant a cloud rises in the sky. The reserves of the New York banks show an ample store. But long time loans are hard to place at rates from one-third to one-half higher than they were even three or four years ago. "The simple truth," says a recent financial criticism, "is, the country today is suffering as perhaps never before except in times of actual panic, from a loss of confidence. The money market is abundantly supplied with funds, but there is timidity and fear, so that no one is willing to let his funds go out of reach." There could be no completer illustration of the essentials of credit. The investor is not sure today of either the ability or the intention of the soliciting borrower to pay at maturity. The country is waterlogged with bonds. Confidence cannot be restored until the name "bond" has won back something of its old standard. And that cannot happen until issues are limited by moderation, conformed to the value of the security and confined to the margin of safety and the form of credit for which the bond was originally designed.

A new situation confronts the country, as well as the dealers in investment securities and the men who must find new capital wherewith to satisfy legitimate business needs. Formerly 3½ per cent. in some cases, and at most 4, was regarded a satis-

factory return on a gilt-edged bond. Today the best issues are much higher. Some first-class properties have paid 6 per cent. for short-time loans. This rise, computed on the face of the outstanding securities of the country, represents a tremendous annual tax. It is reflected, of course, not only in the higher cost of living but in a decline of bond prices. This ranges, for high-grade paper, from 4 to 15 points, and in particular cases more. Many financial experts look for a remedy only "through a decline of prices until the interest yield on the money invested in the old issues approximates the increase from the newer bonds, which pay a higher rate of interest." This, of course, is the natural way of working off a debauch, by the operation of natural laws. But it entails great hardship on millions of worthy investors, on savings banks, on those least deserving to suffer. And since, in the main, the situation was not created by observing economic law, but by its violation, it would seem not unreasonable to seek relief by curbing those qualities which have impaired credit, retarded investment and demoralized legitimate business by an over-issue of under-secured bonds, both corporate and public.

After all has been said, the main explanation of prevailing conditions in the bond market runs back to the old law of demand and supply. There has been too much spending and borrowing. The individual, the corporation, the municipality is no longer willing to pay as it goes. The future is mortgaged until the interest charge alone absorbs more current revenue than can be spared. This is the standing danger, the crowning abuse of credit, from which no age has been free. It has been the cause of every act of currency inflation, always aggravating the evil. Inflation by bond issues in excess is just as dangerous in practice, produces the same effects and leads to the same end. Correct this, and the troubles of the market will be relieved; since credit always adjusts itself automatically to the public need when freed from artificial stimulation or compulsion. Let the present abuse of credit continue, and an abyss of possible suffering and financial distress opens before us. This need not happen. It will not happen if the wiser counsel and the conservative view re-assert themselves.

## EMPLOYEES OPPOSE CHICAGO ELECTRIFICATION.

Employees of the Chicago railways are taking a lively interest in opposing the ordinance now pending in the Chicago city council which would require the operation of trains within the city after July 1, 1915, "by other power than that of steam or in a manner that will not produce smoke or any noxious gases that injuriously affect the public health, comfort or convenience."

After the ordinance had been recommended for passage by the committee on railway terminals, representatives of the employees made a fight against it in the city council, and it was referred back to the committee to give the employees a hearing. The railway brotherhoods have organized the Chicago Steam Railroads' Employees' Safety Association, and a committee representing this association appeared before the council committee on October 22, to ask that their hearing be postponed for two weeks to give them time to present data regarding the dangers of electrical operation to the employees. The committee voted to hold the hearing on November 3, after Alderman Long, who introduced the ordinance, had accused the employees of being "sent in as cats-paws for the corporations to obtain further delay." After the committee had declared that the men had an interest in opposition to electrification independent of the railway companies Alderman Long insisted that the ordinance does not require nor contemplate electrification, but is intended simply to compel the roads to become more active in developing smoke preventing devices.

The employees have set forth their argument in a pamphlet addressed to the business men of Chicago entitled "Elec-

trification of the Chicago Railway Terminals from an Employee's Standpoint."

The pamphlet declares that while the ordinance does not mention the word electrification, "this is a pure subterfuge, as it is well known that there has not been invented any other power except steam, that has proved at all practicable for railway operation other than electricity. Steam railroad employees are opposed to electrification at the present time primarily from a safety point of view, because if electrification is forced upon the railroads either the third rail or overhead trolley would have to be used, with their well-understood dangers to life and limb, adding many new dangers to an already exceedingly hazardous occupation. Under the present conditions, as they exist in Chicago, either the overhead trolley or the third rail system would be a constant menace to the lives and limbs of employees in all departments."

It is also asserted that if compelled to electrify the roads will naturally seek to remove as many as possible of their operations outside of the city, so that road crews will leave from outside terminals and that the yards and roundhouses will, of course, have to be located at such terminals, thus compelling a large proportion of the men to give up their homes in the city and move outside. On the ground that there are some 48,000 railroad employees in the city who would be affected by such a condition, representing 192,000, when their families are taken into consideration, and spending a payroll of approximately \$4,000,000 a month, the business men are asked to oppose electrification in order to avoid losing some of their best customers. Other arguments are that electrification would reduce wages, or force out of employment many who have been trained in steam service, but who are too old to adapt themselves to new conditions, and would cause many to lose their fraternal insurance on account of the increased hazard. It is also declared that doing away with the locomotive smoke would have but a small effect on the general smoke nuisance, and that even if the railways make as much as 42 per cent. of the smoke, as estimated by a former city smoke inspector, the larger percentage of smoke and dirt from other sources could be eliminated at a fraction of the cost of electrification. Improvements which the roads have already made by introducing smoke consumers and using a better grade of fuel, are cited, with a statement of the city smoke inspector that the locomotive smoke density was reduced from 23 per cent. in 1910 to 7 per cent. in 1912.

The difference in conditions in Chicago, with its network of yards and switching tracks, and in New York, where comparatively simple passenger terminals have been electrified, are cited to show that electrification would be impracticable in Chicago under present conditions. The statement closes with the following: "Do the business men of Chicago want to force the railroads into a backward step that will increase the dangers to their employees? We believe in progress, we are not opposed to modern developments. But we also believe in 'safety first' and the conservation of humanity. We also believe that any legislation to increase the dangers of our occupation, and that will drive us as workmen and citizens out of our homes that we have worked years to obtain, into open territory where we shall have to build up new homes, schools and churches, is a poor progressive step and the rankest kind of class legislation. Do you want to lose our patronage? Are 48,000 picked workers, representing a payroll of \$4,000,000 a month, worth keeping as citizens of Chicago? If you think they are, if you believe in keeping the railroad accident roll down to a minimum, you will oppose the electrification of the Chicago terminals until such time as it can be done without increasing the dangers of an already hazardous occupation. If the facts stated above appeal to you get busy with your alderman, voice your sentiments among your associates, take the question up in your business organization."

## NEW MISSISSIPPI RIVER BRIDGE AT MEMPHIS.

The Arkansas & Memphis Railway Bridge & Terminal Company was organized last spring for the purpose of building and maintaining a double track railway and highway bridge over the Mississippi river at Memphis, Tenn., to provide an entrance to the city from the west for the Chicago, Rock Island & Pacific; St. Louis, Iron Mountain & Southern, and the St. Louis Southwestern. These lines had previously used the single track bridge of the St. Louis & San Francisco, but the capacity of this structure was not great enough to handle the increasing business of all of these roads. The stock of the new company is owned in equal proportions by the three interested roads. The preliminary plans for the new structure have been completed and the work on the substructure has been begun. The first caisson was launched on October 14.

The new bridge will be located 200 ft. up-stream from the Frisco bridge and parallel to it. The main channel spans will

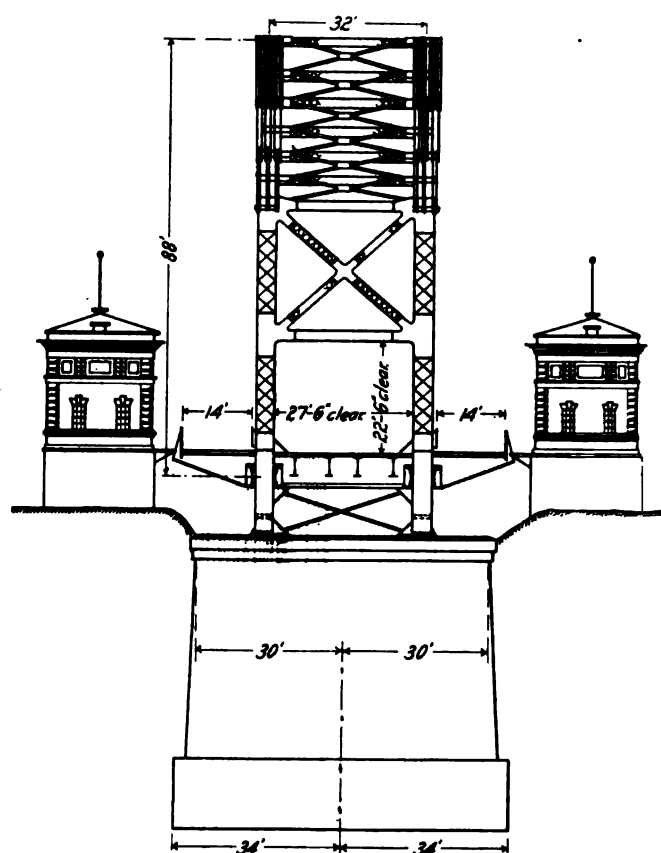

End Elevation of New Memphis Bridge.

have the same opening as the main channel spans of the old bridge, although pier 4 has been moved 17 ft. toward the river in order to make the suspended spans shorter. While the suspended spans in the old bridge were 451 ft. 8 in. long, those in the new bridge will be only 417 ft. 9 $\frac{3}{4}$  in. long. The structure has an overall length of 2,548 ft. 10 $\frac{5}{8}$  in., and consists of the following spans: One deck span, 345 ft., one semi-suspended span, 417 ft. 9 $\frac{3}{4}$  in.; one cantilever arm, 186 ft. 3 $\frac{3}{4}$  in.; one fixed span, 621 ft.; one cantilever arm, 186 ft. 3 $\frac{3}{4}$  in.; one suspended span, 417 ft. 9 $\frac{3}{4}$  in.; one cantilever arm, 186 ft. 3 $\frac{3}{4}$  in., and one anchor arm, 186 ft. 3 $\frac{3}{4}$  in. The trusses will be spaced 32 ft. center to center, giving a clear width between trusses of 27 ft. 6 in. The double track railway line will be carried between these trusses, the tracks being spaced 13 ft. center to center. Two 14 ft. roadways will be carried on brackets outside of the trusses. The maximum depth of the trusses is 88 ft. The load-

ing assumed in the calculations is as follows: For trusses: Live load, 4,000 lbs. per ft., and 40,000 lbs. concentration on each track, also 500 lbs. per lineal ft. on each roadway, except in the case of the suspended span, where 600 lbs. per lineal ft. was used. Unit stresses have been taken conservatively, so that even with a loading on each track corresponding to E-70, no member in the bridge will be stressed over two-thirds of the elastic limit: Track floor: Two engines, 177½ tons on each track (Cooper's E-50): Roadway floor; 17½ ton road roller and 100 lbs. per sq. ft.: Windloads; loaded structure; 30 lbs. per sq. ft. on train and floor as seen in elevation, and in addition, area of truss members for two trusses. Unloaded structure; 50 lbs. per sq. ft. of exposed area of members for two trusses. Two designs are now being prepared, one, that of eye-bars in the continuous structure made of alloy of steel of an elastic limit of 48,000 to 50,000 lbs., and the remainder of the structure of carbon steel; and one where all truss members except those in the anchor arm will be of alloy steel.

To comply with the requirements of navigation on the river, the clear height above the channel is made the same as in the present bridge. This makes the two center piers about 147 ft. high. The elevation of the water in the river is subject to a variation of over 45 ft. The piers will be founded on pneumatic caissons and will be of concrete with a granite facing. The granite will be secured from Stone Mountain, Ga. The high piers have an overall dimension on top of 16 ft. 6 in. x 56 ft. 6 in., and a dimension under the coping of 14 ft x 54 ft. The shaft of the pier is battered ½ in. per foot, and is carried on two 3-ft. footing courses over the caisson. The caissons are

**DEMANDS OF THE WESTERN ENGINEMEN.**

The demands of the western engine-men were served upon the Western Association of Railroads on October 10, by the chiefs of the two engine-men's organizations. The following are the changes demanded by the employees:

**Article I.—Basis of a Day's Work.**

**Passenger Service.**—One hundred miles or less, five hours or less, will constitute a day's work in all classes of passenger service. All mileage in excess of 100 miles shall be paid for pro rata.

**All Other Service Except Switching.**—One hundred miles or less, 10 hours or less, will constitute a day's work in all classes of service except passenger and switching service. All mileage in excess of 100 miles shall be paid for pro rata. Ten miles' run will be the equivalent of one hour's service performed, or vice versa.

Overtime in passenger service will be computed and paid for on a basis of 20 miles per hour, at rate for each class of engine used.

Overtime in all other service except passenger and switching service will be computed on a basis of 10 miles per hour, and paid for at the rate of 15 miles per hour, at rate for each class of engine used.

All overtime will be computed on the minute basis.

**Article II.—Rates of Pay.**

The rate in passenger service on locomotives other than the Mallet type weighing less than:

	Engine-men.	Fire-men.
80,000 lbs. on drivers shall be.....	\$4.50	\$2.90
80,000 lbs. and less than 100,000 lbs. on drivers.....	4.60	3.00
100,000 lbs. and less than 140,000 lbs. on drivers.....	4.80	3.15
140,000 lbs. and less than 170,000 lbs. on drivers.....	5.00	3.25
170,000 lbs. and less than 200,000 lbs. on drivers.....	5.15	3.40
200,000 lbs. and less than 225,000 lbs. on drivers.....	5.35	3.50
225,000 lbs. and less than 250,000 lbs. on drivers.....	5.50	3.65
250,000 lbs. and over on drivers.....	5.60	3.75

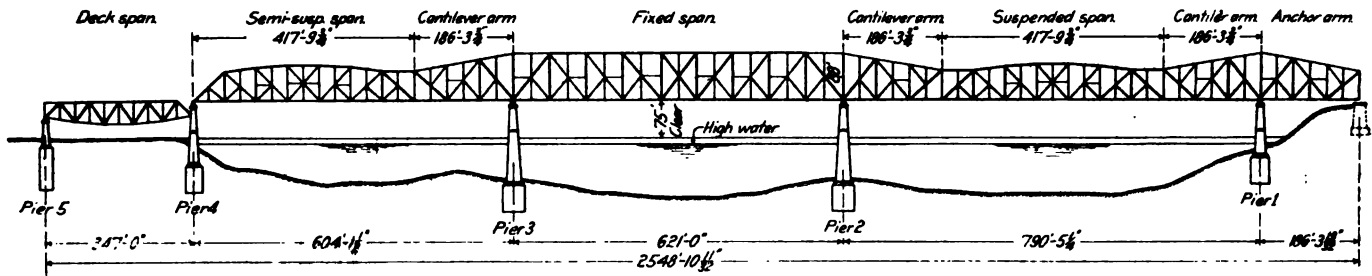

**Elevation of New Mississippi Bridge at Memphis.**

90 ft. x 42 ft., and about 50 ft. high. It is expected to land the bottom of the caissons at elevation 84.25. The piers will be sunk through a very stiff clay. The assumptions made in the design of the substructure were based on the very complete data available from the experience in building the former bridge and it was only necessary to take a comparatively few test borings to check these assumptions.

The substructure is being built by the Union Bridge & Construction Company of Kansas City on a percentage basis. The contract for the superstructure will not be let until late in the winter or early next spring. The designs were prepared under the direction of Ralph Modjeski, civil engineer, Chicago.

**STATE RAILWAY MILEAGE IN QUEENSLAND.**—The total length of railways included in the Queensland state system on June 30, 1912, was 4,266 miles, inclusive of the Etheridge Railway (143 miles), which was built by a private company but is operated by the state railway department. The lines are 3 ft. 6 in. gage.

**PRIVATE-CAR TROUBLE IN ENGLAND.**—After the end of this year no wagons (freight cars) will be allowed on the railways in Great Britain which are not fitted with spring buffers. This is in accordance with a notice issued by the Clearing House seven years ago; but it is said that the proprietors of coal mines have from 8,000 to 12,000 wagons still in use which have only "dead" buffers—those not fitted with springs. What can be done with these cars after December 31 is a question which now gives rise to some anxiety.

In all classes of service except passenger and switching service on locomotives other than Mallet type weighing less than:

	Engine-men.	Fire-men.
80,000 lbs. on drivers shall be.....	\$5.00	\$3.25
80,000 lbs. and less than 100,000 lbs. on drivers.....	5.20	3.40
100,000 lbs. and less than 140,000 lbs. on drivers.....	5.40	3.50
140,000 lbs. and less than 170,000 lbs. on drivers.....	5.60	3.65
170,000 lbs. and less than 200,000 lbs. on drivers.....	5.80	3.75
200,000 lbs. and less than 225,000 lbs. on drivers.....	6.10	4.00
225,000 lbs. and less than 250,000 lbs. on drivers.....	6.40	4.25
250,000 lbs. and over on drivers.....	6.70	4.50

Mallet type engines, all classes of service, except switching service, weighing less than:

	Engine-men.	Fire-men.
250,000 lbs. on drivers.....	\$7.50	\$4.90
250,000 lbs. and less than 300,000 lbs. on drivers.....	7.75	5.10
300,000 lbs. and less than 400,000 lbs. on drivers.....	8.00	5.25
400,000 lbs. and over on drivers.....	8.25	5.50

Engineers and firemen on locomotives in pusher and helper service, mine runs, work, wreck, belt line and transfer service, and all other unclassified service, will be paid through freight rate according to the class of engine.

On all divisions where grade is 1.8 per cent. or over, an increase of 10 per cent. over valley rates will be paid.

On roads where narrow gage locomotives are in service, a 5 per cent. increase over present rates in effect shall be granted.

Wherever electric, multiple unit, gasoline or other service is installed as a substitute for steam, or is now in operation on any railroad parties to this agreement or on any of the tracks operated or controlled by any of them as part of their system, the locomotive engineers and firemen shall have the right to the position of motorman and helper, respectively. The term "helper" will be understood to mean the second man employed on electric locomotives or other power.

Seniority rights to be interchangeable. Steam rules, hours of service and mileage to apply with the following rates of pay:

	Motorman.	Helper.
Passenger service—		
20,000 lbs. tractive power and less.....	\$4.50	\$3.35
Over 20,000 lbs. tractive power and less than 25,000 lbs.....	4.60	3.35

Passenger Service—		Motor-	Helper.
Over 25,000 lbs. tractive power and less than 30,000 lbs.....	4.70	3.35	
Over 30,000 lbs. tractive power and less than 35,000 lbs.....	4.80	3.35	
Over 35,000 lbs. tractive power and less than 40,000 lbs.....	4.90	3.35	
Over 40,000 lbs. tractive power and less than 45,000 lbs.....	5.00	3.35	
Over 45,000 lbs. tractive power and less than 50,000 lbs.....	5.15	3.35	
Over 50,000 lbs. tractive power and less than 55,000 lbs.....	5.35	3.35	
Over 55,000 lbs. tractive power and less than 60,000 lbs.....	5.50	3.35	
Over 60,000 lbs. tractive power and over.....	5.60	3.35	

All Other Service Except Passenger and Switching—		Motor-	Helper.
20,000 lbs. tractive power and less.....	\$5.00	\$3.75	
Over 20,000 lbs. tractive power and less than 25,000 lbs.....	5.20	3.75	
Over 25,000 lbs. tractive power and less than 30,000 lbs.....	5.30	3.75	
Over 30,000 lbs. tractive power and less than 35,000 lbs.....	5.40	3.75	
Over 35,000 lbs. tractive power and less than 40,000 lbs.....	5.60	3.75	
Over 40,000 lbs. tractive power and less than 45,000 lbs.....	5.80	3.75	
Over 45,000 lbs. tractive power and less than 50,000 lbs.....	6.00	3.75	
Over 50,000 lbs. tractive power and less than 55,000 lbs.....	6.20	3.75	
Over 55,000 lbs. tractive power and less than 60,000 lbs.....	6.40	3.75	
Over 60,000 lbs. tractive power and less than 65,000 lbs.....	6.60	3.75	
Over 65,000 lbs. tractive power and less than 70,000 lbs.....	6.80	3.75	
Over 70,000 lbs. tractive power and over.....	7.00	3.75	

Switching Service—		Motor-	Helper.
20,000 lbs. tractive power and less.....	\$4.75	\$3.10	
Over 20,000 lbs. tractive power and less than 40,000 lbs.....	5.00	3.10	
Over 40,000 lbs. tractive power and less than 60,000 lbs.....	5.50	3.10	
Over 60,000 lbs. tractive power.....	6.00	3.10	

Article III.—Local or Way Freight Service.

Local trains are way freight or mixed trains whose work is the loading or unloading of freight or doing station switching en route.

Engineers and firemen on such trains will be paid 10 per cent. increase over through freight rates.

Through or irregular freight trains doing work such as loading or unloading freight, stock or company material, switching at stations, spurs, mines, mills, or required to pick up or set out cars, unless cars to be picked up are first out, or cars to be set out are switched together at terminals, or doing any other similar work, shall be paid for same at overtime rates in addition to time or mileage made on the trip.

Article IV.—Switching Service.

Rates of Pay—	Engi-	Fire-
	neers.	men.
Engines weighing less than 140,000 lbs. on drivers.....	\$4.75	\$3.10
Engines weighing 140,000 lbs. and over on drivers.....	5.00	3.25
Mallet type engines.....	6.00	4.00

Engineers and firemen required to begin service other than between the hours of 6 a. m. and 8 a. m. will be paid 2 cents per hour, in addition to above rate.

Ten hours or less will constitute a day's work in switching service. Time to be computed continuously, all over 10 hours to be computed and paid for at rate of time and one-half. All overtime to be computed on minute basis.

Switch engineers and firemen will not be required to work longer than 6 consecutive hours without being allowed 30 minutes undisturbed for meals.

When road engines are used in yard service, road rates will apply.

Article V.—Preparatory Time.

Engineers and firemen in all classes of service will be allowed 30 minutes as preparatory time in addition to all other time or mileage made on the trip or day, at the pro rata rate corresponding with class of locomotive and service; provided, that on lines of railroad where rules or schedules require them to be on duty more than 30 minutes before time ordered to leave roundhouse or other point, they will be allowed one hour's time, and when required to be on duty more than one hour, actual time will be allowed. Preparatory time will be the time engineers and firemen are required to be on their locomotives, prior to time ordered to leave roundhouse or other point.

Article VI.—Terminal Delay.

Passenger Service.—Initial terminal delay for engineers and firemen in passenger service shall begin at the time they are called to leave roundhouse or other point and shall end upon departure of trains from passenger depot.

Final terminal delay for engineers and firemen in passenger service shall begin at the time they arrive at passenger depot, and will end when relieved from duty.

Freight Service.—Initial terminal delay in freight service shall begin at the time engineers and firemen are called to leave roundhouse or other point and shall end when train has passed from yard track or lead to main line, and actually departs from the terminal.

Final terminal delay in freight service shall begin when train arrives at switch leading from main line into yard, and shall end when engineer and firemen are relieved from duty; provided, that if from any cause trains are held out of yard, final terminal delay shall begin.

Engineers and firemen shall be paid on a minute basis for all terminal delay, at the pro rata rate for the class of engine used; this in addition to all time or mileage made on the trip.

Article VII.—Automatic Release and Tie-up.

Engineers and firemen arriving at terminal or end of run are automatically released; when used again, they begin a new day.

Engineers and firemen tied up between their terminals will be paid continuous time; no deductions will be made for time tied up.

Article VIII.—Held Away from Home Terminals.

Engineers and firemen held at other than home terminals (including rest period) will be paid continuous time for all time so held, after the expiration of 15 hours from time relieved from previous duty, at the rate per hour paid for the last service performed; less than one hour not to be paid for.

Article IX.—Deadheading.

Engineers and firemen deadheading on company business shall be paid at the same rate and on the same basis as the engineer and fireman on the train on which deadheading. Rules in individual schedules governing minimum day, and other conditions to apply.

Article X.—Hostlers.

At points where an average of 6 or more locomotives are handled within 12 hours, day or night, hostlers shall be maintained.

Hostling positions shall be filled from the ranks of the firemen, and they shall be paid \$3.35 per day of 10 hours or less; provided, that where hostlers are required to make main line movements, they shall be paid \$4.75 per day of 10 hours or less, overtime in each case to be computed on the minute basis and paid for at the rate of time and one-half.

When such main line or road hostlers are paid the same rate as engineers in switching service, such position shall be filled from the ranks of the engineers.

Hostlers shall be allowed one hour for meals between the hours of 11:30 and 1:30, day or night. Hostlers will be assigned regular meal hour between the hours named or after being on duty five hours. Should hostlers be required to remain on duty after designated meal hour, one hour will be allowed as overtime. No hostler will be required to remain on duty longer than six hours without having one full hour for meals.

Article XI.—Surprise Tests.

That the practice of conducting surprise tests by turning switch lights and placing red lights, or flags, unaccompanied by torpedoes, beside track, or wiring down automatic signals to proceed position, be eliminated.

Article XII.—Assistance for Firemen.

On all locomotives in freight service where but one fireman is employed, and on all locomotives in passenger service, coal will be kept where it can be reached by the firemen from the deck of the locomotive. Coal of the proper size for firing purposes will be placed on all tenders.

Article XIII.—Two Firemen.

On coal burning locomotives weighing 185,000 lbs. or more on drivers, when used in freight service, two firemen will be employed.

Article XIV.—Miscellaneous.

On railroads where firemen are required to clean locomotives, they shall be relieved of such service.

Where engineers and firemen are required to set up wedges, fill grease cups, or clean headlights, they shall be relieved of such service at all points where roundhouse, or shop force, or an engine watchman is employed.

Where engineers and firemen are required to place on or remove tools or supplies from locomotives, fill lubricators, flange oilers, headlights, markers or other lamps, they shall be relieved of such service at all points where roundhouse, shop force, or an engine watchman is employed.

Article XV.—Official Record of Weights on Drivers.

For the purpose of recording weights on drivers, each railroad, parties to this agreement, will permanently post bulletins at all terminals showing accurate service weights of all locomotives.

Article XVI.—Throwing Switches and Flagging.

Engineers and firemen will not be required to throw switches, flag through blocks, or fill water cars.

IMPROVING SWISS TUNNEL ROUTES.—A new line is being built between Frasné, in France, and Vallorbe, on the frontier, including a four mile tunnel, which will shorten the line of approach to the Simplon tunnel by 12 miles, thereby adding a time-saving feature to that important route. The Swiss government has also undertaken the work of finishing the second Simplon tunnel, in order to meet the demands of increasing traffic. The plans of the Simplon originally comprised two single track tunnels, only one of which was finished, however, the gallery of the second being pierced, and serving as an air shaft and for the drainage of water from the first tunnel during construction. The work now to be done consists of enlarging the gallery to the extent of accommodating a single track, thus doubling the traffic facilities and the carrying capacity of the line. A concession has been granted to the Loetschberg for a new line, which will shorten the approach and act as a feeder to the principal route from the French side. This line will cross the Jura mountains by a tunnel nearly five miles long between Moutiers, on the Basel-Delle-Biel line, and Longeau, a station on the Zurich-Olten-Biel line.

### A DIVISION OFFICE BUILDING DESIGNED FOR THE HINE SYSTEM OF ORGANIZATION.

The Arizona Eastern is now constructing a new office building at Phoenix, Ariz., embodying a number of interesting features, as it is designed for use with the Hine system of organization in effect on that line. In the first place, instead of the division offices being located over the station, as is generally the rule, they are located in the division yard adjacent to the roundhouse and classification yard to increase the facilities of supervision over this most important unit of the division. This building and

the first floor. The offices of the yardmaster and roundhouse foreman are located immediately off the entrance hall on the side of the building facing the classification yard, enabling the yardmaster to have a view over this yard. A bulletin board for employees will be posted in the entrance hall and an instruction room for lectures on air brake operation and other subjects is provided on the same floor. Back of this is the division storeroom with an unloading platform on the track side and a counter on the roundhouse side over which materials will be issued for the mechanical department.

The second, or office floor, is surrounded on three sides with

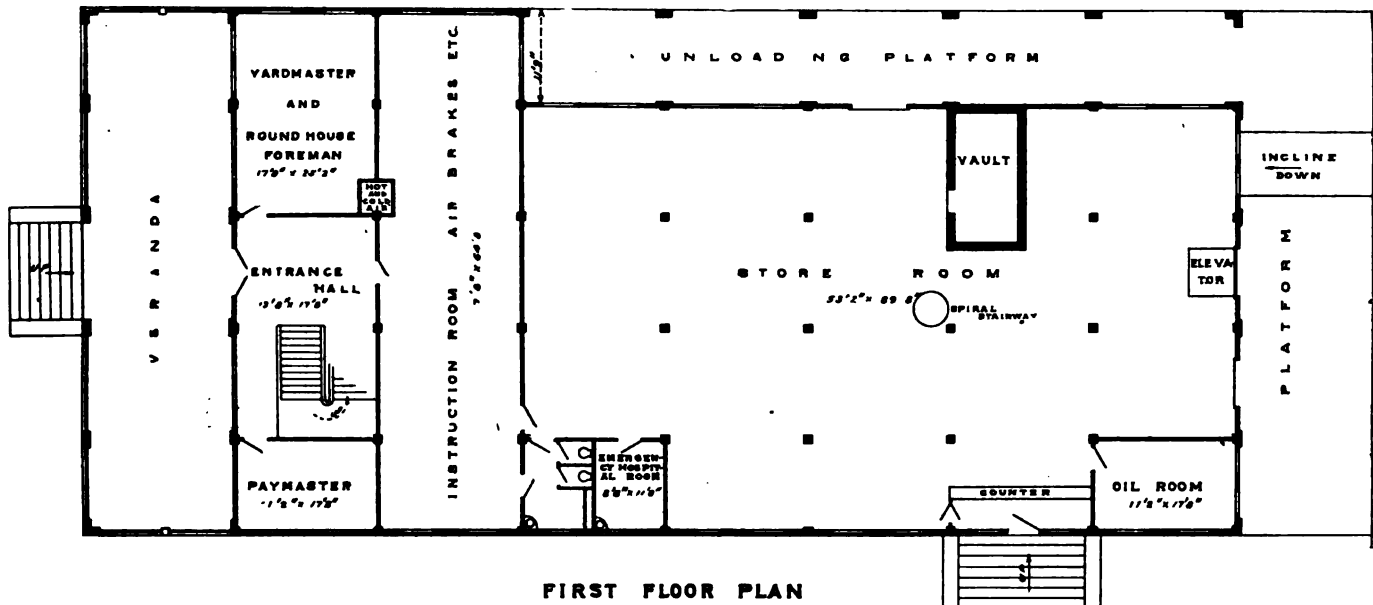

FIRST FLOOR PLAN

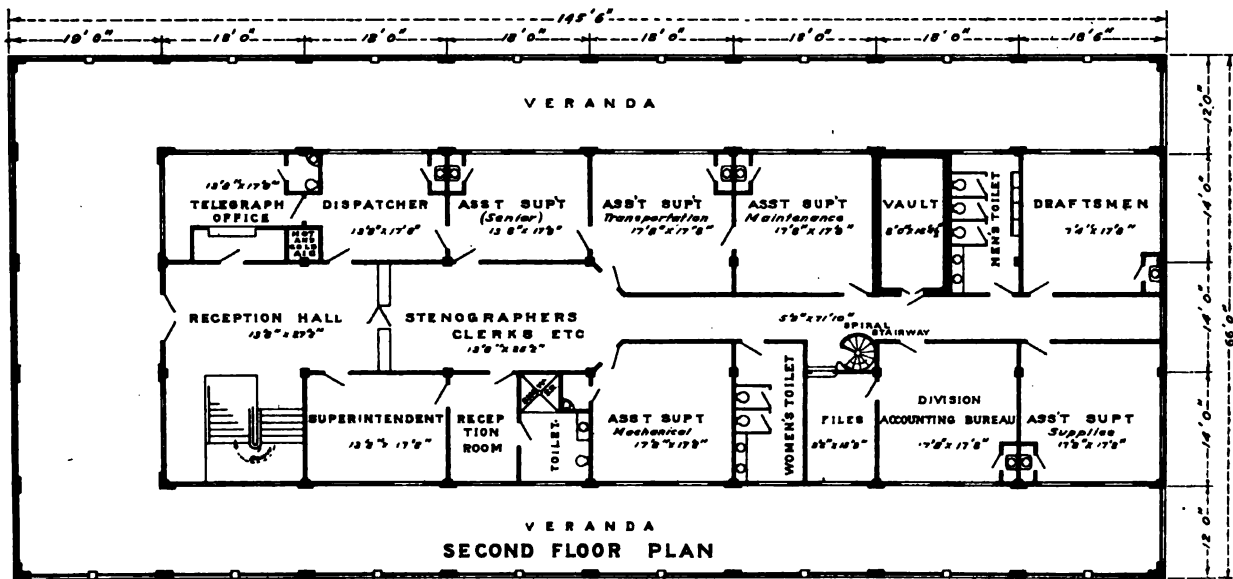

SECOND FLOOR PLAN

Floor Plans of Arizona Eastern Division Office Building.

the tracks now being built from a part of a large future development, the details of which are provided for in the present plan.

The office building is located between the classification yard and the roundhouse. It is 145 ft. 6 in. long by 66 ft. wide, of concrete construction and is two stories high with a basement. It is being built entirely by company forces. The basement will be devoted to the storage of inflammable materials with a special room for oils. A fireproof vault extends continuously through all three floors, the basement portion being utilized for the storage of torpedoes, etc.

Entrance to the building will be gained from the veranda on

a veranda, essential to all office buildings in this climate. Immediately adjoining the reception hall on the side facing the yard are the telegraph and dispatchers' offices where train crews will get their orders, thus bringing them directly in contact with responsible officers who are enabled to inspect the men before they leave on their runs. The senior assistant superintendent and the assistant superintendents in charge of transportation and maintenance, are located on the same side of the building, while the drafting office is located in the rear corner adjacent to the vault which is used in common with the general office for the storing of tracings and office records. On the opposite side of

the building facing the roundhouse are the offices of the superintendent and the assistant superintendent in charge of mechanical matters. The assistant superintendent in charge of supplies (storekeeper) is located in the rear, a spiral stairway connecting this floor with the storeroom proper.

The general ideas for this building were worked out by Major Hine, formerly vice-president and general manager of the Arizona Eastern, as a development of his unit system of operation. The general details of the building proper were prepared under the direction of John D. Isaacs, consulting engineer, Southern Pacific, while the detailed plans were prepared by the local division forces.

### CHARACTERISTICS AND OPERATING FEATURES OF THE GAS-ELECTRIC CAR.\*

By L. C. JOSEPHS, JR.,

Engineering Department, General Electric Company, Schenectady, N. Y.

The first consideration in the design of any self-propelled car is the size of engine required. From experience it has been found that an engine rating of from  $1\frac{1}{2}$  to  $1\frac{3}{4}$  kw. per ton of car is about the proper amount for service in this country for cars which occasionally haul trailers. In Europe where service conditions are easier, and schedule speeds are lower, the engine equipment required is much smaller. In giving this engine rating it should be considered as the continuous rating of the engine without overheating or injury. The maximum rating of the engine for short periods may be as much as 50 per cent. more.

The generator required for a gas-electric car should be about the most flexible machine that can possibly be designed,

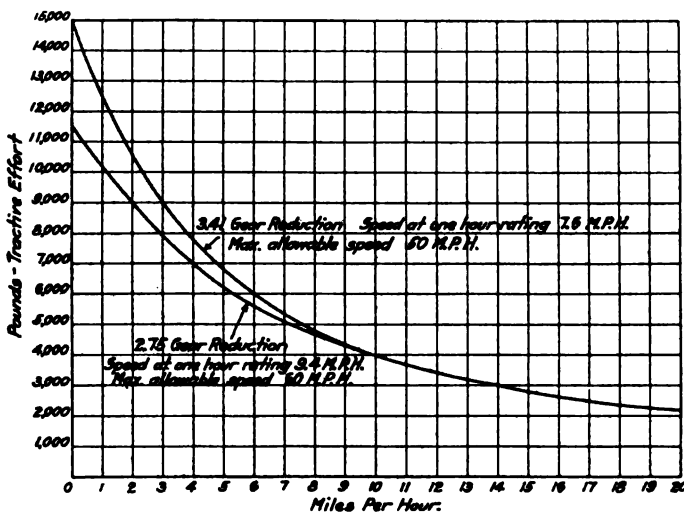

Fig. 1—Effect of Gear Ratios on Speed and Tractive Effort.

and it must be capable of operating under a wide range of speeds from 50 per cent. below rated speed to 25 per cent. above.

The current range of the generator must be from 50 per cent. below to 200 per cent. above its normal rating, and the voltage range must be from 70 per cent. below to 30 per cent. above normal voltage rating. The compounding of the generator should preferably be practically flat, and may be accomplished through the effect of the interpole field. The generator armature must be of the most liberal design. It must have a very high temperature capacity for a short time, although the continuous temperature capacity need not be great.

The proper kilowatt rating of the generator should be about 80 per cent. of the engine rating. This rating, however, has

\*Abstracted from a paper presented at the recent convention of the Association of Railway Electrical Engineers.

very little meaning, as when the generator is operating on high voltage with high core loss, the current is low, and the copper loss is low, and vice versa, when the generator is operating on high current with large copper loss the voltage is low, with correspondingly low core loss.

The motors used on a gas-electric car can be of the standard railway type, thus permitting the use of equipment that has proven its merits by many years of service, and simplifying methods of maintenance and inspection, but as these motors must be operated under conditions of service such as are found on the branch lines of many railroads, they must be of the most rugged construction, and capable of operating for long periods without attention.

The choice of gear ratio and wheel diameter is an important consideration. In general, for cars having 33 in. wheels and motors having an allowable maximum armature speed of 1,800 r. p. m., a gear reduction of about 2.75 is satisfactory. The choice of these various quantities depends of course on the motor used and the kind of service the car is going to operate in. The above combination is one that has been

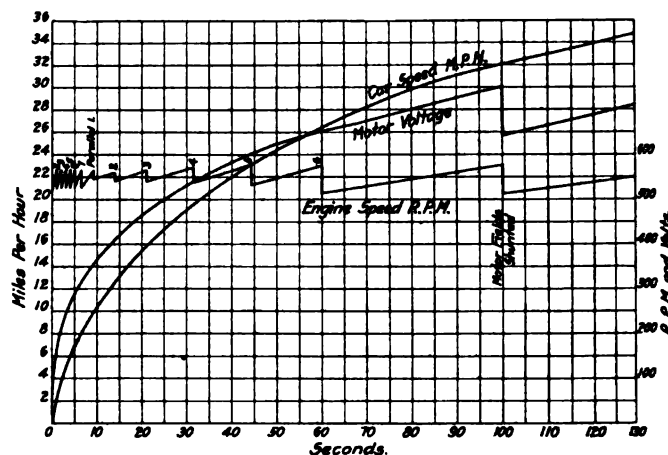

Fig. 2—Acceleration Curve for 60-Ton Car.

found satisfactory for single motor cars in average service where trailers are hauled occasionally. For 100 kw. generator output this combination gives about 12,000 lbs. tractive effort at starting, allows a maximum speed of 60 m. p. h., and a tractive effort of 4,200 lbs. at 9.5 m. p. h. at the rated load of the motors. For gas-electric locomotives and cars operating with trailers at low speeds, the maximum gear reduction obtainable is desirable. This gives slightly more tractive effort at starting, and a much lower speed at the rated load of the motors, but makes very little difference in the general speed-tractive effort relations for the equipment. To indicate how little this difference is, two curves are shown in Fig. 1 giving the speed-tractive effort relations for similar equipments having gear ratios of 2.75 and 3.41 respectively. It will be noted that above 10 m. p. h. the two curves are identical.

The motor rating on a gas-electric car should be about 125 per cent. of the generator rating. This difference is easily accounted for by the different methods of rating the two types of machines. The generator according to custom is rated on a basis of a 50 deg. C. temperature rise while railway motors are usually allowed 75 deg. C. rise.

It is desirable in a gas-electric car to have a variable speed engine on account of the added flexibility of the control. The arrangement of the motor connections may be controlled by means of the ordinary type of drum controller such as is used in trolley cars. The control of the generator shunt field current may be effected by any convenient form of field rheostat. This rheostat should best be operated by the same handle as the main motor controller. Thus, for the series motor connection the generator voltage may be brought by successive steps from its lowest point to full voltage, the

motor voltage being at all times one-half the generator voltage; and for the parallel motor connection the generator voltage may again be brought by successive steps from its lowest point to full voltage with the motor voltage now equal to the generator voltage. In practice it is found for ordinary motor car equipments that about 7 steps of voltage for the series connection of the motors, and 6 steps of voltage for the parallel connection of the motors is the most desirable combination. This gives therefore 13 different points on which the motors may be operated. Moreover, by varying the engine speed the voltage may be made to vary over wide ranges for each notch of the controller. This means a complete range of motor voltage from the lowest point of stability to the point where the generator field is fully saturated. In operating the car in order to obtain smooth acceleration, use is made of both control of the generator field and of the engine speed. This is best shown graphically by the curve in Fig. 2 showing the variation of car speed, engine speed, and voltage during the acceleration of a 60-ton car.

The idea of using a storage battery as an auxiliary on a gas-electric car has been suggested occasionally. A storage battery is primarily constant voltage apparatus and cannot be fitted into the plan of a gas-electric car without the use of relays and other parts to get out of order, unless the plan is so changed as to make the control entirely constant voltage.

PERFORMANCE.

In operating a gas-electric car care should be taken not to crowd the controller to such an extent as to allow wide variations of engine speed from the best operating speed, which is the speed of maximum fuel economy. This is best illustrated by the accompanying table, giving the car speed and tractive effort at various engine speeds on each notch of the controller. It will be noticed from this table that an engine speed of about 550 r. p. m. is the best to use, because this is the engine speed at which the tractive effort and speeds at each control notch are best distributed throughout the range of operation. At speeds lower than 550 r. p. m. several notches become worthless and at speeds higher than 550 r. p. m. the jump from series to parallel notches becomes too great.

In figuring on the service that a gas-electric car can perform there are two important points to determine; first, the schedule speed that can be made, and second, whether the service can be maintained without overheating the equipment.

operating in out of the way points at the far ends of poorly paying branch lines.

Any one who has had experience with a gas engine realizes the truth of the statement that the time to fix a gas engine is before it breaks down and not after. It has been the experience of those supervising motor cars that some large breakdown which perhaps required a day to fix was caused by the neglect of some small adjustment that could have been fixed in less than a minute by any one with a screw driver or small wrench. It is this kind of forehanded maintenance that is particularly necessary on gas electric motor cars, and it is for this reason that the instruction and examination of the operators is most important. So far as the class of labor required to operate motor cars is concerned, it has usually been customary to place on the car the steam engineer who formerly had the same run when it was steam service, and it has been found in general that a man of the caliber of a locomotive engineer is perfectly capable of making a good motor car operator, but it is absolutely necessary that he receive careful instruction, and this instruction should be of a broad nature, placing more emphasis on his understanding the equipment than his being able to answer a larger list of questions. Where things can be explained by means of parallels found in the steam engine it is of advantage to do so, but care should be taken not to stretch the truth to too great an extent so that an engineer will for example compare shunting the motor fields to the hooking up of the reverse lever on a steam locomotive.

The motor car operators should be expected to make all adjustments to their cars and to look over the engine and other equipment at the close of every day's run and make out a work report if they find work that requires attention before the following day's run. It is then usually necessary to have one of the machinists from the roundhouse or repair shop broken in to understand the motor car. This maintainer will have to make all regular running repairs. The tools he will require will be no more than the ordinary hand tools of a skilled machinist. If the work of the operator in inspecting and adjusting his equipment is of the best character the work of the maintainer will amount to little more than putting in an occasional packing blown out, or some labor of equally light nature. If the operator, however, is careless in his methods of inspection, the work of the maintainer will be correspondingly increased.

In order to check the work of the operator and maintainer it is important that a motor car should have an inspection at regular periods, and as a check, it is desirable that this

TABLE OF TRACTIVE EFFORT AND SPEED.

Engine Speed.....	650		600		550		500		400		300		
	Notch	T. E.	Spd.	T. E.	Spd.	T. E.	Spd.	T. E.	Spd.	T. E.	Spd.	T. E.	Spd.
Series 1.....	.....	.....	0	.....	.....	0	.....	.....	.....	.....	.....	.....	.....
2.....	6800	9.5	.....	8350	6.4	11900	2.3	4570	0	.....	.....	.....	.....
3.....	6500	10.4	.....	7650	7.6	9950	4.1	11100	0	.....	.....	.....	.....
4.....	6060	11.4	.....	6850	8.8	8160	6.3	10950	2.8	.....	.....	.....	.....
5.....	5600	12.7	.....	6250	10.5	7100	8.2	8340	5.7	4580	0	.....	.....
6.....	5180	14.3	.....	5740	11.9	6350	9.9	7100	7.7	10000	2.8	.....	.....
7.....	4480	17.1	.....	4850	15.0	5370	12.4	5860	10.3	7330	5.7	10450	1.5
Parallel 1.....	2820	29.3	.....	3540	21.8	5300	12.7	10450	0	.....	.....	.....	.....
2.....	2700	30.8	.....	3260	24.3	4300	16.7	9450	4.2	.....	.....	.....	.....
3.....	2520	33.5	.....	2890	27.6	3500	20.7	4850	13.7	.....	.....	.....	.....
4.....	2320	36.0	.....	2590	30.8	3000	25.7	3550	19.9	10450	0	.....	.....
5.....	2100	40.4	.....	2380	34.6	2640	29.5	3000	24.4	4400	13.4	4580	0
6.....	1770	48.4	.....	1960	42.0	2240	35.8	2430	30.8	3080	20.5	4550	10.2
Shunted 1.....	1730	49.3	.....	1960	41.3	2220	35.0	2480	28.6	3740	15.1	3900	0
Fields 2.....	1450	59.6	.....	1610	51.3	1820	43.2	2000	38.5	2570	23.6	3860	11.6

MAINTENANCE AND INSPECTION.

In a great many ways the equipment used on motor cars is very similar to the train lighting equipment used on passenger cars, and requires very much the same kind of attention. On account of the characteristics of the gas-electric motor car and because it is able to furnish light branch line service at low cost, it is not uncommon to find motor cars

inspection should be made by some other person than the operator or maintainer. The men on a modern railroad who are best equipped to make such an inspection are the electrical inspectors who look after the train lighting equipment. One of these men can be very quickly educated to understand the motor car, will usually take a keen interest in it, and can be sent at regular periods to visit the motor cars in his ter-



ritory and make the inspection of all parts both mechanical and electrical. The report made out by this inspector can be turned in to the main office as a record of the condition of each motor car from time to time.

In the discussion of the paper it was pointed out that cars should be held at their rated capacity rather than constantly taking advantage of the overload possibilities. The maintenance should be carefully watched and repairs made in time to prevent large expenditures on heavy repairs. J. E. Hilton, general motor car inspector of the Frisco, presented some very interesting figures. For the six months ending June 30, 1913, the cost of operation and repairs of seven gas-electric cars on that line averaged 18.5 cents per mile, which included the general overhauling of three cars. Some of these cars are placed in severe service with a 30-ton trailer, and have a very efficient operating record. The lowest average cost per car is 15.1 cents per mile for six months' service, with a total mileage of 30,519 miles. This car hauled a 66,000 lb. trailer during that time.

## THE ECONOMY OF CAPACITY LOADING FROM THE SHIPPER'S POINT OF VIEW.

BY GORDON WILSON,

Assistant Secretary, Universal Portland Cement Company.

Our annual car shortage has become a regular topic every fall, not only for the railroad magazines, but also for the trade papers, and even for the daily press. Just as surely as the morning papers on the fifth of July contain a list of the previous day's killed and wounded, so, about the time the crops begin to ripen, we begin to receive prophecies and discussions of the impending car shortage. Presently, when the famine has become an established fact, we are given the harrowing details of the loss and distress that have been caused thereby. Everyone struggles as best he can through the agonizing period of car shortage, then gives a sigh of relief and settles down comfortably as though there would never be another car shortage in all the history of the world.

There will be car shortages. There will continue to be car shortages unless the freight car equipment of this country should become large enough to handle peak loads regardless of how, when, or where they might occur. A condition of this kind, while comfortable to shippers and consignees, would be uneconomical and wrong, however, because it would mean that for months at a time millions of dollars of this country's capital would be tied up in idle cars and in tracks on which to store them. It is to be hoped that the time will come when our freight carrying equipment will be adequate, if kept in proper repair, properly loaded, intelligently distributed, and handled with proper speed, to take care of the natural movements of merchandise that occur, but in the meantime it is the duty of every good citizen to get the greatest possible efficiency out of the equipment that is available, in order that the evil effects of our car shortages may at least be minimized.

Car shortages strike first and most directly at the shipper. Therefore anything that the shipper can do to increase car efficiency is for his own immediate benefit. The advantages to be gained by getting the highest efficiency go further back, though, than the slight relief which is offered in times of car famine. As a case in point, I would like to quote a little history with which I am familiar. In 1911 the average load per car shipped by the Universal Portland Cement Company was 67,640 lbs., in 1912, 70,300 lbs., and for the first eight months of 1913, 73,606 lbs. These increases of about 3,000 lbs. per car per year may not seem to be very significant, but if we had not increased our average loading in 1912, we would have required 2,132 cars more to take care of the number of barrels of cement that we shipped in that year. Figuring on the same basis, our saving for the first eight months in 1913 is 3,307 cars

as compared with our 1911 record, and 1,758 cars as compared with the improved record that we made in 1912. In other words, through the simple expedient of getting greater efficiency out of the cars that we load, we have been able to release over two thousand cars a year for the use of other shippers, not only without hurting ourselves in any way, but actually to our own advantage.

There is a certain amount of unproductive expense attached to the loading of every car. Each car has to be cleaned and prepared for loading. After a car is loaded it has to be pinched down the track from the loading door and another car spotted in its place. During this time the shipping crew stands idle. The cost of the time of a gang of men for the period required to move out a load and replace it with another empty is well worth consideration. Multiply it by the number of cars that have to be loaded in the course of a month, and it amounts to a figure that is worth while trying to cut. If the amount of product to be shipped in the course of a month can be loaded into a smaller number of cars, the cost of loading, per unit of product, is correspondingly reduced, and incidentally the profit per unit on the material is correspondingly increased.

This is a plea for capacity loading twelve months in the year. If the cars that are shipped in the spring and early summer can be loaded heavier than they have been, the manufacturer will have a smaller proportion of his year's output to ship during the latter months of the year when the cars are not so plentiful. His goods will already be at the market instead of in his warehouse at his factory. The habit of capacity loading will have become established, so that fewer cars will be required to take the product that still remains to be shipped, and if this condition could be made general, there would be more cars available. The customer whose shipments are delayed time after time on account of car shortage will be given larger shipments when he does get them, and these larger shipments to the customer will carry him for longer periods of time between the placing of orders.

A great deal of the underloading of cars is due to habit or thoughtlessness. People who began to order in carload lots when fifteen and twenty ton cars predominated are still placing fifteen and twenty ton orders, although thirty, forty and fifty ton cars have become the standard equipment. On the same principle, we have found that one of the most common causes of lost car efficiency is the habit of thinking in round numbers. A man would order a car of 100, 150, or, maybe, 200 barrels. Cement manufacturers themselves, when shipping capacity loads, were shipping cars of 170, 230, or 280 barrels, in spite of the fact that these same cars, when loaded to the limit of their capacity plus 10 per cent., would carry 173, 231, and 289 barrels, respectively. A great part of the improvement that we have made in the weight of our average carload, as noted above, has been due to the fact that we and our customers have stopped thinking in round numbers—in multiples of ten—and have given a great many cars the exact limit of the load that they can carry. Of course there are cases when full capacity loads cannot be shipped, and there are times when a concern that is endeavoring to do its share towards increasing car efficiency will be suspected of ulterior motives, but in general it has been our experience that the average consignee will readily appreciate the importance of this car efficiency movement, and will gladly render his aid in furtherance of it. One of our salesmen was presenting this subject to a customer who had always ordered his cement in carloads of 150 barrels each. The customer agreed that he was wasting a part of the service of every car that he ordered, but explained that his warehouse would hold only 150 barrels. "All right," said our salesman, "let us load this car to 173 barrels, and when you get your notice of shipment, go out and sell a wagonload to be hauled direct from the car as soon as it gets in." This suggestion solved that dealer's problem, and ever since then his orders have called for cars of 173 barrels.

## NATIONAL ASSOCIATION OF RAILWAY COMMISSIONERS.

The twenty-fifth annual convention of this association was opened in Washington on Tuesday of this week, and Chairman E. E. Clark of the Interstate Commerce Commission welcomed the members to Washington. After a brief reference to the progress of the past dozen years, Mr. Clark said:

We all occupy positions of tremendous responsibilities and are invested with unprecedented authority. Upon our zeal, patriotism, efficiency and judgment, rests largely the commercial welfare of our country.

In this as in other lines of public work, we find extremists on both sides, who, unless their ideas are accepted and followed, exercise to its full extent the American's prerogative of criticism. Their criticism is often founded in lack of knowledge as to facts, and sometimes in a willingness to disregard the rights of others. Such criticism creates misunderstandings and misconceptions, but if we are not broad enough to refrain from being influenced or swerved by it, we are lacking in true capacity and fitness for the positions which we occupy.

The situation that existed when regulation was undertaken was permitted to grow up. State and nation could have prevented it. But it was a long time before public sentiment, which is really the power of the state and of the nation, awakened to the facts, and roused itself to the task of establishing equity in place of gross and unjust discrimination, and law in place of license.

The multitude of evils could not be eliminated nor the wrongs corrected by one heroic action. Under the conditions that then existed such things grew rapidly and easily. The attempt to eradicate them involves the interests of many who had nothing to do with creating or fostering them, as well as the interests of the carriers, whose agents, in co-operation with the representatives of favored ones, created and nourished the wrongs.

Even if it be true that the present financial condition of transportation agencies is due to reckless, improvident, or even dishonest financing in the past, it would be a mistake to undertake to correct it by a policy of reprisal which will impair the usefulness or efficiency of the carriers upon which the welfare—the very life—of the commerce of the country depends. That commerce grows continually, and we have seen, each year, periods during which the available facilities were sadly lacking in capacity and efficiency to properly furnish the transportation demanded.

This is in part due to the failure of carriers to provide themselves with facilities; in part to inefficient handling and movement of equipment; in part to failure of shippers and receivers to provide room and facilities of their own sufficient for their needs, and in part to customs that have grown up in some lines of business which necessarily cause serious delay to cars and congestion of terminals.

Of course, the ideal situation would be one in which the carriers were ready to provide all the equipment needed and promptly transport all the traffic offered at the time of the maximum demand; but that situation can be attained only by large additions to the facilities and great improvement in methods. The added facilities can be secured only through expenditures from surplus earnings or from expansion of credit. In either way the total cost to purchasers of transportation would be increased. It seems to me that no more helpful work can be done than to bring about the highest possible degree of efficiency in the operation and utilization of the facilities now possessed.

It seems to me also that the traveling public is justly entitled to a greater degree of safety while patronizing our railroads. The importance of this should be brought forcefully to the mind of every railroad official and every railroad employee. They should realize and respond to the great responsibilities

which they have undertaken and be held to a strict accountability for neglect therein. It would be well to revive and enforce the old and fundamental rule for train operation, "In case of doubt, take the safe side."

## RAILWAY ELECTRICAL ENGINEERS' ASSOCIATION.

An account of the opening exercises and committee reports of the first two days of the convention of the Association of Railway Electrical Engineers, was published in our last week's issue on page 756. Extracts from other reports of interest follow:

### CAR ILLUMINATION.

L. S. Billan, chairman of the committee, presented the report. An abstract follows: The committee arranged with the co-operation of the Lake Shore & Michigan Southern and with the assistance of the manufacturing concerns directly interested in the subject, to conduct an extensive series of tests on day coach lighting. The tests were held at the Collinwood shops of the Lake Shore at Cleveland, employing a modern 70 ft. coach for the purpose, and lasted about eight weeks. They covered an investigation of the relative engineering merits of center deck and half deck system of location of units, their proper spacing, the efficiency, illumination intensity, and uniformity of all distinctive types of lighting units for both gas and electric lighting suitable for this service. From the results the committee has drawn the following conclusions:

First: Equally satisfactory illumination results from the point of view of efficiency, uniformity of distribution, and absence of objectionable shadows (except where a large number of people are standing in the aisle) are obtained with either the center deck or the half deck arrangement of light units. However, on account of the larger number of units involved, cleaning cost, reflector and lamp maintenance are materially greater with the half deck arrangement.

Second: The uniformity of distribution of illumination obtained with spacing the lighting units three seats (approximately 9 ft.) apart is so poor as not to justify spacing greater than two seats (approximately 6 ft.) where the best illumination results are desired. This does not apply to semi-indirect or indirect lighting where an entirely satisfactory distribution can be obtained with three seat spacing.

Third: With direct lighting systems the color of the head lining has no appreciable effect on the useful illumination produced, except where lighting units are used in which a considerable proportion of light is transmitted to the ceiling. The use of a light colored head lining, however, is recommended, as it produces a more cheerful effect in the car, than where a dark color is used.

Fourth: The results of illumination tests show a wide range in the efficiency of the lighting units, the more efficient units producing over twice the useful illumination, compared on an equal wattage basis. Further, the various lighting units can be classified into groups each possessing distinctive characteristics. Table I shows a comparison of the groups with reference to their illumination efficiency.

Fifth: The illumination values obtained with electric lighting show the desirability of the use of a lamp of greater lumen capacity. Until such a lamp can be available without an increase of its wattage above the present standard train lighting lamps, the use of only the more efficient types of lighting units is recommended where the best results are desired.

*Selection of System.*—In determining the suitability of any system of illumination for passenger carrying cars consideration should be given to the following features, which are stated in the order of their relative importance:

Quality of illumination produced relative to permitting the

eye to see with the least amount of fatigue or discomfort; efficiency and uniformity of distribution; cleaning costs; reflector breakage costs; artistic merit, and fixture installation and maintenance costs.

Bare electric lamps should never be used for general illumination in railway cars, as the high intrinsic brilliancy of the filament makes them very irritating to the eye as well as produces eye fatigue. In addition the efficiency of the bare lamp is very low, the illumination produced on planes where used by passengers with the arrangement and sizes of lamps (half deck system with 15-watt lamps) in use to a considerable extent being but slightly higher than that obtained with some of the better forms of oil lamps. Also the use of a shallow bowl type of reflector should be avoided in which the bare light source can be seen within the normal angle of vision of a passenger when standing in the aisle or sitting in a seat.

Recent tests which have been made, though not of sufficient extent to be entirely conclusive, would indicate that eye fatigue is but slightly reduced with diffuse illumination, as produced by direct lighting units of diffusing type or with semi-indirect lighting units, from that produced with the majority of types of direct lighting units employing open reflectors.

The various kinds of lighting units can be classified in groups possessing more or less distinctive characteristics. Table I shows such a grouping as based on their illumination efficiency, the different types being arranged in the order of their efficiency as measured on the 45 deg. planes. Center deck lighting with two seat spacing was used with all but the semi-indirect and totally indirect lighting units, which were spaced three seats apart.

TABLE I.—ELECTRIC LIGHTING.

Comparison of Various Types of Lighting Units from Point of View of Illumination Efficiency.

All results reduced to same total wattage representing 66½ generated lumens per running foot of car.

Type of Unit.	Average illumination on 45 deg. reading planes, foot candles.			Illumination efficiency, per cent. effective lumens on 45 deg. planes.
	Aisle seats.	Window seats.	Avg. seats.	
Open mouth reflectors—				
Mirrored glass reflectors.....	3.39	2.18	2.79	39.5
Prismatic clear reflectors.....	2.66	2.17	2.42	34.2
Heavy density opal reflectors.....	2.41	1.87	2.14	30.3
Enclosing unit—				
Prismatic reflectors (deep bowl type) and bowl.....	2.15	1.66	1.89	26.7
Open mouth reflectors—				
Medium density opal reflectors.....	2.00	1.65	1.83	25.9
Prismatic satin finish reflectors.....	1.94	1.50	1.72	24.3
Light density opal reflectors.....	1.79	1.52	1.66	23.5
Semi-indirect units.....	1.56	1.24	1.40	19.8
Diffusing shades (standard Pullman opal shade).....	1.42	1.28	1.35	19.1
Enclosing units—				
Reflecting and diffusing globes (satin finish Corona).....	1.44	1.24	1.34	19.0
Reflecting and diffusing type of units.....	1.46	1.18	1.32	18.7
Prismatic reflector (shallow bowl type) and bowl.....	1.39	1.09	1.24	17.5
Totally indirect units.....	1.36	1.11	1.23	17.4
Bare lamp.....	1.17	1.13	1.15	16.3
Enclosing unit, light density opal globe.....	1.09	.97	1.03	14.6

As would be expected, the mirrored glass type of reflector is the most efficient, but on account of being opaque its use can scarcely be considered for direct lighting units for coach service. The clear prismatic type of reflectors come next, followed closely by heavy density type of opal reflector; in fact, one of the deep bowl heavy density opal reflectors tested showed a slightly higher efficiency than a similar shape of clear prismatic reflector. While the illumination from the heavy density opal type falls off at the window seats considerably more than from the clear prismatic type, its efficiency is so high that it should possess considerable attraction for those who object to the appearance and the cleaning question involved of the clear prismatic type, but do not wish to sacrifice efficiency.

Next in order of efficiency is an enclosing type of unit. The units of this type tested consisted of clear prismatic

glass reflector (deep bowl design) with prismatic enclosing bowl, both with and without opal glass envelopes over the reflectors. On account of their higher first cost as well as maintenance costs when compared with open mouth reflectors, their use for day coach lighting would probably be considered prohibitive by most railroads. However, for parlor cars, sleeping cars and similar classes of equipment where it is desired to use lighting units in which the bare light source is entirely concealed and the glare reduced to a minimum yet at the same time possessing high efficiency, this type of unit is to be recommended.

The low efficiency should be noted of the square opal shades recently put in use on Pullman cars. Though higher than that obtained with the sand blasted shades in general use on these cars, they are lower than that obtained with the semi-indirect type of lighting units tested and about equal to that of the satin finish Corona globe extensively used with gas lighting in coach service.

With the exception of the deep bowl reflector type of prismatic glass enclosing unit specially designed for car lighting there was found to be relatively little difference in the efficiencies of the different types of enclosing units tested whose use has been considered to any extent for car lighting service. These units showed but little higher efficiency than indirect lighting without possessing the advantages of that system.

As might be expected, with the comparatively small ceiling area available for reflecting purposes, except in a few forms of passenger car construction, the efficiency of the indirect lighting system is rather low. Except for a few special cases in passenger car lighting where the questions of efficiency and the cost of a very high standard of cleaning both of the lighting units and the ceiling of the car, are of minor importance, the indirect system of lighting cannot be recommended for general use in passenger car lighting until a decided advancement has been made in improving the efficiency of the tungsten lamp.

The fact that because the character of material or form of construction of the lighting unit identifies it as belonging to one of the groups shown in Table I, is not sufficient evidence from which to assume that its illumination efficiency in similar service will correspond to that given. It is essential that the shape of its photometric curve and the lumens produced in the different zones approximate that obtained with the units used in the tests.

Gas Lighting.—The variety of lighting units for gas lighting has never been developed to the extent it has for electric lighting. Table II shows the illumination results and efficiency obtained with some of the lighting units in general use for railway service. The data is on the same basis as that given in Table I except that it represents 130 generated lumens per running foot of car (Pintsch 90 candle power mantle lamps on two seat spacing) instead of 66½ lumens.

TABLE II.—GAS LIGHTING.

Comparison of Various Types of Lighting Units from Point of View of Illumination Efficiency.

Results given on basis representing 130 generated lumens per running foot of car.

Type of Unit.	Average illumination on 45 deg. reading planes, foot candles.			Illumination efficiency, per cent. effective lumens on 45 deg. planes.
	Aisle seats.	Window seats.	Avg. seats.	
Enclosing units—				
Prismatic reflector and bowl, deep bowl type.....	3.65	3.72	3.69	26.8
Reflecting and diffusing globes (clear Corona).....	2.74	2.34	2.54	18.4
Reflecting and diffusing globes (satin finish Corona).....	2.47	2.07	2.27	16.5
Medium density opal diffusing globes.....	2.08	1.52	1.80	13.1
C. R. I. diffusing globes.....	1.92	1.67	1.80	13.1

The prismatic reflector and bowl unit was practically identical with that used in the tests with electric lighting. As was shown with electric lighting, the efficiency of the reflecting

and diffusing type of globes is low. However, on account of the large amount of light produced by gas lamps, the need for using efficient reflectors is not as great as with electric lighting.

*Size of Lamps.*—It will be noted that with the best arrangement of location of lighting units—center deck lighting with two seat spacing and employing the largest standard size of train lighting lamp in general use, the 400 lumen lamp (50-watt)—the illumination obtained on the 45 deg. reading planes is not as high as could be desired, except possibly with the most efficient types of reflectors. The need of a train lighting lamp of higher lumen capacity is indicated, but at the present time none is available except at an increase in wattage, which from an operating point of view is highly undesirable. With the present standard train lighting lamps, therefore, the use of only the more efficient types of lighting units is recommended for electric lighting where the best illumination results are to be obtained.

The discussion brought out the fact that the lamp manufacturers have progressed to such a stage that they will soon be able to make some very pronounced improvements. The question was raised as to whether watts or lumens should be the standard on which to classify lamps. Whichever standard is chosen it should be the real standard and adopted by all railroads.

#### TERMINAL FACILITIES FOR LIGHTING EQUIPMENT.

The report of the committee on this subject was restricted to the description of battery houses with the tools required and the methods of handling the storage batteries to and from the car. The discussion, however, brought out the question as to where the general overhauling of the batteries should take place. Some favored the general car shops, while others favored the terminal coach yards. It was evident that different conditions governed this point. On the Pennsylvania lines east all the batteries are cleaned at one terminal and are not necessarily restricted to the shopping of the car. When the cars are shopped, however, the batteries are taken from the cars and carefully inspected, light repairs being made. The heavy repairs are sent to the main battery repair plant and new batteries substituted. It was found that this work, if distributed amongst various shops, would prove very expensive and that the batteries should not be restricted to car shoppings as the periods of service between shoppings were very different from those of the car. On the New York Central, however, the batteries are cleaned at the main car shops when the car goes in for general repairs, and those batteries not ready to be shopped are taken from the shopped cars and exchanged with those batteries of other cars which are in a bad condition.

#### CHARGING STORAGE BATTERIES.

The committee on this subject presented practically the same report as was presented at the semi-annual convention at Atlantic City last June, being abstracted in the *Daily Railway Age Gazette* of June 17, on page 1428. The members considered in the discussion the question of wiring the charging receptacles throughout the yard in series or in parallel. It was pointed out that the series system was a very unsatisfactory way in which to charge batteries, and should not be used in any case where the multiple system could be used. The multiple system is much more expensive, but saves considerable in the life of the battery.

#### OTHER BUSINESS.

The following officers were elected for the ensuing year: President, C. R. Gilman, chief electrician, Chicago, Milwaukee & St. Paul; first vice-president, H. C. Meloy, chief electrician, Lake Shore & Michigan Southern; second vice-president, E. W. Jansen, electrical engineer, Illinois Central; secretary-treasurer, Joseph A. Andreucetti, general foreman, Chicago & North Western. It was voted that the next annual convention be held at Chicago, and that San Francisco be considered for the semi-annual convention of 1915.

## General News.

The United States Civil Service Commission announces examinations for telegraph and telephone engineer, senior and junior, and for telegraph and telephone inspector for service under the Interstate Commerce Commission in valuation of the property of common carriers.

The Rock Island road has increased the pay of telegraphers five per cent., following protracted negotiations with the employees. Points at issue were adjusted October 28, after conferences conducted through G. Wallace W. Hanger, assistant Federal commissioner of mediation under the Newlands act.

Pierce Butler, of St. Paul, and ex-Governor Herbert S. Hadley, of Missouri, have been retained as joint counsel for the western railways in connection with the valuation of railway property now being made by the Interstate Commerce Commission. Mr. Butler was counsel for the railways in the Minnesota rate case, and also acted as special counsel for the government in the litigation against the meat packers.

About 80 per cent. of the Pullman cars now in operation on the New Haven road are either all steel or of steel underframe and steel end construction, and the Pullman Company has assured Chairman Elliott that by December 31 every Pullman car in use anywhere on the New Haven's lines will be of that character. For some time practically all the sleeping and parlor cars running between New York and Boston have been steel or steel underframe.

The Chicago city council committee on railway terminals has decided to postpone for two weeks final consideration of the report made by John F. Wallace recommending the passage of ordinances asked by the Union Station Company for its proposed passenger terminal and by the Pennsylvania lines for a new freight terminal. This action was taken at the instance of the railways interested, they having asked that the committee await the independent investigation of the terminal question being made by Bion J. Arnold at the expense of a citizens' committee.

The Pennsylvania has discovered a somewhat extensive scheme for selling forged certificates of satisfactory former employment on railroads. Most of the forged letters that have been located so far have purported to come from the Schuylkill division, and they have been presented by applicants in California. The proprietor of a cigar store in San Francisco made a charge of \$1 for a forged letter of recommendation. He had an accomplice in a stenographer in a shop nearby, who, for the sum of 25 cents, would add a few pencil notations to give a letter some look of genuineness. The forged letters first appeared in the summer of 1912, and since then have been appearing with considerable frequency.

The *Railway Age Gazette* denounces noise nuisances at all times and in all places; but as an impartial chronicler of events it must give place to every bit of pleasing evidence about railroad noises, whatever may be its source; and we therefore reprint the following item from the *Macon (Ga.) Telegraph*: For a railroad passenger train's whistle to practically suspend business in a town, and also to run ripples of pleasure over the countenance of a Sunday morning congregation, is something out of the ordinary. Yet that is what the Central of Georgia has done for its Eatonton patrons. So delighted are the citizens along the route of the road that a petition is being spoken of, requesting the Central to keep the whistle in service. [It is a "calliope" whistle.]

The Gray-Thurber automatic train stop, which has been installed for experimental purposes for some time on the Pennsylvania Lines West, near Pittsburgh, was demonstrated before a party of railroad officers on Thursday, October 23. The installation comprises four stop locations on one track. The automatic apparatus is superimposed on the automatic block signal system with which the road is equipped. The special demonstration train followed a local train into the successive blocks and was stopped automatically at each stop signal. Tests were made at speeds varying from 10 to 50 miles an hour, with satisfactory action in every case. On the afternoon of the same day

there was a demonstration on the line of the Pittsburgh (electric) Railways where an electric car has been equipped. The Gray-Thurber company expects to give a demonstration this week in the presence of a committee of Congress. Sixteen Congressmen have promised to be present.

#### Tipsters Called to Account.

The notice reprinted below has been posted in the waiting rooms and corridors of the Union Passenger Station at Portland, Oregon. We are informed that this action has been taken because the tipping evil has grown to be a great annoyance; to such an extent that travelers are embarrassed at every turn through having attentions thrust upon them which they do not desire, but under such circumstances that they hand over a tip rather than appear close or niggardly in the eyes of the porters or of fellow travelers. Others who really require assistance refuse it, feeling that they cannot afford to pay what the porter is supposed to expect. An officer of the company advises that similar action is expected to be taken at all of the other important passenger terminals on the Pacific Coast—Los Angeles, San Francisco, Tacoma, Seattle and Spokane.

#### NORTHERN PACIFIC TERMINAL COMPANY OF OREGON

##### GRAND CENTRAL STATION.

##### Notice to Passengers

Please do not offer tips to Red Cap Porters or other employees in this Station.

The service is provided and paid for by the Terminal Company as a convenience to the public and all employees are prohibited from receiving tips.

#### London & Port Stanley to Be Electrified.

The city of London, Ontario, which owns the London and Port Stanley Railroad, twenty-four miles long, from London southward via St. Thomas to Port Stanley, on Lake Erie, has decided to introduce electric traction, and to operate the road directly. This is the result of a vote of taxpayers taken October 22. The estimated cost of the changes to be made is \$700,000. The vote was 2,820 in favor of electric traction and 2,574 against it. This road appears in the Official Guide under the head of Pere Marquette, with a notation that it is operated by the Lake Erie & Detroit River Railway Company.

#### Facilities Versus Hostilities.

As one of our exchanges very aptly puts it, "Texas needs railroad facilities far more than railroad hostilities." The railroads have so long been the stepping stone of ambitious politicians that it is about the only chartered route to fame and power.

As long as the state rages and frets and bites at the chains of progress there will be a deathlike stillness over our affairs while we weave our own sorrow; but if we are going to make footprints in the sands of time, it will take something more than hostility toward industry to do it. We need railroad facilities instead of railroad hostilities.—*Bulletin of the Texas Commercial Secretaries' and Business Men's Association.*

#### Seniority Not a Presumption of Fitness.

Railroad managers are held responsible by the public and it is from the managers that the public expects whatever action is necessary for safety. The public, through Federal and State commissions, has called on the New Haven road for adequate regulations for the selection of competent men to operate the trains. It is reasonable and just for the public to expect that the management shall be free to take that action. The management has issued new regulations, which make seniority only one of the factors, instead of the chief factor, in determining fitness. In this the management is acting on sound principles. Seniority does not necessarily insure fitness. This is equally true in the army and the navy. It is not necessarily even a presumption of fitness. Whatever danger there is of favoritism must be guarded against in some other way than by the impracticable and rigid application of a seniority rule.

This is not a defense of absolutism in railway management. If there is injustice, the men ought to be heard, by appeal to a body that represents the interests of the public. There is

but one answer to the question, Who is responsible for the safety of passengers on the railway? It is the management. Wise self-interest, as well as public spirit, should impel the employees of the railway to do nothing which will impair the responsibility of the management by impairing its freedom to command and direct its forces.—*The Outlook.*

#### Safety First on the G. T. R.

The Grand Trunk Railway of Canada, on which George Bradshaw has been promulgating "safety-first" ideas, has issued a placard 10 in. x 6½ in., the substance of which is reprinted below. The lettering is blue and red on white cardboard—a red, white and blue effect. At each corner, in the border, is a print of the safety first button.

#### GRAND TRUNK RAILWAY SYSTEM.

##### THE PLEDGE.

I will Railroad according to the Book of Rules. I will do all in my power to guard against unsafe acts on my part. If I see a fellow employee doing his work in an unsafe manner, I will speak to him, as a friend, and use my moral influence to have him perform his duties in the Safest Possible Manner. I will remember and practice at all times SAFETY FIRST.

*EIGHTY-THREE PER CENT.* of all persons injured on railroads are **YOU MEN WHO WORK FOR THE ROADS.**  
*SIXTY-SIX PER CENT.* of all preventable injuries sustained by you are **DUE TO UNSAFE PRACTICES** which you could avoid.

#### Different Degrees of Danger.

Individual drinking cups will not help greatly if the water to be drunk out of them is contaminated, and the charge of Surgeon-General Blue that a great railway company has been supplying its trains from a source polluted with sewage suggests that society may have become prematurely refined about details which are of secondary importance and which may easily distract attention from the vital point. The public drinking cup is not a nice thing and may involve some risk of infection; but a small risk in comparison with the dangers of breathing public air. The drinking-cup reform is praiseworthy but not very important; in comparison with the quality of the liquid which the cup contains it is insignificant. Travelers who otherwise would control their appetite for water are liable to take it for granted that the public health has been safeguarded in every particular.—*Springfield Republican.*

#### Two Months for Manslaughter.

Engineman Caudle, who was held responsible for the rear collision at Aisgill, on the Midland Railway of England, on September 2 (the date of the last railroad disaster in this country), has been sentenced by the court at Carlisle, Scotland, to two months in jail, on a charge of manslaughter; "a nominal penalty," says the despatch. Caudle admitted running past signals set against him, but nevertheless the trade unions are declaring that he has been made a scapegoat, and that the officers of the railroad company are at fault. The claims of the unionists are based on alleged difficulties because the engine was overloaded. Caudle asked for a helping engine, but the request was refused. The coal supplied is alleged to have been so bad as to necessitate incessant stoking and oiling; and attention to the injectors, made necessary by the condition of the engine, monopolized the attention of both engineman and fireman at critical moments. The judge ruled that Caudle accepted all the responsibility, despite these circumstances. The trades unionists retort that he had to do this or lose his job. Caudle passed a caution signal while, or just after he was outside the cab. He had gone around the front of the engine to oil around.

#### Tom. Straw.

The Railroad Young Men's Christian Association, at Haileyville, Okla., on the Rock Island, reports that 95 per cent. of the locomotive engineers running into Haileyville make use of the building; also 80 per cent. of the conductors, 85 per cent. of the firemen, 60 per cent. of the brakemen and 50 per cent. of the switchmen. Testimonials from these men have been given as follows:

Engineer: "A man who would not appreciate what the Rock

Island has done for us in the gift of this building would not appreciate his own mother."

Engineer: "I never had any use for a Y. M. C. A.—the fact is I never had been in one. Now I have two homes, one at the other end of the line where I live and here at the Railroad 'Y.' It is a second home to me."

Conductor: "I had put up with conditions as long as I could possibly stand and was looking for a change to some other section of the country. Now I have decided to stay."

Brakeman: "I have not boozed any since the 'Y.' opened, and spend all my time in the building."

Fireman: "The porch alone is worth the price of a year's membership."

Railroad Clerk: "Life is not quite so monotonous now. I was going to quit and go north; but me for Haileyville."

Fireman: "This secretary, Tom Straw, has shown me that I have been living on a mighty low plane. I tell you clean surroundings, a decent place to play pool, a good bed, good, wholesome food, goes a long ways toward helping a man to keep straight. Why, I even wash cleaner than I used to."

Brakeman: "My wife is a booster for the Railroad Y. M. C. A. She says since I have been stopping here I actually cuss less and treat the children and herself the way I did during the first years of our married life."

Engineer: "No man can imagine what a new man this building makes of a fellow. I used to be always tired and fussing when I came from a run. Now I feel ten years younger."

A Minister: "A better moral tone already prevails in our community."

A Business Man: "We have begun to realize how narrow we were and on what a low plane we were all living. This secretary, Tom Straw, is the biggest asset Haileyville has. Where do you get such men for your Y. M. C. A. work?"

Switchman: "I am taking a new interest in my job. 'Taint quite so stale around this burg now."—*Rock Island Employee's Magazine.*

#### Trains Need Not Be Delayed for Late Mail.

Postmaster General Burleson has issued an order amending Section 1354 of the new edition of the postal laws and regulations to provide that where the holding of a train for the loading of mail from a delayed connection would seriously delay the train, the department may authorize its departure when the letter and daily newspaper mails have been loaded if a subsequent available train is due to depart within a reasonable time. It is also provided that at points where trains are held for mails from connections during the weighing period, upon the results of which adjustments of pay on the routes are based, the railroads will be required to maintain the conditions with respect to holding the trains that obtained during such weighing periods.

This change of the regulations has been advocated by the railroad companies for a number of years and only a few months ago the matter was presented to the department by a committee representing several of the railroads, but no action was taken until recently when it was brought to the personal attention of Mr. Burleson by Guy Adams, manager of mail traffic of the Frisco Lines and the Chicago & Eastern Illinois, who represented that the schedules of passenger trains throughout the country were being seriously interfered with because of holding trains at certain points for the loading of all the mail, on account of the enormous quantities of parcel post packages. After careful consideration of the matter, the regulations were changed, thus removing restraints upon the expeditious operation of passenger trains and at the same time duly subserving the best interests of the postal service.

#### Investment Bankers' Association.

The second annual convention of the Investment Bankers' Association of America was held on October 28, 29 and 30, at the Blackstone hotel, Chicago. Papers on railroad subjects read at the convention include "Railroad Bonds and Equipment Notes," by George G. Henry, of New York, and "Railroad Bonds," by John E. Blunt, Jr., vice-president, Merchants Loan and Trust Company, Chicago. At the banquet on Thursday evening James J. Hill delivered an address dealing

with present conditions in the investment world, an abstract of which appears in another column. In his address as president of the association, George B. Caldwell, of the Continental & Commercial Trust & Savings Bank, Chicago, spoke on the subject of "Railroad Financing" as follows:

We have, during the past year, been brought face to face with a new form of railroad financing. The plea of the railroads for higher rates because of decreased profits apparently does not strike the popular mind with the same force as the suggestion that the public safety and convenience require large capital outlays for automatic signals and steel cars, better track and stations; and that to raise that capital the railroads must show a good margin over their fixed charges and fair dividends. There is another side to this question on which the railroads must be alert. They must offer new capital issues with the best of security at their disposal. Short-term notes, convertible bonds, equipment issues, all at high rates of interest and requiring refinancing and duplication of bankers' commissions, lawyers' and other fees and expenses, have for a long time been liberally supplied in the attempt to effect a slight saving in the interest rate. The money is obtained at high rates, but responsibility for really financing the companies is only deferred, and later long-term issues must be negotiated. Still another experience is now being faced by many roads which have exhausted their prior lien bond issues and have been forced to other kinds of secondarily secured issues, instead of creating a blanket mortgage sufficiently comprehensive to provide for the entire system, amply secured by present and future property and resources. If a company has any credit, such mortgage bonds under clearly drafted measures as to the purposes for which they can be issued, should net far better prices than any attempts to use miscellaneous forms of security issues which have nothing to commend them but the small aggregate amount of the mortgage or indenture covering their issue, which is exhausted in about twenty years, and then drives the company to further creations of sectional or divisional mortgages. Some of the companies have awakened, such as the Chicago, Burlington & Quincy with its \$300,000,000 mortgage; the Great Northern under Mr. Hill's foresight with a \$600,000,000 mortgage, the Interborough Rapid Transit with one for \$300,000,000, the Southern Railway for \$300,000,000, the Pennsylvania for \$1,000,000,000, and the New York Central with a mortgage having no fixed principal sum except a limitation of not exceeding three times the par value of the capital stock at any time outstanding, which it hopes to have authorized. It is the opinion of railroad experts that it will result in cheaper financing and a stronger form of security, eventually becoming the first lien on the system. The first mortgages on most roads are now exhausted, or nearly so, and this broad basis for future comprehensive railroad financing must become the rule and not the exception. The creation of mortgages for railroads and public utility companies for larger amounts than in the past must be expected if the country is to be well served. The investor and dealer alike should appreciate a standardization of methods of financing, as well as forms of mortgages.

#### Car Foremen's Association of Chicago.

The annual election of officers of the Car Foremen's Association of Chicago, held October 13, 1913, resulted as follows: President, George F. Laughlin, general superintendent, Armour Car Lines; first vice-president, C. J. Wymer, general foreman, Belt Railway; second vice-president, A. Le Mar, master mechanic, Pennsylvania Railroad; treasurer, M. F. Covert, assistant master car builder, Swift & Company; secretary, Aaron Kline, 841 North Fiftieth court, Chicago. The election was followed by a banquet, vaudeville and dance. The association is in a prosperous condition, having a membership of 876 practical car men.

#### American Railway Association.

W. F. Allen, general secretary, 75 Church street, New York, announces that the fall meeting of the American Railway Association will be held at The Blackstone, Chicago, November 19. Reports will be presented by the executive committee and the committees on transportation; on maintenance; on automatic

train stops; on relations between railroads; on explosives and on electrical working.

#### Railway Business Association.

Howard Elliott, chairman of the New York, New Haven & Hartford Railroad, and James M. Cox, governor of Ohio, are announced as the speakers for the fifth annual dinner of the Railway Business Association, which will be held at the Waldorf-Astoria hotel, New York, Thursday evening, December 11. The business meeting of the association occurs at 11 a. m. at the Waldorf, the election of officers at 1:30 p. m., and the dinner at 7 p. m.

#### American Society of Mechanical Engineers.

A paper on a new centrifugal pump with helical impeller will be presented on Tuesday evening, November 11, by C. V. Kerr, sales engineer of the A. S. Cameron Steam Pump Works, New York. Discussion will follow in which all are invited to take part. An informal dinner (à la carte) will be served at 6:30 p. m. Those desiring to participate should notify H. R. Cobleigh, 505 Pearl street, New York.

#### June Mechanical Conventions.

A meeting of the executive committees of the Railway Supply Manufacturers', the Master Car Builders' and the Master Mechanics' Associations will be held at the Vanderbilt Hotel, New York, at 10 a. m., Tuesday, November 4, to formulate plans for the conventions to be held next year.

#### MEETINGS AND CONVENTIONS.

*The following list gives names of secretaries, dates of next or regular meetings, and places of meeting.*

**AIR BRAKE ASSOCIATION.**—F. M. Nellis, 53 State St., Boston, Mass. Next convention, May, 1914.

**AMERICAN ASSOCIATION OF DEMURRAGE OFFICERS.**—A. G. Thomason, Boston, Mass. Convention, May 19, 1914, St. Louis.

**AMERICAN ASSOCIATION OF GENERAL PASSENGER AND TICKET AGENTS.**—W. C. Hope, New York.

**AMERICAN ASSOCIATION OF FREIGHT AGENTS.**—R. O. Wells, East St. Louis, Ill. Next convention, April 21, Houston, Tex.

**AMERICAN ASSOCIATION OF RAILROAD SUPERINTENDENTS.**—E. H. Hartman, St. Louis, Mo.; 3d Thursday and Friday in May.

**AMERICAN ELECTRIC RAILWAY ASSOCIATION.**—H. C. Donecker, 29 W. 39th St., New York.

**AMERICAN ELECTRIC RAILWAY MANUFACTURERS' ASSOC.**—H. G. McConaughy, 165 Broadway, New York. Meetings with Am. Elec. Ry. Assoc.

**AMERICAN RAILWAY ASSOCIATION.**—W. F. Allen, 75 Church St., New York. Next meeting, November 19, 1913, Chicago.

**AMERICAN RAILWAY BRIDGE AND BUILDING ASSOCIATION.**—C. A. Lichty, C. & N. W., Chicago. Next convention, October 20-22, 1914, Los Angeles, Cal.

**AMERICAN RAILWAY ENGINEERING ASSOCIATION.**—E. H. Fritch, 900 S. Michigan Ave., Chicago. Next convention, March 17-20, Chicago.

**AMERICAN RAILWAY MASTER MECHANICS' ASSOCIATION.**—J. W. Taylor, Old Colony building, Chicago.

**AMERICAN RAILWAY TOOL FOREMEN'S ASSOCIATION.**—A. R. Davis, Central of Georgia, Macon, Ga.

**AMERICAN SOCIETY FOR TESTING MATERIALS.**—Prof. E. Marburg, University of Pennsylvania, Philadelphia, Pa.

**AMERICAN SOCIETY OF CIVIL ENGINEERS.**—C. W. Hunt, 220 W. 57th St., New York; 1st and 3d Wed., except June and August, New York.

**AMERICAN SOCIETY OF ENGINEERING CONTRACTORS.**—J. R. Weninger, 11 Broadway, New York; 2d Tuesday of each month, New York.

**AMERICAN SOCIETY OF MECHANICAL ENGINEERS.**—Calvin W. Rice, 29 W. 39th St., New York.

**AMERICAN WOOD PRESERVERS' ASSOCIATION.**—F. J. Angier, B. & O., Baltimore, Md. Next convention, January 20-22, 1914, New Orleans, La.

**ASSOCIATION OF AMERICAN RAILWAY ACCOUNTING OFFICERS.**—C. G. Phillips, 143 Dearborn St., Chicago. Annual meeting, May 28, Atlantic City, N. J.

**ASSOCIATION OF RAILWAY CLAIM AGENTS.**—C. W. Egan, B. & O., Baltimore, Md. Next convention, May, 1914, St. Paul, Minn.

**ASSOCIATION OF RAILWAY ELECTRICAL ENGINEERS.**—Jos. A. Andreucetti, C. & N. W. Ry., Chicago.

**ASSOCIATION OF RAILWAY TELEGRAPH SUPERINTENDENTS.**—P. W. Drew, 112 West Adams St., Chicago. Next convention, May 20-23, New Orleans, La.

**ASSOCIATION OF TRANSPORTATION AND CAR ACCOUNTING OFFICERS.**—G. P. Conard, 75 Church St., New York. Next meeting, December 9-10, Galveston, Tex.

**ASSOCIATION OF WATER LINE ACCOUNTING OFFICERS.**—W. R. Evans, Chamber of Commerce, Buffalo, N. Y.

**BRIDGE AND BUILDING SUPPLY MEN'S ASSOCIATION.**—L. D. Mitchell, Detroit Graphite Co., Detroit, Mich. Meeting with American Railway Bridge and Building Association.

**CANADIAN RAILWAY CLUB.**—James Powell, Grand Trunk Ry., Montreal, Que.; 2d Tuesday in month, except June, July and Aug., Montreal.

**CANADIAN SOCIETY OF CIVIL ENGINEERS.**—Clement H. McLeod, 413 Dorchester St., Montreal, Que.; Thursday, Montreal.

**CAR FOREMEN'S ASSOCIATION OF CHICAGO.**—Aaron Kline, 841 North 50th Court, Chicago; 2d Monday in month, Chicago.

**CENTRAL RAILWAY CLUB.**—H. D. Vought, 95 Liberty St., New York; 2d Thurs. in Jan. and 2d Fri. in March, May, Sept., Nov., Buffalo, N. Y.

**CIVIL ENGINEERS' SOCIETY OF ST. PAUL.**—L. S. Pomeroy, Old State Capital building, St. Paul, Minn.; 2d Monday, except June, July, August and September, St. Paul.

**ENGINEERS' SOCIETY OF PENNSYLVANIA.**—E. R. Dasher, Box 704, Harrisburg, Pa.; 1st Monday after second Saturday, Harrisburg, Pa.

**ENGINEERS' SOCIETY OF WESTERN PENNSYLVANIA.**—E. K. Hiles, Oliver building, Pittsburgh; 1st and 3d Tuesday, Pittsburgh, Pa.

**FREIGHT CLAIM ASSOCIATION.**—Warren P. Taylor, Richmond, Va. Next convention, May 20-22, Galveston, Tex.

**GENERAL SUPERINTENDENTS' ASSOCIATION OF CHICAGO.**—E. S. Koller, 226 W. Adams St., Chicago; Wed. preceding 3d Thurs., Chicago.

**INTERNATIONAL RAILWAY CONGRESS.**—Executive Committee, 11, rue de Leevain, Brussels, Belgium. Convention, 1915, Berlin.

**INTERNATIONAL RAILWAY FUEL ASSOCIATION.**—C. G. Hall, 922 McCormick building, Chicago. Annual convention, May 18-22, Chicago.

**INTERNATIONAL RAILWAY GENERAL FOREMEN'S ASSOCIATION.**—Wm. Hall, 829 West Broadway, Winona, Minn. Next convention, July, Chicago.

**INTERNATIONAL RAILROAD MASTER BLACKSMITHS' ASSOCIATION.**—A. L. Woodworth, Lima, Ohio. Next convention, third Tuesday in August.

**MAINTENANCE OF WAY & MASTER PAINTERS' ASSOCIATION OF THE UNITED STATES AND CANADA.**—W. G. Wilson, Lehigh Valley, Easton, Pa. Next convention, November 18-20, Louisville, Ky.

**MASTER BOILER MAKERS' ASSOCIATION.**—Harry D. Vought, 95 Liberty St., New York.

**MASTER CAR BUILDERS' ASSOCIATION.**—J. W. Taylor, Old Colony building, Chicago.

**MASTER CAR & LOCOMOTIVE PAINTERS' ASSOC. OF U. S. AND CANADA.**—A. P. Dane, B. & M., Reading, Mass.

**NATIONAL RAILWAY APPLIANCE ASSOC.**—Bruce V. Crandall, 537 So. Dearborn St., Chicago. Meetings with Am. Ry. Eng. Assoc.

**NEW ENGLAND RAILROAD CLUB.**—W. E. Cade, Jr., 683 Atlantic Ave., Boston, Mass.; 2d Tuesday in month, except June, July, Aug. and Sept., Boston.

**NEW YORK RAILROAD CLUB.**—H. D. Vought, 95 Liberty St., New York; 3rd Friday in month, except June, July and August, New York.

**NORTHERN RAILROAD CLUB.**—C. L. Kennedy, C. M. & St. P., Duluth, Minn.; 4th Saturday, Duluth.

**PEORIA ASSOCIATION OF RAILROAD OFFICERS.**—M. W. Rotchford, Union Station, Peoria; 2d Thursday.

**RAILROAD CLUB OF KANSAS CITY.**—C. Manlove, 1008 Walnut St., Kansas City, Mo.; 3d Friday in month, Kansas City.

**RAILWAY BUSINESS ASSOCIATION.**—Frank W. Noxon, 2 Rector St., New York. Annual dinner, second week in December, 1913, New York.

**RAILWAY CLUB OF PITTSBURGH.**—J. B. Anderson, Penna R. R., Pittsburgh, Pa.; 4th Friday in month, except June, July and August, Pittsburgh.

**RAILWAY ELECTRICAL SUPPLY MANUFACTURERS' ASSOC.**—J. Scribner, 1621 Monadnock Block, Chicago. Meetings with Assoc. Ry. Elec. Engrs. Mobile, Ala.

**RAILWAY FIRE PROTECTION ASSOCIATION.**—C. B. Edwards, Mobile & Ohio, Mobile, Ala.

**RAILWAY GARDENING ASSOCIATION.**—J. S. Butterfield, Lee's Summit, Mo.

**RAILWAY DEVELOPMENT ASSOCIATION.**—W. Nicholson, Kansas City Southern, Kansas City, Mo. Next meeting, November 11-12, Baltimore, Md.

**RAILWAY SIGNAL ASSOCIATION.**—C. C. Rosenberg, Bethlehem, Pa.

**RAILWAY STOREKEEPERS' ASSOCIATION.**—J. P. Murphy, Box C, Collinwood, Ohio.

**RAILWAY SUPPLY MANUFACTURERS' ASSOC.**—J. D. Conway, 2135 Oliver bldg., Pittsburgh, Pa. Meetings with M. M. and M. C. B. Assoc.

**RAILWAY TEL. & TEL. APPLIANCE ASSOC.**—W. E. Harkness, 284 Pearl St., New York. Meetings with Assoc. of Ry. Teleg. Sups.

**RICHMOND RAILROAD CLUB.**—F. O. Robinson, Richmond, Va.; 2d Monday except June, July and August.

**ROADMASTERS' AND MAINTENANCE OF WAY ASSOCIATION.**—L. C. Ryan, C. & N. W., Sterling, Ill.

**ST. LOUIS RAILWAY CLUB.**—B. W. Frauenthal, Union Station, St. Louis, Mo.; 2d Friday in month, except June, July and Aug., St. Louis.

**SIGNAL APPLIANCE ASSOCIATION.**—F. W. Edmonds, 3868 Park Ave., New York. Meeting with annual convention Railway Signal Association.

**SOCIETY OF RAILWAY FINANCIAL OFFICERS.**—C. Nyquist, La Salle St. Station, Chicago.

**SOUTHERN ASSOCIATION OF CAR SERVICE OFFICERS.**—E. W. Sandwich, A. & W. F. Ry., Montgomery, Ala.

**SOUTHERN & SOUTHWESTERN RAILWAY CLUB.**—A. J. Merrill, Grant Bldg., Atlanta, Ga.; 3d Thurs., Jan., March, May, July, Sept., Nov., Atlanta.

**TOLEDO TRANSPORTATION CLUB.**—J. G. Macomber, Woolson Spice Co., Toledo, Ohio; 1st Saturday, Toledo.

**TRACK SUPPLY ASSOCIATION.**—W. C. Kidd, Ramapo Iron Works, Hillaburn, N. Y. Meetings with Roadmasters' and Maintenance of Way Association.

**TRAFFIC CLUB OF CHICAGO.**—W. H. Wharton, La Salle Hotel, Chicago.

**TRAFFIC CLUB OF NEW YORK.**—C. A. Swope, 290 Broadway, New York; 1st Tuesday in month, except June, July and August, New York.

**TRAFFIC CLUB OF PITTSBURGH.**—D. L. Wells, Eric, Pittsburgh, Pa.; meetings monthly, Pittsburgh.

**TRAFFIC CLUB OF ST. LOUIS.**—A. F. Versen, Mercantile Library building, St. Louis, Mo. Annual meeting in November. Noonday meetings October to May.

**TRAIN DESPATCHERS' ASSOCIATION OF AMERICA.**—J. F. Mackie, 7122 Stewart Ave., Chicago. Next convention, June 16, Jacksonville, Fla.

**TRANSPORTATION CLUB OF BUFFALO.**—J. M. Sells, Buffalo; first Saturday after first Wednesday.

**TRANSPORTATION CLUB OF DETROIT.**—W. R. Hurley, L. S. & M. S., Detroit, Mich.; meetings monthly.

**TRAVELING ENGINEERS' ASSOCIATION.**—W. O. Thompson, N. Y. C. & H. R., East Buffalo, N. Y. Next meeting, Chicago.

**UTAH SOCIETY OF ENGINEERS.**—Fred D. Ulmer, Oregon Short Line, Salt Lake City, Utah; 3rd Friday of each month, except July and August.

**WESTERN CANADA RAILWAY CLUB.**—W. H. Rosevear, P. O. Box 1707, Winnipeg, Man.; 2d Monday, except June, July and August, Winnipeg.

**WESTERN RAILWAY CLUB.**—J. W. Taylor, Old Colony building, Chicago; 3d Tuesday of each month, except June, July and August.

**WESTERN SOCIETY OF ENGINEERS.**—J. H. Warder, 1735 Monadnock Block, Chicago; 1st Monday in month, except July and August, Chicago.

## Traffic News.

The next meeting of the Western Classification Committee is to be held at Monterey, Cal., on January 13, 1914.

A meeting of the Official Classification Committee will be held at New York on November 11, and a preliminary meeting will be held at Chicago on November 6, for consideration of recommendations of the Committee on Uniform Classification.

In a hearing before the Public Service Commission at Boston this week, representatives of the express companies said that the introduction of the parcel post had been followed by a reduction of 40 per cent. in the amount of their suburban merchandise traffic out of Boston.

The United Typothetæ of America, at a meeting in New Orleans last week, adopted resolutions urging upon the Interstate Commerce Commission "the necessity of giving thorough consideration at the earliest possible date to the application recently filed by the railroads for permission to increase freight rates."

The Chicago Transportation Association has established an educational bureau. Meetings will be held in the club rooms twice a month, at which traffic subjects will be discussed by various speakers. The first meeting on November 5 will be addressed by G. H. Whittle, assistant general agent of the American Express Company.

The Great Northern and the Minneapolis, St. Paul & Sault Ste. Marie have announced that they will apply the Minnesota state freight rates, upheld by the recent decision of the Supreme Court, to traffic between Duluth and other Minnesota points. These roads have not heretofore done so because their lines to Duluth run partly in Wisconsin.

The Southern Railway announces that beginning November 17 the new steamships *City of Richmond* and *City of Annapolis* will be put in regular service between Baltimore, Md., and West Point, Va., and that a steamboat train with a parlor car will be run in connection, between West Point and Richmond, going through without intermediate stops.

The Southern Railway announces that beginning November 16, a new train is to be run between New York and Atlanta, to be known as the "Atlanta Special." It will run on the present schedule of the New Orleans Limited, which will be changed so as to run later in both directions. Both trains will be high class and will have only Pullman cars. With this addition there will be four high class through trains daily in each direction between New York and Atlanta over the Southern Railway.

The Chicago & North Western has announced that it will, on November 1, discontinue the service of the White Audit System, which furnishes train auditors for checking passenger train collections on a number of roads. The North Western will employ its own men as train auditors. About twelve men will be required, and they will report to the general superintendent. The reasons given for the change are that the conductors are less inclined to resent auditing by fellow employees than by men employed by a private agency, and that the work can be carried on more successfully by the company itself.

The passenger department of the Chicago & North Western has established representatives in 18 of the principal cities of Europe, including London, Liverpool, Glasgow, Southampton, Antwerp, Rotterdam, Paris, Havre, Marseilles, Rome, Genoa, Naples, Berlin, Hamburg, Bremen, Frankfurt, Copenhagen and Christiania. These representatives are experienced men, qualified to plan itineraries, quote rates, check baggage and arrange for payment of customs; and they will supply maps and descriptive matter and assist in arranging all minor details incident to a trip from Europe to and through America.

A committee of the Mercantile Exchange, New York City, will ask the Interstate Commerce Commission to suspend the new rules, covering delivery of eggs, filed by the Erie, the New York Central and the Lackawanna. The chief cause of complaint is that the rules do not allow of examination at point of delivery by the consignee except in instances where the cases show external evidence of damage. The rules do

not cover shipments in apparent good order. The committee will demand the same treatment that is accorded to egg merchants in Boston and Philadelphia. It will be recalled that there have been extensive frauds at New York in connection with claims for damage to eggs in transit.

### Boston In Danger.

The transportation committee of the Boston Chamber of Commerce, D. O. Ives, chairman, announces that action will be taken in the courts to prevent the enforcement of the recent order of the Interstate Commerce Commission requiring, in substance, that the rates on import freight traffic, west-bound, over the railroads from the Atlantic seaboard, must be the same from Boston as from New York. Mr. Ives says:

"Ever since freight rates have been published all rail rates on imports from Boston, westward have always been lower than those from New York, and during a large part of the last two decades the rates have been lower from Boston than from Baltimore and Philadelphia.

"For three years, 1906-07-08, when Boston had a 70 cent rate, Philadelphia 69 cents, Baltimore 67 cents, and New York 75 cents, Boston carried 14.1 per cent. of the traffic, Baltimore 34.4 per cent., Philadelphia 20.4 per cent. and New York 31.1 per cent. From 1909 to June 30, 1911, Boston carried 13.3 per cent., Baltimore 28.7 per cent., Philadelphia 18.8 per cent. and New York 39.2 per cent., showing that even under the reduced rate from Boston, Boston lost rather than gained, and New York, in spite of its comparatively high rates, increased from 31.1 per cent. average for 1906-07-08 to a 39.2 per cent. average for 1909-10-11, Baltimore and Philadelphia also losing. In other words, New York gained at the expense of the other ports, although its rates were made higher proportionately.

"These figures were available to the Interstate Commerce Commission but were apparently given little attention, the decision being based on the technicality that it would be discrimination for a line like the New York Central, serving both New York and Boston, to charge less from Boston than from New York.

"It is not quite clear whether the order is applicable to the Boston roads (it says that a carrier must not make rates from New York which will exceed those which it makes from Boston), for the commission has no authority to order rates advanced. The Boston roads were willing in 1908 to run the risk of a rate war to secure a 67 cent rate, as against the 70 cent rate. Today they are threatened with this 75 cent rate, and it is believed that the enforcement of the advance would close the port of Boston to this traffic. This being the case, it can be readily understood that both the Chamber and the railroad officers feel that the matter requires heroic action."

### Car Surpluses and Shortages.

Arthur Hale, chairman of the committee on relations between railroads of the American Railway Association in presenting statistical bulletin No. 153-A, giving a summary of car surpluses and shortages by groups from July 4, 1912, to October 15, 1913, says: The total surplus on October 15, 1913, was 37,198 cars; on October 1, 1913, 41,994 cars, and on October 10, 1912, 22,810 cars. Compared with the preceding period, there is a decrease in the total surplus of 4,796 cars, of which 1,451 is in box, 208 in flat, 1,939 in coal and 1,198 in miscellaneous car surplus. The decrease in box car surplus is in groups 3 (Ohio, Indiana, Michigan and western Pennsylvania); 4 (the Virginias and Carolinas); 6 (Iowa, Illinois, Wisconsin and Minnesota); 7 (Montana, Wyoming, Nebraska and the Dakotas), and 8 (Kansas, Colorado, Oklahoma, Missouri and Arkansas). The decrease in flat car surplus is in groups 2 (New York, New Jersey, Delaware, Maryland and eastern Pennsylvania); 3, 8 (as above), and 9 (Texas, Louisiana and New Mexico). The decrease in coal car surplus is in all groups, except 1 (New England lines); 6 (as above), and 11 (Canadian lines). The decrease in miscellaneous car surplus is in groups 4, 6, 7, 8 (as above), and 10 (Washington, Oregon, Idaho, California, Nevada and Arizona).

The total shortage on October 15, 1913, was 43,246 cars; on October 1, 1913, 31,620 cars, and on October 10, 1912, 54,389 cars.

Compared with the preceding period; there is an increase in



the total shortage of 11,626 cars, of which 7,743 is in box, 153 in flat, 2,109 in coal and 1,621 in miscellaneous car shortage. The increase in box car shortage is in all groups, except 1 and 2 (as above). The increase in flat car shortage is in all groups except 6, 9 and 10 (as above). The increase in coal car shortage is in all groups, except 1, 6 and 11 (as above). The increase in miscellaneous car shortage is in groups 3, 6, 7 and 11 (as above).

Compared with the corresponding period of 1912; there is an increase in the total surplus of 14,388 cars, of which 9,935 is in box, 1,877 in flat, 3,053 in miscellaneous, and a decrease of 477 in coal car surplus. There is a decrease in the total shortage of 11,143 cars, of which 7,728 is in box, 1,966 in flat, 2,395 in coal, and an increase of 946 in miscellaneous car shortage.

The accompanying table gives car surplus and shortage figures by groups for the last period covered in the report and the diagram shows total bi-weekly surpluses and shortage from 1907 to 1913.

**Express Rates to Be Reduced.**

Walker D. Hines, counsel for the Adams, the American, the Southern, the United States and the Wells-Fargo Express Companies, has notified the Interstate Commerce Commission that these companies have decided to comply with the order of the commission issued recently, requiring radical reductions in rates for the transportation of merchandise. This decision has been reached by the companies notwithstanding the fact that they estimate that their revenues will suffer to the extent of from 15 to 25 per cent. The reductions are to go into effect December 1, or as soon as the companies can prepare the tariffs. Mr. Hines' statement says that the companies hope by this action to win the confidence of the commission and also of the state commissions and the public.

The new rates are to be based on a tabulated statement of 650,000 rates which has been issued by the commission as a basis for express rate charges throughout the United States. This document fills over 1,100 pages, 9 in. x 12 in.

**CAR SURPLUSES AND SHORTAGES.**

Date	No. of roads.	Surpluses				Shortages					
		Box.	Flat.	Coal and hopper.	Other kinds.	Box.	Flat.	Coal and hopper.	Other kinds.		
Group *1.—October 15, 1913.....	7	0	0	86	131	217	375	151	0	3	529
" 2.—" 15, 1913.....	30	853	32	719	411	2,015	1,083	2	2,301	26	3,412
" 3.—" 15, 1913.....	28	306	21	200	1,040	1,567	4,116	206	2,612	1,696	8,630
" 4.—" 15, 1913.....	13	3,127	692	705	486	5,010	4,062	472	5,028	569	10,131
" 5.—" 15, 1913.....	23	38	131	125	307	601	1,721	235	1,048	50	3,054
" 6.—" 15, 1913.....	33	1,480	298	1,072	2,408	5,258	2,657	165	350	379	3,551
" 7.—" 15, 1913.....	4	34	40	15	166	255	689	9	51	138	887
" 8.—" 15, 1913.....	18	2,132	279	1,163	1,586	5,160	498	62	227	30	817
" 9.—" 15, 1913.....	14	3,025	192	424	770	4,411	160	0	27	18	285
" 10.—" 15, 1913.....	22	2,817	941	1,485	5,747	10,990	1,080	204	166	282	1,732
" 11.—" 15, 1913.....	6	824	330	20	540	1,714	8,580	604	692	422	10,296
<b>Total .....</b>	<b>198</b>	<b>14,636</b>	<b>2,956</b>	<b>6,014</b>	<b>13,592</b>	<b>37,198</b>	<b>25,021</b>	<b>2,110</b>	<b>12,502</b>	<b>3,613</b>	<b>43,246</b>

\*Group 1 is composed of New England lines; Group 2—New York, New Jersey, Delaware, Maryland and Eastern Pennsylvania lines; Group 3—Ohio, Indiana, Michigan and Western Pennsylvania lines; Group 4—West Virginia, Virginia, North and South Carolina lines; Group 5—Kentucky, Tennessee, Mississippi, Alabama, Georgia and Florida lines; Group 6—Iowa, Illinois, Wisconsin and Minnesota lines; Group 7—Montana, Wyoming, Nebraska, North Dakota and South Dakota lines; Group 8—Kansas, Colorado, Missouri, Arkansas and Oklahoma lines; Group 9—Texas, Louisiana and New Mexico lines; Group 10—Washington, Oregon, Idaho, California, Nevada and Arizona lines; Group 11—Canadian lines.

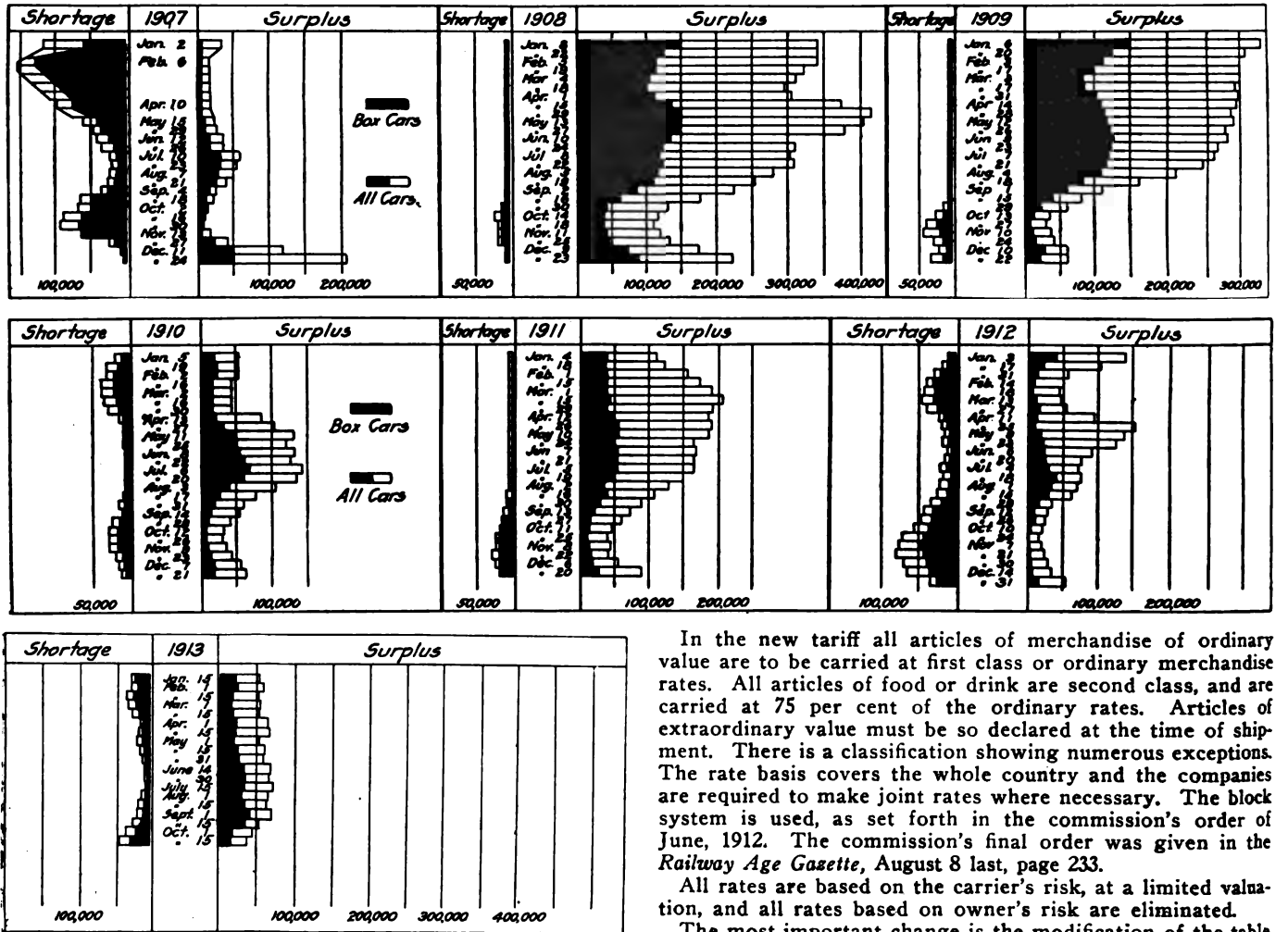

Car Surpluses and Shortages 1907 to 1913.

In the new tariff all articles of merchandise of ordinary value are to be carried at first class or ordinary merchandise rates. All articles of food or drink are second class, and are carried at 75 per cent of the ordinary rates. Articles of extraordinary value must be so declared at the time of shipment. There is a classification showing numerous exceptions. The rate basis covers the whole country and the companies are required to make joint rates where necessary. The block system is used, as set forth in the commission's order of June, 1912. The commission's final order was given in the *Railway Age Gazette*, August 8 last, page 233.

All rates are based on the carrier's risk, at a limited valuation, and all rates based on owner's risk are eliminated. The most important change is the modification of the table of graduated charges for shipments weighing less than 100

lbs. At present there is no uniform basis for computing such rates.

#### INTERSTATE COMMERCE COMMISSION.

The commission has further suspended from November 15 until May 15 proposed advanced rates on fresh meats from St. Louis, Omaha and other points to points in Oklahoma.

The commission has suspended from November 22 until May 22 tariffs by which it was proposed to increase rates on flour from points in Kansas and other western states to California.

The commission has further suspended from November 20 until May 20 certain increased rates on fruits and vegetables between points in California, Nevada and other western states.

The commission has further suspended from November 8 until May 8 a Chicago & Eastern Illinois tariff by which it was proposed to advance rates on coal from mines in Indiana and Illinois to points in Iowa.

#### Volco, Fifth Class.

*Volco Mfg. Co. v. Atchison, Topeka & Santa Fe. Opinion by Commissioner Meyer:*

The complainant's petition for the establishment of low commodity rates on eastbound shipments of its product not granted. The reduction of the present rates to a level suggested by the findings in the *Kansas Rate case* allowed.

The Volco Manufacturing Company, Wichita, Kans., makes a cleansing compound composed chiefly of a so-called volcanic ash, a considerable deposit of which, located at Anthony, Kans., about 57 miles southwest of Wichita, is owned by the complainant. It is desired to extend its field of usefulness. (28 I. C. C., 289.)

#### Rates to Montezuma Reduced.

*City of Montezuma, Ga., v. Central of Georgia et al. Opinion by Chairman Clark:*

Upon complaint that freight rates from the Ohio river crossings, the Virginia cities and eastern cities to Montezuma, Ga., are unreasonable, unjustly discriminatory, and in violation of the long-and-short-haul rule; *Held*, That the rates complained of are unjustly discriminatory against Montezuma and dealers thereat, and unduly preferential to Cordele and Americus, Ga., and dealers thereat. No finding is made as to the long-and-short-haul feature of complaint, as that question is before the commission for the entire southeastern territory in another proceeding and upon a voluminous record. (28 I. C. C., 280.)

#### Sandstone, Minn.; Building Stone Rates.

*Opinion by Chairman Clark:*

Respondents published joint commodity rates on building, curbing and paving stone from Sandstone and Banning, Minn., to Kansas City, Omaha and other Missouri river points, and provided in their tariff that upon request therefor they would establish rates no higher from intermediate points. Upon request for the establishment of such rates from an intermediate point, respondents filed cancellation of the rates from Sandstone and Banning; *Held*, That respondents have failed to show that the resulting increased rates would be reasonable; that the existing rates are, and for the future will be, reasonable; and that respondents should establish rates no higher from intermediate points upon proper request therefor. (28 I. C. C., 269.)

#### Sheridan and Kirby Coal Rates Reduced.

*Sheridan Chamber of Commerce v. Chicago, Burlington & Quincy et al. Opinion by Commissioner Meyer:*

Rehearing. The original hearing dealt with rates on coal from Sheridan, Wyo., to destination on the Chicago & North Western in Nebraska and South Dakota, on the Chicago, Milwaukee & St. Paul in South Dakota, and on the Northern Pacific east and west of Billings, Mont. Upon the rehearing the Big Horn Collieries Company, Owl Creek Coal Company, and Board of Railroad Commissioners of Montana were granted leave to intervene. The first two ask that the rates from mines near Kirby, Wyo., be adjusted so as to bear a proper relationship to rates established from Sheridan to destinations in the three cases under consideration. *Held*:

Sheridan coal should move to points upon the Chicago &

North Western and the Pierre, Rapid City & Northwestern herein involved at the same rate enjoyed by Hudson. Proper routing for coal moving from Sheridan to these destinations is prescribed.

Joint rates should be established from Kirby to destinations on the Chicago & North Western and the Pierre, Rapid City & Northwestern herein involved no higher than one dollar above the rates prescribed from Sheridan.

For distances within 500 miles of the point of origin joint rates should be established from Sheridan to points on the Northern Pacific east of Billings not more than 40 cents over those prevailing from Red Lodge, and to points west of Billings 55 cents over Red Lodge, and from Kirby to points on the Northern Pacific east and west of Billings joint rates should be established not more than 65 cents over the prevailing rates from Red Lodge. To points between 500 and 600 miles from Sheridan the differentials suggested as compared with rates from Red Lodge should be decreased 10 cents, and for each 100 miles additional a further reduction of 10 cents should be made in the differential.

It is possible for a carrier to discriminate unjustly and unlawfully against a point which it does not reach over its own rails.

The difference in cost of production cannot be recognized as a basis for the adjustment of freight rates between different localities. (28 I. C. C., 250.)

#### STATE COMMISSIONS.

The Railroad Commission of Louisiana has announced a hearing, to be held on November 7, to consider the adoption of an order requiring all railroads in Louisiana to employ and keep in service at least one competent flagman in addition to the brakeman, on all trains operating in the state.

The California Railroad Commission has issued a general order directing all steam and electric railways in the state to provide sanitary individual drinking cups for passengers at a cost not to exceed one cent a cup. These must be provided on all trains whose schedule between terminals exceeds 1 hour and 30 minutes.

Express companies operating in Wisconsin have agreed to accept, in place of the recent order of the state railroad commission, requiring them to reduce their rates on merchandise in Wisconsin 20 per cent., a supplementary order requiring them to reduce their rates on all classes of articles to rates similar to those recently established by the Interstate Commerce Commission.

The Public Utility Commissioners of New Jersey have issued a general memorandum in which they say that the commission will interpret the law which says that no corporation using right-of-way, etc., shall "issue, sell and deliver its bonds, notes or obligations of any character except in return for cash to the extent of at least 80 per centum of the face value of said securities issued or for property of an actual cash value of at least 80 per centum of the face value of the securities issued in payment therefor," as applying to the issue of bonds to be deposited as collateral under notes or other loans. The commission, however, apparently doubts whether or not under the statute railroads would be permitted to issue bonds as collateral for loans under any circumstances.

#### COURT NEWS.

Leo V. Hahn and T. F. Ryan, doing business as the Imperial Rice Company of Houston, have pleaded guilty in the Federal Court in Texas to an indictment charging them with obtaining unlawful concessions on interstate shipments of rice.

In the Federal Court at New York City, on Tuesday last, Henry A. Dix entered a plea of guilty and was fined \$500 for false classification of freight shipped by his firm, Henry A. Dix Sons & Co., makers of women's dresses. The Grand Jury has found indictments for a similar offense against the American Thermo-ware Co. for shipping optical instruments classed as hardware. The United States District Attorney is investigating charges against 150 firms in New York City alleging fraud against the railroads. The most numerous class of offenders consists of dealers in millinery, feathers and artificial flowers.

## Railway Officers.

### Executive, Financial and Legal Officers.

E. C. Smith, of St. Albans, Vt., and formerly governor of Vermont, has been elected president of the Central Vermont, succeeding E. J. Chamberlin.

J. C. Brinton, secretary to the president of the Erie, has been appointed an assistant secretary of the company, with headquarters at New York.

J. P. Blair, for a number of years general counsel for Southern Pacific interests in Louisiana, has been appointed general counsel of the Southern Pacific Company, with headquarters at New York, succeeding Maxwell Evarts, deceased. Mr. Blair was born at Columbus, Miss., and graduated from the University of Virginia in 1882, with the degree of master of arts. He was for two years professor of mathematics at the University of Louisiana. He studied law during this time, and began the practice of law in 1884. Soon afterwards he became a member of the firm of Leovy & Blair, and has been connected with the Southern Pacific Company during practically the whole of its corporate life and of his professional life.

W. T. Stringer, chief clerk to the president of the Western Maryland at Baltimore, Md., has been appointed to the new position of assistant to the president and C. H. Porter, who has been in the office of the president for the past six months, succeeds Mr. Stringer. In 1898 Mr. Stringer entered the service of the Western Maryland as a stenographer in the office of the general auditor and has been in the continuous service of that road ever since. He was later transferred to the traffic department and then was again transferred to the operating department. In 1905 he was appointed secretary to vice-president and general manager, and subsequently was promoted to chief clerk, and at the time of his recent appointment as assistant to president was chief clerk to the president of the same road.

Thomas Milton Schumacher, vice-president of the El Paso & Southwestern System at New York, has been elected chairman of the board of the Chicago, Rock Island & Pacific Railway and of the Rock Island Company, succeeding D. G. Reid, also chairman of the executive committee of both companies, succeeding W. H. Moore. He was born on February 16, 1862, at Williamsport, Pa., and began railway work in 1879 as a telegraph operator for the Atlantic & Great Western. He then served in various positions on different roads in the operating department as operator, and in the train service until 1883, when he became clerk in the Missouri Pacific local office at St. Louis, Mo. From 1885 to 1887, he served as cashier, chief clerk and contracting agent at St. Louis of the Cleveland, Columbus, Cincinnati & Indianapolis. In 1887, he became chief clerk in the office of the general agent of the Union Pacific at Omaha, Neb., and three years later was made general agent of that road at San Francisco, Cal., which position he held four years. He was subsequently for two years vice-president and general manager of the Continental Fruit Express, with headquarters at Chicago, with the exception of about six months from November 1, 1901, when he resumed his former position. Mr. Schumacher was then until September, 1905, traffic manager of the Oregon Short Line, and subsequently for a short time was traffic manager of the United Fruit Company at New York. In 1906 he was made general traffic man-



T. M. Schumacher.

ager of the railroads and industrial companies controlled by Phelps, Dodge & Company of New York, with headquarters at Chicago, where he remained until December 1, 1909 when he resigned to accept the vice-presidency of the Denver & Rio Grande and Western Pacific, with office at San Francisco. Mr. Schumacher was appointed assistant director of traffic of the Union Pacific and Southern Pacific systems on May 1, 1910, with headquarters at Chicago, and on December 1, of that year, became traffic manager of the American Smelting & Refining Company and its allied companies with offices at New York. On November 1, 1912, he became vice-president of the El Paso & Southwestern system, also vice-president of the Nevada Northern and the Bingham & Garfield.

### Operating Officers.

E. E. McClellan has been appointed general superintendent of the San Benito & Rio Grande Valley, with headquarters at San Benito, Tex., succeeding E. S. Heyser, resigned.

The title of F. A. Redmond, acting manager fuel oil properties of the Gulf, Colorado & Santa Fe, is changed to manager fuel oil properties, with headquarters at Galveston, Tex.

G. N. Howson, master mechanic of the Southern Railway at Princeton, Ind., has been appointed superintendent of the St. Louis and Louisville divisions, with headquarters at Louisville, Ky., succeeding F. W. Brown, resigned.

The office of J. Cannon, superintendent of the Eastern division of the Missouri Pacific, has been transferred from Sedalia, Mo., to Jefferson City, Mo. D. H. Robinson, trainmaster of the St. Louis district at Sedalia, has been appointed assistant superintendent at that place.

### Traffic Officers.

F. D. Daggett has been appointed assistant general passenger agent of the San Antonio & Aransas Pass at San Antonio, Tex.

M. J. Hannam, commercial agent of the St. Paul & Kansas City Short Line at Minneapolis, Minn., has been appointed general freight and passenger agent of the San Antonio, Uvalde & Gulf, with headquarters at San Antonio, Tex.

T. F. Ellzey, commercial agent of the Missouri & North Arkansas at New Orleans, La., has been appointed traveling freight agent of the Missouri Pacific, Denver & Rio Grande and Western Pacific, with headquarters at New Orleans.

Roy B. Campbell has been appointed city ticket and passenger agent of the Minneapolis & St. Louis at Des Moines, Iowa, to succeed C. M. Brown, who was transferred to Minneapolis, Minn., as rate clerk in the general passenger department.

R. G. Smock, district freight agent of the St. Paul & Kansas City Short Line at Des Moines, Ia., has been appointed commercial agent of the Chicago, Rock Island & Pacific at that point. O. B. McNamee, contracting freight agent of the former road, has been appointed traveling freight agent of the Rock Island, with headquarters at Des Moines.

J. D. Watson having resigned as assistant general freight agent of the St. Louis Southwestern to become vice-chairman of the executive committee of the Southwestern Traffic Committee, the duties heretofore performed by him have been assigned to J. E. Allen, assistant general freight agent at St. Louis, Mo. W. S. Cornell is appointed assistant general freight agent at St. Louis. Effective November 1.

F. A. Leland, chairman of the Executive Committee of the Southwestern Tariff Committee, having been assigned certain duties concerning the preparation for the defense of carriers in complaints pending before the Interstate Commerce Commission, involving rate adjustments in the committee tariffs, J. D. Watson is appointed vice-chairman, and will be connected with the work referred to. Headquarters St. Louis, Mo.

### Engineering and Rolling Stock Officers.

Isaac Maxwell Taylor, general roadmaster of the Northern Pacific at Glendive, Mont., has been transferred to Forsyth, Mont., as roadmaster, in place of Gustav Gullickson, who has been granted six months' leave of absence.

G. M. Stone has been appointed master mechanic of the Oklahoma division of the Rock Island Lines, with headquarters

at Chickasha, Okla., succeeding W. J. O'Neill, who has been appointed master mechanic of the Pan Handle and the Indian Territory divisions, with office at Shawnee, Okla., in place of C. A. McCarthy, resigned to accept service with another company.

Charles W. Johnson, who November 1 becomes consulting engineer of the Chicago, St. Paul, Minneapolis & Omaha, with



C. W. Johnson.

headquarters at St. Paul, Minn., as mentioned elsewhere, was born January 20, 1845, at Johnstown, N. Y. He was graduated from Union College at Schenectady, N. Y., in the class of 1866, and began railway work January 3, 1867, in the assistant chief engineer's office of the Michigan Southern & Northern Indiana. From May, 1870, to January, 1871, he was assistant engineer of construction of the Chicago & Northwestern, and from February, 1871, to November, 1878, he was successively assistant engineer and division engineer of the Wisconsin Central. Mr. Johnson went to the

Chicago, St. Paul & Minneapolis, March 1, 1879, as chief engineer, which position he has held continuously for over 34 years with that road and its successor, the Chicago, St. Paul, Minneapolis & Omaha. He is now made consulting engineer, with office at St. Paul, as mentioned above, after a railway service of 47 years.

H. Rettinghouse, who has been appointed chief engineer of the Chicago, St. Paul, Minneapolis & Omaha, with headquarters at St. Paul, Minn., as stated elsewhere, was born in Germany on



H. Rettinghouse.

July 30, 1861. He was educated in Germany, and came to the United States in 1882, beginning railway work in 1883 as rodman on construction work on the St. Paul extension of the Wisconsin Central. The following year he became connected with the Milwaukee, Lake Shore & Western, now a part of the Chicago & North Western, and was successively leveler, instrument man and assistant engineer in charge of location, construction and maintenance. Mr. Rettinghouse was engaged in a general engineering business at Ashland, Wis., from 1893 to 1897, including three years'

service as city engineer of that city. He then returned to the North Western, and was assistant engineer in charge of construction and maintenance until May, 1900, and from the latter date to February, 1905, was superintendent of bridges and buildings of the Ashland division. He was then division engineer of the Southern division of the Wisconsin Central, resigning in January, 1907, to become division engineer of the Chicago & North Western at Boone, Iowa, in charge of maintenance of East Iowa, West Iowa and Iowa & Minnesota divisions. In April, 1912, he was made superintendent of the Iowa & Minnesota division at Mason City, Iowa, from which position he is

now promoted to chief engineer of the Chicago, St. Paul, Minneapolis & Omaha, a subsidiary line of the North Western.

C. W. Johnson, chief engineer of the Chicago, St. Paul, Minneapolis & Omaha, has been appointed consulting engineer, with headquarters at St. Paul, Minn. H. Rettinghouse, superintendent of the Iowa & Dakota division of the Chicago & North Western at Mason City, Iowa, succeeds Mr. Johnson as chief engineer of the former road, with office at St. Paul. Effective November 1.

Robert Quayle, whose appointment as general superintendent of the motive power and car departments of the Chicago & North Western is announced elsewhere, was born at Douglas, Isle of Man. He



Robert Quayle.

began railway work with the Chicago & North Western in 1871 as machinist apprentice and until June, 1885, was successively journeyman machinist, gang boss and foreman. He was then promoted to the position of master mechanic and nine years later, on December 1, 1894, was made superintendent of motive power and machinery. After serving in the latter capacity for 19 years he will on November 1 become general superintendent of the motive power and car departments, with headquarters at Chicago, as above noted. Mr.

Quayle was president of the Railway Master Mechanics' Association 1898-1899.

H. T. Bentley, assistant superintendent of motive power and



H. T. Bentley.

machinery of the North Western, who will succeed Mr. Quayle as superintendent of motive power and machinery, as mentioned elsewhere, was born June 4, 1862. He was educated at Dulwich College, and began railway work in 1877 with the London & North Western of England, where he was employed as an apprentice machinist until 1887. He was then for five years foreman of enginehouse of the same road at Chester, England. In 1892 he began to work for the Chicago & North Western as machinist at the Chicago shops. Later he was made foreman

of shops at Boone, Iowa, and from 1895 to 1898 was foreman at Belle Plaine, Iowa. He was then general foreman at Clinton, Iowa, and subsequently from April 1 to December 30, 1899, was master mechanic of the Madison division. Mr. Bentley was transferred to the Iowa division as master mechanic on January 1, 1900, where he remained until August 31, 1902, when he was appointed assistant superintendent of motive power and machinery at Chicago, and, as stated above, on November 1 he will be promoted to superintendent of motive power and machinery. Mr. Bentley was president of the Western Railway Club 1906-1907; president of the American Railway Master Mechanics' Association

1911-1912, and president of the International Railway Fuel Association 1912-1913. He is chairman of the sub-committee of mechanical officials of the General Managers' Association of Chicago for the prevention of smoke in the city of Chicago, and also is a member of the Headlight Committee of the Master Mechanics' Association. Mr. Bentley also is a member of the American Society of Mechanical Engineers.

Robert Quayle, superintendent of motive power and machinery of the Chicago & North Western, has been appointed general superintendent of the motive power and car departments, and H. T. Bentley, heretofore assistant superintendent of motive power and machinery, succeeds Mr. Quayle, both with headquarters at Chicago. C. A. Schroyer, superintendent of the car department, and Mr. Bentley will report to Mr. Quayle. Effective November 1.

E. M. Sweetman, master mechanic of the Southern Railway at Birmingham, Ala., has been appointed master mechanic, with headquarters at Princeton, Ind., succeeding G. N. Howson, appointed superintendent. Frank Johnson, master mechanic at Sheffield, Ala., succeeds Mr. Sweetman; J. W. Gibbs, master mechanic of the Virginia & Southwestern at Bristol, Tenn., succeeds Mr. Johnson, and E. L. Akans has been appointed master mechanic of the Virginia & Southwestern, with office at Bristol, Va. Tenn., succeeding Mr. Gibbs.

B. B. Milner, assistant master mechanic of the Philadelphia, Baltimore & Washington at Wilmington, Del., has been appointed special engineer on the staff of the senior vice-president of the New York Central lines, with headquarters at New York. He began railway work as a machinist's helper in the Parsons, Kans., shops of the Missouri, Kansas & Texas, resigning in 1900, to enter the mechanical engineering school of Purdue University from which he graduated in 1904. He then entered the service of the Pennsylvania Railroad as special apprentice at the Altoona shops. From September, 1904, to 1905 he was engaged in work under E. D. Newson, engineer of tests and chairman of the committee appointed by the Association of Transportation Officers to investigate the "Low Mileage of Freight Car Equipment," and then was special representative of the superintendent of motive power, returning to regular machine and erecting shop work for a time. In the fall of 1905 he was again assigned by the engineer of tests to special work investigating and preparing a report on relations existing between speed and load in freight train performance, and the following year was engaged in planning a rearrangement in the location of machine tool equipment at the Altoona shops. During the first half of 1908, he was sent to the West to visit the principal railroad shops for the collection of ideas on betterment methods and practices, and for a short time was engaged in putting these into effect. He was then engaged in special work under the direction of the assistant to general manager of the Pennsylvania Railroad at Philadelphia, including a study of betterment problems, and in May, 1911, was appointed assistant master mechanic at Wilmington, Del., but was temporarily relieved of his duties in 1912 to handle the preparation under the general manager at Philadelphia of the Pennsylvania's case for presentation to board arbitrating in 1912 the enginemen's demands for increases in wages and adjustments of working conditions. He was engaged in similar work in the firemen's arbitration in 1913, under the direction of the chairman of the Conference Committee of Managers, and since January, 1913, when he was relieved of those duties he has been engaged as assistant master mechanic at Wilmington.

#### Purchasing Officers.

D. C. Curtis, for the past three years inspector of stores of the Chicago, Burlington & Quincy, with headquarters at Chicago, has been appointed scrap expert for the Panama Canal Commission, with headquarters at Colon, Panama. The duties of Mr. Curtis have to do with the disposing of the machinery and other second hand and scrap material left from the construction of the Panama canal.

#### OBITUARY.

E. S. Prindiville, traveling passenger agent of the Chicago, Burlington & Quincy, at Pittsburgh, Pa., died on October 20,

in that city, at the age of 31. He was born in Chicago, and began railway work in October, 1902, as a clerk on the Burlington, and had been in the continuous service of that road ever since. In 1903 he was made cashier, and later became passenger agent. Since 1906 he had been traveling passenger agent of the same road, at Pittsburgh.

George F. Lee, general baggage agent of the Chicago, Rock Island & Pacific, died suddenly at his home in Chicago on October 24, aged 53 years. Mr. Lee began railway work in 1877 as ticket, freight and general agent of the Baltimore & Ohio. He was northwestern passenger agent of the Chicago, Rock Island & Pacific from 1881 to 1884, then returning to the Baltimore & Ohio for four years as general agent. He again became connected with the Rock Island in 1888, and was successively general agent of the passenger department, ticket agent and city passenger agent, with headquarters at Chicago, general agent of the passenger department, and since 1905, general baggage agent.

Frank E. Brown, first assistant general passenger agent of the Boston & Maine, at Boston, Mass., died at his home in Concord, N. H., on October 27. He was born in 1850, at Claremont, N. H., and entered railway work in August, 1868. He was clerk and bookkeeper in the cashier's office, until 1880, and was subsequently superintendent's clerk and then was general ticket agent of the Concord Railroad. From January, 1890, to July, 1895, he was general passenger and ticket agent of the Concord & Montreal, and in July, 1895, was appointed assistant general passenger and ticket agent of the Boston & Maine (which absorbed the C. & M.), with headquarters at Concord. Since October, 1910, he had been first assistant general passenger agent, and also was general passenger agent of the Mount Washington Railway.

William Osbourne Sprigg, formerly superintendent of the New York division of the Lehigh Valley, died on October 26, at his home in Tompkinsville, Staten Island, N. Y. He was born in 1865, at Cumberland, Maryland, and began railway work in March, 1879, as a rodman and levelman on the George's Creek & Cumberland. He was subsequently assistant engineer of the Baltimore & Cumberland Valley, now a part of the Western Maryland; assistant engineer of the Pittsburg & Western and then to December, 1882, was engineer of construction. In December, 1882, he was appointed master of road on the Baltimore & Ohio, and three years later became engineer of maintenance of way of the New York extension of the same road. From September, 1886, to November, 1894, he was master of transportation of the Staten Island Rapid Transit Railroad, and then was superintendent of the same road. In May, 1897, he was appointed division superintendent of the Southern Railway, and from September, 1898, to August, 1904, was superintendent of the New York division of the Lehigh Valley. He then left railway work to organize the General Contracting & Engineering Company, of which he was president at the time of his death.

Benjamin W. Carskaddon, real estate agent of the Pennsylvania Railroad, with office at Philadelphia, Pa., died on October 23, at Atlantic City, N. J. He was born in February, 1858, at Philadelphia, and received a public school education in that city. He studied conveyancing and attended the real estate law course at the University of Pennsylvania. In February, 1879, he entered the service of the Pennsylvania Railroad in the office of the general solicitor as a conveyancer; but he resigned three years later to go into the real estate business in Pittsburgh. He returned to the service of the railroad company in March, 1885, as agent at Pittsburgh for the real estate department, and had been in the service ever since. From January, 1893, to January, 1900, he was in the office of the real estate agent at Philadelphia, in charge of the branch of that department relating to the taxation of real estate; and then was assistant real estate agent until his appointment, in May, 1902, as real estate agent in charge of the department. In his capacity as real estate agent Mr. Carskaddon has for many years had supervision of the road's real estate transactions, which are numerous and important. One of these was the purchase of the land for the Pennsylvania station and its approaches in and around New York City, involving many millions of dollars and several years' time.

## Equipment and Supplies.

### LOCOMOTIVE BUILDING.

THE PENNSYLVANIA SOUTHERN has ordered 1 consolidation locomotive from the Baldwin Locomotive Works.

THE MOBILE & OHIO has ordered 7 mikado locomotives, and 7 consolidation locomotives from the Baldwin Locomotive Works.

THE VREDENBURGH SAW MILLS, Vredenburgh, Ala., has ordered 1 ten-wheel locomotive from the Baldwin Locomotive Works.

THE OCONTO COMPANY, Oconto, Wis., has ordered 1 six-coupled double ender locomotive from the Baldwin Locomotive Works.

THE MOORE TIMBER COMPANY, Panama City, Fla., has ordered 1 six-coupled double ender locomotive from the Baldwin Locomotive Works.

THE GRAYLING LUMBER COMPANY, Charleston, W. Va., has ordered 1 six-coupled double ender locomotive from the Baldwin Locomotive Works.

THE LEHIGH & NEW ENGLAND RAILROAD, and the Lehigh Coal & Navigation Company are in the market for 5 consolidation locomotives and 3 switching locomotives.

THE CHICAGO & NORTH WESTERN has ordered 12 Pacific type passenger locomotives, and 18 six-wheel switching locomotives from the American Locomotive Company. The passenger locomotive will have 25 in. x 28 in. cylinders; 75-in. driving wheels; a steam pressure of 170 lbs., and a total weight in working order of 260,000 lbs. The switching locomotives will have 18 in. x 24 in. cylinders; 51-in. driving wheels, a steam pressure of 180 lbs., and a total weight in working order of 141,000 lbs. All these locomotives will be equipped with superheaters.

### CAR BUILDING.

THE MAINE CENTRAL is in the market for 10 caboose cars.

THE BANGOR & AROOSTOOK is in the market for 68 flat cars.

THE CHICAGO & ILLINOIS MIDLAND has ordered 250 coal cars from the Haskell & Barker Car Company.

THE CHICAGO, BURLINGTON, & QUINCY has ordered 100 tank cars from the American Car & Foundry Company.

THE CUMBERLAND VALLEY has ordered 13 all-steel, 70-ft. passenger coaches, and 3 all-steel 70-ft. combination passenger and baggage cars from the American Car & Foundry Company.

THE MINNEAPOLIS, ST. PAUL & SAULT STE. MARIE is said to have ordered 500 box cars and 500 coal cars from the American Car & Foundry Company. This item has not been confirmed.

THE LEHIGH & NEW ENGLAND, reported in the *Railway Age Gazette* of October 24, as making inquiries for 250 fifty-ton hopper cars, is now inquiring for 500 hopper cars and 200 gondola cars.

THE MOBILE & OHIO has ordered 522 fifty-ton steel double drop bottom gondola cars from the Pressed Steel Car Company, and 20 steel underframe 8-wheel caboose cars from the Lenoir Car Works.

### IRON AND STEEL.

THE NEW YORK CENTRAL LINES have ordered 5,000 tons of titanium open-hearth rails.

### SIGNALING.

The Philadelphia & Reading is to install a new mechanical interlocking plant at Yardley, Pa., on its New York division, to have 36 levers. The contract for manufacture and installation has been given to the Federal Signal Company, Albany, N. Y.

The track circuits in connection with this interlocking will have alternating current, the first a. c. track circuits, we believe, to be used in signaling on the Reading.

The New York Central has awarded the order for telephone selector equipment for the West Shore Line, Albany to South Utica, to the General Railway Signal Company, Rochester, N. Y. This circuit comprises 42 selector stations and is 118 miles in length, the dispatcher's office being located at Albany. The order specifies G. R. S. power equipment, including an A. C.-D. C. motor generator set and a power switch board with accessories. The motor generator will be operated from a 25-cycle, 110 volts commercial circuit, which is available at the dispatcher's station.

The Chicago & Western Indiana has awarded the Union Switch & Signal Company a contract for the installation of electro-pneumatic push-button plants at the eastbound and westbound Chicago clearing yards. The layouts of the two yards are identical, each containing 65 single switches, and each push-button cabinet will have 60 working buttons for the switches and four working buttons for controlling the two one-arm electro-pneumatic three-position signals at each plant provided for governing movements to the yards over the two approaching tracks. Available alternating current at 60 cycles, 2,300 volts will be stepped down to 220 volts and fed through the plants for feeding the track circuits. A total of 61 track circuits is to be provided for at each of the yards, with two track circuits being fed from each track circuit transformer.

THE UGANDA RAILWAY, EAST AFRICA.—The Uganda Railway, with a length of about 584 miles, is owned by the state. The line runs from Mombasa to Port Florence on Victoria Nyanza, on which lake there is a connecting steamer service. There is also a branch line under construction from Nairobi to the Thiba river, about 31 miles in length.

ELECTRIFICATION OF SWISS RAILWAYS.—The question of the electrification of the Swiss government railways is being seriously considered. The question of electrification of all Swiss railways is one of vital importance to the federal government because of the fact that Switzerland is dependent on the surrounding countries for its supply of fuel, no coal being produced in the country, whereas it is rich in natural water power resources. Swiss federal engineers are watching with much interest the experiment of operating the Loetschberg line by electricity, and there is little doubt that the Gothard will be equipped with electric motive power as soon as the success of the Loetschberg experiment is demonstrated. A special staff of engineers has been engaged for some time in the preparation of plans for the change on the Gothard, and a favorable report has been made by the government commission appointed to investigate and report on the feasibility of electrification.

YUNNAN RAILWAY, CHINA.—While the breaking out of new disorders in South China prevented immediate activity in the enterprise, except a continuation of survey work already in hand, there is every indication that the construction of the railway from the West River country at or near Nanning, Kwangsi province, China, to Yunnan-fu and thence into West China will be commenced just as soon as the state of the country justifies action. The construction of this line offers special inducements to American capital, as political interests of other nations likely to serve in this connection prevent action on the part of either or any of them—a state of checkmate or a balancing of interests into which American interests can or will have no part and in which therefore American capital can act with freedom and with less opposition than might be expected under other conditions. The line was at first projected from Yunnan-fu to Nanning, there to connect with water transportation by the West River with Wuchow and Canton and Hongkong. For the time being the line is to be constructed to Poseh, a point on the river a considerable distance above Nanning, which is the head of navigation for small boats, and to and from which freight can be handled by boats at present with some degree of freedom, though with more or less difficulty owing to the varying stages of water in the rivers, bad rapids and falls, and various other impediments. Some of these impediments can be removed with comparatively little expense and it is a part of the present plan to improve the means of navigation on the rivers in connection with construction of the railway.

## Supply Trade News.

J. R. Wiley, manager of the Standard Underground Cable Company, Pittsburgh, Pa., died on August 17.

The Kelly Reamer Company, Cleveland, Ohio, has increased its common stock from \$25,000 to \$50,000 to add facilities for its business.

The Southwestern Steel Development Company of Houston, Tex., has announced its intention of establishing a large steel plant, rolling mills and coking plant at Texas City, Tex., involving an expenditure of about \$10,000,000.

The Chicago-Cleveland Car Roofing Company has let building contracts for an addition to its Cleveland works and the work is now under way. The entire Cleveland plant is now operated by individual electric motors recently installed. Besides the Cleveland plant, this company is now manufacturing at three different points in Canada.

The officers of the American Locomotive Company have been re-elected. This action followed the annual stockholders' meeting of the company, which was held on October 21, and at which the board of directors was re-elected. Isaac M. Cate, a stockholder at Baltimore, had made certain charges earlier in the year which had been referred to a committee of the board of directors for investigation. President Marshall made an address in which he replied to Mr. Cate's criticisms. A heated discussion followed, in which among other things several of the shareholders demanded that the report of the special investigating committee be made public when it was completed.

The Transue & Williams Company, Alliance, Ohio, has purchased all of the assets of the Davies-Bach Manufacturing Company, including the plant recently erected in Alliance for making steel stampings. It is expected to operate this plant, which is to be known as the steel stamping department of the Transue & Williams Company, and also to enlarge it materially in order to conduct a general steel stamping business. The company also expects to add from 60 to 80 per cent. to the capacity of its present drop forge plant, and is now contracting for new buildings and additional machinery. When the new equipment is in place, about two hundred additional men will be employed.

### TRADE PUBLICATIONS.

**WATERS GRAB BUCKET.**—A 15 page booklet just issued by the Whiting Foundry Equipment Company, Harvey, Ill., describes and illustrates the Watters quick-detachable grab bucket for foundry use. This catalog is No. 104, and will be sent free on request.

**COALING STATION.**—The Roberts & Schaefer Company, Chicago, Ill., have just issued a four page pamphlet describing their Holman coaling station. The general features of design and the claims for this station are described, accompanied by photographs and drawings of a number of typical recent installations.

**MILLING MACHINES.**—The Cincinnati Milling Machine Company, Cincinnati, Ohio, has issued a 128-page illustrated catalogue of its milling machines, plain, universal and vertical; high-power with constant speed drive; cone-driven; also its milling machine attachments, semi-automatic manufacturing millers and universal cutter and reamer grinders.

**GYRATORY CRUSHERS.**—The Austin Manufacturing Company, Chicago, has issued catalog 27, devoted especially to the Austin gyratory crusher, which is built in eight sizes ranging in capacity from 5 to 600 tons per hour. The catalog includes complete detailed descriptions and illustrations of the various parts, and descriptions of some of the work on which it has been employed.

**GROUND WIRE CLAMP.**—W. E. Belcher, Bloomfield, N. J., has issued a pamphlet relating to the Belcher ground wire clamp. The pamphlet discusses briefly the subject of transmission line protection and describes in detail a new device for the attachment and support of the continuous ground wire, now generally used on high voltage lines. Cuts are shown of two styles, one for pole lines and one for steel tower lines.

## Railway Construction.

**ARKANSAS INTERURBAN.**—This company has issued stock, it is said, to secure funds for building from Little Rock, Ark., southwest to Hot Springs, about 55 miles. W. H. Garanto, president, and L. Garrett, secretary and manager, Little Rock.

**CHICAGO, BURLINGTON & QUINCY.**—The new Thermopolis-Casper line has been opened for business from Thermopolis, Wyo., via Bonneville, and Arminto, to Powder River, 94 miles east of Thermopolis. (October 3, p. 637.)

**GREENE COUNTY.**—This company, which operates a line from Apalachee, Ga., to Good Hope, 13 miles, has given a contract to S. N. Hughes, Bostwick, Ga., it is said, to build an extension from Good Hope, northwest to Monroe, 6.8 miles.

**LAKE ERIE & YOUNGSTOWN.**—An officer writes that the general contract has been given to C. E. Coon, Youngstown, Ohio, to build a double track line from Youngstown, Ohio, via Andover to Conneaut, 66 miles, and 10 miles of sidings, also 6 miles of spur lines. The line will have 1 per cent. grade, and the work involves handling about 30,000 cu. yds. to the mile. The improvements include construction of harbor facilities at Conneaut on Lake Erie. The company expects to develop a traffic in iron ore, coal, coke and farm products. J. H. Ruhlman, president, Youngstown, Ohio. (September 5, p. 436.)

**NEW YORK SUBWAYS.**—The New York Public Service Commission, First district, has about completed the plans for the elevated line through New Utrecht avenue, in the borough of Brooklyn, and will ask for bids for its construction at once. It also has the plans for the Gravesend avenue, or Culver line, well under way, and will advertise for bids for its construction within a short time. Plans are approaching completion for the two new tunnels under the East river—one for operation by the Interborough Rapid Transit Company, and the other by the New York Municipal Railway Corporation, and these should be ready to advertise for bids before the end of the year. Plans for the Eastern parkway subway in the borough of Brooklyn and its connections are also well advanced. The first sections of the line, from the end of the existing subway, out Flatbush avenue to Eastern Parkway, will be submitted to bidders within a short time. In the borough of the Bronx three separate lines for the new subway system will soon be under construction, as follows: The Pelham Bay Park branch, the Jerome avenue branch and the White Plains road branch. The plans for these branches are nearly completed, and a large portion of the work will be under contract in November. The commission has consented to the assignment from the John F. Stevens Construction Company to the Richard Carvel Company of the contract for section No. 1 of routes Nos. 19 and 22, the Southern boulevard and Westchester avenue branch of the Lexington avenue subway. This work calls for building a three-track subway from Alexander avenue through 138th street, and Southern boulevard to about 147th street.

**OKLAHOMA, NEW MEXICO & PACIFIC.**—According to press reports, this company, which is building a line from Ardmore, Okla., west to Waurika, has opened for operation the section between Ardmore and Lone Grove. John Ringling is back of the project. (August 15, page 313.)

**ONEIDA & WESTERN.**—Contracts are to be let soon, it is said, to build a section of 10 miles from Oneida, Tenn., west. The company plans to build in all about 25 miles. R. J. Moscorp, chief engineer, Oneida.

**ROCKCASTLE RIVER.**—Under this name a line is to be built from East Bernstadt, Ky., it is said, north to McKee, about 25 miles. C. C. Williams, Mt. Vernon, may be addressed.

**SAN ANTONIO, UVALDE & GULF.**—An officer writes that work has been finished on the section from Pleasanton, Tex., to Mathis, and work is now under way by Ward & Lee, Mathis, from Mathis to Corpus Christi, 40 miles. The work involves handling about 30,000 cu. yds. to the mile. There will be a number of steel bridges on the line, including a draw span over Nueces river, which is now being built by the company's forces. A. R. Pondor, president and general manager, Pleasanton, and E. R. Breaker, chief engineer, San Antonio. (August 8, p. 253.)

## Railway Financial News.

**SOUTHWESTERN TRACTION.**—This company, which operates a line from Belton, Tex., northeast to Temple, has amended its charter in Texas, increasing the capital stock from \$165,000 to \$3,500,000, and authorizing extensions as follows. From Temple north to Waco, and from Temple or Belton, south to Austin, in all about 100 miles. Surveys have been made for the extensions, and most of the right of way has been secured. It is expected that construction work will be started soon. In addition the company contemplates extending the line from Austin south to San Antonio. A. F. Bentley, is president, and W. G. Bentley, secretary, both of Temple. (July 25, p. 170.)

**UWHARIE & PEE DEE VALLEY.**—We are told that application has been made for incorporation in North Carolina to build from Winston-Salem in Forsyth county, N. C., southeast through Guilford, Randolph, Montgomery, Richmond, Scotland, Robeson and Columbus counties, to a point in Brunswick county, probably at Southport, about 200 miles. The incorporators include E. A. Lackey, J. L. Hayward, Thomas Baldwin and O. C. Armstrong. C. A. Armstrong, Troy, is also an incorporator.

**WINNEMUCCA NORTHERN.**—An officer writes that location survey has been completed to Homedale, Idaho, on Snake river, 240 miles from Winnemucca, which is 40 miles from Boise, Idaho. The plans call for building from Winnemucca, Nev., northeast via Paradise, Quinn river, and McDermott, to Jordan Valley, Oregon, thence to Boise, Idaho, in all 280 miles. The maximum grades will be 1 per cent., and maximum curvature 10 deg. About 75 miles of the work will be heavy. The estimated cost of construction is \$7,500,000. The company will probably be ready to start construction work in November. Thomas Nelson, president, San Francisco, Cal.; H. H. Sheldon, chief engineer, Winnemucca, Nev. (February 14, p. 314.)

### RAILWAY STRUCTURES.

**DENVER, COLO.**—Architects are engaged on the working plans for the remodeling of the Denver union station, which will practically create a new station. Approximately \$2,000,000 is to be expended on the work by the Union Depot Terminal Company.

**NEW CASTLE, PA.**—The Pittsburgh & Lake Erie is building a two-story brick freight house in New Castle, to cost \$25,000. Work on the foundations has been completed.

**PEARL, ILL.**—The Chicago & Alton has completed the installation of the final span of its new bridge across the Illinois river at this point. The contract was let to the Wisconsin Bridge Company.

**PROPOSED TUNNEL UNDER THE ENGLISH CHANNEL.**—The agitation in favor of the tunnel under the English Channel would seem to be based upon arguments which are often out of proportion to the interests involved and almost always short-sighted. To answer the military objections by pointing to England's friendliness with France is entirely to forget how short-lived have been the groupings of European Powers during the nineteenth century. In 1848 England's attitude to France was very doubtful; in 1851, the Exhibition year, relations were good; in 1854 the French and English fought side by side in the Crimea, and in the 'sixties the whole country was enthusiastic about raising volunteers to prevent French attack. In 1870, after the Franco-Prussian War, the relations improved, to be again upset about the time of Fashoda, when England was within an ace of war. Hence the arguments based upon French friendship are of little value. Again, arguments based upon the increased communication which England should have with France are not strong. The tunnel would be almost entirely occupied by passenger trains and a little high-class parcels traffic, and the additional number of people who would travel to France would certainly not be so great as to modify seriously the British attitude towards the Continent, even if such a modification was entirely desirable. To the argument that it would be difficult to defend, less importance attaches than formerly, though history gives innumerable instances of the unforeseen in war time and the failure of carefully pre-arranged plans at the last moment. Apart from this, the old arguments against the tunnel would appear to be as strong as ever, while no new ones have been brought forward in favor of it which are at all convincing.

**BANGOR & AROOSTOOK.**—James Brown, of Brown Brothers & Co., New York, has been elected chairman of the executive committee of the Bangor & Aroostook.

**CHICAGO, ROCK ISLAND & PACIFIC.**—On October 27 the New York *Evening Post* published a statement to the effect that Phelps, Dodge & Co., New York, who own the El Paso & Southwestern and who acquired in 1910 a minority interest in the common stock of the Rock Island Company, which is the holding company for the Chicago, Rock Island & Pacific, have now bought a controlling interest in the preferred stock of the Rock Island. Control of the Rock Island preferred carries with it control of the entire voting machinery of the Rock Island system. Phelps, Dodge & Company denied that they had obtained absolute control of the Rock Island; but on the other hand it is not denied that they have made large further purchases of Rock Island securities since 1910, and the *Post* on Tuesday reiterated the fact that today the control of the Rock Island system is in the hands of Phelps, Dodge & Company, and that E. G. Reid is the member of the Moore-Reid syndicate who has sold his holdings.

T. M. Schumacher was on Wednesday elected chairman of the executive committee of the Rock Island Company. For sketch of Mr. Schumacher's life see our *Railway Officers'* column for this issue.

**HOCKING VALLEY.**—The Public Utilities Commission of Ohio has authorized the Hocking Valley to issue \$4,000,000 one-year 5 per cent. notes of November 1, 1913, to refund an equal amount of notes maturing November 1, 1913. The notes are to be sold at not less than 99.

**PENNSYLVANIA RAILROAD.**—The following notice has been officially given out at the president's office:

The finance committee and board of directors are considering the creation of a general mortgage as a basis for the company's financing for many years to come. Under this mortgage it is contemplated to issue bonds in such amounts from time to time as may be required to provide necessary additions, betterments and improvements to its railroads, equipment, property and facilities; the funds that may be necessary to meet maturing obligations, and for such other corporate purposes as may now or hereafter be duly authorized by law. The aggregate amount of bonds that may be issued shall not at any time exceed the outstanding capital stock. When approved by the directors, the whole question will be laid before the stockholders for their consideration at the annual meeting in March next. The company has no expenditures that require immediate financing, but desires to announce the contemplated preparations for the necessary refunding and capital expenditures in 1914, 1915, and later years, which it will be able to meet through the issue of either capital stock, consolidated (first) mortgage bonds, the new general mortgage bonds, or such other form of financing as will produce the best results for the company and meet the monetary conditions prevailing at the time of issue.

**ST. LOUIS & SAN FRANCISCO.**—In addition to authorizing the receivers to issue \$10,000,000 receivers' certificates, as mentioned in this column last week, Judge Sanborn has authorized the receivers to pay the semi-annual interest, due November 1, on the \$69,000,000 general lien 5 per cent. bonds, which interest amounts to about \$1,725,000. The interest payment is to be made from funds on hand.

**SUGARLAND.**—The state of Texas has lost its case against the Sugarland Railroad company for penalties amounting to \$5,000 and a mandatory injunction to compel the road to rebuild a short branch which had been torn up and which the railroad claims would have cost \$40,000 to construct and \$10,000 annually to maintain, with practically no revenue. The case was filed in July, 1911, shortly before the company had extended its line from a point three miles from Arcola Junction to a point eighteen miles south of the connecting point of the International & Great Northern and the Santa Fe, leaving a spur 3½ miles long from the point of divergence of the extension to Arcola Junction. Permission was granted by the railroad commission to tear up the spur, but later the order was revoked, and the company was ordered to rebuild the track.



# ANNUAL REPORTS.

## THE ATCHISON, TOPEKA & SANTA FE RAILWAY SYSTEM.

SEPTEMBER 23, 1913.

**To the Stockholders:**

Your Directors submit the following report for the fiscal year July 1, 1912, to June 30, 1913, inclusive.  
The Lines comprising the Atchison System, the operations of which are embraced in the following statements, are as follows:

	June 30, 1913.	June 30, 1912.
Atchison, Topeka & Santa Fe Railway.....	8,237.55 miles.	8,200.86 miles.
Rio Grande & El Paso Railroad.....	20.21 "	20.21 "
Gulf, Colorado & Santa Fe Railway.....	1,595.77 "	1,596.06 "
Pecos & Northern Texas Railway.....	481.79 "	478.67 "
Pecos River Railroad.....	54.24 "	54.24 "
Southern Kansas Railway of Texas.....	124.92 "	124.92 "
Texas & Gulf Railway.....	125.49 "	125.80 "
Gulf & Interstate Railway of Texas.....	71.33 "	71.97 "
Concho, San Saba & Llano Valley Railroad.....	60.15 "	60.15 "
	<u>10,771.45 "</u>	<u>10,732.88 "</u>

Increase during the year 38.57 miles.  
The average mileage operated during the fiscal year ending June 30, 1913, was 10,750.31 miles, being an increase of 122.39 miles as compared with the average mileage operated during the preceding fiscal year.  
In addition to lines covered by this report there were completed on June 30, 1913, 155.20 miles of additional line, of which 119.42 miles were ready for operation on July 1, 1913.  
The Company also controls, through ownership of stocks and bonds, other lines aggregating 63.58 miles, and is interested jointly with other companies in 624.56 miles.  
For detailed statement of present mileage and of changes in mileage since last Annual Report, see pages 42 to 46.

**INCOME STATEMENT.**

The following is a summary of the transactions of the System for the years ending June 30, 1912 and 1913:

	1912.	1913.
Operating Revenues.....	\$107,752,359.91	\$116,896,251.98
Operating Expenses.....	71,273,202.97	77,642,534.73
Net Operating Revenue.....	\$36,479,156.94	\$39,253,717.25
Taxes.....	4,206,453.85	4,662,152.38
Operating Income.....	\$32,272,703.09	\$34,591,564.87
Other Income.....	2,569,968.22	2,515,623.96
Gross Corporate Income.....	\$34,842,671.31	\$37,107,188.83
Rentals and Other Charges.....	1,521,570.56	1,128,129.10
Interest on Bonds, including accrued interest on Adjustment Bonds.....	\$33,321,100.75	\$35,979,059.73
	13,660,859.50	13,825,325.40
Net Corporate Income (representing amount available for dividends and surplus and for necessary but unproductive or only partially productive expenditures).....	\$19,660,241.25	\$22,153,734.33

From the net corporate income for the year the following sums have been deducted:

<b>DIVIDENDS ON PREFERRED STOCK—</b>	
No. 29 (2½%) paid Feb. 1, 1913.....	\$2,854,345.00
No. 30 (2½%) paid Aug. 1, 1913.....	2,854,345.00
	\$5,708,690.00
<b>DIVIDENDS ON COMMON STOCK—</b>	
No. 29 (1¼%) paid Sept. 2, 1912.....	\$2,559,097.50
No. 30, (1¼%) paid Dec. 2, 1912.....	2,586,052.50
No. 31 (1¼%) paid Mar. 1, 1913.....	2,613,562.50
No. 32 (1¼%) paid June 2, 1913.....	2,640,067.50
	10,398,780.00

Appropriation for Fuel Reserve Fund.....	461,105.11
Appropriated for Additions and Betterments.....	5,574,433.63
California-Arizona Lines Bonds Sinking Fund.....	10,725.59
	\$22,153,734.33

Surplus to credit of Profit and Loss June 30, 1912.....	\$20,470,115.99
Additions to Profit and Loss Account (Sundry Adjustments applicable to prior years).....	99,684.82
Surplus to credit of Profit and Loss June 30, 1913.....	\$20,569,800.81

Income from sources other than earnings from operation consisted of interest on cash in banks and sums collected as interest and dividends upon bonds and stocks of companies, the operations of which are not included in the System accounts.

During the fiscal year the sum of \$200,000 in cash was received as the net proceeds of sales of land embraced in the Santa Fe Pacific Land Grant, but this was directly written off the book value of Railroads, Franchises and Other Property, and the transaction does not appear in the Income Account.

**CAPITAL EXPENDITURES AND REDUCTION OF BOOK VALUES.**

The total charges to Capital Account, as shown by the General Balance Sheet, page 26, at June 30, 1913, aggregated \$640,263,756.10 as compared with \$621,869,989.29 at June 30, 1912, an increase during the year of \$18,393,766.81, which analyzes as follows:

Construction and acquisition of new mileage, including the acquisition of bonds and stocks of other railway and terminal companies:	
Belt Ry. of Chicago.....	\$ 240,000.00
California, Arizona & Santa Fe Ry.....	1,500.00
Concho, San Saba & Llano Valley R. R.....	11,982.64
Denver Union Terminal Ry.....	5,000.00
Dodge City & Cimarron Valley Ry.....	1,266,870.83
Eastern Ry. of New Mexico.....	1,036,987.19
Grand Canyon Ry.....	36,806.36
Gulf, Beaumont & Kansas City Ry.....	99,094.90
Minkler Southern Ry.....	72,888.58
Union Passenger Depot Co. of Galveston.....	95,000.00
Western Arizona Ry.....	26,842.33
	\$2,892,972.83

<b>Additions and Betterments—System Lines:</b>	
Right of Way, Station Grounds, and Real Estate.....	\$ 294,013.21
Widening Cuts and Fills, including Protection of Banks.....	519,480.20
Grade Reductions and Changes of Line.....	240,467.85
Bridges, Trestles and Culverts.....	506,956.83
Ballast, including cost of spreading and putting under track.....	678,463.24
Increased Weight of Rail.....	238,946.06
Frogs, Switches, Track Fastenings, and Appurtenances.....	693,252.17
Additional Main Tracks.....	3,143,627.06
Sidings and Spur Tracks.....	720,910.62
Terminal Yards.....	377,957.83
Track Elevation, Elimination of Grade Crossings, and Improvements of Over and Under Grade Crossings.....	34,249.62
Interlocking, Block and Other Signal Apparatus.....	343,806.78
Telegraph and Telephone Lines.....	8,896.61
Buildings, Shops, Dock and Wharf Property.....	1,494,374.47
Shop Machinery and Tools.....	250,067.84
Additional Equipment.....	9,502,718.09
Betterments to Equipment.....	50,351.13
Other Additions and Betterments.....	134,532.58
	\$19,233,072.19

<b>Fuel Lands and Other Properties:</b>	
Fuel Lands.....	\$ 402,531.50
Ice Plant, Belen.....	3,685.22
Santa Barbara Tie & Pole Co.....	23,208.98
Real Estate held for future use.....	966,537.35
Miscellaneous Items.....	82,200.72
	\$ 1,478,163.77

<b>Other Investments</b> .....	664,209.85
<b>Total Charges</b> .....	\$24,268,418.44

<b>Reduction of Book Values:</b>	
Gulf, Beaumont & Kansas City Ry.....	\$ 99,000.00
Gulf, Colorado & Santa Fe Ry.....	38,649.59
Santa Fe Pacific R. R.—Land Sales.....	200,000.00
Sunset Ry.....	30,069.77
Ice Plant, San Bernardino.....	50,119.76
Fuel Lands.....	1,811,531.50
Tie and Timber Lands.....	36,613.30
Reserve for Accrued Depreciation.....	3,608,667.91
	\$ 5,874,651.83

Net Increase in Capital Account during the year..... \$18,393,766.81

The item of \$9,502,718.09 for "Additional Equipment" analyzes as follows:—

118 Locomotives.....	\$ 3,105,306.39
52 Passenger-Train Cars.....	637,572.25
5,658 Freight-Train Cars.....	6,437,040.76
470 Miscellaneous Cars.....	239,709.15
	\$10,419,628.55

Less—Value of equipment retired during the year as follows:

49 Locomotives.....	\$217,288.27
15 Passenger-Train Cars.....	52,215.48
1,384 Freight-Train Cars.....	592,617.83
16 Miscellaneous Cars.....	11,423.44
1 Steam Boat.....	43,365.44
	916,910.46

\$9,502,718.09

**MAINTENANCE OF EQUIPMENT.**

The following statement shows the sums charged to Operating Expenses for Maintenance of Equipment during each year since July 1, 1896:

Year Ending June 30.	Average Operated Mileage.	Total Expenditure.	Expenditure Per Mile.
1897.....	6,443.81	\$3,443,884.82	\$ 534.45
1898.....	6,936.02	4,659,277.99	671.73
1899.....	7,032.62	4,810,795.64	684.07
1900.....	7,341.34	5,267,832.46	717.56
1901.....	7,807.31	6,257,456.57	801.49
1902.....	7,855.38	7,884,951.25	1,002.22
1903.....	7,965.13	8,510,543.09	1,068.48
1904.....	8,179.59	10,006,135.41	1,223.31
1905.....	8,305.40	10,914,864.47	1,314.19
1906.....	8,433.99	10,720,940.43	1,271.65
1907.....	9,273.15	11,779,846.64	1,270.32
1908.....	9,415.01	14,246,621.44	1,513.18
1909.....	9,794.86	13,903,897.37	1,419.51
1910.....	9,916.33	15,560,047.44	1,569.13
1911.....	10,350.13	16,686,145.45	1,612.17
1912.....	10,627.92	16,521,231.41	1,554.51
1913.....	10,750.31	19,415,224.63	1,806.02

For the year ending June 30, 1913, maintenance charges, including renewals and depreciation, averaged as follows:

Per locomotive.....	\$4,770.08
Per locomotive mile.....	1.172
Per passenger car, including mail and express.....	1,283.40
Per passenger car mile.....	.0141
Per freight car.....	114.92
Per freight car mile.....	.0104

The foregoing average maintenance charges include a proportion of unlocated expenditures for Maintenance of Equipment charged to Superintendence, Shop Machinery and Tools, Injuries to Persons, Stationery and Printing, Other Expenses, and Maintaining Joint Equipment at Terminals. Beer and refrigerator cars are not taken into consideration in arriving at the foregoing averages, such cars being operated by the Santa Fe Refrigerator Despatch Company, which bears the expense of their maintenance. A statement of the locomotives in service and of their tractive power will be found on page 41.

**MAINTENANCE OF WAY AND STRUCTURES.**

The following statement shows the sums charged to Operating Expenses for Maintenance of Way and Structures during each year since July 1, 1896:

Year Ending June 30.	Average Operated Mileage.	Total Expenditure.	Expenditure Per Mile.
1897	6,443.81	\$6,282,923.15	\$ 975.03
1898	6,936.02	8,281,397.88	1,193.97
1899	7,032.62	7,672,107.62	1,090.93
1900	7,341.34	6,354,372.10	865.56
1901	7,807.31	6,433,840.36	824.08
1902	7,855.38	6,141,466.39	781.82
1903	7,965.13	9,304,892.04	1,168.20
1904	8,179.59	9,170,234.07	1,121.11
1905	8,305.40	11,385,418.33	1,370.85
1906	8,433.99	12,475,407.97	1,479.18
1907	9,273.15	15,286,062.66	1,648.42
1908	9,415.01	14,120,828.02	1,499.82
1909	9,794.86	12,884,406.81	1,315.43
1910	9,916.33	17,807,136.20	1,795.74
1911	10,350.13	16,059,786.90	1,551.65
1912	10,627.92	16,076,833.75	1,512.70
1913	10,750.31	18,054,413.03	1,679.43

**COMPARISON OF OPERATING RESULTS.**

The following is a statement of revenues and expenses of the System for the fiscal year ending June 30, 1913, in comparison with the previous year:

	Year Ending June 30, 1913.	Year Ending June 30, 1912.	Increase.
<b>OPERATING REVENUES:</b>			
Freight	\$ 78,190,923.18	\$ 71,529,574.67	\$ 6,661,348.51
Passenger	29,425,922.44	27,453,525.41	1,972,397.03
Mail, Express and Miscellaneous	9,279,406.36	8,769,259.83	510,146.53
<b>Total Operating Revenues</b>	<b>\$116,896,251.98</b>	<b>\$107,752,359.91</b>	<b>\$9,143,892.07</b>
<b>OPERATING EXPENSES:</b>			
Maintenance of Way and Structures	\$ 18,054,413.03	\$ 16,076,833.75	\$ 1,977,579.28
Maintenance of Equipment	19,415,224.63	16,521,231.41	2,893,993.22
Traffic Expenses	2,455,784.69	2,416,746.46	39,038.23
Transportation Expenses	35,135,649.15	33,733,667.06	1,401,982.09
General Expenses	2,581,463.23	2,524,724.29	56,738.94
<b>Total Operating Expenses</b>	<b>\$ 77,642,534.73</b>	<b>\$ 71,273,202.97</b>	<b>\$ 6,369,331.76</b>
<b>Net Operating Revenue</b>	<b>\$ 39,253,717.25</b>	<b>\$ 36,479,156.94</b>	<b>\$ 2,774,560.31</b>
Ratio of Operating Expenses to Operating Revenues	66.42	66.15	.27

The following averages are deduced from tables set forth on pages 36 and 39.  
 The average tons of freight (revenue and company) per loaded car mile increased from 18.52 to 19.12, or 3.24 per cent.  
 The average tons of freight (revenue and company) carried per freight-train mile (freight, mixed and company-supply) increased from 399.94 to 425.41, or 6.37 per cent.  
 The average freight revenue per revenue freight-train mile increased from \$3.26 to \$3.48, or 6.75 per cent.  
 The average passenger revenue per revenue passenger-train mile increased from \$1.18 to \$1.24, or 5.08 per cent.  
 The average passenger-train revenue per revenue passenger-train mile increased from \$1.47 to \$1.54, or 4.76 per cent.  
 The tons of freight carried one mile (revenue and company) increased 803,362,748, or 9.03 per cent., while miles run by freight cars (loaded and empty) in freight, mixed and company-supply trains increased 37,223,924, or 5.49 per cent., and the mileage of such trains increased 557,001, or 2.50 per cent.  
 The number of passengers carried one mile increased 50,692,714, or 3.98 per cent., while miles run by passenger cars in passenger and mixed trains increased 3,691,588, or 2.68 per cent., and the mileage of such trains increased 428,699, or 1.84 per cent.

The following is a consolidated statement of the business of the System for each fiscal year during the period since January 1, 1896:

Fiscal Year Ending June 30.	Average Miles Operated.	Gross Revenues, Including Income from Other Sources.	Expenses, Including Taxes, Rentals and Other Charges.	Interest on Bonds.	Net Corporate Income.
1897 (18 mos.)	6,443.81	\$44,532,628.99	\$36,038,455.30	\$8,440,387.91	\$ 53,785.78
1898	6,936.02	39,396,126.41	30,513,553.17	7,045,988.30	1,836,584.94
1899	7,032.62	40,762,933.47	29,332,964.11	7,241,972.00	4,187,997.36
1900	7,341.34	46,498,899.04	29,414,427.56	7,345,166.50	9,739,304.98
1901	7,807.31	54,807,379.78	34,502,039.87	7,830,810.83	12,474,529.08
1902	7,855.38	60,275,944.33	36,272,432.45	8,438,985.00	15,564,526.88
1903	7,965.13	63,668,390.99	40,635,576.48	9,134,485.24	13,898,329.27
1904	8,179.59	69,419,975.41	44,641,434.10	9,418,770.00	15,359,771.31
1905	8,305.40	69,189,739.65	47,835,883.50	9,611,510.09	11,742,346.06
1906	8,433.99	79,390,749.05	51,035,355.71	10,622,184.22	17,733,209.12
1907	9,273.15	94,436,574.68	61,779,916.16	11,487,934.70	21,168,723.82
1908	9,415.01	91,289,770.61	65,031,582.67	12,579,301.77	13,678,886.17
1909	9,794.86	95,424,091.89	61,458,019.13	13,548,081.93	20,417,990.83
1910	9,916.33	107,543,250.16	75,133,314.54	11,984,151.36	20,425,784.26
1911	10,350.13	109,772,481.69	75,689,094.83	12,712,319.31	21,371,067.55
1912	10,627.92	110,322,328.13	77,001,227.38	13,660,859.50	19,660,241.25
1913	10,750.31	119,411,875.94	83,432,816.21	13,825,325.40	22,153,734.33

The following statement shows the gross operating revenues of the System (exclusive of income from other sources) per mile of road operated for each fiscal year since July 1, 1896:

Year ending June 30.	Gross Operating Revenues.	Average per Mile of Road.
1897	\$ 30,621,230.10	\$ 4,752.04
1898	39,214,099.24	5,653.69
1899	40,513,498.63	5,760.80
1900	46,232,078.23	6,297.49
1901	54,474,822.61	6,977.41
1902	59,135,085.53	7,527.97
1903	62,350,397.28	7,827.92
1904	68,171,200.18	8,334.31
1905	68,375,837.25	8,252.70

Year ending June 30.	Gross Operating Revenues.	Average per Mile of Road.
1906	78,044,347.25	9,253.55
1907	93,683,406.91	10,102.65
1908	90,617,796.38	9,624.82
1909	94,265,716.87	9,624.00
1910	104,993,194.67	10,587.91
1911	107,565,115.62	10,392.63
1912	107,752,359.91	10,138.61
1913	116,896,251.98	10,873.75

The following statement shows the development of the freight and passenger revenues of the System since July 1, 1896:

Year ending June 30.	Freight Revenue.	Passenger Revenue.
1897	\$22,067,686.77	\$ 5,574,288.31
1898	28,588,716.76	7,347,361.59
1899	29,492,586.65	8,126,141.85
1900	33,729,332.83	9,334,661.57
1901	39,052,557.43	11,678,017.25
1902	41,815,607.05	13,439,384.57
1903	44,622,438.71	13,469,985.78
1904	47,762,653.23	15,433,773.63
1905	47,408,982.36	16,045,380.27
1906	54,598,902.82	18,013,988.56
1907	65,500,309.42	21,171,629.08
1908	61,848,638.51	21,643,427.49
1909	64,212,638.10	22,734,505.32
1910	71,194,055.59	25,437,181.98
1911	71,787,200.89	27,204,867.66
1912	71,529,574.67	27,453,525.41
1913	78,190,923.18	29,425,922.44

**PROPERTY INVESTMENT AND RATE OF RETURN.**

The growth of the business of your Company indicated by the foregoing three statements, and also the increased efficiency suggested by the averages immediately preceding those statements, are due principally to the very large expenditures (over \$270,000,000) which have been made in the extension and improvements of the property since January 1, 1896. In order to make such expenditures your Company has raised, since 1896 over \$217,000,000 of "new money" by the sale of bonds which are now outstanding or which (in the case of many of the convertible bonds issued) are represented by common stock now outstanding. The following statement shows, for each year, the amount of investment, the amount of net income applicable to bond interest, dividends, improvement of property and strengthening of credit, and the rate of return which such net income represents on the amount of the investment.

Year Ending June 30th.	Property Investment.*	Income Applicable to Bond Interest, Dividends, Improvement of Property and Strengthening of Credit.	Per Cent. of Property Investment.
1896 (6 months)	\$372,104,262.77	\$ 2,432,870.06	.65
1897	387,957,477.68	6,070,364.45	1.57
1898	392,169,842.02	8,871,947.26	2.26
1899	399,527,444.30	11,409,315.36	2.86
1900	407,187,811.22	17,064,850.91	4.19
1901	419,541,440.17	21,196,714.38	5.05
1902	439,911,035.33	23,921,018.14	5.44
1903	454,290,057.89	23,032,814.51	5.07
1904	466,273,139.34	24,778,541.31	5.31
1905	473,020,998.79	21,353,856.15	4.51
1906	496,782,342.35	28,355,393.34	5.71
1907	519,004,129.48	32,724,274.07	6.31
1908	541,727,328.96	25,633,510.34	4.73
1909	548,251,270.97	33,523,437.28	6.11
1910	579,793,768.23	32,387,712.39	5.58
1911	609,287,764.18	34,102,511.86	5.59
1912	621,869,989.29	33,321,100.75	5.36
1913	640,263,756.10	36,086,013.36	5.64
<b>Annual Average</b>	<b>\$487,164,658.84</b>	<b>\$23,786,642.62</b>	<b>4.88</b>

\*The amounts above shown as "Property Investment" do not include anything for necessary working capital such as materials and supplies and cash. Ordinarily such necessary working capital considerably exceeds \$35,000,000. In the years 1901 to 1908 the "Property Investment" was reduced by "writing off" sums aggregating \$21,066,685.78, which sums are excluded from the "Property Investment" as above stated.

In the years 1910 to 1913 sums aggregating \$16,077,421.48, consisting of depreciation of equipment accrued pursuant to the ruling of the Interstate Commerce Commission, have been deducted from the amount shown as "Property Investment" and are excluded in the above statement.

†The "Income" shown above is determined after allowing for adjustments made through profit and loss.

The last statement emphasizes the striking fact that the earnings on the entire investment are now not much in excess of five per cent. per annum and continue on that basis notwithstanding the increase in efficiency and the increase in the volume of traffic. It may be explained that the ability of your Company under such circumstances to pay six per cent. on the common stock is due to the fact that it pays an average of substantially less than five per cent. on its bonded debt, and, indeed, much of the bonded debt was created when money could be borrowed at or near four per cent.

The very moderate return which is realized upon the investment, especially when considered in connection with the increased rates which must now be paid for new capital, indicates that in order to preserve and strengthen the credit of even the most successful railroad companies, to the end that they may be able to develop and improve their property so as to promote the public safety and the public convenience, the Government ought to increase, rather than to reduce still further, the rates for transportation and ought to be exceedingly slow about increasing still further the costs of operation. It is very clear from the foregoing statement that the mere growth of business and the mere increase in efficiency will not afford adequate protection against further reduction in rates for transportation and further increases in costs, especially in view of the increasing rates demanded for the use of money.

**CAPITAL STOCK AND FUNDED DEBT.**

The outstanding Capital Stock (deducting stock in treasury) on June 30, 1912, consisted of:

Common	\$170,129,500.00
Preferred	114,173,730.00
<b>Total</b>	<b>\$284,303,230.00</b>

Issued during the year:

Common Stock issued in exchange for Convertible Bonds retired .....	20,707,000.00
---	---------------

Capital Stock outstanding June 30, 1913:

Common .....	\$190,836,500.00
Preferred .....	114,173,730.00
	<u>\$305,010,230.00</u>

The outstanding Funded Debt of the System (deducting bonds in the treasury) amounted on June 30, 1912, to..... \$342,645,015.00  
 The following changes in the Funded Debt occurred during the year:

Obligations Purchased or Retired:

Serial Debenture 4% Bonds,	
Series K .....	\$ 785,000.00
Series L .....	1,903,000.00
Convertible 4% Bonds .....	14,241,000.00
Convertible 5% Bonds .....	6,466,000.00
California-Arizona Lines First and Refund- ing Mortgage 4 1/2% Bonds .....	4,866.50
Miscellaneous Divisional Bonds .....	99,000.00
	<u>23,498,866.50</u>

Total System Funded Debt outstanding June 30, 1913..... \$319,146,148.50

Interest charges for the year ending June 30, 1914, will be approximately \$12,900,000, or an average monthly charge of about \$1,075,000. In making this approximation, exchanges of Convertible Bonds for Common Stock made since June 30, 1913, aggregating \$3,574,000, are considered.

**TREASURY.**

Neither this Company nor any of its auxiliaries has any notes or bills outstanding.

The Company held in its treasury on June 30, 1913, \$30,096,205.59 cash, and had available \$3,780,000 General Mortgage Bonds, including bonds not yet certified by the Trustee. The Company also has in the treasury unpledged a large amount of stocks and bonds of other companies, of which part are carried in the balance sheet as Investments and part are included under Railroads, Franchises and Other Property.

**FUEL RESERVE FUND.**

The fund has been increased during the year by earnings derived from sundry fuel properties, and decreased by certain payments for fuel properties, as follows:

Amount to credit of Fund June 30, 1912.....	\$1,827,272.58
Added during the year .....	461,105.11
	<u>\$2,288,377.69</u>

Deduct sums paid for fuel properties..... 561,531.50

In Fund June 30, 1913..... \$1,726,846.19

**DODGE CITY AND CIMARRON VALLEY RAILWAY.**

This line, which was under construction at the date of last annual report, extending from Dodge City, Kansas, in a southwesterly direction to Elkhart, Kansas, a distance of about 120 miles, was completed during the year. The operation of the new line by your company as a part of its System began on July 1, 1913, under lease of that date.

**MINKLER SOUTHERN RAILWAY COMPANY.**

This company was formed to construct certain new lines through rich orchard country in the San Joaquin Valley of California. Of the projected lines about 40 miles, between Wauko, Cutler and Exeter, are now under construction.

**WEST TEXAS CONSTRUCTION.**

The lines in West Texas, the construction of which was commenced in 1909, and reference to which was made in the annual reports for that and subsequent years, are completed, with the exception of the extension of the Coleman-Lubbock line from Lubbock, Texas, to Texico, New Mexico. This extension, 89 miles in length, is about three-quarters completed and will probably be fully opened for business about January 1, 1914.

**VERDE VALLEY RAILWAY.**

During the year this line, extending from Cedar Glade to Clarkdale, Arizona, a distance of about 38 miles, has been completed. The line is operated by your Company under lease and was opened for traffic February 1, 1913.

**NORTHWESTERN PACIFIC RAILROAD.**

The construction of the line of this company (whose capital stock is owned, one-half by your Company and one-half by the Southern Pacific Company, between Willetts and Shively, California, referred to in the last annual report, has been actively prosecuted throughout the year, 24.95 miles having been completed, leaving only 41.20 miles still to be constructed. The construction of this line involves very heavy work through a mountainous country, so that progress is necessarily slow; however, a large amount of grading for the remaining mileage has already been done and the work will be pushed to completion as rapidly as conditions permit.

**UNION PASSENGER STATION, KANSAS CITY.**

A new passenger station and extensive passenger facilities at Kansas City are nearing completion, and will probably be opened for use before the expiration of this fiscal year; the terminal is to be used by all the roads entering Kansas City and is one of the most complete passenger terminals in the country as well as one of the most expensive, owing to local topography and other conditions. The use of the new facilities will be an enormous convenience to the public and will entail a large expense on the part of the railroads. On the other hand the conditions at the old station had become intolerable to both parties.

**THE BELT RAILWAY OF CHICAGO.**

During the year your Company acquired an interest in the Belt Railway of Chicago, the capital stock of which was increased so as to permit of ownership in equal parts by twelve of the railway companies entering Chicago, all of which have paid in cash at par for the stock acquired by them. The Belt Company leases from the Chicago & Western Indiana Railroad Company what is known as the Belt Division of that company's property, comprising about 21 miles of main line and branches, and also the freight distributing or clearing yard and facilities formerly owned by the Chicago Union Transfer Railway Company, which was acquired by the Chicago & Western Indiana Railroad Company as of September 2, 1912. The lease in question is dated November 1, 1912, and runs until September 1, 1982, with option of purchase at the expiration of that period. The enlargement of this company and the revival of the freight clearing yard will tend to facilitate materially the interchange of freight traffic between all railways entering Chicago.

**ADDITIONAL MAIN TRACK MILEAGE.**

The mileage of second track in operation on June 30, 1913, was 898.12 miles as compared with 801.90 miles at the close of the preceding fiscal year, being an increase of 96.42 miles.

**SECOND TRACK WORK IN PROGRESS.**

**MISSOURI DIVISION:**

Floyd to Sibley, Mo..... 3.63 miles.

**LINE WEST OF ALBUQUERQUE:**

Rito to Laguna, N. M..... 9.16 "  
 Cactus to Flagstaff, Ariz..... 43.32 "  
 Ash Fork to Pan, Ariz..... 22.55 "  
 Summit to Keenbrook, Cal..... 10.69 "

Total..... 89.35 "

It is expected that all the second track work in progress will be completed by January 1st next, making a total on that date of 987.67 miles of second track in operation.

**RECENT DECISIONS IN STATE RATE CASES.**

Pursuant to the recent decision of the United States Supreme Court in the Missouri Rate Cases, your Company put into effect in that State the 2-cent passenger fare as well as the reduced freight rates, but the tariffs covering this rates have been filed under protest. In Oklahoma, where the order of the United States Circuit Court for the Western District of that State, restraining the enforcement of the 2-cent provision of the State Constitution, had not been seriously opposed pending the outcome of the other State rate cases before the United States Supreme Court, the 2-cent fare was re-established July 3, 1913. The case, however, by mutual consent is being held open for a reasonable period to enable your Company and other interested carriers to re-construct their case, as far as possible within the limitations laid down in the Supreme Court decisions in the Minnesota and other State rate cases.

The compilation of statistics indicating the confiscatory nature of these low rates is now in progress and upon its completion these cases in which your Company is interested will, it is expected, be carried to a final adjudication.

**TAXES.**

In the last annual report attention was called to the steadily increasing burden of taxation, and a table was submitted showing that the percentage of increase in taxation during the five years ending June 30, 1912, was slightly over 68 per cent. There has been no diminution of this burden during the fiscal year covered by this report, but on the contrary, the increase has continued, the taxes for the year aggregating \$4,662,152.38. This sum is equivalent to 11.8 per cent. of the operating income for the year and exceeds the taxes of the preceding year to the extent of 10.8 per cent.

During the year the Company suffered the loss of Mr. Geo. T. Nicholson, Vice-President, who died in Los Angeles, March 30, 1913. Mr. Nicholson had been in the service of the Company almost continuously for thirty years. He was a man of ripe judgment and fine executive ability, and moreover was of an engaging personality and much beloved by all of his associates.

Your Directors again take pleasure in recording their appreciation of the loyal and efficient service rendered by officers and employees.

EDWARD F. RIPLEY,  
*President.*

**ANNUAL REPORT OF THE MINNEAPOLIS, ST. PAUL & SAULT STE. MARIE RAILWAY CO.**

Including Chicago Division (Wisconsin Central)

**FOR THE FISCAL YEAR ENDED JUNE 30, 1913.**

Herewith is submitted report for the Fiscal Year ended June 30, 1913. The Gross Earnings, Expenses, Fixed Charges and Surplus Income are shown in condensed form as follows:

	Soo Line	Chicago Division	Soo Line System
Gross Earnings .....	\$21,410,672.03	\$10,893,990.47	\$32,304,662.50
Operating expenses .....	12,096,214.80	7,208,299.24	19,304,514.04
Net earnings .....	\$9,314,457.23	\$3,685,691.23	\$13,000,148.46
Income from other sources....	871,051.19	49,038.70	920,089.89
Total income .....	\$10,185,508.42	\$3,734,729.93	\$13,920,238.35
Fixed charges, taxes, etc.....	4,658,092.94	2,641,379.47	7,299,472.41
Surplus income .....	\$5,527,415.48	\$1,093,350.46	\$6,620,765.94

The substantial increase in the Company's Gross Earnings, while partially due to the unusual grain crop of 1912, reflects also the growth and general

prosperity of the Northwest, including the Canadian Northwest and the settlement of the territory adjacent to the Company's lines. Three years since, the Soo Line built a line into the so-called Cuyuna Iron Range, located in Aitkin and Crow Wing counties, Minnesota. A dock was built at Superior, Wisconsin, to handle ore from this range to Lake vessels. The first shipments were made in 1912 and aggregated about three hundred thousand tons. This season's shipments will be approximately one million tons and next season, unless the iron industry is seriously disturbed, three million tons are expected. It is doubtful if any Iron Range has shown a more rapid development.

The Company has in course of construction at this time, eighty-five miles of additional main track extending from Ambrose, N. D., west, which will be completed in time to move this season's crop. Additional mileage at this time is not contemplated and will not be until improved financial conditions prevail, or the attitude of the public as expressed through its various avenues of political activities assures more reasonable treatment of transportation companies.

Construction of freight terminals in the city of Chicago is progressing

ANNUAL REPORT OF THE MINNEAPOLIS, ST. PAUL & SAULT STE. MARIE RAILWAY CO.

Including Chicago Division (Wisconsin Central)

satisfactorily and will be completed by January 1, 1914. Funds for the construction of this terminal were fully provided at the initiation of the project. The completed property will be equal, if not superior, to any freight terminal of its size in Chicago.

During the year, at a cost of \$240,000.00, this Company acquired twenty-four hundred shares of the Belt Railway Company of Chicago, thus placing it on a parity with the twelve other lines interested in that Company. The Belt Railway Company operates extensive switching lines in the city of Chicago. The advantages of thus securing direct connection with the numerous industries adjacent to the Belt Company's tracks are obvious.

The consistent growth of the Company's business and the more rigid exactions of the public for improved facilities and safety devices require from year to year larger expenditures for additions and betterments to the property, expansion of its shop facilities and liberal additions to its

equipment. Over one million two hundred thousand dollars were expended during the year for additions and betterments. Extensive additions at the principal shops, located at Shoreham, are in progress.

By means of an Equipment Trust arrangement aggregating \$3,806,657.19, issued January 1st, 1913, the equipment was increased to the extent of 25 Locomotives, 49 Steel Passenger Cars of various classes, 1,700 Freight Cars, 300 Ore Cars, 20 Caboose Cars and 200 Ballast Cars. In accordance with the Company's well established policy, its property and equipment has been maintained to yield its full working efficiency.

General conditions which obtain throughout the Northwest at this time seem to assure a satisfactory tonnage during the current year.

Respectfully submitted,  
E. PENNINGTON,  
President.

GENERAL BALANCE SHEET, JUNE 30, 1913.

ASSETS.		LIABILITIES.	
<i>Property Investment:</i>		<i>Capital Stock:</i>	
Road .....	\$92,213,209.26	Common .....	\$25,206,800.00
Equipment .....	20,519,163.23	Preferred .....	12,603,400.00
	\$112,732,372.49	Total .....	\$37,810,200.00
Less Reserve for Accrued Depreciation.....	1,592,246.03	<i>Mortgage, Bonded and Secured Debt:</i>	
Total .....	\$111,140,126.46	First Mortgage M. & P. Ry. Co. 4% Bonds.	\$286,000.00
<i>Securities of Proprietary, Affiliated and Controlled Companies:</i>		First Mortgage M. S. S. M. & Atl. Ry. Co.	
Wisconsin Central Ry. Co. Stock.....	\$3,658,337.09	4% Bonds .....	8,136,000.00
St. Paul Union Depot Co. Stock.....	103,600.00	First Consolidated Mortgage M. St. P. &	
Minnesota Transfer Ry. Co. Stock.....	7,000.00	S. S. M. Ry. Co. 4% Bonds.....	54,916,000.00
Sault Ste. Marie Bridge Co. Stock.....	500.00	Second Mortgage M. St. P. & S. S. M. Ry.	
Sault Ste. Marie U. D. Co. Stock.....	50,590.56	Co. 4% Bonds .....	3,500,000.00
Central Terminal Ry. Co. Stock.....	900,000.00	Equipment Trust Obligations .....	6,695,000.00
Belt Ry. Co. of Chicago Capital Stock.....	240,000.00	Total .....	73,533,000.00
Central Terminal Ry. Co. Bonds.....	139,500.00	<i>Working Liabilities:</i>	
Minnesota Transfer Ry. Co. Bonds.....	59,000.00	Traffic and Car Service Balances due to	
Total .....	5,158,527.65	Other Companies .....	\$186,527.18
<i>Other Investments:</i>		Audited Vouchers & Wages Unpaid.....	3,863,275.20
Miscellaneous Investments:		Miscellaneous Accounts Payable.....	264,330.07
Tri-State Land Company Stock.....	\$25,000.00	Matured Interest and Dividends Unpaid....	1,308,197.00
Western Express Company Stock.....	50,000.00	Total .....	5,622,329.45
Coeur d'Alene & Pend d'Oreille. Ry. Co.		<i>Accrued Liabilities Not Due:</i>	
5% Bonds .....	25,200.00	Unmatured Interest .....	\$139,140.00
W. C. Ry. Co. Equipment Contract.....	630,129.60	Taxes Accrued .....	609,366.05
Miscellaneous Stock .....	151.00	Total .....	748,506.05
Total .....	730,480.60	<i>Deferred Credit Items:</i>	
<i>Working Assets:</i>		Operating Reserve .....	\$213,314.34
Cash .....	\$3,357,524.54	Other Deferred Credit Items.....	90,664.86
Securities in Treasury:		Total .....	303,979.20
First Consolidated Mortgage M. St. P. &		Profit and Loss .....	14,468,468.22
S. S. M. Ry. Co. 4% Bonds.....	2,691,000.00	Grand Total .....	
Pillsbury-Washburn Flour Milling Co.,		\$132,486,482.92	
Ltd., 5% Bonds .....	4,700.00	<i>Contingent Liabilities:</i>	
Village of Alexandria Bonds.....	4,000.00	As joint maker with the Central Terminal Railway Com-	
Traffic and Car Service Balances due from		pany of Illinois of Bonds secured by mortgage on prop-	
other companies .....	413,041.89	erty of the Central Terminal Railway Company.....	\$ 6,000,000.00
Net Balances due from Agents and Con-		4% Leased Line Certificates of the Minneapolis, St. Paul	
ductors .....	1,215,871.40	& Sault Ste. Marie Railway Company, issued in exchange	
Misc. Accounts & Bills Receivable.....	889,481.04	for Preferred Stock of the Wisconsin Central Railway	
Material and Supplies .....	3,399,180.09	Company, held therefor .....	\$ 11,169,000.00
Total .....	11,974,798.96		
<i>Accrued Income Not Due:</i>			
Unmatured Dividends .....	\$111,690.00		
Unmatured Interest .....	12,261.11		
Total .....	123,951.11		
<i>Deferred Debit Items:</i>			
Central Terminal Ry. Co.....	\$248,341.07		
Tri-State Land Co.....	1,530,338.77		
Land Sales (Deferred Payments).....	120,000.00		
Special Deposits for Equipment, etc.....	908,934.49		
Other Deferred Debit Items.....	51,043.83		
Working Funds .....	127,544.78		
Unextinguished Discount on Securities.....	372,395.20		
Total .....	3,358,598.14		
Grand Total .....	\$132,486,482.92		

OPERATING REVENUES AND EXPENSES.

<i>Revenue from Transportation:</i>	
Freight Revenue .....	\$15,330,648.06
Passenger Revenue .....	4,564,256.51
Excess Baggage Revenue .....	47,611.80
Mail Revenue .....	370,353.10
Express Revenue .....	370,762.14
Other Passenger Train Revenue .....	2,244.76
Switching Revenue .....	57,327.57
Special Service Train Revenue.....	8,400.49
Miscellaneous Transportation Revenue.....	18,484.53
<b>Total Revenue from Transportation.....</b>	<b>\$20,770,088.96</b>
<i>Revenue from Operations Other than Transportation:</i>	
Station and Train Privileges.....	\$16,926.53
Parcel Room Receipts .....	1,355.95
Storage, Freight .....	1,427.30
Storage, Baggage .....	1,840.02
Car Service .....	33,018.96
Telegraph Service .....	89,698.59
Rents of Buildings and Other Property.....	39,073.20
Miscellaneous .....	4,658.03
<b>Total Revenue from Operations Other than Transportation .....</b>	<b>\$ 187,998.58</b>
Joint Facilities Revenue .....	10,466.81
<b>Total Operating Revenues .....</b>	<b>\$20,968,554.35</b>
<i>Operating Expenses:</i>	
Maintenance of Way and Structures.....	\$2,292,992.97
Maintenance of Equipment.....	2,603,668.64
Traffic Expenses .....	357,518.43
Transportation Expenses .....	6,090,410.90
General Expenses .....	458,418.33
<b>Total Operating Expenses .....</b>	<b>\$11,803,009.27</b>
<b>Net Operating Revenue .....</b>	<b>\$ 9,165,545.08</b>
<b>INCOME ACCOUNT, FISCAL YEAR ENDED JUNE 30, 1913.</b>	
<b>Net Operating Revenue .....</b>	<b>\$ 9,165,545.08</b>
<i>Outside Operations:</i>	
Revenues .....	\$ 442,117.68
Expenses .....	293,205.53
<b>Net Revenue from Outside Operations.....</b>	<b>148,912.15</b>
<b>Total Net Revenue .....</b>	<b>\$ 9,314,457.23</b>
Taxes Accrued .....	1,298,967.59
<b>Operating Income .....</b>	<b>\$ 8,015,489.64</b>
<i>Other Income:</i>	
Dividends on Stock Owned.....	\$ 458,621.00
Hire of Equipment .....	148,335.07
Interest and Discount .....	150,133.58
Rents Receivable .....	69,127.37
Interest on W. C. Ry. Equipment Contract..	34,732.51
Interest on Bonds Owned.....	10,101.66
<b>Total Other Income.....</b>	<b>871,051.19</b>
<b>Gross Corporate Income.....</b>	<b>\$ 8,886,540.83</b>
<i>Deductions from Gross Corporate Income:</i>	
Interest on Bonds.....	\$2,506,280.00
Interest on W. C. Ry. Leased Line Certificates	445,824.00
Interest on Equipment Notes.....	244,095.00
Rental of Terminals .....	162,926.35
<b>Total Deductions from Gross Corporate Income.....</b>	<b>3,359,125.35</b>
<b>Net Corporate Income .....</b>	<b>\$ 5,527,415.48</b>

PROFIT AND LOSS ACCOUNT TO JUNE 30, 1913.

By Balance June 30, 1912.....	\$11,707,346.06
Net Corporate Income for the Year Ended June 30, 1913...	5,527,415.48
	<b>\$17,234,761.54</b>
<i>Deductions for Year:</i>	
7 per cent Dividend on Preferred Stock.....	\$ 882,238.00
7 per cent Dividend on Common Stock.....	1,764,476.00
Extinguishment of Discount on Bonds and Car Trust Notes .....	20,374.34
Equipment Depreciation Prior to July 1, 1907..	25,752.91
Items Transferred to General Balance Sheet Accounts; Premiums on Stock, Discount on Bonds and Charges to Operating Reserve, per I. C. C. Classifications.....	73,452.07
	<b>2,766,293.32</b>
<b>Balance Credit June 30, 1913.....</b>	<b>\$14,468,468.22</b>

TRAFFIC AND MILEAGE STATISTICS, AS PER INTERSTATE COMMERCE COMMISSION CLASSIFICATION.

	1913.	1912.
	Passengers, Tonnage, Rates and Revenue.	Passengers, Tonnage, Rates and Revenue.
<i>Passenger Traffic:</i>		
Number of Passengers Carried Earning Revenue .....	2,248,502	1,930,486
Number of Passengers Carried One Mile .....	198,188,238	168,920,156
Number of Passengers Carried One Mile per Mile of Road.....	67,978	61,635
Average Distance Carried, Miles.....	88.14	87.50
Total Passenger Revenue .....	\$4,564,256.51	\$3,872,487.90
Average Amount Received from Each Passenger .....	\$2.02991	\$2.00597
Average Receipts per Passenger per Mile .....	\$.02303	\$.02292
Total Passenger Service Train Revenue .....	\$5,355,228.31	\$4,592,504.63
Passenger Service Train Revenue per Mile of Road .....	\$1,836.84	\$1,675.71
Passenger Service Train Revenue per Train Mile .....	\$1.44163	\$1.31638
<i>Freight Traffic:</i>		
Number of Tons Carried of Freight Earning Revenue .....	7,761,407	6,200,764
Number of Tons Carried One Mile .....	2,072,932,191	1,652,831,716
Number of Tons Carried One Mile per Mile of Road.....	711,014	603,085
Average Distance Haul of One Ton, Miles .....	267.08	266.55
Total Freight Revenue .....	\$15,330,648.06	\$11,934,791.52
Average Amount Received for Each Ton of Freight .....	\$1.97524	\$1.92473
Average Receipts per Ton per Mile..	\$.00740	\$.00722
Freight Revenue per Mile of Road..	\$5,258.40	\$4,354.76
Freight Revenue per Train Mile....	\$3.11885	\$2.85583
<i>Total Traffic:</i>		
Operating Revenues .....	\$20,968,554.35	\$16,770,699.79
Operating Revenues per Mile of Road .....	\$7,192.19	\$6,119.28
Operating Revenues per Train Mile..	\$2,528.30	\$2,295.96
Operating Expenses .....	\$11,803,009.27	\$9,342,443.87
Operating Expenses per Mile of Road .....	\$4,048.42	\$3,408.86
Operating Expenses per Train Mile..	\$1,423.16	\$1,279.01
Net Operating Revenue.....	\$9,165,545.08	\$7,428,255.92
Net Operating Revenue per Mile of Road .....	\$3,143.77	\$2,710.42

# Railway Age Gazette

PUBLISHED EVERY FRIDAY AND DAILY EIGHT TIMES IN JUNE, BY THE  
SIMMONS-BOARDMAN PUBLISHING COMPANY,  
WOOLWORTH BUILDING, NEW YORK.

CHICAGO: Transportation Bldg. CLEVELAND: Citizens' Bldg.  
LONDON: Queen Anne's Chambers, Westminster.

E. A. SIMMONS, *President.*  
L. B. SHERMAN, *Vice-President.* HENRY LEE, *Sec'y & Treas.*  
The address of the company is the address of the officers.

EDITORS.

SAMUEL O. DURN, *Editor.*

ROY V. WRIGHT, <i>Managing Editor.</i>	H. H. SIMMONS	E. S. FAUST
W. E. HOOPER	H. F. LANE	F. W. KRAEGER
B. B. ADAMS	E. A. AVERILL	A. D. CLOUD
E. T. HOWSON	R. E. THAYER	GEORGE L. FOWLER
	A. C. LOUDON	

Subscriptions, including 52 regular weekly issues and special daily editions published from time to time in New York, or in places other than New York, payable in advance and postage free:

United States and Mexico.....	\$5.00
Canada .....	8.00
Foreign Countries (excepting daily editions).....	8.00
Single Copies .....	15 cents each

Engineering and Maintenance of Way Edition and four Maintenance of Way Convention Daily issues, North America, \$1.00; foreign, \$2.00.

Entered at the Post Office at New York, N. Y., as mail matter of the second class.

WE GUARANTEE, that of this issue 8,200 copies were printed; that of those 8,200 copies, 6,000 were mailed to regular paid subscribers and 248 were provided for counter and news' companies sales; that the total copies printed this year to date were 388,209—an average of 8,627 copies a week.

VOLUME 55. NOVEMBER 7, 1913. NUMBER 19.

## CONTENTS

EDITORIAL:

Editorial Notes .....	851
The American Railway Association and Railway Accidents.....	852
Juggling Railway Statistics.....	853
*Chicago, Burlington & Quincy.....	854, 893

LETTERS TO THE EDITOR:

A Missionary's View of Railroads; by Charles E. Bradt.....	855
Need for Co-operation Between Railways Regarding Operation....	856

MISCELLANEOUS:

The Supply Department of the Railway; by George G. Yeomans.....	857
Train Accidents in September.....	860
*Construction of Clinchfield Extension.....	861
*Powerful Articulated Electric Locomotives.....	868
National Association of Railway Commissioners.....	869
Legislation Affecting the Time and Manner of Payment of Railroad Wages; by Arthur B. Jones.....	871
The Need for Higher Wages; by B. A. Worthington.....	872
*Locomotive Fuel Economy on the Frisco; by Robert Collett.....	874
Foreign Railway Notes .....	859, 869, 878

GENERAL NEWS SECTION..... 878

\*Illustrated.

notice on the management demanding that the surprise tests be abandoned, unless with each one there shall be the preliminary torpedo signal. Being thus warned by the explosion that they are about to be "surprised," their peace of mind will, no doubt, be greatly promoted; and the improved (?) scheme thus should redound to their physical and mental health and result in an all-around prosperity. As the brotherhoods depend largely on Congress to help them get whatever they want out of their employer, it should be suggested to them that this proposition be at once sent to Washington. Only, it should be changed around; instead of suggesting that the tests be abandoned, direct pressure should be brought to bear for the prompt introduction of the torpedoes. And they should be used not only occasionally, but should be provided regularly at all signals, everywhere, every day. Then the runner's peace of mind could be almost perfect; he would not need to think at all. But, putting aside levity, the serious thing indicated by such an incident as this is that the local engineers' organizations are too much dominated by their shortsighted members. Every level-headed, reflecting engineman recognizes the value and the reasonableness of surprise checking. Where a vote is passed which takes the opposite view, there is need for a lot of education. And should not the superintendent make it his duty to see that this educating is done? Objections, of any kind, which may be elicited by surprise checking should receive his immediate attention. If the surprise checking has been in any degree unreasonable he has the additional duty of educating himself.

OF all the industries the railroads, which are second only to agriculture in magnitude and second to none in the range of requirements for trained men, obtain the least benefit from the colleges and universities of the country. It might be expected that the mechanical department at least, would attract a large number of engineering graduates each year, but actually it absorbs surprisingly few, and of those starting, a very small percentage remain after the first year or two. The results of an effort to discover where the fault lies and how it can be corrected, so far as this department is concerned, are being published in the columns of the *Railway Age Gazette, Mechanical Edition*. In the current issue are letters from Alex. C. Humphreys, president of Stevens Institute of Technology, and D. C. Buell, chief of the Bureau of Education of the Union Pacific, Illinois Central and Central of Georgia, which discuss the subject at considerable length and point out wherein mistakes are frequently made, both by the railways and the universities. Dr. Humphreys suggests a more carefully designed special apprenticeship course for engineering graduates which would supplement the previous college training to the best advantage. He believes that such a course would not require over two years' time. As part of this course he recommends the holding of evening classes for, say, three nights a week, which should be conducted by competent men trained in theory and practice, and would result in more quickly giving an understanding and an appreciation of the practical application of engineering science to the requirements of the railroad. He states that unless these engineering graduates are to receive special treatment as apprentices, which will shorten the term of their apprenticeship, they might better follow some other line of study in the school of experience. Mr. Buell in his letter claims that comparatively few of the engineering graduates who enter railroad service have any definite conception of what railroad work really is, or any goal in the field toward which they are aiming. He suggests that more intelligent and practical vocational guidance be given the members of the graduating classes in the universities and technical schools. In this way a man graduating from one of these schools and entering railroad work would know exactly what opportunities exist and have some idea of the difficulties in the path he has elected to follow. Such guidance, if given by men who thoroughly under-

IN the early days of traveling auditors an unsophisticated station agent, perfectly honest, and having in the drawer all the cash needed to square his accounts, but with books not in the best of condition, was considerably embarrassed by the unexpected visit of the new inquisitor, "Why," said he, "I am not only willing, but anxious to please you, and to satisfy the company; if you had only let me know that you were coming I would have had everything ready." The innocence of this old-time station agent is matched, in this twentieth century, down in Louisiana, by some enginemen of the Southern Pacific, who are entirely satisfied with surprise checking if only they can have a torpedo signal to give them notice of each test! Both the engineers' and the firemen's organizations have recently served

stand the subject, would no doubt tend to prevent many of the losses which now take place during the first year or two of the special apprentice courses.

#### THE AMERICAN RAILWAY ASSOCIATION AND RAILWAY ACCIDENTS.

THE railway accident record of this country is not growing worse. It is growing better. The railroad managements are not responsible for the large number of trespassers killed on their properties. Excluding trespassers, the total number of persons killed in the five years 1903-1907, inclusive, according to the statistics of the Interstate Commerce Commission, was 25,083. In the second half of this decade, being the years 1908-1912, inclusive, the total fatalities were 22,817, an absolute reduction of 12½ per cent. less. The mileage of the railways, the number of their employees, the number of trains run, the passenger and freight traffic handled, and the number of persons who used the highways which cross their lines at grade, steadily increased; yet in the first 5-year period the average number killed annually was 5,216, while in the second period the average number killed annually was only 4,563.

While the number of accidents has been reduced, both relatively and absolutely, the need for dealing vigorously and effectively with the accident situation has been accentuated. Public attention has been concentrated on the subject more and more; and unless it is dealt with more vigorously and effectively by the railways action seems almost certain to be taken by the lawmakers and public administrative officials, which will be of very questionable expediency. There are two things which, it would seem, the railway managements should do; first, adopt more comprehensive and thorough-going methods to reduce accidents; second, co-operate with lawmakers and public administrative officials whose intentions are good in framing and securing the enforcement of such legislation as the conditions may warrant.

At its meeting in New York in May, 1912, the American Railway Association adopted resolutions setting forth that its members fully appreciated the need for increased efforts by this organization, by the railways individually and by their employees, for the reduction of accidents, but at the same time deprecating, hasty and ill-advised legislation. Clearly, the American Railway Association, being the principal organization of railways dealing with operating problems, is the proper body to deal with the subject of accidents. Since the resolutions mentioned were adopted, a number of very bad wrecks have occurred, and there has been an almost unprecedented storm of public agitation regarding this general matter. The Interstate Commerce Commission has investigated some of these wrecks, and, it is understood, will, when Congress meets in regular session in December, make recommendations for legislation. The American Railway Association will meet in Chicago on November 19. Will it be prepared then, after the passage of a year and a half since its resolutions were adopted, to take some constructive step?

It will be extremely unfortunate for the Association and for the railways if it is not. It will be unfortunate for the association, because there is a large and growing element among its members who criticize it with increasing outspokenness and vigor on the ground that while it seldom does the things that it ought not to do, it often does not do the things that it ought to do. And the criticism is just. Its course too often recalls the sower in the parable who went forth to sow, and cast his seed on shallow and stony ground where the birds speedily came and picked it all up. It has had the opportunity for years to deal aggressively and constructively with all large operating problems. But the negative forces in it have so often been more potent than the positive forces that its record of achievement has fallen very far short of what it ought to be. If it ever had opportunity to do a constructive work which imperatively demanded to be done it has that opportunity now. Somebody is going to deal more effectively with the accident problem. If

it is not the American Railway Association it may be some other railway organization. Already other organizations have sprung up to do work which seemed properly to belong to the American Railway Association but which that organization would not undertake or which, when it had undertaken it, it bungled. If the great, pressing problems are to continue to be left thus to be dealt with by other organizations, how long can the American Railway Association hope to maintain its prestige and to continue to receive the loyal and active support of its membership?

While the American Railway Association will suffer if it does not meet the issue presented by the accident problem squarely and deal with it manfully and courageously, the railways will suffer still more—unless, indeed, some other organization steps in and does what that association ought to do. The lawmakers, the commissions and the public are looking to the railways, and rightfully looking to them, to do something more about accidents than they have been doing. If the railways do not do so, the lawmakers, the commissions and the public will surely undertake the task themselves.

Doubtless many persons question in their own minds what the American Railway Association or any other railway organization can do. The things that ought to be done by the railways are well known. First, they ought to make the best practicable use of such financial resources as they have to put their structures and equipment in the best practicable condition, so as to reduce to a minimum accidents due to physical causes. But main causes of accidents other than those to trespassers are disobedience or mistakes of employees; and the remedies are better supervision and better discipline, including more care, more perseverance and the use of more scientific methods in selecting, training, promoting, checking up and disciplining employees. The various railway associations have devoted much investigation and discussion to the matter of improving structures and equipment in the interest of safety. Where is the railway organization that is devoting thorough and constructive investigation and discussion to the best methods of improving the personnel of the railways—not merely to getting better raw material, but also to working that raw material into a finished product that will do its intended work as it should do it?

It may be said that this is a matter which ought to be left to the managements of the individual systems. But is there so much to be gained by investigation, the interchange of views and the adoption of recommended practice regarding structures and equipment, and little or nothing to be gained by investigation, discussion and the adoption of recommended practice regarding the selection, training, promotion and disciplining of employees? The employees are opposing the adoption of "surprise" signal checking where it is not used, and seeking its abolition where it is used. Is the matter of the color of the signal lights that should be used one which can profitably be investigated and acted on by a railway association, but the matter of "surprise" checking one which cannot be profitably investigated and acted on by a railway association? The American Railway Association is revising its Code of Train Rules. Is the matter of the rules that ought to be adopted one which is suitable for investigation and action, and the matter of the means which should be used to ascertain whether the rules are being obeyed and to secure obedience to them one which is not suitable for investigation and action by any railway organization?

When the government regulates railways it applies uniform regulations to them. Why cannot the railways adopt and apply to themselves regulations of all the kinds that are needed to promote safety which shall be uniform, at least, for railways which are similarly situated and thus to a large extent make government regulation obviously unnecessary? As not only accidents due to physical conditions, but accidents due to conditions as respects personnel, reflect discredit and bring criticism and punitive regulation, not only on the roads on which the accidents occur, but also on all other roads, why should not all

the roads concertedly study and take some form of action regarding the conditions in respect to personnel that cause accidents, as well as in regard to the physical conditions that cause them?

It would seem that the American Railway Association ought to take up the whole problem of accidents and deal with it courageously and perseveringly on broad, constructive lines; or that it should delegate this work to some other organization, giving it full power to act; or that it should wash its hands of the entire matter and let some other organization be formed that will deal with it effectively. If the American Railway Association itself is to handle the problem, some fundamental changes in its organization and methods must be made. It must develop means for securing more constructive investigation and discussion; and, what is of far greater importance, it must develop means for causing its members to do the things that they ought to do. It is of little moment for eminent railway officers to meet in solemn session for three hours twice a year to hear and adopt committee reports unless the action taken at these meetings is to be courageous and constructive and unless that taken by the railways collectively is to serve as a guide for the railways individually. As past experience has shown that many members of the association will not live up to its recommendations unless practically compelled to do so, has not the time about come when the association should adopt some means for compulsion? Or will the railways, instead of adopting some means for compelling each other to do the things which they ought to do, leave all of the coercing to be done by the government?

**JUGGLING RAILWAY STATISTICS.**

THE unreliability of statistics, especially when they are made, not by those who are trying to ascertain facts, but by those who are trying to prove what they wish to be believed to be facts, has caused various reflections to be cast on statisticians. For example, it has been said that figures do not lie, but that liars often do figure. Also, liars have been classified into liars, damned liars and statisticians. We are always led to ruminate on the wisdom of these sayings when we survey the statistics regarding railways which are worked up and peddled by a certain class of persons.

For example, there is Clifford Thorne, chairman of the Railroad Commission of Iowa, who recently has made up certain statistics to show how much of the return now paid to railway capital could be saved under government ownership. He told the National Association of Railway Commissioners in Washington last week that the par value of the securities of American railroads outstanding in the hands of the public on June 30, 1912, was \$15,286,101,957; but he estimated the market value of these securities in October, 1913, at only \$13,969,173,383, and he therefore assumed that the government could acquire the railways at this figure. He assumed also that the government would have to pay only 3 per cent. interest on bonds issued by it to raise the money to acquire the railways. He then presented the following table, which shows how he arrived at his conclusion that an immense sum could be saved under government ownership:

Net stock outstanding June 30, 1912.....	\$5,843,446,355	
Dividends paid in fiscal year 1912.....		\$460,432,752
Market value of stocks, October, 1913.....	\$5,554,604,806	
Interest at 3 per cent.....		166,638,144
Excess in dividends.....		\$293,794,608
Net bonds outstanding June 30, 1912.....	\$9,442,655,592	
Interest paid (estimated on 1911 basis).....		\$422,782,629
Market value of bonds, October, 1913.....	\$8,414,567,577	
Interest at 3 per cent.....		252,437,027
Excess in interest.....		\$170,345,602
Recapitulation—		
Saving in stock dividends.....		\$293,794,608
Saving in bond interest.....		170,345,602
Total savings.....		\$464,140,210

If, as Mr. Thorne figures, a saving of \$464,140,210 in the cost of railway capital could be made under government ownership,

the *Railway Age Gazette* would declare for that policy right now. For as Mr. Thorne shows, the wages of labor could then be increased \$100,000,000 a year, and at the same time enormous sums could be used to improve railway properties and in mitigation of rates. But unfortunately Mr. Thorne, as usual, had not the slightest notion of what he was talking about. He calculated the total interest and dividends of the railways at over \$883,000,000. Now, the fact is that even the total net operating income of the railways never in any year amounted to anywhere near that sum. The net operating income in the year ended June 30, 1912, of all roads earning over \$100,000 gross—in other words, what they had left after paying operating expenses and taxes—was only \$755,869,000; and in the fiscal year ended June 30, 1911, the net operating revenue of all roads was only \$773,866,000. These are the statistics of the Interstate Commerce Commission. In other words, the total interest and dividends of the railways as given by Chairman Thorne, exceed their net operating income by over \$100,000,000. Mr. Thorne's calculation as to what the government could save is based upon the assumption that it could acquire the railways for \$13,900,000,000, on which it would have to pay interest at 3 per cent. But, after the government had deducted \$464,000,000 the estimated saving from the total net operating income in 1911, it would have had left only \$309,725,712, which, at 3 per cent., would have paid a return on only \$10,314,000,000, or \$3,800,000,000 less than Mr. Thorne's own estimate as to what the government would have to pay for the railroads!

Clearly, the great railway economist and railway regulator from Iowa has stubbed his statistical toe. As he never would be able to find out where, we will tell him. While he places the total interest and dividends paid at \$883,000,000, the fact is, that the interest paid in 1911 on bonds outstanding in the hands of the public was only \$380,411,667, and the dividends paid on stock outstanding in the hands of the public were only \$291,497,164, a total return to capital of only \$671,908,831, or \$211,316,550 less than Mr. Thorne's figure. Of course, a little matter of \$211,000,000 is of no consequence to a man so rich in statistics as Mr. Thorne, but railway investors missed the money terribly! The reader may be interested to know how Chairman Thorne could have fallen into the mistake of computing the total interest and dividends paid as in excess of the total net operating income by over \$100,000,000, and in excess of the interest and dividends actually paid out by over \$200,000,000. His error consisted in using the figures for gross interest and dividends, where he should have used those for net interest and dividends. The duplication in the securities of American railways caused by the intercorporate ownership of bonds and stocks causes a similar duplication in interest and dividend payments; and it is only by eliminating these duplications, amounting in 1911 to over \$200,000,000 a year, that we can arrive at the interest and dividends actually paid.

After having found Mr. Thorne blundering thus about the interest and dividends paid we might naturally expect to find him falling into other errors; and in this we are not disappointed. His assumption that the government could acquire the railways for \$13,900,000,000 is based on an estimate made by him of the market value of the securities in October, 1913. Even assuming his estimate to be correct—a very dangerous assumption—it is well known that railway securities stood in October, 1913, at one of the lowest levels that they have ever reached; and it is just as irrational to base an estimate of the value of railways on extremely low market prices as on extremely high market prices. Furthermore, nowhere near all railway securities changed hands in October, 1913, a sufficient demonstration that those who did not sell at that time would not take for their securities the prices then current. Again, Mr. Thorne's estimate that the government would have to pay only 3 per cent. interest is wide of the mark. Neither the government of the United States nor that of any other country on earth could now issue 3 per cent. bonds at par purely as an



investment security. Any government would be fortunate, in the present state of the money market, if it could market them on materially less than a 4 per cent. basis. It is likely, in case the United States government acquired the railways, that it would have to pay for them at least \$16,000,000,000, and that its interest rate would not be less than 3½ per cent. Even on that basis the interest payments of the government would be over \$100,000,000 less than the interest and dividend payments of the railways. But that would not go far in enabling it to raise wages, reduce rates and make improvements. Merely a 5 per cent. reduction in rates and a 5 per cent. increase in operating expenses would reduce railway net earnings by almost \$236,000,000 a year; and that there would be an increase of much more than 5 per cent. in operating expenses under government ownership, the experience of the world clearly indicates.

Mr. Thorne is not the only public man who juggles recklessly with railway statistics. In a speech published in the *Congressional Record* for October 28, page 483, Senator LaFollette of Wisconsin said: "In 1905 more than 10,000 passengers and more than 48,000 employees were killed on the railroads of the United States." The senator always has been adept at manufacturing railway statistics, but in this case he surpassed his earlier brilliant performances. The "Statistics of Railways in the United States" of the Interstate Commerce Commission for 1905, page 122, state that the total number of railway passengers killed in 1905 was 537, and the total number of railway employees killed, 3,361.

Is it any wonder, when United States senators and members of state railroad commissions put forth such statistics as those quoted from Messrs. LaFollette and Thorne that the public is misinformed regarding railway matters?

Another example of the dissemination of unfounded statistics regarding railways is afforded by an article entitled "The People or the Railroads," in *Hearst's Magazine* for November. In this article, it is said, "Stock and bonds, the railroad capitalization of the country, totals more than \$19,000,000,000. Of this, \$10,000,000,000 is 'water.'" A wide discrepancy will be noted between the capitalization figures given by Mr. Thorne and those given in *Hearst's*. The net capitalization of the railways of the United States in the fiscal year 1911, according to the

Interstate Commerce Commission, was \$15,008,770,570; and Mr. Thorne gives the commission as authority for the statement that in 1912 it was \$15,286,000,000. The investment in road and equipment which had been made up to June 30, 1911, as reported by the railways to the commission, was \$15,518,264,612, and up to June 30, 1912, was \$15,895,667,769. The statement that \$10,000,000,000 of the capitalization of the railways is water, is without a vestige of foundation. Not a scintilla of evidence ever has been cited in support of it, and not one ever can be. The facts are, as has been repeatedly pointed out, that there are some railways that are over-capitalized and others that are under-capitalized. But the evidence indicates, not that the railways as a whole are over-capitalized, but that as a whole they are under-capitalized.

How can it be expected, or even hoped, that the railways of the country will be fairly and intelligently dealt with by the public when public men and the press continue, either ignorantly or maliciously, to give currency to such false and misleading statements as those here referred to?

**CHICAGO, BURLINGTON & QUINCY.**

It has been the generally accepted theory in American railroad practice that if a company can make ample additions to its plant so as to keep that plant in shape to handle economically even the peak of the load, then an increase in gross business will be reflected by a more economical handling of each unit of the business and consequent increased net earnings. The Chicago, Burlington & Quincy showing in the fiscal year ended June 30, 1913, bears out this theory to a rather remarkable extent.

The Chicago, Burlington & Quincy operates 9,109 miles of road, a large proportion of it branch line mileage, carrying in 1913 956,000 ton miles per mile of road and 125,000 passenger miles per mile of road, and with its freight tonnage made up of about 31 per cent. bituminous coal, 20 per cent. products of agriculture, 16 per cent. manufactures and about 7 per cent. lumber. The Burlington is controlled jointly by the Great Northern, and the Northern Pacific, and is conservatively capitalized—if we mean by capitalization the issue of capital securities. On the other hand, the investment in the property is very large and the policy of further investment each year for a number of years

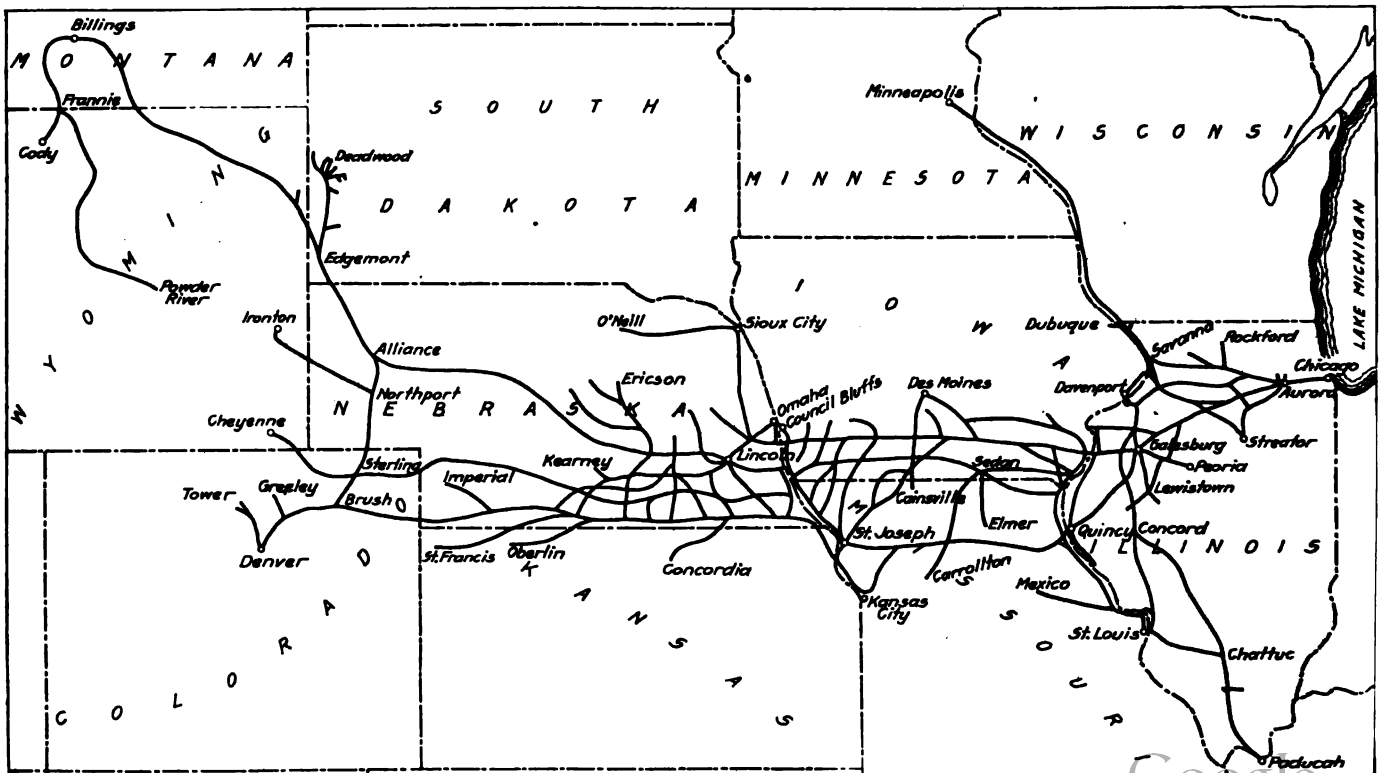

The Chicago, Burlington & Quincy.

past has been unusually liberal. It seems fair to assume, therefore, that the results obtained in 1913 are at least in part attributable to this policy.

Total operating revenues in 1913 were \$94,374,000, an increase of 8.7 per cent. over 1912, while total operating expenses amounted to \$62,843,000, an increase of but 3.6 per cent. In other words, the Burlington reduced its operating ratio from 70 in 1912 to 67 in 1913. After somewhat larger expenditures for maintenance—slightly less for maintenance of way and considerably more for maintenance of equipment—transportation expenses consumed \$29,998,000 in 1913 as against \$29,020,000 in 1912. This is an increase in transportation expenses of but 3.4 per cent., while the ton mileage handled increased 14.5 per cent. and the passenger mileage increased 3.5 per cent.

In 1912 the Burlington had an average train load in freight service of 484 tons and an average number of passenger miles per passenger train mile of 62. Multiplying the total passenger mileage by 7.3, the ratio of passenger miles per passenger train mile to ton miles per freight train mile, we get a composite unit of service which, for comparative purposes, will reflect an increase either in freight train or passenger train loading, and a reduction in cost handling either freight or passenger business. Transportation expenses per thousand of these units in 1912 was \$1.85. Applying the 1912 ratio to 1913 business, the transportation expenses per thousand units were \$1.75. When we take into consideration the showing that has been made by other roads in the 12 months under review, this reduction in transportation expenses per unit of business on the Burlington is remarkable.

The freight train load in 1913 was 438 tons, an increase of 10.5 per cent. With the previously mentioned increase of 14.5 per cent. in ton mileage there was an increase of but 4.1 per cent. in freight locomotive miles; and while passenger train mileage increased very slightly in conjunction with the increase of 3.5 per cent. in passenger miles handled, passenger locomotive miles actually decreased slightly, totaling 17,862,000 in 1913. This shows that while the Burlington did not reduce its passenger service, it succeeded in effecting economies even in this service by reducing the ratio of locomotive miles to train miles.

In 1913 a total of \$13,942,000 was spent by the C. B. & Q. for new lines, extensions, equipment, and additions and betterments. Of this amount \$8,441,000 was charged to capital account and \$3,898,000 to income. The total appropriation for betterments from income in 1913 was \$7,648,000, some of which, of course, was not spent in 1913. Since 1907 the Burlington has charged \$21,421,000 to income for additions to property.

The balance sheet of the Burlington is an exhibit of financial strength that can be equalled by few American railroads. Besides the \$21,421,000 surplus appropriated for additions to property just mentioned there are \$32,943,000 appropriated surplus invested in sinking funds, and \$3,750,000 not specifically invested; and in addition, a total profit and loss credit of \$91,039,000. Cash on hand at the beginning of 1913 amounted to \$8,734,000, and at the end of 1913 to \$4,815,000. There has been taken into the treasury a little over \$1,000,000 of securities issued or assumed, making the total at the end of 1913 \$11,859,000. The company had total working assets of \$33,871,000, with total working liabilities of \$11,469,000.

The following table shows the principal figures for operation in 1913 as compared with 1912:

	1913.	1912.
Average mileage operated.....	9,110	9,074
Freight revenue .....	\$64,063,856	\$57,740,419
Passenger revenue .....	21,895,691	21,083,419
Total operating revenues .....	94,374,486	86,723,068
Maint. of way and structures.....	12,535,863	13,541,030
Maint. of equipment.....	16,133,216	14,294,033
Traffic expenses .....	1,586,803	1,528,115
Transportation expenses .....	29,997,717	29,020,384
General expenses .....	2,589,293	2,263,387
Total operating expenses.....	62,842,891	60,646,949
Taxes .....	3,563,359	3,303,058
Operating income .....	27,840,545	22,650,360
Gross income .....	29,800,475	24,801,401
Net income .....	19,430,746	14,106,754
Dividends .....	8,867,128	8,867,128
Appropriations for betterments.....	7,647,743	3,944,216
Surplus .....	2,915,875	1,295,410

## Letters to the Editor.

### A MISSIONARY'S VIEW OF RAILROADS.

CHICAGO, October 29, 1913.

TO THE EDITOR OF THE RAILWAY AGE GAZETTE:

When traveling on one of our inland China trips, one of the missionaries said to us: "God builds the railroads." We had just remarked something about the help it would be in the work of extending the kingdom when the railroads should penetrate and ramify China. Our missionary friend voiced our convictions exactly, after having traveled for months, as we had, in jungles and desert places, over thousands of miles of backward and undeveloped lands in the old world. The value to human progress, the good done to mankind, by building railroads in those lands can be ascribed to no less a source than to God himself, as he leads his servants in the enterprise of railroad building.

What is true in the Orient is just as true in the Occident. We often hear people condemning the railroad corporations and operations. But how many of those people, who are ready to condemn, have ever analyzed the proposition: "What would we do? Where would we be as a country, or a people without the railroads?" While the railroads have shared and are sharing in the profits accruing from the progress they have mightily helped to produce, yet they are not beginning to get the "lion's share." The bulk of those profits is going and has gone to the people, most of whom have done comparatively little to accentuate those gains, except to draw their breath and their inheritance. This is one of the ways God, by his spirit, leads the world forward and cares for the human race, viz.: by leading large-brained, world-visioned men to plan and execute great programs in the commercial and industrial world, as well as in the world political and religious, scientific and social: and these men are all co-laborers together with God and master workmen as brothers in the same kingdom building business—missionaries, if you please. The Pere Marquette system of railway and lake steamer transportation is named after the missionary Marquette, the first white man to sleep where Chicago now stands, and who explored the Illinois river down to the Mississippi and the Mississippi down to the Arkansas.

Thus, the missionary of the church is intimately associated with the missionary of commerce; the two work hand-in-glove together for the upbuilding of the kingdom of God. Here is the testimony of one whose company illustrates what we are saying:

We go into a land stricken and barren and unprogressive, a land where women are hitched to the plows and men strive all day in the sun for a bare living, and we hand them the magic power of machinery. We make it possible for one man in an hour to do the day's work of three. We remove forever the haunting dread of famine; the joy of living takes the place of bitter struggle. The people are left emancipated to new happiness and education and real worship.

It is easy to find fault with all kinds of missionary work, and with all missionaries. They are pioneers; and they should not always be judged by the standards of settled and carefully adjusted society. They venture into untried and unknown fields, and if "wrecks" and "accidents" occur, occasionally, they are not to be set down always to criminal carelessness, or to wilful wickedness. The wonder is they do as well as they do. We have been traveling now for twenty-five years; during the past ten years we have averaged over 50,000 miles a year; perhaps we have traveled a million miles; most of this travel has been done on railway trains; and we have never been in a railway wreck.

We believe not only that God builds the railroads through his human agents, but that he also gives his spirit to the men who operate them, and thus enables them to further the welfare and progress of mankind, and to hasten the coming of the kingdom of God on the earth. These men, from the president of the road to the humblest engineer and switchman, from the train despatcher to the humblest telegraph operator and conductor, should have the prayers of Christian people the world around, and should be recognized as worthy servants of the most high God.

CHARLES E. BRADY,  
Central District Secretary, Board of Foreign Missions, Presbyterian Church.

## NEED FOR CO-OPERATION BETWEEN RAILWAYS REGARDING OPERATION.

CHICAGO, October 20, 1913.

TO THE EDITOR OF THE RAILWAY AGE GAZETTE:

One of the most remarkable things that confronts a student of the operation of American railways is the fact that there are no methods of operation which in their details are admittedly universal practice. It is amazing that after so many years of dealing with problems practically alike in their major features we cannot put our finger on one and say, "this is dealt with in this way."

While doubtless there is more or less difference in the exact form in which these problems present themselves on different roads, yet fundamentally the difference is one of form only, not of principle. And yet even where a similarity of principle is admitted the methods of treatment are widely dissimilar.

Contrast the conditions on the traffic side.

Years ago the circumstances under which traffic was secured caused frequent meetings of traffic men; and the associations which were then built up, and which were for a long time necessary for the partial protection of the revenue of the individual railways, have continued as clearing houses, through which officials of the traffic departments keep in touch with each other and with the developments which have gradually converted those departments from mere bureaus of solicitation into what they are today; and incidentally into a machine against which the operating men are well-nigh powerless in any disputed issue. But the operating man remains a more or less cheerful individualist. He gradually loses his cheerfulness as he climbs the ladder, but his individualism usually remains unimpaired.

It is only in recent years that this situation has become important. Within the business life of any man forty years old railways were comparatively small things, each of which was usually dominated by a relatively strong man; one who had not been trained in his business, but who, as his road grew from small to larger, had grown with it, meeting his problems as best he could, solving difficulties as he came to them, gradually building up precedents for his own road, and, by the force of his own ability, not only creating his own traditions, but also training subordinates to accept those precedents and defend those traditions.

As consolidations occurred and the size of properties increased, these men's methods usually were extended over the lines each acquired. In some lamentable cases they were not, and then there were two or more traditions struggling for the mastery. In few cases, however, was there any conscious reaching out to ascertain what other roads were doing or cordial willingness to absorb and adopt practices in lieu of those already in use. If a man was peculiarly effective, instead of other roads adapting his methods to their conditions, the man, himself, was acquired by some other road and set to work to apply his treatment in his new environment, while his successor in his old job upset what he found there.

The coming of officials to new railways, then, usually was followed by a season of turmoil when many of the familiar customs were overset and those of another road substituted; and this period of confusion usually lasted until the new displaced the old, or *vice versa*, depending upon the length of time which the newcomer felt they could devote to it, or in some cases upon the patience of the financial people under punishment.

The history of some of these revolutions, and subsequent reversions to type, if written, would be both interesting and improving, if only some one who knows enough about them would undertake to write their history.

But what has been the result? Briefly this:

The time is at hand—is indeed now here—when railway operation is to be scrutinized and its methods justified. Can it be done?

In the cases of many individual roads, undoubtedly, but in all—certainly not.

Regulation of carriers in the future will more and more deal with what we call operating functions, and that regulation will fall upon the road which is justified as well as upon the one whose failures make the regulation necessary.

Necessarily, all decisions must be reached by a series of compromises. It is, therefore, obvious that to bring about that reasonable uniformity in practice which is desirable, so-called standards, whether of work or of practice, should not be considered merely as bases of variation but as things which mean something, and for whose maintenance all are equally responsible.

It is axiomatic that methods on some roads which other roads would characterize as indefensible have caused such operating legislation as has already been passed. Unless some exchange exists for the interchange of information and some internal policing is done it is inevitable that one by one subjects will be reached and enactments made which will force a uniformity which may be unwholesome and certainly burdensome, while a wholesome uniformity is still within our power. This wholesome uniformity cannot, however, be brought about from the top only. It is the youngest men who are the most individualistic. The older ones have merely the inertia of long habit.

Is it not possible that the younger men can be encouraged to join and attend associations of those of their own class instead of being discouraged, as is often the case? Is it not fairer to them to do so? No one road contains all knowledge, even for its own conditions.

Should not associations of the junior classes work at something definite? Should there not be places where intelligent interchanges of opinion can take place? Should not their conclusions receive at least respectful attention, and intelligent discussion from senior associations, composed, as they are, of the more responsible officers?

But while this may be done to educate the present subordinate officers in the principle of the co-operation which the times will require them to exercise when they come to positions of greater responsibility, it is too late to wait for a new generation so trained.

There is but little time left to get together. Each year sees new regulations which produce costly uniformity, although enacted ostensibly to promote safety or equality of treatment.

Only one course may perhaps stop the steady progress of new legislation—roads which are deficient in their practices or lacking in their enforcement of proper practices must come to the standards of those more fortunately situated—and how shall they do this if no one shows them how?

If this be not done, it is certain that they will be brought to standards set by legislation, and when that happens all are served alike.

Surely the time has come when those agencies which have served their purpose in the past, but which have been shifted to the rear by the progress of events, must be re-established upon effective lines. To consider subjects at infrequent meetings of committees composed of over-hurried men, to debate reports of such committees in perfunctory fashion, if at all, to put forth resolutions involving practices and standards which would have utterly changed their form had there been any idea of enforcing them—these are the methods of a day now past.

The times call for bodies which will obtain intelligent and complete data and make it available for everyone, that will procure adequate discussion and the careful formulation of enforceable recommendations—and that finally will see to their enforcement.

To preserve a measure of the individual initiative which has brought American railways to their present generally efficient state, part of that initiative must be sacrificed.

It will be hard to do this. It would be easier to sit still and lose it all. But if the officers of strong roads wish to make the best fight they can for the independence of their own properties they will agree among themselves upon a uniform application of correct operating principles, and then go out into the highways and hedges and compel their deficient neighbors to come in.

It will take time and thought and much hard work, but it can be done.

# THE SUPPLY DEPARTMENT OF THE RAILWAY.

Its Purposes and Functions and Their Importance, and Its Proper Place in the Organization of the Operating Department.

BY GEORGE G. YECMANS.

The manufacture and sale of transportation is the most complex industry of the business world. The attraction which the railroad business possesses for the average man lies in the great variety of the problems which it presents for solution. Even in the daily routine of operation the unexpected is constantly occurring, and must be met by the ready resourcefulness of the individual, but its real attractiveness lies in the multiplicity of the functions which are inherent in its organization. No matter what the natural taste or inclination of the individual may be, if it leads him toward the strenuous activity of modern business life, his energies may find a suitable outlet in one or more branches of the railway service.

The traffic department typifies the art of true salesmanship, with all that the word implies.

The studious investigator of facts, as disclosed by figures, finds ample scope for his talents in the accounting and statistical departments.

The transportation department presents a wide range of opportunity for the man whose nature craves a position on the firing line; the man of executive ability, who does not shirk responsibility.

The trained engineer finds work ready to his hand in any branch of his profession, civil, mechanical, hydraulic, electrical, structural, architectural.

The large repair shops which every railroad maintains afford an outlet for the energies of the practical mechanic, and their successful management calls for a high order of mechanical as well as executive ability.

All of these different phases of the railroad life are more or less familiar because they come quite prominently into public view. Their nature, and the opportunities they offer for individual success, are so well known as to need no extended explanation of their advantages or disadvantages.

But there is a branch of the service about which little has been heard until within recent years; which, while it occupies a sphere peculiarly its own, is, at the same time, closely allied to the other departments, and which affords another important but less well known opening for preferment in the railroad service. This is the supply department. In its modern form this department is of comparatively recent origin, and as a matter of fact is still only partially developed, but its possibilities as a factor in railway economies are being slowly demonstrated and recognized. The main obstacle in the way of its more rapid progress is the fact that its real work, its capabilities and its limitations, have not been sufficiently crystallized to afford an undisputed basis for the organization to rest upon, or for the formulation of definite and uniform methods of operation.

A great many of the more conservative element still contend that there is nothing to be gained by such an organization, and that the old system, under which the head of each department procured and cared for the material which he required, is the best. Nevertheless, the general plan of having such work performed by a separate organization is constantly gaining favor. A good many railroads today have a supply department, but very few of them are alike either in management or methods. They are in all stages of development and consequently present varying degrees of usefulness. The results so far obtained under these differing systems are not uniform, and are not always what have been expected or hoped for, and this sometimes leads to a hasty condemnation of the department as such, instead of the faulty

organization or inferior methods which have been relied upon. What is most needed at present is a clear and definite idea of the proper functions of such a department, of the importance of the work which it undertakes to do, of the reasons for its existence, and of the form of organization and method best calculated to produce the sought for results.

## THE NATURE OF THE DEPARTMENT'S FUNCTIONS.

The supply department typifies the commercial or mercantile phase of the railroad business. It gathers supplies from widely separated sources, receives and cares for them properly, warehouses them when necessary and distributes them, when required for use, to the other departments which are its customers; and it carries on this business in a systematic and methodical manner which insures the best return to the company for the money invested.

It is really merchandising of a high order. The general conception of a railroad storekeeper is a man whose duties consist in arranging a large variety of articles neatly on shelves or in orderly piles, and in handing them out over a counter on demand. There is a popular impression that this is not railroading, and that the storehouse affords no avenue of approach to the real business of transportation. This may have been true once, but it is so no longer. There is the same relation between the man handling bolts in the storehouse, or tallying lumber in the yard, and the manager of the supply department, that there is between the apprentice in the shops and the superintendent of motive power, and the duties of these higher officials are of at least equal importance in the scheme of railroad administration. Further, there is no other one department which comes into such close contact with the daily activities of every other branch of the service, and none which affords equal opportunity to those engaged in the work to learn something of the operations and methods of *all* of the other departments. The man who is thoroughly in earnest, who is determined to really learn the railroad business in all its branches, and is not content with the mere performance of his allotted task, will find no better training school for his talents than the supply department.

Because of its recent origin and its imperfect stage of development, because of the importance of the work it is attempting and the possibilities that lie behind its successful accomplishment, the supply department presents the widest field that is open today in any branch of the railroad service for individual endeavor and achievement. Its real business, which lies at the root of all its activities, is the management of the company's investment in material.

This must not be confused with managing the amount expended for the material that is used in maintaining and operating the railroad. That is an entirely different thing, although the distinction is not always so clear as it should be. Broadly speaking, the aim of every operating officer is to expend money for material only as it is currently used, and if all the necessary supplies could be promptly procured when they were needed there would be no investment in material. But it is necessary that every railroad should have, at all times, a sufficient quantity of material ready for instant use to insure the continuity of its operations and the most economical employment of its working forces. This involves the storage of a certain amount of supplies of a widely diverse nature, which must be so handled as to be instantly available for use when needed, and in this way a continuing investment in material is created.

It is the province of the supply department so to manage and

\*An address delivered before the Business Club of Harvard University.

to regulate this investment as to afford the maximum of insurance at the minimum cost, and this involves a good many things.

#### THE IMPORTANCE OF THE WORK.

The importance of this work, and its possible effect on the economical management of the railroad, may be gleaned from official statistics. In 1910, the last year for which definite figures are available, so far as I know, the amount expended by the combined railroads of this country for material used in their operation and maintenance was \$247,000,000.

During the three years prior to that time the average value of material reported to the Interstate Commerce Commission as being on hand at the date of the report was \$220,000,000. The first figure represents the value of the material used or consumed in the period of one year. The second figure represents the continuing investment in material. In other words it represents unused material, carried on hand from month to month throughout the year, to provide against contingencies, and is in excess of the quantity actually used.

It is the relation between these two figures that the supply department is called upon to regulate.

The material used by the railroads, including fuel, constitutes the largest single item of expense, except the pay roll. It consumed in 1910 over 17 per cent. of their gross earnings. The pay roll in that year took about 42 per cent., but the interest on their funded debt only amounted to about  $13\frac{1}{4}$  per cent., and there was no other single item of expense that exceeded 5 per cent. of the gross revenue. The continuing investment in material almost equals the annual expenditure for material actually used, and the proper management of that investment is surely a matter of sufficient importance to demand our best endeavors. Statistics will also help us to understand why some better methods, than those which have been commonly employed in managing this investment, are desirable. The material ordinarily carried in stock is solely for the maintenance and operation of existing properties. Consequently, there ought to be some relation between the extent of those properties and the service performed by them and the amount of the investment in material.

During a period of thirteen years, ending in 1909, the miles of road operated increased 28 per cent. The miles of track increased 41 per cent. The number of locomotives in service increased 59 per cent.; the number of cars 71 per cent. The combined percentage of increase in these items was 66 per cent. The number of tons moved one mile increased 84 per cent., while the fixed investment in material increased 225 per cent. in the same period. This does not look quite right on its face, although the comparison instituted is a very rough one at best. It seemed apparent, however, that this large investment was getting out of control and growing to undue proportions, and the effort to regulate it if possible has led to the establishment of the supply department.

It is obvious that if any definite results were to be obtained the whole subject of material must be reduced to some concrete form. There must be some way of securing definite, accurate and comprehensive knowledge of the transactions in material as such, and as a whole, without regard to divisional or departmental lines. It is also plain that in order to form a reliable basis for action this information must be entirely uniform in character and must embrace all classes of material. This was practically impossible where each department was independently responsible for the material which it was using.

The simplest and best remedy was to transfer the entire responsibility for work of that nature to a body of men working under a single supervision, to accomplish that particular result, with nothing to divert their attention from the main issue. This feature was lacking under the old system. To the men who are actually doing the work, material is only a means to an end, not the end itself, and consequently it receives only secondary attention. Moreover, the only thing that vitally concerns them about material is its absence—not its presence—and yet it is the latter which constitutes the investment which it is desired to

regulate. When there is plenty of material on the ground their attention is demanded by more important matters than the mere detail of handling and caring for it. This is natural and right, but it helps to explain the increase of 225 per cent. in the investment, and the necessity of entrusting the management of this investment to men who have no more important duty assigned to them.

Before the introduction of the supply department as an independent element, the head of each operating department was practically supreme in regard to all material required for the operations under his charge. He procured the quantity he considered it advisable to have, and accounted for its use by means of monthly reports to the auditor. His accounts were accepted as correct because nobody else knew anything about them, and their accuracy was demonstrated by an annual inventory, which he took himself, of the material in his charge.

#### WHY THE SUPPLY DEPARTMENT SHOULD BE INDEPENDENT.

It is not a good arrangement to let the one who is directing or actually doing the work control the accounting for the material that is used in it. He should be at liberty to specify the kind, quality and quantity required for actual use on the work in hand, and should draw his requisitions on the supply department accordingly, but it is better that the actual handling and accounting for it should be done by a disinterested party. This introduces a systematic check not only on the use of material, but upon its abuse, waste or loss, which is often of great advantage to the head of the other department himself, as it sometimes brings to his personal attention shortcomings on the part of his own subordinates which might not otherwise be exposed. It is not at all a question of distrust of the individual, as many are inclined to infer, but purely one of good organization and of instituting proper safeguards about the investment in material wherever practicable.

In turn each of the other departments constitutes a separate check on the operations of the supply department, as they jealously watch the amount which is charged to them for the material with which they are supplied.

Briefly then, the supply department, when properly organized presents a comprehensive and condensed view of the entire situation as regards the transactions in material which cannot be so clearly obtained in any other way. It ensures better care, and thus helps to prevent loss and waste, and provides a more accurate accounting for material as such, than is possible under a divided responsibility or under conditions which render such work of secondary importance. It introduces the element of a systematic and disinterested check on the use of material by all the other departments and is in turn checked by them.

By concentration of the control and supervision of all material it renders the stock as a whole more flexible, prevents unnecessary duplications, and ultimately produces economy in handling it.

Most important of all, it permits of an intelligent regulation of the whole investment in material, and its adjustment to the actual requirements of the service in a manner not otherwise practicable.

While this is a difficult task it is entirely possible to accomplish it. The investment must be large enough to render it humanly certain that no lessening of the ordinary daily receipts of material will delay the regular, orderly and economical progress of the work. Anything less than enough creates incalculable loss, and anything more is sheer waste, for unapplied material is only money in another form, and unnecessary material is money thrown away.

Directly involved in any real regulation of this investment are the functions pertaining to the supply department. They include the procuring of all of the requisite material, the handling of all material as it is received and its distribution to the work, the custody and care of all unused material, and finally the accurate accounting for all material coming into its possession, in such a manner that the entire transactions connected with it shall be clearly and briefly placed before the executive officers.

## SHOULD HANDLE AND ACCOUNT FOR ALL MATERIAL.

I want to emphasize the use of the word "all" in this connection. No half way measures are available. It is divided authority that is responsible for the conditions which have made the supply department a necessity in the scheme of railroad organization.

The fundamental principle underlying its work is the regulation of the stock of material, but you cannot regulate anything if you do not control it, and you cannot regulate the whole, if you control only a part. This applies with peculiar significance to the material used by a railroad, because the very nature of the work demands that it be scattered over wide areas, and renders adequate supervision almost impossible unless it is coupled with actual physical control. This feature of the work has been one of the great drawbacks to the success of the department on many railroads, and constitutes one of the main reasons for their failure to produce the results expected. In some cases this has been due to the supply department itself. In its present anxiety to show an economical performance it loses sight of the effect on future results, and permits, or even encourages, other departments to continue the performance of duties which should pertain to it alone. In other cases the management has either feared to entrust the physical handling of the material entirely to the supply department on account of its imperfect development, or has been persuaded that it is more economical to have such work done by the forces available from the other departments.

There has seldom been a greater fallacy than this seriously entertained, or one more plausibly presented by those who seek to retain unhampered control of the unused material.

The true situation is this: Under the old methods, where each department handled its own material with its own forces, the prevailing practice was to charge the payroll labor direct to the operating accounts. No attempt was made to ascertain how much of the labor was devoted to handling the material and hence the true cost of the work was never in evidence.

The fact is, that nobody knows whether the work was being done economically or not, because nobody knows what it cost, and there are no standards to go by. The claim of greater economy, therefore, is at least open to further discussion and proof.

There are, however, a few facts that are self-evident: The company uses a certain amount of material each year. This material all has to be handled and accounted for. If this work is properly done so as to protect the company against loss, it costs a certain amount of money which the company pays, and the total cost is not less because a portion of it is charged on the books to some different account.

One of the advantages gained by entrusting the physical control of all material entirely to the supply department is the exposure of the true cost of handling it in a manner that prevents concealment, and the segregation of all the charges incurred in that class of service in such a definite and precise manner as to permit of close scrutiny and effective supervision, a thing that has never been accomplished in any other way.

The ultimate effect of such a course is real economy in the cost of handling material, which is at best an unwelcome but necessary expense.

The failure to form a concise and definite idea of the real functions of the supply department has led to some misconception of the place which it should properly occupy in the established organization of the railroad. All kinds of places have been assigned to it by its advocates and its adversaries, and there still seems to be a great diversity of opinion among managing officers, judging from the various forms of organization that are found on different railroads.

## RELATION TO THE PURCHASING DEPARTMENT.

One of the chief points of confusion appears to be its position with relation to the purchasing department. This arises chiefly from two causes: First, when the supply department was originated, the purchasing department was the only one in the

field whose functions pertained exclusively to material; and, second, the failure to distinguish between the act of purchasing material and the function of procuring material which must be exercised by the supply department in its work of stock regulation. The distinction is, however, very real.

Perhaps the true position of the department will be more clearly understood if we reflect that no new or original duties were imposed on it when it was established. Its work consists solely of carrying out certain duties which had previously been attempted by the other branches of the operating service, each for itself, and which were transferred to the new department. It is virtually composed of those parts of each of the other operating departments whose duties were co-related, and consisted of procuring, handling, distributing and accounting for material.

This seems to fix the official status of the department on a footing of equality with the other operating departments, and to place the chief supply officer on the staff of the chief operating officer to whom the heads of those other departments report. There is no more reason why the head of the supply department should report to the purchasing agent than there was for the heads of the other departments to report to him when they were handling their own material.

I like to think of the supply department, not as something separate and distinct from the other operating departments, as they are with respect to each other from the very nature of their duties, but as an integral and vital part of each one of those other departments from which it has sprung; giving each of them its best efforts, because their work is its work; serving them better if possible than they could serve themselves, yet not subservient to them.

This whole question will some day settle itself in a satisfactory manner, on the basis of results obtained and their relation to the net earnings. The real significance of the work is rapidly dawning on the railroad world, and with the realization of its importance comes the demand for bigger and brainier men to manage this investment in material. Already the far sighted executives of four of our largest western systems have given the rank of vice president to the heads of their supply departments and are making this branch of the service as attractive as possible to ambitious and energetic men. One of the greatest needs of the railroads today is properly organized control and systematic regulation of their investment in material by men who have not only fully grasped the practical side of the many difficult questions involved, but who thoroughly understand the true relation of those practical questions to the still greater questions of railway economics. They need trained thinkers, men of brains and of ideals, working in their storehouses and mastering the problems of practical detail in their supply yards, men who will see and comprehend the true importance of the results which hang on their efforts, and will one day be able successfully to direct the management of the company's investment in material.

NEED FOR RAILWAYS IN NEW SOUTH WALES.—The demand for more railways in New South Wales is becoming more acute. The Minister of Railways, together with the progressive section of the Legislative Assembly, is convinced that increasing transportation facilities must be provided without further delay. The development of the country is being seriously retarded; and the rate of railway construction which has obtained hitherto, is so painfully slow that it will take years to relieve the situation to any appreciable extent. Meanwhile, ambitious farmers and new settlers are becoming impatient at being landlocked and unable to get their products to market. The Minister of Railways, being aware of these facts, also recognizes that further delay in putting forward a practical program of construction would not only increase the difficulty of procuring the necessary funds in the London market, but would also mean that the taxpayers would have to pay higher rates and charges, seeing that other countries needing urgent development are offering higher terms to English capitalists.

TRAIN ACCIDENTS IN SEPTEMBER.

Following is a list of the most notable train accidents that occurred on railways of the United States in September, 1913:

Collisions.

Date.	Road.	Place.	Kind of Accident.	Kind of Train.	Kil'd.	Inj'd.
†2.	N. Y. N. H. & H.	North Haven.	rc.	P. & P.	21	33
†22.	Long Island	College Point.	bc.	P. & P.	3	71
23.	Georgia	Greensboro.	rc.	F. & F.	1	2
24.	Buffalo, R. & P.	Indiana, Pa.	xc.	F. & F.	0	5
25.	C. C. C. & St. L.	Joan.	rc.	F. & F.	1	9
26.	Yazoo & M. V.	Kenner, La.	rc.	P. & F.	0	3
23.	Atlantic C. L.	Beresford, Fla.	bc.	P. & F.	1	4
29.	Delaware & H.	Lanesboro.	bc.	F. & F.	3	1

Derailements.

Date.	Road.	Place.	Cause of Derailm't.	Kind of Train.	Kil'd.	Inj'd.
9.	Pennsylvania	Wileys, Ohio.	unx.	P.	1	38
9.	Missouri Pac.	Boonville.	d. track.	P.	0	13
12.	Mo. K. & Tex.	Lewistown.	.....	P.	0	5
16.	Pennsylvania	Coatesville.	b. rail.	P.	0	3
18.	Chi. B. & Q.	Trempeleau.	fire.	P.	0	8
20.	Chi. R. I. & P.	Manhattan, Kan.	unx.	P.	0	20
22.	Great Northern	Mukilteo.	b. axle.	P.	1	44
24.	Bessemer & L. E.	Branchton.	unx.	F.	0	2
24.	Balt. & Ohio.	Youngstown.	d. eq.	P.	2	0

The trains in collision at North Haven, Conn., on the second, were southbound passenger trains 91 and 95, and the principal cause was disregard of an automatic block signal, indicating stop, which was passed by the second train in a dense fog. Twenty-one passengers were killed and thirty or more injured. This was reported in the *Railway Age Gazette* of September 12.

The trains in collision at College Point, N. Y., on the 22nd, were westbound passenger 311 and eastbound passenger 308. Both motormen and two passengers were killed, one of the passengers being a conductor off duty. The persons injured were 26 passengers and 29 employees off duty, 16 of the passengers being city policemen riding free. Both trains consisted of steel cars, operated by electric third rail; the westbound was running about 35 miles an hour, and the eastbound about 15 miles an hour. Of the two cars in the westbound train, one was badly damaged; and of the five in the eastbound train, none were much damaged. The eastbound train had been allowed to pass from double track to single track on the time of the westbound, which was superior by direction. The collision occurred a short distance from the end of double track. At this point, which is a junction, the signalman in charge of the interlocking tower, gives eastbound trains the right to the road, the conductor and motorman not being required to examine the train register. The action of the signalman in allowing train 308 to proceed, when he knew that 311 was due and was superior, is inexplicable; he had just been asked by the dispatcher concerning 308, which was behind time. The manual block system, to be worked by means of telephones, had been authorized for this section of the road, and it was put into use on September 25, three days after the collision.

The trains in collision near Beresford, Fla., on the 23rd, were a southbound passenger and a northbound locomotive running without a train. One engineman was killed, and four others were injured. Both engines and two cars were badly damaged. The northbound train had encroached on the time of the southbound.

The trains in collision near Greensboro, Ga., on the 23rd, were eastbound freights. A flagman was killed and two other trainmen were injured. The collision was due to the failure of the flagman to protect his train by throwing off a green fusee when it was losing time.

The trains in collision on the Buffalo, Rochester & Pittsburgh, at Indiana, Pa., on the 24th, were a southbound special train carrying officers of the road, and a freight train which was en-

tering a side track but had not cleared the main line. Three officers of the road, one official car attendant, and a flagman were slightly injured. The men in charge of the freight train had overlooked orders regarding the movement of the special.

In the collision at Joan, Ill., on the 25th, an eastbound work train ran into the rear of a preceding freight train, damaging the engine and five cars. A brakeman was killed and two conductors and three trainmen and six laborers were injured. The collision was due mainly to the work train not running under control, under a permissive block signal.

The trains in collision near Kenner, La., on the 26th, were westbound passenger train No. 1 of the New Orleans, Texas & Mexico and a preceding freight. The passenger ran into the freight at pretty good speed; and the locomotive, baggage car, caboose and six freight cars were wrecked. The engineman, fireman and one passenger were injured. The collision occurred at 8 p. m., and was due to improper flagging.

The trains in collision near Lanesboro, Pa., on the 29th, were northbound and southbound freights, each running at about 8 miles an hour. One fireman was slightly scalded and three trespassers, riding on the back end of the tender of one of the engines, were killed. The northbound train, in passing around another train ran past a stop signal and through a crossover to the southbound track, there colliding with the southbound train.

The train derailed near Wileys, Ohio, on the 9th, was westbound passenger No. 31, the "Twenty-Four Hour St. Louis," and 14 passengers, 23 employees and two postal clerks were injured, one employee, the fireman, being fatally scalded. The list of employees includes 10 in the dining car and seven Pullman employees. The train was running at about 55 to 60 miles an hour, and all but two of the eight cars in the train were derailed, one being overturned. All the cars were of steel. The engine was overturned and knocked down one girder of a bridge. This part of the road was not washed out during the March floods, as was reported. The curvature of the line at the point of derailment was one degree, 43 min. Two rails were found broken, but they were beyond the point of derailment and there was no evidence that the derailment was caused by a broken rail.

The train derailed near Boonville, Mo., on the 9th, was westbound passenger No. 32, and ten passengers and three trainmen were slightly injured. The derailment occurred near a bridge and the engine and baggage car broke through and fell into a creek. The derailment was due to breaking of an angle bar.

The train derailed at Coatesville, Pa., on the morning of the 16th, was an eastbound express. All of the cars in the train were of steel construction. The last car of the train was overturned. Three passengers were slightly injured. The cause of the derailment was a broken rail.

The train derailed near Trempeleau, Wis., on the afternoon of the 18th, was the Oriental Limited, No. 52. The train was going at full speed when it entered on a trestle bridge which was afire, but the condition of which had not been seen by the runner in time to stop, the line being curved. Eight passengers were injured, none seriously. The baggage car fell off the bridge at the right hand side and four passenger cars were derailed; three of the passenger cars were badly damaged by the flames.

The train derailed near Mukilteo, Wash., on the 22nd, was an eastbound passenger, No. 4. One employee was killed and 35 passengers, eight employees and one other person were injured. The tender was derailed by the breaking of an axle and, with the engine and baggage car, was ditched. A westbound train was derailed by a part of the wreck, but was not much damaged.

The train derailed at Youngstown, Ohio, on the 24th, was eastbound passenger No. 10, and the engineman and fireman were fatally scalded. The engine was overturned, though it was moving only about eight miles an hour. The derailment is said to have been due to the pilot of the engine catching on a frog.

Canada.—In a butting collision of freight trains on the Intercolonial near Aulac, N. B., on the 23rd of September, four trainmen were killed. The westbound train had run past a station where it should have waited for the eastbound

<sup>1</sup>Abbreviations and marks used in Accident List:  
 rc, Rear collision—bc, Butting collision—xc, Other collisions—b, Broken—d, Defective—unf, Unforeseen obstruction—unx, Unexplained—derail, Open derailing switch—ms, Misplaced switch—acc, obst, Accidental obstruction—malice, Malicious obstruction of track, etc.—boiler, Explosion of locomotive on road—fire, Cars burned while running—P, or Pass, Passenger train—F, or Ft., Freight train (including empty engines, work trains, etc.)—Asterisk, Wreck wholly or partly destroyed by fire—Dagger, One or more passengers killed.

# CONSTRUCTION OF CLINCHFIELD EXTENSION.

Building a 35-Mile Line Over the Cumberland Range to Give the Carolina, Clinchfield & Ohio a Northern Connection.

The Carolina, Clinchfield & Ohio was built to furnish a direct outlet from the soft coal fields in southwestern Virginia to the markets in the South Atlantic states. This line, which has been operated since 1910 from Dante, Va., the base of operations of the Clinchfield Coal Corporation, south across the Blue Ridge Mountains to Spartanburg, S. C., offers a considerably shorter route for this coal traffic than was available over the lines paralleling the Appalachian chain, and the high standards to

A line to connect these points must cross the Sandy Ridge of the Cumberland mountains, which presented so great difficulties to the construction of a satisfactory road that several previous attempts had been unsuccessful. A line was located between Dante and Elkhorn in 1881, and in 1900 the South & Western, predecessor to the Carolina, Clinchfield & Ohio, ran a large number of lines on high and low locations and various standards of curvature and grade. A 16-deg. line could have been fitted to this country quite easily, but in view of the high standards adopted on the remainder of the line and the heavy traffic which is expected to develop, 10-deg. curves were adopted as maximum in the final location, with a resulting increase in the cost of construction of about \$1,500,000. Contracts were let for the 35-mile extension in June, 1912, and the work is now nearly completed. It is expected that track will be laid and ballasted over the entire line, with the exception of the Sandy Ridge

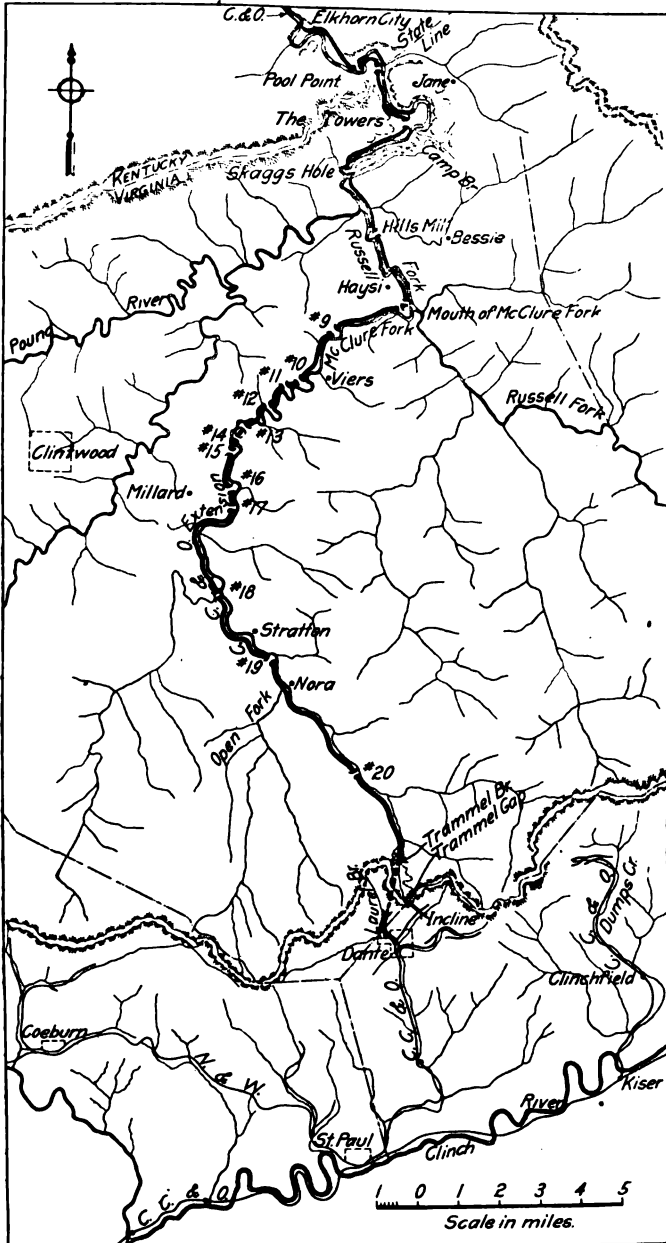

Map of the Elkhorn Extension of the C. C. & O.



South End of Caney Creek Tunnel, Which Was Driven by Hand.

tunnel by the end of this year, and the tunnel should be finished by August, 1914.

It is expected that a large amount of through business with the Chesapeake & Ohio will be handled over this connection in addition to the coal and lumber originating in the new territory that will be opened up. Through passenger service will probably be inaugurated, and as this line will offer the shortest route from Cincinnati and northern points to the Carolinas, Georgia and Florida, and will traverse a country that is rarely excelled for natural beauty, the operation of such through passenger traffic should be profitable.

#### GRADES, CURVATURE AND QUANTITIES.

With the exception of a little more than a mile at the Dante end, the grade over the entire line is descending toward the north. Dante lies at an elevation of 1,760 ft. on the south slope of Sandy Ridge. The line rises abruptly from Dante, the maxi-

which the road was built make it possible to handle this traffic economically. Having accomplished the extremely difficult task of building a good line across the ranges southeast of the coal fields, it was at once desired to secure for the new line a share of the through passenger and freight business from northern and western states by building an extension north from Dante to Elkhorn City, Ky., the southern terminus of the Big Sandy branch of the Chesapeake & Ohio.



imum rate of grade between the connection with the old line and the tunnel through Sandy Ridge being 1.8 per cent. compensated. The line reaches its maximum elevation of 1,838 ft. near the south end of the 7,804 ft. tunnel and emerging on the north side of the ridge, it follows down the valleys of McClures Fork and Russell Fork for the entire distance to Elkhorn City, where the elevation is 794 ft. To overcome this difference in elevation of 1,044 ft. in 34 miles would require a continuous grade of about 0.6 per cent., so that to secure a practicable line a maximum grade considerably higher than that had to be adopted. North of the summit the grade through the tunnel is 0.5 per cent. From the north portal the line drops down in the valley of McClures Fork on a 1 per cent. compensated grade for about six miles. Just north of the tunnel the new road is 100 ft. above the adjacent stream, and at the bottom of the six-mile section it is only about 20 ft. above water level, which approximate difference in elevation is maintained for a considerable distance. On the next 20 miles the grades are practically the same as the fall of the stream, 0.2 and 0.3 per cent. being the prevailing rates for nine miles, and 0.35 and 0.7 per cent. for the remaining 11 miles. About five miles from Elkhorn City the Pine range is passed in a deep canyon occupied by Russell Fork, and from there to Elkhorn the descent is on a maximum grade of 1.5 per cent. compensated. The heavy grades at both ends of the line will require the operation of pushers out of Dante and Elkhorn City. Mallet locomotives will probably be used on the extension, hauling 2,700 tons with 2-8-0 pushers on the two heavy grades.

As stated above, the maximum curvature is 10 deg. The largest central angle is 136 deg., 42 min., and the total curvature on the line amounts to 6,580 deg., 28.5 min., or an average of about 188 deg. per mile. All curves of 3 deg. and over are spiralled. The longest tangent on the line is in the Sandy Ridge tunnel, being about 9,750 ft. The next longest is near the Elkhorn end and is only 2,500 ft. long. The percentage of tangent is 45.7 per cent.

Practically the entire line is on side hill as the location follows the streams very closely, cutting through tunnels wherever necessary to save distance. In the 35 miles there are 20 tunnels, with a total length of 3.9 miles, so that more than 11 per cent. of the new road had to be tunnelled. The excavation quantities total about 2,250,000 cu. yds., of which about 70 per cent. is rock, in addition to between 300,000 and 400,000 cu. yds. removed from the tunnels. The grading, exclusive of tunnel work, averages somewhat over 71,000 cu. yds. per mile. The masonry is not heavy, being only a little over 1,000 cu. yds. per mile. The total cost of the line is, in round numbers, \$5,000,000, an average of somewhat over \$140,000 per mile.

#### METHODS OF HANDLING, GRADING AND TUNNELING.

Although the work is very heavy, the most difficult problem was in getting in material and supplies. The country is extremely rough and in most cases the contractors found no roads suitable for heavy hauling. All equipment and supplies were hauled from four points: Dante; Elkhorn City; Norton, Va., where the L. & N. and Norfolk and Western connect; and Indian, Va., the terminus of a lumber road running north from Honaker on the Norfolk & Western east of the new line. The haul from either of the latter points was from 20 to 30 miles, and in some cases heavy machinery such as steam shovels, compressors and boilers had to be hauled for such distances over the steep mountain roads that were very poorly laid out and maintained. It was necessary for the contractors to spend considerable money in improving the roads and maintaining them during construction work. Steam shovels were used quite generally for handling the excavation on the line in spite of the difficulty in getting in heavy equipment. In all, 13 shovels were in use by the contractors on the 35 miles, varying in size from 20 tons up. In all cases the outfits used with the steam shovels were narrow gage equipment. A fairly large proportion of the

excavation was made by hand. In one case a gang of Swedes had a sub-contract for a section about one mile long in which they handled 30,000 cu. yds. of material entirely by barrows.

Most of the small tunnels were driven by putting through a heading for the full length and then taking out a bench to the full tunnel section. Mule carts or small dump carts were used in most cases for taking out the muck. In one case a small steam shovel was used for loading these cars. The timber lining for the tunnels was secured along the right of way, the contract for cutting this timber being given to a local man. Caney Creek tunnel, 400 ft. long, was taken out entirely by hand. The material was a soft slate with a coal seam which proved to be exceptionally good material for ratchet drills. Steam drills were used in two tunnels, and in all other cases air was used.



South End of Sandy Ridge Tunnel.

As an example of the tunnel plants that were installed at points where it was very difficult to get in machinery, the air compressor used by one of the contractors in driving three tunnels about 17 miles from Dante was an Ingersoll-Rand AA2 with cylinders 20¼ in. and 13¼ in. by 18 in. The heaviest pieces handled weighed from three to 3 1/3 tons, which had to be hauled for the entire distance over the very rough mountain roads.

#### THE SANDY RIDGE TUNNEL.

The connection with the old line at Dante is made near the present passenger station, the new extension turning to the left to follow Laurel branch to the south entrance to the Sandy Ridge tunnel. About 550 ft. of concrete culvert had to be built to carry this stream in a new channel alongside and under the

new line. Several sections of retaining wall with a total length of 286 ft. were built to retain the embankment along this stream. These culverts had mass abutments and I-beam encased decks.

cut has a maximum depth of about 85 ft. and contained 70,000 cu. yds. of material.

The tunnel under Sandy Ridge is 7,804 ft. long and is about

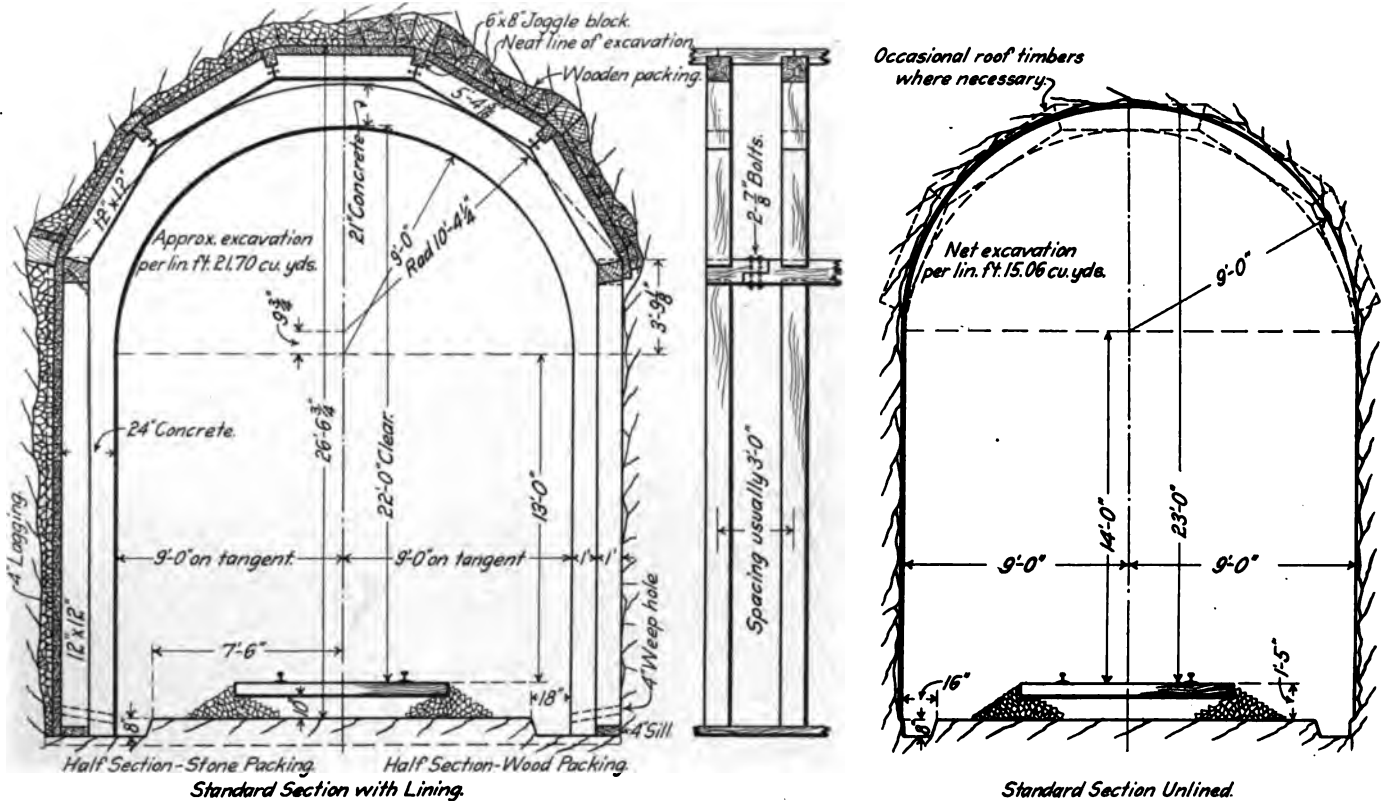

Standard C. C. & O. Tunnel Sections.

The foundations are 1:3:6 concrete and the tops are 1:2:5 and 1:2:3 concrete. The south approach cut to the tunnel and the necessary stream changes were made by two Bucyrus 70-ton steam shovels with standard gage equipment. The approach

900 ft. under the summit of the ridge. The cross sections used for all tunnels on the line are shown in one of the accompanying drawings. About 255 ft. at the north end of this tunnel was in badly broken material requiring lining, but it is not

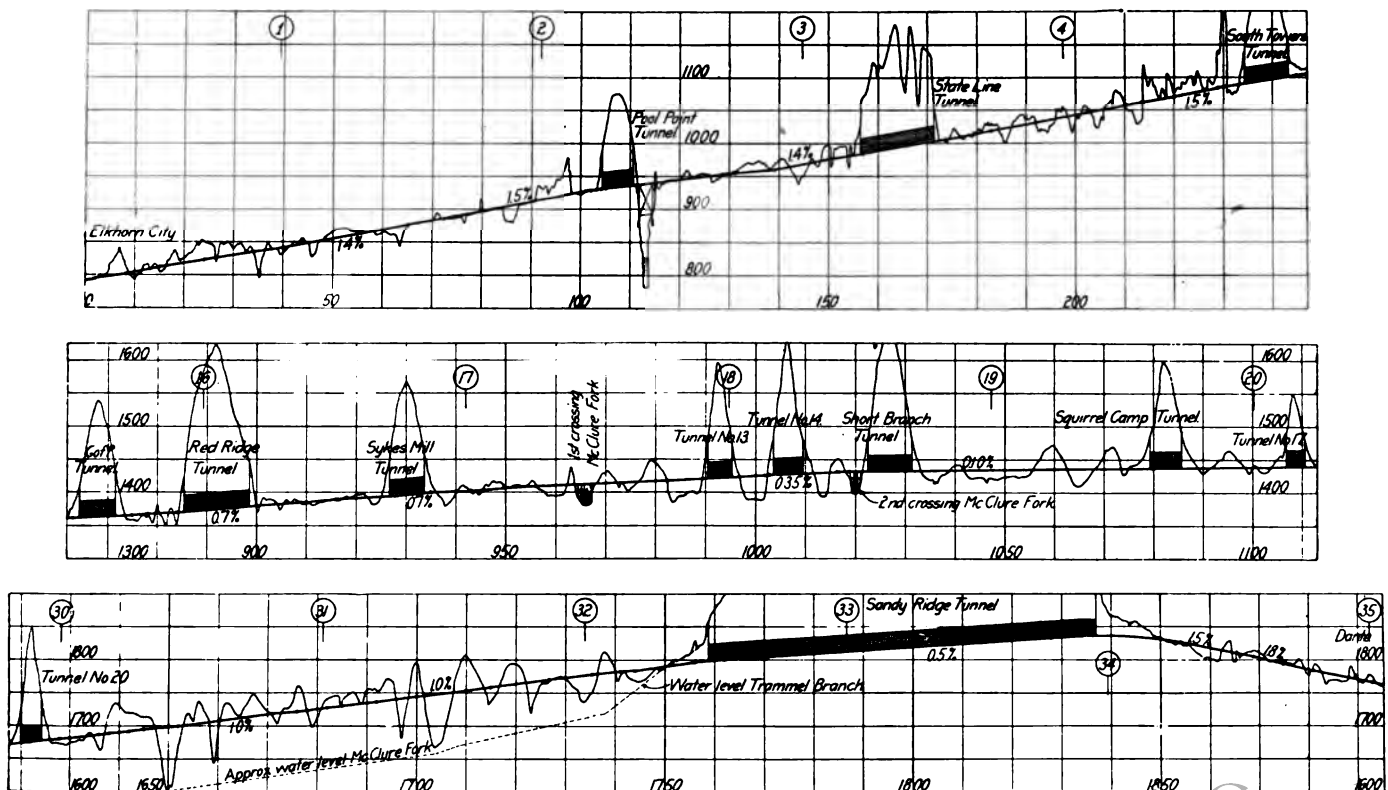

Three Sections of the Profile Showing Some of the Heavy Grading and Tunnel Work.

expected that the remainder of the length will require it. The tunnel is being driven from both portals, taking out the full section as the work progresses. The headings are kept only about 12 ft. ahead of the first bench, to provide room for the drills to put in a round of heading holes while the muck from the last charge is being removed. Four  $3\frac{3}{4}$  in. air drills are used in the heading to place about 22 holes in each round. The drills are mounted on columns in the heading and on tripods on the benches. The bench is taken down in two levels, the upper one having six vertical holes in each charge and the lower four. The charges are made with 60 per cent. dynamite.

hour with a drawbar pull of 2,800 lbs., and the smaller 6.8 miles per hour with a pull of 2,000 lbs. The tunnel muck was at first dumped in a big waste bank near the tunnel, but later it was hauled to Dante, where it was used for grading a small yard. In order to load the muck into standard cars a temporary trestle was built along the new standard gage track in the tunnel approach cut at a grade high enough to allow the dump cars to be dumped directly into the C. C. & O. cars. The electric locomotives pulled the muck trains upon this inclined trestle.

The electric and air plants which have been installed in duplicate at the two ends of this tunnel are very completely equipped



Piers for Open Fork Bridge.

In each round, the lower bench is shot first and this is followed by the upper bench and then the heading. The material is of hard slate and sandstone lying in heavy ledges, some of which are as much as 10 ft. thick.

All material is handled by Marion 41 shovels, operated by air and equipped with  $1\frac{1}{2}$  yd. buckets. Four-yard dump cars are handled in trains of five by electric locomotives similar to those used in the coal mines in that district. Two types of these locomotives are in use, rated at five and six tons, respectively. The larger type develops a speed of eight miles per

and represent a total outlay of between \$60,000 and \$75,000. The electric power is secured from a power house of the Clinchfield Coal Corporation on Dumps creek, about eight miles from the tunnel, where current is generated for the company's mines. This power is transmitted at 6,600 volts a.c. on a three-wire transmission line, and is transformed at the tunnel plants to 2,300 volts a.c. by three G.E. type H, 60-cycle, 125-k.v.a. transformers. This 2,300-volt current is used in a motor-generator set to produce 250-volt d.c. current for the lighting circuit and for operating the electric locomotives hauling the

muck trains. Separate lighting and power circuits are run into the tunnel and along the approaches, the locomotives being operated by a trolley system. Electric lights are provided in the roof of the tunnel on the center line one foot below the roof grade for the use of the foremen in getting line and grade.

Compressed air for drills and shovels is furnished by Ingersoll-Rand Imperial type air compressors belt driven from 300-h. p. motors. These compressors have cylinders 25 in. x 20 in.

pair parts is carried at the site of the work to eliminate delays. A No. 7 Cameron pump is in service at the south portal and a



Skag's Hole Tunnel.

and 15 in. x 20 in., respectively. The air is carried at 110 lbs. pressure in an 8-in. line down into the approaches and tunnel headings. Ingersoll-Rand E-44 drills are used, and in addition to the eight drills in each heading, air is supplied to the shovel, two pumps, two well drills and a drill sharpening machine. The latter is operated by two men and is able to sharpen about 200 drills during the day shift. A full stock of drills and re-



Pool Point Looking Across River Toward North.

14-in. fan line has been installed for ventilating at each end. This ventilating equipment is designed either to draw the air



North Portal of Skag's Hole Tunnel.



Benching Off Rock at "The Towers" Instead of Tunnelling.



North Heading of Towers Tunnel.

away from the working face or to blow in a stream which can be directed back from the heading to create a draft. About 100 ft. of the complete tunnel section is finished per week.

On account of the extreme difficulty of hauling the heavy equipment needed at the north portal over the rough mountain road from Dante, an incline was built from a mine spur along Middle Fork about one mile north of Dante. This incline is

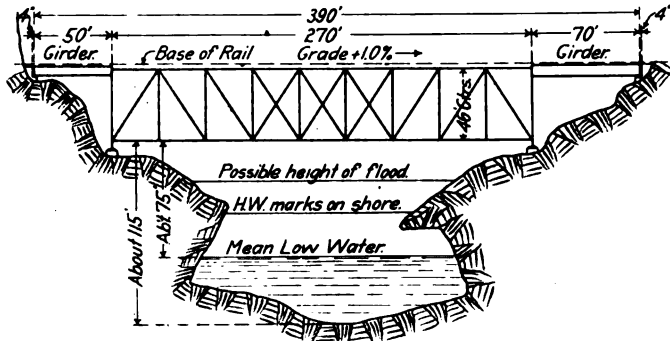

Elevation of Pool Point Bridge.

about 2,500 ft. long, with an 800-ft. rise, the grade having been fitted closely to the surface of the ground. The top reaches a saddle in the ridge known as Trammel Gap, from which the material can be handled down the north slope to the tunnel plant. Three-foot gage cars with a capacity of about five tons are pulled up the incline by a 3/4-in. cable wound on the drum of a 100-h. p. motor-driven engine located at the upper end.



Looking North from Top of Pool Point Tunnel.

A cement and feed house is located at the top of the incline to store perishable material which cannot be hauled away immediately, although every effort is made to handle material as fast as the incline brings it up. The haul to the compressor plant is about two miles, and two specially constructed wagons of

14 tons capacity were built to handle the heavy equipment, such as compressor parts and steam shovels.

The north approach cut is about the same depth as the south and, as mentioned above, the electric and air plant is identical with the one at the other portal. The line emerges from the north end of the tunnel in the little valley of Trammel Creek which runs into McClures Fork less than a half mile from the portal. Some channel changes were necessary to keep the water of this creek away from the line.

SANDY RIDGE TO "THE TOWERS."

The work between the Sandy Ridge tunnel and tunnel No. 20 involved the heaviest grading on the entire extension. The quantities handled in about 2 1/2 miles totaled 417,400 cu. yds. This section of the line is entirely side hill work, the line being benched into rock high above the stream which it follows. In a number of cases gasoline well drills were used for vertical drilling in the rock cuts on this section, 6-in. holes being driven down to grade. Most of the material handled in these cuts was sandstone. Fifty-foot cuts and fills were quite ordinary in this portion of the work, the maximum fill of 154,000



Spring Branch Stone Headwall.

cu. yds. being over Honey Branch, just north of tunnel No. 20, which was nearly 100 ft. high. This fill was made in two levels, the lower level being widened by operating the narrow gage dump cars around a circular track.

There are very few bridges on the line and only one that required a truss span. The line keeps to the west of McClures Fork for nearly 15 miles from the Sandy Ridge tunnel, crossing in this distance only three small creeks which required two or three girder spans each. Just beyond tunnel No. 15 the line crosses to the east bank of McClures Fork on three 72-ft. girders, passes through tunnels No. 14 and No. 13 within the next mile and crosses back to the west side of the stream on a five-span girder structure.

The grading was not extremely heavy in the central portion of the line, with the exception of the tunnels. The stream is very crooked, and in order to improve the alinement, tunnels were used very frequently, but where it was possible to follow the stream the side hill work was not unusually heavy. At that point there were eight tunnels in a little over four miles.

About 23 miles from Dante, McClures Fork empties into Russell Fork, and the new line follows that stream for the remaining distance to Elkhorn. Just north of the mouth of McClures Fork the line crosses to the east side of Russell Fork on three 100-ft. deck girder spans, remaining on that side of the stream for about three miles. The next crossing is made at

known as Skag's Hole, where the east bank of the river rises almost vertically to a height of about 200 ft. The line cuts through this ridge in a tunnel about 500 ft. long and crosses the river on a five-span deck girder structure, the south abutment of which is inside the portal of the tunnel. North of Skag's Hole the work is comparatively light for about two miles, as the west bank of the stream has an easy slope.

#### PASSING PINE RIDGE.

At a point known as "the Towers" the line cuts through a tunnel 890 ft. long and in a high ridge between the sides of a loop in the river about  $1\frac{1}{2}$  miles long. The work from "The Towers" to the State Line tunnel is the most spectacular on the whole extension. Russell Fork at this point flows through Pine ridge in an irregular canyon known locally as "The Breaks," the mountains rising on both sides from 800 to 1,000 ft. above the river. At a number of points the walls of the canyon are nearly perpendicular. It was first planned to have two tunnels at "The



Long Concrete Culvert near Dante.

Towers," the north one of the two cutting through a narrow wall of rock extending practically out to the river. As the work progressed it was found that the nature of this rock would not allow the building of a satisfactory tunnel, so that it was decided to bench off this rock wall and lay the line in open cut along the face of the bluff.

The contractor handling "The Towers" tunnel had one of the most difficult problems on the entire work in getting in equipment and material to his camp. The only access by road to this portion of the mountain is by a very long, crooked trail from Elkhorn City, which winds over the mountain from two to three miles east of Russell Fork. This trail strikes a little stream known as Camp Branch about  $\frac{3}{4}$  mile from Russell Fork and follows down this branch toward the larger stream, which flows into Russell Fork at a point almost opposite "The Towers" tunnel. On account of the inaccessibility of the west

side of the stream from the north it was necessary for the contractor to locate his camp and compressor plant along this branch on the opposite side of the river. He hauled all material from Elkhorn over the winding mountain road for 10 miles, taking apart all the heavy machinery so as to reduce the weight of individual pieces. By using six spans of mules, and in many cases helping them with blocks and tackle, he was able to get in two boilers, the heaviest of which weighed 14 tons. He also installed an Ingersoll-Rand compressor with a capacity of 790 cu. ft. per min., and laid about  $1\frac{1}{2}$  miles of 4 in. pipe from the compressor to the tunnel headings. All of this pipe, the drills and all powder used on the work had to be carried on men's backs from the camp across the river and up the steep bank to the tunnel portal. In order to reach the north portal which was worked simultaneously with the south, these supplies were carried over the top of the ridge and let down by ropes along the face of the bluff.

The State Line tunnel was much easier to reach, although it also presented many difficulties. It was driven from both portals and a side drift which was run in from the face of the canyon to allow headings to be pushed in both directions from the center. One of the contractors handling grading between "The Towers" and the state line brought in a 20-ton steam shovel over the road from Elkhorn City on the east side of Russell Fork, but owing to high water, had to wait more than six weeks before he could get an opportunity to transfer the shovel across the stream.

#### POOL POINT BRIDGE.

The largest bridge on the line is across Russell Fork just north of the state line at a point known locally as Pool Point. The grade is about 110 ft. above the water at this crossing and the north bank is so high that the line enters a tunnel immediately after leaving the bridge. In addition to a 270-ft. deck truss there is a 70-ft. plate girder at the south end and a 50-ft. plate girder at the north end. This bridge required the building of two concrete abutments and two piers which proved to be a difficult matter. The piers were located far down the rocky banks of the stream and all materials had to be hauled to the tops of the banks and lowered to these points. All concrete materials were hauled to the east side of the stream, and in order to reach the west abutment and pier, had to be transferred across the stream and then carried by men up the steep slopes and let down again at the site of the bridge. A cable suspension bridge was built across the river at a convenient location south of the crossing and a skip suspended from one of the cables was used for pulling cement and sand across the river. The stone used for the concrete was broken by hand at the site of the bridge and all concrete was mixed by hand. The east abutment and pedestal were not quite so difficult as it was possible to haul directly to a house located on the bank above these foundations. The material was chuted down from this house as required. The masonry for this bridge amounted to 125 to 130 yds. As the stream is subject to sudden and disastrous floods at all seasons, the erection of this bridge promised to be a difficult problem. The bridge company having the contract expects to use a steel A frame.

North of Pool Point tunnel the line follows the east bank of the river to the connection with the Chesapeake & Ohio just south of that company's passenger station at Elkhorn.

#### STANDARDS OF CONSTRUCTION.

The roadbed standards used on this extension called for an 18-ft. width on fills, 20 ft. in earth and 22 ft. in rock cuts. The track is to be laid with 85-lb. A. S. C. E. open hearth rails, Bonzano joints and limestone ballast. At the north end the first lift will be made on sandstone on account of the difficulty of securing a good grade of limestone in that vicinity. A crusher is being operated at St. Paul on the old line south of Dante for furnishing this ballast and a crusher on the Chesapeake & Ohio just north of Elkhorn furnishes a sandstone used for the first

lift. Passing sidings 4,000 ft. long will be provided at intervals of about seven miles.

Culverts are of cast iron pipe up to 36 in. Concrete boxes and arches are used for larger openings, the minimum box being 2 ft. 6 in. x 3 ft. Stone culverts are used in many places as an excellent grade of stone is available. At one point south of "The Towers" where the line crosses Spring Branch a 10-ft. stone arch, shown in one of the accompanying cuts, was built of stone which was secured so close to the site of the arch that the same derrick which picked up the blocks from their natural bed laid them in place in the arch. The stone in this arch is of the finest grade of brown sandstone laid in 20-in. courses in the walls and 14-in. courses in the arch. There are two short stretches of stone masonry retaining walls near this point which are also built of this sandstone.

The company made every effort to expedite the work, as it was essential that it be completed in as short a time as possible. One of the measures taken to assist the resident engineers along the line in handling their work was the building of a telephone line for the entire distance between Dante and Elkhorn. In addition to the high cost of a line through rough unbroken country, it was necessary to keep two linemen busy all the time repairing and maintaining the instruments and line. It proved a very great advantage, however, especially as all contractors' camps were also supplied with phones, enabling the engineers to get in touch with each other or with any contractor rapidly and easily. This service was naturally very much appreciated by the contractors, who made excellent use of it in pushing their work.

Instead of housing the resident engineers and their parties in temporary shacks, as is almost universally done, it was decided to locate the engineers at points where section and station houses would be needed after the completion of the line and to build these houses for the use of the engineering parties during the construction work.

PERSONAL.

The general contract for building the entire line, including clearing, masonry, grading and tunnels, was let to the Rinehart & Dennis Company, Charlottesville, Va. Hollis Rinehart, general manager of this company, has general charge of the work and E. J. Perkins is the superintendent on the ground. The Rinehart & Dennis Company is driving the Sandy Ridge tunnel and seven shorter tunnels with a total length of about 8,000 ft., and handling about 12 miles of grading. The remainder of the work was sublet to 15 companies. The American Bridge Company has the contract for erecting and fabricating all of the steel bridges. A large part of the cement used on the work was furnished by the Clinchfield Portland Cement Corporation, Kingport, Tenn. The railway company will lay the track with company forces. The entire work of location and construction is handled for the company by Ward Crosby, chief engineer. The line is divided into six residencies in charge of the following resident engineers, the order being from Elkhorn south; J. W. Moore, C. D. Stanper, J. H. Charlton, C. P. Norris, L. R. Wilcox and W. C. Hatton. We are indebted to all of the engineers and contractors along the line for courtesies extended in the securing of the above information.

POWERFUL ARTICULATED ELECTRIC LOCOMOTIVES.

The New York Central after making trials early in the present year of an eight-motor articulated 600-volt direct current electric locomotive,\* ordered nine more of the same type from the General Electric Company, Schenectady, N. Y. These locomotives weigh, in working order, 200,000 lbs., are of the 4-4-4-4 type and are equipped with eight bipolar, gearless motors, all the weight being carried on motor driven axles. They were de-

\*For description see *Railway Age Gazette*, April 11, 1913, page 841.

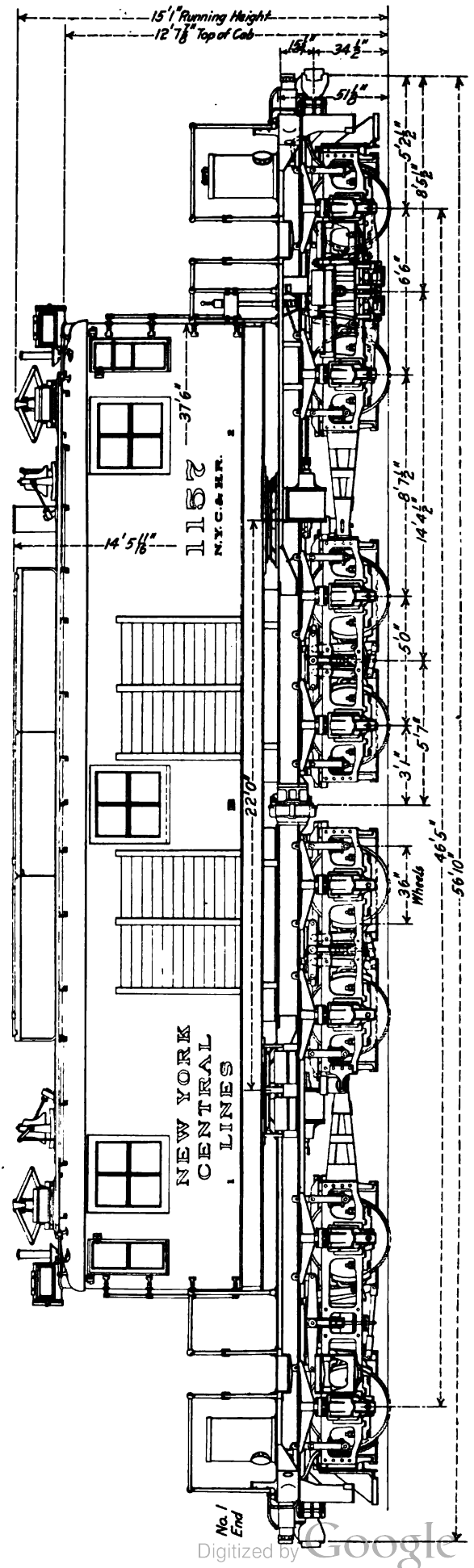

110-Ton Articulated Electric Locomotive for the New York Central.

signed for operating the heavy limited passenger trains and are capable of hauling 800-ton trains in continual service between the Grand Central Terminal, New York, and Harmon; they are also capable of operating a 1,000-ton train in emergency service, a train of the same gross weight on level tangent track continuously at 60 miles an hour, or an 800-ton train at 65 miles an hour.

As the weight of passenger trains is steadily increasing, and some of the more important trains now weigh over 1,000 tons, it has been deemed necessary to have locomotives for the maximum service with very great continuous capacity, ample overload and high momentary rating. The New York Central has therefore ordered six electric locomotives from the General Electric Company of the same type and general arrangement as the previous ten, but weighing 220,000 lbs. and of materially greater capacity for continuous service. They are capable of exerting practically the same tractive effort continuously that the previous ten locomotives can for one hour.

The ten tons' increase in weight in these machines is accounted for mainly by the greater amount of material in the motors, which are of larger capacity. The speed and torque characteristics have been kept practically the same, but the new locomotives are capable of hauling approximately 40 per cent. greater tonnage in continuous service. The previous ten locomotives can develop 1,460 h. p. continuously, 2,000 h. p. for one hour and as high as 5,000 h. p. for short periods. This corresponds to a tractive effort of 9,000 lbs. at 60 miles an hour continuously, or 13,500 lbs. at 54 miles per hour at the one hour rating. The six new locomotives will develop 2,000 h. p. continuously, or 2,600 h. p. for one hour. The equivalent tractive effort is 14,000 lbs., at 54 miles an hour continuously, or 20,000 lbs. at 49 miles an hour at the one hour rating. They are able to haul 1,100-ton trains in continuous service between the Grand Central Terminal and Harmon, 32.6 miles, are capable of operating 1,200-ton trains in emergency service, and 1,200-ton trains on level tangent track continuously at 60 miles an hour.

In point of design and construction these locomotives will be of identically the same type as the former ten, having an articulated frame with guiding trucks at each end. The cab containing the engineer's compartment and that for the operating mechanism, is swung between the two parts of the frame on center pins. Each section is equipped with two four-wheel trucks having a driving motor mounted on each axle, all the axles, therefore, being driving axles. The eight motors, of the bipolar gearless type, are of the same general design as the motors on the previous 57 locomotives built for this road, and are provided with ample forced air ventilation. They are electrically connected permanently in parallel in pairs and the pairs can be connected in three combinations—series, series-parallel and parallel. They are insulated for 1,200 volts, so that if at any future time it should be desired to operate the locomotive on this voltage, the pairs of motors can be changed from parallel to series connections and the same speeds and control combinations obtained as on 600 volts.

These locomotives have greater capacity and higher efficiency than any other high speed electric locomotive ever constructed, while at the same time having lower total weight, weight per driving axle and dead weight than any other locomotive of similar capacity.

**RAILWAY CONSTRUCTION IN THE CONGO.**—It is reported that the preliminary work for the extension of the Elizabethville-Kamboye Railway toward Bukama is now being undertaken, and that 60 miles of the new line are expected to be completed by next March. The Lower Congo-Katanga Railway, which will be 1,100 miles long, is now being surveyed, and on completion of the survey the construction work will be started. It is proposed to join the Cape to Cairo line at Bukama. The Congo-Tanganika Railway from Kabalo to the lake is approaching completion, and only about 60 miles, for which a portion of the grading has been finished, have now to be built.

## NATIONAL ASSOCIATION OF RAILWAY COMMISSIONERS.

The twenty-fifth annual convention of the National Association of Railway Commissioners was held at Washington, D. C., in the hearing room of the Interstate Commerce Commission, October 28-31. President O. P. Gothlin, formerly of the Ohio commission, presided. Chairman E. E. Clark of the Interstate Commerce Commission delivered an address of welcome, which was published in last week's issue of the *Railway Age Gazette*.

In his address as president, Mr. Gothlin expressed the opinion that the association is not accomplishing as much as its opportunities would seem to warrant, for the reason that the members depend too much upon the committees, who present excellent reports which are not followed by action, and that these reports are frequently the work of the chairman alone. President Gothlin also suggested as a means for relieving the congested condition of the Interstate Commerce Commission's docket, that the country be divided into six districts, with a commissioner in charge of each district, the seventh commissioner to handle complaints arising from transportation involving overlapping jurisdictions.

He also took the position that regulation has done more for the railroads than for the public, and protested that no railroad, legislature or court has any right to allow higher rates to be charged at intermediate points, or non-competitive points, than at other points. He urged state commissioners to take more interest in the complaints of all shippers, even though concerning interstate commerce, and suggested that formal complaints should be abolished and that commissions hear ex parte complaints, assuming the burden of prosecuting the cases.

Commissioner C. C. McChord, of the Interstate Commerce Commission, presented the report of the Committee on Amendment of the Act to Regulate Commerce, recommending a change in section 16, to provide that complaints asking for reparation may be filed with the commission within three years, instead of two years, from the time the cause of action accrues, and also an amendment to provide that failure to post contemplated rates at the time proposed tariffs are filed with the commission shall prevent the new rates becoming effective. This was recommended on the ground that the shipping public now receives no actual notice of a change in rates until it takes effect. Chairman Clark suggested that carriers be penalized for failure to post tariffs at every station.

Clyde B. Aitchison of the Oregon commission, presented the report of the Committee on Delays Attendant upon the Enforcement of Orders of Railway Commissioners, outlining various methods for the elimination of delays, and concluding with the recommendation that the committee be abolished and its work be transferred to the Committee on Legislation. After reference to the executive committee this suggestion was adopted.

Martin S. Decker, of the New York Public Service Commission, Second district, presented the report of the Committee on Express Service and Express Rates. After emphasizing the importance of the work done by the Interstate Commerce Commission in the regulation of express matters the report suggested the need for a committee to consist of one representative from each of the state commissions, representatives of the Interstate Commerce Commission, and of the express companies to try to arrive at some working basis for the uniform adjustment of intrastate rates. The association voted to appoint a committee representing the various commissions to formulate a uniform method of stating intrastate rates.

Charles Elmquist of the Minnesota Commission presented the report of the Committee on Grade Crossings and Trespassing on Railroads, suggesting that there is more need for action than for the presentation of views. A member called attention to the campaign to bring about the enforcement of laws against trespassing now being carried on by the New York Central in New York, where thousands of arrests are being made weekly.

William Kilpatrick, secretary of the Illinois Railroad and



Warehouse Commission, and chairman of the Committee on Safety Appliances, said the committee had not had a meeting. He presented an individual discussion saying it is of vastly more importance to take steps to avert collisions and derailments than to provide steel cars to mitigate their results. He also referred to the need for the enforcement of laws to prevent trespassing, quoting statistics on the subject prepared by R. C. Richards, and declared that the most crying need at the present time is for the control of trains by an absolute space limit carefully defined by block signals, and rigidly enforced, and if necessary, further protected by an automatic train stop.

Lawton T. Hemans of the Michigan commission, presented an individual report as chairman of the Committee on Legislation, in which he said: "While there is an urgent demand on the part of the railroads that they be subjected to the regulation of one federal body and freed from the regulations emanating from 48 state bodies, still both will unquestionably remain, each satisfying a need born in the very nature of things. The legislative need of the present is the elimination of the needless, valueless, and we may say senseless conflict that exists between the states and the federal authority upon kindred phases of interstate and intrastate commerce." He recommended that appropriate action be taken by the association empowering the Committee on Legislation to confer with the Commissioners on Uniform State Laws at their next annual meeting, to the end that there may be brought about a basis of co-operation in the preparation and support of legislation affecting commerce and transportation within the various states.

On Wednesday morning, L. B. Finn, of the Kentucky commission, delivered an address on the Minnesota rate case decision, in which he vigorously opposed the idea that the federal government has power to regulate intrastate rates as soon as congress sees fit to exercise the power. He argued that it would be inexpedient to burden the federal government or the Interstate Commerce Commission with the additional duty of regulating state rates, and also discussed the legal questions at length, saying that the constitution means what the Supreme Court says it means and that the interpretation of the court is subject to change in accordance with changes in public sentiment.

John M. Eshleman, of the California commission, presented the report of the Committee on Railway Capitalization, 110 printed pages, which included a review of the various state laws dealing with railway capitalization and a large number of letters from state commissioners as to the practical working of the laws. The recommendations of the committee are summarized as follows:

We do not believe it necessary for the purposes of this paper to recommend any particular form of an act, but we do believe that we should recommend the minimum which should be provided, and this minimum we believe should be the following:

1. The limitation in the act of the purposes for which the issue of stocks and bonds shall be permitted.
2. Authority to the commissions to see to it that the proceeds of the sales of stocks and bonds are devoted to the purposes for which they are issued.
3. No stocks or bonds to be issued without the positive approval of the commission, or at least a veto power should be reposed in the commission similar to the power which the Interstate Commerce Commission has to suspend rates. If this method is pursued, the same full investigation should be required on the part of the commission in every instance, as is required when the affirmative action of the commission is provided for.
4. No limitation in the statute as to the amount for which either stocks or bonds shall be sold.
5. The power shall be reposed in the commission to impose conditions and to grant the application of the utility, either in accordance with such application or in lesser or greater amount, and to impose such other conditions as the commission shall deem necessary.
6. Regulation of the stocks and bonds of interstate common carriers to be delegated to the Interstate Commerce Commission.

Basing our recommendation upon the foregoing conclusion, your committee respectfully recommends:

That Congress immediately pass an act empowering the Interstate Commerce Commission to regulate the stocks and bonds of interstate carriers in the manner and to the extent hereinbefore outlined.

In conclusion, your committee desires to impress upon the members of this association the tremendous importance of the matter we have been here considering. The regulation of the securities of utilities, other than

interstate carriers, is being handled with increasing efficiency by the various states from year to year, and the beneficial results flowing therefrom are being recognized, not only by the public as patrons of these utilities, but by the utilities themselves. In those states where most adequate regulation is now being provided, money is being invested in increasing amounts and the stability of securities is being established and healthy financial conditions are being brought about. In substantiation of this conclusion, we respectfully invite your attention to those states wherein the commissions have been given adequate and plenary authority to deal with this subject, and suggest that the members of this association consult with the representatives of the utilities from such states in the belief that such representatives will bear out the statement herein contained that from the viewpoint of the honest public utility, honest, adequate and intelligent regulation is a good thing.

In the case of the interstate carrier, however, by reason of the facts hereinbefore referred to, it is possible for the various states to regulate, and the federal government should not lag behind in this field wherein it alone is competent to act.

Most of the Wednesday afternoon session was devoted to a discussion of the report on capitalization, at the conclusion of which the recommendations were endorsed by the association with the exception of the fourth, providing for "no limitation as to the amount for which stock or bonds shall be sold."

On Thursday, Milo R. Maltbie, of New York, presented the report of the Committee on Railroad Taxes and Plans for Ascertaining the Fair Valuation of Railroad Property. This consisted of a series of special papers as follows:

A Just and Scientific Basis for the Establishment of Public Utility Rates, with Particular Attention to Land Values, by Commissioner Max Thelen of California. Discussed by Commissioner Clifford Thorne of Iowa.

Elements of Appreciation in Railroad Valuations, by Commissioner George A. Henshaw of Oklahoma.

Accounting Side of Rate Making, by Dr. E. W. Bemis of Chicago. Discussed by Commissioner R. Hudson Burr of Florida.

Depreciation and Its Relation to Fair Value, by Dr. A. F. Weber, Chief Statistician of New York, Public Service Commission, First District.

Valuation of Property Constructed from Surplus Earnings, by Commissioner Forest E. Barker of Massachusetts. Discussed by Commissioner W. M. Daniels of New Jersey.

On motion of Commissioner Thorne of Iowa a resolution was adopted providing for the appointment by the president of the association of a committee of 15 to co-operate with the Interstate Commerce Commission in making the valuation of railway property.

Mr. Klapp, of the Wisconsin Demurrage Bureau, presented a paper on Demurrage as a Measure of Relief from Car Shortage, in which he showed that car capacity has increased 69.22 per cent., locomotive tractive power 109.5 per cent., and ton-miles only 28 per cent. He suggested that increased terminal facilities have offered greater opportunity for storage by the shippers rather than assisted prompt unloading and that relief can be found in higher demurrage rates which will make it more economical for the business man to store his own goods than to pay the carrier for doing it for him.

B. H. Meyer, of the Interstate Commerce Commission, presented the report of the Committee on Statistics and Accounts, urging that greater attention be devoted by the railways to the assignment of expenses as between freight and passenger service. The report stated that so many roads are now assigning many of their expenses that it would seem to be possible to obtain far more accurate cost data than are now available. In discussing the paper Commissioner Clark said there is urgent necessity for the adoption of a uniform method of reporting loss and damage claims.

Clifford Thorne, of the Iowa commission, presented the report of the Committee on Uniform Classification and Simplification of Tariff Sheets, which, after reviewing the history of the agitation for uniform classification, concluded with a recommendation "that there should be appropriate legislation by congress, authorizing and directing the Interstate Commerce Commission, assisted by a body of disinterested experts appointed

by the commission, and paid by the federal government, to frame and promulgate a classification of freight to apply uniformly over the United States."

James E. Sage, of the New York (Second district) commission, presented the report of the Committee on Rails and Equipment, which included a general discussion of rails, speed recorders and steel cars, supplementary to the committee's report of last year.

The following officers were elected for the ensuing year: President, Lawrence B. Finn, of Kentucky; first vice-president, Clifford Thorne, of Iowa; second vice-president, Robert R. Prentis, of Virginia; secretary, William H. Connolly, Washington, D. C.; assistant secretary, William Kilpatrick, of Illinois.

The next convention will be held at Washington on November 17, 1914.

At the suggestion of Commissioner Marble the constitution was amended to make the Canadian Board of Railway Commissioners eligible to membership in the association.

## LEGISLATION AFFECTING THE TIME AND MANNER OF PAYMENT OF RAILROAD WAGES.

BY ARTHUR B. JONES,

Local Treasurer, Chicago & North Western Railway.

Various states of the Union have passed laws governing the time and manner of payment of employees, and various other states have had before their legislatures bills of like nature. I will endeavor to state the nature and extent of this legislation, passed or proposed; to indicate the cost to comply therewith; will state what I believe to be the reasons which brought on such legislation; will contend that these laws, instead of being in the interest of the employee, are detrimental to him, as well as to the companies; and will make a plea for an earnest effort to stop their spread and to abolish the laws already passed.

The fashion started in the East, some New England states having had such laws for some years; other eastern states, including New York, having had them for six years. During the last legislative sessions they spread through Pennsylvania, Ohio, Indiana, Michigan and Illinois. Very few states west of Chicago have such laws, but bills have been introduced in many of their legislatures, more of them this year than ever before, but, with the exception of Illinois and Michigan, none were passed.

Some of the laws govern not only the time of payment, but prescribe that payment be made in currency. Some require two payments, others four payments, a month, and as early as 10 days after the close of the period, while others allow as much as 18 days. Bills that failed of passage varied much; some requiring currency payments, some payment by bearer check and within three days after the close of the period.

The financial burden to railway companies in complying with such legislation is of much interest to railway managers and owners. The cost to keep the time, compute the wages and pay a railway employee once a month by check (the cost in currency is considerably larger) is approximately 20 cents, and to pay him twice a month, the cost, while not double, is increased by 60 per cent., or 12 cents. This means that the cost to the railroads of the State of Illinois, due to the recently passed law, runs to a total of \$220,000 per year, and if the law spreads only to the northwestern states, traversed by the lines of the company I represent, the increased annual cost to the roads operating in those states will total \$700,000. If applied to the whole country, it totals \$2,125,000 a year.

The above does not cover many indirect costs, hardly ascertainable, but just as real nevertheless—such as the distribution of checks; the loss of the company's time in the employees procuring their checks, and the cashing of them, together with the

labor of agents in cashing large numbers of them; and the risk of other losses which always accompany cash transactions. Pay-day breaks into the routine and efficiency of all, not only at the time of disbursement, but in all things directly or indirectly affecting the payrolls. Operating officers must necessarily give much attention to matters concerning the payment of wages, and this impairment of their efficiency should be sufficient in itself to defeat such bills.

Like many such laws, these are much more far-reaching than the objects which they presumably seek to effect, for they involve the upsetting of economic practices, commercial and domestic, which experience has proven to be sound and to most nearly meet the requirements of all.

The amount a railway expends for labor forms such a large part of its total disbursements that the duty of paying the large forces, scattered, moving about, working under different departments and with varying rates, rules and conditions, is one of great responsibility and harassment. To compute the time and determine each man's due and pay him, is only accomplished through a carefully devised system—the result of years of practical experience. It is designed to secure for the employee all he has earned and to protect the companies against loss. Few of the problems enumerated above enter into wage disbursements as applied to other lines of business, and this fact furnishes a valid reason why railways should not be included in such legislation, if, indeed, any legislation on the subject is desirable.

Notwithstanding the cost, direct and indirect, such legislation might be wise if it brought the employee a single benefit. On the contrary, however, the country over, practically all obligations are adjusted to a monthly settlement, and, therefore, the monthly payment of wage more nearly meets the requirements of employees, for their obligations, such as rents, store bills, etc., mature monthly, and this enables them and their families to effect the settlement of their debts at one time. The more one studies the effects of such laws, the more he is impressed with their harmfulness to employees, for they enter vitally into the home economy and affairs. Being paid so often, little is owing to the employees at any time, and the basis for the establishing of a financial credit is therefore impaired. Many go from hand to mouth, trusted by nobody, some demoralized, being required, in order to pay monthly accounts, such as rents, to husband their money until such accounts are due—a difficult task for anyone. The frequent payment promotes improvidence, and those who are extravagant and inclined to wrong-doing might follow their bent with greater ease, being harmed financially and morally. I am assured by a number of large employers of men operating in various parts of our country that nowhere is it so difficult to get competent and reliable men as in those states where as many as four payments a month are required by law.

The essential things are that the employee knows exactly when payment will be made, and that it be made as early after the close of the month as is practicable. Railway payments never vary a day from month to month, and the employees can confidently look forward to a particular day when their pay will be received, and enable them to cancel their obligations and add to their savings. Railroad men of all classes, because of the certainty and regularity of their pay, have less trouble than others in getting credit for the needs of life, and, moreover, the railways' general practice is to honor hotel and boarding-house bills when necessary to employees. Discharged men are paid promptly upon leaving the work, and payments are made in advance in cases of sickness, death or other emergencies, no employee being compelled to suffer in the slightest degree because he cannot get his money oftener than once a month.

While we may not all agree as to the relative merits of payment in currency and payment by check, we will agree that those companies which find that payment by check more nearly meets the circumstances which surround them should not be arbitrarily required to change. The subject of currency payments, as against the check system, is a large one, and as I see

it, there is much to be said against currency, both from the standpoints of expense and risk, but our company follows both systems, for we find conditions, even on our own lines, vary enough to dictate this, and this strengthens my conviction that railway officers should be left free to solve such problems by applying their own ample experience and commercial prudence.

It is understood that the earliest of these laws, as for instance in New York, were suggested by the tradesmen, hoping that it would enable prompter payment of accounts by employees, which hopes, by the way, have not been realized, but, on the contrary, the opposite effect has been experienced. It will be noted that the laws spread from one state to its neighbor, and this is due to the fact that, as operating divisions overlap from one state to another, employees receiving their pay once a month feared they were losing an advantage that those in the next state enjoyed.

I have faith, however, in our ability to prevent the spread of this wage-payment legislation, and it is pinned to my belief that the employees, at least in our northwestern district, will never again send representatives to the legislatures for such legislation, as they will realize that no benefit comes to them, and that the large cost, coming from the treasuries of their own companies, will, to just that extent, lessen the ability of their companies to spend money in ways that really benefit them. I believe that they are beginning to see the lack of wisdom of advocating legislation of any kind that is burdensome and detrimental to the interests of their companies; that they realize that the interests of the employees are wrapped up in the success of the companies; and that any move which hurts the companies hurts them. During the next two years I hope that there will be collected such data as actual experience brings forth, to aid in proving that an often payment of wages is unwise for all concerned.

**THE NEED FOR HIGHER RATES.\***

By B. A. WORTHINGTON,  
President, Chicago & Alton.

In the early summer months of the prevailing commercial activity, an imminent danger was sighted; and a note of warning was sounded. Weaknesses were evident in the financial structure supporting the railroad situation. What have we done to remedy this condition? Nothing! Have we lightened the load which commerce shall carry over this structure? No, that is a practical impossibility! Have we used common business prudence in ignoring these conditions? How long may we expect to maintain the poise of commercial supremacy, standing upon unstable fundamental conditions, eagerly reaching for the greater load so temptingly offered by progress and advancement?

The weakness of the future is the weakness of today, and it is a crime against reason to ignore it. And while expressions of sympathy are offered and are accepted in good faith, more substantial and enduring support is necessary. Our physical ailment does not respond to Christian Science treatment, and the quackery of legislation is nauseating.

No better evidence of the decline in railroad prosperity can be adduced than the comparative composite statement of the income accounts of a number of important common carriers in the state of Illinois, including the Wabash, Chicago & Eastern Illinois, Big Four, Illinois Central, Chicago, Peoria & St. Louis, Toledo, Peoria & Western, Lake Erie & Western, Toledo, St. Louis & Western, Cincinnati, Hamilton & Dayton, Vandalia, Peoria &

Eastern, Chicago, Terre Haute & South Eastern, Chicago, Indiana & Southern, and Chicago & Alton; fourteen railroad systems invaluable to commerce as agencies of concentration and distribution, particularly to the State of Illinois, more particularly to the Central Manufacturing District of Chicago.

The year 1908 was a panic year. The year 1907 and other years prior to 1908 were better than 1908.

Net after taxes in 1912 and 1913 were smaller than in any previous years.

Taxes increased \$1,000,000 from 1911 to 1913.

Net corporate income, after deductions, shows that these fourteen railroads had \$16,155,624 to apply to dividends in 1910; only \$4,193,877 in 1912; and only \$4,753,493 in 1913.

Net corporate income shows a decrease of 56.2 per cent. since 1908; in other words, decreasing twice as rapidly as total operating revenues are increasing; i. e.:

Total operating revenues.....	increased 28.3 per cent.
Net corporate income.....	decreased 56.2 per cent.

Deductions from income have increased due to an increase of almost \$130,000,000 in new capital put into additions and betterments, and to the increase in rates of interest which the railroads have to pay.

In dealing with the matter of railroad regulation, more particularly with the matter of rate limitations, it is customary with commissions and legislatures to attach marked significance to the continually increasing gross earnings of the railroads, the inference being that gross earnings constitute a fairly reliable index to the financial results of operation.

Not only is this theory entirely wrong, but the premises upon which it is based are unsound. Not only has revenue per unit of service decreased very rapidly in recent years, but expenses have increased in even greater ratio—a two-edged sword that destroys the theory of gross earnings representing an accurate barometer of railroad prosperity.

To illustrate concretely what this means in dollars and cents, I have only to cite the current earnings of three of the greatest railroad systems in the world—the New York Central Lines, the Pennsylvania System, and the Southern Pacific Company.

The July statement of earnings and expenses of the New York Central Lines, recently published, shows:

Total operating revenues.....	increased \$2,328,988—10 per cent.
Total operating expenses.....	increased 3,239,970—19 per cent.
Net operating revenues.....	decreased \$910,982—15 per cent.

For the same month the Pennsylvania System published the following statement:

Total operating revenues.....	increased \$1,995,053— 6 per cent.
Total operating expenses and taxes.....	increased 2,727,745—19 per cent.
Net operating income.....	decreased \$732,745— 8 per cent.

And the Southern Pacific Company reports:

Gross revenue .....	decreased \$1,380—1-100 per cent.
Operating expenses and taxes.....	increased 784,803—14 per cent.
Revenue over expenses and taxes.....	decreased \$786,183—19 per cent.

Here are two instances wherein total operating revenues increased very substantially, but net decreased in a much greater ratio; in the latter instance, with approximately the same gross revenue, an alarming decrease in net after deducting operating expenses and taxes, is shown.

I call your particular attention to the fact that these are the current results of operation of three of the foremost and most progressive railroads in America, at the present time enjoying the heaviest volume of traffic in their histories. And, incidentally, I venture the question—what can be expected of the weaker lines? And what may be expected of even these strong lines themselves in a period of adversity which is sure to come and which, in its very nature, will take away the remedy now at hand?

While these figures in themselves are convincing that gross earnings do not constitute a reliable index to the financial results of operation of railroad properties, as you are aware they do not include fixed charges; the higher rates of interest now demanded on railroad bonds and notes; and the prohibitive rates for new capital necessary for improvements to handle

	Fiscal Years.		Increase or Decrease.	Per Ct.
	1908.	1913.		
Operating revenues.....	\$160,664,617	\$206,172,785	Inc. \$45,508,168	28.3
Operating expenses.....	118,257,987	162,078,777	Inc. 43,820,790	37.0
Net operating revenues..	42,406,630	44,094,008	Inc. 1,687,378	4.0
Operating ratio.....	73.6 per cent.	78.6 per cent.	.....	.....
Taxes .....	\$5,705,564	\$7,940,289	Inc. 2,234,725	29.1
Net corporate income...	10,843,704	4,753,493	Dec. 6,090,211	56.2

\*Extract from a recent address before the Central Manufacturing District Club of Chicago.

economically the volume of traffic that is now moving, and the prospective traffic of the future, are factors which will influence the results of operation for years to come.

You will all remember the panic year of 1908, following the exceptionally prosperous business year of 1907; and as business depression is likely to come upon us at any time in this country under present business methods, it occurred to me that it might be interesting for you to note what would have been the effect, had the year 1913, following the fairly good business year 1912, suffered a business depression corresponding with the depression of 1908. By applying to the results of operation in the year 1912, the same ratios of decreases as in 1908 compared with 1907, eleven important railroads operating in the central west would show the following decreases in 1913:

Total operating revenues.....	decrease	\$28,091,581—	5.2 per cent.
Total operating expenses.....	decrease	6,992,276—	1.8 per cent.
Net operating revenues.....	decrease	\$21,099,305—	34.6 per cent.

Considering the railroads included in the foregoing comparison individually, four of the lines would show deficits in net corporate income ranging from \$300,000 to \$3,850,000; three of the lines would show comparatively small margins of surplus under net corporate income, ranging from \$336,000 to \$682,000; there being only four of the larger and stronger railway systems that would be able to maintain a sufficient surplus to insure stable financial conditions, even during a depression of one year's duration, and a continuation of such adverse conditions would no doubt produce more disastrous results.

This takes no account of the continually increasing taxes and fixed charges; nor is there any substantial assurance at hand that a recurrence of the 1907 panic is impossible or even improbable. Apparently we have averted a panic this fall—or, have we only postponed it after all? Have we been treating the *cause* of the trouble, or only a *symptom*? Have we eradicated the cancer or have we only chloroformed the patient?

Time will tell—time is telling.

It is extremely urgent that commerce should recognize these conditions and display some activity to relieve the situation. Kind words of sympathy are not out of place at a funeral, but sympathy is a poor substitute for nourishment; and what the railroads need now is nourishment—in the shape of increased freight rates and it is up to the manufacturing interests of Chicago, as a matter of self-defense, to take the lead in fighting for this cause.

The disregard and contempt displayed by the makers of our laws for the knowledge and experience of thousands of trained experts in railroad matters, and the extravagant recklessness and utter foolishness in tampering with the most delicate and evenly balanced machinery of commerce, are serious matters which call for prompt and heroic treatment, and nothing can be as effective as a serious, conscientious and persistent protest on the part of the shipping interests of the central manufacturing disliberally discounted in legislative matters, the railroads are at the mercy of an unsympathetic public, bound and gagged with legislation and plucked to a finish by the harpies of politics.

In this connection it might be well to look back to the early days of railroading—wherever we may look we find the railroads nursing industry, defending industry with every means at their command—lawful or unlawful, the *railroads defended industry*, for the railroads always have recognized that industry is indispensable to successful railroad operation. In many instances, we find that the railroads donated building sites, and transported building materials, either free of charge or at a nominal cost. The old-time rate wars, destructive to the railroads themselves, were sacrifices to industry.

The acute business instincts which prompted the railroads to accept the dangers incident to their pioneering work of development, were always sounding the future. The railroads anchored their lines with industries and pushed on farther and farther into the wilderness, always looking to the future for reward. Profits, so called, lay far beyond the span of life of the great men who undertook this hazardous work in the interest of

civilization; they responded to a mightier cause, and bequeathed to us the legacy of their efforts—the railroads and the industries which the railroads have encouraged and protected always—the elements of peace, happiness and contentment. However, changed business conditions have come about—purely and simply through the efforts of the railroads to protect industry.

Discrimination, manifestly an unfair instrument of protection but a perfectly natural weapon in the early pioneering days, has been condemned; discretion is indicted and held as an accomplice. The fine economic poise of commercial conditions, ever changing and shifting to meet the varying needs of industry, hitherto has been established automatically by freight rates which maintained more or less definitely a perfectly natural balance in commercial relations. In the nature of things this compensating influence, the most delicate and perfect, withal the most potent regulating influence, cannot be fixed permanently and arbitrarily without immediately disrupting and finally wrecking the entire machinery of commerce itself. We are straining here and there, some pieces of this vast machinery already are broken, and it is the sheerest nonsense imaginable to further withhold the relief that is now within our hands. A recurrence of the panicky conditions of 1907 or a serious stringency in the money market under present conditions, without doubt, would remove the remedy forever.

With the public clamoring for steel passenger train equipment, the government heading the procession with mandatory orders for steel postal cars regardless of everything else; the public still further demanding new, elaborate and exceedingly expensive passenger stations, not only at Chicago and Kansas City, but at many other points, none of which means additional revenue—only additional expense; also demanding and enforcing the elimination of grade crossings, and innumerable useless and impracticable “improvements”—it is a plain case of “money down and hands up” inconsistent with either justice or common sense.

Measured with the hazards undertaken and the industrial development induced, railroad securities should be free from disturbing influences of this kind. By all means railroad bonds should be as safe investment as government bonds, for the physical property of the railroads constitutes the underlying value of government bonds. It is a parody on business methods to tamper with a security of this kind. Withdraw the railroads, and all that they imply, and government bonds would represent an entirely fictitious value, a wealth of the nation that would be wealth unavailable. And to the extent that these artificial measures are restricting railroad development, we *are* withdrawing the railroads as a tangible security of national prosperity.

In 1910, 33.29 per cent. of the stocks of railroads operated in the United States had never paid a dividend, yet these railroads are invaluable to the thousands upon thousands of persons they serve. Surely there is no sound reason for making the conditions of operation so onerous and burdensome as to crowd out many of these lines serving territory where traffic is light. Every one of these lines should be protected, should be enabled to maintain the physical condition of such property at a high standard of efficiency, yield to capital invested in such stocks a fair return commensurate with the hazards undertaken and development created, and, further, to provide from operation a surplus to guard against reverses of the future.

Railroad stocks, however, are delivered by legislative enactment to the tender mercies of the pirates of labor and the sharks of finance—weather vanes of speculative sentiment, responding to the hot breath of summer and the cold blasts of winter. Railroad capital is reduced to a beggar at the doors of justice.

All this is arbitrary, unnatural and fraught with grave dangers. With reasonable rates for service performed (which is all that is asked, and all that is wanted), railroad property could be maintained at a high standard of efficiency, railroad securities no longer would be financial traps in the hands of wily speculators, but savings banks—anchors of the nation, and the impetus to industry that would be afforded by permitting the railroads to supply current necessities, would be nothing short of wonderful.

# LOCOMOTIVE FUEL ECONOMY ON THE FRISCO.\*

Systematic Attention Given This Important Subject and Cooperation Emphasized as Necessary to Obtain Results.

By ROBERT COLLETT,

Superintendent of Locomotive Fuel Service, Frisco Lines.

During 1912 there were 236,444 miles of railroads in the United States and the cost of fuel for operating trains over them was \$230,555,544, or 11.85 per cent. of the total operating cost, and 8.22 per cent. of the gross earnings; a cost of about 4,000 per year for each locomotive in service. In the past two years there has been a considerable increase in the unit cost of fuel, and this has further increased the ratio of fuel expense to the gross earnings. Railroad managers are therefore very much interested in keeping the cost to the lowest possible figure; and when purchasing new locomotives or overhauling engines in service, consideration is given to equipping them for the greatest economy in the use of fuel. Appliances of whatever nature, unless properly looked after, do not produce results, and it, therefore, resolves itself largely into the matter of the human element. A crew should not be sent out in charge of a \$20,000 locomotive with \$30 or \$40 worth of coal in the tank, and access to that much more, if required on the trip, without feeling a personal responsibility in the care of the engine and supplies, and there should be some way of determining whether or not proper efficiency is obtained.

1911 it was in effect on all divisions. A record is kept by charging the amount of fuel used by each engine in moving over the division on each trip against the gross ton miles in freight service, and passenger car miles in passenger service, for that particular trip, the work being entirely independent of the fuel department or mechanical department. The result of the effort made in the direction of fuel economy on the St. Louis & San Francisco in passenger and freight service for the calendar years 1911 and 1912, compared with 1910, is shown in the attached statement. This statement is predicated on the pounds of fuel used per 1,000 gross ton miles in freight service and pounds per passenger car mile in passenger service—the accumulative saving is figured on cost of fuel exclusive of cost of transporting it over our own lines; neither does it include the expense of handling, and does not include switch and work service. This statement was made primarily to show the enginemen and all others concerned the progress that was being made. Necessarily any saving in the volume of fuel used will reflect a further decrease in operating costs incident to the smaller volume of company material (which

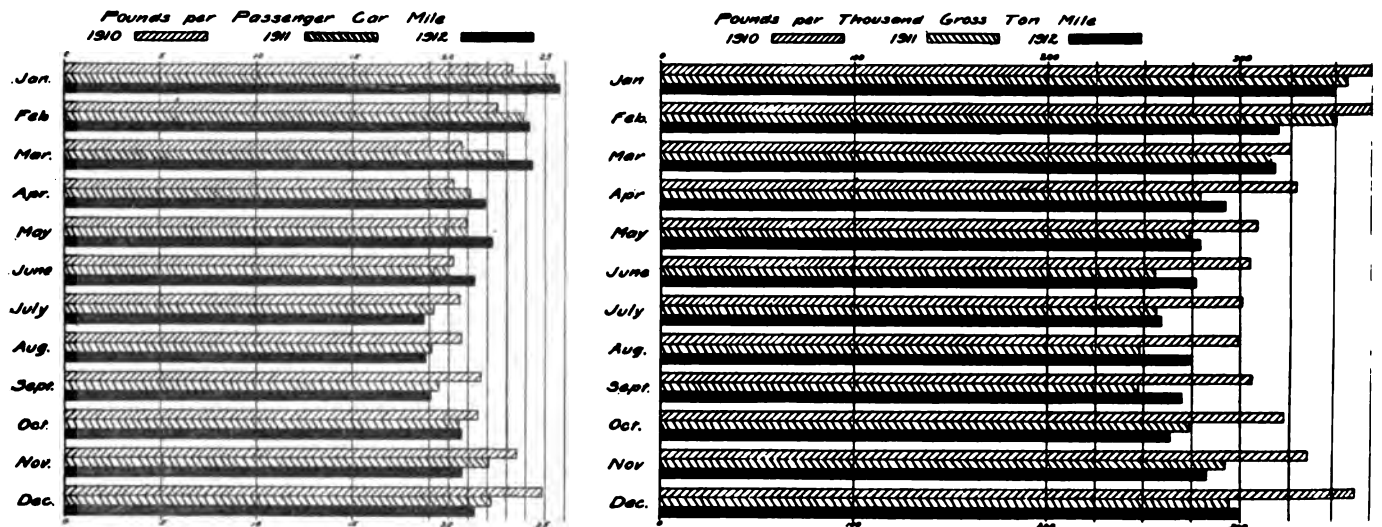

Fuel Used per Passenger Car Mile in Passenger Service and per 1000 Gross Ton-Mile in Freight Service.

At the close of the year 1910, a plan was originated by W. C. Nixon, vice-president in charge of operation of the Frisco Lines, to look into the matter of locomotive fuel economy. Briefly, the plan was to undertake to find out what we were doing in the use of locomotive fuel and what we might reasonably expect to do and how to do it. Some of the items given special emphasis by Mr. Nixon were:

- Waste of fuel because of engines delayed on the road.
- Engines kept under steam unnecessarily at roundhouses.
- Improper handling of engines.
- Excessive use of fuel by firemen.
- Engines not in good condition.
- Fuel not up to contract specifications.
- Shortage of coal before reaching the pockets.
- Fuel used for other purposes and improperly charged to engine use.

Performance sheet to be made by engines, so that the result of each trip would be shown in a statement by days in order that an abnormal amount of fuel used on any one trip or day could be determined.

Any other matters that may require attention.

This plan was put into effect the latter part of December, 1910, and at first was confined to one division; by the close of the year

in this case is cars of company coal or oil) that must be moved without revenue return.

The very severe winter and its effect on the motive power and the road bed, the Mississippi valley floods in the spring and the suspension of the mines, with necessity for storing coal on our line, made 1912 scarcely a comparative year with 1911. In January, February and March, 1912, the Mississippi valley in particular experienced several severe snow blockades. How this affected the operation of trains is evidenced to some extent by the double-head mileage necessary to keep passenger trains running. In the three months mentioned the St. Louis & San Francisco ran 70,401 miles of double-headed passenger trains as compared with 19,129 miles in the same three months of 1911, an increase of 51,272 miles.

The theory of the Frisco fuel service is to get away from the report of the individual crews, because it is believed that such reports frequently result in sharp practice and may not reflect true conditions, whereas, if a report for engines is made and an engine is not in proper condition, it remains for the mechanical department to correct the defects; if due to improper operation on the part of the crew, it is for the division officers to see that

\*Abstract of a paper presented before the St. Louis Railway Club at the May meeting.

they are properly instructed. Test trips were made by riding engines just as they were turned out for service, to determine the actual amount of fuel used, and although an engine might steam well, if it burned an unnecessary amount of fuel, the cause was investigated.

These trips showed the necessity for establishing standards of efficiency. An engine may show a very good performance from a train handling standpoint and still be making a very poor fuel performance. A great many tests have been made on every division, after having gone over the engines to see that all of the details that would affect the fuel performance were as nearly correct as possible, such as the condition of valves, cylinder packing, air admission through grate and ash pan, size of exhaust nozzle, size of injector, and in fact every feature that would improve the performance of the engine. Standards of fuel consumption have thus been established, and standards for draft arrangements for each class of engines have been decided on as being the most practical for the various operating conditions under which the engines work. The average performance of the engines in service will exceed the test figures, but the test figures show what the locomotive is capable of doing and furnish a standard to work to.

I will now take up the various items outlined above:

*"Waste of fuel by reason of unnecessary delay on the road."*

The fact that all concerned know that the management is closely observing the fuel cost, results in trainmen and enginemen calling attention to delays, and individual cases are followed up to prevent a recurrence.

*"Engines kept under steam an unnecessary length of time at*

He has been selected for the position because he is a skillful engineman. He derives benefit from observing the work of all the crews and should know the best methods of handling and firing the different classes of engines, and should be able to impart this information to others in such a way as to not give offense. He should possess a good disposition and at least two suits of overclothes, and if he is to obtain proper results in fuel economy he must have time to get out on the line with the crews. It is, of course, necessary to spend some time in the terminals, but his time should not be so taken up with other duties that he will not have ample time to follow the work of the crews on his division and also note the result of changes that have been made on the locomotive or appliances that have been put on which are intended to improve the performance of the engine. The assistant superintendent of locomotive fuel service, who formerly held the title of road foreman of equipment, is in charge of the fuel economy work on his division and is a member of the superintendent's staff. He is entirely independent of the fuel department or mechanical department, although, of course, his work is almost entirely in connection with the work of these departments. He watches the tonnage rating, to see that the engines get the most uniform loading possible, the maintenance of draft appliances in the condition found by tests to be the most efficient and economical, and conducts all of the progressive examinations of firemen and assists the master mechanic in looking after the general care of the engines and their operation by the engine crews.

In the management of the engine there are not a dozen different correct ways to run and fire it. There is one best way to handle

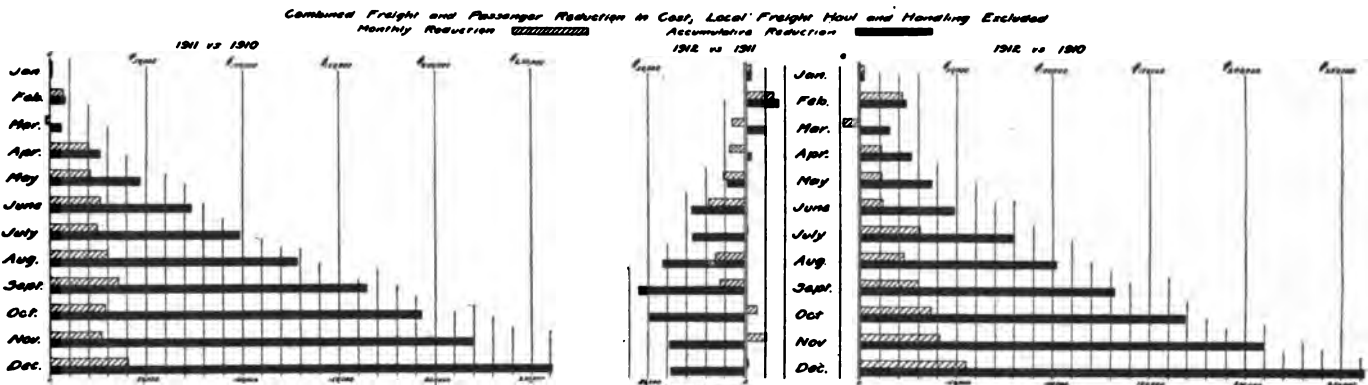

Showing Fuel Saving Accomplished on the Frisco During the Past Three Years.

the roundhouse." Lack of facilities will sometimes cause a waste of fuel in this respect. However, there is apt to be a tendency to put the burden of responsibility on the roundhouse foreman, requiring him to keep engines ready at all times. This was handled by establishing a rule that the transportation department will furnish the mechanical department three hours' notice before the engine will be required for service, and as nearly as practical this rule is observed.

A report is made showing how much fuel is burned at each terminal by engines standing under steam for more than three hours, and a statement of the cost is submitted to each division superintendent at the close of the month. On short divisions, in passenger service, the amount of fuel consumed at the terminals may easily equal 20 per cent. of the entire fuel used by the locomotives. On a number of divisions the passenger engines are now run over two freight divisions. At Newburg, Mo., an intermediate freight terminal located between Springfield and St. Louis, the fires are not cleaned on passenger engines; we simply clean the ash pan and bank the fire, the engine taking the next passenger train forward.

*"Excessive use of fuel by firemen and improper handling of engines."* Proper results in the management of engines can only be obtained by first-class team work on the part of engineers and firemen. Before commenting on the work of the crew, I wish to say something about the man who has supervision over the crews.

each class of engine, and he should know that way and let the others know it and ride with the crews often enough to know that they do their work in the proper manner.

The engineer who makes the best fuel performance pays particular attention to a number of things. He knows what the condition of the fire is when he pulls away from the terminal, and handles the engine accordingly. He does not slip the drivers if it can be avoided, or tear holes in the fire. He opens the cylinder cocks as soon as circumstances permit and relieves the condensation, thereby avoiding damage to the pistons or cylinders or of washing lubricants off the cylinder walls and valve seats. He starts the lubricator early enough to have the cylinders and valves well oiled before starting the train and feeds both sides alike and regularly. He does not change the reverse lever from full stroke to the final cut-off in one or two movements, but shortens the cut-off gradually as the speed increases and handles both the reverse lever and the throttle so that, especially on slide valve engines, the steam chest pressure does not back up into the oil pipes and retard lubrication. He works steam as expansively as consistent with good lubrication, schedule and general condition of the valve gear, and this without particular reference to the perpendicular position or angle of the reverse lever. The injector is handled so as not to over-supply the boiler with water, requiring that the injector be shut off on account of too much water, nor does he allow the fireman to do so when

he is pumping the engine. He understands the language of the locomotive and can feel its pulse without the necessity of a certain amount of noise at the stack, provided the engine will do its work without such noise. The running time is used between stations and the movement kept as continuous as possible. The result of his observations and opinions are responsible for the engines having been equipped with the present modern type of quadrant and reverse lever and throttle, as well as other devices that will permit of the engine being operated skillfully, and he utilizes them to the best possible advantage and at the completion of his trip reports the items that are needed to be done to maintain or improve the engine's efficiency. A careful crew, working together, can do more to establish a proper fuel performance than all the devices known.

*"The firemen's duties."* The first thing, of course, is to start firemen out right when employing them. Formerly, in putting on new firemen, we gave them a student letter, to be endorsed by three engineers with whom they had ridden. There was a tendency for them to ride with the engineers who they thought would endorse their letter, or firemen with whom they were acquainted, although these engineers and firemen might not be the most skillful men. We now tell the student firemen who to ride with, and before accepting service they are interviewed by the assistant superintendent of locomotive fuel service, who either approves or rejects their application.

We try to anticipate the need for firemen and to have desirable men in view of these positions.

For the men already in service, we have a first, second and third year's progressive examination. The knowledge gained through discussion and study is reflected in the work of the firemen. It is natural that a fireman, having told the instructor the proper way to fire an engine, will endeavor to carry out this practice.

In making trips over the divisions where the performance is particularly good, a record is made of the trip by the assistant superintendent of locomotive fuel service. A copy of this record is sent to the division superintendent and the crews are given credit for skillful operation. A copy of this letter and record of the trip is frequently attached to the personal record of the crew.

We try to impress on the firemen that we want them to do their work in the easiest way, which is by carefully preparing the fire at the terminals, firing light and often, and keeping the fire as clean as possible. The instructions to the fireman are made so that the engineer will be agreeable to them and have them carried out when we are not on the engine. At best, we can be with one crew only a small part of the time, and it is largely the personal pride they take in their work that counts. If one crew can handle a seven-car, all-steel passenger train over a division of 119 miles and not take water over the entire division; another crew handle a local passenger train of seven cars over a 286-mile division and only take water twice, with a tank of 7,000 gals. capacity; or another engineer and fireman with a freight engine handle 90 per cent. of the engine's potential rating and run 97 miles between water tank stops, it indicates that a first class fuel performance is being made and that the engine is in first class condition; that the work is less arduous for the fireman than if the opposite were true, and it further indicates that we should try to bring the other engines and crews as nearly as possible up to this standard of efficiency. I do not mean by this that they should necessarily make the same run between water tanks, but such performance shows that neither fuel nor water had been wasted.

*"Engines not in good condition."* One of the most important factors in fuel economy is the conditions of the engines. It is essential that draft appliances be maintained to standard; that is, as nearly as possible to what is found to be the correct dimensions for the different classes of engines, and if an engine does not steam freely, the trouble should be looked for elsewhere. If the engine burns a level fire and the proper location of petticoat pipe and draft sheet has been determined for this class of engine, there is very little gain by moving the petticoat pipe up or down, or

changing the draft sheet; there is more likely to be a leak in the steam pipes or the exhaust joints. The first thing to ascertain is whether the flues are thoroughly clean, and whether there are any holes in the grates around the grate bearing bars or dump grates, and if there is plenty of air opening in the ash pan. If these items are found to be correct, a water test should be put on the steam and exhaust pipes. A very prevalent cause for the waste of fuel is that of reducing the nozzles. The engineer may report on the work book "Reduce nozzle; engine is not hard enough on fire." This is sometimes done at the suggestion of the fireman after the fire has become clinkered. There may be several causes entirely apart from the nozzle, such as the flues leaking or stopped up, the netting stopped up, a leak in the firebox or smoke arch, improper running or firing, or a number of other causes, and with the defect remedied, there would be no necessity for reducing the nozzle. But if nozzles are allowed to be reduced indiscriminately, it is probable that some other defects at least may not be corrected. The contracting of the nozzle calls for a heavier fire to be carried on the engine than on other engines of the same class and may result in the fireman firing engines that have not had the nozzle reduced, heavier than is required, with the result that another fire is spoiled and another engine is reported not steaming. We record the size of the nozzles on the monthly engine condition report. In the roundhouse we keep a board, slotted so as to straddle the bridge, and we put this down in the nozzle without opening the front end and thus check the actual measurements with the measurements reported.

Tests conducted by the Santa Fe show that engines equipped with a nozzle as large as is used on the average railroad have a back pressure in the cylinders, at times, equal to the pull at the draw-bar, which means that as much of the power of the locomotive is used in creating draft under these conditions as is used in pulling the train. From this the premium that is paid for contracting nozzles unnecessarily, or neglecting to clean them out, is readily seen; this feature should not be left to the discretion of some one in the roundhouse that would prefer to contract the nozzles rather than go after the real cause of the trouble. With us the nozzles are not reduced without the consent of the master mechanic and assistant superintendent of locomotive fuel service.

Another cause for the waste of fuel lies in valves so set that engines cannot be worked with the most economical cut-off. We found this was especially apt to occur on large freight engines equipped with slide valves. Unless this is specialized on and tests are made to show the difference in the fuel consumption of an engine working at a long stroke, or in close cut-off, the shops may not be particular to set valves so that the engines can be worked properly. On one division it was found by marking the cut-off on the quadrant, that the minimum point at which the engine could be worked was frequently not closer than 11 in. or 12 in. on slide valve engines having 22 in. x 30 in. cylinders. The valves were then squared up to work at any point of cut-off and it was found that the 5-in. notch was the most desirable minimum cut-off for this class engine. Quadrants have been similarly stenciled on one or two engines of nearly every class.

Our mechanical people try to make things as convenient as they can on the engines and are very appreciative of suggestions. Enginemen themselves are continually making suggestions that help the fuel performance, and we try to carry them out whenever practical.

*"Fuel not up to contract grade."* The assistant superintendents of locomotive fuel service inform themselves as to the contract grade of fuel used on their divisions and learn something of the accounting of fuel. They occasionally visit the mines and notice the quality of the coal as it is loaded. Our fuel department maintains a very close inspection at the mines on the quality of coal and distributes it to burn one grade of fuel on each division where it is possible to do so. Since the fuel economy department was established, we have made tests and certain changes in the distribution with good results.

*"Shortage of coal reaching pockets."* Aside from pilfering.

or coal that may be taken for cabooses from the cars of coal intended for locomotive use (and which has always been provided for by the fuel department by charging to each caboose in service an amount shown by test to be approximately correct, crediting locomotives with this amount), this is simply a matter of securing correct weights and is closely looked after by our weighing bureau and the fuel department.

*"Fuel used for other purposes and improperly charged to engine use."* This item refers to the incorrect distribution of fuel primarily charged to locomotives, but which is diverted at round-houses, shops and elsewhere for miscellaneous purposes.

A careful canvass of such divertments was made over the entire line and steps taken to see that the proper transportation, roadway or shop account was charged with the fuel consumed by it, and proper credit, in return, given the open fuel account, thus relieving the locomotives of a miscellaneous tonnage that they did not consume. While such mischarging did not occur on our lines to any material extent, unless watched continuously, a mis-handling of this character is liable to creep in with resultant disadvantage to the locomotive fuel performance.

By co-operating with the fuel and special service departments we have practically overcome the pilfering of coal. This is a public evil that is probably not thoroughly appreciated. We should try to disabuse the mind of the trespassing public of the idea that coal in transit or standing in railroad yards or even on the ground at coaling stations is nobody's or everybody's property. This applies to commercial as well as to railroad shipments.

To establish a proper fuel performance sheet, much depends upon the correctness of the daily coal report furnished from the coaling stations. This is apt to be lost sight of. It is a simple report to make out, but it is very necessary that close attention be given it to secure accurate figures, representing the actual amount of coal given to each engine. When visiting terminals, the assistant superintendents of locomotive fuel service check up a great many things from a fuel standpoint and give special attention to the end that engines are charged with the exact amount of coal they receive.

It is very important also that engineers familiarize themselves with the amount of fuel required to fill a tank and make out tickets for the exact amount ordered, for in the event of taking coal from connecting lines or mine tipples on the line, the engineers are, in a way, the purchasing agents of the company they represent.

We feel that we gain a great deal by making a daily performance sheet. While varying conditions will cause engines to burn more fuel one trip than another, even though the hours of service may be practically the same, the most important point of daily entries is that it affords an opportunity to locate errors in fuel distribution or to check one engine against another in the same class of service, and which could not be discovered in any other way. It is of no advantage to compare one division with another, or one road with another. The only true comparison is, as before stated, to find out what it is possible to do in each class of service and establish that as a standard to work to. Another point in favor of the daily record is that division officers learn more concerning the items that affect the fuel cost per car mile and per 1,000 gross ton miles, such as terminal consumption, light engine movement, double-heading, delays on line and many other things. Due to so many different items affecting fuel consumption, it is difficult to explain fuel increases 30 to 60 days after the fuel is consumed without some data being kept during the time the fuel is being used. Post-mortem examinations are scientifically useful in a general way, but do not help the individual examined.

The clerk handling the performance sheet also attends to the correspondence of the assistant superintendent of locomotive fuel service, and it is his duty to furnish proper information regarding engines making poor performance.

A letter size blue-print containing concrete information is posted at each roundhouse not later than the fifteenth of each month, showing the performance on each division in each class

of service for the previous month, a red line indicating the division showing the best performance in each class of service. A bulletin is issued by the superintendent each month addressed to all employees, showing the loss or gain in dollars and cents as against the previous month, and some brief comment is made on items that require special attention in order to make further improvement.

*"Other matters that may require attention."* Good feed water is an important item. It is not always practical to obtain this. On one division we found in making tests in passenger service that as high as 20 per cent. of the fuel used was due to the excessive amount of water blown out of the boiler. By applying smaller injectors, securing more continuous boiler feed, which is particularly desirable where water is treated in engine tanks, and by careful handling of the engine, we found we could eliminate the worst tanks and almost entirely avoid the use of blow-off cocks on passenger trains.

It is an excellent plan to cultivate the acquaintance of the flue borer and the man who looks after the grates and to go into a firebox occasionally, as well as to visit the coal chute. Things that are learned in this way cannot be found out in any other way and it convinces these men that you are interested in their work and that they are an important asset in obtaining the proper use from fuel.

Sufficient draft through the ash pan is very important. It takes a great deal of air to burn coal properly. It is estimated that 20 lbs. or 260 cu. ft. of air is required for the proper combustion of one pound of coal, or 3,900 cu. ft. for each shovelful.

One thing that is frequently lost sight of is the relative cost of lubricants and fuel. I have in mind one division where the approximate cost of fuel was \$83 and the cost of lubrication 45 cents for a round trip of about 500 miles. I don't advocate wasting oil. There should be an oil schedule, but oil schedules are sometimes made similar to fuel tests; there is someone along watching it. The lubricator never runs away. The engine oiling is done just before leaving the terminal or intermediate station. In daily service, the engineer has a number of other things to look after besides the lubricator. He is not infallible and may forget to ease off the lubricator feeds or watch the guide cups at the first stop. He should, of course, watch this closely and those having supervision over the crews should keep this feature in mind. But an engine should not be run with dry valves or cylinders. The engineers should carry extra oil with them and keep the engine well lubricated at all times. If careless in the use of oil, handle that on its merits, but it is just as reasonable, in my opinion, to say we could have just so much coal to make the trip with as to start the engineers out without an emergency supply of oil, to use in case something should happen on the line. When the work was first taken up, we gave each engineer an extra one-half gallon of valve oil, keeping a record of the extra oil and a close check on the amount of oil used by each engineer for a month, to see whether it was advisable to increase the oil schedule to save fuel. At the end of thirty days, we found it was not necessary to increase the oil allowance, but it is understood that we do not want to save oil at the expense of fuel.

Attention to detail is highly essential to locomotive operation. Things that are seemingly unimportant may have a decided effect on the final results. It can be safely left to the general officers to furnish new appliances. It is for us who are held responsible for the result, to keep posted and determine the best possible methods of handling such appliances to secure the maximum efficiency.

Keeping engines of a certain class in one working district is essential to proper fuel performance. Neither enginemen nor shopmen can learn the proper care of an engine in one trip. The argument that an engine is an engine and a man that knows his business ought to do as well with one as with another, is wrong and is based on false premises. Circumstances require, sometimes, that engines be shifted around considerably, but this is invariably done at the expense of the fuel bill.

The whole problem resolves itself into a question of hearty co-



operation on the part of all concerned. Anything that will help to establish a proper fuel performance on the railroad will help every other item of train operation. The work cannot possibly be departmentized. Every department on our line tries to help out in every way it can. The shop people gladly accept suggestions that make engines more economical in fuel and as comfortable for the enginemen as possible. They are very generous in inviting criticism in this respect. The same is true of the fuel department. Any changes that can be brought about in the handling or purchase of fuel that are practical are worked out.

Securing as nearly as possible a maximum tonnage rating for each locomotive is highly important for a proper fuel performance also. Of course, for obvious reasons, all of these things cannot be done at once. All of the engines are not right all of the time, neither are they all wrong all of the time, and this is also true of the men, and statements of this character should not be taken too seriously. When things go wrong, a good getting together is the best way to remedy them. We derive a great deal of benefit from the educational meetings held at the different points, and also from the different staff meetings held by the division officials. With the best system or method that can possibly be maintained, human error will always furnish the need of a very close supervision. Any device placed on the locomotive tends to make it more complicated and requires that the men who are handling it be taught its proper use and this emphasizes the need for greater education. Great good can be done in reducing the fuel bill of railroads by exercising proper care in the selection of our firemen, who will later become engineers and who will have under their supervision in the course of their career probably 50 to 100 other firemen, all of whom will profit more or less by the engineer's training. The need for firemen should be anticipated. These men, once employed, should be properly educated to perform their duties skillfully, and if they do not show aptitude, should not be allowed to remain in a vocation that they are not adapted to. A constant effort should be made to familiarize not only the enginemen but the engine handling forces and mechanics as to the right way to handle and care for locomotives, and their work should be checked up often enough to know that it is done in the right way. It is highly essential that the work of fuel economy have the unqualified support of the general officers from the president down, and on the lines which I represent we have this support.

In conclusion, I wish to say that the one thing that has done more to reduce the fuel bill on the Frisco Lines than anything else is the interest and loyalty displayed by our engineers and firemen, and it is only to be regretted that we cannot carry out all of the suggestions made by them as rapidly as we would like to.

**BELGIUM RAILWAY DEVELOPMENTS.**—The Belgian railway administration has decided to construct a new car repair shop at Monceau near Charleroi, in the heart of the industrial district, together with maintenance and erecting shops at Meirelbeke, near Ghent, and at Kinkempois, near Liège. This step has been rendered necessary by the increase in the traffic, which is illustrated by the following figures: On January 1, 1900, the total number of freight cars amounted to 60,548. Four years later the figure was 67,859, and allowing for the rolling stock now under construction and on order, there will be a total of 94,097 freight cars in service at the beginning of 1914, or an increase of about 27,000 cars in 10 years. Preliminaries have been completed in connection with the scheme for constructing a new railway from Heppen on the line from Moll to Diest, to a point on the Meuse near the Belgian-Dutch frontier. The line will cross several coal concessions in the new mining district of Limburg, and will involve the erection of large bridges over other railways. There will be no level crossings. Negotiations are proceeding with the Dutch State Railways regarding the building of an extension of their line to Sittard across the German territory.

## General News.

A station and warehouse of the Atchison, Topeka & Santa Fe, together with several box cars, were destroyed by a fire at Center, Tex., on October 29. The loss was estimated at from \$50,000 to \$75,000.

In the competition for the Pommery cup, in France, last week, a monoplane of 160 h. p. was flown from Villacoublay to Stralsund, Pomerania, 590 miles, in 5 hours, 14 minutes, or at the rate of 112¾ miles an hour.

The Western Maryland had its first general "safety-first" meeting at Hagerstown, Md., October 30. The meeting was addressed by W. P. Borland, assistant chief inspector of safety appliances for the Interstate Commerce Commission.

Leon R. Taylor, now governor of the state of New Jersey, having succeeded to that position from that of Speaker of the House of Assembly by reason of the resignation of Governor Fielder, is only 31 years old; and ten years ago he was a brakeman on the Pennsylvania Railroad.

The office of Secretary J. W. Taylor, of the Master Mechanics' and Master Car Builders' Association and the Western Railway Club, together with the library of the Western Railway Club, has been removed from the Old Colony building to more commodious quarters at 1112 Karpen building, 900 South Michigan avenue, Chicago.

The railways entering Cincinnati have recently formed a smoke inspection bureau, and G. H. Funk, superintendent of fuel economy of the Chesapeake & Ohio, has been appointed chief smoke inspector. The city has been districted and deputies will be appointed for the purpose of making observations of locomotives smoking beyond the point of density allowed by the city ordinance. The bureau reports to the General Managers' Association of Cincinnati.

Seven young men from the ranks of employees of the Southern Pacific have recently been awarded scholarships in the school of practical railroading which that company maintains. They are A. C. Posey, a lease clerk; John A. Starbuck, a freight clerk; Warren Tucker, a station baggageman; J. J. Sullivan, assistant chief clerk on the Tucson division; P. A. Warrack, a file clerk; W. M. Whitney, a draughtsman, and F. E. Yoakum, a yard clerk. Five of the seven are college graduates.

Representatives of the engineers', firemen's, switchmen's, trainmen's and conductors' brotherhoods appeared before the Chicago city council committee on railway terminals on Monday last and presented arguments against the passage of the "anti-smoke" ordinance, which the committee has recommended, but which was referred back to it in order to give the employees opportunity to be heard. The men opposed the ordinance on the ground that while it does not mention electrification it would actually require it, as there is no other means of absolutely eliminating smoke; and they opposed electrification as dangerous. One of the speakers declared it would "make a slaughter house of the Chicago railway yards."

Arbitrators have been selected to arbitrate the wage controversy between the conductors and trainmen of the Chicago, Burlington & Quincy and the company. The differences involve 35 demands submitted by the employees regarding working conditions and wages, the principal demand being for a standardization of rates. The six arbitrators named are Henry S. Boutell, Washington, D. C., and Garrett J. Diekema, of Holland, Mich., representing the government; Fairfax Harrison, president, Chicago, Indianapolis & Louisville, and P. H. Morrissey, assistant to vice-president of the Chicago, Burlington & Quincy, representing the railway, and E. P. Curtis, vice-president of the Order of Railway Conductors, and E. L. Harrigan, general chairman of the Brotherhood of Railway Trainmen, representing the employees.

The San Pedro, Los Angeles & Salt Lake has organized a safety and efficiency committee, with H. C. Nutt, general manager, as chairman, and Howard Elliott as secretary; and division committees have been formed for the Los Angeles and Salt Lake divisions. In a statement issued announcing the new committees

a table is included showing that for the past six years the company's record for persons killed is 3 passengers (none in train accidents), 15 travelers in highway, 58 employees, and 67 trespassers, while 3,245 employees have been injured. "This safety movement is a movement for the employees, of the employees, and by the employees," says the circular. It is the men on the firing line, not the officers, who are getting hurt, and the movement should receive the active support of those whom it is intended to benefit. If, in going about your daily tasks, improper and dangerous conditions are noticed, no time should be lost in reporting it to some member of the division committee; perhaps it may be possible to eliminate entirely such conditions, or at least improve them. At any rate, the first step is to see it, the second to report it, the third to consider it by the committee, and the fourth, to dispose of it, either by recommendation to the central committee, or otherwise."

#### Disastrous Collision at Melun, France.

A press despatch of November 4, reports a collision on the evening of that day on the Paris, Lyons & Mediterranean at Melun, 27 miles south of Paris, in which 39 passengers were killed and a large number injured.

#### Valuation Committees for Missouri Pacific System.

J. R. Stephens, chief engineer of the Missouri Pacific System, has been appointed general chairman of valuation committees of the Missouri Pacific; St. Louis, Iron Mountain & Southern; Denver & Rio Grande, and Western Pacific, with headquarters at St. Louis. Mr. Stephens, as general chairman, has appointed valuation committees for the different roads as follows:

Missouri Pacific and St. Louis, Iron Mountain & Southern, C. H. Smith, engineer and chairman; T. L. Philips, attorney; F. P. Johnson, accountant, and R. J. Turnbull, motive power, machinery and rolling stock, with headquarters at St. Louis.

Denver & Rio Grande, Arthur Ridgway, engineer and chairman; J. G. McMurry, attorney; E. R. Dickenson, accountant, and J. F. Enright, motive power, machinery and rolling stock, with headquarters at Denver, Colo.

Western Pacific, T. J. Wyche, engineer and chairman; A. P. Matthews, attorney; J. F. Evans, accountant, and J. F. Enright, motive power, machinery and rolling stock, with headquarters at San Francisco, Cal.

#### "Safety First" on the Pennsylvania.

*The Dispatch*, a monthly leaflet issued by the Railroad Young Men's Christian Association at the Jersey City terminal of the Pennsylvania Railroad, announces in its current issue that during the next five months a half dozen lectures will be given at the association's rooms on safety first, and allied subjects. The first lecture will be by J. B. Fisher, superintendent of the New York division, November 28; and it is entitled "Efficiency." Other addresses are arranged for as follows: December, "Book of Rules," by J. Oscar Young, chairman Safety Committee. January, "Air Brakes and Their Relation to Successful Train Operation," by B. R. Dixon, air brake inspector. January, "Signals," by W. M. Post, supervisor signals. February, "Courtesy," by Samuel Barnard. March, "Safety First," by H. J. Fackenthal, locomotive engineer.

This issue of the *Dispatch* contains a portrait of Mr. Young, the chairman referred to above, who was for some years a telegrapher on the Pennsylvania, and for ten years prior to his appointment as chairman of the Safety Committee was locomotive engineer.

The Railroad Y. M. C. A. at Jersey City has about 1,300 members.

#### The New Haven Road in Rhode Island.

The New Haven is very much concerned in your welfare because there are 195 miles of steam railroad and 346 miles of electric road in Rhode Island owned or controlled by the New Haven. Then there are each year 2,059 steamers sailing to and from Providence and 1,760 to and from Newport belonging to lines in which the New Haven has an interest, and at Newport are the main repair shops of the steamship lines, employing from 400 to 700 men. These steam, electric and water

lines employ between 8,000 and 9,000 men, with an annual payroll of nearly \$6,500,000. Rhode Island ought to take up intensive farming, and emulate Belgium.

The railroads' cost of living has increased. In 1910 41.58 per cent. of gross earnings went to the employees. In 1912 44.17 per cent. went to the employees. In 1910 3.77 per cent. went for taxes. In 1912 4.21 per cent. went for taxes. In 1910 7.91 per cent. went for dividends and surplus. In 1912 4.84 per cent. went for dividends and surplus. . . . A new management has come on the New Haven road. You have a director of the New Haven living here, Robert W. Taft. Feeling that Rhode Island should have not only a representative in the board, but also on the executive committee, Mr. Taft was elected a member of that committee on October 22. So that committee now has two from Massachusetts, one from Rhode Island, three from Connecticut, two from New York, one from Philadelphia, and myself, who while living in Boston, will try to represent the interests of all the states. Those who have business with the railroad do not meet the higher officers of the company frequently because of the multitude of transactions. It is, however, the desire of the company to have good men on guard at every place and to encourage them to be courteous, prompt and efficient in their dealings with the public. —Chairman Howard Elliott; speech at Providence.

#### "Safety First" on the Grand Trunk.

Howard G. Kelley, vice-president in charge of the operating department of the Grand Trunk Railway of Canada, has issued a circular establishing a safety organization, to attend to matters of this nature throughout the company's lines. There will be a general safety committee, consisting of the vice-president of the operating department (chairman), the vice-president in charge of the land and claims department, the chief engineer, the engineer of maintenance of way, the superintendent of motive power, the superintendent of the car department, the general superintendents and the chief claims agent. The safety engineer (George Bradshaw) will be secretary of this committee. On each division there will be a safety committee consisting of the superintendent (chairman), the master mechanic, the trainmasters, the assistant engineer, the supervisor of bridges and buildings, and seventeen men of lower rank—all departments being thus represented. Five other officers will be ex-officio members of the division safety committees, namely, superintendents of transportation, division engineers, superintendents of track, superintendents of bridges and buildings, and supervisors of signals. At the principal terminals—Montreal, Toronto, Detroit, Port Huron and Buffalo, the safety committee will be made up somewhat differently. At five principal shop centers, there will be safety committees of the locomotive department and of the car department, each separate from the other. Following are the principal rules for the guidance of the committees:

1. The chairman of each committee may appoint such members or sub-committees, in addition to those prescribed, as, in his opinion local conditions may require.

2. Unless otherwise provided, the chairman's chief clerk will act as secretary of division, terminal and shop committees.

3. All committees will meet during convenient business hours at least once a month at the office of the chairman unless otherwise designated. Special meetings may be called by the chairman of any committee.

4. Once every six months, division committees will make safety inspection, in a body, of their territory or the main part of it.

5. Division, terminal and shop committees will report to the general committee on prescribed forms and according to rules provided for the purpose and no change is to be made in the safety organization, as herein constituted, except by permission of the general safety committee.

6. Members of committees will be allowed necessary expenses when away from their homes upon committee business, and when service on committees causes a member to lose any time from his regular duties, he will be paid for such time at regular rates.

7. In the appointment of employee members of division committees, care will be taken to secure as far as possible, complete territorial representation. For example, other things being equal, it would be advisable to appoint the road foreman of engines from territory not represented by the engineer and the section

foreman from a section not included in the territory of the supervisor of track.

8. Members of committees from the lower grades are to be appointed by the chairman, and there will be rotation by new appointments, so as to bring about a gradual, but complete change of members so appointed every six months.

The circular concludes as follows: "No one will be censured, and no one should feel aggrieved on account of any report made to the safety committee, nor by reason of any action taken by it. The one object of the safety committee is to provide the greatest degree of safety for all."

#### M. C. B. and M. M. Conventions.

At the meeting of the executive committee of the Railway Supply Manufacturers' Association, held at the Vanderbilt hotel, New York, on November 4, it was decided to hold the convention of the Master Car Builders' Association and the American Railway Master Mechanics' Association at Atlantic City, N. J., next June. The convention of the Master Car Builders' Association will be held June 10-12, and the convention of the American Railway Master Mechanics' Association will be held June 15-17. Some attempts were made to have the conventions held at Milwaukee or Buffalo, but they were not successful.

It has been decided to hold two informal dances on Young's Million Dollar Pier, one for each convention, and also two at the Marlborough-Blenheim. This is practically the same as last year's program. Saturday will be set aside for viewing the exhibits; rolling chairs will be provided under the same conditions as obtained last year.

#### Central Railway Club.

At the next meeting of the Central Railway Club to be held November 14, at the Statler hotel, Buffalo, N. Y., an address will be presented by H. B. Yergason, of Rogers, Brown & Company, Cincinnati, Ohio. This address will cover iron ore mining, handling and shipping movements, the manufacture of pig iron and some of the more interesting steel processes, and will be illustrated by a series of moving pictures, showing all the operations.

### MEETINGS AND CONVENTIONS.

*The following list gives names of secretaries, dates of next or regular meetings, and places of meeting.*

- AIR BRAKE ASSOCIATION.—F. M. Nellis, 53 State St., Boston, Mass. Next convention, May, 1914.
- AMERICAN ASSOCIATION OF DEMURRAGE OFFICERS.—A. G. Thomason, Boston, Mass. Convention, May 19, 1914, St. Louis.
- AMERICAN ASSOCIATION OF GENERAL PASSENGER AND TICKET AGENTS.—W. C. Hope, New York.
- AMERICAN ASSOCIATION OF FREIGHT AGENTS.—R. O. Wells, East St. Louis, Ill. Next convention, April 21, Houston, Tex.
- AMERICAN ASSOCIATION OF RAILROAD SUPERINTENDENTS.—E. H. Hartman, St. Louis, Mo.; 3d Thursday and Friday in May.
- AMERICAN ELECTRIC RAILWAY ASSOCIATION.—H. C. Donecker, 29 W. 39th St., New York.
- AMERICAN ELECTRIC RAILWAY MANUFACTURERS' ASSOC.—H. G. McConaughy, 165 Broadway, New York. Meetings with Am. Elec. Ry. Assoc.
- AMERICAN RAILWAY ASSOCIATION.—W. F. Allen, 75 Church St., New York. Next meeting, November 19, 1913, Chicago.
- AMERICAN RAILWAY BRIDGE AND BUILDING ASSOCIATION.—C. A. Lichty, C. & N. W., Chicago. Next convention, October 20-22, 1914, Los Angeles, Cal.
- AMERICAN RAILWAY ENGINEERING ASSOCIATION.—E. H. Fritch, 900 S. Michigan Ave., Chicago. Next convention, March 17-20, Chicago.
- AMERICAN RAILWAY MASTER MECHANICS' ASSOCIATION.—J. W. Taylor, Old Colony building, Chicago.
- AMERICAN RAILWAY TOOL FOREMEN'S ASSOCIATION.—A. R. Davis, Central of Georgia, Macon, Ga.
- AMERICAN SOCIETY FOR TESTING MATERIALS.—Prof. E. Marburg, University of Pennsylvania, Philadelphia, Pa.
- AMERICAN SOCIETY OF CIVIL ENGINEERS.—C. W. Hunt, 220 W. 57th St., New York; 1st and 3d Wed., except June and August, New York.
- AMERICAN SOCIETY OF ENGINEERING CONTRACTORS.—J. R. Wenlinger, 11 Broadway, New York; 2d Tuesday of each month, New York.
- AMERICAN SOCIETY OF MECHANICAL ENGINEERS.—Calvin W. Rice, 29 W. 39th St., New York.
- AMERICAN WOOD PRESERVERS' ASSOCIATION.—F. J. Angier, B. & O., Baltimore, Md. Next convention, January 20-22, 1914, New Orleans, La.
- ASSOCIATION OF AMERICAN RAILWAY ACCOUNTING OFFICERS.—C. G. Phillips, 143 Dearborn St., Chicago. Annual meeting, May 28, Atlantic City, N. J.
- ASSOCIATION OF RAILWAY CLAIM AGENTS.—C. W. Egan, B. & O., Baltimore, Md. Next convention, May, 1914, St. Paul, Minn.
- ASSOCIATION OF RAILWAY ELECTRICAL ENGINEERS.—Jos. A. Andreucetti, C. & N. W. Ry., Chicago.
- ASSOCIATION OF RAILWAY TELEGRAPH SUPERINTENDENTS.—P. W. Drew, 112 West Adams St., Chicago. Next convention, May 20-23, New Orleans, La.
- ASSOCIATION OF TRANSPORTATION AND CAR ACCOUNTING OFFICERS.—G. P. Conard, 75 Church St., New York. Next meeting, December 9-10, Galveston, Tex.
- ASSOCIATION OF WATER LINE ACCOUNTING OFFICERS.—W. R. Evans, Chamber of Commerce, Buffalo, N. Y.
- BRIDGE AND BUILDING SUPPLY MEN'S ASSOCIATION.—L. D. Mitchell, Detroit Graphite Co., Detroit, Mich. Meeting with American Railway Bridge and Building Association.
- CANADIAN RAILWAY CLUB.—James Powell, Grand Trunk Ry., Montreal, Que.; 2d Tuesday in month, except June, July and Aug., Montreal.
- CANADIAN SOCIETY OF CIVIL ENGINEERS.—Clement H. McLeod, 413 Dorchester St., Montreal, Que.; Thursday, Montreal.
- CAR FOREMEN'S ASSOCIATION OF CHICAGO.—Aaron Kline, 841 North 50th Court, Chicago; 2d Monday in month, Chicago.
- CENTRAL RAILWAY CLUB.—H. D. Vought, 95 Liberty St., New York; 2d Thurs. in Jan. and 2d Fri. in March, May, Sept., Nov., Buffalo, N. Y.
- CIVIL ENGINEERS' SOCIETY OF ST. PAUL.—L. S. Pomeroy, Old State Capitol building, St. Paul, Minn.; 2d Monday, except June, July, August and September, St. Paul.
- ENGINEERS' SOCIETY OF PENNSYLVANIA.—E. R. Dasher, Box 704, Harrisburg, Pa.; 1st Monday after second Saturday, Harrisburg, Pa.
- ENGINEERS' SOCIETY OF WESTERN PENNSYLVANIA.—E. K. Hiles, Oliver building, Pittsburgh; 1st and 3d Tuesday, Pittsburgh, Pa.
- FREIGHT CLAIM ASSOCIATION.—Warren P. Taylor, Richmond, Va. Next convention, May 20-22, Galveston, Tex.
- GENERAL SUPERINTENDENTS' ASSOCIATION OF CHICAGO.—E. S. Koller, 226 W. Adams St., Chicago; Wed. preceding 3d Thurs., Chicago.
- INTERNATIONAL RAILWAY CONGRESS.—Executive Committee, 11, rue de Louvain, Brussels, Belgium. Convention, 1915, Berlin.
- INTERNATIONAL RAILWAY FUEL ASSOCIATION.—C. G. Hall, 922 McCormick building, Chicago. Annual convention, May 18-22, Chicago.
- INTERNATIONAL RAILWAY GENERAL FOREMEN'S ASSOCIATION.—Wm. Hall, 829 West Broadway, Winona, Minn. Next convention, July, Chicago.
- INTERNATIONAL RAILROAD MASTER BLACKSMITHS' ASSOCIATION.—A. L. Woodworth, Lima, Ohio. Next convention, third Tuesday in August.
- MAINTENANCE OF WAY & MASTER PAINTERS' ASSOCIATION OF THE UNITED STATES AND CANADA.—W. G. Wilson, Lehigh Valley, Easton, Pa. Next convention, November 18-20, Louisville, Ky.
- MASTER BOILER MAKERS' ASSOCIATION.—Harry D. Vought, 95 Liberty St., New York.
- MASTER CAR BUILDERS' ASSOCIATION.—J. W. Taylor, Old Colony building, Chicago.
- MASTER CAR & LOCOMOTIVE PAINTERS' ASSOC. OF U. S. AND CANADA.—A. P. Dane, B. & M., Reading, Mass.
- NATIONAL RAILWAY APPLIANCE ASSOC.—Bruce V. Crandall, 537 So. Dearborn St., Chicago. Meetings with Am. Ry. Eng. Assoc.
- NEW ENGLAND RAILROAD CLUB.—W. E. Cade, Jr., 683 Atlantic Ave., Boston, Mass.; 2d Tuesday in month, except June, July, Aug. and Sept., Boston.
- NEW YORK RAILROAD CLUB.—H. D. Vought, 95 Liberty St., New York; 3rd Friday in month, except June, July and August, New York.
- NORTHERN RAILROAD CLUB.—C. L. Kennedy, C. M. & St. P., Duluth, Minn.; 4th Saturday, Duluth.
- PEORIA ASSOCIATION OF RAILROAD OFFICERS.—M. W. Rotchford, Union Station, Peoria; 2d Thursday.
- RAILROAD CLUB OF KANSAS CITY.—C. Manlove, 1008 Walnut St., Kansas City, Mo.; 3d Friday in month, Kansas City.
- RAILWAY BUSINESS ASSOCIATION.—Frank W. Noxon, 2 Rector St., New York. Annual dinner, second week in December, 1913, New York.
- RAILWAY CLUB OF PITTSBURGH.—J. B. Anderson, Penna. R. R., Pittsburgh, Pa.; 4th Friday in month, except June, July and August, Pittsburgh.
- RAILWAY ELECTRICAL SUPPLY MANUFACTURERS' ASSOC.—J. Scribner, 1021 Monadnock Block, Chicago. Meetings with Assoc. Ry. Elec. Engrs.
- RAILWAY FIRE PROTECTION ASSOCIATION.—C. B. Edwards, Mobile & Ohio, Mobile, Ala.
- RAILWAY GARDENING ASSOCIATION.—J. S. Butterfield, Lee's Summit, Mo.
- RAILWAY DEVELOPMENT ASSOCIATION.—W. Nicholson, Kansas City Southern, Kansas City, Mo. Next meeting, November 11-12, Baltimore, Md.
- RAILWAY SIGNAL ASSOCIATION.—C. C. Rosenberg, Bethlehem, Pa.
- RAILWAY STOREKEEPERS' ASSOCIATION.—J. P. Murphy, Box C, Collinwood, Ohio.
- RAILWAY SUPPLY MANUFACTURERS' ASSOC.—J. D. Conway, 2135 Oliver bldg., Pittsburgh, Pa. Meetings with M. M. and M. C. B. Assocs.
- RAILWAY TEL. & TEL. APPLIANCE ASSOC.—W. E. Harkness, 284 Pearl St., New York. Meetings with Assoc. of Ry. Teleg. Sups.
- RICHMOND RAILROAD CLUB.—F. O. Robinson, Richmond, Va.; 2d Monday except June, July and August.
- ROADMASTERS' AND MAINTENANCE OF WAY ASSOCIATION.—L. C. Ryan, C. & N. W. Sterling, Ill.
- ST. LOUIS RAILWAY CLUB.—B. W. Frauenthal, Union Station, St. Louis, Mo.; 2d Friday in month, except June, July and Aug. St. Louis.
- SIGNAL APPLIANCE ASSOCIATION.—F. W. Edmonds, 3868 Park Ave., New York. Meeting with annual convention Railway Signal Association.
- SOCIETY OF RAILWAY FINANCIAL OFFICERS.—C. Nyquist, La Salle St. Station, Chicago.
- SOUTHERN ASSOCIATION OF CAR SERVICE OFFICERS.—E. W. Sandwich, A. & W. P. Ry., Montgomery, Ala.
- SOUTHERN & SOUTHWESTERN RAILWAY CLUB.—A. J. Merrill, Grant bldg., Atlanta, Ga.; 3d Thurs., Jan., March, May, July, Sept., Nov., Atlanta.
- TOLEDO TRANSPORTATION CLUB.—J. G. Macomber, Woolson Spice Co., Toledo, Ohio; 1st Saturday, Toledo.
- TRACK SUPPLY ASSOCIATION.—W. C. Kidd, Ramapo Iron Works, Hillsburn, N. Y. Meetings with Roadmasters' and Maintenance of Way Association.
- TRAFFIC CLUB OF CHICAGO.—W. H. Wharton, La Salle Hotel, Chicago.
- TRAFFIC CLUB OF NEW YORK.—C. A. Swope, 290 Broadway, New York; last Tuesday in month, except June, July and August, New York.
- TRAFFIC CLUB OF PITTSBURGH.—D. L. Wells, Erie, Pittsburgh, Pa.; meetings monthly, Pittsburgh.
- TRAFFIC CLUB OF ST. LOUIS.—A. F. Versen, Mercantile Library building, St. Louis, Mo. Annual meeting in November. Noonday meetings October to May.
- TRAIN DESPATCHERS' ASSOCIATION OF AMERICA.—J. F. Mackie, 7122 Stewart Ave., Chicago. Next convention, June 16, Jacksonville, Fla.
- TRANSPORTATION CLUB OF BUFFALO.—J. M. Sells, Buffalo; first Saturday after first Wednesday.
- TRANSPORTATION CLUB OF DETROIT.—W. R. Hurley, L. S. & M. S., Detroit, Mich.; meetings monthly.
- TRAVELING ENGINEERS' ASSOCIATION.—W. O. Thompson, N. Y. C. & H. R., East Buffalo, N. Y. Next meeting, Chicago.
- UTAH SOCIETY OF ENGINEERS.—Fred D. Ulmer, Oregon Short Line, Salt Lake City, Utah; 3rd Friday of each month, except July and August.
- WESTERN CANADA RAILWAY CLUB.—W. H. Rosevear, P. O. Box 1707, Winnipeg, Man.; 2d Monday, except June, July and August, Winnipeg.
- WESTERN RAILWAY CLUB.—J. W. Taylor, Old Colony building, Chicago; 3d Tuesday of each month, except June, July and August.
- WESTERN SOCIETY OF ENGINEERS.—J. H. Warder, 1735 Monadnock Block, Chicago; 1st Monday in month, except July and August, Chicago.

# Traffic News.

The Illinois Central has recently discontinued the practice of employing train collectors on its southern lines, and fares are now being collected by the conductors.

The schedule of the Golden State Limited train of the Chicago, Rock Island & Pacific running between Chicago and Los Angeles, will next week be reduced from 71 to 68½ hours.

H. H. Gross, president of the National Soil Fertility League, addressed the Traffic Club of Chicago at a luncheon on October 30, on "The Decline of Our Food Supply and the Remedy."

The cotton crop of Texas is about 40 or 50 per cent. less than was estimated early in the season; and the principal railroads are taking measures to reduce expenses, in the shops and elsewhere.

Tramp steamers are now taking cotton direct from Galveston to Japan by way of Suez Canal. It is said that the most common rate is \$1.30 per 100 lbs. which is 5 cents less than the usual rate by way of San Francisco.

Indictments reported last week have been followed by a decision of the court, in New York City, fining Isador Marshutz \$250 for false classification of thermometers, which were sent to the railroad described as hardware.

The Illinois Central and Yazoo & Mississippi Valley will operate a special live stock and agricultural instruction train through the state of Mississippi from November 10 to 22, in co-operation with the Mississippi Agricultural & Mechanical College.

Harry A. Kelly, a merchant of Phoenixville, Pa., has been served with an injunction by the Court of Common Pleas of Chester county, enjoining him from selling packages, or "strip" tickets over the Pennsylvania Railroad. For some time past Kelly has been purchasing package tickets from the railroad, and retailing them at prices lower than the regular one-way or round-trip rates. The laws of the state make it a misdemeanor for anyone to sell railroad tickets except duly authorized agents of the carrier.

At Pittsburgh and East Liberty, on the Pennsylvania Railroad, passengers need not surrender their mileage books to the Pullman conductors when beginning a night trip. One intending to ride overnight and who owns a book of mileage coupons can take the book to the ticket office and exchange the required number of miles for a regular ticket. In this way he will get the benefit of the low mileage rate and will have his mileage coupons cancelled in his presence. If this new rule is found to be satisfactory to patrons it may be extended to other stations out of which there is heavy night travel.

### Car Location.

The accompanying table, which was taken from bulletin No. 11 of the American Railway Association, gives a summary of freight car location by groups on October 1, 1913.

### Summary of Revenues and Expenses of Steam Roads in July and August.

The Bureau of Railway Economics' summary of revenues and expenses and comments thereon for the months of July and August are as follows:

#### SUMMARY FOR THE MONTH OF JULY.

The railways whose returns are included in the summary for July operate 224,451 miles of line, or about 90 per cent. of the steam railway mileage in the United States. Total operating revenues for the month of July, 1913, amounted to \$260,724,533. Compared with July, 1912, the total operating revenues show an increase of \$13,413,516. These total operating revenues per mile of line averaged \$1,162 in July, 1913, and \$1,113 in July, 1912, an increase of \$49 or 4.4 per cent. Freight revenue per mile increased 3.9 per cent. and passenger revenue per mile 5.9 per cent.

Operating expenses amounted to \$182,677,490. This was \$15,957,292 more than for July, 1912. These operating expenses per mile of line averaged \$814 in July, 1913, and \$750 in July, 1912, an increase of \$64 per mile, or 8.5 per cent.

Net operating revenue amounted to \$78,047,043. This was \$2,543,776 less than for July, 1912. Net operating revenue per mile of line averaged \$348 in July, 1913, and \$363 in July, 1912, a decrease of \$15 per mile, or 4.1 per cent.

Taxes for the month of July amounted to \$10,753,106, or \$47.91 per mile, an increase of 7.3 per cent. over July, 1912.

Operating income averaged \$300 per mile of line, and in July, 1912, \$319, thus decreasing \$19, or 5.9 per cent. Operating income for each mile of line for each day in July averaged \$9.68 and for July, 1912, \$10.28.

The operating ratio for July was 70.1 per cent., which is comparable with 70.4 per cent. in June, 1913, and 67.4 per cent. in July, 1912.

The railways of the eastern district show an increase in total operating revenues per mile of line as compared with July, 1912, of 5.5 per cent., the railways of the southern district an increase of 4.2 per cent., and the railways of the western district an increase of 3.7 per cent. Operating expenses per mile increased 12.0 per cent. on the eastern railways, 5.1 per cent. on the southern railways, and 6.4 per cent. on the western railways. For the eastern railways net operating revenue per mile decreased 7.8 per cent., for the southern railways it increased 1.6 per cent., while for the western railways it decreased 1.3 per cent. The increase in taxes per mile was 4.2 per cent. in the eastern district, 6.9 per cent. in the southern district, and 10.7 per cent. in the western district. Operating income per mile decreased 10.0 per cent. in the East, increased 0.8 per cent. in the South, and decreased 2.8 per cent. in the West.

When the returns for the seven months of the calendar year 1913 are compared with those of the corresponding months of 1912, they show an increase in total operating revenues per mile of 8.1 per cent., an increase in operating expenses per mile of 9.7 per cent., and an increase in net operating revenue per mile of 4.0 per cent. This net operating revenue per mile increased 0.5 per cent. in the eastern

CAR LOCATION ON OCTOBER 1, 1913.

	New England.	N.Y., N.J., Del., Md., Eastern Pa.	Ohio, Ind., Mich., Western Pa.	Va., W. Va., No. & So. Carolina.	Ky., Tenn., Miss., Ala., Ga., Fla.	Iowa, Ill., Wis., Minn.	Mont., Wyo., Neb., Dakotas.	Kans., Colo., Okla., Mo., Ark.	Texas, La., New Mexico.	Oregon, Idaho, Nev., Ariz., Cal.	Canadian Lines.	Grand Total.
Total Cars Owned .....	88,207	684,512	280,156	204,173	172,254	492,886	18,925	114,969	29,138	134,091	141,443	2,360,754
Home Cars on Home Roads .....	42,180	375,917	101,889	106,132	83,448	333,350	7,018	59,982	12,924	74,260	95,058	1,292,158
Home Cars on Foreign Roads .....	46,027	308,595	178,267	98,041	88,806	159,536	11,907	54,987	16,214	59,831	46,385	1,068,596
Foreign Cars on Home Roads .....	54,256	311,026	222,082	80,054	75,452	203,052	9,883	54,805	28,845	57,614	40,131	1,137,200
Total Cars on Line .....	96,436	686,943	323,971	186,186	158,900	536,402	16,901	114,787	41,769	131,874	135,189	2,429,358
Excess or Deficiency .....	8,229	2,431	43,815	*17,987	*13,354	43,516	*2,024	*182	12,631	*2,217	*6,254	68,604
Surplus .....	127	1,892	946	5,273	466	6,078	1,053	7,217	5,182	12,185	1,575	41,994
Shortage .....	1,531	3,349	3,784	9,354	2,121	3,619	195	622	136	1,666	5,243	31,620
Shop Cars—												
Home Cars in Home Shops .....	6,272	37,555	22,447	13,287	12,970	29,119	509	8,675	2,320	4,494	6,920	144,568
Foreign Cars in Home Shops .....	1,160	7,643	8,447	1,854	2,270	5,569	412	1,907	790	2,033	461	32,546
Total Cars in Shops .....	7,432	45,198	30,894	15,141	15,240	34,688	921	10,582	3,110	6,527	7,381	177,114
Per Cent. to Total Cars Owned—												
Home Cars on Home Roads .....	47.82	54.92	36.37	51.98	48.44	67.63	37.08	52.17	44.35	55.38	67.21	54.73
Total Cars on Line .....	106.71	100.36	115.35	91.19	92.25	108.83	89.31	97.61	143.35	98.35	95.58	102.91
Home Cars in Home Shops .....	7.11	5.49	8.01	6.51	7.53	5.94	2.69	7.54	7.96	3.35	4.89	6.12
Foreign Cars in Home Shops .....	.95	1.11	3.02	.91	1.32	1.14	2.18	1.50	2.71	1.52	.33	1.38
Total Cars in Shops .....	8.06	6.60	11.03	7.42	8.85	7.08	4.87	9.04	10.67	4.87	5.22	7.50

\*Denotes deficiency.

district as compared with the corresponding period of the previous year, increased 5.6 per cent. in the southern district, and increased 7.4 per cent. in the western district.

The following table shows the per cent. of operating revenues consumed by each class of expenses:

	PER CENT. OF TOTAL OPERATING EXPENSES.					
	1913.		1912.		1911.	
	July.	Calendar year ending December 31.	July.	Calendar year ending December 31.	July.	Calendar year ending December 31.
Maintenance of way and structures	15.0	13.9	12.8	12.7	14.0	12.9
Maintenance of equipment	16.6	15.9	16.0	15.7	17.3	16.6
Traffic expenses	2.1	2.1	2.0	2.1	2.1	2.2
Transportation expenses	34.0	33.1	35.5	35.4	36.8	37.5
General expenses	2.4	2.4	2.4	2.5	2.6	2.6
<b>Total operating expenses</b>	<b>70.1</b>	<b>67.4</b>	<b>68.7</b>	<b>68.4</b>	<b>72.8</b>	<b>71.8</b>

SUMMARY FOR THE MONTH OF AUGUST.

The railways whose returns are included in the summary of revenue and expenses for August operate 224,491 miles of line, or about 90 per cent. of the steam railway mileage in the United States. The operating revenues for the month of August, 1913, amounted to \$273,602,765. Compared with August, 1912, the total operating revenues show an increase of \$3,965,777. These total operating revenues per mile of line

August averaged \$10.97 and for August, 1912, \$12.70. The operating ratio for August was 68.2 per cent., which is comparable with 70.1 per cent. in July, 1913, and 64.0 per cent. in August, 1912.

The railways of the eastern district show an increase in total operating revenues per mile of line as compared with August, 1912, of 0.8 per cent., the railways of the southern district an increase of 1.4 per cent., and the railways of the western district an increase of 0.4 per cent. Operating expenses per mile increased 9.4 per cent. on the eastern railways, 6.1 per cent. on the southern railways, and 5.2 per cent. on the western railways. For the eastern railways net operating revenue per mile decreased 14.3 per cent., for the southern railways it decreased 9.9 per cent., and for the western railways it decreased 7.4 per cent. The increase in taxes per mile was 5.6 per cent. in the eastern district, 7.2 per cent. in the southern district, and 15.1 per cent. in the western district. Operating income per mile decreased 17.3 per cent. in the East, decreased 12.2 per cent. in the South, and decreased 9.8 per cent. in the West.

Comparison of the returns for the two months of the current fiscal year with those of the corresponding months of the previous fiscal year reveals an increase in total operating

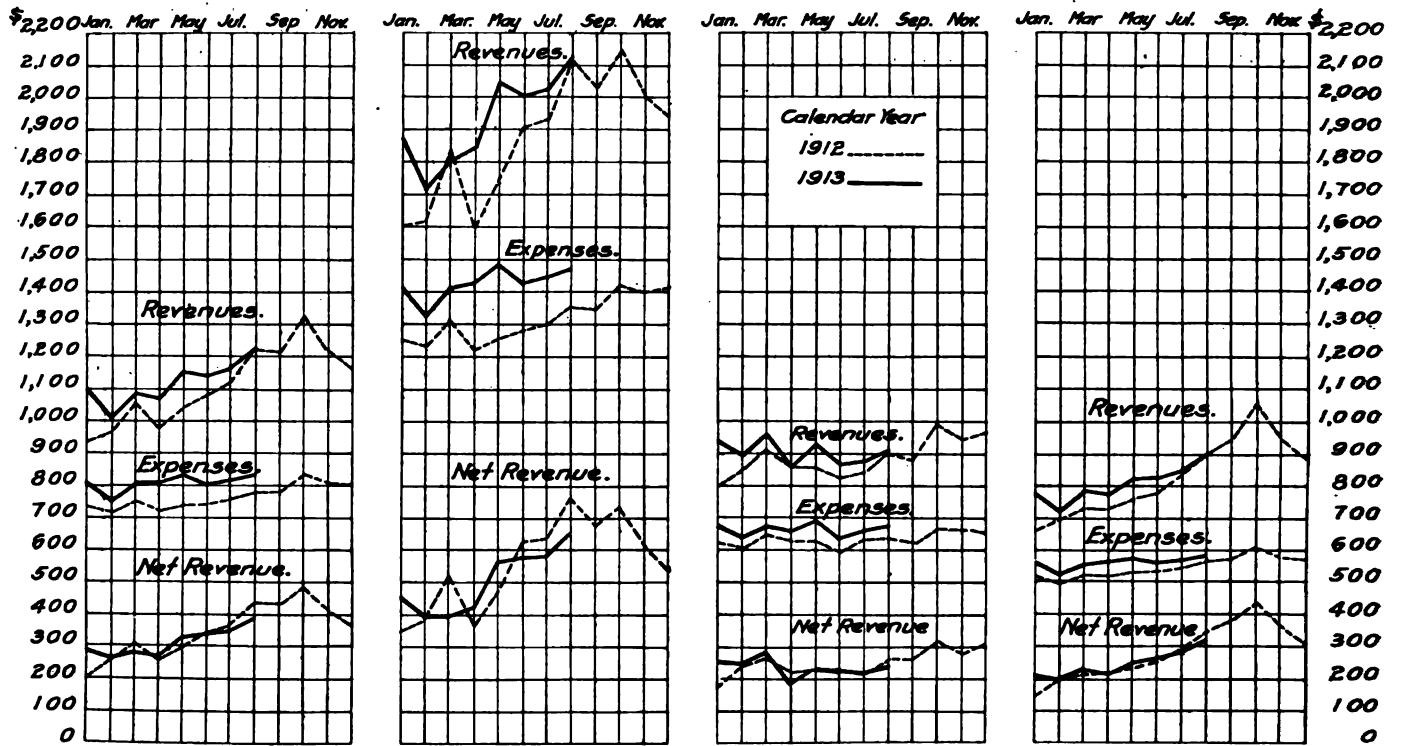

Monthly Revenues and Expenses Per Mile of Line in 1912 and 1913.

averaged \$1,219 in August, 1913, and \$1,212 in August, 1912, an increase of \$7 or 0.6 per cent. Freight revenue decreased \$59,372, which is equivalent to a decrease of 0.9 per cent. on a per-mile basis. Passenger revenue per mile increased 4.3 per cent.

Operating expenses amounted to \$186,533,549. This was \$13,798,063 more than for August, 1912. These operating expenses per mile of line averaged \$831 in August, 1913, and \$776 in August, 1912, an increase of \$55 per mile, or 7.1 per cent.

Net operating revenue amounted to \$87,069,216. This was \$9,832,286 less than for August, 1912. Net operating revenue per mile of line averaged \$388 in August, 1913, and \$435 in August, 1912, a decrease of \$47.52 per mile, or 10.9 per cent.

Taxes for the month of August amounted to \$11,002,857, or \$49.01 per mile, an increase of 9.8 per cent. over August, 1912.

Operating income averaged \$340 per mile of line, and in August, 1912, \$394, thus decreasing \$54, or 13.6 per cent. Operating income for each mile of line for each day in

revenues per mile of 2.4 per cent., an increase in operating expenses per mile of 7.8 per cent., and a decrease in net operating revenue per mile of 7.8 per cent. This net operating revenue per mile of the eastern railways decreased 11.3 per cent. as compared with the corresponding period of the previous year, that of the southern railways decreased 4.7 per cent., and that of the western railways decreased 4.6 per cent.

When the returns for the eight months of the calendar year 1913 are compared with those of the corresponding months of 1912, they show an increase in total operating revenues per mile of 7.0 per cent., an increase in operating expenses per mile of 9.3 per cent., and an increase in net operating revenue per mile of 1.3 per cent. This net operating revenue per mile decreased 2.3 per cent. in the eastern district as compared with the corresponding period of the previous year, increased 3.4 per cent. in the southern district, and increased 4.7 per cent. in the western district.

The diagrams show the variations in operating revenues, operating expenses, and net operating revenue per mile for the separate months of the calendar year 1912 and of the

calendar year 1913 to date. The following table shows the per cent. of operating revenue consumed by each class of expenses:

PER CENT. OF TOTAL OPERATING EXPENSES.

	Calendar year ending December 31.				Eight months ending August 31.	
	August.				1913.	1912.
	1913.	1912.	1912.	1911.	1913.	1912.
Maintenance of way and structures	14.4	13.4	12.8	12.7	14.0	12.9
Maintenance of equipment.....	16.5	15.3	16.0	15.7	17.2	16.4
Traffic expenses .....	2.0	1.8	2.0	2.1	2.1	2.2
Transportation expenses .....	33.0	31.4	35.5	35.4	36.3	36.6
General expenses .....	2.3	2.1	2.4	2.5	2.6	2.5
Total operating expenses.....	68.2	64.0	68.7	68.4	72.2	70.6

Revenues and Expenses of Large Steam Roads for September.

The following figures were compiled by the Interstate Commerce Commission from monthly reports of operating revenues and expenses of large steam roads for the month of September, on hand November 3, 1913. No reports are included for roads whose operating revenues for the year ended June 30, 1913, did not reach \$1,000,000. The figures are compiled as rendered and

The relation between this increased production and railway facilities is graphically shown by statistics of the Interstate Commerce Commission, which show that the freight traffic of the railways in the territory south of the Ohio and Potomac rivers and east of the Mississippi increased from 17,096,672,680 ton miles in 1900 to 33,840,444,295 ton miles in 1910, or 97.9 per cent., while in the same period passenger traffic increased from 1,501,533,479 passenger miles to 3,223,945,565 passenger miles, or 114.7 per cent. In this period the facilities of the railways of the Southeast were not increased in proportion to the increase in traffic. The ability of the railways to carry the constantly increasing products of the section to market has been in great measure due to a larger and more efficient use of their facilities. The most urgent need will be in the enlargement of the facilities of existing railway lines by the provision of additional trackage and equipment. In 1900 the railway system of the Southeast, considered as a whole, was substantially a single track system. The point has already been reached where the commerce of the section can no longer be handled on single-track railways. In the ten years from 1900 to 1910 the length of second track on the railways of the Southeast increased from 264 miles to 1,740

REVENUES AND EXPENSES OF LARGE STEAM ROADS FOR SEPTEMBER.

Item.	United States.		Eastern District.		Southern District.		Western District.	
	1913.	1912.	1913.	1912.	1913.	1912.	1913.	1912.
Number of reports included...	125		54		29		42	
FOR THE MONTH OF SEPTEMBER.								
Average number of miles operated .....	155,411.63	154,303.27	39,214.63	39,087.86	32,228.09	32,079.52	83,968.91	83,135.89
Total operating revenues.....	\$192,044,352	\$185,250,846	\$82,885,906	\$79,466,869	\$30,978,992	\$28,667,505	\$78,179,454	\$77,116,472
Total operating expenses.....	130,241,250	119,854,156	58,768,977	52,064,006	22,059,655	20,494,628	49,412,617	47,295,522
Net operating revenue.....	61,803,102	65,396,690	24,116,929	27,402,863	8,919,336	8,172,877	28,766,837	29,820,950
Revenues per mile.....	1,235	1,200	2,113	2,033	961	893	931	927
Expenses per mile.....	838	776	1,498	1,332	684	639	588	568
Net revenue per mile.....	397	424	615	701	277	254	343	309
FOR THE THREE MONTHS ENDING WITH SEPTEMBER.								
Average number of miles operated .....	155,363.93	154,212.10	39,194.29	39,085.60	32,228.23	32,065.17	83,941.41	83,061.33
Total operating revenues.....	\$563,133,167	\$544,693,689	\$248,288,260	\$239,817,358	\$89,493,059	\$85,180,886	\$225,351,848	\$219,695,445
Total operating expenses.....	387,903,357	355,915,713	175,159,432	155,395,656	65,768,588	61,825,746	146,975,337	138,694,311
Net operating revenue.....	175,229,810	188,777,976	73,128,828	84,421,702	23,724,471	23,354,140	78,376,511	81,001,134
Revenues per mile.....	3,624	3,532	6,334	6,135	2,777	2,656	2,684	2,644
Expenses per mile.....	2,496	2,308	4,459	3,975	2,041	1,928	1,751	1,669
Net revenue per mile.....	1,128	1,224	1,865	2,160	736	728	933	975

COMPARATIVE FIGURES BASED ON ALL ROADS HAVING REVENUES ABOVE \$1,000,000 PER ANNUM REPORTING FOR SEPTEMBER, 1912.

	1912.	1911.	1912.	1911.	1912.	1911.	1912.	1911.
For the month:								
Average number of miles operated .....	220,452.81	218,288.11	57,932.85	57,484.07	41,438.64	41,120.17	121,081.32	119,683.87
Revenues per mile.....	\$1,212	\$1,136	\$2,025	\$1,903	\$875	\$866	\$938	\$861
Expenses per mile.....	779	725	1,343	1,244	620	582	564	525
Net revenue per mile.....	433	411	682	659	255	284	374	336
For three months:								
Average number of miles operated .....	220,311.72	218,202.20	57,930.39	57,477.78	41,424.91	41,078.85	120,956.42	119,645.57
Revenues per mile.....	\$3,549	\$3,281	\$6,074	\$5,584	\$2,607	\$2,499	\$2,662	\$2,443
Expenses per mile.....	2,314	2,150	3,991	3,661	1,877	1,727	1,660	1,569
Net revenue per mile.....	1,235	1,131	2,083	1,923	730	772	1,002	674

should not be considered final, inasmuch as scrutiny of the reports may lead to their modification before acceptance.

Development of the Southern States.\*

Great as has been the progress of the Southeastern States in the past, I believe that it is but the promise of what their enterprising and progressive people shall accomplish. In the nine States of Virginia, the Carolinas, Georgia, Florida, Alabama, Mississippi, Kentucky and Tennessee, the Census Bureau reports that the value of farm property increased from \$2,189,114,320 in 1900, to \$4,461,411,250 in 1910, an increase of 103.8 per cent., as compared with 35.6 per cent. for New England, 28.1 per cent. for the Middle Atlantic States, and 78 per cent. for the Middle Western States of Ohio, Indiana, Illinois, Michigan and Wisconsin. The value of all farm crops increased 102 per cent., the value of manufactures from \$701,560,000 in 1899, to \$1,455,927,000 in 1909, an increase of \$754,871,000, or 107.7 per cent.

Since these census figures were compiled the growth of this section, so greatly favored by nature, has continued. Southeastern farmers are essentially progressive. They are adopting the most improved methods, and the figures of the United States Agricultural Department show that, making allowance for seasonal variations, the average yield per acre of each crop reported on by the department is increasing in every Southeastern State.

\*From an address by W. W. Finley, President of the Southern Railway, at the National Conservation Exposition, Knoxville, Tenn., October 21.

miles, or 558.58 per cent. Great as this percentage of increase is, it represents the double-tracking of relatively a small proportion of the railway mileage of the Southeast.

INTERSTATE COMMERCE COMMISSION.

The New Orleans Board of Trade has filed a complaint with the Interstate Commerce Commission asking a readjustment of the rates on grain and grain products, hay and feed from New Orleans to Mississippi points.

The commission has suspended from November 28 until May 28 certain tariffs presented by the Chicago, Rock Island & Pacific and the St. Louis & San Francisco advancing rates on wheat and other grains from Oklahoma to Memphis.

The commission has suspended from November 29 until May 29 the operation of certain tariffs of the Northern Pacific, by which it was proposed to advance rates on cement from Trident and Gardiner, Mont., to Spokane, Seattle and other points.

The commission has further suspended from November 18 until May 18 the operation of a Baltimore & Ohio Chicago terminal tariff advancing rates on crushed stone from McCook and Thornton, Ill., to various points in Indiana and Michigan.

The commission has suspended from November 27 until May 27 certain tariffs presented by the Chicago, Burlington &

Quincy and the Grand Trunk increasing switching charges on coal and coke over the Chicago & North Western to Ravenswood.

The commission has suspended from November 5 until May 5 the operation of certain items in Chicago & North Western tariff No. 7,423, increasing rates on grain from points in Central Freight Association Territory to Eastern and Seaboard points.

The commission has further suspended from November 17 until May 17 the operation of certain tariffs by which it was proposed to increase rates on lumber from stations on the St. Louis, Iron Mountain & Southern to stations on the Atchison, Topeka & Santa Fe.

The Topeka Traffic Association has filed with the Interstate Commerce Commission a complaint against class and commodity rates from New Orleans and Memphis to Topeka, which are declared high as compared with the rates from those points to other points in Kansas, Missouri and Nebraska.

The commission has further suspended from November 29 until May 29 the item in a supplement to Agent W. H. Hosmer's tariff, which contains advanced rates on packing house products, C. L., from Marshalltown, Cedar Rapids and Des Moines, Ia., to Chippewa Falls, Wis., Eau Claire, Wis., St. Paul, Minn., and other points.

Representatives of 34 coal companies operating in the Springfield district of Illinois appeared at a hearing before Interstate Commerce Commissioner Harlan at Chicago, on October 27, on their complaint against the adjustment of rates from the Springfield group as compared with the rates of other groups from Illinois to Indiana.

The commission has further suspended from November 12 until May 12 the operation of certain schedules in tariffs of the Illinois Central, Louisiana Railway & Navigation Company, Louisville & Nashville, Sunset Lines, the Queen & Crescent, New Orleans Great Northern, New Orleans, Texas & Mexico, Louisiana Southern and the Texas & Pacific.

The commission has ordered suspended until February 21 the operation of an item in Illinois Central tariff No. 4,285. It was proposed by the suspended item to increase the rates on cotton seed to Memphis, from points in Mississippi. The present rate from these points to Memphis is 12 cents per 100 lbs.; the proposed rate is 15 cents per 100 lbs.

The commission has suspended from November 1 until May 1 the operation of certain items in a supplement to Chicago, Rock Island & Pacific tariff C-6,948, which provide for the cancellation of through rates now in effect on grain in carloads, from points in Chicago, St. Louis and Mississippi River rate territory to stations in Oklahoma on the Fort Smith & Western.

The commission has further suspended from November 29 until May 29 certain schedules in the tariff of the Chicago, St. Paul, Minneapolis & Omaha, by which it was proposed to cancel commodity rates on emigrant movables between Chicago, St. Paul, St. Louis, Kansas City and other points and stations on the South Dakota Central, leaving in effect class rates, which would have resulted in material advances.

The commission has further suspended from November 14 until May 14 the operation of certain tariffs of the Chicago & Eastern Illinois, the Rock Island and the Sunset Central lines, the Missouri Pacific and the St. Louis & San Francisco. The tariff contains advances in rates on lumber of all kinds from points in Arkansas, Louisiana, Missouri, Oklahoma and Texas to points in Iowa, Wisconsin and other states.

The commission has suspended from November 1 until March 1 certain schedules in a supplement to the tariff of the Southern Railway. The present switching charge assessed by the Southern Railway on carload shipments of coal and coke moved from point of interchange with the Washington Southern at Potomac Yards, Va., to industries located on the Southern Railway within the switching limits of Alexandria, Va., is 11 cents per ton. It was proposed by the suspended schedules to increase this charge to 35 cents per ton.

Examiner Flynn, of the Interstate Commerce Commission, on October 21, held a hearing at Denver, Colo., on complaint of

Summit county citizens against the Colorado & Southern, attacking an advance in rates on zinc ore between Breckenridge and Denver. This rate is over a line which the railway recently sought to abandon because of the great expense of operation during the winter over Boreas Pass, and which the state railroad commission ordered re-opened in a decision which was sustained by the Supreme Court of the state.

The commission has suspended until February 28 the schedules in certain tariffs proposed to cancel through rates on lumber and articles taking lumber rates from points on the Oregon-Washington Railway & Navigation Company via Plummer, Idaho, and the Chicago, Milwaukee & St. Paul, destined to points located on or reached via the latter road. This would result in material increases on such traffic when routed via Plummer, Idaho, on and after October 31, 1913. The commission now has under investigation the proposed cancellation of rates on lumber and other commodities from North Pacific Coast points via various other western gateways.

The commission has suspended from November 8 until March 7 the item in Agent M. P. Washburn's tariff, which proposed to establish a carload rate of 15 cents per 100 lbs. for the transportation in tank cars of low grade blackstrap molasses from Mobile, Ala., to St. Louis, Mo., and East St. Louis, Ill., when imported from Cuba, unloaded into storage tanks at Mobile and reshipped from storage tanks via the Mobile & Ohio. The present rate on this commodity from Mobile to the same points of destination is 21 cents per 100 lbs. It is alleged in complaints filed with the commission that the proposed rate is discriminatory, in that it would favor a particular shipper.

The commission has suspended from November 1 until March 1 certain schedules in a supplement to Agent F. A. Leland's tariff, which proposed to cancel present through commodity rates on inedible tallow, C. L., from Muskogee, Oklahoma City and other points in the state of Oklahoma to Cincinnati, Ohio, and Hammond, Ind., and certain other interstate points, provision being made for the application of class rates on and after November 1, 1913. The present commodity rate on this traffic from Muskogee, Okla., to Hammond, Ind., for example, is 30 cents per 100 lbs.; the class rate applicable as a result of the proposed cancellation would have been 53 cents per 100 lbs.

The commission has suspended from November 1 until January 28, supplements to the tariffs of the Minneapolis, St. Paul & Sault Ste. Marie, the Northern Pacific and the Great Northern. Under present tariff provisions, shipments of butter, eggs, cheese and dressed poultry may be forwarded from local stations on the lines of the above named carriers to St. Paul, Minn., and certain other points for concentration and storage at the local rates into the concentration point. The local rates up to 40 cents per 100 lbs. are refunded to shippers on such traffic when reshipped from concentration points to final destinations in Oregon, Washington and other western states. It is proposed by the suspended schedules to cancel such privileges.

#### Kansas-Iowa Brick Rates.

##### *Opinion by Chairman Clark:*

Proposed increased rate on brick from points in the Kansas gas belt to Chicago, Rock Island & Pacific Railway stations in Iowa found not to have been justified. (28 I. C. C., 285.)

#### Brick Rates from Ohio Points to Huntington, W. Va.

##### *Opinion by Chairman Clark:*

Increased rates on brick in carload lots from the Hocking, Shawnee and Zanesville groups in southern Ohio to Huntington, W. Va., held not justified. (28 I. C. C., 292.)

#### Complaint Dismissed.

##### *Lebanon Commercial Club v. Louisville & Nashville et al.* *Opinion by Commissioner Marble:*

Local rates for the transportation of bituminous coal in carloads from mines located on the Louisville & Nashville in Virginia and Tennessee to Louisville, Ky., are less than to Lebanon, Ky., an intermediate local point 67 miles nearer to the mines than is Louisville, and vary according to the grade of the coal, while the rates to Lebanon are not so varied. The commission

decided that as the rates to Louisville are influenced largely by the movement of bituminous coal by the Ohio river and by competing rail carriers, the lower and varied rates to that point have not been shown to be unjustly discriminatory as against Lebanon. (28 I. C. C., 301.)

#### Brick Rates to Huntington.

##### *Opinion by Chairman Clark:*

Increased rates on brick in carload lots from the Hocking, Shawnee and Zanesville groups in southern Ohio to Huntington, W. Va., not justified. New tariff ordered withdrawn. (28 I. C. C., 292.)

#### Paper Rates from Manitowoc and Milwaukee to Kaukauna, Wis.

##### *Opinion by Commissioner Meyer:*

The propriety of an increase of a rate of 5½ cents on one kind of paper to 7½ cents, coincident with a reduction of a rate of 10 cents to 7½ cents on all other kinds of paper, from Milwaukee and Manitowoc, Wis., to Kaukauna, Wis., was found to have been established. (28 I. C. C., 305.)

#### Vegetable Rates Reduced.

##### *Crutchfield, Woolfolk & Clore et al v. Florida East Coast Ry. et al. Opinion by Commissioner McChord:*

Rates charged by defendants for transportation of vegetables in mixed carloads and potatoes in hampers from points on the line of the Florida East Coast Railway, in Florida, to Chicago, Ill., found unreasonable. Reparation ordered. (28 I. C. C., 274.)

#### Commodity Rates Between Missouri River Points; Increases Approved.

##### *Opinion by Commissioner McChord:*

Proposed increased rates on commodities between Missouri river points not found to result in excessive revenue to respondents. . . . Order of suspension vacated.—*Reported last week.* (28 I. C. C., 265.)

#### Broom Rate Increased.

##### *Opinion by Commissioner Marble:*

By an order dated February 6, 1913, the commission suspended tariffs, which increased certain carload rates on brooms to Colorado common points ten cents per 100 lbs. The commission decided that the carriers had justified the increased rates and vacated the order of suspension. (28 I. C. C., 310.)

#### Oklahoma-Colorado Potato Rates.

##### *Opinion by Commissioner McChord:*

Proposed increased rates on potatoes from points in Oklahoma to points in Colorado held to have been justified. Order of suspension vacated.

If, when viewed in the light of those considerations which enter into proper rate making, a particular rate is fair and just for the service performed, the price at which the shipper markets his product cannot be accepted as the controlling factor in fixing the rate. (28 I. C. C., 298.)

#### Refrigerating Charges Not Increased.

*In re investigation and suspension of advances in charges by carriers for the refrigeration of carload shipments of fruit, vegetables, etc., between points in Colorado and Utah. Opinion by Commissioner Marble:*

The proposed increase to \$40 per car for icing deciduous fruits and vegetables was withdrawn and the previous rate of \$35 per car was restored. The commission decided that the rate of \$35 per car was reasonable and dismissed the proceedings. (28 I. C. C., 326.)

#### New Mexico Coal Rates.

##### *Opinion by Commissioner Marble:*

The commission found that the proposed increases in the New Mexico coal rates were unreasonable and that the present

rates were reasonable. The only reason for the proposed increases was that the carriers could not agree on the division of the present joint rates. If the carriers interested at the end of 60 days, are still unable to agree upon division, the commission will, upon petition, prescribe the proper division. (28 I. C. C., 328.)

#### Reparation Awarded.

##### *Acme Portland Cement Company v. American Express Company. Opinion by Commissioner Marble:*

The complainant shipped a large number of securities from New York to Spokane, Wash., to be canceled. No valuation was put upon the shipment by the shipper. The complainant appraised the shipment at its par value and collected charges accordingly. The commission found that this was unreasonable and that the value of the property represented by the securities should be taken as the value of the securities. (28 I. C. C., 316.)

#### Butter and Cheese Rates Not Increased.

##### *Opinion by Commissioner Marble:*

By the tariff under suspension, the Delaware, Lackawanna & Western proposed to increase the rate on butter and cheese to New York from points on its Cincinnatus branch from 28 cents and 30 cents per 100 lbs. to 29 cents and 35 cents per 100 lbs. respectively. The line of the Lackawanna from its Cincinnatus branch to New York passes through Pennsylvania and New Jersey. The reason for the proposed increases was that the earnings of the Cincinnatus branch were not adequate and large sums had been expended on additions and betterments. The commission found that the Lackawanna had paid substantial dividends on its stock and decided that the proposed increased rates were unjust and unreasonable and ordered the present rates to be continued for the next two years. (28 I. C. C., 330.)

#### Lumber Rates Not Increased.

##### *Opinion by Commissioner Marble:*

By the tariff under suspension it was proposed to increase the rates on lumber from New Castle, New England Mills, Colfax and Gold Run, Cal., to points intermediate between the California-Nevada state line and Reno, Nev., over the Southern Pacific. By this tariff it was proposed that the commodity rate of \$2 per ton to Verdi, and \$2.25 per ton to Reno, should be canceled, leaving class rates only in effect. These rates amount to \$5.40 per ton and are so high that no contention is made that they should be regarded as reasonable. The commission found that the proposed cancellation of rates was made only for the purpose of removing a factor which might indicate a violation of the fourth section of the act to regulate commerce. No attempt was made to justify the rates which would result, beyond the statement that nothing will be offered for transportation thereunder. The commission decided that the proposed increases were unreasonable and ordered that the present rates should be continued for the next two years. (28 I. C. C., 313.)

#### Mileage Books.

*In re practices and regulations governing the issuance, sale and exchange of mileage books. Opinion by Commissioner Marble:*

The railroad commission of South Carolina complains that the requirements applying to the interchangeable mileage books used in interstate travel, to the effect that the coupons must be exchanged at ticket windows, is unreasonable in itself and results in discrimination against interstate travelers in South Carolina as compared with intrastate travelers therein whose mileage is good upon trains without such exchange. The Interstate Commerce Commission is asked to condemn the practice of carriers east of the Mississippi and south of the Ohio and Potomac rivers by which mileage is good only for exchange at ticket offices and to require that such mileage shall be receivable upon trains for transportation. The commission found that the acceptance of state mileage upon trains and the contemporaneous requirement that interstate mileage must be exchanged for tickets did not constitute a discrimination against interstate travelers. No interstate traveler is injured or hindered in any way by the fact that state travelers in South



Carolina may use the state mileage upon trains. No interstate traveler would be saved from any burden or inconvenience by the withdrawal from travelers in South Carolina of the privilege of presenting mileage books on trains. And therefore, no discrimination results from these practices. Neither is the practice unreasonable. Ordinary passengers must now pay a higher rate than the mileage rate and must exchange their cash for tickets at the station before checking baggage and before boarding trains. If they tender cash upon trains they are charged a penalty in addition to the single ticket rate. Holders of mileage tickets have experienced some inconveniences, but these can be removed by increased efficiency in station operation which will benefit all travelers alike. The complaint was dismissed. (28 I. C. C., 318.)

#### STATE COMMISSIONS.

The Oklahoma Corporation Commission has denied a petition of the railways of the state for a rehearing on its recent order requiring trains to stop at stations nearest the state line in order to allow interstate passengers to purchase tickets at the state rates.

The Missouri Public Service Commission has directed the Mississippi River & Bonne Terre, Missouri & North Arkansas, and the Missouri Southern to file with the commission, by December 31, statements showing their physical valuation in support of their application for permission to charge three-cents-a-mile passenger fares. The companies will also be required to open their books to accountants in the employ of the commission.

The Minnesota Railroad and Warehouse Commission has announced its new tariffs of freight rates prepared to conform to the Cashman distance tariff law enacted by the last legislature and effective next January. The new rates differ little from the rates adopted in 1907, and sustained by the Supreme Court in the Minnesota rate case, except that they are both maximum and minimum rates, while the existing rates are only maximum rates.

#### COURT NEWS.

The Supreme Court of the United States on Monday of this week sustained the order of the Interstate Commerce Commission reducing freight rates on lemons from California to Atlantic seaboard points from \$1.15 per 100 lbs. to \$1.

Willard P. Brown, of the firm of W. P. Brown & Co., has pleaded guilty in the Criminal Branch of the Federal District Court, New York City, and has been fined \$2,000, for payment of money to railroad inspectors so as to facilitate the handling of eggs consigned to his concern, in violation of the interstate commerce law. In the books of the firm these payments were first entered as "graft," but when the government started the investigation into the egg damage claim frauds they were changed to something else.

#### Passes in New Jersey.

The Supreme Court of New Jersey has reversed a finding of the Public Utility Commission involving free transportation of certain state employees over the Delaware, Lackawanna & Western. In 1911 the general railroad law of the state was amended so as to give members of the Water Commission free transportation.

The Lackawanna refused to honor the passes issued under this amendment and instituted the test case, which it has now won. In the opinion Justice Garrison said:

"Once eliminate the element of public policy as the legal justification, and nothing is left but the bare fact that the subjects of free transportation are public officials, and I know of no principle of law or rule of property that will justify the taking of the property of any one of these public service corporations and handing it over to public office holders merely because they are holders of public office."

This decision will affect holders of passes on all railroads with the exception of members of the legislature and about 25 state officials who are the heads of departments. Several hundred state employees will henceforth have to pay fare.

#### The Fallaciousness of Averages.

The decision of the Supreme Court of the United States, sustaining a reduction of freight rates made by the Railroad Commission of Indiana, which was briefly noticed in our issue of October 24, page 800, is based mainly on the ground that the railroad company, in claiming that the rates prescribed by the commission were confiscatory, produced no traffic statistics to prove the claim. The Circuit Court, in deciding in favor of the railroad, had accepted statistics based on averages which really proved nothing.

The opinion, which was by Justice Hughes, is in substance as follows, slightly abridged:

The Vandalia Railroad Company had secured an injunction restraining the enforcement of an order made by the Commission on December 14, 1906, prescribing maximum freight rates for certain intrastate traffic. Members of the Commission, and the shippers who were made defendants prosecuted the appeal.

The assignments of error are addressed to the single point that the evidence failed to warrant the conclusion that the prescribed rates were so unreasonably low that, if they were maintained, the company would be deprived of its property without due process of law.

The Vandalia Railroad Company is a consolidation, effected January 1, 1905, of five railroad companies. Of these the Terre Haute & Indianapolis extended from Indianapolis westward to the boundary between the states of Indiana and Illinois, and the St. Louis, Vandalia & Terre Haute extended from that point to East St. Louis, Ill. . . . The order applied to that portion of the road which lay between Indianapolis and the western boundary of Indiana, about 80 miles. The order was limited to the freight moving on "class rates." The existing rates were found by the Commission to be unreasonably high and the maximum rates in question were ordered to be substituted as just and reasonable.

There was no proof of the value of the road's property within the State of Indiana or of the return it received from its entire intrastate business. Nor was there proof of the value of that portion of its road which was affected by the order, or of the return from all of its intrastate business upon that part of its lines. No attempt was made to supply proof of that sort. For all that appears, the Vandalia Company might enjoy, notwithstanding the enforcement of the rates in question, ample revenue from its intrastate operations to give it a fair return both as to all its lines within the State and also as to that portion to which the order referred.

The total tonnage of all kinds of freight on the 80 miles of railroad from Indianapolis to the Illinois boundary cannot be ascertained from the evidence. The amount of traffic moving on commodity rates is not shown. Evidence was adduced to show that in 1904-5-6 the new rates would have caused a large reduction in the gross revenue from that particular traffic; but the Commission found that the former rates were excessive; and the effect of this reduction upon the company's net return was to be satisfactorily proved and could not be assumed.

The conclusion in the court below was reached in the following manner. The complainant showed, and the Master found, that for the year 1904 the operating expenses upon the line between Indianapolis and the Illinois boundary were 74.50 per cent. of the whole earnings upon that line from every source, and that after consolidation, in the years 1905 and 1906, the operating expenses of the entire St. Louis division were respectively 73.03 and 72.64 per cent. of the entire earnings of that division. These ratios were then applied for the purpose of determining the expense of transporting that part of the freight which moved under class rates between stations on the road from Indianapolis to the Illinois boundary. Thus, it was assumed that, as the gross revenue from this classified freight was \$79,803 in 1904, the expense of transporting it was 74.50 per cent. of that amount or \$59,453; that, in 1905, with a gross revenue of \$91,067, the expense was 73.03 per cent. thereof or \$66,506; and that in 1906, with a gross revenue of \$102,241, the expense was 72.64 per cent. or \$74,267. According to this method of calculation, the revenue which would have been received under the order of the Commission would have been less than the expense of transportation.

It is plain, however, that it does not follow from the mere fact that the total operating expenses of a railroad, or of a division

of a railroad, bear a given relation to the entire receipts of that road or division, that the cost of transportation in the case of a particular class of traffic bears the same relation to the revenue derived from that class. The ratio, in the first case, is found by bringing together a great variety of operations involving various rates and different outlays for different sorts of traffic. It is predicated of the whole volume of business considered as such, and may be far from true of some part of it considered separately. It does not purport to be an expression of the relative cost of any specified part but simply of that of the entire traffic to which it applies.

How hazardous may be the use of such a ratio to determine the relative cost of a fragment of the business is apparent in this case. Thus it appeared that the total gross earnings of the complainant's St. Louis division in the year 1905 was \$4,750,811. Of this, the entire gross receipts from the classified freight here in question were only \$91,067, or less than 2 per cent. The expenses of the division for that year were \$3,469,544, or 73.03 per cent. of the total earnings as stated. In 1906, the earnings of the St. Louis division were \$5,480,094, and the expenses were \$3,980,906, or 72.64 per cent. These amounts embrace interstate and intrastate traffic, freight and passenger, and all freight whether moving on class or commodity rates. A large increase or reduction in the class rates on the particular intrastate freight in question, the volume of business being the same (as is the assumption), would have had a very slight effect upon the ratio of cost to earnings based on the entire operations.

The ratio of total expense to total earnings affords, in itself, no sufficient basis for determining the cost of the transportation of the particular traffic covered by the order under review. It alone furnishes no ground for invalidating the finding of the Commission that the existing rates were exorbitant and that the substituted rates would be fair. Before such a ratio could properly be used in setting forth the cost of a specified portion of the traffic, it would be necessary to have evidence either justifying the conclusion that the cost in proportion to the revenue was substantially the same for that part of the traffic as for the whole, or, if there were a material difference, satisfactorily showing its nature and extent.

In the case of *Smyth vs. Ames*, 169 U. S. 466, the legislature of Nebraska had established a classification for all intrastate freight carried by railroad and had fixed the maximum rates to be charged therefor. With other evidence, the court had before it the testimony and exhibits furnished by one of the defendants in that case, a secretary of the State Board of Transportation and a principal witness for that board, who gave the results of his investigations with respect to the traffic of each company within the State. The ratio of expense to earnings on all business done within the State was thus shown, but reliance was not placed upon that alone. That case cannot be regarded as affording basis for a contention that a ratio of expense to earnings on the entire business of a railroad, or of a division, can be taken to show the cost of some particular item or class of traffic. Each case must depend upon its special facts; and the record in the present case is barren of the necessary proof. There are certain statements with respect to the heavier cost of the operation of local as compared with through trains, but these statements are clearly inadequate. Local traffic may cost more per unit of freight movement than through traffic, but whether it cost more in proportion to revenue is another matter. That, of course, depends upon the rates charged and is a fact to be proved. There was testimony with respect to the cost of handling freight over the platform at the Indianapolis terminal, but this fell far short of the showing required, and it appeared that of the six classes of freight, to which the order applied, the fifth and sixth classes constituting much more than one-half in tonnage of the classified freight always moved in carload lots loaded by the shipper.

The evidence showed that the class rates on local traffic on the line between Indianapolis and the Illinois boundary, which were maintained by the Vandalia Company and condemned by the Commission as unreasonable, were higher than the class rates for corresponding distances to local stations in Indiana on other lines (including one of the Vandalia Company's divisions) running out of Indianapolis to the east and south. It wholly failed to sustain the contention that the action of the Commission in ordering the reduction complained of transcended the limits imposed by the Fourteenth Amendment.

## Railway Officers.

### Executive, Financial and Legal Officers.

R. G. Shorter has been appointed assistant auditor of the Georgia & Florida, with office at Augusta, Ga.

Thomas Bond has been appointed commerce counsel of the St. Louis & San Francisco, with office at St. Louis, Mo., succeeding F. H. Wood, resigned.

Fred H. Wood, general attorney and commerce counsel of the St. Louis & San Francisco at St. Louis, Mo., has been appointed general attorney and commerce counsel of the Southern Pacific Company, with headquarters at New York, succeeding James G. Wilson, resigned.

E. S. Taylor has been appointed eastern agent of the Pullman Company, with headquarters at New York, succeeding to the duties of Silas W. Bretzfield, assistant treasurer and eastern purchasing agent, who was retired under the pension rules of the company on November 1. Mr. Bretzfield was born on August 31, 1846, at New York, and entered the service of Pullman's Parlor Car Company in 1873, as private secretary to president and vice-president. He was subsequently assistant purchasing agent and then assistant treasurer and chief purchasing agent of the Pullman Company.

### Operating Officers.

H. F. Burch has been appointed trainmaster of the Delaware & Hudson, with office at Mechanicville, N. Y.

John Rourke, assistant superintendent of the Boston & Maine at Concord, N. H., has been appointed superintendent of the Portland division, succeeding C. E. McMullin, resigned.

J. T. Slattery, superintendent of the Green River division of the Denver & Rio Grande at Helper, Utah, has been appointed superintendent of the Second division, with headquarters at Salida, Colo., succeeding I. H. Luke, transferred.

Marion Johnson Wise, who has been appointed assistant to general manager of the Mobile & Ohio and the Southern Railway in Mississippi, with headquarters at Mobile, Ala., as has been

announced in these columns, was born on August 16, 1883, in St. Louis county, Missouri, and was educated in the public schools of St. Louis county. He began railway work on January 11, 1901, with the Mobile & Ohio, and from December of the same year until April, 1903, was clerk in the general manager's office; he was then until March, 1907, secretary to the general manager. From March to December, 1907, he was chief clerk to the superintendent of transportation, and then became chief clerk to the general manager of the same road. In March, 1911, he was appointed



M. J. Wise.

superintendent of the Southern Railway in Mississippi, which position he held at the time of his recent appointment as assistant to general manager of the same road, also of the Mobile & Ohio, as above noted.

R. F. Armstrong assistant superintendent of the Ashland division of the Chicago & North Western at Antigo, Wis., has been appointed superintendent of the Iowa & Minnesota division, with office at Mason City, Iowa, succeeding H. Rettinghouse, resigned to accept service with the Chicago, St. Paul, Minneapolis & Omaha. T. M. Coughlin, trainmaster at Antigo, succeeds Mr. Armstrong as assistant superintendent, and E. Doner takes the

place of Mr. Coughlin. E. E. Cunningham has been appointed trainmaster at Proviso, Ill.

Ralph F. Dawson, whose appointment as assistant superintendent of the Buffalo, Rochester & Pittsburgh, with headquarters at Du Bois, Pa., has been announced in these columns, was born on September 22, 1871, at Liberty, Ohio, and was educated in the common schools. He began railway work in January, 1888, on the Bradford division of the Erie, and the following July went to the Baltimore & Ohio as agent and operator. He was promoted the following year to copier in the train despatcher's office at Foxburg, Pa., and in January, 1890, was made train despatcher, first at Foxburg and later at Butler, until November, 1899. He then entered the service of the Buffalo, Rochester & Pittsburgh as train despatcher at Butler; one year later, he was appointed chief despatcher at Butler. He was later transferred in the same capacity to Punxsutawney and then to Du Bois, remaining in that position until October 1, 1913, when he was appointed assistant superintendent of the same road, as above noted.

James D. Tyter, whose appointment as general superintendent of the Boston & Maine, with headquarters at Boston, Mass., has been announced in these columns, was born on August 1, 1864, at Gilboa, N. H., and began railway work as a water boy with a construction crew. In 1880 he was put in charge of a construction crew. He was soon promoted to freight brakeman and then successively to places as passenger brakeman, fireman, conductor and agent. In 1888 he was appointed general yardmaster at Worcester, Mass.; and in 1891 was promoted to general yardmaster at Williamstown, which at that time was the largest yard on the Fitchburg division. In 1896 Mr. Tyter was transferred in the same capacity to Boston, and subsequently was general yardmaster of the North Station. On January 1, 1905, he was appointed assistant superintendent of the Terminal division. He was made assistant superintendent of the Fitchburg division, in December, 1907, in charge of lines west of East Deerfield, and on November 1, 1911, was promoted to assistant superintendent of the entire division. He was made superintendent of the division in November, 1912, and this position he held at the time of his recent appointment as general superintendent, as above noted. His entire service has been on the Boston & Maine lines.



J. D. Tyter.

#### Traffic Officers.

W. H. Chevers has been appointed general agent of the Union Pacific and Oregon Short Line at Ogden, Utah.

W. F. Van Norte has been appointed traffic manager of the Ashley, Drew & Northern, with office at Crossett, Ark.

W. W. Avery has been appointed assistant general passenger agent of the Kansas City Southern, with headquarters at Kansas City, Mo.

H. H. Pierce has been appointed traveling freight agent of the Hocking Valley, with office at Columbus, Ohio, in place of W. H. Hartsough.

D. M. Bowman has been appointed assistant general passenger agent of the Cleveland, Cincinnati, Chicago & St. Louis, with headquarters at Cincinnati, Ohio.

J. B. Baird, general freight agent of the Northern Pacific, has been appointed freight traffic manager, with headquarters at St. Paul, Minn., effective November 1.

William J. Smith has been appointed traveling freight and passenger agent of the El Paso & Southwestern and the Morenci Southern, with headquarters at New York City.

A. A. Boyle, traveling freight agent of the Missouri Pacific, with headquarters at New Orleans, La., has been appointed commercial agent of the Missouri & North Arkansas at New Orleans, succeeding T. F. Ellzey, resigned.

Wilfred S. R. Cameron, traveling agent of the Chicago, St. Paul, Minneapolis & Omaha at Vancouver, B. C., has been appointed general agent, with office at Winnipeg, Man., succeeding H. M. McGinnis, resigned, and Edward A. Dye succeeds Mr. Cameron.

John S. Talbot has been appointed general agent of the Chicago & North Western at Indianapolis, Ind., succeeding J. J. Livingston, transferred. Mr. Talbot was formerly for a number of years connected with the North Western, and more recently was general agent of the Western Maryland at Chicago.

E. R. Eudaly has been appointed agent of livestock, dairy and poultry division of the freight traffic department of the Queen & Crescent Route, with headquarters at Chattanooga, Tenn. He will have charge of the work of developing the livestock, dairy and poultry industry along the lines of the Cincinnati, New Orleans & Texas Pacific and the Alabama Great Southern.

D. L. Moorman, traveling passenger agent of the Cincinnati, Hamilton & Dayton, with headquarters at Toledo, Ohio, has been appointed Northern passenger agent at Detroit, Mich., succeeding J. Lee Barrett, resigned. B. M. McNeff, traveling passenger agent, with office at Dayton, Ohio, succeeds Mr. Moorman, and Mr. McNeff is succeeded by F. B. Dickinson, heretofore city ticket agent at Dayton.

D. G. Gray, general western freight agent of the Western Maryland of Pittsburgh, Pa., has been appointed general freight agent, with headquarters at Baltimore, Md. M. H. Jacobs, general agent at Pittsburgh, has been promoted to assistant general freight agent, with headquarters at Pittsburgh. S. J. Lamoreaux, general agent at Cleveland, Ohio, succeeds Mr. Jacobs, and Brent Arnold, Jr., general agent at Cincinnati, succeeds Mr. Lamoreaux.

C. A. Bencoter, assistant general passenger agent of the Southern Railway, at Chattanooga, Tenn., has been transferred to Knoxville. John L. Meek, assistant general passenger agent at Atlanta, Ga., has been transferred to Chattanooga, succeeding Mr. Bencoter; J. C. Beam, assistant general passenger agent at St. Louis, Mo., has been transferred to Atlanta, succeeding Mr. Meek, and F. N. Westerman, chief clerk in the passenger department at Washington, D. C., has been promoted to assistant general passenger agent, succeeding Mr. Beam.

J. W. Rhodes, assistant commercial agent of the Illinois Central at Chicago, has been appointed export and import agent, with headquarters at Chicago, succeeding C. A. Florence, deceased. L. W. Hazlehurst, commercial agent at Evansville, Ind., succeeds Mr. Rhodes; B. T. Breckenridge, commercial agent at Indianapolis, Ind., takes the place of Mr. Hazlehurst, and B. W. Fredenburg succeeds Mr. Breckenridge. H. E. Shutt has been appointed contracting freight agent at Detroit, Mich., succeeding W. C. Pfeifer, who has been made traveling freight agent at Detroit in place of B. W. Fredenburg.

M. H. Jacobs, who has been appointed assistant general freight agent of the Western Maryland, with headquarters at Pittsburgh, Pa., was born on August 12, 1877, at Waynesboro, Pa., and was educated in the public schools. He began railway work on October 1, 1893, as a messenger boy on the Western Maryland at York, Pa., and in December, 1900, was transferred to the commercial freight agent's office of the same road at Baltimore, Md. In February, 1904, he was made soliciting freight agent and subsequently became traveling freight agent at the same place. He was appointed general agent with headquarters at Pittsburgh, Pa., in August, 1912, which position he held at the time of his recent appointment as assistant general freight agent of the same road as above noted.

H. B. Rogers, freight soliciting agent of the Southern Railway, at Norfolk, Va., has been appointed commercial agent, with office at Norfolk, and the freight soliciting agency at Nor-

folk has been discontinued. C. W. Westbury, district passenger agent at Philadelphia, Pa., has been appointed assistant general agent, with headquarters at Washington, D. C. S. E. Burgess, division passenger agent at Richmond, Va., has been appointed division passenger agent at Philadelphia, succeeding Mr. Westbury. H. L. Bishop, passenger agent at Washington, D. C., has been appointed division passenger agent with office at Richmond, Va., succeeding Mr. Burgess, and John T. Richmond, succeeds Mr. Bishop. G. A. Fisher, traveling passenger agent at Memphis, Tenn., has been transferred in the same capacity to Cleveland, Ohio, succeeding C. R. Chesney, resigned to go into other business. P. N. Estes, city passenger and ticket agent at Columbus, Ga., succeeds Mr. Fisher, and R. G. Parish succeeds Mr. Estes.

**Engineering and Rolling Stock Officers.**

George H. Funk, formerly superintendent of fuel economy of the Chesapeake & Ohio, has been appointed chief smoke inspector for all the railroads entering Cincinnati, Ohio.

W. J. Frey has been appointed supervisor of materials of the Lake Shore & Michigan Southern, with headquarters at Cleveland, Ohio, succeeding H. W. Gardner, resigned.

A. B. Warner, vice-president and general superintendent of the Chicago, Rock Island & Gulf, has been appointed, also, chief engineer, with headquarters at Ft. Worth, Tex., succeeding H. M. Stone, resigned.

A. F. Blaess, district engineer of the Illinois Central, at Memphis, Tenn., has been transferred to Chicago as district engineer, succeeding James Clifford, resigned, and D. W. Thrower, assistant engineer maintenance of way at Chicago, has been promoted to district engineer at Memphis, succeeding Mr. Blaess.

Hugh D. Mackenzie, whose appointment as division master mechanic of the Intercolonial Railway, with headquarters at Stellarton, N. S., has already been announced in these columns,



H. D. Mackenzie.

was born on July 22, 1864, at Churchville, Pictou county, N. S., and was educated in the public schools of Moncton, N. B. He began railway work on July 24, 1881, with the Intercolonial Railway as a machinist apprentice, remaining in that position until 1886, and then for twelve years was machinist. He was appointed charge hand at Moncton, N. B., in 1898, and the following year became mechanical foreman at Stellarton, N. S., remaining in that position until 1909, when he was appointed general locomotive foreman at Moncton, N. B., which position he held at the

time of his recent appointment, as division master mechanic, with headquarters at Stellarton, N. S., of the same road, as above noted.

Walter U. Appleton, whose appointment as general master mechanic of the Intercolonial and the Prince Edward Island railways, with headquarters at Moncton, N. B., has been announced in these columns, was born on January 29, 1878, at Moncton, and was educated in the public schools. He began railway work on October 13, 1890, with the Canadian Government Railways as a junior clerk. From 1895 to 1899 he was apprentice machinist and then was clerk, for one year, becoming machinist in 1901. Two years later he was made chief clerk to the superintendent of motive power, remaining in that position until 1907. He was appointed assistant to superintendent of motive power on the Intercolonial in 1909, which position he held at the time of his recent appointment as general master mechanic, as above noted.

George Edward Smart, who has been appointed master car builder of the Intercolonial and the Prince Edward Island railways, with headquarters at Moncton, N. B., as has been announced in these columns, was born on December 23, 1873, at Edinburgh, Scotland, and was educated in the public schools. He began railway work in August, 1893, with the Grand Trunk, and held various positions on that road until 1897, when he was promoted to car inspector. From 1904, to 1906, he was general inspector of heating and lighting on the eastern lines of the Canadian Pacific, and then to 1909, was general car inspector on the eastern lines of the same road. In 1909 he was made division car foreman in charge of passenger and freight car work on the eastern division of the Canadian Pacific, which position he held at the time of his recent appointment as master car builder of the Canadian government railways as above noted.

**OBITUARY.**

Frederick A. Haskell, formerly general freight agent of the New York Central & Hudson River, died on November 3 at his home in Brooklyn, N. Y.

William G. Gordon, assistant auditor of the treasury department of the Chicago, Burlington & Quincy, at Chicago, died at his home at Hinsdale, Ill., on November 1.

Jacob Johann, from 1892 to 1897 superintendent of machinery of the Chicago & Alton, died recently at his home in Springfield, Ill. He was born at Rheinabern, Bavaria, Germany, on November 15, 1830. He began railway work in November, 1858, and to July, 1861, was assistant to master mechanic on the Missouri Pacific, subsequently for about four years he was master mechanic in shops on the Southwest branch at Pacific City, Mo. From March, 1865, to May, 1868, he was general master mechanic of the Missouri Pacific, and from April, 1870, to January, 1872, held the same position on that road. In October, 1872, he was appointed general master mechanic of the Chicago & Canada Southern, and from June, 1874, to November, 1884, was general master mechanic of the Wabash, St. Louis & Pacific, and then to May of the following year was superintendent of motive power and machinery of the same road. From July to November, 1885 he was master mechanic of the Missouri, Iowa & Nebraska, now part of the Chicago, Burlington & Quincy, and then to December, 1886, was master mechanic of the Chicago & Atlantic, now part of the Erie. He was appointed superintendent of motive power and rolling stock of the Texas & Pacific at Marshall, Tex., in December, 1886, remaining in that position until June, 1888; subsequently he had charge of the Chicago office of the Safety Car Heating & Lighting Company, and from November 5, 1892, to February, 1897, he was superintendent of machinery of the Chicago & Alton. Previous to entering railway service he was for 12 years employed in various locomotive work.

DEMURRAGE IN ENGLAND.—As the result of several conferences between representatives of the railway companies and of the shippers affected, the regulations regarding the enforcement of demurrage charges for detention of freight cars, which came into force on English and Welsh railways at the beginning of the present year, have been modified to the extent of enlarging the free period at private sidings. For general traffic the January regulations allow a free period, before conveyance, of one day exclusive of the day on which loading is begun; this free period has now been extended to two days, exclusive of the day on which loading is begun, while the free period after conveyance is now to be three days instead of two, exclusive of the day of arrival. In the case of traffic for shipment two free days, instead of one day, are now allowed before conveyance, and after conveyance four days, whereas, under the January regulations, only two days were allowed for coastwise shipment traffic and four days for foreign shipment traffic. The new arrangement as to shipment traffic is, however, subject to the proviso that the term coastwise does not include traffic delivered to barge or other craft for works or wharves within the port area, and that the South-Eastern & Chatham Railway only allows two days, exclusive of day of arrival, on coastwise shipment traffic. The charges on expiry of the respective free periods remain at 36 cents per car per day for ordinary freight cars.

## Equipment and Supplies.

### LOCOMOTIVE BUILDING.

THE SKANEATELES RAILWAY has ordered one six-wheel switching locomotive from the American Locomotive Company. The dimensions of the cylinders will be 19 in. x 26 in., the diameter of the driving wheels will be 50 in., and the total weight in working order will be 132,000 lbs. The steam pressure will be 180 lbs.

THE CHICAGO, ST. PAUL, MINNEAPOLIS & OMAHA has ordered 4 Pacific type locomotives and 6 mikado locomotives from the American Locomotive Company. The Pacific type locomotives will have 25 in. x 28 in. cylinders, 75 in. driving wheels, a steam pressure of 170 lbs., and in working order will weigh 260,000 lbs. The mikado locomotives will have 27 in. x 32 in. cylinders, 61 in. driving wheels, a steam pressure of 170 lbs., and in working order will weigh 300,000 lbs.

### CAR BUILDING.

THE CHICAGO, MILWAUKEE & ST. PAUL has ordered 3 private cars from the Pullman Company.

THE NORTHERN PACIFIC is said to be in the market for 250 ore cars. This item has not been confirmed.

THE MINNEAPOLIS, ST. PAUL & SAULT STE. MARIE is in the market for 6 coaches, 2 parlor cars and 2 buffet observation cars.

THE LEHIGH VALLEY is in the market for 1,000 fifty-ton hopper cars, about 75 coaches and about 25 combination baggage and express cars.

### IRON AND STEEL.

THE PIERRE MARQUETTE has ordered 2,000 tons of rails from the Illinois Steel Company.

THE PAULISTA RAILWAY, Brazil, has ordered 3,000 tons of rails from the United States Steel Products Company.

THE ATLANTIC COAST LINE has ordered 15,000 tons of rails for 1914 requirements from the Tennessee Coal, Iron & Railroad Company.

THE PHILADELPHIA & READING has divided an order for 24,000 tons of rails for 1914 requirements between the Bethlehem Steel Company, the Carnegie Steel Company, the Lackawanna Steel Company and the Pennsylvania Steel Company.

**GENERAL CONDITIONS IN STEEL.**—The steel industry continues to be very dull, with a declining tendency in both orders and prices, and continued smaller production at the mills. In general, however, manufacturers are inclined to be rather optimistic. Many contend that the present condition represents only a temporary lull. Most steel mills in the East are operating at from 60 to 75 per cent. of capacity, but large mills in the Central West are operating at about 85 per cent. capacity. With the present market conditions further recessions in operations are expected before the end of the month.

### SIGNALING.

The Philadelphia & Reading is installing automatic block signals on its line between Port Clinton, Pa., and Buck Mountain, 30 miles, double track. The signals are Hall enclosed disks. At present the telegraph block system is in use on this part of the line.

**SPANISH RAILWAY CONTRACTS.**—The contract for constructing section 6 of the railway from Ripoll to Puigcerda has been awarded to Lorenzo Sunier, Barcelona, at \$304,252. No bids were submitted September 2 for completing construction on the railway from Bocaleones to Malaga.

## Supply Trade News.

The J. Faessler Manufacturing Company, Moberly, Mo., has moved its St. Louis, Mo., office from 810 Olive street to the Railway Exchange building.

Charles A. Eggert, who for the past 12 years has been with the Consolidated Car Heating Company, has been made sales engineer of the Railway Utility Company, Chicago.

Ashmead Gray Rodgers, for 12 years superintendent of the Carborundum Company's plant at Niagara Falls, N. Y., died on October 23, as the result of injuries sustained through an accident on October 5. Mr. Rodgers was a native of Albany, N. Y., having been born there in 1872. Previous to his coming to the Carborundum Company as superintendent he was superintendent of the Eddy Electrical Company, Hartford, Conn. His funeral services were held at Niagara Falls on Saturday, October 25, from St. Peter's Church, and were attended by several hundred of the employees of the Carborundum Company, members of the Niagara Club and other friends. Mr. Rodgers was a member of the American Chemical Society, Engineers' Society of New York, Chemists' Club, Niagara Club, University Club and Country Club of Niagara Falls.

The Union Switch & Signal Company recently gave a dinner to its veterans at the Fort Pitt hotel, Pittsburgh, Pa. There are 87 men who have been in the employ of the company 21 years or more. Of these, 83 were present at the dinner. Two of the absent ones were too far away, and two were too ill to attend. Of the 87 veterans 53 are stockholders in the company, their holdings being worth \$140,000 in the market today. They have been leaders in a beneficial association which has been in existence many years, has paid out large sums of money in sick and death benefits and has never been helped financially by the company. These veterans, too, have been the backbone of a shop loan association, established in recent years, to keep the employees out of the hands of the loan sharks. This association is run entirely with capital subscribed by the men and is not helped financially by the company.

H. E. Gifford, Jr., has been appointed sales manager for the National Electric Specialty Company, Toledo, O., effective November 1. He resigned as Western representative of the L. S. Brach Supply Company to accept this position, with headquarters in Chicago. Mr. Gifford has been in the signal business since 1905, when he went to work for the New York Central at Mott Haven, N. Y., as an accountant in the office from which the Electric Zone work was handled. In May, 1906, he was appointed chief clerk to Azel Ames, then signal engineer of the N. Y. C. Electric Zone. In 1907, when the organization was disbanded, he went into the accounting department of the Union Switch & Signal Company's Pennsylvania terminal construction department. In 1910 he entered the employ of the American Conduit Company and was later connected with the installation of the underground conduit system of the New York, Westchester & Boston. He went to the L. S. Brach Supply Company in January, 1912.

The annual convention of the district managers and salesmen of the Sherwin-Williams Company, Cleveland, was held at the Auditorium hotel, Chicago, October 27-29, and was attended by some 75 representatives of the company. Details for the interesting event were arranged by Adrian B. Joyce, general manager; H. M. Ashby, district manager; S. H. Stewart, sales manager, and Thomas Madill, manager western railroad department. The various meetings were presided over by Mr. Ashby, Mr. Stewart and Clyde E. Horton, manager of the publicity and promotion department. Plans for increased efficiency and sales promotion were discussed, and the company's literature, from its own printing plant and presses, was shown and commented on. The feature of the gathering was a display of motion pictures showing the operations of the "Brighten-Up Club" (a Sherwin-Williams organization) in a typical country town. The films will be exhibited throughout the country. A banquet at the Chicago Athletic Association on Wednesday night, arranged by L. B. Quinn, chairman of the entertainment committee, and presided over by Mr. Joyce as toastmaster, closed the convention.

## Railway Construction.

**CANADIAN PACIFIC.**—Application has been made to the Canadian parliament for an extension of time to build the following lines: From or near Hawarden to a point at or near Floral or Cheviot, Sask.; from or near Sedgwick southerly to a point in township 39 or 40, range 11, 12 or 13, west 4th meridian, Alta.; from a point on the Wilkie branch to a point near the North Saskatchewan river in township 51 or 52, range 1 or 2, west 4th meridian in Saskatchewan and Alberta; from the north-westerly terminus of the Asquith branch to a point at or near Battleford, Sask.; from a point at or near Irricana to a point in township 20 or 21, range 11 to 14, west 4th meridian, Alb., and from Killam to Strathcona, Alta.

**CHICAGO, BURLINGTON & QUINCY.**—The report of this company for the year ended June 30, 1913, shows that on the extension from Thermopolis, Wyo., east to Powder River the bridge work and grading were completed, and on the section from Powder River to Orin Junction grading work and bridge construction was continued, and some of the right of way was secured. All the work has been finished west of Casper, and the company expects next year to continue the construction work through to Orin Junction to complete the entire line. No work was carried out on the Hudson-Greeley line, in Colorado except to secure some of the right of way. Additional land was bought during the year for needed facilities in Chicago, in Aurora, in Denver and at other places. The company placed in operation during the year 58.46 miles of additional second track and 74.54 miles of yard tracks and sidings. A new yard was built at Eola, Ill., containing six tracks having a total length of about 4,000 ft., together with necessary water and coal stations. The existing third track from Chicago to Belmont, Ill., is being extended to Aurora, and for a distance of about nine miles north of Keokuk, Iowa, the tracks have been raised and rebuilt to place them above the flow line caused by the new power dam across the Mississippi river at that point. The company spends a large amount of money each year in protecting the lines from the encroachment of the Missouri river at Folsom, Iowa. The tracks between Pacific Junction and Council Bluffs have been protected for about two miles with heavy revetment work, and this work is being carried out on one mile additional to hold the bed of the river in its course and protect the east approach of the company's bridge over the Missouri river near Plattsmouth.

**DES QUINZE & BLANCHE RIVER.**—This company has applied to the Canadian parliament for an extension of time to build from Dymond, on the Temiskaming & Northern Ontario to the mouth of the Des Quinze river, thence to Des Quinze lake in the province of Quebec. The Bronson Company, Ottawa, Ont., are the contractors, also the owners through a subsidiary company. Some construction work has already been carried out.

**INTERCOLONIAL RAILWAY.**—This company is asking for bids November 10, for building from North Sydney, N. S., to Leitches Creek.

**NAVAJO SOUTHERN.**—This company which was organized last year has given a contract to the L. J. Smith Construction Company, it is said, to build from Holbrook, Ariz., south through a lumber and mining section for a distance of about 80 miles. F. H. Bowen, president; W. H. Clark, secretary; R. W. Hill, treasurer, and E. S. Clark, counsel.

**NEW YORK SUBWAYS.**—The New York Public Service Commission, First district, is asking for bids for the construction of three sections of the new subway and elevated lines in the borough of the Bronx, as follows: On November 26, for a section of the White Plains road extension of the existing subway, known as Section No. 2 of Route No. 18, in White Plains road, between Burke avenue and East 241st street. This is to be an elevated line with three tracks; bids are wanted on November 28, for the Jerome avenue section, known as Section No. 1 of Route No. 16, which will be mainly in Jerome avenue, between 157th street and River avenue and East 182d street. This will also be a three track elevated line and will join the subway now being constructed south of 157th street; bids are wanted on December 1 for work on the Southern Boulevard

branch, known as Section No. 1-A of Routes Nos. 19 and 22. This is to be built in Southern boulevard and Whitlock avenue, between East 147th street and Bancroft street. It is to be a three track underground line as far north as a point in Whitlock avenue between Aldus and Bancroft streets, from which point north it is to be an elevated structure.

The commission is asking for bids on November 21, for building Section No. 2 of Route No. 39, the New Utrecht avenue branch of the Fourth avenue subway in the borough of Brooklyn. This section is from a point near the intersection of Tenth avenue and Thirty-ninth street, Brooklyn, and will be built as an elevated line over Tenth avenue to New Utrecht avenue, thence over New Utrecht avenue and other streets and private property to Eighty-sixth street, and over Eighty-sixth street to a point near Bay Forty-first street, thence over Stillwell avenue to a point just north of Avenue Y, where a connection will be made with the Sea Beach line to Coney Island. The line will be a three track elevated structure, and will be operated by the New York Municipal Railway Corporation in connection with the Fourth avenue subway.

**PETERSBURG & COLUMBIA SPRINGS.**—Incorporated in West Virginia with \$25,000 capital and headquarters at Fairmont, to build from a point near Petersburg, in Grant county, W. Va., southwest to Columbia Sulphur Springs, in Greenbrier county, about 100 miles. The incorporators include A. R. Watson, M. C. Hite, L. Bailey, J. F. Hite and R. L. Long, of Fairmont.

**SUDBURY, KEPAWA & BELL RIVER.**—Application has been made in Canada for incorporation to build railway lines from Sudbury, Ont., in a generally eastern direction to the south end of Lake Temiskaming, thence northeasterly to the National Transcontinental in the province of Quebec, where the National Transcontinental crosses the Bell river. John Thompson, Ottawa, Ont., is solicitor for the applicants.

**TEMPLE, NORTHWESTERN & GULF.**—A franchise has been granted by the Temple, Tex., city council permitting this company to enter the city, and construction work on the line, which has been held up for two months pending the granting of the franchise, will be renewed. The line will parallel the tracks of the Santa Fe road into Temple. The company was organized some time ago to build from Temple, northwest via Gatesville and Hamilton, about four miles of track has been laid. It is understood that an extension is to be built east to a connection with the Missouri, Kansas & Texas, at Trinity, about 120 miles. (August 29, p. 396.)

**UNGAVA RAILWAY.**—Application has been made in Canada for incorporation to build from the Hudson's Bay Company's post at the mouth of the Great Whale river, or from a point between the mouth of the Great Whale river and the mouth of the Nastapoka river on the eastern coast of Hudson Bay, thence easterly or southeasterly to Aylmer sound on the Gulf of St. Lawrence, or to some other feasible point on the gulf. Pentland, Stuart, Gravel & Thomson, Ottawa, Ont., are solicitors for applicants.

### RAILWAY STRUCTURES.

**BATHURST, N. B.**—An officer of the Intercolonial Railway writes that work on the new station at Bathurst is nearing completion. It is a brick building with stone trimmings 75 ft. long x 24 ft. wide. (October 17, p. 728.)

**BAY CITY, MICH.**—The Michigan Central has announced that work is to be started shortly on the erection of car shops and a new freight house at this place.

**OTTUMWA, IOWA.**—The Chicago, Burlington & Quincy during the fiscal year ended June 30, 1913, put in service new freight houses at Ottumwa, Iowa, at Des Moines and at St. Joseph, Mo., also a new general office building at Chicago.

**TRURO, N. S.**—An officer of the Intercolonial Railway writes that work on the new station at Truro is about finished. The walls are of red stone with dressed trimmings. The central part of the building is 115 ft. 8 in. long x 24 ft. wide, two stories high, with offices on the second floor. There is a one story portion at each end of the main building, one 80 ft. long x 50 ft. wide, and the other 122 ft. long x 50 ft. wide. (October 17, p. 728.)

## Railway Financial News.

**ALABAMA GREAT SOUTHERN.**—Stockholders are to vote on November 26 on authorizing a mortgage to secure \$25,000,000 bonds.

**ATCHISON, TOPEKA & SANTA FE.**—This company has leased the Port Bolivar Iron Ore Railway, which runs from Longview, Tex., through Ore City to the mines, in all about 36 miles.

**ATLANTA, BIRMINGHAM & ATLANTIC.**—The resignation of H. M. Atkinson as co-receiver with E. T. Lamb has been accepted; and Mr. Lamb is now sole receiver.

**BANGOR & AROOSTOOK.**—Charles A. Milliken, of Augusta, Maine, has been elected a director, succeeding Arthur Holland, of Concord, Mass.

**BUFFALO & SUSQUEHANNA RAILROAD.**—This road is to be sold under foreclosure on December 4.

**CHICAGO & NORTH WESTERN.**—All of the \$10,000,000 first mortgage 5 per cent. bonds of the St. Louis, Peoria & Northwestern, guaranteed principal and interest by the Chicago & North Western, offered by Kuhn, Loeb & Co., New York, were almost immediately sold.

**CHICAGO, ROCK ISLAND & PACIFIC.**—Effective on November 1, this company, as lessee, took over and will operate as part of its own line the St. Paul & Kansas City Short Line.

**FAIRMOUNT & VEULEN.**—This road, just financed by the farmers along the line, has begun operation. The road runs from Fairmount, N. D., to Veulen, S. D., about 37 miles.

**HOCKING VALLEY.**—The \$4,000,000 one-year 5 per cent. notes which were approved of by the Public Utilities Commission of Ohio, as mentioned in these columns last week, have been sold through Kuhn, Loeb & Co. and the National City Bank, both of New York, at 99½.

**MEXICAN RAILWAY.**—A semi-annual dividend of 1¼ per cent. has been declared on the ordinary stock for the half year ended June 30, 1913. This is the same rate as was paid in the previous half year, making the total yearly payment 2½ per cent., compared with 3¾ per cent. paid in the previous year.

**MIDDLETOWN, UNIONVILLE & WATER GAP.**—This road has been sold under foreclosure to a bondholders' committee representing first and second mortgage bondholders. It has heretofore been operated by the New York, Susquehanna & Western, but, it is understood, will now be operated as an independent property.

**NEW YORK CENTRAL & HUDSON RIVER.**—The entire issue of \$12,000,000 one-year 5 per cent. notes of the New York Central & Hudson River, which J. P. Morgan & Co., New York, offered at 99½, were sold on the morning of the day of offering.

**NEW YORK, SUSQUEHANNA & WESTERN.**—See Middletown, Unionville & Water Gap.

**PACIFIC RAILWAYS OF NICARAGUA.**—Brown Brothers & Co. and J. & W. Seligman & Co., both of New York, have bought from the Republic of Nicaragua 51 per cent. of the stock of the Pacific Railways of Nicaragua, incorporated under the laws of Maine. The railway company is the only one operating in Nicaragua and runs from Corinto, on the Pacific coast, to Managua and Granada, with branches, about 165 miles. The road has been operated under the management of J. G. White & Co., in New York, who will continue to be in charge of the active operation.

**PORT BOLIVAR IRON ORE RAILWAY.**—See Atchison, Topeka & Santa Fe.

**ST. LOUIS & SAN FRANCISCO.**—Charles H. Sabin, vice-president of the Guaranty Trust Company, New York, and chairman of the stockholders' protective committee of the St. Louis & San Francisco, has written a letter to stockholders which says in part:

"The annual meeting of the stockholders of the 'Frisco will be held in St. Louis, November 10. Some stockholders have solicited proxies for that meeting.

"We have not thought it necessary to concern ourselves particularly over the election of a board of directors which will

be without power, and whose duties will be perfunctory, so long as the property is in the hands of receivers appointed by the court.

"The receivers appointed by Judge Sanborn are operating the road and managing the property satisfactorily, and the results obtained by them show a decided improvement. Under their administration it has been practicable to provide for the interest due November 1 on the general lien 5 per cent. bonds outstanding. The court has authorized this payment and the issuance, from time to time, of a total of \$10,000,000 receivers' certificates to meet prior claims and provide for necessary improvements, subject to the approval of the court as to application of proceeds.

"The early rehabilitation or reorganization of the property would not seem to be impossible. It will, however, require a considerable amount of new money. The purpose of this committee is, either to devise some plan, or to assist in the carrying out of some plan for the rehabilitation or reorganization of the property which will conserve the rights and interests of the stockholders.

"The committee does not believe that any plan can be made acceptable to the large body of security holders, or can be effectively carried out unless coincidentally the board of directors shall be changed and so constituted as to command the confidence of the stockholders and bondholders, and of the investing public generally.

"Thus far, all we have asked of the stockholders is that they should pledge their stock under an agreement which does not commit them to the payment of any money or debar them from the sale of their stock."

**ST. LOUIS, PEORIA & NORTHWESTERN.**—See Chicago & North Western.

**TOLEDO, ST. LOUIS & WESTERN.**—C. Pilz, a stockholder, has sent out a circular protesting against the Toledo, St. Louis & Western investment in Chicago & Alton.

**UNION PACIFIC.**—*The Commercial & Financial Chronicle* says that about \$80,000,000 has so far been received from the sale of the \$88,357,000 certificates of interest in the Southern Pacific. Almost the entire amount has been invested in short term securities, mostly one-year notes.

**EMPLOYEES' WAGES IN AUSTRALIA.**—Although the Acting Premier of Australia was disinclined to make any pronouncement regarding what action the government proposed to take in relation to the minimum wage question as affecting railway employees, it is practically certain that now the Premier has returned arrangements will be made with the Railway Commissioners to increase the rate to \$2 a day. The Railway Commissioners prefer to be silent on the point, but from a reliable source it has been ascertained that they are fully convinced that \$2 a day is by no means an extravagant wage. The increase will mean a considerable addition to the operating expenses of the railways, and it is not improbable that a corresponding increase in fares and freight rates will have to be made to meet the situation.

**ENCOURAGING RAILWAY EXTENSIONS IN ENGLAND.**—On the Belfast & Northern Counties Railway, before it was absorbed by the Midland, there was, and perhaps still is, an arrangement to encourage suburban travel. To certain undeveloped areas the company gave a free season-ticket to and from Belfast for all the heads of households who owned and resided in houses of a certain rental. Now something on the same lines has been done in connection with the extension from Ponteland, on the North-Eastern Railway, to Darras Hall. Darras Hall is a communal estate, acquired and developed by the Northern Allotment Society of Newcastle-on-Tyne, and consists of nearly 1,000 acres, laid out into parcels of 5 acres each, and divided by broad tar-macadamed roads running north and south and east and west, each lot fronting upon a roadway. Practically every lot has been disposed of. The railway extension has cost the North-Eastern \$45,000, and it is to receive from the estate a perpetual rent of \$1,800, but this sum is to be reduced in proportion as each lot has its house occupied, as the owner of the house will then begin to travel and so bring traffic to the line, and therefore his share of the rent is not to be paid.

# ANNUAL REPORT.

## CHICAGO, BURLINGTON & QUINCY RAILROAD COMPANY—FIFTY-NINTH ANNUAL REPORT.

Chicago, July 1, 1913.

To the Stockholders of the Chicago, Burlington & Quincy Railroad Company:

The following is the report of your Board of Directors for the year ended June 30, 1913:

### CHICAGO, BURLINGTON & QUINCY RAILROAD COMPANY. YEARS ENDED JUNE 30.

Per Cent.	1913.	OPERATING REVENUES.	1912.	Per Cent.
67.88	\$64,063,856.49	Freight Revenue	\$57,740,418.62	66.58
23.20	21,895,690.73	Passenger Revenue	21,083,418.74	24.31
2.47	2,329,351.41	Mail Revenue	2,368,447.34	2.73
3.07	2,894,812.78	Express Revenue	2,578,810.37	2.98
		Miscellaneous Transportation Revenue		
2.28	2,146,658.47	Revenue from Operations other than Transportation	2,031,281.77	2.34
.96	909,376.59	Joint Facilities	788,588.94	.91
.14	134,739.04		132,102.19	.15
100.00	\$94,374,485.51	Total Operating Revenue	\$86,723,067.97	100.00
		OPERATING EXPENSES.		
		Maintenance of Way and Structures	\$13,541,030.39	15.61
13.28	\$12,535,862.55	Maintenance of Equipment	14,294,032.69	16.48
17.10	16,133,215.36	Traffic Expenses	1,528,114.63	1.76
1.68	1,586,802.81	Transportation Expenses	29,020,384.11	33.47
31.79	29,997,717.32	General Expenses	2,263,387.34	2.61
2.74	2,589,292.99			
66.59	\$62,842,891.03	Total Operating Expenses	\$60,646,949.16	69.93
33.41	\$31,531,594.48	Net Operating Revenue	\$26,076,118.81	30.07
	127,691.01	Net Deficit from Outside Operations	122,700.51	
	\$31,403,903.47	Total Net Revenue	\$25,953,418.30	
	3,563,358.62	Taxes Accrued	3,303,058.11	
	\$27,840,544.85	Operating Income	\$22,650,360.19	
		OTHER INCOME.		
	\$ 632,910.23	Rents	\$ 614,749.50	
	1,327,019.67	Miscellaneous Interest	1,536,294.65	
	\$ 1,959,929.90	Total Other Income	\$ 2,151,044.15	
	\$29,800,474.75	Gross Corporate Income	\$24,801,404.34	
		DEDUCTIONS FROM GROSS CORPORATE INCOME.		
	\$ 1,158,071.87	Rents	\$ 1,469,055.04	
	305.52	Miscellaneous Interest	13,493.46	
	8,546,453.42	Interest Accrued on Funded Debt	8,547,309.04	
	655,450.28	Sinking Funds	657,978.58	
	9,447.77	Discount on Funded Debt	6,814.44	
	\$10,369,728.86	Total Deductions	\$10,694,650.56	
	\$19,430,745.89	Net Corporate Income	\$14,106,753.78	
	\$ 8,867,128.00	Dividends	\$ 8,867,128.00	
	7,647,743.21	Appropriations for Betterments	3,944,216.08	
	\$16,514,871.21		\$12,811,344.08	
	\$ 2,915,874.68	Surplus for the Year	\$ 1,295,409.70	

### CAPITALIZATION: CAPITAL STOCK.

Number of Shares.	Total Par Value Authorized and Outstanding.	Dividends Declared During the Year.			
		Rate. %	Amount.		
1,108,391	\$110,839,100.00		\$8,867,128.00		
		FUNDED DEBT.			
		Total Par Value.			
		In Treasury, in Sinking Funds or Pledged as Collateral.	Interest Accrued During Year.		
Description of Bond.	Authorized.	Outstanding.	In Hands of Public.	Interest Accrued During Year.	
Mortgage Collateral Trust	7,968,000	7,310,200	5,435,900	1,874,300	292,408.00
Plain or De-benture	13,300,000	3,667,000	3,034,000	633,000	419,121.68
Total	\$237,057,000	\$209,135,000	\$31,400,900	\$177,734,100	\$8,546,453.42

### MILEAGE.

#### MILEAGE OF ROAD OPERATED.

STATE.	Line Owned.	Operated Under Lease.	Total Line Operated.
Illinois	1,672.16	112.88	1,785.04
Iowa	1,365.09	73.47	1,438.56
Missouri	1,122.31	10.89	1,133.20
Wisconsin	222.49	.53	223.02
Minnesota	23.61	14.84	38.45
Nebraska	2,850.34	22.37	2,872.71
Kansas	259.32	.82	260.14
Colorado	394.36	34.97	429.33
South Dakota	281.48		281.48
Wyoming	482.75		482.75
Montana	134.38	49.45	183.83
Total	8,808.29	320.22	9,128.51

### LINE OWNED.

STATE.	Single Track.	Second Track.	Third Track.	Yard Track and Sidings.	Total.
Illinois	1,672.16	331.09	23.55	918.90	2,945.70
Iowa	1,365.09	244.53		330.12	1,939.74
Missouri	1,122.31	104.95		416.27	1,643.53
Wisconsin	222.49	61.31		69.41	353.21
Minnesota	23.61	2.25		30.57	56.43
Nebraska	2,850.34	17.99		686.67	3,555.00
Kansas	259.32			23.78	283.10
Colorado	394.36			128.68	523.04
South Dakota	281.48			62.73	344.21
Wyoming	482.75			151.02	633.77
Montana	134.38			35.88	170.26
Total	8,808.29	762.12	23.55	2,854.03	12,447.99

### TRAFFIC AND OPERATING STATISTICS.

ITEM.	1913.		1912.		Increase or Decrease.	
	Dollars and Whole Numbers.	Cents and Decimals.	Dollars and Whole Numbers.	Cents and Decimals.	Dollars and Whole Numbers.	Cents and Decimals.
<b>PASSENGER TRAFFIC.</b>						
Number of Passengers Carried Earning Revenue	23,100,539		22,404,120		Inc.	696,419
Number of Passengers Carried One Mile	1,139,958,615		1,100,846,373		Inc.	39,112,242
Number of Passengers Carried One Mile, per Mile of Road	125,139		121,314		Inc.	3,825
Average Distance Carried, Miles	49	35	49	14	Inc.	21
Total Passenger Revenue	\$21,895,690	73	\$21,083,418	74	Inc.	\$812,271
Average Amount Received from each Passenger		94784		94105	Inc.	00679
Average Receipts per Passenger per Mile		01921		01915	Inc.	00006
Total Passenger Service Train Revenue	\$27,820,639	23	\$26,721,933	24	Inc.	\$1,098,705
Passenger Service Train Revenue per Mile of Road	\$3,054	02	\$2,944	78	Inc.	\$109
Passenger Service Train Revenue per Train Mile	\$1	52022	\$1	46264	Inc.	05758
<b>FREIGHT TRAFFIC.</b>						
Number of Tons Carried of Freight Earning Revenue	33,389,439		30,111,513		Inc.	3,277,926
Number of Tons Carried One Mile	8,791,435,597		7,675,979,757		Inc.	1,115,455,840
Number of Tons Carried One Mile per Mile of Road	965,083		845,900		Inc.	119,183
Average Distance Haul of One Ton, Miles	263	30	254	92	Inc.	8
Total Freight Revenue	\$64,063,856	49	\$57,740,418	62	Inc.	\$6,323,437
Average Amount Received for each Ton of Freight	\$1	91869	\$1	91755	Inc.	00114
Average Receipts per Ton per Mile		00729		00752	Dec.	00023
Freight Revenue per Mile of Road	\$7,032	63	\$6,363	04	Inc.	\$669
Freight Revenue per Train Mile	\$3	52568	\$3	29282	Inc.	23286
<b>OPERATING.</b>						
Operating Revenues	\$94,374,485	51	\$86,723,067	97	Inc.	\$7,651,417
Operating Revenues per Mile of Road	\$10,360	00	\$9,556	96	Inc.	\$803
Operating Revenues per Train Mile	\$2	54737	\$2	47941	Inc.	16796
Operating Expenses	\$62,842,891	03	\$60,646,949	16	Inc.	\$2,195,941
Operating Expenses per Mile of Road	\$6,898	60	\$6,683	35	Inc.	\$215
Operating Expenses per Train Mile	\$1	76285	\$1	73389	Inc.	02896
Net Operating Revenue	\$31,531,594	48	\$26,076,118	81	Inc.	\$5,455,475
Net Operating Revenue per Mile of Road	\$3,461	40	\$2,873	61	Inc.	\$587
Net Operating Revenue per Train Mile		88452		74552	Inc.	13900
Average Number of Passengers per Car Mile	16		15		Inc.	1
Average Number of Passengers per Train Mile	62		60		Inc.	2
Average Number of Passenger Cars per Train Mile	6	23	6	19	Inc.	04
Average Number of Tons of Freight per Loaded Car Mile	19	10	18	20	Inc.	90
Average Number of Tons of Freight per Train Mile	483	83	437	75	Inc.	46
Average Number of Freight Cars per Train Mile	36	96	35	37	Inc.	1
Average Number of Loaded Cars per Train Mile	25	34	24	05	Inc.	1
Average Number of Empty Cars per Train Mile	10	66	10	36	Inc.	30
Average Mileage Operated During Year	9,109	51	9,074	34	Inc.	35

\*Including Caboose.



EXPENDITURES FOR NEW LINES AND EXTENSIONS, FOR EQUIPMENT, AND FOR ADDITIONS AND BETTERMENTS, DURING THE YEAR.

ACCOUNT.	Additions and Betterments.			Total Expenditure.
	New Lines and Extensions.	Charged to Road and Equipment.	Charged to Income.	
<b>I.—ROAD.</b>				
Engineering .....	\$ 35,467.83	\$ 37,110.72	\$ 46,297.71	\$ 118,876.26
Right of Way and Station Grounds .....	183,119.15	2,400,435.56	.....	2,583,554.71
Real Estate .....	.....	8,256.99	.....	8,256.99
Grading .....	346,591.98	633,382.23	214,992.77	1,194,966.98
Tunnels .....	27,629.67	.....	313.91	27,943.58
Bridges, Trestles and Culverts .....	254,738.34	276,460.05	599,636.98	1,130,835.37
Ties .....	164,366.43	305,992.25	7,082.87	477,441.55
Rails .....	211,635.84	485,722.81	311,654.92	1,009,013.57
Frogs and Switches..	5,038.99	53,660.14	21,178.59	79,877.72
Track Fastenings and Other Material .....	107,113.38	160,156.56	371,620.98	638,890.92
Ballast .....	24,744.28	88,766.18	119,692.85	233,203.31
Track Laying and Surfacing .....	74,838.92	355,478.12	130,218.81	560,535.85
Roadway Tools .....	.....	2,200.00	.....	2,200.00
Fencing Right of Way .....	5,276.41	12,702.35	190.54	18,169.30
Crossings and Signs..	463.40	29,730.59	83,469.77	113,663.76
Interlocking and Other Signal Apparatus .....	195.74	150,990.96	71,144.55	222,331.25
Telegraph and Telephone Lines .....	6,107.44	875.83	55,888.19	62,871.46
Station Buildings and Fixtures .....	13,404.58	97,522.17	457,504.05	568,430.80
General Office Building and Fixtures..	.....	.....	650,000.00	650,000.00
Shops, Engine Houses and Turn Tables..	2,820.22	11,683.44	57,044.57	71,548.23
Shop Machinery and Tools .....	.....	27,527.17	1,237.97	28,765.14
Water Stations .....	65,921.84	24,328.03	135,882.72	226,132.59
Fuel Stations .....	481.54	13,108.13	746.26	14,335.93
Storage Warehouses..	.....	3,717.99	.....	3,717.99
Dock and Wharf Property .....	16,227.76	.....	.....	16,227.76
Miscellaneous Structures .....	3,735.81	2,240.52	76,496.26	82,472.59
Transportation of Men and Material .....	107.52	.....	.....	107.52
Rent of Equipment..	42,320.94	.....	.....	42,320.94
Repairs of Equipment	8,601.22	.....	.....	8,601.22
Earnings and Operating expenses during construction...	1,544.83	.....	.....	1,544.83
<b>Total .....</b>	<b>\$1,602,494.06</b>	<b>\$5,182,048.79</b>	<b>\$3,412,295.27</b>	<b>\$10,196,838.12</b>
<b>II.—EQUIPMENT.</b>				
Steam Locomotives..	\$2,537,254.00	\$ 109,794.08	\$ 2,647,048.08	
Passenger Train Cars	15.61	41,811.77	41,827.38	
Freight Train Cars..	389,492.92	328,467.51	717,960.43	
Work Equipment .....	332,136.58	4,821.07	336,957.65	
Floating Equipment..	531.65	553.51	1,085.16	
<b>Total .....</b>	<b>\$3,259,430.76</b>	<b>\$ 485,447.94</b>	<b>\$ 3,744,878.70</b>	
<b>III.—GENERAL EXPENDITURES.</b>				
Law Expenses .....	\$ 1.00	.....	.....	\$ 1.00
Taxes .....	.....	.....	.....	648.50
Other Expenditures..	648.50	.....	.....	648.50
<b>Total .....</b>	<b>\$649.50</b>	.....	.....	<b>\$649.50</b>
<b>Grand Total .....</b>	<b>\$1,603,143.56</b>	<b>\$8,441,479.55</b>	<b>\$3,897,743.21</b>	<b>\$13,942,366.32</b>

MILEAGE STATISTICS.

ITEM.	1913. Miles.	1912. Miles.	Increase or Decrease. Miles.
<b>LOCOMOTIVE MILEAGE—</b>			
Revenue Service.			
Freight Locomotive Miles.....	19,130,297	18,375,751	Inc. 754,546
Passenger Locomotive Miles.....	17,862,403	17,892,325	Dec. 29,922
Mixed Locomotive Miles.....	844,265	851,499	Dec. 7,234
Special Locomotive Miles.....	17,310	19,580	Dec. 2,270
Switching Locomotive Miles.....	9,951,205	8,914,030	Inc. 1,037,175
<b>Total .....</b>	<b>47,805,480</b>	<b>46,053,185</b>	<b>Inc. 1,752,295</b>
Locomotive Mileage—Non-revenue Service .....			
	2,260,030	2,075,482	Inc. 184,548
<b>CAR MILEAGE—</b>			
Revenue Service.			
Freight Car Mileage:			
Loaded .....	460,405,258	421,665,175	Inc. 38,740,083
Empty .....	193,706,979	181,749,213	Inc. 11,957,766
Caboose .....	17,427,153	16,756,425	Inc. 670,728
<b>Total .....</b>	<b>671,539,390</b>	<b>620,170,813</b>	<b>Inc. 51,368,577</b>
Passenger Car Mileage:			
Passenger .....	46,273,265	45,718,181	Inc. 555,084
Sleeping, Parlor and Observation	26,388,011	26,862,496	Dec. 474,485
Other Passenger Train Cars.....	41,336,527	40,584,537	Inc. 751,990
<b>Total .....</b>	<b>113,997,803</b>	<b>113,165,214</b>	<b>Inc. 832,589</b>
Car Mileage in Special Service:			
Freight, Loaded .....	207,178	248,069	Dec. 40,891
Freight, Empty .....	320	44	Inc. 276
Caboose .....	16,219	18,700	Dec. 2,481
Passenger .....	60,598	74,265	Dec. 13,667
Sleeping, Parlor and Observation	.....	331	Dec. 331
Other Passenger Train Cars.....	86	187	Dec. 101
<b>Total .....</b>	<b>284,401</b>	<b>341,596</b>	<b>Dec. 57,195</b>

Total Car Mileage—Revenue Service .....	785,821,594	733,677,623	Inc. 52,143,971
Car Mileage—Non-revenue Service .....	10,136,338	9,075,026	Inc. 1,061,312
<b>TRAIN MILEAGE—</b>			
Revenue Service.			
Freight Train .....	17,331,661	16,688,629	Inc. 643,032
Passenger Train .....	17,461,373	17,422,976	Inc. 38,397
Mixed Train .....	838,983	846,642	Dec. 7,659
Special Train .....	16,378	19,067	Dec. 2,689
<b>Total Train Mileage—Revenue Service .....</b>	<b>35,648,395</b>	<b>34,977,314</b>	<b>Inc. 671,081</b>
Train Mileage—Non-revenue Service .....	1,331,388	1,279,407	Inc. 51,981

EQUIPMENT.

ITEMS.	Number on June 30, 1912.	Number Added During Year.	Number Retired During Year.	Number on June 30, 1913.	Average Tractive Power All Locomotives and Average Capacity All Freight Cars.
<b>LOCOMOTIVES—</b>					
Owned.					
Passenger .....	437	31	12	456	.....
Freight .....	873	102	53	922	.....
Switching .....	362	43	11	394	.....
<b>Total Locomotives .....</b>	<b>1,672</b>	<b>176</b>	<b>76</b>	<b>1,772</b>	<b>29,261 lbs.</b>
<b>CARS—Owned.</b>					
Passenger Service:					
First-class Cars.....	660	.....	1	659	.....
Combination Cars..	230	1	.....	231	.....
Dining Cars .....	37	.....	.....	37	.....
Baggage, Express and Postal Cars..	268	.....	1	267	.....
Parlor Cars .....	14	.....	.....	14	.....
Other Cars in Passenger Service...	45	.....	.....	45	.....
<b>Total .....</b>	<b>1,254</b>	<b>1</b>	<b>2</b>	<b>1,253</b>	.....
Freight Service:					
Box Cars .....	29,597	1,000	2,824	27,773	.....
Flat Cars .....	1,205	502	104	1,603	.....
Stock Cars .....	6,481	1,000	186	7,295	.....
Coal Cars .....	15,780	1,502	734	16,548	.....
Tank Cars .....	113	.....	.....	113	.....
Refrigerator Cars..	2,462	.....	144	2,318	.....
Other Cars in Freight Service .....	88	.....	3	85	.....
<b>Total .....</b>	<b>55,726</b>	<b>4,004</b>	<b>3,995</b>	<b>55,735</b>	<b>38.85 tons</b>
Company's Service:					
Officers' and Pay					
Cars .....	32	.....	.....	32	.....
Gravel Cars .....	978	.....	3	975	.....
Derrick Cars .....	40	1	.....	41	.....
Caboose Cars .....	680	2	.....	682	.....
Other Road Cars..	4,150	666	245	4,571	.....
<b>Total .....</b>	<b>5,880</b>	<b>669</b>	<b>248</b>	<b>6,301</b>	.....
<b>Total Cars Owned .....</b>	<b>62,860</b>	<b>4,674</b>	<b>4,245</b>	<b>63,289</b>	.....

NEW WORK.

Charges to Capital Account aggregating \$10,044,623.11 were made during the fiscal year for additions to the property.

On the extension from Thermopolis to Powder River, Wyoming, \$936,133.76 was expended during the year in the completion of bridges and track laying, for riprapping along the Badwater River, erecting station buildings and water plants, and in grading and tunnel work at Alkali Summit.

On the extension from Powder River to Orin Junction, Wyoming, \$554,489.26 has been expended this year for grading and bridge construction and in the purchase of right of way, etc. The above expenditure practically completed the grading and bridge construction of the line west of Casper, and it is expected next year to continue construction through to Orin Junction, thereby completing the entire line.

The amount expended on the Hudson-Greeley line, in Colorado, during the year was \$85,066.76 for right of way; no actual work on this line has yet been done.

Additional land was purchased for needed facilities in Chicago, Aurora, Denver and other points. New second track costing \$1,681,692.39 has been laid at various points and freight and passenger stations rebuilt where business and public convenience required these additions and improvements. There were placed in operation during the year 58.46 miles of additional second track and 74.54 miles of yard tracks and sidings.

A new yard has been built at Eola, Illinois, containing six tracks with a total length of about 4,000 feet, together with necessary water and coal stations.

The existing third track from Chicago to Belmont, Illinois, is being extended to Aurora, and the completion of automatic block signals covering this trackage has been authorized and the work is now under way, all of which improvements will provide facilities necessary for the more efficient and expeditious handling of business between these points.

For a distance of about nine miles north of Keokuk, Iowa, the tracks of the Company have been raised and rebuilt in order to place them above the flow line caused by the new power dam across the Mississippi River at that point.

Large expense is annually incurred in protecting the railroad property from encroachment of the Missouri River at Folsom, Iowa. Not only have the tracks of the line, Pacific Junction to Council Bluffs, been protected for some two miles with very heavy and expensive revetment work, but an additional mile is being put in to hold the bed of the river in its course and protect the east approach to the Company's bridge, over the Missouri River, near Plattsmouth.

Freight houses at Ottumwa, Des Moines and St. Joseph, which at the close of the last year were in course of construction, have been completed and put in service.

The new General Office building at Chicago was completed during the year and is now occupied.

Following is the report of the General Auditor, with statements prepared by him.

By order of the Board of Directors.

DARIUS MILLER, President.

GENERAL BALANCE SHEET.  
JUNE 30, 1913.

ASSETS.		LIABILITIES.	
<b>Property Investment—Road and Equipment:</b>		<b>Capital Stock:</b>	
Road .....	\$347,091,626.64	Common Stock .....	\$110,839,100.00
Equipment .....	66,139,343.78	<b>Mortgage, Bonded and Secured Debt:</b>	
General Expenditures .....	1,522,250.89	<b>Funded Debt—</b>	
Reserve for Accrued Depreciation—Credit .....	21,816,162.81	<b>Mortgage Bonds—</b>	
<b>Total .....</b>	<b>\$392,937,058.50</b>	Held by Company .....	\$11,445,000.00
		Not held by Company .....	186,712,800.00
		<b>Total .....</b>	<b>\$198,157,800.00</b>
<b>Securities:</b>		<b>Collateral Trust Bonds—</b>	
Securities of Proprietary, Affiliated and Controlled Companies, Pledged—		Held by Company .....	\$ 281,600.00
Stocks .....	\$ 19,363,139.38	Not held by Company .....	7,028,600.00
Securities Issued or Assumed, Pledged—		<b>Total .....</b>	<b>\$ 7,310,200.00</b>
Funded Debt .....	31,000.00	<b>Plain Bonds—</b>	
Securities of Proprietary, Affiliated and Controlled Companies, Unpledged—		Held by Company .....	\$ 163,000.00
Stocks .....	\$7,727,860.45	Not held by Company .....	3,504,000.00
Funded Debt .....	676,050.00	<b>Total .....</b>	<b>\$209,135,000.00</b>
<b>Total .....</b>	<b>\$ 27,798,049.83</b>	<b>Working Liabilities:</b>	
<b>Other Investments:</b>		Traffic and Car-service Balances due to other Companies ..	\$ 1,603,733.26
Advances to Proprietary, Affiliated and Controlled Companies for Construction, Equipment and Betterments ..	\$ 402,197.83	Audited Vouchers and Wages Unpaid .....	7,193,408.22
Miscellaneous Investments—		Miscellaneous Accounts Payable .....	324,368.24
Physical Property .....	\$1,430,056.41	Matured Interest and Dividends Unpaid .....	2,159,032.50
Securities Unpledged .....	1,489,396.89	Matured Mortgage, Bonded and Secured Debt Unpaid ..	145,000.00
<b>Total .....</b>	<b>\$ 3,321,651.13</b>	Other Working Liabilities .....	43,151.85
		<b>Total .....</b>	<b>\$ 11,468,694.07</b>
<b>Working Assets:</b>		<b>Accrued Liabilities not Due:</b>	
Cash .....	\$ 4,815,365.57	Unmatured Interest and Sinking Fund Payments .....	\$ 1,506,611.55
Securities Issued or Assumed, Held in Treasury—		Taxes Accrued .....	98,400.00
Funded Debt .....	11,858,600.00	<b>Total .....</b>	<b>\$ 1,605,011.55</b>
Marketable Securities—		<b>Deferred Credit Items:</b>	
Stocks .....	\$763,072.12	Operating Reserves .....	\$ 1,790,957.06
Funded Debt .....	62,500.00	Liability on Account of Provident Funds .....	496,538.89
Loans and Bills Receivable .....	3,255,493.31	Other Deferred Credit Items .....	440,485.04
Traffic and Car Service Balances due from other Companies ..	759,279.66	<b>Total .....</b>	<b>\$ 2,727,980.99</b>
Net Balance Due from Agents and Conductors .....	2,555,470.72	<b>Appropriated Surplus:</b>	
Miscellaneous Accounts Receivable .....	2,823,320.92	Additions to Property since June 30, 1907, through Income ..	\$ 21,421,216.24
Materials and Supplies .....	6,846,071.90	Reserves from Income or Surplus—	
Other Working Assets .....	132,312.82	Invested in Sinking Funds .....	32,942,793.87
<b>Total .....</b>	<b>\$ 33,871,487.02</b>	Not Specifically Invested .....	3,750,000.00
<b>Deferred Debit Items:</b>		<b>Total .....</b>	<b>\$ 58,114,010.11</b>
Advances—		<b>Profit and Loss:</b>	
Temporary Advances to Proprietary, Affiliated and Controlled Companies .....	\$ 170,998.17	Income Account .....	\$ 49,146,537.35
Working Funds .....	167,139.24	Profit and Loss .....	41,892,618.41
Other Advances .....	3,399,238.58	<b>Total .....</b>	<b>\$ 91,039,155.76</b>
Insurance Paid in Advance .....	145,201.10		
Cash and Securities in Sinking Funds .....	19,371,131.81		
Securities in Provident Funds .....	496,538.89		
Unextinguished Discount on Funded Debt .....	657,250.99		
Other Deferred Debit Items .....	2,593,207.22		
<b>Total .....</b>	<b>\$ 27,000,706.00</b>		
<b>Grand Total .....</b>	<b>\$484,928,952.48</b>	<b>Grand Total .....</b>	<b>\$484,928,952.48</b>

FUNDED DEBT OF THE CHICAGO, BURLINGTON & QUINCY RAILROAD COMPANY.

Designation of Bond or Obligation.	Term.		Total Par Value Authorized.	Total Par Value Outstanding.	Total Par Value Held by Company.		Total Par Value Not Held by Company.		Interest.	
	Date of Issue.	Date of Maturity.			In Treasury.	Pledged as Collateral.	In Sinking Funds.	In the Hands of the Public.	When Payable.	Amt. Accrued During the Year.
<b>MORTGAGE BONDS.</b>										
<i>C. B. &amp; Q. R. R.:</i>										
General Mortgage .....	1908	1958	\$68,634,000	\$68,634,000	\$10,387,000		\$58,247,000	4	M. & S.	\$2,580,586.63
Illinois Division .....	1899	1949	50,835,000	50,835,000	384,000		50,451,000	3½	J. & J.	1,779,225.00
Illinois Division .....	1899	1949	34,165,000	34,165,000	189,000		33,976,000	4	J. & J.	1,366,600.00
Iowa Division Mortgage Sinking Fund Bonds .....	1879	1919	3,000,000	2,197,000			2,197,000	5	A. & O.	110,812.45
Iowa Division Mortgage Sinking Fund Bonds .....	1879	1919	12,502,000	5,488,000	19,000		5,469,000	4	A. & O.	221,029.98
Nebraska Extension Mortgage Sinking Fund Bonds .....	1887	1927	29,441,000	22,238,000	316,000	\$31,000	21,891,000	4	M. & N.	899,686.65
<i>B. &amp; M. R. R. R. in Nebraska:</i>										
Consolidated Mortgage Sinking Fund Bonds .....	1878	1918	13,751,000	13,613,000	92,600		\$10,715,200	6	J. & J.	816,780.00
<i>Republican Valley R. R.:</i>										
Mortgage Sinking Fund Bonds .....	1879	1919	2,643,000	932,800	18,400		770,800	6	J. & J.	55,968.00
<i>Tarkio Valley R. R.:</i>										
Mortgage Bonds .....	1880	1920	430,000	28,000	3,000		25,000	7	J. & D.	2,088.35
<i>Nodaway Valley R. R.:</i>										
Mortgage Bonds .....	1880	1920	388,000	27,000	5,000		22,000	7	J. & D.	2,146.68
<b>COLLATERAL TRUST BONDS.</b>										
<i>C. B. &amp; Q. R. R.:</i>										
Sinking Fund Bonds (Denver Extension) .....	1881	1922	7,968,000	7,310,200	281,600		5,154,300	4	F. & A.	292,408.00
<b>PLAIN BONDS.</b>										
<i>C. B. &amp; Q. R. R.:</i>										
Sinking Fund Bonds .....	1881	1921	4,300,000	3,667,000	163,000		2,871,000	4	M. & S.	146,680.00
Plain Bonds .....	1883	1913	9,000,000							272,441.68
<b>Total .....</b>			<b>\$237,057,000</b>	<b>\$209,135,000</b>	<b>\$11,858,600</b>	<b>\$31,000</b>	<b>\$19,511,300</b>	<b>\$177,734,100</b>		<b>\$8,546,453.42</b>

**INCOME ACCOUNT.**

**OPERATING INCOME.**

**RAIL OPERATIONS—**

Operating Revenues:

Revenue from Transportation:

Freight .....	\$64,063,856.49
Passenger .....	21,895,690.73
Excess Baggage .....	310,373.26
Mail .....	2,329,351.41
Express .....	2,894,812.78
Milk .....	379,720.82
Other Passenger Train.....	9,766.23
Switching .....	1,327,074.27
Special Service Train.....	33,066.14
Miscellaneous Transportation	86,657.75
	<u>\$93,330,369.88</u>

Revenue from Operations other than Transportation:

Station and Train Privileges.\$	9,063.48
Parcel Room Receipts.....	12,073.75
Storage Freight .....	43,222.67
Storage Baggage .....	16,957.54
Car Service .....	319,759.64
Telegraph and Telephone Service .....	207,341.89
Rent of Buildings and other Property .....	101,938.39
Miscellaneous .....	199,019.23
	<u>909,376.59</u>
Joint Facilities, Dr.....	Dr. 3,511.87
Joint Facilities, Cr.....	138,250.91
	<u>\$94,374,485.51</u>

Total Operating Revenues. \$94,374,485.51

Operating Expenses:

Maintenance of Way and Structures .....	\$12,535,862.55
Maintenance of Equipment.	16,133,215.36
Traffic Expenses .....	1,586,802.81
Transportation Expenses....	29,997,717.32
General Expenses .....	2,589,292.99
	<u>\$62,842,891.03</u>

Net Operating Revenue... \$31,531,594.48

**OUTSIDE OPERATIONS:**

Revenues .....	\$ 909,697.13
Expenses .....	1,037,388.14
Net Deficit from Outside Operations .....	\$ 127,691.01
Total Net Revenue.....	<u>\$31,403,903.47</u>

**TAXES ACCRUED .....** 3,563,358.62

Operating Income .....

**OTHER INCOME.**

Rents Accrued from Lease of Roads .....

Other Rents—Credits:

Hire of Equipment—Balance..\$	65,740.87
Joint Facilities .....	532,691.13
Miscellaneous Rents .....	31,501.87
Dividends Received on Stocks Owned or Controlled .....	529,957.00
Interest Received on Funded Debt Owned or Controlled.....	489,508.14
Interest on Other Securities, Loans and Accounts .....	307,554.53
	<u>1,959,929.90</u>

Gross Corporate Income... \$29,800,474.75

**DEDUCTIONS FROM GROSS CORPORATE INCOME.**

Other Rents—Debits:

Joint Facilities .....	\$ 1,138,088.86
Miscellaneous Rents .....	19,983.01
Interest Accrued on Funded Debt Other Interest .....	8,546,453.42
Sinking Funds Chargeable to Income .....	305.52
Extinguishment of Discount on Securities .....	655,450.28
	<u>9,447.77</u>

Net Corporate Income.... \$19,430,745.89

**DISPOSITION OF NET CORPORATE INCOME.**

Dividends declared on Stock:

2 per cent, payable Sept. 25, 1912 .....	\$ 2,216,782.00
2 per cent, payable Dec. 26, 1912 .....	2,216,782.00
2 per cent, payable March 25, 1913 .....	2,216,782.00
2 per cent, payable June 25, 1913 .....	2,216,782.00
	<u>\$ 8,867,128.00</u>

Appropriations for Betterments: 7,647,743.21 \$16,514,871.21

Surplus for the year.... \$ 2,915,874.69

**SINKING FUND ASSETS ON JUNE 30, 1913.**

**SECURITIES IN FUNDS.**

Name of Fund and Security.	Cost or Book Value.		Cash in Fund.	Total.
	Par Value.			
C. B. & Q. R. R. 4 and 5 per cent Bonds of 1919 (Iowa Division) .....			\$ 1,439.27	\$ 1,439.27
C. B. & Q. R. R. 4 per cent Bonds of 1921..\$ 2,871,000	\$ 2,871,000	\$ 2,750,548.37	59,208.04	2,809,756.41
C. B. & Q. R. R. 4 per cent Bonds of 1922 (Denver Extension) .....	5,154,300	5,030,130.74	40,955.57	5,071,086.31
B. & M. R. R. R. in Nebraska Consolidated Mortgage 6 per cent Bonds of 1918.....	10,715,200	10,715,200.00	1,850.69	10,717,050.69
Republican Valley R. R. 6 per cent Bonds of 1919 .....	770,800	770,800.00	999.13	771,799.13
Total .....	\$19,511,300	\$19,266,679.11	\$104,452.70	\$19,371,131.81

**FREIGHT TRAFFIC MOVEMENT—ENTIRE LINE.**

**COMPANY'S MATERIAL EXCLUDED.**

COMMODITIES.	Originating on this Road. Tons.	Received from Connections. Tons.	Total Freight Tonnage.	
			Tons.	Per Cent.
<b>Products of Agriculture—</b>				
Grain .....	3,462,079	457,108	3,919,187	11.71
Flour .....	623,610	126,422	750,032	2.24
Other Mill Products.....	258,937	53,590	312,527	.93
Hay .....	217,428	76,482	293,910	.88
Tobacco .....	3,982	1,293	5,275	.02
Cotton .....	1,384	15,747	17,131	.05
Fruits and Vegetables.....	469,084	717,058	1,186,142	3.55
Other Products .....	159,407	84,012	243,419	.73
Total .....	5,195,911	1,531,712	6,727,623	20.11

<b>Products of Animals—</b>				
Live Stock .....	1,584,311	207,267	1,791,578	5.35
Dressed Meats .....	189,151	7,274	196,425	.59
Other Packing House Products..	122,573	6,784	129,357	.39
Poultry, Game and Fish.....	58,431	31,818	90,249	.27
Wool .....	5,782	9,578	15,360	.05
Hides and Leather .....	14,553	2,238	16,791	.05
Other Products .....	59,289	18,781	78,070	.23
Total .....	2,034,090	283,740	2,317,830	6.93
<b>Products of Mines—</b>				
Anthracite Coal .....	32,233	165,685	197,918	.59
Bituminous Coal .....	7,764,236	2,584,402	10,348,638	30.93
Coke .....	23,878	164,468	188,346	.56
Ores .....	85,318	363,266	448,584	1.34
Stone, Sand, etc. ....	1,813,972	294,793	2,108,765	6.30
Other Products .....	107,059	265,175	372,234	1.12
Total .....	9,826,696	3,837,789	13,664,485	40.84
<b>Products of Forests—</b>				
Lumber .....	326,492	1,660,886	1,987,378	5.94
Other Products .....	129,034	203,776	332,810	.99
Total .....	455,526	1,864,662	2,320,188	6.93
<b>Manufactures—</b>				
Petroleum and other Oils.....	147,436	297,123	444,559	1.33
Sugar .....	110,667	122,316	232,983	.70
Naval Stores .....	10,492	3,230	13,722	.04
Iron, Pig and Bloom.....	26,693	166,217	192,910	.59
Iron and Steel Rails.....	31,934	180,304	212,238	.63
Other Castings and Machinery..	198,568	280,844	479,412	1.43
Bar and Sheet Metal.....	82,864	234,786	317,650	.95
Cement, Brick and Lime.....	1,196,221	548,250	1,744,471	5.21
Agricultural Implements .....	205,565	84,893	290,458	.87
Wagons, Carriages, Tools, etc....	41,218	54,550	95,768	.28
Wines, Liquors and Beers.....	149,875	48,537	198,412	.59
Household Goods, etc. ....	157,993	76,685	234,678	.70
Other Manufactures .....	574,730	458,105	1,032,835	3.09
Total .....	2,934,256	2,555,840	5,490,096	16.41
Merchandise .....	1,394,641	677,634	2,072,275	6.19
Miscellaneous .....	689,896	176,086	865,982	2.59
Total Tonnage .....	22,531,016	10,927,463	33,458,479	100.00

# Railway Age Gazette

PUBLISHED EVERY FRIDAY AND DAILY EIGHT TIMES IN JUNE, BY THE  
SIMMONS-BOARDMAN PUBLISHING COMPANY,  
WOOLWORTH BUILDING, NEW YORK.

CHICAGO: Transportation Bldg. CLEVELAND: Citizens' Bldg.  
LONDON: Queen Anne's Chambers, Westminster.

E. A. SIMMONS, *President.*

L. B. SHERMAN, *Vice-President.* HENRY LEE, *Sec'y & Treas.*  
The address of the company is the address of the officers.

EDITORS.

SAMUEL O. DUNN, *Editor.*

ROY V. WRIGHT, <i>Managing Editor.</i>	H. H. SIMMONS	E. S. FAUST
W. E. HOOPER	H. F. LANE	F. W. KRAEGER
B. B. ADAMS	E. A. AVERILL	A. D. CLOUD
E. T. HOWSON	R. E. THAYER	GEORGE L. FOWLER
	A. C. LOUDON	

Subscriptions, including 52 regular weekly issues and special daily editions published from time to time in New York, or in places other than New York, payable in advance and postage free:

United States and Mexico.....	\$5.00
Canada.....	6.00
Foreign Countries (excepting daily editions).....	8.00
Single Copies.....	15 cents each

Engineering and Maintenance of Way Edition and four Maintenance of Way Convention Daily issues, North America, \$1.00; foreign, \$2.00.

Entered at the Post Office at New York, N. Y., as mail matter of the second class.

WE GUARANTEE, that of this issue 8,300 copies were printed; that of these 8,300 copies, 6,612 were mailed to regular paid subscribers and 850 were provided for counter and news companies' sales; that the total copies printed this year to date were 396,509—an average of 8,619 copies a week.

VOLUME 55. NOVEMBER 14, 1913. NUMBER 20.

## CONTENTS

EDITORIAL:

Editorial Notes.....	897
Locomotive Runners Who Know Their Business.....	898
Overhead Inspection of Box Cars.....	898
Increases in Wages and in the Cost of Living.....	899
Movement of Wages, Prices and Railway Rates.....	899
New Books.....	900

MISCELLANEOUS:

Rules for Keeping a Lookout on a Busy Road; by Edward F. McKenzie.....	901
The Wrought Steel Wheel; by D. F. Crawford.....	902
*Summit-Hallstead Cut-Off of D. L. & W.....	903
Eastern Trainmen's Wages Settled.....	909
*W. C. Nixon and the Frisco.....	914
Overloading Freight Locomotives Not Economical; by J. S. Sheafe.....	915
*Gas-Electric Locomotive.....	916
Mr. Mellen Speaks Out.....	918
Movement of Prices and Railway Rates; by M. Clement Colson.....	919
*Constant Voltage Axle Lighting System.....	923
Refunding Overcharges in Oklahoma.....	924
Foreign Railway Notes.....	908, 913, 914, 917, 924

GENERAL NEWS SECTION..... 925

\*Illustrated.

THE award of the arbitrators in the matter of the wages of the conductors and brakemen on the "Eastern" railroads has the merit of being easily understood. It is a very well-written document. The more important reasons for the award are clearly stated, and the verdict of the public will not have to be, as so commonly in the past, "they just split the difference." An average increase of 7 per cent. has been granted, almost wholly because the cost of living has increased. Messrs. Atterbury and Smith in their dissenting opinion declared that the highest figure sustained by the evidence as to cost of living is 5.36; and on this ground they protest. Messrs. Low and Finley, the neutral arbitrators, evidently took into consideration factors concerning cost of living not definitely shown in the evidence, yet of

appreciable weight. The company arbitrators protest that the men were already liberally paid; but both sides agreed as to the propriety of not considering conditions prior to 1910, the year of the last previous award; and, as everybody knows, the present big pay dates from that year. In other words, for any injustice now imposed on them the companies must put the chief blame, not on the present arbitrators, but on what was done in 1910. On the question of standardization of the rates of pay throughout the whole country, the report contains some fine-sounding words about uniformity in the government service, and the logical relation between government service and railway service; but the decision practically admits Messrs. Atterbury and Smith's view that the idea is chimerical. These dissenters show a possible weakness in Messrs. Low and Finley's opinion that standardization as between the East and the South has now been attained. The claims of the men concerning increased risk and their greater responsibility; and as to their share in alleged increased profits, are shown to be exceedingly weak, even groundless. The demands for time and one half for (a) double-head trains and (b) for overtime, were rejected. The first of these is utterly unreasonable and the second nearly as bad. This whole subject of overtime demands further and full discussion. The neutral arbitrators did not have time to master it. They did, however, declare in plain language that in train service punitive overtime is wrong in principle. On the whole it may be said that the neutral arbitrators, who decided everything, have given the employees the 7 per cent., and nothing more. The employees' other claims are all shown to be unreasonable. The roads' claim that the pay is now good is likewise rejected quite summarily; "not proved."

THE season for the beginning of Christmas shopping is now open. It is, therefore, once more an opportune time to remind our readers in the railway and railway supply businesses that nowadays they live, work and have their being in the spotlight of publicity. This being true, it behooves them to avoid both evil and the appearance of evil. Sometimes there is real evil in the giving of Christmas presents when the donor is a man who is seeking to get contracts and the recipient is the man from whom he is trying to get them. Sometimes there is no evil in it. Seldom, however, do presents of substantial value pass between a representative of a supply concern and an officer, whether high or low, of a railway without the incident presenting at least the appearance of evil. Such gift-giving and gift-receiving, if not open to just censure, is clearly open to a construction which is adapted to do both the railways and the supply concerns harm. Last year and the year before at about this time the *Railway Age Gazette* warned against the dangers incidental to the extensive practice of present-giving which has grown up in the railway and railway supply businesses. It is believed that our comments on the subject and those which others have made, have done some good. They have not, however, had the effect of abolishing the practice. What is still worse, all the discussions of, and the scandals connected with various forms of grafting have not been sufficient to eliminate it from the railway business. There are numerous forms of stupidity. The most bone-headed form of it, however, is the stupidity of dishonesty. No man is so hard to convince that he should desist from doing things that he is doing as the man who is making a dishonest profit from doing those things. His stupidity almost always leads him to believe that he, at least, is shrewd enough to prevent his conduct from being detected and exposed. The experience of others who have been detected, exposed and disgraced for doing just as he is doing usually is lost upon him. It would seem, however, that the many, many developments which have occurred in the railway business within the last decade, and especially within the last half decade—should have taught every man who is connected with that business or who has business relations with it, that the time has come when it behooves him to put his house in order so that

when the muckrakers for the magazines, or the inspectors of the Interstate Commerce Commission, or the lawyers for the Interstate Commerce Commission, swoop down on him they will not find anything which he would not like to have them find.

#### LOCOMOTIVE RUNNERS WHO KNOW THEIR BUSINESS.

THE prize essay on keeping a lookout on the locomotive, one of a large bunch of excellent papers on this subject received in response to the offer which was published in our issue of August 15, is by Edward F. McKenzie, and is printed on another page. It comes from one of the prize railroad divisions of the country, the Pittsburgh division of the Pennsylvania.

Considering the elaborate block signal equipment of the Pittsburgh division there may be readers to whom it will occur that Mr. McKenzie's problem may in some respects be less difficult than that of an engineman on a road of thinner traffic and not so favorably situated; but these are reminded that there will be other excellent papers, in later issues, from runners in other parts of the country.

A reading of all these papers gives one a high opinion of American enginemen, and it is a matter of much regret that only a part of the very good material that has been received can be used. Those writers who have sent papers full of excellent ideas, but who have not taken the prize, are reminded that the competition was very close. The prize was for a paper dealing with the single question of the lookout; but we shall print a number of papers which deal with the engineman's duties in a more general way.

To readers not familiar with train-running it is perhaps proper to offer the reminder that Mr. McKenzie's statement that there are 1,200 signals between Pittsburgh and Altoona does not mean that a hundred miles of line is divided into sections a twelfth of a mile in length. With such short sections, the engineman of a fast train would have to be watching for a new signal every five seconds, continuously, for an hour and a half or longer. What Mr. McKenzie means is that there are 1,200 signals, every one of which the engineman must know the meaning of. The shortest block sections are 4,200 ft. long. For a given trip, the duty of the engineman of a fast train, as regards the signals, is to watch for one signal at the approach to each block section, and then, next, one immediately at the entrance to that section. And this one signal that calls for his attention is the one easiest to pick out; it is the top signal (if there be more than one on a single post) on the post for the track on which he is running, and the post is either exactly above that track (on a bridge) or immediately to the right. And every approach signal is set far enough back from the entrance to the block section to allow space in which to stop the train after the engine passes the signal (in case a stop is necessary), so that there is no trouble because of fogs or snow storms which might prevent the runner from seeing the signal until he got close to it; and the less familiar signals do not have to be dealt with at high speeds.

This explanation is made here, not to impair the force of Mr. McKenzie's statements, but to make sure that they shall be looked at in the right way. The Pittsburgh division is well signaled, but that does not detract from the credit due the enginemen. No runner who has given satisfactory service on that division for five years can be other than a very competent engineer.

Next week, or in the near future, a number of other papers will be printed. These will give the reader interesting pictures of the locomotive engineer's life in all parts of the country. The writers have not only described their work in a very entertaining way, but all of them have served in the cab for many years, and they have thrown in enough of their experiences to give their narratives a decidedly "human interest."

#### OVERHEAD INSPECTION OF BOX CARS.

THE need of standard practice in the overhead inspection of box cars has become more of a necessity than ever since the Freight Claim Association agreed upon the apportionment between railways of claims for loss and damage to freight caused by defective cars not properly inspected. Under the new rule that went into effect the first of last September the loading carrier is to be held liable for the condition of the car in which the freight is loaded, and will be charged for such damage as may occur on account of defects not repaired before loading. With definite rules for all roads to follow there will be less chance for misunderstandings, and should be more uniform and better service to shippers, the latter being of paramount importance.

The originating road can no longer offer cars to shippers that are unsatisfactory for their merchandise without being held for the loss or damage that may occur to that shipment on account of the original defects of the car. It is therefore of no advantage to offer such a car for the shipper to accept or reject as he desires, inasmuch as the shipper may be compelled to use the defective car on account of the stress of business. It is erroneous to assume that a shipper would load such a car from "malice aforethought," as it is to his interest to have his products reach his customer in the best possible condition. In order to obtain the best possible results the inspection should be carried back from the point of delivery to the shops, where a rigid inspection should be made for leaky roofs, projecting bolts, protruding nails, leaky doors, etc., even though these items were not scheduled for repairs. By doing this and making the necessary additional repairs much time and money will be saved, and a greater number of suitable cars will be available for special freight.

As regards the loading; while it is unquestionably the duty of the shipper to see that a car is loaded properly, it is also the duty of the carrier to see, when the load is transferred from one car to another during transit, that the freight is loaded in the same substantial way, and as well protected from possible injury as it was in the original car. In order to do this properly a certain amount of instruction must be given the freight handlers regarding the handling of the various commodities, and where contract labor is employed a system should be adopted for holding the contractors to account for the damage for which they are responsible. Adequate equipment should be installed at the places where trans-shipments are made, so that there can be no excuse for employing improper methods. In cases where cars become damaged in transit it is the duty of the carrier to make the necessary repairs immediately in order to protect the freight. Cars carrying different classes of freight require different degrees of care in inspection, and inspectors should be so instructed that the special requirements of each commodity will be met.

With fair and consistent co-operation between the carriers and the shippers, and between the carriers themselves, a great good can be accomplished. This co-operation, to obtain the best results, must, however, extend down to the humblest car repairer. With the slogan, "protect the freight," as well as the slogan, "keep the cars moving," constantly kept in mind by the railway men, from the president down to the switchman in the yards, and the laborer in the shops, a great benefit may be obtained, and the real purpose of a railway more fully accomplished. That the railways are working along the right lines is evident from the interest the various organizations are taking in car inspection. The Master Car Builders' Association presented a complete report on the subject of overhead inspection at its last meeting, and is working with the American Railway Association toward a standardization of the methods of inspection for the different commodities. It has also modified the rules of interchange so as to expedite the making of proper repairs to loaded cars. While this is a move in the right direc-

tion, to secure proper inspection it will always require constant efforts of railway employees which can be secured only by constant supervision by their superiors.

#### INCREASES IN WAGES AND IN THE COST OF LIVING.

THE wage advance granted by the board of arbitration to the conductors and trainmen on the eastern railways was based almost entirely on a corresponding advance believed to have taken place in the cost of living. That there had been an increase in the cost of living seemed clear. If an increase in the cost of living is a sufficient reason for raising the wages of railway employees, it is a sufficient reason for raising the wages of other working men. Wages cannot be increased in any industry unless there be an equivalent increase in the efficiency of labor, without affecting the cost of operation and production in that industry, for in every industry the wages of labor are the principal factor in operating expenses, and in most of them, as, for example, in the transportation industry, wages are very much the most important factor. If the cost of operation and production in an industry is increased to any considerable extent, then the rates or prices charged for the services rendered or the goods sold by that industry must also be increased. But an increase in the charges for services and the prices of goods is, of course, an increase in the cost of living, and consequently justifies another increase in wages, which will cause another increase in the cost of living, which will justify another increase in wages; and so on *ad infinitum*.

Thus far the enormous increases in wages that have been made in the railway industry have not caused advances in rates, but the point has been reached where they must cause such advances if the railways are to remain solvent and the further expansion of transportation facilities is to be secured. Of course, when rates go up prices will be affected and the cost of living will advance more or less. In other words, we seem to have been caught in a vicious circle, and to be unable to find any place to break it. And thus far those who have tried to deal with the situation also have run around in circles. A dog chasing its tail presents an example of wisdom about equal to that presented thus far by economists, public men and industrial leaders in grappling with the related questions of increasing wages, increasing costs of production and increasing cost of living.

The conditions referred to may be due, as some economists contend, partly to a depreciation in the value of money caused by an excessive production of gold. To the extent that this is true, the remedy, of course, is to stop the depreciation of the dollar, if there is a way to do it. But all that is needed to demonstrate that this is not the only cause is the evidence of our own eyes. First, this evidence shows that the demands for the products of the land are growing faster in proportion than the supply of them. That this shall tend to increase the cost of living is inevitable. Second, the evidence certainly indicates that the average efficiency of labor is decreasing, and as the cost of labor is the chief factor in the cost of production, the inevitable result of this must be to increase the cost of production and thereby the cost of living.

Already great efforts are being made to reduce the disproportion between the growth in the demand for, and the supply of, the products of the land. There is need for educating the working man as to the conditions which he is producing as well as the farmer regarding the conditions with which he is confronted. There is a large class of working people whose members believe that they actually help to increase their wages by limiting the amount of work which they do. Now, increases in wages accompanied by increases in the efficiency of labor have no tendency to increase the cost of production and the cost of living; but increases in wages unaccompanied by increases in the efficiency of labor, or accompanied by positive decreases in it, have a very potent tendency to increase the cost of living; and an increase in the cost of living is equivalent to a reduction in wages. In other words, the labor union policy of promoting the inefficiency of

labor is simply a policy of cutting off the workman's nose to spite the capitalist's face.

Meantime, the railways are beginning to suffer worse than anybody else from the increase in the cost of living. They are required to raise wages of their unionized men without getting any return in better work done, and at the same time they are confronted by demands from the public for an improved grade of transportation. When the railways present the railway dilemma to boards of arbitration these boards say, as the one that just settled the trainmen's controversy said, that "the Interstate Commerce Commission, and not this arbitration board, has the duty of determining whether the railroads can earn, in addition to their other charges, without an increase in rates, the rates of pay that this board believes at the present time to be due to the conductors and trainmen."

The railways appealed once to the Interstate Commerce Commission for higher rates before the advances in wages of recent years were made. They are now appealing to it again. Let us hope that the commission will give as much consideration to the increase in the railways' cost of living as the arbitration boards do to the increase in the railway employees' cost of living.

#### MOVEMENT OF WAGES, PRICES AND RAILWAY RATES.

WE publish elsewhere in this issue an article entitled "The Movement of Prices and Railway Rates" from the pen of Clement Colson, the distinguished French authority on transportation matters. M. Colson shows that within recent years there have been large increases in the wages of labor and the prices of commodities throughout the world. He shows also that in all parts of the world these things have begun strongly to influence the tendency of railway rates. The trend of the charges for rail transportation was downward so long that it came to be regarded as a law of economics, and almost a law of nature, that they should go on diminishing indefinitely. But, as has heretofore been pointed out in these columns, and as M. Colson shows with fullness of illustration, the tendency of rates to decline has been arrested, and the trend has become upward.

M. Colson refers to advances, or the equivalents of advances, which recently have been made in England, Prussia, Wurtemberg, Italy, Switzerland, Belgium, Denmark, Russia, Austria and Hungary. This list refers chiefly to changes in rates made by railways owned by governments. It has been found necessary during the last year to make advances also on other state railways as far removed from Europe as the New South Wales lines and the Intercolonial in Canada. The Minister of Railways of New Zealand in his railway statement for 1913 calls attention to the fact that, although the gross earnings of these lines showed a substantial increase over the preceding year, the operating expenses increased still more, and in consequence, the percentage of working expenses increased from 67.07 to 68.13. The causes to which these increases in railway expenses in New England are attributed are the same as those to which similar results are attributed throughout the world. While the report suggests no increases in rates, it affords evidence that the present rates are insufficient to cover interest on the railway investment.

It would appear, in fact, that the United States, Canada and France are about the only leading countries in which there have been no net advances in rates in recent years. The English railways, although privately owned, succeeded in wringing an advance from the government when it was plainly necessary to grant it in order to prevent a great railway strike. In any other circumstances it is doubtful if the English roads would have secured an advance, and probably the chief reason why it has been found difficult to secure advances in France and the United States is that most of the railways of France, and all of those of the United States, are owned by private companies. Experience is making it increasingly apparent that it is easier for state railways to raise their rates than for private railways.

M. Colson attributes the general increases in the prices of commodities, and also the increases in railway expenses, throughout the world largely to the declining efficiency of labor. The evidence strongly indicates that whether in Europe, or Australia, or North America, the efficiency of labor is decreasing. The complaints of it which come from these widely-separated parts of the world are expressed in almost identical language. M. Colson refers to it in precisely the same way that officers of the English railways do; and the officers of English railways refer to it in precisely the same way that the officers of the railways of the United States do. It is obvious that a decrease in the efficiency of labor, unaccompanied by any reduction in the wages of labor, must tend to increase the cost of production, and therefore, the prices of commodities; and this result will be much more patent and extreme if a decline in the efficiency of labor is actually accompanied by an increase in its wages.

If the decline in the efficiency of labor is considerable, this, together with increases in wages, may more than nullify the tendency of the introduction of labor-saving machinery to reduce the cost of production. That a process of this kind has been going on is a growing belief among economists. M. Colson in his article shows that in France wages have increased greatly within recent years, but that the cost of living has increased almost as much in proportion, and in consequence, the purchasing power of wages has advanced but slightly. So, Professor J. Laurence Laughlin points out in an article, entitled "Monopoly of Labor," in the *Atlantic Monthly* for November, that "in the principal manufacturing and mechanical industries, leaving out salaried employees, in the 10 years from 1897-1907 (according to the index number of the Bureau of Labor), wages had risen from 99.2 to 122.4 or 23 per cent., while prices for food had increased from 96.3 to 120.6 or 25.5 per cent. That is, the purchasing power of wages fell 2.5 per cent. during that period of unusual expansion of business." The increase in the cost of living is given in wage arbitrations as the main reason why wages should constantly be increased. If it be true that the increase in the cost of living is largely due to advances in the wages and reductions of the efficiency of labor, then it is evident that to continue to increase wages because the cost of living is increasing is to move in a vicious circle. After all, it is obvious that, in the long run, the only way to increase the real wages of labor is to increase the productiveness of labor, because the real wages of labor are the amount of consumable goods which its money wages will command, and the only way to increase the amount of consumable goods that any given amount of money wages will command is to reduce the cost of production.

However, whatever may be the causes of the increases in wages and prices in general, it is evident that such increases cannot go on forever without affecting the amount of rates which railways must receive for their services, and equally obvious is it that it cannot be expected that railway rates in the United States shall remain stationary or trend downward while they are advancing in almost all other parts of the world. The play of given economic forces must produce in the long run the same results in this country as in other countries. M. Colson's article will well repay reading by those who imagine that there is anything singular about the railway conditions existing in this country, or about the steps which the railways are taking for the purpose of dealing with these conditions.

#### NEW BOOKS.

*Safety Through the Block Signal System.* By Hon. John J. Esch. Washington: Government Printing Office. Pamphlet, 11 pages.

Representative Esch, of Wisconsin, is the author of the most rational of the several bills which have been presented in Congress to make compulsory the use of the block system on passenger lines generally; and this pamphlet consists of a reprint, from the *Congressional Record*, of the speech made by him in the House on September 6 last, in the discussion on the clause

in the urgent deficiency bill appropriating \$25,000 for the use of the Interstate Commerce Commission in the investigation of matters concerning safety on railroads. Mr. Esch's speech includes all of the principal arguments in favor of the use of the space-interval system in train management. Presumably, the pamphlet is sent free by the clerk of the House Committee on Interstate and Foreign Commerce.

*Standard Specifications for Steel and Steel Products.* Bound in cloth. 6½ in. x 9½ in. Published by the American Society for Testing Materials, Edgar Marburg, Philadelphia, Pa., secretary. Price \$3, including translations into German, French and Spanish. Paper bound, in one language, \$1.

This book contains twenty standard specifications for steel products, as prepared by Committee A-1 of the American Society for Testing Materials and published in the year book for 1912. These specifications are printed in English, German, French and Spanish for the use of any of the members who desire to make their specifications known in foreign countries. It is hoped that other leading countries will follow this method. The following is a list of the specifications included: Bessemer steel rails; open-hearth steel rails; open hearth girder and high tee rails; steel splice bars; structural steel for bridges; structural nickel steel; structural steel for buildings; structural steel for ships; boiler and firebox steel; boiler rivet steel; steel axles; heat-treated carbon steel axles, shafts and similar objects; forged and rolled, forged, or rolled solid carbon-steel wheels for engine truck, tender and passenger service; the same for freight service; steel tires; steel forgings; steel castings; annealed steel forgings; steel shapes, universal mill plates, and bars; and lap-welded and seamless steel boiler tubes and safe ends, 2½ in. and under.

*Statistics of Railways.* Twenty-fourth Annual Report, 1911. Interstate Commerce Commission, Washington, D. C.

This report, more than two years behind time, has just come out; and the commission announces that on account of extraordinary demands on its appropriation for printing a charge of \$1 will be made for copies of the report. Orders should be sent to the Superintendent of Documents, Government Printing Office, Washington, D. C. Copies of the text of the report, 66 pages, may be had for 10 cents each. Remittances should be sent with orders, and for books mailed to foreign countries, except Canada, Cuba and Mexico, remittances must cover the cost of postage.

The 1911 report differs in numerous particulars from the preceding reports in the series. A notable difference exists in the substitution of three districts, substantially identical with the three great freight classification territories, for the ten territorial "groups" into which the United States was divided for statistical purposes in 1890, and also in the classification of railway companies with reference to their annual operating revenues. The report is of "Census" measure, giving a page 9 x 11½ in., which is much larger than that of prior reports.

The general character of the text of the report is similar to that of the 1910 report, but the statistical tables in the body of the report following the text differ materially in form and in detail from the tables in previous reports.

Section A, Part I, contains abstracts of reports rendered by steam railway companies of Class I; companies having annual operating revenues above \$1,000,000. These contain not only the usual income and profit and loss account and revenues and expenses, but many details of investments, of marketable securities; of redemption funds, insurance and provident funds, etc. Part II contains similar abstracts of companies of Class II; companies having annual operating revenues from \$100,000 to \$1,000,000. Part III is for companies of Class III those having annual operating revenues below \$100,000. In this the statistics are less elaborate.

Section B contains abstracts of reports rendered by lesser steam railway companies. An appendix contains statistics of switching and terminal companies.

# RULES FOR KEEPING A LOOKOUT ON A BUSY ROAD.

An Outline of the Cure for "Mental Straggling." Prize Article; Adjudged the Best One of Forty-six Received.

By EDWARD F. MCKENZIE.

On the Pittsburgh division of the Pennsylvania Railroad after running a freight engine an average of ten years you receive a letter from the road foreman, nominating you for the position of passenger engineman if you qualify.

To qualify you must pass a perfect examination on eyesight and hearing, and make at least 85 per cent. on machinery, air brake, rules, time tables, special and block signal rules and signals.

On this division we have about 1,200 miles of track on main line and branches on which a man entering passenger service must qualify by an examination before our signal instructor before being permitted to run, as extra men go all over the division on anything their turn may call for.

We have automatic, semi-automatic, interlocking, manual, manual controlled and unattended (telephone) block signals; and it is absolutely necessary to know where each signal is, and what kind it is as well as what it indicates; and to be thoroughly familiar with the block signal rules that apply to each different kind of signal.

I have been an engineman eighteen years, seven of which has been on passenger, and have been on a regular run ten months. I will give you my way of working the extra passenger list, which is the most difficult position to fill successfully on the division.

I abstain absolutely from all intoxicating liquors.

I never come to work except in the best of health; take all the rest I can get; live happily with my family and leave my family affairs absolutely at home and think only of the work ahead when on duty.

I obey the rules of the company absolutely, in regard to (a) looking over the bulletin board, (b) comparing time with standard clock, (c) signing for general orders and registering, and (d) the rigid inspection of engine before going out.

I am very particular in testing air brake, signal whistle, sand pipes and injectors. Nothing takes your attention away from the track so much as a bad working injector, or an engine slipping because of defective sand pipes.

I tell all my stories and do all my talking to the fireman before leaving, and allow no conversation on the engine while running except the calling of signals and the answering of them, unless the fireman notices something wrong with his side of engine; then I instruct him to step up alongside of me and talk direct, while I look straight ahead; and not yell across boiler and take my attention away from track.

As we run all trains, local or through, as our turn calls for, it is necessary to study the time table before going out, pinning the leaves at your particular schedule and also the schedule of opposing trains,\* so that you can see your figures at a glance in each direction and not run by a [standing passenger] train at an unprotected station.

We are now ready to leave. On the main line between Pittsburgh and Altoona we have about 1,800 signals, each way, in a distance of 114 miles; and have about 259 signals in the Pittsburgh station limits, 0.6 mile.

The greatest distance between signal bridges is 4,200 ft.; and at interlocking plants or where traffic closes up we have three in that distance; so it will be seen that we have to keep a good lookout, under normal conditions, as well as on track, for flagman in case of emergency.

We call all signals as well as the numbers of opposing trains, so we know what trains have been represented.

When diverted to freight tracks we have, in addition, at six places going in one direction and seven going the other, to receive a hand signal from switchman holding green flag by day and green lamp by night. The fouling of any of these switches without first receiving this signal is the same as running by a stop signal, and is a violation of the rules.

At bad places, such as high hills and public road crossings, where watchmen are stationed permanently, I keep a very close watch for them.

I recently saved an automobile and its occupants by using brake hard when I saw the crossing watchman give the automobile a signal to cross over when he had overlooked my train. As I was making a station stop I had no trouble in reducing speed sufficient to allow him to clear. If I had not noticed the watchman I should have struck the automobile.

I also had an example when I first went into passenger service of allowing the mind to stray: While planning a pleasure trip for myself and family I had to make a rough stop to keep from running by a regular station stop; that cured me, and I allow no mental straggling since.

But the discipline of the mind necessary to keep up a vigilant habit is, of course, a continuing matter. We all begin some discipline of the mind in childhood. In railroading a man must give attention to this as soon as he goes to firing. He should profit by other men's failures and resolve never to allow himself to do likewise.

While I was firing, my engineman ran past a signal while taking off his overclothes. I resolved never to take mine off until I arrived at the ash pit, and I have lived up to this resolve. Some roads in recent years have posted notices on this subject, forbidding this practice and also forbidding washing up approaching the terminal.

On parts of our division we receive two caution or distant automatic signal indications, the first one being two blocks or about 8,000 ft. in the rear of the stop signal, while the other is one block, or about 4,000 ft. back. But the rule nevertheless requires trains to approach the second distant prepared to stop; it may be set at stop because of an accident. The failure to observe this rule to the letter caused one of our best passenger enginemen to side-wipe a wreck that had occurred just ahead of him, and both he and his fireman lost their lives.

The sub-conscious mind (or instinct) should be trained to act promptly. While running about 35 miles an hour with a heavy passenger train on a dark night, I ran through a box car that had been derailed on the adjoining track and had fallen in my path. This was on the Horse Shoe curve. From the time the pilot struck, until the cab of the engine struck was about  $\frac{1}{2}$  second; in that time I shut the throttle, applied air brake, opened sand valve, reversed engine, jumped down behind boiler and whistled brakes for the second engine. We stopped in a little over 130 ft., as we were going up hill. As I had no warning I could not have thought and acted so quickly; neither could the other engineman have done his part, if it were not a part of a runner's nature to be eternally on the lookout for trouble—trouble which we don't want to find.

One of our enginemen who saw a caution signal in the clear position and could not see the top or home signal because of smoke, ran by. It proved to be a surprise test, the signal being capped. He was severely disciplined; and the rest of us were in that way warned, by the company, that a strict observance

\*The timetable of the Pittsburgh division is a book of 170 pages, 4 $\frac{1}{2}$  in. x 9 $\frac{1}{2}$  in. On each two facing pages there are columns for 13 trains. Some of the semaphore signals on this division are lower quadrant and some upper quadrant; there are both two-position and three-position signals; and on the main line there are some speed signals—those in which the upper arm on a post indicates regular speed; the second arm medium speed and the third, or dwarf arm, low speed.



of the rules is required, and that no chance taking will be tolerated.

A careful study of the sheet posted monthly, which shows all failures of men and the discipline imposed, as well as commendations for good service, is a great help to all enginemen who make proper use of the lessons.

And now to other railroad companies I would commend the P. R. R. practice of making the men comfortable. Have all gages and the water glass placed close to engineer with a good cab lamp showing on them. Have gage cocks, throttle, reverse lever and sand valve as convenient as possible; a good roof and a comfortable seat, and a storm window 4 in. x 24 in. hinged outside of cab, between the two side windows. This enables the engineer to see while passing trains. He can wipe this window off at any time, and be protected from the weather.

With the Pacific type engine I have had to use brake and use steam going down hill in order to raise the cloud of steam and smoke which hangs over the cab and obscures vision on account of short stack and long boiler. The Atlantic type of engine is much better.

### THE WROUGHT STEEL WHEEL.\*

By D. F. CRAWFORD,

General Superintendent of Motive Power, Pennsylvania Lines West,  
Pittsburgh, Pa.

The development of the wrought steel wheel has been of interest to the managements of the railways from two viewpoints, viz.:

1. Its use as a substitute for the steel tired built-up wheel of various patterns used for passenger equipment cars and locomotive tenders.

2. Its application to freight carrying cars, especially those designed for mineral traffic, instead of the cast iron wheel generally used.

Even in the early stages of the development it was apparent that wrought steel wheels could be produced at prices which would warrant their introduction in lieu of steel tired wheels, and consequently a considerable number of them are now in service under passenger cars and the heavier locomotive tenders. The results obtained in such service indicate equal safety, with decreased investment and maintenance cost, as compared with those formerly used.

While wrought steel wheels are now used in large numbers for freight carrying cars, the length of time in such service has not been sufficient to give really conclusive information as to the relative economy of the wrought steel and cast iron wheels, especially the cast iron wheels conforming to the recently strengthened designs, and made under improved methods of manufacture. The data available, however, indicates that in the wrought steel wheel at present prices the cast iron wheel has at least found a competitor, and that a further reduction in the price of the steel wheel will probably lead to its more extended use for freight car purposes.

Quite a number of the freight cars of 100,000 lbs. capacity, built immediately after their advent in 1898, were provided with cast iron wheels of the lighter designs, and as practically all cars of the capacity named, built in the earlier years, were for mineral traffic, the combination of light wheels and heavy work resulted in more frequent failure and rapid wear than was desirable. Notwithstanding the fact that the weight of the cast iron wheel has been increased from time to time, it cannot be said that cast iron wheels in general use today give as good results for cars of 100,000 lbs. capacity, as were obtained with similar wheels for cars of 60,000 lbs. capacity. These conditions, coupled with the construction of cars having capacities as high as 140,000 lbs. carried on eight wheels, without doubt extended the use of the steel wheel and stimulated production.

As an indication of what service may be expected from the

steel wheel, the records of the mileage of a number of wheels under 100,000 lbs. capacity cars in freight service show that an average of about 180,000 miles per wheel has been obtained without reaching a condition requiring turning. This mileage represents from 18 to 22 years of service under the average freight car.

Accurate information regarding the mileage of cast iron wheels under cars of 100,000 lbs. capacity is, unfortunately, not available, but from records made in 1907 it was found that the average age of a number of wheels removed from service from cars of 100,000 lbs. capacity, was four years, corresponding to a mileage of from 32,000 to 40,000 per wheel. As there can be no question as to the relative strength of an equal section of wrought steel and cast iron, it would seem that for cars of 100,000 lbs. capacity and over, the steel wheel must have preference from this viewpoint.

The Pennsylvania System has followed with interest the development of the wrought steel wheel practically from its inception, and has made use of these wheels in considerable numbers during the entire period of their development. At the present time they are used exclusively for locomotive tenders in passenger service; locomotive tenders, over 5,000 gal. capacity, in freight service; passenger equipment cars in which the weight per wheel exceeds 10,000 lbs., and gondola and hopper cars of 100,000 lbs. capacity and greater, for mineral and mill traffic. The lighter tenders, passenger cars and freight cars of less than 100,000 lbs. capacity, as well as the box, refrigerator and stock cars of 100,000 lbs. capacity, are provided with cast iron wheels.

Up to the present about 325,000 wrought steel wheels have been purchased and the results obtained indicate the desirability of continuing the practice referred to. Of the total purchased, but 328, or about one-tenth of one per cent., have been withdrawn from service on account of breakage or cracks. Of these defects 164 were located in the tread, 69 in the plate, 50 in the plate and hub, and but 45 in the flange. The small number of defects located in the flange is particularly interesting, as it is at this point that the cast iron wheel of the design in general use has the least strength.

The majority of the 329 wheels referred to were used under heavy locomotive tenders, and the results are therefore, representative of the effect of the hardest kind of service. As these defects are those which occurred during the entire period of development of the steel wheel, and the number includes many manufactured under the less perfected processes at first employed, it is to be expected that even a more favorable record will be obtained in the future. In fact the processes now in use should practically eliminate the tread defects, as the larger portion of such defects were undoubtedly due to the effects of "pipes" in the original ingots.

The defects in the plate, and in the plate and hub are probably due to shrinkage strains, and their number clearly shows the desirability of further study as to their cause and the means for their elimination. Quite a large number of the wheels as at first manufactured gave short service on account of lamination of the treads (the same defect was frequently found in steel tires of the smaller diameters), but with the wheels as now made, the number having laminated treads is comparatively small.

On the application of steel wheels to mineral carrying cars it is the practice of the Pennsylvania System to increase the nominal carrying capacity from 100,000 lbs. to 110,000 lbs.; thus increasing the permissible lading from 110,000 lbs. to 121,000 lbs. As there is no doubt of the wheel having ample strength to permit obtaining the full capacity of the axles, this increase in capacity not only adds to the earnings of the cars, but assists in keeping them always provided with a full set of steel wheels, as this kind of wheel only is the standard for cars of over 100,000 lbs. marked capacity.

The construction of many freight-carrying cars of over 100,000 lbs. capacity still further broadens the field for the use of the steel wheel, and makes necessary the further strengthening of the cast iron wheel on the lines already indicated by the makers.

\*Discussion of a paper on the History and Problems of the Steel Wheel presented before the American Iron and Steel Institute, Chicago, October 24, by John C. Neale, structural engineer, Carnegie Steel Company, Pittsburgh, Pa.

# SUMMIT-HALLSTEAD CUT-OFF OF D. L. & W.

The First of Two Articles on a Forty-Mile, Three-Track Line  
Built on a New Location at a Cost of About \$12,000,000.

A grade reduction project which involves some of the heaviest grading and concrete bridge work ever undertaken is now under way on the Delaware, Lackawanna & Western between Clark's Summit, Pa., about seven miles north of Scranton, and Hallstead, Pa., about 14 miles south of Binghamton, N. Y. A general description of this work was published in the *Railway Age Gazette* of April 25, 1913. Although contracts for this work were let early in the spring of 1912, and the contractors on all sections have pushed operations as fast as the best equipment

total cost of the improvement is about \$12,000,000. This expenditure was justified in the preliminary studies by the consideration of the items mentioned in the previous article, including the reduction in grades and the elimination of pusher engines, rise and fall, curvature and distance. The new line will make possible very important operating economies as it reduces the length of line by 3.6 miles and the maximum grade eastbound from 1.23 per cent. uncompensated to 0.68 per cent. compensated, and westbound from 0.52 per cent. uncompensated to 0.237 per cent. compensated. The amount of rise and fall eliminated amounts to 327 ft., the maximum degree of curvature is reduced from 6 deg. 22 min. to 3 deg., and 2,440 deg. of central angle or about 60 deg. per mile are saved by the new line. The third track, which is provided by the reconstructed line for practically the entire distance will also be an important factor in handling the increasingly heavy traffic.

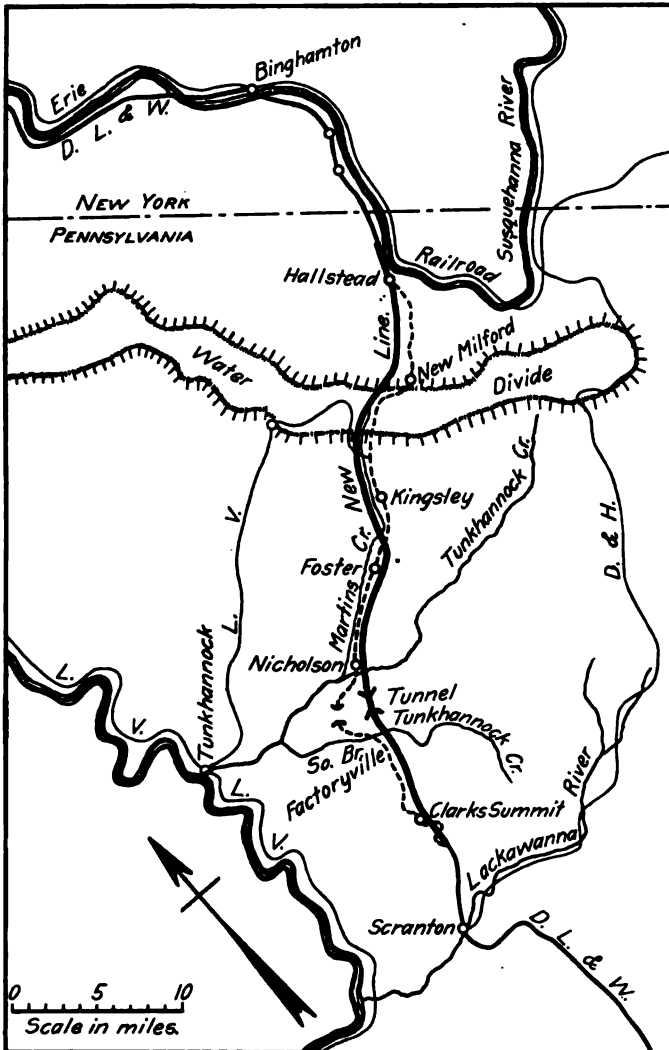

Location of New Cut-Off Between Clark's Summit and Hallstead.

and organizations have made possible, the grading is now only about 50 per cent. completed and bridge work 42 per cent. The following description will deal only with the grading and tunneling. A second article to be published in an early issue will describe the early stages of the bridge work up to the present time.

In the 39.6 miles of new line the excavation quantities reach the high totals of 7,600,000 cu. yds. of rock and 5,100,000 cu. yds. of earth in addition to 146,000 cu. yds. of tunnel and shaft excavation, about 175,000 cu. yds. of earth and 31,000 cu. yds. of rock in masonry foundations and 250,000 cu. yds. of earth and 16,000 cu. yds. of rock for highway realignment, a grand total of 13,318,000 cu. yds., or over 336,000 yds. per mile of line. The

## IMPROVEMENT IN GRADES.

The old line north of Scranton rises on a 1.45 per cent. grade to Clark's Summit, then descends on a 1.23 per cent. grade for six miles to La Plume. For the next 4.2 miles to the Nicholson tunnel, the grade rises at the rate of 0.53 per cent. From the tunnel it descends on a 1.23 per cent. grade for three miles to the crossing of the Tunkhannock creek, near Nicholson, and then ascends the valley of Martin's creek for 18.5 miles on a 0.4 per cent. grade to New Milford summit, from which it descends for nine miles to Hallstead on an irregular grade having 0.89 per cent. as a maximum.

This line is used by an average of 26 passenger and milk trains, 16 manifest freight and 31 slow freight trains daily. The maximum tonnage for slow trains in both directions, is 3,825 tons for the heaviest mikado locomotives, and 2,750 tons for the other engines, this tonnage being fixed by the grades on the remainder of the engine district which extends from Scranton to Elmira. On the section between Scranton and Hallstead eastbound trains with the maximum tonnage now require two pusher engines from Hallstead to New Milford, and three helpers from Nicholson to Clark's Summit. Westbound trains now require four helpers from Scranton to Clark's Summit, and one from Clark's Summit to New Milford.

The new improvements do not affect the grade between Scranton and Clark's Summit, as Scranton is located in a deep valley with rising grades on all sides, and the reduction of grade on this section would have required excessive length and curvature. From Clark's Summit north the new line descends on a 0.682 per cent. grade for 6.4 miles, and from there to the Tunkhannock creek crossing the grade is 0.2 per cent., except through the tunnel and approaches where it is reduced to 0.15 per cent. From Nicholson to New Milford summit the line ascends on a 0.237 per cent. grade and from there to Hallstead it descends on a grade of 0.61 per cent. The new and old grade lines cross a short distance on each side of the summit, the new summit being 16½ ft. lower than the present one. The maximum tonnage trains on this new grade will require only one pusher from Hallstead to New Milford, and one from the Nicholson tunnel to Clark's Summit. All pusher service will be eliminated westbound, except that between Scranton and Clark's Summit, which, as explained above, will remain the same as at present.

## CHANGES IN LINE.

The new work begins about one mile south of Clark's Summit station, the new line crossing the old twice at a grade which is 29 ft. below the old at the Clark's Summit station. This summit cut is about two miles long and from 20 to 60 ft. deep. Near the north end of this cut the new line swings away from the

present one, reaching a maximum divergence of about 1.5 miles near Factoryville, and returning to within a few hundred feet at Nicholson. The old line between Clark's Summit and Nicholson follows the drainage, while the new line cuts across it at right angles, requiring numerous cuts and fills exceeding 100 ft. in depth. The south branch of the Tunkhannock creek is crossed on an embankment 140 ft. high, requiring 1,600,000 cu. yd. of material, and the divide between the north and south branches of this creek is passed in a double track tunnel 3,630 ft. long, with approach cuts aggregating 1,000,000 cu. yds. of excavation. The new line will be carried over Tunkhannock

slopes, requiring heavy work to keep within the standard of curvature, which is 2 deg. wherever possible, with a maximum of 3 deg. in three instances. From New Milford to Hallstead the work is much lighter, the improvement ending about two miles north of the Hallstead station.

CONTRACTORS AND GENERAL METHODS.

For construction purposes the work is divided into ten sections which are being handled by the following contractors:

- Section 1—Robert Grace Contracting Co.
- Sections 2 and 3—Reiter, Curtis & Hill.
- Section 4—D. W. Flickwir.

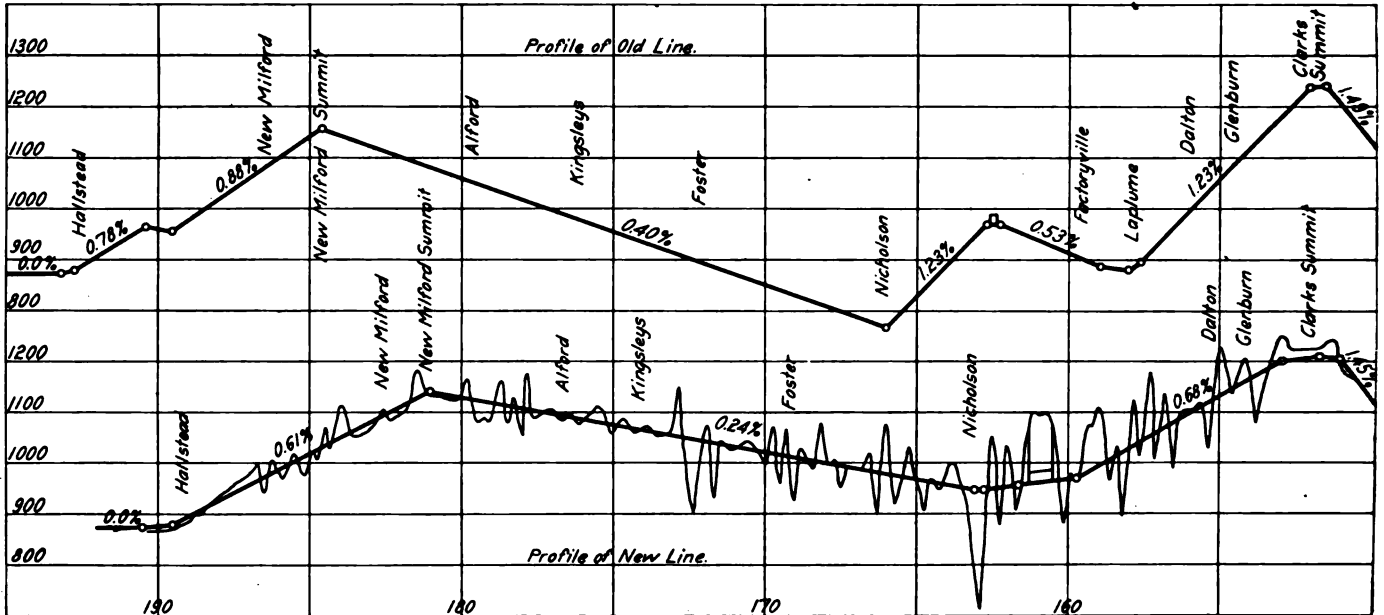

Profile of Old and New Lines North of Scranton.

creek valley on a long concrete arch viaduct on which the top of rail will be 240 ft. above the bed of the stream. Between Nicholson and Kingsley the new line lies high up on the east slope of Martin's creek valley, and is nowhere more than a few hundred feet from the present tracks which are on the same side of the valley. Near Kingsley the new line crosses the present tracks and the stream on a concrete arch bridge similar to the Tunkhannock structure. The top of rail on this bridge is 150 ft. above the bed of the stream and 88 ft. above the old tracks. The Martin's creek valley is very narrow with steep and irregular

- Part of Section 5—Flickwir & Bush, Inc.
- Part of Sections 5 and 6—Waltz & Reece Construction Co.
- Part of Section 6—James A. Hart Co.
- Section 7—Timothy Burke.
- Section 8—F. M. Talbot Co.
- Section 9—P. McManus.
- Section 10—W. H. Gahagan.

On account of the unusual proportions of all of this work only the heaviest and most improved machinery is employed in its prosecution. The contractors are using 30 steam shovels in making the excavation. Three dumping cableways have been



Ackerly Fill, Showing Clark's Summit Cut in Distance.

built for making high fills, and in at least two cases an unusual method of handling loaded cars from a cut down to the lower level of a high fill has been introduced. One of the most striking features of this work is the use of steam shovels for excavating masonry foundations, in lowering highways for under-grade crossings and other comparatively small jobs ordinarily handled by teams. One contractor who used a 30-ton Thew

being three cuts over 100 ft. deep and five fills over 100 ft. high. There are six cuts and eight fills with a yardage of over 500,000 yds. each.

THE ACKERLY FILL.

It is only necessary to describe a few of the more important cuts and fills to indicate the magnitude of the work and the

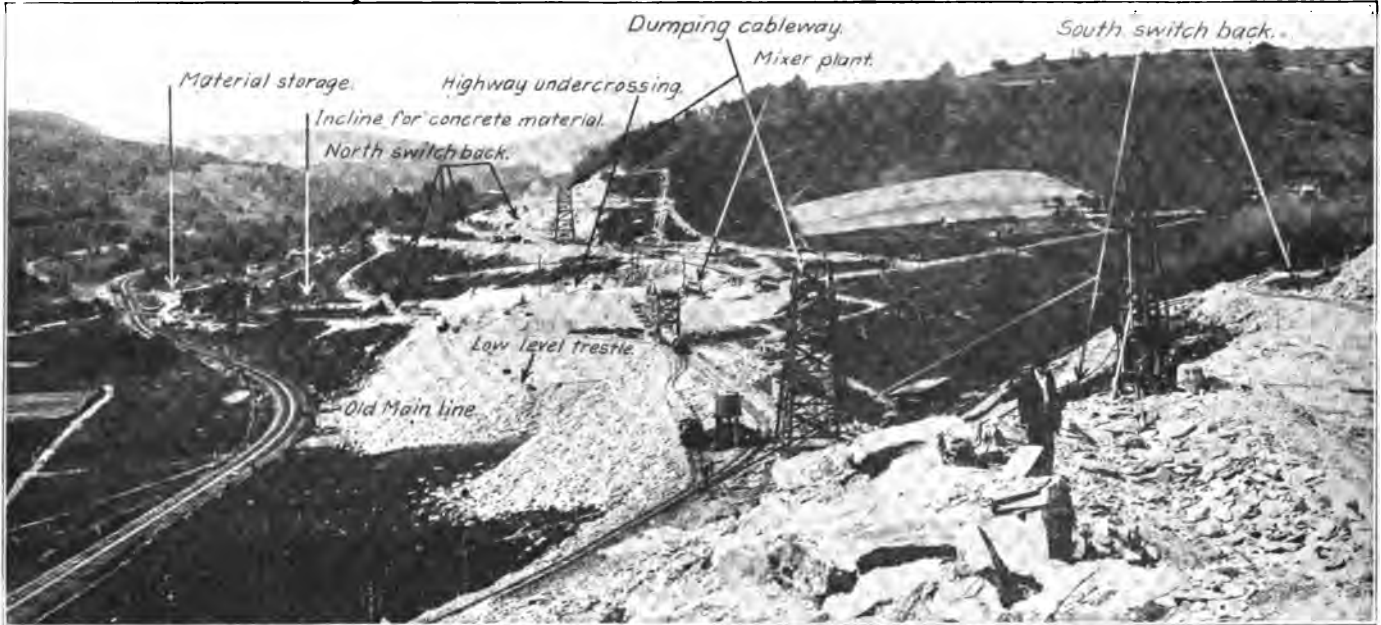

Looking North Over Riker Fill, Showing the Two Methods of Placing the Embankment, also the Concrete Plant for Building the Highway Arch.

shovel with a 1/2-yd. bucket for road and foundation excavation found that it worked very economically, especially in consideration of the high rate paid to labor on this work. As has been mentioned, deep cuts and high fills are very common, there

methods used in handling it. The Ackerly fill, which is located on the first section, contains 830,000 yds., and has a maximum height of 115 ft. On account of the extreme height the contractors used a dumping cableway for making this fill, intro-



Slayton Cut and Switchback to Fill in Foreground.

ducing an added advantage by dumping at both ends. This cableway had a maximum length of 2,200 ft. between anchors which length in itself is very unusual.

Instead of moving forward one end tower as the fill progressed, a third movable tower was used and the main towers allowed to remain fixed. The movable tower was kept close to the end of the fill to support the cable close to the dumping point. The cars were backed out on a track suspended from the two cables in the same manner as in cableways previously used. The dumping was carried on for a considerable time from one end in the usual manner, but in order to hasten the work it was decided to dump from both ends. When this method was first tried some difficulty was occasioned by the slack in the cable between the movable and the main towers. When a train of ten loaded cars was run out on the cableway this slack would all be pulled over the tower, and the weight of the cable itself would cause the slack to run back when the weight of the train

#### THE SMITH FILL.

The Smith fill, having a maximum height of 120 ft. and containing 540,000 yds. of material, was made in two stages by trestling. An unusual method had to be adopted here to handle the material while the roadway arch under the deepest point of the fill was being constructed. A large part of the material had to be taken out of the Slayton cut north of the fill and carried over the uncompleted arch to make the south end of the fill. The first trestles were built at various angles south of the concrete arch to utilize as much of this material as possible in carrying out the base of the fill to its full width. In the later stages of the work a second trestle was built on the newly made fill and dumping was carried on simultaneously on both levels. In order to get the narrow gage dump cars across the gap in the fill, which had to be left open for highway traffic, without building a temporary trestle up to the grade of the adjacent cut, these cars were dropped down a steep incline from the cut and



One End of Cableway at Riker Fill, Showing Movable Intermediate Tower.

was removed. By cutting the train and dumping five cars at a time it was possible to work at both ends by alternating so that the weight of both trains would never be on the cable at the same time. In order to eliminate this difficulty the cable back of the movable tower was finally anchored by short cables to dead men, allowing trains of ten cars to be dumped at either end, although at the time the accompanying illustration of this cableway was made, cars were only being dumped on one end. This fill is on a 2 deg. curve, which is shaped in widening. It will be made wide enough for four tracks in order to use the material from the long cut through Clark's Summit, which contains 1,450,000 yds. The old line opposite this fill included a 5 deg. curve with 180 deg. of central angle, the lack of compensation for curvature increasing the grade at this point to about 0.75 per cent.

run across a trestle which was just high enough to clear the new arch. A cable system was used on this incline by which a string of empties at the bottom was pulled up by the loads coming down. A similar system will be described in more detail for the South Branch fill. A dinky engine picked up the loaded cars at the bottom of the incline, pulled them across the trestle and back onto the new fill whereby a series of switch backs the high or low dumping trestles were reached. The situation is shown quite plainly in the two accompanying photographs.

#### SOUTH BRANCH FILL.

The largest fill on the line was across the south branch of Tunkhannock creek. The maximum depth of this fill is about 145 ft., and the yardage is approximately 1,600,000. On account of the extreme depth of this fill it is necessary to make the

deepest portion in three lifts, and an unusual method of placing the first lift was adopted. A large part of material comes out of the Crisman cut just north of the big fill, and in order to get this material down to the level of the first lift a balanced incline system, similar to that mentioned in the description of the Smith fill is being used. At the top of the slope from the new cut a pair of hoisting drums equipped with a friction brake are located between the narrow gage tracks leading from the

point the line is benched in a side hill above the old line, which is shown to the left. The material for the fill was secured from the Shick cut adjacent on the south, and the Capwell cut on the north. The excavation was carried on in these cuts simultaneously, a cableway being used on the south end, and a long switch back leading to a low level trestle dump on the north end. A switch back also had to be used on the south end to carry the material down from the top levels of the cut to the



**Smith Fill Under Construction Showing Two Heights of Trestles.**

cut. These tracks are located so that cables attached to cars on the incline can be run directly to the drums. A train of loaded cars coming from the cut is pushed to the head of the incline and attached to a cable from one drum. At the same time the other cable is attached to a string of empties waiting on the fill at the bottom of the incline. The loaded cars are then allowed to run down the incline, pulling up the empties, the speed being regulated by the friction brake on the continuous axle of the two drums. As the bottom of the fill is 472 ft. wide a circular track was laid from the bottom of the incline so that the

dumping cable which is at grade. These switch backs are clearly indicated in the illustration.

**CUTS.**

The Slayton cut, which is the deepest through cut on the line, is shown in one of the accompanying photographs. This cut contained 420,000 yds. of material, the maximum depth being 115 ft. The maximum haul of material from this cut was about one mile. Another of the deepest cuts is encountered in the side hill work in the Martin's creek valley, where a center height of



**South Branch Fill, Showing Balanced Incline to Lower Lift and Upper Level Trestle.**

cars could be handled by a dinky to any desired part of the fill. The upper lifts of the fill will be made from trestles, one of which is shown in the accompanying photograph.

**THE RIKER FILL.**

The work on the Riker fill is unusual on account of the variety and number of operations which have been carried on simultaneously in prosecuting the work. This fill is 1,600 ft. long with a total yardage of 500,000. The accompanying photograph shows the method of handling this work very clearly. At this

114 ft. and a maximum height on the upper slope of 167 ft. is obtained. The yardage in this cut is 480,000. No unusual methods of excavation were adopted, as in most cases the rock which was encountered broke up very well when sufficiently heavy charges of powder were used.

**NICHOLSON TUNNEL.**

The double track tunnel carrying the new line through the ridge between the two branches of Tunkhannock creek is 3,630 ft. long. It is being driven from two shafts located at the third

points. These tunnel shafts were excavated 34 ft. x 54 ft., and lined with concrete 2 ft. thick, making the inside dimensions 30 ft. x 50 ft. The shafts are about 135 ft. deep, the upper 30 ft. being through earth and the remainder through rock. They will be provided with chimneys 20 ft. above the ground surface to induce ventilation in the tunnels to remove the locomotive gases.

As the tunnel cuts were not completed before the shafts were sunk headings were started in both directions from these shafts, and additional headings will be driven from the portals as soon as the cuts have been made. These headings are 7 ft. x 8 ft. in cross section and will be enlarged to the full width later. The material removed from the shaft headings was at first brought up in 2-yd. scale boxes by a derrick having a boom about 86 ft. long. Subsequently elevators were established in both shafts, the muck being transported from the headings in Koppel cars and discharged into buckets at the foot of the elevators, which in turn are dumped automatically into chutes at the top of the elevators, the chutes discharging into cars at the surface for removal to spoil banks. Electric locomotives will be used to haul the material to the shafts as soon as the headings have been driven far enough to warrant it.

The tunnel cross section is 8 ft. 5 in. from base of rail to springing line, the arch having a radius of 18 ft. 6 in., where

**PRIVATE CAR TROUBLE IN ENGLAND.**—After the end of this year no freight cars will be allowed on the railways in Great Britain which are not fitted with spring buffers. This is in accordance with a notice issued by the Clearing House seven years ago; but it is said that the proprietors of coal mines have from 8,000 to 12,000 wagons still in use which have only "dead" buffers—those not fitted with springs. What can be done with these cars after December 31 is a question which now gives rise to some anxiety.

**NEW BULGARIAN RAILWAY.**—Now that peace has been declared between Turkey and Bulgaria, the first consideration of the Bulgarian government will be the construction of a national railway linking up Old Bulgaria with the Ægean sea, through Bulgarian territory, as the old line to Dedeagatch traverses Turkey. A recent cabinet council, presided over by the king, decided in principle on the construction of the line. It will start from a station on the Philipopolis-Adrianople line, will pass through Haskovo and Kirdjali, and terminate at Porto Lagos. According to official estimates, the construction of this line, to be 108 miles long, will cost \$5,000,000, and will require three or four years to build, owing to the engineering difficulties to be overcome.

**THE ARGENTINE AMALGAMATION.**—The main reason for the sudden withdrawal of the bill for amalgamating the Buenos



Smith Fill, Showing Balanced Incline and Second Level Dumping Trestle.

timbering is required and 17 ft. where the material is self-supporting. The subgrade is 2 ft. below the base of rail, with a ditch 1 ft. deep on each side. Where lining is required it consists of a four-course vitrified brick arch resting on a concrete wall 2 ft. thick below the springing line, faced with one course of vitrified brick bonded to the concrete. The net section of this tunnel requires the excavation of about 30 yds. per lineal foot. Blue and red sandstone and red shale are encountered in alternating layers of various thicknesses. All of the rock is horizontally bedded.

The entire work of building this cut-off was planned and is being executed by G. J. Ray, chief engineer. F. L. Wheaton is engineer of construction in immediate charge of the work.

**SWISS FEDERAL RAILWAYS.**—The latest statistics of the progress of the Swiss Federal Railways during the last 10 years, 1903-12, have just been issued. They show that the railway mileage in that period has increased by 31 per cent., the receipts from passenger traffic by 49 per cent., and from freight traffic by 54 per cent. The number of passengers carried increased by 64 per cent., and the number of tons of merchandise by 46 per cent.

Ayres Great Southern and the Buenos Ayres Western railways was due to the competitive policy of the Buenos Ayres Provincial Government. That much was made clear in the exhaustive speeches on the subject which the chairmen of the two companies delivered to their respective shareholders at the ordinary general meeting. The decision of the provincial government to introduce a bill in the legislative chamber to empower them to construct a net work of 8,000 miles of lines in connection with the narrow gage railway they have been engaged in building for several years past from La Plata to the western boundary of the province came, as Mr. Simson expressed it, like a bolt from the blue. The idea of the provincial government was to cross and recross the two companies' existing lines with the object of controlling them and preventing their obtaining a monopoly and abusing their position by charging prohibitive tariffs, although the Mitre law amply provides against any such contingency. In the circumstances, the directors' decision to withdraw the amalgamation bill is not to be wondered at. Mr. Simson, however, takes a hopeful view of the situation, and is convinced that the sense of justice and fair play which characterizes the majority of the Argentines will ultimately prevail and that the province of Buenos Ayres will not give effect to its proposals.

# EASTERN TRAINMEN'S WAGES SETTLED.

Messrs. Low and Finley Advance Wages Because of Increase  
in Cost of Living. Many Demands of Employees Denied.

The arbitrators under the agreement of July 26 last, Seth Low, John H. Finley, W. W. Atterbury, A. H. Smith, L. E. Sheppard and D. L. Cease, chosen to consider the demands of the conductors and trainmen of 41 eastern railroads, issued their award on Monday last and filed it in the United States District Court, in New York City, in accordance with the law under which the arbitration was undertaken.

This settlement affects about 20,000 conductors and 80,000 trainmen, and the average of the increases awarded amounts to 7 per cent. The operating expenses of the railroads amounted in 1912 to \$748,892,071, and the payments in wages to conductors and trainmen amounted to \$85,646,080. The population of the district served by the forty-one railroads is 47,000,000. The increase asked for by the employees was estimated at \$17,975,688. It is estimated that the gross increase will be about \$6,000,000.

Dissenting opinions were filed by Messrs. Atterbury and Smith, and also by Messrs. Sheppard and Cease. The most vital questions were settled by the votes of Messrs. Low and Finley.

Following are the salient passages of the report, which fills 75 pages:

Both the Order of Railway Conductors and the Brotherhood of Railroad Trainmen accept the open shop, and these brotherhoods neither believe in nor practice the sympathetic strike, and conductors and trainmen not affiliated with the organizations were taken into consultation at every stage of the proceeding; so that it must be assumed that the propositions submitted for arbitration represent the views of substantially all the conductors and trainmen in the employ of the railroads concerned.

It is important to consider whether the present demands begin a new cycle, so to speak, on the part of the railroad train employees for a further advance in wages; or whether the conductors and trainmen are closing an old cycle during which the engineers in 1912, and the firemen in 1913, received advances which the conductors and trainmen have not yet received. It is the prevailing opinion of the Board that the present movement is the close of an old cycle and not the beginning of a new one.

*Territorial Differentials.*—These movements usually move in cycles; for if one brotherhood obtains an advance the others have usually asked for a corresponding advance; but this is only one phase of the wage problem with which the railroads have to deal. By custom the railroads and the brotherhoods have recognized that the railroads of the United States are divided into three wage zones, the eastern, the southern and the western. The wage scale in the eastern territory has always been less than the scale paid in western. Until 1910, the wage scale in the southern territory had always been less than the wage scale either in the eastern or in the western territories. It has been for many years the object of the organizations engaged in this arbitration to obtain in the eastern territory the same scale of wages as prevails in the West.

As between conductors and trainmen a satisfactory differential has been reasonably well established. In passenger service it is agreed by the men that a brakeman should receive approximately 60 per cent. of the wages of a conductor; and in the freight service 66⅔ per cent. has been agreed upon. . . . This Board believes that before a standardization of pay for conductors and trainmen can be brought about between the East and the West, the organizations concerned should formally and officially commit themselves to the policy of standardization between East and West. In the absence of such an accepted policy, were this Board to place the pay in the East on the western basis, such an increase might serve to bring about a

new movement in the West to secure the old differential as against the East.

*Independent Inquiry Recommended.*—Some public authority authorized by the Congress should make an independent inquiry as to whether there is any longer any substantial reason for the maintenance of a wage differential between the West and the East; whether there can be a scientific basis for the payment of railroad employees who operate trains. The body making such inquiry should not attempt to fix wages; only make a study of the proper basis for the fixing of wages. Neither is it suggested for a moment that wages, when agreed upon by any process, should become unchangeable; but by the process suggested, some of the artificial embarrassments to the equitable adjustment of railroad wages could be removed. It is possible that the Commission on Industrial Relations recently appointed by President Wilson may be competent to carry out the suggested inquiry.

*Recent History.*—So far as the conductors and trainmen are concerned the year 1910 marks a new epoch in the East and South. In that year collective movements were undertaken both in the eastern territory and in the southern. The conductors and the trainmen's demand on the Baltimore & Ohio for the rates of pay then prevailing in the western territory became the subject of mediation under the Erdman Act, and the existing rates of pay now prevailing in the eastern district, with some modifications, were established by agreement in that proceeding. Both conductors and trainmen got substantial increases, but not the full western rates then prevailing. Following this agreement the conductors and trainmen obtained substantially the same rates and conditions on most of the other roads of the eastern territory. This was accomplished by agreement in some cases, and in others as the result of what is called the Clark-Morrissey award in the case of the New York Central.

Among the rules of service thus agreed upon were these: (1) that, in the passenger service, pay should be based on a day's run of 155 miles; (2) in freight service on a run of 100 miles; (3) that consecutive time should be paid for, beginning from the time when the man reports for duty; (4) that overtime should be paid for at hourly rates and by the minute. With inconsiderable exceptions these rules now prevail on all of the 41 roads embraced in this arbitration. Following the settlement with the railroads of the eastern territory, the conductors and trainmen began a collective movement in the southern territory. This movement also began in 1910. When concluded, the railroads in the southern territory had agreed to all of the foregoing rules, and to that extent standardization of rules affecting pay now prevails between the East and the South. As a result of another collective movement in the South, in 1912, the rates of pay for conductors and trainmen were fixed for the first time at a point higher than those now prevailing in the eastern territory, but lower than those now prevailing in the western territory. Some of the rules affecting pay established for the South are more favorable than the corresponding rules to be found in either the eastern territory or the western.

*Existing Differentials.*—Since 1910 the railroads of the western territory have granted a 10 per cent. advance to all of their employees in train service, and the engineers in the western territory enjoy a wage scale that is 5.3 per cent. in excess of the engineers' wage scale in the eastern territory as determined by the arbitration of 1912; the firemen in the West, a wage scale that is 7.3 per cent. higher than the firemen's wage scale in the East, as determined by the arbitration of 1913; the conductors in the West, a wage scale that is 16.1 per cent. higher



than the conductors receive in the East, as determined by the adjustments of 1910; and the brakemen in the West, a wage scale that is 7.1 per cent higher than the brakemen's wage scale in the East, as determined by the adjustments of 1910. The differential in favor of the western brakemen would be much larger, except for the fact that the wage scale of yard brakemen in the eastern territory in the first class yards is within 2½ per cent. of the wage scale of yard brakemen in the western territory. Inasmuch as the yard brakemen constitute 32 per cent. of the total number of brakemen, the effect of this small differential in yard service is palpable. The same situation exists with reference to conductors in yard service. It is, therefore, apparent that the existing spread between the East and the West as it affects conductors outside of the yard service is very large.

*Increase Requested.*—This is an outline of the situation existing in the various railroad territories at the time when this arbitration began. This arbitration affects about 100,000 men (as before stated) and the vast importance of the interests directly affected is evident. A remarkable series of exhibits have been prepared for use in connection with this arbitration. The information submitted by the men has been compiled from the reports of the Interstate Commerce Commission, with great carefulness, by Frank Warne, a trained statistician, who has been engaged upon this work for approximately nine months. The statistics submitted by the railroads have been prepared in part from the reports of the Interstate Commerce Commission, and in part from their own records, with equal thoroughness, by a sub-committee of the conference committee of managers. The Board is not to be held responsible for the conclusions claimed to be established by these figures by either one side or the other; but the Board takes pleasure in calling attention to this remarkable body of information in regard to the railroads of the country. This careful and comprehensive study of the whole situation by the parties to the controversy goes a long way to justify these collective movements for the adjustment of pay and conditions of service. No study of this character was possible so long as each railroad was dealt with by itself; and it is probable that the ultimate outcome of this method of procedure, when every detail is seen in the light of the larger situation, will be more wise and more just to all the parties concerned than any result that could possibly be reached by an indefinite number of smaller proceedings.

*Review of Argument.*—In brief, the men ask that they be given the western rates of pay while retaining the rules and regulations affecting pay prevailing in the East. For example, in the West men are paid by the month on the basis of varying standards of monthly runs; in the East they are paid by the mile and by the day. This difference in method of payment makes an exact comparison between eastern and western rates of pay impossible. The proposals submitted for arbitration also ask for certain new rules, such as time and a half for overtime, which at present do not prevail in any of the three territories. All of these rules, if adopted, would still further increase the rates of pay established.

The men ask for the western rates of pay:

- (a) In the name of standardization;
- (b) On account of increased cost of living;
- (c) On account of increased risk, labor and responsibility;
- (d) On account of the increased productivity of the work of a train crew;
- (e) On the ground that the profits made by the railroads in recent years have increased out of proportion to wages.

*Standardization.*—The men urge standardization on the general ground that railroading "per se" is worth just as much in one part of the country as in another, with the exception of the so-called mountain district in the western territory where permanent natural conditions justify now and may justify always a differential in favor of that district. It is declared that the essential conditions affecting the lives of railroad men in the operation of railroads are substantially identical in all three territories; that

with local variations a man could live within a thousand miles of Chicago, east, west or south, and enjoy in all of the reasonably settled parts of the country the same privileges and opportunities in one territory as in the others. The cost of food and other necessaries would equalize themselves wherever a man lived, while a man would find as many of the opportunities that go to make life enjoyable and pleasant in one territory as in another. Rules and practices are constantly becoming more and more alike. The average time on duty of conductors and trainmen in the East is distinctly longer than in the West.

The answer of the railroads urges that there is no such thing as standardization of rates and rules in any one railroad territory, much less as between territories, because the rules differ everywhere. In the eastern territory the railroads admit that there is a fair approximation to standardization within the territory, both as to rates and rules affecting pay, except that there are high spots which the men will not permit to be leveled down for the sake of standardization, and low spots which have been established by arbitration. The railroads admit that in the western and southern territories the daily rates of pay are higher; but claim that the rules affecting pay are almost as diverse in these two territories as the roads concerned. The roads admit that in the eastern territory a man must work longer hours, but the generally higher standard of equipment of the railroads, as compared with other territories, offsets the disadvantage to the men of longer hours by making the work lighter and less dangerous.

The railroads also urge that the statement of time consumed in the different territories is not comparable, without taking into account the overtime rules, and it is urged that the greater length of time apparently demanded of the men in the eastern territory, may be due to payments for preparatory time, for terminal overtime, and for overtime for special work, on a more favorable basis in the East than in either the southern or the western territories.

The railroads also show that the receipts per ton mile and per passenger mile in the three territories compare as follows:

	Ton Mile.	Passenger Mile.
Eastern .....	.646	1.779
Southern .....	.709	2.160
Western .....	.96	2.139

The railroads further show that the conductors and trainmen in the eastern territory receive for each ton-mile or passenger mile more than they receive in either the southern or the western territory.

Both of these results the railroads claim spring from the large number of short runs in the eastern territory, due to the greater density of population, runs for which a full day's pay is paid, although the run is less than the basic passenger run of 155 miles, or the basic freight run of 100 miles.

The railroads also challenge the justice of the wage scales existing in the West and in the South, as not having been proved; and for this reason they urge that to standardize wages in the eastern territory with wage scales that may themselves be inherently unfair, is both unwise and unjust. The railroads claim that these scales have been established, by the processes already described, and that these scales, therefore, are entitled to no consideration as standard scales.

*Finding as to Standardization.*—The Board must take the adjustment of 1910 as its starting point; it cannot be controlled by the argument for standardization, although it may be influenced by it. Standardization as to pay and rules, as between the eastern territory and the western territory, is at the present time impossible. Not only is the differential between the two territories as it affects the conductors and trainmen very large, but it is not clear that the policy of standardization which is favored in the East is responded to by the conductors and trainmen of the West. . . . The policy urged by the men in this regard is in the large interest of the railroads as well as of the public; so that progress should be made in this direction as fast

as circumstances will permit. In the universal conception of the day, interstate railroading is a national public utility; being such, uniform rates of pay for the same class of service are likely to prevail, sooner or later, in all parts of the United States where permanent natural conditions do not forbid. . . . The rates which railroads are permitted to charge, both for passengers and freight, must in the opinion of this Board be adequate ultimately in all parts of the country to permit uniform rates of pay to be paid. The Board recognizes that freight rates and rates of pay have no direct connection with one another; because freight rates between competitive points are really determined by the competition. This Board has done what it properly can to standardize rates of pay between the eastern territory and the southern. This appears to be the more justifiable because wages in other trades in the South and in the East are substantially the same. From what has already been said, it is clear that the rules affecting pay in the eastern territory and in the southern territory are already standardized to a considerable extent. It may be broadly said, therefore, that, as a result of this proceeding, the rates of pay and most of the fundamental rules will be substantially standardized in the greater part of the service from the Mississippi to the Atlantic Ocean.

*Increased Cost of Living.*—The men make an exhibit showing the increased cost of food during the last decade. The railroads contend that this arbitration board should accept the adjustments of 1910 as the starting point; and they maintain that there has been no increase in the cost of living since that adjustment that would warrant any increase of pay at the present time; but they have not attempted to establish this claim by testimony.

The small amount of evidence presented by either side as to this subject has compelled the Board to reach its own conclusions from the unchallenged testimony as to the increased cost of food between 1909 and 1913. The Board assumes that the agreement with the Baltimore & Ohio which was made March 1, 1910, took fairly into account the cost of living as it stood at the end of 1909. Bulletin 132, Bureau of Labor Statistics, shows that the cost of living has increased at least 7 per cent., for men having incomes from \$800 to \$1,200 per annum. The Board therefore finds that there has been a substantial increase in the cost of living since the adjustment of 1910.

*Increased Risk, Etc.*—The men claim increased risk, labor and responsibility because of the longer trains and the larger cars, and in particular because of the great increase in certain parts of the eastern territory of the practice of using one train crew with two, three, four, and sometimes even five large engines.

The railroads admit the increase in length of trains, etc., but claim that the change from wood to steel in the construction of cars, and the installation of safety appliances, such as automatic couplers, airbrakes, and interlocking switches, have offset any increase of risk, etc.

The opinion of the Board is that the elements of risk and labor growing out of increased size of train and cars are practically offset by the safety appliances, etc. Employees' Exhibit, No. 4, shows down to June, 1909, the percentage of trainmen injured, including killed, in the eastern territory and in the United States as a whole, per thousand trainmen employed. These statistics seem to justify the conclusion that the number of trainmen killed on American railways is steadily decreasing in proportion to the number employed; and that in the eastern territory it is decreasing actually as well as proportionately.

It is not clear that the duties of the brakemen are any greater now than they were three years ago, but there has been a certain increase in responsibility placed upon the conductor with the increased length of passenger trains and the increased size of loads on freight trains, and the Board has taken this into account by increasing the pay of conductors in some instances more than it has increased the pay of brakemen.

*Increased Productivity.*—The men claim that the increased productivity of a train crew when caring for larger trains and

heavier loads than formerly is self-evident; and some portion of this saving should by right be given to the train crew.

The railroads ignore this argument, holding that any such increased productivity, whatever it may be, was met as it accrued in the wages fixed in 1910. They submit figures to show that conductors and trainmen receive more now per traffic unit than they did formerly.

It is the prevailing opinion of the Board that the extra productivity of the train comes from the increased number of engines, in connection with each of which an engine crew is paid for, and not to any measurable extent from any contribution to extra productivity by the train crew itself. This method of operation does not devolve upon the train crew, ordinarily, any increase of risk or any increase of labor under modern conditions, though the Board does recognize some increase of responsibility. In mine service, in some places, in which a train is drawn by two engines, a train crew is sometimes broken up in order that each half of the crew may serve each engine separately. In such service the prevailing opinion of the Board is that the train crew, as distinguished from the engine crews, does contribute to the increased productivity of the train, and the Board has had this reason in mind in transferring mine service, in the matter of pay, from the basis of the through freight service to the basis of the local freight service which is higher.

*Profits and Wages.*—The men have submitted carefully prepared tables which show that the railroads in the eastern territory are much more profitable than they were ten years ago. The railroads disregard this argument, but have pointed out that fixed charges are constantly being increased.

The Board has been both interested and instructed by these exhibits, but the railroads have made no plea of inability to pay, and the Board finds itself unable to relate the facts contained in this class of exhibits to the question of wages in such a way as to found thereupon specific increases in rates of pay.

*Miscellaneous.*—The railroads declare that the conductors and trainmen already receive much better pay than other skilled labor. The conductors and trainmen challenge the bearing of this exhibit, without further development, and point out that their occupation is exceptionally hazardous; that they are unable to buy life insurance, so that they are obliged to furnish it through their own organizations on the mutual plan; that more than one in ten of all trainmen, including in this term with the conductors and brakemen the engineers and firemen, is injured every year; and that, while, the railroads often keep men in their employ until they are old, the men if they receive an injury, or if they are dismissed for cause, find it exceedingly difficult to continue in the railroad business, except at greatly reduced pay, if at all.

The men claim that the conductors and trainmen receive larger pay per mile in the eastern territory than in the western, that the pay per mile traveled does not afford a fair comparison; because the comparison thus made is on a mile basis, while, as a matter of fact, the railroads in the eastern territory practically pay on an hour basis, and the railroads in the western territory on a basis of mileage. In the month of October, 1912, in the fast through freight service, the men were on duty nine hours and thirty-eight minutes, while in the slow freight service they were on duty eleven hours and forty minutes; in the local and pick-up service twelve hours and four minutes.

The railroads further urge that on account of the full crew bills passed by a number of the legislatures, any increase of pay given to brakemen constituting such crews should be so adjusted as to provide for lower rates of pay to each of the two brakemen than was formerly given to the one brakeman. To this the men reply that such legislation exists in twenty states of the Union, and that of these states only five are in the eastern territory, and that in the other fifteen states no such discrimination as to pay is made.

In regard to the argument that the conductors and trainmen already receive much better pay than other skilled labor, the Board is of the opinion that the offsets suggested by the men as

to the risks of their occupation, and the necessity which is upon them to insure themselves because they cannot buy insurance, are a sufficient answer. It is to be said, moreover, that the traveling public, as well as the employees themselves are dependent for safety upon the efficiency and fidelity of the brakemen as well as of the conductor. It is distinctly in the public interest that the men entrusted with such a charge should be well paid; for unless they are, the service will fall into the hands of men less capable of doing it well. In his closing statement for the railroads Mr. Elisha Lee says: "All will, of course, agree that the first charge upon railway revenue must be fair payments to employees."

. . . The men in the East are obliged to work from one hour to two hours a day longer than they do either in the West or in the South to earn the same money. The lay members of the Board are unable to express a technical judgment upon the question; but they confess themselves perplexed by being told that where population is greatest and cities nearest to each other, and where the amount of freight to be handled is the largest, that there the men should find it necessary to work longer hours than in the more sparsely inhabited parts of the country in order to earn the same amount of money.

In regard to the full crew bills the prevailing opinion of the Board is that it is not the function of the Board to attempt to correct mistakes of the legislature, if such mistakes have been made. It is in the interest of all concerned that any modification of the existing situation should be brought about by agreement between the management and the men, if possible.

*Overtime.*—The men have asked for a new rule to provide for the payment of overtime at time and a half, instead of as now, pro rata. The Board is in sympathy with the expressed desire of the men to reduce overtime as much as possible, and it recognizes that the payment of time and a half for overtime is a well-established custom in the building trades and possibly in some other trades. But, wherever it prevails, so far as the Board is aware, the determination as to whether overtime shall or shall not be paid for, rests with the employer. In railroading, it is quite evident that in many cases neither the management nor the trainmen can prevent overtime; and it appears to this Board, therefore, that punitive overtime, as it is called, is an unsound principle when applied to the running of trains. The Board hopes that some other method can be devised for reducing overtime; for it does earnestly believe that the hours demanded in slow freight and construction service are unreasonably long. If no other remedy can be found, possibly punitive overtime should be tried; but this Board does not deem it wise to adopt this rule at the present time.

As to overtime in yard service, the intermediate members of the Board are less clear, because they are less sure that overtime in yards is beyond control of the management. They have declined the rule in yard service, however, partly because it has been recently disallowed by an arbitration in Illinois, and partly because, not being itself sure, it has seemed to the Board unwise to disturb existing arrangements.

*Passenger and Freight Rates.*—This Board has no authority to determine the passenger and freight rates to be paid in the eastern territory; and must make its finding as to what is a proper rate of pay without any reference to the dilemma in which the railroads are evidently placed by the laws which make it impossible for them to increase passenger and freight rates. . . . To take any other view of the question would be to decide that no increase of pay, while the laws remain as they are, can ever be made except voluntarily by the railroads. We have the cheapest railroad service to be found on the face of the globe. In the face of such a fact, it would be unjust to say that railroad employees must continue to be satisfied only with what can be paid from freight rates as low as ours.

*Safety.*—One other factor this Board believes should be called vividly to the attention of the Interstate Commerce Commission. The connection between the decrease of hazard, the danger to

life and limb, through the installation of safety appliances, by the substitution of steel for wooden cars, by double tracking, by increasing railroad facilities, as railroad business increases, appears to this Board to be direct and not indirect. The statistics submitted to this Board demonstrate that the number of trainmen killed on American railroads has grown smaller proportionately during the last few years while these safety appliances have been progressively installed; and in the Eastern District, the number of killed has decreased actually for the last few years down to 1909, which is as far as the separate figures extend. Since then the figures are not available for the Eastern District by itself.

The percentage of injuries has increased slightly pro rata to the number of men employed during the last two or three years; but the average is not greater than it has been in several years of the previous decade. As has been already pointed out, every period of specially active business is marked by an increase of casualties, due apparently to the employment by the railroads, at such times, of large numbers of unskilled men. Every panic is followed by a marked falling off in casualties, due presumably to the discharge of the less competent men. . . . New means of safety cost in the aggregate an immense sum of money. Any policy that would make it impossible for the railroads to command this sum of money would be a profound misfortune to the whole nation. Such a policy would be bad enough in its effect upon transportation, because it would reduce the efficiency of the railroads; but it would be criminal, in the sense that it would make the great army of railroad employees, who are numbered by hundreds of thousands, follow their hazardous occupation under conditions more hazardous than are necessary, and, indeed, more hazardous than are justifiable in a country like this.

*"Saving Clauses."*— . . . Among the articles submitted for arbitration are three, lettered "D," "P" and "Q," which are called by the men "saving clauses." The board has agreed that these articles should be accepted as having the significance which was conceded to them in earlier arbitrations. They have very greatly affected the action of this Board; for these articles make standardization within the district impossible unless it be standardization upward. It has not seemed reasonable to this Board, therefore, to remove low spots which were created by arbitration only three years ago, when it is not permitted, under the terms of these articles, to remove high spots.

The present proceeding has been in every sense of the word an arbitration. Many proceedings of the kind are, in effect, little more than formal compromises; but in this proceeding the intermediate arbitrators have been obliged to pass upon the merits of every article as proposed. The result is that, in most cases, each article as adopted has been adopted by a vote of four to two, although the majority represents at times the intermediate arbitrators and the representatives of the men, and at other times the intermediate arbitrators and the representatives of the railroads. . . .

The percentage of increase in pay granted in the passenger service is not large. The mileage rate for conductors is that requested by the men and is identical with the rate in the South, and the differential between conductors and brakemen is the same as there obtains.

The awarded rates of pay in local freight service while considerably less than those asked are the same as are now paid in the same service in the South for conductors, and also for brakemen.

In through freight service the rates asked for are again the Western rates. The rates awarded approximate but do not reach the Southern rates. If it had been possible to discriminate between fast freight and slow freight service the Board would have been disposed to place slow freight on the Southern basis.

In yard service, although the hours are long, the present rates of pay in first class yards in the East are already within 2½ per cent. of existing Chicago rates. The Board preserves the exist-

ing classification of yards in the East, and advances the pay in all classes of yards by 1 cent an hour, which places the first class yards in the East upon the present Chicago basis.

In regard to the proposition of the railroads that the justice of the wage scales existing in the West and in the South has not been proved, it must also be said that the justice of the wage scale prevailing in the East has not been proved.

Articles A, B, C.—Passenger conductors, minimum 155 miles, 2.9 cents a mile; ticket collectors 2.3, baggagemen 1.65, rear brakemen 1.6, other brakemen, same. On runs less than 155 miles a day, conductors \$4.50 a day; collectors \$3.57, baggagemen \$2.75, rear brakeman \$2.60, other brakemen \$2.55. On short runs, the minimum work day is 8 hours within 12 consecutive hours. Overtime after 8 hours work within 12 hours; layovers less than 1 hour not to be deducted. Overtime rates: Conductors 45 cents an hour, collectors 35.7, baggagemen 27.5, rear brakemen 26, other brakemen 25.5. Special provision is made for "other passenger trainmen," but what class this refers to is not stated. Regularly assigned passenger trainmen are entitled, subject to certain conditions, to the following minimum rates per month, exclusive of overtime: Conductors, \$135; baggagemen, \$82.50; rear brakemen, \$78; other brakemen, \$76.50.

Article D.—This forbids reductions in crews or increases in mileage to offset the increase now granted; but short turn-around runs may be rearranged to prevent excess mileage, provided no crews are taken off.

Article E.—This prescribes percentages for increasing the pay for special services not covered by the standard rates; for example passenger conductors, 8.2 per cent.; brakemen, 6.7 per cent.; local freight conductors, 13.2 per cent. (eight different percentages). The award of 1910 is confirmed in certain minor particulars.

Article F.—Through and irregular freight, minimum 100 miles, either straightway or turn around; conductors, 4 cents a mile; rear brakeman, 2.67; other brakemen, same.

Article G.—Way freight, etc., conductors, \$4.50; rear brakeman, \$3.00; other brakemen, same.

Article H.—This was a separate demand for work trains, wreck trains, etc. It is covered by article F (through freight service).

Article I.—In all road service except passenger, 100 miles or 10 hours is the minimum day. Crews may be assigned to short runs, but not after having been on duty 10 hours.

Article J.—Milk trains, helpers, etc.; covered by Article E.

Article K.—Regular way freight and work train crews guaranteed 100 miles or 10 hours each working day, including holidays; but if an act of God makes service impossible the guarantee does not apply. Crews may be assigned to other service to complete the guarantee.

Article L.—Deadheading: existing schedules to remain unchanged.

Article M.—Provides for pay of freight men when held away from home more than 18 hours.

Article N.—This denies the demand for time and one-half where a train has more than one engine.

Article O.—Classification of yards remains unchanged: Pay increased 1 cent an hour, but not to make a rate exceeding the Chicago standard. Overtime pro rata (not time and one-half).

Article P.—A man's earnings shall not be diminished; but no man shall secure an increase by combining old rates with new conditions, or new rates with old conditions. Demands under this article must be properly formulated by the brotherhood committees acting jointly; and must be uniform for each set of runs.

This and certain other matters may be referred back to the arbitrators if no agreement can be reached.

Article Q.—No existing agreements are changed except as specifically stated.

DISSENTING OPINIONS.

Both of the minority reports testify to the fairmindedness of the neutral arbitrators. Messrs. Atterbury and Smith declare that standardization is chimerical and uneconomic; that the increase in cost of living does not justify the 7 per cent. granted; that increased responsibility "an intangible thing" has not been proved; that the six millions means the interest on 120 millions, which capital is sorely needed for improvements imperatively demanded for the safety of the public; that, because of the full-crew laws, the burden is not six but ten millions; that this new burden makes it harder to deal equitably with other [non-union] classes of employees; that this decision will bring on new demands, strike votes, public anxiety, mediation, arbitration and compromise. The endless chain will continue. It is agreed that some government body should study wages.

Messrs. Sheppard and Cease complain that wages in other territories were not sufficiently considered; that pay-and-half for overtime and for double heading are two "great principles," founded in justice, as train delays are not due to the fault of the men; that injustice was done by not going back of 1910; that Articles D and P were not intended to be submitted to arbitration; and that the decision on yard rates has been unduly influenced by rates in the South, which are affected by racial competition.

WHAT A LOCOMOTIVE BURNS.—The problem which confronts the railway officer in considering this subject is an extensive one. To obtain from the modern locomotives the average power required from them it is necessary to consume fuel at the rate of about 100 lbs. of coal per square foot of grate per hour, and to obtain the maximum power required it is necessary to consume 150 lbs., and at times in excess of this amount, per square foot of grate per hour. That is, to obtain the power necessary to perform the work demanded, a boiler which from its heating surface would be rated at about 320 h. p. is frequently forced to develop over 1,500 boiler horse power, and our records show that another boiler which would on the basis of heating surface be rated at about 400 h. p., has developed as high as 1,994 boiler horse power. The performance stated above requires coal consumption at the rate of from 6,000 to 10,000 lbs. of coal per hour, and this has been done on a grate of 55 square feet.—D. F. Crawford before the International Society for the Prevention of Smoke.

ENLARGING STATION AT MELBOURNE, AUSTRALIA.—Owing to the remarkable expansion in the Melbourne suburban passenger traffic the accommodation at Spencer street station is becoming congested and it will become worse as the population increases. Extensions and improvements have been effected, but there is a general desire to see the old building demolished and a new building, designed to meet the demands of modern traffic, substituted. The idea of the commissioners in carrying out further additions and alterations is not received with satisfaction since, however much the new improvements may fit in to assist the urgent demands for space, the design and layout of the old structure have traffic drawbacks which militate against permanent usefulness. Architecturally, too, the station is gradually drifting into a sort of patchwork job, and is unsightly as compared with other city structures. It is now proposed to convert the No. 10 country platform into a double-faced platform, so that two trains might be prepared for despatch at the one time. The No. 9 (old Essendon) platform is to be extended to a total length of 800 ft., so as to provide additional accommodation. New ticket offices, with provision for 12 windows, are also to be erected. It is stated that the extension of the station will enable three trains for the Northeast being docked at the one time, thereby removing the present inconvenience. Under the proposed conditions passengers will be able to board trains as soon as they reach the station. It is anticipated that the alterations will be completed in time to meet the Christmas traffic.

## W. C. NIXON AND THE FRISCO.

W. C. Nixon, formerly vice-president in charge of operation and maintenance and recently receiver and chief operating officer of the St. Louis & San Francisco, was elected president at the annual meeting of the stockholders on November 10.

The election of Mr. Nixon shows that those now dominant in the affairs of the Frisco accept the view expressed in this paper when the road went into the hands of a receiver, namely, that its troubles are due to financial and not to operating causes. The Frisco is heavily bonded relatively to the density of its traffic and the amount of its earnings. Furthermore, in acquiring control of the Chicago & Eastern Illinois and of the lines running from New Orleans to Brownsville it assumed additional heavy burdens. Only the skillful handling of the property by the officers in charge of its operation enabled it to carry as long as it did the loads piled on it by those responsible for its financial management. The election of Mr. Nixon as president of the company is a partial reward for his efficient and economical handling of the operating department, as vice-president and subsequently as chief operating officer under the receivership. It does not seem unsafe to assume, in view of recent developments, that after the receivership is ended, he will be continued as president.

It is very questionable whether it will prove to be expedient for the road to pass out of the hands of the receivers without a substantial scaling down of its funded debt. If all of its obligations other than those of the Frisco proper are got rid of its capital will still, we believe, consist of only about \$21,000,000 of preferred stock and \$29,000,000 of common, as compared with about \$210,000,000 of funded debt. On this basis its funded debt per mile will be in excess of \$41,000, which is altogether too much to ask any road earning only a little more than \$8,000 a mile gross to carry. Under these conditions fixed charges are bound to be so great as to interfere with adequate expenditures for maintenance and improvements, and as long as adequate expenditures cannot be made for these purposes, the property cannot be operated with satisfactory efficiency and economy.

However, whether the fixed charges are to be scaled down as they ought to be or not, there could hardly be found any man better fitted to deal with the Frisco's problem than Mr. Nixon. He has ability, energy, perseverance and patience—all of them qualities that are indispensable to the successful handling of a property like the Frisco. He is a practical railway man in the truest sense of the word, having risen from the ranks through all the grades of the operating department; and at the same time he avails himself of all the new methods, statistical and otherwise, that have been developed in recent years to promote efficiency. He fully appreciates the economies to be effected by increasing the train load and has used them so effectively that between 1906, when he went to the Frisco, and 1912 the revenue

trainload was increased from 214.5 tons to 255.2 tons, and the total trainload from 242.2 to 298.1 tons, in spite of the fact that the road did not have sufficient money with which extensively to reduce grades, and buy more powerful locomotives. At the same time, Mr. Nixon has shown the keenest appreciation of the advantages to be gained by economies in little things.

While seeking to save the road money by the use of economical methods, he has co-operated vigorously with the traffic department in trying to increase earnings by giving good service. The new system of handling loss and damage claims and the new method of handling merchandise which have been adopted have been described from time to time in these columns. With Mr. Nixon in charge the operation of the Frisco will be in good hands. It is to be hoped, however, that the financial management of the property will prove to be in equally good hands, and that this will be shown by a readjustment of its finances which will give those directly charged with its operation a real opportunity not to only operate it successfully, but also to develop it along the right lines.

Mr. Nixon was born in February, 1858, in Illinois, and entered railway service at the age of 20, in 1878, with the Burlington & Missouri Railroad in Nebraska. After nine months with this road he became connected with the Atchison, Topeka & Santa Fe, and was consecutively watchman, clerk, cashier, agent, chief clerk in the superintendent's office, trainmaster, material agent, division superintendent, and to July, 1896, superintendent of terminals at Chicago. From July, 1896, to January, 1897, he was general agent of the freight department, and from 1897 to January, 1900, superintendent of the Chicago division of the same road. He was then for two years general superintendent of the Gulf, Colorado & Santa Fe; from January, 1902, to June, 1904, general manager, and from June, 1904, to August 1, 1906, second vice-president and general manager of the same road. On August 1, 1906, he left the Santa Fe to become vice-president and general manager of the St. Louis & San Francisco. In May,



W. C. Nixon.

1911, his title was changed to vice-president, in charge of maintenance and operation, which office he held until he was appointed chief operating officer, and later receiver during the present year.

**SIERRA LEONE RAILWAYS.**—The Sierra Leone Government Railways are in the unusual position amongst African Railways of having a 2 ft. 6 in. gage, which has been found perfectly capable of carrying the traffic offered. On the main line, which runs from the Port of Freetown to Pendembu, the maximum grade is 2 per cent. (compensated) and the sharpest curve is 17 deg. There is also a mountain railway from the Freetown terminus up the Lion Rock, a distance of six miles, which is worked by adhesion and has a general grade up the mountain of 3.33 per cent.

## OVERLOADING FREIGHT LOCOMOTIVES NOT ECONOMICAL.

By J. S. SHEAFE,  
Engineer of Tests, Illinois Central.

The rate of increase in railroad mileage has been so rapid that perhaps the time necessary for improving conditions to effect the most efficient handling of freight trains has not been available. Each operating day has brought its own great number of problems requiring immediate solutions. Emergency conditions have prevailed. Does the overloaded engine mean maximum efficiency?

In order to reduce the whole question to a percentage basis some figures are presented for consideration in the belief that they are correct. As city traffic increased, it became necessary to start the humane society, in order to save the horse. This indicates that the human tendency is to put on all the carrier will bear. It always has been, and always will be thus. As a general thing locomotives in this country are overloaded, and most of them are pooled. Both of these conditions mean expensive operation, and how expensive can only be known by those who are closely in touch with engine and train crews.

To begin with there is so much tonnage each month to be moved. The cheapest operating cost must lie somewhere between a locomotive struggling with an overload and a fair sized train making a quick run. Losses of time due to poor despatching cannot be overcome except by treating individual cases, as with any other man failure.

A freight locomotive is variously estimated as being worth from \$25 to \$100 a day; hence the assumption that it is worth \$50 a day is not unreasonable. As this locomotive spends approximately one month out of every twelve in the shop undergoing heavy repairs, and much more standing in roundhouses, in addition to other time losses, such as standing on sidings, the actual time used in hauling freight will be found to be rather a small percentage of the whole.

As an illustration, a certain locomotive, rated at 3,500 tons, requires, with good luck, 12 hours to make a district 120 miles long, with a coal consumption of 20 tons. Under favorable conditions, and with such an engine making 25 single trips per month,

$$25 \times 3,500 \text{ tons} = 87,500 \text{ tons moved.}$$

Assuming the engine to work 25 days a month, this will cost roughly:

Engine crew (\$9.15 x 25).....	\$228.75
Train crew (\$11.25 x 25).....	281.25
Coal (20 tons x \$2 x 25).....	1,000.00
Engine (\$50 x 30).....	1,500.00
Cost of repairs (3,000 miles x 12c.).....	360.00
Total .....	\$3,370.00

which means about \$38.50 per 1,000 tons hauled 120 miles. Reduced to an hourly basis it would be in service, 12 hours x 25 trips = 300 hours, and would haul at the rate of 292 tons per hour on the road.

Only 25 trips per month are possible, as the 12 hours running time is not always met. The overtime consumed will prevent over 25 trips being made. With conditions as above the 120 mile trip can be made with 3,000 tons in 8 hours and on 15 tons of coal. Tonnage has then been reduced 17 per cent., but running time has been reduced 33 per cent. and the coal required 25 per cent. In this case it is very evident that the engine can make more than 25 single trips per month. Allowing a 12 hour layover at each end of the district it can make 36 trips with a total time on the road of 8 hours x 36 trips = 288 hours to haul 36 x 3,000 tons = 108,000 tons. This amounts to 375 tons per hour on the road, an increase of 28.4 per cent. This will cost:

Engine crew (\$9.15 x 36 trips).....	\$329.40
Train crew (\$11.25 x 36 trips).....	405.00
Coal (15 tons x \$2 x 36 trips).....	1,080.00
Engine (\$50 x 30 days).....	1,500.00
Repairs (4,320 miles x 12c.).....	518.40
Total .....	\$3,832.80

which would mean approximately \$35.50 per 1,000 tons hauled 120 miles.

This comparison therefore shows a direct saving of \$3, or 8.5 per cent. in cost per 1,000 tons hauled 120 miles and an increase of 83 tons hauled per hour on the road, or 28.4 per cent. A direct saving also is the reduced cost per mile for engine repairs. This is demonstrated by the fact that passenger engines invariably cost less than freight engines, although kept up in better shape. The passenger engine is never loaded to such an extent that it cannot quickly "wheel" its train and carry it at a high rate of speed. This item would, therefore, further reduce the above cost of hauling 1,000 tons per 120 miles.

Extremely long trains, now common, increase the number of break-in-twos. This results from the fact that locomotive tractive effort has increased in a greater ratio than draft gear strength. It is a wonder that more drawbars are not pulled out.

Human nature is such that when things begin to go wrong interest in a perfect performance is lost, and in some cases, aggravated ones of course, wilful damage to equipment is administered, just as a man when he is angry will sometimes kick a dog when it gets in his path. In other words, interest and consequent energy are increased by the square with a smooth trip. Break-in-twos requiring the carrying of chains from the caboose for the length of 65 cars or so have a demoralizing effect. The effect on crews of a quick run is good. It means that they get the same money for a fraction of the time usually required.

In the cases under consideration, 87,500 tons are moved in the first one, as against 108,000 tons in the second. This is an increase of 20,500 tons or 23.4 per cent. in the amount of work done by the engine, and means that the work now requiring 27 engines would be done by 22.

There are many objections to be raised against the overloading of an engine but it is not necessary to dwell upon them. The terrific strain on every staybolt, bolt and part is evident always; the tearing of the fire with consequent flue leaks is expensive.

If the modern locomotive appliances increase economy and power why not apply them for the sake of better operation rather than for the purpose of putting more cars on the rip track? As the standard draft rigging today is too weak for the heavy demands put upon it, it would appear that operating efficiency can be increased more by lightening tonnage than by constantly adding to it.

Can there be any other item of economy in the hauling of maximum tonnage than a supposed saving of crew wages by managing to get an extra few hundred tons over the road? In the above cases it costs approximately \$20.40 in wages to get any sized train over the district, if no overtime is paid. Neglecting all other items of expense and considering the difference between 3,000 and 3,500 tons hauled, and in the same ratio, if the overtime amounts to \$3.33, or somewhat less than 2 hours, the wage cost is the same per 1,000 tons hauled. The hidden costs are many, however, both direct and indirect.

The loss in available cars, when needed most, will be found of importance. As a modern Mikado locomotive costs \$23,000, and is worth to a company \$50 per day, it would be expected that a box car costing about \$1,200 would be worth \$2.60 per day. As the average movement for box cars on the road in question was 21.06 miles per day (in 1912) it would require, with this mileage, over 47 days to go 1,000 miles. The C. L. rate being \$1.10 for this distance and a minimum of 20,000 lbs. being in the car, the amount earned would be \$220 or about \$4.60 per day if the car is carrying a load at all times, which it is not.

Slow movement is hard on the shipper alone if there are plenty of cars, but if business is diverted on account of a car famine the loss is felt by all concerned. If the running time can be cut down one-third (probably only possible by tonnage reduction), the car movement would be increased in this case from 21.06 to 27.84 miles per day. This means earnings of \$6 instead of

\$4.60 per day, for the time the car is hauling the minimum load. As the running time with 3,500 tons is 12 hours (best time), it should require 100 hours actual running time to make the 1,000 1,28 hours required (on basis of 21.06 miles per day), there is an miles exclusive of yard delays. With the time of 47 days, or apparent standing time of 1,028 hours. In other words, if the car travels 10 miles per hour, during the running time and on the above basis, it moves less than 9 per cent. of the time and stands waiting in yards over 91 per cent. of the time. This, of course, includes all loaded and empty cars in yard delays, storage, repair tracks, demurrage cars, etc. If it is figured in any other way, even to allowing the daily mileage of 36, as was reached by one railroad for a short time under favorable conditions, the difference between running and total time is startling.

As cause precedes effect some reason or reasons for such a condition must exist and be evident. It has been said of a certain western railroad that, during a blockade which had become chronic, one superintendent cleaned up his division by despatching lighter trains, thus increasing crew and locomotive efficiency. As caboose mileage will be found about three times that of a freight car it follows that yard delays come to the latter but not to the former. Extreme yard delays which are recognized generally as a most expensive condition and one which has been standard practice for many years is perhaps responsible for some of it.

Operating officers have for so many years been accustomed to increased tonnage that it has become a habit. It is custom, and custom is stronger than the law. Yard delays result from several causes, one of which is overloaded trains. Disregarding the added penalty on the road resulting from this, it can be seen that if an engine is rated at 3,500 tons out of a division terminal, 3,500 tons it must take or a lot of explaining follows. If 2,900 tons are ready at 6 p. m. and nothing in sight we have a case of 600 tons, or 17 per cent., causing an added delay to 2,900 tons, or 83 per cent. The 2,900 tons occupy considerable track room and if the yard is almost full conditions are aggravated. The only thing looked for is to have an extra 600 tons gotten over the division for the same wages as the 2,900 tons would cost. But it doesn't work out this way. The heavy train wants some overtime and a few drawbars and usually gets them.

If a train arrives during the night with full tonnage it gives over the necessary 600 tons and the remainder gets in line for

next out. Many times during the rush season a freight train stands on the main line or on the first available siding waiting for room to be made for it. If it was shorter the necessary space could be sooner obtained and on the other hand if the despatcher was not holding outgoing ready cars in order to "fill out," such delays would be practically eliminated.

Bad orders resulting from too heavy and too long trains which are brought in by chains or which are left in sidings, and which sometimes require the load to be transferred, cause both increased delay and expense and reduced average mileage. In considering bad orders sight is not lost of the number made each working hour in the yards and which cannot be attributed to excessive tonnage. However, a sufficient number of cars are damaged on the road to warrant an investigation into just what this extra "wage saving" costs.

Not long since an operating official quoted damage done in yards at not more than ten per cent. of the total. "Damage," not to be confused with failure, is rarely found in a train of manageable size.

There are many yards where trains are made up with the cars as they come. At other points heavy cars go next to the engine with flats and empties just ahead of the caboose. It is safe to say that if a train is improperly made up, i. e., with light and heavy cars mixed, time would be saved by switching the heavy loads ahead where they should be.

Car shortages could possibly be lessened if the "fill out" idea was somewhat modified.

### GAS-ELECTRIC LOCOMOTIVE.

The latest application of the idea of gas-electric propulsion the railway work is the 57-ton locomotive recently placed in service by the Minneapolis, St. Paul, Rochester & Dubuque Electric Traction Company, perhaps better known as the "Dan Patch" Line. This road has been operating a heavy passenger business from Minneapolis to Northfield, Minn., for several years entirely by gas-electric cars. The freight traffic and excursion passenger traffic had grown so heavy that it was felt a locomotive would be needed and consequently the gas-electric locomotive, shown in Fig. 1, was purchased. The locomotive was built at the Erie, Pa., works of the General Electric Com-



Fig. 1—Gas-Electric Locomotive for the Dan Patch Lines.

pany and was run under its own power from there to Minneapolis. Since being placed in service in July, it has been in constant service and has proved successful in every respect. Although the locomotive is rated at 38 m. p. h. it has attained a speed of 51 m. p. h., running light, and 45 m. p. h. with a 5 car train. This performance, however, is not to be recommended for regular schedules. The fuel consumption when using "motor spirits" has been found to be about one gallon for 95 ton miles.

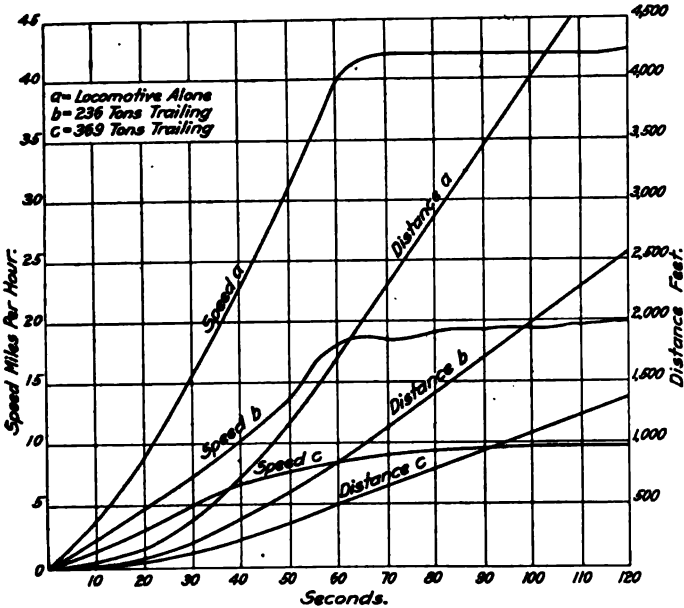

Fig. 2—Acceleration Tests of Gas-Electric Locomotive on a Level Tangent.

The results of three actual acceleration tests of the locomotive light and with train are given in Fig. 2. This diagram shows the speed attained and the distance covered at the end of various periods of time.

The power plant for the locomotive consists of two standard sets such as are used in gas-electric cars, run in parallel. Each of these sets consists of a 175/225 h. p. 8 cylinder V-type gasolene engine running at 550 r. p. m., direct connected to an 8-pole 600-volt interpole direct current generator. The control is so arranged that either one or both of the engines may be used in

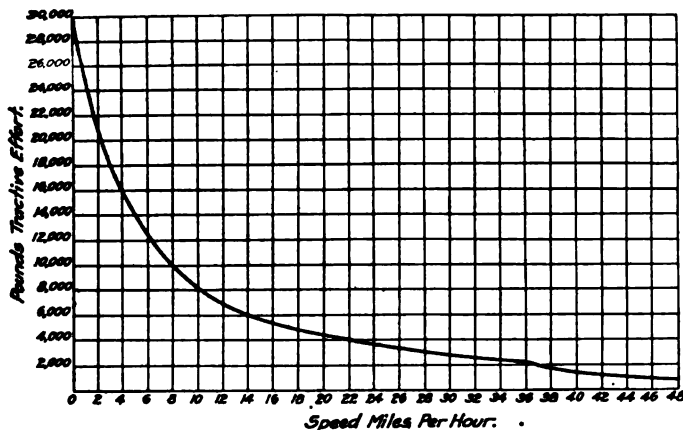

Fig. 3—Available Tractive Effort; 57-Ton Gas-Electric Locomotive.

the operation of the locomotive. There is no trouble about the load dividing equally between the two generators when both are in use, as the generator which tends to run at higher speed will tend to take a greater share of the load and will consequently slow down until it is running the same speed as the other unit. The power plants are started by air in the same way as on the gas-electric cars with the additional feature that after one set is

running the second may be started from the first electrically.

The control of the equipment is similar to the standard gas-electric car except that four motors are used instead of two. The motors are placed in pairs connected permanently in parallel and these pairs may be put in series or parallel. The controller provides seven points in the series position and six points in the parallel position. There are also two additional points for shunting the motor fields, thus making fifteen running points in all. The control of the engines is by manual operation of the throttle valves. Four 100 h. p. 600 volt interpole motors are used, being suspended directly from the axles and driving through a gear reduction of 3.41. The tractive effort obtainable at various speeds is given in Fig. 3.

The locomotive is equipped with a 5 k. w. 65 volt gasolene engine driven lighting set, which furnishes energy for train lighting, as well as headlights and cab lights. A 25 cu. ft. electrically driven air compressor is provided, which operates on the 65 volt lighting circuit and provides for pumping up the initial charge of air for starting the main engines. The main engines are each provided with 22½ cu. ft. air compressors. A coal fired hot water heater is provided in the cab for train heating or for keeping the engines warm during layovers in winter.

The principal features and dimensions are as follows:

Gage .....	4 ft. 8½ in.
Length, inside knuckles .....	36 ft. 4 in.
Extreme width .....	10 ft. 5¾ in.
Extreme height .....	14 ft. 6¾ in.
Length over cab .....	27 ft.
Length between truck centers .....	20 ft.
Total wheel base .....	26 ft. 10 in.
Rigid wheel base .....	6 ft. 10 in.
Minimum radius curve .....	100 ft.
Trucks .....	Swing bolster type
Wheels .....	M. C. B. rolled steel
Wheels, diameter .....	33 in.
Axles .....	6½ in.
Journals .....	5½ in. x 10 in.
Weight on drivers .....	114,000 lbs.
Total weight .....	114,000 lbs.
Cab .....	Steel box type, removable ends
Frame .....	Open hearth steel
Air brakes .....	G. E. straight and automatic type
Sanders .....	Air operated
Bell .....	Locomotive type with air ringer
Whistle .....	Air operated
Headlight .....	Incandescent type
Fuel tank capacity .....	300 gals.
Steps, pilots, draft rigging, grab irons, etc., conform to I. C. C. and M. C. B. practice.	

DEMURRAGE IN ENGLAND.—Following conferences with shippers and receivers of freight, the railways of England and Wales have modified their rules regulating the collection of demurrage on freight cars at private sidings. A car which is set to be loaded may be held two days, besides the day on which loading is begun, instead of one day, as heretofore; while the consignee is to have three days' free time, exclusive of the day of arrival, instead of two. On freight which is to be transferred to vessels at the seacoast, the allowances are still more liberal. The standard demurrage charge on these roads is one shilling, sixpence, per wagon per day.

RAILWAY CONSTRUCTION IN GERMAN SOUTHWEST AFRICA.—Though German Southwest Africa is the only German colony possessing a good and complete railway system, railway construction there is by no means at a standstill. It appears that there are three railway lines which are urgently needed in the colony. The first is a line into Amboland, which should do much towards the development of that territory; this project has already received the sanction of the Reichstag. Secondly, there is need for an extension of the Swakopmund-Windhuk line to Gobabis, about 62 miles from the Anglo-German frontier. The district through which it is proposed to run this extension is remarkable for its extreme fertility. Farmers who have already exploited this rich territory have failed previously, as they were unable to dispose of their produce owing to the lack of means of communication. The third line is to be an extension of the Lüderitzbucht railway to Keetmanshoop and to Hansuur, it will unite Lüderitzbucht with the railway system of the Union, South Africa.



## MR. MELLEN SPEAKS OUT.\*†

Practically all the turmoil that has surrounded every move made by the New Haven in the last ten years has been stirred up by Boston bankers who were desirous of controlling the New England trolley field. Of course, there developed additional opposition in the case of the Boston & Maine acquisition; many honest people fought our plans of expansion because they were honestly opposed to it. . . .

The New Haven, long before I took charge, had been in the trolley business. The electrical lines are natural feeders: I simply pursued the same policy of developing this feeding system; and in acquiring additional lines I stepped on the toes of the people who control the Boston elevated, the Massachusetts electric companies and the Boston & Worcester Street Railway. They fought us tooth and nail. They raised the cry of monopoly against the New Haven, although at the same time they were trying to monopolize the field for themselves.

The New Haven policy met with no opposition in Rhode Island or in Connecticut, or in Massachusetts, for that matter, outside of Boston and vicinity. The people in the districts where we bought the trolley lines made no opposition because they knew we were improving the service.

I worked to develop this policy of expansion because I believed in it. I believed that the elimination of duplicate managements and expenses of superintendents and the welding of all parts of the transportation system under one head was for the economic good of the community, and I still believe in that policy. Even the Massachusetts legislature confirmed all our purchases.

But at best I was simply the operating head of the road. The fight was between the banking interests; between New York on the one side and Boston on the other.

I had no more to do with the financial policy of the New Haven than I had to do with the editorial policy of the *Boston Post*. When the road needed money, it was supplied at times and in amounts by the banking house that dominated every move the New Haven made.

I will tell you of a little incident that happened a few years ago. I was traveling on the road one day when I happened to meet a representative of one of Boston's biggest banking houses. As a note issue was being contemplated by the New Haven, I talked with this man about the price of money and what rate of interest we should probably have to pay on the notes.

A day or two later I was hauled up on the carpet by representatives of our fiscal agency and told in effect to mind my own business. When the New Haven wants money, we will furnish it, they said, and we don't need advice.

Representatives of our fiscal agents made the necessary arrangements. My position was to be filled by Mr. Elliott. I knew this in February from friends in St. Paul. My own crowd was working behind my back.

While I was the operating head, the house of Morgan absolutely dominated the New Haven policies. J. P. Morgan is dead, but control is just as absolutely theirs today, and the second generation is working hand in glove with the Boston Machiavelli.

I came to New Haven not for the salary that was attached

to the job or any perquisites that might accrue to me as president of the road. I came because New England was my home and because I had seven children whom I wished to educate here in the East. Personally I have asked no one about my salary for over twenty-five years. I took what they gave me.

I believe that the paying of tremendous salaries to corporation officials is a waste of money. I believe that no man in the country is worth more than \$25,000 a year. And I know that I would work fully as hard for the New Haven Railroad for \$25,000 as I did for \$60,000 or \$75,000. This matter of large salaries will probably soon come before the Interstate Commerce Commission, and before many years the commission will be given the power to veto exorbitant salaries. Of course any man is human enough to take all the salary that is given him. But that does not alter the fact that he cannot earn for any corporation more than \$25,000 a year.

We bought the Boston & Maine purely as a feeder to the New Haven. The purchase has been approved by the Massachusetts legislature. Now that I am out of the game and have no axe to grind, I still maintain that the purchase of the Boston & Maine was made in good faith and was done for the economic good of New England.

No receivership, in my judgment, is necessary for the Boston & Maine.

In regard to the steamship end of the system, they are such an integral part of the service that it is impossible to say how profitable they would be if operated separately. If my advice had been followed we would have sold those steamship lines five years before the government ordered us to sell out.

When Morse offered the New Haven \$20,000,000 for the steamship lines, I advocated their sale. But the directors voted to hold them. Even at that time I pointed out that some day the government would compel us to sell them. Mr. Morse's offer of \$20,000,000 was for the stock of the New England Navigation Company, which cost us less than \$6,000,000. More than 50 per cent. of the business carried by the steamships is given directly by the railroads.

But aside from the mere question of policy I never cared to have the steamship lines on our hands. I was always terribly afraid that some day a fearful accident would take place on one of the Sound liners.

The New York, Westchester & Boston was purchased just prior to the panic of 1907. It has always been a source of keen regret to me that the company went into this enterprise, because there were so many ways in which the money could have been used in the development of the New Haven system to so much greater advantage. If I had had that money without the Westchester I could have four-tracked the road from Boston to Providence, could have taken out curvature and revised alignment, which would have saved us five miles between Providence and New London, and I could have electrified the entire New Haven road between New York and Boston.

The railroads will all go under government ownership. It is coming quickly. Five years ago I felt that I should not live to see it. But now I think that I shall. Regulation by the government during the last ten years has tended to lower the value of railroad stocks as investments. There is not the big money in railroads that there used to be. There will not be any opposition to government ownership when the time arrives, because private capital will find the field unprofitable as a result of the too strict regulation.

Under government ownership trains will still be late, wrecks will occur and mails will be missed and lost, in just as large proportion as they are today.

I am honestly of the opinion that there is no more safety in steel cars than in wooden ones. The only advantage in the steel car is that there is less danger from fire after an accident, and for that one reason it might be better to use steel cars.

\*Extracts from an interview in the *Boston Post*, November 9. Copyright, 1913, by the Boston Post Publishing Company.

†Mr. Mellen's interview was followed in the next day's papers by brief interviews with some of the men who had been criticised. William A. Gaston, president of the National Shawmut Bank and identified with Morgan interests in Boston, took exception to the statement about Boston bankers. Charles A. Stone, of the Banking house of Stone & Webster, denied responsibility for any of the turmoil. George von L. Meyer, chairman of the stockholders' protective committee, denied Mr. Mellen's assertion that the committee was "a marionette" and that it was formed at the behest of the New Haven's fiscal agent. Mr. Elliott said that it was not until July that he was invited to take the New Haven presidency. A member of the firm of J. P. Morgan & Company, quoted in the *New York Times*, denied that there had been any strife between New York and Boston bankers.

# MOVEMENT OF PRICES AND RAILWAY RATES.\*

Upward Trend of Former Compels Increases in Latter All Over World; France and United States Slow to Recognize Situation.

By M. CLEMENT COLSON,

Counsellor of State of France, formerly Director of Railways in the French Ministry of Public Works, Professor of Political Economy in the Ecole Nationale des Ponts et Chaussées of Paris, etc.

Among the economic phenomena which have characterized the last few years, few have been more marked than the general increase in prices. This increase at first influenced the railway situation only by the increase which it brought about in railway expenses. It is now commencing to bring about rate increases on a fairly large number of railway systems. In view of the rapid and continuous decline in transportation rates which has been one of the principal factors of economic progress for a century, this fact certainly merits attention.

When price variations are spoken of by the public at large, comment nearly always centers around changes brought about through retail sales. Economists who endeavor to measure these variations with exactness generally take for the purpose the average prices of the principal agricultural or industrial products as registered upon the exchanges where they are sold in bulk. These averages they call *index numbers*. In most cases they are interested only in transactions involving material goods, which constitute, however, perhaps only fifty per cent. of all current transactions. The prices taken into account by them do not as a matter of fact cover either wages or rents or transportation rates. To get an exact idea of what a given sum of money represents at different periods, it would be necessary to take account of both wholesale and retail prices of a number of products, such as services rendered by different categories of labor, by landlords who lease their property, by transportation agencies, etc. This would be a considerable task and one which, we believe, has never been attempted as a whole.

Yet studies made with respect to each price category taken by itself, according as they measure the general movement, permit at least an appreciation of its significance and importance. To be sure, this movement is not manifested to the same degree in different kinds of transactions, or in different countries whose markets are separated by more or less obstructive customs barriers. A generally characteristic gait is, however, maintained.

Disregarding oscillations resulting from alternating periods of prosperity and depression, there was till recently a general and rapid decline in the prices of industrial products, resulting from technical progress. Agricultural products, on the other hand, increased constantly in price in Western Europe until about 1875-1880, as a result of increasing density of population within a limited area. But about this time the tremendous decline in transportation rates that resulted from extensions of railways and steamship lines permitted older settled regions to draw a portion of their necessary subsistence from scarcely settled territory in the new world; the rapid fall in agricultural prices which took place toward the end of the nineteenth century resulted in an agricultural crisis. Both the increase of population in the new world and in the old, and the increase in consumption due to increased wages, have brought about a new movement of rising prices during the past fifteen years.

## THE INCREASES IN WAGES.

Wages, on the other hand, have constantly increased. The increase, rather slow up to 1850, was extremely rapid both in agriculture and in industry between that date and the agricultural crisis. It slackened considerably in the country districts, and to a slight extent in the industrial centers, thirty years ago. During the past fifteen years, however, it has resumed an accelerated progress, first in the towns, then in the rural districts. One may

sum up the change in living conditions of laborers during two intervals, thirty years apart, by following a study of the French Statistical Office prepared with the care and acumen characteristic of all the labors of its director, M. Lucien March. The results of this study are shown by the following relative figures (calculated by assuming the corresponding figures of the year 1900 as equivalent to 100) :

	1850.	1880.	1910.
Wages .....	51	82	110
Cost of living (uniform throughout)...	85.5	110	104
Purchasing power of wages .....	59.5	74.5	106

It should be remarked in passing that the advance in wages produced solely by the play of economic forces, notably technical progress and the accumulation of capital, was more rapid from 1850 to 1880 than from 1880 to 1910. Statistics confirm what a study of the mechanism of prices teaches, contrary to almost universal opinion, that the organized labor movement (infinitely more powerful in the second of the thirty-year periods considered above) is powerless to accelerate the advance in wages. We even believe that in France it had the reverse effect during the last few years, by disseminating ideas among the working classes that have considerably reduced the labor output. The result is that the net cost to the employer of a given piece of work has increased in recent years to a much greater extent than is indicated by statistics of increases in hourly or daily wages. This net cost would no doubt be less, the cost of living would also be less, the gain to the workman would be considerably increased, and his purchasing power would be very much greater, if the slackening of endeavor which has so much diminished the productivity of his work were less accentuated. As a matter of fact, in view of the attitude of labor, the peculiar mental influence of the labor unions is felt principally with regard to the productivity of labor, while wages depending on supply and demand escape their action whenever advances are sought which the state of the market at the moment does not justify.

In the cities rents also have notably increased. It is true that the cost of local transportation has considerably decreased at the same time that the cost of long distance travel has been decreasing, and also, except very recently, the cost of freight transportation.

The foregoing conclusions are based upon French statistics, but with very slight differences as to dates and as to the sweep of the movement, the general trend is the same for all Europe, and even today for America. It can be summed up by saying that the level of prices, including wages, presents a marked rise during the past century. Moreover this general movement, after having undergone a considerable slackening in the last quarter of the nineteenth century, and especially from 1882 to 1897, has been notably emphasized since then. Especially true of this latter period is the fact that the increase has become almost universal in character. Technical progress may continue to reduce the net cost of many industrial and agricultural products, but the margin is no longer large enough to neutralize either the increased cost and efficiency of manual labor or the increased demand due to the improved condition of the working classes.

We shall not inquire here into the causes of this general rise in prices. It may be remarked, however, that if the increase or decrease in the relative value of products or of different services results necessarily from causes which are peculiar to each, a movement which bears at the same time on practically all prices can hardly be explained except as the result of monetary causes.

\*Translated from the *Revue Politique et Parlementaire*, of August 10, 1913, by Bureau of Railway Economics, Washington, D. C.

The more so that these causes at the present time are obvious. The increase in production of gold, added to the development of methods of payment without the use of money (notes, checks, bank transfers, etc.), appears for a long time to have proceeded faster than that of the need for money. Although very much increased by the working of the Siberian deposits, the production of gold did not average 200 millions of francs (\$38,000,000) annually from 1840 to 1850. Carried by the exploitation of California and Australia to an annual average of 673 millions (\$127,870,000) between 1851 and 1870, the average fell back to 572 millions (\$108,680,000) between 1871 and 1890, but since that time the Transvaal mines have increased it to such an extent that it reached 1,089 millions (\$217,000,000) between 1891 and 1900, 1,959 millions (\$372,210,000) between 1901 and 1910, and finally amounted to 2,423 millions (\$460,370,000) for the year 1911. An equal increase in instruments of exchange must necessarily have resulted in a diminution of the purchasing power of money, that is, an increase of general prices.

If the production of gold continues to increase, there is no reason to doubt that our descendants will assist at a phenomenon analogous to that general increase during the sixteenth century which was the consequence of the enormous influx of precious metals resulting from the discovery of America, and which raised prices threefold according to some writers, and fivefold according to others. The existence at the present time of a larger stock of gold than four centuries ago, the colossal development of business transactions, the demonetization of silver and the diffusion of gold in the far East, serve actually to reduce the importance of the movement today, and without doubt will continue to do so in the near future. Its effects are none the less already felt and may be even more strongly felt in the future.

#### RAILWAY RATES LONG AN EXCEPTION TO THE RULE.

But there exists one industry, the railway industry, whose selling prices do not by the sole interplay of supply and demand follow the general rising movement under which it pays increased prices for all the things which it buys, notably the wages of its employees. Railway service is a public service which practically can be organized only by the state, or by grantees selected for the purpose. Railway operation has the character of a monopoly, and when a country endeavors to establish competition the only result is to divide the benefits of the monopoly between several enterprises. As a result, transportation rates cannot be left to free action; they must result from tariffs established by the government or under its control. Even in Anglo-Saxon countries the state, which has proceeded upon a wholly different conception, does not now allow the railways the same freedom of action accorded to them at the beginning, a freedom which has resulted in a control always arbitrary in character, although not as with us contractually defined.

Under these conditions an increase in rates, even when it is imposed by economic circumstances, always has the appearance of a unilateral and forcible act. This act is the more ill-received by public opinion the more it has become accustomed to seeing tariffs go almost constantly down in a movement which technical progress and the elasticity of traffic have rendered nearly universal. States have only rarely authorized increased tariffs on railways under their control, and when they have substituted government operation for operation under concession, they have generally sought to render the new régime popular by rate reductions. Both in England, where the railways desired to compensate themselves, by means of lessening former reductions which had become obsolete at certain points, for the new reductions imposed upon them at other points to diminish rate inequalities, and in the United States, where the cordial relations eventually established between different railway systems permitted the suppression of abnormal reductions brought about by previous competition over certain routes, laws have intervened to give quasi-judicial authorities power to oppose such increases. The freedom of action of the railway companies and the mobility of their tariffs, which has so powerfully contributed to the economic

development of the American continent by facilitating rapid railway growth, are no longer tolerated in the United States, since the need for new railways is less vividly felt than the need of equality in the treatment accorded competing producers. Increases in rates, always more rare than decreases, have for a long time been extremely exceptional almost everywhere, and have become rare even in America during later years.

But rapid increases in operating and construction expenses have come seriously to modify the situation in a number of countries. It was at the very crisis which followed the height of prosperity in 1906 and 1907 that the effect of this increase was most severely felt. As we have frequently stated in these pages, the movement of expenses always follows that of receipts, but at a slower gait; traffic progresses by spurts, the most recent of which have been somewhat in advance of the date set for them under the periodical alternation at approximately ten-year intervals of industrial prosperity and depression. At the beginning of these spurts the railroads meet the situation as best they can with the facilities at hand, and it is only when they have ascertained where, for what classes of traffic, and under what conditions the needs exist that they undertake the necessary and costly improvements of their operating facilities. Then, when the slackening of traffic renders it more difficult to provide for the new expenses, they endeavor to retrench. This is what occurred in all countries when the crisis of 1907-1908 seriously affected the financial status of most of the railway systems. But the results of the measures adopted to realize economies were nullified, when business again became active after a short period of slackening, by the general increase in prices. This increase is no doubt in part temporary with regard to coal and metals, but will probably be permanent with regard to wages; and the expenses brought about by the increase have been aggravated by the necessity of offsetting reduction in labor output by means of added facilities. It was under these conditions that the idea of raising rates gained ground and has been applied in a number of countries.

#### RECENT INCREASES IN RAILWAY RATES.

It has not been necessary to refer to Germany where, as we have frequently shown in these pages, abundance of traffic, added to exceptionally advantageous conditions resulting from the configuration of the country and from regulations very favorable to the railways, assured excellent results even with a relatively expensive system of operation. After the enormous falling off in net revenue in 1908, a serious effort was made to reduce expenses; since then the recovery of traffic has been sufficiently strong to secure for the capital invested a greater return in 1911 than the maximum realized in 1906, although capital had grown three and one-half billions (\$95,000,000) in the interval. Meanwhile, in the smaller German states, where the railways are less prosperous than in Prussia, the question of raising rates has been agitated at different times. Württemberg, soon after the unification of tariffs throughout the Empire in 1907, increased the price of fourth-class tickets in 1909 from 2.5 centimes to 2.875 centimes per kilometer (or from .765 cent to .88 cent per mile). The Prussian government withdrew the export tariffs on coal, but this was apparently less to augment receipts from coal traffic than to reserve that commodity for national industry. With regard to internal traffic the government contented itself with forcing the public to pay for the routing of freight shipments over longer but less congested lines. As to the stamp tax on bills of lading and passenger tickets which, established by the Empire, was levied for passengers at a progressively higher rate according to class of accommodation, this caused much disappointment since passengers simply shifted to the lower classes, and the measure has had the character of a general tax rather than an increase in rates, so that the railway administration of the several German states has suffered rather than profited by it.

In England successive interventions by the government at the time of the threatened strikes of 1907, and afterwards at the time of the strike of 1911, caused the companies to make con-

cessions to their employees in consideration of the promise that legal facilities would be afforded them for two classes of relief measures: first, the consummation of agreements or consolidations that would permit reductions in expenses by suppressing existing competition on many lines, not as to prices (in this respect there has been an understanding for a long time among the railways), but as to the facilities offered to the public. Second, increases in freight rates. A bill presented in 1912 which covered these two points, and at the same time imposed various new obligations upon the railway companies, did not pass. The government, called upon to fulfill its part of the agreement, at last carried a bill through both Chambers which consisted merely of a brief amendment to the Act of 1894, by virtue of which the Railway and Canal Commission was empowered to oppose all unjustifiable increases of freight rates. This amendment, which took effect in March, 1913, declared that an increase would be deemed justifiable when it should be established that its object was to meet the additional expense of handling goods resulting from increases in wages and improvements in working conditions since August 19, 1911 (date of the strike).

Already, in January, 1912, the railways had put into effect certain increases in passenger rates, to which the restrictive measures of 1894 did not apply; these very moderate increases affected only certain exceptional passenger tariffs. Utilizing the new privilege granted them in regard to freight rates, they put into effect on July 1, 1913, increases equivalent to a general surcharge of four per cent. on all traffic. It is natural that the customers of an industry thus suffer the consequences of its increased net cost; this is only what occurs in all unregulated industries, whether the increase results from the intervention of public authority, so frequent nowadays in the matter of labor, or whether it proceeds from natural price variations. So far as the railways are concerned the British government has kept its promise by refraining from interposing legal obstacles which would have rendered them victims of the pressure brought upon them on behalf of their employees. As to the agreements between different railways for the purpose of reducing expenses, the indefiniteness of the law has allowed them in most cases to consummate these agreements without the necessity of new legislation.

In Italy, as in England, betterments of the conditions of the laboring force have necessitated increases in rates. The old leasing system, which was ended in 1905, did not sufficiently permit the railways to provide the means for necessary increases in equipment and thus made it impossible for them to respond to traffic needs. Direct operation by the government, under the capable and energetic management of M. Bianchi, and a fairly independent administration, has notably improved the service. But expenses have gone up considerably, for the most part as the result of legislation enacted by Parliament, under pressure from railway employees, providing for increased rates of pay. The latest of such laws, enacted April 13, 1911, provided that part of the new charges should be taken care of by means of an increase in the price of term tickets and of special tickets issued at unusually low rates. These increases have produced six millions (\$1,140,000), perhaps a little over three per cent. of total passenger receipts. At the same time there has been authorized an increase in accessory charges on freight amounting in the aggregate to three millions (\$570,000), perhaps a little over one per cent. of the receipts from ordinary freight. This increase has for its object the creation of a reserve of 4,000 cars for the transportation of agricultural products.

In Switzerland a law passed June 23, 1910, improved the conditions of railway labor to a very marked degree; its application will add about fourteen millions (\$1,660,000) to a wage aggregate amounting to sixty millions (\$11,400,000) in 1910. Inasmuch as the wage increases provided for are often automatic, it is fair to ask whether the service will be improved along with the condition of the employees. On the other hand, the government railway administration has put into effect increases running from nine to twelve and a half per cent. on certain forms of sea-

son tickets very much used in that country. Other increases have been proposed, applying to round-trip tickets, but these the Federal government has not ventured to adopt.

In Belgium the state has for several years been endeavoring to offset the increase in expenses, brought about through increases in railway wages, by increases in rates. The stamp tax, which in France is but ten centimes (1.9 cents), has been raised from twenty to fifty centimes (3.8 cents to 9.5 cents). Measures have been taken to prevent such combining of shipments as permit the economical transportation of small consignments. Finally, after a long series of struggles and one first ineffectual attempt, increases of fifty centimes (9.5 cents) per ton have been imposed upon short-haul shipments of all coals.

In Denmark the net revenue of the state system declined from 6,300 francs per kilometer in 1905-1906 (\$1,927 per mile) to less than 2,100 francs (\$399) in 1909-1910, the gross revenue being more than 31,000 francs (\$5,890) per kilometer. The public authorities took steps toward putting into effect, on the first of December, 1911, new tariffs which would increase total revenues about 9 per cent.

In Russia ordinary freight rates on a large number of manufactured products were considerably raised in 1910. Some increases were also made with respect to passenger rates. But on account of the poverty of the population, these latter increases brought about a reduction of passenger traffic and a shifting from higher to lower classes which has forced a partial abandonment of the scheme.

It is especially in Austria and in Hungary that a considerable sustained effort has been made. In Austria the state system, considerably enlarged by the policy of purchase of railway lines which has led to the gradual disappearance of all the private systems, with the sole exception of the Südbahn, has been far from earning the interest on its capital. For a long time the government has been seeking to increase revenues by means of rate increases. Some years ago station charges had been considerably increased. A general reform was instituted in 1910, applying both to freight and passenger tariffs, by means of which revenues were increased ten millions (\$1,500,000 the first year and thirty-seven millions (\$7,030,000) in later years. But the results were seriously disappointing, and in 1911 and 1912 new and important increases were effected bearing partly upon certain special classes of goods (cement, lumber, alcohol, petroleum, coal, sugar) and partly on merchandise of all classes in carload lots.

In Hungary still more radical measures were adopted. In 1909 the net revenue of the state system was forty-five millions (\$8,350,000) less than the capital charges. During 1910 and 1911 rates on a majority of commodities were sensibly increased. The results, though satisfactory, remained still insufficient, and on March 1, 1912, normal fast freight rates were uniformly raised 7 per cent., exceptional fast freight rates 5 per cent., and all ordinary freight rates also 5 per cent. Finally, the celebrated zone tariffs for passengers, which had formerly been extolled as a great step forward, were completely abandoned.

This zone system, established in 1889, was destined in part to develop local passenger traffic and in part to bring the capital of Budapest and the farthest parts of the Kingdom into closer relations. At the beginning there were two zones for local passenger traffic, and twelve zones for journeys of from 25 to 225 kilometers (15.5 miles to 139.5 miles, each carrying a uniform rate for all the points within a fairly wide area, the rates increasing at successive steps either of 15 or 25 kilometers, 9.3 miles or 15.5 miles). Finally, there was a single zone, with a uniform fare, for all journeys over 225 kilometers (139 miles), even up to 800 kilometers (496 miles). However, there was a necessary break in all journeys by way of Budapest. This tariff produced a species of traffic, not then existent, over very short and very long distances. From 1888 to 1894 the state railways and the Austro-

Hungarian company's lines purchased by the state in 1891 increased their traffic in the following proportions:

	Per cent. of increase in	
	Number of passengers.	Passenger receipts.
Local zones .....	650	232
Zones 2 to 12.....	40	10
Zones 13 to 15.....	246	186

But when the long-distance travel, hardly existent before, had developed so seriously as this, it did not take long to ascertain that the receipts from such travel did not cover the corresponding expenses. In 1896 and 1903 the local tariff was altered and two new zones created, one of 75 (46.5 miles) and one of 100 kilometers (62 miles), so as to establish a complete uniformity of rates only beyond 400 kilometers (248 miles). Experience shows that these increases have had no effect on the growth of traffic.

Under these conditions passenger traffic barely made expenses, but did not contribute, so to speak, to net revenue. On the first of July, 1912, the zone system of tariffs was abolished. Rates are now (with a few exceptions) increased at five-kilometer intervals for trips under 30 kilometers, and at ten-kilometer intervals thereafter, the per-kilometer rate rapidly decreasing above 250 kilometers. The increased revenues resulting from this new classification amount to about sixteen million francs (\$3,050,000), or about 18 per cent. of former passenger receipts.

#### THE SITUATION IN FRANCE.

It is clear that the once generally accepted idea, that railway rates must always continue to decline, is contrary to the facts. In France public opinion still refuses to admit that rates can ever be increased. However, the operating results which we analyze each year lead us to fear that, as in so many other countries, we shall be obliged to apply higher rates some day. From 1906 to 1912 the revenues of the railways (*d'intérêt général*) increased in round numbers about 350 millions (\$66,500,000), while operating expenses increased 400 millions (\$76,000,000), and the capital invested had increased about two billions (\$380,000,000). Of this increase in expenses, the follies that have accompanied the purchase by the state of the Western Railway are perhaps responsible for fifty millions (\$9,500,000), adding that much to the normal increase in expenses which the government-operated systems must suffer, as well as the private systems. Even after deducting these fifty millions (\$9,500,000), it is clear that the increase in expenses entirely absorbed the total increase of revenue. The operating ratio in 1906 was about 52 per cent. The length of the new and slightly productive lines put into operation in the interval, upon which this ratio is necessarily higher than on the older lines of dense traffic, is hardly more than 1,000 kilometers (620 miles). On the other hand, the additional traffic of the older lines would not by a wide margin have brought an increase in expenses proportionate to that of revenues, had not the net cost of transportation grown. On the whole, an increase in expenses equivalent to half the increase in revenues would have been the expected thing had not the conditions of operation been seriously changed.

Among the changes of this period are those which represent real improvements, both as to the speed and the number of trains, improved car accommodations, etc. But the expenditures undertaken by the railway managements on this score have not greatly exceeded the economies brought about through technical progress; the use of more powerful locomotives, permitting an increase in average train load, the development of classifications based upon weight, etc. The enormous gap between the results actually attained and those reasonably expected from the development of traffic is due chiefly to the general increase of prices and especially of wages.

But the intervention of public authority has considerably contributed to the increase. We have often spoken of the

special legislation which assures railway employees better pensions even than those granted to state employees themselves, and incomparably better than those provided under ordinary legislation for workmen in general, without even that contribution from the budget which is granted to other workers. This special act increased expenses of operation from twenty-five (\$4,750,000) to thirty millions (\$5,700,000) a year, which would have been infinitely better employed in the amelioration of wages, to say nothing of eight millions (\$1,520,000) carried in 1912 to capital account on behalf of employees pensioned during that year, nor of its retroactive provisions, nor of the slowly decreasing amounts it will add to the expenses of future years. The labor regulations imposed upon the railways have also added new expenditures over and above those brought about by such increases in force as have been necessitated by the general movement tending toward greater leisure for laborers.

The law of 1905 regarding the liability of carriers has further added to railway expenses, by means of payments for damage, to the extent of fifteen millions (\$2,850,000) a year.

When the law of 1905 had overthrown one of the conditions made by the railway systems in return for the voluntary rate reductions introduced by them, the government recognized that it could not insist upon these reductions without some compensatory arrangement. The Minister of Public Works took the almost unheard of step of promulgating increases in certain rates that were extremely low and were due for revision when the effects of the new legislation should become known. But when the time came the administration directed its whole weight of authority against the railways, to obtain their renunciation of certain surcharges which it was impracticable to refuse to them if they should insist on their rights. The railways gave in upon the promise that a slight compensation would be granted them through the revision of certain tariff regulations much more burdensome to them than really beneficial to the public. Then, as always, when it was proposed to promulgate certain rules facilitating railway service, the administration backed down in the face of demands formulated not so much by large shippers, seriously interested in the question, as by small groups who receive their instructions from agencies on the lookout for opportunities to file claims. As a final result, the railways obtained nothing in exchange for their consent to the maintenance of special tariffs, even in cases where the evidence itself showed that the provisions reducing the liability of carriers had been among the determining conditions underlying the reductions voluntarily agreed to by them.

Although the new operating expenses absorbed, and more than absorbed, the increases in revenues, the amount of capital grew and the corresponding charges grew still faster. The general increase in the rate of interest has continued simultaneously with the increase in prices for 15 years past. Of late it is especially with regard to old family investments that this increase has been manifested; the cost of living has forced a search for more productive investments; furthermore, in the face of financial and other threats that are directed from all sides upon accumulated wealth, the difference in safety between securities once regarded as absolutely sound and other investments no longer seem important. Fifteen years ago the rate of interest (including funding costs) at which the railways borrowed hardly exceeded 3.25 per cent.; today they can no longer issue securities without paying about 4 per cent. Retirement of securities becomes more difficult in the measure by which the end of the period of concession approaches; the annual amortization charge (*l'annuité des emprunts*) has increased by 0.50 to 0.75 per cent. in 15 years, and amounts to 75-115 centimes today, according to the length of time yet remaining to the concession of each system, and the charge will grow very rapidly unless measures are taken to render possible the continuation of betterments indispensable to the good of the service.

Whether the increase in capital charges and expenses of

operation bears directly upon the state in regard to its own system and the expenditures assumed by it, through the construction of new concessionary lines, and whether it directly affects the railways with which the state is closely associated through guarantees of interest and the division of profits, it reacts no less gravely upon the state budget. For other reasons as well the budget is affected by the general increase in prices and wages, being drawn upon especially for the improvement of the working conditions of all public employees—not to give satisfaction to labor associations or unions whom it would be easy to bring to their senses, but because the recruiting of civil or military employees becomes more and more difficult, and will become impossible if they are not properly compensated. The new military burdens which have been imposed upon us and the social burdens sometimes imprudently assumed, added to those which have resulted from the natural movement of prices, forced the state to secure new resources for immense sums never required before, not even after the catastrophe of 1871. At the very moment when it becomes necessary to search on all sides for new taxes, it is no longer possible to discard *a priori* any idea of an increase in transportation rates.

#### EFFECT OF INCREASES IN RATES.

Without doubt this increase will bear grievously upon agriculture, commerce and industry. But under whatever form it may arrive, the new burdens imposed upon national production will fetter that production. To burden the transportation industry, or to tax its transactions, or to attenuate its capital, all tend to diminish the productive power of a country; the problem is to so distribute the load as to render no one part of it crushing. A certain increase in railway rates must nevertheless follow upon a general increase in prices, such as was described at the beginning of this article. Soon, perhaps, the state will no longer be able in fairness either to refuse the increase to the railways, in whose prosperity it is directly interested as a partner, or to continue to operate its own system at a continuously increasing loss. Perhaps also it would be wise to use from now on additional transportation charges that are relatively low and well selected as

part of the resources of which there is need, in order to cover at least the interest on the capital expended to develop all sorts of means of communication.

The memory of the enormous part that has been played by the considerable decrease in transportation rates in modern progress must not lead us to exaggerate the inconvenience of a slight increase. The experience of actual increases abroad, as well as increases of transportation taxes in France some time ago, show that charges of this kind are not especially prohibitive provided they be moderate and well selected; and even if they were to bear heavily upon passengers traveling on passes or special tickets (*cartes de circulation*), yet they constitute a valuable means of moral uplift.

What is of significance to the public welfare is not that a special form of service like the railway service is left out of the general movement of increased prices and augmented public charges, but that these charges be not increased without absolute necessity. The policy of reducing transportation rates is an excellent one, but to carry it out it is necessary to avoid increasing beyond measure the charge upon the carriers, the expenses of operations of doubtful utility or of no utility at all, and even, if possible, the total budget. On the other hand, when it becomes absolutely necessary to increase the levy made by the public power upon national production, the users of means of communication of all kinds should justly and inevitably contribute their share, at least in the proportion by which special legislation and the general increase in prices have increased the net cost of the services rendered to them.

#### CONSTANT VOLTAGE AXLE LIGHTING SYSTEM.

At the recent convention of the Association of Railway Electrical Engineers the Electric Storage Battery Company, Philadelphia, Pa., exhibited its new constant voltage axle lighting system which was described by J. Lester Woodbridge, chief engineer of the company, at an informal dinner

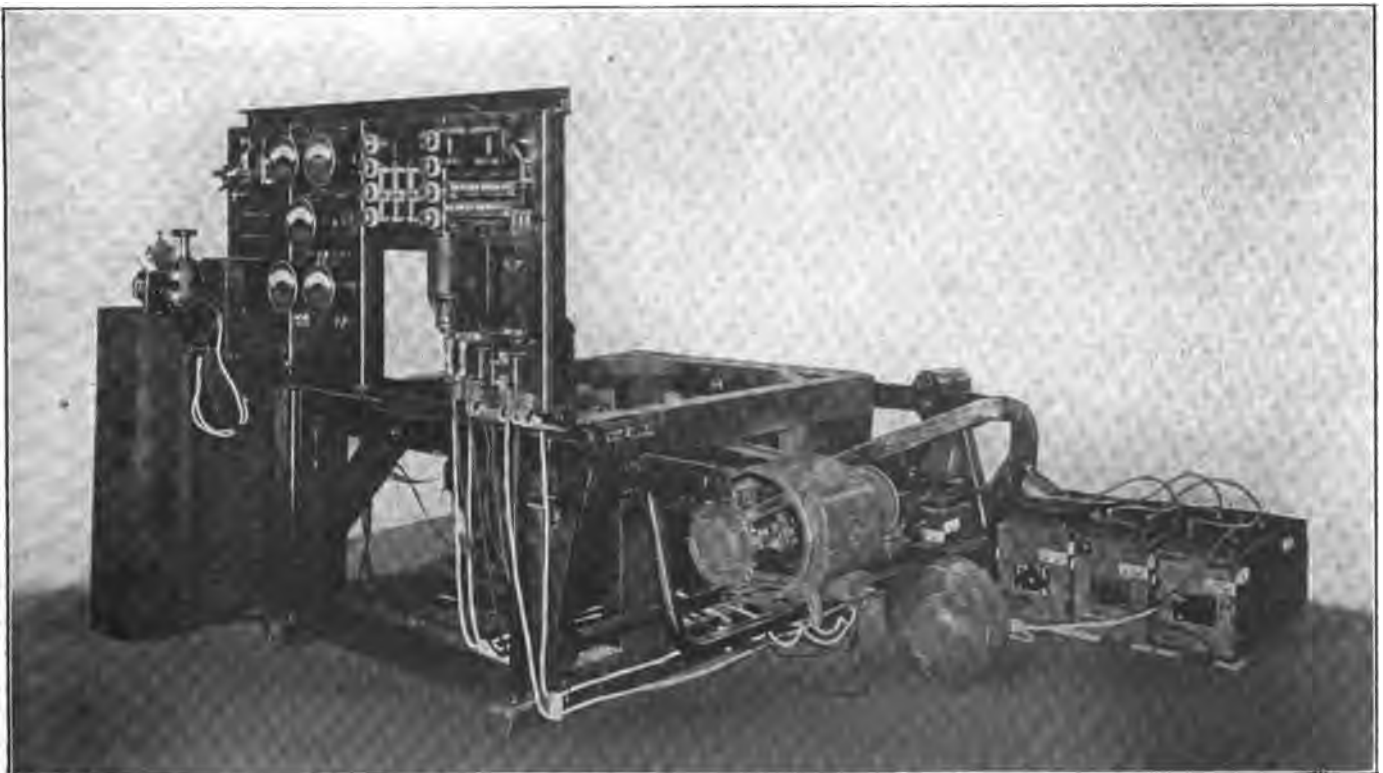

Constant Voltage Axle Lighting Equipment Arranged for Demonstration Purposes.

given to the members of the association. A description of this system was published in the *Railway Age Gazette*, May 9, 1913, page 1037. Mr. Woodbridge said in part:

The conditions under which the storage battery was called upon to operate in train lighting service and especially in axle lighting service were so unsatisfactory from the battery standpoint that they threatened to give the storage battery a most unsavory reputation, which it in no way deserved. The original axle lighting systems started with the dynamo and regulating apparatus and were designed and developed by dynamo and apparatus designers who were but little familiar with the storage battery requirements. The storage battery was included reluctantly as a necessary evil and incidentally was utilized as a reservoir to receive all excess current that was not required by the lamps, and also to furnish a means for controlling the voltage of the dynamo.

We have taken the battery as a starting point and have designed the balance of the equipment with reference to the battery characteristics and requirements. The Electric Storage Battery Company's axle lighting system is designed to retain all of the advantages of the straight storage system, while eliminating the disadvantages. In this system two new principles have been introduced: The dynamo controls the voltage on the circuit and therefore controls the voltage maintained at the battery terminals, instead of the battery controlling the voltage of the dynamo. The dynamo is designed for constant voltage rather than constant current, this constant voltage being adjusted slightly above the normal floating point of the battery at a value just sufficient to keep the battery always practically full.

It has frequently been asserted that it is impossible to fully charge the battery, or to keep it fully charged at the voltage which we have adopted; that is, approximately 2.25 volts per cell. During this entire year the test battery that has been in active railway service has not been subjected to any gassing charge, nor any charge in fact, except that which it normally receives en route from the dynamo and that without any change in the adjustment of the dynamo voltage.

We have demonstrated the fact that in our axle lighting service the difference in voltage between charge and discharge can, in actual practice, be so far reduced as to eliminate the necessity for any lamp regulator, and this without impairing the satisfactory character of the illumination and without excessive cost of lamp renewals. For an equipment of 16 cells of lead battery we find that a voltage between 35 and 36 volts maintained across the battery terminals when the dynamo is in operation is sufficient to keep the battery full and to recharge rapidly after any extensive discharge. So long as the changes in voltage are gradual a very considerable range in the intensity of illumination may be permitted without producing unsatisfactory results. In fact, the variation in illumination resulting from a gradual change from 35 volts down to 32 volts is far less than the difference in illumination at different points in the car, or the changes which take place in ordinary daylight illumination.

In addition to the controlling resistances we have an automatic switch which involves some special features. In addition to the usual shunt and series coils, a third coil is added, which is connected between the dynamo and the battery. The main shunt coil is insufficient to close the switch, or keep it closed without the assistance of this auxiliary coil, or of the series coil. The auxiliary coil, therefore, determines the closing of the switch by the difference between the dynamo and battery voltage, whereas the switch will open as soon as the current in the series coil drops to zero. On account of the latter characteristic the switch is never obliged to break an appreciable amount of current, and therefore no flickering of the lamps occurs.

The equipment that has been in service on one of the principal Western trunk lines during the past year has run 159,368 miles with no light failures, no delay to car service on account of the axle lighting equipment, and no repairs to the dynamo excepting the replacement of a defective ball bearing.

The ball bearings on the standard equipment have since been made larger. There has been no charging of the battery other than that given by the axle dynamo en route and no change in the adjustment of the controlling apparatus. For the purpose of test the battery was completely discharged before leaving Chicago for Newton, Kan., January 9, and returned January 12, practically full, no change having been made in the adjustment of the controlling apparatus. It was indicated from this service that filling the batteries with water twice a year is sufficient.

## REFUNDING OVERCHARGES IN OKLAHOMA.

The corporation commission of Oklahoma has won its suit against the railroads to reduce freight rates, and it has in its possession the money to make refunds to shippers on account of freight transported during the pendency of the suit; but claimants are likely to have to wait a year or two for their money, because the commission has not enough clerks to attend to the accounts. The legislature adjourned without making appropriation for clerk hire.

The chairman of the commission says that "probably no material progress can be made by the commission in turning the money back to the people until the next legislature meets. The refund amounts to approximately \$400,000 (on the commodity freight rates) to be returned to the shippers.

"Before the commission won this case, the railroads filed reports showing all the shipments covered by the commodity rates, and the amount of excess charges on each shipment is checked from these reports; then the railroad representatives verify the amount due. Voucher is then received from each railroad. The amount of refund due and received on the first commodity checked by the commission (coal) was as follows:

"Atchison, Topeka & Santa Fe, \$24,931; Gulf, Colorado & Santa Fe, \$7,656.77; Missouri, Kansas & Texas, \$8,869.16; Oklahoma Central, \$5,031.66; Chicago, Rock Island & Pacific, \$74,851.68; Kansas City Southern, \$2,595.46; Fort Smith & Western, \$2,883.18.

"The excess charges for the first three lines have been paid into the hands of the commission and checks sent to shippers, except where there is a controversy as to the proper person to whom the excess charges should be paid. The Rock Island line has recently paid \$74,851.68, which will be disbursed as soon as the office force can do the work incident thereto.

"The amount of excess charges on lumber, oil and building material is now being checked. Grain and grain products will be the last commodity taken up. Since we have only our regular force to do the work they can work on it only after the regular work of the commission is performed. There are approximately 200,000 shipments which will be checked.

"The Oklahoma Supreme Court has recently affirmed the case against the Pioneer Telephone Company, wherein there is \$62,057.27 to be refunded to the telephone subscribers of Oklahoma City.

"On October 7 the Supreme Court approved the express rates prescribed by the commission, wherein there will be slightly more than \$600,000 to be refunded to the express shippers of Oklahoma. There are approximately 6,000,000 express shipments to be checked.

"The telephone and express companies are now contesting the right of the commission to collect these refunds for the public, insisting that each shipper or telephone subscriber should present his claim. If their position is sustained there would not be \$90,000 in claims presented, whereas the commission would locate and send to the parties the refunds due."

STATE RAILWAY MILEAGE IN NEW ZEALAND.—There were in New Zealand on March 31, 1912, 2,808 miles of railway owned and operated by the state, and 29 miles owned and operated by private companies.

## COMMISSIONERS' REPORT ON SAFETY.

The Committee on Rails and Equipment of the National Association of Railway Commissioners, whose report, presented to the Washington convention, was noticed last week, page 871, consisted of James E. Sague (chairman), E. E. Clark, W. J. Wood, G. W. Bishop, Frank Avent, J. A. Knott and W. H. Mann. Following are extracts from those parts of the report dealing with steel rails, speed recorders and the space interval.

Owing to a variety of conditions the rail failure question is of much less public interest now than it was last year. This fact, however, is no indication that the subject is less important. The main reason for its diminished prominence is the decreased breakage of rails due to the more favorable weather conditions this year than last. These favorable conditions are indicated by the fact that the rail breakage in the state of New York for 12 months this year was 3,297 as compared with 5,900 for the preceding year. The figure for this year is about the average of several years preceding the year of greatest breakage, 1912, and it is thus indicated that in the improvement of the past year better weather conditions form the main factor.

We think there is much to indicate that the density of traffic, speed, and wheel loads are of large importance in causing rail failures, and we doubt if the effect of these factors can be entirely overcome by increasing the weight of the rail. It must be borne in mind that the area of contact between the wheel and rail cannot be materially increased by the use of heavier rails and we believe that it is impossible to say from present knowledge how much of a factor increased intensity of pressure, due to heavy wheel loads, may be in causing increased rail failures. It is probable that many rails break under severe service, showing by their fracture faulty material which would never have broken under lighter service. There will always be many cases in which it is difficult to distinguish between unfair conditions of service and defective material in determining the cause of breakage.

Much criticism has been directed against the steel manufacturers for sacrificing quality to large production, but on the other hand it must be acknowledged that the wheel weights now being used upon both cars and locomotives in the United States are so great as to be entirely without precedent in railroad history, and the combination of high speed and heavy wheel weights, together with the extremely severe track conditions frequently met in winter operations in this country, produce conditions which are most difficult to meet.

Considerable inquiry has been made with a view of obtaining further information on the subject of internal transverse fissures such as caused the Manchester accident on the Lehigh Valley Railroad. No important additional information has, however, been secured, and the fundamental cause of the Manchester wreck remains in doubt. This type of failure remains one which demands most careful consideration, especially in view of the fact that it appears to have developed more in open hearth steel than in Bessemer, and there is consequently danger that such failures will increase with the use of open hearth steel.

The report of the Bureau of Standards submitted to the Interstate Commerce Commission in the Louisville & Nashville case places much stress upon the conditions of service as tending to develop transverse fissures in the rail. It is difficult, however, to see why these fissures do not develop more generally if the conditions of service are a main cause of this type of failure. In the Louisville & Nashville case 11 transverse fissures were found in the broken rail, and it is difficult to believe that such a complete breaking up of the structure of a rail could occur unless some important defect in the quality of the rail itself was a contributing cause. We are inclined to think that the best public information on this subject is that contained in report No. 31 of the American Railway Engineering Association regarding the development of transverse fissures in 19 rails on the Pennsylvania system. The report refers to inclusion of slag as a principal cause of this defect. [The report here repeats certain conclusions of the previous year, as follows:]

Defective track conditions cause many rail failures, especially in the winter. The principal contributing defects appear to be bad surface and poor drainage.

Defective equipment causes many rail failures, especially in connection with heavy wheel weights and high speeds. The most serious cause of failures under this head is "flat wheels." Rail failures due to defective equipment are much greater in winter than in summer, and, in connection with defective track and high speeds, probably constitute the principal causes of increased breakage of rails in winter.

The speed question has received wide attention during the past year, and there appears to be some danger of exaggerating its importance as compared with other elements which lead to accident. There is, however, no question but that the education that the public and some of the railroad men have received regarding the effect of high speeds has been of great value in correcting the evil of excessive speeds, and has thus not only diminished the chances of accident, but has conduced to economy of operation.

The most notable change has been the agreement of the New York Central and the Pennsylvania to increase the running time of the fastest New York and Chicago trains from 18 to 20 hours, in accordance with the suggestion of one of the State Commissioners. This increase was for winter operation only, but the conclusion was reached by the companies to continue the 20-hour schedule through the past summer, and this decision we believe to have been wise. There is no question but that high speed schedules in winter are more dangerous than in summer, and the lengthening of winter schedules is therefore indicated as proper. There are, however, certain summer conditions which contain elements of danger which do not prevail to the same extent in winter, such as the large amount of new construction usually carried on, the renewals of ties, rails and ballast which must be conducted between trains, and the delays to traffic which result from heavy summer passenger travel, especially at the beginning and end of the season, and which increase the tendency to fast running in order to make up time with delayed trains.

Discussions with prominent officers of the railroads above referred to indicate that the lengthening of time of the fast New York-Chicago trains has resulted in nothing but benefit, and it is possibly fair to say that the 10 per cent. reduction of speed has increased the factor of safety 50 per cent. . . .

Some criticism has been made regarding the efforts of state commissions in urging the railroads to improve their records of percentages of trains on time. . . . The commissions' efforts should be devoted principally to the records of trains which appear to be systematically late, and which are run behind time month after month. Many such cases are found.

Many broken rail accidents have no doubt been prevented by the electric track circuit, and we believe that such a circuit in connection with an adequate signal system is essential to the safety of high speed operation in winter.

The final conclusions of the committee of last year are repeated [*Railway Age Gazette*, November 29, page 1038].

### SPEED RECORDERS.

One of the most important subjects to be considered in connection with equipment at this time would appear to be that of speed recorders.

An important use of speed recorders is being made by the Delaware & Hudson Company on 20 Mallet locomotives. These locomotives are among the heaviest in the world, and are designed especially for slow pushing service on mountain grades. It was thought necessary for good operation and economical maintenance to restrict the speed of these locomotives to 15 miles an hour, and to secure positive evidence that such instructions are being carried out the "Flaman Speed Indicator" has been applied. This is a German invention which makes a chart of the entire trip and gives a diagram of the speed, the location on the line, and a record of any abuse to which the engine may have been subjected on account of the drivers slipping. We are advised that the first year's successful operation of these engines



is due principally to the indisputable evidence gathered from the speed recorders and to the resulting discipline which can be fairly administered where violation of the instructions is shown. It is stated that it is rarely necessary to call the enginemen's attention to irregularities shown by this device as they fully recognize that it tells the story accurately and that discipline will be administered in accordance therewith. Cost of maintenance of this apparatus is thought to be about \$50 a year, although the trial has not been extensive enough to settle this point accurately.

We feel that much caution should be exercised in recommending the use of any additional complicated apparatus in connection with train operation. The difficulty of maintaining the present apparatus and of instructing engineers, trainmen and shop men to understand and use it properly is enormous, and imposes one of the great burdens under which operating men have to work. We, however, believe that the advantages to be secured both in economy and safety from a reliable speed recorder are sufficient to justify extensive and thorough trial, and we think that the use of such apparatus will eventually become as general in this country as it is in Europe.

The most important class of accidents . . . has been rear collisions. Much attention has been given by some of the commissions to the prevention of this class of accidents. It appears to be clear that the most important elements in this connection are the signaling system, the appreciation and devotion to duty of engine and train men, and the selection, instruction and discipline of these men. We think it will be admitted that most of the recent accident records indicate the possibility of improvement in one or more of these directions.

[The report here recounts the history of the P C equipment of the Westinghouse Air Brake Company, with which the engineman can always obtain full emergency braking power, even immediately following a service application.]

#### THE SPACE INTERVAL.

In some cases effort has been made to improve conditions by the use of the overlapping system of signals. The most notable instance in regular railroad service is the practice of the Fort Wayne Line of the Pennsylvania System. The signals on this railroad are so arranged that each train is protected by two stop signals and one caution signal. An additional block is therefore provided as a space interval above that used in the ordinary automatic signaling system. An investigation of the signal system of the Fort Wayne Line has just been made by an engineer for the Second District Public Service Commission of New York, and he advises that it is operating satisfactorily and is considered by the officers of the Fort Wayne to be of decided value in promoting safety, and to have had a material effect in reducing the number of rear-end collisions. It is understood that this "overlapping" system of signals reduces the capacity of the line through the fact that trains are automatically spaced farther apart than in ordinary signaling, but it is thought that the increase in safety more than compensates for this reduction of capacity. Prominent officers of the line state that the increased protection of trains afforded by this signal system has an important effect in reducing the strain under which the operating officers have been working, and that a return to the ordinary system would not be considered.

It, however, appears to be the fact that the majority of operating men and signal engineers through the country prefer what may be called the standard signaling system, and believe that the "overlapping" system such as used on the Fort Wayne does not materially increase safety, and in fact has a tendency to encourage lack of attention to signals by engineers.

The above discussion is given not with the purpose of indicating any opinion on the part of members of the committee, but to show the complex considerations which enter into this problem. It is therefore submitted that much study and investigation must be made before important action on this subject through legislation or by commission orders can be safely decided.

## General News.

The freight house of the Grand Trunk at St. Catherines, Ont., was destroyed by fire last week; estimated loss, \$50,000.

The Texas & Pacific and its telegraph operators have reached an agreement on a new wage schedule, which affects some 450 men.

A bill has been introduced in Congress, and has already been passed by the Senate, making interstate pipe lines conveying gas subject to the act to regulate commerce.

The Canadian Northern announces that within about ten days freight trains will be run through between Montreal and Toronto. Passenger trains will not be run on the new line until the spring.

Tunnel No. 7, on the Southern Pacific, between Santa Margarita and San Luis Obispo, Cal., which has been closed since September 24, by a fire which required sealing both ends, was restored to service last week.

Hearings in the wage controversy between the Chicago, Burlington & Quincy and its conductors and trainmen were begun before the federal board of arbitration, of which H. S. Bontell is chairman, on November 6 at Chicago.

The arbitrators who had adjudicated the wages of firemen on the eastern roads a few months ago are sitting in New York this week to consider differences which have arisen concerning the construction of some of the provisions of the award.

Track repair employees numbering, it is said, 5,000 have asked the Canadian Pacific for an increase in pay and application has been made to the Canadian government for the establishment of a Board of Conciliation to investigate the differences between the company and the employees.

On the Lehigh Valley an order has been issued to have all water barrels and fire pails, in which water is kept standing, treated with a small quantity of calcium chloride to prevent the water from freezing. At the same time this calcium chloride will tend to prevent evaporation.

The Post Office Department estimates that the gross receipts from the parcel post business during the present calendar year will amount to \$80,000,000, of which \$30,000,000 will be profit. This is double the amount of profit expected when the parcel post was established at the beginning of 1913.

In the Federal Court at Birmingham, Ala., November 6, John L. Parker was sentenced to six years' imprisonment for stealing shoes out of a freight car in the yard at Birmingham, May 4; this under the recent act of Congress, giving the Federal Courts jurisdiction over robberies from cars in interstate commerce.

Firemen, enginemen, conductors and trainmen on the Southern Pacific lines in Texas are taking a strike vote because of the refusal of the company to negotiate regarding certain demands of the men with a joint committee representing the four brotherhoods. The company insisted on dealing with the four organizations separately.

The upper house of Congress has adopted a resolution introduced by Senator Luke Lea, directing the Interstate Commerce Commission to inquire into the relations of the Louisville & Nashville with the Nashville, Chattanooga & St. Louis, to determine whether they would be competitors if separately owned. The resolution also directs an inquiry into the relations of these roads with the Tennessee Midland, the Tennessee, Paducah & Alabama, and the Western & Atlantic. It is proposed to determine whether these roads conspire to fix prices, what free passes are issued and to whom, and what relations the railroads have to state politics.

#### Collision on Our Government Railroad.

A press despatch from Panama, November 7, reports a collision on the Panama Railroad at Paraiso between a regular passenger train and a train consisting of a locomotive and one platform car, carrying workmen. The conductor, the engineman and four negro laborers were killed and eight other persons were injured.

**Unfilled Tonnage of the Steel Corporation.**

The report of the United States Steel Corporation shows that on October 31 the unfilled tonnage was 4,513,767 tons, a decrease of 490,018 tons from the previous month. This was a surprise, as a decrease of not more than 300,000 tons had been anticipated. The unfilled tonnage on the books of the company on October 31, 1913, was smaller than at any time since November 30, 1911, when it was 4,141,955 tons.

**Soft Radiance Not Satisfactory.**

The indirect lighting system of the Merchants' Limited, one of the New Haven road's five-hour trains between Boston and New York, is to be supplemented by the installation of tungsten lights along the beam on the lower deck of each car; this to increase the light for reading purposes, concerning which there has been some complaint. When first installed the inverted globes suspended from the ceiling of the cars each contained one 100-Watt tungsten lamp. By displacing these with three 50-Watt lamps an increase of 50 per cent. in the amount of light was obtained, but even with this change we are informed, some of the regular users of the trains complained of difficulty in reading in the "soft radiance" that pervades the cars.

**Railways Needed in Texas.**

The United States Geological Survey Press bulletin points out the need of railroads in the development of the gold fields in Alaska. The government authority might have added that railroads are also badly needed in Texas to develop our agricultural resources. We have only 27,000,000 acres of land in cultivation out of a total area of 167,000,000 acres, and the larger part of our idle land is susceptible to a high degree of cultivation; then, too, agricultural development means permanent tonnage. We have most everything in Texas which railroad investors require, except perhaps stable conditions. No railroad company will run tracks where they will be buried under the landslide of uncertainty or blockaded by the snowstorm of bitter and merciless hatred. They want the sunshine of hope and the soft winds of friendship. Let us have an era of peace and prosperity.—*Bulletin of the Texas Commercial Secretaries and Business Men's Association.*

**Safety of Railway Travel.**

There is an exaggerated idea of the danger of railway travel. There are a number of cities and some entire states in which records of the causes of deaths have been compiled by the Census Bureau. These are embraced in what is termed the registration area, which includes twenty-two states and the larger cities in fifteen other states. The registration area is estimated by the United States Census Bureau to embrace 63.1 per cent. of the total population of the United States. For the calendar year 1911, the Census Bureau reported 42,331 cases of accidental death, exclusive of railway accidents, in the registration area. As bearing on the comparative safety of different ways of travel, it may be noted that, as compared with 318 deaths of passengers from railway accidents in the entire United States, there were, in the registration area, 1,883 deaths from street-car accidents, 1,291 from automobile accidents, and 2,237 from accidents in connection with other vehicles. The total number of deaths in the registration area from accidents in connection with street cars, automobiles, and other vehicles in the calendar year 1911 was 5,411, or more than the total number of passengers, railway employees, and all other persons, excepting trespassers, killed in railway accidents of all kinds in the twelve months ended June 30, 1912, including accidents in railway shops.—*W. W. Finley.*

**The Trainmen's Increased Pay.**

The mere amount of the award is a fraction of 1 per cent. of the total railway disbursements, and could be endured. But it signifies an uneconomic distribution of railway resources. The companies are under criticism for waste and inefficiency, and here is proof that they are not allowed to be efficient in the way of all other industrial enterprises. Both their income and their outgo are ruled by powers over which they have no control. The public has taken sides with the wage earners against the corporations for motives too natural and obvious to need

enlargement. This public opinion has permeated legislatures in a manner to influence legislation. It has even penetrated the Interstate Commerce Commission. The commission no doubt has administered the law according to its best lights, but nobody has said that doubtful points were decided in the interest of the railways. In fact, the exact opposite has been said. There is reason to fear that unless the commission shall discover a light of reason like the Supreme Court, it will find itself in an indefensible position, having served the public badly through a mistaken idea that an anti-railway policy was the sure way to public favor. It is not a service to the public to compel the railways to overpay their employees, or to employ more men than they need. The railways in question have invested two billion dollars more, and have earned \$8,000,000 less during the three years since they were forbidden to advance rates, and have been compelled to increase expenses.—*New York Times.*

**Remarkable Records of Two Enginemen.**

H. W. McMaster, general manager of the Wheeling & Lake Erie, has called attention to the remarkable records of two of the enginemen on that road.

Michael Donovan entered the service of the Wheeling & Lake Erie as an engineer on March 11, 1883, and after over 30 years of continuous service with very few vacations, he resigned, effective October 31, 1913. The records show that during the full period of his employment he never had occasion to go to the superintendent's or master mechanic's office on a matter of discipline, and so far as can be learned he was never even reprimanded by any officer connected with either the transportation or mechanical departments. The only entries on his record are of a commendatory nature and wherein credit marks were allowed; and now at the age of 55 he leaves railroad service in perfect physical condition.

Another man of long service with the company is Ira Cowen, who has been an engineman since November 5, 1881. He was born in 1842, and after having served for three years in the army during the Civil War, was for 17 years in the service of the Atlantic & Great Western, as fireman for 2 years and engineman for 15 years, leaving that company to go to the Wheeling & Lake Erie with a clear record. During his 32 years on the Wheeling & Lake Erie his service has been continuous, with the exception of a slight interruption brought about by an injury sustained while riding on a train as a passenger. Mr. Cowen has filled the position of engineman for 47 years, without a demerit mark being placed against his record.

**Chicago City Transit.**

The city council of Chicago has authorized the publication of an advertisement for proposals to construct a comprehensive system of passenger subways within the city limits, to be operated independently of all existing surface and elevated transportation lines. It is proposed that these subways shall ultimately be owned by the city through the amortization of the construction debt out of earnings.

The ordinance authorizing these invitations to private capital to enter into subway construction in partnership with the city specifies certain subway routes approximating 57 miles in extent (approximately 135 miles of track). The cost estimates for these routes approximately \$96,000,000 for subway construction and \$34,000,000 for equipment, or a total of \$130,000,000.

**Trainmen and Their Employers in Tennessee.\***

In nearly every issue of your paper there appears an article telling of some bad railroad wreck, but I wonder if the public understands just how these men are worked. There is a federal law that says these men shall not work more than 16 hours during the 24. . . . I have known cases of one drawbar being pulled out of a train and the time consumed in setting this car out was 15 minutes, and the time used by the company to run this train was five hours and 40 minutes in excess of the 16 hours allowed. I have known of cases where men were called to leave a terminal 45 minutes after a wreck had been cleared a hundred miles from the starting point of this train. They were then in-

\*Extracts from letters published in the Memphis *Commercial Appeal*, October 26 and November 2.

structed to disregard the hours of service law and take the train to the terminal on account of that wreck; and then be 27 or 28 hours making the trip. They will tie you up 15 or 25 miles from your terminal, and instruct you that a crew will come after you. You stay in this sidetrack, where there is no place to go to bed and no place to get anything to eat, and when the crew comes after you and you get to the terminal, this eight or 10 hours that you have been laying around in this blind siding or some small town where every inhabitant is in bed is counted as your rest. . . . Don't blame the engineer or the flagman and have this awful charge of "murder" hanging over him when he has been on duty 40 hours without sleep or rest of any kind. We want to do right and our wives and mothers pray every night that we will prove true, but we can't do it every time if our eyes refuse to stay open. I am an engineer, I cannot give you my name, for if I did it would not be long until I would be looking for another job. They wouldn't fire me for this, but as soon as they had any little thing they could get me for they would surely do it.

## REPLY.

I work daily with both train and enginemen. I am unbiased and, I believe, fair minded. I have not been wedded to railroads as a result of favoritism, and, still more happily, have been free of the yoke of unionism, which swallows up the individual and destroys man as a unit in his industrial relations (I mean unionism as practiced, and not in theory); and the sole reason I have for not having my name at the end of this letter is the suspicion that would be created in the mind of the reader that I am courting favor with the company I serve.

The public is either indifferent or is misled by such perversions of truth as set forth by your correspondent, October 26, who makes a general charge against all the railroads of three states.

[The writer here discusses the 16-hour law and the duties of the officers and the employees in the enforcement of the law; and goes on:] I would suggest to the wives and mothers referred to in the article, that if they will help the Almighty by encouraging their husbands and sons to take their rest, instead of giving their consent to their sitting around shops and stores and standing on street corners in idle conversation, or taking them out shopping, or to theaters or picture shows, or calling on them to do chores about the house, and then praying when they go out on the road without having had proper sleep, the Almighty would not have to look after them so closely while on duty. The men shirk their responsibility in failing to sleep in rest periods.

It may be of interest here to state that before this law was ever thought of the railroads had agreements with their men covering these rest periods. Some men always took their rest under this concession and were perhaps more highly regarded by their officers than the fellow whose greed and avarice drove him to work beyond his endurance, and who converted hours into dollars, regardless of his own safety or the safety of those who trusted him.

The whole article referred to suggests that locomotive engineers are without blame, are a meek, long-suffering and overworked body of men, ruled by a ruthless, man-killing, law-defying corporation. My observation is that neither term applied to either party is correct. These same men, in this territory, earn, or rather draw, from the railroads from \$150 to \$270 a month by working an average of 10 hours a day; they have less hardship and more comfort on duty than your automobile driver, your laundry wagon driver or the man who hauls your coal and wood. The railroad company pays them for every hour they work, and for many hours they do not work, and grants them every reasonable request (and many unreasonable ones, in my opinion), and labors constantly to better their working conditions. It comes in bad taste for one of their members to make false charges against the very men who furnish them employment. How much more becoming it would be to help the railroads and government to find and weed out the unworthy, unreliable drone, instead of covering up in the bosom of their fraternity the rottenness that might exist, and then attempt to pervert justice by resorting to demagogic tactics in raising the present-day cry of "tyrannous corporations."

No ingenuity will ever devise any safeguard that can entirely overcome the errors of the human mind. So long as railroads exist and men live there will be accidents. So long as those who man the trains cover up the weaknesses and shortcomings of their brothers and do not raise the standard of their fitness,

but rely upon their union, with its evil of "seniority," instead of merit and ability, there will be still more railroad accidents.

## A Correction.

The place and dates of the conventions of the Master Car Builders' Association and the American Railway Master Mechanics' Association were decided at a meeting of the executive committees of the Master Car Builders' Association, the American Railway Master Mechanics' Association and the Railway Supply Manufacturers' Association, and not by the executive committee of the Railway Supply Manufacturers' Association alone as mentioned in the *Railway Age Gazette* of October 31, page 836.

## Western Canada Railway Club.

At the meeting of the Western Canada Railway Club on November 10, in Winnipeg, Man., there was a continued discussion of the paper read at the previous meeting, entitled *Terminal Operation in Its Relation to the Public*. A paper was also read by W. J. Logan, auditor, Hudson Bay Railway, entitled *Auditing of Railroads under Construction*.

## Railway Club of Pittsburgh.

At the meeting of the Railway Club of Pittsburgh, to be held at the Monongahela House, Pittsburgh, Pa., November 28, C. W. Garrett, secretary of the committee on workingmen's compensation, Pennsylvania Lines West of Pittsburgh, will read a paper on *Workingmen's Compensation, a Study in Evolution*.

## MEETINGS AND CONVENTIONS.

The following list gives names of secretaries, dates of next or regular meetings, and places of meeting.

- AIR BRAKE ASSOCIATION.—F. M. Nellis, 53 State St., Boston, Mass. Next convention, May, 1914.
- AMERICAN ASSOCIATION OF DEMURRAGE OFFICERS.—A. G. Thomason, Boston, Mass. Convention, May 19, 1914, St. Louis.
- AMERICAN ASSOCIATION OF GENERAL PASSENGER AND TICKET AGENTS.—W. C. Hope, New York.
- AMERICAN ASSOCIATION OF FREIGHT AGENTS.—R. O. Wells, East St. Louis, Ill. Next convention, April 21, Houston, Tex.
- AMERICAN ASSOCIATION OF RAILROAD SUPERINTENDENTS.—E. H. Harben, St. Louis, Mo.; 3d Thursday and Friday in May.
- AMERICAN ELECTRIC RAILWAY ASSOCIATION.—H. C. Donecker, 29 W. 39th St., New York.
- AMERICAN ELECTRIC RAILWAY MANUFACTURERS' ASSOC.—H. G. McConaughy, 165 Broadway, New York. Meetings with Am. Elec. Ry. Assoc.
- AMERICAN RAILWAY ASSOCIATION.—W. F. Allen, 75 Church St., New York. Next meeting, November 19, 1913, Chicago.
- AMERICAN RAILWAY BRIDGE AND BUILDING ASSOCIATION.—C. A. Lichty, C. & N. W., Chicago. Next convention, October 20-22, 1914, Los Angeles, Cal.
- AMERICAN RAILWAY ENGINEERING ASSOCIATION.—E. H. Fritch, 900 S. Michigan Ave., Chicago. Next convention, March 17-20, Chicago.
- AMERICAN RAILWAY MASTER MECHANICS' ASSOCIATION.—J. W. Taylor, 109 Colony building, Chicago.
- AMERICAN RAILWAY TOOL FOREMEN'S ASSOCIATION.—A. R. Davis, Central of Georgia, Macon, Ga.
- AMERICAN SOCIETY FOR TESTING MATERIALS.—Prof. E. Marburg, University of Pennsylvania, Philadelphia, Pa.
- AMERICAN SOCIETY OF CIVIL ENGINEERS.—C. W. Hunt, 229 W. 57th St., New York; 1st and 3d Wed., except June and August, New York.
- AMERICAN SOCIETY OF ENGINEERING CONTRACTORS.—J. R. Weninger, 11 Broadway, New York; 2d Tuesday of each month, New York.
- AMERICAN SOCIETY OF MECHANICAL ENGINEERS.—Calvin W. Rice, 29 W. 39th St., New York.
- AMERICAN WOOD PRESERVERS' ASSOCIATION.—F. J. Angier, B. & O., Baltimore, Md. Next convention, January 20-22, 1914, New Orleans, La.
- ASSOCIATION OF AMERICAN RAILWAY ACCOUNTING OFFICERS.—C. G. Phillips, 143 Dearborn St., Chicago. Annual meeting, May 28, Atlantic City, N. J.
- ASSOCIATION OF RAILWAY CLAIM AGENTS.—C. W. Egan, B. & O., Baltimore, Md. Next convention, May, 1914, St. Paul, Minn.
- ASSOCIATION OF RAILWAY ELECTRICAL ENGINEERS.—Jos. A. Andreucetti, C. & N. W. Ry., Chicago.
- ASSOCIATION OF RAILWAY TELEGRAPH SUPERINTENDENTS.—P. W. Drow, 112 West Adams St., Chicago. Next convention, May 20-23, New Orleans, La.
- ASSOCIATION OF TRANSPORTATION AND CAR ACCOUNTING OFFICERS.—G. F. Conrad, 75 Church St., New York. Next meeting, December 9-10, Galveston, Tex.
- ASSOCIATION OF WATER LINE ACCOUNTING OFFICERS.—W. R. Evans, Chamber of Commerce, Buffalo, N. Y.
- BRIDGE AND BUILDING SUPPLY MAN'S ASSOCIATION.—L. D. Mitchell, Detroit Graphite Co., Detroit, Mich. Meeting with American Railway Bridge and Building Association.

# Traffic News.

James J. Hill, L. W. Hill and a party of officials and directors of the Hill roads, took part in the formal opening of Glacier National Park for the winter season on November 5.

Shipments of anthracite coal in October amounted to 6,665,321 tons, as against 6,338,194 tons in October, 1912, a decrease of 327,127 tons. Total shipments in the first ten months of 1913, 57,620,079 tons.

After protracted negotiations with grain shippers the Illinois Central has announced that it will grant an elevation allowance of one-fourth cent a bushel on grain shipped to Chicago from Mississippi valley points.

The "Santa Fe De Luxe" train, the 63-hour train to Southern California on the Atchison, Topeka & Santa Fe, will begin its third winter season on December 9, and will leave Chicago every Tuesday during the winter months. The train this year will be composed wholly of new cars.

The Pennsylvania Railroad has notified officers of the State of Pennsylvania that the road, under the new Public Service Commission law of that State, can no longer carry cans of young fish without charge. The Department of Fisheries says that without free transportation it will be impossible to distribute fish throughout the state, as heretofore.

The report of the Department of Agriculture, issued this week, estimates the total corn crop of the country this year, at 2,463,017,000 bushels, or about 89,000,000 bushels greater than was estimated a month ago. Reserves of corn on the farms are now estimated to amount to about 138,000,000 bushels, or more than twice the quantity reported one year ago.

It is announced that the Southern Pacific will soon make important reductions in freight rates on westbound traffic by way of San Francisco, destined for points in Asia. The reductions are said to be intended to meet lower through rates, which now prevail by way of Puget Sound and over the Canadian Pacific. The Atchison and other lines no doubt will follow any action taken by the Southern Pacific.

The Interstate Commerce Commission has changed from December 1 to February 1, the date on which the express companies must comply with the order of the commission reducing the rates for the transportation of merchandise. The commission has made some alterations in the appendices of its order of July 24, 1913, including some amendments in the rules stated in Appendix A. There are also changes in the blocks in which some shipping points are placed—for example, the suburbs of Chicago are now included in the Chicago block, and there are analogous changes for some of the suburbs of New York, Philadelphia, etc.

Joint through freight rates on commodities moving over the lines of the Southern Pacific to and from its subsidiaries, the Pacific Electric and the Visalia Electric, were announced last week. These rates, by the elimination of certain local charges, will place shippers and growers along the electric lines on a basis similar to that on steam lines, and are a new departure in California. It is said that similar arrangements with the Pacific Electric will include the San Pedro, Los Angeles & Salt Lake and the Union Pacific, and that a like arrangement will be made between the Visalia Electric and the Western Pacific.

The team owners of Philadelphia, who for a long time have been complaining of alleged neglect at the freight houses of the railroads in that city, have sent a complaint to the Interstate Commerce Commission, charging ill-treatment of this kind in many places; and they say that they have the co-operation of a team owners' association which has members in 60 large cities; and this national association, we are told, controls 350,000 horses and 4,000 automobile trucks. The Interstate Commerce Commission will give a hearing on the complaint at Philadelphia, November 25. It is claimed that freight houses are not equipped with suitable facilities and that teamsters have to expend much time and effort in hunting up freight for which they call.

## National Industrial Traffic League.

A meeting of the National Industrial Traffic League has been called to be held at the Hotel La Salle, Chicago, on Thursday

- CANADIAN RAILWAY CLUB.—James Powell, Grand Trunk Ry., Montreal, Que.; 24 Tuesday in month, except June, July and Aug., Montreal.
- CANADIAN SOCIETY OF CIVIL ENGINEERS.—Clement H. McLeod, #13 Duxchester St., Montreal, Que.; Thursday, Montreal.
- CAR FOREMEN'S ASSOCIATION OF CHICAGO.—Aaron Kline, 841 North 50th Court, Chicago; 2d Monday in month, Chicago.
- CENTRAL RAILWAY CLUB.—H. D. Vought, 95 Liberty St., New York; 2d Thurs. in Jan. and 2d Fri. in March, May, Sept., Nov., Buffalo, N. Y.
- CIVIL ENGINEERS' SOCIETY OF ST. PAUL.—L. S. Posnerdy, Old State Capitol building, St. Paul, Minn.; 2d Monday, except June, July, August and September, St. Paul.
- ENGINEERS' SOCIETY OF PENNSYLVANIA.—E. R. Dasher, Box 704, Harrisburg, Pa.; 1st Monday after second Saturday, Harrisburg, Pa.
- ENGINEERS' SOCIETY OF WESTERN PENNSYLVANIA.—E. K. Hiles, Oliver building, Pittsburgh; 1st and 3d Tuesday, Pittsburgh, Pa.
- EMERIT CLAIM ASSOCIATION.—Written P. Taylor, Richmond, Va. Next convention, May 20-22, Galveston, Tex.
- GENERAL SUPERINTENDENTS' ASSOCIATION OF CHICAGO.—E. S. Koller, 226 W. Adams St., Chicago; Wed. preceding 3d Thurs., Chicago.
- INTERNATIONAL RAILWAY CONGRESS.—Executive Committee, 11, rue de Louvain, Brussels, Belgium. Convention, 1915, Berlin.
- INTERNATIONAL RAILWAY FUEL ASSOCIATION.—C. G. Hall, 922 McCormick building, Chicago. Annual convention, May 18-22, Chicago.
- INTERNATIONAL RAILWAY GENERAL FOREMEN'S ASSOCIATION.—Wm. Hall, 829 West Broadway, Winona, Minn. Next convention, July, Chicago.
- INTERNATIONAL RAILROAD MASTER BLACKSMITHS' ASSOCIATION.—A. L. Woodworth, Lima, Ohio. Next convention, third Tuesday in August.
- MAINTENANCE OF WAY & MASTER PAINTERS' ASSOCIATION OF THE UNITED STATES AND CANADA.—W. G. Wilson, Lehigh Valley, Easton, Pa. Next convention, November 18-20, Louisville, Ky.
- MASTER BOILER MAKERS' ASSOCIATION.—Harry D. Vought, 95 Liberty St., New York.
- MASTER CAR BUILDERS' ASSOCIATION.—J. W. Taylor, Old Colony building, Chicago.
- MASTER CAR & LOCOMOTIVE PAINTERS' ASSOC. OF U. S. AND CANADA.—A. P. Dane, B. & M., Reading, Mass.
- NATIONAL RAILWAY APPLIANCE ASSOC.—Bruce V. Crandall, 537 So. Dearborn St., Chicago. Meetings with Am. Ry. Eng. Assoc.
- NEW ENGLAND RAILROAD CLUB.—W. E. Cade, Jr., 683 Atlantic Ave., Boston, Mass.; 2d Tuesday in month, except June, July, Aug. and Sept., Boston.
- NEW YORK RAILROAD CLUB.—H. D. Vought, 95 Liberty St., New York; 3rd Friday in month, except June, July and August, New York.
- NORTHERN RAILROAD CLUB.—C. L. Kennedy, C. M. & St. P., Duluth, Minn.; 4th Saturday, Duluth.
- PEORIA ASSOCIATION OF RAILROAD OFFICERS.—M. W. Rotchford, Union Station, Peoria; 2d Thursday.
- RAILROAD CLUB OF KANSAS CITY.—C. Manlove, 1008 Walnut St., Kansas City, Mo.; 3d Friday in month, Kansas City.
- RAILWAY BUSINESS ASSOCIATION.—Frank W. Noxon, 2 Rector St., New York. Annual dinner, second week in December, 1913, New York.
- RAILWAY CLUB OF PITTSBURGH.—J. B. Anderson, Penna. R. R., Pittsburgh, Pa.; 4th Friday in month, except June, July and August, Pittsburgh.
- RAILWAY ELECTRICAL SUPPLY MANUFACTURERS' ASSOC.—J. Scribner, 1021 Monadnock Block, Chicago. Meetings with Assoc. Ry. Elec. Engrs.
- RAILWAY FIRE PROTECTION ASSOCIATION.—C. B. Edwards, Mobile & Ohio, Mobile, Ala.
- RAILWAY GARDENING ASSOCIATION.—J. S. Butterfield, Lee's Summit, Mo.
- RAILWAY DEVELOPMENT ASSOCIATION.—W. Nicholson, Kansas City Southern, Kansas City, Mo.
- RAILWAY SIGNAL ASSOCIATION.—C. C. Rosenberg, Bethlehem, Pa.
- RAILWAY STOREKEEPERS' ASSOCIATION.—J. P. Murphy, Box C, Collinwood, Ohio.
- RAILWAY SUPPLY MANUFACTURERS' ASSOC.—J. D. Conway, 2135 Oliver bldg., Pittsburgh, Pa. Meetings with M. M. and M. C. B. Assocs.
- RAILWAY TEL. & TEL. APPLIANCE ASSOC.—W. E. Harkness, 284 Pearl St., New York. Meetings with Assoc. of Ry. Teleg. Sups.
- RICHMOND RAILROAD CLUB.—F. O. Robinson, Richmond, Va.; 2d Monday except June, July and August.
- ROADMASTERS' AND MAINTENANCE OF WAY ASSOCIATION.—L. C. Ryan, C. & N. W., Sterling, Ill.
- ST. LOUIS RAILWAY CLUB.—B. W. Frauenthal, Union Station, St. Louis, Mo.; 2d Friday in month, except June, July and Aug., St. Louis.
- SIGNAL APPLIANCE ASSOCIATION.—F. W. Edmonds, 3868 Park Ave., New York. Meeting with annual convention Railway Signal Association.
- SOCIETY OF RAILWAY FINANCIAL OFFICERS.—C. Nyquist, La Salle St. Station, Chicago.
- SOUTHERN ASSOCIATION OF CAR SERVICE OFFICERS.—E. W. Sandwich, A. & W. P. Ry., Montgomery, Ala.
- SOUTHERN & SOUTHWESTERN RAILWAY CLUB.—A. J. Merrill, Grant bldg., Atlanta, Ga.; 3d Thurs., Jan., March, May, July, Sept., Nov., Atlanta.
- TOLEDO TRANSPORTATION CLUB.—J. G. Macomber, Woolson Spice Co., Toledo, Ohio; 1st Saturday, Toledo.
- TRACK SUPPLY ASSOCIATION.—W. C. Kidd, Ramapo Iron Works, Hillsburn, N. Y. Meetings with Roadmasters' and Maintenance of Way Association.
- TRAFFIC CLUB OF CHICAGO.—W. H. Wharton, La Salle Hotel, Chicago.
- TRAFFIC CLUB OF NEW YORK.—C. A. Swope, 290 Broadway, New York; last Tuesday in month, except June, July and August, New York.
- TRAFFIC CLUB OF PITTSBURGH.—D. L. Wells, Erie, Pittsburgh, Pa.; meetings monthly, Pittsburgh.
- TRAFFIC CLUB OF ST. LOUIS.—A. F. Versen, Mercantile Library building, St. Louis, Mo. Annual meeting in November. Noonday meetings October to May.
- TRAIN DISPATCHERS' ASSOCIATION OF AMERICA.—J. F. Mackie, 7122 Stewart Ave., Chicago. Next convention, June 16, Jacksonville, Fla.
- TRANSPORTATION CLUB OF BUFFALO.—J. M. Sells, Buffalo; first Saturday after first Wednesday.
- TRANSPORTATION CLUB OF DETROIT.—W. R. Hurley, L. S. & M. S., Detroit, Mich.; meetings monthly.
- TRAVELING ENGINEERS' ASSOCIATION.—W. O. Thompson, N. Y. C. & H. R., East Buffalo, N. Y. Next meeting, Chicago.
- UTAH SOCIETY OF ENGINEERS.—Fred D. Ulmer, Oregon Short Line, Salt Lake City, Utah; 3rd Friday of each month, except July and August.
- WESTERN CANADA RAILWAY CLUB.—W. H. Rosevear, P. O. Box 1707, Winnipeg, Minn.; 2d Monday, except June, July and August, Winnipeg.
- WESTERN RAILWAY CLUB.—J. W. Taylor, Old Colony building, Chicago; 3d Tuesday of each month, except June, July and August.
- WESTERN SOCIETY OF ENGINEERS.—J. H. Warder, 1735 Monadnock Block, Chicago; 1st Monday in month, except July and August, Chicago.

and Friday, November 13 and 14. The annual dinner was to be held on Thursday evening at the Hotel La Salle with H. A. Wheeler, president of the chamber of commerce of the United States, and George T. Bell, commissioner of the traffic bureau of the Sioux City Commercial Club, as speakers.

**Car Balance and Performance.**

Arthur Hale, chairman of the committee on relations between railroads of the American Railway Association, in presenting statistical bulletin No. 156, covering car balances and performances for July, 1913, says:

The miles per car per day for July were 23.7, compared with 24.3 in June. This figure for July, 1912, was 23.2.

Ton miles per car per day for July were 375, compared with 377 in June. This is an increase of 3.59 per cent. over the figure for July, 1912, which was 362.

The proportion of home cars on line increased one point to 59 per cent. in July, 1913. This is also an increase of one point over the figure for July, 1912.

The per cent. of loaded car mileage decreased from 69.0 per

cent. in June to 68.1 per cent. in July, 1913. This figure for July, 1912, was 69.0 per cent.

The average earnings per car per day for all cars on line decreased 7 cents to \$2.40 in July, 1913. This figure for July, 1912, was \$2.49.

The table on page 931 gives the car balance and performance in the month covered by the report and the diagram shows car earnings and car mileage and different car performance figures monthly from July, 1907:

**Freight Rates in North Carolina.**

Pursuant to an offer made in September by the principal railways—the Southern, the Atlantic Coast Line, the Seaboard Air Line and the Norfolk & Western—freight rates from points west of Buffalo and Pittsburgh to points in North Carolina, are to be materially reduced, the legislature of the state having approved an adjustment made by the state corporation commissioners in consultation with the railroads. It is estimated that the total diminution of freight bills will amount to \$2,000,000 a year, said to be “the largest and most comprehensive concession

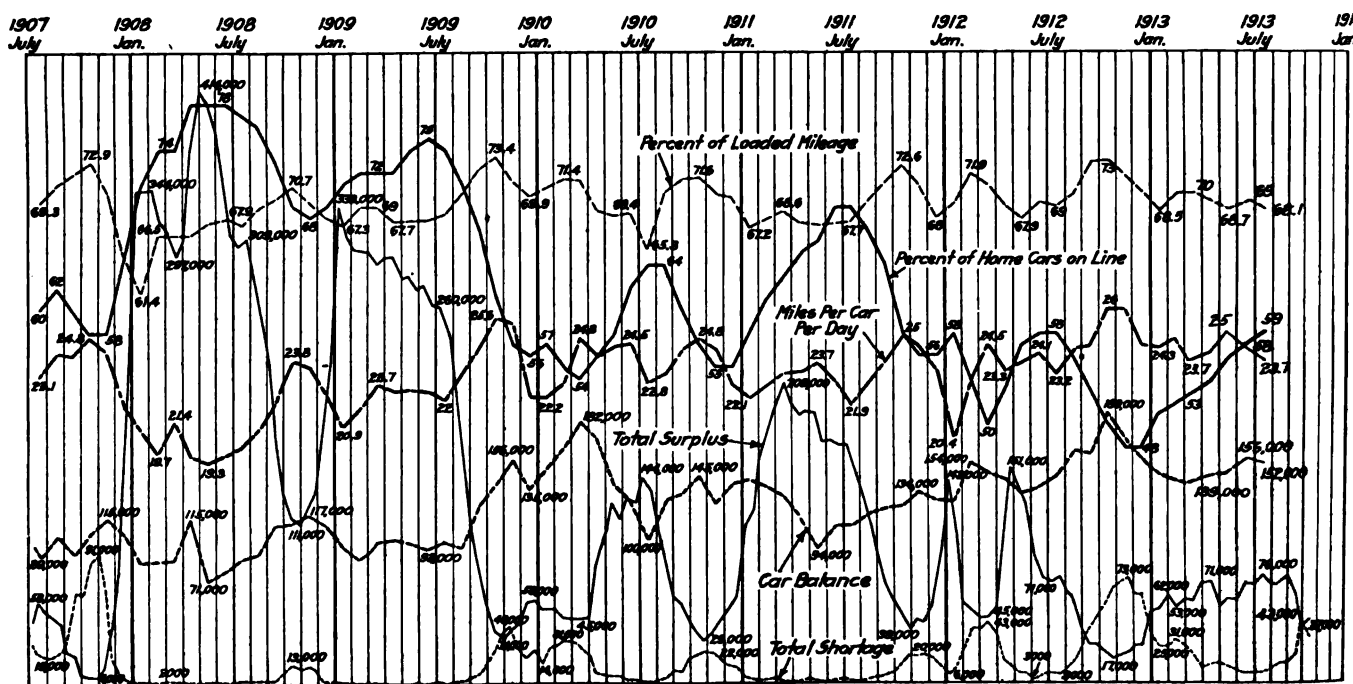
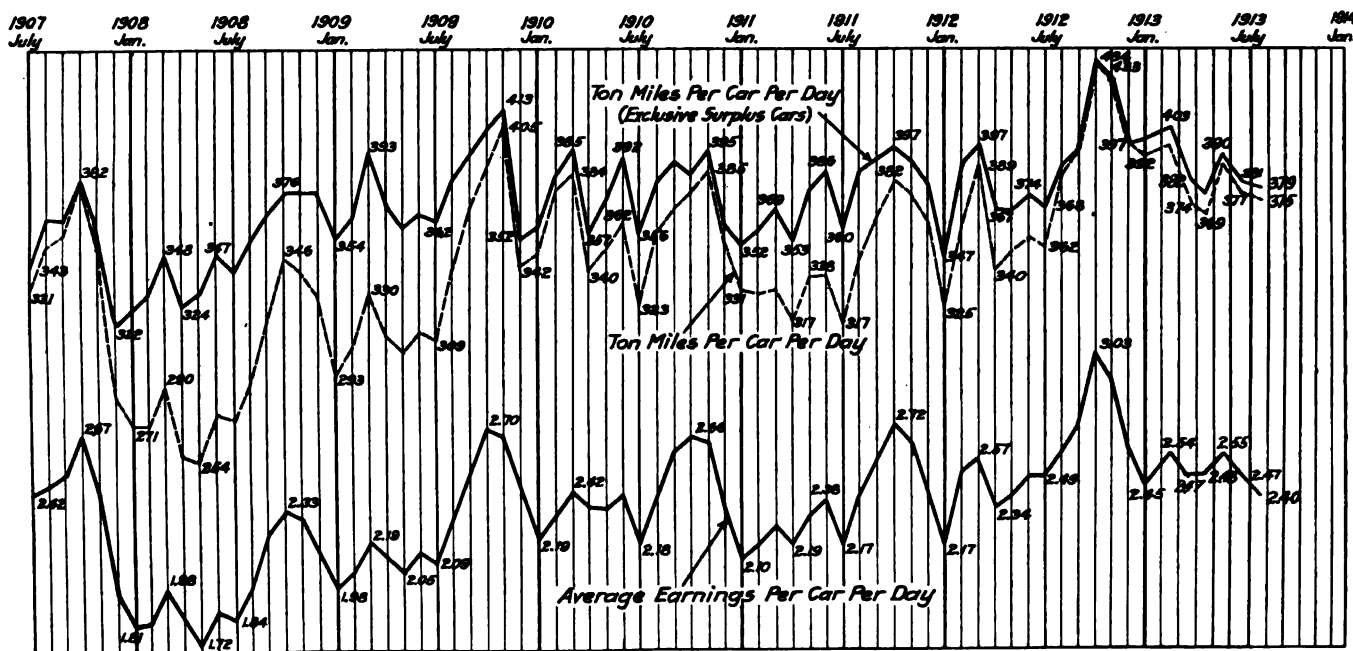

Freight Car Mileage, Earnings and Performance, 1907 to 1913.

CAR BALANCE AND PERFORMANCE IN JULY, 1913.

	N. Y., N. J., Del., Md., Eastern Pa.	Ohio, Ind., Mich., Western Pa.	Va., W. Va., No. and So. Carolina.	Ky., Tenn., Miss., Ala., Ga., Fla.	Iowa, Ill., Wis., Minn.	Mont., Wyo., Neb., Dakotas.	Kan., Colo., Okla., Mo., Ark.	Texas, La., New Mex.	Ore., Idaho, Nev., Cal., Ariz.	Canadian Lines.	Grand Total.
Revenue freight cars owned.....	90,101	201,648	189,759	162,354	418,308	17,901	146,194	19,927	137,079	161,941	2,238,686
Average number of system cars on line.....	44,239	126,167	100,370	83,045	301,491	5,824	80,379	15,494	72,191	92,495	1,315,482
Revenue freight cars: Average foreign on line.....	49,567	103,443	68,543	57,694	140,040	8,005	61,298	15,963	40,015	40,473	880,073
Total Railway-owned cars on line.....	93,806	229,610	168,913	140,739	441,531	13,829	141,877	31,457	112,206	132,968	2,193,555
Excess.....	3,705	27,962	20,866	21,615	23,223	4,072	4,317	11,530	24,873	26,973	43,131
Per cent. of cars on line to total owned:											
Home.....	49	63	53	51	72	32	55	78	47	67	159
Foreign.....	35	51	36	36	34	45	38	80	28	29	140
All railways.....	104	114	89	87	106	77	93	158	75	96	199
Private cars on line.....	3,960	9,858	4,705	8,984	14,779	1,955	9,100	2,026	12,004	2,549	104,954
Total, all cars on line.....	97,766	239,468	173,618	149,723	456,310	15,784	150,977	33,483	124,210	135,517	2,300,509
Per cent. of cars in shop.....	7.50	6.39	8.69	11.03	6.53	14.92	8.46	8.72	6.42	4.32	7.40
No. of freight engines owned.....	1,448	2,944	3,503	2,741	6,729	503	2,940	659	2,887	2,242	37,100
Average cars on line per freight engine owned.....	68	81	50	55	68	31	51	51	39	60	62
Total freight-car mileage.....	56,960,425	530,392,770	135,257,227	122,053,057	316,749,416	26,040,449	97,615,713	25,277,021	111,399,470	115,094,829	1,694,552,331
Average mileage per car per day.....	18.8	20.9	25.1	26.7	22.3	53.2	24.6	24.2	26.9	24.2	23.7
Per cent. loaded mileage.....	71.6	65.8	65.4	70.7	68.6	73.9	70.2	68.7	69.7	74.4	68.1
Ton-miles of freight, including company freight.....	668,145,666	8,821,398,185	2,252,995,396	1,747,418,728	3,576,547,506	415,801,575	1,091,290,907	346,464,174	1,626,473,887	1,963,215,271	25,265,415,658
Average ton-miles, including company freight:											
Per car-mile.....	11.7	16.6	16.7	14.5	14.7	16.0	14.0	13.8	14.8	15.9	15.8
Per loaded car-mile.....	16.4	25.3	25.5	21.4	21.4	21.6	20.0	21.3	20.0	21.4	23.2
Per car per day.....	220	393	419	386	328	850	312	339	429	385	375
Gross freight earnings.....	\$7,015,036	\$50,840,689	\$12,163,735	\$11,105,971	\$33,472,180	\$3,008,175	\$9,879,287	\$2,776,125	\$16,488,532	\$10,299,104	\$171,615,739
Average daily earnings: Per car owned.....	\$2.51	\$2.36	\$2.07	\$2.21	\$2.58	\$5.42	\$2.10	\$4.49	\$3.45	\$2.40	\$2.46
Per railroad car on line.....	2.41	2.38	2.05	2.55	2.43	7.02	2.26	2.85	4.62	2.50	2.51
All cars on line.....	2.31	2.27	1.96	2.39	2.37	6.15	2.13	2.67	4.23	2.45	2.40

\*Denotes deficiency. 123,363 cars owned eliminated in per cents.

in freight rates ever made by the railroads to any state at one time." The new rates will be put into effect as soon as the tariffs can be prepared, and the legal notice given.

But the legislature also took up the question of intrastate rates, and passed a law prescribing an entirely new tariff; and these new rates are now declared by the railroads to be unreasonably low, and confiscatory. The law provides for the appointment by the governor of a special commission to consider this complaint of the carriers and it is understood that Governor Craig will appoint this special commission this week. The new law contains 16 sections and prescribes the powers of the Corporation Commission over rates in detail. The legislature has now adjourned and the special commission has power to change the rates if they are found to be unreasonable. For the future the Corporation Commission may at any time raise the prescribed rates on roads less than 75 miles long, and, on six months' notice, may raise them on any road.

Any rate on any commodity which is lower than the new rate must be continued in force, unless raised by proper authority, as provided in the law. The Corporation Commission may regulate rates over two or more lines, and may prescribe charges for transfer of goods at junctions. Overcharges due to rates illegally excessive must be refunded within 30 days after written demand, or the carrier will be liable to double the amount of the overcharge, and to a penalty of \$10 a day for delay.

The Corporation Commission is directed to require the railroads to keep separate the cost of doing interstate and intrastate business and to keep separate the receipts from both these classes of business.

The first class rate prescribed by the law for five miles is 12 cents; 10 miles, 13.5 cents; 20 miles, 16 cents; 50 miles, 23 cents; 100 miles, 33.5 cents; 150 miles, 43.5 cents; 200 miles, 53.5 cents; 300 miles, 63 cents; 400 miles, 72.5 cents. Cotton, per 100 lbs., 10 miles, 7 cents; 50 miles, 11 cents; 100 miles, 16.5 cents; 150 miles, 21.5 cents; 200 miles, 26.5 cents; 300 miles, 34 cents; 400 miles, 36.5 cents.

INTERSTATE COMMERCE COMMISSION.

The commission has suspended from November 15 until March 12, about 21,000 tariffs which proposed to increase freight rates in official classification territory by 5 per cent. Hearings in regard to the reasonableness of the advances will be begun in Washington, D. C., on November 24.

The commission suspended from November 10 until March 10 the item in Agent F. A. Leland's tariff, which proposes to cancel the present commodity rate of 56 cents per 100 lbs. on shipments of peanuts, c. l., minimum weight 30,000 lbs., from New Orleans and certain other points in Louisiana to Oklahoma City, Okla. The proposed class rate on peanuts, c. l., minimum weight 24,000 lbs., is 90 cents per 100 lbs.

Rehearing Denied.

*John Taylor Dry Goods Co. et al. v. Missouri Pacific et al. Opinion by Commissioner Prouty:*

The commission denied the petition of the complainant for a rehearing in this case. The original decision was abstracted in the *Railway Age Gazette* of August 15, 1913, page 310. (28 I. C. C., 308.)

An Absurd Complaint Dismissed.

*Haverhill Box Board Company v. Boston & Maine, et al. Opinion by Commissioner Prouty:*

In this case the complainant asks the commission to establish a through route and through rate between Haverhill, Mass., and Boston, via Wyndham, N. H., for the movement of its traffic. Hitherto this traffic has moved from Haverhill to Boston over the direct line of the Boston & Maine. The rate on box boards between these points, 33 miles, is 7 cents per 100 lbs. The complainant seeks to have this rate reduced, but has been unsuccessful in its attempts to have it reduced over the direct line, which lies entirely in the state of Massachusetts. The commission decided that it would not be justified in compelling the defendant to establish a through rate over a long circuitous route when a short direct route was available. (28 I. C. C. 336.)

REVENUES AND EXPENSES OF RAILWAYS.

MONTH OF SEPTEMBER, 1913.

Name of road.	Average mileage operated during period.	Operating revenues.				Operating expenses.				Total.	Net operating revenue (or deficit).	Outside operations, net.	Taxes.	Operating income (or loss).	Increase (or decrease) comp. with last year.
		Freight.	Passenger.	inc. misc.	Total.	Way and structures.	equipment.	Trans- portation.	Traffic.						
Alabama & Vicksburg.....	143	\$99,944	\$41,993	\$152,813	\$27,319	\$19,272	\$27,319	\$4,182	\$53,197	\$5,855	\$109,825	\$42,988	\$7,450	\$35,299	\$2,409
Ann Arbor.....	292	1,219,930	49,796	1,833,856	24,119	22,889	24,119	4,509	63,075	6,377	120,597	63,287	12,930	49,267	6,179
Arizona & New Mexico.....	109	67,878	9,450	81,396	9,432	9,432	9,432	871	16,122	3,131	39,146	42,250	3,408	34,830	3,398
Atchison, Topeka & Santa Fe.....	8,357	5,451,705	2,107,128	8,147,733	1,380,851	1,177,184	1,380,851	17,420	2,199,281	185,011	5,119,731	3,027,982	376,189	2,651,793	4,607
Atlanta & West Point.....	93	56,601	42,000	108,686	14,116	22,509	14,116	4,996	32,364	4,790	78,775	29,911	6,484	23,824	3,330
Atlanta, Birmingham & Atlantic.....	645	209,815	54,514	287,091	47,912	45,965	47,912	14,339	107,928	11,209	227,353	59,738	14,337	45,401	5,682
Atlantic Coast Line.....	4,618	1,788,589	667,987	2,642,406	432,338	480,622	432,338	45,510	968,797	105,320	2,032,587	470,819	132,008	1,700,581	5,233
Baltimore & Ohio Chicago Terminal.....	77	152,830	782	153,612	20,271	22,321	20,271	736	64,050	5,111	112,489	40,341	16,052	24,185	4,021
Bangor & Aroostook.....	631	234,754	74,384	322,658	34,504	45,981	34,504	2,483	102,523	11,774	197,274	125,384	9,758	117,626	33,468
Balt Ry. Co. of Chicago.....	21	.....	.....	241,328	25,429	32,243	25,429	572	96,283	6,758	161,285	80,043	.....	70,356	24,473
Bessemer & Lake Erie.....	204	948,636	49,017	1,010,887	82,523	207,619	82,523	7,838	226,268	11,922	536,170	473,917	38,009	431,817	18,014
Birmingham Southern.....	33	63,496	8,888	106,232	14,503	12,547	14,503	544	36,323	4,412	86,239	37,993	1,805	34,188	1,048
Buffalo & Susquehanna Railroad.....	252	134,515	8,810	147,346	31,599	21,164	31,599	1,808	50,933	5,634	110,938	36,408	2,208	34,208	3,498
Buffalo & Susquehanna Ry.....	91	35,142	10,642	48,626	30,802	30,802	30,802	571	20,802	2,564	67,065	18,439	1,600	28,036	1,813
Buffalo, Rochester & Pittsburgh.....	576	901,737	108,013	1,047,263	139,431	194,998	139,431	12,281	334,684	19,678	701,072	346,193	18,000	228,089	51,039
Carolina, Clinchfield & Ohio.....	248	208,478	19,416	234,323	17,430	27,156	17,430	7,771	41,017	8,701	102,075	132,248	9,250	122,998	19,833
Carolina, Clinch. & Ohio Ry. Co. of S. C.....	18	11,659	1,384	13,511	1,536	1,536	1,536	1,578	2,467	904	5,585	7,826	.....	7,176	1,036
Central of Georgia.....	1,924	835,731	307,277	1,235,962	150,201	233,522	150,201	34,557	406,277	37,875	862,942	377,020	50,466	333,169	10,181
Central of New Jersey.....	676	1,798,782	512,442	2,410,971	285,069	387,356	285,069	31,224	727,683	42,747	1,464,039	946,912	111,118	828,350	43,340
Central New England.....	304	277,353	47,959	340,245	54,179	38,756	54,179	1,410	86,004	5,227	185,556	154,689	10,500	144,388	38,469
Charleston & Western Carolina.....	341	1,26,280	30,552	164,313	34,312	32,807	34,312	3,387	60,875	4,240	135,621	28,692	5,000	23,692	4,534
Chesapeake & Ohio Lines.....	2,343	3,774,400	611,075	3,122,153	364,528	610,752	364,528	53,860	962,299	70,481	2,061,873	1,060,280	109,960	952,699	69,549
Chicago & Alton.....	1,032	910,887	383,793	1,389,990	173,123	280,383	173,123	38,321	488,117	36,146	1,016,090	373,900	40,600	330,804	37,343
Chicago & Erie.....	270	381,812	65,475	445,722	110,641	88,572	110,641	20,152	227,237	11,923	488,578	2,856	16,029	24,428	5,477
Chicago & North Western.....	8,003	5,123,043	2,103,417	7,868,878	1,120,324	1,098,278	1,120,324	116,232	2,707,328	138,856	5,181,018	2,687,860	320,000	2,377,336	42,611
Chicago, Burlington & Quincy.....	9,129	6,012,719	2,199,834	8,972,118	1,145,404	1,378,387	1,145,404	136,759	2,621,071	211,185	5,492,806	3,479,312	304,275	3,165,261	271,396
Chicago, Great Western.....	1,496	943,425	327,207	1,367,014	237,686	201,522	237,686	51,460	432,939	35,430	959,307	407,977	38,650	369,926	1,804
Chicago, Indiana & Southern.....	359	306,605	31,884	350,566	64,022	110,135	64,022	8,433	117,480	10,186	210,256	40,310	11,282	25,982	37,872
Chicago Junction.....	12	.....	.....	140,848	24,524	4,208	24,524	3,597	124,306	12,548	58,994	6,604	2,548	58,994	8,604
Chicago, Peoria, & St. Louis.....	255	106,319	25,458	185,838	28,715	36,972	28,715	6,999	69,884	5,167	147,737	6,899	4,800	11,699	23,368
Chicago, Rock Island & Gulf.....	477	159,776	57,449	234,948	23,535	42,812	23,535	10,123	86,355	7,695	170,520	64,428	12,220	51,264	31,996
Chicago, Rock Island & Pacific.....	7,525	3,746,950	1,820,994	5,931,949	757,134	824,198	757,134	156,085	2,227,788	156,085	4,125,163	1,806,786	284,365	1,505,618	31,694
Chicago, St. Paul, Minneapolis & Omaha.....	1,747	1,061,822	365,962	1,717,426	141,441	184,773	141,441	28,926	587,753	34,993	1,152,886	564,540	81,568	487,367	3,694
Chicago, Terre Haute & Southeastern.....	1,462	175,224	17,123	196,740	29,636	37,820	29,636	3,606	58,785	7,863	157,510	39,230	11,500	27,338	9,850
Cincinnati, Hamilton & Dayton.....	1,015	661,920	168,804	930,970	156,343	145,008	156,343	25,589	412,788	20,126	759,834	171,116	34,713	136,403	12,563
Cincinnati Northern.....	245	115,105	22,503	143,437	29,546	34,451	29,546	3,023	59,246	3,683	129,939	13,498	5,500	7,998	18,640
Cincinnati, Chic. & St. Louis.....	2,014	2,019,439	814,993	3,086,916	398,858	801,671	398,858	80,171	1,233,215	57,526	2,556,414	530,502	103,800	429,276	12,199
Colorado Midland.....	338	1,611,020	29,484	2,015,999	29,774	36,140	29,774	8,423	81,730	6,086	1,621,153	39,446	8,000	31,146	39,159
Cumberland Valley.....	162	236,473	65,236	315,574	74,218	31,733	74,218	4,479	100,910	9,065	222,405	93,269	5,702	87,820	28,627
Delaware, Lackawanna & Western.....	959	2,550,463	827,598	3,602,292	482,913	543,584	482,913	76,793	1,046,166	63,683	2,213,139	1,389,153	165,000	1,247,261	49,854
Denver & Salt Lake.....	215	94,278	36,311	136,864	17,083	14,789	17,083	2,274	37,675	3,298	75,119	61,745	4,000	57,745	12,199
Detroit & Mackinac.....	411	64,325	30,845	101,797	15,394	17,684	15,394	2,046	37,073	2,862	75,061	26,736	8,379	18,357	10,548
Detroit River Tunnel.....	2	.....	.....	4,794	4,794	4,794	4,794	.....	.....	38	18,036	8,550	6,000	77,560	3,694
Detroit, Toledo & Ironton.....	441	101,375	14,433	126,086	28,822	69,321	28,822	2,573	72,072	5,843	178,631	52,945	5,700	58,245	96,849
Duluth & Iron Range.....	272	971,857	223,699	1,003,378	90,899	83,382	90,899	892	188,323	15,086	378,582	74,796	55,384	573,251	1,833
Duluth, Missabe & Northern.....	356	1,240,391	33,106	1,283,233	97,345	89,819	97,345	2,270	195,136	12,827	397,097	886,136	73,877	816,398	77,582
El Paso & Southwestern Co.....	982	554,913	90,192	676,368	138,144	189,101	138,144	15,481	189,101	26,951	467,162	209,206	35,000	174,421	99,748
Elgin, Joliet & Eastern.....	803	1,091,519	886,197	1,161,537	175,437	175,437	175,437	5,426	313,059	17,181	726,852	433,685	162,364	400,835	35,406
Erie.....	1,988	3,421,319	886,197	4,648,481	670,353	866,372	670,353	106,134	1,553,570	101,221	3,297,650	1,350,631	162,364	1,149,693	339,513
Florence & Cripple Creek.....	87	86,536	20,054	108,808	14,692	10,009	14,692	2,108	27,703	4,159	58,671	50,137	1,679	48,458	3,685
Grand Rapids & Indiana.....	395	121,381	74,566	216,446	26,295	41,913	26,295	7,475	84,557	9,677	169,917	46,529	20,658	35,871	11,410
Grand Rapids & Michigan.....	578	281,973	227,589	545,013	67,546	69,792	67,546	11,977	210,205	14,922	374,442	170,571	23,641	146,347	1,968
Gulf & Ship Island.....	308	139,123	34,601	183,894	20,636	32,443	20,636	3,006	45,467	8,227	109,779	74,115	7,050	67,065	22,257
Gulf Colorado & Santa Fe.....	1,596	872,599	251,468	1,192,824	185,616	184,400	185,616	26,421	422,734	31,145	850,210	342,608	55,681	286,927	136,199
Illinois Central.....	4,763	3,845,625	1,242,348	5,812,253	871,768	1,069,935	871,768	106,935	1,971,939	121,796	4,421,371	1,390,882	1,264	1,128,146	83,241
Indiana Harbor Belt.....	105	301,487	38,377	377,415	47,776	40,745	47,776	3,530	128,043	7,766	227,860	45,555	6,000	44,694	44,216
Kanawha & Michigan.....	177	256,256	38,377	301,487	45,847	67,118	45,847	2,348	83,263	6,550	205,126	96,361	9,433	86,989	16,017
Kansas City Southern.....	827	679,153	145,885	878,644	80,635	111,606	80,635	28,623	284,132	33,019	538,013	340,529	40,013	300,616	44,238
Lake Erie & Western.....	906	437,805	86,446	556,516	93,614	112,058	93,								

REVENUES AND EXPENSES OF RAILWAYS.

MONTH OF SEPTEMBER, 1913.—CONTINUED.

Table with columns: Name of road, Average mileage operated during period, Operating revenues (Freight, Passenger, inc. misc.), Maintenance (Total, Way and structures, Of equipment), Operating expenses (Traffic, Transportation, General), Net operating revenue (Total, (or deficit)), Outside operations, net, Taxes, Operating income (or loss), Increase (or decrease) comp. with last year.



REVENUES AND EXPENSES OF RAILWAYS.

THREE MONTHS OF FISCAL YEAR, 1914.

Name of road.	Average mileage operated during period.	Operating revenues				Operating expenses				Net operating revenue (or deficit).	Outside operations, net.	Taxes.	Operating income (or loss).	Increase (or decr.) comp. with last year.
		Freight.	Passenger.	Total, inc. misc.	Total.	Way and structures.	Maintenance of equipment.	Traffic.	Trans- portation.					
Alabama & Vicksburg.....	143	\$281,854	\$133,765	\$449,674	\$64,960	\$95,611	\$11,630	\$159,987	\$17,274	\$449,462	-\$2,063	\$23,350	\$75,799	-\$25,393
Ann Arbor.....	292	347,090	176,298	523,388	121,666	191,519	164,936	326,875	19,539	523,414	153	11,790	154,077	7,178
Arizona & New Mexico.....	106	206,974	27,078	234,052	32,544	29,321	2,232	34,776	8,623	43,400	.....	10,200	151,481	41,883
Atchafalaya & Santa Fe.....	8,357	15,706,391	6,532,346	23,983,236	3,705,457	4,234,033	514,904	6,532,497	54,662	15,560,759	8,426,497	1,127,076	7,295,421	27,720
Atlanta & West Point.....	93	146,187	101,252	304,659	48,246	63,439	15,281	93,573	14,106	258,625	752	19,453	47,373	-15,274
Atlanta, Birmingham & Atlantic.....	645	555,551	185,494	803,911	132,298	145,541	41,899	315,668	32,615	669,021	134,890	43,011	91,879	20,148
Atlantic Coast Line.....	4,618	4,852,610	2,048,087	7,431,274	1,284,470	1,410,460	145,282	2,914,377	291,537	6,044,606	1,386,668	396,000	990,668	-259,979
Baltimore & Ohio Chicago Terminal.....	77	.....	2,636	462,178	62,799	61,269	2,282	201,424	14,939	342,473	119,703	48,135	74,521	7,831
Bangor & Aroostook.....	631	524,448	199,672	765,571	121,476	128,421	7,578	264,146	32,871	554,492	211,079	29,273	282,266	-8,008
Belt Ry. Co. of Chicago.....	21	.....	.....	753,892	67,473	98,884	294,745	1,659	482,135	271,757	.....	29,213	182,504	-50,729
Bessemer & Lake Erie.....	204	2,944,552	157,034	3,138,698	262,874	508,937	29,976	679,320	33,763	1,514,870	1,623,828	114,000	1,509,828	-51,470
Birmingham Southern.....	43	201,649	3,227	336,856	46,011	39,488	1,608	110,528	12,932	210,567	126,289	5,415	170,888	27,433
Buffalo & Susquehanna Railroad.....	252	414,956	28,359	455,142	88,586	67,801	4,173	152,513	17,581	330,654	124,488	6,600	117,858	10,182
Buffalo & Susquehanna Ry.....	91	114,688	38,699	162,507	33,412	84,742	1,500	64,181	8,285	192,120	-29,613	4,800	316,428	-14,455
Buffalo, Rochester & Pittsburgh.....	576	2,704,861	379,746	3,204,033	462,677	586,747	37,304	1,023,976	59,651	2,170,295	1,033,738	54,000	980,192	108,631
Carolina, Clinchfield & Ohio.....	248	626,599	66,753	709,629	49,903	78,787	21,011	124,198	25,851	299,750	409,879	27,750	382,129	41,249
Carolina, Clinch & Ohio Ry. Co. of S. C.....	18	33,903	5,600	40,335	1,755	264	4,258	7,449	1,643	15,369	24,966	2,250	22,716	5,246
Central of Georgia.....	1,924	1,990,678	1,007,231	3,248,044	486,885	717,158	103,738	1,153,492	116,141	2,577,414	670,630	151,206	540,937	-218,708
Central New Jersey.....	676	5,224,040	1,815,413	7,303,272	786,446	1,110,722	105,007	2,174,870	130,978	4,308,023	2,995,254	316,428	2,850,256	-393,962
Central New England.....	304	767,605	123,417	929,890	149,864	103,678	3,564	241,449	16,140	514,695	415,195	31,500	384,537	-101,111
Charleston & Western Carolina.....	341	346,514	99,038	466,010	95,274	83,888	9,870	180,501	13,079	382,612	83,398	15,000	68,398	31,652
Cheapeake & Ohio Lines.....	2,343	7,018,819	1,804,242	9,228,672	1,098,737	1,746,789	164,962	2,872,016	222,178	6,104,882	3,123,990	323,880	2,797,995	5,246
Chicago & Alton.....	1,032	2,670,894	1,237,627	4,916,629	523,873	796,702	116,631	1,450,534	104,715	2,992,855	1,198,774	118,600	1,072,777	66,983
Chicago & Erie.....	270	1,074,011	203,576	1,402,605	335,298	343,473	63,754	692,634	35,803	1,431,962	-29,357	41,819	96,101	-142,100
Chicago & North Western.....	8,003	14,687,582	6,336,715	22,992,536	3,834,376	3,210,308	371,711	8,070,078	422,374	15,908,867	7,083,669	960,000	6,132,502	-115,502
Chicago, Burlington & Quincy.....	9,129	16,990,146	6,660,578	25,786,645	3,445,264	4,222,030	430,617	7,555,822	497,021	16,150,754	9,635,891	13,825	8,686,076	205,491
Chicago Great Western.....	1,496	2,611,284	979,753	3,870,490	592,979	678,653	151,793	1,279,808	106,469	2,709,704	1,156,786	119,951	1,067,311	83,903
Chicago, Indiana & Southern.....	359	902,768	96,342	1,032,861	170,463	311,797	22,311	150,866	31,323	306,560	146,704	45,848	83,627	-84,687
Chicago Junction.....	12	.....	.....	535,914	59,483	71,269	3,472	263,638	10,864	354,626	181,288	17,622	173,666	11,514
Chicago, Peoria & St. Louis.....	255	294,797	97,093	416,699	77,035	99,693	20,280	192,375	15,226	405,179	11,520	14,400	-2,880	-54,218
Chicago, Rock Island & Gulf.....	477	483,985	178,194	717,566	88,937	119,994	30,514	272,149	23,375	534,289	183,277	23,089	151,571	-61,724
Chicago, Rock Island & Pacific.....	7,525	11,000,221	5,493,944	17,568,704	2,695,130	2,610,819	480,888	6,704,270	453,308	12,944,415	4,624,289	44,402	3,744,288	-818,855
Chicago, St. Paul, Minneapolis & Omaha.....	1,747	2,777,725	1,568,644	4,688,210	902,815	1,268,006	88,810	1,677,248	101,684	3,338,533	1,299,677	228,149	1,083,856	-24,563
Chicago, Terre Haute & Southeastern.....	362	452,762	57,202	522,500	90,433	126,304	9,470	287,538	24,652	408,369	113,931	34,500	78,488	4,851
Cincinnati, Hamilton & Dayton.....	1,015	1,948,857	522,275	2,782,995	437,763	438,817	68,122	1,249,640	60,353	2,254,697	528,298	104,137	424,161	-37,130
Cincinnati Northern.....	245	296,476	79,720	394,815	84,027	111,738	8,104	167,591	10,415	381,875	12,940	16,500	-3,560	-70,335
Cleveland, Cincinnati, Chic. & St. Louis.....	2,014	6,006,497	2,562,801	9,348,331	1,505,029	2,375,660	223,886	3,749,805	185,270	8,039,600	1,308,731	311,400	1,004,507	-518,186
Colorado Midland.....	338	368,197	103,535	500,326	104,980	111,499	26,067	210,449	17,392	470,387	29,939	24,000	5,013	-59,687
Cumberland Valley.....	162	651,346	210,474	900,172	206,809	87,951	14,802	287,538	24,652	621,752	278,420	17,107	261,674	-42,074
Delaware, Lackawanna & Western.....	959	7,523,553	2,589,381	10,788,119	1,608,200	1,622,300	221,138	3,107,091	199,403	6,758,132	4,029,987	93,823	3,628,810	-43,694
Denver & Salt Lake.....	215	227,296	183,945	431,914	63,139	50,432	10,122	107,441	11,707	242,841	189,073	12,000	177,073	41,738
Detroit & Mackinac.....	411	203,861	105,393	330,367	40,748	45,498	17,176	116,447	7,865	217,734	112,633	25,279	88,649	8,277
Detroit, Toledo & Ironton.....	441	327,642	47,045	408,279	115,028	180,687	7,452	226,523	17,012	546,702	-138,423	17,100	-155,233	-249,445
Detroit River Tunnel.....	2	.....	.....	10,678	10,371	10,678	.....	26,628	112	47,789	268,307	18,000	250,307	19,888
Duluth & Iron Range.....	272	3,274,343	74,722	3,378,560	305,319	231,836	3,750	637,603	38,434	1,216,942	2,161,618	184,816	2,000,140	98,802
Duluth, Missabe & Northern.....	356	3,732,929	1,024,896	3,866,836	309,736	296,936	7,221	581,530	80,046	1,429,913	2,636,928	221,021	2,432,863	-351,554
El Paso & Southwestern Co.....	982	1,664,310	292,779	2,047,293	382,185	297,964	45,972	1,376,795	34,046	1,376,795	670,498	105,000	562,693	-233,931
Elgin, Joliet & Eastern.....	803	3,184,361	1,212,382	4,400,919	540,099	631,697	15,297	923,532	55,073	2,165,698	1,236,358	89,150	1,407,208	-343,233
Erie.....	1,988	10,213,982	2,964,184	14,241,136	1,992,851	2,502,251	316,206	4,588,617	323,539	9,723,284	4,517,852	439,457	4,004,287	-846,922
Florence & Cripple Creek.....	87	258,270	94,039	358,850	50,315	27,867	7,487	88,331	12,363	186,363	172,842	5,291	167,196	12,850
Grand Rapids & Indiana.....	395	328,118	207,201	602,047	78,398	124,633	23,624	254,375	28,478	509,508	92,539	31,971	60,566	-17,140
Grand Rapids & Michigan.....	578	772,381	171,928	1,602,078	218,466	219,985	35,689	641,840	47,718	1,167,698	434,380	70,202	365,581	-49,084
Gulf & Ship Island.....	308	399,055	118,889	550,671	62,851	90,001	8,252	136,977	24,358	322,439	228,232	21,461	206,971	52,518
Gulf, Colorado & Santa Fe.....	1,596	2,429,962	869,930	3,496,565	612,708	529,661	78,419	1,270,032	94,054	2,614,964	881,601	153,425	728,176	-237,196
Illinois Central.....	4,763	10,891,196	3,752,673	16,776,696	2,602,638	3,862,533	314,099	5,918,225	393,529	13,090,344	3,686,152	792,000	2,888,431	-306,243
Indiana Harbor Belt.....	103	.....	.....	825,513	138,193	162,509	9,024	376,852	22,728	649,308	176,607	16,500	168,748	-88,483
Kanawha & Michigan.....	177	788,319	109,345	917,594	136,678	189,106	7,866	251,282	20,509	605,441	312,100	28,439	283,675	-63,181
Kansas City Southern.....	827	1,881,338	472,905	2,608,078	344,831	344,831	81,567	848,227	98,492	1,603,267	1,002,811	120,039	882,770	-57,245
Lake Erie & Western.....	906	1,232,924	273,587	1,599,040	282,820	343,916	33,929	592,146	36,805	1,289,614	300,436	66,457	262,074	-15,613
Lake Shore & Michigan Southern.....	1,872	9,505,059	4,044,711	15,187,265	2,897,022	2,897,022	277,409	4,820,115	283,331	10,476,669	4,691,577	450,000		

REVENUES AND EXPENSES OF RAILWAYS.

THREE MONTHS OF FISCAL YEAR, 1914—CONTINUED.

Name of road.	Average mileage operated during period.	Operating revenues				Operating expenses				Net operating revenue (or deficit).	Outside operations, net.	Taxes.	Operating income (or loss).	Increase (or decr.) comp. with last year.
		Freight.	Passenger.	inc.	Total.	Way and structures.	Maintenance of equipment.	Traffic.	Transp.					
Lehigh & New England.....	269	\$422,523	\$4,597	\$439,479	\$63,055	\$4,395	\$10,207	\$257,338	\$10,207	\$10,207	\$9,536	\$172,605	\$35,465	
Lehigh Valley.....	1,438	874,423	1,852,213	10,705,994	1,752,734	285,924	206,485	7,019,132	206,485	7,019,132	363,000	3,235,351	178,703	
Long Island.....	399	808,592	2,621,767	4,055,122	425,544	66,913	81,913	2,377,322	81,913	2,377,322	190,980	1,477,808	1,285,763	
Louisiana Ry. & Navigation.....	351	382,679	79,989	492,653	95,864	20,178	10,936	391,726	10,936	391,726	16,500	84,427	44,710	
Louisville & Nashville.....	4,923	10,791,576	3,650,346	15,310,985	2,506,086	311,051	311,338	11,383,832	311,338	11,383,832	451,825	3,475,539	98,091	
Louisville, Henderson & St. Louis.....	200	215,241	117,325	352,772	42,603	111,147	16,822	246,184	16,822	246,184	10,800	96,392	59,257	
Maine Central.....	1,207	1,710,829	1,223,537	3,126,637	545,959	39,542	78,488	2,255,807	78,488	2,255,807	141,292	740,804	114,176	
Michigan Central.....	1,819	5,418,166	2,924,628	9,193,734	1,564,238	206,154	159,132	7,134,800	159,132	7,134,800	346,000	1,710,091	704,107	
Midland Valley.....	373	278,984	120,453	420,725	89,138	7,612	18,112	341,677	18,112	341,677	17,960	61,181	121	
Minneapolis & St. Louis.....	1,586	1,724,945	593,195	2,466,978	339,429	52,127	58,654	1,655,996	58,654	1,655,996	97,444	713,480	20,267	
Missouri & North Arkansas.....	365	202,400	127,764	348,933	78,997	10,570	16,822	222,507	16,822	222,507	16,500	47,073	54,740	
Missouri, Okla. & Gulf Ry. Co. of Texas.....	19	22,913	1,600	24,930	2,747	545	1,796	26,028	1,796	26,028	514	1,612	232	
Missouri Pacific.....	3,920	5,614,000	1,414,092	7,628,142	1,167,166	142,121	210,926	5,938,561	210,926	5,938,561	280,170	1,396,721	119,152	
Mobile & Ohio.....	1,122	2,599,572	403,652	3,176,558	628,815	114,580	92,590	2,401,003	92,590	2,401,003	98,434	673,426	3,326	
Monongahela.....	67	388,020	8,792	402,697	55,821	1,068	6,437	164,320	6,437	164,320	7,050	231,327	26,613	
Monongahela Connecting.....	6	2,072,300	851,091	2,733,615	36,710	900	7,691	222,507	7,691	222,507	8,126	42,982	49,182	
Nashville, Chattanooga & St. Louis.....	1,231	389,252	172,581	422,928	52,521	126,975	90,574	2,584,980	90,574	2,584,980	76,020	507,499	143,837	
Nevada Northern.....	165	786,194	106,205	478,669	66,362	8,656	21,457	280,515	21,457	280,515	7,001	190,856	35,464	
New Orleans & North Eastern.....	283	335,479	106,205	478,669	66,362	8,656	21,457	280,515	21,457	280,515	7,001	190,856	35,464	
New Orleans Great Northern.....	403	409,586	101,504	544,394	53,688	10,928	22,111	337,492	22,111	337,492	20,071	186,487	22,603	
New Orleans, Mobile & Chicago.....	2,093	8,371,090	7,925,769	17,957,727	2,379,214	142,311	436,816	12,027,130	436,816	12,027,130	920,000	5,032,044	1,884,229	
New York, New Haven & Hartford.....	154	496,646	159,851	738,047	122,353	5,918	24,922	550,443	24,922	550,443	49,267	144,977	257	
New York, Susquehanna & Western.....	2,035	9,989,248	1,430,255	11,839,884	1,527,737	171,299	218,570	7,903,690	218,570	7,903,690	375,000	3,555,141	203,602	
Norfolk & Western.....	2,035	9,989,248	1,430,255	11,839,884	1,527,737	171,299	218,570	7,903,690	218,570	7,903,690	375,000	3,555,141	203,602	
Northern Central.....	472	2,539,806	755,219	3,510,508	481,759	55,081	86,380	2,993,999	86,380	2,993,999	125,491	393,720	191,009	
Northern Pacific.....	6,312	12,977,574	5,051,209	19,242,713	2,246,330	340,028	253,045	11,907,526	253,045	11,907,526	1,069,898	6,414,302	137,687	
Northwestern Pacific.....	401	453,160	681,583	1,203,239	186,706	13,194	36,421	669,750	36,421	669,750	45,300	490,166	19,911	
Oregon Short Line.....	2,023	4,125,802	1,326,982	6,003,654	786,707	132,778	135,424	3,171,334	135,424	3,171,334	752,520	2,426,037	462,472	
Pennsylvania R.R.....	1,731	13,962,040	3,012,954	18,653,176	2,439,732	242,881	86,326	9,950,733	86,326	9,950,733	357,257	2,186,469	408,879	
Pennsylvania Railroad.....	4,032	34,662,353	10,957,974	48,824,488	6,080,405	713,044	1,121,778	34,572,423	713,044	34,572,423	1,850,628	11,688,293	603,623	
Peoria & Eastern.....	352	617,884	202,816	897,277	135,576	15,376	335,883	731,787	15,376	731,787	31,200	134,290	149,328	
Pere Marquette.....	2,325	2,586,562	1,341,750	4,326,976	852,047	100,471	178,637	3,682,439	178,637	3,682,439	149,375	477,274	584,055	
Philadelphia, Baltimore & Washington.....	713	2,777,615	2,240,713	5,166,684	916,068	114,807	152,136	4,502,284	152,136	4,502,284	164,883	849,777	354,595	
Pittsburgh & Lake Erie.....	223	4,472,703	555,334	5,213,647	706,233	42,281	1,208,412	86,326	42,281	86,326	171,000	2,186,469	408,879	
Pittsburgh, Cincinnati, Chic. & St. Louis.....	1,472	8,055,345	2,575,728	11,865,833	1,806,253	224,070	226,877	8,936,366	226,877	8,936,366	444,757	2,483,946	577,070	
Pittsburgh, Shawmut & Northern.....	282	502,586	35,576	545,572	142,769	4,594	14,971	498,132	14,971	498,132	5,470	41,970	69,889	
Richmond, Fredericksburg & Potomac.....	88	346,239	234,784	663,284	80,444	10,029	20,793	442,210	20,793	442,210	23,727	195,821	40,039	
Rutland.....	463	509,709	419,654	1,072,594	114,807	30,121	373,698	740,756	373,698	740,756	51,310	280,839	20,079	
St. Joseph & Grand Island.....	319	303,176	99,659	437,679	60,424	15,082	18,912	357,370	18,912	357,370	18,763	61,464	14,058	
St. Louis & San Francisco.....	4,742	7,651,383	3,037,767	11,440,166	1,588,706	219,553	267,088	7,521,412	267,088	7,521,412	362,282	3,556,472	321,342	
St. Louis, Brownsville & Mexico.....	518	371,894	238,002	673,357	104,382	13,953	30,858	444,514	30,858	444,514	16,500	212,341	62,856	
St. Louis, Iron Mountain & Southern.....	3,365	6,074,997	1,655,530	8,298,738	1,187,676	164,514	212,266	5,585,074	212,266	5,585,074	291,855	2,410,744	154,138	
St. Louis, San Francisco & Texas.....	244	290,550	105,303	420,938	71,186	7,504	16,592	286,161	16,592	286,161	3,675	130,562	58,048	
St. Louis Southwestern.....	906	1,562,799	395,211	2,072,719	200,825	81,836	485,857	1,222,984	485,857	1,222,984	90,696	754,518	24,656	
San Antonio & Aransas Pass.....	724	969,746	432,081	1,470,151	219,524	205,207	33,875	971,079	33,875	971,079	36,000	643,072	97,595	
Seaboard.....	3,082	3,611,977	1,300,959	5,494,952	685,107	191,043	171,471	3,939,205	171,471	3,939,205	246,000	1,305,628	160,472	
Southern in Mississippi.....	281	147,220	96,663	266,110	76,154	6,871	125,984	233,226	125,984	233,226	20,436	77,252	12,229	
Southern Kansas.....	179	244,789	52,115	313,089	39,591	6,394	10,623	207,619	10,623	207,619	12,421	93,049	52,642	
Tennessee Central.....	294	291,851	127,714	443,019	85,269	17,366	145,916	308,943	145,916	308,943	12,756	121,340	24,198	
Toledo & Ohio Central.....	443	1,453,726	204,033	1,764,365	300,134	312,979	29,838	1,301,799	29,838	1,301,799	59,731	400,984	3,163	
Toledo, Peoria & Western.....	248	199,372	135,465	334,837	86,274	7,310	148,344	329,878	148,344	329,878	15,000	19,240	32,972	
Toledo, St. Louis & Western.....	451	1,013,111	123,305	1,208,736	127,583	47,239	26,349	778,472	47,239	778,472	46,000	384,266	135,072	
Trinity & Brazos Valley.....	463	424,005	163,210	609,421	156,063	31,951	34,891	618,951	34,891	618,951	14,995	24,525	99,206	
Union Railroad of Baltimore.....	9	362,961	73,715	441,155	30,822	3,913	7,592	58,955	7,592	58,955	17,553	364,647	21,751	
Union Railroad of Pennsylvania.....	31	248,998	115,886	437,793	78,794	10,427	14,999	340,501	14,999	340,501	31,000	443,566	179,379	
Vicksburg, Shreveport & Pacific.....	171	166,998	115,886	437,793	78,794	10,427	14,999	340,501	14,999	340,501	23,400	73,685	52,106	
Washington Southern.....	36	106,541	116,576	299,217	42,067	3,779	122,417	191,567	3,779	191,567	10,559	68,543	22,074	
West Jersey & Seashore.....	356	512,694	1,861,249	2,510,983	323,969	57,977	81,757	1,565,807	81,757	1,565,807	82,212	850,666	103,546	
Western Ry. of Alabama.....	433	178,848	138,326	343,702	63,485	74,218	16,540	270,521	16,540	270,521	14,515	59,089	7,820	
Wheeling & Lake Erie.....	459	2,064,868	204,280	2,479,063	475,142	436,258	52,605	1,698,839	436,258	1,698,839	91,721	581,990	202,063	
Yazoo & Mississippi Valley.....	1,372	1,839,849	675,293	2,704,093	503,172	47,417	1,053,529	2,185,627	47,417	2,185,627	129,000	386,432	207,342	

## STATE COMMISSIONS.

The Minneapolis & Rainy River has filed with the Minnesota Railroad and Warehouse Commission a petition asking to be allowed to advance its freight rates 20 per cent. above the state rates, on the ground that the latter, as applied to this road, are confiscatory.

Richard Yates, formerly governor of Illinois, has been appointed a member of the Illinois Railroad and Warehouse Commission, succeeding B. A. Edhart, with the understanding that he is to be appointed later a member of the new public utilities commission, which will succeed the present commission on January 1.

The Railroad Commission of Louisiana has announced a hearing on November 19 on a proposed order prescribing a maximum passenger fare of 2½ cents a mile for railways over 50 miles in length, and varying rates for shorter roads. The commission will also take up at the hearing the entire question of passenger fares, including a proposed rule permitting carriers to collect one cent a mile additional up to 50 miles when a passenger fails to provide himself with a ticket at a station where tickets are on sale.

The Illinois Railroad and Warehouse Commission held a hearing on November 6 on tariffs filed by the railways for a 5 per cent. advance in intrastate freight rates to correspond with the interstate rates filed with the Interstate Commerce Commission. Chairman Berry, of the commission, announced that the tariffs would be suspended for the same period of suspension as decided on by the federal commission, and if that body failed to suspend the interstate rates the Illinois commission would suspend the Illinois rates for 60 days, pending an inquiry.

## COURT NEWS.

The Supreme Court of the United States, in the case of Oliver Letot, a Texas farmer, has sustained the law of that state making railroads responsible for damage if they permit weeds to grow on their right of way and the seeds blow into adjoining farms and damage the land.

The Supreme Court of the United States, in a case against the Missouri, Kansas & Texas, has sustained the Federal hours-of-service law under which the ordinary limit for trainmen is 16 hours; and it is declared that a company is liable for a penalty in the case of each individual trainman who is required to work longer than the law allows.

## Low Lemon Rates Sustained.

The decision of the Supreme Court of the United States in the case involving freight rates on lemons from California eastward, briefly announced last week, was not accompanied by a written opinion. The court announced that the decree of the lower court, sustaining the order of the commission reducing rates, was affirmed on the authority of the case of the Illinois Central against the commission (206 U. S., 454); Chicago, Rock Island & Pacific v. Commission (218 U. S., 88, 110); Proctor & Gamble case (225 U. S., 282, 297-298), and Louisville & Nashville case (227 U. S., 88, 91).

The salient point is that questions of the reasonableness of rates involving only facts are for the interstate commerce commission to pass upon and not for the courts to review.

The California lemon growers secured an increase in the import duty on lemons, in the Aldrich law of 1909, on the assertion that they could not otherwise continue to compete with foreign lemons. The transcontinental railways quickly raised their rates to eastern points from \$1 to \$1.15 to absorb this difference.

The commission thereupon issued an order requiring the railways to put their rates back to \$1. On appeal to the Commerce Court, that tribunal, in October, 1911, reversed the commission, holding that it was not within the province of that body to protect the lemon industry of California against foreign competition.

In December of the same year the commission reaffirmed its previous order, upset by the Commerce Court (leaving out reference to import duties) and reduced rates on California lemons to all points in the United States from \$1.15 per 100 lbs. to \$1; and ordered the carriers to make effective the lower rate on February 15, 1912. The appeal of the roads against this order is now dismissed.

## Railway Officers.

## Executive, Financial and Legal Officers.

A. M. Lee has been appointed assistant general claim agent of the Northern Pacific, with headquarters at Seattle, Wash.

Denegre, Leovy & Chaffe, of New Orleans, La., have been appointed general attorneys of Morgan's Louisiana & Texas Railroad & Steamship Company, the Louisiana Western and the Iberia & Vermilion, subsidiary lines of the Southern Pacific.

W. C. Nixon, receiver and chief executive officer of the St. Louis & San Francisco, with office at St. Louis, has been elected president. W. F. Hull has been elected assistant secretary, succeeding T. D. Heed, who resigned recently to remain with the Chicago & Eastern Illinois.

## Operating Officers.

George J. Shreeve, trainmaster of the Belt Railway of Chicago, has been appointed superintendent, with headquarters at Chicago.

Edward Bodamer has been appointed trainmaster of the Illinois Central at Fulton, Ky., in place of G. E. Gallaway, who has been granted a leave of absence.

B. A. Porter, trainmaster of the Yazoo & Mississippi Valley at Memphis, Tenn., has been appointed superintendent of the Memphis division, with headquarters at Memphis, Tenn., succeeding P. Laden, resigned.

W. G. Curran has been appointed assistant general superintendent of transportation of the Baltimore & Ohio Southwestern and the Cincinnati, Hamilton & Dayton, with headquarters at Cincinnati, Ohio.

F. D. Kelsey, division superintendent of the Great Northern at Breckenridge, Minn., has been appointed superintendent of the Butte division, with headquarters at Great Falls, Mont., succeeding P. C. Allen, resigned.

Charles E. Brooks has been appointed acting superintendent of the Montana division of the Oregon Short Line, with headquarters at Pocatello, Idaho, in place of C. F. Smith, granted leave of absence on account of ill health.

M. H. Cahill, assistant superintendent of the Cumberland division of the Baltimore & Ohio, at Keyser, W. Va., has been promoted to superintendent of the New Castle division, with headquarters at New Castle Junction, Pa., succeeding H. H. Temple, resigned.

J. D. Stack, who recently resigned as division superintendent of the Oregon-Washington Railroad & Navigation Company, has been appointed assistant superintendent of the Toledo division of the Cincinnati, Hamilton & Dayton, with headquarters at Dayton, Ohio.

I. H. Luke, superintendent of the Second division of the Denver & Rio Grande, has been transferred to Salt Lake City, Utah, as superintendent of the Salt Lake division, succeeding N. A. Williams, who has been appointed superintendent of the Green River division, with headquarters at Helper, Utah, in place of J. T. Slattery. The latter takes the place of Mr. Luke at Salida, Colo.

W. C. Nixon, receiver and chief operating officer of the St. Louis & San Francisco, announces that, effective November 15, A. S. Greig, in addition to his duties as assistant to the receivers, will be first assistant to the chief operating officer, and B. T. Wood will be second assistant. The office of assistant to chief operating officer (mechanical) will be abolished, and W. H. V. Rosing will be assigned to duty under the general superintendent of motive power. The testing department will be in charge of the latter officer also.

## Traffic Officers.

Ben R. Grove has been appointed traveling passenger agent of the Louisville & Nashville, with headquarters at Indianapolis, Ind.

W. R. Flounders, Jr., has been appointed freight solicitor of the Pennsylvania Railroad, with office at New York, succeeding E. J. Karr, promoted.

W. R. Smith, division freight agent of the Sunset-Central Lines of the Southern Pacific at Galveston, Tex., has been transferred to Austin, Tex. A. J. Morris succeeds Mr. Smith.

Henry Blakeley, general western freight agent of the Northern Pacific at Tacoma, Wash., has been appointed general freight agent, with headquarters at St. Paul, Minn., effective December 1, succeeding J. B. Baird, promoted.

Bennett Maass, commercial agent of the Macon, Dublin & Savannah, at Savannah, Ga., has been appointed contracting freight agent, with office at Macon, and his former position has been abolished. W. M. Coble, soliciting agent at Jacksonville, Fla., has been promoted to traveling freight agent, and his former position has been abolished.

**Engineering and Rolling Stock Officers.**

W. H. Rupp has been appointed chief engineer of the Sumpter Valley, with office at Baker, Oregon.

Gus Blaser has been appointed roadmaster of the Oregon Short Line at Kemmerer, Wyo., in place of J. J. Daily, resigned.

A. B. McDonald, general car foreman of the Intercolonial Railway at Moncton, N. B., has been appointed superintendent of car shops at Moncton.

J. Clifford has been appointed assistant engineer maintenance of way of the Canadian Pacific Western Lines, with headquarters at Winnipeg, Man.

S. M. Bate has been appointed division engineer of the New Orleans, Texas & Mexico and the Beaumont, Sour Lake & Western, with headquarters at De Quincy, La.

The jurisdiction of J. F. Enright, superintendent of the motive power and car department of the Denver & Rio Grande, with headquarters at Denver, Colo., has been extended over the Western Pacific.

H. B. Hayes, master mechanic of the Alabama Great Southern at Birmingham, Ala., has been appointed master mechanic of the Cincinnati, New Orleans & Texas Pacific at Somerset, Ky., succeeding Joseph Quigley, resigned.

**Purchasing Officers.**

F. C. Turner has been appointed division storekeeper of the Northern Pacific at Pasco, Wash., in place of J. C. Vollmer, resigned.

F. E. Connors, assistant general purchasing agent of the Atchison, Topeka & Santa Fe, at Chicago, has been appointed assistant to vice-president in charge of stores, with headquarters at Topeka, Kan., and E. A. Clifford has been appointed assistant general purchasing agent, with office at Chicago, succeeding Mr. Connors.

N. M. Rice, general storekeeper of the Atchison, Topeka & Santa Fe at Topeka, Kan., has been appointed chief purchasing officer of the St. Louis & San Francisco, with headquarters at St. Louis, Mo. Mr. Rice will be in charge of purchases and stores, and will have supervision and care of all material, fuel, supplies and stationery in the possession of the receivers. Effective November 15.

**OBITUARY.**

Charles H. Smith, traveling freight agent of the Chicago, Indiana & Southern, with headquarters at Minneapolis, Minn., died on November 4, aged 58 years.

Matthew J. Ramsey, chief clerk to the general manager of the Pennsylvania Railroad, died on November 9, at his home in Overbrook, Pa. He was born in Newark, Del., on April 1, 1849, and began railway work as a telegraph operator at Perkmen Junction on the Philadelphia & Reading in 1866. Five years later he entered the service of the Pennsylvania Railroad as a telegraph operator at Pier No. 2, New York City. He was transferred to Philadelphia, the following year, and in July, 1874, was appointed telegraph operator in the general manager's department. He served as a telegraph operator, and later as a clerk until February 10, 1897, and since that time had been chief clerk of the general manager's department.

**Equipment and Supplies.**

**LOCOMOTIVE BUILDING.**

THE PITTSBURGH, SHAWMUT & NORTHERN has ordered 1 mogul locomotive from the Baldwin Locomotive Works.

THE LENOX & NEW ENGLAND is said to be in the market for 5 consolidation locomotives and 3 switching locomotives. This item has not been confirmed.

**CAR BUILDING.**

THE WABASH is in the market for 500 box cars.

THE CHICAGO GREAT WESTERN is in the market for 1,500 steel underframes.

**IRON AND STEEL.**

THE BALTIMORE & OHIO has ordered 2,500 tons of structural steel from the American Bridge Company.

GENERAL CONDITIONS IN STEEL.—There is very little change in steel conditions. It is a waiting market. On the one hand, producers are not inclined to lower prices, on the ground that such a movement would induce no buying. Consumers are indifferent. They say that their own business has fallen off and they are in no hurry to buy large quantities of steel for future delivery. Independent manufacturers report that orders are not running in excess of 25 per cent. of capacity. The railroads show no disposition to buy, and no large rail orders are expected before the close of the year. Buying of railroad companies will be restricted until a decision is reached by the Interstate Commerce Commission relative to freight rates.

**SIGNALING.**

The Chicago, Burlington & Quincy has contracted with the Federal Signal Company for the installation of automatic block signals on 112 miles of road between Denver, Col., and Akron, single track. Federal style "4" top-post signals will be used.

The Alexandria & Western has given a contract to the Federal Signal Company for an interlocking plant at the crossing of the Texas & Pacific at Alexandria, La. The distant signals will be the Federal Signal Company's Type 4, power operated.

The Federal Signal Company has been awarded a contract for new interlocking at the crossing of the Burlington County Transit Railway, with the Burlington branch of the Pennsylvania, at Mount Holly, N. J. Federal style "4" top-post distant signals will be used.

The Canadian Government has given to the Union Switch & Signal Company, a contract for automatic block signals on the Intercolonial Railway, amounting to about \$85,000. The lines to be signaled are those from St. John to Hampton, 22 miles; Moncton to Painsec Junction, 7 miles, and Windsor Junction to Halifax, 14 miles.

REFRIGERATOR CARS.—According to a German paper devoted to the cold storage business there are in North America 100,000 refrigerator cars in service, besides 50,000 insulated and provided with special ventilating equipment. In the whole of Europe there are only 50,000 refrigerator cars of which 3,000 are on the Russian railways.

NEW LINE FOR INDIA.—The Southern Shan states branch line, Burma railways, is now open to Kywedatsin, 16 miles from Thazi, and trains will now run up to Yinmabin station, 7 miles further. It is intended eventually to construct the line to Yapghwe, one of the largest trading towns of the Southern Shan States, 116 miles from Thazi, and when that is completed it is considered that it will mark the beginning of a new era in the development of the Southern Shan States.

## Supply Trade News.

E. E. Hudson, sales manager of the Primary Battery department of Thomas A. Edison, Inc., Orange, N. J., has been made fourth vice-president of that company. Mr. Hudson will continue as heretofore in charge of the sales of the Primary Battery department, with headquarters at Orange, N. J. Mr. Hudson entered the signal supply business in July, 1898, with the Edison Manufacturing Company, as chief clerk in the Primary Battery department. He remained with that company until June, 1902, when he left to become treasurer of the Peerless Fashion Company. After a few months he resigned that position and went to the United States Steel Corporation as accountant in the comptroller's department. This position he retained until December, 1903, when he was made secretary and treasurer of the Battery Supplies Company, Newark, N. J. In 1905 he was made also sales manager of that company. In 1908 he returned to the Edison company upon the absorption of the Battery Supplies Company, as assistant manager of sales in the Primary Battery department. He was made manager of sales of that department in February, 1909, which position he retained until his election as fourth vice-president of the company, as mentioned above.



E. E. Hudson.

### TRADE PUBLICATIONS.

**SIDE-BLOW STEEL CONVERTER.**—The Whiting Foundry Equipment Company, Harvey, Ill., has issued catalog 106, dealing with the Whiting side-blow steel converter. This booklet contains 16 pages, is attractively gotten up and illustrated.

**AIR PUMP UNIONS.**—The National Tube Company, Pittsburgh, Pa., has recently issued a folder dealing with the Kewanee air pump union. This type of the Kewanee union is largely used on the air lines of locomotives. The subject is presented in the form of a probable conversation between a salesman and a prospective user, and offers considerable valuable information.

**ELECTRIC DRILLS.**—The Independent Pneumatic Tool Company, Chicago, has issued a circular describing two Thor electric drills which are recent additions to that line and which will be sent to any responsible person for ten days' test to ascertain their merit and adaptability. The principal feature is the fact that they are equipped with a universal motor so that the machine may be attached to the ordinary incandescent lamp socket of 110 or 220 volts, direct or alternating current, 60 cycles or less and single phase. This is claimed to be the only combination roller and ball bearing electric drill on the market. It is capable of drilling holes up to 5/16 in. diameter.

**AUTOMATIC TRAIN CONTROL.**—The Detroit automatic train control system is described and the apparatus illustrated in a 30-page booklet recently issued from Detroit. This system is an improvement upon the Prentice wireless scheme. It provides for signals both visual and audible in the engineer's cab and in the train despatcher's office, and enables the despatcher to produce a caution or danger signal at any point. The response to any danger or caution signal takes place mechanically and independently of the engineer, the high-frequency currents flowing in "wayside" circuits parallel to the track operating on two receiving circuits on the engine, and these in turn on the steam and air. The wayside circuits may be arranged to reduce the speed of the train at any point.

## Railway Construction.

**ALABAMA & MISSISSIPPI.**—An officer writes that this company, which operates a line from Vinegar Bend, Ala., southwest to Leakesville, Miss., is building a 12 mile extension in Mississippi. Contractor Houston is doing the grading work and the company is carrying out the track laying with its own forces.

**ALGOMA CENTRAL & HUDSON BAY RY.**—The Northern division has been opened for business from Franz, Ont., north to Oba, 50 miles.

**ALGOMA EASTERN.**—This road has been extended from Espanola, Ont., west to Turner (Little Current), 37 miles.

**CANADIAN ALBERTA.**—The Canadian parliament has been asked to incorporate this company to build a railway from the Canadian Pacific about a mile west of Blairmore, Alta., thence northerly and westerly through townships 8 and 9, range 4, west of the 5th meridian, to section 20 in township 9, about 14 miles. Taylor, Harvey, Grant, Stockton & Smith, Vancouver, B. C., are acting for the applicants.

**CANADIAN PACIFIC.**—On the Alberta division the Lemsford sub-division has been extended from Cabri, Sask., north to Prussia, 53.7 miles. The Coronation sub-division has been opened for business from Coronation, Alta., east to Monitor, 41.8 miles, and on the Saskatchewan division the Neptune sub-division has been opened for business from Hooper, Sask., west to Neptune, 53.8 miles.

The West Ontario Pacific has asked for an extension of time to build from a point on the main line at or near London, Ont., northerly through the counties of Middlesex or Oxford, Perth, Huron and Bruce to a point on Lake Huron in the county of Bruce.

**CENTRAL CANADA.**—The Canadian parliament has been asked to incorporate this company to build railway lines from Winnipeg, Man., in a generally northwestern direction via Yorkton, Saskatoon and Battleford, Sask., to Edmonton, Alb. Pringle & Guthrie, Ottawa, Ont., are solicitors for applicants.

**CHARLESTON NORTHERN.**—This company has applied for a charter in South Carolina, with headquarters at Darlington. The plans call for building through the counties of Georgetown, Berkeley and Charleston, from a point on the Georgetown & Western in Black River township, to Charleston, about 57 miles. D. T. McKeithan and D. Williamson, Darlington, and J. D. Evans, Florence, are interested.

**CHICAGO, MILWAUKEE & ST. PAUL.**—Work on the line from Great Falls, Mont., southeast to Lewistown 137 miles, it is understood will be finished this year. Track has been laid on 38 miles between Lewistown and Denton on the eastern end and from Great Falls east on 22 miles. Contracts were let last year to Winston Bros., Minneapolis, Minn., and to Twohy Brothers, Portland, Oregon, to build the line.

According to press reports Guthrie, McDougall & Company, Portland, Oregon, was recently given a contract for building the Puget Sound & Willapa Harbor from Maytown, Wash., to Doty, and has sub-let to Martin E. Johnson, Portland, the section from Maytown to Chehalis. Guthrie, McDougall & Company will carry out the work between Chehalis and Doty. The Keasel Construction Company is building towards Doty from Raymond. (October 10, p. 679.)

**CINCINNATI, NEW ORLEANS & TEXAS PACIFIC.**—This company has completed work on 17.5 miles of new second main track between Erlanger, Ky., and Crittenden, and it was recently put in service. The company now has a total of 106 miles of double track in operation between Cincinnati, Ohio, and Chattanooga, Tenn. Vice-president T. C. Powell announces that work is rapidly progressing on the remainder of this work on a section of about 12.5 miles, which will complete the double track to a point just below Williamstown, Ky., a distance of 38 miles from Cincinnati. (May 23, p. 1161.)

**CLEAR LAKE.**—This company has been authorized to issue \$500,000 bonds and \$261,700 stock under various conditions, in order to build a 23½ mile line from Hopland, Mendocino county, Cal., northeast to Lakeport. Work was started on the

line last year. C. M. Hammond, president, Lakeport; C. R. Rankin, chief engineer, Hopeland.

**GOLDSBORO, SEVEN SPRINGS & SWANSBORO.**—An officer of this company, which was incorporated in 1911, in North Carolina, with \$1,500,000 capital, writes that the company has not yet decided when the contract will be let to build the line. The projected route is from Goldsboro, N. C., southeast via Seven Springs, Pink Hill, Richlands and Jacksonville to Swansboro, about 70 miles. It is understood that several of the towns along the route have recently arranged to issue bonds, and the proceeds are to be used to help build the line. T. H. Pritchard, president, Swansboro.

**GRAND TRUNK.**—The Lachine, Jacques Cartier & Maisonneuve has asked for an extension of time to build lines from Lachine, Que., to a point in the Hochelaga ward, Montreal, or in Maisonneuve, passing in the rear of Mount Royal, Montreal, with extensions from the starting point to Dorval and to the northern end of Montreal Island.

**GRAND TRUNK PACIFIC.**—The Mountain division has been extended from Moricetown, B. C., west to Rose Lake, 95.7 miles.

**GULF FLORIDA & ALABAMA.**—The main line has been extended from Local, Ala., north to Broughton, 21 miles.

**LACHINE, JACQUES CARTIER & MAISONNEUVE.**—See Grand Trunk.

**MIDLAND CONTINENTAL.**—Train service is now in operation between Edgeley, N. D., and Wimbledon, 76 miles.

**MINNEAPOLIS, ST. PAUL & SAULT STE. MARIE.**—The Cuyuna line of the Duluth-Superior division has been extended from Crosby, N. D., to Riverton, 4.5 miles.

**MINNEAPOLIS UNION ELECTRIC.**—This company will ask for incorporation in South Dakota with a capital of \$2,000,000, to build from Minneapolis, Minn., northwest to St. Cloud, about 70 miles. The incorporators include A. Poulip, E. G. Garwood and P. A. Chadwick, of Minneapolis, Minn., and E. M. Lawrence, of Huron, S. D.

**NEW YORK NEW HAVEN & HARTFORD.**—The report of this company for the year ended June 30, 1913, shows that construction work on the New York Connecting Railroad has now reached a point where modification of the tracks of the Harlem River branch of the New Haven will soon be necessary, and the work will probably be carried out this year. At Westchester yard new receiving tracks have been put in. Work has been finished on the Hawleyville-Shelton double tracking, providing a double track line from Naugatuck Junction to Hopewell Junction, 68.44 miles. The Berkshire Junction-New Milford double tracking has been finished from Berkshire Junction to Brookfield Junction, the work involving the elimination of four grade crossings by building two overhead bridges, also line changes at Brookfield and at Still River. A new railroad bridge is included at Still River, also a new station at Brookfield, and the present station at Still River will be remodeled and relocated, it is expected that this work will be finished before the close of 1913. The excavation for change of alignment in connection with the proposed New Haven station has been completed, and the lowering of the tracks in the west cut to obtain sufficient overhead clearance for electrification involving the underpinning of existing walls and piers and installation of new highway bridges at Cedar, Lamberton, Dewitt streets and Howard avenue will be finished during 1913. The enlargements and extensive changes in the Cedar Hill freight yards have been completed and the total yard capacity has been increased to 1,511 cars. On the Air Line Improvement the filling of Lyman viaduct to obtain a double track roadbed has been continued during the year, and is about 60 per cent. completed, it will probably be finished before the close of 1913. The Rapallo viaduct filling will also be finished during the ensuing year. The revision and improvement of facilities at Westerly, R. I., consisting of new passenger and freight stations, revision of alignment and provision for future four-tracking, a new freight yard, additional passing sidings, passenger subway, three new bridges and the elimination of one grade crossing are about finished. The construction of double track on sections of the line between Providence, R. I., and Fall River, with line and grade revision, and elimination of grade crossings has been com-

pleted, also the double tracking East Providence to East Junction. All the work at Worcester, Mass., including the elimination of grade crossings, a new coach yard and engine facilities, connection between the Norwich & Worcester and the Providence & Worcester is finished except some minor details of signals and interlocking. The crossing at grade of the tracks of the Boston & Albany and the New Haven has been abolished, and the B. & A. tracks now pass over the New Haven tracks on a steel viaduct. The company has undertaken the elimination of five grade crossings in Pawtucket and Central Falls on a revised alignment. The plans include reconstruction of freight yards, a new passenger station over the tracks to serve both cities, eight overhead highway bridges, a foot-bridge, also third and fourth tracks. This work is expected to be finished early in 1915. Surveys for third and fourth tracks and elimination of grade crossings are about finished from East Junction to Readville, and hearings are being held on the 13 proposed crossing eliminations in the towns of Westwood, Canton, Foxboro, Sharon and Mansfield. The electrification of the Oak Point and Westchester yards has been completed. The Harlem River yard electrification is about finished, and it is expected that the Van Nest yard will be completed in a few months. The work of electrifying the main line from Stamford to New Haven is under way, and this work may be sufficiently advanced to permit electric operation between Stamford and New Haven early in 1914. The construction of the New York connecting is proceeding actively. The contracts already let cover the section from a connection with the New York, New Haven & Hartford, in the borough of the Bronx to a connection with the New York Tunnel extension of the Pennsylvania Railroad in the borough of Queens, 4.64 miles. This section includes a large bridge over the East river; the bridges across Little Hell Gate and the Bronx Kills and the viaducts across Ward's and Randall's islands. The remaining section of the road, consisting of the main line between Bowery Bay Road and Fresh Pond Junction, where connection will be made with the Long Island Railroad in the borough of Queens, 4.32 miles, will not be placed under contract until next year. This line is being built jointly by the New Haven and the Pennsylvania Railroad.

**NEW YORK SUBWAYS.**—The New York Public Service Commission, First district, has approved the form of contract for the construction of section No. 6 of routes Nos. 4 and 38, of the Seventh avenue subway, in the borough of Manhattan. This section covers that portion of the subway under Seventh avenue, between Thirtieth and Forty-second streets. This line is being built with money contributed by the Interborough Rapid Transit Company, and the form of contract was sent to that company for approval.

**ONEIDA & WESTERN.**—A contract has been given to A. M. Cook, Oneida, Tenn., it is said, to build from Oneida west about 30 miles. There will be a number of steel bridges on the line. R. J. Moncort, chief engineer, Oneida. (October 31, p. 844.)

**ONTARIO LAKE FRONT TERMINAL.**—The Canadian parliament has been asked to incorporate this company to build from a point on the Canadian Pacific between Havelock, Ont., and Central Ontario Junction, southeasterly via Campbellford, to Cobourg, and from Campbellford southerly to Brighton. C. Pringle, Ottawa, Ont., is solicitor for applicants.

**OREGON SHORT LINE.**—The Idaho Northern branch of the Idaho division has been extended from Montour, Idaho, northeast to Smith's Ferry, 42 miles.

**PACIFIC, PEACE RIVER & ATHABASCA.**—Application is being made to the Canadian parliament for incorporation to build from tide-water at the mouth of the Naas river in British Columbia east to Prince Albert, Sask., about 1,500 miles. The plans call for building along the Naas river, Courier creek, the Skeena river, and Bear river to Bear lake; thence down to Driftwood river to North Tacla lake, and via Hogam pass to the Omineca river; thence to the Findlay branch of the Peace river, and along the north side of the main Peace river to Vermillion Rapids or Chutes in Alberta, and crossing the river at the falls; thence down the right bank of the Peace river to Point Providence; thence to the Athabasca river and along that river to Fort McMurray; then following the Clearwater river and the Pembina river south to the height of land, crossing over to Buffalo river, and then

eastern and southerly to Prince Albert, Sask. Pringle, Thompson, Burgess & Co., Ottawa, Ont., are solicitors for applicants.

**PENNSYLVANIA RAILROAD.**—We are told that this company has entered into an agreement with the city officers of Philadelphia, Pa., for the removal of the tracks on Lehigh avenue in Philadelphia.

**PITTSBURGH, SHAWMUT & NORTHERN.**—The main line has been extended from Mahoning, Pa., to Kittanning, 11 miles.

**PUGET SOUND & WILLAPA HARBOR.**—See Chicago, Milwaukee & St. Paul.

**RALEIGH, CHARLOTTE & SOUTHERN.**—The main line has been extended from Mt. Gilead, N. C., south to Aquadale, 14 miles.

**SALINA CANYON.**—This company has been organized in Utah with \$1,000,000 capital to build a 35-mile line from Salina, Utah, east through Salina canyon. Right of way has been secured; the line will have a 4 per cent. grade. J. Pingree, president, Ogden; E. P. Ellison, vice-president, Layton; O. C. Beebe, treasurer, and G. S. Spencer, secretary, Salt Lake City.

**SAN ANTONIO, FREDERICKSBURG & NORTHERN.**—We are told that this company on October 31, opened the line for freight and passenger traffic from Fredericksburg Junction, Tex., where a connection is made with the San Antonio & Aransas Pass, north via Nichols, Hillington and Mt. Alamo to Fredericksburg, 23.8 miles. (September 12, p. 479.)

**WATERLOO, CEDAR FALLS & NORTHERN. (Electric).**—The Waterloo & La Porte City line has been extended from La Porte City, Iowa, to Brandon, 10 miles.

**WEST ONTARIO PACIFIC.**—See Canadian Pacific.

#### RAILWAY STRUCTURES.

**BALTIMORE, MD.**—Contracts have been given by the Baltimore & Ohio to the McLean Construction Company, Baltimore, for enlarging open Pier 5, in the Locust Point terminal, at Baltimore. The new pier will cost \$100,000, and, under the contract, will be completed in three months.

**DUNCAN, N. C.**—See Norwood.

**MAGNOLIA, W. VA.**—The Baltimore & Ohio will build two bridges on the new Magnolia cut-off. One at Magnolia, W. Va., and the other at Kessler's Curve. A contract has been given to the American Bridge Company for 2,500 tons of structural steel for the bridges.

**MARSHALL, TEX.**—The Texas & Pacific has let a contract for the construction of a 20-stall roundhouse.

**NORWOOD, N. C.**—An officer of the Norfolk Southern writes that contracts have been given to C. V. York, Raleigh, N. C., for putting up new stations at Norwood and at Duncan.

**OMAHA, NEB.**—The Chicago & North Western has announced that a new inbound freight house and office building for the general western headquarters of the company, will be erected at this point at a cost of approximately \$350,000.

**TULSA, OKLA.**—The St. Louis & San Francisco has announced plans for a new passenger station.

**VAN NEST, N. Y.**—The report of the New York, New Haven & Hartford for the year ended June 30, 1913, shows that a new repair shop, inspection shed, and blacksmith shop were completed at Van Nest, and at Oak Point a new office building, storehouse and inspection pits were also completed. At Westchester yard three 1,200-ft. freight transfer platforms and an office building have been put up, and at Pelham Bay the filling of the six-track timber trestle approach to the lift bridge is progressing. Work is nearing completion on an extension of the power plant at Cos Cob. At Ansonia, the four span reinforced concrete bridge over the Naugatuck river and the elimination of Bridge street grade crossing has been completed. Construction work is under way at Readville, Mass., on a 200-ft. extension of the locomotive shop, and at Clinton improvements are under way including the elimination of four highway and one railroad grade crossing. During the year the company replaced a number of the bridges with larger and heavier structures, and also put up a number of station buildings at various places and improved the facilities at others.

## Railway Financial News.

**FR. DODGE, DES MOINES & SOUTHERN.**—This property was purchased at foreclosure sale for \$3,900,500 at Boone, Iowa, on October 31, by Rollin B. Fisher, representing the Old Colony Trust Company, Boston, Mass., in behalf of the bondholders.

**INTERNATIONAL & GREAT NORTHERN.**—Kingdon Gould has been made a director, succeeding his father, George J. Gould, resigned.

**INTERSTATE TRANSFER RAILWAY.**—This company has filed at Madison, Wis., a notice of increase of authorized stock from \$500,000 to \$1,500,000, to provide for extensions and improvements. This road runs from a point on the St. Louis river, near New Duluth, Minn., to a connection with the Northern Pacific at Pokegama, Wis., three miles.

**NEW YORK, NEW HAVEN & HARTFORD.**—Judge Sheldon of the Massachusetts Supreme Court on November 11 refused to issue an order restraining the company from issuing the \$67,552,000 debenture bonds recently authorized by the public service commission as sought in a bill in equity filed by former Governor Morgan G. Bulkeley of Connecticut. Judge Sheldon's ruling left to the business judgment of the railroad company the question of whether it will proceed to issue the debentures. The counsel for the road said that the refusal to restrain the issue meant that no alternative arrangement would be necessary to provide for the road's \$40,000,000 notes maturing on December 1. It was announced that Judge Sheldon would sit next Monday at the hearing on the bill in equity appealing from the decision of the commission, and to consider the case on its merits. He is expected to refer the case to the full bench for a hearing. It was said that probably there would be no actual presentation of the case before the first week in December. The directors of the company had a special meeting at New York on November 11, and voted to extend the subscription date of the \$67,552,000 bond issue from November 15 to November 26, when 65 per cent. payment is to be made.

**ST. LOUIS & SAN FRANCISCO.**—On November 10 the new board of directors was chosen as follows: Thomas H. West, W. K. Bixby, Albert T. Perkins, S. W. Fordyce, W. C. Nixon, W. B. Biddle, James Campbell, Festus J. Wade and Alexander Douglas, all of St. Louis; H. H. Pierce, John T. Harris and B. F. Yoakum, all of New York; and Benjamin P. Cheney of Boston.

**NEW CENTRAL RAILWAY STATION AT WARSAW, RUSSIA.**—Since Minister Ruchlow's recent visit to Warsaw, the Russian Ministry of Communication is greatly in favor of building at Warsaw a central station which would unite those of the Warsaw-Vienna and the Kalisz railroads. The Ministry of Communications is endeavoring to have \$1,000,000 assigned for carrying out the improvement.

**NEW LINES FOR INDIA.**—The Indian Railway Board is considering a scheme for constructing some 400 miles of 2 ft. 6 in. gage feeder railways all connected together in the Montgomery, Lyallpur, Sargodha and Gujrat districts of the Punjab, to serve the canal colonies. Surveys have already been carried out in two directions from Changa Manga, between Lahore and Multan, on the North Western main line.

**STEAM AND ELECTRIC LOCOMOTIVES.**—From the information offered by many writers on the subject, one would be led to believe that a steam locomotive is a most wasteful machine and that tremendous savings would result from abandoning their use. As a matter of fact, the performance of the locomotive boiler compares favorably with the average results obtained in stationary practice, and the performance of the complete locomotive, of modern construction, is sufficiently efficient to permit of obtaining a coal rate of 2.1 lbs. per indicator horse power hour, or 2.5 lbs. of coal per horse power hour delivered at the drawbar of the tender. Surely such results do not warrant the almost general belief that the locomotive is an inefficient machine for the purpose for which it is intended.—*D. F. Crawford before the International Society for the Prevention of Smoke.*

# Railway Age Gazette

PUBLISHED EVERY FRIDAY AND DAILY EIGHT TIMES IN JUNE, BY THE  
SIMMONS-BOARDMAN PUBLISHING COMPANY,  
WOOLWORTH BUILDING, NEW YORK.

CHICAGO: Transportation Bldg. CLEVELAND: Citizens' Bldg.  
LONDON: Queen Anne's Chambers, Westminster.

E. A. SIMMONS, *President.*

L. B. SHERMAN, *Vice-President.* HENRY LEE, *Sec'y & Treas.*  
The address of the company is the address of the officers.

EDITORS.

SAMUEL O. DUNN, *Editor.*

ROY V. WRIGHT, <i>Managing Editor.</i>	H. H. SIMMONS	E. S. FAUST
W. E. HOOPER	H. F. LANE	F. W. KRAEGER
B. B. ADAMS	E. A. AVERILL	A. D. CLOUD
E. T. HOWSON	R. E. THAYER	GEORGE L. FOWLER
	A. C. LOUDON	

Subscriptions, including 52 regular weekly issues and special daily editions published from time to time in New York, or in places other than New York, payable in advance and postage free:

United States and Mexico.....	\$5.00
Canada .....	6.00
Foreign Countries (excepting daily editions).....	8.00
Single Copies .....	15 cents each

Engineering and Maintenance of Way Edition and four Maintenance of Way Convention Daily issues, North America, \$1.00; foreign, \$2.00.

Entered at the Post Office at New York, N. Y., as mail matter of the second class.

WE GUARANTEE, that of this issue 10,850 copies were printed; that of those 10,850 copies, 8,650 were mailed to regular paid subscribers and 245 were provided for counter and news companies' sales; that the total copies printed this year to date were 407,359—an average of 8,667 copies a week.

VOLUME 55. NOVEMBER 21, 1913. NUMBER 21.

## CONTENTS

<b>EDITORIAL:</b>	
Editorial Notes .....	941
The Illuminating Strike on the Sunset Lines.....	942
The Shippers and Box Car Pooling.....	944
*New York, New Haven & Hartford.....	944
New Books .....	946
<b>MISCELLANEOUS:</b>	
*Steel Passenger Train Car Situation.....	947
*William C. Brown .....	953
Has the Interstate Commerce Commission's System of Accounts Met the Needs of the Commission? by William E. Hooper.....	954
A Plan for the Joint Purchase of Freight Cars.....	957
*Comparison of Freight Train and Canal Boat Resistance; by Harold A. Houston .....	958
The Strike on the Sunset Lines.....	959
National Industrial Traffic League.....	962
National Civic Federation to Investigate Social Progress.....	964
Safety First on the Western Maryland.....	964
Train Accidents in October.....	965
*New Steel Journal Box.....	965
Talk with Passengers. Not at Them.....	965
<b>EDITORIAL: MAINTENANCE SECTION.</b>	
Editorial Notes .....	967
Bridge Inspection Methods .....	968
<b>LETTERS TO THE EDITOR:</b>	
The Technical Graduate Here and Abroad; by F. Leonard.....	968
<b>MISCELLANEOUS:</b>	
*Methods for the Inspection of Bridges.....	969
Abstract of Engineering Articles Since October 24.....	974
*The Lackawanna Frog and Switch Shops.....	975
Methods of Reducing Accidents; by R. Holland.....	978
Committees of the Roadmasters' Association.....	978
Suggested Means for Holding Laborers.....	979
Don'ts for Bridge Foremen.....	981
Raising the Relocated Panama Railroad.....	981
Repairing Wooden Tanks with Concrete.....	981
Maintenance of Way Master Painters' Association.....	982
*Scale Test Car of the United States Bureau of Standards.....	985
*An Unusual Foundation Failure.....	986
*A Scoop Car for Removing Slides.....	987
<b>GENERAL NEWS SECTION.....</b>	
	989

\*Illustrated.

THE article on the Steel Passenger Car Situation in this issue is the first of an extensive series of carefully prepared studies on timely subjects, which are in course of preparation and will be published in the *Railway Age Gazette* during the coming year. These will cover the more important problems now before the railroads in all of their departments and particularly in the operating, mechanical, and engineering branches, and in regard to the relations of the railways to the public. These studies will be prepared by experts on our staff, and no effort or expense will be spared to make them as comprehensive and thorough as the nature of the various subjects will permit. This is the most important and far-reaching program ever undertaken by a technical publication.

WHEN the radical change in design from wood to steel passenger train cars is considered, the rapidity with which steel cars have been introduced on American railways is truly remarkable. Five years ago there were only about 400 such cars in use on steam roads, and most of these were in the nature of experiments, necessitated largely by the electrification of the steam roads in and about New York City. To-day there are about 9000 such cars in use, or between one-seventh and one-sixth of the total number of passenger train cars in service. Many roads have all of their higher class passenger trains equipped with steel cars. The roads generally have stopped ordering wooden cars. Several bills have been introduced in Congress to the effect that the railways must use nothing but steel passenger train cars after certain dates, the longest period provided being too short to permit the building of a sufficient number of steel cars to replace the wooden ones now in use without very greatly adding to the present facilities for manufacturing such cars. The great cost of making the change within the limited periods proposed, instead of allowing the introduction of steel cars as the older ones require replacement, will prevent the railways from making other improvements which are of greater importance viewed from the standpoint of safe operation. In the article on the Steel Passenger Train Car Situation, which appears in another part of this issue, are discussed other reasons why Congress, if it feels that a law regulating the introduction of steel passenger train cars is necessary, should not attempt to designate the conditions under which this change should be made, but should refer the matter to the Interstate Commerce Commission or some board of experts which, after thorough investigation, will have power to deal with the matter for the best interests of all concerned.

AN interesting plan for increasing the supply of freight car equipment, and at the same time beginning an experiment on a comparatively small scale of the plan of pooling cars, which has long been under consideration by leading transportation authorities, has been suggested by Newman Erb, president of the Minneapolis & St. Louis, as outlined in a letter to this paper on another page. Mr. Erb proposes the forming of an association to which the railways of the country would subscribe a fund of \$25,000,000 in five annual payments based on their mileage or density of traffic, to be used as the basis for a credit of \$200,000,000, or enough to buy 200,000 cars. He believes that with the joint credit of the roads back of the association 20 or 30 year serial equipment bonds could be marketed readily, and that the per diem payments would more than defray the interest requirements, renewals, and insurance and gradually amortize the principal. Mr. Erb has not elaborated the details of the plan, but simply outlined it in the hope that its presentation may invite discussion. On the basis of \$20 a mile, the annual payment of a 10,000 mile railway system would be but \$200,000, and for a lesser road the original subscription on the basis of either mileage or density would be almost negligible. The stronger roads financially would, therefore, be able to continue to purchase equipment for their own needs as at present. A valuable addition would be made to the present supply of cars without affecting



the credit of individual companies in the way that equipment purchases now frequently do. The per diem charge is now supposed to represent the cost of owning a car, and the annual revenue from per diem at 45 cents per day, on 200,000 cars, assuming they were all in service at a time, would amount to \$32,850,000 in a year. The interest on \$200,000,000 at 5 per cent. would be \$10,000,000 a year, leaving nearly \$23,000,000 a year for insurance, renewals and the retirement of the equipment bonds. Repairs other than those now considered as owner's defects would naturally be paid for by the lines using the cars. Under existing conditions the freight car equipment of the country is handled not as if it were private property, but as if it were the property of a national railway system, but without the regulation that would be imposed if it were under a central control. A car pool would apply a plan of regulation to the existing methods. Mr. Erb's plan goes farther and substitutes for the varying credits of individual companies the joint credit of the railways of the United States.

IT is announced that the Pennsylvania Railroad is considering the advisability of establishing a rule that employees shall live, or take their rest, sufficiently near to their work to enable them to report for duty at any hour, day or night, with not more than one hour of necessary traveling between their home or resting place and the point where they begin work. Cases have come to the notice of the management wherein men live from 50 to 100 miles from the places where they report for duty. This subject came up in connection with the collision at North Haven, September 2, the engineman at fault in that case having spent four or five hours on the road to and from his work. He was on duty about 10 hours a day, but slept in his bed only about 5 hours. To say that the Pennsylvania is "considering" the advisability of establishing a time limit rule must be inaccurate. The officers, no doubt, are considering how soon the rule shall be put into effect, and how large a range of residence territory shall be allowed; but as to the main thing, the need of a rule, it cannot be that they will require many minutes to decide, and to decide in favor of it unanimously. And there cannot be much to be said in favor of long delay. It is a temporary hardship to have to change one's residence, but an allowance of a month is usually as good as a year. And every engineman can reflect that he himself is partly and perhaps, usually, wholly responsible for any unreasonable schedule that he has adopted or accepted. In other words, the proper adjustment of rest conditions should have been made each time he changed his regular run, settling the question of the financial burden of each change on its own merits, and not allowing burdens to accumulate. The frequent changing of men from one run to another, which has come into vogue so widely since seniority rights have been administered under the hair-splitting rules now everywhere in effect, is a distinct detriment to the service. It is the cause of much of this rest-time evil. There ought to be a radical reform. General Manager Bardo, in announcing recently the new rules which had been adopted for the enginemen of the New Haven road, assured the men that the rules were framed so that no favoritism could creep in. That is in accord with the spirit of all equitable agreements with employees, and is commendable, in principle; but this theoretical impartiality may be carried too far. Favoritism ought to be favored instead of frowned on, if that is the only means of keeping enginemen on the same runs a reasonable length of time. A company is morally bound to favor itself—favor the safety of life and limb—at least a part of the time. To perform his best service an engineman should have a regular run and should have approximately the same part of the 24 hours every day (not day and night alternately); and, having learned a run, he should not be changed to another except for good reasons connected with the good of the service. It cannot be said to be for the good of the service to promote a man very frequently (where promotion involves change of residence) just because that course is necessary to prevent some younger man from getting a slight advantage. Slight injustices, if they cannot be avoided, can be compensated in some way.

THE time to be allowed an engineman or fireman to spend going to and from his work is also a matter requiring careful attention. (Conductors and brakemen can rest, on duty, in the caboose.) Two hours (one hour each way) is a very long time to allow for this purpose. With that lee-way men will live 40 miles away from their proper and normal headquarters; they will be delayed now and then and be late in reporting for duty, and will be tempted to try to do some of their resting on the road. Many will yield to that temptation, trying to convince themselves that lying curled up on a seat in a passenger car is a proper way of resting. It is not, of course, the duty of the company to compel men to take proper rest, for it could not perform that duty if it tried; but it can refrain from encouraging the habitual practice of taking rest improperly. A rule requiring men to sleep within a certain very limited distance from the starting point of their run is entirely reasonable. A time limit allows too much uncertainty as to locality, and is justifiable, if at all, only because of the necessity of compromising with long-standing customs. One way in which men employed on trains will misuse the time allowed for rest, unless their judgments and their consciences are well educated, is set forth very suggestively in a letter recently published in *Memphis, Tenn.*, and reprinted in the *Railway Age Gazette* last week, page 927. That letter can be taken only as a suggestion, for its writer does not disclose his identity; but the suggestion is so true to life that our readers will ask for no corroboration. The need for educating the judgments and consciences of men exists everywhere. So far as concerns men on through freight runs, the habit of having no regular habit in the matter of eating, sleeping and resting is fostered by the constantly irregular hours of work, and usually is made compulsory. For this irregularity the companies are at least as much to blame as are the men; and theoretically the employer is wholly responsible, for the public—that is, the government—must hold the proprietors of a railroad responsible for its safe operation. They must take all reasonable precautions against dangers. It may be said that this irregularity of hours does not constitute a great danger. But even small dangers must be avoided, if avoidance is reasonably practicable; and who will say in this matter it is not reasonably practicable?

#### THE ILLUMINATING STRIKE ON THE SUNSET LINES.

THE strike of engineers, firemen, conductors and brakemen on the Sunset Lines of the Southern Pacific Company in Louisiana and Texas was short-lived. It began on November 13 at 7 p. m. and ended on November 17. But it was long enough strikingly to illustrate the conditions that exist on many of the railways of this country, and it will be extremely unfortunate if the illustration fails to make the impression it should on the minds of the American people. This strike was chiefly over the question of the discipline of employees. The want of proper discipline is the worst curse of railway operation in this country, and has been for years. It interferes with economy in operation and therefore makes the cost of the service to the public unnecessarily high. And it is likewise the cause of at least four-fifths of all railway fatalities and injuries other than those to trespassers. An excuse repeatedly offered by railway officials in investigations of accidents has been that they have been caused by the failure of employees to obey the orders of their superiors or the rules of the companies. This defense has not been accepted by railway commissioners or the press, who have made answer that it is the very essence of the function of railway operating officers to see that employees do understand and obey orders and rules. In his report of the investigation of the North Haven accident on the New Haven, Commissioner McChord, of the Interstate Commerce Commission, severely arraigned the former management of the New Haven because it had not maintained proper discipline.

The evidence shows that the management of the Sunset Lines has not recently been fairly subject to any such criticism. The employees have complained of the discipline administered by it.

as too severe. The management in dealing with the grievance committees of the individual brotherhoods stood firm. Finding that individually they made no headway against it the committees of the Order of Railway Conductors, the Brotherhood of Locomotive Engineers, the Brotherhood of Locomotive Engineers and Firemen and the Brotherhood of Railroad Trainmen formed a co-operative committee and demanded that the management should deal with it. The management saw that this was merely a scheme for strengthening the pressure of the brotherhoods. It, therefore, refused to meet and confer with the co-operative committee except regarding matters in which all of the employees represented by it had a common interest. The ostensible reason for the strike was this refusal of the management to meet the co-operative committee. But it is plain that this was not the real reason. The management offered to submit the controversy to the federal mediation and conciliation board. This proposition the employees refused; and all the evidence shows that their main purpose was by one means or another to force the management to relax the discipline which was the basis of a large part of the grievances assigned as the grounds for the strike.

Since the strike plainly was in the main an attack on the discipline administered by the management, it is desirable to know the causes and nature of this discipline. The employees have made public a list of 67 alleged grievances. The management in reply has made public detailed statements of all these 67 cases. Space will not permit us to publish analyses of all these cases, but we give below brief analyses of 30 of them. It is to be wished that every citizen of the United States might read these analyses, for they throw more light on the conditions affecting discipline on American railways, and the attitude of the railway brotherhoods toward it, than any other information which we have ever known to be put in print:

No. 1 is a demand for reinstatement of an engineer and a conductor with pay from date they were relieved from the service until date of their reinstatement. These men were discharged for operating a train over a bridge in course of repair, over which speed was limited by special instructions to four miles per hour, at a much higher rate, resulting in derailment and consequent heavy loss.

No. 2 is a demand for the reinstatement of an engineer and a conductor who were discharged because of violation of the rules of the company. The superintendent found these men on the main line with a light engine on the time of a passenger train without protection. They thereby created a condition which greatly endangered many innocent persons.

No. 3 is the protest of an engineer and a conductor against the assessment of demerits against their records for responsibility for a serious accident due to their having exceeded speed prescribed by special time table instructions; also a protest against another assessment of demerits against the same conductor on account of improper handling of live stock and a request for the reinstatement of this conductor, he having been relieved from the service on account of an accumulation of demerits.

No. 4 is a demand for reinstatement of an engineer discharged on account of responsibility for a rear end collision. A plea for leniency was originally presented, the responsibility of the engineer being admitted. On account of gross carelessness displayed by him the plea was denied.

No. 5 is a demand for reinstatement of an engineer discharged on account of having given up an engine on the road and reported it was not safe to move, when, in fact, the engine was put in shape to move a full train in a very short time.

No. 6 is a demand for the reinstatement of an engineer discharged for allowing his engine to run out of water, when all that it would have been necessary for him to do would have been for him to have fired up the pump boiler and pumped enough water to supply the engine. Investigation developed that the engineer had been drinking on the trip.

No. 7 is a demand for the reinstatement of an engineer discharged for violating the company's rules by exceeding speed restrictions over a certain portion of the line, thereby creating danger of accident.

No. 11 is a complaint of engineers against being required to make entries on a printed form after completing a trip or a day's work showing their hours of service and hours of rest, which report is necessary in order to prevent violations of the federal hours of service law. The case was handled by the joint working board, and as the reports were absolutely necessary, a demand for discontinuance of the practice was denied.

No. 14 is a complaint against engineers being required to make reports of fuel used on trips. These reports are necessary in order to keep a check on fuel, a very heavy item of expense, and to prevent waste. The practice is of long standing.

No. 26 is a demand for reinstatement of a conductor with full pay, who had been discharged for failing to comply with rules, thereby causing a serious rear-end collision.

No. 27 is a demand for reinstatement of seven passenger conductors who were dismissed because their services were no longer desired. The grievances of these men have never been discussed by the general committee of the conductors' organization with the general officers of the company, as required by practice of years' standing, and are not properly in the hands of the grand officers of the organization.

No. 28 is the protest of a conductor against assessment of demerits for violation of rules covering handling of train orders. The case has never been discussed with general officers of the company by the general committee of the conductors, and is not properly before the grand officers.

No. 29 is a demand for reinstatement of a conductor with full pay. The conductor was discharged for violating the rules by failing properly to protect his train, thereby inviting an accident. The case has never been discussed with the general officers of the company by the general committee and is not properly before the grand officers.

No. 30 is a demand for reinstatement of a switchman with pay. He was discharged for failure to report for duty at the time and place designated by the yardmaster as provided in the yardmen's agreement.

No. 31 is a demand for reinstatement of a brakeman with pay. He was discharged for refusing to pilot the engine of the train upon which he was working from a yard track to the roundhouse in the absence of the yard men.

No. 32 is a demand for reinstatement of a brakeman with pay. This man was relieved from train service because of his inability to read and write, making it impossible for him to pass written examination on train rules. He was offered employment in another capacity where his educational disabilities did not disqualify him.

No. 38 is a demand for reinstatement of three switchmen with pay. They were discharged for refusing, in succession, in an emergency, to act as foreman on a yard engine when directed to do so by the yardmaster. Insubordination meets with summary action on all railroads, and, in the interest of discipline, cannot be tolerated.

No. 39 is a demand for reinstatement of a switchman with pay. He was discharged for refusing, in an emergency, to act as foreman of a yard engine when directed to do so by his yardmaster.

No. 40 is a demand for reinstatement of a switchman with pay. This switchman was laying off and refused to return to work in an emergency, and when directed to do so by his yardmaster. Another case of insubordination.

No. 43 is the protest of a conductor against demerits for violation of rules governing handling of train orders.

No. 44 is a demand for reinstatement of an engine foreman with pay. He was discharged for failure to comply with the company's rules governing protection of his engine and cars against second class trains in yard limits, resulting in a collision.

No. 49 is a demand for reinstatement of a switchman dismissed for engaging in a fight with a night yardmaster. The case has never been discussed by any committee with the general officers, and they are not familiar with the facts in the case.

No. 54 is the protest of an engineer against assessment of demerits for interfering with a division officer who was engaged in making an efficiency test.

No. 55 is the protest of an engineer against assessment of demerits for failure to make time with a stock train. Investigation developed that the engineer did not perform his whole duty, or use his best efforts to get over the road.

No. 56 is a protest against the re-examination of engineers on train rules and mechanical re-examination of engineers. These re-examinations have been required from time to time for many years and are necessary in order to maintain the proper standard of efficiency.

No. 58 is the protest of an engineer against assessment of demerits for allowing an engine in his charge to fail on the road, when, by proper efforts, the failure could have been avoided.

No. 60 is a request for reinstatement of a conductor with pay. He was dismissed for violating positive instructions with respect to the sixteen-hour law.

No. 65 is a request that instructions issued September 11, 1912, by the Southern Pacific Company (Pacific System) relative to employees who took the places of striking shopmen be issued and made effective on the Sunset lines. This case has never been discussed with any committee and the officers do not know what instructions are referred to.

No. 66 is a complaint against alleged misapplication of the Brown system of discipline. This case has never been discussed with any committee and the company's officers do not know what the complaint consists of.

No. 67 is a request that in making surprise or efficiency tests, the officials making such tests will change indicators, uncover headlights, turn markers, etc., themselves, instead of requiring employees in train and engine service to do so.

When in the past it has been charged that the labor brotherhoods positively, deliberately and persistently interfered with discipline in such a way as to hinder railway officers in their efforts to increase the economy and safety of transportation the charge has been denied by the spokesmen and defenders of the brotherhoods. They have said that while the brotherhoods may never have done anything positive to promote safety, they never have done anything that positively interfered with it. Who

will ever again, after this astounding strike on the Sunset lines, have the bald effrontery to offer any such defense of the brotherhoods? This strike indicates, as has no other event in the history of the railways of this country, a peril with which the managements of the railways and the public are confronted. It shows not only that the brotherhoods do deliberately, persistently and in the most unreasonable way interfere with discipline, but that they have so little respect for the rights and interests of the public that they will unhesitatingly tie up whole railroad systems, regardless of the losses inflicted on innocent persons, if they conceive that they may thereby make their interference with discipline more effective. Never before was there so strikingly demonstrated the need for legislation prohibiting strikes on railroads before arbitration, and turning over to some permanent board the arbitration on their merits of all controversies arising between railways and their employees.

#### THE SHIPPERS AND BOX CAR POOLING.

IT is not only in periods of car shortage that the public is interested in the freight car question and the rules which the railways have in effect for the interchange of freight cars. These rules are formed largely on the theory that foreign cars will be returned to their owners, and it is only too frequently that this theory runs against the immediate interests of the public. Indeed, it is maintained by some that the home-route theory is generally against the real interests of the public.

Whenever freight is offered for shipment in one direction and the only available cars route home in another direction, there is a chance for friction with the shipper. Either the shipment is delayed until other cars are secured, or the cars on hand are loaded away from home.

Further, in cases where consignees desire to load out foreign cars received under load, there is continual trouble, and sometimes delay, when the route their freight should travel does not fit the home routing of the cars. In large works where the shippers do their own shifting there is often a very considerable expense involved in shifting out empties which are not available for outbound loading, and shifting in the proper empties. This is especially the case in large competitive points where the solicitation of traffic is brisk.

Railway men are apt not to do the shippers justice for the work they do in this direction. They so often hear complaints from car owners in cases where shippers insist on the "diversion" of foreign cars that they perhaps do not fully appreciate the cases where shippers are trying to help them to return cars to their owners.

Under the circumstances, it is not surprising to find that shippers generally are in favor of the pooling of freight cars by railways.

This is evidenced by the recent action of the National Industrial Traffic League in approving the report of its Committee on Transportation Instrumentalities, which is published in another column. The report recognizes the great difficulties inherent in the question, but gives as the view of the League that "a pool of common box cars seems to afford the necessary relief."

The League understands that the American Railway Association is now soliciting mail advices from its members on the question of a standard box car 40 feet long. This would seem to be in line with the recommendation recently made by President Ripley, of the Santa Fe. The League also quotes, with approval, from the report of the Commission on Car Service to the American Railway Association made some months ago.

It is pointed out that the chief defect in the present rules for the interchange of cars lies in the fact that every car is subject to the same rule. Now, there are a great many different kinds of cars. It may well be that all box cars should be handled under exactly the same rules, or that all flat cars should be handled under the same rules, but it seems a question whether cars built for special purposes should be handled under exactly the same rules as cars which can normally be used by any railroad

and at any time. The League recognizes that there are certain special types of equipment which should be returned promptly to the owner even if this invariably entails empty return mileage. Such cars can be very properly handled under the present rules of the American Railway Association.

On the other hand, there are general service cars, of which the common box car is a chief type, which can be used advantageously everywhere. The League believes that a rule should be so devised that these cars can be used so as to carry as much freight as possible, and make as little empty mileage as possible, and with the elimination of all unnecessary switching.

There is no doubt that the present car service rules of the American Railway Association, if pushed to their logical conclusion, result at times, and with certain kinds of cars, in unnecessary mileage to the railways, and a corresponding car shortage to the shippers. Even in times of car surplus, they result in expense and delay, both to the railways and shippers, which it would be well to avoid.

It is to be hoped that the American Railway Association will take some forward step with respect to this situation.

#### NEW YORK, NEW HAVEN & HARTFORD.

NOTWITHSTANDING the part that has been played by the New Haven subsidiaries in recent discussions of this company's affairs these subsidiaries are of minor importance, not only to the public served, but also to the New Haven security holders, compared to the economical operation of the great railroad property itself. In proof of this it is only necessary to point out that whereas in 1913 the deficit, after paying  $7\frac{1}{2}$  per cent. dividends, was \$4,564,000, if the railroad had had transportation expenses (excluding, of course, maintenance charges) as low per train mile as the New York Central & Hudson River, and revenue, maintenance, taxes and fixed charges and other income had all been the same, the New Haven income account would have shown a surplus of more than \$1,000,000. Transportation expenses per total revenue train mile on the New Haven in the fiscal year 1912-1913 were \$1.07; on the New York Central in the calendar year 1912 these expenses were 84 cents. Now the interesting point about this lies in a study of why transportation expenses per train mile are so much higher on the New Haven than on a road like the New York Central. If, of course, the entire difference or the greater part of the difference was within the power of the management to remedy, the prospects of the New Haven would be good indeed.

Comparing the transportation expenses in detail, there are certain discrepancies which must be eliminated at once. The New Haven has a debit of \$1,046,000 for operating joint yards and terminals, with an offsetting credit of but \$89,000, while the New York Central has a debit of \$381,000, with a credit of \$953,000. This is a total difference of \$1,529,000. The New Haven charges \$686,000 for operating floating equipment, for which there is no corresponding charge in the New York Central's transportation expenses.\*

It should also be remembered that nearly two-thirds of the total train mileage on the New Haven is made by passenger trains, while only slightly more than half of the New York Central's train mileage is made by passenger trains. The most noticeably higher costs per train mile on the New Haven as compared with the New York Central are shown in the following table:

	New Haven.	New York Central.
Station employees and station supplies expenses	20.6	14.1
Road trainmen .....	12.2	10.4
Fuel .....	19.1	15.1

This table could be carried considerably further, and on the other hand there are items under transportation expenses which are lower per train mile on the New Haven than on the New York

\*The New York Central includes in its auxiliary operations harbor terminal transfer both revenues and expenses.

Central; but the three items which are shown are typical. Station employees and expenses are high on the New Haven because there is a very large number of stations per train mile. It may be possible to effect some slight economies; but here is a good instance in which at first glance one might say that the economy of the road was poor, where as a matter of fact the service which the New Haven renders precludes the possibilities of any great economy along these lines.

As to the difference in cost per train mile of road trainmen, the east end of the New Haven is one big classification yard and calls for a large number of short runs, so that the company does not get its full quota of mileage per crew. The average haul on the New York Central for freight was 199 miles in 1912, and on the New Haven, 95 miles. It is safe to say that every ton of freight on the New Haven was handled through a terminal twice to one handling on the New York Central.

The fact that of the total tonnage carried by the New York Central 45.73 per cent. was products of mines and 30.24 per cent. merchandise and miscellaneous, while on the New Haven 31.70

may show a savings in transportation expenses, at least per train mile.

The freight train load on the New Haven is low, 291 tons in 1913, or slightly less than in 1912. The New York Central's train load in 1913 of revenue freight was 465 tons. If we could, therefore, compare transportation expenses per ton per mile on the New Haven and on the New York Central, the New Haven showing would be still worse. New Haven's small average train load, however, is due in some part to conditions which the New York Central does not have to meet. The New Haven's passenger density on its main lines is so great that freight trains have necessarily to be run on a very fast schedule to keep out of the way of passenger trains, and this is prohibitive of heavy loading. On the other hand, on its branch lines—and from the map it is apparent what a mass of these branch lines there are—freight trains have to be run on a schedule to meet the requirements of shippers; in other words, trains have to be run whether or not there is lading for them, and while both of these conditions apply to some extent on the New York Central—and

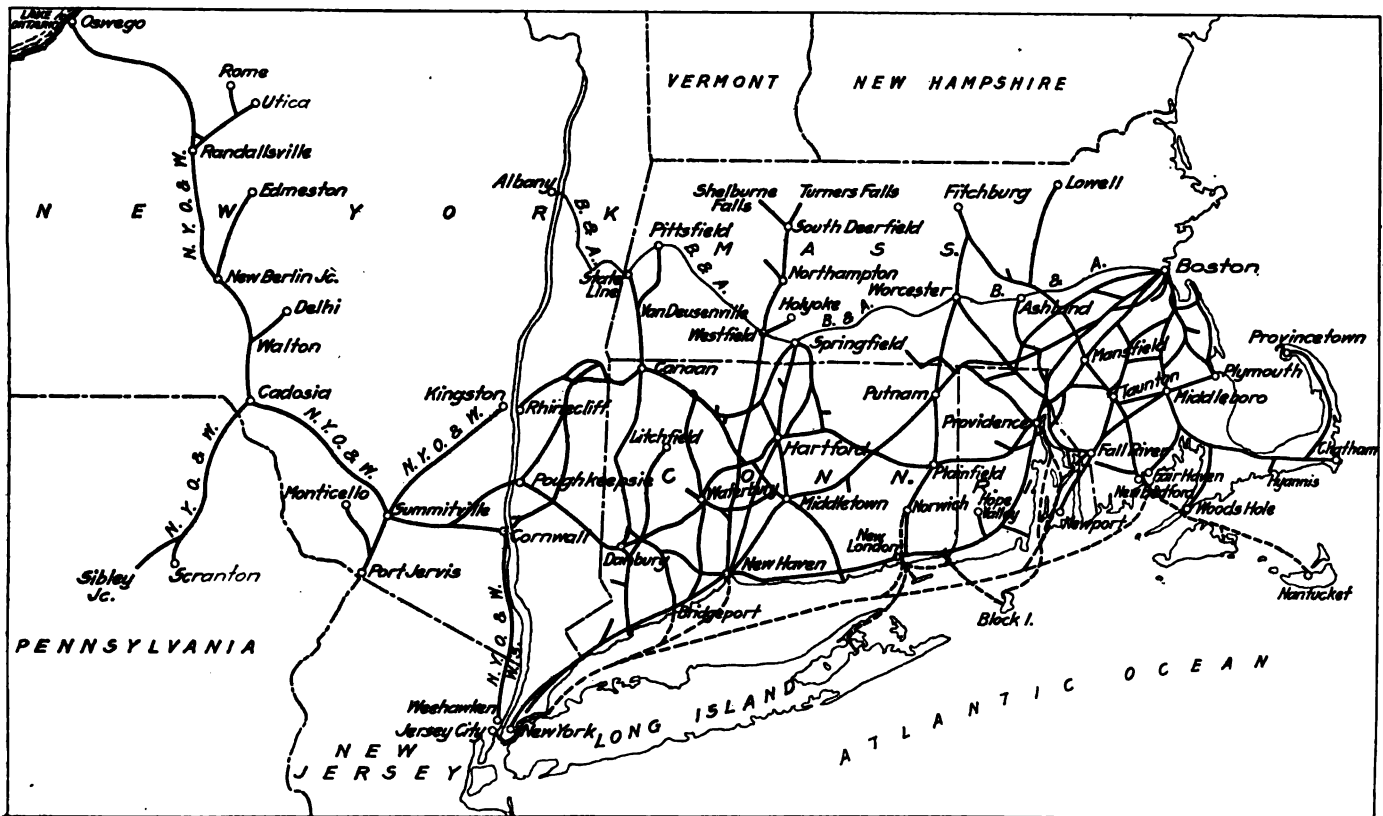

The New York, New Haven & Hartford System.

per cent. was products of mines and 52.24 per cent. merchandise and miscellaneous, is also instructive.

The difference in cost of fuel on the New Haven and the New York Central accounts for almost all, if not quite all, of the difference in fuel costs per train mile. Coal costs in the neighborhood of \$1.75 to \$2 on the New York Central and \$2.50 on the New Haven.

When we analyze each of the various classes of transportation expenses and study conditions under which these expenses are incurred, it is easy to find an explanation of nearly all of the differences that exist between New Haven and New York Central train mile cost. It is not, however, so easy to suggest what line of attack the management will take in attempting to hold down or reduce expenses. For instance, it is true that the New Haven has a great number of short runs which are expensive both in fuel and in wages of trainmen; but if Mr. Hustis' work on the Boston & Albany can be taken as an indication of what may be expected on the New Haven, it is fair to believe that a few years

this is the reason why the N. Y. C. is used for comparison—they do not apply by any means to as great an extent as on the New Haven.

Here is a tremendously complicated situation that needs study and supervision by those having full authority. If we may judge by some of the testimony before the Interstate Commerce Commission in its recent investigation of New Haven affairs, high authority and personal supervision did not go hand in hand. The result of this, together with the bitter criticisms that have been made against the New Haven management, have tended naturally to weaken discipline and to demoralize the organization and the authority of officers over employees. To overcome this will take patience and courage, but, above all, backbone bred of a knowledge that the policy pursued is one founded on principle, and not expediency, and fair dealing. Luckily for the New Haven, this latter quality has been peculiarly characteristic of Mr. Hustis in his work on the Boston & Albany.

The New Haven property as a railroad property has tre-

measured possibilities. The total road operated in 1913 was 2,114 miles, with 901 miles of second track and about 130 miles each of third and fourth track with nearly 1,500 miles of sidings. The main four-track line from Woodlawn Junction, just outside of New York City, to Stamford, Conn., 21.67 miles, has been operated by electricity since and the greater part of electrifying the line as far as New Haven has been completed, and it is expected that electrical operation will begin during the present fiscal year. In 1913 the New Haven carried 26,300,000 tons, the average haul being 96 miles; and 86,800,000 passengers, the average passenger journey being 19 miles. The New Haven, being very largely an originating road, gets a generally fair division of rates, and the average ton mile rate for freight is higher than almost any other road in the East. In 1913 the average ton mile rate was 1.345 cents, which was slightly less than in 1912. The average receipts per passenger mile are, as would be expected with its large suburban and commuters' business, low, being 1.737 cents.

The New Haven is and has been a well maintained property. The expenditure per track mile (two miles of sidings being taken as equal to one mile of track in main line or branches) in 1913 was \$2,002. The repairs, exclusive of renewals and depreciation, per locomotive in 1913 was \$2,303; per passenger train car, \$565; per freight train car, \$61.

The New Haven has no very heavy power, of course, because with the fast schedules for freight, heavy power would be a hindrance rather than a help, and a comparatively light passenger locomotive can pull 10 or 11 cars between New York and Boston. On the main line out of New York 100-lb. rail, screw spikes and treated ties are standard, and in 1913, 13,241 tons of 100-lb. rail were laid.

The immediate financial standing of the New Haven is, of course, complicated by the problem of subsidiary companies. The principal of these companies are the Boston Railroad Holding Company, through which the New Haven owns a majority of the stock of the Boston & Maine, the Holding company's stock being carried on the New Haven's books at \$27,600,000; the New England Navigation, Company, which company owns or leases the sound and coastwise water lines, and whose stock is carried on the New Haven books at \$56,900,000; the New York, Ontario & Western, the majority stock of which is owned by the New Haven, which stock is carried on the New Haven's books at \$13,100,000; the New York, Westchester & Boston, the stock of which is carried on the New Haven's books at \$6,240,000 and its bonds at \$2,000,000, but for which the New Haven has also guaranteed interest on \$19,200,000 bonds and to which the New Haven has made advances; the Rock Island Company, a trolley holding company, the stock of which is carried on the New Haven's books at \$24,350,000. This gives some idea of how involved is the question of disposing of these assets and the consequent reconstruction of the New Haven's balance sheet. The balance sheet of the railroad company at the end of 1913 showed \$12,280,000 cash on hand, with \$42,600,000 loans and bills payable. The Massachusetts railroad commission has just approved of an issue of \$67,500,000 6 per cent. convertible debentures, and these debentures are being offered to stockholders at par. New Haven stock until a very few years ago was considered as essentially an investment stock and sold at prices, when paying 8 per cent. dividends, to yield the investor 2, 4 and 5 per cent. In the latter part of the present year the directors reduced the annual rate from 8 per cent. to 6 per cent., and Mr. Elliott's frank statement to the stockholders at the annual meeting a few days ago apparently foreshadows a further reduction to 4 per cent. Even with 4 per cent. dividends at the present market price of the stock it would yield about 5 per cent.

Involved as has been the financing of the New Haven in regard to the purchase of subsidiaries, etc., the parent company's issues of securities, exclusive of its guarantees, has been on a sound basis. At the end of 1913 there was about \$180,000,000 outstanding stock and \$203,000,000 outstanding debt. Of this debt \$143,070,000 are simply debentures, without mortgage lien,

upon specific property, and \$48,790,000 of these debentures are convertible into stock.

The following table shows the principal results of operation of the railroad company for the fiscal year ended June 30, 1913, as compared with 1912:

	1913.	1912.
Mileage operated.....	2,114	2,114
Freight revenue .....	\$34,071,975	\$31,654,186
Passenger revenue .....	27,896,300	26,816,435
Total operating revenues.....	68,613,503	64,456,358
Maint. of way and structures....	7,893,090	6,745,883
Maint. of equipment.....	9,660,669	7,983,858
Traffic expenses .....	582,310	412,880
Transportation expenses .....	27,203,271	24,833,726
General expenses .....	1,947,999	1,650,965
Total operating expenses.....	47,227,339	41,627,312
Taxes .....	3,714,756	3,719,548
Operating income .....	18,316,855	20,497,654
Gross income .....	28,380,640	30,800,762
Net income .....	8,922,238	13,385,551
Dividends .....	13,486,563	14,315,540
Deficit .....	4,564,325	929,989

### NEW BOOKS.

*Commission Regulation of Public Utilities.* Compiled and published by the National Civic Federation Department on Regulation of Interstate and Municipal Utilities. Distributed by the Traffic Service Bureau, Chicago. 1,284 pages; 6 in. x 9 in.; cloth. Price \$8.50.

This is a compilation and analysis of the laws of 43 states and of the federal government for the regulation by central commissions of railways and other public utilities, prepared as a part of an investigation of public utility regulation begun in February, 1912, under the direction of the executive council of the department on regulation of interstate and municipalities of the National Civic Federation, of which Emerson McMillin is chairman. Commission regulation being the object of the investigation the field was limited to commission jurisdictions, the laws of states that have no commission being omitted from the analysis. However, while the special purpose for which it was prepared has tended throughout to narrow the scope of the compilation, the ultimate value of the work for general use has prompted liberal treatment of most topics, and within its scope the analysis of laws is practically complete. Analogous material from each of the different jurisdictions relating to some 300 different topics has been brought together and edited on a uniform basis, with elaborate indexes and cross-references, and liberal use has been made of the large mass of statutory provisions for the proper enforcement of which authority is conferred upon commissions without having been made integral parts of the commission laws. The compilation is grouped under chapters as follows: Organization of Commissions, General Powers of Commissions, Basis of Rate Making, Establishment and Change of Rates, Publicity of Rates, Discrimination in Rates, and Service, Safety of Operation, Accounts, Reports, Franchises, Stock and Bond Issues, Intercorporate Relations, Commission Procedure and Practice, and Enforcement, and the material under topics and sub-topics in each chapter is displayed by jurisdictions in alphabetical order. The work appears to have been most carefully done, and the result should be of value to lawyers, students of regulation, and to all who are interested in the work of the various regulating commissions.

*Railway Track Handbook.* Bound in leather, 124 pages, 4 in. x 6½ in., illustrated. Edited by Bruce V. Crandall. Published by the Spencer, Otis Company, Chicago, New York and St. Louis.

This book contains a large amount of data regarding the amount of rail splices, bolts and other material required for a given length of track with costs. The current prices of track and much other material required in maintenance work are given in detail with the amounts required for given units of work. The book is prepared in an attractive manner and should be of value for reference in estimating the cost of work.

# STEEL PASSENGER TRAIN CAR SITUATION.

Frank Discussion of Various Features Which May Affect the Extent and Rate at Which Such Cars Will Be Introduced.

Several bills looking toward the compulsory introduction of steel passenger train cars within limited periods, have been introduced in the Sixty-third Congress. Representative Raymond B. Stevens of New Hampshire, chairman of a sub-committee of the House Committee on Interstate and Foreign Commerce appointed to deal with railway regulation, was reported recently to have said that the steel car problem "should be solved by a small body of experts who are making a life study of it, rather than by 435 members of Congress who know nothing about the subject technically. The way to deal with the problem is to turn the whole question over to the Commission, with power to act when occasion demands."

## WHAT ACTION SHOULD CONGRESS TAKE?

The main purpose of this article is to set forth reasons why governmental action in this matter, if any is to be taken, should be delegated, as urged by Representative Stevens, to the Interstate Commerce Commission and not dealt with in detail by statute. In support of this view four principal reasons may be given:

(1) The railroads already have practically ceased ordering wooden cars. The percentage of new wooden passenger train cars placed in service has dropped from 51.4 during 1909 to 3.3 during that part of 1913 thus far reported. During the first six months of 1913 no wooden cars were ordered. No drastic mandatory statute is called for when those affected are already doing voluntarily what is sought.

(2) It is out of the question to draw a bill fixing a time within which the change to steel cars must be completed, because nobody knows what the car building capacity of the country is going to be. Existing plants would require at least ten years to supply steel cars to replace the wooden ones, and experience alone can tell to what extent private capital will invest in new shops and shop extensions.

(3) Only 3.1 per cent. of those killed and 21.2 per cent. of those injured in accidents on American railways in 1910 were passengers. Safety measures other than steel cars are evidently needed. A mandatory statute compelling the expenditure necessary for specific provision of steel cars of a stated type within a definite period in all passenger trains might absorb so much money for that purpose as to force neglect of other improvements, more important in the interest of safety than steel cars.

(4) Nobody can draw a bill specifying the type of car which will best insure safety, because expert opinion still differs as to the respective merits of all-steel, steel frame and steel underframe construction, and other important details involving both safety and cost.

## RAILROADS HAVE ALREADY ADOPTED STEEL CARS.

On January 1, 1913, according to Bulletin 53 of the Special Committee on Relations of Railway Operation to Legislation, there were on 247 railroads in the United States, owning 57,493 passenger train cars and operating 227,754 miles, a total of 7,271 all-steel cars, 3,296 steel underframe cars and 46,926 wooden cars. The rapid rate at which all-steel cars have been

placed in service during the past few years is shown by the following table, which is taken from that bulletin:

	Total Number.	Percentages.		
		Steel.	Steel Underframe.	Wood.
1909 .....	1,880	26.0	22.6	51.4
1910 .....	3,638	55.4	14.8	29.8
1911 .....	3,756	59.0	20.3	20.7
1912 .....	2,660	68.7	20.9	10.4
January, 1913 (under construction) ..	1,649	85.2	11.5	3.3

For the first six months of 1913 orders were placed by the roads included in the above report for 1,140 passenger train cars, of which 1,064, or 93.3 per cent., were of all-steel construction, and 76, or 6.7 per cent., had steel underframes. No wooden cars were ordered.

## WHY THEY WERE INTRODUCED.

While the extensive use of metal for passenger car construction was considered as early as 1854, it was not until about 40 years later it began to receive serious consideration. According to a committee on Steel Passenger Cars, which reported at the 1908 meeting of the Master Car Builders' Association, the most important reasons which brought the desirability of introducing steel passenger cars prominently before the railroads were:

(1) The burning of wooden cars in wrecks, and the frequent destruction of human life by fire.

(2) The splintering of the large wooden sills, etc., when the cars were wrecked, causing injury and death.

(3) The scarcity of lumber suitable for sills, stringers, etc., and the threatened exhaustion of such material.

(4) In collision with steel freight cars, which were being introduced in great numbers, the passenger equipment was more liable to destruction than was the case with the wooden freight cars.

(5) Increased speeds, greater train lengths, and larger capacity cars.

Then too, the rapidly increasing use of electric motor cars in subway and elevated service, where the passengers cannot easily leave the cars in case of accident, and the danger from fire where electric power is used, suggested the use of non-inflammable materials in the construction of these cars. This was undoubtedly largely responsible for the development of the all-steel passenger train car, as indicated in the brief sketch of the early stages of the introduction in another section of this article.

The movement received its great impetus in the East because of the electrification of the steam roads entering New York City and the possible dangers if wooden equipment were to be used in connection with the use of electric power in the long tunnels. In the West, on the Harriman Lines, steel cars were introduced because of the belief that they would prove safer and more economical to maintain than wooden equipment.

The publicity departments of the roads which first started to introduce the steel equipment were not slow to realize the advertising value of having all-steel cars on their limited trains, and this undoubtedly had some considerable influence in in-

## Synopsis.

*What Action Should Congress Take?*  
*Railroads Have Already Adopted Steel Cars.*  
*Why They Were Introduced.*  
*Rapid Development of Steel Cars.*  
*How Fast Can Steel Cars Be Built?*  
*What Will It Cost?*  
*Steel Frame vs. All-Steel Cars.*  
*Are Steel Cars Needed?*  
*Behavior of Steel Cars in Wrecks.*  
*Views of the Interstate Commerce Commission.*  
*Conclusions.*

ducing the other roads, particularly those in competitive territory, to adopt such equipment for their better class trains.

**RAPID DEVELOPMENT OF STEEL CARS.**

The first steps in the progress of the introduction of steel passenger train cars were outlined in an editorial on the "Rapid Increase of Steel Passenger Equipment" in the *Railway Age Gazette* of August 15, 1913, page 257. The steel frame, side door suburban cars used by the Illinois Central to handle the World's Fair traffic in 1893 are generally regarded as the forerunners of the all-steel passenger car in this country. In the same year the Pressed Steel Car Company built 35 steel underframe cars for the Northwestern Elevated of Chicago. Then followed a steel frame car for the Interborough Rapid Transit Company of New York, a steel car on the Second Avenue Elevated Line in 1904, and the building of 300 all-steel cars for the New York subway in the same year. A steel baggage car was put in service on the Erie in 1904. In the winter of 1904-5 the Long Island introduced 134 steel suburban cars in its electric service, and the Erie added a steel postal car and a steel express car to its equipment. In 1906 the New York Central put in service 125 steel motor cars (these were the first cars built of steel along the lines of a modern steel coach), the New Haven two steel postal cars, the Long Island an all-steel passenger coach, while both the Pennsylvania and the Southern Pacific built experimental all-steel passenger coaches for through traffic. The Pennsylvania also introduced a steel baggage car late in the year.

The year 1907 marked the introduction of a steel postal car on the Southern Pacific, the building of a steel Pullman car, 40 steel passenger cars for the Hudson & Manhattan, a steel postal car and a passenger coach on the Union Pacific, five steel postal cars and a steel passenger car on the Pennsylvania, and 50 more all-steel cars for the Interborough.

The M. C. B. report at the 1908 convention showed that there were about 380 all-steel cars in service or under construction for steam roads at that time, and commented on the fact that the greatest development was shown in the East because of the desirability of having fireproof cars for use on the electrified portions of the roads entering New York City, with their long tunnels. By January 1, 1909, there were 629 all-steel and 673 steel underframe cars in service in this country.

**HOW FAST CAN STEEL CARS BE BUILT?**

Records in the annual statistical numbers of the *Railway Age Gazette* show that for the past five calendar years a little more than 16,000 passenger train cars—wood, steel underframe and all-steel—were built for use in the United States. This is at the rate of about 3,200 a year. There is some little difference of opinion as to just how many all-steel passenger cars it would be possible to build per year. Two of the large builders estimate that with present facilities 3,500 such cars could be built each year; a canvass made by the Committee on Relations of Railway Operation to Legislation indicates that the maximum number of all-steel cars which can be built at the present time is about 4,630 per year. One builder is authority for the statement that about 5,000 can be built if some of the steel freight car shops can be fitted with equipment for handling steel passenger cars. This might be all right when orders for freight equipment are scarce, as at present, but this business is bound to pick up and require all the building facilities which are available.

In the investigation by the Interstate Commerce Commission of the North Haven wreck, General Manager Dean, of the Pullman Company, furnished the following information as to the annual maximum capacity of the various car building plants in the country, based upon being able to secure an adequate supply of the necessary material and labor:

American Car & Foundry Company:	
Jeffersonville, Ind. ....	300
St. Charles, Mo. ....	480
Berwick, Pa. ....	600
Wilmington, Del. ....	300
	<hr/> 1,680

Standard Steel Car Company, Pittsburgh, Pa.; plants at Butler, Pa., New Castle, Pa., and Hammond, Ind. ....	420
Pressed Steel Car Company, McKees Rocks and Pittsburgh, Pa. ....	360
Barney & Smith Car Company, Dayton, Ohio. ....	420
Harlan & Hollingsworth Corporation, Wilmington, Del. ....	250
Wason Car Company, Springfield, Mass. ....	180
Laconia Car Company, Laconia, N. H. ....	120
The Pullman Company, Pullman, Ill.:	
Passenger equipment .....	1,200
Pullman cars .....	600
	<hr/> 1,800
Total .....	5,230

It will be necessary to provide about 47,000 cars, if all the wooden and composite cars are to be replaced. Making no allowance for additional equipment required for increased traffic and new lines, at least ten years would be required for building this equipment, assuming that the project could be financed, that the builders would increase their facilities to take care of the business, and that labor conditions would allow them to secure a maximum output. On the basis of the past year's output this latter assumption is rather wide of the mark.

**WHAT WILL IT COST?**

Various estimates have been made as to the probable cost of replacing the passenger cars with those of all-steel construction. Probably the most accurate of these is that made by the Special Committee on Relations of Railway Operation to Legislation in its Bulletin 53. It is estimated that \$614,619,100 will be required for replacing 46,926 cars, but that this is made on a conservative basis is indicated by the fact that the average cost for the 23,692 passenger coaches is placed at only \$12,800. A steel car designer of some considerable experience estimates that steel passenger train cars can be built for about 12 cents per pound, as compared to about 2½ cents for freight cars. On this basis the Pennsylvania steel coaches, designed to seat 88 people, would cost about \$14,000. One steel car builder is authority for the statement that all-steel passenger coaches cost from \$14,000 to \$17,000 each, averaging about \$15,000. In the Interstate Commerce Commission hearing on the North Haven wreck General Manager Bardo submitted a list of improvements which the New Haven had made or authorized since August, 1911, in which 100 steel passenger coaches were listed at \$16,500 apiece.

If the roads could get together and order common standard cars the price might be made lower. The term common standard in this case does not refer alone to the type of framing and superstructure, but to the specialties as well. Builders experience serious trouble and delays, even if the general construction is similar, if a few of the specialties vary. This is evident in the experience of one important system which is now having built a large number of steel passenger coaches, which are almost identical except for certain specialties which are varied to suit the tastes and special requirements of different parts of the system. These changes, unimportant as they may seem, interfere with the output to a considerable extent, and particularly, when due to the delivery requirements, it becomes necessary to build the cars in small lots for each of the various divisions, instead of running all the cars for one division through at one time.

Builders will probably not allow the passenger car business to interfere with the building of freight cars. Building passenger cars is a slow process, and it is commonly reported that it is not nearly so profitable as the building of freight cars of an equivalent value. Whether they would care to extend their facilities at the expense of the freight car business or whether they could afford to greatly extend their steel passenger car building facilities is an open question. To build a new plant and install an efficient organization is a matter of at least a couple of years, and it is doubtful whether capital could be interested in such a hazardous venture, when the fluctuations in the railway supply business are considered.

**STEEL FRAME VS. ALL-STEEL CARS.**

Fire and splinters are the two great objections to the wooden cars in case of wreck. These are reduced somewhat with the

steel underframe car, and still more so with the steel frame car, which includes a steel underframe and a steel frame for the superstructure. This is particularly true of splinters, which are not nearly so serious where the heavy framing timbers are replaced by steel members.

One system which has a large number of steel frame passenger cars in service claims that this type "is very much superior to a large proportion of the steel equipment now being turned out, due to being lighter than steel and, also, to the fact that steel sheathing in itself is a safeguard only against fire and is not as good a protection, in the case of most of the accidents that happen on railroads, as steel underframes and framing properly designed. Our investigation indicates that steel equipment will be at least 20 per cent. heavier than coaches built to our present design. We have felt that the danger of fire from the locomotive can be largely eliminated by the use of steel mail cars which are placed next to the engine." The statement that steel equipment will be at least 20 per cent. heavier is questionable. The Pennsylvania, Oregon-Washington & Navigation Company, and the Southern Pacific passenger

and a better insulator. Probably on no question in passenger car design is opinion so divided amongst both railroad and car builders. There is today very little difference in cost, and it certainly appears probable that in the future the tendency will be to adopt steel interior finish if not entirely, at any rate to a great extent."

W. F. Kiesel, Jr., assistant mechanical engineer of the Pennsylvania, in speaking on this subject at the same meeting, said: "In the all-steel car the steel lining can be securely riveted to the framing and adds somewhat to the strength of the complete structure, but as steel is a good conductor, it carries away the heat of a body coming in contact with it, and, therefore, will always feel cold, even when the temperature in the car is sufficiently high. Satisfactory results have been realized from the use of a double steel lining between seats, forming a hot-air duct, extending from the heater pipes to the window sill, with outlet through small holes in the lining proper, located immediately below the window sill.

"Wood lining requires considerable wood furring, and adds weight to the car without adding to the strength. As the steel



The Crushing of the End of this Steel Car Absorbed the Shock and Protected the Body of the Car.

coaches have a dead weight per passenger of less than 1,400 lbs. It is doubtful if the first class wooden coaches which they replaced weighed much less than this. On the other hand many all-steel coaches are in use on other roads which have a dead weight of more than 1,700 lbs. per passenger. The extensive use of electric lighted cars also minimizes the fire risk.

President George F. Baer, of the Philadelphia & Reading, was widely reported to have made the following statement a short time ago: "By discipline—firm, rigid, unyielding discipline—alone can railroad wrecks be averted. I do not believe in all-steel cars. I think the half-steel cars are the safest. But steel cars will not prevent wrecks. Discipline alone can do that." This report as far as it refers to steel and part-steel cars is erroneous. The Reading has cars of steel construction in use and has others on order. True, these cars have an inside wooden lining, but this is used because it gives a more pleasing finish to the cars, does not affect their strength in the least, and is considered practically as safe as the all-steel construction. Many cars, classed as all-steel, are finished in this way.

Referring to the matter of inside finish for all-steel cars, H. H. Vaughan, assistant to the vice-president of the Canadian Pacific, in addressing a New York meeting of the American Society of Mechanical Engineers, April 8, 1913, said: "The preferable material for inside finish is a matter for future decision. With the ample protection afforded by a steel car against accident, there does not appear to be any objection to wood inside finish on the ground of safety. It is more ornamental than steel

frame of a long passenger car may vary as much as  $\frac{1}{2}$  in. between extremes of temperature it is necessary to make allowance in the construction of the wood lining for this variation in length. As a car with metal lining riveted to the framing has the advantage in strength, weight, and cost, it will gain in favor; in fact, it would be at present universally preferred if all railroad shops had practical experience with steel lining, and the necessary proficiency and machinery for its manufacture."

The following expression of opinion concerning the use of all-steel and steel underframe cars [not steel frame] is taken from the report of the New York Public Service Commission, Second District, on the Delaware, Lackawanna & Western rear-end collision at Corning, N. Y., on July 4, 1912: "Steel cars certainly appear to afford additional protection to life in accidents of this character, but there is room for discussion of their value as compared with wooden cars having steel underframes. Further and exhaustive examination of this matter is imperatively demanded. A large amount of progressive work has been done in this country in the construction of wooden cars, through close coupling vestibules and strong platforms, to reduce the danger in collision or derailment. The construction of American wooden cars appears to be far superior in safety to the passenger cars used in England or in Europe generally, and the efforts to afford safety and comfort in the car construction of this country as compared with foreign practice is indicated by the great weight of American equipment in pro-



portion to passengers carried. The indications are, we think, that the use of steel cars will increase rapidly in this state through the ordinary processes of addition and replacement, and through the necessities of electric operation in tunnels such as those at New York."

H. H. Vaughan, in speaking before a New York meeting of the American Society of Mechanical Engineers on April 8, 1913, said: "The steel underframe does not appear to be a satisfactory or permanent development. There is but little saving either in weight or cost over the all-steel construction, and it is difficult to see how the same strength in case of accident can be obtained. Experience will show whether the wood superstructure can be secured in such a way as to prevent working as the car gets old, but as it cannot be arranged to carry any weight, this appears questionable. It can hardly be regarded except as an intermediate step between all-wood and all-steel construction."

In the Interstate Commerce Commission hearing on the North Haven wreck General Manager Dean of the Pullman Company stated that the first all-steel Pullman cars were completed in February, 1910. He also stated that the all-steel car was unquestionably stronger than cars of other types and with the all-steel car properly reinforced at the end it is the most advanced type of car manufactured at the present time. In his opinion, the steel underframe car having wooden posts was not as strong or as safe as the all-steel car with steel posts, due to danger in collision of a car overriding the steel underframe and telescoping the car body.

There seems to be a considerable difference of opinion as to the relative weight and cost of steel and wooden cars. Mr. Vaughan, in referring to the weight, said: "With equal strength of side framing the side-girder car may be made lighter than the center-girder type, and the weight of steel passenger cars is one of the most serious problems to be faced by any railroad not having a level line. American passenger equipment was already excessively heavy per passenger carried with wood construction, and the use of steel has increased this weight from 10 per cent. to 20 per cent., which is a most serious matter. Apparently side-girder cars as so far constructed have a decided advantage over the center-girder type in their light weight and greater strength in case of accident tending to crush in the side of the car. This will probably lead to the use of this type on roads on which weight is of importance."

The claim is made by some designers that a steel underframe car, compared to an all-steel car of equal strength, is heavier and will cost as much or more than the steel car. It should be noted that Mr. Vaughan compares the all-steel car with the wooden one, and not with the steel underframe car. In speaking of the comparative cost of steel and wood cars W. F. Kiesel, Jr., assistant mechanical engineer of the Pennsylvania Railroad, said: "Those who have been in close touch with the development of the steel car industry know that at the present time steel cars cost and weigh no more than equivalent wood cars."

While the Interstate Commerce Commission has made several recommendations as to the use of steel cars, it has nowhere defined the meaning of that term. Steel underframes and steel frame cars both have strong advocates. A study of the reports of wrecks made by the Interstate Commerce Commission indicates that steel underframe cars have given a good account of themselves. The difficulty with this construction, as suggested by Mr. Vaughan, is properly to tie the superstructure to the underframe. With a steel underframe and a reinforced end construction, however, such cars are probably as safe from telescoping as some of the steel cars which have been built. The elimination of the heavy wooden sills reduces the risk from splinters to a great extent.

On the other hand, the steel frame car will undoubtedly be classed as a steel car, for with its steel framework, and proper attention to the construction of the hoods and end frame to

prevent telescoping it can be made of sufficient strength to insure safety, the danger from splinters will be practically eliminated, and the risk from fire will be greatly reduced.

#### ARE STEEL CARS NEEDED?

While steel passenger train cars may be desirable from many points of view, there is a considerable question in the minds of many as to the advisability of unnecessarily expending money for them when it might far better be spent in other ways which will go to the very root of things and eliminate the causes which are responsible for the accidents. After all, the number of lives that may be saved by the use of such equipment is only an extremely small percentage of the lives lost annually on railroads. For instance, for the year ended June 30, 1912, 318 passengers were killed and 16,386 injured, while 3,235 employees were killed and 50,079 injured, and 6,632 other persons were killed and 10,710 injured. Only 3.1 per cent. of those killed and 21.2 per cent. of those injured were passengers, and this is the class to which the introduction of steel cars will be of greatest benefit. Furthermore, less than one-half of the passengers killed were in collisions or derailments. The others were killed or injured largely because of want of care on the part of the victims themselves.

Many roads are now using all-steel cars on their high grade passenger trains. The railroads generally have practically stopped building wooden cars, none having been ordered during the first six months of the present year. Although the first experimental passenger coaches for steam roads were not built until 1906, and it was not until the middle of 1907 that the Pennsylvania Railroad placed the first large order for such cars, on January 1, 1913, over 12.6 per cent. of the cars on roads covered by Bulletin 53 of the Special Committee on Relations of Railroad Operation to Legislation were all-steel and 4.6 per cent. were steel underframe construction. Surely this indicates a purpose on the part of the railways to take full advantage of this construction, particularly when we consider that it is still considered by some to be in an experimental stage, and that until comparatively recently we have had no idea as to how it would behave in wrecks. Even today our knowledge in this respect is very limited.

If laws are to be enacted forcing the roads to equip with steel passenger cars, it would hardly seem necessary, or even advisable in many cases, to require such cars except on roads or divisions where the traffic is heavy and is operated at high speed. Where trains are operated at slow speed, or are few in number and small, as they are on many roads or on some divisions and branches of large systems, it is useless to require all-steel cars. The money could be far better spent in providing safeguards to prevent accidents. The better class wood cars now in service could be used in these cases until it became necessary to replace them, or until such a time as the traffic increased to a point where it became advisable to transfer or take them out of service.

It must be ever kept in mind that steel cars will not prevent wrecks. The *Literary Digest* stated the case aptly in its issue of October 4, when it said: "As no wreck was ever prevented by steel cars, some observers are asking just now if the popular craze for these vehicles would not be better directed toward the elimination of causes of accident, instead of taking it for granted that every train will some day go to smash, and building it like a safe-deposit vault. One editor inquires if it wouldn't be better to insist that there be no collisions of trains of whatever material rather than to rest content with steel cars to make collisions perfectly safe and customary."

The New York Public Service Commission, Second District, in commenting on the cost of replacing wooden cars by those of all-steel construction, said in its report on the Corning, N. Y., accident: "The enormous cost which would be required to replace the present equipment of wooden cars in advance of the natural movement in that direction, coupled as it would be

more or less with a diversion of funds needed for the prevention of accidents; to a purpose that only minimizes the effect of accidents which ought not to have occurred, is one of the considerations to be given proper weight in the study and investigation which we strongly favor."

It is a matter of common knowledge that the managers of most of the large railways would today appropriate many millions of dollars for automatic block signals, now generally acknowledged to be one of the most important instrumentalities in the prevention of collisions, if they knew how to raise the necessary money. Ten thousand miles of track need this improvement today.

Many millions are needed on every road for the elimination of grade crossings of highways. This is a matter in which the public is vitally interested, and yet when a railway makes an investment of this kind there is no increase in its receipts and little or none in the net results. In spite of the financial difficulties cities and towns are constantly forcing these expenditures on the railways. There are many other expenditures which are much more needed in the interests of safety than that for steel passenger train equipment.



Showing How the End of the Steel Parlor Car Was Crushed In at the Tyrone, Pa., Wreck.

The report of the Rail and Equipment Committee of the National Association of Railway Commissioners contained this statement: "It must be acknowledged that the wheel weights now being used upon both cars and locomotives in the United States are so great as to be entirely without precedent in railroad history, and the combination of speed and heavy wheel weights, together with the extremely severe track conditions frequently met in winter operations in this country, produce conditions which are most difficult to meet."

#### BEHAVIOR OF STEEL CARS IN WRECKS.

Steel passenger train cars have given a good account of themselves in wrecks. The conditions under which collisions and derailments take place vary so widely, however, that it is difficult to secure a fair comparison of the behavior of wood,

as compared to steel cars. Three wrecks have occurred within the past six months which may prove of interest as affording such comparisons.

H. W. Belnap, chief inspector of safety appliances, in his report of a head-end collision between two passenger trains on the Missouri Pacific at Brant, Mo., May 27, 1913, said: "This accident affords exceptionally interesting opportunity for comparison between wooden and steel equipment. Both trains were traveling at about the same rate of speed, and one had a wooden car immediately behind the locomotive, while the other had a steel car in a similar position. The wooden car was completely wrecked and was destroyed by fire which broke out afterwards, while the steel car was badly damaged only on the end adjoining the locomotive, even the window glass in the other part of the car not being broken; all this notwithstanding the fact that the steel car had the weight of six cars behind it, while the wooden car had the weight of only four cars."

Within the past four months two wrecks have occurred, one with wooden cars and the other with steel cars, in which the conditions were quite similar. In discussing the New York, New Haven & Hartford rear-end collision at North Haven, Conn., on September 2, 1913, the Interstate Commerce Commission report contains this statement: "It is interesting, however, to note the contrast between the condition of the wooden cars involved in this accident and the steel cars involved in a similar collision on the Pennsylvania Railroad at Tyrone, Pa., on July 30, 1913. In each case the speed of the approaching train is thought to have been about 40 miles per hour. In the Tyrone accident the train which was struck had just started from the station but had moved only about one car length, while in this accident the train which was struck was standing still. In this accident the two rear cars were completely demolished, the third car badly damaged, and 21 passengers killed. In the Tyrone accident, however, none of the cars were destroyed, although several were quite badly damaged on the ends, and none of the passengers were killed. The shock of the collision was absorbed by the crushing of the platforms and vestibules."

The Tyrone wreck was one of the most severe in which steel cars have been concerned and a study of the behavior of the cars is therefore of special interest. The accompanying photographs show how the ends of the cars were crushed in. A characteristic of the Pennsylvania steel car design is that it is of uniform strength for any cross-section throughout the length of the car. There are strong vertical members at the end to prevent one car from telescoping another, and the roof, in addition to being sufficiently strong to keep from collapsing when it is turned up-side-down, is so braced as to afford considerable resistance to end stresses.

With a construction of this type the car will start to give way at the point of impact, as it would in any other case, but the heavy vertical members and the manner in which they are tied to the framework, together with the roof braces, cause a sort of pulling-in effect, drawing the roof and side framing inward, into the zone where they offer the most resistance, giving the damaged end a "mushroom appearance." While the force of the blow is first communicated to the small areas of the ends which may be in contact, and these parts crumble and give way, it is quickly transmitted to the other parts of the structure which offer more and more resistance as the stress is distributed throughout the whole cross-section, until the force of the blow is entirely absorbed. In other words, the blow is cushioned by offering a yielding resistance sufficient to absorb the shock while the end is giving way, thus protecting the body of the car.

There are other steel car designers whose views differ greatly from those of the Pennsylvania engineers. Their recommendations vary all the way from providing a special collapsible vestibule to absorb the shock and protect the body of the car, to using an extremely heavy end construction. If the cars are made too strong, so that some part will not give way and ab-

sorb the shock, the lives of the passengers will possibly be in as great danger as if the car was too weak. As the car will give way first at the point of impact, it is conceivable that the vestibule could be made considerably stronger than the cross-section through the body of the car, but the difference in strength should not approach the point where the body of the car will be in danger of crushing or crumbling.

Moreover, in designing such cars it is necessary to keep the weight as low as possible, consistent with safety. Otherwise the expense of operating the equipment will prove a burden. There is a considerable variation in the weight per passenger in the different designs of steel cars now in use, and more will have to be known about the behavior of the various types of cars in wrecks before the car which is to be perpetuated can be selected. It is not much of a problem to design a steel passenger train car which will operate safely. It is a tremendous problem to design one which at one and the same time affords ample safety and is the cheapest to operate and maintain; and although the steel passenger car is considered by many to have passed through the experimental stage, we have had such a limited experience with these cars in wrecks that possibly we are taking too much for granted in jumping to this conclusion.

#### VIEWS OF THE INTERSTATE COMMERCE COMMISSION.

The Interstate Commerce Commission, in response to a request from the House Committee on Interstate and Foreign Commerce for its opinion on a bill to require steel passenger cars, expressed itself as follows on June 24, 1911, and it is doubtful if it has had reason to greatly change its opinion since that time: "It is believed that the limit of time within which carriers should be prohibited from bringing into use new cars not in conformity with the provisions of the act should be approximately a year after the passage of the act or possibly a somewhat shorter period. This is suggested for the reason that there are doubtless many orders already placed and contracts in existence for construction.

"It seems to us that the period within which all carriers subject to the act should be required to bring into conformity all of their equipment of the kinds designated with the requirements of the proposed act should be extended somewhat beyond that suggested in the bill, and perhaps ought to be not less than about 10 years from the passage of the act. This suggestion is made because of the knowledge that at the expiration of a shorter period of time there would still be many cars capable of as satisfactory service as they are now, and that to put them out of service altogether in a less period than that suggested would entail a very heavy loss upon the carriers and would deprive them of the use of cars approximately as good as many of their standard cars now in use.

"It is believed that even at the end of the 10-year period suggested there would be many cars available for further valuable service with reasonable safety, especially on minor roads where few and small trains are operated and for short distances. This would be particularly true with respect to cars of special construction and strength, such as Pullman cars. For these reasons it is also believed that the commission should be vested with authority, in the event the bill is enacted into law, to extend the period of time within which particular carriers might continue the use of cars, also the time within which any carrier might be permitted to use particular cars which might at that time be deemed by the commission to be reasonably safe upon such investigation or inquiry as might in its judgment be necessary."

It is interesting to note that within less than 19 months after this expression of opinion the railroads, which furnished data for Bulletin 53 of the Committee on the Relations of Railway Operation to Legislation, had entirely stopped ordering wooden passenger cars.

Chairman Clark, of the Interstate Commerce Commission, in writing to a member of the Committee on Rails and Equipment of the National Association of Railway Commissioners, recently said:

"If a meeting of this committee had been held I am sure I should have been disposed to urge consideration and treatment of the subject of steel cars in the report. Our commission has officially expressed the view that from a given reasonable date, which would permit completion of cars under construction, no new cars should be put in passenger service except all-steel cars, and that from some reasonable later date, no cars, except all-steel cars, should be used in passenger train service.

"Investigations of wrecks which we have conducted have impressed us strongly with the conviction that steel passenger train equipment affords better protection to passengers than has ever been afforded by any other equipment."

#### CONCLUSIONS.

In conclusion it must be admitted that the steel car thus far has shown itself to good advantage in wrecks, although experience in this respect has been very limited and it is not known surely how the different types of construction now in use will compare and which one, if any, should be perpetuated. The steel underframe car, and more particularly the steel frame car, may be made as strong as the all-steel car and, because of their behavior thus far will probably be included under the classification of steel cars, if action is taken to force the railroads to adopt such equipment.

The steel car cannot prevent wrecks and the great expense involved in prematurely replacing wooden equipment with that of steel construction is hardly warranted when we consider other ways in which the money could be spent to better advantage in providing for the safety not only of the passengers, but of employees and others. Meanwhile the roads have shown a disposition to install steel cars as fast as the wooden ones need replacing and under normal conditions, without placing a heavy financial burden on the roads, the greater proportion of passenger train cars, particularly for high speed and heavy traffic, will be changed to steel within a reasonable period, whether action is taken by the government or not.

As public service commissions and regulating bodies have gained in experience and knowledge they have been forced to a realization of the necessity for careful and conservative action in dealing with important problems of this kind which require expert advice and which may affect adversely the interests of every individual in the community if not properly dealt with, and it is not likely that Congress will care to assume the responsibility of drastic action. Chairman Stevens, of the sub-committee of the Committee on Interstate and Foreign Commerce, is putting all the energy and study possible into trying to solve the problem for the best interests of all concerned. It is true that he has been spoken of in his own state as a "railroad baiter," but one knowing the circumstances under which he earned this title must recognize that it is undeserved and that his only concern is to bring about such legislation as will produce the best and most far-reaching results for the country at large and for the railroads, for their interests are the same and the welfare of either one is dependent on the other.

The sub-committee expects to hold hearings on this question at which all parties interested will be given an opportunity to express their views. A hearing had been set for October 16, but it was not possible to secure a quorum of the members of the sub-committee, and it was decided to postpone further hearings until November. Undoubtedly no action will be taken during the present session, although it is quite probable that the committee will attempt to cover the subject thoroughly with a view to making recommendations to be acted upon as early as possible during the regular session, which begins December 1.

CANTON-HANKOW RAILWAY, CHINA.—Survey work was resumed in June last, since when the whole route of the railway has been resurveyed from Wuchang to Yochow, a much better alinement has been obtained, and a saving in length made of slightly more than 11 miles compared with the original survey. The line as finally laid down will pass some 3 miles to the east of Chengling.

**WILLIAM C. BROWN.**

At the meeting of the boards of directors of the New York Central & Hudson River, the Lake Shore & Michigan Southern, the Michigan Central and the Cleveland, Cincinnati, Chicago & St. Louis on Tuesday afternoon, W. C. Brown tendered his resignation as president of the New York Central lines in the following letter:

"I have for two years contemplated asking to be relieved of the very exacting duties and responsibilities of the position of chief executive of the New York Central lines.

"I have been in railroad service continuously for more than 44 years—12 years of this service with the New York Central lines, five years in charge of operation and maintenance of the property, two years as senior vice-president and five years as president—and I feel that I have earned that freedom from care, hard work and responsibility which can only be secured by retiring from active service.

"In addition to my desire to be relieved of the burden and responsibility of my position, I am admonished by my failing hearing that I cannot, without serious embarrassment, continue to perform the duties of the position, either in the board room or in frequent important conferences in which I must necessarily participate.

"For these reasons, I beg to very respectfully tender my resignation as president, effective January 1, 1914.

"In leaving the service, I desire to express my sincere and grateful appreciation of the cordial co-operation which has always been extended to me by this board, and of the loyal, intelligent, and efficient support and assistance rendered by all the officers of the company."

The board, in accepting Mr. Brown's resignation, adopted the following resolution:

"This board accepts with regret the resignation of President William C. Brown. When he joined our system he had been for 32 years in active railroad work. He had risen from the bottom through every grade of operation and administration to the highest division in the important lines with which he was connected.

"His demonstrated ability as vice-president and general manager of the Lake Shore led to rapid promotion.

"He had won all these positions through a wide and varied experience, hard work, and close study. He was unusually equipped for its great responsibility when he came to be the executive head of this system. He has kept harmony while maintaining discipline and efficiency with this great working force.

"Under his administration the relations have been cordial between the railroad and the people in the territory it serves. The business of the system has doubled in revenues and tonnage. The vast construction and engineering work in the remodeling and remaking of the New York terminal and station has been uninterruptedly carried on, and railway operators at home and from

abroad have expressed their admiration that difficulties have been so overcome that train service has been maintained, that the electrification of the service in and about New York has been carried to completion without delaying or retarding the building of the engineers, architects, and contractors.

"Mr. Brown has been a pioneer in economic experiments for the increase of the output of the farms at the expense of, and under the management of, the railroad company. It brings the railroad and the farmer together for their mutual advantage. At threescore, and after 44 years of unremitting labor in his chosen profession, Mr. Brown has earned the privilege of retirement from the active and exacting responsibilities.

"He leaves this company carrying with him our highest respect for him as an official and our warmest regard for him as a man. May he enjoy long years of health and happiness."

Mr. Brown has been president of the New York Central lines

just five years. His most conspicuous work has been his relations with the public and his efforts to bring about a better understanding between railroad officers and their patrons—the public. A courteous man himself, he did a good deal to improve the New York Central's relations with the public which it served. He had a hard task. The New York Central's traditions were against him in this respect, and he inherited an organization which was hardly comparable to that on other of the strong American railroads. He studied diligently the problems of his lines, and left them in a better situation than when he came to them. He was not the man to take an uncompromising attitude toward labor unions; he was possibly too kind-hearted a man for this.

Mr. Brown was born in 1853 in Herkimer county, N. Y. He has worked his way up with no other help than the strong constitution and mental capacity with which he began life. He is a studious man, clear headed, with retentive memory, and learns a new thing quickly. It follows that he is an accurate judge of men and of subjects. He began railway work when he was 16

years old. For a year he worked as a section hand and fireman on the Chicago, Milwaukee & St. Paul. He learned telegraphy and was made a telegraph operator. After two years he went to the Illinois Central as a train despatcher, and served in this position later on the Chicago, Rock Island & Pacific and on the Chicago, Burlington & Quincy. He was made chief train despatcher on the latter road in 1880, and in 1881 was made train-master. He was appointed assistant superintendent in 1884, and superintendent in 1887. In 1890 he was appointed general manager of the Hannibal & St. Joseph and the Kansas City, St. Joseph & Council Bluffs, both part of the Burlington system. In 1891 he was made also general manager of the Chicago, Burlington & Kansas City and the St. Louis, Keokuk & Northwestern, and in 1896 became general manager of the Chicago, Burlington & Quincy. In July, 1901, Mr. Newman, then president of the Lake Shore & Michigan Southern, brought Mr. Brown to that



Copyright, Pach Bro., N. Y.

W. C. Brown.

property as vice-president and general manager. At this time Mr. Newman had just been made also president of the New York Central & Hudson River, and he chose Mr. Brown as the man to be left in direct charge of the Lake Shore. He had previously worked with him for a number of years. This recognition of Mr. Brown's value is particularly striking, as Mr. Newman's action was an exception to his long-established policy of never bringing to a property an outside man. A few months after he came to the Lake Shore, Mr. Brown was made also vice-president of the New York Central & Hudson River, and later his authority was extended over other New York Central lines. He succeeded Mr. Newman as president in 1909.

## HAS THE INTERSTATE COMMERCE COMMISSION'S SYSTEM OF ACCOUNTS MET THE NEEDS OF THE COMMISSION?\*

BY WILLIAM E. HOOPER.

The first idea of the Interstate Commerce Commission in formulating the system of accounts which it prescribed for railroad companies was to make a clear distinction between investment in the property and the expenses of running the property and to compel uniformity in this regard. The next step—the one which the commission is about to undertake—is that of showing the cost of different classes of railroad service. The experiences of the commission in its endeavors to regulate railroad rates are ample justification for an attempt to get this information.

The one definite restriction that the courts have placed on the power of the Interstate Commerce Commission to reduce rates or to order additional service is that such orders shall not deprive the railroad company of a fair return on the value of its property. The courts have never placed a limitation on the amount of profit which a railroad company might earn except this minimum, below which the legislature or commission could not make reductions. When the commission began, therefore, to issue orders reducing rates, the easiest defense which the railroad lawyers found against such rate reductions was the plea that these reductions deprived the company of a fair return on the value of its property. Incidentally it might be mentioned that a good many railroad men have serious doubts as to whether this defense was the best one that could have been found. A lawyer, however, is engaged in winning the particular case on which he is employed and not on the establishment of a sound economic theory of railroad rates. But by interjecting this question of cost of service into railroad rate controversies the lawyers have made it incumbent on the commission to make an investigation of their own into this question. The trend, therefore, is at present to attempt to show value of railroad property and cost of railroad service, but the rather unfortunate fact is that it is inherently impossible for accounts alone to show value of property, and so far the students of railroad accounting have not devised any satisfactory method by which the cost of service may be shown. Thus, while accounts can show cost of assets, not value, rates in actual practice are based rather on value of service than on cost of service. But regardless of the facts, the commission was compelled to follow the practice of the courts and to do their best to ascertain the value of the assets and the cost of the service. The Interstate Commerce Commissioners were neither accountants nor practical business men, but as lawyers they recognized that if they were to have their decisions sustained by the courts, they as well as the railroad officers must have at their disposal figures which could be used as a basis for determining the two factors which the court held as so necessary in the deter-

mination of whether or not a given rate was confiscatory.

This was very apparent at the hearing last Monday on the new form of annual reports. The railroad accounting officers protesting against any attempt to separate freight and passenger expenses, were able to show without the shadow of a doubt that it was theoretically impossible to accurately separate freight and passenger expenses. They knew so much more about their subject than the commission that, even where they were in the position of only being allowed to answer questions and not ask them, they could argue the commission to a standstill, but when all was said and done, when the smoke cleared away, the commissioners were found sticking to the one hard and fast fact of which they were sure, and that was that the courts had held that the value of the property employed and the cost of the service were two all important facts in the determination of whether or not a rate yielded a fair return on the property used in public service, and that being so, it was the commissioners' duty to try to ascertain these two facts. Furthermore, they appeared to be determined that they would not let the railroad companies wait until a particular controversy had arisen and then bring forward their figures to show cost of service, but would insist that some method of allocating costs, at least as between passenger and freight service, be adopted while there was no specific controversy going on. This, of course, is a later development of the original idea underlying the formulation of a system of railroad accounts, and when Professor Henry C. Adams was appointed statistician to the commission, his primary task was to have the railroad companies report figures which would show clearly the distinction between expenses of operation and property investment. Neither the commission nor Professor Adams, however, were so shortsighted as to ignore the fact that any system of accounts which they might prescribe should not only serve the purposes of the commission, but should also serve the purpose of the railroad managements, and Professor Adams and the commission have worked in conjunction with a committee of the American Railway Accounting Association, so that the present system of accounts represents something of a compromise between the railroad accountants' and Professor Adams' theories of accounting and the commissioners' own views of what ammunition they might fairly expect the accounts to furnish them with.

The Interstate Commerce Commission could not go back and recast all of the accounts of the railroad companies for past years. They therefore simply drew a line through the year 1907 and said, "From here on the accounts shall show the cost of all additional property acquired; in other words, the further investment in the property." They have succeeded in persuading Congress that a sort of post mortem of the railroad companies' accounts before 1907 shall be made through the so-called physical valuation of the railroads. However, that is another very different story. What we are concerned with, is to see how well the accounts kept in accordance with the commission's rules since 1907 make this distinction between the cost of running the plant and keeping it in repair, and further capital (property) investment.

Let us use certain words in a special or technical meaning. All outlays of money we will call expenditures and will restrict expenses to the cost of running the railroad plant and cost of its current upkeep. By additions and betterments we will mean expenditures which are a further investment in the property. Of course, there are other expenditures, such as interest payments, distribution of profits, etc., which come neither under the head of expenses nor of further investment in the property. Since this distinction between expenses and capital expenditures—additions and betterments—is one of the fundamental conceptions of the Interstate Commerce Commission's classification, the commission's instructions for charging expenditures to the various expense accounts are minute to a degree. In its instructions as to what

\*From a lecture delivered before the Graduate School of Business Administration, Harvard University.

to charge to station supplies and expenses, the commission lists a couple of hundred articles, as, for instance, ice, ice barrels, ice boxes, ice buckets, ice carts, ice tongs, and so on.

Running expenses, or, as the Interstate Commerce Commission calls them, transportation expenses, are easily recognizable as such. There might be some question as to whether certain station supplies were a part of the upkeep of the plant or a part of the transportation expenses, but no one could question that they were not additional investment in the property. The commission considers them transportation expenses. Just where to draw the line, however, between cost of upkeep—which the commission calls maintenance of equipment and maintenance of way and structures—and additions and betterments is sometimes a difficult problem. Apparently the dividing line which the commission has aimed at is the test as to whether or not the expenditure is made to keep the property investment intact, which does not necessarily mean that the earning power must be kept intact. To keep the property investment intact each part of the plant must be kept in repair, and when no longer serviceable to perform its proper work and incapable of being repaired, it must be replaced. Renewal in kind, whether it be a tie, a bridge, a valve gear or a freight car, is plainly maintenance, and as such is an expense and not a property investment. But the commission insists that where a renewal is accomplished not by a replacement in kind, but by a replacement with a part which will do the same or better work, and which is more expensive, the cost of this new part shall be split up and part of it charged to expenses and part to capital investment. So much of the expenditure as represents what would have been the cost of renewal in kind is charged to expenses, the remainder is charged to capital (property) account. This is what the commission means by keeping the property investment intact, and it will be clear that it is not necessarily keeping the earning power of the property intact. With the progress of the science of railroading, with the growth of competition and with the changing demands of the public served, it may be necessary to add quite materially to the original property investments in order to keep the earning power of the property intact.

Although there was at first a good deal of opposition on the part of railroad men and, as was to be expected, the opposition came from both the poor roads and the rich roads from two opposite reasons, to this rigid and, what seemed to practical railroad men, theoretical distinction between expenses and capital expenditures the principles laid down by the commission are now pretty generally accepted and approved of. There are certain difficulties in carrying out these principles, however, that the Interstate Commerce Commission system of accounts did not succeed in overcoming.

The management of a railroad company is very human. There is no scientific basis on which a roadmaster can tell the exact day, month or even year in which a tie or a rail needs renewal; the same is true with ballast and, as far as that's concerned, with freight cars. There is no scientific rule by which a man can tell when he needs a new suit. If he is making money he decides that his old suit can't possibly be used for another season and he orders a new one; if he is in hard luck, the old suit is plenty good enough for another season. Railroads are run on much the same basis. Cars and locomotives can be kept in service for a long time if the road cannot afford to replace them. In other words, the commission's system of accounts does not prevent a management from either starving or fattening up the property. The commission is also faced with this problem. A company buys a locomotive costing \$20,000. Its upkeep, that is, renewal of small parts, current repairs and every so often general repairs, costs on an average \$2,500 a year. At the end of 15 years the locomotive is obsolete and a new locomotive must be bought to replace it. In practice, of course, the new locomotive costs more than the old, but the

commission's accounts provide for this by charging to expenses only the \$20,000 which would have been the cost of replacement in kind. But here we are charging in one year \$20,000 to renewals of locomotives on account of this locomotive, where for the past 14 years we have made charges to repairs only with nothing for renewals. This is seemingly an unfair burden on this year's expense accounts. To get around this the commission prescribed depreciation accounts for equipment and instructed the railroad companies to make an estimate of the life of their equipment and to charge each year to expenses—depreciation—a certain per cent. of the cost of equipment, so that by the time the locomotive or car under normal conditions was ready for the scrap heap, an accumulated charge would have been made large enough to pay for a new locomotive or car. But the commission did not attempt to prescribe at what rate depreciation should be figured, nor did it provide that any actual fund should be created in which the moneys charged over a series of years should be placed. By following the commission's rules the road that had the \$20,000 locomotive which it scrapped, at the end of 15 years would have charged out 14/15 of the \$20,000 before the last year and would have needed to charge to the last year's expense only 1/15, but it would not have had about nineteen thousand dollars in its treasury specifically set aside for the purchase of a new locomotive.

Furthermore, the commission, by not prescribing any rate at which all roads must figure depreciation, has made an exception to its general scheme of uniformity, and thus where one road may figure depreciation on equipment at 4 per cent. of its cost, another road may charge each year but 1½ per cent., and while the companies must explain to the commission in their reports what basis they figure depreciation on, the general public and the security holders have no way of knowing unless they go down to Washington and consult the files of the commission.

Nevertheless, the commission is apparently well satisfied with its own rules for charging depreciation, for while in the system of accounts which is now in use, depreciation is allowed for on equipment only, the newest tentative draft of a classification of operating expenses which the commission has sent to the roads for their suggestions provides for depreciation on every class of material used in maintaining roadway and track, which, of course, includes stations, railroad buildings, etc., and in this newest classification the roads are again left to figure depreciation on any basis which they see fit.

Of course, every once in a while it becomes expedient to entirely abandon a piece of property. A road which was built around a hill may be abandoned and a tunnel driven through the hill. Is the cost of this piece of road that is abandoned still to be carried as an asset on the company's books? Is the cost of building the tunnel to be considered in the nature of replacement of the old line and, therefore, charged to expenses, or is it to be considered an addition to the property and charged to capital account? It is obvious that no depreciation charge can cover a case such as this. It is also plain that the cost of driving a tunnel through the hill over and above what it would have cost to rebuild the old line in the same location is an additional investment in railroad property, but the rub comes when we try to decide how to charge the expenditure which is made on the tunnel but which is equal to the cost of the old line; or rather, and this is the way the commission viewed it, what shall be done with the cost of the old line if the total cost of the new line is charged to capital (property) account?

If a railroad is originally built almost without grading across a piece of rolling country, and later the company decides to make cuts across the hills and fills in the valleys so as to reduce the grade from, we will say, 1 per cent. to a maximum of two-tenths of 1 per cent., the entire cost of the cuts and the entire cost of the fills may, under the Interstate

Commerce Commission's rulings, be charged to additions and betterments, but if a company abandons an old line with two 10 deg. curves in it by building a new line cutting across these curves on a tangent, under the commission's rules the entire original cost of the curved line must be charged to expenses. This is approximately the case which is now being considered by the Supreme Court on an appeal by the Kansas City Southern from a ruling of the commission. The railroads in this case claim that it is entirely illogical and unfair to permit the abandonment of a line vertically, while refusing to permit the abandonment of a line laterally. It is the contention of the Kansas City Southern that they should at least be permitted to charge the cost of this old line abandoned laterally to profit and loss, and I rather think that the commission is not unalterably opposed to the railroad's contention. However, this and the question of depreciation are both questions of detail.

In the main, the commission's system of accounts serves the purpose of the commission admirably insofar as it makes the necessary distinction between expenses and additional investment in the property. The difficulties mentioned are troublesome and in certain cases the hard and fast requirements of the commission are working an injustice, but it is only a question of time until these difficulties are overcome and the main question involved is being successfully solved by the commission.

The case is entirely different with the determination of cost of various classes of service. I suppose it would be heresy to suggest that there is the faintest doubt that cost accounting is and should be the goal of all business accounts, but it is both safe and fair to say that the commission, Professor Adams, the present statistician Mr. Meyers and the committee of eight of the American Railway Accounting Association have not as yet devised a system which can be applied to railroad accounts in such a way as to show, even with a fair degree of accuracy, the cost of various classes of service or even of specific services. One reason for this is that no one has as yet suggested a unit on which we could measure railroad service. Complicated as are the manufacturing operations of such an establishment as the packing business of the Armour's, with its multitude of by-products, it is possible to enumerate all of the various products which the business turns out and so get a list of the units which can be used in making an analysis of the work done to produce these units. The manufacturing costs of glue, fertilizer and hides, while all intricately related to the cost of butchering cattle, are in the final analysis the costs of manufacturing certain definite products. Glue is glue, but it was a railroad man who demonstrated that in his business "pigs is pigs" is a fallacy.

The commonly accepted measure of railroad service is the transportation of a ton of freight a mile or of a passenger a mile. But a ton mile is like a statistic with a capital S; it does not exist, or at least there is an infinite variety of them, and furthermore there is no necessary relation between ton miles and dollars and cents. You may say that this is true also of a quart of glue, but as a matter of fact, the variation in the price of glue is comparatively small, while the variation in the price of a ton mile is infinite. If this is so with the price which may be charged for a ton mile, it is even more true with the cost of producing a ton mile. In every haul of freight there is involved a terminal cost at either end, a road movement cost and an overhead charge. In most cases there is also involved a yard expense. These four classes of cost are as intimately and about as simply interrelated as the parts of a Chinese puzzle. To this is added the complication of passenger business, which itself is made up of overhead cost, terminal cost and road movement cost, and in some cases and to some extent yard cost.

But to go back to the ton mile. A ton mile of feathers

packed in pasteboard boxes, even when these pasteboard boxes are crated, is very different, both as to cost of service and value of service, from a ton mile of coal, but 100-ton miles of coal which involves a large terminal expense at both ends and a yard expense and 100-ton miles of coal which is made up only of road movement expense, are quite different, at least as to cost of service, one from the other. If we are to continue to use the ton mile and passenger mile as units of service, it would seem as if the most obvious grand divisions of railroad operating expense would be, first, as between passengers and freight; second, as between materials and labor, and third as between overhead, terminal, yard and road movement expenses.

In the classification now in effect the commission has made no attempt to separate the cost of freight and passenger business, no attempt to separate the cost of materials and labor, and only a partial attempt to separate the overhead, terminal, yard and train movement expenses.

In the tentative classification which the commission discussed last Monday an attempt has been made to show separately in the reports which the roads are required to make to the commission, expenses which are incurred for the movement of freight exclusively, those that are incurred exclusively for the movement of passengers, and those that are joint expense. This is the most radical change from the classification now in effect, and although railroad accountants have rather opposed any attempt on the part of the commission to order the roads to make this assignment of expenses, they have been themselves for a number of years attempting to make it for the information of their own management, and the commission is following and not leading in this respect so far as the railroads are concerned and taking the position imposed on them by law as they see it of leading so far as the courts are concerned. I personally think that on a given division of a road, a study of conditions can be made which will form the basis of a fairly accurate division of passenger and freight expenses. I do not say costs. It is impossible to allocate to passenger service all of the costs for which this service is responsible. For instance, how can we possibly make any estimate of fuel that is burnt by a freight locomotive while standing on a siding waiting for a passenger train to pass? Yet if we are to strictly determine the actual cost of passenger service, fuel burnt by this freight locomotive should be charged to passenger service and not to freight service. The expense, however, is an expense incurred in freight service, and if we can separate, even with a fair degree of accuracy, the expenses of each of these two classes of service, we will have made a long step in advance. On the other hand, I do not believe that any general rules can be laid down which can be followed by all roads or even by different divisions of the same road to separate freight and passenger expenses. The commission is pretty surely working along the right lines in its latest classification of expenses, it seems to me, in this division of freight and passenger expenses, and by making haste slowly it is not only avoiding unnecessary mistakes and expense, but is materially helping the development of railroad operation as a science.

The classic example of the cost of fuel for the freight train standing on the siding waiting for the passenger train was given an added frill by one of the railroad accountants at the hearing on Monday by his further supposition that the freight train was made up of cars of mixed merchandise, with which there were interspersed three cars of company fuel to be used in both freight and passenger service. This last touch adds a bit of humor to the objection, but it does not seem to me to make the objection insurmountable. It would be easy to find examples in factories where cost accounting is being used with great apparent success of expenses such, for instance, as the surreptitious use of the long distance telephone by one of the

general bookkeepers for a private message to a friend, that could not be accurately allocated to the cost of any product or classes of products.

When we go further, however, than to try to separate freight and passenger expenses, and try to determine even approximately the cost of hauling a particular ton of freight between two specified towns, we get into the field of almost pure conjecture unless we are willing to accept averages for comparative purposes and guesswork founded on what has proved in the past sound judgment.

If one were to predict what the next step would be after a division of freight and passenger expenses I would say that it would be a division as between different classes of service. In other words, a partial abandonment of the ton mile and passenger mile as sole units of service. There is in passenger service, through express service, through local service, suburban service and commutation service, to name a few of the more important, but the classes of service are not infinite in number, and the same is true of freight service. There are expedite through freight trains which have to be run regardless of tonnage; there are slow drag freights which have to be sent out only when the locomotive is given its full rating, and so on. Working along these lines it might be possible to approximate a fair estimate of the average cost in each class of service. If we could get the Interstate Commerce Commission to make some sort of a binding confession of faith which would commit them irrevocably to the principle that value of service was a far more important factor in making rates and in the question of the reasonableness of rates than cost of service, and that they would use figures for cost of service only where the defense was set up that a reduction in rates was confiscatory, then I believe that the railroad accountants and railroad managers would be far more willing to help the commission in its efforts to do what it believes the law and the courts have imposed on it, namely, to get at some basis of approximating costs. The trouble is just this: The courts fixed a minimum below which rates could not be reduced. Legislators, the professional agitators and the political appointees on state commissions have tried to make it their business to make this also the maximum. The courts have never held that the minimum rate which was legal was a reasonable rate, and no thinking man who had the responsibility of managing a business would say that a bare minimum return on the business which would keep it out of present bankruptcy was a reasonable return, and yet that is the tendency in political agitations since the political agitator is not responsible and can't be held responsible. There is this danger in going to work to develop a cost accounting system for a railroad company in the present state of public opinion. If commissions—I do not say the Interstate Commerce Commission but rather state commissions—and political agitators are to be given the opportunity to pick out a particular service and say, "You are receiving a much higher rate on this service than it is costing you to perform this service; you must reduce it," and be able to go to the court and win that particular case, in time it is perfectly obvious that every rate which yields more than a slight margin above cost will be hammered down and the result, of course, will be utter bankruptcy.

**NEW LINE FOR RUSSIA.**—The construction of a railway line from Odessa, Russia, to Akkerman has been discussed for a number of years and the project now appears to have taken definite shape. The chief constructor of the proposed line has arrived in Odessa and many arrangements preliminary to commencing active work have been completed. A new building to be used for administrative offices is now under construction in Odessa and, under the present plans of the company, work on the new line between Odessa and Akkerman will be started early next year.

## A PLAN FOR THE JOINT PURCHASE OF FREIGHT CARS.

Newman Erb, president of the Minneapolis & St. Louis, has suggested a plan for financing the purchase of 200,000 freight cars through an association to which the railways of the country would subscribe \$25,000,000, the balance to be raised by the sale of equipment bonds. The plan is outlined by Mr. Erb in a letter to the *Railway Age Gazette* as follows:

"The present condition of the railroads has become alarmingly serious, and their credit is now impaired to the point where additional burden has been put upon them in the larger interest charges for their money requirements, difficult for them to obtain except through makeshift temporary loans, besides the increase in the cost of transportation.

"It appears to me that the nationalization of our railroads is inevitable if they are to meet the requirements of the future, unless they are placed upon an earning basis that will increase the factor of safety to investors and give them a stability which has been progressively undermined since the Interstate Commerce Commission was invested with authority to control rate-making, an authority which has since been exercised almost continually downward.

"Our railroads are obliged each to furnish a large proportion of cars for interline, interstate, and interchange traffic. Under existing conditions, the burden of supplying the equipment used for this tonnage movement should be borne in common by the carriers, and none of them should be individually burdened, under conditions that involve a strain upon their credit and prevent or embarrass them from readily obtaining money at reasonable rates for their local needs.

"It occurred to me, therefore, as it has to other railway executives, that a plan for an association, financed by the companies in common, for the purchase of equipment to be used in interline traffic would meet the present difficulty. Twenty-five million dollars, distributed in five annual installments of \$5,000,000 each, contributed by the railroads of our country distributed on a mileage basis, would mean \$20 per annum per mile for five years; or, if distributed on a tonnage-density basis, would still be unimportant and furnish within the period named enough to justify a credit of \$200,000,000, sufficient to purchase 200,000 cars.

"I am convinced that with the joint credit, 20 or 30-year serial equipment bonds could be marketed readily from time to time, and with the cars acquired, distributed as required by the association in control, they would earn through the per diem charge more than sufficient to pay the interest requirements, renewals, insurance, and principal.

"I have not elaborated the details of this plan, which I expect to do, however, but simply outlined it here, in the hope that its presentation may invite a discussion on the subject from those most interested."

**Buenos Ayres & Pacific Railway.**—This company controls the greater part of the international railway route between the capitals of Argentina and Chili by its operation of the lines between Buenos Ayres and the Chilian border. Its operation of the Argentine Great Western Railway gives it a valuable traffic in vine products. It also has a long lease on the Bahia Blanca & North-Western Railway, which gives it an access to another port, and it operates the Villa Maria & Rufino Railway. The total mileage operated is now 3,417 miles, an increase of 69 miles since the previous year. The results of the combined system during the year ending June 30, 1913, were, on the whole, distinctly satisfactory, and the increased dividend has been fully earned, without its being necessary to distribute profits up to the hilt. To some extent the increase in the earnings is due to a comparison with a period when traffic was considerably disturbed for nearly two months by the enginemens' strike. The period under review has, consequently, benefited by the carriage of wheat and maize delayed because of the strike.



## COMPARISON OF FREIGHT TRAIN AND CANAL BOAT RESISTANCE

BY HAROLD A. HOUSTON,

Mechanical Department, Rock Island Lines, Chicago, Ill.

Because of the recent discussion concerning the feasibility of the proposed Great-Lakes-to-the-Gulf deep waterway the writer has prepared the following few facts as an argument against such a waterway as is proposed when service and cost, from the standpoint of time and speed, are the paramount issue. The canal barge data was obtained from tests made with barges having capacities ranging from 137 tons to 1,041 tons gross displacement. Those made on the Burgundy, St. Dizier, De Jorgny canals and the River Seine were conducted by M. De Mas and those on the Dortmund-Ems Canal by Herr Haack, all in Europe. The data on the Lehigh Canal was obtained from tests made near Mauch Chunk, Pa.

The boats under test were in actual service, and the tractive effort was measured by inserting a dynamometer in the tow-

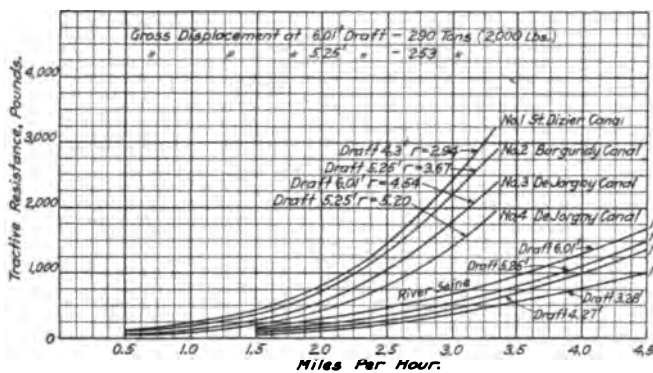

Fig. 1—Relation Between Tractive Effort and Speed for Flute Type Boat.

rope, which gave a direct measure of the resistance sought. The resistance thus determined is known to vary with skin-friction, coefficient of fineness, coefficient of displacement, ratio of canal wet-section to midship immersed cross-section of the boat, hereafter referred to as  $R$ , with wave action, with sunken water surface, etc. In the selection of data an attempt has been made to have these conditions comparable. The facts concerning the resistance of the trains were taken from the results printed in a bulletin published by the University of Illinois Engineering Experiment Station.

The experiments conducted by M. De Mas, Inspector General of France in 1895, and published as "Recherches Experimentales sur le Material de la Battellerie," is probably the best material to be obtained in regard to tractive resistance of the smaller type of canal boats. M. De Mas used a boat of the "Flute" type, 99 ft. long, 16.43 ft. beam, 6 ft. maximum draft, 290 tons (2,000 lbs.) gross displacement, having a coefficient of displacement of 0.952, and having a displacement of 9,270 cu. ft. This same boat was used for tests in the St. Dizier, Burgundy, and De Jorgny canals, and in the River Seine. The width of the Seine was 40 times the width of the largest boat, and the depth was three times the greatest draft, hence the value of  $R$  became so large that its effect in the boat action became negligible, or approached zero as a limit.

The results of these tests are shown in Fig. 1, where the tractive resistance as measured in the tow-line is plotted as ordinates against the speeds in miles per hour as abscissae. Curves Nos. 2, 4 and 6, wherein the boat has the same draft, but is operated in waterways of different cross-section, show that a decrease in the value  $R$  gives a greater tractive resistance for any constant speed. This statement is further amplified by the curves from tests in the River Seine. Here it is seen that the tractive resistance increases directly as the draft increases, but

as the draft increases, the ratio  $R$  decreases; therefore a decrease in the value  $R$  gives an increase in the tractive resistance for any constant speed. Hence, it would seem, that for efficient propulsion of a barge, the value of the ratio  $R$  should be as large as the conditions will justify.

Fig. 2 shows the relation between the tractive effort and speed for the freight trains and canal barges. Curve No. 1 is taken from experiments conducted on the Dortmund-Ems canal and represents the normal loading of the barges, giving a draft of 6.6 ft., 1,041 tons gross displacement. Curve No. 2 is also taken from experiments on the Dortmund-Ems canal with two barges in tow. It represents the normal loading of the barges, giving a draft of 6.6 ft. for 2,082 tons gross displacement, of 1,041 tons per barge. Curve No. 3 is taken from Curve No. 2 in Fig. 1, and represents approximately the normal loading. Curves 4, 5 and 6 are taken from experiments made on the Lehigh canal in the United States, and represent the resistance offered by barges in trains of 4, 2 and 1, respectively, each barge having a draft of 5.18 ft. for 137 tons of gross displacement. Curve No. 7 is taken from data obtained from the Tetlow canal (Europe) and is only approximate, due to three points only being obtained between the speeds of  $2\frac{1}{2}$  to 3 miles per hour. Curves 8, 9, 10 and 11 show the relation existing between tractive resistance in pounds per ton and speed in miles per hour for various weights per car in freight trains.

From this chart it will be seen that there is a point where the tractive resistance of canal barges is equivalent to tractive resistance of freight trains. It will also be noticed that below three miles per hour the barge resistance per ton is much less

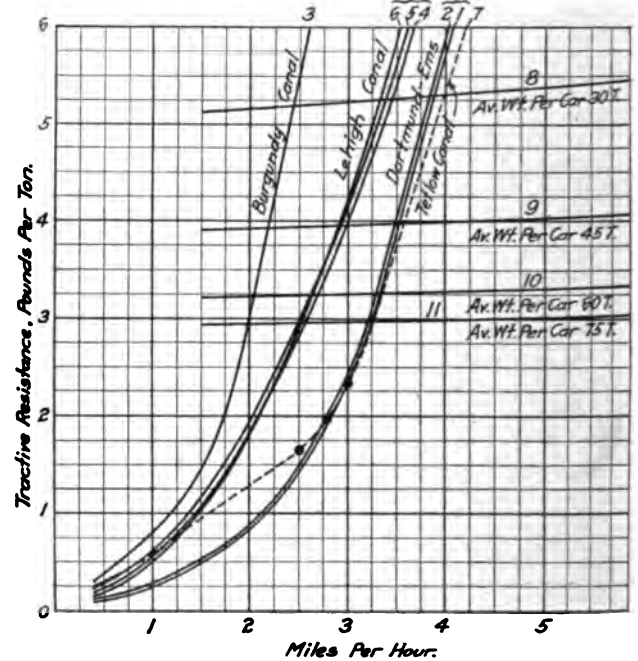

Fig. 2—Relation Between Tractive Effort and Speed for Freight Trains and Canal Barges. (One Ton=2,000 lbs.)

than that of trains, but that above that speed the freight trains have much the advantage. From previous experiments and reports there seem to be practical reasons, such as the washing of canal banks, etc., which prevent any material increase in the speed of the canal boats, and it is, therefore, under ordinary circumstances, neither desirable nor advantageous to attempt an increase in speed over a certain limit—say from 2 to  $3\frac{1}{2}$  miles per hour, the present average speed. The action of a boat in a canal is decidedly different from its action in open water, where the body of water is large enough freely to permit the water particles from every direction to fill in the void left by the boat. It is, therefore, to be expected that the resistance in a canal will be larger than in open water.

# THE STRIKE ON THE SUNSET LINES.

The Engineers, Firemen, Conductors and Brakemen Leave Service for Four Days. President Scott's Statements.

The engineers, firemen, conductors and brakemen of the Sunset Lines of the Southern Pacific went on strike on November 13 at 7 o'clock p. m. The strike involved the lines from New Orleans to El Paso, including branch lines in Louisiana and Texas, but did not involve the Houston & Texas Central and the Houston East and West Texas. The total mileage affected was about 2,400 miles. The strike was brought to an end on November 17.

The breach between the company and its employees was the result of a long series of disputes and negotiations pertaining chiefly to cases of discipline. On September 16, after having been negotiating with representatives of the Brotherhood of Locomotive Engineers, the Brotherhood of Locomotive Enginemen and Firemen, the Order of Railway Conductors and the Brotherhood of Railroad Trainmen, the company was notified of the formation of co-operative committees which had been formed to handle the grievances of the employees in both engine and train service.

The management indicated that it was willing, as it had been in the past, to confer with the representatives of the different organizations individually regarding grievances and other matters of interest to them individually, and to confer with them jointly regarding matters of interest to them jointly, but it refused to confer with them jointly regarding matters which were of interest and concern only to the individual organizations. In consequence, on November 12 notice was served on G. S. Waid, assistant general manager, that unless he consented to meet the committees in joint conference the employees concerned would withdraw from the service on November 13 at 7 p. m. Mr. Waid replied that as it seemed impossible for the company and the men to agree, the management, in the interests of all concerned, had formally requested the Federal Board of Mediation and Conciliation to use its good offices to, if possible, bring about an amicable settlement. No reply was made by the representatives of the brotherhoods to this communication, but on November 13 at 6:26 p. m., just 34 minutes before the time set for the strike, a communication from them was handed to W. B. Scott, president of the Sunset-Central Lines. This set forth that the employees had received a telegram from G. W. W. Hanger, assistant commissioner of mediation and conciliation, Washington, D. C., offering the friendly services of the board to bring about an amicable adjustment, and that the representatives of the brotherhoods had replied that they would not concede that the questions involved were a matter for mediation and conciliation and that they were "therefore obliged to advise that the only possible way to avert a strike is for the company to agree before 7 p. m. this date to meet our joint committee for the purpose of discussing matters of difference." No other move was made until the strike was declared.

The action of the employees came at a time when there were large crops of cane and other products awaiting movement on the Sunset lines, and owing to this and the precipitateness of the step taken—together with the fact that it was taken after the railway had appealed to the Federal Mediation and Conciliation Board and the employees had refused the intervention of that Board—public sympathy along the lines seemed to be with the management of the railway. The newspapers severely criticised the action of the employees. The strike was ended by the action of the management accepting the proposal of the Federal Board of Mediation and Conciliation that it meet the committee of the four unions, with the understanding, however, that if no agreement can be reached, the entire matter shall go before the board.

President W. B. Scott of the Sunset-Central Lines has given to the press statements covering the history of the negotiations and the nature of the road's differences with the employees. A

statement issued by him on the evening of November 13 is in part as follows:

"Beginning with the first part of the current year, the company's officers commenced negotiations with the individual committees, as dates could be arranged, in an effort to dispose of such cases as the committees desired to present. After numerous conferences with the engineers' committee in February, March and April, settlement was reached on all cases presented by them for consideration, and the committee disbanded, apparently satisfied.

"Several conferences were held with the firemen's committee during January, February, March and April, and after a grand officer had been summoned, satisfactory settlement was reached on all grievances submitted by them.

"During June and July conferences were held with the conductors' and brakemen's committees individually and jointly and most of the cases disposed of; there being left unsettled but one case presented by the conductors' committee and fifteen cases presented by the brakemen's committee. A grand officer of the brakemen's organization was called, and after additional conferences in August the number of unsettled cases was reduced to ten; some of which have since been dropped by that organization. The unsettled cases were held in abeyance by the committee, evidently for the purpose of injecting them into the present co-operative movement.

"In the meantime, several engineer members of the firemen's organization were disciplined, and as the provisions of the engineers' agreement prohibited the firemen's organization from handling such cases, these engineers selected an engineer on their own seniority district, usually a chairman of the Brotherhood of Locomotive Firemen, to represent them. Conferences were held and letters were passed covering all of these cases, but as the discipline had been properly applied, the management declined to reinstate such engineers as had been discharged or cancel demerits that had been assessed. The cases were dropped, and in so far as the company's officers were concerned, were considered closed.

"In August the Brotherhood of Locomotive Engineers and the Brotherhood of Locomotive Enginemen and Firemen formed what they termed a Joint Working Board of the Brotherhood of Locomotive Engineers and Brotherhood of Locomotive Firemen and Enginemen, and immediately asked for a conference to discuss a long list of alleged grievances, which included cases that had previously been handled with the firemen's committee, all of the cases of engineer members of the firemen's organization, which had been handled to a conclusion in the manner prescribed by the engineers' agreement, and a number of matters that had not previously been presented. They also presented requests for changes in the engineers' and firemen's agreements, alleging that such changes were made necessary by the formation of the Joint Working Board. Conferences were held in September with the so-called Joint Working Board, and some of the grievances disposed of. Quite a number of the requests were considered unreasonable by the company's officers and no settlement was reached; the company also declining to reopen or reconsider cases that had heretofore been handled to a conclusion by the firemen's organization and by the engineer representatives from the firemen's organization. Notice was served on the company that grand officers would be summoned to the assistance of the committees and negotiations were suspended awaiting their arrival.

"The next heard from the organizations was the letter of September 16, signed by the chairmen of all four organizations, notifying the company of the formation of the co-operative committees, to which a reply was given under date of September 19,

and another letter received September 25 reaffirming the former letter.

"On September 20 the general chairman of the conductors requested a meeting to discuss six alleged grievances, one of which had previously been settled by a former general chairman. On September 26 a supplemental letter was received submitting two additional cases. Owing to high water and other important matters requiring attention, the officers of the company were not able to set a date to discuss these cases immediately, and on October 17 a letter signed by grand officers of all four organizations submitting a list of sixty-seven alleged grievances, and requesting joint conference for the purpose of adjusting them, was received. This list of grievances included all of the unsettled questions with engineers, firemen and yardmen; the cases presented by the conductors which had not been discussed and were not properly on appeal to the grand officers; several cases that had been previously settled with the general chairman of the conductors, and even grievances which had not previously been presented by any of the organizations. It was obvious that the list of alleged grievances had been padded with everything which could be gathered up in order to make it appear that the organizations were very much aggrieved and which were intended to form a basis for the co-operative committees.

"The settlement of the grievances listed, however, seems to have been temporarily lost sight of and the sole aim and purpose of the committees now appears to be to force the company to meet the four organizations jointly so that in the future they will be in a better position to force their will in matters of pay, working conditions, administration of discipline, and rules of operation.

"The correspondence following receipt of this letter up to the time the committee decided to submit the matter to the men has been published, and clearly indicates the company's position with reference to meeting representatives of the four organizations jointly. Existing agreements with each organization, still in effect, clearly and specifically provide method of handling grievances, and by whom they may be presented. Neither party to these agreements can arbitrarily and without consent of the other party change any feature of the agreements, and an attempt to do so (except under methods prescribed in the agreements) by a strike ballot or otherwise, is clearly a breach of agreement.

"The list of alleged grievances presented in the committee's letter of October 17 includes request for reinstatement of eighteen discharged employees, and in some instances demand is made that they be paid for all time lost. Some of these employees have been dismissed for insubordination; others for incompetency and carelessness; one for drinking on duty, and others for responsibility for accidents and violation of the company's rules; all of which offenses are considered of a capital nature and generally throughout the country meet with summary action. Seventeen of the cases involve interpretations of the individual agreements, and may be honest differences of opinion, although the company's officers do not see how the language involved can be susceptible of any different interpretation than that they have placed upon it. Seventeen of the cases are not properly included in the present negotiations, for the reason that they have not been handled in the regular manner, some of them not having been handled at all. Four of the cases are reversals of decisions previously made and accepted by the regularly constituted representatives of the organizations. The balance of the cases are protests against present practice with reference to various reports, examinations, etc., and requests for privileges not heretofore enjoyed; all of which are outside of the various agreements and under no circumstances could be considered grievances.

"With other demands, the committees seek to force back into the service, men who have been properly discharged for cause; to be relieved of making out reports made mandatory by federal laws governing locomotive boiler inspection and safety appliance standards; the discontinuance of the practice of re-

examining train and enginemen on time table and train rules; the discontinuance of re-examination of engineers on machinery; and a protest against methods adopted for the re-examination of train and enginemen on color perception, sight and hearing.

"Rules are frequently altered, revised and amended; locomotive design is constantly changing, and improved appliances are being added, requiring a thorough knowledge on the part of the engineer. The re-examinations, to which objection is made, are not only extremely important because of their relation to the employee himself, but the safety of the general public which is entrusted to the company's care makes it absolutely necessary that not a single precaution be omitted or neglected. The practice is one generally commended and is approved and recommended by the American Railway Association. In fact, such examinations and rule enforcement, as were found lacking on the New Haven road and for which that company was severely criticised in the report of the Interstate Commerce Commission on the Wallingford wreck, have been in effect on the Sunset Lines for many years without opposition, and only at this time are they objected to by the Co-Operative Committees of the four organizations.

"Under present conditions, numerous moves made by the company towards complying with Interstate Commerce Commission and railroad commission rulings, and to effect a greater degree of safety in operation to fulfill the growing demands of the traveling public, have met with the disapproval of the chairmen of the Grievance Committees, and they are making every effort to prevent them.

"Another practice complained of by the organizations, and listed as a grievance, is the method employed by the company in making efficiency tests, a 'Safety First' work inaugurated by these companies in 1902. This consists of checking employees in their observance of danger signals displayed at unexpected places and hours, with the expectation that those who are inclined to disregard danger signals or take unnecessary chances will be detected before, rather than after, an accident. These checks show whether or not flagmen promptly and properly protect their trains as required by the rules. If "Safety First" was always considered, railroad accidents would be few in number and the consequences rarely serious. The Titanic disaster well illustrates the awful results that sometimes follow the failure to observe well established rules of safety. These tests are absolutely essential, and have proven of great benefit not alone to the employees in demonstrating their efficiency, but in affording to the public and employees the protection they have a right to expect from transportation lines, active in the promotion of safety in operation.

"This will be more fully understood and appreciated by the record of the so-called Southern Pacific Lines, whose 9,768 miles of rail lines have during the past five years transported 209,674,539 passengers without a single fatality as the result of a train accident. As a further evidence of these companies' efforts in protecting the safety and welfare of their employees and the traveling public, the records will show that the various lines of the Southern Pacific have constructed, and have in operation, a total of 3,224 miles of track protected by automatic electric block signals, the most modern and effective system of train protection so far developed and successfully operated. The mileage of road thus protected is greater than that of any other railway system in the world.

"In steel car construction, the Southern Pacific was the pioneer in an effort to promote 'Safety First' by developing and constructing in 1906 the first steel passenger coach built in America. Since that time their lines have added annually to their equipment, and now own and operate a large number of all steel passenger cars, with additional similar equipment ordered.

"The grievance committees have charged that discipline is too severe on these lines. As offsetting this the following may be of interest:

"On August 13, 1913, a letter was received from W. S. Stone.

grand chief of the Brotherhood of Locomotive Engineers, advising that the engineers on these lines were complaining of the severe discipline that was being administered. In order to convince Mr. Stone that the complaint was without foundation, the records were gone over for the period of a year prior to that date and a statement prepared showing every engineer who had been dismissed, the cause of his dismissal, and whether or not he had subsequently been reinstated. This statement showed that a total of 58 engineers had been dismissed for proper cause. Notwithstanding this, 22 of them had been reinstated on pleas of leniency and as a result of previous good records. Since that time others of them have been reinstated for the same reasons. Of those remaining out of the service 12 were dismissed for drinking.

It will clearly be seen that if any error has been made in the matter of discipline, it has been in the direction of leniency; yet this fact does not seem to appeal to the representatives of the organizations. When employees are guilty of dischargeable offenses or are so unfortunate as to make serious mistakes, proper discipline demands that they be removed from the service, yet the organizations seek to encourage carelessness and improper conduct by attempting to force the company not only to reinstate, but in some instances reinstate with full pay, employees who have been taken out of the service for proper cause.

"The direct personal interest of the traveling public in the maintenance by railroads of proper discipline of their employees and in the removal of restrictions in contracts between railroads and their employees tending to interfere with the exercise of proper discipline, has been brought home very forcibly by recent accidents to passenger trains resulting in the great loss of life; and traceable more or less directly to the terms of employment which the organizations of trainmen are able to exact. In the recent report of the Interstate Commerce Commission on the accident on the New York, New Haven & Hartford Railroad at North Haven, Conn., Commissioner McChord most emphatically announced that 'Safety First' was the prime duty of railroad management, and that demands of organizations of employees or threatened strikes would afford no excuse for contracts which tended to lessen the employer's right to make and enforce all reasonable rules to promote care and efficiency of trainmen, to punish infractions of such rules, and to secure safety of operation, so far as human care and foresight can do. Responsibility for accidents cannot be shifted from the officials to employees by reference to contracts executed under threat of strikes.

"The position of the officers of the companies in respect to the pending demands of their employees has been in conformity with their duties as they are defined in the report of the Interstate Commerce Commission. If the companies' employees have the same regard for the commission's report and recognize the duties which railway employees as well as railway officials owe to the public, they will not persist in their demands. Certain it is that if the traveling public had a conclusive voice in the determination of the controversy, a due regard for its rights would lead to its approval of the stand taken by the officers of the railroads. The question in a nutshell is, shall the company buy its peace with employees at the price of the safety of the public?"

The company has made public the following analysis of the grievances which are given by the employees as the causes of the strike:

NUMBER OF CASES INCLUDED AS GRIEVANCES BY THE DIFFERENT ORGANIZATIONS.

O. R. C.....	10
B. R. T.....	19
B. L. E.....	20
B. of L. F. & E.....	14
Miscellaneous .....	7
1. Leniency .....	18
2. Interpretations of schedule .....	17
3. Not heretofore presented .....	17
4. Reversal of decisions previously accepted.....	4
5. Discontinuance Hours of Service report at terminals.....	1
6. Discontinuance receipting for engines at terminals.....	1
7. Discontinuance engineers making out fuel tickets.....	1

8. Discontinuance re-examination on train rules and machinery.....	1
9. Protest against method re-examination of men on eye-sight, hearing and color perception .....	1
10. Protest against correspondence .....	1
11. Protest against enginemen handling locomotive indicators.....	1
12. Protest against present method surprise tests.....	1
13. Protest against moving engines under steam without engine tests.....	1
14. Request permission report for duty by telephone.....	1
15. Request boilerheads and side sheets of engines be covered.....	1
16. Request Mikado locomotives be weighed under service conditions.....	1
17. Request ice be furnished at certain terminals.....	1
18. Request fires switch engines be cleaned at noon hours.....	1
19. Request seats on road engines for brakemen.....	1
20. Request for joint working agreement B. L. E. and B. L. F. & E.....	1

In an earlier statement President Scott said in part:

"In all matters of common interest these companies have never in the past, and will not in the future, decline to confer with those organizations. For example: the companies were already negotiating with the engineers and firemen jointly with a view to the making of a joint schedule. Similarly, the conductors and brakemen, whose duties are to a great extent common, are now working under a joint schedule.

"In matters of joint interest, such as the federal hours of service act, equally applicable to all, these companies have never declined to confer jointly with representatives of the four organizations involved.

"The purpose, therefore, of a demand that matters pertaining to the duties of brakemen and conductors shall be determined by joint action with members of a totally distinct and foreign service, and similarly with regard to matters affecting engineers and firemen, is to bring to bear upon these companies the joint and united force of the four organizations to force concessions which these companies, in justice to the public and themselves, and in obedience to the law, ought not and cannot make.

"During the present session of the Congress of the United States, at the suggestion of leading representatives of the four organizations, railway interests of the country acceding thereto, a Board of Mediation and Conciliation was constituted for the express purpose of determining issues of this character, and by wise and conciliatory mediation protect the traveling and shipping public from the inevitable disaster which follows a breach between a railroad company and its employees. These companies cheerfully recognized the fact that they are public service corporations and that their first duty is to obey the law and serve the public interest.

"They, therefore, promptly proposed a reference of the controversy to the board above mentioned, and it is with profound regret that they received notice from the representatives of the four organizations involved that all mediation was declined, and it was with profound astonishment that they received notice that the membership of the four organizations would leave the service of these companies thirty-four minutes after notice that mediation had been declined.

"We state to the public that this is the sole issue involved in this controversy. A list of sixty-seven alleged grievances has been given out to the press. With regard to these, an analysis thereof will disclose:

"(1) That the majority of them, when tested by clear contract provisions, or admittedly long-established practice, are either without merit or have already been disposed of, or are not properly before the grand officers of the respective organizations and the general officers of these companies for consideration.

"(2) That, with two possible exceptions, none of the alleged grievances present matters of common interest to the four organizations, or affect the relations of the four organizations, as a whole, with these companies, which have always been willing (and I have specifically so stated in communications to the representatives of the four organizations involved) to meet representatives of all four organizations in joint conference where grievances involve matters of common interest to all of them. This would apply to the two exceptions above referred to, but would not apply to the remaining sixty-five alleged grievances, where no matter of common interest to the four organizations making the demand for a joint conference is involved.

"(3) That these companies have never declined, and do not

now decline, to proceed in an orderly way, according to the methods specifically provided in existing contracts, and established by usage and practice of years' standing, to dispose of these alleged grievances, meeting the representatives of the organizations involved and making an honest effort to reach a fair adjustment.

"(4) That the demand made, upon the refusal to comply with which this strike has been ordered, is made for the purpose of forcing, through the combined power of four organizations, a compliance with demands which these companies submit are unreasonable and unjust, and, in many instances, inimical to the public interest.

"(5) That putting upon the grievances a construction most favorable to those making the demands, there is no issue, or issues, between any one of the organizations involved and these companies of sufficient gravity to justify the organizations in ignoring the public interest, which must inevitably suffer through the extreme action which they have taken, and in peremptorily declining mediation tendered by the federal board."

## NATIONAL INDUSTRIAL TRAFFIC LEAGUE.

The annual meeting of the National Industrial Traffic League was held at Chicago on November 13 and 14, with President J. M. Belleville of the Pittsburgh Plate Glass Company, in the chair.

A form for the preparation of claims against railways, previously formulated by the Committee on Preparation of Claims, and approved by the Freight Claim Association, was adopted.

In connection with the report of the Committee on Uniform Classification, President Belleville gave an account of a meeting with representatives of the carriers and stated that the latter had already carried out some of the league's suggestions, particularly in giving publicity to the work of the Uniform Classification Committee. He also stated unofficially that the Western Classification Committee now had under consideration a plan which is in accordance with the suggestions of the league for a permanent committee of three or four members to be in continuous session at Chicago, and he hoped that the official and southern committees would do the same thing, and that the three could be combined to form a committee on uniform classification. The president also read a letter from the chairman of the executive committee on Uniform Classification, asking for a joint conference with a committee of the league.

There was a long discussion of the subject of incomplete expense bills, in which many members declared that the trouble was due to carelessness on the part of shippers, while others blamed the carriers. H. C. Barlow, traffic director of the Chicago Association of Commerce, described the work of a joint committee upon this subject with a committee of the American Railway Association, and said that the carriers were co-operating with the shippers in the effort to improve conditions.

The committee on Shippers' evasion of the Interstate Commerce Law offered a resolution that the League put itself on record as opposed to any evasion of the law in any way, and that it should lend its assistance to the railways in all attempts to stop such evasion.

Oscar F. Bell, traffic manager of Crane Company, presented the report of the Committee on Weighing, saying that two conferences had been held with a committee of the American Railway Association and a third was now being arranged for the purpose of discussing ways of carrying out the Interstate Commerce Commission's wishes. He believed substantial progress was being made. There was considerable discussion of the amount of tolerance to be allowed in ascertaining weights and particularly on the question of the removal of refuse in cars. The committee condemned the practice of leaving refuse in cars, and desired that the League should go on record as being willing to co-operate with carriers in this respect, but the members could not agree as to whether it was the duty of the railway or of

the consignee to remove debris from carload shipments under various circumstances, and the question was referred back to the committee.

On the recommendation of the committee on legislation, which made no formal report, it was decided to have a new committee on Needed National Legislation, to be appointed by the new president with the advice and consent of the retiring president.

### POWER TO FIX MINIMUM RATES.

There was an active discussion on a motion that the League recommend that the Interstate Commerce Commission be given power to prescribe minimum rates in order that it might correct discriminations by ordering an increase of an unreasonably low rate instead of only by reductions, often requiring far-reaching readjustments.

F. T. Bentley, traffic manager of the Illinois Steel Company, and H. C. Barlow of the Chicago Association of Commerce were the leading advocates of such a change in the law. Mr. Barlow said that one of the greatest defects in the act, from the standpoint of shippers, carriers and the public, is that the commission has not power to correct a discrimination by removing the cause of the discrimination. Other members thought that the League should not take hasty action on the question and it was decided to defer it to the committee on Needed Legislation with instructions to make a special study and report to the executive committee. If the latter shall be unanimous upon the question it shall have power to recommend the amendment on behalf of the League; if it is not unanimous the subject shall be referred to the membership for a referendum vote.

### PAYMENT FOR TARIFFS RESCINDED.

The committee on Payment for Tariff Publications had prepared a report voicing opposition to the plan of charging for tariffs or classifications, but instead announced that a subcommittee had attended a conference on Thursday with F. A. Leland of the Southwestern Tariff Committee, at which Mr. Leland announced that in response to the vigorous protests of shippers the circular publishing a schedule of prices for tariffs would be cancelled. A letter from Mr. Leland was read, in which he asked in return the co-operation of the shippers in obtaining relief from certain conditions in connection with the distribution of tariffs which the carriers consider onerous. Mr. Leland asked what practical plan can be adopted under which tariffs can be supplied to traffic bureaus, shippers having traffic departments and other bona fide users of tariffs, and at the same time avoid the waste of sending tariffs to those who do not require them, without discrimination. He also pointed out that tariffs are now handled by the Post Office department as third-class mail at eight cents per pound, while periodicals and newspapers are second-class at one cent per pound, and tariffs are also barred from the parcel post. He also referred to the requirements regarding the posting of tariffs at stations, saying that it is unnecessary to post all tariffs applying from each station and an index of all other tariffs, if tariffs are to be furnished to all who want them. Inquiry has shown that at many stations there are no requests to look at tariffs. He requested the League to appoint a small subcommittee to co-operate with the carriers in obtaining some relief in the three respects mentioned. It was decided to refer the matter to the executive committee for proper action, and at the suggestion of President Belleville the tariff committee was asked to give special attention to the simplification of tariffs.

The committee on Car Demurrage and Storage submitted a report of the results of conferences with the committee of the American Railway Association on Relations Between Railways which resulted in an agreement on proposed rules for notification and computing time. The changes reported were approved by the League. This committee also reported on a new code of rules on storage of freight which the American Railway Association committee has submitted to its association for adoption. This report was also approved by Google

J. S. Marvin, traffic manager of the National Association of Automobile Manufacturers, submitted a report of the committee on transportation instrumentalities, as follows:

#### CAR POOLING.

"Your committee recently received advice from the secretary that the executive committee of the League had referred to it for consideration and report to the League, the question of a standard box car and pooling of all freight cars by carriers. It has not been practicable for your committee to hold a meeting, but this matter has been considered by correspondence and otherwise, and it appears:

"First: That American Railway Association car service Rule 1 requires that foreign cars must be promptly returned to their owners, as prescribed by Rules 2, 3 and 4. Per diem Rule 19 provides for a commission to supervise and enforce car service Rules 1, 2, 3 and 4. In a recent report this commission stated that the fair use of open cars can be, and now is, effectively regulated by Rule 19, but that the fair use of box cars cannot be effectively regulated by Rule 19 because the practice of home routing in the case of box cars is an economic waste from which it has developed in practice that there is in effect today a pool of this equipment, without regulation, and in its results unjust, in times of car shortage, to originating lines which have provided their quota of cars, and to the public served by those lines, and during times of car surplus, to distributing lines. It was stated that this pool, in justice to the railroads and the public, should be regulated, to the end that each road, when it needs them, should have the use of its quota of this equipment or its equivalent, and objections to a pool are answered by the fact that existing car service rules have not secured to owning roads the use of their cars, so far as box cars are concerned. It was thought that a pool should lead to the general adoption of a standard box car, and that if standard specifications were to be adopted the cost of building cars would be so reduced as to represent a great saving in capital investment. These ideas were formulated by the commission for its own guidance and as the result of concentrated study of car service under existing conditions. The matter is still having attention but without as yet leading to a definite conclusion. We understand that the American Railway Association is now soliciting mail advices from its members on the question of a standard box car 40 feet long.

"Second: It is not clear that it would be practical for carriers to pool all cars. Open cars, and closed cars of a special character, such as refrigerator, furniture, automobile, carriage, stock cars, etc., could hardly be put on a basis of legal tender equipment with ordinary box cars. Whatever action is taken should be such as to emphasize, and not minimize, the necessity of keeping cars of this kind in the service for which they are intended.

"Third: Even with common box cars there is a wide range of usefulness, comparing the older cars of short length and comparatively small cubic and weight capacity with the cars of more recent construction. This, however, should not offer an insurmountable objection to pooling, inasmuch as there is no rule today that guarantees absolutely to any railroad the use of its own cars.

"Fourth: Primarily, freight cars are the property of railroads, and the formulating of rules for their use and interchange rests with the carriers. Your committee has been unable to reach a conclusion that is unanimous on what action, if any, the league can or should take in this matter. But periods of car shortage are of such serious import to the shipping public that in view of the feeling on the part of the public, which is shared by railroad officials, that a change in existing rules could be made to the great advantage of shippers and which would result in greater economy in operation for the railroads, and that a pool of common box cars seems to offer the necessary relief, the opinion prevails in your committee that the League should commend the investigation of this matter by the railroads and that from the

shippers' point of view it is a matter of such importance as to warrant special action by carriers in order that measures of relief may be promptly ascertained."

The report was approved and the subject was re-referred to the committee with instructions to keep in touch with the American Railway Association.

The committee on Demurrage and Storage Charges upon Export Traffic made no formal report, but declared that before any arbitrary adjustment of storage and demurrage rules can be made carriers will have to make as a part of their regulations, particularly as to freight consigned for export or handled on through bills of lading, a guarantee of time from shipping point to the port of export. The subject was re-referred to the committee for continued study.

The committee on demurrage supervisors outlined the plan by which the American Railway Association Committee on Relations between Railways will appoint demurrage supervisors in various districts to secure uniform administration of demurrage rules, and said in conclusion: "It is hoped that through the medium of these demurrage supervisors closer and more amicable relations will result between carrier and shipper and that differences which are largely minor will be adjusted with promptness."

The committee on Tariffs recommended that the letters A and R in a circle be uniformly adopted by all carriers to indicate advances and reductions, respectively, in tariffs, and that the use of letters N, C, E and X be uniformly adopted to indicate other changes, such as additions, changes, eliminations and cancellations; the uniformity to be gradually effected with the issues of new tariffs and classifications.

The report was approved and the subject will be taken up with the Interstate Commerce Commission.

The committee on storage charges upon Domestic Less-Than-Carload Freight reported that there is a wide variation in the charges and practices of the carriers in the matter of storage of freight; at some points 72 hours free time is granted in the case of less-than-carload shipments, and property if not then removed is sent to public warehouse; at other points after the expiration of the usual free time (48 hours) the property is sent to public warehouse; at many other points where there are located public warehouses the carrier furnishes warehouse facilities and charges accordingly for such services. The committee has been unable to present, by reason of the widely divergent views expressed and the different conditions found, any concrete rule for consideration. It was therefore decided to circularize the members for opinions as to a uniform storage charge.

#### GENERAL ADVANCE IN RATES.

After a protracted discussion in executive session on Friday the League decided not to place itself on record as either in favor of or opposed to the proposed general advance in freight rates in Official Classification territory, but adopted a resolution that the League "is in sympathy with the plan of the Interstate Commerce Commission to investigate the question fully," and that the subject be referred to the members "for such action as their interests may justify and require."

A motion was made that the League recommend the reappointment of Commissioner Clements to the Interstate Commerce Commission when his term expires. This was not carried for the reason that it is contrary to the policy of the League to endorse candidates for public office, but a large number of those present declared themselves in favor of his reappointment.

Officers were elected as follows: President, H. G. Wilson, transportation commissioner of the Commercial Club of Kansas City; vice-president, Joseph Keavy, commissioner freight and traffic division, Indianapolis Chamber of Commerce; secretary-treasurer, Oscar F. Bell, traffic manager, Crane Company, Chicago.

The annual banquet of the league was held on Thursday evening at the Hotel LaSalle. George T. Bell, commissioner of the traffic bureau of the Sioux City Commercial Club, delivered an

address on "Traffic Bureaus," and Harry A. Wheeler, president of the Chamber of Commerce of the United States, gave an address on the relations of railways, industrial concerns and the banks to public regulation.

### NATIONAL CIVIC FEDERATION TO INVESTIGATE SOCIAL PROGRESS.

The National Civic Federation, through its Industrial Economics Department, has decided to undertake a national survey in these three respects:

(1) The progress made by this country in the last several decades, socially and industrially.

(2) The ground for the socialistic demand that private ownership in the means of production and distribution of wealth be abolished.

(3) The differences in the fundamental aims and methods of the labor movements, as conducted by the trade unions, the socialist parties, and the Industrial Workers of the World.

The work in detail will be done by a corps of trained investigators, under the direction of a representative advisory council, the sympathy and aid of which can be invoked in this important work. The council will be composed of leaders in the world of labor, of agriculture and manufacturing; representatives of the press, the church, the college, finance, law and medicine, as well as officials of national organizations familiar with many of the specific problems covered by the inquiry. The investigation will be in effect "a national inventory of social assets and liabilities," and will endeavor to show how far the general movement of our republic has been toward progress, and what steps can be taken to establish it firmly on the way to further progress. It is believed that there could be no better time than the present to undertake such work.

A general announcement of the survey has been issued by a committee on plan and scope, of which Dr. Talcott Williams is chairman. The announcement states that it is clear that the twentieth century is to be devoted to the settlement of economic issues, just as the close of the eighteenth and the beginning of the nineteenth century were devoted to the solution of political issues, and that the present social and economic situation brought about by the creation of great corporations, changes in industrial development, large immigration, the massing of population at centers of industry, changes in the conditions of life in large cities, bringing profound shiftings in the distribution of wealth, and the relations between employer and employed, is disturbing to the public conscience of the republic.

"It is sufficiently serious," says the announcement, "in the opinion of many who have the welfare of this nation at heart, to make necessary an impartial, dispassionate and scientific investigation by experts into the economic changes of the last 30 years with a view to ascertaining both our national successes and failures. The course of the new economic era has been sufficient to render it wise to take an account of our national movement and condition, exactly as account of stock is periodically taken in business. The proposed investigation, in order to encompass the facts at issue, good or bad, should include, broadly:

"The factors concerned in the production of wealth.

"The methods by which the wealth produced is distributed among the several factors engaged in production.

"The effect on industrial, social and individual progress."

Among the points mentioned which are to be investigated, are the concentration of wealth, the condition of the farmer, the effect of social legislation, the state of political and business ethics, etc. One of the questions which the investigation will seek to answer is: "Does the popular concept today of the relations to the public of industrial, railway and municipal utility corporations spell progress, as compared with the accepted view twenty years ago? Or is regulation a failure and should the

state take the place of private capital? What, if anything, has been gained in the last decade through the demand of the people for publicity in the business methods of banks, insurance companies, trust companies and other private corporations?" This naturally includes an inquiry into the subject of nationalization of railways, and it is probable a commission will be sent abroad to study the results of government management in foreign countries.

### SAFETY FIRST ON THE WESTERN MARYLAND.

The Western Maryland had its first general "safety-first" meeting at Hagerstown, October 30, and about 300 employees were present. The company's Safety Engineer has sent to every employee of the road cards, properly inscribed, on which unsafe conditions observed by the employee may be made known to the proper officer.

The Hagerstown meeting was addressed by W. P. Borland, assistant chief inspector of safety appliances for the Interstate Commerce Commission, who spoke, in part, as follows:

The most notable and admirable characteristic of the present era of industrial development is the effort to conserve human life. This effort finds concrete expression in safety legislation, both state and national, and in organized efforts to promote safety in the operation of our mining, manufacturing and transportation industries. We all know that it is a fundamental rule of train operation to take the safe side in case of doubt; and we also know that it is not well with the man who causes delay to traffic by doubting too much. He can acquire a better reputation as a railroad man by taking a chance now and then and making a good run with his train. Rules innumerable have been formulated and promulgated to secure safety, but these rules have been violated time after time with the full knowledge of operating officers whose duty it was to enforce them.

These conditions furnish a sufficient reason for the safety first movement, and it is quite obvious that the conditions must be changed if the movement is to become a success. "Safety-first" means the establishment of an entirely different ideal from that which has heretofore existed in the minds of railroad men. It means more cordial and intimate relations between operating officers and employees.

The fundamental principles are well understood by railroad men of experience, and it does not require an elaborate system of rules to impress them upon their minds; yet there is not a train service man of any considerable experience who can truthfully say that he has never deliberately disobeyed these principles.

"Safety-first" means simply a consistent, proper and efficient performance of our duties. . . . In our investigations of train accidents we have found numerous cases where special rules have been promulgated, establishing conflicting standards for the control of like situations, and we have found many cases where certain operating rules have been permitted to fall into complete disuse, only to be revived for disciplinary purposes in case of accident. In some cases operating rules have, by common consent, been held to have no application to particular cases until they were practically forgotten, and then have been resurrected and advanced as justification for inflicting discipline upon employees because of an accident which occurred on account of their non-observance. One case of this kind I will mention, because it occurred on a "safety-first" railroad.

[Mr. Borland here recounted the circumstances of the collision of passenger trains at Terre Haute, January 8 last, reported in the *Railway Age Gazette* of May 9.]

It was thoroughly established that nobody had been expected to protect the rear end of a train by a flag when it was standing where this train was standing, but the conductor

of the standing train was censured for not protecting by flag, as required by rule 99. It is discipline of this kind that creates resentment in the minds of employees and destroys their confidence in the justice of their officials, which confidence must be the basis of that co-operation and harmony essential to efficient and safe railroad operations.

The word discipline has a sinister meaning for most railroad men. There are several definitions to this word. One is "instruction and government, comprehending the communication of knowledge and the regulation of practice; the training to act in accordance with rules." Another definition is "correction, chastisement, punishment, inflicted by way of correction and training; instruction by means of misfortune, suffering and the like." Railroad employees have had ample experience with the latter kind, but they have had altogether too little of the former, which fact will explain their repugnance to the term.

Discipline is absolutely necessary to the success of any organization where individuals must work together for a common end. It is especially necessary in railroad service, where the safety of human life is at all times dependent upon the proper action of some individual. But discipline does not mean simply tying a can to a man whenever he does something wrong. It means educating and instructing him to act in accordance with proper rules, so that he will learn to do the right thing as a matter of habit. It means the creation in his mind of a feeling of confidence in the justice of the governing body.

Of course it cannot be expected that ideal discipline will burst forth upon us full blown, especially in view of the improper methods that have long generally prevailed throughout the country, but this safety first movement is pretty good evidence that there has been an awakening.

**TRAIN ACCIDENTS IN OCTOBER.<sup>1</sup>**

Following is a list of the most notable train accidents that occurred on railways of the United States in the month of October, 1913:

*Collisions.*

Date.	Road.	Place.	Kind of Accident.	Kind of Train.	Kil'd.	Inj'd.
2.	St. Louis S. W.	Stephens.	bc	F. & F.	4	3
2.	Yazoo & M. V.	Hollywood.	bc	P. & F.	1	1
3.	N. Y. Chi. & St. L.	Fairview, Pa.	bc	F. & F.	2	1
6.	Balt. & O.	Summerfield.	rc	P. & F.	2	2
*5.	Great Northern	Ulm, Mont.	rc	F. & F.	2	0
9.	Southern	Grand Junc.	rc.	P. & F.	1	18
†10.	N. Y. N. H. & H.	Westfield, Conn.	bc.	P. & P.	1	10
20.	Penn.	Portville, N. Y.	xc.	F. & F.	2	3
22.	Seaboard A. L.	Gaston, S. C.	bc.	P. & F.	0	15

*Deraillments.*

Date.	Road.	Place.	Cause of Derailm't.	Kind of Train.	Kil'd.	Inj'd.
2.	Penn.	Garland, Pa.	b. rail	P.	0	7
8.	Chi. Mil. & St. P.	Ingomar.	beam	P.	0	20
10.	C. C. C. & St. L.	Columbus.	acc. obst.	P.	2	0
12.	Atlantic C. L.	Live Oak.	exc. speed	F.	1	3
†13.	Mobile & O.	State Line.	unx.	P.	17	90
19.	Atlantic C. L.	Green Pond.	malice.	P.	1	4
19.	C. C. C. & St. L.	Tiffin.	.....	P.	0	28
19.	Chi. & Alt.	Alton, Ill.	d. track	P.	0	15
27.	Southern	Easley.	.....	P.	1	3
31.	Texas & P.	Alexandria.	malice.	P.	0	4

The trains in collision near Stephens, Ark., on the 2d, were a southbound freight train and a northbound train consisting of an engine and a pile-driver car. Both engines and 12 cars were badly damaged. Three trainmen and one laborer were killed

and three trainmen were injured. The cause of the collision was the neglect of the freight to wait at Stephens, as ordered.

The trains in collision at Hollywood, Miss., on the 2d, were southbound passenger No. 15 and the northbound freight. The passenger train ran over a misplaced switch and into the head of the freight, which was standing on a sidetrack. The fireman of the passenger train was killed and the engineman injured. Many passengers were badly shaken up and bruised. Both engines and four cars of lumber were badly damaged.

The trains in collision at Fairview, Pa., on the night of the 3d, were through freights. Two trainmen were killed and one injured. The eastbound train had passed a signal set against it.

In the collision near Ulm, Mont., on the 5th, a train consisting of an engine and one car ran into the rear of a preceding freight, wrecking the caboose and two empty stock cars, which took fire and were burnt up. The conductor and one brakeman of the freight were killed and their bodies badly burnt. There was a blinding snowstorm at the time. The freight was moving about 6 miles an hour, and was not properly protected.

The trains in collision at Summerfield, Ill., on the 6th, were westbound passenger No. 3 and a westbound freight. There was some fog at the time. The freight was entering a sidetrack; it was run into at the rear by the passenger and the passenger engine was overturned. The engineman of the passenger and a trespasser stealing a ride were killed and two other trespassers were injured. The cause of the collision was neglect of flagging on the part of the freight and excessive speed, under a permissive signal, on the part of the passenger train.

The collision on the Southern Railway at Grand Junction, Tenn., on the night of the 9th, was due to a misplaced switch. The eastbound "Memphis Special" running at full speed crashed into a freight train standing on a sidetrack. The engineman was killed and 14 passengers, one employee and three postal clerks were injured; nearly all of the injuries were slight.

The trains in collision near Westfield, Conn., on the evening of the 10th, were an eastbound passenger consisting of two cars and a locomotive, running backward, and a westbound passenger train consisting of one electric car. This was a butting collision on a straight line, the electric cars using this part of the line regularly. The electric car was wrecked and one passenger was killed and ten were injured. The electric car had passed its regular meeting point. The motorman was indicted on a charge of manslaughter.

The collision at Portville, N. Y., on the 20th, was between a light engine and train No. 95, both northbound. It was at the passing siding. Two student brakemen were killed, and one engineman, one fireman and one brakeman were injured. The light engine and train No. 95 had been on the siding waiting for train No. 58 to pass. After this train had passed, the light engine was given orders to run ahead of train No. 95 and backed out the south end of the siding to the main track; then, while running north at a speed of about 15 miles an hour, it struck the tender of the engine of train No. 95 at the north switch of the siding, due to the engine of the latter train fouling the main track.

The trains in collision near Gaston, S. C., on the 22d, were northbound passenger No. 20 and a southbound freight, and seven passengers and eight trainmen were injured. The collision was due to misreading of orders by the men in charge of the freight.

The train derailed at Garland, Pa., on the evening of the 2d, was westbound passenger No. 41. The cause of the derailment was a broken rail, and all of the cars went into the ditch and lodged against the side of a cut. Five passengers, one employee and one other person were injured.

The train derailed at Ingomar, Mont., on the 8th, was the eastbound Columbian express. The train was traveling at regular speed and four cars were ditched. The cause of the derailment was a broken brake beam on an express car. Twenty passengers were injured.

The train derailed at Columbus, Ohio, on the 10th, was west-

<sup>1</sup>Abbreviations and marks used in Accident List:  
 rc, Rear collision—bc, Butting collision—xc, Other collisions—b, Broken—d, Defective—unf, Unforeseen obstruction—unx, Unexplained—derail, Open derailing switch—ms, Misplaced switch—acc. obst., Accidental obstruction—malice, Malicious obstruction of track, etc.—boiler, Explosion of locomotive on road—fire, Cars burned while running—P. or Pass., Passenger train—F. or Ft., Freight train (including empty engines, work trains, etc.)—Asterisk, Wreck wholly or partly destroyed by fire—Dagger, One or more passengers killed.



bound passenger No. 41. The engine was overturned and the engineman and fireman were killed. The train while running at moderate speed struck a hand-car.

The train derailed near Live Oak, Fla., on the 12th, consisted of a locomotive and a caboose. The engineman was killed and three other trainmen were injured. It is believed that the derailment was due to excessive speed.

The train derailed near State Line, Miss., on the 13th, was a westbound passenger train, the second section of No. 4, carrying soldiers. Seventeen soldiers were killed and 90 were injured. An officer writes that the cause of the derailment was not discovered. The track was found in good condition and the train was running at moderate speed.

The train derailed near Green Pond, N. C., on the evening of the 19th, was northbound passenger No. 86, and the locomotive was overturned. The fireman was killed and the engineman and three other persons were injured. The cause of the derailment was due to a partly open switch. It is believed that it had been maliciously tampered with.

The train derailed at Tiffin, Ohio, on the 19th, was a northbound passenger, and the engine, baggage car and two coaches fell down a bank. Twenty-eight passengers were injured, three of them seriously.

The train derailed near Alton, Ill., on the morning of the 19th, was a southbound passenger, and three passenger cars were ditched. Fifteen passengers were injured, two of them seriously. The derailment is believed to have been due to irregular track.

The train derailed near Easley, Ga., on the 27th, was passenger No. 11 and the engine and all of the cars, except one, were overturned. The engineman was killed and the fireman, baggageman and express messenger were injured.

The train derailed on the night of the 31st, near Alexandria, La., was westbound passenger No. 53, and the baggage car and two passenger cars were overturned. Five passengers were injured, none very seriously. The cause was an unfastened switch which had been tampered with by some person unknown.

*Electric Roads.*—In a collision on an electric road near Dallas, Tex., on the 14th of October, four persons were killed and twenty injured. A freight car broke away from a train ascending a grade and then ran back down hill into the head of a passenger car.

*Canada.*—In a collision between a freight train and a work train on the Canadian Pacific near Weyland, Ont., on the 21st, five employees were killed and seven injured. It is said that the work train had entered the main line between the first and second sections of the freight, when, according to the order issued by the despatcher to the conductor and engineman, it should have waited on the sidetrack until both sections of the freight had passed.

**FLOOD DAMAGE IN ARGENTINA.**—The recent flood rains, although good for the crops, have somewhat disorganized the services on some of the Argentine railways, the Buenos Ayres Great Southern Railway probably suffering the most. In spite of the damage done, the engineering staff of the line very creditably effected temporary repairs to the washouts, so that traffic was resumed with but little delay. All the long distance day and night trains have now resumed their usual itinerary from the terminal station, Plaza Constitucion. The Central Argentine Railway still continues to show great expansion in its traffic, recording substantial increases each week. Passenger traffic has recently been particularly heavy owing to the excursions connected with the various fiestas, races and shows, held at many points on the line. For example, a record crowd visited the Argentine Derby at the Palermo race course, and on the Tigre branch over 5,000 passengers were transported to the Spanish "Romerias" at Saavedra. The traffic to the Argentine "Henley" also helped to swell the crowds, but in spite of the great rush the traffic department had no difficulty in carrying out the arrangements in a manner satisfactory to all concerned.

## NEW STEEL JOURNAL BOX.

McCord & Company, Chicago, have just placed on the market the new combination pressed steel and cast steel journal box shown in the illustration. The pressed steel cellar and the cast steel top are made integral without the use of rivets or any other attachments that could be loosened by vibration in service. This



Combination Pressed Steel and Cast Steel Journal Box.

box is the result of many years of experience in journal box manufacture by this company and it is believed by the makers that it will meet all the demands of steel journal box requirements.

## TALK WITH PASSENGERS, NOT AT THEM.

An award of \$25 for the best essay submitted by the agents of the Baltimore & Ohio on "How a Ticket Agent Should Handle an Undecided Inquiring Caller" has been awarded to Elias Bernstein, ticket agent of the Staten Island Railroad, at Pleasant Plains, Staten Island, New York City. This is the New York division of the B. & O. Numerous other papers were voted honorable mention and will be placed in the hands of agents along with the prize essay. Mr. Bernstein says, in part:

"Whether it be on the road with the merchandise or behind the ticket counter, the salesman must have at his command a thorough knowledge of his business and an understanding of human nature.

"It is a great art to handle a man in such a way as to win both his trade and his friendship. A living man is the most complex piece of machinery in the world. Compared to him, a locomotive is a play toy. The slightest blunder may cause him to work badly or to break down; yet there are no printed directions attached to him. All we can do is to watch his eyes and do our best.

"Now let us suppose a case of an undecided caller. He wants to know what advantage our road has over another which also runs to his destination. Certain golden rules must be closely adhered to. The first greeting from the agent must be a sunny smile. He must listen attentively and study the brand of information desired.

"Since first impressions are very lasting the company's servant must have at his fingers' tips the facts and figures. It must also be kept in mind that it is easier to win a man through his eyes than his ears. Diagrams and maps are very helpful and speak for themselves. You can never win a man by talking at him; you must talk with him."

# Maintenance of Way Section.

THE first severe storm and cold snap each fall finds a number of roads unprepared for winter, and because of its uncommonly early arrival the effect of the storm of last week was more pronounced than usual. In spite of the very generally recognized detrimental effects of delaying the renewal of ties, heavy surfacing and other work which should properly be done during the summer months, many roads continue to postpone much of this work until the last minute. The primary difficulty lies in most instances with the higher officers, who withhold material and labor in the spring, but it is not entirely confined to them. The supervisor, in distributing his material and labor, also has an important influence. By a careful and intelligent distribution he can do much to facilitate the work throughout the season and thereby decrease the amount remaining to be done in the fall. By studying the cost of the work done at this season of the year, the savings made by doing things at the proper time should be made evident. The past few weeks have been favorable for track work and where proper advantage has been taken of the conditions, the track will go into the winter in excellent shape. At the same time, this favorable weather has been utilized in many instances to put in ties, to do heavy surfacing, etc. While there is a gradual improvement throughout the country in this matter, it is not as general as it should be, and there is still much to be desired. The time to begin to avoid fall work is in the spring, and the results of needless delays can be best observed at this season.

EVERY division engineer and supervisor has occasion to require the services of a work train frequently. Many have one or more under their control all the time. The proper handling of these trains to secure the greatest benefits is, therefore, a matter of general interest. Maintenance men many times complain that they are unable to secure work trains from the operating department as frequently as they desire. At the same time, it is not uncommon for trains to be called out to do work which can be handled more economically by other means, especially if delays to traffic are considered. The relative economy of regular, as compared with occasional employment of work trains depends primarily upon the amount of work to be done. When a train is secured it must be supplied with sufficient, but not too many men, and must be under the direction of an experienced foreman or work train conductor. The job must be planned carefully so that no time will be lost, for the overhead charges are high. These and many other important considerations enter into the economical handling of work trains. To secure a full discussion of this important subject we announce a contest on the "Proper Handling of Work Trains," in which we hope to receive a number of contributions describing the ways in which work trains are, or should be handled and manned, their uses and their abuses, their relative economy for various things and other considerations to which the supervisor should give weight in this connection. We will pay \$25 and \$15 for the two best papers received, and our regular space rates for all other papers accepted and published. All contributions should be sent to the Engineering Editor, *Railway Age Gazette*, 608 S. Dearborn street, Chicago, by December 27, in order to be considered by the judges of this contest.

ON May 12, 1913, an Oregon-Washington Railroad & Navigation Company train was derailed near Lakeview, Wash.,

while running over the tracks of the Northern Pacific, the result being the death of four, and the injury of seven persons. As this derailment was directly attributable to defective maintenance practice, we will review the details as reported by the chief inspector of safety appliances to the Interstate Commerce Commission. At the time of the accident the section men were engaged in the renewal of ties, and an examination of the track showed that within a distance of 16 rail lengths 46 ties had been placed. Very few of these ties had been spiked, the number unspiked under adjoining rails being respectively, 4, 7, 4, 7, 2, etc. Of the 7 ties under one rail 5 out of 6 successive ties were unspiked, while on another rail 4 out of 5 successive ties were unspiked. The conclusion was drawn by the inspector that the section men had started at one end removing the spikes and ballast from the ties to be renewed, and had then started in again at the same end taking out the old ties and putting in new ones, intending to complete the ballasting and spiking of the new ties after all of them had been placed in the track. When the engine hit this track at an estimated speed of 60 miles an hour, which was allowable under the rules on this division, it began to rock and placed sufficient outward pressure upon the rail to push it out and turn it over, derailling the train. The rules on this road, as on most roads, leave the matter of flagging to the judgment of the individual section foremen, and the foreman in this instance was an experienced man who had been in charge of section and extra gangs for 29 years. The serious results arising from error in judgment on his part indicate the importance of proper instruction of the foremen by the roadmaster regarding the necessity for proper flagging as well as for proper handling of track work in order not to introduce any unnecessary elements of danger, as was done in this case by weakening the track to the extent that was done.

A SUBJECT which is now being forced upon the serious attention of railway engineers in a number of states is that of clearance. There has been in the past some hesitancy to discuss this matter freely, but it would seem that the time has come when the railways can unite to eliminate clearances which are now generally recognized as not conforming to good railway practice. Such action would do much to prevent unfair legislation in this direction. The greater number of obstructions that now exist within recognized clearance limits were placed there years ago when construction standards were far below their present level. Such obstructions are gradually being removed as the facilities are being rebuilt and improved, but in a few instances new work is being put in without reference to proper clearance, where the only objection to observing the recognized standards is that the cost would be slightly increased. Many roads have spent large sums of money to increase their clearances, but others have given the subject very little serious consideration and are not only allowing present obstructions to remain, but are actually building new structures or allowing private industries to build them, which interfere with standard clearance. The obvious result of such action, as shown by previous experience, is legislation intended to enforce standard limits, but usually more radical than conditions require, thereby imposing unnecessary restrictions upon the roads. Several states, including California and Minnesota, have already passed clearance laws, and numerous bills have been presented in other states. As an example of the unfair provisions which may be incorporated in such laws, the standard clearance diagram which is fixed by the Minnesota statute is rectangular in shape. If this law is enforced it will remove all

cattle guards, many through and half-through plate girder structures, through truss portal bracing, etc. If other states follow the lead of those that now specify railway clearance, the standards will vary widely and the railways will be forced to appeal for federal legislation to harmonize the conflicting requirements, when the entire subject might have been settled and considerable expense and annoyance avoided if the railways had but agreed among themselves and decided to put into force the clearance diagrams that are now found in the proceedings of their associations.

#### BRIDGE INSPECTION METHODS.

THE importance of frequent and thorough inspections of all bridges carrying trains is fully appreciated by railway officers in charge of their maintenance and few persons outside of railway service realize the amount of attention these structures receive. It is largely for this reason that the methods and frequency of inspection on different roads vary according to the ideas of those in charge regarding the best means of insuring the proper maintenance of structures and the prompt discovery of defects. To afford an opportunity to compare these methods on the leading roads, the practice of several representative roads is presented in another column.

The practice of requiring the section forces to inspect structures casually as they pass over them daily and to report immediately any evident defects, is common to all roads. Likewise, it is customary for a monthly inspection of all bridges to be made by the local division forces. On some roads the master carpenter is expected to do this work in connection with his other routine duties. On other roads one or more inspectors are assigned to each master carpenter and spend their entire time on inspection work. Where the number of structures is large enough, or where their condition requires careful attention, it would seem that the latter method would insure a closer and more careful inspection, as these men become more experienced in this line of work and possess a more accurate knowledge of the actual condition of the individual structures on the division. Whether the inspection is made by the master carpenter or the division inspector, it is frequently difficult to secure the careful inspection necessary and the work may become more or less mechanical in nature. With the result that defects not readily observed, but nevertheless serious, may be allowed to develop.

To secure a good check on the thoroughness of the division inspection, the Lehigh Valley and Pennsylvania employ inspectors who examine all structures on the road at stated intervals. These men report directly to the general officers, and work independently of the division forces. By comparing the reports of the general inspector with those of the division inspectors, lax inspection can be readily detected and the general efficiency of all inspections can be raised.

An annual inspection by the chief engineer, bridge engineer or their immediate assistants is also common to most roads. The thoroughness of this inspection, however, varies from the casual inspection of all structures to the detailed inspection of those structures which it is thought are in most need of immediate attention. In the matter of forms, some roads enumerate in detail the points to be considered by the inspector, and he reports on each one of these. On some other roads, as the Lehigh Valley, the form is simple, and the inspector reports the condition of the various portions of the structure in his own words. Each method has its advantages.

We have secured descriptions of those in use on the Lehigh Valley, the Grand Trunk, the New York Central & Hudson River, the Missouri Pacific, the Southern Pacific, the Pennsylvania Railroad and the Chicago, Burlington & Quincy.

## Letters to the Editor.

### THE TECHNICAL GRADUATE HERE AND ABROAD.

SPOKANE, Wash., November 11, 1913.

TO THE EDITOR OF THE RAILWAY AGE GAZETTE:

In one of the northwestern states an engineering party were engaged in location work for a new railroad, and a bright appearing young chap, of Greek or Latin origin, was given an important position on account of his fine technical education. His inability to handle the English language, however, worked against him, and he was soon succeeded by a young American. He was offered a minor position of "stake artist" or chainman, but this he indignantly refused, and left camp immediately and abruptly.

His opinion of the American engineer, in general, as given in the letter which he wrote to the chief after his departure, is in true Japanese schoolboy fashion, and shows that, so far as English composition is concerned, H. Togo has "nothing on him."

Sir:—I write you this lines not to ask you for job, because man of such superstition like you do not admit of the state of anybody else except himself and his religious peoples. I only want to give you an idea about me and old country students and schools, compared with the education and school of this country. When I tried 5th degree (elementary schools) I choised technical schools—and my first work that had in wass to become handy to use levels, transit, bars meters, plain tabels, gradienter, studia, ect., ect., ect., with all requirements of mathematic work very simple; that time I was masster of that. At this country man carry a tube of that sort upon his scholder is classified and called ENGINEER—At old country work of that kind can be done by any man of good sense, only neede to have manual training in handling cogarithm tabels and trigonometric function tabels—I know to have curves, crossovers, spirals, ellipse, cycloid and so on, ect., from 10 years ago with the use of pur Geometry—and arithmetic. After 2 years of that kind of practise then in some school I toocked coarse of phisicks and mathematics, masonry and structures, very hard work, and thus work was done before I entered the University where I have the large complicate experimental work; and I have had 2 years in Civil Industrial Engineering, and I can prove that either a professor of any university in this country don't know of his subject much as a poor student of old country universitys know to have. What I want to say—that men are titled here Engineer are compared with the fallows that start the work in Geometry and get handy in instruments. The meccanical and Electrical Engineers are as good meccanics of old country. Why I am in this conditions is from misfortunes. And because I been work between gelous peoples where they cut me chance to go ahead, and why never I had acquaintance and pol of somebody else like any one else have and why never I had to say principle man for job. Other ways the instinctive odii of races do not permit the amalgamation with some kinds of peoples. IF I WAS of different origin perhaps might I could have now good position. But if you, honorable chief, wass a gentlemen of my blood, perhaps instead to give another man command of that work you would to give to me because of some of your same blood and it is why your peoples keep gone and rappresent on jobs. You could say me in that condition why don't gone back at the old country. I must answer that we gon make this our country more better than you do. If you mind that our immigration in this land begun 20 yrs. ago and examining and comparing you find to have the progress, development better than any colony.

You told me that I can to obtain job as Chainman, steak man. In regard of that I can tell you that not one of your people can to determine exactly the degree of latitude and longitude in which your famous line gon be built. The people chaining, steaking of that kind of experience in old country belong to a common class. Don't you think me a man of that kind, please. *The suit close do not make no man!* Here you figure that way, but it is false! What I know of English is knowgh to me for my work to judge a man you must practice man first.

Keep you onyour career with all bunch and remember that when some old country man look for job is not master leveler, transit, ect., but is man of professional training, and good to. And you insted to send this man chain, steak, ect., you send your engineers chain, steak, ect., with him. Your country is infested of many civil engineers like Salvation Army do; but I could make contest they don't yet understand what is to know for civil engineer. But man with brass pipe, high top shoes and flat hat he is Civil Engineer in America. The bigottism the preachers that I lived at towns of France and Italy I find here between your peoples and all ignorants.

Truly yours,

F. LEONARD.

# METHODS FOR THE INSPECTION OF BRIDGES.

Description of the Systems in Use on Seven Representative Roads for the Periodic Examination of All Structures.

## ON THE LEHIGH VALLEY.

By F. E. SCHALL,  
Bridge Engineer, Lehigh Valley.

The Lehigh Valley is divided into six operating divisions, with a division engineer, a supervisor of bridges and buildings, and a bridge inspector on each division, except the Buffalo division, where, on account of its large mileage and number of bridges, two bridge inspectors are employed. The division bridge inspectors go over their territory constantly inspecting the structures. The supervisor of bridges and buildings and the division engineer are also required to make inspections of structures at certain periods, and besides this, the supervisors of track and the track foremen are required to inspect the structures on their respective territories. In addition, a general bridge inspector is employed to inspect structures, following up the division bridge inspectors' reports on certain defects and making a general fall bridge inspection on the whole system.

The mileage of main line and main track of branch lines on each division is as follows:

New York division .....	22.08 miles
New Jersey & Lehigh division .....	227.20 miles
Wyoming division .....	310.59 miles
Buffalo division .....	331.09 miles
Mahanoy & Hazleton division .....	201.87 miles
Auburn division .....	302.30 miles

Under the instructions governing the inspection of bridges on this railroad, the bridge inspector, reporting to the division engineer, is to make a careful inspection of all arch culverts, bridges, trestles and highway bridges on his division at least every two months, and special additional inspections of such of the structures as under load show undue vibrations or other irregularities, defective members, settlement or other defects requiring more frequent inspection. The bridge inspector is to observe the action under moving loads of all old bridges and trestles, and on bridges and trestles that show slight defects, to ascertain whether there is any excessive vertical deflection or side motion in the bridge. He is to note the track to discover any undue deflection in the surface of the track on any part of the bridge or trestle to ascertain the cause of such irregularity, and to make a concise report on the same. He is also to observe the action of all other arch culverts, bridges, trestles and highway bridges under moving load as often as opportunity offers.

The bridge inspector reports on each bridge separately on the day of inspection on a specific blank, divided into three parts, the upper space for the entering of conditions or any defects found, in the inspector's own language, the middle space for the entering of data as to the work to be done to maintain the structures in good condition, and the lower space for noting any work that must be done to keep the structure safe or any action taken by the inspector pending the regular repairs or attention by the bridge forces. In cases requiring prompt action, a telegraphic report is made to the division superintendent, the division engineer and the supervisor of bridges and buildings, followed by the regular daily report. The division superintendent makes a telegraphic report to the engineer, maintenance of way, and to the bridge engineer of any urgent case, describing the conditions which may have been found with a statement of such action as may have been taken. The bridge inspector shall, if conditions require, stay at the bridge to protect the trains and traffic until he is relieved.

In addition to the work of the bridge inspector, the supervisor of bridges and buildings is to make an inspection of all culverts, bridges, trestles and highway bridges on his territory every six months, making a report on the condition

of the structures to the division engineer. The foreman carpenter while at work at or near such structures is to inspect them as opportunity offers and report conditions found to the supervisor of bridges and buildings. The track supervisor and track foremen are also charged with the duty of inspecting all culverts, bridges, trestles and highway bridges on their respective territories, noting particularly the surface and tamping of tracks on bridges and approaches, the spiking of tracks and guard rails, any settlement causing shifting of tracks, rubbish in creek channels, undermining of foundations, cracking of walls, etc., the supervisor of track reporting conditions to the division engineer.

The track foremen are especially charged to inspect all structures each month and oftener if necessary, especially after heavy storms, rains, etc., to note any defects in the masonry of culverts, bridges, highway bridges and the supports of trestles, removing promptly any rubbish collecting around openings; to notice any undermining of foundations, stopping up of culverts, settlement of tracks on approaches to bridges, surface and alinement of track over bridges, and to make monthly report in duplicate on a specified form furnished for that purpose, sending one copy to the supervisor of track and one copy to the division engineer. The section forces once every month clean all bridge seats, tops of chords, girders and other parts of bridges of any ballast, cinders, dirt and rubbish.

A monthly report of the result of the bridge inspectors' work is compiled by the division engineer on form M.W.50 and sent in triplicate to the division superintendent, who sends one copy to the engineer maintenance of way and one copy to the bridge engineer. The division engineer also makes an inspection of all arch culverts, bridges, trestles and highway bridges at least once every six months, and oftener if the conditions at any structure are such as to require it. He keeps closely informed from the reports received and confers with the bridge inspector as often as opportunity offers, in regard to the condition of the structures and the work necessary for their proper maintenance.

The division engineer is in charge of and is responsible for the proper and safe condition and maintenance of all structures. He is to see that his instructions are carried out promptly, that all necessary repairs are made in rotation of urgency, that the work is of good quality, that during periods of construction and repairs proper precautions are taken to prevent accidents and that the work is kept in a safe condition for the traffic.

The general bridge inspector, reporting to the bridge engineer on form C. F. 9, makes an inspection of culverts, bridges, trestles and highway bridges upon which defects have been reported by the division bridge inspector, or on other structures, as conditions may arise. Reports are made in quadruplicate, one copy for the general bridge inspector, one for the bridge engineer and two are sent to the chief engineer, who transmits one copy to the engineer maintenance of way. The general bridge inspector's work is in no way to interfere with the division bridge inspector's work, but is intended to bring the bridge engineer, and through him the chief engineer, into closer touch with the condition of the various structures, to follow up the carrying out by the division forces of any recommended work and to have first hand detail reports of any defects in structures reported by the division bridge inspector.

In addition to the above, the general bridge inspector makes a regular fall bridge inspection of the whole system, using an engine and car, the division engineer, supervisor

of bridges and buildings and the division bridge inspector accompanying him over their territories, inspecting all arch culverts, bridges, trestles and highway bridges, noting any defects requiring attention, either at once or during the coming season, also noting any renewals required in timber structures, wooden floors for iron and steel bridges, painting of structures, pointing or other repairs to masonry and bridge seats, strengthening foundations, surfacing of tracks on approaches to bridges, planking and other repairs to highway bridges, fences and other protection on structures, etc. A typewritten report of such fall bridge inspection is made for each division and triplicate copies sent by the bridge engineer to the chief engineer, who transmits two copies to the engineer maintenance of way, one for his files and one for the division. Monthly statements of work done by the division forces on repairs to bridges and trestles, etc., are sent by the division engineer to the engineer maintenance of way, who transmits one copy to the bridge engineer for his information and for the checking up of the work outlined in the fall bridge inspection reports. The inspections made by the general bridge inspector or any inspection made by the bridge engineer do not in any way relieve the division engineer, the supervisor of bridges and buildings or the division bridge inspector of any responsibility or obligation to carry out all the rules and regulations relating to the maintenance of all arch culverts, bridges, trestles, highway bridges and other structures in a safe condition.

**ON THE GRAND TRUNK.**

By M. S. BLAIKLOCK,

Engineer, Maintenance of Way, Grand Trunk.

This railway is divided into three grand divisions, 12 ordinary operating and maintenance divisions, and 33 districts. Each grand division has a general superintendent, superintendent of track, superintendent of bridges and buildings, and a division engineer. Each operating and maintenance division has a superintendent, resident engineer, supervisor of bridges and buildings and several supervisors of track.

The organization in regard to maintenance and inspection of bridges is graphically illustrated below:

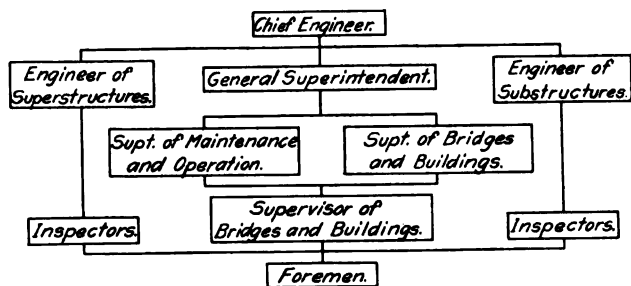

Graphical Outline of Grand Trunk Bridge Organization.

Each operating and maintenance division is a complete unit within itself, reporting to the chief engineer through the general superintendent.

There are two methods of inspection of bridges, one originating with the chief engineer and the other with the division superintendent. The first is done annually and the second periodically, the degree of frequency depending on the importance of the structure, but it is never less than once a year.

Besides the chief engineer, the staff at headquarters is composed of an engineer of superstructures and an engineer of substructures, together with one inspecting engineer for each grand division. When a general inspection is undertaken a gasoline motor car is used, and a party, consisting of the inspecting engineer, superintendent of bridges and buildings of the grand division and the division supervisor of bridges and buildings, makes an examination of each structure. The results of the inspection are kept in field note books, although not in any special form, but on the comple-

tion of the inspections, they are tabulated at headquarters on the following form:

					Bridge No.
Mile from	District	Description			S. or D. Track
Number of Spans	Length of Steel	Distance between back walls	Depth	Specification Loading	Remarks
Date of last Inspection					Remarks

These reports are typewritten on stiff cardboard and filed with a photograph of the structure in cases in numerical order of the districts, for reference in the chief engineer's records. Towards the end of the year, after the inspections are completed, such renewals and repairs as may be required during the ensuing year are considered and determined. Classification is made into new superstructure, new substructure, general changes and general repairs, plans and estimates for such are made accordingly, and contracts awarded in the usual course. The character of the work necessary to maintain, strengthen or replace is made by the structural engineers from the inspectors' reports and recommendations are made to the chief engineer, who forwards them with his recommendation to the executive officer.

In addition to the annual inspection by the chief engineer's staff, there are periodical inspections by the supervisors of bridges and buildings on each division. These supervisors are chosen from the foremen of the bridge and building department and have usually spent their working lives in the same department. As we do most of the renewal of bridges with our own forces, their training is one of actual experience, and they have usually demonstrated their ability in the years they have spent in construction. The supervisors are provided with small motor cars and inspect each structure thoroughly four or five times per year. The results of their inspection are recorded on the following form:

GRAND TRUNK RAILWAY SYSTEM.

.....Division.

ANNUAL BRIDGE INSPECTION REPORT.

I have today inspected Bridge No.....District.....at Mileage....., and find its condition as follows:

- |                      |                          |
|----------------------|--------------------------|
| 1. Ties              | 14. Bottom Bracing       |
| 2. Guards            | 15. Sway Bracing         |
| 3. Stringers         | 16. Wall Pl. or Pedestal |
| 4. String. Conns.    | 17. Expansion Joint      |
| 5. Floor Beams       | 18. Bearings             |
| 6. Floor Beam Conns. | 19. Masonry              |
| 7. Girders           | 20. Caps                 |
| 8. Top Chord         | 21. Piles or Posts       |
| 9. Bottom Chord      | 22. Sills                |
| 10. Ties or Rods     | 23. Line                 |
| 11. Posts            | 24. Camber               |
| 12. Truss Joints     | 25. Paint                |
| 13. Top Bracing      | 26. Miscellaneous        |

The following is required to maintain the structure in good condition:

.....  
 .....  
 .....  
 Date.....19... ..  
 Supervisor.

These reports are filed in the supervisor's office, and duplicates are sent to the superintendent of bridges and buildings and superintendent of operation and maintenance. The superintendent of bridges and buildings refers to these reports

when making the annual inspection with the chief engineer's inspectors and the conditions as shown on these reports form the basis for the official records on the unit bridge card system on file in the office of the structural engineers.

The advantage of this system of inspection is that we have the assistance of the practical man who often has had direct charge of the construction and erection of the structure, as well as the maintenance in addition to the practical as well as the theoretical experience of the superintendent of bridges and buildings, to advise and explain to the inspecting engineers and the structural engineers the precise nature of the weaknesses or defects, as well as the physical condition of the structure in service.

The advantage of the unit card filing system of the reports is its convenience for ready reference.

#### ON THE NEW YORK CENTRAL & HUDSON RIVER.

By A. W. CARPENTER,

Assistant Valuation Engineer, New York Central & Hudson River.

The most frequent inspection is that of the trackmen. This is made daily or oftener by the track walkers and patrolmen and somewhat less frequently by the section foremen. The inspection by these men is of course more or less superficial, but is sufficient to take care of accidents, washouts and other obviously wrong conditions, which do not require trained observation and special knowledge of construction. The track supervisor is required to make a personal examination of every tunnel, bridge, culvert, trestle, retaining wall and sea wall upon his division during each quarter of the year, and on the last day of each quarter to render a report to the division engineer, calling attention to any structure or wall that he considers to need attention in the near future. All employees are required to report immediately any conditions that they may observe which in their judgment are unsafe, taking immediate steps to insure safety until their reports are acted upon.

Each maintenance division employs one or more bridge inspectors reporting to the bridge supervisor. These inspectors are generally recruited from the bridge gangs, and are chosen for their practical knowledge, general intelligence and reliability; sometimes young engineers with proper experience and otherwise qualified are chosen. The bridge inspectors are expected to devote their entire time to the examination of the bridges and culverts in the territory assigned to them, covering all of them at least once during each quarter of the year, and to render a report to the bridge supervisor at the end of each quarter. Instructions to bridge inspectors are contained in the "Rules of the Maintenance of Way Department," the general instructions, aside from those to the effect mentioned above, being as follows:

"In case the bridge inspector finds conditions which he considers dangerous or demanding immediate attention, he shall immediately report it to the supervisor of bridges by letter or telegram as he may deem advisable, and he may call on any employee of the maintenance of way department who may be at hand for necessary assistance.

"Notes of inspectors must be recorded at the structure when the examination is made."

One other rule referring to the inspection of the under parts of bridges over steam-operated tracks deserves special comment and reads as follows: "Overhead bridges exposed to locomotive gases shall be frequently examined. Planking must be removed, or other means taken to determine the conditions at inaccessible places. All parts deteriorated shall be immediately reported." The inspection and maintenance of exposed steel work below the floors of such bridges is apt to be neglected on account of the difficulty of removing the bridge floors, for access to the parts beneath, and the inaccessibility of the parts from below. The above quoted special

instructions have been supplemented by circulars intended to insure thorough inspection of these structures, including the measurement of corroded sections, and the tabulation of the measurements for examination in the office. In order to further facilitate inspection and maintenance, the engineer of structures has, in recent years, when designing overhead bridges with plank floors of sufficient width, shown on his plans the plank cut on the longitudinal center line of the floor, a device which is not a new idea, but which is apparently not used as often as it deserves. With this device, only one-half the width of roadway need be disturbed by the removal of planking sufficient for inspection and maintenance work, thus permitting the work to be done without entirely closing the bridge to traffic, under which circumstances it can be much more readily and efficiently accomplished.

Special instructions to bridge inspectors in the "Book of Rules" cover the particular points to be examined, which from previous experience have been found to be those which are most apt to show wear, defects or need of attention.

The bridge supervisor, reporting to the division engineer, is the road official especially charged with the maintenance of the bridges and the handling of the labor and equipment required therefor. In addition to inspecting promptly such bridges as are reported to him for attention by the bridge inspector, he is expected to personally inspect, at frequent intervals, such bridges as are known to be in a weakened or threatened condition and to exercise the necessary precautions for safety.

Supplementing the bridge inspector's work, in the way of routine inspection, a semi-annual inspection is required of the division engineers, accompanied by their bridge supervisors. The second inspection is scheduled to take place during the months of September and October, and calls for a personal examination of all bridges, trestles, turntables, transfer tables, abutments, retaining walls, culverts, tunnels, etc. The bridge supervisor is required, at the conclusion of each examination, to make reports on the proper forms to be transmitted, through the division engineer, to the engineer of maintenance of way not later than November 1.

The division engineers prepare from the supervisors' reports and submit to the engineer of maintenance of way their recommendations for repairs and renewals for the succeeding year. The supervisors' reports are also scrutinized by the engineer of bridges of the maintenance of way department, who also examines the division engineers' recommended programs, and makes personal inspection of the more important points reported and of all the structures recommended for repair or renewal by the division engineer. The engineer of bridges brings into the field technical knowledge of construction which is not always possessed by the division officers. The engineer of bridges has a special inspector to assist him.

While the maintenance departments are responsible for the physical condition of the bridges, the engineer of structures of the engineering department is charged with the responsibility of determining their carrying capacity. He maintains records of the construction of the bridges and of the calculated stresses in members of those which are susceptible to such calculation. To him are referred reports from the maintenance engineers to the chief engineer regarding deterioration in or injury to structures, or other conditions requiring his more technical services. To the engineer of structures is referred the determination of strengthening of bridges to meet increased weight of equipment and the preparation of the program for such strengthening. The engineer of structures has an inspector who examines and reports on the condition of structures as specially instructed.

The above method has been in vogue for the past ten years or so and has been found satisfactory.

**ON THE MISSOURI PACIFIC.**

By W. K. WALKER,

Division Engineer, Missouri Pacific, Wichita, Kan.

From the standpoint of railroad officials in charge of the maintenance of structures, it is important that thorough inspections be made and complete records thereof be kept to insure the safety of all structures and to convey to these officers a definite knowledge of the condition of each and every structure under their supervision at the time of inspection. To best accomplish this a definite method and time of inspection is followed on the division under my supervision. The system outlined below is the general method of conducting the inspection of structures on the Missouri Pacific System.

In passing over their track the section foremen observe the general condition of all structures. Once each week, and immediately following heavy rains, they stop and examine each bridge, culvert and channel thereof. This examination is made by going under the bridge and carefully looking over all timbers, piers, abutments, etc. They see that all bents are free from rubbish and all culverts are clear of mud, rubbish, etc. Any unusual condition is reported to the supervisor of bridges and buildings and to the general roadmaster or superintendent at once by telegraph. The decks of all bridges are carefully looked over for any defects, especially of line, surface or low approaches.

The supervisor or an experienced bridge inspector makes an inspection of all structures at intervals of six weeks or two months. He is provided with a motor car to enable him to get to all structures without loss of time. The roadmasters also give attention to the condition of structures while passing over their track and report any unusual condition to the supervisor and general roadmaster at once.

Every six months the bridge engineer or his inspector inspects all trusses, girders, large bridges and other structures which may require such an inspection. They examine the supervisor's notes of past inspections to ascertain if they are carrying out instructions regarding inspections.

Each fall a special inspection is made by the supervisor, at which time each structure is looked over carefully and defects noted. The notes are kept in an ordinary engineer's field book and each structure is listed as follows:

Bridge (Building, culvert or stock yard) No.....  
 Location (Nearest station East or North).....  
 Mile Post..... Pole..... No. of Panels.....  
 Length of Panels..... Kind of Structure.....

With the above information it is easy to locate any structure having defects which need attention. In making the inspection of bridges the deck is first carefully looked over, defects noted and recommendations made, after which the under portion of the structure is carefully examined, the defects noted and recommendations made. After all structures on the division have been inspected, the notes are sent to the engineer maintenance of way and a joint inspection is made, determining the program for reconstruction and general repairs to be made during the ensuing year.

This joint inspection is made by the engineer maintenance of way or a representative of the engineering department, expert with reference to structures, the division supervisor of structures, and when possible the general roadmaster or superintendent. Copies of the notes taken by the engineering department representative are furnished the division officers interested, the bridge engineer and the engineer maintenance of way. The bridge engineer specifies which items shall be charged to operation and which shall constitute betterment work. All items of betterment work require special detailed authority beyond the regular yearly program. The receipt of the notes covering the joint fall inspection by the division officers interested constitutes authority to proceed with all maintenance items. The division officers under whose charge the structures come are responsible at all times for the proper

inspection being given the structures as they require and to see that the work of repairs is proceeding in accordance with the inspection notes and that structures are being safely maintained.

At the fall inspection all structures are given a very thorough inspection to determine if there are any weak points. The detail of this inspection in part is as follows: Water ways above and below the structure are looked over to ascertain if they are stopped up. High water records are consulted to ascertain if the opening affords ample water way. Ties, guard rails and sway braces are inspected to see that they are sound, properly placed and fastened in place. Particular attention is given to caps, stringers and piling, especially where they bear against each other and where piling enters the ground or water. Where the structure is six years or more old such members as by their position are particularly liable to decay are tested by boring. The holes so made are plugged up as soon as the inspection is completed.

Examination of masonry, piers and abutments is made with special reference to the joints, settlement, imperfect stones, cracks or other defects. Sketches are made and notes kept of cracks opening up or if any settlement or movement is perceptible. Bed plates and rollers are examined to see that they are clean, that the rollers move squarely back and forth with the trusses, that the pedestals take an even bearing on the rollers and that the anchor bolts are holding properly. The condition of all timbers supporting corbels, wall plates or bolsters is carefully observed to note any appearance of crushing or decay. All packing and chord bolts are examined to see that they are tight.

Connections between stringers, floor beams and connecting angles are carefully examined. The inspection of connections between floor beams and trusses is made for evidence of imperfect bearing, or splitting of connecting angles. A test is made for the equality of tension in tee bars and any signs of distortion or crookedness in bars of end panels or bottom chords is looked for. The center line of all tension members is also seen to be the same as the line of strain. The top chords, lateral struts and posts are examined to see that they are straight and free from twists. On wooden bridges the braces are seen to be in place to take square bearing at the ends and to show no evidence of warping.

Lateral connections are examined to see that lateral tension members are straight. An examination is made of all hangers, testing each nut to see that it is tight and all pins to see if there is any indication of the movement of members coupling upon them or if they have loose nuts. All field driven rivets in floor beams and stringer connections and in bottom chord splices are sounded to see if they are tight. An examination of pedestals and similar members is made to see that they do not catch and retain water by reason of not having proper drain holes. A careful examination is made of the line of each truss by the top chord and by points on the floor beams. The camber is noted by the top and bottom chords. Loose rods, braces and any other defects are carefully looked for. All iron structures are examined for rust spots or other indications showing need of paint.

Culverts are examined for cracks, wing walls giving way, undermining, displacement of riprap and in wooden culverts for rotten members.

This method of inspection has been in practice for several years and has proven very satisfactory. By thus keeping in touch with the exact condition of each structure at all times they are safely and economically maintained. Both division and general maintenance officers are in close touch with the condition of all structures and the time elapsing between inspections is so short that any unusual giving way of any member of a structure is quickly noticed and the remedy applied. By frequent inspection and the replacing of only such members of a structure as show signs of failure, we are enabled to get the major portion of the life of each member.

In the case of concrete and steel structures we are enabled to repair any weak points and thereby lengthen the life of the structure at a minimum cost.

#### ON THE SOUTHERN PACIFIC.

By G. W. REAR,

General Bridge Inspector, Southern Pacific.

Bridges, trestles and culverts on the lines of the Southern Pacific are inspected daily by trackwalkers and section foremen; quarterly by bridge and building supervisors, and annually by the general bridge inspector, division engineer and bridge and building supervisor. Certain structures are given special inspections as may be considered necessary.

The daily inspection consists of a casual examination as the track inspectors pass over the road and is intended mainly to disclose any unusual condition that might be caused by accident, high water, etc. No written report is made of this inspection, any defects found being reported to the roadmaster by wire or letter, as conditions may require.

The quarterly inspection is not as thorough as the annual inspection, but is for follow-up purposes and is intended to show what repairs are being made and to see that no defects occur that might prove serious before the next annual inspection. This inspection mainly includes the visible defects and is not intended to cover decay and other defects not readily observed. A written report of this inspection is sent to the assistant chief engineer.

The annual inspection is made at the most favorable time of the year, beginning with the most southerly lines in winter and finishing with the central lines in the fall. This inspection takes up practically all the time of the general bridge inspector and is very thorough in character, showing the exact condition of each bridge, trestle, culvert, etc. The inspectors pass over the road on gasoline motor cars and examine each structure in turn, all inspection notes being entered in a book, copies of which are furnished to the assistant chief engineer, the district engineer and the division superintendent. The book is a bound volume of white prints made from tracings, having pages 5 x 8 in. in size, alternate pages being left blank for notes. The left hand page contains the following information: Number, kind of structure, length, height and date built. Sufficient space is left for full inspection notes, several blank pages sometimes being left for one structure if necessary. Each year the tracings are corrected and new books bound. This results in cutting down a very large amount of the writing in the field and the inspectors have a complete record of the structures before them. During the year, as repairs or renewals are made, notation is made in these inspection books for the information of those concerned.

Culverts are inspected to see that they are not crushed, cracked or stopped up with drift. If the culverts are of wood, the condition of the timber is shown. Trestles are given a thorough inspection, the amount being governed somewhat by the age of the structure. Where considered advisable, the soil is dug away from the piles for about 18 in. in depth before the inspection is started, a list of the trestles to be so treated being furnished the roadmaster in advance.

The tools used for inspection are a steel bar and a brace and  $\frac{3}{8}$  in. car bit. The bar is of  $\frac{5}{8}$  in. octagonal steel about 5 ft. long, is pointed at one end and with a ball  $1\frac{1}{2}$  in. in diameter at the other end. Usually the bar has a rubber grip handle close to the ball end. The timber is prodded with the point of the bar to ascertain the amount of external decay and is struck with the ball end to sound for internal decay. If the sound indicates decay the timber is bored with the  $\frac{3}{8}$  in. bit. Usually the piles are inspected first and a note made of their condition and, if decayed, the amount of sound wood remaining is measured. The condition of the bracing is next examined and then the caps, stringers, ties and guard

timber. The condition of the fire apparatus is noted; also any lack of care in keeping brush or grass cut away.

Steel structures are given a close examination, especially those which are not of recent construction. The rollers and bed plates are examined, the line and surface noted and a close inspection made for loose rivets, nuts, etc. All hitch angles are examined for cracks and, the behavior of the span under traffic is observed. The older and lighter spans are examined closely for cracks, cut pins, etc. On draw-bridges the machinery is looked over and the bridges are opened for a test of the machinery and operation. The condition of the rails and protective devices is also noted; masonry and concrete substructures, arches, etc., are examined for cracks, settlement or undermining and any change in depth of water or direction of current is noted.

Wooden trusses are examined for decay and for structural defects such as sheared splices, cross grained checks, etc. It is customary to mark a structure "good" if nothing is found to be wrong and confine the remarks to those things found to need attention. A short report of the general condition is often made about as follows: "Trestle 12 years old, fair state of repair, probably require renewal in two to three years." From these annual inspection reports the annual budget of repairs and renewals is made and the repair work and small renewals are carried out along the lines agreed upon by the inspector while on the ground. The larger renewals are usually given special inspection and special plans provided by the assistant chief engineer.

One important advantage of this system is that the operating officials and the head of the maintenance of way department are represented on the ground at the time of the inspection and any difference of opinion can be settled with all the conditions before them.

#### ON THE PENNSYLVANIA RAILROAD.

As there are practically no timber structures remaining on the Pennsylvania, the method of inspection in force on this road is designed for steel structures. A master carpenter is assigned to each division, reporting to the division engineer. One or more inspectors are employed on each division, depending upon the mileage and the number of structures, these inspectors reporting to the master carpenters. These inspectors spend their entire time examining structures and a sufficient number are assigned to each division to enable every structure to be inspected monthly. They are taken from the regular bridge gangs and before appointment are either foremen or leading men in gangs.

Each inspector works alone and makes a daily report to the master carpenter of the structures examined. At the end of the month these daily reports are combined by the master carpenter into a monthly report, which is sent to the division engineer. At intervals of three months, copies of the last monthly reports are sent through the division engineer, superintendent and general superintendent, to the engineer maintenance of way that he may be kept informed of the conditions of structures.

In addition to these monthly inspections the division engineer, accompanied by the master carpenter, foreman carpenter and mason, make an inspection of all bridges in April and October of each year. At the fall inspection special attention is given to the repairs and renewals required for the coming year and a program of such work is prepared and submitted for approval.

As a check against the thoroughness of these inspections by the division forces, three special technically trained inspectors reporting to the engineer maintenance of way, spend their entire time making detailed inspections and examinations of the different structures. They visit all structures on the road and are enabled to cover all of the lines east of Pittsburgh at intervals of about every nine months. In making these examinations the general inspectors take the



master carpenters and division inspectors with them whenever possible in order to train them in proper methods of inspection and to secure uniform standards of inspection on the various divisions. These inspectors make recommendations to the engineer maintenance of way, who transmits them to the division officers and then follows them up to see that the recommendations are carried out.

The assistant engineer maintenance of way, bridges and structures, on the staff of the engineer maintenance of way, makes a general inspection of all bridges on the lines east of Pittsburgh with the division engineer, master carpenter, division inspector and the general inspector who last covered the division, at intervals of about 18 months. This inspection is to a certain extent general in nature.

In addition to these inspections by the bridge department, the track supervisors are also held responsible for keeping the bridges and culverts in repair and the track foremen are required to examine all structures in their territory frequently and to assure themselves of their safety.

#### ON THE CHICAGO, BURLINGTON & QUINCY.

The rules of the Chicago, Burlington & Quincy provide that all bridges be inspected daily by the track forces; monthly by the bridge foremen, or sub-foremen; semi-annually by the master carpenter and annually by the bridge engineer. The daily inspection by the track forces is to discover any unsafe conditions of the structures resulting from storms, derailments, etc., and is very general in character.

A monthly inspection of all timber bridges is made by the bridge foreman or sub-foreman, who reports on a special form all derangements and defects, notifying the master carpenter by wire in case immediate repairs are needed and giving him a list of material required. At least once each year in advance of the annual spring inspection made by the master carpenter, the foreman digs around the pile bents to observe indications of decay and chops away all decayed material to its full depth, leaving the earth excavated so that the master carpenter can ascertain the extent of the decay without labor. In the monthly inspection, particular attention is paid to the caps and each cap which shows any signs of decay or weakness is bored into or otherwise thoroughly explored. At the end of each month a report is made out by the master carpenter and sent to the division superintendent, giving a summary of all bridges inspected during the month with the date on which each was inspected and the general condition of each bridge.

All bridges carrying traffic of this company are inspected at least semi-annually by the master carpenter personally. All other bridges and all culverts maintained by, or at the expense of the company, are inspected at least annually by the same officer. The notes of these inspections are kept in a special bridge inspection book and show the condition of every bridge and culvert in main and side tracks. These notes show the length and height of each bridge; the length, width and height of all overhead bridges and culverts; type of structure; condition, and if repairs are required during the ensuing year they give a concise statement of the condition of the various portions of the structures. The notes of the fall inspection show the material which will be required for repairs and renewals during the ensuing year, measurements being made to determine the length of piles required and soundings being taken where the ground is soft. Where the structure requires renewal or extensive repairs, the notes show where any filling in can be done and give the kind and size of opening required to carry the water. A copy of the notes of the fall inspection as made by the master carpenter is forwarded to the engineer maintenance of way as soon as possible after the inspection is completed.

The spring inspection is made as early as possible and the notes show whether the work outlined is sufficient to maintain the structure in a safe condition until the following spring. A copy of these notes is made by the master carpenter and

also forwarded to the engineer maintenance of way as soon as possible after the completion of the inspection.

A condensed report of the fall inspection is made by the master carpenters and sent to the bridge engineer showing every bridge or culvert upon which it is anticipated that it will be necessary to spend any money during the ensuing year, with the recommendation of the master carpenter thereon. Copies of this are sent by the bridge engineer to the district engineers for information as to the drainage, contracts for cattle passes or undercrosses, etc. Wherever possible, the master carpenters show on this report the cost of carrying over or repairing such bridges and culverts as are reported, with the estimated length of time such repairs will make the structure safe.

The bridge engineer makes an annual fall inspection of all bridges having spans of over 24 ft. and including all culvert and timber bridges reported by the master carpenters to require renewal. The bridge engineer's report of this inspection includes not only his recommendations for current repairs to permanent structures but also recommendations for the renewal in kind or replacement of the culverts and temporary bridges reported by the master carpenter.

In addition to these regular inspections, frequent examinations are made as necessary of bridges and culverts which show signs of serious deterioration. The master carpenters are responsible for the safe condition of all bridges and culverts on their division and their reports of special inspections are made in the same manner as regular inspections.

#### ABSTRACT OF ENGINEERING ARTICLES SINCE OCTOBER 24.

The following articles of special interest to engineers and maintenance of way officers and to which readers of this section may wish to refer, have appeared in the *Railway Age Gazette* since October 24, 1913:

New O.-W. R. & N. Terminal in Spokane.—The O.-W. R. & N. is expending approximately \$7,000,000 in the construction of extensive new freight and passenger terminals at Spokane, the passenger terminals being shared with the C. M. & St. P. These terminals were described in an illustrated article in the issue of October 31, page 817.

New Mississippi River Bridge at Memphis.—The Arkansas & Memphis Railway Bridge and Terminal Co. was organized a year ago by the Rock Island, the Iron Mountain and the Cotton Belt railroads to construct a double track railway and highway bridge across the Mississippi river at Memphis. This structure will be 2,548 ft. long with a channel span 790 ft. in length, and its general features were described in the issue of October 31, page 824.

A Division Office Building Designed for the Hine System of Organization.—The Arizona Eastern is operated under the Hine system of organization. A new division office building is now being built at Phoenix which has been designed to carry out the Hine system of organization. This building was described in the issue of October 31, page 827.

Construction of Clinchfield Extension.—One of the heaviest and most interesting pieces of construction work now under way in this country is that of the Carolina, Clinchfield & Ohio from Dante, Va., to Elkhorn, Ky., to give a northern outlet for the coal originating along this line. This extension is 35 miles long and is costing over \$140,000 per mile. There are 20 tunnels with a combined length amounting to more than 11 per cent. of the total length of the line. This extension was described in a comprehensive illustrated article in the issue of November 7, page 861.

Summit-Hallstead Cut-Off of D. L. & W.—The Delaware, Lackawanna & Western is now constructing a new three track line from Clark's Summit, Pa., seven miles north of Scranton north 40 miles to Hallstead at an expenditure of about \$12,000,000. This line comprises some of the heaviest railway work ever undertaken in this country. The first of a series of two comprehensive illustrated articles describing this work was published in the issue of November 14, page 903.

PROPOSED RAILWAY IN MOROCCO.—Engineers have left Tangier for Casablanca to survey the route of the proposed railway from Tangier to Fez. Afterwards they are to journey to Rabat where they will survey the route of the proposed new line across French territory which will pass through Souk-el-Arba and Le Gharb, and will extend to Lalla-Ito and thence to Meknès and Fez. The work is to be begun in September of next year and is expected to last about two years.

# THE LACKAWANNA FROG AND SWITCH SHOPS.

All Frogs, Switches and Special Track Material Made. Track Scrap Handled and 50 per cent of Small Scrap Reclaimed.

The Delaware, Lackawanna & Western has operated a frog and switch shop for the manufacture of frogs, switches and miscellaneous track material, at Kingston, Pa., for a number of years. The facilities at this point, however, have been gradually outgrown and this shop was moved on December 1, 1912, to Dover, N. J., where the company already owned a large brick building built originally as a shop for the car department, but more recently leased to an outside concern after the car shops were moved to Scranton. At this shop all switches, frogs, switch stands and many special track fastenings such as compromise joints, heel blocks, etc., as well as many track tools are made. All track scrap from the system is likewise shipped here, sorted and held for sale by the purchasing department.

while the smaller ones are grouped. Power is secured locally from an outside plant. About 100 men are regularly employed at this shop.

## THE SWITCH DEPARTMENT.

The operation of the shop can best be seen by following the material through the process of manufacture. Taking a set of switch points, for example, the rails are brought into the shop on standard gage cars and unloaded directly by air hoists onto storage racks in the southwest corner of the main building. From the racks the rails are taken to the saws and then to a four-spindle drill press where they are drilled for the joints and reinforcing bars. They then pass to a riveting

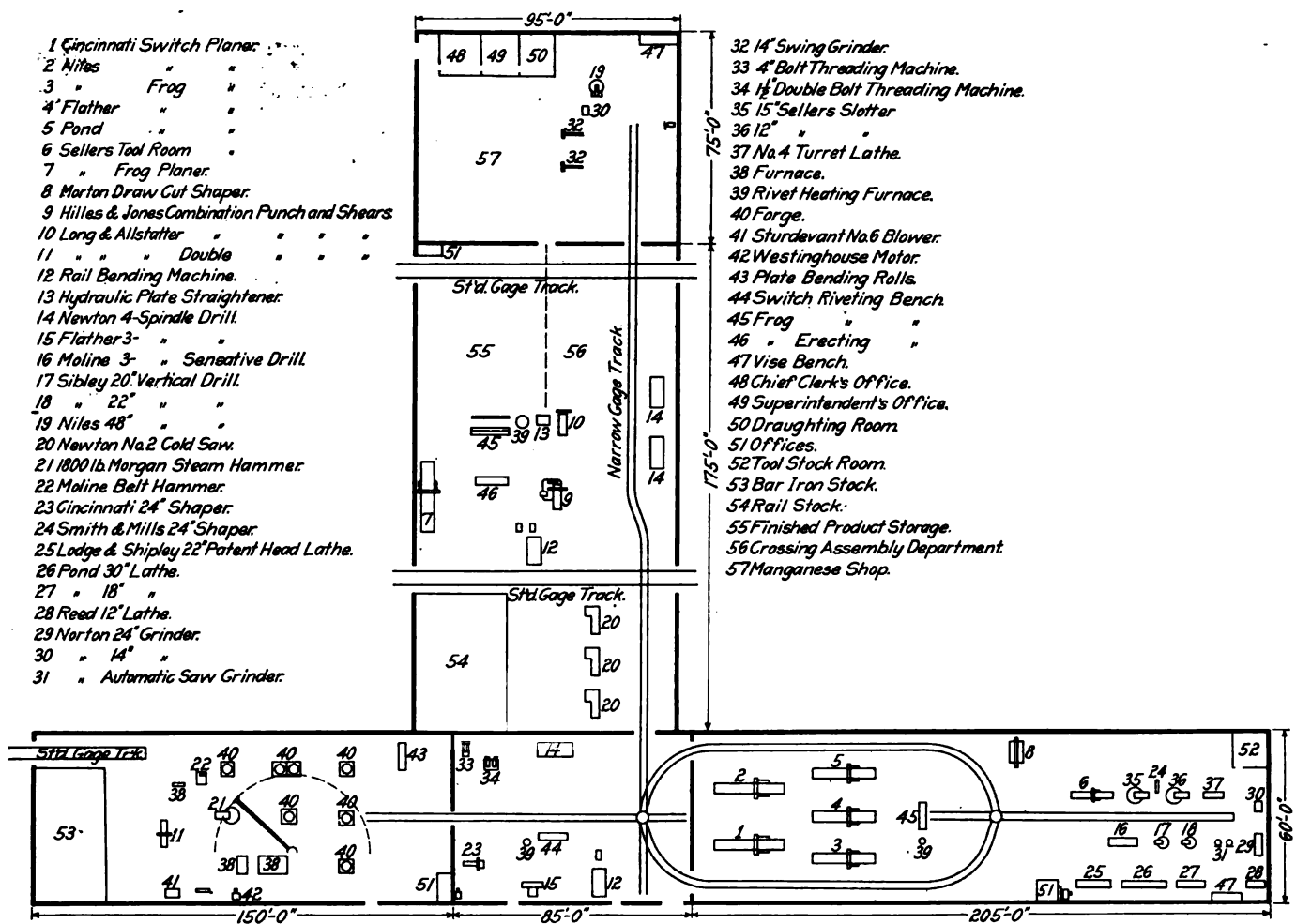

Floor Plan and Arrangement of Tools of D. L. & W. Frog and Switch Shop.

The Dover shop consists of two buildings connected to form a T, as shown in the photograph and plan. In brief, the manganese shop occupies the north end of the main building while the south end of this same building is devoted to the rail stock and the frog assembling shop. The frog and switch planers and other heavy machinery are located in the east end of the annex while the blacksmith shop occupies the west end of this building. The scrap yard is located just back of the blacksmith shop. These buildings are situated adjacent to the main line with standard gage tracks leading into them and into the scrap yard. Overhead runways with air hoists are provided throughout the buildings and scrap yard to handle all heavy material. All tools are electrically driven, the larger units being equipped with individual motors

bench in the next room where the reinforcing bars are partially riveted on and are then loaded on a narrow gage car and taken to the two switch planers in an adjacent room. The first planer cuts down the head only, working on two rails at a time. After the head is planed to the proper dimension, these rails are transferred by an air hoist to another adjacent planer which cuts down the flanges. The points are then loaded onto a small car and returned to a bending machine. After being properly bent they are placed on a riveting bench and the riveting of the reinforcing bars is completed. At no point in their manufacture are the switch points more than 60 ft. from the saws and they are loaded for shipment within 50 ft. of the rail pile.

These switches are made of 80 lb., 91 lb. and 101 lb. rails,

the latter two weights being of new open hearth rails, while the 80 lb. switches are made of second hand rails to match up with the second hand rail in the track, no new rail of this weight now being laid. The switches are made in 10 ft., 15 ft., 16 ft. 6 in and 20 ft. lengths, while some 30 ft. switches are now being manufactured. These switches are provided with riser plates punched for screw spikes, with insulated connecting rods for main line work, with malleable skeleton heel blocks, malleable switch braces, forged steel switch lugs, adjustable head rods, etc., and are shipped out from this shop complete and ready for installation. The output of this portion of the plant is 140 complete switches per month. In

the rail is passed to the second planer which cuts down the flange. The side and point rails are then riveted together and taken to the third planer, where the point is cut down. The frog is then brought back to the first room and is sheared, punched, drilled and bolted and riveted together, all riveting being done by air hammers. The manganese frogs are assembled in an adjoining room provided with swinging grinders and other surface grinders.

**MISCELLANEOUS MATERIAL.**

All switch stands for main line and yard tracks as well as those for the mining department are made here. About 125



**Exterior of Frog and Switch Shop Before Old Debris Was Cleared Away.**

addition an average of 60 switches are made monthly for the coal mining department. These latter switches are made of 40 lb. rail, are from 5 to 7 ft. long and are equipped with two rods and plates.

**THE FROG DEPARTMENT.**

About 170 frogs are turned out monthly for the railroad, in addition to 60 for the mining department. Those for the railroad are made of 91 and 101 lb. new rail and of 80 lb. relaying rail, short pieces of rail saved when cutting rails for track connections being utilized largely for the new frogs. They are of the riveted type of construction. A 7/8 in. base plate is regularly used as a means of protection for the ties.

stands are turned out monthly for the railroad and 36 for the mines. A high quarter-throw stand is used for main line work and a low stand for yards, while a jack knife stand is used in mine work. All stands for the railroad are made of malleable iron and are mounted on the head blocks, bolted in place and shipped set up to avoid the use of cut spikes.

A large amount of miscellaneous track material is also made at this shop. Over 100 guard rails are made monthly for the railway alone. All guard rail filler blocks, plates and rail braces are also made here. About 350 pairs of compromise joints and 220 insulated joints are made monthly as well as



**View in Frog Erecting Shop Showing Riveting Benches and Finished Products Storage.**



**The Three Frog Planers.**

Some manganese insert frogs are also made at this shop, the manganese castings being purchased outside.

In assembling a frog the rails are taken from the rail pile to the saws as described above. From the saws the point and wing rails move to a three-spindle drill press and are then taken to a bending machine where the wing rails are bent. The rails are then loaded on a narrow gage car and taken to a battery of three frog planers. The first planer cuts down the head to the required dimension, after which

an average of six crossings and slip switches. The standard metal fencing required for station grounds, etc., is manufactured at this shop, over 14,000 lineal ft. of this fencing being turned out last year while as much as 50,000 ft. has been made in one year. All cattle guards are made in this shop. All push cars are also made and repaired here. All screw spike tools, track gages, level boards, ballast templets, sighting boards, lining boards, overhead clearance indicators, freight yard cranes, repair parts for rock crushers and screens

and many other miscellaneous track supplies are turned out at this shop. In making crusher screens for rock crushers, \$20 per set is saved by utilizing cuttings, the cuttings are made into washers for fencing and other work. The output of the Kingston shop for the 12 years previous to the removal to Dover was 22,287 switches, 25,545 frogs, 16,933 guard rails, 10,684 switch stands, 34,414 compromise joints, 28,836 insulated joints and 618 crossings and slip switches.

A recent incident illustrates the advantage of such a shop

is then picked up monthly, the car scrap being loaded separately from the track scrap. The track scrap is sent to Dover and is there unloaded. This scrap is carefully sorted into three varieties and each variety into three grades. The small scrap such as bolts and spikes are thrown into bins, the material being sorted over and the portions fit for further use reclaimed at the time of loading. Angle bars and track joints are neatly piled at another location. All frogs are piled by themselves, as shown in the accompanying photograph, until a sufficient number is gathered together, when they are broken up. All material not reclaimed is held for sale by the purchasing department and is loaded and shipped upon its instructions.

All frogs are cut apart before sale and a large amount of material such as fillers and plates is reclaimed. As one instance of the saving effected the cost of a new base plate is \$3.85. When a frog is worn out and the plate comes into the shop for the first time, it is turned end for end and over and placed under another main line frog. When it comes back the second time it is cut off and placed under a shorter frog for yard service. A number of plates which have come back the third time, have been used as a floor in the Dover shop, as shown in one of the accompanying photographs. It is because of the large amount of material reclaimed from



View of Switch Assembling Room.



Machine for Breaking Rivets In Frogs at the Dover Shops of the Lackawanna.

for handling emergency repairs. A steam shovel broke a main shaft recently on Saturday forenoon. The general office was advised and although the frog and switch shop had closed for Saturday afternoon before word could be gotten to it, arrangements were made for certain men to work that afternoon and Sunday repairing the shaft. Accordingly, by the time the shaft reached Dover that afternoon machinists were on hand to begin work upon it. As a result the shovel was able to begin work at 10 o'clock on the following Mon-

frogs that their cost has been reduced to such an extent that manganese has not been justified to the extent commonly found on other roads.

A new machine has recently been devised by the superintendent of the frog shop to break off the rivets in the frogs. This machine consists essentially of an air hammer mounted on a small car. After the frog is securely mounted in position, this hammer moves from rivet to rivet, breaking them out one at a time. It has broken as many as 6,000 rivets in one day and has reduced the cost of breaking up frogs from \$0.87 to \$0.13.

Bolts and spikes are reclaimed as the material is being loaded for sale, two men picking out the good material as two other men load the scrap. The spikes are straightened while the bolts are rethreaded and provided with new nuts. In October and November, 1912, there were reclaimed from the track scrap, 610 kegs of spikes and 384 kegs of bolts. The scrap value of the bolts was \$0.67 per keg, the nuts cost \$1.10 per keg, the labor of sorting and rethreading the bolts and applying the nuts cost \$0.57 per keg, making a total cost of \$2.34 per keg for material having a reclaimed value of \$4.40, showing a saving of \$2.06 per keg. The scrap value of the spikes was \$1 per keg, and the cost of sorting \$0.20, showing a net saving of \$1.88 per keg. The saving due to this reclaimed material in these two months for spikes was \$1,146



Portion of Scrap Yard Showing Frogs Held for Breaking up in Foreground and Scrap Bins in Background.

day morning, where, if it had been necessary to handle repairs through the regular mechanical organization, the shovel would have been laid up at least several days.

RECLAMATION OF SCRAP.

A very important part of this plant is that devoted to the handling and reclaiming of scrap. All track scrap other than rail is sent here from all parts of the system. Saturday is generally observed as a cleaning up day and the section forces collect all scrap at convenient points for loading. This scrap

and for bolts \$791, or a total of \$1,937. The above cost figures include interest on the money invested in the plant and 50 per cent. of the labor charge added for supervision.

Similar savings are also being made with switch stands, 60 per cent. of the stands sent out being stands repaired with material reclaimed from scrap. A low stand sent in as scrap is rebuilt in this manner at a cost of about \$1.25. Likewise, the planer chips are sold as scrap, returning sufficient revenue to pay the cost of the tool steel and the planer operators.

About 7,000 tons of roadway scrap is handled annually at Dover at a total cost for handling in and out of \$0.40 per ton. The economies resulting from this attention to the handling of scrap have been illustrated by the instances given above and are further emphasized by the fact that 50 per cent. of all material received here other than rails and angle bars, is reclaimed.

This shop is operated under the general supervision of G. J. Ray, chief engineer, and A. J. Neafie, principal assistant engineer. C. B. French is general foreman in direct charge of the frog and switch shop.

## METHODS OF REDUCING ACCIDENTS.\*

By R. HOLLAND,

Division Roadmaster, St. Louis & San Francisco, Neodesha, Kan.

While the most attention in the "Safety First" movement has been directed towards the elimination of dangerous conditions in the transportation and mechanical departments, I feel this has also been handled vigorously by the roadmasters and superintendents directly with the maintenance men. There are a number of wrong practices which require attention continuously. Many foremen fail to see that their men place the tools properly on the hand car. The track jack is placed on the front of the car when it should be placed on the rear. Tools are often placed so that they will jostle down against the wheels when the car is in motion and it is customary for laborers to replace them while the car is moving, in this way giving rise to a great many injuries. I recall one instance recently when a track chisel was placed on a hand car where one of the men working on the back lever would stand. The laborer stepped on the chisel, turning the handle upward and catching his hand between the handle of the track chisel and the hand car lever, breaking a finger. Had the chisel been properly placed on the hand car, this accident would not have happened.

It is a common occurrence for trackmen to take chances in rounding curves where the view is obstructed. To cover this, I have issued instructions to all section foremen on my division that the hand car be stopped at all points where the view is obstructed and a flagman sent ahead to insure absolute safety. Men are very often injured in taking the hand car off the track in an unfavorable place. I have built from two to four hand car harbors per mile to avoid this.

Some foremen work their entire gang of four to six men in a bunch. This is not only dangerous but is not the proper way to get results, for by working them close together the men are often injured by tools. In renewing ties, they should be divided into pairs and the pairs should not be worked closer than 15 to 30 feet apart. In this way we are getting good results and have not had an injury from this cause.

Where we have a small force, I never allow men to handle rail by heaving it, but require them to use skids and furnish them with two pieces of rope with hooks on one end with which to hold the rail. The skids are oiled slightly, and the rail pulled up in this way. The men can load more rail and do it quicker and easier than by heaving the rail onto the car in addition to eliminating the personal injuries.

There are probably more trackmen injured in cutting rail than in any other work they have to do. I do not believe this is caused by defective tools such as battered sledge faces or chisel

heads as much as by the manner in which the work is done. In many cases where a man is struck in the face or eye by what is supposed to be a fragment from the chisel head or sledge face I have found that it is a fragment from the rail caused by the chisel not being placed on the same cut on the rail. In this case the chisel was struck before the man holding it could place it in the original cut, and as a result an additional fragment was cut from the rail. It is natural for the laborer who is handling the sledge to strike it too quickly and too hard.

Many trackmen are injured when distributing ties from cars. It is the general practice for the foremen to get on the ground, leaving the laborers in the car to do the unloading. Many of the men are not experienced in handling ties and are injured. I have issued instructions that when unloading ties, there must be one or two foremen in the car with the men to instruct them how to handle and unload the ties without injuring the men engaged in the work.

I believe that 95 per cent. of the personal injuries to maintenance men are caused by the foreman not properly handling the work. A great many foremen do not like foreign labor and for this reason never show the men how to do work properly. I can recall one instance where a foreman was ditching a cut on a heavy grade, the material from the cut being moved to a fill 300 ft. east of the cut by push cars. In order to brake the cars a 2 by 4 piece of scantling was placed under the frame of the car and on top of the wheels. The foreman allowed a laborer to use this brake device on the front wheel of the car, resulting in throwing him from the car and injuring him badly. Had the foreman used the device on the back wheel, the accident would not have happened.

The roadmaster should be in close touch with his foremen and have constant supervision over them, instructing them fully regarding safe methods of doing work. My observation is that when you have educated the foremen regarding the proper manner of handling their men, you have accomplished a great deal.

## COMMITTEES OF THE ROADMASTERS' ASSOCIATION.

The following subjects have been selected for investigation by the Roadmasters' & Maintenance of Way Association for the coming year:

New and Improved Manual and Power Driven Track Tools, J. W. Dahl, N. Y. C. & H. R., chairman; Coleman King, L. I.; H. E. Astley, N. Y. N. H. & H.; P. H. Madden, C. M. & St. P.; D. O'Hern, E. J. & E.; C. J. Coon, N. Y. C. & H. R.; G. H. Brooks, St. L. T.; J. J. Duffy, C. & I. W., and D. Foley, M. C.

Proper Organization and Economical Use of Labor and Material for the Safe Maintenance of Track, P. J. McAndrews, C. & N. W., chairman; William Shea, C. M. & St. P.; Emmett Keough, C. B. & Q.; J. O'Connor, M. St. P. & S. S. M.; W. E. Haberlaw, C. R. I. & P.; M. Griffin, C. R. R. of N. J.; T. Hickey, M. C.; W. E. Davin, P. & L. E., and A. E. Hansen, A. T. & S. F.

Proper Method of Rail Renewal, A. M. Clough, N. Y. C. & H. R., chairman; W. J. Edwards, A. G. S.; C. H. Gruver, C. R. I. & P.; J. H. Reagan, G. T.; John Shea, D. & I. R.; J. E. McNeil, A. T. & S. F.; T. Hughes, N. & W., and M. J. Connerton, C. N. O. & T. P.

Proper Type of Track Accessories, M. Donahoe, C. & A., chairman; G. Beckingham, G. T.; J. A. Roland, C. & N. W.; I. C. Ellison, St. L. I. M. & S.; J. B. Mabile, C. R. I. & P.; J. H. Cummings, B. R. & P.; A. M. Anderson, C. M. & St. P., and T. Mahoney, B. & O.

Cleaning and Policing the Right of Way from the Standpoint of Safety and Economy, J. P. Corcoran, C. & A., chairman; Edward Leaton, C. G. W.; M. Murphy; Joshua Buel, A. C.; S. L. Purdy, A. T. & S. F.; A. A. Wells, Southern, and H. T. Reinicker, N. & W.

\*Received in the contest on "Safety" which closed October 25, 1912.

# SUGGESTED MEANS FOR HOLDING LABORERS.\*

Continuation of Discussion of Practical Methods for Retaining  
Employees in the Track Department; Care of Men Essential.

## HOLDING LABORERS UNDER ADVERSE CONDITIONS.

By W. K. WALKER,

Division Engineer, Missouri Pacific, Wichita, Kan.

Working in a section of the middle west, where 70 per cent. of the laboring class are following agriculture for a living, the maintenance officials of railroads are continually on the lookout for some method to put into practice, which will induce competent laborers to enter and stay with track and structure maintenance work. It is a comparatively easy matter to organize extra gangs for construction work at almost any period of the year. However, this question assumes an entirely different light on regular section or structure gangs, which employ on an average the same number of laborers each summer, with only a slight reduction during the winter. The question of holding the same men for several months at a time in the face of offers of advanced wages by contractors doing municipal or other than railroad work, or by farmers or ranchmen during a few months in the year when agricultural work is at its height, or of offers of better wages and less work, (easy foremen) on other roads, is a difficult one to settle satisfactorily.

I have been fighting this labor question in this same territory for the past eight years, and only in the last two years have I been able to make very much advancement. Recently I have been able to realize to a limited extent the fruits of my efforts to provide conditions that would hold men on my sections the year round. I have seen the time when the sections would not average one half man each during harvest. However, in the past two years there has never been a time when I had less than two men to a section. Among the means adopted to secure this improvement are the following:

On 175 miles of this division—which is that portion of the territory on which I had the most trouble in holding men—gasoline motor cars have been installed, replacing ordinary hand cars. Many times men working on section and structure gangs have said that they liked their work, except the hand car portion of it. With the hand car eliminated and the men going to and coming from work on a motor car, they are remaining on the section months at a time, whereas before they never were known to work any longer than to make a small "stake." Also with motor cars the men do not lay off one to three days out of each week, as they did when we used hand cars. I consider the motor car of very great service in the holding of laborers on sections.

Another inducement I offer men who stay with me, is promotion to the position of foreman as fast as they are competent, and when there are openings, I make it a rule never to hire outsiders as foremen. The men all understand that they are not going to be run around by some floater and they work to merit the promotion when it may come. During the summer months the regular section foremen are used on the extra gangs, in order to give them the extra pay. During the time the regular foremen are on extra gangs, men are advanced from laborers to acting section foremen. This not only gives them an incentive to work on the section, but helps to provide foremen as they are needed. It is a very easy matter now to put on several new foremen on very short notice.

Even with the use of motor cars and the offers of advancement in position there are sections of the country where we are unable to obtain resident laborers. At these points we import foreign labor. The class of foreign labor used is Mexican. No other class of foreign labor is employed here to any extent. In order to hold the Mexican, one is compelled to provide living quarters.

Any old shack will not suffice. A Mexican likes comfortable quarters, and the road that provides the best quarters is the road that has the least trouble in holding these men. If one is lucky enough to get hold of a Mexican family, and will furnish comfortable quarters, nine times out of ten he will have a laborer who will stick to the job.

Good quarters can be provided for Mexican laborers at a very small expense. I have taken care of this by utilizing a number of old bunk cars, which were unfit for road service. These were dismantled, the old car body was set up on blocking, the doors and windows were repaired and the inside sealed. A partition was put in near the center, which divided the car into two parts with one end for sleeping quarters, and the other for cooking, eating and other purposes. A heating stove is provided for the sleeping end of the car. I have never made it a practice to furnish these men with fuel during the winter months, but it is my opinion that this would be a great help in holding men.

One other model and economic way of providing living quarters for Mexicans is to build houses of old ties placed on end, cracks being filled with stiff clay. The roof is sometimes made by using timbers for rafters and putting on a straw and sod roof. The house is then whitewashed inside and out, the use of cold water paint being better for a white wash than lime. These houses can be built of any size desired. They are on the style of the adobe house used in Mexico, and the Mexicans prefer them to the bunk car or bunk house. I am informed by Mexicans who have lived in these houses that they are very warm in the winter.

Until a laborer can get sufficient funds ahead to pay as he goes, the company allows the foremen to arrange with some resident merchant to furnish the men with supplies, and he makes board deductions from the laborer's earnings. Deductions are not allowed to be made for the full amount of the check earned, as pay day is something to be looked forward to and it makes the men feel better satisfied to know that when it comes each month they have real money coming to them. For this reason we only allow 70 per cent of a man's wage to be deducted for board, etc.

The treatment of laborers by the foreman has a great deal to do with his success in holding men. Every foreman should get a full day's work out of every man on his gang every day, but I do not believe in working men to the limit of their capacity. A foreman must make a study of every man on his gang—and each man must be assigned to the work he is best fitted for. He should be firm with his men and see that they do their work well. At the same time he should be kind and always willing to help the men out when he sees that they need his help. The foreman who treats his men with kindness, combined with firmness and sees that his orders are properly obeyed, is the foreman who has the least trouble in holding men on his section.

The problem of holding laborers varies widely in different sections of the country. Each class of foreigners requires different treatment and accommodations. One must study the class of men he is working, become familiar with their peculiarities and try to meet them. A laborer who is pleased with his surroundings and likes his foreman is not going to quit just to be roaming around the country.

I do not think there is any one reasonable thing that can be done by all maintenance officials alike that will hold laborers, but each one must work out his own problem. He cannot apply the same rule to his entire division but must make a study of each section and try to meet the requirements of the section. While the foregoing methods have helped me a great deal, no one of them will apply by itself. It is the combination of them that has

\*Four papers on this subject were published in the issue of October 24, 1913, page 771.

enabled me to hold some men at all periods for the past two years.

### PRACTICAL SUGGESTIONS FOR HOLDING FOREIGN LABORERS.

By A. M. CLOUGH,

Supervisor, New York Central & Hudson River, Batavia, N. Y.

There is no question but that the longer one can keep laborers in the same occupation the more proficient they become, providing, of course, that they are under the proper supervision and are properly instructed. This can only be accomplished by the foreman or those immediately over the men keeping at a respectful distance from them socially and ruling them in a firm yet appreciative manner. In no place more than in the maintenance of way department are foremen and laborers brought more closely together, traveling to work in the same coach or work train caboose or on hand cars, and sometimes eating their noon-day meal under the same shade trees. Bad results have frequently been noted where a foreman mingles with his laborers, playing cards or otherwise being unduly familiar with them while off duty, after which they will try to take the same liberties with him while at work. The roadmaster or foreman who would command the respect of his men will find the least cause to discharge them and also insure his men staying with him or returning to him year after year, in case of summer forces, by rigidly observing the following rules: If a native foreman, he should select an intelligent assistant foreman or interpreter of the nationality of the majority of his men. If a foreign foreman, he, of course, should be chosen because of his intelligence and ability to handle men and he should have nothing to do with providing food for the men or in any way handling their finances. An accurate timekeeper should be provided where gangs are large. Section foremen, of course, keep their own time, and very particular attention should be given to see that their time is accurately kept, that the men be given all the time they work, and if overtime, they should be told just how much they have made. They should also be told before each payday how much money is coming to them so that there will be no misunderstanding or wrangling about short pay when the pay car comes along.

In working men, the best results can be had by mapping out a day's work and giving them an object to work for, especially in laying rail or handling gravel or stone ballast, when they can see the end of their day's work and the foreman can enthuse them with this end in view. The day will go by pleasantly for them and they will try to accomplish the work outlined with both vim and vigor.

I have also found it very conducive to good results to let the men have a few minutes' rest in the middle of the forenoon and afternoon, perhaps by cutting the noon hour in half and taking the time thus saved for those periods. They should be provided with good living quarters, either in well ventilated and properly heated box cars or in boarding houses, and they should always be required to keep these quarters in a clean and sanitary condition. Plenty of good water should be within easy reach of the camp and a plentiful supply should be carried to them while at work. They should be required to eat good wholesome food of their own liking, which can best be furnished by a labor or commissary agent who, while not necessarily furnishing all the labor, should furnish most of the food the men eat. Their food is different in many ways from that which can be bought at a village or city store, and an agent who is under bonds to the company to properly care for and correctly charge the men for the goods furnished them will prove more satisfactory. The company deducts a certain amount from the laborer's pay for this agent and in this way the men are not subject to exorbitant charges and are not imposed upon by the so-called padrones who are permitted to charge without restriction.

To provide the men with good tools kept in first-class shape should be the constant aim of employers, and care should be used to keep men from getting killed or injured, as nothing tends to demoralize a gang of men more than one of their number being injured while at work. Also the habit, which fortunately is not so common as it used to be, of men in other departments calling the foreigners names and otherwise belittling them should be most strenuously discouraged.

While it may be said that with many men these measures need not be brought to bear, it is safe to say that from the standpoint of humanity, the gratification of having a contented lot of men as well as the result accomplished and the returns given to the employer will well repay a trial.

### ATTRACTING AND HOLDING LABORERS IN RAILROAD SERVICE.

By JOHN S. THOMPSON,

Assistant Supervisor, Philadelphia & Reading, Philadelphia, Pa.

The subject of means for attracting and holding laborers in railroad service is one that always gives considerable trouble and difficulty. The hardest feature of the subject is "attracting." Local conditions affect this considerably and play a large part in finally getting the laborers. For example, take a territory that is wholly within or adjacent to some large city of 1,000,000 inhabitants or upwards where there are always several large competing railroads and many manufacturing concerns and contractors. While the railroads usually pay the same wages, the manufacturers and contractors nearly always pay from two to five cents more per hour, and an employer of labor has to depend upon his men old in service to bring the "green" ones to him for employment. Then, it is up to him to hold them.

The ability to hold men depends very largely upon the "personal equation" of the foreman. If he will only take the trouble to become acquainted with his men, endeavor to help them in every way possible and be pleasant to them, showing them in this manner that the "boss" has a personal interest in them, it becomes an easy matter to show a laborer that 18 cents per hour with the railroad is better than 25 cents with the contractor, for a contractor does not pay his men for "rainy" hours. The foreman should urge the men to get as much education as possible, showing them the advantages of an education, and recommend some night school or teacher to them so that they could get required education to fit them for sub-foremen or foremen. He can also point out to them that there are other positions on the railroad outside of their own department for which they could qualify. The promotion of a laborer travels very quickly among the men and is a big benefit to the employer, not only in holding the men but also in attracting others to the service.

A policy in accordance with the above that will give good results is to give definite instructions as to the work to be done, then see that they are carried out. Have a cheery greeting or a pleasant word, not only for the foremen, but also for the men. When a reprimand is necessary, give it emphatically; forget it, and resume the friendly relations. Give them a friendly wave of the hand from the rear end of passing trains; the men are being noticed by the "boss" and like it.

By adopting such a method it will be found that the men work harder and better results are shown; they work with you and not against you; they are pleasant, and a pleasant, happy man always accomplishes more than a "grouch," and they stick.

A good scheme to attract and hold laborers is the "sliding scale" method in which the laborer entering the service is given the lowest rate of pay per hour and then increased at the rate of one cent per hour at the end of each year for a period of five years. From the laborer's point of view, this will appeal to him, for he is sure of earning more each year.

From the railroad's standpoint, he will stick and each year he sticks, he becomes more valuable. The scheme scales something like this: First year, \$0.18 per hour (or lowest wages paid); second year, \$0.19 per hour; third year, \$0.20 per hour; fourth year, \$0.21 per hour; fifth year, \$0.22 per hour; sub-foreman, \$0.25 per hour; foreman, salary.

One road starts the "green" laborers at the lowest rate of pay and gives them an increase based on their increased efficiency. This is also a good method, but it has the disadvantage of causing jealousy among the men.

#### PERMANENT EFFICIENCY.

By J. J. MORGAN,

New York Central & Hudson River, Kingston, N. Y.

The permanency of efficient labor has a marked effect on the results obtained, not alone in track labor, but in practically every line of railway work. The experienced, efficient laborer is, in reality, one of the railroad's most profitable assets, and his services should be retained permanently. Extra gang laborers are, naturally, a mixed class, but in their ranks can often be found painstaking, efficient men possessing all the requisites of the model trackman, and men whose employment should be of a more lasting nature. The placing of such laborers in permanent section gangs whenever the opportunity presents itself goes a great ways toward establishing a permanent working force. Oftentimes these "finds" are accustomed to boarding in the cars, laborers' houses, etc., provided by the railroads, and in order to insure the permanency of their employment when transferred to a permanent location, it is not a very difficult matter to induce them to move their families to the new location, thereby practically eliminating any possibility of their desiring a change.

The furnishing of sanitary accommodations has a powerful influence, as it attracts the "knowing" class of labor, while the more common and undesirable class are, as a rule, not very particular in regard to the accommodations meted out to them. Where first class accommodations are provided, it is not necessary to beg the men to return to that locality the next season, the conditions themselves being sufficiently inviting.

The question of supervision plays a conspicuous "role" in this drama of permanency. Right treatment is one of the main points governing the location where the track laborer seeks employment. A pleasing atmosphere in which to work aids wonderfully in the accomplishment of permanent efficiency. The advancement of a laborer whenever possible to the position of foreman or assistant foreman has a tendency to incite new hope and ambition in the trackman, and coaches him on to efficiency and perseverance in his work with the inward intention of one day being granted a promotion on the real merit of his endeavors. We can easily distinguish the efficient from the inefficient, and in view of this fact the foremen should use tact in placing the experienced men at work which requires experience and efficiency. While increasing their efficiency and stimulating their confidence to shoulder work which demands responsibility, this also does away with any cause for their dissatisfaction on account of being placed at undesirable work which could as well be taken care of by the "green" laborers.

Where different rates are allowed, the efficient men should certainly receive the larger benefit, and the higher rates should be based solely on efficiency and length of service. When the forces are gradually reduced at the close of the season, discretion should be used in holding the efficient men as long as the authority holds out. The question at hand is one of far-reaching consequence, the solving of which necessitates bringing into play many small and seemingly unimportant points, of which those mentioned above are but a small percentage. Nevertheless, in this connection "the little things surely count."

AUSTRALIAN NORTHERN TERRITORY RAILWAYS.—Surveyors in the employment of the Australian government have now completed the survey of 337 miles of railway in the northern territory. The proposed line will go in a southerly direction from Pine Creek to the Katherine river.

#### DON'TS FOR BRIDGE FOREMEN.

Fifty don'ts for bridge foremen are given in a recent issue of the *Rock Island Employee's Magazine*. A few of the more important ones which are applicable to all roads and which are sometimes overlooked, are as follows:

Don't handle heavy girders with jacks when it can be done at half the cost with steam derricks.

Don't start a piece of work until you have all the material on the ground.

Don't use new material where second-hand will answer the purpose if it can be obtained.

Don't break track without force enough to handle the work.

Don't size caps on pile trestle bridges.

Don't handle and roll timber around unnecessarily.

Don't put in frail or light cribbing around washouts.

Don't attempt a piece of work until you understand the plan and have decided on a method of handling the work. Then carry it to completion along those lines.

Don't figure that you will need no protection for a small piece of work on straight track, even with no trains due for a time ample to complete the work; it is the unexpected that causes accidents.

Don't neglect cleaning up around bridges and structures after the work has been completed. Pile up or ship all usable material to the next job and burn all scrap; it is a part of good house-keeping.

#### RAISING THE RELOCATED PANAMA RAILROAD.

The sliding on the fills across the bottoms of the Brazos and Quebrancha rivers on the relocated line of the Panama Railroad was so serious during the course of the work that in raising the fills to a height of 60 to 70 ft. an average of about 1,660,000 cu. yds. of material per mile was required. Up to the time of opening this line in February, 1912, the embankment had been raised only to an elevation 3 ft. below grade. Since the line has been in service the settling of the fill has lowered the track from 1 to 2 ft., so that it has been necessary to raise these fills about 5 ft. The bottoms appear to be holding satisfactorily and the rise of the water in the lake alongside has not seriously affected the material. The completed fills are being made 40 ft. wide at the top and the slope is usually about one to four. A little over 100,000 cu. yds. of material, which will be required for raising these fills, is being supplied by steam shovel excavation from a borrow pit located at a convenient point.

#### REPAIRING WOODEN TANKS WITH CONCRETE.

Where the bottom of a tank is decayed to such an extent as to make it impossible to draw the staves sufficiently tight to prevent leaks, it has been repaired in a number of instances on the Baltimore & Ohio by placing a mixture of 1:3:5 concrete on the inside floor of the tank. This concrete is placed from 4 in. to 6 in. thick, depending on the condition of the staves or the chime at the bottom of the tank. New hoops are then placed on the bottom of the tank and are drawn up tight. In every case where this method has been used the leaks have been overcome, and it has been possible to maintain tanks for several years that would have been rebuilt at once under former methods. When making such repairs, the condition of the joists on which the bottom of the tank rests is inspected at the same time, and if in bad shape, they are renewed. Several tanks are still in service on which this method of repairing has been used for 8 to 10 years. We are indebted to George W. Andrews, inspector of maintenance for the above information.



# MAINTENANCE OF WAY MASTER PAINTERS' ASS'N.

Abstract of Papers Presented at Tenth Annual Convention  
Held on Tuesday-Thursday of This Week at Louisville, Ky.

The tenth annual convention of the Maintenance of Way Master Painters' Association was held on Tuesday, Wednesday, and Thursday of this week at the Hotel Henry Watterson, Louisville, Ky. This convention compared favorably in attendance and interest with previous meetings. The officers for the past year were: President, George Heintz, P. & L. E., Carrick, Pa.; First Vice-President, C. H. Plummer, C. R. I. & P., Topeka, Kan.; Second Vice-President, Charles Ettinger, I. C., Chicago, Ill.; Secretary-Treasurer, William G. Wilson, Middletown, N. Y.

The principal papers presented at this meeting are given in abstract below.

## DIFFICULTIES AND DEFICIENCIES IN RAILWAY BRIDGE PAINTING.

By WM. G. WILSON

Paint and paint materials never were better made than they are to-day. However, while this is true, conditions are changing, and every year adds some new condition or difficulty for the painter. The object of this paper is to discuss some of these conditions, such as brine drippings from refrigerator cars, drippings from soft coal cars, coal ashes, cinders, dirt, smoke, sulphurous gases, etc. These conditions have come to stay. We cannot remove them, so we must meet them as best we can. The railway foreman painter is the man on the job. By careful observation he can analyze the conditions and by common-sense methods overcome them to a certain extent. Different surfaces, different climates, different exposure and different conditions of application require different paints and compositions. The question is not what a paint is made of but what it will do. The greatest mistake in railway bridge painting is to use any one particular kind of paint to meet all conditions on all parts of a structure alike, or on all bridges regardless of locations or conditions.

When applied to all parts of a bridge alike, good linseed oil and pigment will give splendid protection to such parts as have sunlight and open-air exposure, but will utterly fade on such parts as have dampness, salt brine, smoke, and acid exposure. A bridge built at a high elevation in dry, open air and sunlight, and of open truss construction, can be easily protected with any good linseed oil paint. All parts of a bridge of riveted plate girders built low over water, swamp or marshy ground and carrying heavy freight traffic on main lines cannot be protected with a pure linseed oil paint. This kind of a structure requires special attention with a special moisture-proof paint. If this bridge is painted with linseed oil paint, the upright parts may be in good condition two, three, or four years after painting; while, under severe conditions, the horizontal parts, tops of cords, floor beams, struts and gusset plates will rust within a few months. Then some one condemns the paint and tries another of the same nature, but probably made by another firm, only to meet the same results, whereas the fault is not with the paint at all, but with the engineer or painter.

The cause of paint failing to protect certain parts of a structure is a difference in exposure. Moisture and oxygen destroy the iron or steel, and they should be kept away. This may be difficult, but it can be done. Paint to protect and not merely to coat over as many contractors do. The railroad painter should look for quality. The contractor makes his profit from quantity. Painting may be the preservation of a structure or its destruction. Every square foot of surface a contractor can avoid cleaning and removing rust from is money in his pocket. It does not matter much to him if the surface is wet or dry. If the inspector is not looking, his men will paint it over. In many instances the inspector is a railroad carpenter, not a painter, and any place that is covered with paint is painted so far as he is concerned. He can understand the quantity of paint put on, but does not understand properly rubbing and working it out.

Another deficiency originates with the practice of allowing carpenters to paint the tops of bridges when laying new bridge ties. The painter will have a standing order to supply the paint to the division general foreman of carpenters, who has orders to paint the tops of all bridges when laying ties. This work is done at all seasons of the year and in all kinds of weather. The carpenters have no proper tools for cleaning the rust from the iron. If the rust is very thick, some of the coarser scales may be scraped off. Snow and ice may be partially removed or there often is a drizzling rain falling. As arrangements have been made to run trains over the other track, the ties must be laid and the top of the bridge must have a heavy slushing of paint, regardless of conditions.

The paint cannot dry or fasten to the iron under such treatment, and serves only to catch dirt, sand, ashes, and cinders. Then when brine from refrigerator cars is sprinkled into it, this makes a salt pad to hold moisture and promote rust. The intent of the order is good, but the outcome could not be worse. The remedy: Leave the application of paint to the painter and allow no paint to be applied to iron or steel except under the most favorable conditions.

We paint to preserve, but we must be very careful or we may paint to destroy, and defeat the very purpose of painting. The electro-chemical reactions in corrosion may be divided into two stages: First, the solution of a small portion of iron, and, second, the oxidation of this iron to ferric hydroxide, or iron rust. The red oxide thus formed is insoluble, and when precipitated leaves the way clear for more iron to enter solution and for the further combination of iron with oxygen. These conditions will continue so long as there is any oxygen, water or iron left. The absence of either water or free oxygen makes corrosion impossible. The rate of corrosion depends among other things on the amount of each of the elements present. The rate of solution and corrosion depends principally on temperature and the character of the water, the galvanic action between the different materials, electrolysis from stray currents, and many other minor influences. Corrosion would be simple if we had only oxygen, water, galvanic action, etc., alone to deal with, for then any good linseed oil and pigment would preserve the structure. Linseed oil is the most admirable vehicle for all paints to be used on wood, on account of being porous to some extent, but it is very susceptible to the destructive influences of these destroyers of paint.

After carefully investigating so far as limited means would allow, I believe that a prepared paint vehicle made of linseed oil reinforced with China wood oil, is a great improvement in waterproofing the paint. I have tried several kinds of paints said to contain China wood oil, and some paint oils said to contain China wood oil, and have found that they will dry quicker with a hardness and non-porosity that will outwear linseed oil under hard exposure. Tests made on bridges by painting parts exposed to the same salt brine or exposure to smoke, engine exhaust and gases, showed that where linseed oil paint lasted well for three to four months linseed and China wood oil paints lasted one year and were in good condition. On a bridge where the floor system was painted with two coats of red lead and two coats of black carbon, salt brine exposure had destroyed the linseed oil paint in 6 months. The same exposure on China wood oil paint stood two years in fairly good condition, and parts of the same floor system painted with a patent moisture-proof paint stood two years in good condition. A mixture of red lead, asphaltum varnish, and extra car varnish, mixed one gallon heavy red lead in linseed oil, to which was added one pint heavy No. 96 liquid gum binder, three-fourths gallon asphaltum varnish, and one-fourth gallon extra car varnish, was applied to the tops of tie plates, floor beams, struts, and brace plates. After

thorough cleaning, this dried in splendid condition, and permitted the application of two heavy coats in one day, under exposure that would destroy straight linseed oil paint before it could dry at all. On parts of this same bridge not subjected to direct moisture and brine exposure black carbon paint lasted well for three to four years.

With a special reinforced linseed oil paint, absorption of moisture can be overcome to such an extent as to allow all parts of the bridge to be protected alike by proper cleaning and touching up each year. On main line tracks under severe exposure all bridges should and must be carefully cleaned and touched up with a heavy moisture-proof reinforced oil paint by a competent man at least once a year. This light expense will save one-half to three-fourths of the present cost of railway bridge painting. When a bridge is in good condition, keep it so. It is the only way to paint to preserve the structure. Ordinarily 75 per cent. of the cost of bridge painting is for cleaning, and in this way 60 per cent. of the cleaning can be eliminated. That means cutting the regular cost of bridge painting in half.

It is commonly agreed that red lead and linseed oil make the best priming coat and filler for bridge painting; but there are exceptions to all rules. I know of large bridges subjected to excessive salt brine drippings, coal dirt, cinders, soft coal, and ashes into which hot and cold water from shifting engines is constantly being dripped. To make a bad matter worse, engines on tracks passing under the bridge subject it to the action of sulphurated hydrogen and sulphuric acid. These agencies quickly destroy red lead and oil which are about the worst materials that can be used in parts of structures subjected to these conditions as in train sheds. The rusting of surfaces subjected to these conditions is greatly accelerated by galvanic action which causes the pitting.

There are cheap, non-drying black Japan elastic roof paints that will protect under these conditions and by carefully cleaning and painting once or twice a year preserve the structure. If a cheap non-drying black Japan roof paint will give better results in these situations, why cannot a paint made of better materials and with the ultimate object of protecting iron under severe conditions, help solve the difficulty? There are several specialties made for this very purpose by eminent chemists and paint makers. Special paints for special purposes will greatly aid in the preservation of structures under severe conditions.

#### THE ADVERTISING VALUE OF RAILROAD PAINTING, DECORATING AND NEATNESS OF APPEARANCE.

By MARTIN KANE,

Master Painter, Delaware & Hudson, Albany, N. Y.

The advertising value of decoration and neatness of railroad properties is founded on the very meaning of the word—it directs attention, it attracts, it causes comment. The most effective appeal to human nature is through the senses; that impression which appeals to the æsthetic taste remains with us, and no stronger appeal can be made than through the sense of sight. Well-kept, neat, and properly decorated railroad properties, resulting from efficient and effective painting, must appeal to the sense of sight, and consequently attract, direct attention, and cause comment. In so doing, it obtains all of the results expected of advertising, and, furthermore, it is, and becomes, a permanent standard and a fundamental form of advertising.

The old adage, "Actions speak louder than words," is especially applicable here, for above and beyond any written or printed decoration of the efficiency of a railroad, the properly kept properties of a road are the absolute realization in one of the road's most important features of its efficiency. The immediate results of proper decorating and neatness of appearance in railroad painting will be found in its benefit to the passenger, to the community in which the railroad properties are placed, and finally to the railroad itself.

The passenger benefits, for there can be no question that neat and wholesome surroundings, when entering upon or completing a journey, do much to relieve the monotony of it, and that neat

and decorative painting of properties along the route of his journey are to the eye surfeited with the sameness of the scene, an immense relief.

The community in which well-kept, neat, and properly decorated railroad properties are located is benefited because of the great effect exercised upon the community itself. Every community has its local pride, and this pride will induce private individuals to endeavor to live up to the general excellent condition in which the road properties are kept.

From the benefits and advantages secured by the passenger and the community, and the consequent advertising, the railroad is aided. The passenger, from the efficient condition of the railway properties, receives his impression of the general efficiency of the road and proves it to his friends, neighbors, and associates. This result is an increase of passenger traffic.

The community benefits by the railway properties because of an attitude of general friendliness toward the road, and will patronize the road in preference to a competing road, from which no such benefit has been derived. This will result in an increase of both freight and passenger traffic. Favorable impressions are gained by industries and manufacturers seeking locations, and may result in their locating along the railway, which will mean increased business for the road.

Nearly all railroads have their standard colors, but the most pleasing colors are harmonious combinations properly applied under the direction of competent master painters. The most valuable advantage of advertising that railroads possess is the painting of signs on freight and passenger depots. This branch of advertising is neglected on many roads, and is a direct loss to the railroad, community, and passengers.

#### CAN CONTRACTING OF RAILROAD PAINTING BE DONE WITH ECONOMY TO THE RAILROADS?

By J. C. WILLIAMS,

Master Painter, Northern Pacific, Minneapolis, Minn.

The following article has been written with the understanding that the larger proportion of the railroads are now paying their men on a flat rate basis. Under existing circumstances, can the painting be done by contract with economy to the company? On regular maintenance work, I will say No; but on improvement work exceeding a labor total of \$300 it can be done, and the results will be more satisfactory than they would be if done with the average regular division crew the railroads now employ, for—let us say—25 cents per hour, which I believe is a fair average of the wages paid by the railway companies for this line of work.

It is not my intention to start a discussion on the subject of employing competent men at the above rate, because we cannot do it, and if we are fortunate enough to have a man or two in the crew that knows his business, we have many more that know nothing, but who still receive the same rate as your man of efficiency.

These conditions alone cause the loss of thousands of dollars to the railroads annually. When one places two men together, one experienced, and one inexperienced, and each receiving the same rate per hour, at the end of the day he has the results of two inexperienced men in the amount of surface covered.

No doubt we all have seen the final results of this. In a short time we see our one-time competent man working for some contractor who has found out that it is just such men that he is obliged to employ in order to make anything in his business.

Consequently, I believe the work that is done by contract is done by more competent men than the company employees, which not only makes a difference in the appearance of work when completed but in durability as well. The cost of the work by contract is about the same as it would be if done by the company's own men.

I believe that it is the general practice of the different railway companies to furnish their own materials. Even though the labor is let by contract, especially where the company has adopted standard formulae in their colors and its own chemists have tested the materials, the railways are taking small chances with

with a contractor using substitutes or adulterations in the paint.

When a contractor employs his own men, and pays them what they are worth to him, he is not working under the handicap that a railroad employer is, but he can expect a man to paint a given amount of surface per day and at the same time do it well. When employing mechanics of this class, he can bid in work and complete it in better shape at a price not to exceed the amount that company forces require, and the company is getting more for the money expended.

#### A NEW DEPARTURE IN RED LEAD.

By A. H. SABIN,

Consulting Chemist, National Lead Company, New York.

For at least 100 years red lead has had a high reputation as a paint, especially to protect iron from rusting, but also, especially in England, as a priming coat on wood. This favorable opinion has not, however, been unanimous; it has been held by some that while it undoubtedly gave excellent results sometimes, in other cases it was not so successful. In explanation of this, it may be said it has long been known that red lead is not commercially, at least, a definite substance; it is commonly made from litharge, which is an oxide of lead, containing less oxygen than red lead. By a process of roasting in contact with air, the litharge takes up another portion of oxygen and is converted into red lead. In all red lead there is often as much as 30 per cent. and commonly not less than 15 per cent. of unchanged litharge.

Litharge is a yellow powder, made by roasting metallic (melted) lead in the air, with frequent stirring; it is naturally coarse and inclined to crystallize; when it is re-roasted to make red lead, each coarser particle does not get oxidized through, but contains a core of unchanged litharge surrounded by a coating of red lead. Obviously the way to avoid this is to have no coarse particles of litharge; this means that the latter should be ground to an impalpable powder before roasting; by this means we may produce red lead of almost any degree of purity we desire. Some 15 years ago the late William Jackson, then city engineer of Boston, told the writer that he had used red lead which had undergone some treatment preliminary to its final roasting, by which it became practically pure red lead, and that this made a paint much superior to ordinary red lead; at the time when he used it, above 20 years ago, he had found it impracticable to secure such red lead in a continuous supply. Recently Samuel Wagner, division engineer on the Philadelphia & Reading, informed me that some ten years ago, being dissatisfied with the paint in use, he had specified red lead to contain not less than 95 per cent. of true red lead. After considerable difficulty, he succeeded in getting such material, and had ever since used it where red lead was desired.

It is well known that in 1906 the American Society for Testing Materials applied 19 different paints to successive sections of the Pennsylvania bridge at Havre de Grace. After seven years' exposure, three paints are officially reported as constituting the first class, in each of which the active pigment is red lead, and in two of them the red lead contains not less than 97 per cent. of true red lead (the exact composition of the third is not known to the writer), thus clearly proving that a high-grade red lead makes an excellent paint not only for priming and body coats but also for the surface. Many people think that red lead does not make a good finishing coat, but evidently it does if it is the right kind of red lead. It is well known that on long exposure to the air red lead paint turns white; this is a superficial action, confined to a very thin layer, which is converted into ordinary white lead or carbonate by the carbonic acid in the air. White lead is such an opaque pigment that a very little of it makes the red surface change color, and this is often, though mistakenly, believed to indicate that the paint is injured. A little chrome green in the finishing coat, making a fine olive green color, or a little lampblack, which inclines it to brown or chocolate, will prevent this; and such a paint is not only pleasing to the eye but

of excellent lasting quality in most places. There are places, like the interior of train sheds, where the air is heavily charged with certain acids which attack lead, where the red lead body may be profitably covered with a good acid-proof paint; but for most places this is neither necessary nor desirable.

If it is conceded, as the evidence seems to prove, that this special high percentage red lead is a better paint, it is important to ask just how does it differ from the ordinary 85 per cent. or painters' red lead. The chemistry of the matter has been explained; but it may be pointed out that in a gallon of mixed red lead paint containing twenty pounds of dry red lead of the ordinary kind, there are about three pounds of litharge. One pound of litharge is enough to make about three gallons of a lead japan drier; so in a gallon of such paint there is enough litharge to make eight or ten gallons of drier. No wonder such paint hardens in the pail. Of course, the litharge is not as active as it is when made into a drier, but it is there, and it is the cause of the bad behavior of the paint. We all know that ordinary red lead paint is very difficult to apply properly; it quickly begins to thicken, and this makes it stiff in working and hard to brush out, and it lies unevenly on the surface; in one place too thick, and in another place much less; and the real protection is that of the areas where it is thin.

Now, a high-grade red lead, containing very little litharge, has little or no action on oil, and brushes out like white lead, making a smooth, uniform film, which gives uniform protection to the surface which it covers. As one result of this, a gallon of such paint will cover from a third to a half more surface than a gallon of the old kind; and as it is easy to apply, the painter can go over a half more square yards in a day's work. Being extremely fine, it makes a paint of good working quality; if necessary, it can be flowed on with a full brush, just as if it were white lead. Coal cars are sometimes painted in this way.

It is only recently that red lead of this quality has been available in considerable quantity; but now the National Lead Company is putting it up in paste form, ground with seven per cent. of oil, and put in steel packages exactly like paste white lead. It is not known that it will keep indefinitely, but I have seen it a year and in some cases a year and a half old, still in good condition; and no argument is needed to persuade a painter that paint which has been ground through a mill is of much better quality than if mixed from a dry pigment by hand. This paste red lead is sold at a price which makes a gallon cost from three to six per cent. more than that which is mixed by hand.

#### TREATMENT OF CONCRETE SURFACES.

By GEORGE WHIGELT.

To attempt the painting of concrete it is necessary to know something about the origin of the effervescent salts and alkalies, which are the destructive agents of paint materials applied over them. Those salts are commonly known as saltpetre, and are considered by chemists to be nitrates of sodium, carbonates of lime, etc., but as a matter of fact the real chemical nature of such exudations has not been established, and thereby lies the difficulty of a successful treatment. Whatever those salts may be, they sure belong to the alkalies which are the most destructive agents of paint materials.

All such salts are only destructive when active, and they are only active in connection with water. All new buildings or exposed surfaces contain moisture, and therefore we must attempt to overcome their destructive action by preventing moisture. Another matter to be considered in successfully treating such surfaces is to take into consideration the condition of the surroundings, possible percolation of moisture from the ground or outside, also the weather and climatic conditions. Another item of importance is vibration, which in itself is very destructive. A structure subject to moisture and vibration will show deterioration within a short time. Small particles of water enter into the pores of the surface, and continuous vibration will cause those particles of water to expand and explode. Such continuous

explosions, no matter how minute, will cause particles of concrete, brick or stone to break off and the structure is slowly but surely going toward its destruction. Sudden frosts also have the same action on exposed surfaces and will cause the checking off.

In considering the proper treatment of concrete to prevent the so-called saltpetre from destroying surface coating, it must be remembered that those salts, besides being alkalies, seem to have an acid reaction and are therefore much more difficult to combat than plain alkalies. In fact, I consider those salts a combination of acids and alkalies, which combination results in the formation of salts in crystal form.

The treatment for interior work is somewhat different from exterior work in that the subsequent coatings are generally of a different nature. For interior work, very often water colors or flat oil paints are used, whereas for exterior work water colors are entirely omitted and the oil paints used are of a different nature from the inside coatings.

For new exterior work, no matter if the surface is of brick, stone, concrete, or a mixed construction, the first thing to be done is to thoroughly clean the surface from dirt, dust, grime, etc. Clear drying weather is always necessary for such work. After cleaning the surface a neutralizing agent must be applied to change the nature of the salts contained in the walls into a neutral chemical. For such purposes a number of neutralizers

## SCALE TEST CAR OF THE UNITED STATES BUREAU OF STANDARDS.

Ever since its inception the Bureau of Standards of the Department of Commerce has spent a great deal of time in studying the weights, measures and scales used in this country. The appropriations made last winter by Congress included an item for the study and testing of the railroad track scales of the country, and the bureau has just put into service its Test Weight Car No. 1. The equipment of this car, including the large standard weights, was designed and constructed by A. H. Emery, of Stamford, Conn., to meet the requirements given by L. A. Fischer, chief of the division of weights and measures of the Bureau of Standards, and C. A. Briggs, of the bureau, who has charge of the car.

The general idea of the apparatus is, briefly, a car equipped with a crane which can be projected out of one end of the car and which is equipped with a trolley and hoist. The car carries a motor-driven truck and 100,000 lbs. of standard weights. The crane, bridge, trolley and hoist and the truck are all operated from a gasoline motor and electric generator set, also carried in the car.

When in use the car is placed with the open end near the scale to be tested, the crane bridge is projected, the truck



Scale Test Car of U. S. Bureau of Standards.

are used. Fuming acids as well as certain salts can be used for this purpose. The fuming acids have the disadvantage of being dangerous and difficult to handle, and, as a rule, act on the subsequent coatings, resulting in an unsatisfactory job. Salts, such as oxalic acids have a bleaching and color destroying tendency, although oxalic is one of the strongest neutralizers, and if properly treated its bleaching effects can be overcome. Acetic acid acts only temporarily. White vitriol is well to be recommended, but it is not always strong enough in its action. The application of kerosene is sometimes of advantage, but not commendable when paint is to be applied as a final finish.

To be effective, all neutralizers, of whatever nature, must be first of all penetrating to go to the seat of the trouble. The first coats should also be of a penetrating nature, as a heavy layer of paint will only hide the trouble for a limited time and is more to be avoided than a poor finishing material itself.

Special prepared China wood oil, boiled linseed oil applied hot, greatly reduced Spar varnish, and where suitable benzole thinned liquids are the most effective materials for the purpose. Coloring matters should be left out of the first coating entirely. To finish up it is advisable to use a pure linseed oil paint made from pure lead with 20 to 30 per cent. of white zinc added. Instead of using an oil destroying drier of otherwise quality, I advise the use of a good varnish as a drying agent.

is lifted out of the car, placed on the rails and run onto the scale. Readings are taken and the truck is run back under the crane, where as many of the standard weights as may be desired are placed on it and it is again run out onto the scale and readings taken. The two illustrations show the car and also a closer view of the truck with its full complement of 90,000 lbs. of standard weights.

The car is of a standard heavy type with steel underframe, roof and doors and steel braced sides. One end is closed and heavily steel-reinforced, and the other end has two large doors as shown. A partition extends across the car about 10 ft. from its inner end forming a room which contains a 10 k. w. Sturtevant generator set, providing the power for operating the car and lighting it, a Davenport bed, water tank, wash bowl and toilet, stove, chair and folding table. The generator radiator and fan are carried in the other part of the car, as is also the storage battery, which is charged from the generator set and is used for lighting the car when the generator is not running.

A frame for carrying the crane bridge is built into the car at the open end. Two H-beams and two channels from the bottom and side members respectively, and two other H-beams bent to conform to the shape of the roof form the top member to which are fastened two castings which carry the

wheels on which the crane bridge runs. The need of this heavy construction will be apparent when it is considered that under certain circumstances the load on these two wheels may be 20,000 lbs.

At the partition there are two vertical 6 in. ship channels which carry castings and wheels for supporting that end of the crane bridge, and for holding it down when the overhanging load is great enough to overbalance its weight. The construction and general arrangement of the bridge, trolley and hoist are well shown in the illustrations. The bridge is projected by means of a motor driven screw fixed to the rear end of the car and a nut fastened to the side of the crane. The hoist is of 5 ton capacity, has a 5 horsepower motor and is transversed by a 2½ horsepower motor.



Truck, Standard Weights and Crane of Standard Scale Test Car.

The uprights at the partition are stayed to the rear end of the car by long rods, and the crane bridge can be bolted to these uprights for shipment. The trolley can also be bolted to the bridge. The truck is provided with a 5 horsepower motor with worm gearing, has a capacity of 50 tons, and is connected to the generator by the cable shown. This truck weighs slightly over 5,000 lbs.

There are eight 10,000 lb. weights, four 2,500 lb. weights, of cast iron, machined all over, painted and adjusted to exact weight. The probable error of the whole 90,000 lbs. is  $\pm 24$  lbs. and the average probable error of any one 10,000 lb. weight is  $\pm 0.08$  lb. Aside from this 90,000 lbs. of standard weights the car also carries 10,000 lbs. of 50 lb. weights in three boxes which are equipped with special handling apparatus so they can be easily removed from the car to a wagon and run about any town where the car may be.

**NEW PRUSSIAN TUNNEL.**—Some very interesting operations are in progress in connection with the building of the Distelrasen tunnel, on a deviation of the Prussian State railways, near Elm, which, when completed, will have a length of about two miles, and consequently be the second longest railway tunnel in Germany. Owing to the nature of the rock, great difficulties were met from the start, and work could only be proceeded with with the utmost precaution. It is expected that the tunnel will be finished by March, 1914. The total cost of the deviation, which is to be opened on May 1, 1914, will be \$3,750,000 in round figures, of which not less than \$2,375,000 will be represented by the cost of the tunnel.

## AN UNUSUAL FOUNDATION FAILURE.

The very unusual failure of the foundation of the new Canadian-Pacific elevator at Transcona, near Winnipeg, has created a great deal of interest among engineers, the failure being due to the crushing of the foundation material under one side of the structure, permitting it to settle to the angle shown in the photographs. This movement was gradual and consumed about



Breaking of Ground Surface on Upper Side of Elevation.

24 hours. The early stages of the construction of this elevator were described in the *Railway Age Gazette* of April 18, 1913, page 889.

This elevator was built in 1912 and consisted of a working house and 65 circular bins of 14 ft. 4 in. inside diameter and 9 ft. high, of reinforced concrete. The working house was built 10 ft.



Looking Toward Inclined Bin After Roof Had Slid Off.

south of the bin house and entirely separate from it so that it was not damaged by the failure of the bins.

The underlying soil is a soft clay with rock 45 to 50 ft. below the surface. The bin house was carried on a reinforced concrete slab 77 ft. by 195 ft. about 12 ft. below the surface of the ground. Load tests made at the time of construction indicated that the soil could safely carry four to five tons per sq. ft. How-

ever, the maximum loaded weight of the structure at the time of failure averaged slightly over  $2\frac{1}{2}$  tons per sq. ft.

On Saturday, October 18, between 11 and 12 o'clock in the morning, when the elevator was practically full, a slight movement was noticed on the bridges connecting the working house and the bin house. By one o'clock in the afternoon the bin house had settled about one ft. and the ground for a distance of about 25 to 30 ft. on three sides of the bin house had risen four or five feet. The building continued to settle until noon of the following day, tipping to a final angle of 28 degs. from the vertical. In its final position the base at the east side of the structure is



View of Inclined Bin and Undamaged Headhouse.

about 5 ft. above the former level, while the west is about 30 ft. below.

At the time of the accident about 855,000 bu. of wheat were in the bins. To recover this grain a temporary conveyor belt was built on the upheaved ground along the west side of the structure underneath the overhanging bins. The side of the bins was then broken open, and the grain allowed to run out onto the belt which conveyed it to a chute delivering through a basement window of the handling house into one of the receiving legs which loaded it onto cars. As the grain was emptied from one bin, men went inside and opened the walls of the next. In this way the grain was removed from the top part of the different tanks. The angle of the bins from the vertical was



Closer View of Under Side of Bins.

practically the angle of repose of the wheat, and it was possible to remove a large proportion of the grain in this way.

The fact that the foundation mattress of the annex had settled below the foundation of the working house prohibited any attempt at excavation between the two houses. Therefore, while the wheat in the upper parts of the bins was being drawn off, excavation was made at the north end of the annex so as to allow access to one of the lower tunnel belts. The leveling up of this tunnel belt was completed ahead of the excavation so that a temporary elevating leg was erected to lift the grain from

the tunnel belt and deliver onto the temporary belt at the side of the house.

In the design of this storage house longitudinal walls on the mattress supported the bin bottoms. Four of these tunnels so formed by the walls were used for basement conveyor belts. The other tunnels between the belt tunnels had transverse walls under the contacts of the bins, which were undoubtedly responsible for the fact that no weakness appears to have developed in the basement. These tunnel walls were pierced at frequent intervals by openings allowing access from one tunnel to another. In drawing off the grain from the bins above the conveyor belt, which was being used to recover the grain, troughs or sluices allowed the grain to flow from the bottoms of the upper bins onto the belt, in this way affording a very economical means of recovering.

The use of the elevator cannot be resumed until the bins have either been reconstructed or moved back into their normal condition. Final procedure has not yet been fully decided upon. We are indebted to Frank Lee, principal assistant engineer, Canadian Pacific, for the above information and photographs.

### A SCOOP CAR FOR REMOVING SLIDES.

A scoop car has recently been designed and built by the Norfolk & Western for use in removing from the track earth and rock coming in from slides or dropping from the roof of a tunnel. This car is designed within the standard clearance limits and can be transported over the road without removing the roof or any of the crane rigging.

The car consists essentially of a 40-ton wooden flat car with a heavy wooden roof supported on steel framework. On the front end of the car is mounted a 25-ton revolving jib crane, adapted to handle a 10 cu. yd. scoop, which is pushed on the track in front of the car. A Lidgerwood hoisting engine, specially designed for this purpose, is located on the flat car. It has a lifting capacity of 17,000 lbs. at a speed of 30 ft. per minute and the swinging gear has a rope pull of 5,000 lbs. The engine is provided with one cable adapted to raise the scoop and another cable for revolving the jib crane. The hoist is provided with a 14-in. friction drum and has a double-acting brake. Regular vertical boilers 46 in. in diameter and 96 in. high are provided. The standard Lidgerwood swinging gear is installed. The car is further provided with a suitable water tank and coal space and is reinforced to provide the necessary strength for the severe duty imposed on the car.

The scoop is built of  $\frac{1}{2}$ -in. steel plates reinforced with angle irons and bars, and is provided with teeth at the front end to aid in entering a mass of material on the track. The scoop proper is carried in a frame or cradle which is composed of heavy steel bars.

A heavy 12 in. by 12 in. bumping timber suitably braced and supported is secured to the front end of the flat car near the rail. The frame or cradle for the scoop is hinged to this brace by a transverse pintle which allows play lengthwise of the car so there will be no binding when the cradle wears back into the wooden bumping timber. When in operation the front end of the cradle rests on the track, being supported by suitable wearing strips. The scoop, resting in this frame or cradle, may be hinged along either side, so that by raising the opposite side the entire contents of the scoop may be dumped along the side of the track.

The operation of the outfit is as follows: A locomotive is coupled behind the scoop car, and the front end of the cradle with the scoop in it is lowered so that it rides on the rail. The scoop is then pushed into the mass of material to be removed from the track and is filled with material. The clevises of the single-tree on the jib crane being attached to the front extremity of the cradle, the front end of this cradle is now raised a few inches above the rail, the scoop is withdrawn from the

mass of material and it is transported in this manner to a convenient place for dumping. The front end is then let down, a wedge-shaped timber being placed on the ends of the cross ties to support the cradle. The clevises are then removed from the front end of the cradle and are attached to suitable points on one side of the scoop. By raising this side of the scoop, the scoop being hinged to the opposite side of the cradle, the material in the scoop is dumped along the side of the track, the jib crane swinging around to follow the movement of the side of the scoop at the same time. The scoop is then returned to its proper position in the cradle and the outfit is ready for another trip. Rail clamps are provided for use where the load in the scoop is sufficient to overturn the front end of the car, but in ordinary service these are not needed.

The amount of material on the track in a slide usually runs somewhere from 100 cu. yds. to 400 cu. yds., and is composed of a mixture of earth and stone, probably about two-thirds earth and one-third stone. The scoop is used on an average of about twice a year on a division. One locomotive is used in driving the scoop into the bank of material and the speed when striking is from 6 to 10 miles per hour. This ordinarily fills the scoop

car is a little light for the severe duty that is imposed upon it by this outfit.

There is also in use on this road another scoop car which consists of a plain scoop which is pushed along in front of a flat car into the bank of dirt. When filled this scoop is raised off the track and transported as in the latest arrangement, but, instead of dumping, the old scoop is simply set back upon the track, and as the sides are hinged, one or both of them are let down and the material shoveled off. This, however, requires 12 men and takes more time in addition to a trip.

Patents on both these outfits have been granted to L. E. Johnson, president of the Norfolk & Western, under whose direction they were designed.

**STORING EQUIPMENT.**—As the Panama Canal is nearing completion a large amount of construction equipment is being released for storage pending its disposal. A committee appointed to consider plans for storing this equipment has recommended that if it is impossible to procure sheltered storage space for steam shovels, locomotives, cranes, pile drivers and similar equipment, the arrangement of tracks in the Gamboa yard would be the



Scoop Car of the Norfolk & Western.

about two-thirds full and removes about 7 cu. yds. of material. The distance necessary to transport the material before dumping varies, of course, with the locality. In some instances it might be a few hundred feet while in others a mile or more.

It is customary to use seven men with the scoop car outfit, in addition to the regular train crew. One of these men acts as scoop car engineer, one is stationed on the front end of the scoop car to look after the filling and dumping, and the other five men are laborers who assist in cleaning the track and cleaning out the scoop, the material handled being sometimes of so viscous a nature that it will not readily dump from the scoop.

When transporting the empty scoop for a long distance the scoop and cradle are fastened together and the entire outfit may then be raised by the crane and loaded on an adjacent flat car. The two cars are then coupled together for ordinary train service. Small chains have also been provided to prevent the swinging of the boom in train service. The heavy roof over the outfit has been provided for the protection of the operator when engaged in tunnel work.

Two of these cars have been built and placed in service by the Norfolk & Western. These have been mounted on standard 40-ton wooden flat cars. If, however, more are built they will probably be placed on new 50-ton steel flat cars, as the wooden

most suitable location for this storage, especially in view of the facilities for readily switching out any particular piece. There is about 5,000 track ft. of storage space in the Gamboa yard, about 36,000 ft. of track in the yard and approaches to the relocation dumps between Gamboa Cabin and dump No. 7, and about 27,000 ft. on the dumps proper. It is believed that track can be provided at these points for all rolling stock as fast as it is retired from service.

**PROPOSED CAUCASUS TUNNEL.**—The administration of the Russian railways is seriously occupied with the project of a tunnel of gigantic proportions through the Caucasus mountains. This tunnel would have a length of 16 miles, and it has been already the object of a conference between Russian and foreign engineers. The geological structure of the mountain does not present any great obstacles. During the borings of the galleries no such difficulties will be encountered as during the borings of the Simplon tunnel. The temperature can be maintained at about 77 deg. Fahr. The elevation of the tunnel being between 4300 and 4650 feet, there is no danger of encountering subterranean water courses. The work will take about eight years. This undertaking would insure a direct connection between Vladikavkees and Tiflis.

## HEAVY MAINTENANCE WORK ON AN INDIAN RAILWAY.

The organization of the Royal Engineers, a branch of the British military force, includes two companies which are assigned to railway maintenance work. Although the standards of construction on Indian railways where these companies are engaged differ considerably from those familiar to American maintenance men, the following description of the relaying of a section of track  $4\frac{1}{2}$  miles long, as described in



Dismantling the Old Road.

the *Royal Engineers' Journal* for October, 1913, will doubtless be of interest.

The old track consisted of 75-lb. rails laid in 20-lb. chairs on wooden ties which had been in service about 10 years. It was found that these ties had been so badly eaten by white ants that in relaying the rail it was necessary also to replace all the ties. The 20-lb. chairs were not satisfactory for the heavy power in use on this line so 40-lb. chairs were laid on the new line. Deodar ties were spaced 2 ft. 2 in. center to center at the joints and 2 ft. 6½ in. between intermediate ties. This spacing is somewhat closer than standard in order to form a more rigid support for the heavy engines. For one short section where the maximum grade is four per cent., 100-lb. rails were used, although the remainder of the line was relaid with 75-lb. rails.

The forces employed for this work included 100 men of the twenty-sixth company and from 50 to 60 native coolies. Owing to the scarcity of men it was impossible to carry out all of the operations on one day so the system was adopted of removing the ballast from the old track and spiking on enough chairs in one day to last for two or three days' relaying. There was a speed restriction of 15 miles per hour over the whole section so that there was no danger in skeletoning one-half to one mile of track at a time. It was arranged to run most of the traffic at night so that the work could be carried on without interruption for eight hours, from 9 a. m. to 5 p. m., if necessary. The  $4\frac{1}{2}$  mile section was completed in 20 days, of which 12 days were occupied in relaying and eight in skeletoning the track, collecting material, etc. The company remained an additional five days to give the line a final raise and packing.

In removing the ballast to the level of the bottom of the ties, each "sapper," as the privates and non-commissioned

officers are called, averaged two rail lengths per day. The coolie labor barely averaged one length per man per day. The ballast consisted of river gravel mixed with sand which was tightly bound together, making it difficult to handle. The position of the chair on the tie was found by the use of a templet and marked. The position of the spike holes was then found by placing a chair in position and marking the tie through the holes, after which the holes were bored and the chairs spiked on. One sapper bored 100 ties with three holes in each tie and one sapper spiked 150 chairs with three spikes in each chair in a day. In putting in and taking out ties, three men were used per tie.

After the old rails had been turned out of the chairs by three men with bars, they were lifted and thrown clear by 12 men. Such a party was able to throw out one-half mile of rails in from ½ to ¾ hour. The placing of the new rails in the chairs was the operation which limited the speed of the day's work. The chairs supplied were very tight between the jaws and the delay was experienced in getting the rails into all of the 12 chairs at once. The chairs spiked to the ties were roughly spaced and lined by a 100 ft. cord, the rail was then laid on the ties inside the chairs and all chairs were lined to it by pulling in the ties. The rail was then lifted onto the chairs and forced into each one separately by three men, two of whom were working with bars. No difficulty was experienced in putting in the opposite rail, as only the two end chairs were spiked before laying the rail, the remaining ones being slipped into their places afterwards. To secure the proper tie spacing the interval center to center of ties was marked off on the rail and the corresponding position then squared off on the opposite rail. In



Turning the Rail Over in the Chairs.

gaging the opposite rail, three men worked in a party. The fastest time made for gaging, boring and full spiking was one rail length in ½ hour. The average was about ¾ hour.

On days when the new rail was to be laid, two fish bolts were removed from each joint before the arrival of the last train in the morning and the two remaining bolts were first eased and then tightened again to pass the train. The organization of the 100 men for the first half hour of the day's work was as follows: 12 men removing the remaining fish



Gaging Party.



Straightening the New Road.



bolts, 2 knocking out keys, 6 collecting nuts, fish bolts, keys, etc., 3 turning over rails, 12 lifting out rails, 20 lifting and throwing out ties, 12 cleaning and leveling the roadbed, 22 laying new ties, 6 alining and roughly spacing ties, and 5 collecting chairs, pins, keys, etc. Usually a half hour was sufficient for the dismantling and for the rest of the day the men were organized as follows: 14 men laying rails in chairs, 56 laying and spacing ties, 2 placing chairs in position, 12 laying opposite rail on two chairs, 2 distributing spikes and keys, 12 linking up fish plates, and 2 marking tie spacing on rail.

## REPAIRING BALLAST CARS.

By KEYSER.

The conditions under which the ballasting of railways is done vary to a considerable extent, depending on whether the line is under construction or is being rebuilt or repaired, the density of traffic, etc., but in too many cases little or no serious attention is given to the matter of repairing the cars used for such work. Ballast cars are very commonly treated as of small importance, and repairs which are really necessary are often allowed to pass with little or no attention, the fact that a broken or burned off journal or a trailing brake beam on such cars can cause just as much delay to traffic as a similar condition on any other class of car seeming to be overlooked.

When ballasting has to be done there seems to be objection on the part of some railway officers to putting on more than one or two extra car repairers to take care of the work of ballast car repairs. When a ballast pit is so located in relation to an established terminal that the repair work can be handled by the regular car repair staff, this policy, while it is to be deplored, is not so serious as in an isolated district, as the work can generally be done by overtime if necessary. But when the point of ballast supply is on an isolated branch or so located on a division as to necessitate the repair work being handled at or near the pit, it often becomes very serious. It is impossible for one or two car repairers to properly look after repairs to any great number of cars and the policy of letting bad order cars accumulate until there are enough to require a special train to move them to a terminal is a poor one, as is that of allowing the repairs to be entirely neglected.

In a case which came under the writer's notice, the work was handled with much satisfaction to all the departments concerned, and as there was not a single case of ballast car failure causing a delay to traffic during the three months the work was in progress, it was considered that the method followed was justified. The ballast pit was located a short distance off the main line. The track between the pit and the main line was little used and in such poor condition that the heavier locomotives could not be used, so that it was necessary to either double head on 28 car trains or haul only 14 cars in a train. There were two shovels in use and the haul varied in length from about 10 to 70 miles. The repair gang consisted of a foreman who also acted as inspector, a man who looked after air brake repairs and the keeping of the journal boxes well packed, two repair men and two helpers. All classes of repairs were handled except such work as repairing broken sills, and as there was only one case of this kind, the car was removed from service and left idle.

In the work of this nature there is often too little attention given to the matter of quarters for the men. In this instance there was of course, the regular assignment of boarding cars for the track men, etc., and a special car was carefully fitted up with bunks, mattresses, etc., for the exclusive use of the car and locomotive repair men, as much as possible of the locomotive repairs also being made at the pit. The meals were served with those of all the other men in the car provided for the purpose.

As soon as a train returned from a trip it was inspected and any bad order cars placed on a track provided for repair work. This track was located out of the way of the shovels on ground over which they had previously passed and the gravel made a good dry surface for the work. Adjacent to this track was a shorter one on which cars requiring wheels changed were placed. When inspecting a train, the foreman made a note of any cars which required only trivial repairs, such as brake wheels, renewal of nuts, etc., and later assigned a man to do this work in the train, thus avoiding much of the switching which would have been necessary had the cars been moved to the repair track. The man in charge of the ballast trains was notified twice a day as to what cars were again ready for service, and these were generally switched out and replaced in the trains at noon and in the evening. The man in charge of the oiling made it a point to examine the journals of each car once a day and hot boxes, one of the greatest bugbears of ballast train work, were almost unknown.

One of the most important considerations in work of this kind is that of supplies. The writer has seen ballast pits at which a material car was furnished containing a mass of bolts, brasses, wedges, etc., thrown in indiscriminately and causing no end of trouble and much wasted time in finding material when wanted. In this case two box cars were provided, one for general stores and one for oil. One side of each was boarded up and a good lock was applied to the door on the other side, with keys for the mechanical men only. The store car was arranged inside with boxes and pigeon holes and a good supply of each necessary size of bolt, etc., furnished. It is a mistake, in fitting up store cars, to provide material that is not likely to be used; it is in the way and takes up space which may be needed for such important material as draft timber bolts, brasses, etc. The oil car had racks for barrels and bins for waste and each man was held personally responsible for the neat and cleanly appearance of both cars. A daily inspection of the material on hand was made and the nearest terminal telegraphed for additions a sufficient time in advance to prevent the supply becoming entirely exhausted. Draft timber bolts, journal bearings, and oil and waste are among the most important items, and a good supply should always be kept on hand. Wheels were furnished a carload at a time, and were unloaded next to the wheel changing track, while three complete couplers were kept available at all times.

The man in charge of the car repair work at this ballast pit had had experience in a number of other pits and knew the conditions which generally obtain. In consequence he saw to it that his supply cars were furnished in an efficient manner and organized his staff along lines which he had worked out from his experience. The locomotive work was handled separately from the car repairs. The results proved most satisfactory, there being no failures of ballast cars on the road during the entire time that the work was in progress and a minimum of hot boxes. Enginemen knew, in starting out with a train, that the slack in the brakes was properly adjusted and that they did not need to take chances in making stops. The conditions were particularly appreciated by the trainmaster and other operating officers and the trainmen, when they learned that real efforts were being made to keep the car equipment in good shape, went out of their way to help in the work instead of using it as roughly as possible, as is more often the case. Considered from any viewpoint, the results obtained fully justified the efforts which were made.

RAILWAYS IN SHANTUNG, CHINA.—The details of the amalgamation of the Shantung Mining Company and the Shantung Railway have now been ascertained. The stockholders of the railway, in session at Berlin, voted to pay \$1,285,000 in railway shares to the shareholders of the mines. It is reported that the main offices will be removed from Germany to Tsingtau. The railway runs from the port of Tsingtau west to Tsinanfu.

## General News.

The roundhouse of the Minneapolis, St. Paul & Sault Ste. Marie at Portage, Wis., was burned on November 12.

The Chicago & Alton coal chutes at Kansas City, Mo., were destroyed by fire on November 13, together with several freight cars.

The car shops of the Boston & Maine at Fitchburg, Mass., were damaged by fire on the evening of November 10; loss, including damage to eight passenger cars, \$60,000.

R. C. Richards, general claim agent of the Chicago & North Western, addressed the Omaha Commercial Club on November 13, on the safety first movement. He urged a national law against trespassing.

The United States Civil Service Commission will hold examinations December 10, for the position of passenger rate clerk for the office of the Quartermaster of the Army, at St. Louis Mo.; salary, \$1,200.

At Boston, a week from next Sunday, Charles S. Mellen, former president of the New York, New Haven & Hartford, will hobnob with leaders of the railroad brotherhoods at a banquet, to be given in his honor and to which they have invited him. Can this be the same exclusive gentleman who failed to recognize his own general superintendent?

On the night of November 6, a bandit robbed the passengers in a Pullman car on the Burlington road, very near Omaha. On the night of November 17, a masked robber held possession of the mail car on a Southern Pacific train between San Jose and San Francisco, for more than an hour, having bound the clerks with ropes. He carried off the registered mail.

James J. Hill and J. M. Hannaford, the new president of the Northern Pacific, were given a complimentary banquet by the Portland (Ore.) Commercial Club on November 8, which was attended by a number of officers of the Hill lines who are making a western tour with Mr. Hill. Addresses were made by Mr. Hill, Mr. Hannaford, L. W. Hill and W. D. Fenton. Mr. Hill in his address urged the necessity of improved agricultural methods and declared that unless the hostile sentiment of legislatures, commissions and some classes of other people is changed the railways will be forced into the hands of the courts, which may lead to government ownership, and government ownership, he prophesied, would be the end of free government in America. "If the valuation which the government is taking of the railroads in the country is taken honestly," he said, "the figures will be much more than the par value of the stocks and bonds together. I know that in the case of the Great Northern we are paying taxes on \$112,000,000 more than we have stocks and bonds."

The United States Civil Service Commission announces examinations for senior and junior land appraisers to fill places under the Interstate Commerce Commission in the valuation of railroad property. Candidates for the position of senior appraiser—salary from \$1,800 to \$3,600—will be examined on written recommendations, which must be filed with the commission by December 22. Candidates for junior appraiser—salary from \$900 to \$1,500—will be examined at the usual places on January 7 next. The New York State Civil Service Commission will hold examinations November 29, for the positions of examiner and assistant examiner of accounts under the Public Service Commission of the Second District; salaries \$1,500 to \$2,400. For these positions the commission desires men between the ages of 25 and 35 who have had practical experience in accounting work on steam railroads; also those who have had experience on street and electric railways; also for three other classes of accounts, electrical corporations, gas corporations and telephone and telegraph corporations. These New York examinations are open to non-residents. Blanks may be secured from the commission at Albany.

The Seamen's bill, designed to make jobs for men belonging to the labor union which controls the destinies of the employees of coastwise and lake steamers, and which has already been passed by the upper house of Congress, prescribes regula-

tions which will be so onerous, as applied to steamers on the lakes and in New York bay, that, if the bill becomes a law, many of these vessels will have to go out of business. The steamers of the Central Railroad of New Jersey, for example, running between Manhattan and Sandy Hook, about 20 miles, wholly in New York bay, which are licensed to carry 2,000 or more passengers, would be required to have 100 lifeboats and a crew of 200 "able seamen" to man those boats in case of danger. The bill, as passed by the Senate, exempts vessels plying wholly in rivers and harbors. The lower part of New York bay is not classed as a harbor, but these vessels run in narrow dredged channels and on either side of these channels the water is so shallow that the vessels could not sink below the water level. Moreover, a vessel in distress can get aid from others in a very few minutes, steam craft of all kinds being always within easy call. The bill was introduced by Senator LaFollette, and is known as S-136. It stipulates that the seamen called for by it must each have had three years' experience on the high seas. Except in the heaviest days of the summer these vessels are loaded far short of their capacity; and in the autumn, when traffic is light, a crew made up as prescribed by this law would, in many cases, be much more numerous than the passengers.

### Standing of Engineering Candidates.

The United States Civil Service Commission finds that of 481 candidates for the position of senior civil engineer, first grade, in the valuation department of the Interstate Commerce Commission, 305 can be marked 80, or above, and 176 between 70 and 80. Whether or not there were candidates (outside the 481) who graded below 70, is not stated, the gradings, by districts, including first and second grades, and also the gradings of structural engineers and signal engineers are given in the following table:

Senior Civil Engineers.	Above 90	80 to 90	70 to 80
District No. I:			
First grade .....	15	82	53
Second grade .....	..	26	86
District No. II:			
First grade .....	12	35	32
Second grade .....	..	14	32
District No. III:			
First grade .....	8	53	29
Second grade .....	..	22	43
District No. IV:			
First grade .....	10	38	36
Second grade .....	..	32	46
District No. V:			
First grade .....	9	43	26
Second grade .....	..	13	65
Total .....	54	358	448
Senior Structural Engineers.			
First grade .....	12	28	17
Second grade .....	..	22	27
Senior Railway Signal Engineers.			
First grade .....	2	13	3
Second grade .....	..	6	31

On request of the Interstate Commerce Commission, candidates may be transferred from one district to another.

All five of the district valuation engineers of the Interstate Commerce Commission have now opened offices in their respective headquarters, and appointments for staff positions are to be made in a few weeks from the list of eligibles.

### The Cause of Automobile Accidents at Highway Crossings.

While actual statistics show that only 1½ per cent. of automobile accidents occur at railway crossings, nevertheless this 1½ per cent. is so large that automobile associations are co-operating with the railroads to minimize the number and stimulate greater care on the part of pedestrians and drivers of motor vehicles. In making an effort to ascertain wherein the responsibility for crossing accidents might rest, some observations were recently made by one of the railroads with office in San Francisco, and the statement of the results, involving 16,522 motor vehicles, 4,246 teams and 4,528 pedestrians, shows that 69 per cent. of the drivers of motor vehicles took no precautions whatever to prevent being struck at crossings, 21 per cent. passing at a high rate of speed. The observations were made in San Francisco, Lodi, Stockton, Oakland and Sacramento. The total of the pedestrians and drivers of teams and motor vehicles who crossed during the

period of observation was 25,296. Of this number 35 stopped and looked in both directions before crossing; 8,950 kept moving and looked in both directions; 1,694 kept moving and looked in one way only, and 14,617 kept moving and looked straight ahead.

**The Course In Railroadng.**

Walker M. Van Riper, who has made a study of legislation affecting railroads and public service corporations, tells this: "At a time when the legislature of the new state of Arizona was passing a big batch of bills affecting railroads, a young man called on President Wilde of the University of Arizona, and asked him if a course of instruction in the railroad business could be had in the university. The president said perhaps it could be arranged, and the young man then asked how long it would take and how much it would cost.

"That depends on how much you want to learn," President Wilde told him. "If you want to learn as much as a division superintendent knows, it will take 10 years and cost you \$10,000. If you want to know as much about the railroad business as the Arizona legislature knows, it will take 15 minutes and will cost you 75 cents."—*St. Louis Post Dispatch.*

**The First Pullman Car.**

Fifty-six years ago J. L. Barnes, of Chanute, Kan., was a conductor on the first Pullman car ever run. He made the trip between Bloomington, Ill., and Chicago over the Chicago & Alton on the night of September 1, 1857, and one of his passengers was George M. Pullman. Mr. Barnes recalls that Mr. Pullman on the next morning was somewhat doubtful as to the ultimate success of his invention. Mr. Barnes is 78 years old and it would probably be rather unfair to visit him with the punishment to which he is clearly entitled, but he told how he stood idly by and permitted the first Pullman porter in history to maltreat a passenger with a whisk broom and collect the original Pullman tip. He was a husky lad of 22 summers at that time and his muscles were in a good state of vigor, but he did not interfere.

The car was a remodelled day coach and there were built four compartments, eight berths, four upper and four lower. The people of Bloomington, little reckoning that history was being made in their midst, did not come down to the station to see the car. There was no crowd and the car, lighted by candles, moved away in solitary grandeur, if such it might be called.

Mr. Barnes retired as division superintendent of the Atchison, Topeka & Santa Fe in 1910, after a railroad service covering fifty-six years.—*Exchange.*

**Canada's New Transcontinental Railroad.**

With a gap of but a few miles to fill in before all of the steel of that portion of the National Transcontinental Railway for which the government is responsible has been laid down, its construction thus far has cost Canada in round figures, \$135,000,000. The estimated cost of the road at its completion, about September 1914, is placed by the engineers at \$150,000,000. This does not include the cost of the Quebec bridge, which in one sense is a part of the road. The amounts of money paid out of the consolidated revenue of the Dominion each year since 1904 towards the construction of the road, are as follows:

1904.....	\$6,249	1910.....	\$19,968,064
1905.....	778,491	1911.....	23,487,986
1906.....	1,841,269	1912.....	21,110,352
1907.....	5,537,867	1913.....	18,787,059
1908.....	18,910,253		
1909.....	24,892,351	Total .....	\$135,319,945

**A Weekly Bulletin for Agents and Yard Masters.**

To keep a large mass of facts well in hand requires system, review and study; and especially is this true where the facts change, from day to day, like a kaleidoscope, as in the operation of a railroad. Station agents and yardmasters should review their fields frequently. On the Chesapeake & Ohio they are aided in doing this by a weekly bulletin from E. P. Goodwin, superintendent of transportation. From a recent issue of this bulletin we extract the following typical paragraphs:

**Box Cars.**—Shortage about 450. You have pulled this down from 1,300. Keep pulling until you make a surplus. We then get both revenues and per diem. *Don't* hold a car for tomor-

row's loading when you can unload one that will do for the same order. *Don't* delay placing for unloading and pulling when loaded. *Don't* tie up cars with company's material.

**Flat Cars.**—If you can not load *at once*, the Greenbrier District can.

**Stock and Coke Cars.**—The 500 leased stock (Nos. 90500 to 90599) should put us on Easy Street. Take care of local requirements; then, the farther you load them off line the more money we make.

**Coalers.**—This is serious. It would take the National Militia to drive them home, therefore, it is strictly up to *you* to save every day, hour and minute. Make up in efficiency what we lack in equipment.

**Personal.**—Our passenger trains and time freight trains are not making the record they should. There is possibly a thousand things that go to make up delays. Are you responsible for any one of this thousand? Recently noticed car on Big Four delayed two months waiting on a bill from C. & O. Just figure what that consignor and consignee are saying about railroad service. Noticed car delayed 18 days for S. A. L., another mix-up of billing. Noticed frequently cars with company's material held 10 to 20 days *for unloading.*

**Lives Saved on the North Western.**

On the Chicago & North Western the "Safety First" movement has now been in vogue over three years and the company has issued a statement showing the reduction in the number of personal casualties in a period of three years and four months, a record for a longer time than has been published by any other road. The record is for forty months ending October 31, 1913, as compared with forty months at the rate shown in the records for the twelve months ending June 30, 1910, and is as follows:

	Per cent.
40 fewer trainmen killed, a decrease of.....	30.8
4,327 fewer trainmen injured, a decrease of.....	40.0
22 fewer switchmen killed, a decrease of.....	36.1
458 fewer switchmen injured, a decrease of.....	19.8
19 fewer stationmen killed, a decrease of.....	79.1
593 fewer stationmen injured, a decrease of.....	22.7
34 fewer trackmen killed, a decrease of.....	34.7
1,463 fewer trackmen injured, a decrease of.....	24.7
2 fewer bridgemen killed, a decrease of.....	18.2
102 fewer bridgemen injured, a decrease of.....	11.8
560 fewer shop and roundhouse men injured, a decrease of.....	12.7

There were increases as follows: 2 car repairers killed, 366 car repairers injured, 2 shop men killed, 5 unclassified employees killed, 68 unclassified employees injured, and 7 passengers killed.

A summary shows 261 fewer persons killed, a decrease of 21.6 per cent., and 7,706 fewer persons injured, a decrease of 22.7 per cent.

**Chicago Terminal Problem.**

Bion J. Arnold, who sometime ago was engaged by the Citizens' Committee to make a study of the railway terminals of Chicago and to review the report on the same subject made by J. F. Wallace, submitted his report to the Council Committee on Terminals last Tuesday. Mr. Arnold recommends that the city grant no ordinances that do not conform to a satisfactory and harmonious scheme for the rearrangement of terminals. He favors a plan under which all the roads on the south side of the city would use the Illinois Central Terminal and those on the west side join in building on a site west of the river at Harrison street. With the new station of the North Western this would make three terminals in the city. The entire terminal situation is reviewed at length, with elaborate detailed studies. A comprehensive plan for reorganization is worked out, with several alternative plans. Provision is made for the connection of all the stations with each other by subway lines, and the plans contemplate a possible through routing of suburban trains.

**Length of Service of North Western Officials.**

Twenty-seven of the general officers of the Chicago & North Western had a dinner at the Union League Club, Chicago, on November 10, for the purpose of holding a "family council" on the affairs of the company and of getting together socially, as it is their practice to do occasionally. During the dinner the fact that a large proportion of them had spent most of their active railway careers on the North Western was discussed, and it was suggested that each one write on a card that was circulated, the number of years he had been with the com-

pany. The total of years of service was 724, or an average of 27 years for each officer present. The longest period of service with the company was 44 years. There was one period of 43 years, three of 40, one of 36, three of 35 and one of 34.

A list of those present, with the year on which each entered the service of the North Western, and his first position with the road is as follows:

- W. A. Gardner, president, 1878, clerk.
- R. H. Ashton, vice-president, 1878, axman.
- H. R. McCullough, vice-president, 1880, in general freight department.
- A. C. Johnson, passenger traffic manager, 1894, special agent.
- C. A. Cairns, general passenger and ticket agent, 1892, in general passenger department.
- E. D. Brigham, assistant freight traffic manager, 1873, telegrapher.
- W. D. Cantillon, general manager, lines east of Missouri river, 1878, brakeman.
- Frank Walters, general manager, lines west of Missouri river, 1902, assistant superintendent.
- S. G. Strickland, assistant general manager, 1880, telegrapher.
- Walter J. Towne, general superintendent, lines east of Missouri river, 1897, assistant engineer on construction.
- George B. Vilas, assistant general superintendent, lines east of Missouri river, 1909, station work.
- L. S. Carroll, general purchasing agent, 1884, station helper.
- W. M. Carroll, general storekeeper, 1889, clerk.
- Ralph C. Richards, general claim agent, 1870, office boy.
- H. C. Howe, freight claim agent, 1884, bill clerk.
- Robert Quayle, general superintendent motive power and car departments, 1871, machinist apprentice.
- H. T. Bentley, superintendent motive power and machinery, 1892, machinist.
- C. A. Schroyer, superintendent car department, 1886, assistant superintendent car department.
- A. B. Jones, local treasurer, 1884, office boy.
- William Bennett, superintendent of telegraph, 1869, telegraph messenger.
- E. E. Betts, superintendent transportation, 1888, office boy.
- T. H. Goodnow, assistant superintendent car department, 1912, assistant superintendent car department.
- Charles D. Brandriff, general auditor, 1897, clerk.
- H. H. Decker, engineer of maintenance, 1899, rodman.
- L. J. Putnam, assistant chief engineer, 1899, instrumentman.
- F. H. Hammill, assistant general superintendent, 1886, telegrapher.

#### Disastrous Wreck at Clayton, Ala.

In the derailment of a northbound excursion train on the Central of Georgia near Clayton, Ala., on the 13th of November, nine passengers were killed and 200 or more were injured. Six of the injuries are classed as fatal; the seriously injured number about 40. The train was running at good speed and the three rear coaches ran off the track at a curve. These coaches were crowded with passengers and they fell down a bank 40 ft. high. The frames of the cars were wrecked and hardly a single person escaped injury. Of the five cars in the train the two leading cars, with the locomotive, remained on the track.

The immediate cause of the derailment was a broken rail; but it is said that the ties were in very poor condition.

The railroad company, in accordance with its custom, asked a committee of citizens to take part in the investigation following the wreck, but when the hearings were closed, and the officers of the road were ready with a decision holding that a broken rail was responsible for the wreck, the citizens refused to agree to that conclusion, holding that probably a faulty roadbed was the cause. The citizens' committee was composed of Judge of Probate T. D. Grubbs, T. M. Patterson, mayor of Clayton, and O. B. Pruett, a merchant.

The Birmingham *Age-Herald* in its report of the investigation says:

"There can be no doubt that the wreck was caused by a broken rail, but there is every reason to believe that the rail broke for want of proper support. The cross ties at the point where the three coaches left the track are nearly all in a bad condition. This was shown when the Clayton committee, appointed to assist in the public investigation, visited the scene of the accident this afternoon [November 14]. An examination of the track showed that nearly one out of every three or four of the ties was rotten, some of them being in so dilapidated a condition as to crumble at the ends when kicked. Mr. Pruett, one of the committee, kicked the end off four or five of the ties within a space of a dozen yards."

The section master testified that the train was running about 40 miles an hour.

The general manager of the road gave out a statement in which he said:

"The usual equipment of the train was one coach and one combination car. The train on this occasion consisted of four coaches and one combination car, and was crowded with between 400 and 500 excursionists going to the county fair at Eufaula. The

attendance on Tuesday and Wednesday had been small, and no information had been received that such a large crowd would travel to the fair on Thursday; otherwise, more ample accommodations could and would have been furnished.

"The train was running only five minutes late at Clayton, and consumed 10 or 12 minutes in running the 3½ miles from Clayton to the point where the accident occurred. The derailment occurred on a descending grade and on a 2 deg. curve. It is hardly probable, therefore, that the train was running more than 30 miles an hour, which was neither unusual nor excessive speed.

"The engineer states that he felt the broken rail as he passed over it and applied the brakes. The engine and two cars passed safely over the break and the three rear cars were derailed and turned over, two turning over on one side of the embankment and one on the other. The track was laid with 56-lb. steel rails, on pine and cypress ties, which were reported in good condition.

"The latest report is to the effect that as the result of the accident there have been nine deaths. [Names given.] . . . The officers of the company greatly deplore the accident and are doing everything in their power for the relief and care of the injured."

#### Train Service Demoralized By Ohio Storm.

Railway service through the northern part of Ohio and particularly in the vicinity of Cleveland, was badly demoralized on Sunday, Monday and Tuesday of last week, November 9, 10 and 11, by the worst storm that the region has known for many years. At Cleveland twenty-four inches of snow fell during the three days, accompanied by a gale that overthrew telegraph wires and piled up drifts that completely blocked the railways for many hours, and made the train service very irregular for four days.

The worst effects of the storm on railway operation were felt in the district between Ashtabula and Elyria and south of those points. In Cleveland the snow was drifted so deep and so many wires and poles fell across the streets that street car service was almost entirely discontinued, and even the downtown streets were blocked. Telegraph service along the line of the New York, Chicago & St. Louis was destroyed for a distance of over 100 miles, and similar conditions prevailed on other lines, while all local telephone and telegraph service was destroyed, and even after tracks had been somewhat cleared it was necessary for operating officers to go out in light engines to ascertain conditions. On Monday the New York Central offices in Chicago had no communication east of Toledo. For two days Cleveland was almost isolated. Through trains passing through the city were from 12 to 28 hours late, the Twentieth Century Limited arriving in Chicago on Monday at 5 p. m., and trains originating at Cleveland were annulled by the Lake Shore, Big Four and Pennsylvania. Cuts filled with drifts made the tracks impassable and telegraph poles fallen across the right of way amid a tangle of wires added to the difficulty. Train crews were obliged to make their way as best they could without running orders and the officers in many cases knew nothing of where the trains were. A train that left Cleveland for Pittsburgh proceeded for two hours and was then stalled for twenty-six hours.

On Tuesday all roads operated trains out of the city irregularly and on Wednesday conditions were greatly improved by a cessation of the snowfall. As the efforts of the railways were concentrated on the passenger trains few freight trains were moved in the vicinity of Cleveland, and for two or three days the city was seriously threatened with a shortage of food.

#### American Railway Association.

The fall meeting of the American Railway Association was held at the Blackstone, Chicago, on Wednesday of this week, the representation being 210 members by 200 delegates.

The executive committee reported that the membership now comprises 402 members operating 269,317 miles of road, an increase of 43 members and 2,045 miles. The associate membership now comprises 146 members operating 8,513 miles, an increase of 8 members and 447 miles. The increase in the number is largely due to changes which have been caused by

the new provisions for membership under article 4 of the articles of organization.

The executive committee reported that Arthur Hale had been reappointed general agent of the association for the ensuing two years.

In accordance with the request of the executive committee to report upon a workable organization of "safety first" committees on railroads, conclusions and recommendations were submitted by the executive committee to the association and approved at the session held last May. A circular has been issued by the committee to the members of the association, in order to ascertain what progress has been made in this movement. A further report will be submitted on the subject at a later meeting. Amendments to sections 5 and 4 of the detour agreement were presented, which were approved by the association.

The committee reported in connection with the work of revision of the standard code of train rules, that it has obtained from the members of the association copies of the rules in actual force upon their lines, which were compared and reported upon by an experienced examiner of trainmen of a railway having a heavy traffic. The committee has also been aided by an auxiliary committee of active railway officers who are in daily touch with the problems of transportation.

The committee reported that in its opinion the present code as it stands has proved satisfactory, when properly interpreted and rigidly adhered to. It is where its provisions have been disobeyed that disasters have followed; and before recommending any changes the committee feels that it must be thoroughly satisfied as to the advantage which will be gained in the direction of either safety or efficiency.

The committee on maintenance reported that the question of modifying the specification for carbon steel rails, as provisionally approved by the association in November, 1912, to provide for a variation of  $\frac{3}{8}$  in. from the specified length instead of  $\frac{1}{4}$  in. has been referred to the American Railway Engineering Association for its consideration and recommendation.

The question of the contour of chilled car wheels and the throat clearances for frogs, cross overs and guard rails has been referred to the American Railway Engineering Association and the Master Car Builders' Association jointly for a full investigation and report.

In order to obtain full information as to the present practice, the committee has issued a circular of inquiry on switchstand clearances.

The attention of the committee has been called to the fact that a worsted test for color perception, which is claimed to be the standard of the American Railway Association, is being offered to the railroads which does not conform to the standard as prescribed by the association. It is of the first importance that primary standards only should be used; those which have been established by the proper tests and certified to for distribution to the members of the association; and this can only be accomplished by having the equipment examined and certified to by the official examiner selected by the committee.

The committee stated that the subject of the standard dimensions of box cars is still under consideration, and a circular has been issued in order to ascertain the views of the members relative to the advisability of changing the present standard inside dimension, viz: 36 ft. in length, 8 ft. 6 in. in width, and 8 ft. in height to 40 ft. 6 in. in length, 8 ft. 6 in. in width and 9 ft. in height, with maximum outside dimensions of 9 ft. 2 in. in width at 13 ft. above the top of the rail, and 9 ft. in height. The committee hopes to be able to present a final report next May.

The committee also included in this report a summary of replies to circular No. 1317, respecting the number of freight cars, passenger cars and locomotives equipped with safety appliances as required by the United States safety appliance standards, as of July 1, 1913.

The joint committee on automatic train stops presented a revision of the "requisites of installation" for automatic train control, etc., in which a number of changes have been made from those tentatively reported at the May meeting of the association. After the discussion the report was referred back to the joint committee for further consideration.

The committee on the safe transportation of explosives and other dangerous articles reported that F. G. Shepard, vice-president, Missouri Pacific, and M. C. Kennedy, president, Cumber-

land Valley, have been elected as members thereof to fill vacancies.

The hearing appointed by the Interstate Commerce Commission to consider proposed amendments to the regulations for the transportation of explosives and dangerous articles was postponed at the suggestion of the committee. No date for the hearing has as yet been set. The committee reported that since the last meeting the American Express Company, Globe Express, Great Northern Express Company, Northern Express Company, and Wells Fargo & Company Express have become members of the bureau of explosives.

The committee on electrical working reported that it is giving attention to the questions of overhead working conductors clearances and to the clearances for automatic train stops.

The committee desires that conclusions as to these questions shall be reached by the railway technical associations, which are also considering them, before recommending action to the association.

The entire afternoon session was taken up with consideration of the report of the Committee on Relations Between Railways. A wide variance of opinion developed regarding the recommendation relative to changes proposed in the per diem reclaim rule, and adjournment was taken to December 3, when another meeting will be held in Chicago to settle this matter.

D. L. Bush, vice-president of the Chicago, Milwaukee & St. Paul, and C. W. Galloway, general manager of the Baltimore & Ohio, were elected members of the committee on nominations. The Canadian Pacific, the Chicago, Rock Island & Pacific and the Philadelphia & Reading were elected members of the committee on safe transportation of explosives and other dangerous articles. The Baltimore & Ohio and the Chicago, Milwaukee & St. Paul were elected members of the committee on electrical working. The spring meeting will be held in New York, May 20, 1914.

#### American Society of Mechanical Engineers.

The annual meeting of the American Society of Mechanical Engineers will be held in New York, December 2-5. On the evening of December 2 there will be the presidential address, followed by a reception. On the morning of December 3 there will be a business meeting, followed by professional session, with the following papers: Notes on the Further Operation of Large Boilers of the Detroit Edison Company, by J. W. Parker; On Setting Tasks for Firemen and Maintaining High Efficiency in Boiler Plants, by Walter N. Polakov, and Properties of Steam, by R. C. H. Heck. In the afternoon the railroad session will be held at which the following papers will be presented: Steel Underframe Box Cars, by G. W. Rink, and Steel Frame Box Cars, by R. W. Burnett. The cement and textile sessions will be held simultaneously with the railroad session. In the evening there will be the presentation of the Grashof medal by the Verein Deutscher Ingenieure to George Westinghouse, past-president and honorary member, the American Society of Mechanical Engineers, which will be followed by an address, illustrated by lantern views, on Leonardo da Vinci—Engineer and Artist, by John W. Lieb, Jr., past president, American Institute of Electrical Engineers, and past vice-president, the American Society of Mechanical Engineers.

On the morning of December 4 the following papers will be presented: Efficiency of Rope Driving as a Means of Power Transmission, by E. H. Ahara; Comparative Tests of Three Types of Lineshaft Bearings, by Carl C. Thomas, E. R. Maurer and L. E. Kelso; Pitot Tubes for Gas Measurements, by W. C. Rowse; Tests of Vacuum Cleaning Systems, by J. R. McColl; Tests Upon the Transmission of Heat in Vacuum Evaporators, by E. W. Kerr; and The Art of Enameling, or the Coating of Steel and Iron with Glass, by Raymond F. Nailler. On the same morning will be held the machine shop practice session at which papers will be presented on Continuous Manufacturing by Placing Machines in Accordance with Sequence of Operations, by Oscar F. Bornholt; Gears for Machine-Tool Drives, by John Parker; Cast-Iron for Machine-Tool Parts, by Henry M. Wood, and A Record of Pressed Fits, by C. F. MacGill. The gas power session will also be held on the morning of December 4. On the afternoon of December 4 there will be excursions to points of interest in New York

and vicinity. On that evening there will be a German dinner, reproducing one of the menus from the trip abroad, and will be held at the Deutscher Liederkrantz at half past six o'clock. A brief account of the trip illustrated by lantern slides will be given by Past President Worcester R. Warner. An informal dance will follow the dinner as was customary in Germany.

On the morning of December 5 there will be the fire protection session at which the following papers will be presented: The Fire Hazard in Turbo-Generators, by G. S. Lawler; Extinguishing Fires in Oils and Volatile Liquids, by Edw. A. Barrier; and Control of Automatic Sprinkler Valves, by Fred J. Miller. On that afternoon there will be excursions to points of interest in New York and vicinity, followed in the evening by college reunions.

#### Special Committee on the Relations of Railway Operation to Legislation.

The semi-annual meeting of the Special Committee on the Relations of Railway Operation to Legislation was held in Chicago, November 19. The report rendered showed that 333 railroads, having a total mileage of 223,675 miles, were supporting the work of the committee. Details of bills affecting operation now pending in congress were also shown and the committee said that it was satisfied that a number of these bills will be passed at the session of congress which will convene in December. The committee added that other subjects would be brought up and that very broad additions to the discretionary power of the Interstate Commerce Commission over railway operation would be proposed. Chairman W. J. Jackson, in a brief address, said that the committee had offered to present the views of railways on the intricate subject of enlarging the powers of the Interstate Commerce Commission over operations to the commission, but that the commission could not see its way clear to discuss the matter with the men who were prepared to meet it. Mr. Jackson said that it was therefore the purpose of the committee to ask the same body of men to present this matter before the committee of congress; as it has, to do with such matters as legislation making compulsory the adoption of steel passenger cars, the reduction of clearances and extension of block signals, and the installation of automatic stops, with other legislation affecting operation, involving expenditures estimated at more than two billion dollars. "It would," said Mr. Jackson, "appear unthinkable that congress will take the responsibility of ordering these without giving very grave consideration to the question of where the funds are to be secured, and to the effect on the continuance of capital expenditures, which should be made in other directions for the proper handling of traffic. The alternative is obviously the delegation of wide discretionary powers over operation to the Interstate Commerce Commission. At the present time congress may enact legislation involving expenditure of those huge sums while the commission can prevent increases in revenues which must be obtained before money can be secured. Under these circumstances it is most essential that the roads stand ready to respond promptly to calls for witnesses by sending the most efficient men available for that service. It is also urged that very serious consideration be given to the question whether approval should be given to the general proposition to extend the powers of the commission.

#### Central and Western Association of Car Service Officers.

The semi-annual meeting of the Central and Western Association of Car Service Officers was held at the Hotel La Salle, Chicago, on November 13, with President D. C. Fredericks, superintendent of transportation of the Chicago, Peoria & St. Louis, in the chair.

Reports were received from the committee on office methods and accounting and the committee on per diem rules.

Following the reports of the committees there was a general discussion of M. C. B. Rule 120, providing for the disposition of unserviceable cars, with reference to the method of billing for the rate of 2½ cents per mile for the transportation home empty. Arthur Hale, chairman of the Committee on Relations Between Railways of the American Railway Association, said that the Interstate Commerce Commission had issued a conference ruling

that the 2½ cent charge is not a freight rate but a reciprocal charge, that goes into the miscellaneous freight receipts but cannot be used on a regular waybill. Some other way must therefore be devised for handling it. He could see no difficulty in settling by bill and voucher.

J. R. Pickering, superintendent of car service of the Chicago, Rock Island & Pacific, suggested the use of an interline empty car way-bill, with a coupon for each handling road, on which to bill the car through to destination after having received instructions as to the shortest home route.

Mr. Hale also spoke on the proposed cancellation of per diem rule 5, to abolish reclaim allowances, which has been postponed to January 1. He said that Commissioner Harlan of the Interstate Commerce Commission was anxious to see the reclaim abolished because it had been made a source of profit to certain industries owning industrial railways, but that many felt that the 15 or 20 industrial roads should be affected rather than the rule. It has also been suggested that reclaim allowances be based on actual time instead of an arbitrary amount. At any rate he felt that if any road should withdraw from the per diem agreement because of the abolition of reclaims the other roads would have the sympathy of the commission and that only the question as to what is best for all roads should be considered, without reference to the fear that some lines will withdraw.

J. R. Pickering, L. M. Betts, car accountant of the Chicago & Western Indiana, and W. E. Beecham, car accountant of the Chicago, Milwaukee & St. Paul, were appointed a committee to determine a uniform method of handling home route bad order cars and to present it at the meeting of the Association of Transportation and Car Accounting Officers at Galveston.

#### Railway Business Association.

Over 800 reservations have already been made for the annual dinner of the Railway Business Association, which will be held at the Waldorf-Astoria hotel, New York, on Thursday, December 11.

#### MEETINGS AND CONVENTIONS.

*The following list gives names of secretaries, dates of next or regular meetings, and places of meeting.*

- AIR BRAKE ASSOCIATION.—F. M. Nellis, 53 State St., Boston, Mass. Next convention, May, 1914.
- AMERICAN ASSOCIATION OF DEMURRAGE OFFICERS.—A. G. Thomason, Boston, Mass. Convention, May 19, 1914, St. Louis.
- AMERICAN ASSOCIATION OF GENERAL PASSENGER AND TICKET AGENTS.—W. C. Hope, New York.
- AMERICAN ASSOCIATION OF FREIGHT AGENTS.—R. O. Wells, East St. Louis, Ill. Next convention, April 21, Houston, Tex.
- AMERICAN ASSOCIATION OF RAILROAD SUPERINTENDENTS.—E. H. Harman, St. Louis, Mo.; 3d Thursday and Friday in May.
- AMERICAN ELECTRIC RAILWAY ASSOCIATION.—H. C. Donecker, 29 W. 39th St., New York.
- AMERICAN ELECTRIC RAILWAY MANUFACTURERS' ASSOC.—H. G. McConaughy, 165 Broadway, New York. Meetings with Am. Elec. Ry. Assoc.
- AMERICAN RAILWAY ASSOCIATION.—W. F. Allen, 75 Church St., New York.
- AMERICAN RAILWAY BRIDGE AND BUILDING ASSOCIATION.—C. A. Lichty, C. & N. W., Chicago. Next convention, October 20-22, 1914, Los Angeles, Cal.
- AMERICAN RAILWAY ENGINEERING ASSOCIATION.—E. H. Fritch, 900 S. Michigan Ave., Chicago. Next convention, March 17-20, Chicago.
- AMERICAN RAILWAY MASTER MECHANICS' ASSOCIATION.—J. W. Taylor, Karpen building, Chicago.
- AMERICAN RAILWAY TOOL FOREMEN'S ASSOCIATION.—A. R. Davis, Central of Georgia, Macon, Ga.
- AMERICAN SOCIETY FOR TESTING MATERIALS.—Prof. E. Marburg, University of Pennsylvania, Philadelphia, Pa.
- AMERICAN SOCIETY OF CIVIL ENGINEERS.—C. W. Hunt, 220 West 57th St., New York; 1st and 3d Wed., except June and August, New York.
- AMERICAN SOCIETY OF ENGINEERING CONTRACTORS.—J. R. Weninger, 11 Broadway, New York; 2d Tuesday of each month, New York.
- AMERICAN SOCIETY OF MECHANICAL ENGINEERS.—Calvin W. Rice, 29 W. 39th St., New York.
- AMERICAN WOOD PRESERVERS' ASSOCIATION.—F. J. Angier, B. & O., Baltimore, Md. Next convention, January 20-22, 1914, New Orleans, La.
- ASSOCIATION OF AMERICAN RAILWAY ACCOUNTING OFFICERS.—C. G. Phillips, Highland Park, Ill. Annual meeting, June 24, Minneapolis, Minn.
- ASSOCIATION OF RAILWAY CLAIM AGENTS.—C. W. Egan, B. & O., Baltimore, Md. Next convention, May, 1914, St. Paul, Minn.
- ASSOCIATION OF RAILWAY ELECTRICAL ENGINEERS.—Jos. A. Andreucetti, C. & N. W. Ry., Chicago.
- ASSOCIATION OF RAILWAY TELEGRAPH SUPERINTENDENTS.—P. W. Drew, 112 West Adams St., Chicago. Next convention, May 20-23, New Orleans, La.

## Traffic News.

**ASSOCIATION OF TRANSPORTATION AND CAR ACCOUNTING OFFICERS.**—G. P. Conard, 75 Church St., New York. Next meeting, December 9-10, Galveston, Tex.

**ASSOCIATION OF WATER LINE ACCOUNTING OFFICERS.**—W. R. Evans, Chamber of Commerce, Buffalo, N. Y.

**BRIDGE AND BUILDING SUPPLY MEN'S ASSOCIATION.**—L. D. Mitchell, Detroit Graphite Co., Detroit, Mich. Meeting with American Railway Bridge and Building Association.

**CANADIAN RAILWAY CLUB.**—James Powell, Grand Trunk Ry., Montreal, Que.; 2d Tuesday in month, except June, July and Aug., Montreal.

**CANADIAN SOCIETY OF CIVIL ENGINEERS.**—Clement H. McLeod, 413 Dorchester St., Montreal, Que.; Thursday, Montreal.

**CAR FOREMEN'S ASSOCIATION OF CHICAGO.**—Aaron Kline, 841 North 50th Court, Chicago; 2d Monday in month, Chicago.

**CENTRAL RAILWAY CLUB.**—H. D. Vought, 95 Liberty St., New York; 2d Thurs. in Jan. and 2d Fri. in March, May, Sept., Nov., Buffalo, N. Y.

**CIVIL ENGINEERS' SOCIETY OF ST. PAUL.**—L. S. Pomeroy, Old State Capitol building, St. Paul, Minn.; 2d Monday, except June, July, August and September, St. Paul.

**ENGINEERS' SOCIETY OF PENNSYLVANIA.**—E. R. Dasher, Box 704, Harrisburg, Pa.; 1st Monday after second Saturday, Harrisburg, Pa.

**ENGINEERS' SOCIETY OF WESTERN PENNSYLVANIA.**—E. K. Hiles, Oliver building, Pittsburgh; 1st and 3d Tuesday, Pittsburgh, Pa.

**FREIGHT CLAIM ASSOCIATION.**—Warren P. Taylor, Richmond, Va. Next convention, May 20-22, Galveston, Tex.

**GENERAL SUPERINTENDENTS' ASSOCIATION OF CHICAGO.**—E. S. Koller, 226 W. Adams St., Chicago; Wed. preceding 3d Thurs., Chicago.

**INTERNATIONAL RAILWAY CONGRESS.**—Executive Committee, 11, rue de Louvain, Brussels, Belgium. Convention, 1915, Berlin.

**INTERNATIONAL RAILWAY FUEL ASSOCIATION.**—C. G. Hall, 922 McCormick building, Chicago. Annual convention, May 18-22, Chicago.

**INTERNATIONAL RAILWAY GENERAL FOREMEN'S ASSOCIATION.**—Wm. Hall, 829 West Broadway, Winona, Minn. Next convention, July, Chicago.

**INTERNATIONAL RAILROAD MASTER BLACKSMITHS' ASSOCIATION.**—A. L. Woodworth, Lima, Ohio. Next convention, third Tuesday in August.

**MAINTENANCE OF WAY & MASTER PAINTERS' ASSOCIATION OF THE UNITED STATES AND CANADA.**—W. G. Wilson, Lehigh Valley, Easton, Pa.

**MASTER BOILER MAKERS' ASSOCIATION.**—Harry D. Vought, 95 Liberty St., New York.

**MASTER CAR BUILDERS' ASSOCIATION.**—J. W. Taylor, Karpen building, Chicago.

**MASTER CAR & LOCOMOTIVE PAINTERS' ASSOC. OF U. S. AND CANADA.**—A. P. Drnc, B. & M., Reading, Mass.

**NATIONAL RAILWAY APPLIANCE ASSOC.**—Bruce V. Crandall, 537 So. Dearborn St., Chicago. Meetings with Am. Ry. Eng. Assoc.

**NEW ENGLAND RAILROAD CLUB.**—W. E. Cade, Jr., 683 Atlantic Ave., Boston, Mass.; 2d Tuesday in month, except June, July, Aug. and Sept., Boston.

**NEW YORK RAILROAD CLUB.**—H. D. Vought, 95 Liberty St., New York; 3rd Friday in month, except June, July and August, New York.

**NORTHERN RAILROAD CLUB.**—C. L. Kennedy, C. M. & St. P., Duluth, Minn.; 4th Saturday, Duluth.

**PEORIA ASSOCIATION OF RAILROAD OFFICERS.**—M. W. Rotchford, Union Station, Peoria; 2d Thursday.

**RAILROAD CLUB OF KANSAS CITY.**—C. Manlove, 1008 Walnut St., Kansas City, Mo.; 3d Friday in month, Kansas City.

**RAILWAY BUSINESS ASSOCIATION.**—Frank W. Noxon, 2 Rector St., New York. Annual dinner, December 11, 1913, New York.

**RAILWAY CLUB OF PITTSBURGH.**—J. B. Anderson, Penna. R. R., Pittsburgh, Pa.; 4th Friday in month, except June, July and August, Pittsburgh.

**RAILWAY ELECTRICAL SUPPLY MANUFACTURERS' ASSOC.**—J. Scribner, 1021 Monadnock Block, Chicago. Meetings with Assoc. Ry. Elec. Engrs.

**RAILWAY FIRE PROTECTION ASSOCIATION.**—C. B. Edwards, Mobile & Ohio, Mobile, Ala.

**RAILWAY GARDENING ASSOCIATION.**—J. S. Butterfield, Lee's Summit, Mo.

**RAILWAY DEVELOPMENT ASSOCIATION.**—W. Nicholson, Kansas City Southern, Kansas City, Mo.

**RAILWAY SIGNAL ASSOCIATION.**—C. C. Rosenberg, Bethlehem, Pa.

**RAILWAY STOREKEEPERS' ASSOCIATION.**—J. P. Murphy, Box C, Collinwood, Ohio.

**RAILWAY SUPPLY MANUFACTURERS' ASSOC.**—J. D. Conway, 2135 Oliver bldg., Pittsburgh, Pa. Meetings with M. M. and M. C. B. Assocs.

**RAILWAY TEL. & TEL. APPLIANCE ASSOC.**—W. E. Harkness, 284 Pearl St., New York. Meetings with Assoc. of Ry. Teleg. Sups.

**RICHMOND RAILROAD CLUB.**—F. O. Robinson, Richmond, Va.; 2d Monday except June, July and August.

**ROADMASTERS' AND MAINTENANCE OF WAY ASSOCIATION.**—L. C. Ryan, C. & N. W., Sterling, Ill.

**ST. LOUIS RAILWAY CLUB.**—B. W. Frauenthal, Union Station, St. Louis, Mo.; 2d Friday in month, except June, July and Aug., St. Louis.

**SIGNAL APPLIANCE ASSOCIATION.**—F. W. Edmonds, 3868 Park Ave., New York. Meeting with annual convention Railway Signal Association.

**SOCIETY OF RAILWAY FINANCIAL OFFICERS.**—C. Nyquist, La Salle St. Station, Chicago.

**SOUTHERN ASSOCIATION OF CAR SERVICE OFFICERS.**—E. W. Sandwich, A. & W. P. Ry., Montgomery, Ala.

**SOUTHERN & SOUTHWESTERN RAILWAY CLUB.**—A. J. Merrill, Grant bldg., Atlanta, Ga.; 3d Thurs., Jan., March, May, July, Sept., Nov., Atlanta.

**TOLEDO TRANSPORTATION CLUB.**—J. G. Macomber, Woolson Spice Co., Toledo, Ohio; 1st Saturday, Toledo.

**TRACK SUPPLY ASSOCIATION.**—W. C. Kidd, Ramapo Iron Works, Hillsburn, N. Y. Meetings with Roadmasters' and Maintenance of Way Association.

**TRAFFIC CLUB OF CHICAGO.**—W. H. Wharton, La Salle Hotel, Chicago.

**TRAFFIC CLUB OF NEW YORK.**—C. A. Swope, 290 Broadway, New York; last Tuesday in month, except June, July and August, New York.

**TRAFFIC CLUB OF PITTSBURGH.**—D. L. Wells, Erie, Pittsburgh, Pa.; meetings monthly, Pittsburgh.

**TRAFFIC CLUB OF ST. LOUIS.**—A. F. Versen, Mercantile Library building, St. Louis, Mo. Annual meeting in November. Noonday meetings October to May.

**TRAIN DESPATCHERS' ASSOCIATION OF AMERICA.**—J. F. Mackie, 7122 Stewart Ave., Chicago. Next convention, June 16, Jacksonville, Fla.

**TRANSPORTATION CLUB OF BUFFALO.**—J. M. Sells, Buffalo; first Saturday after first Wednesday.

**TRANSPORTATION CLUB OF DETROIT.**—W. R. Hurley, L. S. & M. S., Detroit, Mich.; meetings monthly.

**TRAVELING ENGINEERS' ASSOCIATION.**—W. O. Thompson, N. Y. C. & H. R., East Buffalo, N. Y. Next meeting, Chicago.

**UTAH SOCIETY OF ENGINEERS.**—Fred D. Ulmer, Oregon Short Line, Salt Lake City, Utah; 3rd Friday of each month, except July and August.

**WESTERN CANADA RAILWAY CLUB.**—W. H. Rosevear, P. O. Box 1707, Winnipeg, Man.; 2d Monday, except June, July and August, Winnipeg.

**WESTERN RAILWAY CLUB.**—J. W. Taylor, Karpen building, Chicago; 3d Tuesday of each month, except June, July and August.

**WESTERN SOCIETY OF ENGINEERS.**—J. H. Warder, 1735 Monadnock Block, Chicago; 1st Monday in month, except July and August, Chicago.

The Ann Arbor announces that its car ferry between Frankfort and Menominee, Mich., will be discontinued for the winter season on December 10. It is expected to resume operation about April 1.

The extra fare of \$10 which was charged on the Sunset Limited train on the Southern Pacific between New Orleans and San Francisco when the train ran only once a week has been discontinued now that the train runs daily.

The Southwestern Traffic Committee, following a conference at Chicago on November 13 with representatives of a large number of shipping organizations, announced that it would cancel its circular making a charge for tariffs and that money already collected would be refunded.

A new passenger train was placed in service on November 16 by the Chicago, Rock Island & Pacific between Minneapolis, St. Paul and Kansas City, leaving Minneapolis at 2:05 p. m., and arriving at Kansas City at 8:30 a. m. the following day to connect with the Golden State Limited.

Beginning on December 2, a standard sleeping car will be run weekly between Winnipeg, Man., and Los Angeles, Cal., over the Canadian Pacific and the Soo Line to St. Paul, the Omaha and North Western to Omaha, the Union Pacific, and the San Pedro, Los Angeles & Salt Lake to Los Angeles.

The Grand Trunk, the Canadian Pacific, and the Canadian Northern have filed with the Canadian Railway Commission new tariffs making a general advance of 5 per cent. in freight rates—an advance calculated on the same basis as that which is proposed in the United States by the principal roads east of the Mississippi river.

Samuel O. Dunn, editor of the *Railway Age Gazette*, will address the Traffic Club of Chicago on November 25, on "The Railway Employee and the Railway Patron," dealing especially with the effect both on the railways and the traveling public of recent changes in wages and working conditions of employees that have been brought about by arbitration proceedings and legislation.

In California, where the demurrage on all freight cars delayed by consignees an unreasonable length of time is \$3 a day, one agent reports that the manager of an iron works, employing 135 men, calls men out of the shops, when necessary, to assist in unloading cars so as to avoid paying demurrage. He pays his ordinary laborers \$2 a day, but when the free time is nearly up it is found profitable to put on some higher-priced men rather than pay \$3 for a fractional part of a day.

The Chicago & Northwestern and the Union Pacific on November 16 reduced the schedule of the San Francisco Limited train by 1 hour and 45 minutes westbound and 9 hours and 20 minutes east bound. The train will leave Chicago at 9:30 p. m., arriving at San Francisco at 7:45 p. m. the third day, or 7¼ hours through, the difference in time between the two cities being 2 hours. Eastbound it will leave San Francisco at 5 p. m. and arrive at Chicago at 4:30 p. m. the third day, or 6¾ hours through. On the same date the Oregon-Washington Limited will be changed to leave Chicago at 9:30 p. m. instead of 8:30, arriving at Portland at 7:15 p. m. the third day.

B. D. Caldwell, president of Wells, Fargo & Co., in his annual report, says that the parcel post competition met in the latter half of the fiscal year ended June 30 cost the company approximately \$1,250,000 in gross earnings. He warns stockholders that further inroads on the company's business may be expected as a result of the extension of the weight limit within the 150-mile radius. Continuing, he says: "The company is now confronted with the most difficult problem in its history as a result of the radical reduction in rates ordered by the Interstate Commerce Commission. Many of the new rates are lower than those of the parcel post. Estimates reached by their application to actual business of typical days indicate from 12 to 15 per cent. reduction in the company's rates as a whole. . . ."

Roads members of the Western Classification Committee have under consideration and will take a vote on a plan of reorgan-

ization of the committee providing for several permanent members who would maintain headquarters at Chicago and give continuous attention to that work of the committee which involves changes in classification ratings and other provisions, instead of leaving all to be dealt with at stated meetings held at various places, usually semi-annually. Under the present plan the members of the committee are delegated by the various roads and at the regular meetings handle very large dockets. If the plan is carried out it would probably mean the abandonment of the meeting called to be held at Monterey, Cal., in January. Such a plan has been advocated by the National Industrial Traffic League, and it is understood it is approved by the Interstate Commerce Commission.

President Ripley, of the Atchison, Topeka & Santa Fe, has notified farmers in Colorado and other states traversed by his road that if they will continue raising garden truck and fruit next year his road will establish a special refrigerator service adapted to their needs. Through this means

Mr. Ripley believes he will overcome the present problem of many farmers—losses suffered because local markets are glutted and the expense of selling in small quantities at distant markets, which consumes the difference between the cost of production and the selling price. The new plans provide for running regular refrigerator cars which on given days will pick up small fruit and vegetable consignments. These shipments will be taken to terminal points, where each variety of fruit or vegetable will be made into carload lots and then taken to market. It is said that President Ripley was impelled to this step by paying five cents each for peaches in Kansas City, and the next day observing a wagonload of peaches being fed to hogs near the Colorado-Kansas line.

**Car Surpluses and Shortages.**

Arthur Hale, chairman of the committee on relations between railroads of the American Railway Association, in presenting statistical bulletin No. 155, giving a summary of car surpluses and

Date	No. of roads.	Surpluses				Shortages				Total	
		Box.	Flat. and hopper.	Coal, gondola.	Other kinds.	Box.	Flat. and hopper.	Coal, gondola.	Other kinds.		
Group *1.—November 1, 1913.....	7	0	0	86	225	311	461	130	67	5	663
" 2.—" 1, 1913.....	33	438	51	428	320	1,237	1,161	6	2,331	7	3,505
" 3.—" 1, 1913.....	27	47	237	220	451	955	4,389	85	3,100	817	8,391
" 4.—" 1, 1913.....	13	3,157	677	691	568	5,093	2,325	432	4,960	587	8,304
" 5.—" 1, 1913.....	23	23	232	287	549	1,091	966	60	607	10	1,643
" 6.—" 1, 1913.....	28	1,865	211	1,134	2,536	5,746	1,992	35	363	575	2,965
" 7.—" 1, 1913.....	4	186	153	34	737	1,110	10	0	118	0	128
" 8.—" 1, 1913.....	18	732	217	1,218	1,850	4,017	818	39	390	7	1,254
" 9.—" 1, 1913.....	13	3,828	203	425	716	5,172	200	0	13	18	231
" 10.—" 1, 1913.....	24	2,669	1,057	2,197	6,505	12,428	1,543	119	146	369	2,177
" 11.—" 1, 1913.....	5	284	334	0	498	1,116	9,053	625	500	679	10,857
Grand total .....	195	13,229	3,372	6,720	14,955	38,276	22,918	1,531	12,595	3,074	40,118

\*Group 1 is composed of New England lines; Group 2—New York, New Jersey, Delaware, Maryland and Eastern Pennsylvania lines; Group 3—Ohio, Indiana, Michigan and Western Pennsylvania lines; Group 4—West Virginia, Virginia, North and South Carolina lines; Group 5—Kentucky, Tennessee, Mississippi, Alabama, Georgia and Florida lines; Group 6—Iowa, Illinois, Wisconsin and Minnesota lines; Group 7—Montana, Wyoming, Nebraska, North Dakota and South Dakota lines; Group 8—Kansas, Colorado, Missouri, Arkansas and Oklahoma lines; Group 9—Texas, Louisiana and New Mexico lines; Group 10—Washington, Oregon, Idaho, California, Nevada and Arizona lines; Group 11—Canadian lines.

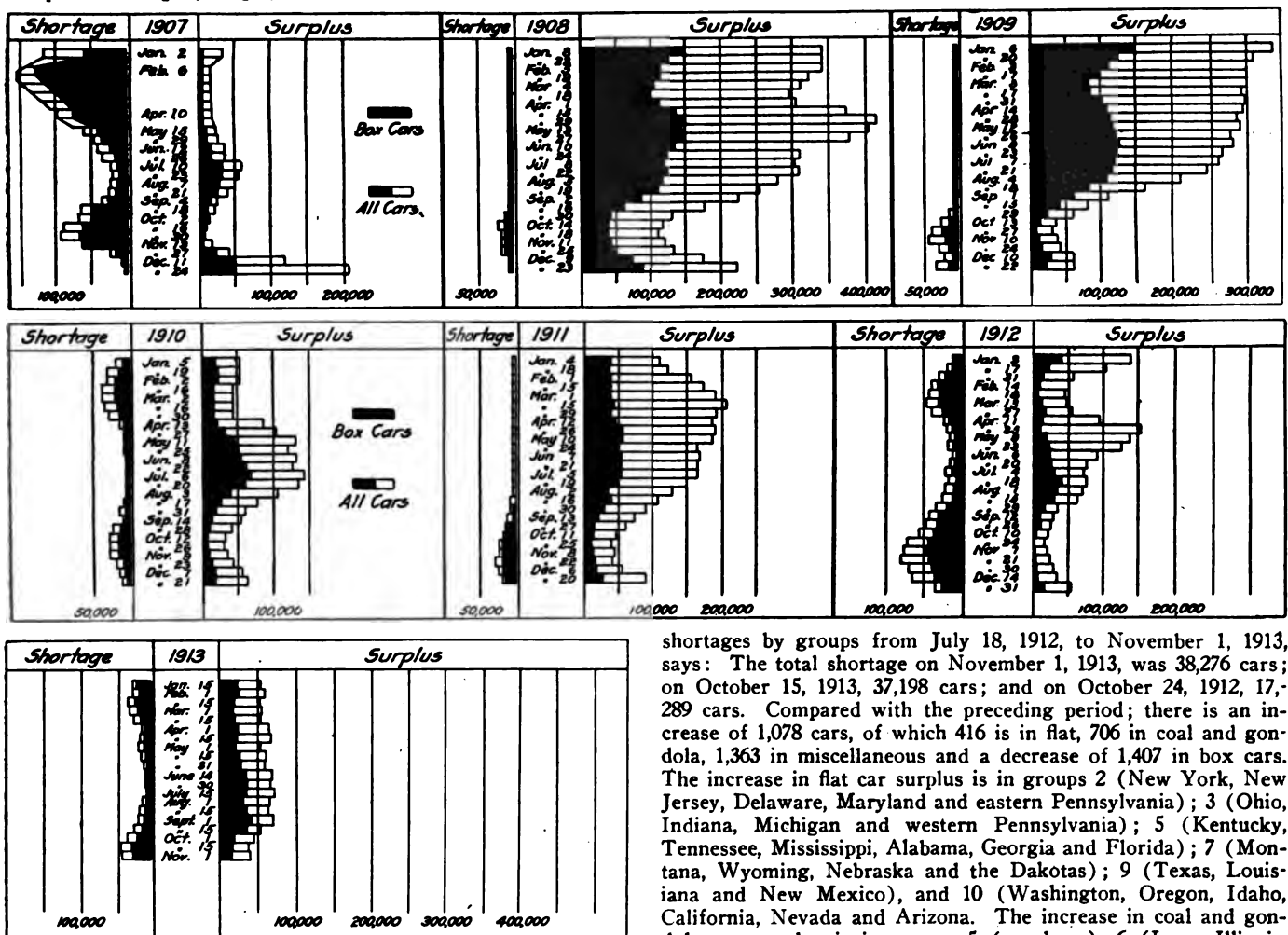

Car Surpluses and Shortages, 1907 to 1913.

shortages by groups from July 18, 1912, to November 1, 1913, says: The total shortage on November 1, 1913, was 38,276 cars; on October 15, 1913, 37,198 cars; and on October 24, 1912, 17,289 cars. Compared with the preceding period; there is an increase of 1,078 cars, of which 416 is in flat, 706 in coal and gondola, 1,363 in miscellaneous and a decrease of 1,407 in box cars. The increase in flat car surplus is in groups 2 (New York, New Jersey, Delaware, Maryland and eastern Pennsylvania); 3 (Ohio, Indiana, Michigan and western Pennsylvania); 5 (Kentucky, Tennessee, Mississippi, Alabama, Georgia and Florida); 7 (Montana, Wyoming, Nebraska and the Dakotas); 9 (Texas, Louisiana and New Mexico), and 10 (Washington, Oregon, Idaho, California, Nevada and Arizona). The increase in coal and gondola car surplus is in groups 5 (as above), 6 (Iowa, Illinois, Wisconsin and Minnesota); 8 (Kansas, Colorado, Oklahoma,



Missouri and Arkansas) and 10 (as above). The increase in miscellaneous car surplus is in groups 1 (New England Lines); 4 (the Virginias and Carolinas); 5, 6, 7, 8 and 10 (as above). The decrease in box car surplus is in groups 2, 3, 8, 10 (as above) and 11 (Canadian Lines).

The total shortage on November 1, 1913, was 40,118 cars; on October 15, 1913, 43,246 cars; and on October 24, 1912, 67,270 cars. Compared with the preceding period; there is a decrease in the total shortage of 3,128 cars, of which 2,103 is in box, 579 in flat and 539 in miscellaneous car shortage, and an increase of 92 in coal and gondola car shortage. The decrease in box car shortage is in groups 4, 5, 6 and 7 (as above). The decrease in flat car shortage is in all groups, except 2 and 11 (as above). The decrease in miscellaneous car shortage is in groups 2, 3, 5, 7 and 8 (as above). The increase in box car shortage is in groups 1, 2, 3, 8, 9, 10 and 11 (as above).

Compared with the corresponding period of 1912; there is an increase in the total car surplus of 20,987 cars, of which 11,050 is in box, 2,175 in flat, 1,597 in coal and gondolas and 6,165 in miscellaneous car surplus. There is a decrease in the total car shortage of 27,152 cars, of which 17,438 is in box, 3,503 in flat, 5,781 in coal and gondolas, and 430 in miscellaneous car shortage.

The accompanying table gives car surplus and shortage figures by groups for the last period covered in the report and the diagram shows total bi-weekly surpluses and shortages from 1907 to 1913.

#### Increase Passenger Rates.

From canvasses that have been made it is quite apparent that a majority of the manufacturers and shippers are in favor of an advance of 5 per cent. in freight rates. We suppose this conclusion is reached because the shipping public feels that the labor unions have taken so much money away from the railroads in increased wages that it is absolutely necessary to allow the advance.

*Manufacturers' News* is in favor of going to the mat with the labor union organizations controlling the railroad situation. It seems to us the thing to do is to give the railroads authority to increase the passenger rates. If every person who rides on a railroad, especially that great army of citizens who use commutation tickets, was compelled to pay a little more car fare every time a brotherhood forced an increase in wages, public sentiment would be materially changed.

An incident occurred in England not long ago which strongly illustrates what would happen if the railroads had power to put the increased wages on the passenger side of the books. One union that had to do with the operating of the railroads, went on a strike in England for an increase in wages. An arbitration committee was appointed and with the usual result a compromise was effected and the men obtained a considerable advance. The railroads immediately placed the advance on the passengers. Not long afterwards, the engineers concluded they would reach into the railroad crib and take a little more money, so they threatened to strike. Public sentiment rose up so strongly that they were forced to withdraw their demands. The people saw at once that another increase meant another increase in passenger rates.—*Manufacturers' News*.

### INTERSTATE COMMERCE COMMISSION.

#### Rates on Citrus Fruits Reduced.

*Railroad Commissioners of the State of Florida v. Atlantic Coast Line et al. Opinion by Commissioner Prouty:*

The commission found that the rate of 33 cents per 100 lbs., c. l., and 35 cents per 100 lbs. l. c. l., for the transportation of citrus fruits from landings on the upper Caloosahatchee river in Florida to Jacksonville, Fla., when for beyond are unreasonable to the extent that they exceed 31 cents c. l. and 34 cents l. c. l., and prescribed those rates for the future. (28 I. C. C., 356.)

#### Storage Charges in Central Freight Association Territory.

*Opinion by Commissioner Clements:*

The commission found that the uniform storage rules and rates filed by carriers in Central Freight Association territory,

were unreasonable in certain particulars, and in view of the substantial increases permitted in storage charges on explosives and other dangerous articles, the carriers will be required to notify consignors, in case request is properly made of failure or refusal of consignees to remove shipments of such articles within the time prescribed. (28 I. C. C., 372.)

#### Dates from Which Reparation is to Be Awarded.

*In re Investigation of Alleged Unreasonable Rates and Passages Involved in the Transportation of Live Stock, Packing House Products and Fresh Meat from Various Southwestern Points to Packing Houses, and Thence to Various Destinations. Corporation Commission of Oklahoma v. Atchison, Topeka & Santa Fe, et al. Opinion by Commissioner Prouty:*

This case involves the dates from which reparation is to be awarded on shipments of live stock, fresh meat and packing house products between points in Texas, Oklahoma, and other territory. The commission on December 11, 1911, established certain reasonable rates on these commodities, 22 I. C. C., 160, and subsequently, on May 13, 1912, made certain slight modifications in those rates, 23 I. C. C., 656. The commission decided that following the conclusions reached in *Wool Investigation*, 25 I. C. C., 675, reparation should be awarded from the date of the promulgation of the original opinion, subject to the two-year limitation from the date of filing petition for reparation. (28 I. C. C., 332.)

#### Columbia, S. C. Discriminated Against.

*Columbia Chamber of Commerce v. Southern Railway, et al. Opinion by Commissioner McChord:*

In this case the complainant contends that Columbia, S. C., is unduly discriminated against in favor of Augusta, Ga., in rates from eastern and western points of origin. Augusta and Columbia are similarly located so far as transportation by rail is concerned inland from Savannah, Ga., and Charleston, S. C., and also with respect to competition with each other and with the ports named. On traffic from the east the carriers recognize similarity of rail situations by equalizing the class rates to these cities. The commission decided that with respect to commodity rates from the east and to class and commodity rates from Cincinnati, Ohio; Louisville, Ky., and Knoxville, Tenn., the differences in the rail location of the two cities in question, or in their competitive relationship to the ports, are not sufficient to justify the present differences in rates in favor of Augusta, and ordered that in future the rates from these points of origin to Columbia should not exceed the rates from the same points to Augusta. The commission also ordered that on specific commodities by rail, or by water-and-rail, from Baltimore, Md., to Columbia, rates shall not exceed those from the same points to Augusta. Rates on classes and on specific commodities from Cincinnati, Louisville and Knoxville, must not exceed those from the same places to Augusta. From the lower Ohio river crossings and the Mississippi river crossings and from Nashville, no change need be made in the present differentials over or under the rate from Cincinnati-Louisville to Augusta or to Columbia, as Columbia will derive all the relief in the rates from these gateways to which it is entitled by reason of location through the adjustment of the rates from Cincinnati-Louisville. (28 I. C. C., 339.)

### STATE COMMISSIONS.

The Illinois Railroad and Warehouse Commission has suspended tariffs, advancing Illinois freight rates by approximately 5 per cent. from November 15 to March 12, 1914.

The Ohio Utilities Commission has ordered the Wabash Railroad to limit the speed of trains over a stretch of 80 miles of its line in northern Ohio because of unsatisfactory condition of the track.

The Kansas public utilities commission will hold a hearing December 18, to investigate the efficiency of the transportation facilities and service furnished at the Kansas City stock yards by the stock yards company and other carriers.

REVENUES AND EXPENSES OF RAILWAYS.

MONTH OF SEPTEMBER, 1913.

Name of road.	Average mileage operated during period.		Operating revenues			Operating expenses			Net operating revenue (or deficit).	Outside operations, net.	Taxes.	Operating income (or loss).	Increase (or decrease) last year.
	Freight.	Passenger.	Total.	Way and structures.	Maintenance of equipment.	Traffic.	Transportation.	General.					
Alabama Great Southern	309	\$284,851	\$437,411	\$57,994	\$103,378	\$14,714	\$140,992	\$8,983	\$111,545	-\$163	\$15,700	\$95,682	\$20,656
Arizona Eastern	367	172,272	39,305	33,000	33,701	1,922	61,668	10,880	81,610	76	14,147	67,539	-43,031
Atlantic & St. Lawrence	167	65,225	140,265	30,581	30,358	4,807	60,547	5,325	76	2,970	10,157	-10,081	-15,228
Atlantic City	167	44,527	222,440	33,381	30,381	2,700	115,560	1,067	58,688	2,970	9,000	46,718	-9,125
Baltimore & Ohio—System	4,456	7,135,703	9,197,853	1,604,171	1,556,590	198,674	3,287,585	206,229	2,744,604	-68,282	269,197	2,407,125	93,279
Bingham & Garfield	26	150,989	4,436	155,788	22,014	5,667	24,233	2,559	100,370	.....	3,028	97,342	60,121
Burlingame & Pacific	90	98,916	122,440	18,194	18,900	975	46,198	2,904	33,665	.....	3,228	33,415	12,841
Canadian Pacific Lines in Maine	233	52,713	23,063	85,759	34,600	16,145	38,470	5,463	100,479	.....	11,000	-2,562	-2,562
Central Vermont	536	229,562	124,628	380,795	55,012	77,806	176,467	8,873	53,493	907	15,500	38,900	-50,690
Chicago & Eastern Illinois	1,282	1,070,102	282,128	1,466,305	324,446	350,650	511,751	38,644	214,220	-3,095	45,000	166,125	-85,241
Chicago, Indianapolis & Louisville	617	411,961	166,145	635,345	93,989	96,776	226,303	14,582	179,816	.....	24,373	155,443	-41,678
Chicago, Milwaukee & St. Paul	9,690	6,107,385	1,888,273	8,675,623	1,297,065	1,282,023	165,377	134,562	2,900,451	46,167	332,336	2,614,282	-43,574
Cincinnati, New Orleans & Texas Pacific	337	685,446	190,545	916,659	91,912	239,876	242,108	18,916	300,383	621	31,000	270,004	3,247
Colorado & Southern	1,131	604,085	821,261	118,082	189,486	10,249	230,706	21,588	251,150	-777	30,675	19,698	25,498
Delaware & Hudson Co.—R. R. Dept.	854	1,697,470	346,208	2,106,778	150,626	321,419	691,900	57,593	856,723	-2,679	49,700	804,344	15,569
Denver & Rio Grande	2,585	1,612,524	626,629	2,339,314	365,018	384,324	46,669	52,832	830,201	3,485	97,000	736,686	-90,374
Detroit & Toledo Shore Line	299	127,756	128,885	13,933	9,574	1,688	33,548	2,655	68,187	.....	3,900	62,287	17,555
Detroit, Grand Haven & Milwaukee	191	115,000	73,000	219,579	33,123	25,693	101,741	5,382	35,458	.....	3,600	41,855	21,141
Duluth, South Shore & Atlantic	627	175,599	112,625	310,625	110,867	34,962	109,164	10,950	34,978	2,303	18,000	19,281	-26,105
Duluth, Winnipeg & Pacific	166	104,443	20,278	129,561	26,641	20,713	60,421	5,315	115,147	.....	6,478	7,936	2,531
Florida East Coast	683	144,149	100,302	279,786	72,658	63,963	4,792	118,871	8,781	-1,509	20,000	-12,728	-10,496
Fort Worth & Denver City	454	270,874	143,325	434,805	57,657	83,587	162,526	14,889	109,842	-798	18,200	90,844	-39,496
Galveston, Harrisburg & San Antonio	1,338	825,006	271,450	1,145,523	89,174	212,744	34,948	395,249	32,645	-1,835	56,939	321,871	-40,063
Georgia	307	197,418	76,889	262,796	66,579	49,251	10,988	132,637	63,402	.....	2,950	60,452	40,798
Grand Trunk Western	347	361,000	214,000	613,127	64,298	115,204	26,695	289,302	97,914	-1,659	31,500	64,755	-90,953
Great Northern	7,748	6,407,389	1,763,702	8,646,052	1,086,407	859,524	119,967	2,009,553	4,459,949	30,752	436,879	4,053,822	520,199
Hocking Valley	352	648,886	96,679	801,990	89,634	129,933	7,835	242,105	316,553	.....	41,000	275,553	20,047
Houston, East & West Texas	191	83,847	124,259	13,682	10,230	1,993	39,596	5,203	54,709	.....	5,473	49,236	-3,964
Houston & Texas Central	789	460,147	179,325	677,234	66,206	85,540	24,228	17,373	247,962	-70	29,781	218,111	8,907
International & Great Northern	1,160	787,980	218,341	1,063,573	91,428	121,518	14,633	30,758	420,488	-843	24,841	394,804	-102,841
Louisiana & Arkansas	279	107,679	22,208	134,779	25,926	19,130	2,429	36,576	45,577	.....	4,166	41,411	9,179
Louisiana Western	208	135,593	63,262	209,571	20,773	34,737	6,969	60,611	79,649	.....	3,675	76,228	22,550
Minneapolis, St. Paul & Sault Ste. Marie	3,976	1,982,960	696,696	2,828,180	340,905	410,085	57,050	823,785	1,140,152	29,087	129,758	1,039,481	-197,856
Missouri, Kansas & Texas System	3,817	1,853,202	823,292	2,874,535	406,414	353,109	62,320	1,035,718	942,320	-13,742	106,990	801,914	-168,830
Missouri, Oklahoma & Gulf	332	772,961	21,016	974,316	18,929	18,929	6,417	7,497	97,533	362	6,000	5,855	-3,885
Morgan's La. & Texas R. R. & S. S. Co.	404	256,755	99,812	384,619	46,397	67,584	9,137	150,052	98,962	-2,002	18,250	78,710	14,163
New Orleans, Texas & Mexico	286	89,325	17,056	112,308	32,562	10,866	3,440	48,577	3,440	.....	-1,434	2,006	-13,442
New York Central & Hudson River	3,751	6,107,228	3,579,907	10,825,398	1,605,147	1,939,460	3,562,555	253,111	3,268,788	13,925	534,354	2,748,359	285,859
New York, Chicago & St. Louis	566	835,182	166,100	1,033,518	126,418	160,813	46,490	400,083	282,571	-2,420	36,000	244,151	-62,256
New York, Ontario & Western	566	622,922	165,016	830,333	143,104	143,058	11,813	284,802	230,652	-1,794	18,000	210,858	-9,046
Norfolk Southern	569	162,137	67,684	252,880	33,618	41,076	5,053	12,847	75,182	.....	9,210	65,641	-20,692
Oahu Ry. & Land Co.	101	66,864	26,094	98,600	9,001	7,087	6,651	4,515	55,286	-331	6,580	41,495	-5,255
Oregon, Washington, Railroad & Nav. Co.	1,914	1,227,213	535,618	1,873,558	263,983	193,337	52,403	562,298	737,291	-12,882	112,968	611,441	-128,421
Pecos & Northern Texas	482	156,235	41,238	206,368	27,294	33,557	3,312	64,826	74,621	.....	8,222	66,105	9,502
Philadelphia & Reading	1,020	3,270,242	640,098	4,101,768	482,096	786,363	44,617	1,337,318	1,390,287	15,657	102,869	1,303,133	-42,615
Port Reading	21	111,999	.....	113,523	20,357	1	30	32,403	59,038	-6,617	10,000	42,421	-64,218
St. Louis Merchants' Bridge Terminal	9	.....	.....	167,886	48,204	12,731	749	86,104	14,394	.....	5,600	8,794	-37,584
San Pedro, Los Angeles & Salt Lake	1,133	524,148	261,580	845,422	100,818	159,891	29,628	276,795	261,243	-1,317	40,378	219,548	-66,125
Southern	7,036	3,792,119	1,695,023	5,905,776	854,592	968,826	178,376	1,994,782	1,738,972	673	207,149	1,532,496	-113,433
Southern Pacific Co.	6,329	5,125,434	2,650,068	8,406,807	900,583	1,115,855	155,738	2,249,908	3,756,766	183,344	401,289	3,538,821	-471,140
Spokane International	163	69,189	24,850	99,411	13,577	4,357	27,837	3,434	48,140	.....	3,020	45,120	4,465
Spokane, Portland & Seattle	556	289,270	153,000	480,561	61,614	66,895	8,204	111,308	249,382	1,787	53,400	197,769	9,858
Terminal Railroad Ass'n of St. Louis	34	.....	217	256,801	50,233	20,337	955	92,576	88,273	3,101	26,700	64,883	-28,211
Texas & New Orleans	458	237,953	110,362	366,632	42,997	76,246	8,386	141,896	84,347	-1,601	19,376	63,370	15,930
Texas & Pacific	1,885	1,037,874	387,973	1,523,811	220,631	276,034	41,779	615,052	330,775	-6,115	48,300	276,360	68,848
Union Pacific	3,611	3,608,104	1,030,675	5,056,610	597,535	609,648	105,040	1,202,194	2,416,055	-4,675	176,087	2,235,902	-237,902
Vandalia	910	729,552	241,034	1,072,113	145,875	183,098	28,787	383,570	311,169	.....	30,316	280,853	-45,998
Virginia & Southwestern	240	148,928	17,945	172,243	24,032	40,850	1,944	47,224	54,524	.....	5,909	48,615	14,997
Virginian	503	519,090	36,936	569,534	77,973	90,459	6,598	120,910	263,964	7,750	20,075	251,639	100,217
Wabash	2,515	1,834,941	699,595	2,765,862	289,089	469,212	83,690	1,042,338	1,953,109	-4,121	74,448	1,734,734	-108,773
Western Maryland	661	596,272	110,932	739,469	122,981	108,088	22,193	311,945	155,370	.....	19,000	136,370	-27,844
Western Pacific	934	468,490	135,056	618,942	118,786	59,246	29,769	202,344	183,638	-1,744	31,707	150,187	-38,843

Arthur B. duBray, inspector of electric signals of the St. Louis & San Francisco, with office at Springfield, Mo., has been appointed signal engineer for the Missouri Public Service Commission, with headquarters at Jefferson City, Mo., effective December 1.

The New York State Public Service Commission, First district, has ordered the Long Island Railroad to discontinue, as far as possible, the use of wooden cars in its electrically propelled trains; and from September 15, 1914, to discontinue them absolutely; that is to say, to have all electric trains made up wholly of steel cars.

The Committee on Express Service and Rates, Martin S. Decker, chairman, which was appointed by the National Association of Railway Commissioners at the recent convention in Washington, will hold a meeting in Chicago, December 11, to consider a uniform method of prescribing rates for the intrastate transportation of merchandise by express. Mr. Decker proposes that the individual states adopt a plan similar to that which has been prescribed by the Interstate Commerce Commission for interstate express traffic throughout the whole country.

J. L. Harrop, engineer of the Missouri Public Service Commission, has submitted a report recommending the abolition of a large number of grade crossings of streets and railways in St. Louis, the cost to be divided between the railways and the city. The roads are required by an order of the commission to submit plans for the improvements within a specified time and meanwhile to protect crossings by the installation of gates or automatic alarm signals. Several roads have notified the commission that they will comply at once with the latter order.

The Railroad Commission of Louisiana has imposed a fine of \$500 on the Yazoo & Mississippi Valley for failing to comply with the flagging rule established by the Commission some months since. On the evening of September 26, at Pecan Grove, a freight train, backing into a siding, was run into by a following passenger train, and four persons were injured. The conductor of the freight instructed the flagman not to go back; and as the rules of the road hold conductors responsible for the protection of their trains under all conditions, the Commission does not censure him; but the rule prescribed by the Commission requires a flagman to go back, when it is necessary to protect a train, without waiting for an order from the conductor. As the railroad company did not change its regulations to conform to those issued by the Commission, it is now found guilty of unlawful violation of the rule of the Commission. The attorney general of the state is authorized to file a suit to collect the fine.

The New York State Public Service Commission for the First District has ordered the New York Central & Hudson River to reduce its one-way fares within the city of New York on the Harlem Division and the Hudson Division, so that the through rate from the Grand Central Terminal to any point inside of the city shall not be in excess of the sum of the local rates for the same distance. For example, the order calls for a reduction from 20 to 15 cents between the Grand Central Terminal and the Botanical Gardens on the Harlem Division, 9½ miles. Under the previous tariff the fare from the Grand Central Terminal to Tremont was 10 cents, and from Tremont to Botanical Gardens 5 cents, making a total of 15 cents, so that the passenger who bought a through ticket had to pay 5 cents more than one who paid his fare on the train first to Tremont and then to Botanical Gardens. The reductions affect the fares to Botanical Gardens, Williamsbridge, Woodlawn and Wakefield on the Harlem Division; and to Marble Hill, Spuyten Duyvil, Riverdale and Mount St. Vincent on the Hudson Division.

#### COURT NEWS.

United States Circuit Judges Warrington, Knappen and Denison, at Columbus, Ohio, have rendered a decision holding that the joint ownership of the Kanawha & Michigan by the Lake Shore & Michigan Southern and the Chesapeake & Ohio is illegal and must cease.

## Railway Officers.

### Executive, Financial and Legal Officers.

President W. C. Brown's resignation from the New York Central Lines is commented on elsewhere in this issue.

F. L. Koontz, assistant secretary and assistant treasurer of the Elgin, Joliet & Eastern, has been elected secretary and treasurer, with headquarters at Chicago, succeeding W. K. Allen, resigned. Edward Beecroft succeeds Mr. Koontz.

Frederick H. Wood, whose appointment as general attorney and commerce counsel of the Southern Pacific Company, with headquarters at New York, has already been announced in these columns, was born on January 2, 1877, at Lebanon, Me. He was educated at the Central High School, Kansas City, Mo., and in 1897, graduated from the Collegiate Department of the University of Kansas, and from the Law School two years later. He began the practice of law in Kansas City in June, 1899. In February, 1905, he was appointed assistant general solicitor of the Kansas City Southern, and in January, 1910, was made general attorney and commerce counsel of the Frisco Lines, with headquarters at St. Louis, Mo., which position he held at the time of his recent appointment as general attorney and commerce counsel of the Southern Pacific Company, as above noted.

Edwin I. Grenfell, whose appointment as auditor of the Fort Worth & Denver City, and consulting auditor of the Wichita Valley, with headquarters at Fort Worth, Tex., has been announced in these columns, was born December 8, 1865, at Dodgeville, Wis. He was educated in the public schools and at St. Marks, Salt Lake City, Utah, and was admitted to practice as attorney and counselor-at-law in Colorado in 1894, and as certified public accountant in 1907. Mr. Grenfell began railway work in January, 1883, with the Union Pacific, being employed as local agent until December, 1893, when, owing to receiverships and segregation of properties, he went with the Union Pacific, Denver & Gulf, which was reorganized in 1899 as the Colorado & Southern. He

entered the auditing department April 1, 1899, as traveling auditor; in September, 1902, became joint accountant, and in December, 1906, was made chief clerk. In July, 1907, he was made assistant general auditor, which position he held until his recent appointment as auditor of the Fort Worth & Denver City, and consulting auditor of the Wichita Valley, as above noted.

### Operating Officers.

H. E. Fell has been appointed trainmaster of the St. Louis, Rocky Mountain & Pacific at Raton, N. M.

J. W. Butz, freight agent of the Missouri, Kansas & Texas at Denison, Tex., has been appointed trainmaster at Greenville, Tex., succeeding K. Randolph, resigned.

Frank O'Brien, assistant superintendent of the Wisconsin division of the Chicago & North Western, has been appointed superintendent of the newly created Southern Illinois division, with headquarters at South Pekin, Ill.

Guy Adams, heretofore mail traffic manager of the St. Louis & San Francisco and the Chicago & Eastern Illinois, has been appointed mail traffic manager of the Union Pacific, with headquarters at Chicago, effective December 1.



E. I. Grenfell.

**Traffic Officers.**

G. W. Adams has been appointed traveling freight agent of the Galveston, Harrisburg & San Antonio, with headquarters at Houston, Tex.

S. M. Wallace has been appointed commercial agent of the St. Louis & San Francisco at Dallas, Tex., succeeding E. F. Hundley, resigned.

C. B. Austin, traveling freight agent of the Western Maryland, at Toledo, Ohio, has been appointed commercial agent with headquarters at Youngstown, Ohio.

James D. Greer has been appointed industrial agent of the Sunset-Central Lines of the Southern Pacific, with headquarters at Houston, Tex., succeeding H. P. Attwater, resigned.

W. B. Durrett has been appointed traveling agent of the Erie Despatch, with office at Little Rock, Ark., and H. H. Weston has been appointed agent, with office at Minneapolis, Minn.

H. E. Still, assistant general freight agent of the Northern Pacific at St. Paul, Minn., has been appointed general western freight agent, with headquarters at Tacoma, Wash., succeeding H. Blakely.

C. W. Mahoney, city passenger and ticket agent of the Great Northern at Spokane, Wash., has been appointed chief clerk to the assistant general passenger agent at Seattle, Wash. J. J. Scherp, traveling passenger agent, with headquarters at Seattle, succeeds Mr. Mahoney and Robert Shaw takes the place of Mr. Scherp.

John B. Baird, who on November 1 became freight traffic manager of the Northern Pacific, as already announced in these columns, was born June 21, 1855, at Woodlawn, Md. He

began railway work in 1876 as a clerk in the general office of the Pennsylvania, at Philadelphia, Pa. Afterwards he went to the Chicago, St. Paul, Minneapolis & Omaha as clerk for the general manager, and subsequently was employed as rate clerk in the general freight office of the Northern Pacific. Later Mr. Baird was promoted to assistant general freight agent of the latter road, in which capacity he served until May 1, 1903. He was then made general freight agent, which position he held until he was appointed freight traffic manager, with head-



J. B. Baird.

quarters at St. Paul, Minn., as above noted.

**Engineering and Rolling Stock Officers.**

M. B. Morgan, roadmaster of the Illinois Central at Fulton, Ky., has been appointed assistant engineer maintenance of way at Chicago, succeeding D. W. Thrower.

J. W. Hackett, formerly roundhouse foreman of the Fort Worth & Denver City at Amarillo, Tex., is now master mechanic of the Houston Belt & Terminal with headquarters at Houston. He succeeded M. D. Stewart, resigned.

M. R. Williams has been appointed general foreman of bridges, buildings and water service of the St. Louis, Rocky Mountain & Pacific, with headquarters at Las Vegas, N. M. F. L. Gumm has been appointed roadmaster at Raton, N. M.

Arthur B. duBray, inspector of electric signals of the St. Louis & San Francisco, with office at Springfield, Mo., has been appointed signal engineer for the Missouri Public Service Commission, with headquarters at Jefferson City, Mo., effective December 1.

William G. Arn has been appointed roadmaster of the Indiana division of the Illinois Central, with headquarters at

Mattoon, Ill., in place of Fred B. Oren, who has been transferred to the St. Louis division as roadmaster, with office at Carbondale, Ill., succeeding John F. Plott, resigned.

Edward M. Sweetman, whose appointment as master mechanic of the Southern Railway, with headquarters at Princeton, Ind., has been announced in these columns, was born on February 22,



E. M. Sweetman.

1874, at Joplin, Mo., and was educated in the common schools. He began railway work on October 16, 1898, with the East Tennessee, Virginia & Georgia line of the Southern Railway as an apprentice. In 1905 he was promoted from machinist to air brake foreman, and in January, 1907, he was made erecting shop foreman. The following April he became roundhouse foreman, and three months later was transferred to Asheville, N. C., as general foreman, remaining in that position until September, 1907, when he was appointed master mechanic, on the Memphis division, with

headquarters at Sheffield, Ala. On January 15, 1910, he was transferred in the same capacity to the Birmingham division, which position he held at the time of his recent appointment as master mechanic on the St. Louis division, with headquarters at Princeton, Ind., as above noted.

**Special Officers.**

Thomas W. Hulme has been appointed real estate agent of the Pennsylvania Railroad, succeeding Benjamin W. Carskadon, deceased. Mr. Hulme was born near Mount Holly, N. J.,



T. W. Hulme.

on August 11, 1868. He received a public school education, and later entered the University of Pennsylvania, and received from that institution the degrees of B. S. and C. E. He entered the service of the Lehigh Valley, in the real estate department, in 1890. During the period of the lease of the Lehigh Valley by the Philadelphia & Reading, February, 1892, to August, 1893, he was in the real estate department of the latter company, and also in the president's office. He returned to the service of the Lehigh Valley upon the termination of the lease and was made assistant real

estate agent, remaining in that position until June, 1904, when he entered the service of the Pennsylvania Railroad in connection with the work of the real estate department in New York City. In November, 1904, Mr. Hulme was made assistant real estate agent of the New York Connecting Railroad, and on May 1, 1905, was appointed assistant real estate agent of the Pennsylvania System East of Pittsburgh, and was transferred to the general office in Philadelphia. Upon the formation in May, 1913, of a committee of eighteen railroad presidents to look after the interests of the railroads in connection with the valuation of their properties by the Interstate Commerce Commission, Mr. Hulme was elected general secretary of the presi-

dents' committee and was furloughed in order that he might so act.

**Purchasing Officers.**

E. A. Clifford, whose appointment as assistant general purchasing agent of the Atchison, Topeka & Santa Fe, with headquarters at Chicago, has already been announced in these columns, was born August 12, 1878, in Ireland. He was educated in the parochial schools of Chicago and at St. Ignatius College, and commenced railway work in April, 1900, in the purchasing department of the Santa Fe. He filled various minor clerical positions in that department until April 1, 1910, when he was made chief clerk, and from the latter position he is now promoted to assistant general purchasing agent, as above noted.

**OBITUARY.**

C. E. Pfender, auditor and traffic manager of the Chicago & Illinois Western, died at Chicago on November 16.

A. Williams, vice-president and general manager of the Ocean Shore Railroad, died at Seattle, Wash., on November 13, aged 56 years.

Joseph E. Harris, formerly agent of the Star Union Line at Indianapolis, Ind., died in that city on November 13, aged 68 years. Mr. Harris was in the active service of the Pennsylvania Lines for 38 years, and was placed on the pension roll in August, 1911.

George W. Kretzinger, of the firm of Kretzinger & Kretzinger, of Chicago, attorneys for the Grand Trunk, died on November 17, aged 67 years. Mr. Kretzinger has represented the legal department of the Grand Trunk in Indiana and Illinois for the past four years, and previous to 1910 he was for 18 years general counsel for the Chicago, Indianapolis & Louisville.

W. P. Johnson, formerly from 1880 to 1887, general passenger agent of the Lake Shore & Michigan Southern, died at his home in Chicago on November 16. Mr. Johnson was born at Whitehall, N. Y., in 1834, and entered railway service in 1852 with the Western Vermont. He was subsequently with the Chicago, Burlington & Quincy, and in 1854 became a clerk in the office of the general ticket agent of the Illinois Central at Chicago. The following year he was made general passenger agent of that road, which position he held until June, 1880, when he resigned to go to the Lake Shore.

Milton C. Roach, who was for 18 years general eastern passenger agent of the New York Central & Hudson River at New York City, died on October 31, at Montrose, Pa. He was born on September 20, 1852, at Erie Pa., and began railway work in 1873, on the Canada Southern, now a part of the Michigan Central, as clerk in the purchasing department. He was then successively bill clerk in the freight office, chief clerk of the ticket accounts in the auditor's office, passenger agent and city ticket agent at Detroit, Mich.; passenger agent for Michigan, western passenger agent and general northern and southern passenger agent. He then served in the passenger department of different roads until he went to the New York Central in January, 1886, as general agent in the passenger department, at Buffalo, N. Y. The following year he was made general eastern passenger agent at New York, and in September, 1904, was promoted to assistant general passenger agent of the same road, remaining in this position until he resigned and left railway work, in 1907. At the time of his death Mr. Roach was engaged in publishing a book in the interest of Greater New York, with especial reference to its facilities for caring for and catering to visitors, tourists and sightseers. He had a wide acquaintance and was one of the prominent passenger officers who aided in organizing the Railroad Freight & Passenger Association of New York twenty-seven years ago. His widow, two sons and two daughters survive him.

**RAILWAY ACTIVITY IN CHINA.**—The long-discussed projects of the Kaumi-Ichoufu railroads and of a steel mill for Tsingtau have been revived. Careful surveys of the commercial possibilities of the territory through which the railroad would pass were made by the German officials toward the close of 1912. The railroad manager in Tsingtau considers the present situation in Europe the chief obstacle to progress.

**Equipment and Supplies.**

**LOCOMOTIVE BUILDING.**

THE LEHIGH & NEW ENGLAND has ordered 6 consolidation locomotives, 3 switching locomotives and one other locomotive from the Baldwin Locomotive Works.

THE SOUTHERN RAILWAY OF PERU has ordered 4 consolidation locomotives from the American Locomotive Company. The dimensions of the cylinders will be 16 in. x 26 in., the diameter of the driving wheels will be 52 in., the steam pressure will be 180 lbs., and the total weight in working order will be 110,000 lbs.

THE NEW JERSEY, INDIANA & ILLINOIS has ordered 1 mogul locomotive from the American Locomotive Company. The dimensions of the cylinders will be 18 in. x 24 in., the diameter of the driving wheels will be 50 in., the steam pressure will be 165 lbs., and the total weight in working order will be 120,000 lbs.

**CAR BUILDING.**

THE CHESAPEAKE & OHIO is in the market for 2,000 coal cars.

THE ATCHISON, TOPEKA & SANTA FE has ordered 140 passenger train cars from the Pullman Company.

THE LEHIGH VALLEY has ordered 75 coaches from the Pullman Company, and 25 baggage cars from the Standard Steel Car Company.

THE WABASH has ordered 500 gondola car bodies from the American Car & Foundry Company, and is now in the market for 1,000 box cars.

THE CHICAGO, ST. PAUL, MINNEAPOLIS & OMAHA has ordered 1 combination coach and smoking car, 11 coaches and 2 cafe cars from the Pullman Company, and 5 smoking cars and 6 baggage cars from the American Car & Foundry Company.

THE CHICAGO & NORTH WESTERN has ordered 9 dining cars, 36 coaches, 4 vestibule-parlor cars, 5 observation cars and 6 chair cars from the Pullman Company, and 27 smoking cars, 30 baggage cars and 8 mail cars from the American Car & Foundry Company.

THE LEHIGH & NEW ENGLAND has ordered 500 fifty-ton, all-steel hopper cars from the Pressed Steel Car Company, and 200 forty-ton, all-steel, drop-bottom gondola cars from the Cambria Steel Company. Some of the specialties on these cars will be as follows:

	Hopper.	Gondola.
Wheels .....	National	.....
Bolsters .....	Gould	Gould
Couplers .....	Gould	Simplex
Journal boxes .....	Symington	McCord
Journal bearings .....	Ajax	Ajax
Draft gear .....	Farlow	Miner
Brake beams .....	Davis	Davis
Air brake .....	Westinghouse	.....

**IRON AND STEEL.**

**GENERAL CONDITIONS IN STEEL.**—During the past week the volume of new business has apparently diminished even more than during the first week of the month, and as a result of smaller specifications and light orders, furnace and mill operations have been further reduced. Some of the independent steel companies in the eastern territory last week ran about 40 per cent. of capacity, but a much smaller percentage was active in the last few days. In the Central West there is much irregularity in mill operations; some are below 50 per cent. and others above 70 per cent., while in exceptional instances full capacity is still being operated. Because of the intermittent character of operations it is most difficult to determine the exact percentage of capacity, but it is estimated that an average of about 65 per cent. of ingot and finished capacity is now operated, with a prospect that there will be further reductions if there is not a sudden increase in specifications due to larger buying and better rolling schedules on contracts already on the books.

## Supply Trade News.

The Quigley Furnace Company has moved its general offices from Springfield, Mass., to 105 West Fortieth street, New York.

The New York Central & Hudson River has for sale a number of second-hand passenger, freight and switching locomotives for immediate delivery. For further particulars apply to the purchasing agent, Grand Central Terminal, New York.

Horace L. Winslow has disposed of his interest in the Okadee Company. He will give his time exclusively to the Horace L. Winslow Company, Inc., owners of the Winslow locomotive boiler washing and refilling system, which has been installed on a number of leading railroads. The offices of Horace L. Winslow Company, Inc., will remain at 990 Old Colony building, Chicago.

The Easton Car & Construction Company, Easton, Pa., a new concern, has purchased all the stock, rights, plants, office records, equipment and good-will of the Ernst-Wiener Company, New York. W. E. Farrell is the leading spirit in the new company. While the change in ownership is complete the business will be conducted as heretofore. The Eastern Car & Construction Company will make industrial railway equipment, including cars, track, and other appurtenances, and, as a new venture, will make plate, tank and structural steel up to ½ in. in thickness. The company has a newly erected plant at Easton, Pa., which is completely equipped with new special machinery specially adapted to the manufacture of the Ernst-Wiener products. Everything will be sold hereafter under the trade name of the Easton Car & Construction Company.

Edwin S. Woods, head of the railway supply firm of Edwin S. Woods & Co., Chicago, died on November 15 at the home of his parents in Chicago. He was the son of Major John L.



Edwin S. Woods.

Woods, who was formerly president of the Allen Paper Car Wheel Company and western representative of the Railway Steel Spring Company, and is now with the Buckeye Steel Castings Company. Edwin S. Woods organized the company, of which he was president in 1903, and was previously vice-president of the Kindl Car Truck Company, Chicago. It is announced that the business of the company will be continued as usual. Mr. Woods was 42 years of age, and was very well known by railway and railway supply men throughout the country.

Adelbert B. Stetson, consulting engineer for the Bucyrus Company of South Milwaukee, Wis., and formerly vice-president of that company, died on October 27, aged 72 years. Mr. Stetson became connected with the Bucyrus Company in 1888, when he was made superintendent of the old plant at Bucyrus, O. He later had charge of the construction of the new plant at South Milwaukee, Wis., and was subsequently general superintendent for 10 years, being chosen vice-president of the company in 1901. He resigned in 1904 to devote his entire time to various dredging and gold-mining interests with which he had been identified for a number of years. Subsequently, however, he again became associated with the Bucyrus Company as consulting engineer, in which capacity he remained until his death. During the past year he gave considerable time to the supervision of gold-dredging operations in Idaho, and while engaged in this work a severe illness made it necessary for him to return to Milwaukee, where an operation was performed which resulted in his death. Mr. Stetson was one of the first Americans to be identified with the construction of the Panama canal.

## Railway Construction.

**ALL RED LINE RAILWAY.**—Incorporation is being asked for in Canada to build a line from the Atlantic coast at a point west of Cape St. Charles, between the Province of Quebec and Labrador, in a general westerly direction via Sugar Loaf Portage, Que., Martin's Falls, Ont., a point at the northern end of Lake Winnipeg, Man., and then north of Montreal Lake, Sask., to Athabaska Landing, Alta., thence via Fort Frazer, B. C., to a point at the head of Dean inlet on the Pacific coast. A number of branch lines are also projected. J. K. Dowsley, Prescott, Ont., is solicitor for the applicants.

**BISMARCK BELLEVUE VALLEY & WESTERN.**—This company, which was organized last year, has increased its capital, it is said, from \$300,000 to \$1,000,000. The plans call for building from Bismarck, Mo., west via Caledonia and Belgrade to Sunlight, thence south via Lesterville, Centerville and Westfork to Bunker, about 50 miles. It is understood that the new capital will be used to build the section from Sunlight to Bunker, about 30 miles. E. E. Evans, president, Bismarck, and H. Rohwer, chief engineer, St. Louis.

**CANADIAN PACIFIC.**—Application has been made to the Canadian parliament by the Ottawa Northern & Western for an extension of time to build lines and extensions as follows: From Waltham, Que., to Pembroke, Ont., thence northwesterly beyond Pembroke passing to the south of Lake Nipissing, thence about 20 miles south of Callander to Sault Ste. Marie, Ont.; a branch from Waltham northwesterly through the province of Quebec to a point in the county of Pontiac; an extension from Aylmer to Hull, Que., thence across the Ottawa river to Ottawa, Ont.; also a line from Shawville, westerly across the Ottawa river to Pembroke, Ont.

The Tilsonburg, Lake Erie & Pacific has asked the Canadian parliament for an extension of time to build from Ingersoll through the counties of Oxford, Perth, Waterloo, Wellington, Dufferin, Grey and Simcoe, or any of them to a point at or near Collingwood, on Georgian Bay, Ont.

The Thessalon & Northern is applying to the Canadian parliament for an extension of time to complete a line from a point on the Algoma branch of the Canadian Pacific about two miles northeast of Thessalon, Ont., southwesterly to the town of Thessalon, thence northwesterly to a point at or near Thessalon station, and from either of these points northerly to the Mississauga river in Gould township. About 3½ miles of this line has been built and is being operated by the Canadian Pacific.

The Canadian parliament has been asked to extend the time for the construction of the South Ontario Pacific from near Woodstock, Ont., through Brantford and Hamilton to the Niagara river, thence connecting by a ferry or bridge with United States railways; a branch from a point near Cooksville or Toronto, through Hamilton to a point west thereof, and an extension from some point on the existing line through Embro and St. Marys to Lake Huron between Bayfield and Kincardine.

**CHICAGO, BURLINGTON & QUINCY.**—A contract has been given to Kilpatrick Brothers & Collins, Lincoln, Neb., to build from Guernsey, Wyo., west to Wendover, six miles, to connect the line from Billings down the Big Horn valley with the Guernsey line along the Platte river. The work will be very heavy and will include six tunnels, one to be 3,000 ft. long. The cost of the work will be about \$2,000,000.

**DALLAS, SOUTHWESTERN TRACTION.**—An officer writes that contracts are to be let about the first of next year to build from Dallas, Tex., southwest via Grand Prairie, Webb, Mansfield, Venus, Alvarado, Keene and Cleburne to Glen Rose, in Somervell county. The bridges to be built include two 150-ft. steel trusses, two 80-ft. plate girders and one 30-ft. girder. E. P. Turner, president; John T. Witt, chief engineer, Dallas. (July 25, p. 169.)

**DENVER & RIO GRANDE.**—An officer writes regarding the report that a branch is to be built southerly from Price, Utah, for a distance of 25 miles, that it is not probable that construction work will be started this season.

## Railway Financial News.

**DETROIT, BAY CITY & WESTERN.**—An officer writes that work is now under way on an extension from Snover, Mich., east to Sandusky, 8 miles, and right of way has been secured for an extension from Sandusky south to Peck, 11.5 miles. (September 19, p. 541.)

**DOMINION ATLANTIC.**—Application has been made to the Canadian parliament for an extension of time to build from the section of the railway formerly known as the Cornwallis Valley Railway, between Kentville and Canning, N. S., westerly to a point on the line between Berwick and Middleton, N. S.

**INTERCOLONIAL.**—A contract has been given to K. A. Morrison, Ottawa, Ont., for work on a diversion of line between Nelson, N. B., and Derby Junction, 2.75 miles. This will complete the diversion of the original lines between Chatham and Derby Junction, the greater portion of which, from Chatham to Nelson, was finished in 1912.

**LEHIGH & NEW ENGLAND.**—An officer writes that a contract has been given to F. H. Clement & Co., Philadelphia, Pa., and work is now under way on a branch from Lehigh Gap, Pa., to Palmerton, 1.18 miles.

**LIBERTY-WHITE.**—An officer writes that the company is building with its own forces a branch from Uniondale, Miss., easterly for a distance of four miles.

**NORTH-WESTERN OF SOUTH CAROLINA.**—An officer writes that contracts have been let to the Smith Kyle Co. and to A. B. Rowzier, Providence, S. C., to build a branch from Seals Sid-ing, S. C., to Rose Hill, 11 miles.

**OCLLA SOUTHERN.**—An officer writes that this company has projected an extension from Rochelle, Ga., north to Macon, 80 miles.

**ONEIDA & WESTERN.**—An officer writes that the contract let to A. M. Cook, Oneida, Tenn., calls for building a section of 15 miles. The company plans to build from Oneida, Tenn., west along Pine creek and White Oak creek, thence northwest to Albany, Ky., 48 miles. The maximum grades will be 2 per cent., and maximum curvature 12 deg. There will be seven small steel bridges on the line. The company expects to develop a traffic in lumber and coal. O. H. Anderson, president, Harriman, Tenn., and R. J. Moscrip, chief engineer, Oneida. (November 14, p. 939.)

**OTTAWA, NORTHERN & WESTERN.**—See Canadian Pacific.

**RIVIERA BEACH & WESTERN.**—An officer of this company, which operates a line from Riviera, Tex., east to Riviera Beach, 10.7 miles, writes that an extension has been projected from Riviera, west to Falfurrias, 25 miles. Steam is used as the motive power for freight traffic, and gasolene motor cars for passenger traffic.

**SOUTH ONTARIO PACIFIC.**—See Canadian Pacific.

**THESSALON & NORTHERN.**—See Canadian Pacific.

**TILSONBURG, LAKE ERIE & PACIFIC.**—See Canadian Pacific.

**WEST VIRGINIA & SOUTHERN.**—An officer of this company, which operates a coal road from Marmet, W. Va., to Kleybolte, five miles, with a branch from Hernshaw to Charlmore, 1.5 miles, writes that surveys are now being made for an extension from Hernshaw for one mile.

### RAILWAY STRUCTURES.

**CHICAGO.**—The Chicago & Eastern Illinois is building a new office building for the chief engineers, claim agents and a part of the accounting forces, at Sixty-sixth street and Union avenue.

**DALLAS, TEX.**—The Texas railroad commission has authorized an issue of \$2,000,000 of bonds by the Union Terminal Company, to be used in the erection of a new union station for all roads entering the city and it is announced that a beginning of the work will be made on December 1.

**NORRISTOWN, PA.**—The Pennsylvania Railroad has given a contract for the reconstruction of the bridge at Norristown to L. H. Focht & Son, Reading, Pa. The contract for the bridge over the Allegheny river at Kiskiminetas Junction has not yet been let.

**BALTIMORE & OHIO.**—Charles A. Peabody, president of the Mutual Life Insurance Company of New York, and John G. Shedd, of Marshall Field & Co., Chicago, have been elected directors of the Baltimore & Ohio, succeeding John P. Green and Joseph Wood, retired, who represented the Pennsylvania.

**BUFFALO & SUSQUEHANNA RAILROAD.**—The reorganization committee of the first refunding 4 per cent. bonds has agreed on a plan of reorganization. This plan provides for the exchange of 4 per cent. bonds for \$700 in new first mortgage 4 per cent. bonds, \$300 in new 4 per cent. preferred stock, \$150 in new common, and \$20 in cash for each \$1,000 bond. About 90 per cent. of these bonds are deposited with the reorganization committee. Preferred stockholders pay 10 per cent. in cash and receive \$100 in new first 4 per cent. bonds, \$200 in new 4 per cent. preferred stock and \$300 in new common stock for each \$1,000 of old preferred. There is about \$4,000,000 preferred stock outstanding.

**ILLINOIS CENTRAL.**—The meeting of the stockholders to pass on the question of authorizing a refunding mortgage to cover the lines south of the Ohio river for \$120,000,000 has been postponed to November 21.

**KANSAS CITY, MEXICO & ORIENT.**—The various interests, including the security holders of the construction company, have agreed to submit to Judge Pollock, in the United States district court, a plan of reorganization.

**NATIONAL RAILWAYS OF MEXICO.**—The \$13,000,000 6 per cent. notes which matured on November 17 were paid principal and interest in accordance with the arrangements made in June when \$26,730,000 6 per cent. 2-year notes were sold. The next maturing obligations of the National Railways are \$801,900 interest due on December 1 on notes. Following this there is \$1,910,000 due in January as interest on the 4½ per cent. bonds. No announcement has been made as yet of the arrangements for taking care of these interest payments.

**NEW YORK CONNECTING.**—The Public Service Commission of New York, First district, has approved the issue of a mortgage of \$30,000,000 and the present issue of bonds to the extent of \$11,000,000 under that mortgage. The bonds are to run 50 years and to bear 4½ per cent. interest per annum. They are to be sold at not less than 91 per cent. of par value, and the discount is to be amortized during the life of the bonds. The proceeds will be devoted to the payment of construction expenses, including the refunding of short-term notes made for the purpose of raising money to defray the cost of work already done. The New York Connecting Railroad is owned jointly by the Pennsylvania and the New Haven, and is engaged in building a railroad and bridge to connect the New Haven system at Harlem River station, New York City, with the Long Island Railroad.

**NEW YORK, NEW HAVEN & HARTFORD.**—The company has made arrangements to sell \$45,000,000 6 per cent. notes at 99½. the notes being payable within six months. From the proceeds of the sale of these notes the New Haven will have cash to pay the \$40,000,000 notes maturing December 1 and so be enabled to await the decision of the Massachusetts courts in regard to the issue of \$67,552,000 convertible debentures. The contract for underwriting the debenture sale has been extended to January 28, 1914.

**ST. LOUIS & SAN FRANCISCO.**—Judge Sanborn has authorized the receivers to issue immediately \$3,000,000 6 per cent. one-year receivers' certificates to pay preferred claims.

B. F. Yoakum, in his examination before the chairman of the Interstate Commerce Commission, described the plans that he had had in buying the various lines through the Southwest, including the St. Louis, Brownsville & Mexico. According to his statements, he had planned to have a through line running from St. Louis via Memphis and Baton Rouge along the gulf of Mexico to Brownsville and from there to Matamoras and down the coast to Tampico, and eventually to extend this line to Colon, on the Panama canal.

# Railway Age Gazette

PUBLISHED EVERY FRIDAY AND DAILY EIGHT TIMES IN JUNE, BY THE  
SIMMONS-BOARDMAN PUBLISHING COMPANY,  
WOOLWORTH BUILDING, NEW YORK.

CHICAGO: Transportation Bldg. CLEVELAND: Citizens' Bldg.  
LONDON: Queen Anne's Chambers, Westminster.

E. A. SIMMONS, *President.*

L. B. SHEERMAN, *Vice-President.* HENRY LEE, *Sec'y & Treas.*  
The address of the company is the address of the officers.

## EDITORS.

SAMUEL O. DUNN, *Editor.*

ROY V. WRIGHT, <i>Managing Editor.</i>	H. H. SIMMONS	E. S. FAUST
W. E. HOOPER	H. F. LANE	F. W. KRABGER
B. B. ADAMS	E. A. AVERILL	A. D. CLOUD
E. T. HOWSON	R. E. THAYER	GEORGE L. FOWLER
	A. C. LOUDON	

Subscriptions, including 52 regular weekly issues and special daily editions published from time to time in New York, or in places other than New York, payable in advance and postage free:

United States and Mexico.....	\$5.00
Canada .....	6.00
Foreign Countries (excepting daily editions).....	8.00
Single Copies .....	15 cents each

Engineering and Maintenance of Way Edition and four Maintenance of Way Convention Daily issues, North America, \$1.00; foreign, \$2.00.

Entered at the Post Office at New York, N. Y., as mail matter of the second class.

WE GUARANTEE, that of this issue 8,800 copies were printed; that of those 8,800 copies, 6,652 were mailed to regular paid subscribers and 245 were provided for counter and news companies' sales; that the total copies printed this year to date were 415,569—an average of 8,657 copies a week.

VOLUME 55. NOVEMBER 28, 1913. NUMBER 22.

## CONTENTS

### EDITORIAL:

Editorial Notes .....	1005
Papers on Locomotive Running.....	1006
The Interest of the Railways in Better Farming.....	1006
A Great Future for the New York Railroad Club.....	1007
*Baltimore & Ohio.....	1007, 1050

### MISCELLANEOUS:

Locomotive Runners Tell How They Run.....	1009
*New Line Over Wasatch Mountains, Utah.....	1013
Shop Output; by J. H. Tinker.....	1018
Clifford Thorne and E. P. Ripley on Possible Savings Under Government Ownership .....	1020
*Smoke Washing Plant at Englewood.....	1022
Modern Apprenticeship; by John H. Linn.....	1023
The Freight Rate Advance Hearings.....	1025
Foreign Railway Notes .....	1018, 1019, 1022, 1024

### GENERAL NEWS SECTION .....

\*Illustrated.

**A**N important point regarding maintenance costs of locomotives was mentioned in J. H. Tinker's paper on "Shop Output," presented before the Western Railway Club last Tuesday night, and abstracted elsewhere in this issue. He said: "We have been compelled to reduce our shop forces almost every year, and in a great many cases have closed the shops entirely on account of depression in business, and every time this is done we affect the efficiency of the organization." He is not the only superintendent of motive power who has had to face these conditions, nor is the Chicago & Eastern Illinois the only road that has practised this false economy. That such maneuvering to cut expenses is absolutely bad practice will be attested to by all mechanical officials. It not only interferes with the routine

of the work and bunches the repair work so that it is necessary to rush it through the shops, but it disturbs the equanimity of the workmen and disrupts the *esprit de corps* so desirable and necessary in all shop organizations. While there are no definite figures to show the ultimate loss from such practice, it is at best a proposition of "robbing Peter to pay Paul," with the chances that considerably more is being taken from "Peter" than is received by "Paul." Mr. Tinker also draws attention to the poor condition of the power when such conditions exist; this, of course, will materially affect the transportation department. While it is an easy method with which to obtain ready money, it is an expensive method when everything is considered, and it will be found, when closely analyzed, that an extremely high rate of interest is being paid.

**B**Y the untimely death of Interstate Commerce Commissioner John H. Marble the government and people of the United States lost a public servant of ability, industry, integrity, public spirit and special fitness for the official position which he held. His death is the more regrettable because he was barely entering on the period of his greatest effectiveness and usefulness. The death of Mr. Marble means that President Wilson will soon have three vacancies to fill on the Interstate Commerce Commission. There are various disturbing rumors as to the course the President will take in filling these vacancies. Every one of these rumors implies that he may use the appointments as spoils for rewarding political supporters or furthering what he conceives to be his political interests. One report, for example, is that he will appoint Governor Glenn of North Carolina to remove him as a candidate to succeed Senator Overman of that state, the President being anxious that Mr. Overman shall remain in the Senate. It is inconceivable that a president who professes and in the main has lived up to such ideals as has President Wilson, could use the commission as a political dumping ground or the appointments to it as means for promoting anything except the fair, constructive and salutary regulation of railways.

**T**HE evidence which has been introduced in the investigation by the Interstate Commerce Commission into the conditions causing the appointment of a receiver for the St. Louis & San Francisco is not of a character to hearten those who are engaged in efforts to improve the relations between the railways and the public. The evidence indicates that B. F. Yoakum, chairman of the Frisco, and others influential in its affairs acquired railway properties in the southwest and then sold them at a profit to the St. Louis and San Francisco company. It may be that those against whom these charges are made can successfully defend themselves, and it is earnestly to be hoped that they can. If, however, they have done what is alleged, they have violated sound principles of morals, if not also of law. Those employed by a corporation in an official or fiduciary capacity have no right, while continuing in that capacity, to acquire outside property and then use their official or fiduciary positions as a means for selling the outside property to the corporation at a profit to themselves. They are employed to make money for the corporation—not from it. And the moral obligation and duty of directors and officers of railroads are especially high. Mr. Yoakum was for a long time one of the most popular and highly-respected railway officials in America, and it is, therefore, especially unfortunate that he has put himself in a position where such charges can be made against him, and still more unfortunate if these charges are true. The trouble with such transactions as have been alleged in this Frisco investigation is, that they are not only wrong, but that the disclosure of them reflects discredit on every railway officer, and excites public hostility against every railway company in the country. It has been repeatedly said, and it is literally true, that most of the troubles of the railways have been brought on them by the indiscretions or downright offenses of their own man-



agers. It would seem that the experience of the past ten years should be sufficient to teach railway directors and officers the danger of betraying their trusts or even committing acts that may be construed as betrayals of them. But the desire for selfish or improper, or even dishonest, gain continues to be, in the railway as in every other business, a motive which in the cases of many men overwhelms the dictates of discretion, good sense or even honor.

#### PAPERS ON LOCOMOTIVE RUNNING.

TO tell the young locomotive runner the whole story of how to avoid the pitfalls that might get him into trouble when running a fast train cannot be done in a single page; and the prize article on this subject which was given in the *Railway Age Gazette* of November 14 is supplemented in this issue by a collection of others, which may be called second-prize articles. These are from enginemen on the Southern, the Pittsburgh, Cincinnati, Chicago & St. Louis, the Chicago, Burlington & Quincy, the Southern Pacific, the Great Northern and the Pennsylvania.

Believing that the reader will find it profitable to look at the engine runner's work from several different angles, we have selected from the papers received in this competition still others—seven or more—which we propose to print in a future issue.

Some of the papers now printed are abridged. On the main features of the subject—the importance of normal bodily and mental health; of always securing sufficient rest; of being free from anxiety; of putting the engine in good order before starting; of enforcing the closed mouth while the train is running; on these the writers are all agreed. Repetition is unnecessary, and from those papers which came in last these portions are cut out.

A number of essays have included complimentary references to the value of the *Railway Age Gazette*, which are warmly appreciated; and some have been accompanied by testimonials which the authors have received from their employers. These also have been read with much interest, but it has seemed best not to print any matter of this kind.

#### THE INTEREST OF THE RAILWAYS IN BETTER FARMING.

THE railways have a vital interest in the solution of the problems of soil fertility and of the development of better agricultural methods in general. Any increase in the volume of agricultural products not only gives them more traffic to haul from the farms to the markets, but means a corresponding increase in the transportation of goods from the cities to the farming communities. These are direct effects; and as the prosperity of a nation depends largely on its agricultural resources and their development, it follows that the direct effects on the material well-being of the nation as a whole resulting from an improvement in agricultural methods, and a consequent increase in production, will have a vast indirect effect on railway traffic incidental to the resulting general expansion in the volume of business.

Railways have long recognized this fact, and for many years have been among the most important factors in the movement for improvement in farming conditions. They have brought immigrants to this country to settle, distributed literature on proper methods of soil cultivation, sent demonstration trains to the communities along their lines in co-operation with the agricultural colleges, furnished free seeds and reduced rates on fertilizer, and even established demonstration farms. Yet all of this work, as well as that of a similar but even more extensive character that has been done by the Department of Agriculture, has merely scratched the surface, according to Howard H. Gross, president of the National Soil Fertility League. Mr. Gross ad-

ressed the Traffic Club of Chicago on this subject on October 30, taking as his text "The Decline of Our Food Supply and the Remedy," and his remarks included some severe criticisms of the methods that have been pursued by the government and by the railways. All these have been good so far as they have gone, he said, but all of them together are neither sufficient nor highly efficient. Whether or not his criticisms are entirely justified, no one will deny that a great deal more will have to be done to make the present campaign of agricultural education as effective as it ought to be; and certainly the problem is big enough and of sufficient importance to utilize the best brain power that can be enlisted.

Mr. Gross and the National Soil Fertility League, which now includes among its directors, officers and advisory committee such railway men as James J. Hill, B. F. Yoakum, W. C. Brown, H. U. Mudge and F. A. Delano, as well as other men of national prominence, are at present concentrating their efforts on bringing about the passage of the Lever agricultural extension bill, now pending in Congress. The object of this bill is to provide the best means for carrying to the farmer the best methods and practices as determined at the agricultural colleges and experiment stations. It would furnish means for maintaining in each agricultural county a skilled farm demonstrator who would be the representative of the extension department of the state college of agriculture, the expense to be shared equally by the state and federal governments.

Mr. Gross cites some striking facts as illustrating the imperative demand for an improvement in farming methods. The population of the country is rapidly outstripping the production of food supplies. We now consume 91 per cent. of the wheat we raise and 98 per cent. of the corn. Our exports of live cattle have declined 75 per cent. in seven years, while our imports of cattle during the same time have increased approximately 2,000 per cent. Our exports of dairy products have declined 72 per cent. We are facing the highest living cost in the history of the country, and it is likely to go higher. In ten years our population has increased 21 per cent., while our meat supplying animals have decreased over 30 per cent. If the present rate of increase of population continues, the question as to how the coming generation is to be fed may become a most pressing one.

The yield per acre of cereals in the United States is approximately 40 per cent. of the European yield. The reason, Mr. Gross said, is the attempt to farm too much land and the practice of growing two crops upon the same field at the same time, namely, weeds and grain. "Man per man the American farmer produces more than twice as much as his European contemporary, but he requires practically five times the area upon which to do it. If the American farmer will cultivate one-half the area and do it well, it will increase his total production and net him dollars where he now makes quarters." For years in this country the farmers have been robbing the soil of its fertility, and when a farm has begun to fail to produce enough to justify the labor the owner has moved to richer land in the west and repeated the operation. This process manifestly cannot be continued indefinitely. As Mr. Gross expressed it, "Agriculture is the world's greatest business and it is the only business that is not conducted as a business. The need is the application of established and well-grounded business methods; the application of science to the end that the largest and best returns may be had for the time and money spent; in other words, the farmer must bring to his aid the scientist and the expert, and by their aid re-direct his efforts on more efficient lines."

Mr. Gross' criticism is that the methods that have usually been adopted for educating the farmer have not been adapted to his needs; that bulletins have been written in a language he could not understand, and that the demonstration work of the railways has not dealt with conditions with which the average farmer

must deal. Railway men understand thoroughly that it is one thing to issue rules or instructions, and quite another to know that they are being learned and obeyed. The same thing is true of other kinds of educational work. Something must be done to see that the instruction is brought home to the man most in need of instruction, and to show him in ways that he will understand why it is to his own interest to follow the instruction.

The bill in which the league is interested means placing thoroughly trained agriculturists in every community and maintaining them at public expense to advise with the farmer and help him solve the problems of production and distribution. It is believed by those familiar with the plan that in a few years it would practically double the output of our farms, and give us a larger and less expensive food supply, while increasing the profit to the farmer, as well. James J. Hill is quoted as saying it is the most important work for agriculture that has ever been undertaken in this country, while former President Taft has expressed the opinion that it would do more good to more people than any other enactment since the Civil War.

#### A GREAT FUTURE FOR THE NEW YORK RAILROAD CLUB.

WONDERFUL possibilities lie before the railroad clubs, and particularly before the New York Railroad Club, if their energies are properly directed. Many of those present must have felt this strongly at the meeting of the New York Railroad Club last Friday when D. M. Brady reviewed its history and achievements, and when the annual reports were read showing a membership of 2,099 and a cash balance in the treasury of over \$14,000. This club numbers among its members many of the leading men in the various branches of the railway service in this country and in the railway supply and manufacturing industry. Moreover, these men attend the meetings and take part in the discussions when the subjects are of sufficient interest to warrant their so doing.

At no period in the history of our railroads were there so many complex and important problems which demand solution. Some of these are being given the necessary attention by associations which are specially fitted to consider them. There are many, however, which could be studied and discussed to splendid advantage by the railway clubs. The New York Railroad Club, the oldest railroad club in existence, as well as the largest and wealthiest, will miss a great opportunity if it does not become the most influential and effective organization of its kind from the standpoint of assisting in improving the efficiency in all branches of railway service—and this is a matter which should not be difficult of accomplishment with the remarkable and fertile resources which it has at its command. F. M. Whyte apparently had this in mind when he directed attention to the fact that the most successful and effective meetings of the New York Railroad Club were those which have been held in connection with the annual Electrical Night. These have been in charge of a special committee which has given considerable time and effort to preparing a thorough study of the question and of carefully arranging the program in order to bring out the most advanced practice and the best thought of the leading men in the field. Mr. Whyte suggested that equal care be given to the preparation and presentation of the papers and reports for each of the monthly meetings of the club. This might be done by the appointment of a special committee for each meeting, or possibly by placing the whole matter in the hands of a meetings committee which could select the different subjects so that they would be correlated, and then assign them to sub-committees if it seemed necessary or desirable. In the *Railway Age Gazette* of October 3, page 599, the suggestion of A. L. Humphrey, vice-president and general manager of the Westinghouse Air Brake Company, at a meeting of the Railway Club of Pittsburgh, was commented on. His idea was that the work of the railroad club would be far more effective if more definite aims and poli-

cies were followed in preparing the program for each year. He even went so far as to suggest that the Railway Club of Pittsburgh could make a record for itself if it was to select, for instance, the problem of welfare work on the railroads and discuss its various phases at several successive meetings. It appears that this recommendation is being carried out, inasmuch as the paper scheduled for this week considers the problem of workingmen's compensation. If the New York Railroad Club were to select, say, an important problem in connection with more economical and efficient railway operation, and would at successive meetings consider each of its various important phases from the standpoint of the different departments or branches of service interested, and if in connection with this it would follow Mr. Whyte's suggestion of having these different parts of the general subject worked up and their presentation and discussion arranged for by special committees, the club could undoubtedly within a comparatively short time make a position for itself which would command the respect of the railway world.

The great difficulty in the way of bringing its members to a realization of the importance of this is that its membership is so large that even with mediocre papers a fairly good attendance is assured, and even if no paper at all is presented, as was the case some time ago, the refreshments and the opportunity for social intercourse are to a certain degree satisfactory to many of the members. We do not question the value and importance of the social activities of the club; these afford valuable opportunities for the members to become acquainted one with another and for the interchange of experiences and opinions, all of which are beneficial. W. G. Besler, vice-president of the Central Railroad of New Jersey, brought out nicely the necessity for even a greater activity of the club along these lines. On the other hand, if more attention was given to the educational program, the influence of the club could be very considerably widened, with a corresponding satisfaction to a far greater proportion of the club membership.

#### BALTIMORE & OHIO.

WHILE the annual report of any American railroad which is keeping abreast of the times is a progress report, there are times in the history of a road in which a particular year marks the completion of a certain stage of progress. This applies to a marked extent to the report of the Baltimore & Ohio, for the fiscal year ending June 30, 1913. As Mr. Willard points out in his letter accompanying the report, all of the more important work authorized by the board of directors since July 1, 1909, has now been completed and placed in operation with the exception of the Magnolia cut-off.

In 1913 for the first time in its history, the Baltimore & Ohio earned from operation over \$100,000,000, the increase over 1912 being \$8,962,000, and total earnings amounting to \$101,556,000. The final net, however, available for dividends was \$13,382,000, or about half a million dollars less than the corresponding figure for 1912. And it is a rather striking fact that the net available for dividends was about a hundred thousand dollars more in 1909 than in 1913.

During these four years the gains in efficiency in the use of the plant, the betterment of the plant itself and the increase in gross revenue have been as great as on any railroad in the United States. The increase in gross has been over \$25,000,000, and yet the profit to the partners in this great enterprise was slightly less last year than in 1909. As an illustration of the gains in efficiency of the use of the plant, the average freight train load is of course the most commonly used and generally accepted measure. In 1909 the average train load, including company freight, was 452 tons, in 1913 it was 651 tons.

As evidence of the betterment of the plant \$42,003,000 has been spent for additions and betterments and \$42,502,000 for additional equipment. These great sums have been spent in pursuance of a

carefully thought out plan to strengthen those parts of the transportation machine which would help most effectively to increase the total output of the whole plant. In 1909 the plant was worked almost to the full limit of its then capacity with the equipment and methods then in use. Since then the number of engines has been increased by 16 per cent. and the tractive effort by 35 per cent.; the number of freight cars by 12 per cent., and the tonnage capacity by over 27 per cent.; the percentage of all-steel or steel underframe and steel center sill cars has increased from 39 per cent. to over 68 per cent. The freight density was 2,253,000 tons one mile per mile of road in 1909 and 3,212,000 tons one mile per mile of road in 1913; in other words, all of the great development that has taken place on the Baltimore & Ohio has been intensive development.

The question naturally arises as to why, with all of this great increase in facilities, in the use of these facilities and the effectiveness of the use, the owners of the property have not received their share of the property's growth in increased net available for dividends.

The principal reasons are, probably, in the order of their importance, increases in wages which include changes in the hours of service and waste expenditures compelled by full crew laws, a higher standard of maintenance and better and more expensive service. It is quite impossible without an exhaustive study of the detailed records of wage scales to make any estimate whatsoever

The Baltimore & Ohio operates 4,456 miles of road with 1,269 miles of second track and 179 miles of third track, with 2,931 miles of sidings. The very heavy freight density has been mentioned—3,212,000 ton miles per mile of road—and the passenger density of 181,000 passenger miles per mile of road. The average haul of freight in 1913 was 198 miles, or about four and one-half miles longer than in 1912, and the average revenue per ton per mile was 5.6 mills, a decrease of 0.2 mill from 1912. The revenue train load was 620 tons, an increase over 1912 of 65 tons. The percentage of loaded car mileage to total car mileage was 65.78 per cent. in 1913 and 65.46 per cent. in 1912. The average number of loaded cars per train was 24.39 in 1913, an increase of 0.65.

Of the total tonnage carried, which amounted in 1913 to 72,461,000 tons, and in 1912 to 64,704,000 tons, 5.55 per cent. was products of agriculture in 1913 and 4.95 per cent. in 1912; 65.59 per cent. products of mines in 1913, and 66.63 per cent. in 1912; and 16.81 per cent. manufactures in 1913 and 15.71 per cent. in 1912. All classes of commodities showed increased tonnage except live stock and products of animals.

The balance sheet shows the company in strong position as regards current assets. Cash at the end of 1911 amounted to \$11,665,000, which is more by \$2,402,000 than was on hand at the beginning of the year. There were no loans and bills payable at the end of the year and total working liabilities amounted

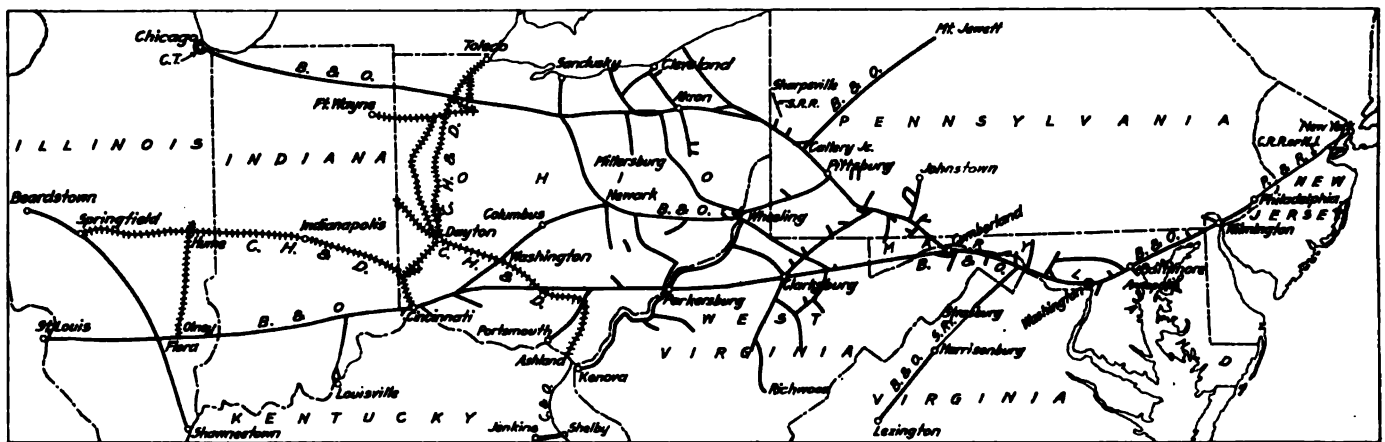

The Baltimore & Ohio System.

of the extent to which this element has been responsible for increases in expenses. We can, however, get some idea of the policy in regard to maintenance.

Maintenance of way and structures in 1909 cost \$9,695,000, and in 1913, \$14,020,000. Maintenance of equipment cost \$11,811,000, in 1909, and \$18,323,000 in 1913. The increases, however, have not been steady over the four years—the increase in 1913 over 1912 was an unusually large one. In 1913 the company spent \$3,124 per mile of road for maintenance of way and \$3,583 for repairs, renewals and depreciation per locomotive, \$797 per passenger car, and \$88 per freight car. This is distinctly liberal maintenance. The increase in maintenance of way in 1913 over 1912 was \$2,654,000, and in maintenance of equipment it was \$1,672,000. It should be noted, however, that of the total increase in maintenance charges, in 1913, \$576,000 was on account of expenses caused directly by flood damages and \$794,000 was incident to the reconstruction and revision of facilities.

In these comments on the showing of the company for 1913 more stress would be laid on the difficulties of operation due to the flood were it not that the *Railway Age Gazette* has already described in considerable detail this damage caused to the Baltimore & Ohio and other roads affected and the delays to traffic and the difficulties and expenses of operation. It should, however, be borne in mind in making an estimate of the road's showing in 1913 that this accident of the flood was a most important factor in the increase in expenses.

to \$14,878,000 at the end of the year, an increase of \$2,779,000 during the year, due almost entirely to traffic balances and vouchers in wages unpaid resulting, of course, from the larger business being done in June of this year as compared with June, 1912.

It should be noted in connection with the balance sheet that the president's report is unusually full and painstaking in its explanation of changes in the balance sheet that might not be readily understandable to the majority of the company's security holders.

The following table shows the principal figures of operation for 1913 and 1912:

	1913.	1912.
Average mileage operated.....	4,456	4,455
Freight revenue .....	\$80,194,490	\$72,465,544
Passenger revenue .....	15,537,078	14,754,912
Total operating revenues .....	101,556,132	92,594,323
Maint. of way and structures....	14,019,620	11,365,454
Maint. of equipment.....	18,323,210	16,651,534
Traffic expenses .....	2,026,274	1,950,599
Transportation expenses .....	37,274,397	32,751,234
General expenses .....	2,136,137	1,990,716
Total operating expenses.....	73,779,638	64,709,538
Taxes .....	2,960,905	2,783,195
Operating income .....	23,941,278	24,434,950
Gross income .....	29,153,484	28,777,843
Net income .....	13,382,111	13,941,452
Dividends .....	11,475,867	11,476,131
Surplus .....	1,858,384	2,421,927

# LOCOMOTIVE RUNNERS TELL HOW THEY RUN.\*

"Safety-First" on the Locomotive: Elements of the Problem  
as Viewed by Runners in the North, South, East and West.

## HOW TO KEEP A PERFECT LOOKOUT.

By M. C. GLENN.†

The locomotive runner should keep a perfect lookout. How is the proper habit acquired? I will not refer to my record, only to say that I am not ashamed of it. My experience of thirty years has been on the Richmond & Danville, and its successor, the Southern Railway. The first engineer for whom I fired I was with two and one-half years. He was a man who never talked any while running an engine. If necessary to ask a question of me, he did so, received an answer and that was the end of it. If I wanted to ask a question of him pertaining to the work, I did so but there were no arguments or conversations on his engine. He trained me not to talk while firing or running an engine. I will say that this habit has become so fixed with me that it seems to be a part of my nature.

There should be a perfect lookout from the cab. In order to obtain this it is necessary to train your fireman to keep the lookout from his side of the cab, on all curves leading to the left. Let him realize that at such points you have to see through his eyes; also that he is partially responsible for the safe movement of the train. In order that the fireman may accomplish this it is necessary for him to do his firing on straight line and curves leading to the right.

The proper habit is acquired by a few simple, practical rules, about as follows:

Don't talk to anyone while running a locomotive. This is a dangerous practice; you cannot carry on a conversation or argument and attend to your business as you should, while the locomotive is running from 25 to 75 miles an hour. The chances are that you will neglect something important. Train your firemen not to talk while the locomotive is running, not even to the flagman whom you pick up. Let the fireman realize that he is the engineer of tomorrow, and that it will be to your credit, as well as his, and the company's for him to be thoughtful, watchful and efficient. In order to reach this standard he must spend his time in constant thought; keep a constant lookout as far as is practicable for him to do. He must be alert, agreeable, willing to render all necessary assistance; even, in emergency, to do more than his duties require. Be perfectly sober both on duty and off. Now, if the engineer has trained his fireman along these lines surely the fireman has the right to expect the engineer to measure up to this standard also. Such being the case, there is a good team on that locomotive, and they will have few accidents or mishaps that intelligent forethought could avoid.

Quite recently I was going into a way station when two small boys were engaged in a frolic near the track; one pushed the other on the track not more than 10 ft. in front of the engine. The fireman yelled, "Stop!" My hand was on brake valve handle, it went into emergency, the boy's life was saved, and the company saved a lawsuit by the fireman's watchfulness.

I remember when I was running freight on one occasion a telegraph operator gave me a clear block, and allowed me to follow another train down the heaviest, longest and most crooked grade on my division in three minutes. The

boiler extended to back of cab; the conductor and the fireman were seated on the fireman's box. The man I was following stopped at the foot of the hill around a stiff curve to the left. The fireman or the conductor could have seen the train in ample time to avoid the hazard of an accident, but they did not. Why?—Talking. As soon as I got in position to see ahead the brake went into emergency on sand. The standing train moved forward excruciatingly slow, with my pilot under the platform of the caboose; but no damage was done. But what a close shave! And it could have been avoided if the fireman and conductor had been watching and thinking instead of talking. The result of this was an operator looking for a job.

I quote you a few rules, which I have successfully practiced for a good many years:

Don't assume any unnecessary risks. There are enough necessary ones.

Don't talk to anyone while running an engine. You might overlook some important duty. Train your fireman to the same practice.

Don't forget that 90 per cent. of the accidents occur at, or between switches.

And the majority of them occur at night.

You cannot be too alert approaching signals and switches and running through yards, especially at night.

Don't fail to train your fireman to be on the lookout, especially if track curves to the left.

Don't allow your mind to wander from your work.

Train yourself to think constantly of what you are doing.

Don't be thinking of the farms, the scenery, or the handsome animals that you see in the fields.

If you have family or other troubles do not take them on your engine.

Don't go out unless you are physically and mentally qualified to go.

Don't forget that the brain has to be impressed by what passes before. Many objects pass before our eyes which we do not see; therefore, the necessity for constant thought of our work.

Don't get angry or worried, as the anger or worry will occupy your mind in the place of something more important.

Don't be grouchy with your fireman. Be pleasant and agreeable.

Don't forget that you are a promoted fireman.

Don't have the third man in the cab if you can avoid it. He will want to talk, or do something, to attract your attention; and that is dangerous on a running locomotive.

## ADVANTAGE OF BEING ALWAYS ALERT.

By FRANK HAMILTON.

In twenty-four years' experience as an engineer on the Beardstown division of the Chicago, Burlington & Quincy, I have never had a wheel off the track nor pulled out a draw bar. I have never cost the Burlington Company one cent for repairs by accident.

First and foremost I always have my rest before going on the road. This I consider the most important feature as by following this rule my mind is always clear and all my senses are on the alert to discover anything out of the usual run. To illustrate this I may be permitted to cite a few examples. One very foggy night, in the days before our block signals were put in service, I came to a town at which I expected to make the regular passenger

\*Articles contributed in response to the offer of a prize which was published in the *Railway Age Gazette*, August 15. The article which won the prize, by Edward F. McKenzie, was published November 14.

†Mr. Glenn is an engineer on the Southern Railway and lives at Greensboro, N. C. He began locomotive service in 1884; fired for three years and six months, and then was a freight runner until 1902. Since 1902 he has been in the passenger service.

stop; and just after shutting off my engine I heard another engine slipping. By prompt action with both the air and the reverse lever I succeeded in stopping my train before striking the other train, which had been pulled by to back in. Nothing could be seen and it was the sense of hearing alone that saved my train in this case.

Of course it is taken for granted that engineers are strictly sober, as in no case could good results be obtained if men were even partly under the influence of liquor. In another case, caused by a lap order, I saved trains from collision by noticing the reflection of a head light on the outside rail of a left hand curve around a high bluff. An instantaneous thought flashed the conviction that nothing but a headlight could make light enough to cause a reflection so strong, in such a place; and the result was the escape from a very bad head end collision.

In one more case I noticed, on my going trip, that a stone quarry was shut down and not working. On my return trip I saw smoke just where the quarry was located about a mile ahead from where I was, the quarry being around a curve. Instantly I knew that something was wrong and immediately stopped my train. Before I had fully stopped I could see an approaching freight train, through a break in the timber; and before they had rounded the curve I had my train backed up about half a mile to a place of safety. In none of these cases could I have prevented the impending accident had I not been on the alert, with a clear head; which is the case only when a man has had sufficient rest.

In addition to my rest I make it a rule that all my own personal affairs (troubles and cares) shall be left behind and never taken with me to my work. This is another point which is very essential, and should be lived up to. When on my engine I am an entirely different man and know nothing but the business at hand.

I aim to obey all instructions, run through the yards under control and know the way is clear, taking no chances on switch lights.

The weather conditions must be watched for heavy rains which may cause washouts, and for hard winds, one of which once blew a coal chute across the track ahead of me. I had no warning of it other than evidence of the hard blow by limbs of trees, etc.

I make no repairs while engine is in motion nor do I permit any one to talk to me, as this diverts attention from the duties in hand. My fireman and I are friends, off the road; but while at work we are only engineer and fireman.

#### EXPERIENCES AND PHILOSOPHIES OF A PAN-HANDLE ENGINEMAN.

By JOHN BRUCE,

Engineman, Pennsylvania Lines West of Pittsburgh.

"To err is human"; and though the desire and ambition of every engineman may be to make a perfect record, sooner or later he arrives at a "circumstance" where he will have to admit that he made a mistake, if not a blunder.

The writer ran an engine on the Pennsylvania Lines West of Pittsburgh for 9 years and 8 months (and does yet for that matter), striving after the ideal; and then got disciplined because for the first time he depended on somebody else to keep track of passing trains, while he was busy doing necessary work on his engine on a side track. Moral: Don't depend on somebody else.

Another case: After brakes were tested at a terminal, a trainman, hearing air leaking between engine and first car, uncoupled air hose. After placing a piece of paper between the gaskets he recoupled, but forgot to open angle cock on the rear of tender. This might have ended disastrously, but fortunately the train was stopped by reversing the engine, on a favorable grade. Another case: An engineman made a practice of having his engine cut off at a certain point to take water. The writer happened on the run one day; and

on arriving at this same water station the trainman shut both angle cocks preparatory to cutting off the engine. Finding that water was not needed, he recoupled, but forgot to open one angle cock. This resulted in a narrow escape from side-wiping a passenger train, there being no air to stop the train at a clearance point on a siding. In both this and the preceding case the error was committed without the engineman's knowledge. Neither of these dangers is likely to happen to me again, the experience having taught me how to guard against them; namely, when train is stopped, to prevent any tampering with angle cocks, leave the brakes set until ready to proceed. If any angle cocks are left closed the train cannot be started. This has been found necessary on returning excursion trains at night, such trains having almost always a few unruly passengers who have been imbibing and who take delight in malicious mischief. One of these, on such a train, opened a conductor's valve in the toilet room, while we were speeding along at a 50 miles-an-hour pace. Judge of the effect of the application of the high speed brake from the center of a 15-coach train!

Another case: In order to make a flying switch (or swing) of some passenger coaches the release cock was used to bleed them. Trainmen, being short of time, forgot to close the cocks, and on the return trip had a serious collision with another passenger train, not having air to stop with at a meeting point. In this case the trouble was undiscovered because brakes were not tested. You never can tell what the other fellow is going to do. Of course the observant engineman might have discovered from the action of the air pump that something was wrong, if his mind was not overcrowded.

The old axiom, "Eternal vigilance is the price of safety," is exemplified every day in locomotive running. A perfect lookout is much to be desired, but how is this to be maintained in fog, at night, or during storms? Two-thirds of my 20 years' running has been at night. Fast trains are expected to make schedule speed when motive power is in proper condition, and when the road is kept clear of inferior trains. The only difference between clear and foggy weather to the engineman is that in fog he must keep close tab on landmarks and the physical characteristics of the road. . . .

The engineman must be familiar with all things pertaining to his calling and be composed in mind while on duty. Modern railroading, the 200-ton engines, steel cars, and automatic signals have changed conditions very materially. It is now, more than ever, a serious business, especially on the head-end of an express train.

It is possible to get in wrong, even when one believes he is attending strictly to business. I once ran by a red block, at full speed, mistaking the signal of an adjoining track for my own; and this is how it came about (and, mind you, I never learned the cause for several months; not until it nearly happened to me again). One winter night I was on my feet in the cab with side windows and back door closed. I approached a signal bridge at an interlocking on which were two masts, each having two blades. These two masts were identical in every respect. When standing in the cab, my line of vision was through the top of the glass in the front door. This portion of the glass happened to be defective, having slight waves or ridges which, at that time, I attributed to frost. The effect of this actually reversed the signals. A white light appeared above a red one for my track, and two red ones for the next track. Months afterward, under the same conditions (but in summer instead of winter) I got the same effect, but I had just previously looked out and had found the signals in proper condition and I was, of course, startled to find them suddenly thrown against me. Sticking my head out of the side window again I was relieved to find it an optical illusion. You can rest assured that that glass was missing when the engine arrived at the roundhouse. To summarize: The engineman's mind, while on duty, must

be free from anything akin to anxiety or worry. It goes without saying that alcoholic stimulants must be eliminated. As a business proposition, no railroad company can be expected to take chances with any man that is even liable to deaden his brain or dim his vision by such indulgence. Personally, I believe even smoking should be prohibited on engines in fast passenger service. Not infrequently have I leaned back in the cab to confer with the fireman about some object we were approaching at a 50-mile clip (invisible on the right side at the time) only to find him busily engaged in trying to light a pipe or toby. On account of the great draft of air in the gangway this consumes considerable time (and several matches), and at a critical time is dangerous. Self-preservation, one would think, ought to teach the danger of such inattention; but here, as elsewhere, familiarity breeds contempt. This is a case where two things cannot be done together rightly. A few seconds' time on an express train may mean life or death—as I could show had I the space.

The runner must leave all personal, family or business affairs at home, devoting all his attention to the trip he is engaged on, if he would keep out of trouble. Even a toothache may be enough to divert his attention momentarily so that he will fail to notice the absence of a light at night (signal otherwise in proper condition) and he be adjudged "technically guilty," as the writer once was.

He should form a habit of inspecting his engine when oiling around (if engines are pooled) before the trip. This will save him much trouble. The writer has by this method found broken frames, loose tires, broken flanges, partly broken springs and hangers, missing center pins of engine truck, loose eccentrics and pins and drivers loose on axles. Any of these, under favorable circumstances, might cause disaster. He should watch the air gage like a hawk, to be sure he has the necessary stuff to stop with; anybody can get 'em a going.

The engineman should train his fireman to arrange his other duties so as to keep a lookout on all curves on left side while track is temporarily invisible to the engineman. He must live up to all rules, general orders and notices; must depend on himself in emergencies, and not let the conductor do all the figuring. He should handle his train at all times just as if it were an officials' special. Nowadays the traveling public displays wonderful knowledge of railroading, and passengers are unsparing in their criticism when you make an extra "splurge" with the air, going into a station.

On single track the engineman should not proceed until he clearly understands the orders, what his rights are under the rules, and knows exactly what he is to do. He must learn to think and act quickly, keeping his mind (as stated above) on the particular trip engaged on; not tomorrow's nor last week's, but this one, and this only. He should form a habit of doing everything in a certain order, predetermined, and proved by experience to be the best.

He should be keenly alert at all times. Even his nostrils will tell him, where vision is impossible, whether it is a hot pin, a driving box, the ashpan, the lagging or a dragging brake that he smells. Each has its own peculiar odor. Don't be reckless. No officer will tolerate this. Much of the so-called recklessness in speed is largely due to the innate desire in man to excel.

In short, to make an ideal record an engineman must always be on the job, be a whole man, at one thing at a time, realizing that he is a cog in the wheels of the great modern transportation machine. Absent-mindedness or mind-wandering is absolutely fatal to success.

Fellow-enginemen: This is a critical time in the history of American railways, subjected as they are to much adverse and often foolish legislation, and it behooves every one to do that (to use words of St. Paul) "which is your reasonable service."

## REAL LIFE IN THE LOCOMOTIVE CAB.

By W. C. AIREY,

Locomotive Engineer, Coast Division, Southern Pacific Company.

My thirty years' experience—four years as fireman, and 26 as engineer (15 on passenger and 11 on freight) has been on four different roads; the Denver & Rio Grande, the Chicago, Peoria & St. Louis, the Rock Island and the Southern Pacific. The beginning was through the black canon of the Gunnison, where rock and land slides were frequent. This is where I formed the habit, through necessity, of keeping a vigilant eye on the track ahead. The road was new, and we scarcely ever got through this canon without finding one or more boulders on the track, and I have many times been able to stop only a short distance before striking them. The time on some runs was fast, and after several bad wrecks the management conceded that the engineers should use their own time and judgment in going through this canon. After that there were very few wrecks. We always carried giant powder on the engine with us, so, if the boulders were too large to roll off, we would blast them off. You can see that necessity, the mother of invention, compelled us to keep our eyes on the track ahead. And this is the only place I ever worked where the strain of watching ahead hurt my eyes or made my head ache. On other divisions and other roads I found I could, with perfect safety, watch ahead by glancing at the block signals (which should be in line with vision and no higher than cab window), then at the track, then for possible flags or road crossing signs and at my watch. In fact a well trained engineer can see one or all these things at a glance. But to insure perfect safety, he must have a fireman that he can depend upon to attend to the water and do other things in the cab, so that he can give his whole attention to the track ahead.

Then, after all is said and done, an engineer must train himself to keep his mind on his work. When he goes over a section of road every day and finds everything O. K., he is apt to think it will always be that way, and allow his mind to wander—thinking of other things. If these things are of vital importance to him, he can even pass a block signal against him, or a yellow flag, and not see it. So for absolute safety he must learn to keep his mind on his work, and keep constantly in mind the possibility of danger ahead. Surprise tests are undoubtedly good to help him do this if they are given fairly and with good judgment; but if they are unfair and made by unscrupulous men without judgment, as I have seen some given, then they are a detriment.

Some time ago while on a fast run I let my mind wander from my work, and I passed a block signal near a station where a gang of section men were at work. I no more than got past the signal, when I came to myself. I could not then determine whether it was for me, or against me. When I got to the end of my run, I found that several trains ahead of me had flagged through the block which the signal governed. That made me so sick that I had to go to bed. To think that I should allow my mind to wander to such an extent as to pass a danger signal like that! This was on double track, and it turned out that the signal had been out of repair; but it was finished just before I reached it, and it was clear. But the experience taught me the lesson, to keep my mind on my work while on duty.

In my younger days as engineer, while on the Denver & Rio Grande, I left Gunnison one day on a freight train at 10 a. m., with a clearance card, but a time-table meet with a passenger train at Parlin, eleven miles east. I entirely forgot about the meet. The conductor and the rest of the crew may not have forgotten the meet, but they evidently did not keep track of the time, for I had no word from them. As I rounded the curve coming to the station I saw the passenger train standing there. I was about a minute on their time. At a glance I took

in the situation and got stopped so as to head in on the siding. Nothing was said about it, but it changed my whole life; for it was a close call. I had been playing poker all night the night before, and my mind was so clouded I couldn't think about my work or anything else. I concluded I would either give up running an engine, or playing poker. I gave up the latter and have never played a game from that day to this. A man cannot stay up all night and lose his rest and then be a safe man on an engine.

I once had a close call by taking a handful of orders from the conductor and pulling right out, reading them running along. No engineer should do that.

If in pulling a high speed train an engineer finds his brakes, for any reason, not holding well, and he sees a distant signal against him, or any suspicion that he may have to stop quickly, he should act immediately on his judgment and apply the brakes in the emergency (that is what the emergency is for).

I was once pulling a special official train from Springfield, Ill., to St. Louis. I was not thoroughly familiar with the signals from East St. Louis to the union station over the Eads bridge, so, before leaving, I sent a message for a pilot to pilot me over the bridge. It would cost the company \$2. When I got to Litchfield, the superintendent of motive power and machinery, being on the train, came over and jacked me up for it, saying for me to go it alone; that he knew I could get through all right. I consented; but the nearer I got to the bridge the more it worried me. As luck would have it, when I got to East St. Louis I saw a Terminal fireman strolling about, and I asked him to ride over with me, which he did. I have thought many times since, what a foolhardy thing to do, to take such a chance!

But with all my 30 years' experience on an engine, I have never had a serious accident.

#### MAIN POINTS IN THREE PARAGRAPHS.

By H. F. GEORGE.\*

I have been running a locomotive for some eighteen years and it was a long time before I was able to give the track ahead my full and undivided attention, which is absolutely required if you are to be successful in not colliding with preceding trains, not running into slides, etc.

To keep your mind on your work, not letting it wander, requires persistent effort, and practice. When I reach the roundhouse preparatory to starting on a trip, I make it a practice to drop everything from my mind except that pertaining to the railroad. Have I sickness in my family; have I financial worries; all are forgotten, till the end of my trip. I think of nothing else, I talk nothing else. After the trip is actually begun, the fireman is not permitted to speak to me on any subject except the matter in hand; no stories or anecdotes. If other persons are riding on the engine, they are not permitted to talk to myself or the fireman. Should the lubricator or any other fixture in the cab require my personal attention, it is not given while rounding or about to round a curve; I wait till I reach a straight piece of track; then, seeing everything clear, I do that which is necessary, getting my attention back to track before I have reached the place where my line of vision failed to extend before.

I think the one greatest cause of accidents is to be found in the engineer letting his mind wander to other subjects during the trip. I have known of many cases, have experienced them myself, where an engineer has disregarded a signal, while looking squarely at it. He sees it, but without the necessary sensation reaching his brain. Maybe the sensation finally reaches the brain in time to prevent an accident, and maybe it doesn't.

One has to continually fight against the tendency of the mind to wander. Continued effort, and the afore-mentioned practice

\*Mr. George is an engineer on the Cascade division of the Great Northern, where he has been since 1906. Before that, for 14 years, he was on the Cleveland & Pittsburgh division of the Pennsylvania Company's lines.

of dropping all other subjects from the mind on reaching the roundhouse will in the end win out, and you can make your trip with your mind free from home and other worries. Thus you will help to cut down the number of accidents to the minimum.

#### LOOKING OUT FOR THOSE WHO DO NOT LOOK OUT FOR THEMSELVES.

By GEORGE W. ROSE.

I entered the service in 1864 at the age of fifteen as a brakeman on the Bellefonte & Snow Shoe, and remained there until 1868, when I became brakeman on the Eastern Division of the Philadelphia & Erie, controlled by the Pennsylvania. I went to firing in 1869, and was promoted to engineman in 1872 on the Sunbury Division. I hauled freight until 1877, when I was given a passenger run, and outside of a few changes in the time table I am hauling the same train today. [After dealing briefly with general considerations, Mr. Rose goes on as follows:]

How about the fatal grade crossing accidents that take place all over our country? On double track, where vehicles or pedestrians on foot are waiting for a long freight train to pass, as soon as the caboose clears they rush over, not thinking of danger; the express train comes along at a high rate of speed and knocks the life out of them. Cannot some of these accidents be avoided? Let us consider it part of our duty to take notice where people are waiting to cross and motion or call to them. This may be the means of saving many lives.

Now I have a few words to say to enginemen on fast trains. At points where you do not have a good clear view, or where a person would be likely to step on the track in front of you, keep the whistle cord in your hand. I have run many a mile with the whistle cord in one hand, and at times the brake valve handle in the other. The runner of a fast train passing a long freight train moving in the opposite direction at a public road crossing can usually judge if he will pass over the crossing before the caboose of the freight train gets there. If you have any doubt about it, slow down and give the careless pedestrian a chance for his life. The little time that is lost can be made up, if necessary; but we cannot make up for lives lost, or console the widow. If you cannot calculate the distance, then open the whistle and keep it open until crossing is passed. In many cases of this kind where we are taken on short notice the whistle is more valuable than the air brake. I have known many cases where, I am sure, lives have been saved by the engineman having the whistle cord in his hand at dangerous points or in passing trains.

Don't do as I did on one occasion years ago. I took an extra engine out and failed to examine the whistle rope on top of the cab. I went all right for about fifty miles, when a man stepped on the track ahead of me. I got one blast and the rope broke; but that one blast saved the man's life.

I notice that sometimes where trains have pulled in on sidings, and are waiting to be passed by a fast train, some of the crew are killed by the very train they are waiting for, and which is expected at any minute. I believe that often this is due to too much noise. In such cases engines should be kept as quiet as possible. They should not be allowed to blow off. Keep the cylinder spiggots closed, the blower valve closed, and throw out as little smoke as possible. And there is yet one more important thing. The express comes in sight. "Now boys, get her ready, so we can pull out as soon as the express passes; put on the blower." The fireman gets down and stirs up the fire, and up goes a great cloud of smoke, which covers up the block signal arms. Now that is a very important train, and it must reach its destination on time. The engineman is straining every nerve and has had a clear distant signal; but we have cut off his view of the home signal. So he must slow down, if not come to a full stop; or else take the chance of entering the block on the strength of the distant signal, not knowing the home is clear or not. We must not think of ourselves alone; but of others as well.

# NEW LINE OVER WASATCH MOUNTAINS, UTAH.

D. & R. G. Has Completed a Road Down West Side to Avoid Heavy Grades. Also Made Changes in Locomotives Used.

The Denver & Rio Grande placed in operation a new double-track line down the west slope of the Wasatch mountains, between Soldier Summit, Utah, and Tucker, on a 2 per cent. maximum grade to replace the present 4 per cent. line on November 16, 1913. This 4 per cent. grade was the heaviest on the main line of the Denver & Rio Grande, the maximum grade crossing the continental divide over Tennessee Pass being 3 per cent., and so far as is known, was the last 4 per cent. grade of any length on any transcontinental main line. Soldier Summit lies on the main line between Denver and Salt Lake City at the crossing of the Wasatch mountains at an elevation of 7,445 ft. This portion of the line from Salida, Col., via Marshall Pass was built as a narrow gage road in 1881-83. Until 1890 this narrow gage line over Marshall Pass formed a part of the transcontinental line and passenger trains fully equipped with narrow gage standard and tourist sleeping cars were operated between Denver and Salt Lake. In 1890 the Denver & Rio Grande widened its narrow gage line over Tennessee Pass and extended it from Glenwood Springs to Grand Junction as a standard gage line. In that same year the Rio Grande Western was widened to standard gage west of Grand Junction. When this work was completed the standard gage line over Tennessee Pass was made the through transcontinental route.

## OPERATING CONDITIONS.

The physical characteristics of the old line between Soldier Summit and Tucker were probably not equaled, at least with respect to gradients, on any main trunk line in this country and a description of conditions of operation are essential to a complete understanding of the causes leading to the construction of the new line. The present operating division extends from Helper, Utah, to Salt Lake, a distance of 114.5 miles. The ruling grade westbound is 2.4 per cent. for 12 miles from Helper to Kyune, and 1 per cent. for the remaining 12 miles to Soldier Summit. From this point to Salt Lake there is practically no adverse grade westbound. Eastbound the maximum

the Missouri Pacific on the east and the Western Pacific on the west, it is benefiting from the increased traffic turned over to it by these connections at Pueblo and Salt Lake. At the present time an average of two through time freights in addition to dead freight trains are now handled each way daily. However, the largest proportion of the traffic moved over the Utah division consists of coal originating at Castle Gate and on several branches in the vicinity of Helper, and coke from

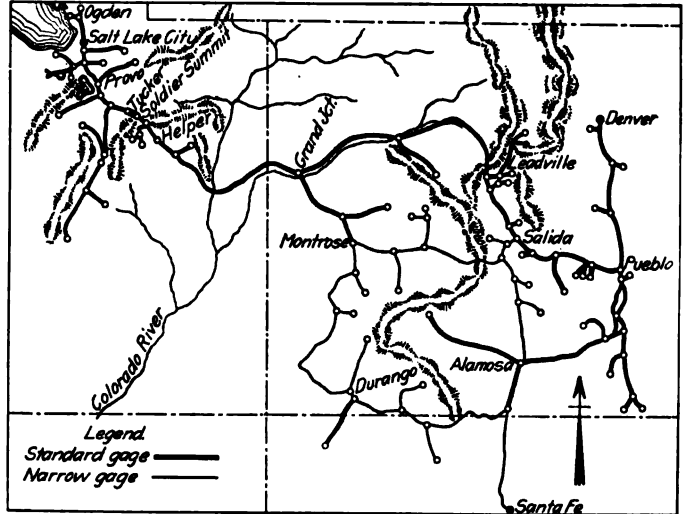

Denver & Rio Grande Lines.

Sunnyside. A portion of this coal traffic is turned over to the San Pedro line at Provo, but the most of it moves west and northwest of Salt Lake almost to the Pacific coast while the coke goes primarily to Salt Lake valley smelters and to the smelters at Butte and Anaconda. This traffic causes a correspondingly heavy return movement of empty cars. This total movement of

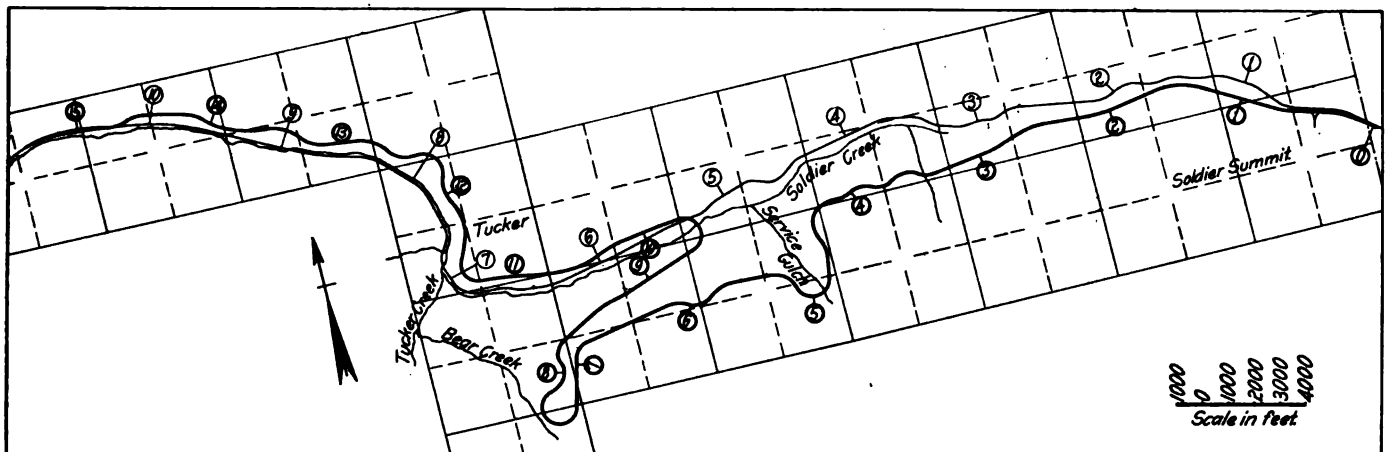

Map of New and Old Lines Between Tucker and Soldier Summit.

grade from Salt Lake to Thistle, 64 miles, is 1 per cent.; from Thistle to Tucker, 18 miles, 2 per cent., and from Tucker to Soldier Summit, 7 miles, 4 per cent. Double track has been provided from Salt Lake east 10 miles to Midvale; and from Thistle east through Tucker and Soldier Summit to Helper, 51 miles. The second track from Soldier Summit to Tucker was built in 1897, and from Tucker west to Thistle was completed this spring.

As the Denver & Rio Grande forms the connection between

freight averages about nine tonnage trains each way daily. The passenger traffic consists almost entirely of through transcontinental business and requires an average of four heavy trains each way daily.

The unusually heavy grade descending in the direction of the loaded car movement introduced the unusual condition that the limiting tonnage was that which could be brought down the hill rather than that which could be pulled up. In other words, the total train mileage was governed by the number of trains





year ago. Down grade, of course, the number of locomotives required for passenger trains remains the same. Also including extra trains from 15 to 25 per cent. more cars are handled per passenger train now than a year ago.

To illustrate the improved operation which has been made possible by reason of the adoption of the new Mallet locomotives and the application of the 8½ in. cross compound Westinghouse air pumps to the locomotives, the following figures regarding freight movement on the heaviest day, October 17, 1912, show similar improvement. From Tucker to Soldier Summit the moving of 105 loads and 195 empties, or a total of 8,771 tons up the hill required 14 trains with 37 engines. On the same day, 297 loads and 15 empties with a total of 15,447 tons were moved from Soldier Summit to Tucker with 15 trains and 15 locomotives. Using 8 of the Mallet locomotives now

LOCATION OF THE NEW LINE.

The second step taken to improve conditions at this point was the construction of a new line on a lighter grade. A detour line on a maximum grade of 2 per cent. compensated for curvature to replace the present 4 per cent. line partially compensated between Soldier Summit and Tucker was authorized late in 1912. The location of this new line presented several interesting problems. The 4 per cent. grade on the old line decreased to about 1.1 per cent. for three miles from Tucker west to the head of the 2 per cent. grade to Thistle. Several locations were made to eliminate this 4 per cent. grade, all of which connected with the old line at the foot of this heavy grade at Tucker. These lines necessarily doubled the mileage on the old line between the termini and developed up Bear Creek. The location finally adopted, however, took advantage



Loop Lines Opposite Main Line Crossing.

consigned to this work the same tonnage of 8,771 tons could be moved up the mountain in 9 trains with 25 engines. Likewise, the 15,447 tons could be moved from Soldier Summit to Tucker with 13 engines and 13 trains. It will be noted that this comparison indicated a saving of 12 engines and 5 trains eastbound and 2 engines and 2 trains westbound.

Until the abandoning of the old line a few weeks ago the usual arrangement of engines in moving a train up hill was to use one consolidation locomotive ahead, a Mallet in the center and consolidation in the rear. Five Mallets and one consolidation locomotive are stationed at Tucker, 10 consolidation locomotives at Thistle and 5 Mallets and 3 consolidation engines were held at Helper, this number, of course, varying from month to month with the traffic.

of this slack grade below Tucker. By adjoining the old line at the head of the 2 per cent. grade and continuing this grade to the summit the slack grade was absorbed by development in the general direction of the line so that the development at right angles was reduced and the total length of the line increased 4.42 miles instead of 7. As is to be expected where development is necessary to secure the desired grade, the curvature is increased—the amount in this case being about 950 deg. Even then 52 per cent. of the new line is tangent, the longest tangent being 3,220 ft.

The old line lay well down in the valley of Soldier Creek and followed practically parallel to this stream. Starting from the connection with this line four miles west of Tucker the new line climbs continuously up the side of the mountain on

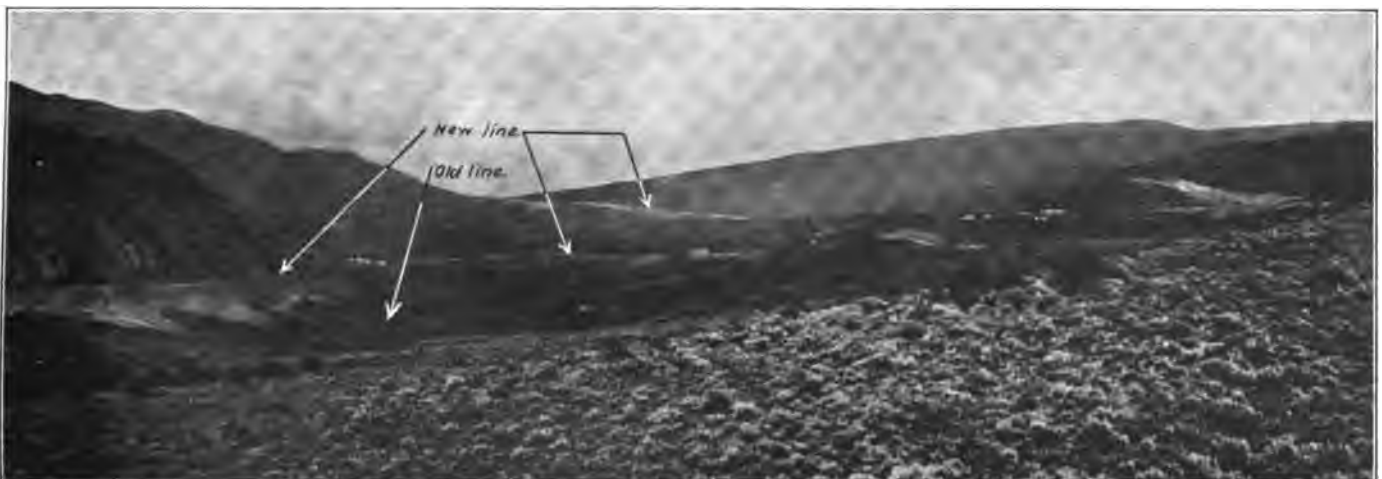

Looking East Over New and Old Lines from Bear Creek Loop. Digitized by Google

a 2 per cent. compensated grade, until opposite the foot of the 4 per cent. grade at Tucker it lies about 150 ft. above the old line. It crosses under this line two miles east of Tucker and then doubles back on a four mile development loop in Bear Creek. This loop contains over 230 deg. of curvature and at the end opposite the under-crossing of the old line is about 450 ft. above it. The new line then continues practically parallel to the old line, but higher up on the opposite side of Soldier Creek to a connection with the old line at Soldier Summit where 3,000 ft. of level grade is provided, cutting down the old summit elevation about 12 ft.

The new line is located with a maximum curve of 9 deg., and has only six curves of this degree, mainly on the loops. All curves are spiralled with a minimum length of spiral of 150 ft. The minimum length of tangent between reverse curves is 125 ft. Because of its position higher up on the hillside the new line is more favorably located with respect to washouts which are a serious menace in this country. The experience this past summer in the new cuts indicates that difficulty from this source will be materially reduced. The new line is 15 miles in length

labor conditions. At one time in June the entire work was shut down for several weeks because of a strike brought on by agitators of the Industrial Workers of the World. After this strike was lifted an entirely new force had to be organized to carry on the work. The resultant delay from this cause and the excessive amount of rainfall postponed the completion of the grading at least five or six weeks. Only a few teams were employed near Soldier Summit and very little station work was resorted to.

The rough character of the ground and the steep slopes made it very difficult to get such heavy equipment onto the work. The contractor devoted all of December and January, and a part of February to getting this equipment in, spending over \$250,000 on this item alone before the actual construction began. In one instance four steam shovels and six locomotives with cars, coal, concrete materials, etc., for use on miles 6, 7 and 8, were raised 325 ft. by means of a cable on a track 1,400 ft. long and laid on a 40 deg. slope. In another instance on mile 5, the contractor built an incline 600 ft. long and raised material 200 ft. in the same manner. As this equipment was all



Train No. 6 Eastbound on April 26, 1911, Ascending Four Per Cent. Grade with Five Engines Pulling Eleven Cars.

and is being built for double track. Upon its completion the old line will be entirely abandoned.

#### GRADING.

The amount of material to be moved on this 15 miles of line was estimated at 3,500,000 cu. yds., or about 233,000 yds. per mile, of which 33 per cent. was rock. Rock predominated on the lower five miles of the line, while the material encountered on the remainder of the line consisted largely of wash material with some stratified sandstone in the bottom of the cuts. Very little shale was encountered in the upper 10 miles.

The grading was all done by contract and was let without classification, but with a 500-ft. free haul clause. Because of the large amount of material to be moved in one season, 20 steam shovels and 48 locomotives were installed on the work, and at one time 15 of these shovels were working double shifts. The contractor employed an average force of 1,300 men all the past season and made an unusual record in handling this large amount of work in practically eight months in view of the character of the country and unusual troubles with weather and

brought in during the winter it had to be moved over the frozen ground. In one instance a shovel dug its way through the frozen earth for a mile to get in to this work.

Although grading was started to a limited degree in January, practically no progress was made until the middle of the following month. The largest amount moved in any one month was 572,000 yds. in May. The methods used were those generally adopted on work of this heavy character. A number of sidehill cuts were entirely shot out or "daylighted," but with this exception the material from the cuts was hauled into the fills. Switchbacks were freely used in getting from the cuts down on to fills, although trestling for the full height was used in a few instances. In two places cableways supporting dumping tracks were adopted for high fills, but were not successful on this work and were abandoned. Cyclone well drills and steam drills were used in rock work. As shown on the accompanying section of profile, the cuts and fills were generally heavy and relatively short. There are no tunnels on the new line, although one about 350 ft. long was originally planned on mile 7. However, after the character of the material at this point was

ascertained it was decided to take it out as an open cut. The maximum depth of this cut was 85 ft., and about 116,000 yds. of material was removed. Although gravity water supplies could have been secured for all the steam shovels, the fact that they were moved in during the winter prompted the contractor to pump from springs and creeks at convenient points rather than to incur the expense of constructing gravity pipe lines at that season. The grade is built for a uniform width of roadbed of

and no span openings were required. The largest opening was a 12 ft. arch for a roadway with a 4 ft. x 4 ft. box below to provide a passage for all except floodwaters. This culvert is 242 ft. long and was constructed in three sections, the upper two of which rest on rock and the lower on back-filled material. All of these culverts were included in the general grading contract and three-quarters of the masonry was placed during freezing weather, which continued at this altitude until May. Precautions were taken to heat all the materials by steam and the heat was kept on until the forms were removed.

Considerable trouble has been experienced at Tucker with muddy water for locomotive use for several years, and for this reason special care was taken in building the new line to secure a better grade of water. A reservoir with a capacity of 1,000,000 gals. has been constructed in Sleepy Hollow along the new line. To impound the water from the springs a dam with a concrete core wall has been built. An 8 in. gravity pipe line leads from this reservoir to a 50,000 gal. wooden tank and standpipe at the north end of a double passing track. A 6 in. pipe leads 1,600 ft.



Moving a Steam Shovel Up a Forty Per Cent. Incline.

35 ft. on fills and in cuts. Side shrinkage is added on fills to the extent of 10 per cent. of the height.

With two exceptions practically no trouble was experienced with slides, even though nearly all the work was on sidehills on steep slopes. In one instance the overburden on the rock slid out under a high fill at Tucker with no serious consequences other than that of increasing the yardage. The second instance was on the Bear Creek loop where in the large cut originally requiring the removal of about 176,000 yds., the material slid in when the cut was half completed, burying the steam shovel and causing the bottom of the cut to raise about 10 ft. on each side of the shovel. This difficulty was overcome by removing the material until it came to a position of equilibrium.

**OTHER CONSTRUCTION DETAILS.**

The 55 openings under the new line are all concrete culverts and boxes. As this line is located well up on the mountain side and practically at the summit of the range the drainage is small



Shovel Working in Cut on Bear Creek Loop.

farther to two other standpipes. Thus, while the leading engine stops for water at one standpipe the Mallet locomotive in the center of the train can cut off and take water at the same time.

The new tracks were laid with 90-lb. rail with oak ties on all curves over 4 deg., and tie plates on all ties. Gravel ballast secured 20 miles east of Salt Lake was provided. All rails for



Train No. 6 Ascending Four Per Cent. Grade with One Road Engine and a Mallet Pusher on July 10, 1913.

curves of over 4 deg. were curved in advance with a steam bender. Following the practice adopted in constructing the second track between Thistle and Tucker of providing a passing track for uphill trains every 5 miles, and for descending trains every 10 miles, a standard passing track 3,600 ft. long from head block to head block was built for eastbound movements at the south end of the new line and another five miles west of the summit, while double passing tracks were built midway between these two, at which point the water tank and standpipes referred to above are located. The grade was reduced below the maximum of 2 per cent. through all passing tracks on the new line.

With the completion of this new line the six-helper engines at Tucker with the necessary roundhouse and engine facilities and the station force were eliminated as the one helper engine put on at Thistle is able to assist a tonnage train to the summit. The complete air testing plant with car repairers and inspectors at Soldier Summit will also be unnecessary, as only the regular tests of air are made before descending the grade. This eliminates the present average detention of one hour to all freight trains westbound, which item alone is estimated as amounting to approximately \$2.47 per train for the dead time of train and engine crews. Likewise, the derail switches and their attendants are no longer required. The total saving in operating expense



Shovel Removing 100,000 yd. Slide on Bear Creek Loop.

by the construction of this new line is estimated to exceed several hundred dollars per day.

This line was built under the direction of J. G. Gwyn, chief engineer, and Arthur Ridgway, assistant chief engineer. L. B. Fuhrman, construction engineer, located this line and was in direct charge of construction. The Utah Construction Company, Salt Lake City, was the contractor on this work. We are indebted to all the above gentlemen and to W. S. Martin, general manager, and A. B. Apperson, general superintendent of the Utah lines, for the above information.

**FRENCH RAILWAYS IN TURKEY.**—In deference to the wishes of Russia and to the rights based upon the Russian Convention of 1900 with Turkey, the French railway concessions in Asia Minor will not include the extension of the Samsun-Sivas-Pinggan-Erzinghian line to Erzerum, but only to a point—Pekjaridj—some 50 miles northeast of Erzinghian. Pekjaridj was the point at which the railway from Trebizond was to join the projected line. The Pekjaridj-Trebizond section has now been postponed to a later date. On the other hand, the concession for the south-going section of the line from Pingan to Kharput has been extended as far as Arghana, and a concession has definitely been granted for a line from Arghana to Bitlis and Van. There is a projected German line going north from Nesibin, on the Baghdad Railway, through Diarbekr and meeting the French line at Arghana. A concession for a line branching westwards from the Samsun-Sivas-Railway has been granted, but the point of junction and the route have not yet been decided. It appears that the concession for a small branch line from Turchal to Takat has been abandoned.

### SHOP OUTPUT.\*

By J. H. TINKER,

Superintendent of Motive Power, Chicago & Eastern Illinois, Danville, Ill.

Unless some uniform method of comparing output can be obtained a fair comparison cannot be made between different railway shops. I believe the following items should be considered in rating the output of shops: The general lay-out of the shops and machinery. The number of men employed in all of the shops (average per pit). The number of pits operated. The average number of machines per pit. The amount of finished stock material. The facilities and method of handling. The class of repairs. The size or tractive effort of the locomotives. Organization and whether piece work or day work is used.

Taking the majority of these items for a basis to work from, I have prepared a statement showing the number of locomotives turned out of our shops at Danville, Ill., for the years 1912 and 1913, taking into consideration only classes 1, 2 and 3 repairs.

Month and Year.	MONTHLY EFFICIENCY OF OAKLAWN SHOPS.													
	Class number of repairs.				Tractive power in thousands of pounds. Class No. of repairs.			Total T. P. output per month.	Number of men employed.	No. of men per 1000 lb. T. P. output operated.	Number of pits operated.	Number of engines per pit operated.	Number of men per pit operated.	Number of men per engine output.
	1	2	3	Total	1	2	3							
Jan., 1912..	4	11	3	18	119	356	95	570	682	1.19	16	1.20	42.6	37.9
Jan., 1913..	1	5	10	14	32	118	297	447	607	1.35	15	1.93	40.4	43.3
Feb., 1912..	6	9	7	22	189	304	200	693	699	1.01	15	1.46	46.6	31.8
Feb., 1913..	2	9	6	19	50	332	197	569	622	1.09	15	1.13	41.4	36.8
Mar., 1912..	4	10	4	18	108	324	109	541	550	1.02	13	1.38	42.3	30.6
Mar., 1913..	1	8	8	17	25	206	281	602	602	1.00	14	1.21	43.0	35.4
April, 1912..	0	1	1	2	0	38	25	63	250	4.00	4	1.50	62.5	125.0
April, 1913..	5	6	6	17	156	200	183	542	668	1.23	13	1.30	51.4	39.3
May, 1912..	0	1	4	5	0	15	125	140	265	1.90	4	1.25	66.1	53.0
May, 1913..	6	5	4	15	181	199	105	465	585	1.26	14	1.07	41.8	39.0
June, 1912..	1	3	3	7	25	112	100	237	444	1.87	9	1.12	38.8	63.4
June, 1913..	7	4	7	18	251	149	300	700	620	0.88	16	1.12	38.8	34.4
July, 1912..	3	9	4	16	73	276	129	478	712	1.50	19	1.05	37.5	44.5
July, 1913..	6	5	11	22	183	169	457	809	750	0.92	22	1.00	34.1	34.6
Aug., 1912..	7	8	5	20	206	293	188	687	713	1.03	19	1.05	37.5	35.6
Aug., 1913..	6	11	8	25	191	409	383	983	819	0.83	23	1.09	35.6	32.7
Sept., 1912..	4	6	2	12	125	183	76	384	676	1.60	14	1.05	37.5	51.3
Sept., 1913..	4	8	13	25	113	269	495	877	825	0.94	23	1.09	35.9	33.0
Oct., 1912..	3	7	5	15	83	226	128	437	572	1.30	13	1.15	44.0	38.3
Oct., 1913..	..	..	..	..	..	..	..	..	..	..	..	..	..	..
Nov., 1912..	1	6	5	12	17	183	162	362	572	1.44	12	1.00	43.5	43.5
Nov., 1913..	..	..	..	..	..	..	..	..	..	..	..	..	..	..
Dec., 1912..	6	5	7	18	147	173	200	526	566	1.07	13	1.38	43.5	31.4
Dec., 1913..	..	..	..	..	..	..	..	..	..	..	..	..	..	..

Following is an explanation of our classification of repairs:

**Class 1.** New boiler or firebox complete, new flues, and general repairs to the machinery.

**Class 2.** Heavy repairs to the machinery, the flues reset, one-half of the side sheets, new front and back flue sheet, new crown or door sheet, tires new or turned.

**Class 3.** Light repairs to the machinery, flues new or reset, tires new or turned.

**Class 4.** Covers all repairs not included in Classes 1, 2 and 3, where the expenses for the labor and the material exceed \$125.

**Class X.** Covers accident repairs, and may be used in connection with Classes 1, 2, 3 and 4, or separately when the repairs made include the damaged parts only.

Any repairs made where the expenses for the labor and the material are less than \$125 will be considered "Running Repairs." New patches on the side of the flue sheet and new extension front ends are not considered Class 2 repairs.

I have not taken into consideration Class 4 repairs, yet we have turned out a number of this class of repairs where the cost would run \$600 to \$800 because of the engine meeting with an accident immediately after receiving general repairs and could not be classified otherwise, not receiving a new boiler, firebox, or flues. The average number of engines turned out of the shop for Class 4 repairs is about eight per month.

In analyzing the above statement of output at the Oaklawn

\*Abstract of a paper presented before the Western Railway Club at the November meeting.

shops, you will note for the month of August, 1913, an increase over the corresponding month a year ago of 25 per cent. (43 per cent. increase in tractive effort) with only 14 per cent. increase in men employed, 21 per cent. in pits operated, and 37 per cent. in engines per pit, with an increase of only a fraction of over 3½ per cent. in the shop payrolls. Ten or twelve years ago the average number of days for an engine on the pit in the back shop was from 15 to 20, but the engines were much smaller and carried less steam pressure than at the present time. Now we have heavy Mikado engines, and with the addition of heavy appliances, such as superheaters, etc., they will run from 20 to 24 days on the pit, as an average.

I believe a shop schedule or accounting system will increase efficiency. We have not tried it on our road other than to set a date that we anticipate the engine should be completed, painting this date on a board and hanging it on the engine, so that each foreman will know when the engine is expected to go out. We specialize our work as much as possible. The shops also get out all finished parts, such as driving boxes, shoes and wedges, flues, etc., for all roundhouses on the system where we have no machines. All repair parts are furnished from the Danville shops. Our back shop forces also handle repairs to all the stationary boilers, pumps, air compressors, etc., on the system, as well as derrick cars, Lidgerwoods, steam shovels, gravel spreaders, and center plows. In addition, all tools and other machinery are sent to these shops for overhauling. We repair at Danville all jacks, air tools, etc., for the entire system; in the statement shown above, we have included all men employed, while if we deducted such employees as handle this special work, the number of men per pit would be considerably less than that shown.

Efficiency means a great deal more than eliminating lost motion. A man may become so mechanical (in a good many instances due to specializing) that he is useless along other lines. The output of a shop depends greatly upon the system of handling, and almost any system is good that cuts out lost motion or duplication of work, following the different parts through the various departments, etc. However, the conditions in one shop might be so different from those in another that a system adopted in the one would not be effective in the other.

The output of a shop, of course, depends a great deal upon the organization. The operating conditions on our line during the past six or seven years have been very disastrous to our shop organizations. We have been compelled to reduce our forces almost every year, and in a great many cases have closed the shops entirely on account of depression in business; and every time this is done we affect the efficiency of the organization; some of the best mechanics in the country have left our shops on account of the fluctuation in working conditions. In opening up the shops again, we have been compelled to hire almost any one that comes along representing himself to be a mechanic. A great number of these men only work a sufficient length of time to get a "stake," and we have experienced a condition that is hard on any kind of an organization, as we have found it necessary at times to hire on an average of 25 men a day at our Danville shops in order to keep our force of men at a given number.

Taking it for granted that a man is a good mechanic, I will venture to say that he will not develop 100 per cent. efficiency to the company until he has been in the service a certain length of time, say one or two months, as there will be conditions with which he is not familiar, and it takes time to educate him. In addition, mechanical departments have experienced in the past a great many delays on account of shortage of material. This is not a reflection on the stores department, but due to the fact that retrenchments were necessary and they could not order material far enough in advance to prevent shortages when shops were again opened up.

It would be difficult for me to estimate the loss to any railroad company due to the fluctuation in working conditions, but I feel satisfied that if the conditions would permit working the shops

uniformly the year around, the railroads would effect a great saving, and at the same time have the power in good condition, or comparatively so, all the time; in this way the mechanical department could figure on a certain number of engines falling due for the shop each month, whereas, during the past several years, the greater proportion of heavy locomotives have been put through the shops during the months of August, September, October, November, and December, which, you will appreciate, makes them all fall due about the same time the following year, and this is a condition that works hardships on the mechanical and operating departments. To illustrate this point: A railroad receives a lot of new locomotives in the month of November, and under ordinary conditions these engines remain in service approximately fourteen months, necessitating shop attention about January, when, in all probability, there is the greatest demand for their service. The necessity of retrenchment curtailing the output of a shop in the summer months, prevents the repairs to other locomotives in the same class, making a shortage of power, and congestion, which would make it inadvisable to shop these engines when due. To relieve a situation of this kind, it is occasionally necessary to advance the regular date of shopping to prepare the heaviest power for the service in winter months, and this necessarily increases the maintenance cost, also necessitates engines continuing in service longer than their condition would warrant, probably decreasing the miles run per failure, and unless these conditions are fully considered it is hard to get a fair comparison.

#### DISCUSSION.

A. R. Kipp, mechanical superintendent of the Chicago division of the Soo Line, stated that the size of power and the grades over which the engines operate were features that must be considered when comparing shop output. For this reason the miles run, or the ton miles, would not be a fair basis on which to compare. He believed that by taking an average tractive effort unit, say 20,000 lbs., for example, and reducing other roads to that unit, more comparable information could be obtained. If one road had an average tractive effort of 30,000 lbs., its factor would be 1.5, while another having an average tractive effort of 40,000 lbs. would have a factor of 2, and by reducing the output from average tractive effort down to one, the comparison would probably be as near as could be made.

**QUICKER LONDON-PARIS SERVICE.**—As a result of the experience gained since its inauguration on July 1, it has been decided to continue the new week-day afternoon service from London to Paris. So easily has the scheduled run of 90 min. for the 77 miles from Charing Cross to Dover been maintained in working by the 4:30 p. m. train, even during the busy holiday season, that it has been found possible to alter the departure time of the boat from Dover from 6:15 to 6:05 p. m. The original time of the French train is meanwhile being retained until the end of this month. From December 1, instead of leaving Calais at 8 p. m. and reaching Paris at 11:25 p. m., it will leave Calais 7:45 p. m. and reach Paris 11 p. m. This will bring the time of the journey from London to Paris down to 6½ hours, making this considerably the quickest journey between the two capitals in either direction. The new acceleration is mainly due to saving time at the ports, but the French running time is quickened by 10 min., thus making it 1 min. faster than the 9:55 a. m. Paris-Calais train, which at present holds the record between these two points. In the reverse direction the 12:30 a. m. week-day service from Paris to Calais will also be continued (except on Christmas Day and Good Friday), but with its existing time for the present. From November 4 to May 15 passengers arriving from the Riviera at the Gare de Lyon at 10:16 p. m. can go thence direct by sleeping car to Calais without driving across Paris. Similarly, in connection with the 9 p. m. service from London a sleeping car now runs from Calais to Paris, arriving at 7:10 a. m.

## CLIFFORD THORNE AND E. P. RIPLEY ON POSSIBLE SAVINGS UNDER GOVERNMENT OWNERSHIP.

As indicated in an editorial published in the *Railway Age Gazette* for November 7 (page 853), Clifford Thorne, chairman of the Railroad Commission of Iowa, in a discussion at the recent convention of the National Association of Railroad Commissioners, sought to show that under government ownership of railways in this country a saving of \$464,000,000 could be made in the annual return paid to railway capital. The way in which Mr. Thorne reached this conclusion was shown in the editorial referred to. Mr. Thorne's statements drew a letter from E. P. Ripley, president of the Atchison, Topeka & Santa Fe, in which Mr. Ripley pointed out to him that by using misleading figures regarding the interest and dividends now paid annually by the railways Mr. Thorne had fallen into an error of \$211,000,000 a year. Continuing, Mr. Ripley said:

"You stated that the (net) capitalization of the railways on June 30, 1912, was \$15,286,101,947; and you calculated, on the basis of the market prices of railway securities in October, 1913, that the railways could be acquired by the government for \$13,969,173,383. Even assuming that the conclusion drawn by you from the current market prices was correct—and I do not believe this to be the case—you chose as the basis of your calculations the quotations in a month when railway securities reached one of the lowest levels to which they have fallen in years. It would be just as fair to make a similar calculation based on the quotations in some month when the prices of railway securities were at their maximum, which, of course, would yield a very different result. United States Senator Albert B. Cummins of your own state a few years ago estimated that a valuation of all the railways of the country would amount to \$20,000,000,000; and his figure probably is a much better index of what it would cost the government to acquire the railways than is yours. You estimate that if the government acquired the railways it would have to pay only 3 per cent. interest on the bonds issued by it. If you have studied the present prices of bonds of the United States government and of the securities issued by the governments of other countries you are aware that no government could today issue a large amount of 3 per cent. bonds at par, and that any government that could issue them at less than 4 per cent. would be fortunate. If the United States government should buy the railways at a cost of \$20,000,000,000 and should have to pay 3½ per cent. interest on the money its total interest would amount to \$700,000,000 a year, which exceeds the total interest and dividends now paid by the railways.

"In conclusion, I call your attention to the fact that you make no allowance for the great increase in railway operating expenses that almost certainly would result under government ownership, thereby more than wiping out any conceivable saving that could be made in the cost of capital. The last large railway acquired by the government of a democratic country is the Western Railway of France; and in the four years 1908 to 1912, inclusive, its gross receipts increased only 12 per cent., while its operating expenses increased over 50 per cent., in consequence of which its net earnings declined almost 70 per cent. I leave you to calculate what would be the consequence to the American people if government ownership should be adopted in this country, and government management should produce such results as it has produced in France."

Mr. Thorne answered Mr. Ripley's reply in a letter, in which he admitted the erroneous use of figures regarding interest and dividends, but sought by a different method of calculating to show that the saving which he had estimated could be made was not excessive. This drew from Mr. Ripley, under date of November 15, another letter, the text of which shows the basis on which Mr. Thorne made his second calculation regarding the possible savings, and also replies to Mr. Thorne's argument. Mr. Ripley's second letter to Mr. Thorne is as follows:

"I have your letter of November 11, replying to mine of

recent date in which I criticized your attempt to show that under government ownership of railways in this country over \$464,000,000 of the return now paid annually to railway capital could be saved. Before replying to some of the statements made in your letter permit me to make clear my own position regarding the question of government ownership in the United States.

"I do not oppose this policy as a railway officer. The government could not acquire the railways without paying just compensation for them. The roads are now being so regulated that the security owners are not receiving an adequate return, and if they could get their money out they could invest it where it would earn a larger return. Therefore, government ownership might be a blessing to the owners of railway securities. While I do not oppose government ownership as a railway officer, I do oppose it as a citizen, because I believe that under our form of government and political conditions it would be the greatest calamity that could possibly befall the American people. You say in your letter, 'Within the next five or ten years you will see government ownership will be one of the great political issues of the day in the United States, and when that issue arises in all its vast importance the real problem will be whether the operation of the railroads can be divorced from politics.' But, upon what conceivable ground can anyone assume that politics would be kept out of the management of state railways in the country? It is not now kept out of the management of the state railways of any country, with the possible exceptions of Prussia and Japan. Furthermore, politics is not now kept out of anything done by our own governments. Since we cannot keep politics out of our river and harbor improvements, or out of our appropriations for public buildings, or even out of our legislation regarding the location and maintenance of army posts and naval stations, how can it be rationally assumed that we could keep it out of a state railway system employing 1,700,000 citizens and voters? And if we did not keep politics out operating expenses would increase by the hundreds of millions annually.

"In my first letter I called your attention to the fact that by using misleading figures in your address to the National Association of Railway Commissioners at Washington in regard to the total annual interest and dividends paid by the railways of this country you had fallen into an error of over \$211,000,000. You now admit the justice of this criticism. Referring to the figures used by you and my criticism of them, you say, 'I believe your point is correct that such totals include duplications which should be deducted because of payments to railroads by other railroads resulting from mutual stock and bond ownerships.' Having conceded this, you attempt to show by a wholly different method of calculating that a saving equal to that originally estimated by you could be made, and 'challenge' me to show wherein you may be in error. I have read with mixed feelings of amusement and astonishment the figures given and conclusions drawn in this, your second utterance on the subject. I am unable to decide in my own mind whether the nonsense you write is due to the fact that you are ignorant and are yourself deceived, or to the fact that you are trying to mislead others. In either event it is inconceivable how a man who has succeeded in getting the public confidence to such an extent as to have become chairman of the railroad commission of a great state can be capable of using railway statistics as you did in your address to the National Association of Railway Commissioners and again in your letter to me. You enjoy the unique distinction of being the only railroad commissioner I ever heard of who did not know the difference between an *addition to railway income* and a *deduction from it*. In your address at Washington you gave the total interest and dividends paid by the railways in 1912 as \$883,000,000, and in my letter to you I called your attention to the fact that the total net operating revenue of the railways in that year was less than \$868,000,000, and that, after paying taxes, they had left only \$755,869,486 net operating income. In your reply you say, 'You exclude \$255,611,495, representing "other income," as well as \$123,898,207 income from non-operating roads.

A substantial portion, but not all, of these figures should be legitimately included.' Now, of the \$124,000,000 which you assume was paid by the non-operating roads to the operating roads, and therefore should be added to net operating income, no less than \$117,400,000 was paid by the operating roads to the non-operating roads, and was, therefore, a deduction from the increase of the operating roads! As to the \$255,600,000 'other income,' you apparently assume that this was derived from outside investments, and was, therefore, additional to the revenue derived by the railways from their own operations. Here again, you are completely in error. This 'other income' is made up almost entirely of payments of an intercorporate operating or financial character made by the railways to each other. For example, it consists chiefly of the very duplication of interest and dividend payments which you yourself now admit should be eliminated in treating the railways as a single system. The complete figures of the Interstate Commerce Commission for 1912 are not yet out, but those for 1911 are, and by turning to the commission's income account of all the railways considered as a single system, on page 53 of its Statistics for 1911, you can ascertain by a simple calculation that the total amount of money which the railways had available in that year for interest, dividends, improvements, etc., after making all proper allowances for and deductions from both their operating income and their 'other income,' was \$785,297,599, which is about \$350,000,000 per annum less than the sum arrived at by adding together the net operating income, the 'other income' and the income of non-operating roads, as you, by implication, suggest should be done to ascertain the total net income of the railways. The mistake made by you in your Washington address as to the total interest and dividends paid by the railways was only \$211,000,000. The mistake now made by you regarding their total income amounts to \$350,000,000. I grow curious to know how much your mistakes would ultimately increase to if this correspondence should be long continued?

"Having conceded that the estimate originally made by you as to the annual saving that could be made in return to railway capital under government ownership (namely, \$464,000,000) must be reduced by at least \$211,000,000, you add that even after this deduction the saving which could be made on the basis of your calculations as to what the government would have to pay for the railways and the rate of interest which it would have to pay on the bonds which it would issue for this purpose would be \$250,000,000 annually. But, as I clearly indicated in my first letter to you, both your estimate as to what the government probably would have to pay to the railways and your estimate as to the rate of interest which it would have to pay on the debt incurred by it, are too low. Since your premises regarding these matters are baseless, it follows that the conclusions which you persist in drawing from them are absurd.

"Continuing, you call attention to the fact that after paying operating expenses, taxes, interest, dividends, etc., in 1911, the railways had left \$161,800,000, which they used for additions and betterments, for the construction of new lines or extensions, carried to their general balance sheet, etc. You add that this 'would go to the public under government ownership.' But if under government ownership the government should take this money and use it for purposes other than those to which it is now devoted, it would not make the improvements, extensions and so on which are now made from it. In that case, either these improvements, etc., would not be made at all, or they would be made from the sale of additional securities. In the former case needed improvements would be wanting. In the latter case capitalization would be increased faster than now, more money would have to be earned to pay a return on it, and in the long run the public would be worse off than it is under the policy now followed by the railways. The railways of the United States have followed the policy of making substantial expenditures from earnings for improvements from year to year, very little of which has been capitalized, and most of which

has gone for improvements of great benefit to the public, but which earns nothing for the railroads—such as fine passenger stations, track elevation, elimination of grade crossings, etc., and on June 30, 1911, according to the statistics of the Interstate Commerce Commission, they had outstanding a capitalization of only \$63,944 per mile, on which to earn a return. The British roads have followed the policy of making all additions and improvements from new capital, and on the same date they had a capitalization of over \$275,000 per mile on which to earn a return. The American policy is obviously the less costly in the long run, and, therefore, the saving of \$162,000,000 in expenditures for improvements, etc., which you estimate could be made, like the saving in the cost of capital which you estimate could be made, turns out to be purely imaginary.

"You attempt to strengthen your argument for government ownership by saying, 'Remember, the large majority of the civilized countries on the globe—three-fourths of them—already own most of their railroads.' You seem to know as little about the railways of the world as about those of your own country. The latest complete compilation of the railway mileage of the world was made by the *Archiv für Eisenbahnwesen*, the official publication of the Prussian state railways, as of January 1, 1910; and the figures given by it in its issue for May and June, 1912, showed that the total length of the railways of the world was 639,621 miles, and that of this governments owned only 186,068 miles, or 29 per cent., and private companies, 453,554, or 71 per cent. Even excluding the large privately-owned mileage in the United States, the mileage owned by private companies in the rest of the world was 212,497, or 26,429 miles more than the total government-owned mileage. Europe and North America are hardly the least civilized parts of the world; and on these two continents the mileage owned by governments was only 120,040 miles, while that owned by private companies was 380,531 miles, or over three times as great. It is true that most of the mileage of Germany is owned by the states, but all of that of England is owned by private companies. Most of the mileage of Austria-Hungary is owned by the state, but 82 per cent. of that of France is owned by private companies. While most of the mileage of Italy, Switzerland, Norway and Australia is owned by the government, most of the mileage of Sweden, Portugal, Canada and Argentina, is owned by private companies. Contrary to your apparent belief, and probably to the belief of most persons, private ownership is still decidedly the preponderant policy of the world."

RAILROAD CONSTRUCTION IN THE PHILIPPINES.—So far has the construction work on the Baguio branch of the Manila railroad progressed that the passenger equipment has been ordered and is expected to arrive in Manila during the latter part of 1914. On the 24 miles of the branch grading has been completed on 7 miles of the Aringay end and on an equal stretch of the Baguio end. Sixty per cent. of all the grading material along the road has already been moved, and on June 30, four miles of track had been laid. The construction of bridges along the railroad has not progressed very far, but from now on bridges will be put in in rapid succession. Three of the 123 bridges have already been completed. The special rack-track material which will be used for 8 miles of the road where a rack-track system will be installed has been ordered, and delivery is expected to begin soon. One second-hand rack locomotive has been delivered and will be used for construction purposes. Six rack locomotives will be used in the regular service. Three of these locomotives are expected to arrive here by March, 1914, and the remainder by November, 1914. Of the three tunnels under construction, the one located nearest Aringay is nearly completed. Satisfactory progress has been made on the other two. Between 2,000 and 4,000 men are constantly being employed on the construction work. At the present time the construction force numbers 3,500.



## SMOKE WASHING PLANT AT ENGLEWOOD.

The Lake Shore & Michigan Southern has installed a smoke washing system in the new 30-stall engine house at Englewood, Chicago. The illustration shows it in full operation handling the smoke from 22 engines, about ten of which had green fires. The smoke from the engines discharges into Dickinson cast iron telescopic smoke jacks which fit over the stacks. A damper is provided in each jack which provides a means for regulating the draft on the engine while it is in the engine house, and also allows the draft to be shut entirely off when it is not desired to use the jack. The draft is obtained by a special 78-in. Type S steel plate fan, made by the American Blower Company, and is driven by a 100 h. p. alternating current motor.

The smoke duct is supported on the roof timbers of the engine house. It is of circular section and is made of Transit asbestos board. This discharges into a 48-in. pipe that leads to the fan. The smoke duct on the discharge side of the fan delivers the smoke to three smaller ducts that lead to separate compartments in the washing tank. As the tank ends of these ducts deliver below the water level, the water backs up some 10 or 15 ft. in the ducts. A steam jet is placed in each duct



Smoke Washing Plant of the Lake Shore at Englewood.

to agitate the water so that the smoke and the water will be thoroughly mixed. This mixture passes into the tank compartments and the free gases are caught in chambers from which they are forced back into the water as the pressure builds up and are finally liberated, after the solid matter has been completely taken out by the water, to a wooden stack 65 ft. high.

The residue left from this washing process is made up of the following constituents:

Carbon .....	82.6	per cent.
Sulphur .....	2.6	per cent.
Moisture .....	3.9	per cent.
Iron Oxide .....	8.7	per cent.
Silica .....	1.8	per cent.
Calcium and Magnesium Oxides.....	0.4	per cent.

This residue will float on the water and is removed each

day, about 10 barrels per day being obtained when the plant works at its average capacity. While no analysis has been made of the water, it is supposed to contain a large amount of sulphurous acid which actively attacks any iron or steel work. For this reason it has been found necessary to build all parts coming in contact with the water of wood which is painted with a tar paint. About 95 engines a day are handled at Englewood. It has been found unnecessary to use a blower for the engines except when it is desired to rush an engine with a green fire. The leakages at empty jacks have not been found to be of any disadvantage.

This is the first successful plant of this kind that has been built. In the early part of 1910 a smoke washing plant was installed at the Chicago avenue engine house of the Chicago & North Western at Chicago, in which the spray system was used. While this was more or less successful while it lasted, the corroding effects of the gases and water put the plant out of commission in a short time, steel and iron having been used throughout its construction. On account of the lack of available space this plant has not been reconstructed. It was found impractical to use the spraying water more than once as it would soon eat away the pump parts, and a continual supply of fresh water was necessary. With the experience gained from this plant and from a model plant experimented with at Collinwood, Ohio, the Lake Shore mechanical officials designed and built the present plant at Englewood which bids fair to be a success. Throughout the work on both roads consistent support and interest has been displayed by the city smoke inspector's office of Chicago. The details of construction will be published in a later issue.

**INCREASED TRAFFIC FACILITIES IN GERMANY.**—Because of the need of additional siding and main track accommodation in the industrial districts considerable engineering work is now in progress in the neighborhood of Düsseldorf, Ruhrort and Duisburg in the shape of the conversion of loops into running tracks, widenings, and the provision of additional sidings. Much is also being done in the way of providing humps to facilitate switching. Few people are aware of the amount of traffic dealt with in the yards on the Ruhr. At Duisburg alone, 1,000 trains are dealt with daily.

**GAGE OF SOUTH AUSTRALIAN RAILWAYS.**—South Australia is distinguished from the other Australian states in that it possesses a considerable amount of mileage of two gages, 5 ft. 3 in. and 3 ft. 6 in. Making an early start with its railways, it adopted the same gage (5 ft. 3 in.) as the neighboring state of Victoria for most of its main lines. Later on it adopted the 3 ft. 6 in. gage in the extension of its main lines northwards and for all the secondary lines, so that now the greater mileage in the state is on the narrower gage. The leading features of South Australia are the vast plains of arable land, largely free from timber, on which are grown great quantities of wheat. There is also a large growth of fruit of all descriptions, and vineyards which produce some of the best wines in Australia. Mineral traffic supplies a traffic of nearly 1,500,000 tons.

**CAR SHORTAGE IN GERMANY.**—Judging from the statistics just issued for the month of September the lesson learned last year from the unprecedented car shortage, especially on the Prussian State Railways, has not been lost. One of the complaints of the Prussian State Railway authorities was the dilatoriness in returning cars. There were probably other reasons such as a want of foresight as to the requirements of the important industrial districts in spite of the timely notice they had received as to probable demands. The increase in the number of cars other than box cars supplied, as compared to last year, amounted to 250,166 or 8.4 per cent. in favor of this year. There was a shortage of 43,638 box cars as compared to 117,020 last year and a shortage of only 8,487 other cars as against 96,583 for the same month in 1912. Whether this record will be upheld in the months of heavy traffic still to follow remains to be seen.

## MODERN APPRENTICESHIP.

By JOHN H. LINN.

Few people realize how great has been the growth of industrial education during the past few years, and especially the development of apprenticeship methods. We have heard more or less of the apprenticeship systems of the New York Central and of the Santa Fe, and of their remarkable success, but many of us have not kept pace with the rapid development of this movement on other roads and with other corporations. The report of the committee on apprenticeship at the last meeting of the International General Foremen's Association showed that of 25 railroad companies and 20 other corporations to whom inquiries were sent, each was offering its apprentices certain educational advantages; 16 out of eighteen railroads and 17 out of 20 other corporations were paying their apprentices for the time spent in school.

The spread of this movement is further evidenced by the organization of the National Association of Corporation Schools. At the first annual convention recently held at Dayton, Ohio, there were representatives present from some 150 corporations. The following partial list will serve to show the character of the companies represented: The New York Central, Atchison, Topeka & Santa Fe, Pennsylvania, and Baltimore & Ohio railroads; the American Locomotive Company, Westinghouse Electric & Manufacturing Company, New York Edison Company, General Electric Company, Western Electric Company, Yale & Towne Manufacturing Company, Cincinnati Milling Machine Company, International Harvester Company, Curtis Publishing Company, National Cash Register Company, Burroughs Adding Machine Company, Packard Motor Car Company, and Cadillac Motor Car Company. The purpose of this association is to render new corporation schools successful from the start by warning them against the pitfalls into which others have fallen and to provide a forum where corporation school officers may interchange experience and so improve the instruction in their institutions. The first convention was a very enthusiastic one, many phases of industrial education being discussed. The purpose of this article is to touch on only that part of the convention which concerns the training of mechanical apprentices, the following being a brief report of the more important ideas brought out in the papers and discussions of this subject:

### THE SCARCITY OF MECHANICS.

Every speaker mentioned the scarcity of skilled mechanics. It is the business of the railroads to sell transportation. They cannot satisfy their customers unless they maintain their equipment in first class condition. They cannot do this without skilled men, and since they cannot hire these either in the number or of the quality desired it is necessary to develop them according to their needs. The same is true of the manufacturing concerns. There was some difference of opinion as to the best method of training these men but all were agreed that each company should make the best effort possible to train its own employees, the exact method depending upon each shop and the particular needs of each company; in general the training should consist of a certain amount of theoretical or school instruction, in conjunction with actual training in the shop.

### SELECTION OF APPRENTICES.

It was stated that if results are to be secured the very best boys possible should be employed as apprentices. There was difference of opinion as to the amount of schooling which these applicants should have received. A few companies restricted their applicants to full high school graduates, others to boys with two years of high school education, and a few to boys of sixth grade education. It seemed to be the experience of some of the companies that the high school graduates were in general not satisfied to stick out an apprenticeship course, but in many cases preferred a job in a dry goods store where they could wear clean clothes and have a better social standing. Some stated that the boys

with about two years of high school work had proved the most satisfactory, but the great majority took the position that taken all in all, boys with an eighth grade education had proved most satisfactory. Not all the companies require a physical examination, but those who do, strongly advocated this as being very important, the thought being that if we are to build up a body of skilled mechanics to supply the company's needs for a generation, we must take able bodied boys who will be worth something to us after they are graduated.

Many of the corporations in the east, particularly those in New York City, complained of the inability of getting good boys, stating that it was as hard to get good apprentices as it was to get good mechanics. One method which had been employed to get these boys was to hire them at the age of 14 and give them such work as they could find for them to do until they were 16 years of age or strong enough physically to enter upon the definite work of their trade. The idea in hiring the boys at this age was not only to get the boy himself in time but also to avoid the two years or so of idleness or perhaps worse than idleness, intervening from the time he leaves the discipline of the public school until he comes under the discipline of the shop. One representative stated that his company hired boys at 14 years of age and insisted on their having a common school or eighth grade education. This necessarily would give him only the brightest of boys and only boys from good homes as only boys of this class would be likely to complete the common school course by the time they were 14 years old. Sixteen seemed to be the popular minimum age for employing apprentices, boys younger than this being considered insufficiently developed physically and boys at 21 or over having been found less likely to adapt themselves to the training given them. The large waiting list of applicants with some companies was attributed by them to the attractiveness of their course, the real secret of getting apprentices and of holding them being in the treatment given them, each boy being a living advertisement. If the apprenticeship course is such that the boy gets a thorough training in the trade he is learning, there will be no dearth of applicants.

### WAGES OF APPRENTICES.

There was no agreement as to the wages which should be paid apprentices, except that they should be such as would correspond to the average wages paid boys of the same age in the same community. The wages should be such as to enable the boys to pay absolute living expenses from the start but not large enough to pay for luxuries.

### PROBATIONARY PERIOD.

The majority of delegates advocated a probationary period varying from two to six months; I think the majority favored the six months period. With many companies this probationary period did not count upon the apprenticeship but in the majority of cases, if the applicant were passed after his probationary period, this time counted on his apprenticeship time. The question of a boy's fitness for continuing the trade should not be left to one man but should be decided by a committee composed of the general foreman, shop foreman, school instructor, and shop instructor, and during his probation the apprentice should be given sufficient variety of work to bring out his fitness or ability.

### SCHOOL INSTRUCTION.

In starting an apprenticeship system the school instruction is given the first attention. All were agreed that the apprentices should be taught mechanical drawing, shop arithmetic, and such other subjects as are related directly to their trades. Many advocated going even farther than this and teaching some subjects relating to culture, etc., stating that we are in danger of going too far from our public school system, that the boys should be taught sufficient hygiene to make them take good care of their bodies, that a certain amount of the right kind of political economy would make them more loyal workmen and that a study of history or at least of the right biographies would make them

better citizens and consequently, better workmen. Great care should be taken that the boy is not taught anything that will make him dissatisfied with his trade. He should be taught that the work of a tradesman is as honorable as that of a banker and much more remunerative than most callings open to young men. The school instructor should be in constant touch with the shop instructor and as far as possible should make the instruction correspond to the work given the boy in the shop.

#### SHOP INSTRUCTION.

Many of the corporations when first starting an apprenticeship school system overlooked the important feature of shop instruction, but this is now receiving much more attention. The majority of the companies represented now offer shop instruction, feeling that the modern foreman has too many other duties to perform and is too vitally concerned in the immediate output to give the apprentices the instruction and training which they need. The question of the number of shop instructors was discussed, the recommendation being that there should be one for about every 25 boys. Many who had tried it said that the shop instructor would pay even if there were only half a dozen boys. The shop instructor should be a skilled mechanic, thoroughly posted on all the work of his trade and in addition, should be able to teach what he knows and to lead the boys in their shop work as well as to keep in touch with their activities both in the shop and outside of working hours. The school instructor, if possible, should also be a mechanic, but it was stated that it was very difficult to get school instructors who had sufficient theoretical education in addition to the shop work and that in many cases it had been necessary to hire a man who was not quite so well posted in shop work in order to get one sufficiently well posted along theoretical lines. The school instructor also should be able to teach what he knows and be a good mixer with the boys and yet one who can maintain his dignity.

#### SUPERVISOR.

The qualifications of the supervisor were also discussed. Some insisted that he should be a mechanic but others held that while this would be an added qualification it was not so essential as some others. The actual teaching of the trade must of course be done by a practical man, but the duties of the supervisor do not consist of such work; his position calls for ability to organize his department, to select his instructors and properly direct them in their work. He should be able to outline the course of instruction and above all should be one to inspire the best work of his instructors and to be loved and respected by all of the apprentice boys. Upon his head, whether he be a mechanic or a pedagogue, rests to a great extent the success of the enterprise and he must be an educator and leader in the true sense of the word.

#### SALARY.

There was a difference of opinion as to the salaries that should be paid. For the shop instructor some suggested from 45 to 60 cents an hour, others \$125 a month. The general trend of the discussion was that this should depend on local conditions and in general the salary should be about the same as that paid an assistant foreman. It seemed to be the unanimous opinion that to get a good school instructor, one sufficiently educated to handle the school work and also with a shop education, it would be necessary to pay him a larger amount than that paid the shop instructor; that unless this was done an inferior grade of school instruction would be obtained. The salaries suggested ranged from \$1,500 to \$2,000 a year, some saying that even this larger amount would be insufficient. The salaries suggested for the supervisor ranged from \$2,500 to \$5,000. It seemed to be the sentiment of all that men able to do this work could command this salary in public school work or in other lines of commercial work and that if we were to get the best we must pay these men as much as they can command elsewhere.

#### APPRENTICE TRAINING SHOP.

In connection with the shop instruction of the apprentices some companies have a training shop to which they confine the boys for the first part of their apprenticeship, no one working in the shop except the apprentices and their instructors. The representatives of these companies reported the plan as very successful but they were strongly opposed by others who thought it better for the apprentice to serve his entire time in the regular shop, working side by side with the journeymen and under conditions in which he will have to work after completing his apprenticeship.

#### COLLEGE GRADUATES.

In discussing the employment of college men, it was stated by some that their work was such that the college graduate was a necessity, that while the so-called self-made man could by observation, practice, private study and correspondence courses master much of the work, higher mathematics was his stumbling block and that it was practically impossible to learn this alone or by correspondence. In the railroad shop it was found that the college man was often surpassed by regular apprentices. It was urged that special apprentices should be given more practical work than formerly, and that so far as possible their training should be confined to the shop itself with a minimum amount of special work. There seemed to be no complaint of the college man's being unwilling to work or get his hands dirty and but very little of his overestimating his ability.

#### HOLDING APPRENTICE GRADUATES.

Many companies complained that their older boys left them, some automobile companies claiming that after they had had a boy two years he could go out and get a journeyman's wages as a machinist. Many of the companies are offering a cash bonus to the young men on graduation, and all urged that they should be so treated while apprentices and be given such a thorough training that they will be glad to continue throughout the entire course and to remain with the company after graduation; but if we are to hold them after graduation we must pay them a rate commensurate with their ability and promote the deserving ones to official positions as vacancies occur. If, however, these boys should leave the company they have paid as producers during their apprenticeship. Those who leave are staunch supporters of the shop in which they served their time, always ready to say a good word for it and as loyal as college graduates to their Alma Mater.

#### WELFARE WORK.

It was the general opinion throughout the convention that there was great necessity for the corporations paying more attention to the welfare of their men. The last century has been famous for improvement along mechanical lines of every description but the tendency now seems to be to pay more attention to the man himself. If it is important to get good machines it is also necessary to get the very best possible men to handle these machines and it is just as important to properly care for these men as it is to properly care for the machines. It is worth dollars and cents to the company to see that its employees are healthy and happy.

**INNOVATIONS ON ARGENTINE PASSENGER CARS.**—The Central Cordoba is placing in service several new restaurant cars. An innovation is the introduction of pianolas in the cars so that the passengers may enjoy music while dining. Some of the private cars are also to be fitted with the same class of musical instrument.

**TRANS-AUSTRALIAN RAILWAY.**—Work on the Trans-Australian Railway, such as fills, cuts, grading, etc., is progressing favorably. There is also general activity in the assembling of road-bed and other material along the route. Further contracts for materials, tools, etc., amounting to over \$2,500,000 have recently been placed. The interesting feature of the orders is that local engineering firms benefit to the extent of about \$850,000.

# THE FREIGHT RATE ADVANCE HEARINGS.

The Presentation of the Case by the Railroads—Statements  
by Mr. Willard and Mr. Delano—A Digest of the Evidence.

The hearing before the Interstate Commerce Commission in regard to the 5 per cent. increase in rates by roads in Official Classification territory was begun on Monday of this week. The presentation of the case was preceded by a high tribute to Mr. Marble both by Chairman Clark and Mr. Willard.

STATEMENT BY DANIEL WILLARD.

The railroads, parties to this proceeding, include practically all the lines operating in so-called Official Classification territory, which is substantially all that part of the United States east of the Mississippi and north of the Ohio and Potomac rivers. The same companies were also parties in a similar proceeding before this commission in 1910.

In its report of that investigation, known as I. C. C. 3400, the commission made a comprehensive review of the whole subject and found that the carriers had failed to establish the need of additional revenue from increased rates at that time. It recognized, however, that it might come about in the future, as the carriers feared, that the net earnings from the then existing basis of rates would be inadequate, but held that this could only be determined by an actual test. It said: "If actual results should demonstrate that our forecast of the future is wrong, there might be ground for asking a further consideration of the subject."

Since 1910 sufficient time has elapsed to afford the actual test, and with the records of operation for the three intervening years available, the same carriers appear again, believing that the results of the actual test will now demonstrate the necessity for additional revenues or net earnings.

In I. C. C. 3400, page 19, the following language is used:

Our railroads must be maintained in a high state of efficiency. This the public interest demands. Commerce and industry cannot afford to wait on transportation facilities. Our rates should be such as to render possible a high-class, not an extravagant service.

It is generally conceded that within the next few years, if our means for transportation by rail are to keep pace with the calls upon them, very large sums must be expended in the way of new construction and new equipment. While some small portion of this may come from current earnings, the great bulk must be new capital. This capital must be obtained from the investing public.

If, therefore, we are to rely in the future, as we have in the past, upon private enterprise and private capital for our railway transportation, the return must be such as will induce the investment. It is therefore not only a matter of justice, but in the truest public interest that an adequate return should be allowed upon railway capital.

While the carriers fully recognize and acknowledge their obligations to the public, and are alive to the responsibilities so imposed, they are helpless to fulfill these obligations, unless the financial result of their operation is such as to inspire the confidence of private capital and encourage the support of private enterprise, and the result of operation during the last three years is not such as to inspire the one or encourage the other.

This as we view it is the situation to-day, and if we are right it is respectfully submitted that there is at this time no more important question before the people, nor one the correct solution of which will do more to stimulate healthy commercial activity, and promote industrial growth. It is a mistake to think that the problem is merely a question of dividends to railroad stockholders, although that feature is of course involved. The problem in a broad and true sense affects all interests, and the outcome of this particular case—whichever way it is decided—will mark an epoch, because it will, in effect, very largely determine whether we shall as in the past continue to look to private capital and private enterprise for our transportation requirements, or be compelled finally to accept the only alternative possible. It is recognized, of course, that railroad expansion and improvements must go on, and any tendency or condition that

threatens to seriously check, if not completely stop, such expansion in a large and important part of the United States becomes, because of that fact, a matter of vital importance.

This commission in its report, I. C. C. 3400, said that the railroads had failed to establish a necessity for higher rates at that time. It also said, in effect, that it believed that from the increase in gross earnings which would undoubtedly come to the railroads, together with such economies as the companies might effect, the net earnings of the future would be adequate, but it also said that should it come about that its views were not sustained by future developments, and should it appear at any time that there was a real necessity on the part of the carriers for increased revenue, in order that they might be in position to provide such facilities as the public required, it would, upon request, give the matter further consideration.

During the first two years immediately following the decision, the commerce of the country showed little, if any, change in volume, but during the last fiscal year there was a marked activity in business of all kinds, and the gross earnings of the railroads generally for the year ended June 30, 1913, were the largest in their history. Notwithstanding the increased gross, however, the railroads in Official Classification territory continue to show decreases in net earnings, and as the commission well said in the opinion above referred to, "It is the net, not the gross, we must consider." This decrease in net earnings has been due largely to greatly increased expenses, as pointed out in the petition which the carriers filed for rehearing on May 14, 1913, from which I will quote:

The cost of conducting the business of the carriers has been, and is being, steadily increased by increases in capital charges; increases in wages, in taxes, by burdens imposed by legislative enactments, such as extra crew laws, employers' liability and compensation acts, by the elimination of grade crossings, either in part or in whole at the expense of the carriers, and in various other respects, and it is felt that existing rates are insufficient to afford just and reasonable compensation and return to the carriers, and are unreasonably low in view of the value of the service afforded thereunder.

In the application for rehearing, just referred to, the carriers asked permission to advance freight rates in Official Classification territory on the basis of 5 per cent., with reasonable minima and with the modifications necessary to preserve differential relations. The commission thereupon ordered that this proceeding of inquiry be instituted into the following matters:

First, do the present rates of transportation yield adequate revenues to common carriers by railroads operating in Official Classification territory?

Second, if not, what general course may carriers pursue to meet the situation?

The railroads, parties to this proceeding, have prepared new tariffs, advancing freight rates as suggested in their petition, and have placed the tariffs on file with this commission, and at stations so that all concerned might be fully advised regarding the effect of the proposed increase.

In order to develop the whole situation and to show the actual operating results obtained during the last three years, tables have been prepared, containing such information as is necessary to show the changes that have gradually come about in property investment, earnings, cost of operation, income, etc., not only during the three-year period, but also for the last ten years. This has been done because the influences which have brought about the existing conditions have been operating over a considerable period of time. The present situation, and the gradual but consistent tendency in that direction are both clearly indicated in these tables. Separate tables have been prepared for each of the several companies for the periods above mentioned, and a combined statement giving the consolidated figures for all of the

companies has also been prepared, and all of the tables have been or will be filed with the commission.

A brief reference to some of the more striking features in the statements may be pertinent at this time. The consolidated statement shows, for instance, that during the fiscal years ended June 30, 1911, 1912 and 1913, the railroads interested in this movement increased their property investment \$659,862,000. The gross earnings of these roads during the last fiscal year were \$1,424,119,000, or \$186,775,000 greater than they were in the fiscal year ended June 30, 1910.

The operating expenses and taxes during the last fiscal year, for the same roads at \$1,087,365,000, were \$203,087,000 greater than they were in 1910; so that even though these railroads earned in gross during the last fiscal year \$186,775,000 more than was earned three years previous, the net result, after paying operating expenses and taxes, was actually \$16,311,000 less than it was in 1910, notwithstanding the fact that over \$659,000,000 of additional money had been spent in the meantime for additions, betterments, and equipment. These companies apparently not only failed to earn any return whatever upon the new capital invested, but saved even less from gross earnings, as return upon the original property investment, than they were able to show before this large additional expenditure was made.

Another table has been prepared showing the combined results for the same period, of the Pennsylvania, New York Central and Baltimore & Ohio systems, these particular companies having been referred to by the commission in report I. C. C. 3400 as typical systems. This table shows that on these three systems during the three-year period mentioned, the property investment was increased \$423,431,000. The combined gross earnings during the same period increased \$109,380,000, while net operating income of all three systems, after paying operating expenses and taxes, was \$8,380,000 less in 1913 than in 1910, notwithstanding the fact that over \$423,000,000 had been spent in the meantime for betterments, additional equipment, etc. I might also add that in the single case of the Baltimore & Ohio system, the tables show that the property investment of that company was increased over \$56,000,000 during the same three-year period; the gross earnings in the meantime increased over \$13,000,000, but the net operating income in 1913, after paying expenses and taxes, was \$660,000 less than in 1910.

The separate reports of the roads or systems which will be submitted show that the same tendencies have operated in greater or less degree in the case of each individual company. In brief, it appears to have come about that the new capital invested in railroads in Official Classification territory during the last three years has earned little or no return; in fact, these properties generally are actually earning less net, after paying operating expenses and taxes, than they were earning at the beginning of the period, and before the \$659,862,000 had been spent. It would seem that the mere statement of the case should be sufficient to indicate the serious situation which confronts not only the railroads in this territory, but also those industries and commercial undertakings which depend upon the railroads for transportation.

The result, as might be expected, of this constant tendency toward diminishing net returns, has been to seriously check, if not altogether stop, the normal development of railroad facilities in the territory affected. The tables show that during the ten-year period these railroads found it necessary to increase their property investment approximately \$2,000,000,000, an average of about \$200,000,000 per annum, and it is certain that an equal if not greater amount per annum will be necessary to meet the requirements of the future.

Railroad managers would hardly be expected, under the circumstances just stated, to continue large capital expenditures for betterments and additions, if possible to avoid doing so, at least unless they had reason to believe that something had happened or was about to happen, which would materially change the situation. It is believed that the preceding statements, if confirmed, are sufficient in themselves to justify the request which the car-

riers now make for advanced rates, unless it can be shown that the causes which have operated to bring about such results are of a temporary character, or have now ceased to exist. As already stated, while the matter has only recently reached an acute stage, the influences which have as a whole served to bring about the present condition have been operating for a number of years. Evidence will be submitted to show some of the contributing causes and their effects. It was shown in case I. C. C. 3400 that the advanced wage movement culminating in 1910 would increase the wage payments of the railroads in this territory approximately \$34,000,000 per annum. The commission, in its report, expressed the opinion that in view of the large recent increases, it seemed fair to assume that wages would not much increase in the immediate future. Evidence to be submitted, however, will show that subsequent to the general increase in 1910, a similar movement was inaugurated in 1912, and increases already gained by this last movement—largely as a result of mediation and arbitration proceedings—have greatly augmented the wage payments of these same carriers.

The award just recently announced by the arbitrators in the matter of the application for increase in wages by the conductors and trainmen in Eastern territory, it is estimated, will give approximately \$6,000,000 increased wages annually to the conductors and trainmen employed by the railroads affected, all of which are in Official Classification territory. The effect of this increase is not shown in any of the other figures which I am using at the present time.

A full statement, showing the general wage increases made during the three-year period, and the procedure under which they were obtained, will be presented.

The total wage payment of the Baltimore & Ohio system has been increased by an amount in excess of \$4,000,000 per annum, comparing the fiscal year 1913 with the fiscal year 1910, due to increased rates of pay and changes in working conditions. Approximately one-half of this amount, or \$2,000,000, is due to advances gained by the movement begun in 1912, and subsequent to the increases considered by the commission in the 1910 investigation. This indicates in a general way what has also taken place with each of the other companies. It should be borne in mind that the wages paid on the several roads interested in this proceeding are very nearly on the same basis, and with substantially the same working conditions.

Since 1910 there has been an increase in the cost of materials, due in part to increased use and higher standards, and in part to increased prices of certain materials entering largely into the cost of operation, such as fuel and track ties. The advance in price of these two items alone in the case of the Baltimore & Ohio system served to increase the expenses of that company in 1913 more than half a million dollars above what they would have been had prices remained as in 1910.

The amount paid for taxes by the companies, parties to this proceeding, has shown constant increases during the whole ten-year period, and particularly during the last three years. The increase payment in 1913 over 1903 was \$28,720,000, and the increase incident to the last three years was \$11,579,000. In the case of the three systems selected by the commission as typical, the amount of money actually paid as taxes during the year 1913 was \$31,216,000, being \$7,854,000 more than was paid in 1910.

Legislation, both state and federal, enacted during the last ten years, has brought steadily increasing burdens upon the carriers. It is not proposed to question the merits of any of the legislation referred to in this connection. For the present purpose, it is sufficient to say that the effect upon cost of operation has been and will be the same, regardless of the merit of the measure. Among the measures which have affected cost of operation I may mention: Employers' liability and compensation acts, full crew bills, so-called semi-monthly pay laws, safety appliance and standardization of equipment acts, and acts requiring the elimination of grade crossings, etc. The effect of the so-called full-crew laws alone has been to increase the expenses of these carriers more than \$4,000,000 per annum.

The public demands to-day a higher standard of service than ever before, and while it may be that the wishes of the public in this particular have not been fully realized, none the less much has been done in that direction, all of which is reflected in the cost of operation.

One other very important influence upon the expense of railroad operations, when considered in a broad sense, is the higher rate of interest which the companies have been obliged to pay in recent years for new money raised for improvement purposes. It is believed that in the case of the carriers particularly the cost of new capital has been made higher than it otherwise would have been by the constantly narrowing margin between income and outgo, as it is upon this margin chiefly that the railroads in this territory must rely as the basis for raising additional capital.

In short, the railroads have felt the burden of the increased cost of living, like all other enterprises or individuals, but unlike all others have not been permitted so far to raise their prices or adjust their charges in recognition of that burden.

Further, the rates which were in effect in 1910 have not in the aggregate been maintained—that is to say, while certain increases have been made during the period in mind, decreases have also come about, so that the general basis of rates has been lowered, to some extent by orders of the regulating commissions and perhaps to an equal if not greater extent by commercial conditions or influences beyond the power of the carriers to resist. The net result of this movement is indicated in the statement that if the same rates and classifications which were in effect in 1910 had remained in effect in 1913, the freight earnings of the Baltimore & Ohio system, in the year last mentioned, would have been over \$900,000 greater than they actually were, and the net income would have shown the same increase. It should be understood that this tendency will continue to lower the general level of the rate structure for some time to come, and it should be taken into account when deciding upon any fair basis of rates for the future.

In addition to the actual reduction in rates, above referred to, the continuous decline in the value, that is to say the purchasing power of money for a number of years past, has had the effect of diminishing still further the burden of the rate to the shipper, while at the same time increasing the burden of the carriers. This influence, reflected in the higher cost of operations, has been world-wide, and has been recognized by rate advances recently made by railroads in England, Italy, Switzerland, Belgium, Denmark, Russia, Austria, Hungary, and other countries.

Having set forth the results of the operation of these carriers, to show that the revenue received upon the existing basis of rates is inadequate, and having pointed out some of the causes which have served to bring about this condition, we come now to a consideration of what general course the carriers may pursue to meet the situation.

If the situation is as I have shown, it is clear that the remedy must come from such changes, or such line of action as will serve to increase net earnings, and this result might be brought about by one of three methods or by a combination of some or all of them. A large reduction in cost of operation—other conditions remaining as at present—would produce larger net earnings. A large increase in gross earnings, if the additional business could be handled with the present facilities and at present operating ratios, would also result in a larger net, and it is obvious that an increase in freight charges, other conditions remaining as at present, would bring about the same result.

I do not believe it will be possible to obtain the necessary relief either by reducing wages already in effect, or by making any very considerable reduction in the number of men employed; nor do I believe it will be possible to effect economies in operation of sufficient magnitude to have any saving effect upon the situation. Undoubtedly further economies will be brought about, but it is altogether likely that in the future, as in the past, they will be more than offset by increased taxes, by the effect of further legislation, which is almost certain to come about, and by other unavoidable increases in expenses.

It appears from the tables submitted that coincident with increased property investment during the past three years, practically all of the railroads in this proceeding have largely increased the average tractive power of their locomotives and the carrying capacity of their cars, and have also made substantial increases in their train load, all of which has tended to more economical operation. Speaking more specifically, the Baltimore & Ohio company having made exceptionally large capital expenditures during the period last mentioned, was enabled to effect such increase in its freight train load as to result in a saving in the fiscal year 1913, when compared with 1910, of over 9,000,000 freight train miles, which, at an estimated cost of 50 cents per train mile, accomplished a saving in transportation costs of approximately \$4,500,000 per annum. This large saving, however, was more than offset by increases in other expenses, due to causes which I have already mentioned. I feel confident that the relief which is necessary if these carriers are to meet the standard suggested by the commission in its report I. C. C. 3400 is not to be found in more efficient operation.

We next come to the question of large increase in gross earnings. Under certain conditions it might properly be expected that larger gross earnings would give increased net, but it so happens that the railroads involved in this proceeding are located in that part of the United States where commercial and industrial development has been most intense, and it will be shown that in order to increase the gross earnings of these particular companies to any great extent at the existing rates, it would be necessary for them to handle a volume of business much beyond their present carrying capacity. It would, therefore, be necessary to obtain and spend a large amount of new capital for increased facilities before gross earnings could be greatly augmented, and as has already been shown, new capital invested in such facilities during the last three years has generally failed to earn any return whatever upon the investment. For this reason, I do not think we can safely look for relief in the one direction of increased gross earnings, and this brings us to the third remaining method suggested—that is, increased charges, or increased rates and fares.

Inasmuch as the passenger fares charged by these several companies are generally the result of legislative enactments, and the mail pay and express rates are also beyond the control of the railroads, it will be seen at once that no immediate relief and perhaps no very considerable relief at any time, can be obtained in these directions, and we are consequently forced to consider an advance of freight rates as the one available source of increased earnings. When this same question was before the commission in case I. C. C. 3400, it was strongly urged by shippers who opposed the increase at that time, that, if it should be shown that the carriers did need increased revenue, and if it should also appear that such increased revenue ought to be obtained by increased freight rates, such advance should not be obtained as was then proposed, by a very considerable advance of some of the rates, and no advance of others. It was pointed out that the rate structure, such as it was at that time, was the result of a long period of competition, plus the influence of many years of state and federal regulation, and that commercial and industrial conditions generally had grown up in harmony with the existing structure, and it was urged that the relation of rates between different places and between themselves, ought not to be violently or unnecessarily disturbed. The force of this argument has been recognized by the carriers, and in the present instance while it is proposed to secure the necessary increased revenue by an advance of freight rates, it is also proposed that it should be obtained by an increase generally of 5 per cent., using minima of 5 cents per ton and of one-quarter of a cent per cwt., preserving so far as possible existing competitive adjustments as between localities. This method takes full cognizance of the claim previously made by the shippers that the existing rate structure should not be unnecessarily disturbed so far as relation between rates is concerned.

The amount of advance, or the percentage of increase now pro-

posed, is, in the opinion of those who are parties to this movement, too small to properly meet the exigencies of the case. It was felt, when the matter was first discussed—and that feeling has been strengthened with the passage of time—that a 10 per cent. increase of freight rates was necessary and should be requested at the present time, and while all felt that 10 per cent. was not higher than the conditions justify, the lesser advance of 5 per cent. was finally determined upon, because it was recognized that the whole rate situation was a matter of delicate relationship, and the individual carriers were naturally solicitous that nothing should be done to disturb the free and well-established movements of traffic. An increase of 5 per cent., it was thought, would not be large enough to affect seriously, if at all, commercial adjustments, and the increased net which would be gained by such an advance, while not of itself equal to the necessities of the case, would in any event be of assistance, and, most important of all, the general increase of rates would serve to direct attention to the relationship which does and must exist between railroad charges and the total cost of operation.

It was urged in the previous hearing that the carriers at that time were unable to show by actual test that the rates in effect were insufficient, and that they failed to show the necessity for increased revenue. We believe that in the present case the evidence, showing the need of additional revenue, is ample. It was suggested also that even if additional revenue were necessary at that time, the plan proposed was not the right one by which to obtain it. The carriers accept that point of view, and now propose that the increased revenue be obtained by an advance of a small percentage of all rates in the territory affected. It is believed that the plan now submitted is the fairest and best one possible under all the circumstances.

In conclusion: I have shown that tendencies which have been operating over a period of at least ten years have resulted in such diminishing net returns that it has gradually come about that money invested in these railroads, because of the low average rates prevailing in so-called Official Classification territory, and for other reasons, does not earn the same return as money invested in other enterprises of similar kind or character. As a matter of fact, money so invested during the last three years, taken as a whole, has earned no return whatever. In view of all this, those responsible for the management of these properties would not be justified in continuing large expenditures of new capital for additional facilities and equipment, even if such capital were available at reasonable rates of interest.

I have also shown that the railroads in Official Classification territory have increased their property investment for new tracks, stations, locomotives, freight and passenger cars, and for other similar purposes at the rate of approximately \$200,000,000 per annum during the whole of the last ten-year period, and it is certain that the continued annual expenditure of a sum even greater than that will be necessary for similar purposes, if the carrying capacity of the railroads in this territory is to keep pace with the normal growth of commerce.

The immediate and all-important question is: How shall these railroads obtain the new capital necessary if they are to provide the needed facilities, and furnish the high-class service which the public interest demands, and to which the public is properly entitled? The answer, we think, is to be found in the following words, which appear in the report of this commission, from which I have already quoted:

We should allow such rates which will yield to this capital as large a return as it could have obtained from other investment of the same grade. If rates formerly in effect have become insufficient, then higher rates should be permitted. Commerce and industry cannot afford to wait on transportation facilities.

STATEMENT BY F. A. DELANO.

In the 1910 case, the commission reiterated a principle it had frequently applied in previous cases involving the reasonableness of competitive rates, which is tersely stated in the following sentence taken from the Spokane case:

"We must, therefore, in fixing rates, have regard not altogether

to any one particular railroad, but to the whole situation, and must consider the effect of whatever order we make upon all these defendants."

In applying this principle in the 1910 case, the commission held that the Pennsylvania, New York Central and Baltimore & Ohio systems were, for the purpose of measuring the reasonableness of rates, fairly typical of the railroads in Official Classification territory.

Mr. Willard has indicated in his statement that the lines generally will offer evidence which will show that they are now entitled, on the authority of that ruling, to increase their rates.

That ruling was no doubt justified by the evidence submitted in that case, but we, who represent the Central Freight Association lines, do not believe the evidence in that case fully developed the whole railroad situation in the territory.

We concur in all that Mr. Willard has said, and believe the evidence will show that the systems I have mentioned considered alone are entitled to an increase in rates, but we are not satisfied with the ruling of the commission that those systems are typical of the lines in the territory, and believe that if the ruling should be affirmed as a fixed precedent for future guidance, its application will cause irreparable injury, not only to them, but also to the people they serve, and we have accordingly determined to bring to the attention of the commission in the present case evidence which we believe will justify a reconsideration of the subject; and I have been delegated to briefly outline that evidence.

We will participate with the trunk lines in offering testimony on the general features of the case, and will confine our separate presentation to the submission of additional evidence which, we believe, will show the ruling of the commission, that the systems I have mentioned are fairly typical of the whole situation in the territory, ought not to become a fixed precedent, and that the "whole situation" in Central Freight Association territory is the fair measure of the reasonableness of the rates in that territory, and calls for a very substantial increase in rates.

Official Classification territory embraces three distinct and independent railroad territories and rate zones, which we will endeavor to show were created in a natural way in the evolution and development of the railroad business by economic conditions peculiar to each, but not common to two of them.

*New England Territory.*—First, we have the New England territory, which embraces the New England states, and contains an area of approximately 64,000 square miles, inhabited by approximately eleven million people, or 174 inhabitants to the square mile, and traversed by 8,071 miles of railway lines, which touch an average population, including New York City, of 1,389 per mile of railroad. The population of that territory is dense, and, in the main, assembled in large industrial centers, the rural population of the New England states being only 17 per cent. of the whole population.

That territory does not produce fuel or other raw material, except granite, marble and lumber—and those do not comprise a substantial tonnage—and, while the traffic is dense, it consists largely of merchandise, manufactures, and miscellaneous. For instance, approximately 45 per cent. of the tonnage of the two principal railroads in that territory, during the year 1912, consisted of that class of traffic.

The hauls in that territory are short. Little traffic passes through, except imports and exports, and the bulk of the traffic originating or destined beyond that territory is received from or delivered at its west boundary to lines running west and south, while the water-borne tonnage is largely hauled but short distances to inland towns.

These conditions, and the isolated location of that territory along the Atlantic seaboard, water competition and numerous other economic influences peculiar to it, which the evidence will bring out more in detail, have created a railroad territory and fabric of rates and traffic conditions peculiar to it and independent of the West and South.

*Trunk Line Territory.*—We have next the Trunk Line terri-

territory, which embraces the area west of the Hudson river and the Atlantic seaboard, north of the Potomac river and east of what is known as the "Western Termini"—a line extending from Buffalo through Pittsburgh to the Ohio River. This territory embraces an area of 112,000 square miles, and has a population of twenty-one million, or 207 inhabitants to the square mile, and is traversed by 23,777 miles of railway lines, which touch an average population of 889 per mile of railroad.

As in the New England territory, the population in the Trunk Line territory is found largely in its great cities—the rural population of the States included in the territory being only 30 per cent. of the whole.

The area and population of this territory are greater than the area and population of the New England territory, but the area per mile of railroad is only about one-half, which indicates that the former is more amply supplied with railroad transportation facilities than the latter. While the population per mile of railroad is greater in New England territory than in Trunk Line territory, the tonnage in the latter, per mile of railroad, is approximately twice the tonnage in the former. The character of the traffic is likewise substantially different in the two territories. For instance, the combined tonnage of products of mines carried by the Pennsylvania Railroad proper, the New York Central proper, and the Baltimore & Ohio system in 1912 was approximately 10 times the same class of tonnage carried by the two principal railroads of New England. That class of tonnage comprised 66 per cent. of the total tonnage of the Pennsylvania and the Baltimore & Ohio, but only 30 per cent. of the total tonnage of the two New England roads.

The evidence will show that Trunk Line territory comprises relatively the largest population per square mile, the greatest industrial activity, and the densest traffic of any similar area in the country. It embraces the great manufacturing centers of New York, New Jersey and Pennsylvania, and the Pittsburgh district—the greatest tonnage center in the world.

In the early history of railroad building in that territory, the railroads were built westward from New York and other Atlantic seaboard cities on the south, and either terminated at Buffalo, on the Lakes, or at Ohio river cities. The rates were made applicable to these lines as originally constructed, and the character of the traffic, physical surroundings and other economic influences, which we will point out more in detail in the evidence, built up and have preserved to this day a railroad territory and a fabric of rates and traffic conditions peculiar to it and independent of and distinct from the territory east, west and south of it.

*Central Freight Association Territory.*—The remainder of Official Classification territory—the vast area extending from Trunk Line territory to the Mississippi river and the Lakes—comprises what is known as Central Freight Association territory.

The portion of that territory in the United States contains an area of approximately 186,000 square miles, inhabited by about nineteen millions of people, or 122 inhabitants to the square mile, as compared with 207 in Trunk Line territory and 174 in New England territory, and is traversed by 35,849 miles of railroad, which touch an average population of 506 per mile of railroad, as compared with 889 in Trunk Line territory and 1,389 in New England territory.

It will be noted that, while this territory contains two million less population than Trunk Line territory, its area is 74,000 square miles greater, and is traversed by 12,072 more miles of railroad, and while it contains about eight million more inhabitants than New England territory, it comprises more than three times the area and is traversed by 27,778 more miles of railroad.

The population of the principal states in Central Freight Association territory is about equally divided between the cities and the rural sections, the percentage of rural population being 46 per cent. of the whole. But it does not follow that it has too many railroads or too much mileage, because, as we have seen, the population is thinly spread over 186,000 square miles, as compared with a two-million greater population in Trunk Line

territory assembled on 112,000 square miles, and only eight millions less population in New England territory assembled on 64,000 square miles.

The traffic in this territory is diversified and very general in character, and is substantially different in many respects from the traffic in the other territories.

This territory was created largely by physical conditions and natural development and growth of population. Its numerous lakes and rivers, some of which form its boundaries, attracted to their borders the early settlements and cities, and in time came Chicago and St. Louis, its two chief centers of population. The territory is comparatively level, which facilitated railroad building, and as population increased, railroads were constructed in all directions, the objective points being, naturally, lake and river cities.

It is a well-known fact that in the development of that territory water competition has always been an important factor, and that the railroads have promoted the growth of population and industrial development by low rates. Again, railroad building at times has been in excess of the growth of the country, and caused abnormal competition, resulting in lower rates.

At the time the government entered upon the regulation of rates, those prevailing in Central Freight Association territory, as a body, were comparatively the lowest rates prevailing in any section of the country, and in recent years they have been still further reduced—and especially passenger fares, which have been reduced from 3 to 2 cents per mile, or 33 1/3 per cent.—in all the states in that territory.

The influences I have mentioned, which we will show in detail in the evidence, have resulted in the bankruptcy of a substantial portion of the railroad mileage in the territory and in depleting the earnings and debilitating the credit of the remaining lines to an extent which, unless relieved by prompt and substantial advances of rates, will naturally result in impeding the commerce and transportation of that section of the country.

On the evidence, we will urge that, owing to the different conditions existing in these three component parts of Official Classification territory, lines traversing two of these sections ought not to be regarded as typical of the whole situation in the territory or in the component parts. Undoubtedly a great many important considerations are common to all the lines in the three component parts, and accordingly the showing of the Pennsylvania, Baltimore & Ohio, and New York Central systems will be of great value to the commission. We do not mean to disparage, or in any way discredit, the showing of those systems, but merely contend that their showing is not conclusive or typical of the entire situation.

We believe it will be pertinent to show the conditions prevailing in Central Freight Association territory, and will, therefore, offer in evidence, among other things, statements of the mileage, earnings, and results of operation of the lines located therein, with a view of indicating the "whole situation" in that territory.

There are, in the territory, 35,849 miles of railroad (exclusive of the mileage of switching and terminal companies) owned by 93 companies.

We have omitted switching and terminal companies because they perform a special service on an arbitrary basis, generally fixed on a per-car rate.

The mileage, however, includes the mileage in C. F. A. territory of the Mobile & Ohio; St. Louis, Iron Mountain & Southern; Louisville & Nashville; Southern Railway; St. Louis Southwestern; Chicago, Burlington & Quincy, and Norfolk & Western—1892 miles, or 5.3 per cent. of the total—but we exclude that mileage from our figures, because it is only 7 per cent. of the mileage of those companies, and the results of their operation cannot be segregated. As 93 per cent. of the mileage of these companies is in higher rate zones, it is obvious that the operations of these companies as a whole would be immaterial.

This leaves 33,957 miles of railroad, or 94.7 per cent. of the total, in the territory.

In presenting our figures we will be obliged to add to that



mileage the results of the operation of 264 miles of the Chicago & Alton; 2,628 miles of the Illinois Central, and 859 miles of the Wabash. The principal operation of these three companies is in the territory, the 3,751 miles outside being west of the Mississippi river or south of the Ohio river, in higher rate zones, and we include them because the results of operation of the mileage in the territory cannot be segregated.

We will also include 3,401 miles of the Baltimore & Ohio and Erie, which are located in Trunk Line territory, because the operation of this mileage cannot be segregated from their lines in the territory.

Our figures will, therefore, embrace the results of operation of 41,109 miles of railroad, and we will arrange them in four groups:

*Group One*—Embraces the 41,109 miles of railroad I have mentioned, except 6,443 miles of Erie lines east of Marion, Ohio, and the B. & O. system, and 2,729 miles—the aggregate mileage of 46 short railroads in the territory, which, together, earned less than eight million dollars in 1910.

*Group Two*—Embraces the Erie lines east of Marion, Ohio, and B. & O. system, aggregating 6,443 miles, 3,401 of which is located in Trunk Line territory. This mileage is grouped together because the results of operation of the mileage in C. F. A. territory cannot be segregated.

*Group Three*—Embraces 28 of the 38 roads in group one, with an aggregate mileage of 23,167 miles, which includes 19,416 miles, or 51½ per cent. of the entire mileage in the territory, and embraces such important lines as the Big Four system; the Vandalia; the Chicago & Eastern Illinois; Nickel Plate; Grand Trunk Western; Grand Rapids & Indiana; Pere Marquette; Cincinnati, Hamilton & Dayton; Illinois Central; Chicago & Alton, and Wabash.

*Group Four*—Embraces 46 companies with an aggregate mileage of 2,729 miles, or 7½ per cent. of the total mileage in the territory, which, together, in 1910 earned less than eight million dollars. These roads are important factors in the development and commerce of the respective communities they serve, but, as a rule, they are in great financial distress, and, being short lines, we thought it natural to group them together.

We believe that group three embraces lines which are fairly representative of the whole railroad situation in the territory, and for that reason we will refer to it in some detail.

We have omitted from this group the main line connections of the Trunk Line systems—the Lake Shore, the Michigan Central, the Pennsylvania company, and the Panhandle—although the figures will show that their prosperity has been substantially impaired during the last few years by a constantly increasing ratio of expense to earnings.

The fact, however, that this mileage as a whole was constructed at a very low capital charge and forms integral parts of the best and strongest railway systems of the country, to say nothing of the credit and business they have enjoyed from their affiliations and the returns on their outside investments, place them in a class by themselves. These facts (which will be shown more in detail in the evidence) will conclusively prove that, while those lines, no doubt, need an increase in rates, they do not belong in the group of railroads which fairly represents the railroads in the territory.

We have also excluded from group three the Pittsburgh & Lake Erie, Bessemer & Lake Erie, Hocking Valley, Kanawha & Michigan, Toledo & Ohio Central, and Wheeling & Lake Erie. These roads are located in a comparatively small area between the Great Lakes and the iron furnaces and coal mines of Ohio, and their traffic is not of a general nature, but substantially confined to the products of mines; their tonnage of these products during 1912 being 78.6 per cent. of their entire tonnage, but the exceptional feature of their situation lies not only in the volume of this mineral traffic, but in the fact that by reason of hauling iron ore in one direction and coal in the reverse way, they have a balanced traffic, which produces an unusually favorable operating condition.

While these lines are within the boundaries of the territory, they do not enter into the general railroad situation and cannot be included in a group of roads fairly representative of all the railroads in the territory.

We have also excluded from group three the 46 short lines whose aggregate earnings for 1910 were less than eight million dollars, because, as we have said, those lines are short, their earnings are small, and they are, as a rule, in financial distress and ought not to be included in a group of roads representative of the railroads in the territory.

We have included in group three 28 companies with an aggregate mileage of 23,167 miles, which traverse all parts of the territory and participate in the general traffic of that section of the country.

We believe a mere glance at the map of this large mileage (23,167 miles) will indicate that it is fairly representative of the territory. In any event, we may be assured that if this mileage is not influential in determining the reasonableness of rates, the prosperity, commerce, and development of the whole territory will be placed in jeopardy.

*Salient Facts from the Evidence.*—On the evidence we will present, in detail, our contentions, but my present purpose will be served by merely calling your attention to a few salient facts.

This great network of railroads covering the entire territory, during the year ending June 30, 1910, earned 239 million dollars, and during the year ending June 30, 1913, 275 million dollars, or a gross increase of about 36 million dollars; but in the former year the operating expenses and taxes were 182 million dollars, and in the latter year, 227 million dollars, or an increase in expenses of about 45 million dollars, resulting in a decrease in net revenues, after payment of taxes, of over nine million dollars, and in net corporate revenue of more than 16 million dollars.

As stated in other words, the ratio of operating expenses and taxes to earnings, during the same period, increased from 76.3 per cent. to 82.8 per cent.

These same roads, during the year ending June 30, 1908 (which will be remembered as a panic year), earned 212 million dollars, and during the year ending June 30, 1913, 275 million, or an increase of 63 million; but, during the year ending June 30, 1908, the operating expenses and taxes were 165 million, and the year ending June 30, 1913, 227 million—an increase of about 62 million.

Now, despite the fact that during that same period more than 175 million dollars were put into additions and betterments, the net after deducting operating expenses and taxes showed an increase of only \$800,000, while the net corporate income actually decreased about eight million dollars.

As we have shown, this mileage comprises 51½ per cent. of the entire mileage in the territory, and if we add the mileage of the 46 short railroads, we will have 59.1 per cent. of the entire mileage of the territory, all of which is in a deplorable financial condition.

While, as we have said, the evidence will show the lines embraced in group three are fairly representative of the whole situation in the territory, the lines embraced in group one show a result almost equally deplorable, especially in the last few years.

Group one, as we have seen, embraces 78.6 per cent. of the entire mileage in the territory, including all the strong lines, and, besides, 3,751 miles outside of the territory in higher rate zones; and excludes only the 46 short lines which are in financial straits, and the Erie east of Marion, Ohio, and the B. & O. system, and the short projections of southern lines into the territory.

Group one, in the fiscal year 1910, earned \$457,000,000, and in the fiscal year 1913, \$533,000,000, or showed an increase of \$76,000,000; but operating expenses and taxes during the former year were \$329,000,000, and during the latter year \$417,000,000, or an increase in expenses and taxes of \$88,000,000, resulting in a decrease in net revenue, after deducting operating expenses and taxes, of \$12,000,000, and a decrease in net corporate income of \$17,500,000.

These large decreases resulted in the face of the investment of

vast sums of new money for additions and betterments—in other words, notwithstanding the investment of this new capital, the ratio of operating expenses to gross revenue increased from 72 per cent. in 1910 to 78.2 per cent. in 1913.

The figures for the first two months of the present fiscal year are still less encouraging; for instance, the net revenue, after deducting operating expenses and taxes of the lines in group one for the two months mentioned, decreased about \$4,500,000 as compared with the same two months last year, while the decrease of the lines in group three was about \$2,000,000, as compared with the same months last year.

The evidence will show that the lines in Central Freight Association territory are confronted with the expenditure in the near future of millions of dollars in the separation of grades in various cities, on which they will receive no adequate return, and many of the lines have not the credit to raise this money. This circumstance, in view of the present conditions of the roads, presents a serious situation which calls for prompt relief.

It will be obvious from the evidence that a 5 per cent. increase in rates will not be adequate to meet the demands of the territory. As I have said, the rates in that territory, both freight and passenger, are the lowest rates prevailing in the United States, and the interests of the people of that rapidly growing and developing section of the country, to say nothing of the carriers, require, in the near future, a readjustment of the rates, both freight and passenger, to a basis which will enable that territory to have good railroads and the people to have efficient and adequate service, and to progress measurably with the other sections of the country.

FINANCIAL AND OPERATING ELEVEN-YEAR STATEMENTS.

In report I. C. C. 3400, emphasis was placed on the fact that in the case of the larger lines, the systems in their entirety, and not individual roads composing same, should be considered. Consequently the committee arranged that the reports be made as systems so far as possible. There is now filed a combined statement of 35 roads and systems, the mileage of which is about 80 per cent. of the entire mileage in Official Classification territory, and includes also considerable mileage which extends beyond this immediate territory.

These roads combined own 53,670 miles of line and operate 58,275 miles of line.

The combined property investment at June 30, 1913, is \$6,280,571,000, or \$117,022 per mile of line, and \$58,189 per mile of all tracks. Between 1903 and 1913 these roads added to their property investment \$1,980,093,000, or an increase of 46.04 per cent.

The total operating revenue, which was, in 1903, \$870,783,000, rose to \$1,424,119,000 in 1913, an increase of over \$553,000,000, or 63.54 per cent. Taxes paid by these roads in 1913 aggregated \$54,494,000, or 111.44 per cent. more than was paid in 1903. Operating expenses, including taxes, hire of equipment and rents, increased 1913 over 1903, \$464,154,000, or 77.15 per cent., so that net operating income increased only \$85,317,000, or 33.93 per cent.

Comparing 1913 with 1910, the combined property investment increased \$659,862,000, while operating revenue increased \$186,775,000. Including taxes, which increased over \$11,580,000, expenses increased more than \$203,087,000, so that net operating income decreased \$16,311,000, or nearly 5 per cent. In other words, after increasing investment 11.74 per cent. and gross revenues 15.09 per cent., there was no resultant increase in net income; on the contrary, there was realized \$16,311,000 less net than was earned before over \$650,000,000 was added to the property investment.

The per cent. of return on property investment was, for the five-year period to 1907, inclusive, 5.96 per cent., and for the second five-year period to 1912, inclusive, only 5.50 per cent. The average return for the ten-year period to 1912, inclusive, was 5.71 per cent., and that for 1910 6.28 per cent., compared with 5.23 per cent. in 1911, 5.19 per cent. in 1912, and 5.36 per cent. in 1913.

It is especially notable that whereas heretofore in periods of high operating revenues, the per cent. of return has been highest, as in 1907 and 1910, when it was 6.25 and 6.28, respectively, in 1913, when the highest revenues in the history of this group of roads were made, the return was only 5.36 per cent.

The per cent. of return of net corporate income, plus interest on total capital obligations, shows the same general tendency downward.

In view of the widely scattered mileage and great divergence in conditions, in different sections of the territory and during the various periods, it is realized that no close deductions can be made from the combined figures of these roads. It is clearly evident, however, that there has been a persistent narrowing of the margin between income and outgo.

Comparing 1913 with 1903, operating revenues increased \$553,336,000, or 63.54 per cent., while operating expenses and taxes increased \$466,088,000, or 76.35 per cent. The increase in operating revenues in 1913 over 1910 was \$186,775,000, or 15.09 per cent., but operating expenses increased \$189,722,000, or 22.79 per cent.

The total increase in expenses 1913 over 1903 is distributed through the several accounts as follows:

	Amount of increase.	Per cent. of increase.
Maintenance of way .....	\$65,149,000	56.46
Maintenance of equipment.....	125,901,000	104.12
Transportation and traffic.....	207,827,000	64.59
General .....	38,490,000	144.59
Taxes .....	28,721,000	111.44
Total .....	\$466,088,000	76.35

The ratio of operating expenses to total operating revenues, which in 1910 was 67.27 per cent., was in 1911 70.71 per cent., in 1912 70.75 per cent., and in 1913 71.77 per cent. For the five-year period to 1907, inclusive, the ratio was 67.84 per cent. and for the five-year period to 1912, 69.55 per cent. The ratio for the ten-year period to 1912, inclusive, was 68.78 per cent., compared with 71.77 per cent. in 1913.

In each of the three years since 1910 the total operating revenues were in excess of the 1910 figures, but in each of those three years net operating revenue and net operating income were less than in 1910, so that in this period there has been no increased return whatever for the interest charges on the new capital which provided the additional facilities required to handle the greater volume of business.

COMBINED STATEMENTS.

In I. C. C. 3400, emphasis was placed on the fact that, in the case of the larger lines, the systems in their entirety and not the individual roads composing same should be considered. Special consideration was given by the commission to the results of operations of the New York Central, the Pennsylvania and the Baltimore & Ohio Systems.

All intercorporate system ownerships and dividends on stock and interest on funded debt paid and received for such intercorporate holdings have been eliminated. The figures shown, therefore, in all cases are the results after such elimination.

Property investment is the book value of the railroad property used in the public service, the income and expense attached to which is covered in the operating income.

*Lines Included:* The properties covered by the accompanying statements are those owned, operated and controlled by the above companies. Some corporations, owned jointly with others, principally terminal companies, have been excluded.

These systems comprise 28,395 miles of operated road, and 60,697 miles of all tracks operated, or about 47.86 per cent. and 52.47 per cent. of the road and the track operated, respectively, in the Official Classification territory. Their gross operating revenue for the year was \$797,362,913, or 57.53 per cent. of the total earnings of roads in the territory under consideration. The property investment of these systems at June 30, 1913, aggregated \$3,253,431,204.

The property investment, which represents the book value of the investment in road and equipment, in 1913 was \$3,253,431,204

or a sum \$1,107,335,816 greater than it was at the close of 1903, an average increase of over \$110,000,000 per annum. In the three years since 1910 the increase was \$423,431,094, an average each year of over \$140,000,000.

Property investment per mile of road rose from \$81,476 in 1903 to \$119,275 in 1913, and for all tracks from \$44,761 to \$55,403.

In the ten years between 1903 and 1913 these systems added to their plant 10,777 miles of all tracks, of which about 1,000 miles was first main track. In the three years since 1910, the miles of all track have increased 2,801 miles, or 5.01 per cent., while the increase in first main track was but 214 miles—showing that the development in this period has been intensive in character.

Coincident with this expansion of facilities and large increase in property investment to which I have referred, there has been a notable increase in business.

The number of tons carried one mile, which in 1903 was 55,134,587,820, had in 1913 reached the total of 91,638,907,564, an increase of 36,504,319,744, or 66.21 per cent., while passengers one mile showed an increase of 55.80 per cent. Comparing 1913 with 1910, there was an increase in passengers carried one mile of 12.99 per cent., and an increase in tons carried one mile of 17.03 per cent.

In the period 1903-1913 gross earnings rose from \$488,143,821 to \$797,362,913, the earnings for the year 1913 being the greatest in the history of these lines, an increase of \$309,219,092 over 1903, and of \$109,380,362 over 1910.

The net operating income, which in 1903 was \$133,352,650, and in 1910 reached \$181,479,024, was in 1913 only \$173,098,314, an increase over the year 1903 of \$39,745,664, but actually \$8,380,710 less than it was in 1910.

While the property investment in 1913 increased \$1,107,335,816 over 1913, or 51.60 per cent., and the business handled, as reflected in the gross earnings, increased by \$309,219,092, or 63.35 per cent., the net operating income increased \$39,745,664, or only 29.80 per cent. In other words, the increase of net operating income represented a return on the new investment of 3.59 per cent. only.

Comparing 1913 with 1910, the property investment increased \$423,431,094, or 14.96 per cent., the operating revenue increased \$109,380,362, or 15.90 per cent., while net operating income shows a decrease of \$8,380,710. That is with an increase of 14.96 per cent. in property investment and 15.90 per cent. in operating revenue, there was an actual decrease in net operating income of nearly \$8,500,000, not merely was there no net to meet the new capital, but there was an absolute shrinkage of already existing net income.

#### THE PENNSYLVANIA SYSTEM.

The following is an abstract of memoranda filed by C. M. Bunting in connection with the ten-year statements of the Pennsylvania System:

These statements cover all railroad corporations controlled, affiliated in interest, and operated as a part of the Pennsylvania System East and West, and therefore do not include certain roads noted upon the analysis accompanying the statements, which are not a part of the system, though the Pennsylvania has some stock interest therein.

The capital obligations in the statements include only those owned by the public or by other companies outside the system.

In property investment, the entire amount for each company in the system has been included as this total represents investment in the plant devoted to public use. In this way, the comparison of net operating income with property investment and net corporate income with capital stock outstanding, is a true reflection of actual facts from such viewpoint.

The first and one of the most important features is the property investment account, which represents the book value of the investment in road and equipment. The return on property investment shows a declining tendency since 1903

and a steady decline since 1910. Thus between 1903 and 1913 there has been an increase in property investment account of \$530,750,073, and an increase in net operating income of \$11,860,533, or only 2.23 per cent. on the increased property investment. Indeed, between the years 1910 and 1913 there was an increase of \$207,186,919 in the property investment and a decrease in the net operating income of \$11,485,511. In other words, the Pennsylvania system was \$11,485,511 short of even receiving one cent additional return on its enlarged investment. The percentage of return on property investment in 1903 was 7.49 per cent.; in 1910 it was 7.41 per cent., and the average for the ten years, 1903 to 1912, inclusive, was 6.81 per cent., while in 1913 it had fallen to 5.48 per cent.

The miles of first main track owned have increased, 1903 to 1913, only 3.92 per cent., while the miles of all tracks owned have increased in the same period 23.07 per cent., indicating that the development is intensive rather than extensive.

#### NET CORPORATE INCOME.

The net corporate income per cent. of capital stock was 14.07 per cent. in 1903, 13.17 per cent. in 1910 and 9.64 per cent. in 1913, or a drop of nearly one-third between 1913 and 1903, and of over one-quarter between 1913 and 1910.

#### DIVIDENDS.

The dividends paid (per cent. of all stock outstanding), were as follows:

1903.	1910.	1913.
5.62 per cent.	6.53 per cent.	5.67 per cent.

The annual surplus after payment of interest and dividends is the system's margin of safety. This has declined as follows:

PER CENT. OF TOTAL OPERATING REVENUE.		
1903.	1910.	1913.
12.55 per cent.	10.40 per cent.	6.39 per cent.

PER CENT. OF TOTAL CAPITAL OBLIGATIONS.		
1903.	1910.	1913.
3.71 per cent.	2.91 per cent.	1.99 per cent.

The total capital obligations of the Pennsylvania System June 30, 1913, \$1,231,138,848, show an increase of 55.87 per cent. over the amount outstanding June 30, 1903, and during that same period the net corporate income has been reduced from 14.07 per cent. on the capital stock to 9.64 per cent. In view, however, of the fact that in recent years there have been considerable conversions of bonds into stock, thereby necessarily reducing the rate earned on the stock, it will be of interest to see the percentage relation for these periods between the net corporate income (plus interest on funded debt) and the total capital obligations. The net corporate income (plus interest on funded debt) per cent. of total capital obligations was 8.74 per cent. in 1903, 8.18 per cent. in 1910, with an average for the ten years 1903 to 1912 of 7.44 per cent. It has fallen to 6.88 per cent. in 1913, being a decrease of over one-fifth in ten years.

It should be noted also, in this connection, that as these figures are made up for the years ended June 30, the total capital obligations include capital stock which was issued during the fiscal year, but which did not participate in the dividend within such years. Making the adjustment for this, the net corporate income (plus interest on funded debt) was in 1903, 8.98 per cent.; in 1910, 8.54 per cent., and in 1913, 7.12 per cent. on total capital obligations.

The operating revenues of 1913 increased \$47,057,640 over 1910, but as the operating expenses increased \$54,492,139 and taxes \$4,079,779, there was a decrease in the net operating income of \$11,485,511, notwithstanding an increase of \$207,186,919 in the property investment account.

The average revenue per ton per mile decreased in this three-year period from 6.16 mills to 6.06 mills, and the average revenue per passenger per mile increased from 1.815 cents to 1.825 cents; the net result of the two being, on the

1913 traffic, equivalent to a decreased revenue of \$3,828,569. Even admitting that the decline in freight revenue per ton mile may be partly due to a change in the character of the traffic handled, the loss in revenue of \$3,828,569 remains an actual fact. The increase in expenditure is equally an actual fact, both in dollars and when worked out as cost per traffic unit.

The following table shows that per million traffic units (ton miles plus passenger miles) the receipts were \$48.68 less and the expenses were \$417.34 more. The result is the profits are less by more than \$500 per million traffic units, and the Pennsylvania System handled 47,463,335,288 traffic units in 1913.

PER MILLION TRAFFIC UNITS.	1910.		Increase or Decrease.
	1910.	1913.	
Total operating revenues.....	\$8,106.46	\$8,057.78	D. \$48.68
Operating expenses:			
Maintenance of way and structures..	1,029.04	1,132.48	I. 103.44
Maintenance of equipment.....	1,406.65	1,537.44	I. 130.79
Transportation and traffic.....	2,837.44	3,028.79	I. 191.35
General.....	198.30	201.18	I. 2.88
Outside operations.....	223.76	212.64	D. 11.12
Total operating expenses.....	5,695.19	6,112.53	I. 417.34
Net operating revenue.....	2,411.27	1,945.25	D. 466.02
Taxes.....	269.96	321.28	I. 51.32
Hire of equipment, rents, etc.....	27.03	22.96	D. 4.07
Net operating income.....	2,114.28	1,601.01	D. 513.27

The amount of wages paid has increased about \$36,000,000 during the period 1910 to 1913, approximately \$15,000,000 of which is due to increased rates of pay, and this is distributed throughout all accounts, and is responsible for a portion of the increase in the maintenance of way and structures and maintenance of equipment expenses. In addition large expenditures had to be made in these accounts for more substantial and heavier equipment, the higher standard of road-bed all through, more ties, installation of tie plates, deeper ballasting to take care of the heavier equipment and extension of and more modern interlocking.

There has also been an increase in the average number of tons per loaded car of 1.02 tons, and an increase in the average daily mileage of freight cars (System East) from 25.80 to 27.35 per car.

Transportation expenses are affected to a greater degree than other departments of expense by increases in wages, and they also have the added burden of the cost of hours of service law, the cost of extra crew laws and increased cost of fuel. On the other hand, transportation expenses have been kept down by the increased lading per car, the increase in the train load and the decrease in the number of pounds of fuel per thousand ton miles, most of which, except possibly the latter, has been made possible through the additional outlay represented in property investment account.

	1903.	1910.	1913.
Tons per loaded car mile.....	21.14	24.69	25.71
Train load (tons).....	436.32	523.21	582.00
Pounds of fuel consumed per 1,000 traffic ton miles.....	765	732	727

Taxes have increased \$4,079,779 as between 1910 and 1913, and there has been an increase in taxes per mile of first main track, per mile of all main tracks, per mile of all tracks, as well as an increase in the ratio to total operating revenue, and a still greater increase in the ratio to net operating revenue.

The result compared with 1910 of the increase in expenses, which is greater than the increase in operating revenue, is a decline of \$11,485,511 in net operating income in 1913, notwithstanding an increase of \$207,186,919 in the property investment account for the same period.

Summing up the operations we have, comparing 1913 with 1910, an increase in tonnage, but a decrease in the average revenue per ton mile, an increase in operating revenues of 14.03 per cent., an increase of 23.13 per cent. in operating expenses, an increase of 36.53 per cent. in taxes, and a decrease of 13.13 per cent. in net operating income, with an increase of 17.56 per cent. in the property investment account.

COMPARISON, 1913 WITH 1910.

	Amount.	Per Cent.
Property investment.....	\$207,186,919	I. 17.56
Operating revenues.....	42,057,640	I. 14.03
Operating expenses.....	54,492,199	I. 23.13
Taxes.....	4,079,779	E. 26.53
Net operating income.....	11,485,511	D. 13.13
Traffic units.....	6,090,583,461	E. 14.72

Even if the total freight revenues of the Pennsylvania System in 1913 had been greater by 5 per cent., the return from operations upon the property investment would have been 6.42 per cent.—or only about 1 per cent. greater than the percentage actually realized. The return from operations even then—including 5 per cent. additional—would still have been nearly \$14,000,000 short of the amount necessary to give the same return upon the property as that earned in 1910—namely, 7.41 per cent.

OTHER ROADS' STATEMENTS.

Statements similar to that of the Pennsylvania were presented by W. C. Wishart for the New York Central Lines and G. M. Shriver for the Baltimore & Ohio.

TUESDAY'S PROCEEDINGS.

The principal witnesses on Tuesday were Professor Frank Haigh Dixon, of Dartmouth, and statistician of the Bureau of Railway Economics; C. C. McCain, chairman of the Trunk Line Association; E. Morris, chairman of the Central Freight Association, and W. C. Maxwell, of the Wabash.

Mr. Maxwell's testimony was a detailed filling in of the outline suggested by Mr. Delano on Monday to show the effect of the increased expenses since 1903 and 1910. Mr. Maxwell showed that in no case was a fair return being earned on new capital invested either since 1903 or 1910, and in the majority of cases no return whatsoever was being earned on this new capital, despite very large increases in the business handled and in the gross receipts. Cross examination was confined to general questions as to how figures were compiled and as to whether or not the figures could be checked from returns made to the Interstate Commerce Commission. Mr. Maxwell testified that in most cases the figures had been compiled from the same sources as were used to furnish the returns to the Interstate Commerce Commission, and in most cases the compilation was made by his own office force under his personal supervision. In a few instances the Bureau of Railway Economics was relied on for figures. Counsel for the coal shippers who is apparently acting with Mr. Brandeis asked the significant question "Would it be possible from the detailed exhibit of increases in cost of material to determine from whom these materials were bought." Witness said that this could be done only from an examination of the detailed records of the purchasing officers of each of the roads.

Prof. Dixon submitted a statement showing increases in train load, car loading and other units of efficiency from 1903 to 1913, and from 1910 to 1913. Mr. McCain described the method of arriving at the 5 per cent. increase which can be illustrated as follows: New York to Chicago first class rate advanced 5 per cent. New York to Cleveland rate advanced the same number of cents per 100 lbs., so as to keep it the same number of cents less than the Chicago rate that it now is. In other words all differentials were preserved upon a cents per 100 lbs, or per ton basis and not on a per cent. basis; thus some rates were raised more than 5 per cent., some less. In Mr. McCain's opinion the grand total was very close to exactly 5 per cent. Mr. Morris described the method followed in Central Freight Association territory, which also preserved the differential in cents per 100 lbs.

The date for the next hearing has been set for December 10.

ROLLING STOCK IN SPAIN.—There are now in use on the railways in Spain: Passenger locomotives, 330; freight, 1,223; combined passenger and freight, 830; a total of 2,383. Passenger cars of all classes number 6,075, while of the 46,675 freight cars 1,905 are used for baggage and fruit transportation, 19,264 are box cars, and 25,506 are gondolas and flat cars.

## W. W. FINLEY.

William Wilson Finley, president of the Southern Railway, died suddenly of apoplexy at his home in Washington on Tuesday afternoon. Mr. Finley succeeded Samuel Spencer, as president of the Southern Railway, in the latter part of 1906, Mr. Spencer having been killed in a rear collision on Thanksgiving Day of that year. Mr. Finley took the Southern from the verge of bankruptcy and established it in a position of sound credit. He fully realized that the problem before the Southern was to develop the territory along its lines and, possessing all the enthusiasm of a natural born traffic promoter he put his whole soul into the development of the South, probably doing more for it during the past 15 years than any other one man. The mark of his faith in his country is seen in every county through which the Southern runs. The wealth that the carrying out of his ideas by the farmers and planters of the South has produced is one of the finest tributes to a railroad man that such an officer has ever earned.

Though primarily a traffic man, Mr. Finley was loved and respected by every operating officer of the road. Nothing could have been more fortunate for the Southern than to have as its president a traffic man, for the problem of building up the traffic in that territory was the greatest one with which the directors were confronted. In meeting this a strong land and industrial department was built up which carried out an extensive campaign for the improvement of agricultural conditions, particularly in the cotton belt. Experts were employed by the company to help the farmers combat the boll weevil. Demonstrations were made to the farmers, not on experimental or demonstration farms under specially favorable conditions, but on their own farms, with their own resources. President Finley was a believer in publicity and gave a considerable amount of his time to making addresses before commercial and industrial organizations with a view to securing closer co-operation between shippers and carriers. These addresses showed study, broad judgment and a frankness which convinced the farmers and manufacturers that the friendship of the railroad was sincere.

Mr. Finley was born at Pass Christian, Miss., September 2, 1853. He was educated in the public schools of that place and on May 1, 1873, entered the service of the New Orleans, Jackson & Great Northern and the Chicago, St. Louis & New Orleans as stenographer to the vice-president. After three years' service in this position he was for nine months secretary to the receiver; secretary to the agent for the trustees for one year, chief clerk, general freight department, for four years, and assistant general freight agent for three years. From March 1, 1883, to December 15, 1885, he was assistant general freight agent of the Texas & Pacific division of the Missouri Pacific, and from that time to July, 1886, was assistant general freight agent for the receiver of the Texas & Pacific. He

was then appointed general freight agent, which position he held until September, 1888, when he took the position of general freight agent of the Pan Handle Route, comprising the Fort Worth & Denver City, the Denver, Texas & Fort Worth and the Denver, Texas & Gulf.

In May, 1889, Mr. Finley was made chairman of the Trans-Missouri Traffic Association at Kansas City, Mo. From October 1, 1890, to May 20, 1892, he was chairman of the Western Passenger Association at Chicago. He then entered the service of the Great Northern as general traffic manager. He left this position April 10, 1895, to become commissioner of the Southern States Passenger Association at Atlanta, Ga. He first became associated with the Southern Railway on October 1, 1895, as third vice-president. On May 15, 1896, he returned to the Great Northern as second vice-president, but remained with that road only four months, returning in September to the Southern as second vice-president. On December 5, 1906, he succeeded to the presidency of the Southern, which he filled to the time of his death. In addition he was president of the controlled lines—the Alabama Great Southern; Cincinnati, New Orleans & Texas Pacific; Georgia Southern & Florida; Mobile & Ohio; Northern Alabama; Southern Railway in Mississippi, and Virginia & Southwestern.

Mr. Finley is survived by his wife, three daughters and a son, the latter being connected with the Pennsylvania Railroad. In 1910 the University of Tulane conferred on President Finley the degree of LL.D. He was chairman of the board of directors of the Bureau of Railway Economics at Washington and was a director of the Chicago, Indianapolis & Louisville Railway, of the Old Dominion Steamship Company and several other enterprises.



W. W. Finley.

On the track, I take peculiar pleasure in witnessing the operation of any apparatus or contrivance for clearing snow or ice from the rails. Being at Newark on Monday last, I had the pleasure of witnessing the performance of a very simple contrivance of L. A. Sykes, the engineer of the New Jersey Railroad which far surpassed anything of the kind I ever before saw, both in regard to its simplicity and its effective operation. The apparatus consists simply of a pair of bars or levers attached to the front end of the engine and standing nearly in an upright position and operated upon by a rope or cord. It is used without the least possible danger even at the greatest speed and is so small that it can be conveniently carried at all times upon the engine or tender car and can be easily attached or detached at any time in one or two minutes. Railroad managers or superintendents will do well to call and see the contrivance as it is certainly a very valuable improvement.—Letter from a Traveler, in the *American Railroad Journal*, January 16, 1836.

**CLEARING ICE FROM THE RAILS.**—Having several times been stormstayed on railroads and obliged at two different times to remain out all night in consequence of snow being

on the track, I take peculiar pleasure in witnessing the operation of any apparatus or contrivance for clearing snow or ice from the rails. Being at Newark on Monday last, I had the pleasure of witnessing the performance of a very simple contrivance of L. A. Sykes, the engineer of the New Jersey Railroad which far surpassed anything of the kind I ever before saw, both in regard to its simplicity and its effective operation. The apparatus consists simply of a pair of bars or levers attached to the front end of the engine and standing nearly in an upright position and operated upon by a rope or cord. It is used without the least possible danger even at the greatest speed and is so small that it can be conveniently carried at all times upon the engine or tender car and can be easily attached or detached at any time in one or two minutes. Railroad managers or superintendents will do well to call and see the contrivance as it is certainly a very valuable improvement.—Letter from a Traveler, in the *American Railroad Journal*, January 16, 1836.

**THOMAS M. EMERSON.**

Thomas Martin Emerson, president of the Atlantic Coast Line Railroad, died suddenly at his home in Wilmington, N. C., on the evening of November 25, following an attack of acute indigestion which occurred the day before while he was on a trip of inspection over the road with the directors of the company.

Mr. Emerson was the head of the traffic department of the Atlantic Coast Line for twenty-three years, and was one of the most prominent traffic men of the South. He was promoted to the presidency eight years ago.

Since Mr. Emerson has occupied the position of president of the Atlantic Coast Line, a broad policy of extension and improvement has been steadily carried out, bringing the road up to a very high standard. This work has included the construction of considerable double track and the relaying with heavier rails of the track on a very large portion of the system. A number of important stations have been replaced by more substantial modern structures, and a consistent policy of replacing wooden with steel trestles has been carried out. With the provision of better track and roadway facilities has come a corresponding increase in the weight and power of locomotives, bringing with it a corresponding increase in the train load.

One of the notable features of Mr. Emerson's regime has been the establishing of an agricultural and immigration department on the road. This department has been active in providing future traffic, both passenger and freight, by its work in inducing industries to establish along the line and also in bringing in settlers, both through its own direct action and through co-operation with private organizations and real estate companies. During the fiscal year 1907-1908, this resulted in the establishing on the Atlantic Coast Line of 154 industries and the bringing in of 667 settlers. In 1908 it was found necessary to divide the department into two branches in order to satisfactorily handle the increase in work over the system; and the results of the policy are seen in the fact that in the fiscal year 1910-1911 there were 3,521 heads of families settled along the lines of the road and 229 factories, mills, etc., located. Care has also been taken to educate, not only the new settlers, but the older settlers as well, in agricultural methods, and during 1911-1912 the road operated good roads trains, agricultural trains and farm demonstration trains for several months.

He was born in Preble county, Ohio, March 29, 1851, and began railway service in Indiana as a freight clerk at the age of 16. He worked on the Fort Wayne, Muncie & Cincinnati and the Charlotte, Columbia & Augusta (now a part of the Southern) and was a telegraph operator a part of the time. His first position on the Atlantic Coast Line was that of chief clerk in the general freight and passenger department in 1875. In 1881 he left and went to the Chesapeake & Ohio as assistant general freight agent, but he stayed only a year and then returned to the Atlantic Coast Line, and from August, 1882, to July, 1891, he was general freight and passenger agent of that road. He was then made traffic manager. In November, 1902, he became vice-president in charge of traffic, and three years later, November 21, 1905, was made president.

**CHANGSHA-CHUCHOU LINE, CHINA.**—The bridges on the Changsha-Chuchou line were completed during 1912, many of them having hitherto been merely temporary trestle bridges. Traffic was carried on without interruption, two trains having been running each way since January, 1912. So far but little freight traffic has been attracted, carriage on the adjacent waterway—the Siang river—being so much cheaper. A certain quantity of coal has, however, been carried from Pinghsiang to Changsha—not the coal of the Pinghsiang collieries, but of smaller mines worked by private companies. A further section from Chuchou to Lukou, about 10 miles in length, was commenced at the end of September, 1912, and towards the middle of December about nine-tenths of the earthworks and one-half of the bridge and culvert work was completed.

**RATE AT WHICH TIME OF TRAINS CAN BE MADE UP.**

BY PAUL M. LA-BACH,

Assistant Engineer, Chicago, Rock Island & Pacific, Chicago.

In riding on trains which are late we frequently hear discussions regarding making up time. The ordinary passenger, at least, thinks this can be very readily done if any one desires to do so. Whether time can be made up depends, of course, upon the schedule and the ability of the locomotive to make any increases in speed.

Just what happens when a train makes up a minute is shown in the accompanying table. The dividing lines indicate the speeds shown at their upper ends. The figures in the acute angles between these lines show the distance in miles the train must travel in order to make up one minute. Thus, if the train is running at an average speed of 35 miles an hour and increases it to 40 it will make up a minute in 4.6 miles. If it increases it from 35 to 45 miles an hour a minute will be made up in 2.6 miles. If the speed increases from 10 to 70 miles an hour, a minute will be made up in 0.17 miles.

A table of this kind may be used in making up tentative sched-

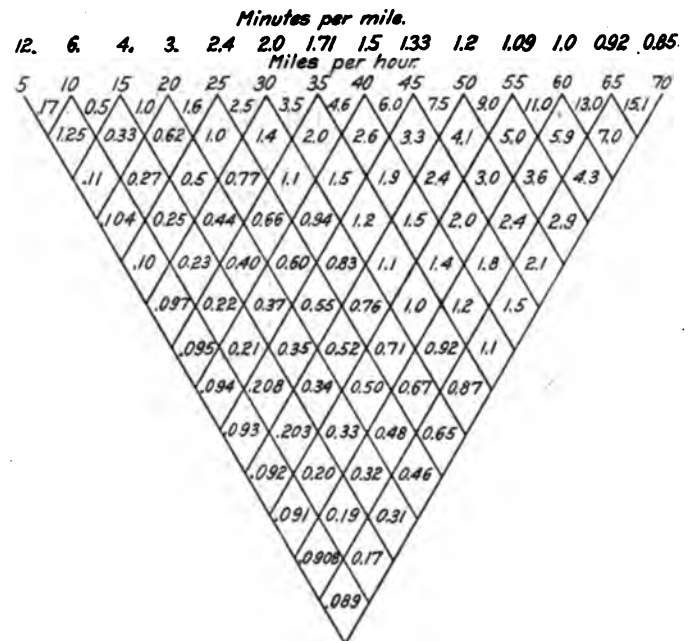

A Speed Diagram.

ules. For instance, if two points are 46 miles apart and the average speed is 35 m. p. h., what would be the saving in time by increasing the speed to 40 miles? Increasing speed 35 to 40 miles gives 4.6 miles as the distance required to save one minute. This divided into 46 miles gives 10 minutes.

The diagram may be used to find out the speed when the amount of time made up is known. A train with a scheduled speed between two points 50 miles apart of 40 miles an hour makes up 25 minutes. How fast did it go?  $50 \div 25 = 2$  miles in which it makes up one minute. Running down the 40 line we come to 2.0 at the intersection with the 60 m. p. h. line. The answer is that an average speed of 60 m. p. h. was made. It is apparent from a study of a table made up on this basis that a greater distance is required to make up a given amount of time than a layman would believe.

**STEAM CARRIAGE FOR BOSTON.**—We are gratified to learn that an effort is to be made to introduce a steam carriage for common roads between Cambridge and Boston, as well as between Salem and Boston.—From the American Railroad Journal, January 26, 1833.

## General News.

The Illinois State Board of Equalization has issued a report increasing the valuation of steam railway property by \$23,781,501, making the total in 1913, \$550,331,417.

The Trinity & Brazos Valley has agreed to make an increase in the pay of its telegraph operators averaging 6.7 per cent. The men had asked for an increase averaging 9.3 per cent.

A shipbuilding firm at Philadelphia has a contract to build a vessel 350 ft. long and 50 ft. beam, to be used as a car ferry between Key West, Fla., and Havana, a distance of about 80 miles.

The Wisconsin State Tax Commission has announced a preliminary statement of the assessment value of the railways of the state at \$348,028,000, an increase of \$21,775,000 over the final assessment of a year ago.

The Cincinnati, New Orleans & Texas Pacific has ordered the construction of a telephone line for train despatching from Oakdale, Tenn., south to Chattanooga, 84 miles; and on the completion of this line, telephones will be used for despatching throughout the whole length of the road, 335 miles.

The Klamath Lake Railroad has applied to the California State Railroad Commission for authority to abandon the operation of its road between Thrall, Cal., and Klamath Falls, Ore., 13 miles. The opening of a competing line from Weed to Klamath Falls has made the operation of this road unprofitable.

"The Brotherhood of Federated Railway Employees" is the name of a proposed organization which is being worked up among shop men and other employees of the Pennsylvania Railroad at Harrisburg, Altoona and elsewhere. The promoters of this enterprise invite railroad employees who are not eligible to membership in the older brotherhoods, to join the new one.

In the subways of New York City, operated by the Interborough Rapid Transit Company, 15 barrels of grease are used each month to lubricate rails on curves; this for the purpose not only of reducing the wear due to friction, but to prevent the disagreeable noises which otherwise would annoy passengers. The tracks on the curve at Times Square are greased five times every twenty-four hours.

L. B. Foley, superintendent of telegraph of the Delaware, Lackawanna & Western, has made a number of successful experiments with wireless telegraph from stations at Scranton, Pa., and Binghamton, N. Y., to a moving passenger train running between those cities, and from the train to the stations. Mr. Foley says that the sending of the current from the car to ground, through the rails of the track, worked successfully.

Two committees of the Chicago City Council, the committee on railway terminals and the committee on local transportation, have been in New York during the past week inspecting transportation lines in connection with plans for new terminals, electrification and subways in Chicago. They were accompanied by John F. Wallace and Bion J. Arnold, who have submitted reports advising the terminals committee on a proposed reorganization of the railway terminals of the city, and by a committee representing the railway employees who are opposing electrification.

The board of engineers appointed by the Moffat Tunnel Commission to report on the proposed tunnel through the Continental divide, near James Peak, to be built by the Denver & Salt Lake, has submitted a report that the tunnel can be built in four years at a cost of \$4,420,000. The engineers reported on three possible locations, recommending a site at an altitude of 9,100 feet, the tunnel to be 31,886 feet long, effecting a saving in elevation of 2,560 feet and in distance of 22.6 miles over the present route. The city of Denver is to furnish \$3,000,000 of the amount required in the form of a loan.

Seven officers of the Peterborough Railroad, of New Hampshire, have appealed to the Supreme Court of the United States against the decision of a lower court sustaining the Boston & Maine in refusing to grant them annual passes for interstate journeys. The Peterborough was leased to the Boston & Lowell and by the Boston & Lowell to the Boston & Maine; and these

officers claim that according to the lease they are entitled to annual passes over the Boston & Maine system. Since the first of the present year the B. & M. has refused to give passes except over its lines within the state of New Hampshire.

The United States Steel Corporation's profit-sharing records show that over 40,000 of its employees hold stock in the company. These holdings were acquired during eleven years of profit sharing. In that time subscriptions for 313,318 shares of preferred and 100,965 shares of common stock were received. The total amount of stock of both classes bought by the employees approximates \$38,500,000. The Youngstown Sheet & Tube Company of Youngstown, Ohio, announces that it will continue its profit-sharing plan for 1914. The company paid its employees about \$300,000 in September on the basis of net earnings of 6 per cent. It paid about \$250,000 in 1912.

### Is Berlin Only a Flag Station?

A press despatch from Prague, Austria, November 20 reports that Jules Vedrines, the French aviator, on that day flew from Nancy, France, across Germany, without descending, and landed near Prague at 2:20 p. m. The distance covered was about 400 miles.

### Another Kind of Accident.

In Cambridge, Mass., last week, Thomas P. Curtis, in a touring car, riding on Massachusetts avenue, very early in the morning, ran into a freight train; amount of claim not stated. Lack of lights at the crossing is the reason given by Mr. Curtis for the "accident." His car broke through one of the gates and struck a moving freight train, practically demolishing the machine and damaging the freight car to such an extent that it was necessary to cut it out of the train. Mr. Curtis, who was the only occupant of the automobile, escaped with a cut on his forehead.

### Texas Still Ahead.

In Texas it is judicially determined that if "Johnson grass" is allowed to go to seed upon a railroad right of way and the grass subsequently appears in a farmer's field adjoining, the owner of the field can obtain damages from the railroad, even if there be a public road between the right of way and the field. This is the substance of a decision handed down by the third court of civil appeals at Austin. A farmer obtained \$101 damages from the International & Great Northern Railroad for its negligence in not cutting the grass before the seed ripened. The claim of the railroad company that the existence of a road between the right of way and the field made the field "non-contiguous land," was not allowed by the court.

### Complete and Ideal Confidence.

In the last issue of the *Traffic Bulletin* of the Sunset Central Lines, which is in effect a monthly circular of instructions to agents, the editor shows how he would commend the road's dining cars, by printing the following paragraph:

"The dining car service on the Southern Pacific Lines is easily the best in the whole country and the management is constantly working to add to its already manifest attractiveness and superiority. The menus are varied, food is of the highest quality and service practically perfect. It is one of the best cards we have to solicit and retain patronage and the general public is quick to realize the fact that they can get more for their money than is offered or supplied by the best restaurants or hostleries of the larger cities in the United States. We believe that our patrons are entitled to the best the market affords and this they are getting. The dining cars are up-to-date in every detail and the careful inspection which both equipment and service are daily securing insures a continuation of their present high reputation."

### The Illinois Anti-Pass Law.

The Chicago & Alton and the Illinois Central have announced that after January 1 they will issue no passes in Illinois except to railway employees. No official ruling has yet been made, but it is understood that all of the principal roads of Illinois have decided that the anti-discrimination clause in the new public utilities law, which goes into effect January 1, makes passes il-

legal except for employees; and accordingly will take the same action that has been taken by the Alton and the Illinois Central.

#### Who Was This Ohio Man?

Care should be given to details in answering complaints. A short time ago I received a complaint from a man who lives in Ohio. He said the coffee served on the Pennsylvania Lines' dining cars was not good. I suspected that something might have been wrong and so I sent him a sample of the coffee served on our trains, the best that money can buy; and I told him to try it at his home. He did and said it was all right. The trouble was that when he was served the drink on our train he had gotten up late and so the coffee had been standing too long; and therefore it did not suit him. He wrote me a letter saying he had not believed that a passenger agent would take up such trivial matters. We must get down to details if we are to make the Pennsylvania Lines a great success.—*Samuel Moody, P. T. M.*, speaking to traveling agents.

#### Appealing to Trespassers' Direct.

On the Baltimore & Ohio a trackwalker patrolling the road, or a section foreman or one of his workmen when meeting a person tramping along the tracks, whether it be a confirmed hobo or a respectable citizen like a mill employee, he points out to him the danger which lurks in this careless practice. The appeal is backed up by information as to the number of lives that are sacrificed and the permanent injuries that occur each year as a result of people using the railroad as a public highway. The maintenance of way department has a representative on the safety committees of the company, and through these officers the men at work on the tracks are made acquainted with accident statistics. Already there has been an appreciable reduction in the number of deaths and serious injuries. The Claims Department of the road attributes this in large measure to the efforts of the track forces in calling attention to the dangerous practice. Recently a trackwalker was passing a factory adjacent to the right of way just as the factory operatives were coming out. Four young women started up the tracks towards their homes, walking on one of the main tracks. The trackwalker impressed upon the women the danger they were assuming, fortifying his statement by telling them that Miss Pearl Williamson, having assumed the same risk, had lost her life, Miss Williamson having been the twelfth person killed in the same manner on that division during the past year. Presenting the matter with due force he convinced his audience, and now the employees have discontinued using the tracks as a highway.

#### Brakemen and College Professors.

A young man may enter the service of a railroad as a brakeman and get as much pay as does the young graduate of a school of engineering, and may look forward to earning as much in the road's service as does a full professor in many a college. This is not a result of the award made by the arbitration board; it was true before that. With that condition existing the trainmen were yet granted an increase. It is an interesting fact that a young man who has had no preliminary training may become a railroad brakeman and get \$85 a month, and that this same man, who begins as a brakeman, may look forward to making over \$1,900 a year as a conductor. The Baltimore & Ohio has conductors who average \$240 a month, which is as much as a professor in college makes. The dean of a certain engineering school makes only \$2,000 a year. There are in the Baltimore & Ohio service 68 trainmen who now make (without this last increase) \$1,935 a year, and 1,474 trainmen who make \$1,273 a year. The Pennsylvania has 1,146 men who make \$1,962 and a proportionate number who make above \$1,200. Other roads have the same proportion of men making such salaries. Some of the conductors who make these higher salaries work usually four hours a day, and about 18 days out of 30.—*A. W. Thompson, General Manager, B. & O.*

#### Government Ownership the Alternative.

This country has the best transportation system, at the lowest rates, and operated by the highest paid employees, of any system in the world. It would still have this if a slight increase was made in the rates of transportation.

The railway stockholders of this country are made up of hundreds of thousands of all classes of our citizens. On the Pennsylvania railroad more than one-half of the stockholders are women, but I am making no plea for the stockholders—they can probably take care of themselves, and it is because I fear that they will take care of themselves and leave the railways to shift for themselves that I am disturbed regarding the railway situation.

If private capital continues to withhold from railway investments, as it is now doing, government ownership will be the only alternative, and while this will probably be the ultimate solution of the problem, I do not believe the country is ready for it yet. Pending the time when the people are ready for that, the splendid railway system which they now have should be kept intact and improved in accordance with the necessities of commerce, in order that when it is taken over by the government, it will not have deteriorated so that the government will have to tax the people for its rehabilitation.

It may also be set down as a certainty that if there is no change in the conditions when the government does take over the railways, one of three things must happen—either the rates will be raised, wages reduced or the deficit will have to be made up by taxation.

Fortunately our people have the experience of other countries to guide them. There is practically no government owned and operated railway in the world that has not increased its freight or passenger rates during the past five years and there is, I believe, more dissatisfaction among the shippers on government railways than on private railways in the same countries, or, for that matter, in any country.—*From an address by H. U. Mudge, president Chicago, Rock Island & Pacific, before the Kansas City Commercial Club, November 19.*

#### State Regulations for Interlocking Signals in Illinois and Wisconsin.

The rules governing the construction, maintenance and operation of interlocking plants, which were formulated recently by a committee of engineers representing the railroad commissions of Illinois, Wisconsin, Minnesota, and Indiana, have been adopted by the Illinois Commission to become effective December 1. These rules will also go into effect in Wisconsin on the same day, having been adopted by the commission of that state on October 8.

This code of rules was printed in full in *The Signal Engineer* for August, page 257. Since then some slight changes have been made and these changes are set forth in *The Signal Engineer* for November, page 354.

#### The Melun Collision.

The collision at Melun, France, on the Paris, Lyons & Mediterranean, on November 4, briefly reported in our issue of November 7, page 879, was due to over-running of signals. A southbound train consisting wholly of mail cars, was crossing the northbound track, to enter a loop line, and was struck by a northbound express passenger train, which had passed two distant signals at about 50 miles an hour. The collision occurred at about 9:20 p. m. The only explanation that has thus far been given out is that the engineman of the passenger train admits that he passed the signals without seeing them. The first distant signal encountered by him was 3,773 ft. in the rear of the fouling point, where the collision occurred; and the other, called a "warning" signal, was 3,182 ft. back. The home signal was 502 ft. in the rear of the crossing or junction. The distant signal is visible to the engineman for a distance of 1,000 ft. or more before the train reaches it.

The railroad company had already decided, before the occurrence of this collision, to equip the whole of its line between Paris and Dijon, about 150 miles, with audible cab signals. Some of the roadside apparatus for cab signal operation had already been installed.

English critics are calling attention to the fact that, in a situation like this, it would be necessary, under the block signal rules prescribed by the British Railway Clearing House, to have kept the switches set so as to divert the mail train to another track until the northbound passenger train had been brought to a stop; or, what is equivalent to the same thing, the passenger



train would not have been allowed to pass the last block station in the rear while the crossing was set for the mail train.

#### Investigation of the Frisco Receivership.

The investigation by the Interstate Commerce Commission of the causes which led to the receivership of the St. Louis & San Francisco was begun at St. Louis on November 18 before Chairman E. E. Clark and continued for three days. B. F. Yoakum, chairman of the executive committee of the road, was the principal witness and was questioned in detail by D. E. Brown, examiner for the commission, regarding the transactions by which subsidiary roads promoted by syndicates were sold to the parent company. Mr. Brown said the records showed large profits made by the promoters. Mr. Yoakum said he was unable to give details and referred to the records of the St. Louis Union Trust Company. He ascribed the receivership to the failure to sell Arizona and New Mexico lands, losses on Texas and Louisiana lumber properties and losses incurred through the ownership of the Chicago & Eastern Illinois. He outlined his plan for a "water level" railway route from St. Louis to the Panama canal, which he said had failed because of the Mexican revolution.

Mr. Brown presented data to show that in the ten years prior to the receivership the Frisco had sold securities for \$32,000,000 less than their par value.

A. T. Perkins, vice-president of the St. Louis, Brownsville & Mexico, testified that the syndicate of 99 persons who sold the Brownsville road to the Frisco made a profit of \$3,000,000 or about 75 per cent. on their investment. The St. Louis Union Trust Company also made public the names of the syndicate members, which included many officers and directors of the Frisco, and other records from which it was calculated that Yoakum and his associates had made a profit of over \$7,000,000 in the sale of properties to the Frisco.

C. W. Hillard, vice-president of the Frisco, was questioned regarding the affairs of the Gulf Construction Company, which figured in several of the syndicate transactions.

#### American Society of Mechanical Engineers.

In connection with the annual meeting of the American Society of Mechanical Engineers, which is to be held in New York, December 2-5, there will be a railway session on Wednesday, December 3, at 2 p. m.

Two papers will be presented, one on Steel Frame Box Cars, by R. W. Burnett, general master car builder of the Canadian Pacific, and one on Steel Underframe Box Cars, by G. W. Rink, mechanical engineer of the Central of New Jersey.

Mr. Burnett, in his paper on Steel Frame Box Cars, considers the development of this type of car and outlines some of the factors which have been responsible for it. The practice on the Canadian Pacific, particularly in reference to the repairs, and the advantages of this type of car, are considered and special attention is directed to the methods of selecting and treating the lumber for the sheathing and lining.

Mr. Rink presents several tables showing the practice of a number of roads regarding the dimensions of various parts of box cars. These tables were prepared with a view to making it possible to select a design which would embody the best practice. Mr. Rink believes that further steps should be taken toward adopting standards for use on the box cars of the railroads generally and suggests that a committee representing the different roads should be appointed with a view to developing a standard box car.

The excursion committee of the society has made special arrangements with the Davis-Bournonville Company, Jersey City, N. J., to give a comprehensive and practical exhibition of the recent development in the oxy-acetylene and oxy-hydric processes of welding and cutting metals. This exhibition will take place on December 4. It is planned to show the commercial method of producing oxygen, acetylene and hydrogen gases and the welding of cast iron, steel, brass, and aluminum by hand. There will also be other demonstrations.

#### New York Railroad Club.

The meeting of the New York Railroad Club on Friday, November 21, was of an unusual type. Daniel M. Brady presented

a paper on "The Past, Present and Future of Railway Clubs." It was largely of a historical nature and covered the progress of the club from its very beginning. Several of the other railway clubs were officially represented at the meeting—the St. Louis Club by W. G. Besler, who was one of its charter members and was very actively identified with it for a number of years; the Railway Club of Pittsburgh by J. B. Anderson, its secretary; the Canadian Railway Club by James Powell, its secretary. In addition F. W. Brazier commented on the educational value of railway clubs, and F. M. Whyte made a suggestion looking toward a more effective preparation and presentation of the subjects at the monthly meetings. The following officers were elected for the ensuing year: President, G. W. Wildin, mechanical superintendent of the New York, New Haven & Hartford; first vice-president, C. W. Huntington; second vice-president, Frederick C. Syze; third vice-president, Burton P. Flory, and treasurer, R. M. Dixon.

#### American Railway Association.

In accordance with a vote taken at the regular meeting in Chicago, November 19, an adjourned meeting of the association will be held at The Blackstone, Chicago, on Wednesday, December 3, at 10 a. m. The consideration of the report of the Committee on Relations between Railroads, which was not completed at the regular session, is to be made the special order of business. That portion of the report relative to the recommendations of the Subcommittee on Weighing and the Subcommittee on Packing, Marking and Handling of Freight was acted on at the regular meeting.

#### MEETINGS AND CONVENTIONS.

*The following list gives names of secretaries, dates of next or regular meetings, and places of meeting.*

- AIR BRAKE ASSOCIATION.—F. M. Nellis, 53 State St., Boston, Mass. Next convention, May, 1914.
- AMERICAN ASSOCIATION OF DEMURRAGE OFFICERS.—A. G. Thomason, Boston, Mass. Convention, May 19, 1914, St. Louis.
- AMERICAN ASSOCIATION OF GENERAL PASSENGER AND TICKET AGENTS.—W. C. Hope, New York.
- AMERICAN ASSOCIATION OF FREIGHT AGENTS.—R. O. Wells, East St. Louis, Ill. Next convention, April 21, Houston, Tex.
- AMERICAN ASSOCIATION OF RAILROAD SUPERINTENDENTS.—E. H. Harman, St. Louis, Mo.; 3d Thursday and Friday in May.
- AMERICAN ELECTRIC RAILWAY ASSOCIATION.—H. C. Donecker, 29 W. 39th St., New York.
- AMERICAN ELECTRIC RAILWAY MANUFACTURERS' ASSOC.—H. G. McConaughy, 165 Broadway, New York. Meetings with Am. Elec. Ry. Assoc.
- AMERICAN RAILWAY ASSOCIATION.—W. F. Allen, 75 Church St., New York.
- AMERICAN RAILWAY BRIDGE AND BUILDING ASSOCIATION.—C. A. Lichy, C. & N. W., Chicago. Next convention, October 20-22, 1914, Los Angeles, Cal.
- AMERICAN RAILWAY ENGINEERING ASSOCIATION.—E. H. Fritch, 900 S. Michigan Ave., Chicago. Next convention, March 17-20, Chicago.
- AMERICAN RAILWAY MASTER MECHANICS' ASSOCIATION.—J. W. Taylor, Karpen building, Chicago. June 15-17, Atlantic City, N. J.
- AMERICAN RAILWAY TOOL FOREMEN'S ASSOCIATION.—A. R. Davis, Central of Georgia, Macon, Ga.
- AMERICAN SOCIETY FOR TESTING MATERIALS.—Prof. E. Marburg, University of Pennsylvania, Philadelphia, Pa.
- AMERICAN SOCIETY OF CIVIL ENGINEERS.—C. W. Hunt, 220 West 57th St., New York; 1st and 3d Wed., except June and August, New York.
- AMERICAN SOCIETY OF ENGINEERING CONTRACTORS.—J. R. Wenlinger, 11 Broadway, New York; 2d Tuesday of each month, New York.
- AMERICAN SOCIETY OF MECHANICAL ENGINEERS.—Calvin W. Rice, 29 W. 39th St., New York.
- AMERICAN WOOD PRESERVERS' ASSOCIATION.—F. J. Angier, B. & O., Baltimore, Md. Next convention, January 20-22, 1914, New Orleans, La.
- ASSOCIATION OF AMERICAN RAILWAY ACCOUNTING OFFICERS.—C. G. Phillips, Highland Park, Ill. Annual meeting, June 24, Minneapolis, Minn.
- ASSOCIATION OF RAILWAY CLAIM AGENTS.—C. W. Egan, B. & O., Baltimore, Md. Next convention, May, 1914, St. Paul, Minn.
- ASSOCIATION OF RAILWAY ELECTRICAL ENGINEERS.—Jos. A. Andreucetti, C. & N. W. Ry., Chicago.
- ASSOCIATION OF RAILWAY TELEGRAPH SUPERINTENDENTS.—P. W. Drew, 112 West Adams St., Chicago. Next convention, May 20-23, New Orleans, La.
- ASSOCIATION OF TRANSPORTATION AND CAR ACCOUNTING OFFICERS.—G. P. Conrad, 75 Church St., New York. Next meeting, December 9-10, Galveston, Tex.
- ASSOCIATION OF WATER LINE ACCOUNTING OFFICERS.—W. R. Evans, Chamber of Commerce, Buffalo, N. Y.
- BRIDGE AND BUILDING SUPPLY MEN'S ASSOCIATION.—L. D. Mitchell, Detroit Graphite Co., Detroit, Mich. Meeting with American Railway Bridge and Building Association.
- CANADIAN RAILWAY CLUB.—James Powell, Grand Trunk Ry., Montreal, Que.; 2d Tuesday in month, except June, July and Aug., Montreal.
- CANADIAN SOCIETY OF CIVIL ENGINEERS.—Clement H. McLeod, 413 Dorchester St., Montreal, Que.; Thursday, Montreal.

## Traffic News.

The Lehigh Valley has put in service in New York harbor two refrigerating barges, each ninety feet long, and three more are to follow. These are used in transferring fruit and other perishable freight to steamers. The interiors of the barges have a uniform temperature of 40 deg. F.

On the Pennsylvania Railroad passengers buying round trip excursion tickets and using only the going portion, may have the return portion redeemed (with the usual deduction) at the office where the ticket was bought. Heretofore the claim had to be sent to the general passenger agent.

James J. Hill is reported to have announced that two passenger steamships will be put in service on January 1, 1915, between San Francisco, Cal., and Astoria, Ore., connecting at Astoria with express trains to Portland, on a schedule of 24 or 25 hours, through. The boats will cost about \$2,500,000 each. They are intended to secure some of the traffic to and from the Panama-Pacific Exposition.

The freight traffic of St. Louis made a new record during the fiscal year ended June 30. The Terminal Railroad Association report the number of loaded freight cars interchanged by railroads in the 12 months as 2,213,301; increase over preceding year 245,054 cars, or 12.45 per cent. This total of about 184,000 cars a month does not include all the freight cars handled in St. Louis, or even all interchanged. Thousands of cars were moved direct to and from industries situated on the tracks of individual lines, and thousands are interchanged directly between individual roads whose tracks connect. The total is valuable as an index of commercial activity.

The State Colleges of Agriculture of Maryland and Delaware, and the Pennsylvania Railroad Company will, on December 8, start on an extensive program of carrying the gospel of intensive farming to the homes of farmers living on the eastern shores of Maryland and Virginia, and throughout the State of Delaware, the lecturers traveling on a special train provided free by the railroad company. These agricultural missionaries will tour the entire Peninsula, stopping at 31 stations. Six days will be required to make the tour. The principal subjects to be treated are: Soil fertility, peaches, apples, berries, melons, celery, asparagus, potatoes, tomatoes, alfalfa, dairying, live stock, hog cholera and poultry.

The governor of North Carolina has appointed the Special Commission, provided for in the recent law fixing rates for the transportation of freight, the commission to have power to modify the rates laid down in the statute if unreasonableness be found. The commission consists of W. L. Poteat, of Wake Forest; Judge M. H. Justice, of Rutherfordton, and A. A. Thompson, of Raleigh. Dr. Poteat is president of Wake Forest College; Judge Justice is a prominent judge of the Supreme Court, and Mr. Thompson is a prominent cotton mill man of Raleigh and treasurer of the North Carolina Just Freight Rate Association. The appointment of the commission will postpone for several months the enforcement of the new law.

The New York Board of Trade and Transportation, after discussing the increase of 5 per cent. in freight rates, which the railroads proposed to make throughout the eastern and central states, took no positive action; but the discussion was in general favorable to the application of the railroads. The board authorized a committee to appear at the hearings in Washington.

Thomas C. Spelling of New York, representing the "Freight Payers' League of the United States," presented to the Interstate Commerce Commission at Washington this week, a protest against the employment by the commission of Louis D. Brandeis, of Boston. It is claimed that he has no standing at the hearing except as an individual. Mr. Spelling declared that there was no authority in law for the appointment by the commission of an attorney to represent "the public."

The Chicago Association of Commerce last week addressed to the Interstate Commerce Commission resolutions adopted by the freight traffic committee, expressing the association's position in regard to the proposed advance in freight rates. The resolutions state that the committee is in sympathy with the plan of having the question adjudicated by the Interstate Commerce

- CAR FOREMEN'S ASSOCIATION OF CHICAGO.—Aaron Kline, 841 North 50th Court, Chicago; 2d Monday in month, Chicago.
- CENTRAL RAILWAY CLUB.—H. D. Vought, 95 Liberty St., New York; 2d Thurs. in Jan. and 2d Fri. in March, May, Sept., Nov., Buffalo, N. Y.
- CIVIL ENGINEERS' SOCIETY OF ST. PAUL.—L. S. Pomeroy, Old State Capitol building, St. Paul, Minn.; 2d Monday, except June, July, August and September, St. Paul.
- ENGINEERS' SOCIETY OF PENNSYLVANIA.—E. R. Dasher, Box 704, Harrisburg, Pa.; 1st Monday after second Saturday, Harrisburg, Pa.
- ENGINEERS' SOCIETY OF WESTERN PENNSYLVANIA.—E. K. Hiles, Oliver building, Pittsburgh; 1st and 3d Tuesday, Pittsburgh, Pa.
- FREIGHT CLAIM ASSOCIATION.—Warren P. Taylor, Richmond, Va. Next convention, May 20-22, Galveston, Tex.
- GENERAL SUPERINTENDENTS' ASSOCIATION OF CHICAGO.—E. S. Koller, 226 W. Adams St., Chicago; Wed. preceding 3d Thurs., Chicago.
- INTERNATIONAL RAILWAY CONGRESS.—Executive Committee, 11, rue de Louvain, Brussels, Belgium. Convention, 1915, Berlin.
- INTERNATIONAL RAILWAY FUEL ASSOCIATION.—C. G. Hall, 922 McCormick building, Chicago. Annual convention, May 18-22, Chicago.
- INTERNATIONAL RAILWAY GENERAL FOREMEN'S ASSOCIATION.—Wm. Hall, 829 West Broadway, Winona, Minn. Next convention, July, Chicago.
- INTERNATIONAL RAILROAD MASTER BLACKSMITHS' ASSOCIATION.—A. L. Woodworth, Lima, Ohio. Next convention, third Tuesday in August.
- MAINTENANCE OF WAY & MASTER PAINTERS' ASSOCIATION OF THE UNITED STATES AND CANADA.—W. G. Wilson, Lehigh Valley, Easton, Pa.
- MASTER BOILER MAKERS' ASSOCIATION.—Harry D. Vought, 95 Liberty St., New York.
- MASTER CAR BUILDERS' ASSOCIATION.—J. W. Taylor, Karpen building, Chicago. June 10-12, Atlantic City, N. J.
- MASTER CAR & LOCOMOTIVE PAINTERS' ASSOC. OF U. S. AND CANADA.—A. P. Dane, B. & M., Reading, Mass.
- NATIONAL RAILWAY AFFLIANCE ASSOC.—Bruce V. Crandall, 537 So. Dearborn St., Chicago. Meetings with Am. Ry. Eng. Assoc.
- NEW ENGLAND RAILROAD CLUB.—W. E. Cade, Jr., 683 Atlantic Ave., Boston, Mass.; 2d Tuesday in month, except June, July, Aug. and Sept., Boston.
- NEW YORK RAILROAD CLUB.—H. D. Vought, 95 Liberty St., New York; 3rd Friday in month, except June, July and August, New York.
- NORTHERN RAILROAD CLUB.—C. L. Kennedy, C. M. & St. P., Duluth, Minn.; 4th Saturday, Duluth.
- PEORIA ASSOCIATION OF RAILROAD OFFICERS.—M. W. Rotchford, Union Station, Peoria; 2d Thursday.
- RAILROAD CLUB OF KANSAS CITY.—C. Manlove, 1008 Walnut St., Kansas City, Mo.; 3d Friday in month, Kansas City.
- RAILWAY BUSINESS ASSOCIATION.—Frank W. Noxon, 2 Rector St., New York. Annual dinner, December 11, 1913, New York.
- RAILWAY CLUB OF PITTSBURGH.—J. B. Anderson, Penna. R. R., Pittsburgh, Pa.; 4th Friday in month, except June, July and August, Pittsburgh.
- RAILWAY ELECTRICAL SUPPLY MANUFACTURERS' ASSOC.—J. Scribner, 1021 Monadnock Block, Chicago. Meetings with Assoc. Ry. Elec. Engrs.
- RAILWAY FIRE PROTECTION ASSOCIATION.—C. B. Edwards, Mobile & Ohio, Mobile, Ala.
- RAILWAY GARDENING ASSOCIATION.—J. S. Butterfield, Lee's Summit, Mo.
- RAILWAY DEVELOPMENT ASSOCIATION.—W. Nicholson, Kansas City Southern, Kansas City, Mo.
- RAILWAY SIGNAL ASSOCIATION.—C. C. Rosenberg, Bethlehem, Pa.
- RAILWAY STOREKEEPERS' ASSOCIATION.—J. P. Murphy, Box C, Collinwood, Ohio.
- RAILWAY SUPPLY MANUFACTURERS' ASSOC.—J. D. Conway, 2135 Oliver bldg., Pittsburgh, Pa. Meetings with M. M. and M. C. B. Assocs.
- RAILWAY TEL. & TEL. AFFLIANCE ASSOC.—W. E. Harkness, 284 Pearl St., New York. Meetings with Assoc. of Ry. Teleg. Sups.
- RICHMOND RAILROAD CLUB.—F. O. Robinson, Richmond, Va.; 2d Monday except June, July and August.
- ROADMASTERS' AND MAINTENANCE OF WAY ASSOCIATION.—L. C. Ryan, C. & N. W., Sterling, Ill.
- ST. LOUIS RAILWAY CLUB.—B. W. Frauenthal, Union Station, St. Louis, Mo.; 2d Friday in month, except June, July and Aug., St. Louis.
- SIGNAL AFFLIANCE ASSOCIATION.—F. W. Edmonds, 3868 Park Ave., New York. Meeting with annual convention Railway Signal Association.
- SOCIETY OF RAILWAY FINANCIAL OFFICERS.—C. Nyquist, La Salle St. Station, Chicago.
- SOUTHERN ASSOCIATION OF CAR SERVICE OFFICERS.—E. W. Sandwich, A. & W. P. Ry., Montgomery, Ala.
- SOUTHERN & SOUTHWESTERN RAILWAY CLUB.—A. J. Merrill, Grant bldg., Atlanta, Ga.; 3d Thurs., Jan., March, May, July, Sept., Nov., Atlanta.
- TOLEDO TRANSPORTATION CLUB.—J. G. Macomber, Woolson Spice Co., Toledo, Ohio; 1st Saturday, Toledo.
- TRACK SUPPLY ASSOCIATION.—W. C. Kidd, Ramapo Iron Works, Hillaburn, N. Y. Meetings with Roadmasters' and Maintenance of Way Association.
- TRAFFIC CLUB OF CHICAGO.—W. H. Wharton, La Salle Hotel, Chicago.
- TRAFFIC CLUB OF NEW YORK.—C. A. Swope, 290 Broadway, New York; last Tuesday in month, except June, July and August, New York.
- TRAFFIC CLUB OF PITTSBURGH.—D. L. Wells, Erie, Pittsburgh, Pa.; meetings monthly, Pittsburgh.
- TRAFFIC CLUB OF ST. LOUIS.—A. F. Versen, Mercantile Library building, St. Louis, Mo. Annual meeting in November. Noonday meetings October to May.
- TRAIN DISPATCHERS' ASSOCIATION OF AMERICA.—J. F. Mackie, 7122 Stewart Ave., Chicago. Next convention, June 16, Jacksonville, Fla.
- TRANSPORTATION CLUB OF BUFFALO.—J. M. Sells, Buffalo; first Saturday after first Wednesday.
- TRANSPORTATION CLUB OF DETROIT.—W. R. Hurley, L. S. & M. S., Detroit, Mich.; meetings monthly.
- TRAVELING ENGINEERS' ASSOCIATION.—W. O. Thompson, N. Y. C. & H. R., East Buffalo, N. Y. Next meeting, Chicago.
- UTAH SOCIETY OF ENGINEERS.—Fred D. Ulmer, Oregon Short Line, Salt Lake City, Utah; 3rd Friday of each month, except July and August.
- WESTERN CANADA RAILWAY CLUB.—W. H. Rosevear, P. O. Box 1707, Winnipeg, Man.; 2d Monday, except June, July and August, Winnipeg.
- WESTERN RAILWAY CLUB.—J. W. Taylor, Karpen building, Chicago; 3d Tuesday of each month, except June, July and August.
- WESTERN SOCIETY OF ENGINEERS.—J. H. Warder, 1735 Monadnock Block, Chicago; 1st Monday in month, except July and August, Chicago.

Commission, but that it looks upon the proposed advance as experimental. If the benefits arising therefrom are mutual and of a permanent nature, the increase may be justified. If, on the contrary, the results are not permanent and a request for another increase in rates follows, it will demonstrate that advances in rates do not meet the issues involved, nor provide a remedy for existing conditions. The committee, however, is irrevocably opposed to another advance in the present rail and lake rates between the Atlantic Seaboard and the West, on the ground that these rates have been advanced three times since 1900, a total of approximately 11 per cent., without any change in the all-rail rates.

It is reported that certain cities in Virginia object to the bargain which the railroads have made with the state of North Carolina to reduce freight rates from the west to points in N. C., on the ground that unless similar reductions are made to the Virginia points there will be discrimination. It is expected that the objectors will present their case at Washington. Governor Craig and the Corporation Commission of North Carolina propose to press the case as speedily as possible. A number of the state officers at Raleigh are expressing indignation as to the action of the Virginia cities in thus attempting to choke off this freight rate advantage from Carolina merchants in view of the much more reduced rates these cities have enjoyed for many years. Some are suggesting that it is up to the North Carolina Just Freight Rate Association and other commercial bodies interested, to start a boycott of the Virginia cities.

**Each For Himself.**

The American Association of General Passenger and Ticket Agents at its recent meeting decided to abandon the "See America First" movement as a subject for collective action. The following resolution was adopted:

"Searching and careful consideration of this question discloses the fact that it is one which cannot well be handled by collective action. Its ramifications are so extensive and varied that its handling as a unit would be most difficult. The committee concludes that it is essentially a question from which benefit can best be derived through individual effort. The agitation during the past two years has resulted in the adoption of the slogan 'See America First,' 'See America Now,' 'See America,' etc., by several of the carriers, and has created quite a wide-spread discussion editorially and otherwise by the press of the country. To that extent, it has inured to the benefit of the carriers, but in view of the experience of your committee in its negotiations with those interested, it is believed that further attempts to induce collective effort on the part of the carriers of the country would be futile and, it is, therefore, suggested that your committee be discharged."

**Car Location.**

The accompanying table, which was taken from bulletin No. 11-A of the American Railway Association, gives a summary of freight car location by groups on October 15, 1913.

	CAR LOCATION ON OCTOBER 15, 1913.												
	New England.	N.Y., Del., Md., Pa.	N.J., Mich., W. Va., Pa.	Ohio, Ind., Mich., W. Va., Pa., Carolina.	Ill., Ala., Ga., Fla.	Ohio, Tenn., Miss., Ala., Ga., Fla.	Iowa, Wyo., Minn.	Mont., Neb., Dakotas.	Kans., Colo., Mo., Ark.	Texas, La., New Mexico.	Oregon, Idaho, Nev., Cal., Ariz.	Canadian Lines.	Grand Total.
Total Cars Owned.....	88,175	685,523	278,962	204,499	172,783	486,772	18,881	154,552	30,641	133,736	142,317	2,396,841	
Home Cars on Home Roads.....	40,410	368,872	95,609	105,244	83,750	326,257	7,209	79,685	13,873	73,973	92,985	1,287,867	
Home Cars on Foreign Roads.....	47,765	316,651	183,353	99,255	89,033	160,515	11,672	74,867	16,768	59,763	49,332	1,108,974	
Foreign Cars on Home Roads.....	56,923	307,945	206,327	84,072	79,248	196,818	10,858	77,177	29,025	57,649	40,896	1,146,938	
Total Cars on Line.....	97,333	676,817	301,936	189,316	162,998	523,075	18,067	156,862	42,898	131,622	133,881	2,434,805	
Excess or Deficiency.....	9,158	*8,706	22,974	*15,183	*9,785	36,303	*814	2,310	12,257	*2,114	*8,436	37,964	
Surplus.....	311	1,659	533	5,093	1,091	5,746	1,110	4,017	5,172	12,428	1,116	38,276	
Shortage.....	663	3,838	8,058	8,304	1,643	2,965	128	1,254	231	2,177	10,857	40,118	
Shop Cars—													
Home Cars in Home Shops.....	5,767	33,986	22,268	13,070	13,732	26,839	540	11,313	2,264	4,181	6,273	140,233	
Foreign Cars in Home Shops.....	1,150	8,877	7,677	1,788	2,124	5,563	431	2,618	961	2,105	402	33,696	
Total Cars in Shops.....	6,917	42,863	29,945	14,858	15,856	32,402	971	13,931	3,225	6,286	6,675	173,929	
Per Cent. to Total Cars Owned—													
Home Cars on Home Roads.....	45.83	53.81	34.27	51.46	48.47	67.02	38.18	51.56	45.28	55.31	65.34	53.73	
Total Cars on Line.....	107.61	98.73	108.14	92.58	94.34	107.46	95.70	100.09	140.03	98.42	94.07	101.58	
Home Cars in Home Shops.....	6.54	4.96	7.98	6.39	7.95	5.55	2.86	7.32	7.39	3.13	4.41	5.85	
Foreign Cars in Home Shops.....	.91	1.29	2.75	.88	1.23	1.15	2.28	1.58	3.14	1.57	.28	1.41	
Total Cars in Shops.....	7.45	6.25	10.73	7.27	9.18	6.70	5.14	8.90	10.53	4.70	4.69	7.26	

\*Denotes deficiency.

**Grievances Graphically Described.**

The team-owners of New York City, following the example set by those of Philadelphia, have complained to the Interstate Commerce Commission of poor facilities at New York freight houses. The Team Owners' Association has 65 members, who have 1,500 horses and auto trucks hauling freight. It is alleged that merchandise is placed both in railroad and in steamship freight houses in a heterogeneous mass, piled frequently without longitudinal or transverse aisles, and where there are aisles they are barely large enough for the passage of a truck.

The charge is made that fragile articles like those of glass, are mingled with iron pipe, and oil with carpets, rags, wool, cotton and other inflammable materials; that beer in barrels is piled with furniture and machinery, and that the goods of one merchant are superimposed on the goods of another; while boxes, bales, and bundles are dumped together when unloaded from freight cars without regard to whether the markings on the goods are visible, parts of consignments arriving together being frequently separated by careless handling and so promiscuously scattered as to be reported "lost."

It is averred that at the end of three days such reported "lost" goods are put in storage houses owned by the railroads or steamship companies and that consignees are compelled to pay the unloading and storage charges. It is asserted that drivers frequently are compelled to go into the cars on the tracks to obtain goods to be delivered by team.

The association alleges that the carriers show favoritism to certain team owners, allowing them to drive past teams having prior position in line. It is alleged that the carriers do not employ enough clerks, weighers and checkers.

**Summary of Revenues and Expenses of Steam Roads in September.**

The Bureau of Railway Economics' summary of revenues and expenses and comments thereon for September, 1913, are as follows: The railways whose returns are included in this summary operate 224,438 miles of line, or about 90 per cent. of the steam railway mileage in the United States. The operating revenues for the month of September, 1913, amounted to \$277,558,806. Compared with September, 1912, the total operating revenues show an increase of \$9,143,738. These total operating revenues per mile of line averaged \$1,237 in September, 1913, and \$1,206 in September, 1912, an increase of \$31, or 2.6 per cent. Freight revenue per mile increased 2.4 per cent., and passenger revenue per mile 2.6 per cent.

Operating expenses amounted to \$186,711,085. This was \$14,139,569 more than for September, 1912. These operating expenses per mile of line averaged \$832 in September, 1913, and \$775 in September, 1912, an increase of \$57 per mile, or 7.3 per cent.

Net operating revenue amounted to \$90,847,721. This was \$4,995,831 less than for September, 1912. Net operating revenue per mile of line averaged \$405 in September, 1913.

and \$431 in September, 1912, a decrease of \$26 per mile, or 6.0 per cent.

Taxes for the month of September amounted to \$11,017,987, or \$49 per mile, an increase of 6.6 per cent. over September, 1912.

Operating income averaged \$356.15 per mile of line, and in September, 1912, \$387.54, thus decreasing \$31.39, or 8.1 per cent. Operating income for each mile of line for each day in September averaged \$11.87 and for September, 1912, \$12.92.

The operating ratio for September was 67.3 per cent., which is comparable with 68.2 per cent. in August, 1913, and 64.3 per cent. in September, 1912.

The railways of the eastern district show an increase in total operating revenues per mile of line as compared with September, 1912, of 3.3 per cent., the railways of the southern district an increase of 7.5 per cent., and the railways of the western district an increase of 0.5 per cent. Operating expenses per mile increased 10.3 per cent. on the eastern railways, 8.3 per cent. on the southern railways, and 3.9 per cent. on the western railways. For the eastern railways net operating revenue per mile decreased 10.4 per cent., for the southern railways it increased 5.7 per cent., and for the western railways it decreased 4.8 per cent. Taxes per mile in the eastern district show a decrease of 0.4 per cent., in the southern district an increase of 6.9 per cent., and in the western district an increase of 14.0 per cent. Operating income per mile decreased 13.2 per cent. in the East, increased 5.6 per cent. in the South, and decreased 6.7 per cent. in the West.

Comparison of the returns for the three months of the current fiscal year with those of the corresponding months of the previous fiscal year reveals an increase in total operating revenues per mile of 2.5 per cent., an increase in operating expenses per mile of 7.6 per cent., and a decrease in net operating revenue per mile of 7.2 per cent. This net operating revenue per mile of the eastern railways decreased 11.1 per cent. as compared with the corresponding period of the previous year, that of the southern railways decreased 1.1 per cent., and that of the western railways decreased 4.7 per cent.

When the returns for the nine months of the calendar year 1913 are compared with those of the corresponding months of 1912, they show an increase in total operating revenues per mile of 6.4 per cent., an increase in operating expenses per mile of 9.1 per cent., and an increase in net operating

revenue per mile of 0.2 per cent. This net operating revenue per mile decreased 3.4 per cent. in the eastern district as compared with the corresponding period of the previous year, increased 3.7 per cent. in the southern district, and increased 3.1 per cent. in the western district.

The diagram shows the variation in operating revenues, operating expenses and net operating revenues per mile for the separate months of the calendar year 1912 and of the calendar year 1913 to date. The following table shows the per cent. of operating revenues consumed by each class of expenses:

	PER CENT. OF TOTAL OPERATING EXPENSES.					
	September.		Calendar year ending Dec. 31.		Nine months ending Sept. 30.	
	1913.	1912.	1912.	1911.	1913.	1912.
Maintenance of way and structures	13.6	13.1	12.8	12.7	14.0	13.0
Maintenance of equipment	16.5	15.1	16.0	15.7	17.1	16.2
Traffic expenses	1.9	1.9	2.0	2.1	2.1	2.1
Transportation expenses	33.0	32.1	35.5	35.4	35.9	36.0
General expenses	2.3	2.1	2.4	2.5	2.5	2.5
Total operating expenses	67.3	64.3	68.7	68.4	71.6	69.8

Uniform Freight Classification.

The Uniform Classification Executive Committee, which is composed of executive traffic officers of railroads representing the territories governed by the official, western and southern freight classifications, has sent to the Interstate Commerce Commission, through Chairman McCain, a statement showing the progress of the work looking to uniformity in the classification of freight throughout the country.

A special committee comprised of men formerly associated with the railroads and who have expert knowledge in matters relating to freight classification have been continuously employed for the last three years in the work of unifying the rules, descriptions of articles, packing requirements and minimum carload weights as appearing in the respective territorial classifications.

The conditions in the different sections of the country throughout which the existing classifications apply are varying, and these classifications have been adjusted to conform to the commercial and transportation necessities of such sections. The present effort is for the purpose of bringing about a standardization of shipping requirements as to rules, methods of packing, descriptions of articles, etc., which will be uniform throughout the United States.

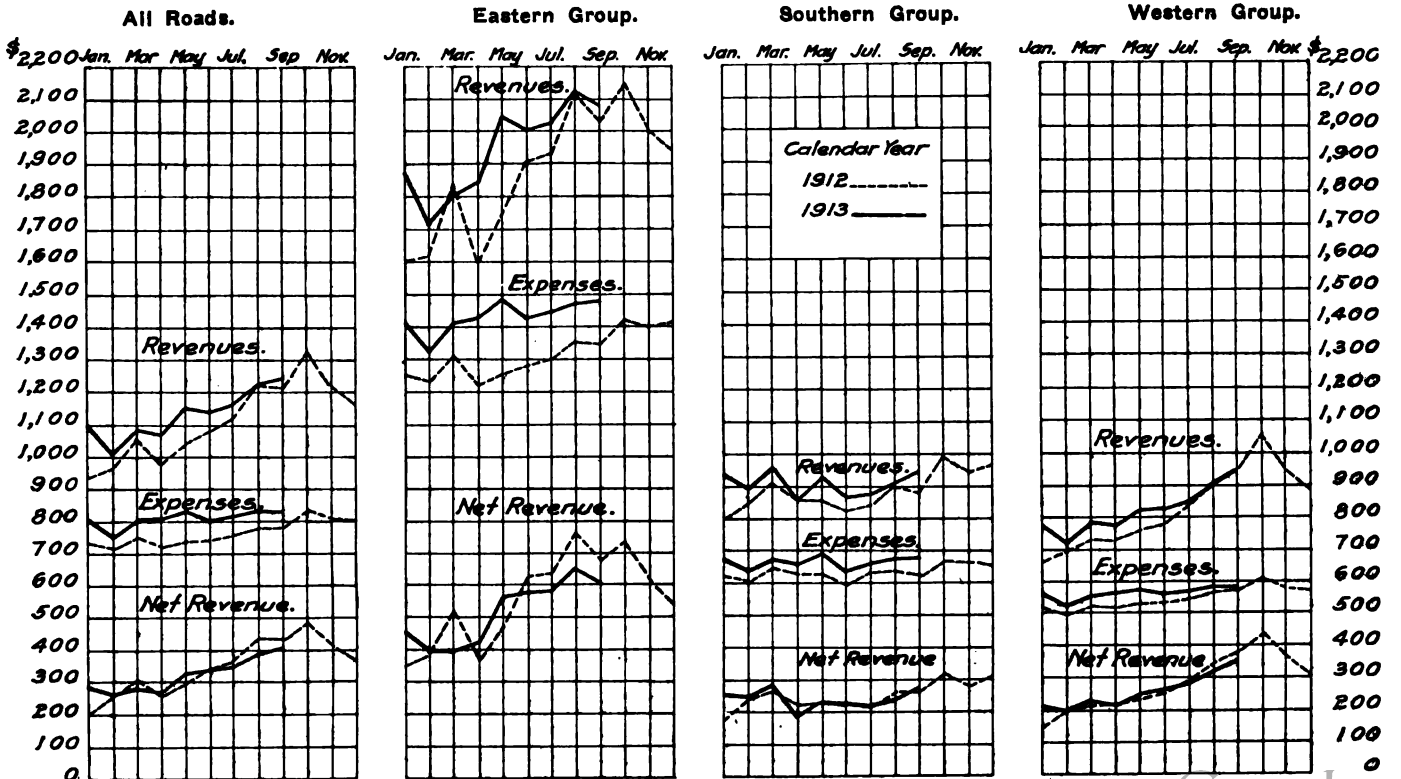

Monthly Revenues and Expenses Per Mile of Line in 1912 and 1913. Digitized by Google

When it is recalled that the respective classifications provide descriptions numbering from seven to nine thousand in each territory it will be appreciated that the work of unifying all such descriptions into terms which shall be alike for all sections and at the same time not disturb the commercial requirements or customs and suitably provide for every possible form of package that may be offered for shipment is a task presenting many difficulties and perplexities. The many phases of the subject must be carefully reviewed both from the standpoint of the carrier and of the shipper. It becomes necessary to study the freight rate question, industrial matters, the markets of production and consumption and to maintain for each article a harmonious relation to all other commodities to which it may commercially relate or with which it is competitive.

The committee has sought the co-operation of shippers, from whom information and advice is obtained, and under the methods followed every means has been accorded interested shippers to explain the character of their shipments, their particular requirements, and to suggest appropriate shipping descriptions and classification assignments of same. The shipping public has taken a great interest in the subject, and under the methods of the Uniform Committee, as well as those of the respective territorial committees, the fullest opportunity is afforded to be advised of the contemplated changes arising from the work of uniformity, as well as with respect to the incorporation of changes in the separate classifications governing the different sections.

It is considered by the carriers that the progress made has been as great as it would be under any competent method which could be devised for this purpose. The Uniform Committee has reviewed 65 per cent. of the material in the official classification, the same amount of that in the western classification, and 75 per cent. of that in the southern classification, which means that of the rules, descriptions of articles, minimum weights, etc., contained in the respective classifications the percentage stated for each has been analyzed and brought to the basis of uniformity for all. As this work has been completed, the sectional classification committees have adopted the recommendations of the Uniform Committee as rapidly as conditions would permit. Thus, of the total recommendations toward uniformity so far made, 75 per cent. have been incorporated in the official classification, a like percentage in the western classification, and between 80 per cent. and 90 per cent. in the southern classification. The remaining proportion between these percentages and the whole number of recommendations made by the Uniform Committee is under consideration and investigation for later adoption.

In view of the many complex questions arising in connection with this work it has necessarily taken a long time.

#### Freight Rates Into New Mexico.

The State Corporation Commission of New Mexico has complained to the Interstate Commerce Commission that rates on freight, both from the east and from the west, into that state, are too high as compared with rates to El Paso, and in general are discriminatory; and Commissioner Clements held a hearing on the complaint at Albuquerque last week. The State Commission presented testimony tending to show that as to many articles of every day commerce, it is cheaper to ship through New Mexico in either direction than to ship into New Mexico; that the rate from Kansas City to Gallup on certain commodities is the highest main line rate in the United States; that certain jobbers in Albuquerque are accustomed to fill orders direct from the manufacturer by way of El Paso in order to secure the lower rate and compete with El Paso merchants; and that in many instances the El Paso merchant can buy goods from the factory and reship them to Deming at a lower rate than the Deming merchant can buy the same goods in the same quantities direct. It was asserted that the wool scouring industry in Albuquerque had been killed by inequality in freight rates.

#### INTERSTATE COMMERCE COMMISSION.

Officers of the principal railroads in the anthracite coal territory gave testimony at Philadelphia last week in the Interstate Commerce Commission hearing, concerning the conditions under which the anthracite traffic is carried on. The hearing was abruptly terminated on the second day by reason of the illness

of Commissioner Marble, who was conducting the inquiry; which illness soon terminated fatally, as noticed below.

John H. Marble, the youngest member of the Interstate Commerce Commission, and also the youngest in length of service, died suddenly at his home in Washington on the evening of November 21, at the age of 46.



J. H. Marble.

Mr. Marble was taken sick while conducting a hearing in Philadelphia, on Thursday; and the illness, which at first was not deemed serious, proved to be uraemic poisoning, and ended fatally within less than two days. Mr. Marble was born in Ashland, Neb., February 26, 1869, and was educated at the University of Nebraska. He went to California and was admitted to the bar in that state in 1903. While living in San Francisco he became acquainted with Franklin K. Lane, now Secretary of the Interior, and when Mr. Lane went to Wash-

ington as a member of the Interstate Commerce Commission he soon engaged Mr. Marble for the service under that body. In 1912 he succeeded Edward A. Moseley, as secretary of the commission; and a year later, when Mr. Lane took a place in the cabinet, was appointed by President Wilson to succeed Mr. Lane as a member of the commission. At a public hearing held by the commission in Washington on Monday of this week, Chairman Clark, observing that the commissioners, if they followed their personal inclinations would suspend business for a time, paid a warm tribute to the personal character of Mr. Marble, whom he praised as a man of genial, helpful and splendid personality, indefatigable industry, sterling integrity, and broad fair-mindedness.

#### Express Rate Modifications.

##### *In re Express Rates, Practices, Accounts and Revenues.*

The commission has issued supplemental order No. 1 making certain modifications of the original order in this case, which was issued July 24, 1913.

#### Rates on Coal from Gallup, N. Mex.

##### *Arizona Corporation Commission v. Atchison, Topeka & Santa Fe. Opinion by the commission:*

The commission found that the rates for the transportation of coal in carloads from Gallup, N. Mex., to various points in Arizona were unreasonable and prescribed reasonable maximum rates for the future. (28 I. C. C., 428.)

#### Omaha-Oklahoma Fresh-Meat Rates.

##### *Opinion by Commissioner Meyer:*

The commission decided that the proposed increased joint rates on fresh meats in carloads from Omaha and South Omaha, Neb., St. Louis, Mo., East St. Louis, Ill., and St. Paul, Minn., to points in Oklahoma were not justified. (28 I. C. C., 454.)

#### Iowa-Minnesota Cement Rates.

##### *Opinion by Commissioner Meyer:*

Proposed increase in rate on cement from Mason City, Iowa, to International Falls, Minn., by the cancellation of the existing rate between these points, applicable also to intermediate stations, of 13 cents per 100 lbs., was found not to have been justified.

A rate otherwise reasonable is not shown to be unduly low by the presence in the carrier's tariff of a higher rate for a shorter distance involving a fourth section violation. Adjustment should be made with respect to the latter rate. (28 I. C. C., 477.)

### Scrap Iron Rates Between Duluth, Minn., and Chicago, Ill., and Other Points.

#### *Opinion by Commissioner McChord:*

The commission found that the proposed increased rates on scrap iron from Duluth and St. Paul, Minn., to Chicago, and between other points, were reasonable. The order of suspension was vacated. (28 I. C. C., 467.)

#### Reparation Awarded.

#### *Mason Brothers v. Southern Pacific et al. Opinion by the commission:*

The commission found that a combination rate of \$1.98 per 100 lbs. charged for the transportation of three carloads of grapes from Lodi, Cal., originally consigned to Minneapolis, Minn., and at that point reconsigned to New York, had not been authorized by defendants' tariffs. Reparation was awarded on basis of the lawfully published rate of \$1.15 per 100 lbs. (28 I. C. C., 402.)

#### Chicago Lighterage Charges.

#### *Opinion by Chairman Clark:*

Upon protests against the cancellation of the provision for the absorption by respondents of the charges of the Chicago River & Indiana for car-float deliveries in Chicago, such cancellations were suspended. Protestants either withdrew their protests or failed to appear at the hearing. It appearing that respondents can effect deliveries through other channels with less expense to themselves and without additional cost to the public, the order of suspension is vacated. (28 I. C. C., 390.)

#### Iowa Grain Rates Not Increased.

#### *Opinion by Commissioner Prouty:*

The commission decided that the proposed increases in rates on grain between stations on the line of Chicago, Milwaukee & St. Paul, between Spencer and Manilla, Iowa, and intermediate stations, which traffic passes through South Dakota, were unreasonable because they were constructed by applying the same interstate district scale on which similar rates, which were found unreasonable in *Sioux City Terminal Company v. C. M. & St. P.*, 23 I. C. C., 98, were constructed. The commission ordered the respondent to maintain the present rates for a period of two years. (28 I. C. C., 354.)

#### Carload Rates Applied.

#### *New England Electric Company v. Chicago, Rock Island & Pacific. Opinion by the commission:*

Complainant shipped one carload of wrought iron conduit pipe and fittings from Burr Oak, Ill., to Denver, Colo., being charged the carload rate for the pipe and the less than carload rate for the fittings. The commission held that the rate to be charged in a combined shipment of mixed carloads of wrought iron conduit pipe and of fittings made of the same material without bronze or brass parts or pieces should not exceed that on straight carloads of the articles named. (28 I. C. C., 418.)

#### Overcharges Collected.

#### *United Refrigerator & Ice Machine Company v. Chicago & North Western et al. Opinion by the commission:*

The commission held that a shipment of three ammonia compressors, condensers and receivers with oil traps and other appurtenances from Kenosha, Wis., to San Francisco was entitled to the rate provided for machinery, n. o. s., k. d., in pieces. (28 I. C. C., 439.)

#### Corn Rates to Wilmington.

#### *Boney & Harper Milling Company v. Atlantic Coast Line et al. Opinion by Commissioner Clark:*

The rate on corn from Cincinnati, Covington and Louisville to Wilmington, N. C., is 20 cents per 100 lbs. whether the traffic originates at that point or comes from beyond. From the same point to Charleston, Savannah, Brunswick and Jacksonville, the rate is 23 cents if the shipments have local origin or 21 cents if

they come from beyond. The commission finds that the present rate of 20 cents is not discriminatory to traffic from beyond the Ohio river to Wilmington and that while it may be well for the proportional rate to be less than the local rate it is not necessary in all cases that it should be so. (28 I. C. C., 383.)

#### Cars Not Misrouted.

#### *American Agricultural Chemical Company v. Bangor & Aroostook et al. Opinion of the commission:*

Complainant shipped four carloads of fertilizer from Searsport, Me., one to Fort Fairfield and three to Caribou and submitted bills of lading on which the route was specified as via the Canadian Pacific. A rate of 13 cents, that via the Bangor & Aroostook, Maine Central and Canadian Pacific, was noted on the bills of lading but not on the shipping orders submitted with them. The commission held that the cars had not been misrouted even though they had been sent by a longer route over the Canadian Pacific at a rate of 29 cents per 100 pounds, for the carrier's agent had fully complied with the instructions on the shipping orders. (28 I. C. C., 398.)

#### Rates on Lumber Not Increased.

#### *Wausau Advancement Association et al., v. Chicago & North Western. Opinion by Commissioner Marble:*

The complainants attack the existing rates for the transportation of lumber from Wausau, Schofield, Stevens Pt., Rib Lake, Tomah and Eau Claire, Wis., to points in southern Michigan taking Benton Harbor group rates. The commission finds that these rates are fairly in line with the rates from these points of origin to all points in central freight association territory, and that to change them would be condemnation of the entire rate adjustment from all northern Wisconsin points to all points in central freight association territory. The complaint was dismissed. (28 I. C. C., 459.)

#### Douglas, Ga., Discriminated Against.

#### *Mayor and Council of Douglas, Ga., et al. v. Atlanta, Birmingham & Atlantic. Opinion by Commissioner Meyer:*

The complainants allege that since the class and commodity rates from territory and points outside of Georgia to Douglas exceed those charged from the same points to Fitzgerald, Valdosta, Quitman, Thomasville, Moultrie, Tifton and Waycross, all in Georgia, there is a discrimination against the former city. The commission found that there was no real dissimilarity of circumstances as between Douglas and Fitzgerald and that controlling competition had not caused the discrepancy prevailing at the two cities; and held, therefore, that Douglas should be given the same rates as Fitzgerald and its common points Tifton, Quitman, Valdosta and Thomasville. The rates from the west to Douglas, however, should exceed those to Waycross which, east of it, is intermediate to it as compared to Brunswick and Savannah which have the advantage of water competition. (28 I. C. C., 445.)

#### Georgia Towns Discriminated Against.

#### *Town of Pelham, Ga., v. Atlantic Coast Line Railroad Company et al. Opinion by Chairman Clark:*

Upon complaints alleging undue discrimination in the adjustment of rates to and from Pelham, Camilla, and Sylvester, Ga., and undue preference to certain south Georgia basing points; The commission found that there is no substantial dissimilarity of circumstances or conditions affecting the transportation to Pelham and Camilla as compared with such basing points as Thomasville and Albany, Ga., nor in the transportation to Sylvester, as compared with Albany and Tifton, Ga., and decided that the discrimination was unreasonable. The defendants were ordered to remove this discrimination. (28 I. C. C., 433.)

#### Oklahoma Grain Rates.

#### *Opinion by Commissioner Meyer:*

The commission found that the proposed increase in rates on grain and grain products to Fort Smith & Western railroad stations in Oklahoma were not justified. The disagreement among participating carriers regarding the amount of their respective di-

visions of the through rate is not justification for increase in rates. (28 I. C. C., 462.)

#### Reparation Awarded.

*Morton Salt Company et al. v. Morgan's Louisiana & Texas Railroad & Steamship Company et al. Opinion by the commission:*

Morgan's Louisiana & Texas Railroad & Steamship Company filed and posted a tariff naming through rates of \$3 and \$3.975 per net ton on salt from Salt Mine, La., to Cape Girardeau, Mo., and Sulligent, Ala., respectively, in which the delivering line was not named as a party and had not concurred. Charges were collected on shipments from and to the points named on the basis of the combination of intermediate rates. The commission held that the complainant, having shown that it relied upon the rates as published, to its damage, is entitled to reparation against the carrier which issued the tariff. (28 I. C. C., 422.)

#### Lumber Rates from Texas, Louisiana, and Arkansas to Oklahoma and Missouri.

##### Opinion by Commissioner Meyer:

The commission decided that the proposed increase in rates on lumber from points on connecting lines of the Santa Fe in Texas, Louisiana and Arkansas, to Santa Fe destinations in eastern Kansas, extreme western Missouri, and northern Oklahoma, was not justified.

The proposed cancellation of joint rates on lumber from points on the Cotton Belt to Santa Fe destinations in Missouri and on cypress and yellow pine from points on the Missouri Pacific to Santa Fe destinations in Oklahoma were found not to have been justified.

A carrier should not be permitted to retain to itself the lumber market at points on its line for the benefit of producing points on its line, to the exclusion of producing points on other lines. (28 I. C. C., 471.)

#### STATE COMMISSIONS.

Tariffs filed by the western trunk lines, providing for team track storage charge, have been suspended in Missouri by the state public service commission until after a hearing in January.

The Public Service Commission of Massachusetts has denied the application of the Boston & Maine, asking that the commission's order requiring the installation of interlocking signals at South Lawrence be suspended. On the occasion of a collision at a junction at that point some months since, the commission ordered that ball signals—non-interlocking—be abandoned, and interlocking apparatus substituted; and, moreover, that all ball signals in Massachusetts be taken out of service by July 1, 1914. The road, in its application, claimed that the recent collision was not due to any defect in the signal system. The company is now in financial straits; and it has introduced automatic block signals more rapidly than has any other road in New England.

#### COURT NEWS.

The Wisconsin supreme court has granted the attorney-general of the state a writ of mandamus, compelling the Northern Pacific to show cause why it should not be compelled to file in the office of the secretary of state, amendments to its articles of incorporation increasing its capital stock. A fee of \$240,000 which the state claims in connection with the increase of stock is involved in the case.

The Supreme Court of New York holds that the New York Central must pay twice for injuries to Michael Greenberg, who had his leg cut off in 1902, when he was 10 years old, by a freight train in New York City. The road settled the case by paying \$3,000 to Leo Greenberg, the boy's father, who died in 1908; but in papers presented to the court by the boy he declares that his father had not filed a bond as his guardian and that he had not come into possession of any money. Counsel for the road produced a cancelled check for the payment, showing that it has been indorsed by the attorneys for the boy, but the court held the company liable for making payment without making sure that the guardian had filed a bond.

## Railway Officers.

#### Executive, Financial and Legal Officers.

John W. Crowell has been elected general auditor of the Bangor & Aroostook, with headquarters at Bangor, Me.

#### Operating Officers.

Harry G. Brown has been appointed trainmaster of the Waterloo terminals and the Albert Lea district of the Illinois Central, with headquarters at Waterloo, Ia., succeeding William Lamb, resigned.

J. S. Moore has been appointed assistant superintendent of the First and Second divisions of the Virginian Railway, and A. A. Kirkman has been appointed chief dispatcher of the First and Second divisions, both with offices at Victoria, Va.

E. E. Nash, superintendent of the Madison division of the Chicago & North Western at Baraboo, Wis., has been appointed assistant general superintendent of the lines east of the Missouri river except the Iowa, Minnesota and Dakota divisions, with headquarters at Chicago. J. W. Doyle, superintendent of the Minnesota division at Winona, Minn., has been transferred to the Madison division, succeeding Mr. Nash; M. J. Boyle, assistant superintendent of the Minnesota division, has been appointed superintendent of that division, succeeding Mr. Doyle; F. F. McCauley, trainmaster at Huron, S. Dak., has been appointed assistant superintendent of the Minnesota division at Winona, succeeding M. J. Boyle, and W. F. Carroll has been appointed trainmaster of the Dakota division, with office at Huron, succeeding Mr. McCauley.

#### Traffic Officers.

Henry Avila has been appointed district passenger agent of the Union Pacific System at San Francisco, Cal.

A. E. Lock has been appointed commercial agent of the Toronto, Hamilton & Buffalo, with headquarters at Hamilton, Ont.

W. B. Byrne, city passenger agent of the Chicago, Burlington & Quincy at Chicago has been transferred to Pittsburgh, Pa., as general agent of the passenger department.

Alex. Tinling, assistant general freight agent of the Northern Pacific at St. Paul, Minn., has been transferred to Tacoma, Wash., in a similar capacity, reporting to H. E. Still, general western freight agent. Effective December 1.

F. E. Mitchell, secretary and treasurer of the Chicago, Rock Island & Gulf, has been appointed commercial agent of the Kansas City, Mexico & Orient at Ft. Worth, Tex., succeeding Joseph P. O'Donnell, who has been appointed traffic manager of the latter road at San Angelo, Tex.

W. R. Trelford, traveling passenger agent of the International & Great Northern and the Texas & Pacific, with headquarters at Chicago, has been appointed Northern Passenger agent of the former road at Chicago, succeeding George W. Thomas, resigned to engage in other business.

W. L. Miles has been appointed traveling freight agent of the Western Maryland, with headquarters at Indianapolis, Ind. W. J. Mulvihill has been appointed traveling freight agent, with headquarters at Cincinnati, Ohio. T. J. Dowdell has been appointed traveling freight agent, with offices at Cleveland, Ohio, and S. F. Dagggett has been appointed traveling freight agent, with headquarters at Toledo, Ohio.

R. E. Lay, traveling freight agent of the Sunset-Central Lines of the Southern Pacific, with headquarters at Dallas, Tex., has been appointed division freight and passenger agent at Ft. Worth, Tex., succeeding S. W. Noble, division freight agent, deceased. T. H. Pointer is appointed traveling freight and passenger agent, with office at Ft. Worth. J. M. Farriss, division freight and passenger agent at Austin, Tex., has been transferred to Dallas as traveling freight and passenger agent. W. R. Smith, division freight agent at Galveston, Tex., succeeds Mr. Farriss. A. J. Morriss, traveling freight agent, with headquarters at Houston, takes the place of Mr. Smith at Galveston, and G. W. Adams, freight and ticket agent at Bay City, Tex., succeeds Mr. Morriss.

Henry Blakeley, who on December 1 becomes general freight agent of the Northern Pacific, with headquarters at St. Paul,

was born November 27, 1854, and was educated at the University of Minnesota, 1869 to 1873, and at Rensselaer Polytechnic Institute, 1873 and 1874. He has been connected with the Northern Pacific since 1888, when he began his railway career as clerk in the freight department. He was subsequently chief clerk in that department, and then was successively secretary to the general traffic manager and third vice-president, division freight agent, and assistant general freight agent, until August 1, 1905, at which time he was made general western freight agent at Tacoma, Wash. From this position he is now promoted to that of general freight agent, as above noted.

#### Engineering and Rolling Stock Officers.

John Kruttschnitt has been appointed mechanical inspector of the Illinois Central, with headquarters at Chicago.

Charles Flynn has been appointed roadmaster of the Chicago, Rock Island & Pacific at Des Moines, Iowa, succeeding J. Singleton, deceased.

James Wesly Gibbs, who has been appointed master mechanic of the Southern Railway, with headquarters at Sheffield, Ala.,

as has been announced in these columns, was born on August 31, 1873, in Rutherford county, N. C., and was educated in the High School, at Clyde, N. C. He began railway work in 1900 as a machinist on the Southern Railway, at Spencer, and three months later was made roundhouse foreman at the same place, remaining in that position until July, 1906; the following month he was promoted to engineer on the Asheville division. In March, 1908, he was made roundhouse foreman at Atlanta, Ga., later becoming general foreman at Asheville, N. C., on the same road.



J. W. Gibbs.

He was appointed master mechanic of the Virginia & South Western, in October, 1911, with headquarters at Bristol, Tenn., which position he held at the time of his recent appointment as master mechanic at the Southern Railway shops at Sheffield, Ala., as above noted.

A. M. Baird has been appointed assistant superintendent of the Atchison, Topeka & Santa Fe, in charge of the locomotive shops, with headquarters at Topeka, Kan., succeeding R. F. Whalen, resigned.

D. J. Brumley, engineer maintenance of way of the Illinois Central, has been appointed assistant chief engineer, with headquarters at Chicago. A sketch of his railway career was published in the *Railway Age Gazette* of April 18, 1913, page 923.

C. E. Johnson, chief engineer of the Kansas City Southern, announces that C. L. Wallace, office engineer at Kansas City, Mo., has been appointed assistant chief engineer, and assigned to service under the Federal Valuation Committee, with headquarters

#### Purchasing Officers.

In the *Railway Age Gazette* of November 14 it was stated that E. A. Clifford, who has been appointed assistant general purchasing agent of the Atchison, Topeka & Santa Fe, succeeded F. E. Connors, who has been appointed assistant to vice-president in charge of stores. This is slightly in error, as J. J. Conn succeeds Mr. Connors as senior assistant general purchasing agent and Mr. Clifford succeeds Mr. Conn as junior assistant general purchasing agent.

F. E. Connors, whose appointment as assistant to vice-president in charge of stores of the Atchison, Topeka & Santa Fe, with office at Topeka, Kan., has already been announced in these

columns, was born October 6, 1869, at San Francisco, Cal. He was educated in the public schools and began railway work August 15, 1886, as office boy in the purchasing department of the Chicago & Alton at Chicago. He was then successively clerk in the stationery department and stationer until October, 1890, when he went to the Santa Fe as clerk in the stationery department at Topeka. In May of the following year he was made chief clerk in that department and in May, 1895, was transferred to the purchasing department at Chicago in a clerical capacity. From October, 1900, to January, 1907, he was consecutively assistant chief clerk and chief clerk in the same department, and was then made assistant general purchasing agent, which position he held at the time of his promotion on November 15 to assistant to vice-president in charge of stores, as above:

#### OBITUARY.

T. M. Emerson, president of the Atlantic Coast Line died on November 25, at his home at Wilmington, N. C. An account of his life is given in another column.

W. W. Finley, president of the Southern Railway, died suddenly at his home in Washington, D. C., on Tuesday afternoon, November 25. He was stricken with paralysis at the breakfast table and sank rapidly. An account of his life is given in another column.

Horace I. Bettis, for the past 10 years auditor of the San Pedro, Los Angeles & Salt Lake, with headquarters at Los Angeles, Cal., died at Tipton, Cal., November 15. Previous to July, 1903, Mr. Bettis was for two years assistant general auditor of the Union Pacific.

James Charlton, chairman of the Transcontinental Passenger Association, died November 19 at his home in Chicago at the age of 81 years. He had been ill since the death of his



J. Charlton.

wife about four weeks ago. Mr. Charlton was born May 15, 1832, at Bothal, Northumberland, Eng. He began railway work in England in April, 1847, in the freight department of the Newcastle & Carlisle Railway at Newcastle - on - Tyne, where he was successively junior clerk, chief clerk and cashier, until March, 1857. He then came to Canada, and from April 29, 1857, to 1870, was employed by the Great Western of Canada as assistant to chief clerk in the audit office, in charge of statistics and freight accounts, and as chief clerk, auditor and general passenger agent. In March, 1870, he accepted a position as general ticket and passenger agent of the North Missouri, and in July of the following year he became general passenger and ticket agent of the Chicago & Alton. He held this position for almost 29 years, resigning January 1, 1900. In October of that year Mr. Charlton was made chairman of the Transcontinental Passenger Association. Two of Mr. Charlton's sons are in railway service, George J. Charlton as passenger traffic manager of the Chicago & Alton, and Alexander D. Charlton as assistant general passenger agent of the Northern Pacific at Portland, Ore. Train service on the Chicago & Alton was suspended for three minutes on November 21 in honor of Mr. Charlton.

BAGHDAD RAILWAY DEVELOPMENT.—The branch line of the Baghdad Railway from Toprak-kale to Alexandretta was opened on November 1.



## Equipment and Supplies.

### LOCOMOTIVE BUILDING.

THE JAMAICA GOVERNMENT has ordered three mikado locomotives from the Baldwin Locomotive Works.

THE ILLINOIS TERMINAL RAILROAD has ordered one mogul type locomotive from the Baldwin Locomotive Works.

THE ATCHISON, TOPEKA & SANTA FE has ordered 35 Pacific type locomotives from the Baldwin Locomotive Works.

THE SHELBY COUNTY RAILWAY has ordered one ten-wheel type locomotive from the Baldwin Locomotive Works.

THE ENTERPRISE LUMBER COMPANY, Goldsboro, N. C., has ordered one locomotive from the Baldwin Locomotive Works.

THE WHITEVILLE LUMBER COMPANY, Whiteville, N. C., has ordered one locomotive from the Baldwin Locomotive Works.

THE A. L. CLARK LUMBER COMPANY, Glenwood, Ark., has ordered one locomotive from the Baldwin Locomotive Works.

THE LAUREL RIVER LUMBER COMPANY, Jenningson, W. Va., has ordered one locomotive from the Baldwin Locomotive Works.

THE GREAT NORTHERN has ordered 25 Pacific type locomotives, 10 Mountain type coal-burning locomotives and 5 oil-burning Mountain type locomotives from the Lima Locomotive Corporation.

THE TRONA RAILWAY has ordered one oil-burning consolidation locomotive from the American Locomotive Company. The dimensions of the cylinders will be 23 in. by 30 in., the diameter of the driving wheels will be 57 in., the total weight in working order will be 203,000 lbs. and the steam pressure will be 200 lbs.

THE CHICAGO JUNCTION RAILWAY has ordered two superheater 6-wheel switching locomotives from the American Locomotive Company. The dimensions of the cylinders will be 21 in. x 26 in., the diameters of the driving wheels will be 51 in., the total weight in working order will be 149,000 lbs., and the steam pressure will be 180 lbs.

### CAR BUILDING.

THE MISSOURI, KANSAS & TEXAS is said to have ordered 200 Roger ballast cars and to be in the market for 1,000 stock cars. This item has not been confirmed.

THE NEW ENGLAND COAL & COKE COMPANY is said to have ordered 250 steel hopper cars from the Haskell & Barker Car Company. This item has not been confirmed.

THE LEHIGH VALLEY has ordered 500 steel underframes from the American Car & Foundry Company and 500 steel underframes from the Standard Steel Car Company.

THE ATCHISON, TOPEKA & SANTA FE, mentioned in the *Railway Age Gazette* of November 21 as having ordered 140 passenger train cars from the Pullman Company, placed that order as follows: 24 chair cars, 30 smoking cars, 35 coaches, 10 baggage cars, 6 partition cars, 15 dining cars, 10 composite cars and 10 parlor cars; all to be of all steel construction.

### SIGNALING.

The Nashville, Chattanooga & St. Louis is to install a 64-lever, all electric interlocking plant at Aulon, Tenn., near Memphis.

The Scranton & Binghamton (electric) road has ordered from the Union Switch & Signal Company automatic block signals, with track circuits, for the equipment of its line between Scranton and Nicholson, Pa., 26 miles. The contract amounts to about \$50,000. The same company has ordered a number of the Brach highway crossing signals. These signals are both visual and audible, the visual signal being a row of incandescent electric lamps, in red bulbs, which on the approach of a train are energized successively and repeatedly, so as to give an effect like the swinging of a red lantern.

## Supply Trade News.

The Northey-Simmen Signal Company, Ltd., Indianapolis, Ind., will, in the latter part of December, open a branch office in Buffalo, N. Y.

The Nathan Manufacturing Company, New York, has moved its general offices from 85 Liberty street, to 101 Park avenue, at the northeast corner of Fortieth street and Park avenue.

C. V. Kerr, the organizer of the Kerr Turbine Company, and later with McEwen Bros., Wellsville, N. Y., has accepted a position in the centrifugal pump department of the A. S. Cameron Steam Pump Works, New York.

Alexander A. Boutell, president of the Detroit Graphite Company, and former secretary of the Detroit Board of Commerce, died at Atlantic City, N. J., on November 22, at the age of 73. Mr. Boutell had been ill for nearly a year.

A. G. Machesney, for 15 years traveling engineer and locomotive inspector of the Baldwin Locomotive Works, Philadelphia, Pa., has taken a position in the railway department of the Detroit Lubricator Company, Detroit, Mich.

The Peoria & Pekin Union has for sale one second-hand standard 66-ft. Stroebel deck turntable, designed for a 200-ton engine, for immediate delivery. Applications should be made to R. H. Johnson, general manager, with office at Peoria, Ill.

J. H. Shugg, superintendent and engineer of winding, and for 24 years in charge of insulation of the General Electric Company, with office at Schenectady, N. Y., has been made engineer of insulation of the Sterling Varnish Company, Pittsburgh, Pa.

The Southern Railway has for sale one McKee gasolene motor car, seating capacity 79, baggage and express compartments, built in 1910. Inspection will be arranged for and price will be quoted upon application to the purchasing department, Washington, D. C.

Edward L. Adreon, Jr., president of the Adreon Manufacturing Company, St. Louis, Mo., died at his home in St. Louis on November 18 after an illness of four months. He was 41 years of age and had been president of the company, and its predecessor, Adreon & Co., for ten years.

The Pennsylvania Railroad has for sale two second-hand ferry boats. The *Baltimore* is at the shop at Hoboken, N. J., and the *Jersey City*, is in service on the Desbrosses street ferry, New York. They may be seen by applying to Capt. C. J. Carroll, superintendent of the Jersey City Ferries. Written offers must be submitted not later than December 15.

The Horne & Crane Engineering Company has been incorporated with office at 114 Liberty street, New York, to handle the Horne & Crane system of automatic train speed control and to conduct a general engineering business in railway and industrial specialties. Mr. Horne and Mr. Crane were formerly connected with the Interborough Rapid Transit Company, New York.

The Lackawanna Bridge Company and The Worden-Allen Company, engineers general contractors and steel fabricators whose shops are at Buffalo, N. Y., and Milwaukee, Wis., announce that J. W. Cowper, vice-president, in charge of the general contracting department, has removed his headquarters from New York to 612 Fidelity building, Buffalo. These companies will continue to make a feature of designing and constructing complete fireproof buildings and other structures, especially manufacturing plants, together with their regular steel fabricating and stock business.

The Merchants & Manufacturers Sales Syndicate has taken the fourth floor of the Grand Central Palace, New York, and will rent space to European manufacturers for the exhibition of their products. The organization is preparing an extensive advertising campaign to acquaint the buyers and merchants throughout the United States that such a department has been established and that it will prove to their advantage and profit to give these exhibits their special attention. It is believed that the products of more than 500 European companies will be exhibited and that more than 100 manufacturers will open their exhibits immediately.

The H. W. Johns-Manville Company, New York, has moved its Baltimore, Md., office to 207 East Saratoga street. This office is in a modern six-story building, 47 ft. x 187 ft. In addition to the store and offices there will be large warehouse accommodations. To facilitate the handling of incoming and outgoing shipments there will be a spur track running into the building. This company has moved its Columbus office and contract department to the ground floor of the new seven story Peters building, 45 West Long street, and has made provision for large warehouse facilities half a block distant. The Toledo office and warehouse have been moved to 213 Water street. The Cleveland office has just closed a long term lease for another larger warehouse on Front street, which, when remodeled, will give the branch larger and better storage and shipping facilities.

The McIntosh & Seymour Corporation has been incorporated in New York to make, on a large scale, a full line of Diesel engines, both stationary and marine. This company, which has a capital stock of \$2,200,000, half common and half 6 per cent. cumulative and participating preferred stock, will take over the plant and organization of the McIntosh & Seymour Company, Auburn, N. Y., builders of steam engines, and will continue its steam engine business. The directors of the new corporation are as follows: Marcus Wallenberg, president, Stockholms Enskilda Bank, Stockholm, Sweden; Frank A. Vanderlip, president, National City Bank, New York; Thatcher M. Brown, Brown Brothers & Company, New York; Edwin S. Church, Auburn, N. Y.; J. A. Seymour, Auburn, N. Y.; Franklin B. Kirkbride, New York; Oscar Lamm, Stockholm, Sweden, and Philip W. Henry, New York. Edwin S. Church will be the executive head of the new corporation and J. A. Seymour will be vice-president in charge of engineering.

At a meeting on November 20, a permanent organization was formed by exhibitors in the Permanent Manufacturers' Exhibit of Railway Supplies and Equipment located in the Karpen building, Chicago. The organization will be known as the Railway Supply Exhibit Association, and its purpose is to promote the interests of the railway supply business, and particularly of the exhibitors in the Karpen building. The association will endeavor to promote more cordial relations between the supply men and railway men, and will endeavor to interest railway organizations in taking advantage of the privileges of the assembly hall, club rooms and meeting rooms which are maintained in connection with the exhibit. Officers were elected as follows: President, A. F. Young, International Harvester Company; vice-president, J. Will Johnson, Pyle-National Electric Headlight Company; secretary-treasurer, W. F. Hebard; directors, A. B. Cross, Milwaukee Reliance Boiler Works; John Mack, Specialty Device Company; H. P. Teare, Colorado Supply & Manufacturing Company; F. D. Fenn, Crane Company; Henry Fisher, Verona Tool Works; F. C. Dinsmore, National Refining Company; Walter B. Wood, Forest City Paint & Varnish Company; H. A. Smith, Railway and Engineering Review, and F. E. Wade, Fairmont Machine Company.

#### TRADE PUBLICATIONS.

**CRANES.**—The Brown Hoisting Machinery Company, Cleveland, Ohio, has issued a leaflet describing the Brownhoist single I-beam hand-traveling crane.

**INDUCTION MOTORS.**—The Crocker-Wheeler Company, Ampere, N. J., has devoted bulletin No. 160 to a discussion of induction motors for general use.

**PNEUMATIC DRILLS.**—The Ingersoll-Rand Company, New York, has used form No. 8107, to describe and illustrate its line of Little David pneumatic drills.

**SAFETY TREADS.**—The American Mason Safety Tread Company, Lowell, Mass., has issued a booklet describing Mason safety tread and giving illustrations of its use.

**BUCKETS.**—The McMyler Interstate Company, Cleveland, Ohio, has published bulletin No. 29 illustrating its line of clam-shell and orange-peel buckets and giving lists of dimensions and prices.

**EXTENSION SIDE DUMP CARS.**—The Clark Car Company, Pittsburgh, Pa., has published catalog E-8, describing its extension side dump cars of from 12 to 20 cu. yds. capacity. These cars are hand or air operated or both.

## Railway Construction.

**ALBUQUERQUE, CORTEZ & SALT LAKE.**—Organized at Cortez, Colo., to build from Albuquerque, N. Mex., northwest to Salt Lake City, Utah. It is understood that financial arrangements are being made and that a contract has been given to the W. K. Palmer Co., engineer, Kansas City, Mo., to make the survey so that construction work can be started next spring. K. C. Kermodé, Cortez, is interested.

**ATLANTIC COAST LINE.**—An officer writes that the work now under way includes, building 50 miles in Florida from Dunnellon to Wilcox, and three miles from Moncrief to Export Terminals, Jacksonville. The contractors are Wade, Clower & Wade, Dunnellon, and the Smith-Kyle Company, Jacksonville. In addition the company is laying 50 miles of second track from Collier, Va., to Pleasant Hill, N. C., and the masonry for second track on 63 miles from Parkton, N. C., to Selma.

**BALTIMORE & OHIO.**—The report of this company for the year ended June 30, 1913, shows that work is now under way on a new double track line and a relocation of parts of the old line between Little Cacapon, W. Va., and Orleans Road. This improvement will connect the three-track line west from Little Cacapon and the three-track line east from Orleans Road, and when completed will provide a continuous three-track line all the way and four tracks part of the way between Patterson Creek and Cherry Run, a distance of 57 miles. It will effect a saving of 5.8 miles in distance and 877 deg. of curvature. The report shows that all the more important work authorized in the four years since July, 1909, has been completed and placed in operation, with the exception of the Magnolia cut-off. The work included extensions of first, second, third and fourth tracks, and the road is now double tracked from Philadelphia, Pa., to Chicago, with the exception of about 31 miles on the Chicago division, which will shortly be reduced to 23 miles. The line between Cumberland, Md., and Grafton, W. Va., is double tracked, and where necessary on the heavier grades, has three tracks. The line from Grafton to Parkersburg, W. Va., and thence to St. Louis, Mo., while mostly single track, is provided with ample sidings, principally lap, and so placed as to meet the requirements of the traffic.

**BOSTON & ALBANY.**—An officer writes that work is now under way relocating 2.11 miles of line at Middlefield, Mass. The Walsh Construction Company, Davenport, Ia., has the contract, and a sub-contract has been given to the Lathrop & Shea Co., New Haven, Conn.

**BUFFALO COAL & LUMBER RAILROAD.**—Surveys are being made and a grading contract is reported let to build from Cook's Mills, which is eight miles west of Cumberland, Md., through a timber and coal section for nine miles. Joseph Wolfe, Pittsburgh, Pa., is interested.

**CHICAGO, ST. PAUL, MINNEAPOLIS & OMAHA.**—An officer writes that a contract has been given to Winston Bros. Company, Minneapolis, Minn., to build an extension from Kaiser, Wis., to Park Falls, 5.99 miles.

**CINCINNATI, GEORGETOWN & PORTSMOUTH.**—See Ohio South-eastern System.

**COLORADO ROADS.**—According to press reports, plans are being made to build a line from Grand Junction, Col., southwest to San Diego, Cal. H. W. Huttig, H. A. Parkyn and R. E. Clapp, all of Chicago, are interested.

**COLUMBIA & NEHALEM.**—An officer of this company writes that the grading work is about 70 per cent. finished on the line building from Ross Landing, Ore., south 25 miles, except on a 1,700 ft. tunnel. The company is doing the work with its own forces on 20 miles, and Hansen & Hann is building the section from mile 9 to mile 13. The line is eventually to be extended south an additional five miles. E. A. Kyle, chief engineer, Portland (June 20, p. 1592).

**COLUMBIA & PUGET SOUND.**—An officer of this company, which operates a line from Seattle, Wash., to Franklin, 34 miles, and a number of branch lines, in all about 55 miles, writes that in addition to some re-alignment work, the company is making sur-

veys to build a branch from Renton Junction to Lake Washington, one mile.

**CUMBERLAND RAILROAD.**—An officer of this company, which operates a line from Artemus, Ky., south to Wheeler, 10.2 miles, writes that surveys are being made to build an extension from Jones Trestle, Ky., southwest to Jellico, Tenn., 24.2 miles.

**DENVER & SALT LAKE.**—Track laying on the extension from Steamboat Springs, Colo., west to Craig, 40 miles, has been completed and will be open for full passenger and freight service about December 1. The engineers appointed by the Tunnel Commission to estimate the cost of the construction of the tunnel through James Peak, report that it will cost about \$4,420,000 and can be completed in about four years. The city of Denver is to pay \$3,000,000, and the railroad company all above that amount. The report covers three possible locations and recommends that the lowest site, at an altitude of 9,100 ft., be selected. The tunnel is to be 31,886 ft. long and will effect a saving in elevation of 2,560 ft. and in distance of 22.6 miles.

**ESSEX TERMINAL.**—This company, which operates a line for freight traffic from a connection with the Grand Trunk to Sandwich, Ont., nine miles, and a one-mile branch writes that a contract has been given to J. J. Dewherst, of South Woodslee, Ont., to build from the present end of track at Sandwich, to the north limit of Ojibway, one mile. In addition the company has projected an extension from the north limit of Ojibway to a point near Turkey Creek, 2 miles. (October 24, p. 805.)

**FORT SMITH, POTEAU & WESTERN.**—An officer of this company, which operates a three-mile line from Poteau, Okla., to Witteville, writes that the company has projected an extension from Poteau east to Midland, Ark., 16 miles. In addition, surveys are being made to lay 2.5 miles of second track from Witteville to a connection with the Kansas City Southern.

**GAINESVILLE MIDLAND.**—An officer writes that work is now under way changing the Monroe branch from narrow gage to standard between Belmont, Ga., and Monroe, 32 miles.

**GLEN ROSE & WALNUT SPRINGS.**—This company has about completed grading work, it is said, on the line on which work was started four years ago, between Walnut Springs, Tex., and Glen Rose, and will soon start track laying. It will connect at Walnut Springs with the Texas Central. T. C. Lees, president. Walnut Springs.

**GRAND RAPIDS & NORTHWESTERN.**—An officer writes that a contract has been given to Maloney & Donaldson, to build from Crystal Valley, Mich., to Hesperia, 22 miles, T. R. Philbin, Ludington, chief engineer. (March 14, p. 529.)

**GULF, FLORIDA & ALABAMA.**—An officer writes that work is now under way from Broughton, Ala., to Pine Hill, 50 miles, by the Eastern Construction Company, Pensacola, Fla. The company has located a further extension from Pine Hill to Tuscaloosa, 147 miles. (October 17, p. 727.)

**HOCKING VALLEY.**—An officer writes that a grading contract has been given to J. B. Lindsey, Middleport, Ohio, to build a coal spur, 1.5 miles long, at Pomeroy, Ohio.

**HOOSAC TUNNEL & WILMINGTON.**—This company, which operates a line from Wilmington, Vt., to Hoosac Tunnel, 24 miles, has been changed from narrow to standard gage and surveys are under way for building an extension from Wilmington, east to Brattleboro, 26 miles.

**JOPLIN & PITTSBURG (Electric).**—An officer writes that the company finished work during 1913 on an extension of 1.61 miles in the city of Joplin, Mo.

**NEBRASKA CENTRAL.**—Incorporated in South Dakota with \$750,000 capital, and headquarters at Pierre, S. Dak., and a branch at Ainsworth, Neb. The plans call for building 55 miles of railway in Brown and Keyapaha counties, Neb., and 75 miles in Tripp and Lyman counties, S. Dak. The incorporators include: G. W. Adams, Walnut, Iowa; W. F. Finney, Ainsworth, Neb., and J. A. Holmes, Pierre, S. Dak.

**NEW RIVER, HOLSTON & WESTERN.**—An officer of this company, which operates a line from Narrows, Va., west to Rocky Gap, 21 miles, writes that a contract has been given to J. J. Boxley & Son, Roanoke, Va., to build an extension from Rocky Gap to Suiters, in Bland county, 15 miles.

**NEW YORK SUBWAYS.**—A contract was recently let for Section No. 3 of the Seventh avenue subway in the borough of Manhattan, to the Degnon Contracting Company, the lowest bidder, for \$2,185,063. This contract calls for the construction of a four-track underground railroad in Varick street and Seventh avenue extension between Beach street on the south and Commerce street on the north. It is the first contract awarded for the Seventh avenue subway line, which will be operated by the Interborough Rapid Transit Company in connection with the existing subway. All bids were rejected for Section No. 2, immediately south of Section No. 3. The lowest bidder was the Thomas J. Buckley Engineering Company, New York, and the New York Public Service Commission, Second district, has readvertised for bids, to be opened on December 2. The commission also let a contract for the construction of Section No. 5 of the Seventh avenue subway, lying in Seventh avenue between Sixteenth street on the south and Thirtieth street on the north to the Canavan Brothers Company, the lowest bidder, for \$2,401,306. The last public hearing on the forms of contracts for the Jerome avenue branch of the Lexington avenue subway was held last week, and bids for Section No. 1 of this line, extending from 157th to 182nd street, will be opened on November 28.

The New York Public Service Commission, Second district, has let a contract for the construction of the Queens extension of the Steinway tunnel from its present terminus in Long Island City, in the borough of Queens, to the Queensboro bridge, and a connection with the Corona and Astoria rapid transit lines, to the Degnon Contracting Company, New York City, for \$557,856; the lowest bidder. The commission also opened bids for the construction of the proposed elevated railroad in New Utrecht avenue, borough of Brooklyn, from Thirty-ninth street and Tenth avenue to Stillwell avenue and Avenue Y, near Coney Island. The lowest bidder for this work was Post & McCord, Incorporated, New York City, who offered to do the work for \$1,672,000. This contract will probably be let this week.

**NIAGARA, ST. CATHERINES & TORONTO (Electric).**—An officer writes that the company finished work during 1913 on 12 miles of line in the province of Ontario from St. Catherines to Niagara-on-the-Lake.

**NORMAN INTERURBAN.**—See Oklahoma Railway.

**NORTHWESTERN PENNSYLVANIA (Electric).**—An officer of this company, which operates a line from Linesville, Pa., to Erie, 57 miles, writes that surveys are being made to relocate the line on a 14-mile section between Meadville and Cambridge Springs.

**OHIO SOUTHEASTERN SYSTEM.**—An officer of the Ohio River & Columbus writes that surveys are being made for an extension from the southern terminus at Ripley, Ohio, southeast, following the shore of the Ohio river to Manchester, 20 miles.

An officer of the Cincinnati, Georgia & Portsmouth writes that the company is making surveys for an extension from the present end of track at Russellville, Ohio, east to West Union, nine miles.

**OHIO RIVER & COLUMBUS.**—See Ohio Southeastern System.

**OKLAHOMA RAILWAY (Electric).**—This company recently finished work on the extension built under the name of the Norman Interurban, from Moore, Okla., south, thence southeast, to Norman, 8.2 miles. The company plans next year to build an extension from the northern terminus at Edmond, north to Guthrie, 16 miles. G. Treat is chief engineer of the Norman Interurban. (August 22, p. 353.)

**PALESTINE, CORSICANA & DALLAS.**—This company is building from Palestine, Tex., northwest to Corsicana, 60 miles, it is said, and considerable grading has been done on the line, which will pass through timber lands and will open up a rich agricultural section. The valley of the Trinity river will be followed for part of the route. L. E. Mitchell, president.

**PENNSYLVANIA RAILROAD.**—An extension of the Hillman branch has been built to Clover Run Mine No. 2 of the Madeira-Hill Coal Mining Company, 1.41 miles, and is now operated as a part of the Bellwood division.

**RAPID RAILROAD.**—An officer of this company, which operates a freight line between Chesterfield, New Baltimore, Anchorville, Fair Haven, Algonac and Marine City, a total of 28 miles, writes that surveys are being made for an extension south, via Mt. Clemens, to Detroit, 15.25 miles.

## Railway Financial News.

**ST. LOUIS SOUTHWESTERN.**—An officer writes that the company has some of the grading work finished for second track between Rockview, Mo., and Paront, 31.8 miles.

**SALT LAKE & ALTA.**—This company, which was incorporated in Utah, to build about 11 miles of line, has completed the work, it is said, from Midvale, Utah; via Wasatch to the granite quarries of Little Cottonwood canyon. J. G. Jacobs, president. (September 5, p. 436.)

**SHEFFORD, BAGOT & MISSISQUOI.**—This company has been organized in Canada with \$1,000,000 capital, to build a line through the counties of Missisquoi, Brome, Shefford and Bagot, from Clarenceville, Que., Missisquoi county, northeasterly via a point near Adamsville, thence connecting Granby, Roxton, Pond, Milton with East, St. Valerien, in Shefford county, and from a point near Upton to a connection with the Intercolonial Railway between Bagot and St. Eugene, Bagot county, with two branch lines. W. H. Robinson, Granby; A. R. McMaster, Montreal and A. W. Runnels, Springfield, Mass., are interested.

### RAILWAY STRUCTURES.

**BALTIMORE, MD.**—The Pennsylvania Railroad has given a contract to Irwin & Leighton, Philadelphia, Pa., to build a new freight house at President street, in Baltimore. The work involves the construction of a new brick freight warehouse, 610 ft. long x 45 ft. wide, with a second story office portion 333 ft. long, together with the rearrangement of tracks and driveways. The freight house will be of brick construction on a concrete foundation, with wood block floor laid on a concrete base inside the building, and a creosoted wood block floor on a concrete slab on the platform on the track side of the building. The second floor will be carried on steel girders, spanning from wall to wall, these girders supporting a reinforced concrete floor slab.

**CHAMBERSBURG, PA.**—The Cumberland Valley will build a new general office building on the west side of the driveway leading from Market street to the new passenger station now nearing completion at Chambersburg. Irwin & Leighton, of Philadelphia, have the contract for its erection above the concrete foundations, which the railroad company is now building. It will be a four-story brick and steel building, 109 ft. x 81 ft., with a light well in the rear. The floors will be of steel beam and hollow tile arch construction with a covering of concrete, and the roof will be of reinforced concrete slab construction on steel beams, and waterproofed with asphalt. It is expected that the building will be ready for business by June 1, 1914.

**RALSTON, NEB.**—The Missouri Pacific has announced that work is to be started early next year on the construction of large freight yards near Ralston, to cost about \$1,000,000.

**ST. PAUL, MINN.**—Edmund Pennington, president of the Minneapolis & St. Louis, has been elected president of the St. Paul Union Depot Company, succeeding A. W. Trenholm. A meeting of the directors was held in Chicago on November 20 to discuss the purchase of property owned by the Chicago, Milwaukee & St. Paul and Great Northern which will be required for the construction of the proposed new station. It is understood these companies will formulate terms for the purchase of the property to be presented at the next meeting.

**RAILROAD CONSTRUCTION IN VICTORIA.**—There are now in course of construction, or about to be commenced, lines computed to cost \$7,500,000. With the exception of \$750,000, laid out on the East Gippsland extension, the greater part of this sum has yet to be expended. Among the lines in course of construction are: Bairnsdale to Orbost, 60 miles, estimated cost \$2,000,000; Benalla to Tatong, 18 miles, estimated cost \$310,000; Bosworth to Colbinabbin, 12 miles, estimated cost \$210,000; and Crowland to Navarre, 23 miles, estimated cost \$400,000, &c. Work on the following new lines will be commenced: Elmore to Cohuna, 57 miles, estimated cost \$1,020,000; Tallangatta to Cudgewa, 42 miles, estimated cost \$1,500,000; and Swan Hill to Piangil, 27 miles, estimated cost \$450,000. Under the agreement with Victoria, South Australia is also to build a line from Pinnaroo to Murrayville, in the mallee, 17 miles, and estimated to cost \$329,000, Victoria making the extension from Heywood.

**BOSTON, REVERE BEACH & LYNN.**—On November 20 the stockholders voted to rescind the vote taken on March 30, 1912, authorizing the issuance of \$170,000 additional stock, at \$110 per share, and to issue this stock at \$100 a share. This company has sold \$150,000 4½ per cent. first mortgage bonds maturing in 1927, being the remainder of the \$1,000,000 of these bonds authorized. The proceeds of the sale of these securities will be used to retire the \$290,000 note outstanding on June 30, 1913.

**CHICAGO & WESTERN INDIANA.**—This company has called for payment at the office of J. P. Morgan & Company, New York, 116,000 6 per cent. general mortgage bonds of 1882, at \$105.

**FORT WORTH & DENVER CITY.**—E. I. Grenfell has been elected a director, succeeding S. M. Hudson, deceased.

**GALVESTON, HOUSTON & HENDERSON.**—The stockholders will vote on January 19, 1914, on the question of authorizing a new issue of \$5,000,000 first mortgage 5 per cent. bonds to be dated April 1, 1913, when the \$2,000,000 old first mortgage 5 per cent. bonds matured and were purchased by the Central Trust Company, New York. The new bonds will mature April 1, 1933.

**GEORGIA & FLORIDA.**—Holders of more than 75 per cent. of the first mortgage 5 per cent. bonds (exclusive of \$630,000 treasury bonds) have agreed to fund their coupons under the agreement dated August 15, 1913. It is believed that consent will be obtained from the holders of substantially more than 80 per cent. of these bonds before long. The company has therefore determined to carry through the plan with the assent of the holders. In the interest of the bondholders it has been decided to make certain changes in their agreement. Under the new plan the coupons will not be effectively extended except as they severally mature, and, therefore will not be postponed as to participation in a dividend in the event of a foreclosure sale, as provided by the mortgage, except as they severally mature. Further, under this plan, separate notes will be issued by the railway in exchange for the separately maturing coupons, and not one note for all six coupons. As each coupon matures the appropriate note will be issued therefor. The plan thus modified is, in the judgment of officers of the railway, greatly in the interest of the bondholders, and, it is believed, will be assented to by approximately 90 per cent of all the bondholders.

**ILLINOIS CENTRAL.**—The special meeting of the stockholders to authorize the making of a new refunding mortgage for not exceeding \$120,000,000 on the Southern lines, has been postponed to December 12, 1913.

**NEW YORK CENTRAL & HUDSON RIVER.**—The New York Public Service Commission gave its approval on November 20, to the execution of the new mortgages called for by the financial plan described in the *Railway Age Gazette* of May 16, 1913. It was pointed out by the commission that this approval of the mortgages did not involve approval in advance of the proposed consolidation of the Lake Shore & Michigan Southern; the Pittsburgh & Lake Erie; and the Michigan Central with the New York Central & Hudson River nor to the exchange of the present 3½ per cent. collateral bonds for 4 per cent. bonds, except in the case of such consolidation.

**NEW YORK CONNECTING.**—J. P. Morgan & Company and Kuhn Loeb & Company, both of New York, have sold \$11,000,000 first mortgage 4½ per cent. bonds of this company, due August 1, 1953, at 94½. These bonds are guaranteed, principal and interest, jointly by the Pennsylvania Railroad and the New York, New Haven & Hartford.

**OCEAN SHORE.**—Stockholders will vote on January 9, on the question of authorizing \$5,000,000 bonds. Of this amount \$200,000 will be issued immediately and the proceeds will be used for change of motive power, additional sidings, etc.

**RAILWAYS BETWEEN FRANCE AND SPAIN.**—The three lines of railway through the heart of the Pyrenees between France and Spain, now under construction, will be of great commercial value as shorter and more direct means of transit than have hitherto existed. The line between Jaca, Spain, and Oloron, France, will be finished, it is thought, in 1917.

# ANNUAL REPORT.

## THE BALTIMORE & OHIO RAILROAD COMPANY—EIGHTY-SEVENTH ANNUAL REPORT.

OFFICE OF THE BALTIMORE AND OHIO RAILROAD COMPANY,  
BALTIMORE, MD., October 9, 1913.

To the Stockholders of The Baltimore and Ohio Railroad Company.  
The President and Directors herewith submit report of the affairs of the Company for the fiscal year ended June 30, 1913.

### PROPERTIES AND MILEAGE.

The statements in this report show the results of the operations of the line directly operated by The Baltimore and Ohio Railroad Company, embracing:

Miles of Road .....	4,382.69
Trackage Rights .....	73.64
<b>Total Operated Mileage .....</b>	<b>4,456.33</b>

as shown in detail in Table 28.

There has been an increase of 1.27 miles in first main track, due mainly to remeasurement.

### INCOME FOR THE YEAR.

The General Income Account of the Company will be found in Table 1. Except where otherwise indicated, the comparisons herein shown are with the figures of the preceding fiscal year.

The total Operating Revenue (including Outside Operations), was \$103,329,992.32, an increase of \$9,289,397.66, or 9.88 per cent.

The total Operating Expense (including Outside Operations), was \$76,427,809.59, an increase of \$9,605,360.22, or 14.37 per cent.

The total Net Railway Operating Revenue (including Outside Operations), was \$26,902,182.73, a decrease of \$315,962.56, or 1.16 per cent.

The Gross Earnings from Rail Operations were \$101,556,131.62, an increase of \$8,961,808.75, or 9.68 per cent.

The earnings from Freight Traffic were \$80,194,489.95, an increase of \$7,728,945.67, or 10.67 per cent.

The tons of freight carried were 72,461,064, an increase of 7,756,994 tons, or 11.99 per cent. The tons of revenue freight carried one mile were 14,313,128,233, an increase of 1,822,709,436, or 14.59 per cent. The average distance each ton was carried was 197.53 miles as compared with 193.04 miles the previous year. The ton miles per mile of road were 3,211,865, an increase of 408,217, or 14.56 per cent. The revenue from freight per mile of road was \$17,995.64, an increase of \$1,729.74, or 10.63 per cent. The revenue per freight train mile was \$3.47 18/100, an increase of \$.25 50/100, or 7.93 per cent. The average earnings per ton per mile were 560/1000 cents, a decrease of 20/1000 cents. Freight Traffic Statistics are given in Tables 12 and 13.

From the Statement of Commodities Carried, Table 14, it will be seen that as compared with the previous year there were marked increases in the commodities grouped as Products of Agriculture, Products of Mines, Products of Forest, and Manufactures, with decreases in Products of Animals. There was also a decrease in less carload shipments, which are classified in the grouping of Merchandise.

The earnings from Passenger Traffic were \$15,537,077.83, an increase of \$782,166.12, or 5.30 per cent.

The number of passengers carried was 22,879,239, an increase of 700,941, or 3.16 per cent. The number of passengers carried one mile was 805,206,527, an increase of 39,036,651, or 5.10 per cent. The average number of miles each passenger was carried was 35.19, an increase of .64 miles, or 1.85 per cent. The number of passengers carried one mile per mile of road was 180,688, an increase of 8,711, or 5.07 per cent. The average earnings from each passenger was \$.67 91/100, an increase of \$.01 38/100, and the average earnings per passenger per mile was \$.01 930/1000, an increase of 4/1000 cents. Passenger Traffic Statistics will be found in Tables 10 and 11.

The earnings from Express Traffic were \$1,909,551.96, an increase of \$162,848.77, or 9.32 per cent., and from the Transportation of Mails \$1,205,158.95, an increase of \$84,996.96, or 7.59 per cent.

The Operating Expenses for the year were \$73,779,637.98, an increase of \$9,070,100.39, or 14.02 per cent.

The ratio of Expenses to Earnings increased 2.77 per cent., being 72.65 per cent. for the present fiscal year compared with 69.88 per cent. for the preceding fiscal year.

The expenditures for Maintenance of Way and Structures were \$14,019,619.57, an increase of \$2,654,165.28, or 23.35 per cent.

The expenditures for Maintenance of Equipment were \$18,323,210.39, an increase of \$1,671,675.99, or 10.04 per cent.

The total maintenance expenses for the year were \$32,342,829.96, as against \$28,016,988.69 for the preceding year, an increase of \$4,325,841.27, or 15.44 per cent. The total amount expended for maintenance was 31.85 per cent. of the Gross Earnings and 43.84 per cent. of the total Operating Expenses. These expenses include \$576,241.92 account of directly locatable expenses incident to flood damage, \$794,143.28 incident to the reconstruction and revision of existing facilities, and \$2,919,795.69 for the depreciation of equipment. Additional depreciation to the extent of \$36,895.28 was charged to Outside Operations.

In March, 1913, the Middle West was visited by an unprecedented flood which seriously affected a large section of the Company's lines in Ohio, Indiana and Pennsylvania, with lesser difficulties on practically the entire system. Eleven important bridges were destroyed, and seven bridges were seriously damaged; one hundred and seventy-nine miles of main track were washed out, four hundred and five miles of line having been under water and more or less seriously damaged. Not only was the line broken in many places, but owing to the volume of flood water it was from twenty-four to seventy-two hours before effective work of restoration was possible. The traffic on the major part of the system was suspended for several days, the Southwestern District between Cincinnati, O., and St. Louis, Mo., being broken for thirty days, and between Cincinnati, O., and Parkersburg, W. Va., twelve days, and the interruption to business, serious for several weeks, was felt throughout the balance of the year. Schedules were resumed as promptly as possible but owing to broken lines, both in the system and on connections, relatively little traffic was handled. It is estimated that the Company suffered a loss of traffic of not less than \$1,500,000.00.

The necessity to place and keep a large number of work-trains on the line, with day and night gangs; the renting of pile drivers and other special equipment, and the purchase of emergency material in competition with the many other lines affected, all tended to enhance the expense of repairs; and the interference of regular train movements, together with bills for detouring via other lines, resulted in greatly increased transportation costs.

The estimate to overcome the physical damage from the flood was placed at approximately \$3,000,000.00. While the lines were all promptly restored, some of the permanent work, such as replacement of steel structures, remains to be completed, and it is estimated that the charges on this account, extending over several months, may aggregate \$1,500,000.00.

The total cost of conducting transportation was \$37,274,397.06, an increase of \$4,523,162.71, or 13.81 per cent. over the preceding year. The ratio of Transportation Expenses to Gross Earnings was 36.70 per cent. as compared with 35.37 per cent. last year. The increased cost of conducting transportation was brought about partly by the larger volume of traffic handled and partly by the unusual expense above referred to in connection with the March floods, and also by the higher wages and increased cost of fuel and certain other material. The transportation expenses also reflect directly the increased cost of service due to higher standards now demanded, particularly as concerns safety and dispatch. The comparisons shown in Table 7 indicate the general increases in the various accounts of Transportation Expenses.

The Net Revenue—Rail Operations was \$27,776,493.64, a decrease of \$108,291.64, and Outside Operations show a deficit of \$874,310.91, making the Net Railway Operating Revenue \$26,902,182.73; from this amount should be deducted Railway Tax Accruals for the year, \$2,960,905.09, an increase of \$177,710.22, or 6.39 per cent., leaving as Railway Operating Income \$23,941,277.64, a decrease from preceding year of \$493,672.78, or 2.02 per cent.

Other Income amounted to \$5,212,206.03, an increase of \$869,313.58, making the Gross Income for year \$29,153,483.67, an increase of \$375,640.80, as compared with last year.

There was deducted from Gross Income for payment of interest on funded debt, rents, etc., \$15,771,372.29, as set forth in the Income Account, leaving as Net Income \$13,382,111.38, being a decrease of \$558,340.30 under that of the previous year, from which dividends were paid at rate of 4 per cent. on Preferred Stock, \$2,354,891.36, together with some minor appropriations to sinking and reserve funds, leaving a balance to be transferred to Profit and Loss of \$10,979,359.33. With this transfer and after deductions incident to miscellaneous adjustments and charges for discount on securities sold during the year, the net balance to the credit of Profit and Loss was \$46,531,137.76, out of which dividends were paid at rate of 6 per cent. on your Common Stock, aggregating \$9,120,975.68, leaving a credit to Profit and Loss as of June 30, 1913, of \$37,410,162.08.

### CHANGES IN CORPORATE RELATIONS.

In furtherance of the plan to simplify the title to the properties under the various System mortgages, and to reduce the number of organizations in the respective States, the following purchases and mergers were effected during the year.

Your Company acquired by purchase the property of the following corporations owning railroads in West Virginia, the operations of which are included in the System as heretofore, viz:

- Berkeley Springs Railroad Company,
- Cherry Run and Potomac Valley Railroad Company,
- Grafton and Belington Railroad Company,
- Huntington and Big Sandy Railroad Company,
- Monongahela River Railroad Company,
- Ohio River Railroad Company,
- Parkersburg Branch Railroad Company,
- Ravenswood, Spencer and Glenville Railway Company,
- Ripley and Mill Creek Valley Railroad Company,
- South Branch Railroad Company,
- West Virginia Short Line Railroad Company,
- Fairmont, Shinnston and Clarksburg Railroad Company,
- Point Pleasant, Buckhannon and Tygarts Valley Railroad Company,
- Patterson Creek and Potomac Railroad Company,
- Paw Paw Railroad Company,
- West Virginia and Pittsburgh Railroad Company.

The purchase price of these properties represented the investment of The Baltimore and Ohio Railroad Company in the securities of, and capital advances to, these companies at the time of acquisition.

The following properties located in Pennsylvania and maintaining separate organizations, the operations of which have heretofore been included in those of the System, viz:

- Pittsburgh and Connellsville Railroad Company,
- Berlin Railroad Company,
- Salisbury Railroad Company,
- Mount Pleasant and Broad Ford Railroad Company,
- Ohio and Baltimore Short Line Railroad Company,
- Somerset and Cambria Railroad Company,
- Fayette County Railroad Company,
- Glenwood Railroad Company,

were merged into a new corporation called The Baltimore and Ohio Railroad Company in Pennsylvania. Under the agreement of merger your Company received bonds of the new corporation in payment for capital advances made up to the time of merger, and surrendered its holdings of stock of the old companies in exchange for stock of the new company.

The investment of your Company has not been increased by reason of purchasing the properties of the West Virginia corporations and of the merger of the Pennsylvania corporations; the only effect being to change the form of the investment, which is reflected in the Balance Sheet groupings of Road, and Securities of Proprietary, Affiliated and Controlled Companies—Pledged and Unpledged.

### ASSETS.

The General Balance Sheet will be found in Table 2.	
Property Investment—Road and Equipment—shows a net increase for the year of.....	\$10,386,885.23
arrived at as follows:	
Total Expenditures for Road (See Table 6).....	\$10,390,303.75
Miscellaneous Expenditures—Net .....	5,779.77
	<hr/>
Net Increase in Equipment.....	\$10,396,083.52
Acquisition by purchase of West Virginia properties formerly represented by securities in groupings—	4,688,637.94
Securities—Pledged .....	\$13,647,537.79
Securities—Unpledged .....	341,310.02
	<hr/>
	13,988,847.81
	<hr/>
Total .....	\$29,073,569.27
Less: Capital Advances to Pennsylvania properties formerly carried in Road account but now represented by securities .....	18,686,684.06
	<hr/>
	\$10,386,885.23

Property Investment—Securities—shows a net increase of: \$31,691,895.86 which is occasioned in the following manner:  
The grouping of Securities of Proprietary, Affiliated and Controlled Companies—Pledged shows a net increase of: \$5,376,527.27 due to:

Purchase of additional securities of subsidiary lines .....	\$15,171.00	
Securities of The Baltimore and Ohio R. R. Co. in Pennsylvania, received in liquidation of capital advances to constituent companies, formerly carried in Road account .....	\$18,686,684.06	
and Securities Unpledged... ..	322,210.00	
		19,008,894.06
		\$19,024,065.06
Less: Value of securities of West Virginia corporations, the properties of which have been purchased and transferred to Road account .....	13,647,537.79	
		\$5,376,527.27
Securities of Proprietary, Affiliated and Controlled Companies—Unpledged increased .....	26,315,368.59	
occasioned by:		
Bonds heretofore pledged as security for Three Year Gold Notes, transferred from Other Investments—Miscellaneous .....	\$25,000,000.00	
Purchase of additional bonds of The Baltimore and Ohio Chicago Terminal R. R. Co. ....	1,800,000.00	
Purchase of sundry other securities of subsidiary companies .....	209,422.66	
		\$27,009,422.66
Less: Value of securities of West Virginia Corporations the properties of which have been purchased and now transferred to Road account .....	\$341,310.02	
Value of securities of Pennsylvania properties transferred to Securities Pledged .....	322,210.00	
Miscellaneous adjustments .....	30,534.05	
		694,054.07
		\$26,315,368.59
		\$31,691,895.86

Property Investment—Other Investments—indicates a decrease for the year of: \$20,445,019.10 accounted for in the following manner:

Increase in Advances to Proprietary, Affiliated and Controlled Companies, mainly representing the cost of the Sandy Valley & Elkhorn R'y Co. ....	\$4,233,441.26
Increase in Miscellaneous Investments—Physical Property, being principally occasioned by purchases of additional real estate .....	\$119,975.36
Increase in Miscellaneous Investments—Securities Unpledged, by reason of the release of certain collateral securities last year carried in Securities Pledged....	\$21,673,284.00
Securities Acquired .....	201,564.28
	21,874,848.28
	\$21,994,823.64
Less: Decrease in Securities Pledged, being securities carried in this account last year, now transferred to other groupings.....	46,673,284.00
Net Decrease .....	24,678,460.36
	\$20,445,019.10

Working Assets show a net increase of \$7,366,737.64, due mainly to increases in Cash, Loans and Bills Receivable, and Materials and Supplies; a decrease in Securities Issued—Held in Treasury, and a considerable decrease in Net Balance Due from Agents and Conductors. To the \$3,021,250.00 First Mortgage Bonds carried in Securities Issued—Held in Treasury, shown in the last report, \$1,000,000.00 were added during the year under provision of that mortgage in recoupment of expenditures made for capital purposes, and \$2,000,000.00 were disposed of for treasury purposes, which transactions, together with sundry adjustments, occasion the decrease of \$913,427.89 in this item. That Materials and Supplies show so marked an increase is due to receipt, late in the fiscal year, of large quantities of car and track material, in anticipation of extensive renewal work in balance of the calendar year, and ties held for seasoning and treating at the tie treating plant.

In the grouping Deferred Debit Items a decrease of \$6,853,827.50 is shown in Special Deposits, being balance of proceeds of Equipment Certificates applied to the purchase of equipment during the year. The other items in this grouping represent sundry adjustments.

LIABILITIES.

The Liability side of the Balance Sheet discloses there has been no increase in total Capital Stock.

Mortgage, Bonded and Secured Debt—increased.....	\$21,791,546.39
explained as follows:	
First Mortgage Bonds .....	\$1,000,000.00
Issued under provisions of the mortgage in recoupment of construction expenditures.	
Convertible Debenture Bonds issued March 1, 1913.....	63,250,000.00
Issued to retire \$50,000,000.00 Three Year Gold Notes, and for other purposes.	
Collateral Notes issued June 30, 1913, due September 30, 1913 .....	6,250,000.00
(These notes were subsequently retired through the issue of One Year Notes due July 1, 1914.)	
Certificates of Interest, B. & O. Equipment Trust of 1913. Issued for the purchase of equipment.	1,000,000.00
Real Estate Mortgages and Ground Rent Liens on property acquired, capitalized .....	1,298,046.39
	\$72,798,046.39

Less: Following obligations matured and paid—	
Three Year Gold Notes matured June 1, 1913 .....	\$50,000,000.00
Certificates of Interest, B. & O. Equipment Trust of February, 1912, Series "A"....	1,000,000.00
Underlying Bonds acquired during the year .....	6,500.00
	51,006,500.00

Net increase in Mortgage, Bonded and Secured Debt.... \$21,791,546.39

As indicated above, there were issued on March 1, 1913, \$63,250,000.00 Twenty Year 4½ Per Cent. Convertible Gold Bonds, due March 1, 1933, convertible at the option of the holder at any time on or prior to February 28, 1923, at face value, into the Common Capital Stock of the Company, at the rate of \$110.00 per share of \$100.00 par value; the entire issue outstanding to be redeemable at the option of the Railroad Company on March 1, 1923, or any interest day thereafter, on proper notice, at 102½ per cent. of the face value thereof. For the purpose of this conversion your Board at its meeting held January 9, 1913, authorized the issuance of 575,000 shares of \$100.00 each, or \$57,500,000.00.

Under date of April 1, 1913, an equipment trust known as "Baltimore & Ohio Equipment Trust of 1913" was created. This trust amounts to \$10,000,000.00, payable in annual installments of \$1,000,000.00 each, and certificates of interest in this trust to the extent of \$1,000,000.00 were issued during the year; the balance will be disposed of during the ensuing year for the purchase of additional equipment now under contract.

ADDITIONS TO ROAD AND EQUIPMENT.

In continuation of the extensive programme for improvements followed for the last several years, large expenditures were made during the past year for Additions and Betterments, and also for Equipment.

Following will be found a statement showing the acquisition of new equipment during the year, which consisted of 54 locomotives, 2 passenger cars, 6,977 freight cars and 17 work cars, in addition to which 35 locomotives and 3,442 freight cars were rebuilt.

The capital expenditures for improvements during the year amounted to \$10,390,303.75.

ROAD.

At Baltimore, Md., a new transfer bridge, bulkhead and float were installed at Canton terminal for the more expeditious handling of freight between that place and Locust Point, also affording relief to the belt line tunnel.

Additional tracks, of 700 cars capacity, were laid in the classification yard at Curtis Bay, Md., and the large coal pier at this point was provided with more ample fire protection.

Several additional cross-overs were installed at Washington, D. C., with the necessary interlocking to protect the same. The wisdom of this expenditure was made apparent by the facility with which the Company was enabled to handle the vast number of people attending the recent inauguration.

The question of conserving the timber resources and the growing scarcity of ties has been given consideration, to the end that a modern tie and timber treating plant has been erected at Green Spring, W. Va., and it is anticipated that the prolongation of life of ties and timber, resultant from the preserving treatment afforded by this plant, will eventually result in substantial economies.

A third track has been completed between Green Spring, W. Va., and Patterson Creek, W. Va., a distance of 6.5 miles, and a fourth track completed between Hancock, W. Va., and Round Top, W. Va., a distance of 3.1 miles.

A new yard for interchange purposes has been constructed jointly with the Cumberland Valley R. R. Co., at Cumbo, W. Va., with all necessary attendant facilities. The average interchange at this point is 30,000 cars per month.

The low grade line between Rockwood, Pa., and Garrett, Pa., to provide an outlet for the increasing traffic of the Somerset coal fields, mentioned in the report of last year, has been completed.

The work of double tracking the Chicago Division has progressed as rapidly as circumstances would admit. During the year second track between the following points was completed, viz: Hamler, O., and Midway, O.; Mark Center, O., and The Bend, O.; and also Cromwell, Ind., and Milford Junction, Ind.

The new double track tunnel 4,000 feet in length, between Sand Patch, Pa., and Manila, Pa., has been completed, affording relief where urgently needed. The completion of this work gives a double track line between Philadelphia, Pa., and Chicago, Ill., with the exception of about 31 miles on the Chicago Division, which will be reduced to 23 miles when track is laid on grading just completed.

The work of converting from narrow to standard gauge, the line between Foxburg, Pa., and Mt. Jewett, Pa., about 93 miles, with attendant branches and sidings, has been completed.

New modern passenger and freight stations have been erected at Tunnelton, W. Va., and Salem, W. Va., and the stations at Lexington, Va., Piedmont, W. Va., and Zanesville, O., have been remodeled and enlarged. New freight facilities, embracing houses and tracks, were constructed at Cumberland, Md., and Youngstown, O.

During the year 17 new interlocking plants were built and 13 were reconstructed. Automatic signals were installed on 60.1 miles of double track and 5.4 miles of single track. In addition, line control block system was provided for 23.4 miles of track and a large number of safety devices were installed for protecting switches, grade crossings, etc.

The mileage of first track increased 1.27 miles, due to remeasurement; second track increased 26.52 miles, principally on the Chicago Division; third and fourth tracks increased 11.17 miles and 1.19 miles respectively, mainly on the Connellsville Division.

The following are some of the larger improvements now under way:

ADDITIONS TO TRACK AND BETTERMENT OF ROAD.

Work is now progressing on a new double track line and a relocation of parts of the old line between Little Cacapon, W. Va., and Orleans Road, W. Va., known as the Magnolia Cut-off. This improvement will connect the three-track line west from Little Cacapon and the three-track line east from Orleans Road, and when complete, will give a continuous three-track road all the way, and four tracks part of the way, between Patterson Creek and Cherry Run, a distance of 57 miles, where the density of traffic has already reached 20,000,000 ton miles per mile of road per annum, and is increasing rapidly. It will also effect a saving of 5.8 miles in distance and 877 degrees of curvature.

ADDITIONS TO TERMINAL FACILITIES.

There is now under construction at 26th Street and North River, New York City, N. Y., an eight story warehouse, which, when completed, will afford needed freight facilities at that point, and should enable the Company to materially increase its business.

RENEWAL OF BRIDGES AND ELIMINATION OF GRADE CROSSINGS.

Continued progress has been made in renewing bridges for use of heavier power.

The elimination of grade crossings in the cities of Baltimore, Md., Cincinnati, Ohio, and Chicago, Ill., has progressed steadily, in accordance with arrangements with these cities, and will, as previously stated in other reports, extend over a period of years.

**EQUIPMENT.**

Total Book Value of Equipment, June 30, 1912, was..... \$93,017,989.69  
During the year there were added to the equipment the following:

54 Locomotives, 2 Passenger Cars, 6,977 Freight Cars and 17 Work Cars, on which payments were made amounting to.....	\$8,008,027.18
And 35 Locomotives and 3,442 Freight Cars were reconstructed at a net cost of.....	884,747.77
	<u>8,892,774.95</u>
	\$101,910,764.64

During the year the following equipment was put out of service and credited to Property Investment—Equipment: 45 Locomotives, 8 Passenger Cars, 4,967 Freight Cars, 722 Work Cars and 1 piece of Floating Equipment, having a book value of..... 1,915,183.08

Making the Gross Book Value of Equipment.....	\$99,995,581.56
From this should be deducted:	
Accrued Depreciation on Equipment in Service, as follows—	
Amount at credit, June 30, 1912.....	\$10,812,860.96
Amount charged to Expenses for depreciation, year ended June 30, 1913.....	2,956,690.97
	<u>\$13,769,551.93</u>

Less: Charges to this account for depreciation accrued on equipment put out of service during the year..... 667,737.04

Balance to Credit of Accrued Depreciation on Equipment in Service, June 30, 1913..... 13,101,814.89

Leaving Net Value of Equipment, June 30, 1913..... \$86,893,766.67

The increased train load which has resulted from the improved road and use of heavier locomotives, has rendered necessary the retirement or thorough strengthening of certain classes of freight equipment. Where cars are of suitable capacity and in such condition generally to justify it, it is deemed economical to strengthen them with steel underframes and bolsters, and to apply friction draft gear. During the year 3,442 cars were so reconstructed.

Of the new equipment put in service during the year, 54 locomotives and 5,176 freight cars were acquired under the provisions of The Baltimore and Ohio Equipment Trust of February, 1912. The equipment contemplated by this trust has now all been delivered and consists of 60 steam locomotives, 2 electric motors, 24 steel passenger cars and 10,300 steel freight cars, costing \$11,119,693.79; 2,000 of the steel freight cars, however, are not included in the equipment account of The Baltimore and Ohio Railroad Company shown above, having been leased to The Sandy Valley and Elkhorn Railway Company by the Trustee of the trust.

There are also included in the above statement 1,792 steel freight cars acquired under The Baltimore and Ohio Equipment Trust of 1913. The following equipment is under contract for this particular trust and will be delivered during the coming fiscal year: 150 steam locomotives, 1 electric motor, 111 steel passenger cars and 2,030 steel freight cars.

**REVIEW OF ADDITIONS AND BETTERMENTS:**

All the more important work authorized by your Board in the four years since July 1, 1909, has been completed and placed in operation, with the exception of the Magnolia Cut-off hereinbefore referred to. In all, there have been constructed the following tracks, viz.: 1st main track, 16.54 miles; 2nd main track, 104.16 miles; 3rd main track, 46.83 miles; 4th main track, 10.83 miles, a total of 178.36 miles. There was also 21.19 miles of main tracks reconstructed on new locations. New double track tunnels were constructed at Kingwood, W. Va., and Sand Patch, Pa., replacing single track gauntlets at these summits; third tracks were extended on the heavier mountain grades and additional third and fourth tracks were placed on the line between Cumberland, Md., and Cherry Run, W. Va., where the greatest traffic density of the System is experienced. Forty-one new interlocking plants have been placed at various points and 17 plants have been reconstructed; and 193.3 miles of track have been automatically blocked at an average cost per mile of \$2,386.54. Yard, terminal, and station facilities have been enlarged and improved, and bridge and track conditions generally brought to greater capacity and higher standard.

As a result of this work, the line is now double track from Philadelphia, Pa., to Chicago, Ill., with the exception of about 31 miles on the Chicago division, which will shortly be reduced to 23 miles and which will be automatically locked and blocked in both directions. The line between Cumberland, Md., and Grafton, W. Va., is double tracked and where necessary on the heavier grades has three tracks. The line from Grafton, W. Va., to Parkersburg, W. Va., and thence to St. Louis, Mo., while mostly single track, is provided with ample sidings, principally lap, and so placed as to meet the reasonable requirements of the traffic on this line. Altogether, the line is believed to be in an efficient condition to care for present traffic and with the completion of the work authorized, to provide for considerable additional tonnage.

During the same period, that is, since July 1, 1909, 512 locomotives, 150 pieces of passenger equipment, and 27,438 freight cars (including 2,000 cars for the Sandy Valley & Elkhorn Railway Co.), with some additional work and floating equipment, have been acquired. In addition to this new equipment, 35 locomotives have been rebuilt and new and heavier frames were placed under 149 others. Three thousand nine hundred and forty-four freight cars (3,412 box cars and 532 gondolas) were rebuilt with steel underframes; 6,553 cars equipped with improved draft gear; 5,248 cars were equipped with cast steel truck bolsters, and 2,692 cars were equipped with cast steel body bolsters. The additional safety devices, prescribed by the Interstate Commerce Commission under Federal laws, have been applied as rapidly as the cars pass through the shops.

The relative capacity of engines and freight cars, 1913 over 1909, is shown as follows: Increased number of engines, 311, or 16.32 per cent.; total tractive power increased 20,592,299 pounds, or 35.18 per cent.; average tractive power increased 4,981 pounds, or 16.22 per cent. Increased number of freight cars (excluding cabooses cars) 9,647, or 11.92 per cent.; total increased capacity in tons, 809,046, or 27.46 per cent., average capacity increased 5 tons, or 13.89 per cent.

Incident to the acquisition of new cars and the reconstruction of others, the per cent. of all steel, steel underframe, and steel center sill cars to the total revenue freight equipment, at June 30, 1913, was 68.43 per cent., compared with 39.14 per cent. at June 30, 1909, placing the equipment as

a whole in a very much better condition to meet the present operating requirements.

The total expenditures for the period July 1, 1909, to June 30, 1913, for Additions and Betterments were \$42,002,908.32 and for Equipment \$41,512,207.33, a total of \$83,515,115.65.

A measure of justification for these large expenditures is reflected in the following tonnage and operating statistics:

In the fiscal year 1909 the Company moved 10,604,575,300 tons of Revenue and Company's freight one mile, with 23,477,078 freight train miles. In 1913 the tons moved were 15,032,723,403 tons one mile. Had the train load remained as in 1909 it would have required 33,280,326 freight train miles, whereas the freight train miles in 1913 were 23,098,811, a saving of 10,181,515 train miles. This has been accomplished by bringing the average train load, which was 451.70 tons in 1909, up to 650.81 tons in 1913.

That net operating earnings do not reflect more clearly these economies in operation, is due largely to the constantly increasing expense. Compared with 1909, increased rates of pay and changes in working conditions have added a charge of \$4,758,000 per annum; the cost of fuel, ties and other materials has increased; taxes have required an additional amount of \$841,806.79 and other increases have been brought about by legislation, Federal and State, and by the requirements for a higher standard of service, in all directions, than ever before.

**INDUSTRIAL DEPARTMENT.**

One hundred and seventy-two new industries, manufacturing and commercial, were located on or immediately adjacent to your line during the year, from which the Company should derive substantial freight revenues.

The President and Directors acknowledge the loyal and efficient services of the officers and employes during the past year, and particularly the energy, fidelity and skill displayed in overcoming the great difficulties incident to the flood of March, 1913.

By order of the Board,  
**DANIEL WILLARD,**  
President.

**CONDENSED INCOME ACCOUNT FOR YEAR.**

	1913.	INCREASE OR DECREASE.
GROSS EARNINGS, RAIL OPERATIONS.....	\$101,556,131.62	\$8,961,808.75 Inc.
TOTAL EXPENSES, RAIL OPERATIONS.....	73,779,637.98	9,070,100.39 Inc.
Net Earnings from Operation.....	\$27,776,493.64	\$108,291.64 Dec.
Percentage of Expenses to Earnings..	72.65	2.77 Inc.
OUTSIDE OPERATIONS.....	Def. \$874,310.91	\$207,670.92 Dec.
Total Net Revenue.....	\$26,902,182.73	\$315,962.56 Dec.
Railway Tax Accruals.....	2,960,905.09	177,710.22 Inc.
Operating Income.....	\$23,941,277.64	\$493,672.78 Dec.
OTHER INCOME.....	5,212,206.03	869,313.58 Inc.
Gross Corporate Income.....	\$29,153,483.67	\$375,640.80 Inc.
TOTAL DEDUCTIONS FROM INCOME: RENTS, INTEREST, HIRE OF EQUIPMENT, ETC....	15,819,232.98	939,448.52 Inc.
Net Corporate Income.....	\$13,334,250.69	\$563,807.72 Dec.
Net Corporate Income.....	\$13,334,250.69	
Dividend payments on Preferred Stock, 4%.....		2,354,891.36
Income Balance Transferred to Profit and Loss.....		\$10,979,359.33
Amount to Credit of Profit and Loss, June 30, 1912.....		\$40,754,430.99
Less Sundry Adjustments—Net Debit Balance.....	5,202,652.56	35,551,778.43
		<u>\$46,531,137.76</u>
Dividend Charges to Surplus, Common Stock 6%.....		9,120,975.68
Amount to Credit of Profit and Loss, June 30, 1913....		<u>\$37,410,162.08</u>

**CONDENSED GENERAL BALANCE SHEET FOR YEAR.**

ASSETS:	1913.	INCREASE OR DECREASE.
Total Property Investment.....	\$346,891,384.24	\$12,675,839.14 Inc.
Less: Accrued Depreciation on Equipment in Service.....	Cr. 13,101,814.89	Cr. 2,288,953.93 Inc.
Net Property Investment.....	\$333,789,569.35	\$10,386,885.21 Inc.
Total Securities: Proprietary, Affiliated and Controlled Companies....	217,171,444.64	31,691,895.86 Inc.
Total Other Investments.....	34,980,324.16	28,445,019.10 Dec.
Total Property and Other Investments	\$585,941,338.15	\$21,633,761.97 Inc.
Working Assets—Cash, Securities, etc,	54,813,626.40	7,366,737.64 Inc.
Deferred Debit Items.....	4,296,878.64	6,325,897.73 Dec.
Grand Total.....	\$645,051,843.19	\$22,674,601.88 Inc.
LIABILITIES:		
Common Stock.....	\$152,317,468.00	\$70,480.24 Inc.
Preferred Stock.....	60,000,000.00	10,753.50 Inc.
Stock Liability for Conversion of Outstanding Securities.....		81,233.74 Dec.
Total Stock Liability.....	\$212,317,468.00	
Total Funded Debt.....	365,674,325.71	\$21,791,546.39 Inc.
Total Capital Liabilities.....	\$577,991,793.71	\$21,791,546.39 Inc.
Working Liabilities.....	14,870,687.72	2,779,310.62 Inc.
Accrued Liabilities not Due.....	8,251,602.12	765,149.13 Inc.
Deferred Credit Items.....	3,789,547.00	506,535.57 Inc.
SURPLUS:		
Additions to Property through Income since June 30, 1907.....	1,227,739.06	
Invested in Other Reserve Funds..	1,503,291.50	176,329.08 Inc.
Profit and Loss Balance.....	*37,410,162.08	3,344,268.91 Dec.
Grand Total.....	\$645,051,843.19	\$22,674,601.88 Inc.

\*Including \$10,965,168.91 Additions to Property through Income prior to June 30, 1907.

# Railway Age Gazette

PUBLISHED EVERY FRIDAY AND DAILY EIGHT TIMES IN JUNE, BY THE SIMMONS-BOARDMAN PUBLISHING COMPANY, WOOLWORTH BUILDING, NEW YORK.

CHICAGO: Transportation Bldg. CLEVELAND: Citizens' Bldg.  
LONDON: Queen Anne's Chambers, Westminster.

E. A. SIMMONS, *President*.  
L. B. SHERMAN, *Vice-President*. HENRY LEE, *Sec'y & Treas.*  
The address of the company is the address of the officers.

### EDITORS.

SAMUEL O. DUNN, *Editor*.

ROY V. WRIGHT, <i>Managing Editor</i> .	H. H. SIMMONS	E. S. FAUST
W. E. HOOPER	H. F. LANE	F. W. KRARGER
B. B. ADAMS	E. A. AVERILL	A. D. CLOUD
E. T. HOWSON	R. E. THAYER	GEORGE L. FOWLER
	A. C. LOUDON	

Subscriptions, including 52 regular weekly issues and special daily editions published from time to time in New York, or in places other than New York, payable in advance and postage free:

United States and Mexico.....	\$5.00
Canada .....	6.00
Foreign Countries (excepting daily editions).....	8.00
Single Copies .....	15 cents each

Engineering and Maintenance of Way Edition and four Maintenance of Way Convention Daily issues, North America, \$1.00; foreign, \$2.00.

Entered at the Post Office at New York, N. Y., as mail matter of the second class.

WE GUARANTEE, that of this issue 8,200 copies were printed; that of those 8,200 copies, 6,641 were mailed to regular paid subscribers and 848 were provided for counter and news companies' sales; that the total copies printed this year to date were 422,759—an average of 8,648 copies a week.

VOLUME 55. DECEMBER 5, 1913. NUMBER 23.

## CONTENTS

### EDITORIAL:

Editorial Notes .....	1053
British Commission to Study Nationalization.....	1054
Coupler and Draft Sill Repairs .....	1055
*Seaboard Air Line .....	1056, 1102
Missouri, Kansas & Texas.....	1057, 1104
*Colorado & Southern.....	1058, 1101
New Books .....	1059

### LETTERS TO THE EDITOR:

The Overlap .....	1060
-------------------	------

### MISCELLANEOUS:

*Studies in Operation—The Chesapeake & Ohio.....	1061
The Railway Employee and the Railway Patron; by Samuel O. Dunn .....	1065
*Summit-Hallstead Cut-Off of D. L. & W.....	1069
*Inside Sheathed Steel Frame Box Cars; by R. W. Burnett.....	1075
*Future Development of Chicago Terminals .....	1078
Steel Underframe Box Cars; by George W. Rink.....	1081
Seams in Rails .....	1082
*Fairfax Harrison .....	1084
Foreign Railway Notes .....	1060, 1065, 1068, 1074, 1077, 1083
GENERAL NEWS SECTION .....	1085

\*Illustrated.

THE study of operation on the Chesapeake & Ohio, the results of which are printed elsewhere in this issue, was undertaken without any idea that it might be particularly pertinent at this time to the question before the Interstate Commerce Commission. As a matter of fact the preliminary work of getting together figures was begun more than six months ago. The results, however, have a striking bearing directly on this inquiry. The Chesapeake & Ohio is in fine physical condition. The very fact that it had to do a lot of work to repair flood damage was taken advantage of to put roadway in thoroughly good condition, although the work was rather delayed. There is no congestion east of Cincinnati, and yet the C. & O. coal operators are suffering from "the inadequacy of railroad facil-

ities"; in other words, the lack of railroad credit. Railroad credit depends on net earnings, not on gross; and, as in the case of the Chesapeake & Ohio, net may be abnormally reduced on a particular road, even when that particular road's facilities are ample, because of the lack of facilities on other roads.

NO movement in recent years has attracted the attention of railway engineers so generally as the valuation of railway properties now being undertaken by the government, and the response to the call of the Civil Service Commission for applicants for positions was most unusual both in the number and in the high standing of the men it drew out. Now that the preliminary grades have been announced and the Board of Engineers is engaged in the selection of men preparatory to making appointments, there is much discussion of the relative advantages and disadvantages of affiliation with this gigantic enterprise. The work has much to attract the railway engineer; and the government Board of Engineers will undoubtedly draw very heavily upon railway engineers in organizing its forces for men without the railway experience will be seriously handicapped. The problem is without precedent either in form or magnitude. The work is for the public, which will appeal to the sense of duty and public spirit of many. The experience gained will be valuable in a field certain to expand rapidly in the near future. The opportunity for a study of conditions on a number of roads as well as for gaining a wider acquaintance among railway and government officials, are also advantages. On the other hand, the engineer who is offered a position with this board may well stop to consider some of the obvious disadvantages. In the first place, while nearly all the applicants desire to secure the \$4,800 positions, the number of positions paying this salary will be relatively small. In fact, it is understood that the Board of Engineers is now interrogating many applicants regarding the minimum amount they will accept. Another important objection is the uncertain tenure of position. While the work was originally intended to extend over five years, and if carried to completion will undoubtedly require considerably more time, the carrying out of the project is entirely dependent upon the will of Congress. It is generally believed by railway men that the valuation, if properly conducted, will in most cases show the values of the properties to be greater than capitalizations. In view of the general public impression to the contrary, the demand for valuation may diminish perceptibly if the first reports completed should show high valuations. It would be no unheard of thing under these conditions for Congress to fail to appropriate funds for continuing the work. The recollection of similar action regarding the Commerce Court is still fresh in mind. The similar discontinuance of valuation work in Kansas after a large part of the data had been collected is another case in point. Such a procedure is, of course, not anticipated at this time, but it is one of the possibilities which men considering such positions must bear in mind.

THE correspondence between a member of the Illinois legislature and the general counsel of the Chicago, Burlington & Quincy, discovered by the Interstate Commerce Commission in its general investigation of the pass situation, as reported in our news columns, in which the road was threatened with legislative retaliation because of its refusal to issue free transportation, forms an illuminating example of some of the difficulties encountered by the railways in their efforts to improve the conditions which have led to the public demand for regulation. State Senator Denvir has denied that he wrote the requests for transportation or the threat referred to and has sought to evade responsibility by calling the letters forgeries or a joke by some of his friends, although he has not explained how letters addressed to him at his home have fallen into the hands of the jokers, who wrote over his signature "when our committee gets through with you, you will find your road in the hands of a



receiver." However, whether or not Senator Denvir was the author of the letters, most railway men know that they are a fair sample of methods very frequently resorted to by public officials to hold up the railways for favors or more valuable considerations. Other roads have equally interesting collections of letters from politicians, which will doubtless be discovered by the commission in its investigation. It is not quite the usual thing for such threats to be expressed in letters, but similar verbal threats are not at all uncommon. A railway pass no longer possesses much purchasing power, but the refusal of a pass still involves possibilities of a great deal of trouble, and there have been very strong reasons for the failure of the roads to abolish state passes at the time interstate free transportation was made illegal. Moreover, there are still many legislators and other public officials who are not satisfied with passes, and who have frequently made it very expensive for railways to refuse their demands. It has been popular to place the blame for the corrupt relations that formerly prevailed between the corporations and the politicians on the corporations alone, ignoring the fact that for every bribe that was ever given there was some one to receive it, if he did not actually solicit or demand it. The public finally tried to remedy the situation by regulating the railways, but it has thus far made the mistake of leaving most of the power to regulate in the hands of the same men who previously, as legislators, had been practicing the gentle arts of bribetaking and blackmailing. This fact has been responsible for far more of the anti-railway legislation of recent years than most people realize. The railways have been obliged to clean house, and they have tried to proceed on the theory that "honesty is the best policy," but the people who tried to reform the railways have neglected to clean house themselves and have continued to elect to public office and to their law-making bodies the same kind of grafters and blackmailers that have been at least halfway responsible for the evils that the people were trying to eliminate. It is time the public realized that corrupt relations between business and politics are two sided, and therefore cannot be abolished by attacks on one side only.

ON the Montana division of the Northern Pacific, the use of Form 31 for train orders has been entirely abandoned, except in cases where the superiority of the train addressed is restricted at the point where the order is delivered. This almost exclusive use of Form 19 has now been in effect for several months, and with marked satisfaction. That the movement of trains has been much facilitated goes without saying. On those portions of the road (single track) where the trains have the additional protection of automatic block signals, Form 19 is used even to restrict rights at the meeting point, Rule 211 requiring that, in such a case, the operator shall stop the train before delivering the order. The only difference between Form 31 and Form 19 is that Form 31 must be acknowledged in writing by the conductor or engineman or both. The order cannot be acted on until the despatcher knows this. Getting signatures makes much delay. Many despatchers are firmly convinced that equal or greater safety can be secured without requiring signatures. In the interest of this view we are glad to reprint on another page, an editorial from the last issue of the *Train Despatchers' Bulletin*. The reader will recall that this subject was discussed at some length in the *Railway Age Gazette* last year.\* The principal obstacle to complete agreement on the exclusive use of Form 19 appears to be the objection raised by Mr. Fay, of the Sunset-Central Lines, set forth in our issue of April 5, just referred to. This in substance is that the rule forbidding the giving of a restricting order at the point where the restriction takes effect is not a sufficient safeguard. Suppose that by time table schedules two trains are to meet at C. To hold the superior train there for the inferior train the despatcher, desiring to use Form 19, may not send the order to C, but may send it to the last pre-

ceding station B. This is on the assumption that the engineman will read the order after leaving B and before reaching C. But the distance and time may be so short that he cannot be depended on to do this invariably. But is not this condition readily met by having a third form, one requiring the train to be stopped but not requiring signatures? Or, with proper regulations, the three kinds of order can be regularly employed without having three (or even two) colors of blanks. Are we not in danger of elevating our forms to the dignity of a fetish? The "middle order"—sending meeting orders always to the operator at the appointed meeting place—is an important safeguard under any scheme of order forms. The most pervasive weakness of our train despatching is the spirit that puts up with partial adherence to standards which have been accepted as essential to a complete system. If the middle order is essential why do we not insist on it everywhere? If automatic signals make signatures or the middle order unnecessary why should they not also make written orders unnecessary, and thus save still more time? This, and other questions, not touched upon here, ought to be thrashed out and settled. All of the foregoing is, of course, addressed to those who have no block system (or who have one and do not dare to depend on it).

#### BRITISH COMMISSION TO STUDY NATIONALIZATION.

THE growing interest in the subject of railway nationalization is strikingly illustrated by the recent appointment in Great Britain of a royal commission to inquire into the relationship between the railway companies and the state "in respect of matters other than the safety of working and conditions of employment," and to report what changes, if any, in that relationship are desirable. The announcement comes almost simultaneously with that of the National Civic Federation in this country of its intention to undertake a national survey of social progress which will include a study of the question whether regulation of railways and other public service corporations is a failure, and whether state ownership should be substituted for that of private capital.

While the investigation of the British Commission is not to be confined solely to the question of nationalization, it is well understood that inquiry regarding that subject is its essential purpose. It therefore appears somewhat strange that the terms of reference should have so explicitly excluded safety of working and conditions of employment. In this country, until recently, most of the discussion of government ownership or operation of railways has originated with those who have professed to see in it a means of both increasing safety and improving working conditions, and it would seem that no serious and thorough consideration of the general question could ignore these matters. On the one hand, the muckrakers have manipulated statistics to convince uninformed readers that government railways abroad are uniformly safer than the privately owned lines of this country; and on the other hand, the socialists and near-socialists have deluded themselves into believing that the creation of 1,700,000 additional government jobs would herald the approach of the millennium for the working man. That railway nationalization would have a most vital effect on these two important phases of the transportation problem is beyond dispute, although the effect would probably not be a beneficial one. In fact, the demands of the labor unions have played a prominent part in the agitation of the subject in Great Britain.

A more impelling cause for the appointment of the royal commission, however, undoubtedly lies in the change in the financial condition of the British railways, which corresponds somewhat to recent changes in this country. It is notable that of late much of the more serious suggestion of the possibility of nationalization in this country has originated with railway men, inspired rather by fear that the government will soon have to relieve the private owners of a responsibility they may no longer care to bear for the reward offered, than by any opinion that such a step would be wise. This change in the character of the discussion

\*March 8, 15, 22; April 5; June 7.

has come about from the economic condition into which the railways have been brought by a regulation of income downward, accompanied by, but disassociated from, a separate regulation of expenses upward under another set of laws. It is possible that the overshadowing financial aspect of the situation in Great Britain has been responsible for the exclusion from investigation of secondary features of the problem.

The make-up of the new royal commission is characteristically British. All of the members have held positions of responsibility and prominence in the business world or in public service, and have thus gained experience that might be expected to develop the kind of judgment required to decide such an intricate and weighty problem on its merits.

The chairman, the Earl of Loreburn, is a former Lord chancellor who was decorated for services in connection with the Venezuelan boundary arbitration. The other members include the Earl of Derby, formerly financial secretary to the War Office and postmaster general; Sir Henry Primrose, formerly chairman of the Board of Inland Revenue and chairman of the Board of Customs; F. Huth Jackson, late president of the Institute of Bankers; Sir F. R. Upcott, who has been consulting engineer to the Madras government railways, government director of Indian railways and chairman of the board of the Indian railways; Sir W. Plender, president of the Institute of Chartered Accountants and auditor to numerous railways in England; A. Balfour, managing director of Seebohm & Dieckstahl; R. E. Prothero, for several years editor of the *Quarterly Review*; and D. J. Shackleton, senior labor adviser to the Home office.

The railway press of England comments on the fact that the only practical railway man on the commission has gained his experience on the Indian railways, and that there is no representative of British railway methods; but confidence is expressed that the companies will be able to prove to the commission that the advantages of private ownership outweigh any benefits that might be derived from state ownership, and that the cost of purchasing the lines on fair terms would substantially exceed their large capitalization. A royal commission on railways appointed in 1865 reported two years later against the exercise by the state of its powers to purchase the railways.

#### COUPLER AND DRAFT SILL REPAIRS.

THE complaint is often made that there is a much more rapid deterioration of railway rolling stock than there was a few years ago. Frequently, the cause is laid to defective material, but usually someone calls attention to the greater service and, incidentally, the severer stresses to which the present day car is subjected. It is, of course, the freight car that comes in for the greater part of this attention, and there can be no doubt that the damages inflicted upon it are very much greater than they were a few years ago, a statement that will be substantiated by an examination of the repair records of any railway.

One master car builder attributes this to four fundamental causes: the rapid introduction of heavy locomotives; the promotion of large numbers of firemen, inexperienced in locomotive handling, to the position of engineers; the use of heavier and stronger cars interspersed through a train of weaker and lighter ones; and the work of handling a dense traffic in heavy trains on single track, where much sawing to and fro has to be done at passing sidings. Any one of these causes would have an appreciable effect on car repairs, especially in such matters as broken drawbars and sills, but, when they are all combined, the cumulative result is one at which railway officers may well stand aghast.

Take the single item, perhaps as large as any, of couplers broken or pulled out. Four years ago this was not as serious as it is today. At that time on an ordinary road where the car mileage would run from 6,000,000 to 8,000,000 a month, the number of broken couplers would range from 25 to 100 in the same time; but these records showed a sudden and substantial rise

about two years ago when locomotive weights took a leap ahead and traffic demands required the promotion of large numbers of men. The repair sheets now show from two to five times the number of broken or pulled out couplers. It would hardly be possible that any one of the four reasons given could be responsible for the whole increase, but each has contributed its quota to swell the figures to their present formidable proportions.

Strange to say the number of wheels used has, apparently, not been appreciably influenced by the causes that have had such a disastrous effect on couplers and sills. Records of some of the northern roads show that the number of wheels replaced has increased on the average in about the same ratio as the wheel mileage, with a regular annual spasmodic increase for the later winter months of February and March, due to the pounding action on a hard and unyielding roadbed that has been solidified by the frost. This indicates that the cast iron wheel is, at least, holding its own in the fight against the greater stresses to which it is subjected. But it will be noticed that not one of the four causes of destruction cited, that have such serious effects upon couplers and sills, has any effect whatever upon the wheels, with the single exception perhaps of the promotion of inexperienced men, and then only as they are affected by the application of the brakes.

What are the possibilities of decreasing this chronic destructiveness? It is probable that the records of car equipment on most roads will show a gradual elimination of the old cars of 20 tons capacity, so that in a year or so more they will have entirely disappeared. As for the 30-ton capacity cars, their numbers are too great to expect their immediate disappearance, but in some places when the center sills on the old cars are broken they are replaced by steel sills with the couplers and draft rigging attached as substantially as in all-steel cars, so that the practical elimination of the factor of weakness as indicated by use of strong and heavy cars in a train of light ones will disappear as a contributing element of destructiveness long before the 30-ton car will have itself ceased to figure on the equipment roll, if, indeed, that time ever comes; though, with the introduction of the heavier capacity cars, the actual number of 30-ton cars is decidedly on the decrease on some roads.

As for the 40-ton and 50-ton cars, their increase has been and still continues by leaps and bounds. Some roads are maintaining a nearly constant quantity of the one, while all new equipment is of the other. In these cars the weakness of the wooden underframing has disappeared and steel has taken its place either for the underframing alone or for the whole structure of the car. When this steel construction has replaced the old wooden construction to such an extent that it can be regarded as universal, then the third of the four elements will be done away with.

Whether the car can be made strong enough to withstand the normal stresses applied by the continually increasing locomotive power is a question that will undoubtedly be answered in the affirmative. It may involve the construction of heavier cars, but the strength to resist ordinary traction stresses will be found in the future, as it has been in the past, and experience and discipline, it is hoped, will make the engineer more careful in the handling of the train.

While the last item can probably never be entirely blotted out on a single-track line where stops and starts at passing sidings must be frequent, it can and will be greatly modified in its effects by the use of longer sidings and the obviating of much of the work that must now be done. It would, perhaps be too optimistic to expect that repair costs will ever drop back to the old figures of five or six years ago, but it seems more than probable that, when the general run of rolling stock has been adapted to the new conditions under which it must operate, the freight car repair bill will be reduced from its present proportions and take on an aspect that we have been in the habit of considering normal.



The Seaboard is using Pacific type locomotives in its freight service. Out of the total 252 locomotives in freight service (owned at the end of 1913) 168 were 10-wheel and Pacific type locomotives, and since June 30 the Seaboard has added 35 Pacific type locomotives to its freight service.

It will be noted that the saving made in expenses in 1913 as compared with 1912 was in maintenance. Maintenance of way and structures cost \$3,015,000 in 1913, a decrease of \$332,000. Maintenance of equipment cost \$3,239,000, an increase of \$126,000. More than half of the decrease in maintenance of way expenses was in the single item bridges, trestles and culverts. In 1912 \$502,000 was spent on this account, and in 1913 \$346,000. The Seaboard has just completed a program of bridge renewals, and all bridges on main line are now Cooper E50, and while, of course, the additional cost of replacing an old structure with a modern one is charged to property account, the cost to replacement in kind is a charge to expenses, and this cost in 1912 and for two or three years previous was abnormally high. Maintenance of way, of course, does not vary in cost in proportion to changes in traffic and with a larger business carried maintenance of way charges would naturally show a smaller proportion of gross consumed by this account. The Seaboard Air Line was better maintained last year than it was the year before. The new management has had time to study carefully the needs of the property and the saving made, over and above the smaller sums spent for bridges, was the result rather of a cutting out of unnecessary expenditures than the reduction of any work that was necessary to the upkeep of the property.

It is almost universal now for railroad managements to make a definite appropriation by months or for longer periods for both maintenance of way and maintenance of equipment. Until recently, however, the practice of the Seaboard Air Line in this respect was rather indefinite and the maintenance force and motive power officers were not held very strictly to any definite appropriation. Last year, however, the Seaboard followed the practice now generally accepted as best of making maintenance expenditures conform strictly to a carefully thought out and generally adopted program. The maintenance of way expenditures in 1913 were at the rate of \$981 per mile of road.

A detailed comparison of the Seaboard's maintenance charges with those of the Atlantic Coast Line and the Southern Railway per mile of road apparently indicates higher labor charges and lower costs for material. If the Seaboard was really stinting on its appropriations for ties and rails it would be a very poor sort of economy shown in the lower maintenance charges. As a matter of fact, however, the explanation seems to be that the Seaboard is getting its material more cheaply than is the Southern or the Atlantic Coast Line or else there is some difference in accounting methods as to what is charged to betterment and what to maintenance.

Repairs, renewals and depreciation per locomotive amounted to \$2,557; per passenger car to \$809, and per freight car to \$60.

During the year the company spent a total of \$3,659,000 for betterments and additional equipment. Of this amount \$1,727,000 was spent for additions to the roadway and structures, and \$1,932,000 for equipment. The largest expenditures for construction was \$286,000 for storage warehouses, \$218,000 for heavier rails, and \$177,000 for station buildings and fixtures. It is interesting to note that the Seaboard now has 1,374 miles of telephone train despatch circuits in operation, 285 miles having been added last year.

The Seaboard Air Line operates 3,074 miles of road. The freight density in 1913 was 500,539, an increase over 1912 of 45,768. The passenger density was 77,247, an increase of 1,657. The average ton-mile rate in 1913 was 1.09 cents, and in 1912 1.11 cents. The revenue per freight train mile was \$2.68 in 1913, and \$2.63 in 1912. The average haul of freight was 148 miles, and the average passenger journey 42 miles. There was almost no change from 1912 to 1913 in these figures.

The Seaboard was in a very much stronger position as regards

current assets at the end of the year than at the beginning. During the year \$800,000 four per cent. refunding bonds were sold and \$5,000,000 three year five per cent. notes, the total authorized issue of these notes is \$6,000,000. On June 30, 1913, there was on hand \$4,512,494 cash, no loans or bills payable, and total working liabilities of \$2,893,000.

The following table shows the principal figures for operation in 1913, compared with 1912:

	1913.	1912.
Average mileage operated .....	3,074	3,059
Freight revenue .....	\$16,788,112	\$15,433,239
Passenger revenue .....	5,221,200	5,050,068
Total operating revenue .....	24,527,865	22,921,904
Maint. of way and structures.....	3,014,957	3,347,359
Maint. of equipment .....	3,338,542	3,212,278
Traffic expenses .....	765,763	715,361
Transportation expenses .....	8,899,267	8,333,358
Total operating expenses.....	16,725,613	16,280,087
Taxes .....	956,000	917,000
Operating income .....	6,819,938	5,702,131
Gross income .....	7,040,002	5,885,509
Net income .....	2,985,854	2,063,444
Interest on income bonds.....	1,250,000	1,249,658
Surplus .....	1,735,854	813,786

MISSOURI, KANSAS & TEXAS.

EVEN making full allowance for the fact that in comparing 1913 with 1912 on the Missouri, Kansas & Texas the former year was a particularly unfavorable one, the showing made in the fiscal year ended June 30, 1913 is remarkably good. For a number of years the ratio of transportation expenses to total operating expenses has been in the neighborhood of 40 per cent. In 1913 the ratio was 37.90 per cent., comparing with 41.32 per cent. in 1912 and 39.25 per cent. in 1911. Both passenger and freight revenue increased very largely in 1913 over 1912 as a result of a 1.7 per cent. increase in the tons of freight carried, and an increase of 7.4 per cent. in the average length of haul of freight, and an increase of 5.6 per cent. in the revenue per ton per mile; and an increase of 9.6 per cent. in the number of passengers carried, and of 4.8 per cent. in the average passenger journey. The revenue per passenger per mile was slightly less in 1913 than in 1912. The increase in revenue per ton per mile was, of course, due to changes in the character of traffic carried.

In 1913 the Missouri, Kansas & Texas earned gross \$32,346,000, an increase over 1912 of \$4,160,000, or 15 per cent. Expenses increased but 8 per cent. With an increase in credit balance of hire of equipment just about offsetting increases in interest charges, the company had net available for dividends in 1913 \$2,317,000, while in 1912 the company barely earned its interest charges. After the payment of 4 per cent. on the preferred stock, there was a surplus in 1913 of \$1,796,000, which is equivalent to 2.84 per cent. on the outstanding common stock, which was, however, invested in the property.

The much lower ratio of transportation expenses to revenues in 1913 than in 1912 has already been commented on. The ratio of maintenance of way to revenue in 1913 was 14.33, as against 14.65 in 1912, and of maintenance of equipment 12.68, as against 13.29. The relative reduction in transportation expenses is due in the first place to better supervision, and in the second place to much improved operating conditions. There was a reduction of \$146,000 in the cost to the company of injuries to persons, leaving, however, the very large amount of \$659,000 paid out on this account even in 1913. The utterly unfair attitude which juries and public opinion in the Southwest take in regard to employees' suits for injuries has been commented on at length in these columns. The improvement shown in this account may be, and it is to be hoped that it is, in part the result of changing sentiment in regard to railroads, especially in Texas; but it is also in good part due to the efforts of the management to do everything in its power to reduce the possibility of such suits. As an example of these efforts, the company is spending considerable sums of money to equip freight cars with handholds, which are not only not liable to become loosened accidentally, but cannot readily be tampered with.

Since the greater part of the added freight revenue was due to a longer average haul, it was to be expected that a com-

parative saving could be made in many items of transportation expenses. This saving was helped by a slightly increased revenue train load and somewhat larger increased total train load, the revenue train load being 243 tons in 1913 and 241 tons in 1912, and the total train load being 287 tons in 1913 and 273 tons in 1912. The improvement in train loading was due almost entirely to a smaller percentage of empty car mileage. This percentage in 1913 was 35.58 per cent., and in 1912, 37.67 per cent. Car loading of revenue freight was not quite so good in 1913 as in 1912, the average per loaded car being 14.60 tons last year and 14.93 tons the year before, and the total number of cars per freight train remained almost exactly the same, namely, slightly less than 26.

There is an opportunity for a very materially larger average revenue train load on the M. K. & T. as a whole, and the lines in Texas have already shown a considerable improvement. During the latter part of the last fiscal year 40 mikado locomotives were added to freight service, and the use of these heavier engines in itself ought to increase the average train load. The M. K. & T. traffic is for most of the year an unbalanced traffic, and the company labors under a disadvantage as compared with the St. Louis & San Francisco in having no slow haul freight traffic northbound. In 1913 the Beaumont & Great Northern, which runs through the lumber district of east Texas and connects with the Trinity division (orphan line) of the Missouri, Kansas & Texas, was acquired, and in the near future some sort of a connection will be formed between this line and the main line of the Katy. This should supply the much needed northbound drag freight which will go far toward bringing up the average revenue train load.

Very extensive betterment work is in progress on the Missouri, Kansas & Texas; and by "extensive" is not meant some large spectacular line revision, but a general policy of bringing the whole property up to a higher standard. In 1913 a total of \$2,455,000 was spent for additions and betterments to the property, exclusive of equipment, and of this amount \$230,000 was for increased weight of rail, \$402,000 for terminal yards, \$204,000 for ballast, and \$154,000 for station buildings and fixtures. Four hundred and fifty wooden trestles and culverts were renewed with concrete structures, and steel bridges were built on the Fort Worth, the Houston and the San Antonio divisions, and on the Texas Central, replacing pile trestles. All of the bridges north of the Red river on the main line have now been strengthened to permit of the operation of the mikado locomotives, and a program of bridge strengthening is being carried on on the lines in Texas.

The net expenditure for additional equipment for the year was \$1,507,000.

During the year the company sold \$19,000,000 2-year 5 per cent. notes, retiring \$16,000,000 2-year 5 per cent. notes. The company also sold \$1,900,000 5 per cent. equipment certificates. At the end of the year there was on hand \$1,503,000 cash included in total working assets of \$8,442,000, against which there were working liabilities of \$7,362,000, which included \$1,516,000 loans and bills payable, of which \$800,000 were paid off to November 1, 1913.

The following table shows the principal figures for operation in 1913 and 1912:

	1913.	1912.
Average mileage operated.....	3,677	3,398
Freight revenue.....	\$20,912,978	\$18,100,906
Passenger revenue.....	9,402,967	8,220,409
Total operating revenues.....	32,346,258	28,186,719
Maintenance of way and structures.....	4,637,748	4,129,256
Maintenance of equipment.....	4,100,819	3,745,233
Traffic expenses.....	755,120	738,928
Transportation expenses.....	12,255,845	11,647,573
General expenses.....	1,058,880	944,859
Total operating expenses.....	22,808,412	21,205,849
Taxes.....	1,287,903	1,060,181
Operating income.....	8,249,943	5,920,689
Gross income.....	8,916,554	6,277,085
Net income.....	2,316,985	17,168
Dividends.....	521,052	521,635
Surplus.....	1,795,933	*504,467
*Deficit.		

COLORADO & SOUTHERN.

THE Colorado & Southern operates 1,850 miles of road, all of which is single track with the exception of about three miles, and has 527 miles of yard tracks and sidings. The road performs two important services. It is an outlet for Colorado products to the gulf, forming part of a rail and water route to Atlantic seaboard markets, and a route for northbound winter fruit and vegetable shipments, and secondly, it taps the rich mining and bituminous coal fields of Colorado.

In 1913 the total tonnage of freight carried on the C. & S. was 7,453,000 tons, earning \$10,836,000 revenue, and of the tonnage, 66.89 per cent. originated on the C. & S. lines and the remaining 33.11 per cent. on other roads. Bituminous coal furnished in 1913 29.39 per cent. of the total tonnage and 24.93 per cent. of the total revenue, and products of mines, including coal, furnished 62.66 per cent. of the tonnage and 44.16 per cent. of the revenue. Next in importance, both as to tonnage and revenue, is products of agriculture, which in 1913 furnished 16.04 per cent. of the tonnage and 20.81 per cent. of the revenue. Manufactures furnished 9.07 per cent. of the tonnage and 12.49 per cent. of the revenue. The principal change in the character of traffic in 1913 as compared with 1912 was a large increase in the tonnage and revenue from products of agriculture. This tonnage in 1912 was 944,000, and in 1913, 1,196,000; and the revenue in 1912 was \$1,874,000, and in 1913, \$2,255,000. There was a decrease in tonnage but a slight increase in revenue of products of mines, the tonnage of these commodities in 1912 being 4,772,000, and in 1913, 4,670,000, and the revenue in 1912, \$4,747,000, and in 1913, \$4,785,000.

The fiscal year ended June 30, 1913, was a profitable one for the C. & S. Its operating revenues amounted to \$15,078,000, an increase of \$1,118,000; and while expenses totaled \$10,623,000, an increase of \$1,007,000, the principal part of the increase came in maintenance expenditures, and transportation expenses amounted to \$4,901,000 in 1913, as against \$4,729,000 in 1912. The following table shows the percentage of operating revenues consumed by each of the five classes of expenses:

	1913.	1912.
Maintenance of way and structures.....	12.64	11.73
Maintenance of equipment.....	20.64	18.14
Traffic expenses.....	1.53	1.69
Transportation expenses.....	32.50	33.87
General expenses.....	3.14	3.45

After the payment of interest, rentals, etc., the company had available for dividends \$1,665,000 in 1913 as against \$1,500,000 in 1912.

Some of the reasons why it was possible to make such a considerably better showing in transportation expenses in 1913 than in 1912 are probably to be found in changes in operating conditions, of which changes it is evident that the management took full advantage. The number of passengers carried decreased by 263,000, the total in 1913 being 2,919,000; but the average passenger journey increased from 41 miles to 46 miles, the earnings per passenger per mile being 2.56 cents in 1913 and 2.52 cents in 1912. Thus, with a decrease in the number of passengers there was an increase in the number of passenger miles and a slight increase in the compensation per passenger per mile and the change in number of passengers and length of haul made it possible to decrease passenger locomotive mileage from 3,092,000 in 1912 to 2,817,000 in 1913. The tonnage of freight was 7,453,000 in 1913 and 7,148,000 in 1912. The average haul was 154 miles in 1913 and 148 miles in 1912, and the ton mileage rate, 9.44 mills in 1913 and 9.31 mills in 1912. Freight locomotive mileage increased by 180,000 miles, totaling 3,740,000 in 1913, and the total freight car mileage increased by 6,219,000, totaling 84,495,000 in 1913. But the greater part of this increase came in loaded mileage, which in 1913 totaled 55,373,000, an increase of over 5,000,000, while empty car mileage totaled 25,785,000 in 1913, which is an increase of less than 1,000,000 car miles.

It would appear from this and from a study of the changes

in the character of commodities carried that the Colorado & Southern is building up its through service both for freight and passengers, and is successful in getting a larger share of fruit and vegetable traffic from Colorado to gulf ports and eastern markets, and winter vegetable movement to Colorado, and that the short haul coal business, last year at least, fell off somewhat.

from 2 per cent., calling for \$620,000 dividends, to 1 per cent., calling for \$310,000.

The following table shows the principal figures for operation in 1913 and 1912:

	1913.	1912.
Average mileage operated.....	1,850	1,881
Freight revenue .....	\$10,836,134	\$9,850,049
Passenger revenue .....	3,394,074	3,246,773
Total operating revenues.....	15,077,677	13,959,976
Maintenance of way and structures....	1,905,988	1,637,316
Maintenance of equipment.....	3,111,513	2,532,181
Traffic expenses .....	230,407	236,127
Transportation expenses .....	4,901,494	4,728,765
General expenses .....	473,560	482,066
Total operating expenses.....	10,622,962	9,616,454
Taxes .....	520,547	511,470
Operating income .....	3,909,364	3,807,529
Gross income .....	4,753,642	4,597,802
Net income .....	1,665,313	1,499,968
Dividends .....	990,237	1,300,000
Surplus .....	675,076	199,968

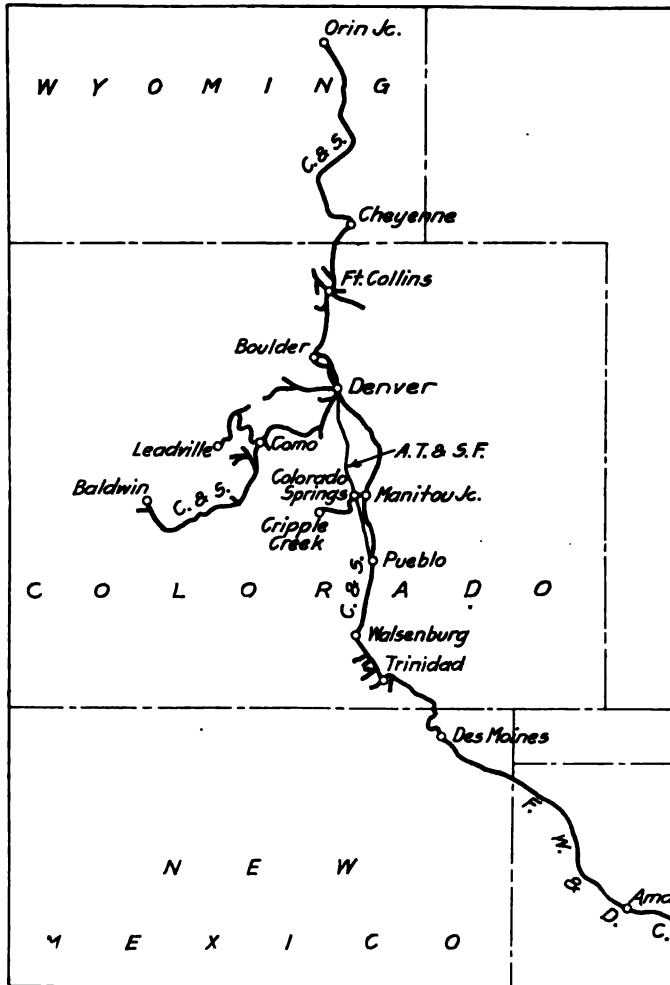

The Colorado & Southern.

Under these circumstances an increase in the average train load (standard gage) of from 327 tons to 332 tons is a far more creditable achievement than would appear on the face of it. Like other roads, however, in both the east and west the Colorado & Southern is seriously feeling the effects of increased train crew wages and changed working conditions. The operating expenses per total train mile in 1913 was \$1.67, and in 1912, \$1.51, an increase of more than 10 per cent.

It has been the policy of the C. & S. to make considerably further investment in its property from surplus earnings. The total amount appropriated for additions and betterments from income since 1907 is \$4,278,000. While the net increase in the mortgage bonded and secured debt in 1913 was \$549,000, all of the proceeds were used for the purchase of securities of the Colorado Railroad Company and the retirement of certain bonds. There was spent for additions and betterments \$617,000. The four largest items of betterment expenditures are structures and machinery, substitution of permanent bridges for wooden ones, relaying with heavier rail, and ballasting on the Fort Worth & Denver City.

At the end of the year cash on hand amounted to \$908,000, as against \$747,000 at the beginning of the year, and total working liabilities amounted to \$1,507,000 at the end of the year, as against \$1,557,000 at the beginning of the year. During the year the Colorado & Southern cuts its dividend rate on the common

NEW BOOKS.

*Design of Plate Girders.*—By Lewis E. Moore, associate professor of structural engineering, Massachusetts Institute of Technology. Size 6 in. x 9 in.; 280 pages; 82 illustrations and 40 tables; cloth binding. Published by the McGraw-Hill Book Company, New York. Price \$3.

The author of "Design of Plate Girders" has attempted to make his treatment of a subject which has been covered in numerous books unique in that it seeks to develop the judgment of the student in making a choice between methods of design. Instead of laying down definite rules which students will follow blindly and without attempting to reason them out, it has been the endeavor to present several methods whenever possible, to indicate which is favored, and whenever possible, to present the various methods so that the student may select the one best suited to the particular need of the case in hand. Other features in which the book differs from many treatments of this subject are in the elimination of a large part of the discussion of methods of finding stresses and in the amplification of the treatment of rivets. The theory of plate girder design is set

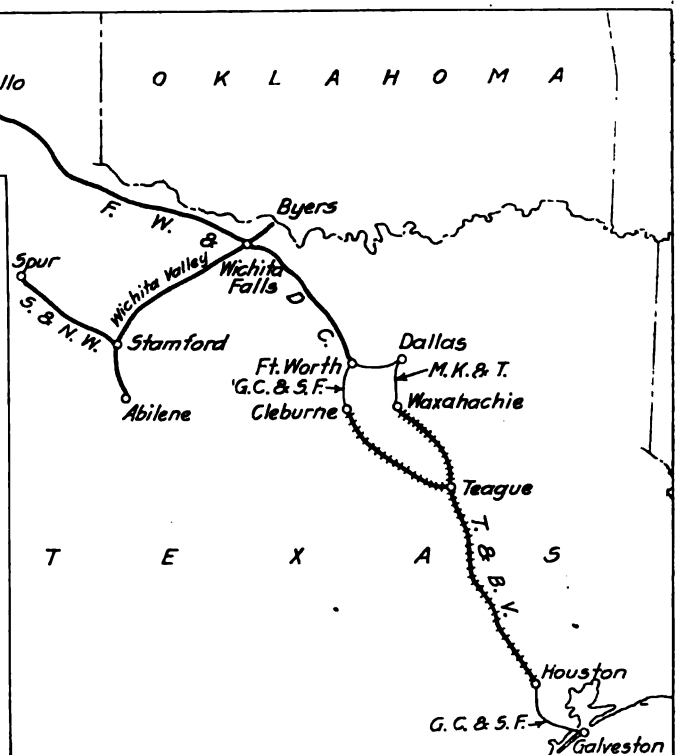

forth and two detailed designs are worked out with careful discussion of each point as it arises. A chapter on box girders and one on shop practice are also included. The tables at the back of the book are intended to serve the purpose of the practicing engineer and it is the author's hope, that they may prove of material assistance.

## Letters to the Editor.

### THE OVERLAP.

NEW YORK, November 6, 1913.

TO THE EDITOR OF THE RAILWAY AGE GAZETTE:

At the recent Washington convention of state railroad commissioners, Mr. Sague, of the New York commission, speaking on the general subject of safety, and referring particularly to the question of automatic train stops as a preventive of rear collisions, took the position that the overlap was an adequate safeguard; perhaps the one necessary safeguard, and entirely adequate. I have not his exact words before me, but I believe I correctly represent the substance of his opinion; that the automatic stop problem is so difficult and costly that it is the duty of the railroads to find, without further delay, something less difficult and more feasible. In view of the fact that one prominent road—the Pennsylvania, west of Pittsburgh—already uses the overlap extensively, this official utterance of the New York authorities may prove to be filled with significance. What shall we do? Are there sound, or even plausible reasons for keeping all trains two blocks apart, as a minimum (which means three blocks in fast running)?

I believe it is a fact that many, possibly most, signal people have condemned overlaps and now oppose them. Aside from spacing of trains as affecting the capacity of the road, there are two stock arguments on the line of safety and moral effect.

1. With the overlap (particularly the whole block overlap as on the Pennsylvania lines west and with provision for a caution indication at each signal) an automatic signal at stop almost invariably gives false information to the engineman of a train approaching it; the first stop signal encountered is pretty sure to be at the entrance to a clear block. It is morally wrong to give an indication of block occupied or obstructed when the block is clear.

Of course the answer to this is that signals give commands (or indicate the absence of commands), not information. No stop signal necessarily means that the track is obstructed within a specified distance ahead; that there is "danger"; that it is *unsafe* for a train to proceed. If the officers of a road decide that it is advisable to have a train stop (and then proceed carefully) when conditions at some point not less than  $\frac{3}{4}$  mile ahead are so-and-so, it is difficult to see that the engineman has any ground for quarrel with the arrangement or that there is ground for claiming that a deliberate attempt has been made to tell him something that is not true and thereby weaken his respect for signals and rules.

2. The engineman, knowing that there is almost certainly a clear block beyond the first stop automatic signal he comes to will not take such signals very seriously; will get into the habit of overrunning or disregarding them; and, finally, from force of habit, will overrun a second stop signal and strike a train just ahead. So that the road will be little or no safer with the overlap than without it.

The answer is that, on good railroads of today, this is not a serious contingency, because the old-fashioned observance of signals at discretion is being superseded by implicit obedience to signal-indications. The difficulty in these days comes from the overlooking or misreading of signals not (again referring to "good railroads") from practically deliberate disregard of signal indications because the visible conditions do not seem to justify the indications given.

Now, if the overlap is not subversive of sound operating principles, the question is simply, what remedy as good or better have we for the occasional wrecks which seem to occur because a single signal is misread or overlooked and which might, or, as to some at least, in all probability, would, have been prevented if a restricting signal indication had been given at a point farther back—that is, if there had been an overlap? As I see it, we

Americans have stood up uncompromisingly for the practice of giving a stop indication at a signal located at the point, or possible point, of obstruction—at the fouling point of a junction, the length of a detector bar from a facing-point switch or a few feet from the insulating joints at the entrance to an automatic block—on the assumption that any train approaching, having received a caution indication in the rear (perhaps), will certainly stop before passing the signal. But experience discredits the practice. In spite of the supposed best discipline, careful selection and training of men and the efficiency tests, trains don't always stop. What is to be done about it? I believe our English friends have pretty consistently maintained overlaps in their manual signal operation—perhaps sometimes absolute, sometimes permissive ("section clear, station or junction blocked"). How much of their wonderful accident record is due to this practice added to almost unfailing observance of signals by the "drivers"? Incidentally they don't seem to be satisfied themselves with their wonderful record; perhaps it is falling off lately; an American factor may be creeping into the personal equation. For I hear that they are paying some attention to automatic train-control.

Of course, in any event, the overlap would not be a cure-all. But, by giving a man two chances to note restricting indications, before reaching an obstruction, it might eliminate some wrecks; and there might be some chance that, if a man were running regardless (dead or unconscious, or the like), the other man on the engine would see one of the signals and save the situation.

It is an interesting question whether about the same result would not be obtained by having the signal at the entrance to an occupied automatic block at stop and the first and second signals in the rear at caution, as by having the first signal in the rear at stop and the second at caution (the overlap arrangement that we have been talking about). If the main trouble is the overlooking or misreading of the first restricting (caution) indication, a second indication of the same kind might serve the purpose; although it is possible that the emphatic or arresting quality of the stop indication (or aspect) encountered by a man running along in serene unconsciousness of having passed a caution signal might have some advantage. Trains would ordinarily be spaced just as far apart under one scheme as the other, because, ordinarily, one train should follow another at such a distance as to get clear signals. But the "caution" overlap would save some (possibly) unnecessary stops and starts.

Then, again, perhaps a cab signal, possibly with an audible attachment, would serve to emphasize the one and only caution indication in the rear of a final stopping point and would, at the same time, maintain the caution indication in the cab where the engineman could refer to it and refresh his memory if he had slipped past a signal location without noting the indication. There are also stock arguments against cab signals, but we must remember that we may not always be able to run railway signaling on stock arguments.

Now, what is the result? A lot of talk and no conclusion. A good many people feel no doubt, that "we need something." But whether we should do nothing at all, aside from trying to improve the human element, until we some time come to an ideal train control that will force an engineman to taper off from full speed to a stop between a caution and a stop signal, or should at once introduce some less complete checks—overlaps, cab signals, gatling guns, or whatever—seems to be the question. Again, I say, what are we going to do about it? S. E. A.

ORIGIN OF JAVA'S RAILWAYS.—Many of the steam tram lines in Java can hardly be distinguished from railways proper. Most of them had their origin as narrow-gage city tram lines carrying passengers only; but they have been extended from town to town, their gage widened, heavy rails laid, and freight and parcels service added. Up to the present time steam traction has been exclusively employed on these lines, but today most of them are planning to substitute electric traction for steam, the power in many cases to be obtained from hydroelectric plants.

# STUDIES IN OPERATION—THE CHESAPEAKE & OHIO.

An Increase of 187 Tons in Train Load in Two Years. What Is Being Done to Reap the Profit of This Gain in Efficiency.

Many of the points about the Chesapeake & Ohio situation well illustrate the entire eastern railroad situation. Despite remarkable gains in train loading of freight and largely increased passenger business, the results of operation on the C. & O. since 1910 have shown a falling off in net. Of course, flood conditions served to reduce abnormally the net results of the last year. But more important than this incident are the general underlying causes that have brought this about. The Chesapeake & Ohio has today traffic pressing for carriage which it cannot handle, because in part of its inability to furnish cars, and because of the inability of its connections to accept coal shipments. The situation is the more impressive in that the property was built up with high standards and has never been stinted either as to maintenance or betterment, and the line itself is not now congested.

The Chesapeake & Ohio is an independent trunk line, running from Newport News, Va., to Chicago by way of the West Virginia coal fields and Cincinnati. The company has a 45 per cent.

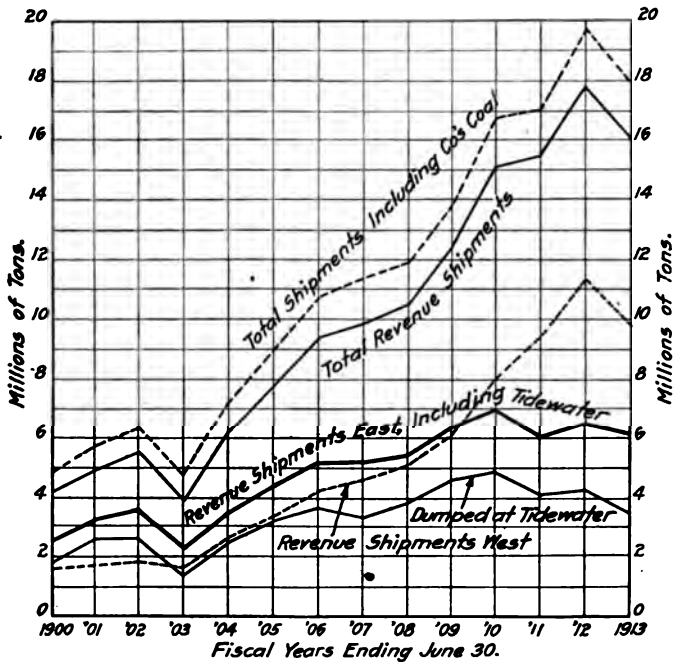

C. & O. Coal Shipments 1900 to 1913.

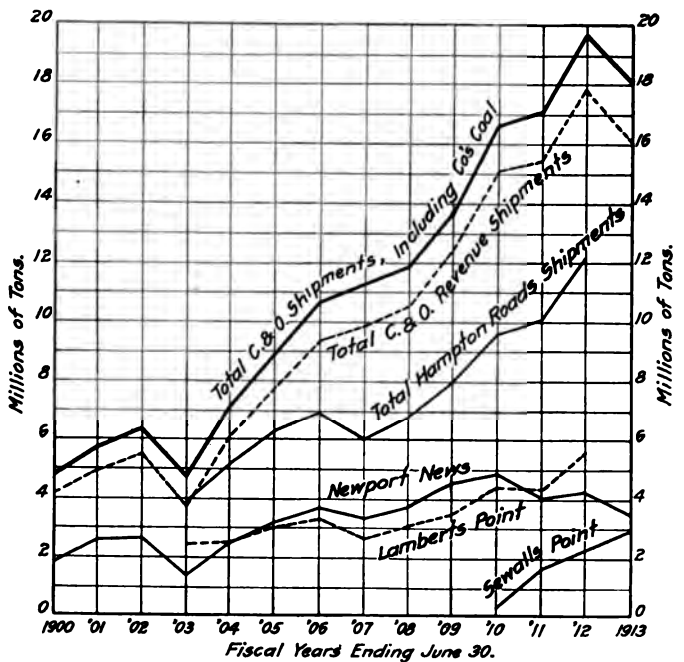

C. & O. Shipments and Other Tidewater Shipments.

interest in the Kanawha & Michigan and controls through majority stock ownership the Hocking Valley. Until a few years ago the road was practically controlled by the Pennsylvania and the New York Central Railroads, ran only as far west as Cincinnati, had no connection of its own to the lakes, and the bulk of its freight business was coal, of which at that time 40 per cent. moved from the West Virginia fields to tidewater, and the other 60 per cent. from the coal fields west. Although the ton mile rate on this coal was low, the haul was comparatively long and the cost of handling low. The Norfolk & Western, also controlled by the Pennsylvania Railroad, was one of the Chesapeake & Ohio's important competitors on this business. The Baltimore & Ohio and the Pennsylvania were also keen competitors and notwithstanding the fact that the P. R. R. had a considerable stock interest in the C. & O., it did not prevent the latter from making a most effective fight for coal business and from keeping the interests of operators on its line well protected against operators on the Pennsylvania and B. & O.

With the sale by the Pennsylvania of C. & O. control to in-

dependent interests and the advent of a strong new competitor, the Virginian Railway, the situation became more complex. The Virginian competition has cut into the C. & O. tidewater coal business but has hurt the N. & W. very little. The reason for this is that the coal operators on the N. & W. are so closely tied up to that company, through the ownership of the coal lands by Norfolk & Western interests, that the Virginian could not get in. To get Norfolk & Western coal, therefore, vessels have to go to the N. & W. docks at Norfolk. The operators on the C. & O. on the other hand in some cases owned their own spur tracks and made connections with the Virginian, thus having the choice of two routes to tidewater. They could not, however, ship coal west over the Virginian. Westbound shipments therefore have to go over the C. & O. Since the Virginian can keep its coal cars on its own line, it can furnish operators 100 per cent. of their car requirements for tidewater. Naturally the shippers turned to the Virginian as large a share as possible of their tidewater coal and used C. & O. cars for westbound ship-

ments. Furthermore, the Virginian dock at Norfolk permitted very much quicker loading of vessels than did the C. & O. dock. Vessels therefore preferred to go there for loading. The latter company is now taking steps to meet this situation by the erection of a modern coal dock that will be completed by April 1, 1914.

Coal shipments from West Virginia have increased enormously in the past few years, but since both the Virginian and the Norfolk & Western were in a better position to get the lion's share of the tidewater business, the Chesapeake & Ohio's increase in coal traffic has been mostly in the traffic westbound. To prepare for and to develop this business the bankrupt Chicago, Cincinnati & Louisville (the short line from Cincinnati to Chicago) and the Hocking Valley were bought in 1910, giving the C. & O. an outlet to the lakes and to the northwest; but while the Hocking Valley has already shown its value as an investment, the Chicago line is only now beginning to earn the interest charges on its cost.

There were serious difficulties in the way of the development of



business over both the Hocking Valley and the Chicago line. The three coal fields tributary to the Chesapeake & Ohio are the New River, east of Gauley, the Kanawha, between Gauley and Huntington, and the Kentucky fields, reached by the Big Sandy branch from Ashland. On coal from the New River fields for the Hocking Valley the C. & O. gets only a very short haul, and a division of the rate which allows it about 30 cents a ton. The coal is turned over to the Kanawha & Michigan at Gauley. Kanawha coal, if it were to be delivered to the Kanawha & Michigan, would have to be back-hauled and would yield the C. & O. but a meager division of the rate, beside being expensive to handle. Kentucky coal could not naturally be routed back over the C. & O. to Gauley or Charleston for destinations on the H. V. The C. & O. Kanawha and Kentucky coal for shipment to Toledo is routed via the C. H. & D. at Cincinnati, except when the latter gateway is congested as at present, in which event a portion is sent via Kenova, and N. & W. for delivery to the Hocking at Columbus.

The Chicago line, when the C. & O. bought it, was in poor physical shape. It was laid with the 70-lb. rail, with little or no ballast on the greater part of the line, and light bridges and trestles. It could handle but a small part of the business which the C. & O. might have delivered to it. The Chicago line exit from Cincinnati is over a short but very steep grade.

Here, then, was the situation in 1910 when the C. & O. itself was being worked to about the full limit of its economical capacity.

The Chicago line had to be improved; certain double track work on the C. & O. already begun had to be completed; it was of the utmost importance that a new dock be built at Newport News; new equipment was needed; and a C. & O. connection direct with the Hocking is an eventual necessity.

During the past few years the Chesapeake & Ohio has spent \$12,543,000 for second track and additions and betterments, excluding expenditures on the Chicago line; \$1,537,000 for extensions of branch lines, and \$12,805,000 for cars and locomotives. It must be remembered that the great growth in traffic on the C. & O. in the past four years has been in coal westbound. Of the expenditures for additions and betterments, however, some part were made on the eastern end of the line, on work which had already been begun, and the double tracking of the Cincinnati division was the most important and extensive piece of work done to lessen the cost of westbound movement.

The total mileage operated by the Chesapeake & Ohio in June, 1913, was 2,338 miles, of which 575 miles had second track; and the system had 971 miles of sidings. On double track, side tracks are from nine to 15 miles apart, and the freight trains are often compelled to back over on to the opposite main track to permit passenger trains to pass. The road is operated in seven divisions with road mileage as follows: Richmond, 455; Clifton Forge, 256; Hinton, 441; Huntington, 360; Cincinnati, 162; Ashland, 382; C. & O. of Indiana, 284. The Richmond division is divided into four districts; the Clifton Forge division into two; the Hinton division into three; the Huntington division into three; the Cincinnati division is not divided; the Ashland division into three, and the C. & O. of Indiana into two.

The following table shows certain important characteristics of traffic in 1911, 1912 and 1913:

	1913.	1912.	1911.
Revenue coal carried .....	16,047,704	17,845,159	15,782,002
Tonnage of manufactures.....	1,934,216	1,867,518	1,986,572
Total revenue tonnage carried..	25,174,241	26,147,903	24,604,650
Total revenue ton mileage.....	6,694,879,287	6,692,114,437	6,082,682,596
Revenue per ton per mile on coal (mills) .....	3.15	3.17	3.22
Revenue per ton per mile on freight other than coal (mills)	6.05	6.39	6.45
Average haul of all revenue freight .....	266	256	247
Number of passengers carried..	5,859,447	5,489,040	5,618,791
Passenger mileage .....	267,044,325	252,397,519	253,262,253
Revenue per passenger per mile (cents)	2.194	2.181	2.177

An idea of the relative business on these divisions may be had from the following table showing the revenue tons moved per mile of road in August, 1913, on each of the divisions:

Richmond .....	242,000	Cincinnati .....	889,618
Clifton Forge .....	301,666	Ashland .....	123,216
Hinton .....	242,004	C. & O. of Indiana.....	154,378
Huntington .....	296,171		

The most economical development of a railroad property consists, of course, in making each expenditure for additions or betterments fit into a general scheme for making the plant more efficient or for gaining additional business; and economies of operation are more quickly realized when the physical improvement of the plant goes hand in hand with and keeps at least abreast of the increase in traffic and the more efficient use of the plant. It has often been demonstrated that an increase in train load unaccompanied by the necessary higher standards of equipment and increased facilities for handling long trains, may result in higher instead of lower transportation expenses. Handling coal traffic on the Chesapeake & Ohio does not consist simply in loading the cars to their fullest capacity at the mines, moving them in solid train loads—each locomotive having its highest possible rating—uninterruptedly to tidewater and there dumping the coal into the holds of vessels. If it did the C. & O. ratio of transportation expenses to total operating revenues might compare with the Carolina, Clinchfield & Ohio, where the transportation ratio is less than 18 per cent. As a matter of fact, the transportation ratio in 1913 on the C. & O. was 32.5 per cent.; in 1912, 30.6 per cent., and in 1911, 30.9 per cent. The fact that the road has a large passenger business and a large freight business in merchandise and manufactures would preclude the possibility of obtaining any such transportation ratio as that on the C. C. & O. However, while the average revenue train load has increased from 656 tons in 1911 to 843 in 1913, the ratio of transportation expenses to total operating revenues has increased from 30.9 per cent. in 1911 to 32.5 per cent. in 1913, and this is due in large part to increase in wages, lower receipts per ton (not per ton mile, as will be explained more fully later), and to the unnatural conditions brought about by the floods. Still further economies may also result from adding more passing tracks, or possibly from the use of one track for drag freight only and working the other track as a single track for passenger trains, local freights and empties.

Large sums expended in repairing flood damages would no doubt have been put into additions and betterments but for this disaster. But in any case, a management cannot go to its board of directors and say, "We intend to increase the train load—you must take our word for that; but before we do so we wish you to provide additional facilities which will be needed when we do increase the train load." The management has first got to actually demonstrate the fact that it can increase the train load and then ask for further facilities. More especially is this true on a road which like the Chesapeake & Ohio, which has not had a long record of substantial dividend payments on its stock, and which has high fixed charges.

In 1911 the average revenue train load was 656 tons; in 1912, 756 tons, and in 1913, 843 tons. The increased train load is therefore now an accomplished fact and from an operating man's point of view the methods used to effect the increase are of themselves interesting.

HOW THE INCREASED TRAIN LOAD WAS OBTAINED.

As the company has, during the past three years, bought a good many new and powerful locomotives, the addition to the motive power would naturally be looked to for an explanation of the greater train load; but a little study of the division records shows some large increases on divisions where there were no new engines; and the true explanation of the 186 ton improvement is found to have been largely in the commonplace details of every day work. An officer of the road estimates that a considerable part of this improvement is in this feature.

Division.	Net tons per train mile.				Locomotives per train mile.			
	Fiscal year 1913-12.	Per cent. of increase	Fiscal year 1912-11.	Per cent. of increase	Fiscal year 1911-10.	Fiscal year 1913-12.	Fiscal year 1912-11.	Per cent. of increase
Richmond	854	2.9	830	5.4	774	103	102	1.03
Clifton Forge	924	18.0	868	8.1	780	116	112	1.12
Hinton	957	12.2	853	37.9	572	122	129	1.15
Huntington	975	4.0	934	19.5	733	111	118	1.11
Greenbrier	410	3.4	396	14.1	341	106	105	1.05
Cincinnati	1,550	62.0	957	5.8	892	103	107	1.07
Ashland	463	20.9	383	7.7	338	115	114	1.21
C. & O. of Ind.	576	34.9	427	23.3	326	135	133	1.12
Total	901	14.3	788	15.2	656	114	115	1.11

AVERAGE NUMBER OF LOCOMOTIVES IN FREIGHT SERVICE.

Division.	Fiscal year to June 30, 1913.				Fiscal year to June 30, 1912.				Fiscal year to June 30, 1911.			
	10-wheel.	Consol.	Mallet.	Mikado.	10-wheel.	Consol.	Mallet.	Mikado.	10-wheel.	Consol.	Mallet.	Mikado.
Richmond	2.3	42.0	0.4	2.0	2.9	44.1	..	1.0	2.9	47.2	..	..
Clifton Forge	2.0	38.3	..	..	1.6	37.2	..	..	1.8	38.1	..	..
Hinton	..	31.1	31.0	1.8	0.2	44.7	20.5	..	..	53.3	6.8	..
Huntington	1.5	38.3	1.3	13.3	2.5	55.8	..	..	3.8	47.7	..	..
Greenbrier	..	5.3	..	..	..	6.2	..	..	4.8	2.5	..	..
Cincinnati	1.8	7.0	..	17.4	6.1	32.5	..	0.4	3.7	37.4	..	..
Ashland	3.2	37.8	..	..	1.1	32.9	..	..	1.4	32.9	..	..
C. & O. of Ind.	0.6	36.7	..	..	2.3	32.8	..	..	0.7	20.2	..	..
Total	11.4	236.5	32.7	34.5	16.7	286.2	20.5	1.4	19.1	279.3	6.8	..

The locomotive runners now get more work out of their engines, the yardmasters are more careful to load engines to their full capacity, and the cars, especially coal, are more uniformly loaded with all that they can safely carry.

This extensive improvement was begun with the measurement of the work of all the engines in through freight service by a dynamometer. The dynamometer car of the Westinghouse Air Brake Company was secured in January, 1912, and for six months it was kept in constant service, being taken to all of the divisions of the road. It was used 8 weeks on the Huntington division; 8 weeks on the Hinton division; 2 weeks on the Clifton Forge division; 2 weeks on the Richmond division and 4 weeks on the Cincinnati division.

The management of this car was in the hands of Isaac Simpson, of the Westinghouse Company, and W. F. Walsh, air brake inspector of the Chesapeake & Ohio; and while, of course, the officers of the road, from the head down to road foremen of engines and the trainmasters, were constantly engaged in the campaign, these two men held the "center of the stage" in the work of improvement. Every engineman came in contact with them, and not only saw the records made by the instruments, but got a share of the enthusiasm which animated the man who made the tests. Science, as embodied in the car and its operations, and the skill which has its foundation in the long experience of the enginemen were combined, with a view to producing the best possible results; and evidently a marked success was accomplished. Practically all of the enginemen were runners of experience, thoroughly acquainted with their engines and with the road.

The 450 enginemen in through freight service were assigned to the principal divisions as follows: Richmond, 47; Clifton Forge, 101; Hinton, 138; Huntington, 65, and Cincinnati, 45.

The value of a dynamometer record as an index to the efficiency of a locomotive is recognized, of course, by everyone; but in a campaign to impress this idea on a large number of enginemen, and to do it without unnecessary loss of time, simplicity and directness are two essential elements in the process; and in this case the lessons were made both simple and direct by the use of a large indicator fixed on the side-wall of the car so as to be readable by a person standing anywhere in the car. On this indicator, the dial of which is about 18 in. in diameter, the pointer, moving with the fluctuations in the pull on the draw-bar, measured the work being done by the engine, mile by mile, so vividly as to impress the most careless or incredulous. In making the tests enginemen were temporarily relieved by the

road foreman so that they could go back into the car. After watching the dial for a while, any engineman who was disposed to make "claims" concerning the virtues or superiority of his past practice was very quickly convinced that only the cold facts could be of any avail. Watching the behavior of the engine and the readings of the indicator simultaneously, the accuracy of the machine was so evident that he had no word of criticism or complaint.

The recording apparatus not only indicated draw-bar pull and speed, but was made to show, by means of pens controlled through electric push-button circuits, by an observer riding on the locomotive (1) throttle lever opening; (2) reverse lever position; (3) boiler pressure, and (4) shovelfuls of coal supplied to the fire. Thus an engineman reading the record soon felt fully "at home," and if he entertained any jealousy of new-fangled tests, that feeling was quickly dissipated. As when one has his portrait taken, and first looks at the photographer's proof, the enginemen had to admit the primary fact that, whether favorable or unfavorable, the showing was a faithful and accurate reproduction.

With all of the runners fully impressed with (1) a fresh and detailed, and perhaps a revised, estimate of their own abilities; (2) with the fact that such an illuminating record could be made at any time, and (3) that alert officers, determined to make the best possible showing for the division, were studying these records and would compare one engineman with another, there was no difficulty in securing at once a very satisfactory spirit of emulation. Moreover, the enginemen did not have to learn anything radically new. No novel tricks were introduced. Each one had a new motive to do his very best at all times, and, with few exceptions, each already knew pretty well what his very best was, or ought to be; only he had not known it thoroughly enough to impel him at all times to work his mental machine to its highest efficiency.

In so far as working engines to their capacity increases engine failures, or breakages of drawbars, or abnormal delays in switching at way stations or in movements at meeting points, there is a loss; but this element has not been serious.

The tractive effort of the different classes of engines is as follows: Consolidation (279 engines in service January 1, 1913) 41,140 lbs.; Mikado (50 in service) 60,800 lbs.; Mallet (52 in

TYPICAL DAILY REPORT OF TRAIN TONNAGE—SLOW FREIGHT TRAINS.

District.	No. trains today.	Average tonnage today.	Total No. trains to date this month.	Average tonnage to date this month.	Average tonnage to corresponding date last month.	Per cent. of tonnage rating handled this date	Per cent. of tonnage rating handled to date this month.
Peninsula	E 3	4152	56	4155	4175	100	100
Peninsula	W 3	1900	69	1807	1942	85	81
Rivanna	E 5	4489	100	4494	4544	100	100
Rivanna	W 5	1435	117	1432	1438	69	69
Piedmont	W 1	1000	31	1080	1018	80	82
Washington	E 2	1100	44	1100	1100	100	100
Mountain	E 1	750	17	810	1073	28	68
James River	E 4	4485	97	4431	4427	100	100
James River	W 5	1542	132	1464	1479	100	99
Alleghany	E 7	4491	148	4404	4346	100	99
New River	E 10	3599	206	3413	3334	100	98
Greenbrier	W ..	..	6	2644	2696	..	88
Kanawha	W 3	3948	97	3978	3624	100	99
Guyandotte	W 7	3659	127	3526	3419	96	100
Lexington	W 2	975	49	1057	1047	100	99
Louisville	W 1	1173	1	1173	141	98	98
Big Sandy	W 3	3189	82	3125	3177	106	103
Cincinnati	W 8	5400	157	5217	5017	100	100
Miami	W 1	2100	25	2098	2052	100	100
Wabash	W 1	2383	35	2383	2338	99	100
Between Summit & Boston	W 4	2135	75	1921	1896	100	100

service) 82,000 lbs. working compound and 98,500 lbs. working simple.

The improvement in efficiency due to the increased number of large locomotives may be understood by the statement of engines in service in different districts.

The most marked improvement in a divisional record with no

change in the character of the locomotive was that on the Richmond division, the average train load for the year ending June 30, 1912, being 830 tons, as compared with 789 for the year previous, a gain of 5.2 per cent.

The greatest increase on a single division was that of 38 per cent. on the Hinton division (572 to 789). Here, besides an increase from 223,000 to 693,000 miles made by Mallet engines of 82,000 lbs. tractive effort (98,500 lbs. simple) trains were double-headed more in 1912 than in 1911, the average number of engines per train mile rising from 1.15 to 1.29.

On the Cincinnati division for year ending June 30, 1913, the average train load was 1,550 tons, as against 944 in 1911, an increase of 606, over 39 per cent.; and there was a decrease in doubleheading.

On the Chesapeake & Ohio of Indiana, for the year ending June 30, 1913, was 578 tons as against 427 tons last year, an increase of 60 per cent.

The inclusion of the figures of the C. & O. of Indiana materially lowers the average train load over the entire system, and conversely, of course, the improvement on the Chicago line is bringing up the general average. This is an important factor to bear in mind when considering the possibilities of further improvement.

Even in the present months of heavy freight movement the Chesapeake & Ohio is not badly short of locomotives. The use of Mallet engines is being extended and with the increase in the average size of locomotives the freight train load will undoubtedly be further increased; but the all important point is that the keying up of the organization to a larger train load has been actually accomplished.

The only object in getting a greater average train load is to reduce transportation expenses per unit of traffic handled, or if not to actually reduce, at least to offset increases in these unit costs due to other causes.

Total transportation expenses in 1911 amounted to \$9,192,005; in 1912 to \$10,503,415, and in 1913 to \$11,380,998. The Chesapeake & Ohio for its own use makes a particularly good, common sense division of transportation expenses as between supervision; despatching, telegraph and signals; station expenses; yard expenses; passenger-train expenses; freight-train expenses; claims and damages; miscellaneous expenses, and joint operating expenses. The great saving that should be made by increased freight train loading would come, of course, in freight train expenses. These expenses in 1911 amounted to \$3,565,968; in 1912 to \$3,947,021, and in 1913 to \$4,117,199. The cost of freight train expenses per 100 revenue miles in 1911 was 6.10 cents; in 1912, 5.90 cents, and in 1913, 6.15 cents. Increases in wages made the 1913 about \$1,500,000 higher than they would have been with the same force if 1910 wage scales had been in effect. In other words, insofar as freight train expenses are concerned, the increases made in train loading have a little more than offset the great increases in expenses due to higher wages paid to train crews, somewhat higher fuel costs and the very materially high costs due to the flood in 1913 and its after effects. The total freight train expenses per train mile in 1911 were 41.83 cents; in 1912, 44.81 cents, and in 1913, 51.87 cents. Passenger train expenses per passenger train mile were 27.48 cents in 1911, 27.25 cents in 1912 and 29.56 cents in 1913. Thus train expenses per passenger train mile have increased between 7 and 8 per cent., while train expenses per freight train mile has increased nearly 24 per cent. With larger locomotives and heavier freight trains expenses per mile would naturally increase and, of course, the ton mile cost is the time measure of economy of operation.

Increase in trainmen's wages would affect passenger train expenses in about the same proportion as freight train expenses; but the flood and its after effects would affect freight train expenses to a far greater degree than passenger train expenses. This for two principal reasons. While the C. &

O. itself was still feeling the effects of the flood and train service was delayed on that account, passenger service was, of course, give the preference and freight movement suffered in a dozen different ways; the devil of overtime takes the hind most. This cause, was operative only while the C. & O. was itself recovering from flood damage which was only for about one month. Some of the lines to which the C. & O. delivers its freight have not even yet recovered from the damage due to the flood, and the inability of connecting carriers to accept freight is the other important cause of the increase in transportation expenses in freight service on the Chesapeake & Ohio. Yard expenses reflect the very great increases in wages of yard employees' wages. In 1911 the total was \$1,902,501; in 1912, \$2,120,737, and in 1913, \$2,361,995. This is a total increase of 24 per cent., with, it will be remembered, an increase of 10 per cent. in ton mileage handled. Overtime in 1912 cost 2.08 cents per train mile, which was slightly lower than the cost in 1911, but in 1913 it amounted to 4.11 cents, showing in some small part the effect of the delay caused by washouts, etc., and the delay due to congestion at Cincinnati because of the inability of connecting carriers to accept shipments, but even more the effect of a change in working conditions. Actual time spent on the road is not now much greater—if any greater—than in 1911.

#### CONCLUSIONS.

This, then, is the Chesapeake & Ohio situation. Serving a territory which furnishes a large passenger business, the road has largely increased its passenger service in the last few years, and with this increase in passenger business has gone a very large increase in merchandise business and a tremendous increase in the movement of coal west from the west Virginia coal fields. Heavier locomotives have been added and the freight train load has been increased remarkably. But despite this fact, and despite the fact that there is no congestion on the Chesapeake & Ohio itself, expenses have increased out of proportion to the increase in gross earnings. The C. & O. could obtain at present 20 per cent. more coal shipments a day if it could supply the cars for loading and get loaded cars accepted by its connections. The C. & O. owns plenty of cars but when they are loaded it can not get its connections to take them and it cannot get empties back after loaded cars have gone to connections. The most profitable part of the C. & O. business is its coal business, and the coal business to tidewater is more profitable than the business, as now handled, from the Kanawha and Kentucky fields to the west. Not only must the Chesapeake & Ohio equip itself to handle a larger business, but it is under the necessity also of earning a fair return on the property investment with very low ton mile rates.

To make the operation of the property such as to save for net a fair proportion of the gains which should result from the already very large average train load, some new side tracks should be built and a number of existing tracks lengthened; and there should also be certain additions to terminal and shop facilities. A rough estimate of the cost of such additions and betterments would be \$1,500,000. To become in part independent of the difficulties due to the inability of connecting carriers to receive freight, the Chicago line should be further strengthened so as to permit of the use of Mallet locomotives and correspondingly heavy train loads, with certain changes of grade and alignment. costing, we will say, in the neighborhood of \$2,000,000, but this is considered a requirement of the future rather than a present necessity.

Since the Chesapeake & Ohio cannot afford to simply perform a switching service for coal going to the lakes, it must do something to get a larger division of the through rate on lake coal. The obvious method of doing this would be to build a connection from some point west of Russell-

yard to the Hocking Valley. Such a connection might possibly be built for about \$6,000,000.

The company must also from year to year add new equipment and replace light cars with modern large capacity cars. The company is now spending about \$1,500,000 for a new dock at Newport News which when completed will give it facilities not only for loading vessels as rapidly as the Virginian dock but will permit of loading vessels at both sides of the dock at the same time. In other words, there will be two complete plants, elevators and all. The Virginian dock loads on either side but is a single plant. The C. & O. is about to receive 2,000 70-ton gondola cars, which can be used *only* for tidewater business with the new dock facilities, and with these 70-ton cars, coal operators will have the necessary incentive to ship their tidewater coal over the Chesapeake & Ohio, which will enable the latter to recover a greater portion of its lost tidewater business. With a connection with the Hocking, the C. & O. can amply take care of its operators with markets at Toledo and the northwest and relieve the congestion at Cincinnati. These improvements will necessitate further investment in the property. To induce further investment railroad credit must be strengthened.

Not the most ardent of shippers or the most altruistic theorist can claim that 5 per cent. increase above 3.15 mills per ton per mile would make more than a reasonable rate for the transportation of coal; but the importance of the moral effect on railroad credit, of allowing an increase would, right here in the Chesapeake & Ohio case, be so very much greater than the direct increase in net earnings that for the purpose of the study of the needs of the property and of its problems, the direct increase in net might well be entirely neglected. The importance to coal operators of West Virginia in the development of their property, of adequate railroad facilities, is almost incalculable. It may well be that the Chesapeake & Ohio can increase its business other than coal, continue to some extent to increase its efficiency in the use of its present facilities, and so continue to earn a moderate profit; but can the shippers in C. & O. territory possibly afford to forego the opportunity which they have of developing their business through an increase in the facilities of this railroad? That is the responsibility that the Interstate Commerce Commission must face in the present rate hearing.

**THE GAGE OF CHINESE RAILWAYS.**—The railways of China have been constructed very largely without regard to a national system. Each road is more or less local, not only in its interests and support, but in its physical characteristics. Where interests other than Chinese have impressed themselves upon the railways, they have insisted upon following their own ideas and plans, their own gage, their own rails and materials, and their own railway methods. The result is that from a physical standpoint China has not what in any sense may be called a homogeneous and national railway system. The welding of the many lines now constructed or being constructed into one homogeneous system, or even into several homogeneous systems, will be exceedingly difficult because of differences in gage. As a rule, China has adopted the 4 ft. 8½ in. gage, but several important lines are of a different gage. For example, the new line in Yunnan has used the meter gage, and the Kwangsi authorities appear to have determined to break away from what is supposed to be the standard, and have either the meter or a narrower gage. What the conversion of these lines to a standard Chinese gage will cost may be appreciated from the expenditures Japan is finding necessary in widening the gage of its Tokyo-Shimonoseki line. This will mean business in the future, but prevents business on a standardized scale for the present. Some of the more recently constructed roads are in fine physical condition. In fact most of them have been constructed upon too costly a scale for the traffic they are likely to get for a great many years to come.

## THE RAILWAY EMPLOYEE AND THE RAILWAY PATRON.\*

BY SAMUEL O. DUNN.

There are three classes of persons who are interested in railway management and operation and their results. These are, the owners and managers of the railways, the employees of the railways, and railway patrons. In the class of railway patrons belongs practically the entire public. It is to the interest of all of these classes that each of them shall be fairly dealt with; but it is especially to the interest of each two of them that the other shall not get an unfair advantage over them.

The relations between the railway managers and owners, on the one side, and railway patrons, on the other, have been thoroughly ventilated and extensively dealt with in recent years. A system of public regulation has been developed which has greatly improved these relations, and which seems adapted to remedy any serious defects which still exist in them or which may develop. Meantime, important changes have been taking place in the relations between railway employees, on the one hand, and the railways and railway patrons, on the other.

The patrons of the railways—using that term in its broadest sense—are interested in railway management and operation chiefly from two points of view. They desire the railways to be economically operated, for on the cost of producing transportation depend the rates for which it may be sold. The reasons why they are concerned as to the safety of transportation are equally obvious. Now, it is well known that until within the last decade railway rates in this country rapidly declined. It is also well known that during the last decade this decline has ceased, and that now the railways are petitioning for advances in rates on the ground that they must have larger net earnings in order to remain solvent and make needed improvements and extensions. Different persons offer different explanations for the trouble in which the railways find themselves. Some assert that their net earnings have enormously increased, but that they have "watered" their capitalization, and that it is for the purpose of paying a return on their watered securities that they need more net revenue. Others concede that their trouble is due to increases in operating expenses, but assert that these increases have taken place chiefly in the expenses incurred in the purchase of supplies and equipment, and are largely due to questionable relations between railways and their directors and officers, and railway supply concerns. Finally, railway officers contend that the trouble of the railways is due chiefly to enormous increases in the wages paid to labor unaccompanied by increases in the efficiency of labor, but rather accompanied by decreases in its efficiency.

The last decade has been a period of great industrial and commercial expansion. It has also been a period of substantial growth of railway mileage and traffic. In such a period we should expect to find that there had been a large increase in railway gross earnings. It is well known that during this decade the railways expended large sums in the improvement of their roadway, the reduction of grades, the elimination of curves and the acquisition of more powerful locomotives and larger cars. One of the main purposes of these expenditures, involving the investment of large sums of new capital on which a return must be paid, has been to reduce the cost of operation, and especially the cost of labor, and thereby increase the net earnings available for improvements and return on capital. We should, therefore, expect to find that during this period there was a very large increase in net earnings. Meantime, there were substantial advances in the prices of commodities, and in house-rentals, etc., which raised the cost of living. Therefore, we should also expect to find that there had been large advances in the rates of wages paid to employees.

\*Abstract of an address before the Traffic Club of Chicago, November 25, 1913.

But while we should expect to find that there had occurred increases in the rates of wages paid, we might also expect to find that the tendency toward an increase in the total cost of labor due to this would be very largely counteracted by the effect of the expensive improvements which have been made for the express purpose of making savings in labor and labor costs.

In consequence, we might expect to find that the total increase in the cost of railway labor had been at least no greater in proportion than the increases in gross earnings, in other operating expenses and in net earnings.

Now, what are the facts? The total earnings have largely increased. What has been and is being done with the money? I have made a table based on the statistics of the Interstate Commerce Commission for the years 1901 and 1911, which shows the absolute increases, and the percentages of increase, during this ten years in the ton-miles of freight traffic, in the passenger-miles of passenger traffic, in the gross earnings, in the operating expenses, in the net earnings, in the operating expenses other than the wages of labor, and in the wages of labor, on the railways of the United States. This table is as follows:

	1901.	1911.	Increase.	Inc. P. C.
Tons carried one mile.	147,077,136,040	253,783,701,839	106,706,565,799	72.5
Passengers carried one mile	17,353,588,444	33,201,694,699	15,848,106,255	91.3
Gross earnings	\$1,588,526,037	\$2,789,761,669	\$1,201,235,632	75.6
Operating expenses	\$1,030,397,270	\$1,915,054,005	\$884,656,735	85.8
Net earnings	\$558,128,767	\$874,707,664	\$316,578,897	56.7
Operating expenses other than wages of labor (including salaries of officers)	\$441,880,186	\$746,451,800	\$304,571,614	68.9
Wages of labor	\$588,517,084	\$1,168,602,205	\$580,085,131	98.5

This table shows that while the freight traffic carried increased 72.5 per cent., the passenger traffic carried 91.3 per cent., the gross earnings 75.6 per cent., the total operating expenses 85.8 per cent., the net earnings 56.7 per cent., and the operating expenses other than wages of labor 68.9 per cent., the total wages of labor, in spite of all the improvements made to reduce the cost of labor, increased 98½ per cent. The increase in the cost of labor almost equaled the increases in net earnings and in all other operating expenses combined. Out of every dollar added to gross earnings, 26.3 cents were added to net earnings to be used to pay return on capital, to make additions and betterments, etc.; and 25.3 cents were added to official salaries and to the amount paid for materials, equipment, fuel, etc.; while 48.4 cents were added to the wages of labor. This shows clearly where the money has gone, thereby explaining the present apparent need for higher rates.

This enormous and disproportionate increase in the cost of labor, occurring as it did at the very time when large capital expenditures were being made and innumerable improvements in operating methods were being introduced to reduce labor costs is really astonishing, when you consider it in all its bearings. And is labor now satisfied?

Quite the contrary. It is just as dissatisfied as ten years ago. Almost daily new demands for easier conditions of work and higher pay are presented. An arbitration board has just awarded the conductors and trainmen in the east an advance in wages. The engineers and firemen on all the railways of the west are at this moment demanding substantial improvements in their conditions of work and very large increases in their rates of wages.

Now, how have these disproportionate increases in the cost of labor been brought about? They have been brought about largely by increases in the scales of wages paid, and especially in those of the organized employees. Between 1901 and 1911 the average daily wage of enginemen increased 27 per cent., that of conductors 31 per cent., that of machinists over 35 per cent., that of firemen 36 per cent., that of trainmen 44 per cent. Most of the advances have been made as a result of arbitration under federal law; and the awards have been based chiefly on the ground that there has been a rise in the cost of living.

But if the increases in the cost of living are a sufficient ground on which to base advances in the wages of railway employees.

then they are a sufficient ground on which to base increases in the wages of all other working people. The main causes of the past increases in the cost of living have been increases in the prices of the products of the factory and the farm, for the average charges for railway transportation have remained stationary. These increases in prices have affected the cost of living of all alike, and, therefore, if advances were to be made in the wages of railway employees, only, an unfair discrimination would be worked in their favor as against other laboring people. If, on the other hand, general increases in wages occur in all industries the effect must be to increase the cost of production in all industries. But if the cost of production in all industries is increased, then prices in general must be increased, which must cause a further increase in the cost of living, which upon the theory in question, must justify further increases in the wages of labor, which will cause further increases in the cost of living, and so on, ad infinitum.

There is something radically wrong with a theory of wages which leads to such conclusions. The trouble with it is that it assumes that wages should be based almost entirely on the needs of those receiving them, whereas they should be based not only on their needs, but also on their deserts. Now, their deserts depend on their efficiency as producers, and their efficiency as producers depends on the quantity and quality of the work which they do. Obviously, the smaller the quantity and the more inferior the quality of the work which laboring men do, the higher, other things being equal, will they raise the cost of production and the higher will they make the cost of living; and, in consequence, to increase wages with each increase in the cost of living might be merely to increase wages in proportion as the quantity of work done by those receiving them diminished and its quality deteriorated. It is always most pertinent, therefore, to inquire, when the fairness of past and pending increases in wages is under consideration, not only whether the cost of living has been and is rising, but also whether the quantity and quality of the work done by those asking for the higher wages have been and are changing, and, if so, in what direction.

Railway officers claim that the efficiency of the organized classes of railway labor has been declining; and the evidence indicates that while these classes contain many individual workmen of high efficiency, they have not, as classes, co-operated with the managements in their efforts to promote the economy of operation, but, on the contrary, have antagonized and resisted, and do today antagonize and resist, almost every effort to promote economy. For example, the managements have introduced more powerful locomotives to save operating expenses, and the enginemen have sought to minimize the effects produced by demanding much higher wages for running these engines than for running the smaller engines. In order to effect the economies made practicable by the reductions of grades that have been made, and the more powerful engines and larger cars that have been introduced, it is essential to increase the tons hauled per train without correspondingly increasing labor costs. The trainmen have met the efforts to increase train loads by demanding increases in the number of trainmen employed per train, and, having failed to secure from the managements the concessions sought, they are getting so-called "full train crew" laws passed by the state legislatures throughout the country. In order to effect economies in the shops, the railway managements have tried in greater or less measure to introduce methods of so-called "scientific management." The employees have resisted, thereby making it necessary, where these methods are introduced, for the railways to spend so much money for supervision as largely to nullify the effect of the improved methods. In order to economize in the operation of branch lines some railways have substituted motor cars for steam locomotives and trains; and the engine and train employees have insisted that their "rights" should be extended and their wages applied on these cars, which would largely nullify the possible savings. Similarly, where steam lines have been electrified, the employees have insisted that the high wages of steam enginemen and fire-

men should be applied, rather than the lower wages ordinarily paid to motormen and their helpers on electric lines. And so it has been and is all along the line. The increases in labor costs have been due to these things as well as to the advances in the daily rates of wages.

They have been further due to the general basis on which the wages per day and the overtime payments of employees in the engine and train service have been adjusted. Generally speaking, the basis of a day's wage in engine or train service has been ten hours or 100 miles. In numerous cases, however, employees receive a full day's wage when they have neither worked ten hours nor run 100 miles, and in numerous other cases they receive more than a day's wage when they have neither worked more than ten hours nor run more than 100 miles. Suppose that a locomotive engineer is called to report for duty at point A at 8:00 a. m., but does not leave with his engine until 9:40; and that in the next three hours he runs 100 miles to point B. He has been on duty only 4 hours and 40 minutes, and has run only 100 miles, yet he receives pay for 120 miles, or 20 per cent. more than a day's wage. Why is this? It is because his brotherhood has successfully insisted that he shall receive a day's wage for running 100 miles, and, in addition, two hours' wages for the hour and 40 minutes during which he was on duty before he took out his engine. Suppose, again, that a fireman goes on duty at 8:00 a. m. at A and proceeds to B, arriving there at 9:00 a. m. There is a wreck ahead, and until 2 o'clock he aids in clearing it up, after which he proceeds to C, a distance of 100 miles from A, arriving there at 3:00 p. m. He has been on duty only seven hours and has run only 100 miles, yet he gets 130 per cent. of a day's pay. Why? He receives a day's wage for the 100 miles which he ran, and three hours' pay, besides, for the three hours in which he was engaged in helping clear up the wreck ahead of him. Again, a conductor reports for duty at 7:00 a. m., and is employed on a work train until noon, a period of five hours. He then runs from A to B, a distance of 100 miles, arriving there at 4:00 p. m. He has been on duty only nine hours, and yet he receives 150 per cent. of a day's wage. Why? Because he gets a day's wage for the 100 miles he has run, and additional pay for the five hours during which he was on the work train.

As 100 miles, or ten hours, is the recognized basis for a day's wage, it does not seem that there would be anything unreasonable in demanding that employees should either work more than ten hours or run more than 100 miles before receiving more than a day's pay. The employees have been demanding that in passenger train service 100 miles or five hours shall be the basis of a day's wage. This principle has been recognized in one of the recent arbitration awards in the east, and its application in the west is demanded in the proposals recently submitted to the western roads by their enginemen and firemen. On that basis if a train ran only 50 miles, and from any cause it took five hours to cover that distance all the employees on it would be entitled to a day's wage, and if for any reason it ran only 100 miles in ten hours they would be entitled to two days' pay.

There is something fundamentally wrong with a scheme of wages which works out such results, and the effect of which must be, it would seem, to make the cost of transportation, and, therefore, the rates that must be charged travelers and shippers for it, excessive in proportion to the amount of labor actually done to produce it.

The demands which the western enginemen and firemen are pressing on the railways, and which doubtless in a short time will be a subject of general discussion or of arbitration, afford many striking illustrations of the efforts constantly made by the brotherhoods to increase the wages received by their members for doing a given quantity and quality of work, or to reduce the quantity and quality of work done by them for a given wage. For example, they demand wages 23 to 50 per cent. higher for running Mallet engines than for running other freight engines. Now, that there ought to be some differential probably is true, and there already is one; but that the differential should be

from 23 to 50 per cent. does not seem reasonable. Again, they demand pay for 30 minutes' preparatory time in addition to pay for their regular day's work. In other words, although ten hours or 100 miles is the basis of a day's wages, they insist that if a man comes on duty at 9:00 a. m., and then runs 100 miles in, say, six hours, he shall be paid a day's wage and for 30 minutes' time besides. Take another illustration. Suppose the employee's train is scheduled to depart at 9 o'clock; that it does not leave until an hour later; and that it runs 100 miles in four hours. Under existing schedules the employee would receive a day's wage for running the 100 miles in four hours and 10 per cent. additional for the hour which he waited; and if the pending demand of the employees should be granted he would receive, besides, additional pay for his 30 minutes' preparatory time, although the whole time that he was on duty would actually be only five hours.

It is ordinarily assumed that controversies arising between the railways and their employees regarding wages and conditions of employment, and especially the details of such controversies, are of interest and concern only to them. What has been said shows that these things are of vital interest and concern to the public generally. The changes in wages and conditions of work have not yet caused increases in the average passenger and freight rates, which are about the same as they were ten years ago. But it is perfectly evident from a study of the statistics that the time is here when the various conditions which are operating on the railways, and especially the increases in the cost of labor, already prevent reductions and must compel increases in railway rates. The public is already sharing with the railway companies, and must share in a larger measure, in bearing the burdens imposed.

No one can rationally or fairly blame railway employees for organizing. If we were railway employees we doubtless would belong to the brotherhoods. Nor can anyone rationally criticize the employees for seeking higher wages when they believe they are entitled to them. But the public has a right to insist that railway employees shall not be unreasonable in their demands, and it is its right and its duty to itself to provide means for ascertaining whether their demands and conduct are reasonable and to help to make them so. It is not right or expedient that any class in a community should get more than it is entitled to, because when it does it takes the excess from those who have a better claim to it. Now, many railway labor controversies are settled by arbitration at present. But the situation with respect to arbitration cannot be regarded as satisfactory. In the first place, either party can refuse mediation or arbitration, thereby precipitating a strike or lockout and a railway tie-up which may be exceedingly costly to the public. The enginemen, firemen, conductors and trainmen on the Sunset Lines in Texas only recently struck after the railway had asked mediation under the federal law and the proper federal officers had tendered such mediation. Furthermore, even when these controversies go to mediation or arbitration there is no adequate machinery for settling them on their merits. The awards now made are usually mere compromises which really settle nothing, but which almost always cause increases in railway expenses.

It would seem, therefore, that the time has come when travelers, shippers and the public generally should begin to take a very active interest in the question whether the employees of railways are not demanding and getting too much or giving too little for what they get; for in the long run public opinion settles matters of this kind; and also in the long run, in the form either of freight and passenger rates or of stunted railway facilities, the public will pay every cent which is added to the cost of railway labor. It would seem, also, that the time has about come when strikes and lockouts on railways before arbitration should be prohibited as contrary to public policy, and when some permanent body such as the Interstate Commerce Commission should be empowered scientifically to investigate and pass on the

But while we should expect to find increases in the rates of wages paid, we find that the tendency toward an increase in labor due to this would be very largely counteracted by the expensive improvements which have been made. Rate controversies are now investigated and determined on their merits. Of course, the labor brotherhoods will oppose any such legislation. But will there be any more merit in their opposition than there was in that offered by the railways to the proposal to give the Interstate Commerce Commission power, when it found a rate unreasonable, to fix a rate that was reasonable? And when these labor controversies are investigated on their merits, the investigators will not stop when they have ascertained whether the cost of living has increased, but they will also inquire whether the quantity and quality of the work done by railway employees has changed, and, if so, in what direction. And while shippers, travelers and the public generally are considering these matters, it will be well for them to consider also the activities of the lobbyists of the railway brotherhoods in securing the passage of legislation which tends to increase railway expenses. Our friends among the shippers are quick to appreciate the effect which may be produced on their businesses by an increase in railway rates. They have heretofore been much less quick to think and act when railway employees have knocked at the doors of state legislatures and Congress demanding legislation adapted to increase railway expenses and thereby to interfere with reductions or compel increases in railway rates.

As already indicated, railway patrons are interested in the same degree in the influences which affect the safety of transportation as in the influences which affect its cost. Now, it cannot be controverted that the accident record of the railways of this country is very unsatisfactory. More than one-half of the fatalities are due to trespassing, which can be stopped only by the passage of better laws and their enforcement. A very substantial number of accidents are due to defects of the physical plant. But the large majority of them, other than those due to trespassing, are due to careless or reckless conduct of employees. The only way to remedy the accidents due to physical defects is to make large additional investments for improvements in the plants. Unwise and unnecessary increases of expenses, as well as unwise and unnecessary limitations of rates and gross earnings, restrict the net earnings from which all the money for improvements must directly or indirectly come. When, for example, railway employees secure legislation requiring additional men in train crews and thereby increasing operating expenses, they make encroachments on net earnings which reduce the money available with which directly or indirectly to install block signals, buy steel cars, eliminate grade crossings, and so on. Again when the employees fail to give to the companies and thereby to the public the careful and loyal service which they should, and their brotherhoods interfere with the discipline which properly should be administered for careless or disobedient conduct, they unnecessarily increase both the expenses of operation and the danger of accidents. It often has been charged that the brotherhoods through their grievance committees have interfered with discipline. The charge often has been denied. The evidence is against those who make the denial. Some specific examples will throw light on the question. The purpose of block signals is to inform trainmen, and especially engineers, whether the track ahead is in shape for them to proceed. It is essential to safety that these signals be implicitly obeyed. In order to ascertain whether they are being obeyed, railway managers have found it necessary to make surprise signal tests; in other words, deliberately to set the signals against the engineers and observe what they do. The employees, and especially the engineers, protest against surprise tests, and one of the demands made by the engineers

and firemen in the negotiations pending at this moment between them and the western railways is that the practice of conducting surprise tests shall be eliminated. Whatever may be the reason avowed for this opposition to surprise tests, the real reason appears to be that by means of them employees who are disregarding signals are detected and made subject to punishment.

Is it not about time that the public began to appreciate the close relation between the railway accident record and the attitude and conduct of the railway employees and their brotherhoods? The great weakness of the railway managements in dealing with questions of discipline heretofore has been want of understanding of these matters on the part of the public, and consequent fear on the part of the managements that in case of strikes public sympathy would side with the strikers.

We will approach more intelligently and discriminatingly these questions pertaining to the relations between the railways and the public, on the one hand, and the railway employees, on the other, when we get clearly and kept firmly in mind the fact that human nature is the same in all the walks of life, and that, therefore, it is just as easy and natural for a large number of men who are organized into a labor union to be unreasonable as it is for a large number of persons who are organized into a corporation to be so; and that it is just as easy and natural for the men higher up in a labor brotherhood to abuse their power and disregard the rights of others as it is for the men higher up in a railway corporation to do so. And when the members and officers of a labor brotherhood are unreasonable and unfair it is just as much our duty to criticize them and just as much the duty of the public to itself to check them, as it is our duty to criticize and check the officers and stockholders of a corporation when they are unreasonable and unfair. It seems to be assumed that it is to the public interest to let railway labor have almost everything it wants, while it is not to the public interest to deal similarly with the investors in and officers of railway corporations. The fact, however, is that the investors in and managers of railways are at least as numerous a body of the citizens of this country as the employees of railways, and that, therefore, there is no public interest served by letting railway employees have anything to which they cannot show a clear right, any more than there is a public interest served by letting railway security-holders have anything to which they cannot show a clear right. The interstate commerce act provides that when railways seek to make an advance in their freight rates the burden of proving that the advance is reasonable lies on them, and this in spite of the fact that railway rates are as low today as they ever were in the history of the United States. In view of the fact that the wages of railway employees have been very greatly increased in recent years, and that changes in their wages and conditions of work are made, in the long run, at the public expense, does it not seem that the time has about come when the public may properly say to them that upon them also the burden of proof now rests and that they must clearly demonstrate their right to any further ameliorations in their conditions of work and increase in their rates of pay before they should or will be granted?

EARNINGS OF SOUTH AUSTRALIAN RAILWAYS.—The year ending June 30, 1913, was a notable one for the South Australian government railways. For the past nine years they have been earning profits of 5 per cent. and more on the investment and this has been more than sufficient to cover the current interest on capital. There were, however, arrears to make up in the shape of sums expended by the government in former years for railway interest out of general revenue. During the year under review these arrears were wiped out and the railways are left for the first time in their history with a credit balance amounting to \$1,310,505.

# SUMMIT-HALLSTEAD CUT-OFF OF D. L. & W.

## Second Article on this Improvement Work Describing the Largest Concrete Arch Bridge in the World and Other Structures.

The unusual operating economies which will be effected on the Delaware, Lackawanna & Western by the expenditure of about \$12,000,000 for replacing 40 miles of line between Clark's Summit, Pa., and Hallstead, and the interesting features of the heavy grading and tunnel work now under way on this section, were described in the *Railway Age Gazette* of November 14, 1913. The present article takes up the bridge work that has been done on this line up to the present time, dealing only with the substructures of the two concrete arch viaducts which are exceptionally large and will require a considerable time for their completion. When the superstructures of these bridges have

except where the available clearance is not sufficient to permit the use of an arch or reinforced slab, or where the foundation is of such a nature as to make it inadvisable to use a concrete structure.

All structures were built to the same standards and specifications that were used on the Hopatcong-Slatford cut-off (see *Railway Age Gazette* of December 6, 1912, and January 3, 1913), except that cement is required to leave not more than 22 per cent. on the 200 sieve and to pass the auto-clave test. This test is carried out as follows: Six neat briquettes are made in the usual manner and placed in a damp closet for 24 hours. They

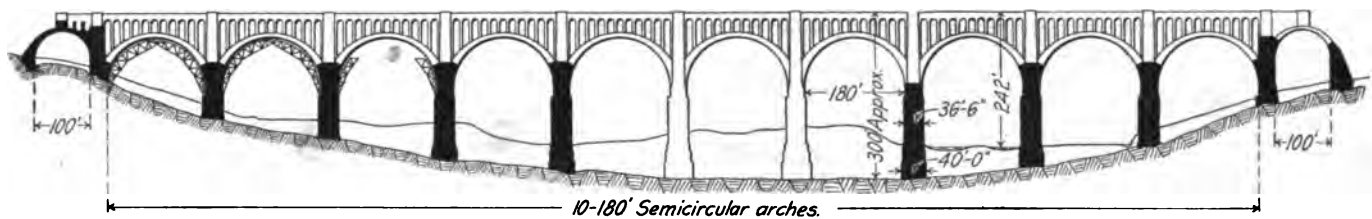

Elevation of Nicholson Viaduct, Showing Progress to November 1.

been sufficiently advanced, another description will be presented covering the design of the entire structures and the contractors' methods as developed during the course of the work.

The two concrete viaducts over Tunkhannock creek and Martin's creek will require about 167,000 and 78,000 yds. respectively, and the minor structures which are about 80 in number, will require 155,000 yds. of concrete, making a grand total of 400,000 yds. exclusive of tunnel lining and other minor quantities. All highways on the new line are carried either over or under the new grade. The elimination of these 22 grade crossings was an important consideration in making the improvement, as all of these would have required elimination in the not very distant future. All structures carrying the roadbed will be of concrete

are then removed and three of them broken in the standard tension machine in the usual manner. The other three are placed in an auto-clave, heat applied, and the pressure gradually raised to 295 lbs. in 1 hour. This pressure is maintained for 1 hour and then gradually released. The briquettes are taken out, allowed to cool and then broken in the standard machine. The average of the three briquettes taken from the auto-clave shall show an increase in tensile strength of at least 25 per cent. as compared with the average of the three briquettes tested in the usual manner.

### TUNKHANNOCK VIADUCT.

The Tunkhannock creek structure is 2,375 ft. long, end to end, of masonry, and 242 ft. from top of coping to stream bed,



General View of Tunkhannock Viaduct Location, Showing End Tower and Operator's House of Material Cableway in Foreground





Looking Along Center Line of Tunkhannock Viaduct In Early Stages of Construction.

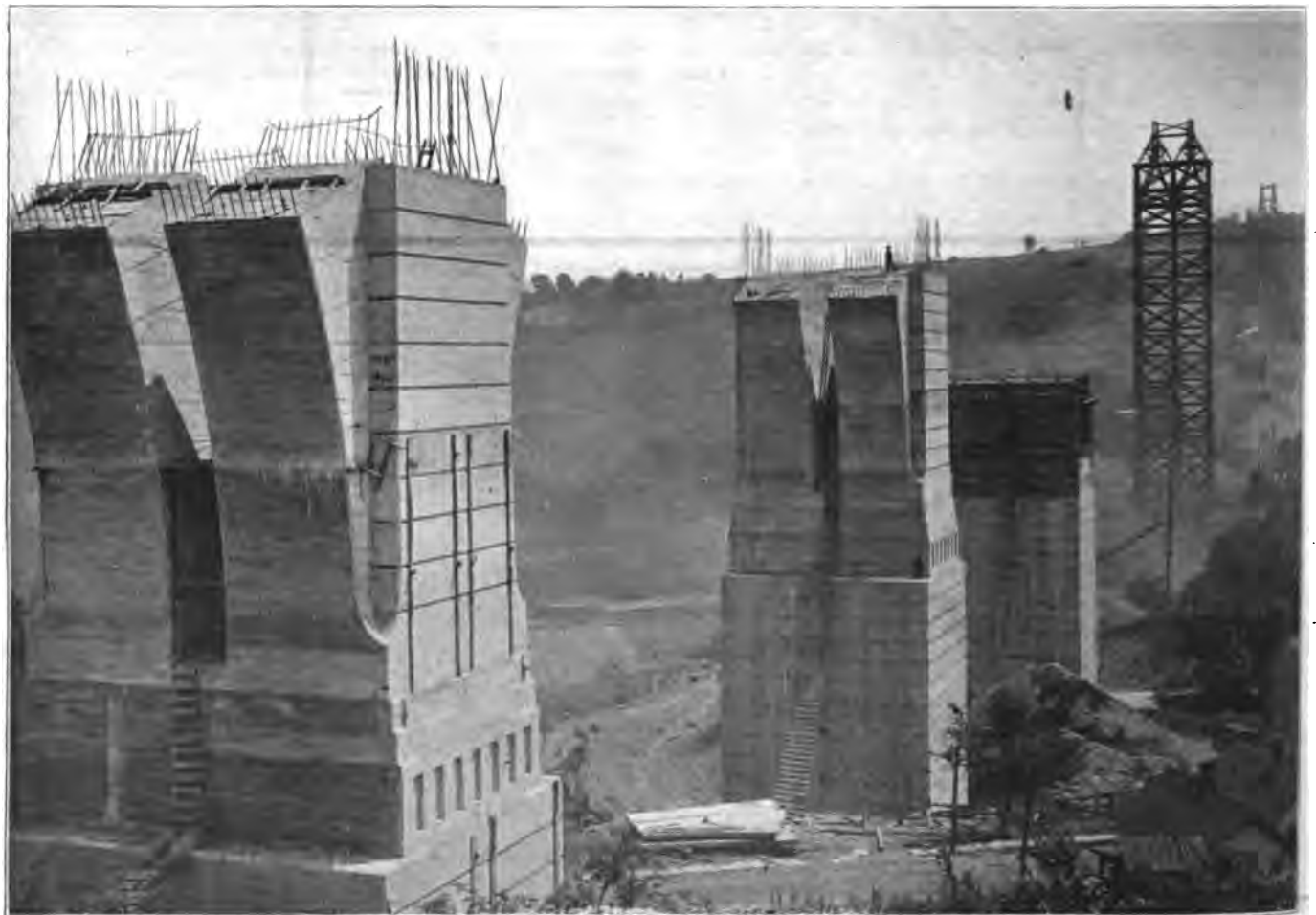

Two of the Tunkhannock Viaduct Piers with Umbrella Sections Completed.

which will be the largest concrete arch bridge in the world. It is composed of ten 180-ft. semi-circular intermediate arch

in the end embankments so that they will not be apparent after the work is completed. This viaduct will contain approximately 167,000 cu. yds. of concrete, 2,275,000 lbs. of reinforcing steel and will require the excavation of 43,500 cu. yds. of material for the foundation.

The piers are 36 ft. 6 in. x 43 ft. 6 in., and are solid below the springing line. The higher piers are 40 ft. x 46 ft. below the ground line, and all piers are carried down to rock, which is reached at a depth of 10 to 95 ft. below the ground surface, making the difference in the elevation between bed rock and top of coping at the deepest piers about 300 ft. With the exception of the abutments, one pier at each end and three other piers,



Showing Sectional Pier Forms and Double Cableway.



Looking Into One of the Pier Forms, Showing Reinforcement and Form Bracing.

spans and two 100-ft. semi-circular abutment spans, being designed to carry two tracks. The abutment spans will be buried

the foundations were excavated down to water level or to rock by a Model 40 Marion steam shovel, using a one-yard dipper. The material encountered was sand and gravel and was allowed to take its natural slope. In most cases the shovel was allowed to cut its way from pier to pier, and the material was used in filling under the temporary material tracks. The abutments and four piers were built in open excavation without sheeting. For the other piers, interlocking steel sheet piling were driven by a steam hammer. The deepest foundations required two lengths of 30 ft. sheeting, the upper set being driven 4 ft. 6 in. outside the lower to give clearance for the hammer and leads. The inner set was driven first and the excavation carried down with the driving. When the outer set was started both were carried

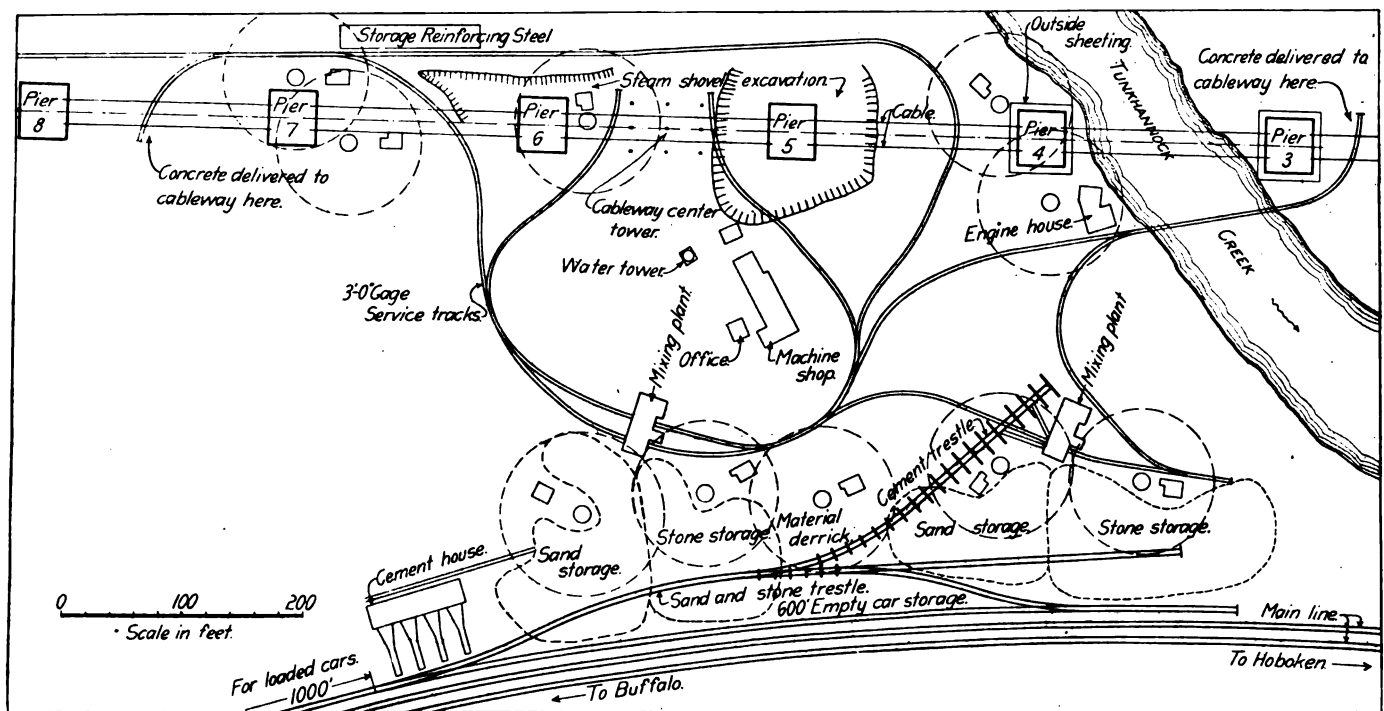

Arrangement of Contractor's Plant at Tunkhannock Creek Viaduct.

down together, the bracing for the upper set being entirely above the tops of the lower piles so that there was no interference between the two sets of bracing.

The soil through which these cofferdams were driven was largely wet sand, making the pressure unusually high on such deep excavations. Considerable trouble was experienced in one of these deep piers on account of the shifting of this pressure, causing damage to the piles and allowing water to enter. The material was removed by clamshell buckets, some boulders being removed by hand.

In placing concrete after excavation was completed to rock

37 ft. above the springing line of the arches will be considered at this time. The piers have a 4-ft. offset on each side at an elevation 17 ft. 6 in. below the springing line to support the arch centers, but the 37-ft. section above the springing line is built as a part of the piers, this so-called "umbrella" system being similar to that used on the Delaware river bridge of the Philadelphia & Reading, described in the *Railway Age Gazette* of April 25. The forms used on the bodies of the piers are built up in ten sections 17 ft. 9 in. high in which a 16 ft. lift is made. These sections can readily be handled by the derricks and are used a number of times. The framing of these forms is of 8

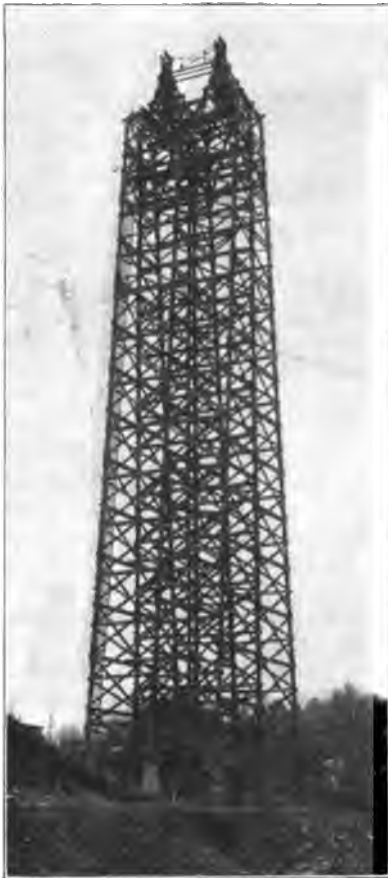

Framed Tower 260 ft. High for Center Support of Material Cableway.

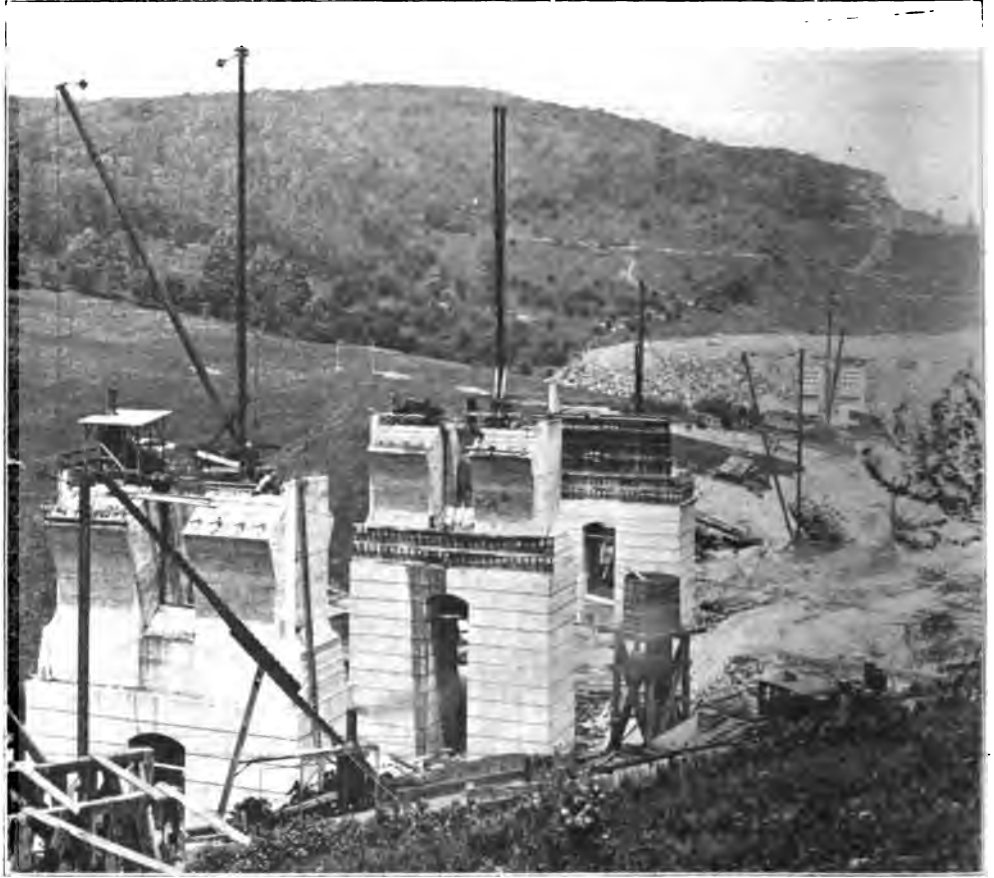

Partially Completed Piers of the Martin's Creek Bridge. The Umbrella Forms Are In Place on the Third Pier.

the water collected in the cofferdam was carried around by a timber drain to a sump in which pumps were placed to remove it. No concrete was placed under water. The footings up to the bottom of the neatwork were placed without forms, the entire cofferdam being filled with concrete up to this level after tar paper had been placed against the steel to prevent the bonding of the concrete to the piles. In order to pull some of the sheet-

in. x 10 in., and 6 in. x 8 in. timbers, with two diagonal layers of 1 in. sheeting, faced with galvanized sheet iron. The inner faces of the forms are provided with strips of molding at 4 ft. intervals to form the horizontal scoring on the shafts of the piers. A system of 3½ in. x 3½ in. angles is used for bracing the forms. These angles are set in the concrete after every lift of 4 ft., and are fastened by bolts in the next lower lift which

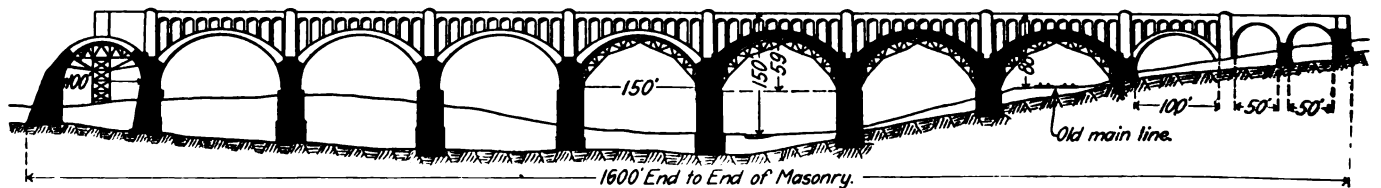

Elevation of Martin's Creek Viaduct, Showing Progress to November 1.

ing an eight-part tackle hung from an "A" frame supported on the foundation concrete was used which made it possible to apply a force of 40 tons. The neatwork up to the ground level was placed in rough cribwork forms.

Only the substructure work which extends up to a point about

are attached to the bent ends of the angles. Each form section is held in place by three sets of these angles, the connection being made by short rods attached to the angles by turnbuckles. The angles are placed diagonally from all faces so that a firm bond to the body of the concrete is secured.

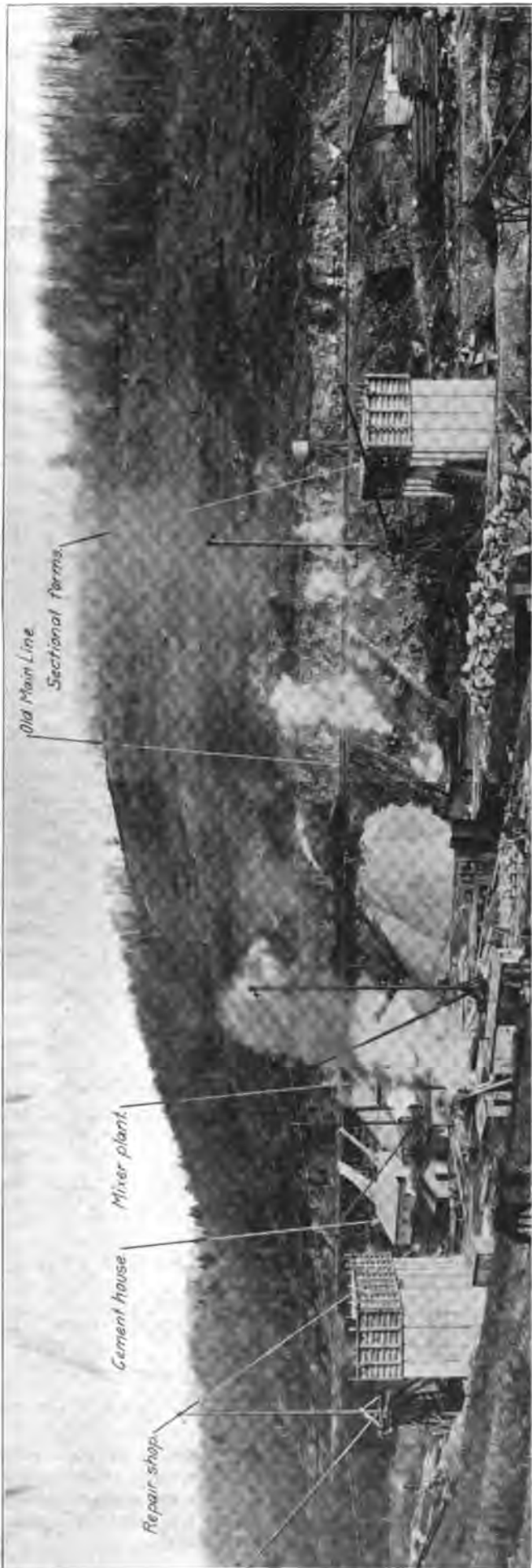

General View of Martin's Creek Viaduct Site Showing Contractor's Plant.

The material is being handled by a combination of derricks and a double cableway over the center line of the bridge. The cableway is supported on three framed towers, and is composed of two 2 1/4-in. cables placed 20 ft. center to center. The end towers are 3,028 ft. apart, and are 150 and 165 ft. high respectively. The center tower is 260 ft. high and 40 ft. x 60 ft. at the bottom, dividing the cableway into four independent operating units. The cables are designed for an average working load of seven tons and a maximum load of 10 tons. An operator's house with two independent hoisting engines is located back of each end tower, one of these being shown in the foreground of the accompanying photograph. The construction of this cableway in itself is an unusual feature of the work. The total length is thought to be the longest ever attempted for cable operation, and the height of the center tower the greatest ever used to support a cable. The complete cable equipment was installed by the Lidgerwood Co. It will be necessary before the completion of the superstructure, to add a section on the top of the center tower, this addition being provided for in the design. On account of the distance between the operator's house and the points of loading and unloading the cables, it was found necessary in order to operate successfully to install a complete telephone system so that the operators could receive all signals from the men at the loading and dumping points by telephone. The operators are provided with head sets, which allow the free use of both hands for operating the engines.

The contractor's plant is complete in every detail and is carefully designed to allow the most economical handling of material. All material is delivered on a 1,600 ft. side track adjacent to the old line, which is about 300 ft. from the new bridge. As an indication of the amount of material handled by this plant, 635 cars of material have been delivered to this siding in a single month. The sand and stone which are brought in bottom dump coal cars are dumped into storage piles from a material trestle about 30 ft. high. A 4,000-bbl. cement house with four covered chutes is provided for the storage of cement for mixing plant No. 1, and a trestle is carried out to plant No. 2, which allows the cement to be handled directly from cars. Derricks operating clamshell buckets are located at convenient points between the storage piles and cement house and the mixing plants to elevate the sand, stone and cement to material bins or the charging floor.

The two mixing plants are duplicates and are housed in frame buildings 40 ft. high, allowing the operation of narrow gage cars carrying concrete buckets directly under the mixers. Each plant has a capacity of about 40 cu. yds. per hour. The charging hoppers over each mixer are bulkheaded vertically to separate the sand and stone, a system which has proved much more effective in the proper proportioning of the materials than the horizontal gage lines frequently used. The cement is distributed evenly over both the sand and the stone. Cube mixers receiving water through the main trunnion are used. The plant is carefully designed as to all its details, the provision for inspection, for instance, being so carefully arranged that one man standing near the charging hopper can watch the proportions in the hopper, the water gage and all the points which should come under his attention. Live steam is piped to the material bins for use in freezing weather.

Each of the mixer plants is designed to serve half of the structure, but the track layout is arranged so that the output of either plant can go to any point on the bridge. The concrete is taken from the plants in 2-cu. yd. bottom dump buckets carried on 3-ft. gage flat cars propelled by dinky locomotives. These locomotives deliver concrete either to derricks located near the piers or to the cableway, a number of tracks having been laid out for the purpose of delivering these buckets to the cableway at convenient points. The general layout of the contractor's plant is shown in the accompanying drawing.

Three grades of concrete known as "A," "B" and "Cyclopean" are used in this structure, class "A" being a 1:2:4 mixture.

which is used on very thin heavily reinforced walls; class "B" is a 1:3:5 mixture, which is used for the arch rings, floor system, and all work above the springing line, except where class "A" is specified; "Cyclopean" is the same mixture as "B," with large derrick stone bedded in the concrete, and is used in most of the work below the springing line. This work, which is being handled by Flickwir & Bush, New York, was begun about August, 1912, and more than 85 per cent. of the foundation excavation has been finished, and more than one-third of the total yardage of concrete placed.

#### MARTIN'S CREEK VIADUCT.

The bridge over Martin's creek is about 1,600 ft. long and is being built for three tracks. The top of rail on the new structure is 150 ft. above the bed of the stream and 88 ft. above the old tracks. It is composed of two 50-ft. and two 100-ft. semi-circular arches, and seven 150-ft. by 59-ft. three-centered arches. The structure is similar in general design to the Tunkhannock bridge, and will require about 27,000 cu. yds. of foundation excavation, 78,000 cu. yds. of concrete and 1,600,000 lbs. of reinforcing steel. About 85 per cent. of the foundation excavation is completed and nearly one-third of the concrete is in place.

The main piers are solid for 17 ft. below the springing line and below that elevation they are divided into two legs 23 ft. by 28 ft., separated by a 12-ft. opening. All piers are built on solid rock, which is reached at an elevation varying from 10 to 60 ft. below the ground surface. A steam shovel was used to excavate these foundations down to the water line, and Lackawanna sheet piling were driven by a 6,000-lb. Vulcan hammer below the water line.

The contractor's plant for this structure is almost identical with that in use at the Tunkhannock viaduct, except that no cableway is used, all material being handled by trains and derricks. Two sidings are provided along the old line opposite the new bridge, one over the storage piles and one which is used for holding cars temporarily. A 3,000-bbl. cement house with two chutes is provided near the sand and stone storage piles, as shown in the accompanying photograph. The mixer



Contractor's Layout for Arch Under Smith Fill.

plant, which is a duplicate of the ones used at Tunkhannock, is located near enough to the storage piles to be served by derricks. On account of the number of narrow gage tracks around the mixer plant the contractor installed an eight-lever interlocking plant to handle all switches in these tracks. One man located on a platform raised slightly above the track level handles all the switches more easily and more rapidly than if they were hand thrown, and on account of the large number of movements that are made over these tracks the machine is an important safety factor.

For the early stages of the piers all material was handled by derricks located in each span. After the completion of the umbrellas on the base of the piers, derricks will be erected on

top of this masonry which will be allowed to remain there to handle the concrete for the superstructure. A saw mill, a complete machine shop and a power plant for generating electric light are included in the contractor's layout. This work is being handled by the F. M. Talbot Company, New York.

#### OTHER STRUCTURES.

The 30-ft. roadway arch under the Smith fill was handled in a manner typical of a large part of the concrete work on the minor structures. The concrete plant was located on the north side of the arch, all materials being brought in by narrow gage cars to the top of the adjacent fill, from which they were chuted down to the storage bins above the mixing plant. Four der-



A Typical Highway Undercrossing.

ricks, two with 78-ft. and two with 68-ft. booms, were located back of the north abutment and were used for handling the concrete from the mixing plant, and also for handling the Blaw steel forms. The  $\frac{3}{4}$ -yd. mixer dumped into 1-yd. buckets carried on small flat cars, which were run out on a short section of track from the mixing plant to the edge of the arch excavation, where they could be reached by the nearest derrick. To place the concrete in the ends of the arch the center derricks had to swing these buckets out to a point from which they could be reached by the end derricks. In this manner this plant is able to place about 275 yds. a day. The forms were placed 5 ft. center to center, and  $3\frac{3}{4}$ -in. lagging was used. The form work was erected in 50-ft. sections, and the concrete was poured in sections 40 ft. long. In turning the arch, from 10 to 12 hours were required to pour one of these sections.

The concrete arch which carries a highway under the Riker fill was shown in the photograph accompanying the former article. The materials for the arch were brought in on the old line and carried up from the siding on a narrow gage incline, across the new line, and out over the new location of the highway on a trestle, which allowed sand and stone to be dumped to the storage piles. The mixing plant is located adjacent to those storage piles and the derricks shown in the view were used to place the concrete in the arch. At Alford on section No. 9 a double culvert was adopted carrying a roadway and waterway under the line in a single structure. The roadway occupies a 24-ft. arch and a 4-ft. by 6-ft. culvert below the roadway provides for the stream.

The entire work of building this cut-off was planned and is being executed under the direction of G. J. Ray, chief engineer. F. L. Wheaton is engineer of construction in immediate charge of the work, and A. B. Cohen, concrete engineer, is in charge of the masonry designs.

**CAR LIGHTING IN JAVA.**—In Java railway trains are not operated at night; that is, from 7 p. m. to 5 a. m. Therefore very little provision is made for lighting passenger coaches. An acetylene plant has recently been installed, however, at Bandoeng, which has a capacity of 15 tubes per day, compressed to 220 lbs. per sq. in.; and acetylene lighting apparatus is being substituted for oil lamps in the cars of the through trains.

# INSIDE SHEATHED STEEL FRAME BOX CARS.\*

Care Necessary in the Selection and Treatment of Lumber  
for Sheathing; Corrugated Metal a Successful Substitute.

By R. W. BURNETT,

General Master Car Builder, Canadian Pacific, Montreal, Que.

The original wooden car, with the single spring draft rigging having the cheek castings bolted to the sills, gave little if any more trouble than modern equipment, due principally to the shorter trains, less density of traffic and to the use of link and pin couplers which compelled gentler handling of trains than is prevalent today. The steel underframe car was built mainly to secure a stronger center construction for the attachment of draft rigging and to get away from the trouble caused by wooden sills breaking and splitting, broken draft bolts, etc.

While having many advantages over the old wooden car, the steel underframe car developed some troubles peculiar to itself, the most important being due to the fact that the body being carried on a rigid frame and not held together by the strains resulting from its weight, as in the old trussed cars,

several times. All of these, however, were outside sheathed and as regards leakage at the sills, had comparatively little advantage over the wooden cars. Recently both of these lines have purchased some inside sheathed cars. The Frisco car of this type is fully described in the *Railway Age Gazette*, October 3, 1913.

In 1908 the Canadian Pacific designed its first steel frame inside sheathed box car. This car avoided the disadvantage of the outside sheathed car, and at once obtained a further reduction in weight and provided for cheapness of maintenance by the use of steel superstructure without the additional lumber required by the outside sheathed car. With practically no preliminary experimenting 500 of these cars were built, and since then over 30,000 have been built similar to the first cars, with



Canadian Pacific Steel Frame Box Car with Corrugated Metal Sheathing.

has a tendency to develop slack in the superstructure. This in turn affects the roof and sheathing. One principal trouble with outside sheathed cars is that, after they have been in service a comparatively short time, the sheathing frequently loosens at the end sill and at the side sills near the bolsters with resultant leakage of grain.

There were some steel frame box cars built previous to 1909, but the writer has been able to secure data on only the outside sheathed types. Of these 2,700 were in service on the Norfolk & Western, of which the first 100 were built in 1902; the owners state that they were satisfactory and the same type has been purchased on subsequent orders. The Rock Island and Frisco lines had in service at that date approximately 5,000 cars similar to the Norfolk & Western, and these also appear to have given satisfaction as the owners have reordered the same type

the exception of several refinements of details, such as corner and door posts, end doors and side plates, and the joining of flooring and lining. These changes have not affected the general design of the car, but are the improvements that have been introduced from time to time to reduce weight and simplify the construction.

#### ADVANTAGES OF THE STEEL FRAME CAR.

The steel frame inside sheathed car has several advantages over the types previously used, notably in that the tare is low in proportion to the capacity. There is such a variation in the figures used for the cost of hauling per ton mile, that no attempt is made to say what the saving would amount to, but certainly the advantage of having a car equal, if not superior to other cars in all respects, and weighing from 1,000 to 5,000 lbs. less, will appeal to all traffic and operating men. Not only is there that much less dead weight to haul when the car is empty or partly loaded, but additional lading can frequently

\*Extracts from a paper read before the American Society of Mechanical Engineers at the annual meeting, December 3, 1913.

be carried. The actual limit on the paying load that can be carried in a properly designed car is the total weight on the axles. Thus, a car having 5 in. x 9 in. axles with such a tare weight that, when deducted from the capacity of the axles, allows the car to be safely loaded to 88,000 lbs. could, if dead weight be reduced by 3,000 lbs. safely carry a paying load of 91,000 lbs. and retain the same strength. Thus the actual capacity of the car is increased almost 4 per cent., with a better ratio of paying to dead load.

It had been thought necessary to assist the wooden type of superstructure by heavy roof construction, some going so far as to use different methods of diagonal bracing, but with the steel car it has been found that there is no appreciable local movement of the framing in the heaviest service which makes a simple proposition of the roof as it has only to take care of

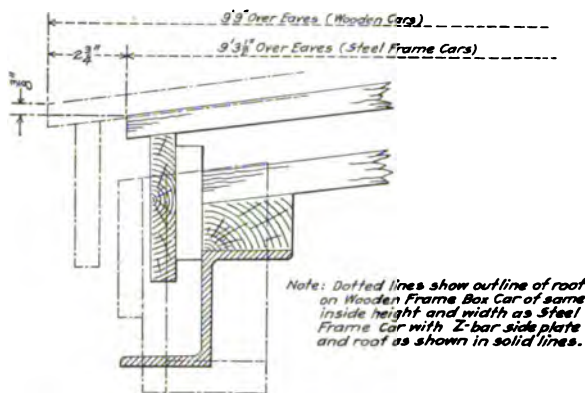

Roof Clearances on Steel Frame and Wooden Box Cars.

itself. This presents a simpler problem to roof designers, making it possible to design a roof much lighter, without necessity for the use of purlins or ridgepoles to strengthen the car. It is obvious that unnecessary weight in the roof raises the center of gravity, increases the tare weight and cost and has other disadvantages.

In explanation of the local movement of this style of framing, it is well to mention tests we have made in jacking up this type of car, which demonstrated that the car would take a gentle twist from end to end, allowing the bolsters to be slightly out of the same plane horizontally. This twisting was accomplished without any perceptible local distortion of the sides or ends. The capacity for twisting is a condition to be desired as it allows a car to adjust itself to uneven track conditions.

In addition to being 5½ in. narrower than the distance over the outside of the sheathing of a wooden car, the superstructure of the Canadian Pacific car is protected by the framing, so that a side swipe that would do serious damage to an outside sheathed car frequently does not touch the lining and is resisted by the framing without damage to the posts or braces. Frequently it is found that a side swipe that would almost demolish the sides of a wooden car only bends the steel framing, and in making repairs, the lining is merely removed, posts and braces straightened and the original lining replaced, the whole cost being the comparatively small labor charge. Jacking frames are being installed at all of our principal repair points for all classes of steel cars, and while not original with the Canadian Pacific, they have been amplified to better take care of steel frame box cars. With these frames, many jobs that would require the car to be cut apart, taking several days, can be done in a few hours without cutting the rivets. With modern steel frame cars, these jacking frames are as much a necessity as the blacksmith shop or any other part of the shop.

It is difficult to clean an outside sheathed car properly when it is unloaded, on account of grain lodging between the framework and also on account of the opening where the posts and braces meet at the bottom becoming obstructed, resulting in grain being retained between the sheathing and lining with

resultant complaints from shippers. All of this is overcome by the clean joining of the lining and the floor in the steel frame cars, and it is believed a change of this kind would have come years sooner if designers had kept in close touch with service conditions. One advantage of the steel frame car is that outside of possible repairs due to wreck damage and to wear and tear of couplers, wheels, brake shoes and journal bearings, the car does not deteriorate more rapidly in service than when stored.

#### SELECTION AND TREATMENT OF LUMBER.

The grading of lumber for use in these cars is an item that has received much consideration. Yellow pine or fir has so far been the principal lumber used, although we have experimented to some extent with spruce, but although it has the advantage of being lighter, it seems to be more difficult to dry spruce sufficiently for this purpose. Great pains have been taken to avoid knots that are too large or numerous, and while it is generally desirable to have lumber as free from knots as possible, I have never in the inspection of many hundreds of cars seen where a knot had fallen out. It is, however, desirable to have lumber as free from sap and shakes as possible and thoroughly dry.

When the first of these cars were built outside of the Canadian Pacific shops we had considerable difficulty in getting the lumber properly dried, due to lack of both experience and facilities on the part of the car companies. We have about 3,000 cars on which the lumber has shrunk and given them a bad appearance, but this result was expected, as when the cars were built the lumber was quite green. The sheathing on these cars could be tightened for less than \$4 per car, but very few have been tightened, owing to receipt of practically no reports of loss or damage to lading due to the shrinkage; also as they do not frequently reach our main repair tracks, being shopped only for such repairs as wheels or wreck damage, we have not considered it advisable to shop the cars for a defect which is

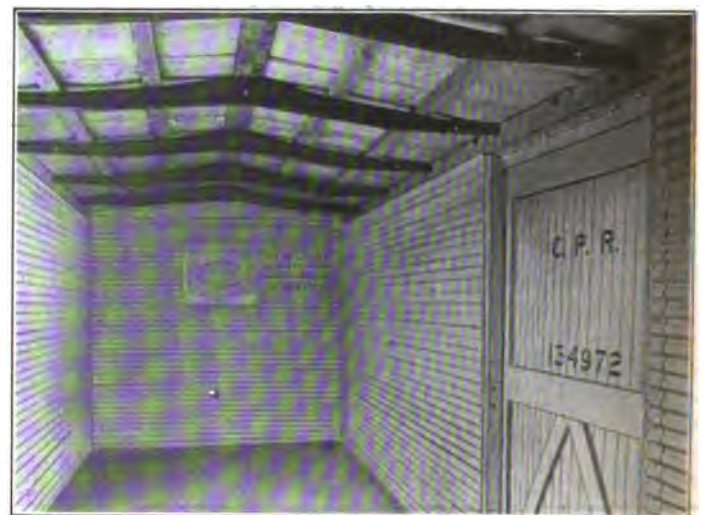

Interior of Steel Frame Car with Inside Corrugated Metal Sheathing.

almost entirely a matter of appearance. The lining shrinks as much in two months of summer weather as it ever will.

The lining should not be matched before drying, as it warps and curls, rendering it difficult to make a tight joint. The rough size of lumber should be at least ¼ in. greater than the finished dimensions. In establishing limits for drying lumber no information or data whatever could be secured, and after experimenting we came to the conclusion that a piece of this lining of full cross-section subjected to a temperature averaging 170 deg. F. for 96 hours should not lose more than 6 per cent. in weight and that lumber represented by samples losing more than 10 per cent. must not be used until further dried.

## DEVELOPMENT OF A STANDARD CAR.

The development of the inside sheathed car has been so rapid and the experience with it so uniformly satisfactory, that I feel safe in saying that its introduction in such large numbers on so many roads in so short a time indicates more nearly a tendency toward the adoption of a standard car than has any distinct type of car outside of patented cars for special service. It is certain that there will be no backward movement to a wooden superstructure, and that this car with possible modifications will remain a standard car unless some superior type of car is developed. It is the writer's opinion that no committee will ever develop a car that will be adopted as standard, but that the nearest we will ever get to a standard is what may be developed by one or two persons given a free hand, and the merit of which is so pronounced that it forces itself upon the country.

With the use of structural steel there is less necessity of carrying special parts in stock on account of repairs being largely a question of labor, and it seems that with this type of car the necessity from a repair standpoint for a standard car is decreasing. This is further borne out by the fact that for the 30,000 new cars of this type we have ordered no material for repairs and carry none in stock outside of material common to all cars, except lining; of the lining, our stock amounts to practically nothing. We save out sufficient of the parts from cars destroyed to make up our stock of repair parts, but have found it necessary to use very little of this. There are, of course, many valid reasons why cars should be made to standard inside dimensions and outside clearances.

To look at the matter in another way, the wheels, axles, journal bearings, journal boxes, couplers, brakes, safety appliances, etc., which constitute the removable and perishable parts, are all standard and when it is remembered that nearly all of the remaining parts of the cars are standard rolled shapes which are easily obtained either from the mill or from stock in all principal cities, it is apparent that we now have, in effect, a standard car or at least a car of standard parts. A car of different dimensions would not increase the cost of maintenance as long as standard shapes are used; nor would it if every lot of cars is designed differently, as long as proper strength is maintained, and any change in design would usually be to increase the strength. In other words, to keep a car as close as possible to standard and reduce the cost of maintenance, rolled shapes should be used in preference to pressed shapes where possible.

It is my belief that the people who are urging the adoption of a standard car for maintenance reasons have in mind the remaining wooden cars for the maintenance of which large quantities of timbers and castings have to be kept in stock. It is of vital importance that the parts be standardized if that style of construction were to be continued. It should not be overlooked that in a car constructed with rolled shapes, these parts seldom need renewal, even when the car is wrecked, as they can easily be straightened or formed to the original shape at any car repair point, while wood would have to be replaced and pressed shapes would call for special dies to reform them. With a wooden box car the amount of material necessary to carry in stock and use for repairs increases rapidly with the age of the car, while with a steel frame box car, outside of parts common to all cars, it does not increase.

## WIND RESISTANCE.

The wind resistance on the steel frame box cars with inside sheathing is slightly greater than on a smooth outside sheathed car, but on the other hand, it is less than on any ordinary type of stock car. The difference in the effect of wind resistance between box and stock cars has never been great enough to require any distinction between them as to the number of cars that could be hauled in a train of either, and is really a refinement that not even a dynamometer car can detect. A small

change in the angle or velocity of the wind, trucks somewhat out of square, etc., affect the haulage of the train too much to enable any satisfactory figure for the difference in the wind resistance of the various types of cars to be determined. As compared with outside sheathed cars the wind resistance of the inside sheathed, steel frame box car may quite properly be ignored.

## CORRUGATED STEEL LINING.

In the summer of 1911, we lined a steel frame box car with corrugated steel and found it to be as simple a matter as lining with wood. We lapped and riveted the sheets, which were No. 13 gage, between the door and end, and had the corrugations on the side and end coincide, pressing into special corrugated angles in the corners to break the joints. At the floor, we straightened out about 4 in. of the corrugation and formed of it an angle that rests on the side sill, and on this the ends of the floor boards were superimposed, making a very tight joint. After 18 months of general service this car was brought in and on examination found to be in as good shape as when constructed. It was interesting to note that when inspected, the paint sealing the joints where the side sheets lapped was in no place seal broken, indicating that there is no material weaving or deflection of the sides. The paint was in perfect condition, there still being some gloss, indicating that in the use of steel there is no disadvantage as far as the painting is concerned. Different methods of lining with steel could be followed, and I am convinced that if experience proves that there is no damage to be feared from heat, cold or sweating, steel lining will be largely used. But, I am also convinced that the use of steel lining with any insulation will never be extensively used, as it adds to the cost and weight without affording any protection to the lading, which is not secured by the wood lining.

## END CONSTRUCTION.

In the end of the car we use two 4 in. Z-bar end posts of 8.2 lbs. per ft., with 1¾ in. lining, which gives good service, but we intend to use on future cars two 5 in. end posts of 11.6 lbs. per ft., with 2¾ in. lining for a height of 4 ft. and 1¾ in. lining above. This, we feel, will amply protect any lading. If a car gets such rough handling that wheels, rails or similar lading would break through, it is better to have the boards broken than to distort the posts, as the lining can be replaced at any repair track with a minimum expense, while distorted posts would require sending the car to a steel car repair point. The single thickness end lining makes convenient the application of single thickness, grain-tight end doors.

## SERVICE RESULTS.

Out of 30,000 of these cars, 29 have been destroyed. Based on the length of time in service, this would average a loss of approximately one car per 1,000 per year. Of the cars destroyed 15 were burned and 14 were destroyed in wrecks, 10 cars being destroyed on foreign lines. As the loss of cars by fire is in no way affected by the details of construction, I will eliminate them from the calculations. This then, based on the length of time in service would give about one-half car per 1,000 per year destroyed in wrecks.

A conservative estimate shows that there are now in service approximately 65,000 steel superstructure cars, including those of the outside sheathed type, and of this number 30,000 belong to the Canadian Pacific.

OPENING A SYRIAN RAILWAY.—The Hedjaz Railway inaugurated the branch line from Haifa to Acca on October 14 by sending a free train to Acca with Haifa people. After the inauguration celebration at the Acca station, the train left with Acca people for Haifa. In the evening a train took the Acca people home and in return brought the Haifa people back from Acca.





In Section 11 it is shown that the location of a passenger terminal for the Pennsylvania Company and its associated roads on Canal street, south of Twelfth street, is not impracticable, and if this company would now see fit to locate at this point, the previously described plan could be at once adopted, and the solution of the passenger terminal problem of the city would be much simplified, because all the other railroads, with the exception of the Chicago & North Western, could then probably be easily induced to finally locate in the new Illinois Central station on the lake front, or with the Pennsylvania Railroad company in its Twelfth street location, and thus make it unnecessary to ever construct any more passenger stations in the business district between Michigan avenue and the river. But, in my judgment, such a location would be unfair to force upon the Pennsylvania company unless other competitive roads and those other roads now having passenger stations north of Twelfth street, agree to join it in a new station or enter the Illinois Central station, for the reasons that such enforcement, would compel the Pennsylvania company to give up its present advantageous location and recede to a point the most distantly located from the business center of all the roads, and be still further handicapped by not only having to cross the river, but also be located in a district now inaccessible.

Furthermore, it is not at all clear to me that the business interests of the city would now be served best if the Pennsylvania and its associated companies now moved their station south of Twelfth street, as this location would unnecessarily inconvenience the many patrons of the present Pennsylvania terminal for some years, with little or no advantage to be gained during the years that it would take to build up the territory between Harrison street and Twelfth street so as to make the Twelfth street site a desirable location.

For these reasons it seems to me that if the Pennsylvania company would agree to locate its passenger station with the headhouse just south of Harrison street, that its interests would be fully conserved, as this location would make its accessibility to the present business district no more advantageous than a Twelfth street location of the other roads would be should they move back, due to the ease with which this Twelfth street location could be reached (if Twelfth street and Canal street are boulevarded) as compared with the hardship of being compelled to cross the river to reach the Harrison street site, something that many of the patrons of the Pennsylvania company must now do and continue to do so long as its station is west of the river. By thus moving back the company would not only get space desirable for the expansion of its passenger station, but would also at the same time be making a concession to the other railroads, which ought to result in their co-operation toward carrying out a terminal plan that should in the end prove satisfactory to the city.

If the Pennsylvania company will not now make this concession to the other roads, and insists upon building at Adams street, it should be required, if allowed to build now, to confine itself to the construction of a station adapted to the location, without crossing the river, which could be used by itself and its associates for some years, and at the same time agree that when the capacity of this station is reached, and at any event within a fixed period of years, unless some method of through routing of main line trains shall have been adopted, to abandon the use of this station for its main line through passenger trains and recede to a new terminal at Twelfth street, west of the river, if it so elects, or, preferably, east of the straightened river, thus avoiding crossing the river at all; *provided*, a co-operative agreement has been reached between the different railroad companies of the city for straightening the river, wherein all roads not naturally belonging west of the river, agreed to recede from the present business district and use either the Illinois Central station, or the new station above suggested, and failing in this, place their passenger stations south of Twelfth street. The Pennsylvania station thus released could then be used exclusively by the Burlington, the Chicago, Mil-

waukee & St. Paul, the Soo line, the Chicago Great Western, and possibly the western division of the Illinois Central.

If the Adams street plan, as recommended by Mr. Wallace, is now adopted, provided the fundamental conditions herein recommended are agreed to, it will not necessarily prohibit the future development of other stations between Canal street and the river south of Adams street, or on the *co-operative unit* principle in general accordance with the Guenzel and Drummond and Pond and Pond idea. And further if this co-operative unit plan fails entirely of adoption there still remains the opportunity for the development of *individual stations* along Canal street and south of Twelfth street. In the latter case the most logical solution for the Pennsylvania company, if it decides to recede with its main terminal, and such other companies as do not arrange to occupy the Twelfth street station of the Illinois Central Railroad Company, would be for them to build eventually, one or more terminal stations east of the straightened river, and south of Twelfth street.

In case the above plan, involving the use of stub stations or other terminals which would stop all through passenger trains at Twelfth street, should be adopted, there would then be no good reason why the present La Salle street station should not be retained in service and utilized as the suburban terminal of such eastern, southern and southwestern roads as use these Twelfth street terminals for through passenger trains, provided the tracks leading to the La Salle street station were placed under ground and covered north of Twelfth street. It would also be possible to extend two tracks northward under La Salle street, separating around the Board of Trade building, thence through the present La Salle street tunnel to a connection with the east and west subway on Ontario street hereinbefore referred to; thus providing high speed suburban service directly through the center of the entire business district.

Again, while I believe that the Harrison street location would be better for the railroads and the city, I am not so sure that the retention of the present Adams street site by the Union Station Company, and the grouping of its terminal with that of the North Western railway, approached from the east by an opened and possibly widened Monroe street (from La Salle street, west), would prove a detriment, or in reality result in a deterring factor in preventing the other roads from finally voluntarily receding from the business district, for this arrangement would in effect be placing one of the main terminals referred to in my preferred plan at this location though divided into two small terminals. Furthermore, the development of the business district southward, will in time make the Twelfth street location, if Canal street and Twelfth street are widened and boulevarded, so desirable a location for the other roads that they may not consider that the Pennsylvania company then has the advantageous location with reference to the business district that it now seems to have.

Thus, in case of absolute failure on the part of the city to get the roads to co-operate in the construction of union terminals, these roads now having terminals in the center of the business district may, for their own protection, as they need additional passenger facilities, either join the other roads as previously outlined, or construct new terminals south of Twelfth street, for none of these terminals is so located as to warrant reconstruction upon its present site, except for suburban or freight business, the probability of which is treated elsewhere.

#### STRAIGHTENING CHICAGO RIVER.

The most important improvement that probably could be made for the benefit of not only the city of Chicago, but also the railroads themselves, would be the straightening of the Chicago river from either Harrison or Van Buren street due north. By this change, drastic as it may seem, the entire congested district south of the present business district, and now occupied by railroad terminals, could be opened up and the freight terminals of the railroad companies rearranged in such a manner as to not only greatly improve conditions for handling freight, but it

would also in time make possible the construction of business blocks upon the sites of the present railway terminals, with the advantages of railroad terminal facilities underneath somewhat on the principle of those now underlying the large district north of the Grand Central Terminal in New York City.

While this class of improvement practically necessitates the electrification of the tracks, the suggestion is not made with the intention of attempting to force such electrification, as most all progressive steam railroad men now recognize that electrification of terminals must come within a reasonable time, and the further reason that this subject is now being analyzed, at the expense of the railroads, by the Committee on Smoke Abatement and Electrification of the Chicago Association of Commerce, whose report is promised for the near future, but only for the purpose of emphasizing the advantages that the railroad companies now possess for future development by the ownership of these sites, which development can ultimately be made, if properly done, without jeopardizing the interests of contiguous private property owners or the interests of the city of Chicago as a whole.

Furthermore, the straightening of the river would transfer from the west to the east side of the river, many acres of comparatively cheap property now lying west of the river, and by this change cause it to double or possibly treble in value, if it were properly developed, for it would then become a part of one of the most desirable localities of the business district. This increase is shown to be from \$7,750,000 to \$31,290,000, depending upon the location assumed for straightening the river and the relative increase of values assumed. Thus the expense of changing the river would not only be more than fully realized by the railroad companies who now own practically all of the abutting property on both sides of the river, as far as it is herein recommended to be changed, but they would also profit greatly by the change.

#### FREIGHT TERMINAL DEVELOPMENT.

With the river thus straightened, it would be possible to so develop and re-arrange the territory both east and west of the river, that the freight capacity and facilities of the railroad companies would be greatly increased, and thus make it possible to handle all the freight business that it is necessary to bring into and take from the business district of the city for many years, so that there would be no occasion now or in the far distant future for the acquirement of additional property for freight facilities in this district. As the business district extends southward these additional freight facilities would be more centrally located than they now are, thus better serving the extended business district as a whole than though this freight were concentrated in the present business district.

From every standpoint, whether the river is straightened or not, the available areas can be developed to such an extent as to make it unnecessary for the Pennsylvania company to develop the proposed new freight area in the manner set forth in its plans. And there is also ample space available for all the freight facilities needed by all of the companies, if they will pool their issues and develop the territory as thoroughly as it is capable of being developed, by using modern and efficient methods.

Chicago freight business consists of two general kinds: (1) through, and (2) Chicago destination or origin. This applies to both carload and less than carload freight.

At the present time inbound freight trains arrive at the various break-up yards located within the city limits where the freight is distributed, and practically one-half of the total inbound freight of the city is sent to connecting lines for forwarding to other points outside of the city, and about 70 per cent. of the half interchanged, or 35 per cent. of the whole, is brought into the downtown district and switched between the various lines, the remaining 30 per cent. of the half interchanged being handled by belt lines outside of the city. Thus about one-half the freight is for Chicago delivery, a large part of which comes into the down-

town district to be unloaded and distributed largely from the individual freight houses, or team tracks, of the companies, where those companies only deliver and receive freight for their own companies.

On first thought it would seem that there should not be so many individual freight houses, and that the complete adoption of universal freight houses (*i. e.*, freight houses where freight would be received for all roads and delivered from all roads) would be ideal, but on closer analysis this as yet seems to me to be impracticable and undesirable, and in this respect I do not fully concur with Mr. Wallace who, I judge from his report, appears to recommend that all houses be universal. There is no doubt but that the strong competition between the roads has resulted in the individual freight house idea having been carried to the extreme, but so long as individual road operation is carried on in the city there should be individual operation of freight houses to a certain degree. My conclusions are, that there should be at least one universal freight house in each main division of the city surrounding the downtown business district, and possibly more, but that this is one of the subjects that should require further study.

Summarizing the present situation as regards carload lot freight, there will be established shortly an effective method of handling interchange between 13 of the various roads interested, an improvement which has long been sought for in Chicago. There remain about 11 roads, most of which are interested in the middle belt line, but at the present time there seems to be no operating connection between these two belt line systems, although a physical connection exists at Clearing, and additional facilities, if fully used in a spirit of co-operation upon the Clearing plan, would completely relieve the congestion of the inner city, so far as carload lot interchange freight is concerned. As the city expands there will unquestionably come a time when both belt lines will be required to fulfill the function of this Clearing plan so that one of the principal needs for future investigation is the bringing about of the universal interchange clearing yard or yards for all the roads entering the city, at one or more locations as future business may warrant.

Following the same line of analysis previously described for freight entering Chicago, it is found that about 60 per cent. of the total package freight is interchanged between railroads, either by cars, tunnel or teams, the last named being entirely across the streets of the business district. Thus 52 per cent. of the transfer l. c. l. freight is teamed across the business district. The remaining 40 per cent. of l. c. l. freight inbound is entirely for Chicago delivery at the inbound terminal freight house in the downtown district.

In order to carry out this elimination of the interchange it seems evident to me that some clearing plan must be put into effect similar to that previously described for handling e. c. l. business, but just what plan is best or at what location such clearing yard or yards should be I have been unable to ascertain, within the time at my disposal.

The Chicago Tunnel ought to form a most useful vehicle for package freight handled in the business district, and it is a much more logical railroad freight terminal system than the present system of downtown freight houses operating under intensely congested conditions of team delivery. Furthermore, the terminal charge can be borne by the shipper and reasonably be considered to take the place of the cost of team delivery; whereas the absorption of the terminal charge seems to be a matter of privilege expected by the large shipper, which concession the railroad companies fear they cannot give to Chicago without granting store door delivery in all other large cities or be accused by the government of discrimination in favor of Chicago merchants.

The most useful improvement that can be made is the construction of such a type of freight house as will permit for the same team track capacity a much greater area of street or roadway to permit easier access to the stations. This plan has been developed in the studies herein presented for passenger terminal modifications between Canal street and the river and in connec-

tion with a system of elevated viaducts co-ordinated in levels with the present and proposed bridges; also the double-decking of Canal street through this freight area in such a manner that freight houses located on Canal street will be easily accessible from both levels. All freight houses between Canal street and the river are made available on both sides from a viaduct level, thus doubling the average street capacity for a given sized freight house over that which is normally available with the present type of freight house of single deck construction which are mostly used in Chicago.

#### PRESENT OCCUPANCY.

In order to fortify myself as to the possibility of further development of present holdings I have had an examination made to determine how well the holdings are used. From this I can only conclude that either the railroads are holding much of this property for strategic purposes, or else they have failed to take advantage of their opportunities to make use of this land. Furthermore, in the various terminal studies it is shown that if the railroads would agree to pool their interests so that each individual holding could be developed to the best possible extent, more freight facilities could be developed on the existing property between the river and Canal street, with the river as now located or as straightened in accordance with my recommendations, than are displaced by the locating of the new passenger station at Adams street, and a much greater capacity available if the passenger station is located at Harrison street and the space occupied by the proposed Adams street station is then utilized for freight purposes.

Thus looking at the freight problem from the most pessimistic viewpoint of the railroad companies as well as from the city's viewpoint, there is no immediate and pressing necessity for granting the Pennsylvania railroad company any permission to cross city streets in order to utilize any additional property for freight terminal purposes. In case, however, such rights are granted they should be granted subject to the conditions set forth, the principal requirements being the complete depression and covering of all tracks and the erection of such buildings upon the property as will not interfere with normal or efficient use of the surrounding streets, or otherwise make the freight houses objectionable to the communities in which they are located. With such conditions and the operation of all trains by electricity there is no good reason why any property now owned by railway companies in any part of the city of Chicago should not be utilized for terminal purposes, provided the air rights are commercially developed to the greatest extent practicable, and the companies are required to pay the same rate of taxation on such property as contiguous privately owned property pays as the revenue from the terminal railroad property improved in this manner should enable the company to carry far more than the increased tax.

My recommendations on this subject are, however, that the question of individual ownership of the property between Canal street and the river must not be considered predominant if these interests are not in harmony with the most efficient plan of development for all parties concerned, including the city of Chicago; and that no authority for the improvement of any of this property be granted, either for freight or passenger terminals, unless the companies submit plans accordingly.

#### PENNSYLVANIA AND UNION STATION ORDINANCES.

From an analysis of the ordinances asked by the Union Station company it appears that a liberal interpretation would permit far more latitude than was apparently intended in connection with the terminal project. Furthermore, the conclusion cannot be escaped that the city would concede to the railroads much valuable property without receiving commensurate consideration in return therefor. This does not seem equitable in principle or in practice, and a fair consideration of these ordinances should be based upon either an exchange in values or else the equivalent in concessions by both parties to the contract.

Whatever the intent of these ordinances, the concessions

asked of the city appear to be so great as to justify a refusal without equal concessions on the part of the railroads, unless further restrictions be determined upon and more definite terms written into the ordinances, in case it is decided to grant them.

The report in its entirety constitutes a comprehensive study of the various factors that enter into the Chicago terminal problem, with a detailed statistical analysis of the population and traffic development of the city and of the various plans that have been presented for the rearrangement of the present terminal facilities.

Mr. Arnold finds that the railroads collectively own or occupy more property in the heart of Chicago than is occupied for all public or private business, or an area approximating 26,500,000 sq. ft., half of which represents an equity of \$99,375,000. For passenger terminals alone over 1,500,000 sq. ft. of area is occupied, representing at least \$15,000,000 realty value. He estimates that the population of the city will probably double in about 34 years, train mileage in about 23 years, railway passenger traffic in about 13 years, and freight traffic in about 11 years.

Of the large stations in the city he says the North Western and the La Salle are alone fitted for future service to any considerable degree, and that the roads should not be called upon or allow themselves to build expensive terminals in which suburban business will soon crowd out the legitimate long distance business for which such terminals are best adapted.

There are now through and suburban trains moving in and out of Chicago during rush hours, handling 34,000 passengers. During the day approximately 1,400 passenger trains move within the terminal district and the passenger traffic aggregates 193,000 a day. An entirely distinct treatment is called for in the handling of Chicago suburban traffic, which does not demand expensive terminals and elaborate appointments, but the quickest possible access to the business district. The defects in the present arrangements are analyzed and the future treatment of suburban traffic is worked out in several alternative plans.

## STEEL UNDERFRAME BOX CARS.\*

By GEORGE W. RINK,

Mechanical Engineer, Central Railroad of New Jersey, Jersey City, N. J.

It is surprising, in view of the interchange of steel underframe box cars among the railroads, that more has not been accomplished during the past five years toward standardization in design of the various component parts, particularly those which affect the cost of maintenance and require constant repairs due to wear and unavoidable accidents.

During the year 1912, there were built 107,887 box cars of various capacities and dimensions, all varying vastly in detail design of important parts which require frequent renewal, thus making it necessary for all railway storehouses to carry an unnecessarily large stock of repair parts running into very large sums of money. Standards have been adopted by the Master Car Builders' Association which have in large measure reduced the amount of stock necessary to carry. I believe the time has arrived to introduce additional standards affecting the maintenance of box cars which can also be applied to all types of freight cars used in interstate business.

It is reasonable to assume that every railroad manager desires to purchase cars built in a substantial manner. In the absence of standard construction and because of competition, the car builders, when asked to furnish estimates and designs, will sometimes figure on material too light for the service. This, however, is not the fault of the car builder, since, from my own experience, I know that they will gladly add the material where needed, provided they are paid a fair price for the car.

From my observation of steel underframe box cars, I must conclude that engineers did not understand the importance of low fiber stresses in the early designs of steel underframes;

\*Extracts from a paper read before the American Society of Mechanical Engineers at the annual meeting, December 3, 1913.

sufficient attention was not given to the tremendous impact blow which the center sills and car framing have to resist, with the result that large sums of money are now being spent by railroads in making repairs to these cars by reinforcing broken center and draft sills, applying larger capacity draw gears and attachments, and heavier sills. It is not alone the larger locomotives we are using today which has called for a more thorough investigation of the subject of car design and construction, but also the severe shocks which cars are receiving in classification yards. Also the superstructure of box cars should receive just as much attention as the underframe, for how can the roofs be kept in alinement on cars having wood side posts and braces and loose tie rods? The roof is bound to work loose, resulting in leaks which prevent the use of the car for certain commodities.

The application of steel center sills to old cars will no doubt prolong their life. This is now being done by almost every railroad on cars built just prior to the advent of all-steel underframe box cars, but care should be taken to see that sufficient metal is provided to withstand the present service requirements, keeping in view a margin of safety for the future, as no doubt it would be desirable to maintain in service for at least ten years cars to which these steel center sills are applied.

Railway officials in charge of car repairs have seen the results of poor designing and light construction of the earlier steel underframe cars, and during the past three years have materially assisted in the development of the art by insisting upon the production of a stronger car, one that will hold together in all kinds of service with the minimum cost for repairs.

The strains which an underframe has to withstand vary, and depend a great deal on the design and arrangement of the body bolsters, side sills and body framing. With substantial side sills and body bolsters, compressive strains can be transmitted by the latter and thus part of the compressive load can be taken care of by the side sills. However, there is a limit to the load the side sills can take care of which is based on the ratio of length to the least radius of gyration, the length being considered as the maximum distance between adjacent floor beams. In the case of cars with wood body side framing it would appear desirable to provide sufficient area at the smallest section of the center sills to take care of end strains, allowing the side sill to carry only its proportion of the vertical loads due to lading, weight of superstructure and an allowance for vibration.

In the case of box cars with steel side frames there is no question about the ability of the frame structure to carry considerably greater loads, both vertically and due to end shock, on account of the diagonal braces assisting in transmitting the strain throughout the side. For this reason some designers do not consider it necessary to use continuous cover plates on the center sills, but use rolled steel sections for these sills, having a much smaller net area than what is considered good practice by others.

In order to properly analyze the stresses in underframes a standard method of comparison should be made. Cars do not fail as a rule because of the weight of lading, but principally because of strains transmitted through the coupler. The magnitude of the end shocks that underframes have to withstand was investigated in tests conducted prior to 1902, on the Lake Shore & Michigan Southern with a dynamometer car having a capacity of 300,000 lbs. It was found that the tensile and buffing strains, with an engine having a tractive effort of 36,000 lbs., were from 50,000 to 70,000 lbs., and 80,000 to 150,000 lbs. respectively, depending upon the skill of the engineer in manipulating the engine, the train remaining intact. In coupling an engine to its train, buffing strains from 65,000 to 142,000 lbs. were obtained. Thirty cars moving at about  $6\frac{1}{2}$  miles an hour, and coupling to ten loaded cars with brakes set, gave a shock of 376,492 lbs. It would appear from the above results that provisions should be made in designing a steel underframe box car to take care of an impact blow of 350,000 lbs. transmitted throughout all sills. It would therefore seem advisable to as-

sume an end strain of 200,000 lbs. on the center sills of box cars with steel side frames and 300,000 lbs. for box cars with wood side frames for the reasons previously mentioned.

Where structural steel channels are used for center sills, the practice is to extend them to the end sill to serve as draft sills. It has been customary when fish-belly type center sills are used, to provide pressed steel Z-shape draft sills and splice them to the center sill web plates projecting through the bolster. There is a tendency on the part of designers today to do away with the splice by extending the web plates of center sills and providing outside angles to form the draft sill using a continuous cover plate. Where pressed steel center sills and cover plates are used, the practice has been followed of extending this construction to the end sill, bringing the cover plate too near the end of the sill. This construction requires the use of web plates about  $\frac{5}{16}$  in. thick, so as to provide sufficient bearing area for draft lug rivets. I believe that when draft sills have sufficient net area behind the bolster stop, considerations of economical construction would warrant dispensing with the splice, as in view of the additional cost of a splice on 1,000 cars, the expense of its application is not warranted when considering the number of sill failures likely to occur due to its omission.

The impact blow resulting from cars coming together is practically absorbed by the draft gear. Friction gears are more efficient in this respect, absorbing a much greater percentage of total energy than spring gears. Owing to the large variety of gears in service, necessitating numerous designs of draft lugs, key attachments, etc., it would appear that, if a standard arrangement of draft gear and all appliances connected therewith were adopted by all railroads, it would result in great economy of maintenance. This should include striking plates and carry irons, which on a large number of cars are not of sufficient strength, due to the arrangement of the end sills.

It is surprising that more has not been done in the way of standard construction of box cars. The large expenses which railroads are now compelled to face, due to repairs to freight cars, could be partially reduced if standard designs were in use throughout the country. Repairs would be facilitated, due to the use of standard materials throughout for various types of cars, fewer cars would be held up at car repair shops awaiting material from foreign roads, and interchange of cars would not be a hardship to any railroad, as all cars would be of equal strength. Also drawing room expenses would be reduced both for the railroad and car builder, and repair parts could be produced by cheaper methods than those followed at present, due to the elimination of a variety of designs and shapes, principally castings and pressed steel parts.

## SEAMS IN RAILS.

There has been much discussion of the effects of seams in the base of rails during the past two years. Bulletin No. 160 of the American Railway Engineering Association for October, 1913, contains two papers on this subject by H. B. MacFarland, engineer of tests of the Santa Fe, and M. H. Wickhorst, engineer of tests of the rail committee of this association.

The first paper discusses the influence of seams or laminations in the base of rail on the ductility of metal. In a previous paper by Mr. MacFarland, it was shown that the influence of seams or laminations in the base of rails was a most important factor in the failure of rails. This later paper contains a study of six failed rails which had been sent to the laboratory for test. These rails were of 75, 85 and 90 lb. weights; of A. S. C. E., A. R. A. and Santa Fe sections, and rolled by four different manufacturers. This selection was made to secure specimens with dissimilar failures to determine whether or not seams and laminations such as are found in the base of rails failing with characteristic half-moon base failures and with square and angular breaks could be traced through all rails. The specimens were submitted to careful and extensive

tests as a result of which the following general conclusions were drawn:

Rails failing in track may generally be found, upon investigation, to contain numerous black seams in the base.

Base seams are not continuous throughout a rail and vary in depth at different intervals.

Seams materially decrease tensile properties of the metal in the rail base.

Seams decrease strength of rail bases for decreased temperatures.

Transverse strength of rail base is decreased about 10 per cent., due to seams in the base.

The seams in the rail base may be periodical, due to methods of manufacture causing variation in tensile properties at different portions of the rail.

To reduce rail breakage efforts have been made to increase the rail section, when probably the decreased strength of the rail is due more to physical defects contained therein, than to the weight of the sections. More attention should be given to the elimination of base seams and the direct production of a rail with a uniform homogeneous structure.

The second paper covers a study of the development of seams in billets and rails from cracks in the surface of the ingot. From a pile of cold ingots, one was selected with a badly marked surface, and its four sides were "skinned" off in a planer to show clearly the condition of the surface. Photographs were made of these surfaces and of the blooms and rails at various stages of rolling.

This experiment showed that the cracks in the ingot were, in a general way, transverse or obliquely transverse of the ingot. When first bloomed, the cracks on the right and left sides of the ingot as it first entered the blooming rolls, opened up or "yawned" open, forming double V's, one inside the other. Further blooming elongated and closed in the cracks, forming them into elongated Y-shaped flaws, or clusters of them. Still further rolling finally resulted in long narrow Y-shaped seams in the rail, or clusters of them, generally several feet long, as shown up by pickling in sulphuric acid.

The cracks on the top and bottom sides of the ingot as it first entered the rolls, did not open up and finally disappeared so far as could be determined by the appearance of the surfaces of the blooms and rails after pickling in sulphuric acid.

The difference in behavior of the cracks on the top and bottom sides in rolling from the behavior of those on the right and left sides suggests the interesting conclusion that the metal ahead of the rolls is compressed, while that between the rolls is pulled.

The work indicated that seams resulting from cracks in the ingot will be on the web of the rail if what were the right and left sides of the ingot as it first entered the rolls form the sides of the rail, and that they will be on the top of the head and the bottom of the base if these sides of the ingot form the tread and base of the rail.

The cracks on the right and left sides of the ingot as it first entered the blooming rolls, resulted in seams in the rails, while the cracks on the top and bottom sides of the ingot did not result in seams. Seams may therefore possibly be oriented to appear on the sides of the rail or on the tread and the bottom of the base.

**PASSENGER CARS IN SWEDEN.**—There appears to have been considerable development in the Swedish coach in recent years. The new models are much longer and heavier than the old 4-wheeled type, and the swiveled truck is coming into general use. The compartment prevails, but a corridor is run along the inside of the coach, at one side. Sleeping cars are arranged in the same way. Vestibuled coaches are run through from the continent, but can not be said to be in general use in Sweden. Gas is generally used for lighting and steam for heating in the better class of equipment.

## PROPER LOADING OF COAL CARS.

The St. Louis & San Francisco has issued circular No. 39 giving instructions for loading coal on coal cars. With lump and run of mine coal extending above the sides of open cars the lumps must be beveled up to a crown not over 26 in. above the sides on steel coal cars, and not over 20 in. above the sides on wooden cars. The accompanying illustrations show the proper and improper methods of loading cars as shown in the circular. The load on the properly loaded car weighed 107,500 lbs., while the load on the improperly loaded one weighed only 99,000 lbs., making a difference of 8,500



Properly Loaded 50-Ton Gondola Car; Net Weight, 107,500 lbs.

lbs., indicating that 92.09 properly loaded cars would haul as much as 100 improperly loaded cars. On the Frisco system there was an average of 442.95 cars loaded per mine working day during the fiscal year ending June, 1913. If they had been loaded properly there would have been a daily increase in the available car supply of 38.05 cars, which is surely worth consideration.

The proper loading of cars would not only decrease the car shortage, and thereby assist both the shippers and the railroad company, but would also increase the average number of tons per loaded coal car mile and decrease the shipper's



Improperly Loaded 50-Ton Gondola Car; Net Weight, 99,000 lbs.

cost of transportation. The tariff provides that the minimum freight charge on coal shall be the stenciled capacity of the car, and when the shipper does not load with sufficient care to meet this minimum weight he will be paying more than if the car had been loaded properly. When presented in this light the shippers have been eager to conform to the requirements of the circular. It has been found that no extra time per ton loaded has been required to load the cars in the proper manner, and that the losses in transit due to the coal falling off the car have been materially reduced.

**THE RAILWAYS OF QUEENSLAND.**—The Queensland government railways have been designed mainly on the following plan. There are three principal lines running west and southwest from the coast; from Brisbane on the south to Cunnamulla (2,184 miles); from Rockhampton in the center to Longreach (972 miles); and from Townsville in the north to Winton and Cloncurry (792 miles). Five other lines open up the interior from the ports of Bowen, Cooktown, Cairns, Mackay and Normanston. Two other important lines are at present under construction.

## FAIRFAX HARRISON.

Fairfax Harrison, president of the Chicago, Indianapolis & Louisville, was on December 1 elected president of the Southern Railway, the Alabama Great Southern, the Mobile & Ohio and the Virginia & Southwestern, succeeding W. W. Finley, deceased. On the occasion of Mr. Harrison's election the directors of the Southern made public the following statement:

"Mr. Harrison was one of Mr. Finley's closest and most trusted advisers, and is thoroughly in sympathy with the policies which made Mr. Finley's administration so successful both for the Southern Railway Company and the territory served by its lines. Though Mr. Harrison entered the service of the Southern in the legal department, his experience has not been confined to that branch of the service. He has given much study to financial, traffic and operating problems and is intimately acquainted with conditions on the Southern Railway and throughout the section which it traverses. As president of the Chicago, Indianapolis & Louisville he was actively in charge of the operation of the railway, so that he comes to the Southern Railway prepared by practical experience as well as the most detailed knowledge of the details of its affairs to take up the duties of the chief executive."

Mr. Harrison's rise has been almost unique among those of the presidents of large railway systems. Most of the presidents have risen through the operating or traffic department. Mr. Harrison came up through the law and the financial and accounting departments. His advance has been as rapid as the channel through which he has risen has been different from that through which most railway men have risen. He becomes the president of a great railway system when but 43 years old, and after having been connected with the railway business only 17 years.

Railway presidents are not made by accident in this country. When, therefore, a man has come up as Mr. Harrison has there are pretty sure to be good reasons for it. The reasons in Mr. Harrison's case are to be found in the conditions which have developed on the railways of this country within recent years and Mr. Harrison's personal qualities. The railway conditions referred to are those which have made it necessary for a successful railway executive to be not only an expert in the operating sense, but also a railway statesman. He must be able to deal with public sentiment and public officials diplomatically. He must be able to see and accept the good that there is in proposals for the regulation of railways and to oppose skilfully and effectively the things that are bad in such proposals. He must have a broad and deep understanding of economic and social problems in order that he may further good relations between the railway on the one hand, and its employees on the other, and thereby promote the economic welfare of the railway and the safety of its operations. Mr. Harrison's studies, his train-

ing, his experience, and his natural qualities of mind and character have equipped him to grasp and deal with these big problems in a broad and comprehensive way.

His father was Burton Harrison, secretary to Jefferson Davis, President of the Confederate States. His mother is Mrs. Burton Harrison, famous as a writer. His brother, former Congressman Francis Burton Harrison, is now Governor-General of the Philippine Islands. Reared in an atmosphere at once political and literary, Mr. Harrison is one of the most highly educated, widely read, and, in the best sense of the word, scholarly men not only in the railway world, but in any other business in the United States. His writings on railway and other subjects show that if he had chosen a literary career he might have been one of the greatest of American stylists, and that if he had devoted himself to economics he might have been a leading political economist. Having instead entered railway service, he already,

although still a young man, has done work that has put him in the forefront among those who have been striving to promote the best interests of the railways of the United States. As the statement above quoted indicates he was one of the closest and most trusted advisers of W. W. Finley when Mr. Finley was doing his wonderful work of re-establishing good relations between the railways and the public in the South and to put the Southern Railway on a sound operating and financial basis. He served as chairman of the Car Service Commission of the American Railway Association and did constructive work in that capacity, which promises to be in time very fruitful and which already has yielded good results. He was serving as a member of the board that had been arbitrating the controversy between the Burlington and its conductors and trainmen when he was elected president of the Southern. He has made a number of addresses on railway subjects within recent years, every one of which has been notable for its broad, comprehensive views and its beautiful English.



Fairfax Harrison.

Mr. Harrison was born March 13, 1869, in New York City. He was graduated from Yale University, with degree of A.B., in 1890; from Columbia University, with degree of A.M., in 1891, and was admitted to the bar in New York in 1892. He then practiced law in the office of Bangs, Stetson, Tracy & McVeagh, New York, until 1896, when he began railway work as solicitor for the Southern Railway. In 1903, in addition to his duties as solicitor, which title he retained during his connection with the Southern at this time, he was made assistant to President Spencer. He was chosen vice-president in 1906, being in charge of the financial and accounting departments, resigning in August, 1910, to become president of the Chicago, Indianapolis & Louisville. Mr. Harrison is a member of the Permanent Commission of the International Railway Congress, and probably has done more than any railway man in the United States to make the meetings of the congress successful.

## General News.

The Grand Trunk shops at Port Huron, Mich., were destroyed by fire on November 26; loss many hundred thousand dollars.

In the Federal Court at Charleston, W. Va., November 25, the Coal & Coke Railway was fined \$600 for violation of the safety appliance law.

The Denver & Rio Grande has put in service a telephone train despatching system between Salt Lake City and Rio Grande Junction, a distance of 261 miles.

The House Committee on Territories is said to have agreed upon a bill, to be soon presented in Congress, for the construction of railroads by the government in Alaska.

The Pennsylvania Railroad suspended several hundred employees at the Altoona shops on Tuesday of this week and reduced the time in most of the shops from 55 or 60 hours a week to 40 hours a week.

H. E. Montague, traveling passenger agent of the Southern Pacific, was shot and killed, near Los Angeles, on the evening of December 1, while trying to disarm a highwayman who was endeavoring to rob passengers on westbound train No. 9.

On the occasion of the funeral of the late W. W. Finley, president of the Southern Railway, all trains on that company's lines were stopped for five minutes, and all work in the offices and shops was suspended for the same length of time.

W. A. Harriman, son of the late E. H. Harriman, and a director of several railways, has gone to work in the shops of the Union Pacific at Omaha. It is reported he will be given a general experience in various capacities in the shops and offices to learn something of the detail work.

The National Association of Railway Commissioners has appointed five special committees on valuation to represent the state commissions in the five districts into which the country has been divided for the purpose of making the federal valuation of railway property.

A press despatch from Ottawa says that a Board of Conciliation, appointed under the Industrial Disputes Act has settled a controversy between the Grand Trunk Railway and its station and telegraph employees, to the number of 1,300, awarding increases in wages estimated to amount to \$200,000 annually. The decision of the board was unanimous.

In the United States District Court at Boston suit has been begun against the Boston & Maine for a large number of violations of the hours of service law. At Buffalo suit has been begun against the Grand Trunk for violation of the law regulating the number of hours that animals may be kept in cars without food or water. The charges have to do with shipments of cattle from Detroit and other points in Michigan, destined to Buffalo.

W. C. Nixon, receiver and chief operating officer of the Frisco, has announced a plan for the appointment of one additional assistant superintendent on each division of the Frisco. The principal duties of the assistant superintendents will be to supervise stations and correct any conditions which may discommode the public; they will also be vested with authority to rectify any defects or improper practice which they may observe. Ample evidence has been given that Mr. Nixon's plan of vesting the agents with more authority in dealing with the public is appreciated, and this plan is a further effort of the management to accommodate and safeguard the patrons.

On the night of November 25 a special train consisting of a locomotive and two cars was run from Washington, D. C., to Jersey City, N. J., 226 miles, in four hours, the fastest trip ever made between the two cities. The route was over the Baltimore & Ohio, the Philadelphia & Reading and the Central of New Jersey. The train was run for a New York newspaper, to carry photographs taken at the marriage of the President's daughter. Enlargements of the pictures were made before leaving Washington, and some of the development work was done on the train. The train left Washington at 8:10 p. m., and ar-

rived at Jersey City at 12:10 a. m. The best previous run between these cities, of which we find record, was 4 hours 11 minutes, over the Pennsylvania.

Attorney General Lucey of Illinois has refused several requests for an opinion as to whether the anti-discrimination clause of the new public utilities law which goes into effect on January 1 prohibits passes. The act provides "that no public utility or any officer or agent thereof, or any person acting for or employed by it, shall, directly or indirectly, by any device or means whatsoever, suffer or permit any corporation or person to obtain any service, commodity or product at less than the rate or other charge then established and in force as shown by the schedules filed and in effect at the time." It is not generally believed that the legislature intended to make passes illegal, because it defeated an anti-pass bill. Most of the railways are planning to act on the supposition that the clause prohibits passes except to railway employees.

According to press reports the Sumpter Valley has recently settled a strike of its trainmen by awarding an increase in pay to its enginemen. After a brief strike of the trainmen the enginemen and firemen also presented demands on the company. President D. C. Eccles insisted on separate negotiations with the two organizations, and gave the enginemen and firemen an advance in pay and changes in working conditions, securing an agreement on their part not to strike. Then he met the trainmen and declined to reinstate five men who had been discharged during the strike, or to advance wages. The men threatened to strike, but after deciding that such a move would be futile without the enginemen and firemen, were persuaded to accept an agreement which included some changes in working conditions and an anti-strike clause.

"Railophone" is the name of an induction apparatus suitable for a cab signal or an automatic train stop which is being installed for experimental use on the Midland Railway of England at Derby. Signaling points will be arranged in connection with two distant signals. The roadside conductor is contained in a cable, laid underground alongside of the railroad, and the coil of wire carried on the engine is arranged in the form of a frame which is supported by the underframe of the engine, running clear around. A current in the roadside conductor induces a current on the engine and this current holds closed an electro magnet, which, when de-energized, gives a warning signal or opens a valve to apply the power brakes, as may be desired. Separate roadside currents, one to act on westbound trains and the other to act on eastbound, are said to have been worked successfully.

### Conference on Southern Pacific Labor Controversy.

A conference between the officers of the Sunset Lines of the Southern Pacific and the national officers and general committeemen of the four brotherhoods who recently went on strike, was begun at Houston, Tex., on November 24 for consideration of the list of 67 grievances presented by the brotherhoods for adjustment, in accordance with the conditions of the agreement consummated through the federal board of mediation and conciliation. The grievances were taken up one at a time and documentary or oral testimony was presented for each case. It was expected the conference would require ten days to two weeks.

### New York Central Safety Meeting.

A New York Central "Safety First" meeting was held in the auditorium of the Engineering Societies' Building, Thirty-ninth street, New York, on Monday evening last. F. V. Whiting, general claims attorney of the New York Central, acted as chairman. In the absence of Vice-President A. T. Hardin an address was read by F. W. Brazier, superintendent of rolling stock, after which M. A. Dow, general safety agent of the New York Central Lines, delivered an illustrated address. Miles Bronson, general superintendent of the Electric Division, followed with a short talk, and five-minute talks were given by James Covington, conductor; Graham Gray, engineer, and Fred Ferguson, trainman, all New York Central employees. Emphasis was laid by all the speakers on the great necessity of personal care and thought on the part of railway men in order to secure safety. Mr. Bronson laid stress on the subject of dis-



cipline, stating that while it was often considered a hardship by the men, it is absolutely necessary to the safe conduct of a railroad.

#### A Warning.

Since the railroads in Mexico were nationalized freight rates have advanced 25 to 50 per cent. and the physical properties—aside from the damage inflicted by the civil war—have greatly deteriorated. Perhaps there is a warning for this to the shippers of this country, for we are drifting fast toward the nationalizing of our own railroads. All state railroads of Europe and in the antipodes have advanced their freight rates, and it is apparently much easier for a government railroad to advance its rates than for a railroad under private ownership.—*Manufacturers' News.*

#### "Safety First" on the Pennsylvania.

The "Safety First" Committee of the New York division of the Pennsylvania Railroad, J. O. Young, chairman, held a meeting at Jersey City on the evening of November 25, about a thousand employees being present. Short addresses were made, not only by Chairman Young, but also by Superintendent J. B. Fisher and by Engineman H. J. Fackenthal. Besides the usual addresses and stereopticon pictures, two series of motion pictures were given, one entitled "The Usurers' Grip," showing the unfortunate condition of the man who borrows money at exorbitant rates, and the other entitled "A Workman's Lesson," designed to show the distress resulting when a shopman refuses or neglects to use means provided in his shop for safety, and suffers bodily injuries because of his mistaken course.

#### President Favors Alaskan Railroad Project.

The proposals that the government shall build railroads in Alaska, which have been before Congress for some months back, receive a general endorsement from President Wilson. In his annual message, delivered this week, he says: "A duty faces us with regard to Alaska which seems to me very pressing and very imperative. The people of Alaska should be given the full territorial form of government, and Alaska, as a storehouse, should be unlocked. One key to it is a system of railroads. These the government should itself build and administer, and the ports and terminals it should itself control in the interest of all who wish to use them for the service and development of the country and its people."

#### A Federal Employers' Liability Law.

We owe it, in mere justice to the railway employees of the country, to provide for them a fair and effective employers' liability act; and a law that we can stand by in this matter will be no less to the advantage of those who administer the railroads of the country than to the advantage of those whom they employ. The experience of a large number of the states abundantly proves that.—*President Wilson.*

#### Sir William Van Horne's Views.

You all know that the railways of the United States have for a long time been under attack. At every session of the legislature new laws are levelled against them. The public has supported these laws without giving them much thought, and today the railways of the United States are struggling almost for their very existence, many of them standing on the very edge of bankruptcy.

I am quite unable to account for the spirit of hostility against the railways there, for the service of the railways of the United States is—save only Canada—the best in the world; their rates are much lower than any other country in the world save Canada; there is greater regard for public interest and the safety of the individual than in any other country in the world—always save Canada. This precarious situation is the great cloud overshadowing business conditions in North America today.

We have seen in recent years such things as the New York Central being compelled because of the false statement of an employee who swore he couldn't see a certain red light to spend fifty or sixty millions in completely changing their New York terminals. We have seen the New York, New Haven & Hart-

ford hounded by ignorant public opinion, to the very verge of bankruptcy.

Now all these things are catching, and sometimes Canada has shown a tendency to follow suit. I will only cite one instance, and that is the legislation which ten years ago wiped out the small independent local elevator system, with the result that western farmers are getting less for their wheat than ever before.—*Sir William Van Horne: Speech at Toronto.*

#### A Lunch Counter Car on the Pennsylvania.

The greatest annoyance on many heavy express trains is the inability of the dining car to serve all passengers in good season, and the necessity of standing in the narrow passage way while preceding diners finish their leisurely meal. The disposition on the part of some passengers to take their time at the dinner table, notwithstanding the fact that other hungry people stand glaring at them, should perhaps be included as a part of the cause of this difficulty. The Pennsylvania has undertaken a very interesting experiment looking to the abatement of this nuisance. It has built a lunch counter car and is running it experimentally on trains which also have regular dining cars. The new car has just been finished and has been put in service between New York and Philadelphia. While the novelty of the counter car may for a few days prevent a fair comparison in the patronage of the two kinds of cars, it is planned to continue the experiment for a sufficient period to determine just which is the more popular with the traveling public; to see whether a plan by which meals can be served in less time will be satisfactory. The car is 80 ft. long. Instead of tables there is one long mahogany counter extending over half the length of the car; facing this counter on one side are revolving chairs, secured to the floor. The counter is long enough for 21 people to be seated at one time. Back of the counter against the wall there are twenty cupboards for supplies, in addition to receptacles for crushed ice, drinking water, ice cream, milk and cream. Shelves for linen and silver occupy the space under the counter. Sunk in the counter at the end farthest from the kitchen is a cigar humidifier. At one end of the car there is a wash basin for the use of passengers. The pantry and kitchen are at one end of the counter. The pantry contains dish racks, cupboard, a sink and a locker. Food will be passed from the kitchen into the pantry through openings which can be closed by sliding doors. As these openings are just above the serving table in the pantry, there is no necessity for waiters to go into the kitchen. The kitchen itself is about 11 ft. long; it contains a range, broilers, steam table, ice box, coffee urn, soup receptacle and meat warmer. The car is in service on a train leaving Philadelphia for New York at 12 o'clock noon, and on the train leaving New York for Philadelphia at 6 p. m.

#### Rules for Distributing Cars in Texas.

O. C. Castle, car service agent of the Sunset-Central Lines of the Southern Pacific, has issued to agents a circular containing a brief of a statute passed by the Texas legislature as recently amended, prescribing rules for the distribution of freight cars. The circular also gives instructions to agents as to the method of handling orders for cars under this act.

By this it is made the duty of railroads to furnish cars on written application by prospective shippers at such points as are indicated in the application within a reasonable time, such cars to be supplied to persons so applying therefor in the order in which such applications are made, without giving preference to any person.

The time allowed for filling such orders is as follows:

12 cars or less.....	3 days
More than 12 cars and less than 50.....	6 days
50 cars or more.....	10 days

The act also provides that applications should state the number of cars and the place and the time they are desired.

If cars applied for under this act are not furnished, the railroad shall be liable to shipper for \$25 per day for each car failed to be furnished, plus all actual damages sustained by applicant.

Applicant shall deposit with agent, or other representative, at the point the cars are desired, with whom the order is filed, one-fourth of the amount of freight charges for the use of such cars.

Cars shall be fully loaded by shipper within 48 hours after cars are placed; on failure to load within 48 hours, shipper shall pay the railroad company \$25 for such cars not so loaded; provided that when cars placed on orders placed on several days are "bunched" and delivered on the same day, the applicant shall have 48 hours for each car or lot of cars so delivered. In case applicant shall not use the cars ordered he shall pay, in addition to the penalty of \$25 per car, actual damages sustained by the railroad company through his failure to use such cars.

When cars have been supplied and loaded, the railroad company shall deliver to consignees within a reasonable time.

Consignees shall unload within 48 hours after delivery and notice, or forfeit to the railroad company \$25 per day for each car not so unloaded.

Parties bringing suit against the railroad company under this law shall be required to show by evidence that cars, if furnished, would have been loaded within the time specified by this act.

It is also provided that none of the provisions of this act shall forfeit or annul the demurrage regulations provided by the railroad commission, and all penalties accruing to the carrier thereunder shall be cumulative of and in addition to all demurrage charges prescribed by such commission.

#### Threatens Receivership Because Refused Passes.

An interesting alleged correspondence between Chester M. Dawes, general counsel of the Chicago, Burlington & Quincy, and State Senator John T. Denvir, of Chicago, in which the road was threatened with receivership because of the refusal to issue free transportation, was the subject of a hearing at Chicago on November 19, before Examiner Gutheim of the Interstate Commerce Commission.

The correspondence introduced at the hearing began with a letter to Mr. Dawes under date of January 11, 1913, signed with Mr. Denvir's name and written on the stationery of the Illinois legislative public utilities commission, of which Denvir is a member, asking if it would be compatible "to furnish me with annual transportation over your lines for 1913, on account of legislative public utilities commission." To this Mr. Dawes replied: "I regret to say that I will be unable to grant your request for pass over our lines for the ensuing year. This company issues no free transportation, state or interstate, and I can make no exception to the rule."

The third letter, addressed to Mr. Dawes on January 18, and signed with Mr. Denvir's name, included the following: "As chairman of the public utilities commission you can look for legislation that will work hardship on your company, and I wish to assure you that when our commission gets through with you that you will find your road in the hands of a receiver, for you certainly are violating the laws of the state in a great many respects, and we know it, but have gone along and been friendly to you; but inasmuch as you are inclined to be so diplomatic in your statement that you would not 'like to violate the custom you have indulged in,' I feel inclined to think that a little resolution with respect to a committee for a thorough investigation of your gross negligence with regard to your methods of procedure will be well to adopt at the next meeting of the senate. Hoping that you can see fit to favor our commission's request, I am, as ever, faithfully yours."

To this Mr. Dawes replied: "I shall carefully preserve your letter for such future reference as shall be desirable, and am glad to be advised of the methods which control the attitude of an important public servant." The correspondence also included a letter from President Miller to Mr. Dawes, stating that it seemed advisable to make a special file of requests of this kind.

M. Denvir testified at the hearing that he had not written the letters in question, and explained them on the ground of forgery or a joke. He did not explain, however, how Mr. Dawes' reply to his first letter, which was addressed to Mr. Denvir at his home, got into the hands of the alleged jokers to form the basis for the second letter signed with his name.

It is understood that the Interstate Commerce Commission has been collecting evidence, by examining the railway pass records in Illinois during the past year, as the basis for a report on the extent to which passes have been issued to politicians and

others. This is a part of a general investigation now being undertaken by the commission.

#### American Railway Association Meeting at Chicago.

An adjourned meeting of the American Railway Association was held at the Blackstone, Chicago, on Wednesday last, 235 members being represented by 135 delegates. The report of the committee on relations between railroads, action upon which was postponed at the regular meeting last month was again presented. On the recommendation of the committee the following resolution was adopted:

Resolved, That members of the association be requested to report monthly on form C. E. 8 the location of their box cars on foreign lines and of foreign box cars on their lines, these reports to cover all box cars, including ventilated box cars and box cars for furniture and automobiles, excluding only refrigerator cars. (Refrigerator cars are defined as box cars with complete insulation and ice boxes.)

On the recommendation of the committee the association directed that a letter ballot be taken on the question of amending per diem rule 5, with the provision that if a new form is adopted it shall go into effect on January 1, 1914, the date on which the present per diem rule 5 is to be cancelled. The proposed rule is as follows:

"An arbitrary amount for each car in switching service may be reclaimed by each individual switching line from the roads for which the service was performed. This amount shall be based upon the average number of days, *not to exceed 5, actually required in such switching service, to be determined annually by an examination of the records of each individual switching line by the roads directly interested for each local territory.*

"No reclaim shall be allowed for an intermediate switching movement. No reclaim shall be allowed under this rule to a non-subscriber."

On recommendation of the committee per diem rule 6 was amended and two new definitions in connection therewith, covering a subscriber and a non-subscriber road, were adopted and ordered to a letter ballot.

The committee recommended that the standard interchange form be printed on light pink paper when used for deliveries, and on light yellow paper when used for cars received. The committee also reported a new form of junction report to be substituted for the present form D-1; and this was adopted by the association.

The association decided to eliminate per diem rule 18 and the corresponding explanation to demurrage rule 2-D-1 and adopted a new explanation in connection with demurrage rule 5, section A, which is believed will operate more fairly to shippers and carriers than the former arrangement.

The following interpretations of car service rules 10 and 15 were also adopted:

Question—Does rule 10 apply when a car is detained at destination because of refusal by consignee due to delay or damage in transit by accident or other causes?

Answer—No.

Question—Under rule 15, in the absence of a local agreement, should an extra percentage be added to cost for supervision?

Answer—Ten per cent. should be added to the actual cost.

New car service rule 17, in regard to the proper marking of private freight cars, and payments therefor, was adopted.

The committee reported that the General Managers' Association of Texas had held a conference with the committee through its chairman, and that it is probable that supervisors of demurrage will be appointed for that territory.

The following interpretation of section B, rule 1 of the demurrage rules, was adopted:

Question—Does section B, rule 1, apply to cars placed for loading coke or to such cars loaded with coke at bi-product ovens or gas retorts which are not adjuncts to mines?

Answer—No.

On the recommendation of the committee the language of the national demurrage rules was amended to conform to that of the uniform bill of lading, providing that notice be "sent or given."

The association also approved the recommendation that the

explanation to rule 3, section B, of the demurrage rules be made a section of the rule itself.

A standard form of agreement covering notice by telephone under the demurrage rules was adopted.

#### Dinner to Mr. Mellen.

At the dinner which was given at Boston last Sunday in honor of Charles S. Mellen, former president of the New York, New Haven & Hartford and the Boston & Maine, about 250 employees of the Boston & Maine were present, and Mr. Mellen was presented with a set of resolutions, expressing appreciation of his attitude towards the employees while he was president, special reference being made to his decision that the employees might confer with the president on any subject once a month. Mr. Mellen spoke extemporaneously on the power and rights of labor.

Thomas J. Fardy, Jr., presented the resolutions, declaring that "Mr. Mellen has proved himself broader than his time, and linked his name with those of Lincoln and Grant as a man who has been misunderstood."

"It is a fine thing to be the 'old man' of such organizations as yours," said Mr. Mellen in reply to the address. "I would rather have your good will than all the salaries corporations could pay me.

"It is a unique thing, I think, for a railroad president, who has been called a human iceberg and whose doorknob is said to be covered with frost, to receive such a testimonial from the labor organizations among his former employees. Can you think I don't appreciate it? Don't you think it melts the ice a little?

"When I first met the employees on the B. & M. we did not seem to get together much for the first few meetings. I noticed that relations between members of the different organizations were rather strained, so I got them together and told them they must stand together and keep their eyes on the main chance; that it was better for them to compromise than to fight."

Mr. Mellen reminded his hearers of the powers they have as organizations, and warned them against disloyalty and impatience. There is a tremendous latent power in the labor organizations and the reason it does not receive greater reward is the jealousy between the different bodies and lack of loyalty to the common cause.

"Exercise your power with prudence," he said, "and remember that haste makes waste. Be fair, be prudent, be sure, but be steadfast one to the other. . . . I would like to lead, advise and help you. The time will come possibly, and when you call I will not be found wanting," he concluded amid cheers.

#### Chicago Terminal Discussion.

The Chicago city council committee on railway terminals voted on Monday evening in favor of granting an ordinance providing for the location of the new Union passenger station on the site selected by the railways interested, between Jackson boulevard and Adams, Canal and Clinton streets. An ordinance containing several conditions will be drafted by a commission including representatives of the city, of the railways, John F. Wallace, Bion J. Arnold and representatives of the citizens' terminal committee and the Chicago Plan Commission. This action was taken after Mr. Wallace and Mr. Arnold, the engineering experts retained to advise the committee, had agreed that the erection of a new passenger terminal at Jackson street need not interfere with the general plans for future development of the terminal district, which include placing all other south side roads in the proposed new Illinois Central station on the lake front.

The council committee began a series of hearings last week for final consideration of the ordinances presented by the Union Station Company and of the engineering reports submitted by John F. Wallace and Bion J. Arnold. At the hearing on November 25, the officers of the Chicago Plan Commission presented an analysis of the two engineers' reports, together with recommendations of their own in which they opposed the building of a station north of Twelfth street, and insisted that the city delay action on the ordinances until a comprehensive plan for a re-organization of the terminals of the city can be worked out and the railways can be persuaded or compelled to carry out the plan best suited to the city.

At the hearing on November 28 a committee representing the Commercial Club presented a report by L. C. Fritch, chief engineer of the Chicago Great Western, who has made a study of the terminal question for the club. The Commercial Club Committee recommended that if the Pennsylvania Lines are permitted to establish their proposed freight terminal on the west side, the terminals should be located south of Harrison street, so as not to interfere with the future development of that thoroughfare; that all railway tracks north of Twelfth street be depressed below the level of the intersecting streets; and if the passenger station is to be erected on the site proposed between Jackson and Adams streets that the committee consider a site for the proposed postoffice building between the Union and North Western stations. Mr. Arnold and Mr. Wallace held several conferences for the purpose of reaching an agreement on as many as possible of the divergent opinions expressed in their reports. At the meeting on Monday evening at which the committee agreed on the site for the passenger station, they submitted a report outlining the points on which they had reached an agreement. These included the following:

The desirability of two general station sites, in addition to the present Northwestern station; one on the lake front, east of Michigan avenue and south of Twelfth street, and the other on the west side, between Canal street and the river.

Desirability of eventually straightening the river along some line far enough west to permit of the opening of all south side streets as far west as Franklin street.

The opening of Monroe street to permit of the construction of a new bridge across the river.

Desirability of gradually removing the encroachments of railroad property between Michigan avenue and the river.

The tracks north of Twelfth street to be placed underground, and ultimately covered and placed so as to permit the development of space above for warehouse or other commercial uses.

The desirability of the ultimate treatment of the La Salle street station and its facilities for suburban trains as per the Arnold report.

The desirability of handling all, or as much as possible, of non-Chicago freight now handled through the congested portion of the city at some point or points near the outskirts of the city, or outside the city itself.

The desirability of the establishment of a continuing technical board or commission, preferably of three men, to take up, consider and investigate, and to have jurisdiction over matters pertaining to railroad terminal questions, but so constituted that its powers will not conflict with the legislative powers of the city council, or of the powers of the state board of public utilities.

That the Union Station Company and railroad companies should pay or in some other manner compensate the city for all property vacated, or for other concessions granted.

At a meeting of the directors of the Union Station Company on November 25, officers were elected as follows: President, Joseph Wood, first vice-president Pennsylvania Lines West; secretary, W. G. White; treasurer, T. S. Howland, vice-president Chicago, Burlington & Quincy; controller, E. D. Sewall, vice-president Chicago, Milwaukee & St. Paul; general attorney, Robert Redfield. A vice-president is to be elected to have executive charge of the work of construction.

#### Clean Stations.

One of the first things that the average traveler notes on arriving at a railroad station is the condition of the waiting rooms or ticket offices. Cleanliness is one of the missing virtues of many stations because the representative of the railroad company has not swept the cobwebs from his eyes nor learned by comparison how really and permanently attractive clean stations are. A man who is clean within is clean without, and thus the condition of the station may frequently be taken as an index of the mental make-up of the agent himself.

We should endeavor to remember that the general public is really interested in anything which adds to the attractiveness of their individual town and as the railroad station serves as an introduction to the community, it should be as spick and span as the agent's ingenuity and time will permit.—*Sunset Central Bulletin.*

### Safety and Sanitation Conference.

The National Association of Corporation Schools, 124 West Forty-second street, New York, will hold a conference on safety and sanitation at Rumford Hall, 50 East Forty-first street, New York City, December 10, 11 and 12, with sessions at 10 a. m. and 2 p. m. The conference is held under the auspices of the American Museum of Safety, and in connection with the International Exposition of Safety and Sanitation. Questions of safety in shops will be discussed by Dr. William H. Tolman, director of the American Museum of Safety, and safety problems in connection with transportation will be the subject of an address by a representative of the Pennsylvania Railroad. Among the speakers on the program are James O. Fagan, M. A. Dow and Dr. J. B. Hileman, medical examiner of the Pennsylvania Railroad.

### International Railway Congress.

At a meeting of the Permanent Commission of the International Railway Congress Association on July 5 last, V. Tondelier, president of the Executive Committee of the Belgian State Railways, was chosen president of the congress, succeeding Arthur Dubois, deceased. Mr. Tondelier is a graduate of the University of Ghent. He became a railway engineer immediately on graduation and for several years was the manager of the Belgian state railways. The vice-presidents of the congress are C. Colson, of France, and C. Ramaeckers, of Belgium.

The ninth session of the International Railway Congress will open in Berlin, Germany, in the second half of June, 1915.

### American Society of Civil Engineers.

At the regular business meeting of the American Society of Civil Engineers, held December 3, two papers were presented for discussion, as follows: Coal Piers on the Atlantic Seaboard, by J. E. Greiner, M. Am. Soc. C. E., and Topographical Surveys Made by the American Section of the International Boundary Commission, United States and Mexico, by W. W. Follett, M. Am. Soc. C. E. These papers were printed in the *Proceedings* for October, 1913.

### MEETINGS AND CONVENTIONS.

The following list gives names of secretaries, dates of next or regular meetings, and places of meeting.

**AIR BRAKE ASSOCIATION.**—F. M. Nellis, 53 State St., Boston, Mass. Next convention, May, 1914.

**AMERICAN ASSOCIATION OF DEMURRAGE OFFICERS.**—A. G. Thomason, Boston, Mass. Convention, May 19, 1914, St. Louis.

**AMERICAN ASSOCIATION OF GENERAL PASSENGER AND TICKET AGENTS.**—W. C. Hope, New York.

**AMERICAN ASSOCIATION OF FREIGHT AGENTS.**—R. O. Wells, East St. Louis, Ill. Next convention, April 21, Houston, Tex.

**AMERICAN ASSOCIATION OF RAILROAD SUPERINTENDENTS.**—E. H. Harman, St. Louis, Mo.; 3d Thursday and Friday in May.

**AMERICAN ELECTRIC RAILWAY ASSOCIATION.**—E. B. Burrill, 29 W. 39th St., New York. Mid-year conference, New York, January 29, 30, 31.

**AMERICAN ELECTRIC RAILWAY MANUFACTURERS' ASSOC.**—H. G. McConnaughy, 165 Broadway, New York. Meetings with Am. Elec. Ry. Assoc.

**AMERICAN RAILWAY ASSOCIATION.**—W. F. Allen, 75 Church St., New York.

**AMERICAN RAILWAY BRIDGE AND BUILDING ASSOCIATION.**—C. A. Lichty, C. & N. W., Chicago. Next convention, October 20-22, 1914, Los Angeles, Cal.

**AMERICAN RAILWAY ENGINEERING ASSOCIATION.**—E. H. Fritch, 900 S. Michigan Ave., Chicago. Next convention, March 17-20, Chicago.

**AMERICAN RAILWAY MASTER MECHANICS' ASSOCIATION.**—J. W. Taylor, Karpen building, Chicago. June 15-17, Atlantic City, N. J.

**AMERICAN RAILWAY TOOL FOREMEN'S ASSOCIATION.**—A. R. Davis, Central of Georgia, Macon, Ga.

**AMERICAN SOCIETY FOR TESTING MATERIALS.**—Prof. E. Marburg, University of Pennsylvania, Philadelphia, Pa.

**AMERICAN SOCIETY OF CIVIL ENGINEERS.**—C. W. Hunt, 220 West 57th St., New York; 1st and 3d Wed., except June and August, New York.

**AMERICAN SOCIETY OF ENGINEERING CONTRACTORS.**—J. R. Weninger, 11 Broadway, New York; 2d Tuesday of each month, New York.

**AMERICAN SOCIETY OF MECHANICAL ENGINEERS.**—Calvin W. Rice, 29 W. 39th St., New York.

**AMERICAN WOOD PRESERVERS' ASSOCIATION.**—F. J. Angier, B. & O., Baltimore, Md. Next convention, January 20-22, 1914, New Orleans, La.

**ASSOCIATION OF AMERICAN RAILWAY ACCOUNTING OFFICERS.**—C. G. Phillips, Highland Park, Ill. Annual meeting, June 24, Minneapolis, Minn.

**ASSOCIATION OF RAILWAY CLAIM AGENTS.**—C. W. Egan, B. & O., Baltimore, Md. Next convention, May, 1914, St. Paul, Minn.

**ASSOCIATION OF RAILWAY ELECTRICAL ENGINEERS.**—Jos. A. Andreucetti, C. & N. W. Ry., Chicago.

**ASSOCIATION OF RAILWAY TELEGRAPH SUPERINTENDENTS.**—P. W. Drew, 112 West Adams St., Chicago. Next convention, May 20-23, New Orleans, La.

**ASSOCIATION OF TRANSPORTATION AND CAR ACCOUNTING OFFICERS.**—G. P. Conard, 75 Church St., New York. Next meeting, December 9-10, Galveston, Tex.

**ASSOCIATION OF WATER LINE ACCOUNTING OFFICERS.**—W. R. Evans, Chamber of Commerce, Buffalo, N. Y.

**BRIDGE AND BUILDING SUPPLY MEN'S ASSOCIATION.**—L. D. Mitchell, Detroit Graphite Co., Detroit, Mich. Meeting with American Railway Bridge and Building Association.

**CANADIAN RAILWAY CLUB.**—James Powell, Grand Trunk Ry., Montreal, Que.; 2d Tuesday in month, except June, July and August, Montreal.

**CANADIAN SOCIETY OF CIVIL ENGINEERS.**—Clement H. McLeod, 413 Dorchester St., Montreal, Que.; Thursday, Montreal.

**CAR FOREMEN'S ASSOCIATION OF CHICAGO.**—Aaron Kline, 841 North 50th Court, Chicago; 2d Monday in month, Chicago.

**CENTRAL RAILWAY CLUB.**—H. D. Vought, 95 Liberty St., New York; 2d Thurs. in Jan. and 2d Fri. in March, May, Sept., Nov., Buffalo, N. Y.

**CIVIL ENGINEERS' SOCIETY OF ST. PAUL.**—L. S. Pomeroy, Old State Capitol building, St. Paul, Minn.; 2d Monday, except June, July, August and September, St. Paul.

**ENGINEERS' SOCIETY OF PENNSYLVANIA.**—E. R. Dasher, Box 704, Harrisburg, Pa.; 1st Monday after second Saturday, Harrisburg, Pa.

**ENGINEERS' SOCIETY OF WESTERN PENNSYLVANIA.**—E. K. Hiles, Oliver building, Pittsburgh; 1st and 3d Tuesday, Pittsburgh, Pa.

**FREIGHT CLAIM ASSOCIATION.**—Warren P. Taylor, Richmond, Va. Next convention, May 20-22, Galveston, Tex.

**GENERAL SUPERINTENDENTS' ASSOCIATION OF CHICAGO.**—E. S. Koller, 226 W. Adams St., Chicago; Wed. preceding 3d Thurs., Chicago.

**INTERNATIONAL RAILWAY CONGRESS.**—Executive Committee, 11, rue de Louvain, Brussels, Belgium. Convention, 1915, Berlin.

**INTERNATIONAL RAILWAY FUEL ASSOCIATION.**—C. G. Hall, 922 McCormick building, Chicago. Annual convention, May 18-22, Chicago.

**INTERNATIONAL RAILWAY GENERAL FOREMEN'S ASSOCIATION.**—Wm. Hall, 829 West Broadway, Winona, Minn. Next Convention, July, Chicago.

**INTERNATIONAL RAILROAD MASTER BLACKSMITHS' ASSOCIATION.**—A. L. Woodworth, Lima, Ohio. Next convention, third Tuesday in August.

**MAINTENANCE OF WAY & MASTER PAINTERS' ASSOCIATION OF THE UNITED STATES AND CANADA.**—T. I. Goodwin, C. R. I. & P., Eldon, Mo. Next convention, November 17-19, 1914, Detroit, Mich.

**MASTER BOILER MAKERS' ASSOCIATION.**—Harry D. Vought, 95 Liberty St., New York.

**MASTER CAR BUILDERS' ASSOCIATION.**—J. W. Taylor, Karpen building, Chicago. June 10-12, Atlantic City, N. J.

**MASTER CAR & LOCOMOTIVE PAINTERS' ASSOC. OF U. S. AND CANADA.**—A. P. Dane, B. & M., Reading, Mass.

**NATIONAL RAILWAY APPLIANCE ASSOC.**—Bruce V. Crandall, 537 So. Dearborn St., Chicago. Meetings with Am. Ry. Eng. Assoc.

**NEW ENGLAND RAILROAD CLUB.**—W. E. Cade, Jr., 683 Atlantic Ave., Boston, Mass.; 2d Tuesday in month, except June, July, Aug. and Sept., Boston.

**NEW YORK RAILROAD CLUB.**—H. D. Vought, 95 Liberty St., New York; 3rd Friday in month, except June, July and August, New York.

**NORTHERN RAILROAD CLUB.**—C. L. Kennedy, C. M. & St. P.; Duluth, Minn.; 4th Saturday, Duluth.

**PEORIA ASSOCIATION OF RAILROAD OFFICERS.**—M. W. Rotchford, Union Station, Peoria; 2d Thursday.

**RAILROAD CLUB OF KANSAS CITY.**—C. Manlove, 1008 Walnut St., Kansas City, Mo.; 3d Friday in month, Kansas City.

**RAILWAY BUSINESS ASSOCIATION.**—Frank W. Naxon, 2 Rector St., New York. Annual dinner, December 11, 1913, New York.

**RAILWAY CLUB OF PITTSBURGH.**—J. B. Anderson, Penna. R. R., Pittsburgh, Pa.; 4th Friday in month, except June, July and August, Pittsburgh.

**RAILWAY ELECTRICAL SUPPLY MANUFACTURERS' ASSOC.**—J. Scribner, 1021 Monadnock Block, Chicago. Meetings with Assoc. Ry. Elec. Engrs.

**RAILWAY FIRE PROTECTION ASSOCIATION.**—C. B. Edwards, Mobile & Ohio, Mobile, Ala.

**RAILWAY GARDENING ASSOCIATION.**—J. S. Butterfield, Lee's Summit, Mo.

**RAILWAY DEVELOPMENT ASSOCIATION.**—W. Nicholson, Kansas City Southern, Kansas City, Mo.

**RAILWAY SIGNAL ASSOCIATION.**—C. C. Rosenberg, Bethlehem, Pa.

**RAILWAY STOREKEEPERS' ASSOCIATION.**—J. P. Murphy, Box C, Collinwood, Ohio.

**RAILWAY SUPPLY MANUFACTURERS' ASSOC.**—J. D. Conway, 2135 Oliver bldg., Pittsburgh, Pa. Meetings with M. M. and M. C. B. Assocs.

**RAILWAY TEL. & TEL. APPLIANCE ASSOC.**—W. E. Harkness, 284 Pearl St., New York. Meetings with Assoc. of Ry. Teleg. Sups.

**RICHMOND RAILROAD CLUB.**—F. O. Robinson, Richmond, Va.; 2d Monday except June, July and August.

**ROADMASTERS' AND MAINTENANCE OF WAY ASSOCIATION.**—L. C. Ryan, C. & N. W., Sterling, Ill. Next convention, September 8-10, 1914, Chicago.

**ST. LOUIS RAILWAY CLUB.**—B. W. Frauenthal, Union Station, St. Louis, Mo.; 2d Friday in month, except June, July and Aug., St. Louis.

**SIGNAL APPLIANCE ASSOCIATION.**—F. W. Edmonds, 3868 Park Ave., New York. Meeting with annual convention Railway Signal Association.

**SOCIETY OF RAILWAY FINANCIAL OFFICERS.**—C. Nyquist, La Salle St. Station, Chicago.

**SOUTHERN ASSOCIATION OF CAR SERVICE OFFICERS.**—E. W. Sandwich, A. & W. P. Ry., Montgomery, Ala.

**SOUTHERN & SOUTHWESTERN RAILWAY CLUB.**—A. J. Merrill, Grant bldg., Atlanta, Ga.; 3d Thurs., Jan., March, May, July, Sept., Nov., Atlanta.

**TOLEDO TRANSPORTATION CLUB.**—J. G. Macomber, Woolson Spice Co., Toledo, Ohio; 1st Saturday, Toledo.

**TRACK SUPPLY ASSOCIATION.**—W. C. Kidd, Ramapo Iron Works, Hillsburn, N. Y. Meetings with Roadmasters' and Maintenance of Way Association.

**TRAFFIC CLUB OF CHICAGO.**—W. H. Wharton, La Salle Hotel, Chicago.

**TRAFFIC CLUB OF NEW YORK.**—C. A. Swope, 290 Broadway, New York; last Tuesday in month, except June, July and August, New York.

**TRAFFIC CLUB OF PITTSBURGH.**—D. L. Wells, Erie, Pittsburgh, Pa.; meetings monthly, Pittsburgh.

**TRAFFIC CLUB OF ST. LOUIS.**—A. F. Versen, Mercantile Library building, St. Louis, Mo. Annual meeting in November. Noontday meetings October to May.

**TRAIN DESPATCHERS' ASSOCIATION OF AMERICA.**—J. F. Mackie, 7122 Stewart Ave., Chicago. Next convention, June 16, Jacksonville, Fla.

**TRANSPORTATION CLUB OF BUFFALO.**—J. M. Sells, Buffalo; first Saturday after first Wednesday.

**TRANSPORTATION CLUB OF DETROIT.**—W. R. Hurley, L. S. & M. S., Detroit, Mich.; meetings monthly.

**TRAVELING ENGINEERS' ASSOCIATION.**—W. O. Thompson, N. Y. C. & H. R., East Buffalo, N. Y. Next meeting, Chicago.

**UTAH SOCIETY OF ENGINEERS.**—Fred D. Ulmer, Oregon Short Line, Salt Lake City, Utah; 3rd Friday of each month, except July and August.

**WESTERN CANADA RAILWAY CLUB.**—W. H. Rosevear, P. O. Box 1707, Winnipeg, Man.; 2d Monday, except June, July and August, Winnipeg.

**WESTERN RAILWAY CLUB.**—J. W. Taylor, Karpen building, Chicago; 3d Tuesday of each month, except June, July and August.

**WESTERN SOCIETY OF ENGINEERS.**—J. H. Warder, 1735 Monadnock Block, Chicago; 1st Monday in month, except July and August, Chicago.

## Traffic News.

The Traffic Club of New York has chosen as president for the ensuing year, R. H. Wallace, general passenger agent of the Erie.

The directors of the American Express Company have declared a quarterly dividend of 2 per cent., thus reducing the annual rate from 12 per cent. paid since 1906 to 8 per cent.

The Atchison, Topeka & Santa Fe has announced that the Santa Fe-De Luxe train, the 63-hour extra-fare train from Chicago to southern California, will begin its third season on December 9, leaving Chicago on Tuesday of each week.

The special commission appointed by the governor of North Carolina to consider the protests of the railroads against the reductions in freight rates recently made by the legislature of North Carolina, will hold a hearing on Wednesday, December 17, at Raleigh. The chairman of the special commission is M. H. Justice.

The Merchants' Association of New York has adopted resolutions to the effect that the association will neither approve nor disapprove the application of the railroads for authority to make an increase in freight rates.

The freight commissioner of the Philadelphia Chamber of Commerce says that there is no opposition among the merchants of that city to the proposal of the railroads to increase freight rates 5 per cent.: except that rates to the west by rail and lake, which have been increased within the past few years, are deemed high enough, and increases would be opposed.

The Chicago Board of Trade has adopted resolutions regarding the proposed general advance in freight rates in part as follows:

"Resolved, That inasmuch as the commercial interests of the country require increased transportation facilities and more adequate service, which facilities apparently can only be secured by an increase in the revenues of the carriers; therefore, the Board of Trade of the city of Chicago favors a uniform advance of 5 per cent. in all rail rates, thereby furnishing the means to provide additional transportation facilities required.

"Inasmuch, however, as the necessities of the carriers for more revenue have been anticipated in the so-called ex-lake rates, which have been subject to successive increases averaging about 40 per cent., without a corresponding increase in the all-rail rates, we protest against further advances in such rates, as they are at the present time too high."

Reports from Boston say that the conferences which have been held between Commissioner Prouty, of the Interstate Commerce Commission, and representatives of a number of state commissions, have resulted in an agreement which will soon produce orders, both from the federal and the state bodies, allowing the Boston & Maine to make substantial increases in its freight rates.

The Pennsylvania Railroad announces that the exchange of mileage coupons at station ticket offices for passengers boarding sleeping cars is now authorized at Philadelphia, New York, Newark, Jersey City, Trenton, Phillipsburg, Lancaster and Harrisburg. Anyone intending to ride on a train overnight, can take his mileage book to the ticket office and exchange the required number of miles for an ordinary ticket.

The directors of the Merchants' Association of New York City, have sent a memorial to the State Public Service Commission, for the Second district, asking that the Interstate Commerce Commission plan for dividing the country into blocks for the purpose of making rates for the transportation of goods by express, be not adopted in New York, except with certain modifications, as set forth by the Association's Traffic Bureau.

In the Federal Court at Philadelphia, November 25, indictments were returned, by the Grand Jury, charging the Pennsylvania Railroad with illegal discrimination in not collecting demurrage charges on certain shipments to L. F. Miller & Sons. The road is also charged with violation of the law in failing to collect storage and elevator charges; also for paying false claims

for loss of merchandise, the weights of shipment having been mis-stated for this purpose.

The Waycross & Western, a company which is building a railroad from Waycross, Ga., southwest to Ray's Mills, 51 miles, has taken measures to develop stock raising on a large and scientific plan. Alex. K. Sessoms, president of the road, has ordered material for fencing 2,000 acres of land for a stock farm. The farm will be located at a place called Kings, named after the superintendent of the road. Workmen have been busy for several weeks erecting barns and houses at Kings.

Shipments of iron ore from the seven docks at Duluth, Superior, Two Harbors and Ashland, this year, to eastern lake ports have amounted to 40,533,413 tons. The total from these docks in 1912 was 38,904,361 tons. Following are the details:

Docks—	1913.	1912.
Duluth, Missabe & Northern.....	12,331,126	10,495,577
Great Northern .....	13,060,811	13,535,602
Duluth & Iron Range.....	10,075,718	9,370,969
Northwestern (Ashland) .....	3,505,838	3,778,614
Soo (Ashland) .....	832,392	1,018,487
Soo (Superior) .....	696,334	305,112
North Pacific (Superior) (new).....	31,194	.....
Totals .....	40,533,413	38,904,361

On the occasion of an Agricultural Conference held in Philadelphia this week, the Pennsylvania Railroad brought to that city by special trains 2,000 visitors from the corn-growing sections of Ohio; 1,500 junior and 500 senior contestants in a "corn raising contest" conducted by the Ohio Corn Growers' Association this year. The visitors will go also to several other eastern cities. In connection with the conference a corn show will be held in the Philadelphia Bourse, at which will be awarded 96 prizes ranging from \$100 to \$300 each. The corn will be judged by representatives of the State Agricultural Colleges of Pennsylvania, New Jersey, Delaware and Maryland, and the Commercial Exchange of Philadelphia. The prizes have been offered by the Corn Exchange National Bank of Philadelphia.

### Traffic Club of New York.

At the annual meeting of the Traffic Club of New York on November 25, the following officers were elected for the coming year: President, R. H. Wallace, general passenger agent, Erie Railroad; vice-presidents, W. J. L. Banham, traffic manager, Otis Elevator Company, W. W. Hall, general agent, C. M. & St. P., J. T. Rogers, traffic manager, The Edison Companies, W. H. Snell, general agent, passenger department, Canadian Pacific, A. J. Zock, freight agent, Hamburg-American Line; treasurer, Frank C. Earle, 291 Broadway; secretary, C. A. Swope, eastern freight agent, Louisville & Nashville, and for the board of governors, J. L. Carling, W. J. Love, W. H. DeWitt, Jr.

### Car Surpluses and Shortages.

Arthur Hale, chairman of the committee on relations between railroads of the American Railway Association, in presenting statistical bulletin No. 155-A, giving a summary of car surpluses and shortages by groups from August 1, 1912, to November 15, 1913, says: The total surplus on November 15, 1913, was 46,059 cars; on November 1, 1913, 38,276 cars, and on November 7, 1912, 19,897 cars. Compared with the preceding period; there is an increase of 7,783 cars, of which 4,360 is in box, 3,800 in coal and gondola, and a decrease of 158 in flat and 219 miscellaneous car surplus. The increase in box car surplus is in groups 2 (New York, New Jersey, Delaware, Maryland and East Pennsylvania); 3 (Ohio, Indiana, Michigan and West Pennsylvania); 4 (the Virginias and Carolinas); 6 (Iowa, Illinois, Wisconsin and Minnesota); 8 (Kansas, Colorado, Oklahoma, Missouri and Arkansas); 10 (Washington, Oregon, Idaho, California, Nevada and Arizona) and 11 (Canadian lines). The increase in coal and gondola car surplus is in groups 2, 3, 4, 6 (as above), 7 (Montana, Wyoming, Nebraska and the Dakotas); 8 and 10 (as above). The decrease in flat car surplus is in groups 4 (as above), 5 (Kentucky, Tennessee, Mississippi, Alabama, Georgia and Florida); 6, 7, 9 (Texas, Louisiana and Mexico) and 10 (as above). The decrease in miscellaneous car surplus is in groups 2, 5, 6, 7 and 8 (as above).

The total shortage on November 15, 1913, was 23,407 cars; on November 1, 1913, 40,118 cars, and on November 7, 1912, 71,156

cars. Compared with the preceding period; there is a decrease in the total car shortage of 16,711, of which 13,278 is in box and 4,118 in coal and gondola, and an increase of 145 cars in flat and 540 in miscellaneous car shortage. The decrease in box car shortage is in groups 1 (New England lines), 2, 3, 4, 6 and 10 (as above). The decrease in coal and gondola car shortage is in all groups, except 5, 8 and 9 (as above). The increase in flat car shortage is in groups 2, 4, 5 and 6 (as above). The increase in miscellaneous car shortage is in groups 1, 2, 5, 8 and 11 (as above).

Compared with the corresponding period of 1912; there is an increase in the total car surplus of 26,162 cars, of which 14,957 is in box, 1,663 in flat, 3,258 in coal and gondola and 6,284 in miscellaneous car surplus. There is a decrease in the total car shortage of 47,749 cars, of which 36,823 is in box, 3,488 in flat, 6,334 in coal and gondola and 1,104 in miscellaneous car shortage.

The accompanying table gives car surplus and shortage figures

by groups for the last period covered in the report and the diagram shows total bi-weekly surpluses and shortages from 1907 to 1913.

**INTERSTATE COMMERCE COMMISSION.**

The Chicago Coal Dealers' Association has filed a protest with the Interstate Commerce Commission against the proposed 5 per cent. advance in rates on coal included in the general rate advance asked by the eastern railways.

The Omaha Grain Exchange has filed with the Interstate Commerce Commission a complaint against the Northern Pacific and Chicago, Burlington & Quincy, charging excessive and discriminatory rates on grain from points in Montana to Omaha, South Omaha and Council Bluffs.

The commission has suspended from November 25 until March:

**CAR SURPLUSES AND SHORTAGES.**

Date	No. of roads.	Surpluses					Shortages				
		Box.	Flat.	Coal, gondola and hopper.	Other kinds.	Total.	Box.	Flat.	Coal, gondola and hopper.	Other kinds.	Total.
Group 1—November 15, 1913.....	8	0	58	14	291	363	121	73	15	436	645
" 2—" 15, 1913.....	31	564	52	2,857	113	3,586	716	700	293	0	1,709
" 3—" 15, 1913.....	25	1,180	438	328	832	2,782	1,753	50	1,704	1,162	4,669
" 4—" 15, 1913.....	13	3,750	438	1,102	576	5,866	1,138	460	4,454	490	6,542
" 5—" 15, 1913.....	24	40	145	250	468	903	1,705	145	1,414	59	3,323
" 6—" 15, 1913.....	29	4,349	142	1,300	2,254	8,045	591	53	64	344	1,052
" 7—" 15, 1913.....	3	95	24	359	239	717	133	0	20	0	153
" 8—" 15, 1913.....	18	912	365	1,461	1,793	4,531	992	23	398	58	1,471
" 9—" 15, 1913.....	15	1,773	137	509	810	3,229	292	6	42	19	359
" 10—" 15, 1913.....	23	3,671	998	2,340	6,579	13,588	821	94	73	345	1,333
" 11—" 15, 1913.....	6	1,251	417	0	781	2,449	1,378	72	0	701	2,151
<b>Total</b> .....	<b>195</b>	<b>17,589</b>	<b>3,214</b>	<b>10,520</b>	<b>14,736</b>	<b>46,059</b>	<b>9,640</b>	<b>1,676</b>	<b>8,477</b>	<b>3,614</b>	<b>23,407</b>

\*Group 1 is composed of New England lines; Group 2—New York, New Jersey, Delaware, Maryland and Eastern Pennsylvania lines; Group 3—Ohio, Indiana, Michigan and Western Pennsylvania lines; Group 4—West Virginia, Virginia, North and South Carolina lines; Group 5—Kentucky, Tennessee, Mississippi, Alabama, Georgia and Florida lines; Group 6—Iowa, Illinois, Wisconsin and Minnesota lines; Group 7—Montana, Wyoming, Nebraska, North Dakota and South Dakota lines; Group 8—Kansas, Colorado, Missouri, Arkansas and Oklahoma lines; Group 9—Texas, Louisiana and New Mexico lines; Group 10—Washington, Oregon, Idaho, California, Nevada and Arizona lines; Group 11—Canadian lines.

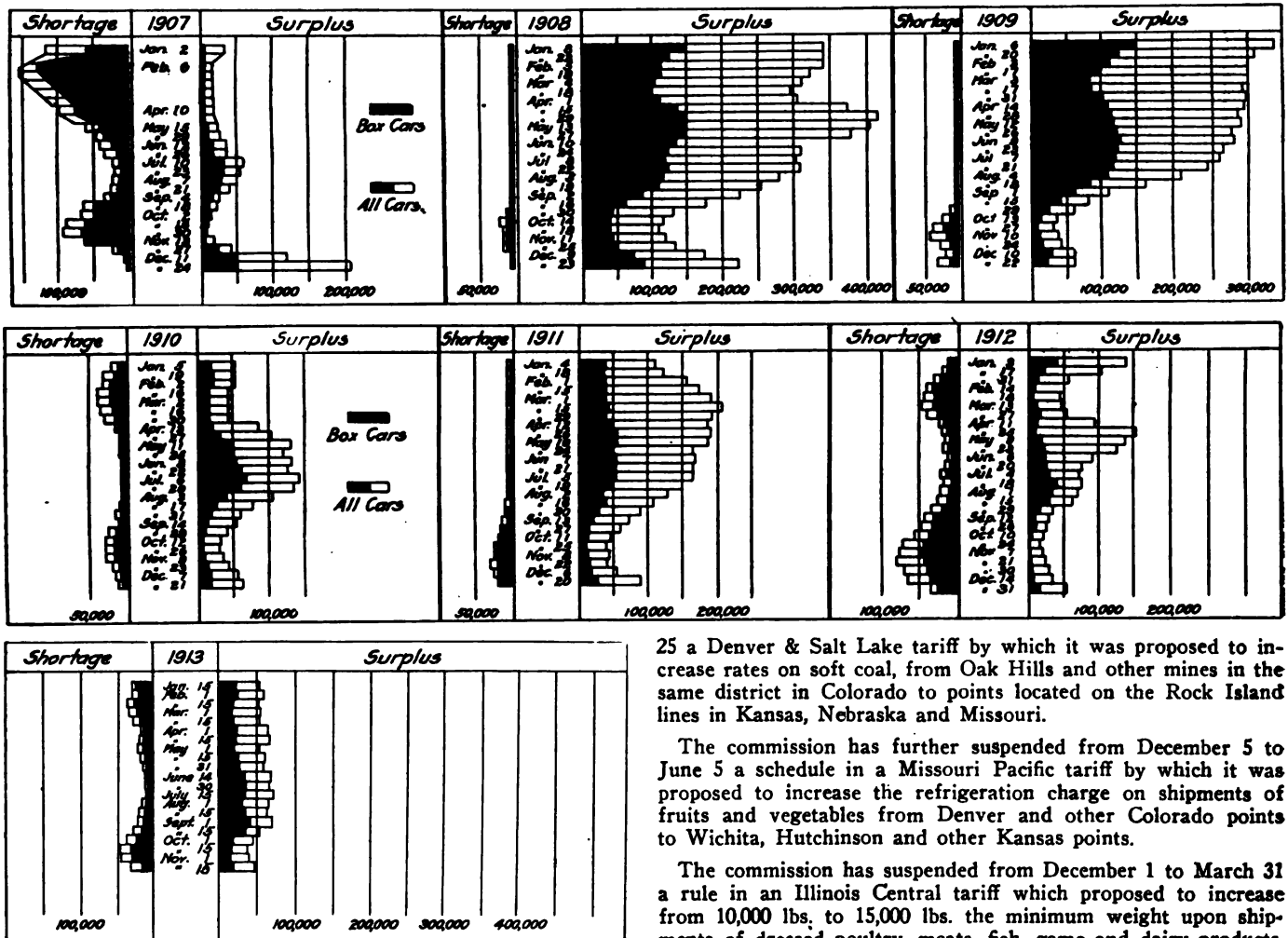

**Car Surpluses and Shortages, 1907 to 1913.**

25 a Denver & Salt Lake tariff by which it was proposed to increase rates on soft coal, from Oak Hills and other mines in the same district in Colorado to points located on the Rock Island lines in Kansas, Nebraska and Missouri.

The commission has further suspended from December 5 to June 5 a schedule in a Missouri Pacific tariff by which it was proposed to increase the refrigeration charge on shipments of fruits and vegetables from Denver and other Colorado points to Wichita, Hutchinson and other Kansas points.

The commission has suspended from December 1 to March 31 a rule in an Illinois Central tariff which proposed to increase from 10,000 lbs. to 15,000 lbs. the minimum weight upon shipments of dressed poultry, meats, fish, game and dairy products, loaded in refrigerator cars moving from Chicago and other sta-

tions on the Illinois Central exclusive of St. Louis, Mo., and East St. Louis, Ill., and destined to points in Florida, Georgia and other southeastern states.

The commission has suspended from November 25 until March 25 the tariff of the Buffalo, Attica & Arcade, which proposed to cancel the present charge of \$3 per car for switching between industries and team tracks on the Buffalo, Attica & Arcade and the Buffalo & Susquehanna at Arcade, N. Y., leaving no rate in effect.

The commission has further suspended from December 13 to June 13 Atchison, Topeka & Santa Fe tariff schedules by which it was proposed to increase the estimated weights applicable to carload shipments of cantaloupes in crates moving from points in New Mexico, Colorado and Kansas to New York and other markets.

The commission has suspended from November 29 to March 29 a St. Louis & San Francisco tariff by which it is proposed to withdraw milling in transit privileges on grain and seed at certain milling points located on the lines of the St. Louis & San Francisco and the Kansas City, Clinton & Springfield, including Joplin, Mo.

The commission has suspended until March 31 tariffs of the Illinois Central, Missouri Pacific, St. Louis, Iron Mountain & Southern, and Mobile & Ohio, by which it was proposed to increase by 1 cent per 100 lbs., the proportional rates on grain, originating from beyond, from St. Louis and East St. Louis to Cairo, Ill. The present rate is 4 cents per 100 lbs.

The commission has suspended from November 29 to March 29 part of a tariff issued by E. H. Hinton, agent, which contains rates from 1 to 7 cents per 100 lbs. higher than the present class rates and rates on iron and steel articles moving from Knoxville, Tenn., to certain stations located on the Cincinnati, New Orleans & Texas Pacific in Kentucky and Tennessee.

The commission has suspended from November 15 until March 15 the supplement to the tariff of the Louisville & Nashville, which contains schedules by which it is proposed to effect increases, ranging in amount from 3 to 7 cents per 100 lbs. in rates on products of cottonseed oil, C. L., from New Orleans, La., and Gulfport, Miss., to the Ohio river and certain other points north thereof.

The commission has suspended from December 2 until April 1 certain schedules in an Erie & Western Transportation Company tariff in which it was proposed to add to the list of articles the transportation of which is prohibited by this carrier—butter, eggs, fresh meats and live or dressed poultry. The commission has already suspended until February 14 tariffs of other carriers which contain a like prohibition.

The commission has further suspended from November 29 until May 29 the items in Agent W. H. Hosmer's tariffs, which contain substantial advances in rates on iron and steel articles, c. l., including old and new rails, steel crossties, and other articles of that nature, between Chicago, Peoria and other points east of the Mississippi river and Des Moines, Ia., Sioux City, Iowa, Sioux Falls, S. D., and other points west of the Mississippi.

The commission has suspended from November 25 until March certain schedules in tariffs of the Illinois Central and the Louisville & Nashville. Tariffs of the above-named carriers now provide for an allowance of  $\frac{1}{4}$  cent per bushel for elevation or transfer of grain, c. l., at St. Louis, Mo., and East St. Louis, Ill., when same is destined to certain points south and east thereof, including Evansville, Ind. It was proposed by the suspended schedules to cancel such allowance on grain destined to Evansville.

The commission has suspended from November 25 until March 25 the supplement to Agent W. P. Emerson's tariff, which contains a proposed increase of  $1\frac{1}{2}$  cents per 100 lbs. in rates applicable to the transportation of coffee, C. L., from New Orleans and Port Chalmette, La., to Cincinnati, Louisville, Cairo, St. Louis, Chicago and Milwaukee, and a proposed increase of 2.4 cents per 100 lbs. on the same traffic to Dubuque, Iowa. The present rate to Chicago is 25 cents and the proposed rate is 26.5 cents.

The commission has suspended from November 20 and December 5, respectively, until March 20, the schedules in a supple-

ment to the tariff of the Northern Pacific and the supplement to the tariff of the Chicago, Milwaukee & St. Paul, which proposed to withdraw the present commodity rates applicable to the transportation of cement, c. l., from Mason City, Ia., and other points to certain points in Minnesota and North Dakota located on the Northern Pacific, class rates to apply on after the effective dates thereof. This would result in material increases; for example, the present rate from Mason City, Ia., to Fargo, N. D., is 17 cents per 100 lbs., and the proposed class rate is 28 cents per 100 lbs.

#### Complaint Dismissed.

*East Dubuque Supply Company v. Illinois Central. Opinion by the commission:*

The commission finds that a rate of 5 cents per 100 lbs. on beer in carloads from Dubuque, Iowa, to East Dubuque, Ill., is not unreasonable. (28 I. C. C., 425.)

*Meridian Board of Trade & Cotton Exchange v. Alabama, Great Southern, et al. Opinion by Commissioner Prouty:*

The commission found that the present adjustment of rates from Mobile and Tusculoosa, Ala., to stations on the Tombigbee Valley and Alabama, Tennessee & Northern railroads, was not discriminatory as against the rates from Meridian, Miss. (28 I. C. C., 360.)

*Birge-Forbes Company v. Missouri, Kansas & Texas, et al. Opinion by the Commission:*

The complainant contends that the rates charged by the defendant for transportation of certain shipments of cotton from points in Oklahoma to New Orleans, La., are unreasonable and unjustly discriminatory. Reparation is asked. The commission found that the evidence was not conclusive. (28 I. C. C., 409.)

*Clinton Sugar Refining Company v. Chicago & North Western Railway Company. Opinion by Commissioner Prouty:*

Under the tariffs of the defendant in force between May 3, 1910, and August 15, 1912, taken in connection with the requirements announced by the commission touching the shipment of the products of grain milled in transit, the complainant is not entitled to a recovery on account of unused transit. (28 I. C. C., 364.)

*American Brake Shoe & Foundry Company v. Belt Railway Company of Chattanooga, et al. Opinion by Commissioner Prouty:*

The commission decided that the rule of the carriers, providing that where cars are switched to private scales for weighing, a charge of fifty cents per car would be made unless weights so ascertained were used for the assessment of freight charges, was not unreasonable. (28 I. C. C., 350.)

*National Coal Company v. Baltimore & Ohio. Opinion by Commissioner Marble:*

A carrier rated a coal mine and distributed cars to it strictly in accordance with established rules, fairly adopted after consultation with and approval by mine operators. The commission found that such carrier cannot be held guilty of undue discrimination against such mine on a showing that the shipper's commercial misfortunes in the months used, under the rules, to determine the rating of the mine, operated to reduce such rating. (28 I. C. C., 442.)

*Charles F. Schmidt & Peters, Inc., v. Atchison, Topeka & Santa Fe, et al. Opinion by the Commission:*

The complainant contends that the rate of \$2.25 per 100 lbs., any quantity, for the transportation of champagne from New York to California terminals, is unreasonable and discriminatory to the extent that it exceeds \$1.55 per 100 lbs. in carloads, minimum weight 30,000 lbs., and a less-than-carload rate of \$2.00 per 100 lbs. Reparation is asked. The commission decided that the present rates were not shown to have been unreasonable. (28 I. C. C., 376.)

*Minneapolis Cereal Company v. Chicago & North Western, et al. Opinion by the Commission:*

The complainant alleges that unreasonable charges were collected by the defendant for the transportation of carload and less-than-carload shipments of the cereal food "Cream of Rye," containing premiums, from Belle Plaine to points in western and official classification territories. Reparation and the establish-

ment of reasonable rates are asked. The commission decided that the charges paid by the complainant under the rules in question are not unreasonable or discriminatory. (28 I. C. C., 415.)

*H. L. Keats Auto Company v. Oregon-Washington Railroad & Navigation Company, et al.*

*Menzies-DuBois Auto Company v. Oregon-Washington Railroad & Navigation Company, et al. Opinion by the Commission:*

The complainants contend that the less-than-carload rates of \$7.00 per 100 lbs. on shipments of automobiles from New York and Syracuse, N. Y., to Portland, Ore., are unreasonable to the extent that they exceed \$4.50 per 100 lbs. The commission found that the evidence was not conclusive. (28 I. C. C., 412.)

#### Rate of Twenty-Three Cents on Coffee Reasonable.

*Traffic Association of St. Louis Coffee Importers v. Illinois Central, et al. Opinion by the commission:*

The complainants allege that the rate of 23 cents per 100 lbs. for the transportation of coffee in carloads from New Orleans, La., to St. Louis, Mo., is unreasonable and discriminatory to St. Louis as compared with the rates on coffee from New Orleans, to Indianapolis, Ind., or the rates on sugar from New Orleans to St. Louis. The commission finds, however, that the present rates are reasonable, and therefore dismisses the complaint. (28 I. C. C., 484.)

#### The Free Return of Exhibits.

*The Dairymen's Supply Company v. Pennsylvania Railroad et al. Opinion by the commission:*

The complainant claims that it is discriminated against because the defendants refuse to return free certain exhibits at a dairy show while making it a practice to return free exhibits at state and county fairs. The complaint is dismissed on the ground that a dairy show is an industrial exposition run for the purpose of advertising, while state fairs, etc., are for educational purposes. (28 I. C. C., 406.)

#### Detroit Switching Charges.

*Opinion by Commissioner Prouty:*

The commission finds that the Michigan Central and Pere Marquette have failed to show proper justification for increases in charges for switching at Detroit, Mich., and finds that their present charges are just and reasonable. The Detroit Terminal Railroad also has not justified its proposed increases, but it is allowed to recast and somewhat increase its present switching charges. Hereafter it may charge not to exceed \$4.50 per car for a switching movement between any two points on its line. (28 I. C. C., 494.)

#### Complaint Dismissed.

*Milwaukee Maltsters' Traffic Association v. Grand Trunk Western et al. Opinion by the commission:*

The commission finds that the defendants' refusal to allow one-fourth cent for the elevation and transfer at Milwaukee, Wis., of barley converted into malt at that place while paying this allowance for the elevation and transfer of barley and other grain which has been clipped, cleaned, blown or mixed, does not result in unjust discrimination. The maltsters do not perform a transportation service, for in the case of barley converted into malt there is no real elevation. Whereas grain is delivered into the elevator, not grain but a manufactured and more valuable product of grain is unloaded out of it. Moreover, as it is, the maltsters are malting barley in transit and are thus paying for but a single service of transportation as though there were no stop for manufacturing purposes at Milwaukee. (28 I. C. C., 489.)

#### STATE COMMISSIONS.

In a report on an accident to a passenger train at Chelsea, Okla., on October 20, the Oklahoma Corporation Commission recommends that the St. Louis & San Francisco spend \$3,000 a mile in improving its lines in the state. The commission is now making a general physical investigation of the road.

It is expected that the National Association of Railway Commissioners' committee conference on express matters, to be held at Chicago December 11, will be attended by one member from

each state commission. The question of a uniform method of stating intrastate express rates should be determined promptly. The express companies have been asked to be represented and have signified their intention of doing so.

E. C. Hurd, chief engineer of the Nebraska State Railway Commission, in charge of valuation, has resigned and will engage in private practice in Lincoln and Chicago. C. H. Gerber, principal assistant engineer, will assume Mr. Hurd's duties. Mr. Hurd has had charge of this work since June, 1909. It included valuation not only of the property of railroads, but also that of express companies, and telegraph and telephone lines. The work is now practically completed. He has been engaged in general engineering work for about 20 years.

#### COURT NEWS.

The Supreme Court of the United States has sustained the district court of the western district of New York in a decision imposing a fine of \$2,000 on the Delaware, Lackawanna & Western for violation of the commodities clause of the Interstate commerce law. The railroad transported hay from Black Rock, N. Y., to Scranton, Pa., to be sold to or used in its own coal mine stables.

A hearing was begun before the United States District Court at Baton Rouge, La., on November 27 on a suit filed by the Illinois Central and the Yazoo & Mississippi Valley railways to test the authority of the Louisiana railroad commission to prescribe flagging rules. The witnesses included F. C. Rice, chairman of the transportation committee of the American Railway Association, and W. L. Park, vice-president of the Illinois Central.

The Supreme Court of the United States has handed down a decision which sustains as valid the order of the Interstate Commerce Commission prescribing a system of accounts for the Kansas City Southern. The decision upholds that clause of the interstate commerce law which authorizes the commission to prescribe a system of accounts. The railroad company entered suit, challenging the authority of the commission to require depreciation to be charged according to an arbitrary rule.

The United States Circuit Court of Appeals, at St. Louis, November 28, decided in favor of the Chicago, Burlington & Quincy in the suit of that road, in the district court at Kansas City, claiming that the federal law, requiring the use of air brakes on freight trains, does not apply to switching operations. The court's opinion said the evident intention of Congress in passing the act was to exempt purely switching operations because it would take more than twice as much time to switch cars if they must have the air coupled each time. Judge Hook, dissenting, declared that since the same dangers existed on switching trains as on regular trains there should be no exemption in this case. He further referred to the fact that the law does not exempt switching operations.

In the United States District Court at Macon, Ga., November 24, the Seaboard Air Line Railway Company, indicted on thirteen counts for violation of the act to regulate commerce, entered pleas of guilty to two of the counts and was fined \$1,000 on each by Judge W. B. Shepherd, after which District Attorney Akerman nol prossed the remaining eleven counts. The indictment was based on the allegation that the Seaboard had accepted concessions from the Southern Railway on shipments of bituminous coal from Briceville and Oliver Springs, Tenn., to Williams, Ga. Between those points a joint rate of \$2.45 a ton prevailed, the Southern Railway bringing the coal from Tennessee to Helena, Ga., where it was turned over to the Seaboard, to be transported to Williams. It was alleged that the Seaboard paid the Southern Railway its pro rata share of the rate, or \$1.36 a ton, but did not take the coal on to Williams.

The Supreme Court of the United States has decided that there was no discrimination against refineries at Yonkers in the allowance by the trunk line railroads of lighterage to the Arbuckle Sugar Refineries in New York Harbor. The litigation was begun by the Federal Refinery, at Yonkers, to get the same allowance for lighterage its sugar as was allowed to the Arbuckle Refineries, which are within the New



REVENUES AND EXPENSES OF RAILWAYS.

MONTH OF SEPTEMBER, 1913.

THREE MONTHS OF FISCAL YEAR, 1914—CONTINUED.

Table with columns: Name of road, Average mileage operated during period, Operating revenues (Freight, Passenger, inc. misc.), Operating expenses (Way and structures, Maintenance of equipment, Traffic, Trans-shipment), General, Total, Net operating revenue (or deficit), Outside operations, net, Taxes, Operating income (or loss), Increase (or decrease) last year. Rows include Alabama Great Southern, Arizona Eastern, Atlantic & St. Lawrence, etc.

REVENUES AND EXPENSES OF RAILWAYS.

MONTH OF OCTOBER, 1913.

Table with columns: Name of road, Average mileage operated during period, Operating revenues (Freight, Passenger, Total), Maintenance of way and equipment, Traffic, Transportation, General, Total, Net operating revenue, Outside operations, Taxes, Operating income, Increase (or decrease) last year.

York lighterage district. In order to entitle its shipments to the rebate, it was asserted, the Federal Refinery brought its lighters within the New York area, tied up at a dock, and then continued the journey to the freight station. The defendant railroads claimed that the lighterage allowance demanded by the Federal Company and granted by the Interstate Commerce Commission was in itself excessive. The decision sets aside the order of the commission which brought Yonkers within the lighterage district of New York.

The Supreme Court of the United States has upheld a decree of the Circuit Court for the eastern district of Kentucky which had denied a petition of the Louisville & Nashville to have an order made by the Kentucky Railroad Commission set aside. The railroad had attacked the validity of the law under which the commission had acted. The order to which the railroad objected had restored certain rules formerly in effect as to special shipments by distillers. Prior to the order the L. & N. had departed from these rates and put into effect an increase. In restoring the original rates the state commission provided that they should be enjoyed not only by the distillers and other special shippers who had enjoyed the benefit of them, but that they should be made available to the public generally. Justice Hughes delivered the opinion. The fixing of rates is declared to be a legislative and not a judicial function and as to the validity of the state law, he reiterated the policy of the Supreme Court not to pass on the validity of a state law until after it had been tested in the highest court of the state.

#### Tap Line Order Overruled.

The United States Commerce Court on November 26 decided against the Interstate Commerce Commission in the so called tap-line cases, holding that the distinctions made by the commission between transportation of property belonging to the tap line's own mills and that belonging to other mills, and the commission's prescribing distances to which the tap line special privileges should be limited are arbitrary, and beyond the power of the commission. The cases are those of the Louisiana & Pacific, the Woodworth & Louisiana Central, the Mansfield Railway & Transportation and the Victoria, Fisher & Western. A similar opinion was handed down in the case of the Butler County Railroad. All of the decisions were by Judge Mack.

It is held that the commission was without power to forbid an allowance to be made by trunk lines to the petitioning proprietary industries for switching, and it was also without power to prohibit the making of joint rates by the trunk lines and the petitioning tap lines and the payment by the former to the latter of some division thereof for its services. The commission, however, has power to regulate the amount of allowances where unjust discrimination or illegal favoritism may be found.

The complaint filed with the commission to secure an order compelling the re-establishment of through routes and joint rates, which was dismissed by the commission, is not considered by the court, it being held that a negative order like this does not come within the jurisdiction of the court.

#### Mileage Tickets in Georgia.

The Supreme Court of Georgia has sustained the railroad commission of that state in its order, requiring railroads to accept mileage coupons on trains, thereby denying the claim of the railroads to the right to enforce a rule requiring the coupons to be delivered at the station ticket office at the beginning of each journey, and exchanged for a trip ticket. The case will probably be carried up to the Supreme Court of the United States. Justice Beck dissented. The original order passed by the railroad commission was signed by only three of the five commissioners, two voting against it.

It will be recalled that the Interstate Commerce Commission recently decided that, as regards interstate journeys, the rule requiring coupons to be exchanged at the station office, was not unreasonable.

It is said that the railroads of Georgia will now refuse to sell interchangeable mileage books, and traveling men will be obliged to buy separate books on each road. The railroads took action like this in South Carolina when a similar order was put in force in that state.

## Railway Officers.

### Executive, Financial and Legal Officers.

Oscar Lawler has been elected auditor of the San Pedro, Los Angeles & Salt Lake, with headquarters at Los Angeles, Cal., succeeding H. I. Bettis, deceased.

The election of Fairfax Harrison, president of the Chicago, Indianapolis & Louisville, as president of the Southern Railway, succeeding W. W. Finley, deceased, is commented on elsewhere in this issue.

John C. Bills has been appointed assistant general solicitor of the Pere Marquette, with office at Detroit, Mich., and Parker, Shields & Brown succeed the firm of Bills, Parker, Shields & Brown as general attorneys, with offices at Detroit.

F. C. Uhlman, assistant general auditor of the Western Maryland, has been appointed general auditor, succeeding Robert Casson, who will take up important work in connection with the valuation of all properties of the Western Maryland made necessary by the bill recently passed by congress.

### Operating Officers.

J. S. Denham, car accountant of the Georgia & Florida at Augusta, Ga., having resigned, T. D. Simmons has been appointed acting car accountant, with office at Augusta.

Webb C. Ball has been appointed general time inspector of the New York, New Haven & Hartford and the Central New England, with headquarters at New Haven, Conn.

T. S. Mahoney, trainmaster of the Texas & Pacific at New Orleans, La., has been appointed superintendent of terminals at New Orleans, La., succeeding P. L. Wing, transferred.

William H. Corbett has been appointed trainmaster of the Minnesota division of the Minneapolis, St. Paul & Sault Ste. Marie, succeeding A. W. Shepherd, assigned to other duties.

Charles W. Brown, engineer maintenance of way of the Lehigh & New England at South Bethlehem, Pa., has been appointed assistant superintendent, with office at South Bethlehem.

B. C. Byers, superintendent of the Peoria & Eastern division of the Cleveland, Cincinnati, Chicago & St. Louis, at Indianapolis, Ind., has been transferred to the superintendency of the Cairo division, with headquarters at Mt. Carmel, Ill., succeeding P. J. Maloney, resigned.

Joseph H. Gumbes, assistant superintendent of the Pittsburgh division of the Pennsylvania Railroad at Youngwood, Pa., has been appointed superintendent of the Renova division, with headquarters at Renova, succeeding W. G. Coughlin, promoted, and John M. James, superintendent of motive power of the Western Pennsylvania division at Pittsburgh succeeds Mr. Gumbes.

James S. Moore, whose appointment as assistant superintendent of the Virginian Railway, with headquarters at Victoria, Va., has been announced in these columns, was born on October 15, 1868, in Edgecombe county, N. C. He was educated in the common schools of North Carolina, and in the summer of 1886 began railway work as a telegraph operator on the Atlantic Coast Line. Four years later he entered the service of the Richmond & Danville as an operator, and a few months later was promoted to train despatcher. In 1892, he was appointed despatcher on the Georgia, Southern & Florida, at Macon Ga., and in 1900, went to the Seaboard Air Line as train despatcher, at Richmond, Va., remaining in that position until the summer of 1906. The following year he was appointed train despatcher on the Virginian Railway, and in 1908, was promoted to chief despatcher, which position he held at the time of his recent appointment as assistant superintendent of the same road, as above noted.

### Traffic Officers.

D. U. Wilder has been appointed traveling passenger agent of the Louisville & Nashville with headquarters at Jacksonville, Fla.

H. T. Mason has been appointed mail traffic manager of the St. Louis & San Francisco, with office at St. Louis, Mo., succeeding Guy Adams, resigned.

R. G. Hanson, Jr., agent in the land and industrial department of the Southern Railway at Bristol, Tenn., has been appointed industrial agent of the Missouri, Kansas & Texas, with headquarters at St. Louis, Mo.

R. C. Weller has been appointed industrial agent of the Lake Shore & Michigan Southern, Pittsburgh & Lake Erie and Lake Erie & Western, with headquarters at Cleveland, O., in place of H. J. Perkins, who has been appointed industrial agent of the Michigan Central at Detroit. Mr. Perkins succeeds W. S. Crowl, appointed general agent at Detroit.

Charles D. Fisher, city passenger and ticket agent of the Chicago Great Western, at Minneapolis, Minn., has been appointed assistant general passenger agent, with headquarters at Minneapolis. F. R. Thomas succeeds Mr. Fisher. J. E. Boggs has been appointed city passenger and ticket agent at St. Paul, Minn., succeeding M. F. Montgomery, resigned, to engage in other business.

#### Engineering and Rolling Stock Officers.

Charles Bowersox, general foreman of the Toledo & Ohio Central at Bucyrus, O., has been appointed master mechanic at that point.

William J. Calvin has been appointed roadmaster of the Northern Pacific at Sedro-Wooley, Wash., in place of William H. Gale, resigned.

W. C. Hattan has been appointed division engineer of the Elkhorn extension of the Carolina, Clinchfield & Ohio, with headquarters at Dante, Va.

J. V. B. Duer, foreman of motormen of the Manhattan division of the Pennsylvania Railroad at New York, has been appointed assistant engineer, with headquarters at Altoona, Pa., succeeding B. F. Wood, resigned.

Robert F. Byers, formerly shop foreman of the National Railways of Mexico, at Aguascalientes, Mex., has been appointed master mechanic of the Central Dominicano Railway, with headquarters at Porto Plata, Dominican Republic.

C. F. Stoltz has been appointed signal engineer of the Cleveland, Cincinnati, Chicago & St. Louis and the Peoria & Eastern, with headquarters at Cincinnati, Ohio, succeeding L. S. Rose, assigned to other duties in connection with valuation work.

F. W. Gilcreast, chief engineer of the Lehigh & New England, at Mauch Chunk, Pa., has been appointed engineer maintenance of way, with office at South Bethlehem, Pa., succeeding Charles W. Brown, promoted, and his former position has been abolished.

W. G. Coughlin, superintendent of the Renovo division of the Pennsylvania Railroad at Renovo, Pa., has been appointed engineer of maintenance of way with headquarters at Philadelphia, succeeding L. R. Zollinger, deceased. J. M. Henry, master mechanic of the West Philadelphia shops, has been appointed superintendent of motive power at Pittsburgh, succeeding J. M. James, promoted.

G. C. Cleaver, division engineer of the Buffalo, Rochester & Pittsburgh, at Du Bois, Pa., has been promoted to engineer maintenance of way, with headquarters at Rochester, N. Y. E. W. Hammond, division engineer at Rochester, has been promoted to division engineer in charge of Divisions 3, 4 and 5, with headquarters at Du Bois, and J. P. Reynolds has been promoted to division engineer of Divisions 1, 2 and Erie division, with headquarters at Rochester.

#### OBITUARY.

James Hagerman, formerly general counsel of the Missouri, Kansas & Texas, died in St. Louis, Mo., November 14, aged 65 years. Mr. Hagerman had been connected with the Missouri, Kansas & Texas since 1888, when he was made general counsel for the receivers of that company. When the company was reorganized in 1891 he was appointed general solicitor of the reorganized system, and in 1904 he was made general counsel, which position he resigned in June, 1912, owing to ill health, when he was made consulting counsel.

## Equipment and Supplies.

### LOCOMOTIVE BUILDING.

THE KANAWHA & MICHIGAN has ordered seven consolidation locomotives from the American Locomotive Company.

THE BROOKLYN RAPID TRANSIT COMPANY, Brooklyn, N. Y., has ordered two 55-ton electric locomotives for switching and light freight service from the General Electric Company.

THE WESTERN MARYLAND has ordered 20 consolidation locomotives from the American Locomotive Company and 5 or 6 switching locomotives from the Baldwin Locomotive Works.

### CAR BUILDING.

THE MINNEAPOLIS & ST. LOUIS has ordered 500 box cars from Haskell & Barker.

THE CHICAGO GREAT WESTERN has ordered 6 coaches from the American Car & Foundry Company.

THE STANDARD OIL COMPANY is said to be inquiring for 6 or 7 special coke cars. This item has not been confirmed.

THE ARMOUR CAR LINES are said to be building from 400 to 500 refrigerator cars. This item has not been confirmed.

THE MINNEAPOLIS, ST. PAUL & SAULT STE. MARIE has ordered 6 coaches, 2 parlor cars and 2 buffet observation cars from the Barney & Smith Car Company.

THE LEHIGH VALLEY has ordered 1,000 50-ton, all steel coal cars from the Standard Steel Car Company, and 40 steel underframe caboose cars from the company shops. The company is also having 500 coal cars rebuilt by the Middletown Car Company at Middletown, Pa., and 500 box cars by the American Car & Foundry Company at Bloomsburg, Pa.

THE LOUISVILLE & NASHVILLE has bought 800 steel underframes from the Mt. Vernon Car & Manufacturing Company, and 300 steel underframes from the American Car & Foundry Company.

THE EAST BROAD TOP RAILROAD & COAL COMPANY has ordered 30 narrow-gage, steep hopper cars from the Pressed Steel Car Company. These cars will be similar to those described in the *Railway Age Gazette* of June 27, 1913, page 1606; except that they will have an additional length of 2½ ft. and 3,600 lbs. increased capacity. They will be equipped with Vulcan trucks and cast steel truck bolsters.

### IRON AND STEEL.

THE ILLINOIS CENTRAL has ordered 264 tons of steel for a bascule bridge at Galena, Ill., from the American Bridge Company.

THE CHICAGO & EASTERN ILLINOIS has ordered 300 tons of steel from the Morava Construction Company for its shops at Danville, Ill.

### SIGNALING.

The Philadelphia & Reading has awarded to the Federal Signal Company a contract for an electric interlocking plant at Newtown Junction, near Philadelphia. The machine will have 40 levers.

The Duluth, Winnipeg & Pacific has contracted with the Federal Signal Company for a 36-lever mechanical interlocking plant at the connection of its line with the Northern Pacific, at West Duluth, Minn. The home signals will be type "4" top post, and distant signals will be type "4A" bottom post, motor signals. The Federal Signal Company has been awarded the contract for material for a 36-lever mechanical interlocking plant to be installed by the Louisville & Nashville, at the crossing of the Alton and Southern, near East St. Louis, Ill. The home and distant signals will be motor-operated type "4A" bottom post mechanism.

## Supply Trade News.

The Phoenix Bridge Company, Phoenixville, Pa., has discontinued its New Orleans, La., branch office and established in its stead an office in the Hurt building at Atlanta, Ga.

The Canadian H. W. Johns-Manville Co., Limited, has moved its Toronto branch to No. 19 Front street, East. The new store and warehouse has a floor area of approximately 35,000 sq. ft. and is situated in the heart of the wholesale district.

The Edison Storage Battery Company, Orange, N. J., has nearly completed its new Orange plant. It is expected that all the new machinery will be received and arranged by the latter part of December, and that an addition of nearly 2,000 new employees will be required to operate it.

The Westinghouse, Church & Kerr Company, of New York, has entered suit in the United States Court at Boston, against the Grand Trunk Railway, alleging breach of contract in connection with the preparations for the construction of a new station at Toronto. The complaint sets forth that plaintiffs have been damaged \$1,000,000 through the railroad company's breach of contract.

The General Electric Company, Schenectady, N. Y., has received among recent orders the following: 55 electro-pneumatic air brake equipments and 101 emergency straight air brake equipments with CP-27 compressors, ordered by the Boston Elevated, Boston, Mass.; eight GE-66, 125 h. p. two-motor, car equipments, ordered by the Northwestern Pacific; and one 40-ton electric switching locomotive of standard construction provided with Sprague-General Electric type M control, geared for slow speed and equipped with four GE-207, 165 a. c., commutating pole motors for operation at 600 v., ordered by the Albany Southern. An order from the Brooklyn Rapid Transit Company is mentioned under Equipment and Supplies.

### TRADE PUBLICATIONS.

**ELECTRIC WELDERS AND GRINDERS.**—The Indianapolis Switch & Frog Company, Springfield, Ohio, has issued a leaflet describing the Indianapolis portable electric welders and grinders.

**BELT SHIFTERS.**—The R. K. LeBlond Machine Tool Company, Cincinnati, Ohio, has issued a booklet entitled, "Safety Commercialized," which is devoted to the LeBlond patent belt shifter.

**DRINKING CUPS.**—The Sanitary Fountain & Vending Machine Company, Pittsburgh, Pa., has issued a six page leaflet describing its collapsible board drinking cups and line of coin operated drinking cup machines.

**STEEL AXLES.**—The Illinois Steel Company, Chicago, Ill., has issued a booklet containing standard dimensions of forged steel axles and the standard specifications relating thereto of the Master Car Builders' Association and those of the company itself.

**HOISTING MACHINERY.**—The Brown Hoisting Machinery Company, Cleveland, Ohio, has issued Catalogue E of its "Brown-hoist" buckets and tubs, describing and illustrating grab buckets, slag buckets, contractors' grab buckets, shovel buckets and various kinds of tubs.

**PORTABLE ACETYLENE LIGHTS.**—The Alexander-Milburn Company, Baltimore, Md., has published a 48 page catalog, describing and illustrating the Milburn portable acetylene lights. The book shows the use for which each light is intended. List prices also are included.

**FUEL OIL SYSTEMS.**—The Gilbert & Barker Manufacturing Company, Springfield, Mass., has issued a catalog, in which it aims to show that by means of its process for burning fuel oil under low pressure, as great efficiency can be obtained as with the use of gas, but at a much lower cost.

**TOOL STEELS.**—E. S. Jackman & Co., Chicago, have published an 80-page booklet devoted to Blue Chip high-speed steel and other tool steels made by the Firth-Sterling Steel Company,

McKeesport, Pa., for which they act as agents. The book shows the use for which each grade of steel is intended and contains list prices.

**LOUISVILLE & NASHVILLE.**—The passenger department of this company has published a small, illustrated booklet, entitled, *Other Things We Do*, which is devoted largely to a brief account of how this railroad builds its own motive power and rolling stock. The illustrations show the various stages of the construction of a locomotive.

**CAR LIGHTING FIXTURES.**—The Dayton Manufacturing Company, Dayton, Ohio, in its catalog No. 166, entitled *Dayton Car Lighting Fixtures*, aims to give one a very complete idea of its line of chandeliers, brackets, etc., for electric, gas and oil systems of lighting. The catalog, which contains over 150 pages, is bound in cloth, and very fully illustrated.

**THREE-PHASE INDUCTION MOTOR PANELS.**—The General Electric Company, Schenectady, N. Y., has just issued bulletin No. A4178, describing its three-phase induction motor panels intended for induction motors of voltages of from 110 to 2,200, and for operation on 25 to 60 cycle circuits. The panels described are single panels only, and not intended to be assembled as parts of a switchboard.

**WATERPROOFING PASTE.**—The Trus-Con Laboratories, Detroit, Mich., have issued a pamphlet giving the results of tests of Trus-Con Waterproofing Paste Concentrated, made at the Royal Testing Laboratories at Berlin, Germany. The results of these severe tests showed that the specimens remained impermeable and the undersides remained dry. The original report of the laboratory is reproduced in full in this bulletin.

**CONCRETE, HIGHWAY AND STREET PAVEMENTS.**—The Universal Portland Cement Company, Chicago, has issued three pamphlets containing specifications for the construction of one-course concrete highways, one-course concrete street pavements and two-course concrete street pavements. These specifications are the result of several years of careful investigation and study of the best type of construction, and embody important points which experience has shown essential to obtaining first class concrete pavements.

**AUTOMATIC SIGNALS.**—The Union Switch & Signal Company, Swissvale, Pa., has devoted bulletin No. 67 to a discussion of its style T-2 automatic block signal. The booklet, which is well illustrated and attractive in appearance, explains the mechanism of the signal, which is of the universal type, in which each semaphore arm is operated by an independent mechanism for all aspects and positions, and is so designed that with slight changes, either direct or alternating current can be used. The illustrations are meant to give one an idea of the several parts of the signal and to explain the proper wiring of its circuits.

**TITANIUM ALLOY IN OPEN HEARTH RAILS.**—The Titanium Alloy Manufacturing Company, Niagara Falls, N. Y., has issued bulletin No. 3 of its series of rail reports. This bulletin is prepared in the same excellent manner that characterizes bulletins Nos. 1 and 2, reviewed in the *Railway Age Gazette* of August 1, page 210, and October 10, page 678. This latest bulletin gives detailed results of a series of seven sets of standard and Titanium treated open hearth rails from which it is observed that the average results of the tensile tests show a much better ductility for the rails treated with Titanium alloy, especially in the heads, and also a slightly increased strength. The impact tests show an average increase of shock resistance of the Titanium treated steel of about 50 per cent. over that of the untreated, while endurance tests indicate that the treated rails are less easily fractured by fatigue or by constantly repeated stresses. Likewise, chemical analyses confirm the claims for Titanium by revealing a greater uniformity in the metal in the treated than in the untreated rails. Several sulphur prints and etched sections, as well as photomicrographs are given, furnishing an instructive comparison from which a reader may draw his own conclusions.

**RAILWAYS OF SALVADOR.**—The Republic of Salvador, with an area of approximately that of the state of New Jersey and with a population estimated at 1,700,000, has 138 miles of railway in operation, all narrow gage and single track.

## Railway Construction.

**BARCLAY & RIVERTON.**—Incorporated in Illinois with \$10,000 capital, to build from the mine of the Barclay Coal Company, east of Springfield, Ill., to a point about one mile east of Riverton, connecting there with the line of the Illinois Traction System. The incorporators include J. W. Black, G. F. Stericker, P. G. Matheny, J. W. Moore and C. A. Lambert, all of Springfield.

**CANADIAN ROADS.**—The Saskatchewan government is being asked to incorporate a company with a capital of \$1,000,000, to build a railway in the provinces of Saskatchewan, Canada. The plans call for building from Regina, Sask., southeasterly to the east boundary of the province, between townships 4, 5 and 6; from Regina northwesterly to townships 27, 28 or 29, ranges 4, 5 or 6, west third meridian, and thence northerly to Saskatoon; from Regina northerly to Prince Albert, and from Saskatoon northeasterly to the east boundary of the province between townships 52, 53 and 54. J. D. McArthur, railway contractor, Winnipeg, Man., is chiefly interested in the project.

**CEDAR RAPIDS & IOWA CITY.**—An officer writes that the company is building with its own forces, an extension from Mt. Vernon, Iowa, to Lisbon, two miles.

**CENTRAL PACIFIC.**—See Southern Pacific.

**CHERRY RIVER & SOUTHERN.**—Incorporated in West Virginia to build from the junction of the Cranberry and Gauley rivers to Ronceverte, Greenbrier county, W. Va., through a lumber region. S. W. Richey, Cincinnati, Ohio, H. L. Kirtley, G. McClintic and W. G. Mathews, Charleston, W. Va., and A. Bringardner, Columbus, Ohio, are incorporators.

**CHICAGO, MILWAUKEE & ST. PAUL.**—An officer writes that work is now under way by Guthrie, McDougall & Company, Portland, Oregon, and the Keasal Construction Company, building the Puget Sound & Willapa Harbor from Maytown, Wash., to Firdale, 54 miles, and from Willapa to Raymond, three miles. (November 14, p. 940.)

**COLUSA & HAMILTON.**—See Southern Pacific.

**GRAND TRUNK PACIFIC.**—An officer writes that work is now under way on the western section as follows: In British Columbia; from Rose Lake to Hutton, 217 miles, contract let to Foley, Welch & Stewart, Winnipeg, Man. In Saskatchewan; Prince Albert branch, 36 miles, and Moose Jaw Northwest branch, 19 miles, contract let to the J. D. MacArthur Co., Winnipeg, Man.; Weyburn branch, 15 miles, contract let to John Bradley, Craven, Sask. In Manitoba, Brandon branch, 26 miles, contract let to Rigby, Hyland & Plummer. (October 17, p. 715.)

**GRANTS PASS-CRESCENT CITY.**—This company was organized in Oregon early this year, with \$5,000,000 capital to build from Grants Pass on the Southern Pacific southwest to Crescent City, Cal., about 100 miles. We are told that the city of Grants Pass has been at work building the first section and has seven miles graded and ready for track laying. Financial arrangements have not yet been made to build the line through to the Pacific coast. L. C. Gilkey, Grants Pass, may be addressed. (April 11, p. 863.)

**HOUSTON & BRAZOS VALLEY.**—An officer writes that work has been finished on the Mound Railway, from Freeport, Tex., to Bryan Heights, 34 miles. This spur line was built to reach the sulphur mines at Bryan Heights, and is now in operation.

**METOLIUS, PRINEVILLE & EASTERN.**—This company will ask for incorporation to build from Metolius, Ore., southeast to Prineville, 30 miles. Most of the right of way and terminal grounds have been secured. H. P. Scheel, treasurer of the Hercules Sandstone Company, operating Tenino quarries, is back of the project.

**MISSOURI, KANSAS & TEXAS.**—The report of this company for the year ended June 30, 1913, shows that during the year the extension of the Wichita Falls Lines from Woodward, Okla., northwest to Forgan, 83.67 miles, was completed, and that the double track work between Waco, Tex., and Hewitt, 7.6 miles, has been completed.

**MOJAVE & BAKERSFIELD.**—See Southern Pacific.

**MOUND RAILWAY.**—See Houston & Brazos Valley.

**NASHVILLE, CHATTANOOGA & ST. LOUIS.**—An officer writes that the company plans to lay second track from Bridgeport, Ala., to Bolivar, 5.4 miles.

**NORTH RAILWAY.**—We are told that this company is now making surveys to build from Montreal, Que., to a connection with the National Transcontinental at Bell river, about 370 miles. T. L. Van Norden, assistant secretary, 95 McGill street, Montreal. (January 24, p. 191.)

**NORTH YAKIMA & VALLEY.**—An officer writes that work on the Cowiche branch which was started last year, is now being carried out by the Valley Construction Company, North Yakima, Wash., on the section from Spitzenburg to the mouth of Cowiche canyon, 2.8 miles, and an extension of this branch is projected to Tieton City, 6.6 miles. In addition the Simcoe branch is projected from Farron to White Swan, 11 miles.

**PITTSBURG, SHAWMUT & NORTHERN.**—An officer writes that work is now under way on an extension from Kittanning, Pa., southwest to Freeport, 17 miles.

**PUGET SOUND & WILLAPA HARBOR.**—See Chicago, Milwaukee & St. Paul.

**QUANAH, ACME & PACIFIC.**—An officer writes that surveys are being made on a section of 50 miles for the extension from Roaring Springs, Tex., southwest in the direction of El Paso. (June 6, p. 1245.)

**SEATTLE, PORT ANGELES & LAKE CRESCENT.**—An officer writes that grading work has been finished from Port Angeles, east on 10 miles, and from Port Angeles west on 15 miles. The line is being built from Oak Bay on Puget sound, in the state of Washington, west into the heavy timber district of the Olympic mountains, about 76 miles, and about 35 miles of the right of way has been secured. A 40-mile extension west has been projected. The Erickson Construction Company has the general contract. The company expects to develop a traffic west of Port Angeles will be ready for operation by the fall of 1914. C. J. Erickson, president, Seattle, and C. P. Donovan, chief engineer, Port Angeles. (September 19, p. 542.)

**SEABOARD AIR LINE.**—The report of this company for the year ended June 30, 1913, shows that an extension from Mulberry, Fla., to Bartow, with a branch to the Royster mine, was completed and is now in operation. In addition 44.05 miles of new sidings and extensions were constructed. The new yards and mechanical facilities at Norlina, N. C., and at Cayce, S. C., have been completed and put in operation, and yard extensions are now in progress at Richmond, Va., Raleigh, N. C., and Hamlet. Work is now under way on double track and revisions of grades from Hamlet, N. C., north on about 9.5 miles.

An officer writes that a contract has been given to Kiblin, Boswell & Company, Dunnellon, Fla., to build an extension from Bartow, Fla., to Pembroke, 8.5 miles.

**SOUTHERN PACIFIC.**—An officer writes that a contract has been given to J. Maney, Colusa, Cal., to build an extension of the Colusa & Hamilton, from Princeton, Cal., to Hamilton, 23.44 miles. A contract has been given to the Utah Construction Company, Ogden, Utah, and San Francisco, Cal., to build an extension of the Central Pacific from a point near Susanville, Cal., to Walker's Mill, 26.82 miles, and the Central Pacific will build 9.12 miles of second track from a point near Magra, Cal., to a point near Colfax. Contracts have been given to the Twohy Brothers Company, Portland, Oregon, and to McArthur Perks Company, Ltd., San Francisco, Cal., to build an extension of the Willamette-Pacific from Noti Creek, Oregon, to Marchfield, 102.32 miles, and surveys have been made to build the Mojave & Bakersfield from Mojave, Cal., northwest to Bakersfield, 85 miles.

**TONOPAH & TIDEWATER.**—This company has applied for permission to issue \$294,000 of bonds for the purpose of constructing a 17-mile narrow gage line from the Ryan branch to borax mines, owned by the Pacific Coast Borax Company in Inyo county, Cal.

**UTAH RAILWAY.**—An officer writes that work is now under way by the Utah Construction Company, Ogden, Utah, building from Black Hawk, Utah, north to Castle Gate, 22 miles, also from Provo south to Thistle, 20.2 miles. In addition surveys are being made from Thistle southeast to Castle Gate, 54 miles.

to connect the two sections now under construction. William Ashton, chief engineer, Salt Lake City, Utah.

**WATAUGA RAILWAY.**—See Watauga & Yadkin River.

**WATAUGA & YADKIN RIVER.**—An officer writes that this company is a consolidation of the Watauga Railway and the Yadkin River Railroad, and now operates 22 miles of road from North Wilkesboro, N. C., where a connection is made with the Southern Railway, west via Grandin. In addition eight miles have been graded from Elkville Junction west to Darby, and a line located from Darby west to Boone, 26 miles. Surveys are now being made from Grandin southwest to Lenoir, 16 miles, and from Boone to Butler, 21.3 miles. H. C. Landon, general manager, North Wilkesboro. (July 4, p. 37.)

**WATERLOO, CEDAR FALLS & NORTHERN (Electric).**—An officer writes that this company finished work during 1913, between La Porte City, Iowa, and Urbana, on 19.9 miles; also between Cedar Falls and Waverly, on 0.15 miles. Contracts have been given to R. A. Elzy, Marshalltown, Iowa, for the grading work and to the Gould Construction Company, Davenport, for the bridge work on an extension from Urbana to Center Point, 5.81 miles. In addition surveys are being made for an extension from Center Point to Cedar Rapids, 17 miles. The company also laid during 1913, 0.63 miles of second track between Cedar Falls and Waverly. (October 3, p. 638.)

**WILLAMETTE-PACIFIC.**—See Southern Pacific.

**YADKIN RIVER.**—See Watauga & Yadkin River.

### RAILWAY STRUCTURES.

**CHICAGO, ILL.**—The Erie has begun work on a new freight house and dock at Webster avenue and the north branch of the Chicago river. Similar structures will also be erected at Erie and Kingsbury streets.

**PARSONS, KAN.**—The report of the Missouri, Kansas & Texas for the year ended June 30, 1913, shows that work is now under way putting up a new passenger station and office building at Parsons, Kan., and a new passenger station at Houston, Tex. During the year stations were completed at Evansville, Mo., Sherman City, Kan., Humbolt, Crowder, Okla., Canadian, Cleveland, Nelagony, Winnsboro, Tex., Newsome, Temple and at Taylor, and extensive changes are being made to the freight station at St. Louis, Mo. Steel bridge work has been installed at several places on the Fort Worth, Houston and San Antonio divisions and on the Texas Central Railroad, replacing pile trestles and steel work of lighter construction; a number of other bridges, including the Missouri river bridge at Boonville, Mo., were strengthened to permit the use of heavier rolling stock. Work is now under way strengthening the bridges between Denison, Tex., and Houston. The Union Terminal Company, of Dallas, which was organized last year, has made good progress in securing land and franchises for a passenger terminal, and plans are now being made for the building and track layout. Work on the Kansas City union station has been delayed by strikes and other causes, but it should be ready for service during the coming year.

**WILMINGTON, N. C.**—The report of the Seaboard Air Line for the year ended June 30, 1913, shows that additional terminal facilities at Wilmington, N. C., at Savannah, Ga., and at Jacksonville, Fla., have been completed. A union passenger station has been finished at Vidalia, Ga., and a union passenger station has been provided at Maxton, N. C. Passenger stations were built at Winsor, Ga., and Sarasota, Fla., and extensive additions and improvements were made to the passenger station at Henderson, S. C. Combination passenger and freight stations were built during the year at Great Falls, S. C., Statham, Ga., and Cussetta, Ga. A brick freight house was built at Monroe, N. C., and work is now under way on one at Charlotte, N. C. At Hutchinson Island, Savannah, Ga., extensive improvements have been made to the terminals, 205,000 sq. ft. of additional cotton sheds were provided, together with the necessary fire walls, two new ship berths with necessary sheds, were also provided on pier two, and three new brick cotton warehouses of 5,000 bales capacity each, were completed.

## Railway Financial News.

**ALABAMA GREAT SOUTHERN.**—The stockholders having approved the issue of \$25,000,000 new first consolidated mortgage bonds, Potter, Choate & Prentice, New York, have bought from the company and will offer for sale \$2,500,000 of these bonds, dated December 1, 1913-1943, at a price to yield 5.10 per cent. on the investment.

**BUFFALO & SUSQUEHANNA.**—Holders of about 95 per cent. of the 4 per cent. bonds of the Buffalo & Susquehanna Railroad have assented to the reorganization plan, and the foreclosure sale was set for December 4. The plan of reorganization provides for an assessment of 10 per cent. on the preferred stock, in exchange for which the preferred stockholder will receive 10 per cent. in new 4 per cent. bonds, 20 per cent. in new 4 per cent. preferred stock, cumulative after 1914, and 30 per cent. in new common.

The company is completing traffic arrangements with the Pennsylvania Railroad.

**MIDDLETOWN & UNIONVILLE.**—Charles I. Henry, president of this company, announces that the Middletown & Unionville has succeeded through foreclosure to the Middletown, Unionville & Water Gap Railroad and will operate it, with general office at Middletown, N. Y. The road extends from Middletown southward, 14.3 miles to State line, a short distance beyond Unionville. Heretofore it has been a part of the New York, Susquehanna & Western, having been operated by that company under an agreement. Combined with a branch of the Susquehanna, this 14-mile road makes a line from Middletown, N. Y., southward to Beaver Lake, Pa., 34 miles, where connection is made with the main line of the Susquehanna. The officers of the new company are: Charles I. Henry, president; Newman Erb, chairman, executive committee; J. A. Smith, vice-president and general manager; B. F. Wollman, general counsel; Garrett T. Townsend, treasurer; Frank H. Finn, secretary; J. W. Goetchins, auditor.

**NATIONAL RAILWAYS OF MEXICO.**—The interest, amounting to \$801,000, due on December 1 on the company's 2-year notes is being paid by the fiscal agents of the company as the coupons are being presented. Arrangements were made for borrowing the money to meet these interest charges from New York and London bankers.

**NEW ORLEANS, TEXAS & MEXICO.**—The report of Y. Van Den Berg, who was employed by the bondholders' protective committee, says in part: "When the lines east of Houston are put in a position to control their share of the established freight and passenger traffic, it is safe to say that at no far distant period thereafter gross earnings will show not less than \$8,000 a mile." The report criticises lack of management on the St. Louis, Brownsville & Mexico, pointing out at the same time that the present general manager has been in charge less than a year and is not, of course, therefore responsible; lack of consistent and constant normal maintenance on the Beaumont, Sour Lake & Western, and more or less haphazard maintenance on the New Orleans, Texas & Mexico. The report recommends the following expenditures to be made over a period of three years, starting at once:

	Betterments.	Equipment.
St. Louis, Brownsville & Mexico.....	\$3,219,240	\$2,235,000
Orange & Northwestern .....	68,000	492,000
Beaumont, Sour Lake & Western.....	532,285	1,252,200
New Orleans, Texas & Mexico.....	1,395,872	.....
Total .....	\$5,215,377	\$3,979,200

**NORTH & SOUTH CAROLINA.**—See Seaboard Air Line.

**ST. LOUIS, ROCKY MOUNTAIN & PACIFIC.**—The New York Stock Exchange has listed \$4,235,000 Bankers Trust Company certificates of deposit for first mortgage 5 per cent. bonds, with authority to add \$7,606,000 on notice of exchange for outstanding bonds. These certificates of deposit represent bonds deposited or those who have consented to the sale, under the agreement previously noted in these columns, to the Atchison, Topeka & Santa Fe.

**SEABOARD AIR LINE.**—This company has an option on the North & South Carolina Railway, which runs from Hamlet, N. C., to Georgetown Junction, S. C., 78 miles.

# ANNUAL REPORTS.

## ANNUAL REPORT OF THE COLORADO & SOUTHERN.

CHICAGO, July 1, 1913.

To the Stockholders of the Colorado & Southern Railway Company:

Herewith is submitted the Fourteenth Annual Report of this Company for the year ended June 30, 1913.

There are included the reports of A. D. Parker, Vice-President, and J. H. Bradbury, General Auditor.

By order of the Board of Directors,

**DARIUS MILLER,**  
President.

DENVER, COLO., July 1, 1913.

**MR. D. MILLER,**  
President,  
Chicago, Ill.

DEAR SIR:—I herewith submit the report for the fiscal year ended June 30, 1913, which report combines the operations and affairs of the lines operated by the companies named, and which are herein designated as the "COLORADO & SOUTHERN LINES."

Per Cent.	1913.	OPERATING REVENUES.	1912.	Per Cent.
71.87	\$10,836,134.18	Freight Revenue	\$ 9,850,048.55	70.56
22.51	3,394,073.63	Passenger Revenue	3,246,772.74	23.26
1.45	218,848.38	Mail Revenue	216,282.70	1.56
1.76	264,279.94	Express Revenue	263,861.93	1.89
		Miscellaneous Transportation Revenue	297,114.93	2.13
1.80	271,113.16	Revenue from Operations other than Transportation	80,750.26	.57
.59	89,542.64	Joint Facilities	5,144.57	.03
.02	3,685.00			
100.00	\$15,077,676.93	Total Operating Revenues	\$13,959,975.68	100.00

OPERATING EXPENSES.				
12.64	\$ 1,905,988.15	Maintenance of Way and Structures	\$ 1,637,316.29	11.73
20.64	3,111,512.80	Maintenance of Equipment	2,532,180.64	18.14
1.53	230,406.63	Traffic Expenses	236,126.75	1.69
32.50	4,901,494.00	Transportation Expenses	4,728,764.59	33.87
3.14	473,560.09	General Expenses	482,065.57	3.45
70.45	\$10,622,961.67	Total Operating Expenses	\$ 9,616,453.84	68.88
29.55	\$ 4,454,715.26	Net Operating Revenue	\$ 4,343,521.84	31.12
	24,804.07	Net Deficit from Outside Operations	24,522.80	
	\$ 4,429,911.19	Total Net Revenue	\$ 4,318,999.04	
	520,546.72	Taxes Accrued	511,470.31	
	\$ 3,909,364.47	Operating Income	\$ 3,807,528.73	

OTHER INCOME.				
	\$ 256,106.51	Rents	\$ 176,946.41	
	588,170.54	Miscellaneous Interest	613,327.89	
	\$ 844,277.05	Total Other Income	\$ 790,274.30	
	\$ 4,753,641.52	Gross Corporate Income	\$ 4,597,803.03	

DEDUCTIONS FROM GROSS CORPORATE INCOME.				
	\$ 141,919.53	Rents	\$ 162,863.55	
	1,203.44	Miscellaneous Interest	887.68	
	2,874,279.94	Interest Accrued on Funded Debt	2,876,854.82	
	10,099.20	Extinguishment of Discount on Securities Sold	8,089.35	
	60,826.48	Sinking Funds	49,140.01	
	\$ 3,088,328.59	Total Deductions	\$ 3,097,835.41	
	\$ 1,665,312.93	Net Corporate Income	\$ 1,499,967.62	
	990,236.92	Dividends	1,300,000.00	
	\$ 675,076.01	Surplus	\$ 199,967.62	

The entire line and physical property of The Colorado Springs & Cripple Creek District Railway has been leased to The Florence & Cripple Creek Railroad Company for a term of years, and the return from this property is treated in this report as rentals received.

The percentage of Operating Revenues required for Operating Expenses was 70.45% as compared with 68.88% in the previous year, and the proportion of Gross Income required for Interest on Funded Debt was 60.46% as compared with 62.57% in the previous year.

During the fiscal year, Refunding and Extension Mortgage Bonds of this Company were issued to cover expenditures for:

Purchase of securities of The Colorado Railroad Company	\$1,010,411.24
And Refunding and Extension Mortgage Bonds were retired from proceeds of sale of securities pledged with the Trustee	28,000.00
First Mortgage Bonds of C. S. & C. C. D. Ry. Co. were retired through Sinking Fund	58,000.00
Deferred Rentals under Equipment Leases were discharged	375,226.18

Making the net increase in Mortgage, Bonded and Secured Debt \$ 549,185.06

The outstanding Capital Stock was reduced by the acquisition of 48.72 shares, par value \$4,872.00, "Stamped Stock," and 7 shares, par value \$700.00, Common Stock of Fort Worth & Denver City Railway Company.

There were charges to Capital Account, aggregating \$616,916.24 for additions and betterments to property. Of this amount, there was expended for:

Structures and Machinery	\$ 93,628.51
Substituting Permanent Bridges for Wooden Ones	94,618.19
Completion New Line—Southern Jct. to Walsenburg Jct.	25,574.21
Completion New Line—Wellington to Cheyenne	43,301.02
Additional Spur and Industry Tracks	19,714.05
Additional Yard Tracks and Sidings	19,091.68
Purchase of Land	31,203.90
Ballast on F. W. & D. C. Ry.	71,765.16
Relaying Heavier Rail—36 Miles Wyoming District	67,717.16
Relaying Heavier Rail—15 Miles Fort Collins District	17,113.47
Various Other Additions and Betterments	133,188.89

The following statistical tables have been compiled in the form required for the Annual Report of Carriers to the Interstate Commerce Commission:

### GENERAL BALANCE SHEET.

JUNE 30, 1913.

#### ASSETS.

Property Investment—Road and Equipment:		
Road	\$94,216,029.13	
Equipment	15,453,944.58	\$109,669,973.71
Reserve for Accrued Depreciation—Credit		2,880,998.70
Total		\$106,788,975.01
Securities:		
Securities of Proprietary, Affiliated and Controlled Companies—Pledged—		
Stocks	\$ 410,308.21	
Funded Debt	8,760,000.00	9,170,308.21
Securities of Proprietary, Affiliated and Controlled Companies—Unpledged—		
Stocks	\$ 108,773.65	
Funded Debt	3,212,321.18	3,321,094.83
Total		\$ 12,491,403.04
Other Investments:		
Advances to Proprietary, Affiliated and Controlled Companies, for Construction Equipment and Betterments	\$ 622,662.80	
Miscellaneous Investments—		
Physical Property	\$ 4,710.00	
Securities Pledged	1,021,557.30	
Securities Unpledged	48,457.40	1,074,724.70
Total		\$ 1,697,387.50
Working Assets:		
Cash	\$ 907,699.97	
Securities Issued or Assumed, Held in Treasuries—		
Funded Debt	4,058,276.55	
Loans and Bills Receivable	7,850.00	
Traffic and Car Service Balances Due from Other Companies	344,158.20	
Net Balance Due from Agents and Conductors	181,885.96	
Miscellaneous Accounts Receivable	360,935.58	
Materials and Supplies	1,363,331.79	
Other Working Assets	8,442.45	
Total		\$ 7,232,580.50
Accrued Income Not Due:		
Unmatured Interest, Dividends and Rents Receivable	\$ 287,743.64	
Deferred Debit Items:		
Advances—		
Temporary Advances to Proprietary, Affiliated and Controlled Companies	\$ 1,500.00	
Working Funds	837.18	
Other Advances	180,900.79	\$ 183,237.97
Rents and Insurance Paid in Advance	22,979.57	
Unextinguished Discount on Funded Debt	224,578.64	
Special Deposits	5,227.71	
Cash and Securities in Sinking Funds	405.85	
Other Deferred Debit Items	120,459.17	
Total		\$ 556,888.91
Grand Total		\$129,054,978.60

#### LIABILITIES.

Capital Stock:		
Common Stock	\$ 31,025,468.00	
Preferred Stock	17,000,000.00	
Total		\$ 48,025,468.00
Mortgage, Bonded and Secured Debt:		
Funded Debt—		
Mortgage Bonds—		
Held by Companies	\$ 4,058,276.55	
Not Held by Companies	61,606,900.00	65,665,176.55
Equipment Trust Obligations	906,452.36	
Total		\$ 66,571,628.91
Working Liabilities:		
Traffic and Car Service Balances Due to Other Companies	\$ 349,573.99	
Audited Vouchers and Wages Unpaid	1,056,871.64	
Matured Interest, Dividends and Rents Unpaid	74,641.42	
Other Working Liabilities	26,000.97	
Total		\$ 1,507,088.02
Accrued Liabilities Not Due:		
Unmatured Interest, Dividends and Rents Payable	\$ 625,639.24	
Taxes Accrued	360,296.31	
Total		\$ 985,935.55
Deferred Credit Items:		
Other Deferred Credit Items	\$ 65,167.36	
Appropriated Surplus:		
Additions to Property since June 30, 1907, through Income	\$ 4,278,090.61	
Reserves from Income or Surplus—		
Invested in Sinking Funds	\$ 29,883.81	
Invested in Road and Equipment	1,589,251.76	
Not Specifically Invested	459,799.03	2,078,934.60
Total		\$ 6,357,025.21
Profit and Loss:		
Balance	\$ 5,542,665.55	
Grand Total		\$129,054,978.60



INCOME STATEMENT.

RAIL OPERATIONS—	
Operating Revenues:	
Revenue from Transportation:	
Freight .....	\$10,836,134.18
Passenger .....	3,394,073.63
Excess Baggage .....	32,999.56
Mail .....	218,848.38
Express .....	264,279.94
Other Passenger Train .....	1,400.08
Switching .....	226,609.83
Special Service Train .....	8,040.43
Miscellaneous Transportation .....	2,063.26
	<b>\$14,984,449.29</b>
Revenue from Operations Other than Transportation:	
Station and Train Privileges .....	\$ 22,444.25
Parcel Room Receipts .....	792.77
Storage Freight .....	2,751.65
Storage Baggage .....	2,515.91
Car Service .....	49,189.67
Rent of Buildings and Other Property .....	5,670.65
Miscellaneous .....	6,177.74
	<b>\$ 89,542.64</b>
Joint Facilities Cr. ....	3,685.00
Total Operating Revenues .....	<b>\$15,077,676.93</b>
Operating Expenses:	
Maintenance of Way and Structures .....	\$ 1,905,988.15
Maintenance of Equipment .....	3,111,512.80
Traffic Expenses .....	230,406.63
Transportation Expenses .....	4,901,494.00
General Expenses .....	473,560.09
	<b>\$10,622,961.67</b>
Net Operating Revenue .....	<b>\$4,454,715.26</b>
OUTSIDE OPERATIONS—	
Revenues .....	\$ 92,788.73
Expenses .....	117,592.80
Net Deficit from Outside Operations .....	<b>\$ 24,804.07</b>
Total Net Revenue .....	<b>\$4,429,911.19</b>
Railway Tax Accruals .....	520,546.72
Railway Operating Income .....	<b>\$3,909,364.47</b>
OTHER INCOME.	
Income from Lease of Road .....	\$ 213,284.97
Joint Facility Rent Income .....	25,286.65
Miscellaneous Rent Income .....	17,534.89
Separately Operated Properties—	
Profit .....	1,301.57

Dividend Income .....	32,060.00
Income from Funded Securities .....	489,233.39
Income from Other Securities and Accounts .....	65,575.58
	<b>\$ 844,277.05</b>
Gross Income .....	<b>\$4,753,641.52</b>

DEDUCTIONS FROM GROSS INCOME.	
Hire of Equipment—Balance .....	\$ 57,330.62
Joint Facility Rent Deductions .....	51,566.25
Miscellaneous Rent Deductions .....	33,022.66
Interest Deductions for Funded Debt .....	2,874,279.94
Other Interest Deductions .....	1,203.44
Amortization of Discount on Funded Debt .....	10,999.20
	<b>\$3,027,502.11</b>

Net Income .....	<b>\$1,726,139.41</b>
------------------	-----------------------

DISPOSITION OF NET INCOME.	
Appropriations of Income to Sinking Funds .....	\$ 60,826.48

Dividend Appropriations of Income:	
Common Stock—	
1 per cent., payable Dec. 31, 1912 .....	310,000.00
First Preferred Stock—	
2 per cent., payable Oct. 1, 1912 .....	\$ 170,000.00
2 per cent., payable Apr. 1, 1913 .....	170,000.00
	<b>340,000.00</b>
Second Preferred Stock—	
2 per cent., payable Oct. 1, 1912 .....	\$ 170,000.00
2 per cent., payable Apr. 1, 1913 .....	170,000.00
	<b>340,000.00</b>
Other Dividends .....	236.92
	<b>\$1,051,063.40</b>
Income Balance Transferred to Credit of Profit and Loss .....	<b>\$ 675,076.01</b>

PROFIT AND LOSS STATEMENT.

Credit:	
Balance June 30, 1912 .....	\$10,661,375.97
Balance for Year brought forward from Income Account .....	675,076.01
Additions for Year:	
Miscellaneous Credits .....	67,066.43
	<b>\$11,403,518.41</b>
Debit:	
Appropriations of Surplus .....	\$ 5,839,462.62
Deductions for Year:	
Miscellaneous Debits .....	21,390.24
	<b>\$ 5,860,852.86</b>
Balance Credit, June 30, 1913 .....	<b>\$ 5,542,665.55</b>

REPORT OF THE DIRECTORS OF THE SEABOARD AIR LINE RAILWAY FOR THE FISCAL YEAR ENDED JUNE 30, 1913.

PORTSMOUTH, VA., October 23rd, 1913.

To the Stockholders of the Seaboard Air Line Railway:  
The Board of Directors submits the following report of the operations of the property for the year ended June 30, 1913:

INCOME ACCOUNT FOR YEAR ENDED JUNE 30, 1913.

	1913	1912	Increase
Gross Revenue .....	\$24,527,864.62	\$22,921,903.98	\$1,605,960.64
Operating Expenses and Taxes .....	17,681,612.65	17,197,086.81	484,525.84
Net Operating Revenue .....	\$ 6,846,251.97	\$ 5,724,817.17	\$1,121,434.80
Outside Operations .....	(Dr.) 26,314.12	(Dr.) 22,686.02	3,628.10
Operating Income .....	\$ 6,819,937.85	\$ 5,702,131.15	\$1,117,806.70
Other Income .....	220,063.88	183,377.70	36,686.18
Gross Income .....	\$ 7,040,001.73	\$ 5,885,508.85	\$1,154,492.88
Rentals and Hire of Equipment .....	397,589.17	361,337.37	36,251.80
Applicable to Interest .....	\$ 6,642,412.56	\$ 5,524,171.48	\$1,118,241.08
Fixed Interest Charges .....	3,656,558.89	3,460,727.17	195,831.72
Balance .....	\$ 2,985,853.67	\$ 2,063,444.31	\$ 922,409.36
Full 5% Interest on Adjustment (Income) Bonds .....	1,250,000.00	1,249,658.34	341.66
Net Income .....	\$ 1,735,853.67	\$ 813,785.97	\$ 922,067.70

The Gross Revenue increased 7.01 per cent., Operating Expenses and Taxes increased 2.82 per cent., and Operating Income increased 19.59 per cent.

The Operating Expenses, exclusive of Taxes were 68.19 per cent. of the Gross Revenue, as compared with 71.02 per cent. the previous year; and including Taxes, 72.09 per cent. of Gross Revenue as compared with 75.02 per cent. for the preceding year.

MILEAGE OPERATED.

The mileage of the Seaboard Air Line Railway in operation on June 30, 1912, was .....	3,070.12
Extensions, etc., constructed during the year .....	11.86

Mileage in operation June 30, 1913 .....	3,081.98
Made up as follows:	

MILEAGE OWNED.

Seaboard Air Line Railway and branches .....	3,016.39
--	----------

LEASED LINES.

Meltrim, Ga., to Lyons, Ga. ....	57.65
----------------------------------	-------

TRACKAGE.

Howells, Ga., to Atlanta, Ga. ....	3.00
Hilton, N. C., to Navassa, N. C. ....	2.40
In Birmingham, Ala., and vicinity .....	15.11
Near Mulberry, Fla. ....	1.46
	<b>79.62</b>

3,096.01

DEDUCT.

Amelia Beach branch, leased to Street Railway Company at Fernandina, Fla. ....	2.00
Gibson, N. C., branch, leased to the North & South Carolina Railway .....	10.13
Silver Springs, Fla., branch, leased to the Ocala Northern Railway .....	1.90
	<b>14.03</b>
Total mileage operated June 30, 1913 .....	3,081.98
Sidings (including 19.29 miles on Leased Lines and Trackage) .....	817.52
Average miles of road operated during the year .....	3,073.58
Average miles of road operated shows an increase over previous year of .....	00.49%

CAPITAL STOCK.

There has been no change in the capital stock during the year.

MORTGAGE, BONDED AND SECURED DEBT.

During the year \$800,000 par value 4% Refunding Bonds were issued in reimbursement of expenditures made to retire equipment trust obligations and sold, making a total of \$23,800,000 par value of 4% Refunding Bonds outstanding on June 30, 1913.

An issue of \$6,000,000 par value of Three Years 5% Gold Notes, dated March 1, 1913, payable March 1, 1916, redeemable in whole or in part at par and accrued interest, secured by the pledge of 4% Refunding Bonds of the Company, were sold during the year for the purpose of providing funds for additions, betterments and improvements to the property and for the retirement of temporary obligations, the proceeds of which had been similarly used. Of said notes \$5,000,000 par value were delivered up to June 30, 1913, leaving \$1,000,000 for later delivery. For further details of the Company's funded debt see Table No. 4.

EQUIPMENT.

An Equipment Agreement, Series "O," was entered into on July 15th, 1912, for the purchase of:

- 5 Passenger Locomotives,
- 15 Freight Locomotives,
- 5 Switching Locomotives,
- 1 Dummy Locomotive,
- 10 All Steel Passenger Coaches,
- 7 All Steel Mail and Baggage Cars,
- 7 All Steel Passenger and Baggage Cars,
- 3 All Steel Express Cars,
- 6 All Steel Dining Cars,
- 1000 Steel Upper and Under Frame Ventilated Box Cars,
- 200 All Steel Coal Cars,
- 25 Steel Under Frame Caboose Cars,
- 2 Wrecking Cranes,

for which \$240,581.42 was paid in cash and equipment trust obligations aggregating \$2,060,000 were issued, payable in twenty consecutive semi-annual instalments of \$103,000 each, bearing interest at the rate of 4 1/4% per annum. All of this equipment was received during the fiscal year except the following:

- 7 Mail and Baggage Cars,
- 4 Passenger and Baggage Cars.

There was built during the year at Portsmouth Shops, and put in service to replace Trust Equipment destroyed:

1 Steel Express Car

In addition to the equipment named above, the following were purchased:

- 1 Steam Ditcher,
1 Ballast Spreader Car,
1 Car Float,
1 Ferry Boat,

all of which have been received.

EXTENSIONS.

An extension to the Company's line in Florida, from Mulberry to Bartow, with a branch line to the Royster Mine, mentioned in last year's report was completed and put in operation March 15, 1913—11.86 miles.

MAINTENANCE OF WAY AND STRUCTURES. ROADWAY, TRACK AND STRUCTURES.

Roadway, track and structures of the railway have been maintained at a cost of \$3,014,956.54, which represents an expenditure per mile of road of \$980.93.

SIDE TRACKS.

44.05 miles of new sidings and extensions of existing sidings were constructed, and there were deducted by removal and changes of old sidings 3.79 miles, making a net increase over previous year of 40.26 miles.

There were also constructed 0.14 mile of new sidings and extensions of existing sidings on leased lines.

TIE RENEWALS.

The tie renewals were 1,267,705 cross ties and 924 sets of switch ties, and the cost, \$533,761.70, was charged to Operating Expenses.

NEW RAIL.

130.05 miles of new 75-pound and 1.01 miles 75-pound steel rail making a total of 131.06 miles were laid in the main line track, releasing therefrom 58, 60, 60.5, 70, 75 and 80-pound worn rail, and there was charged net to Operating Expenses \$62,857.00 and to Capital Account \$101,407.05.

BALLAST.

189,480 cubic yards of gravel and slag ballast were put under main line track at a cost of \$155,018.59, of which \$138,921.88 was charged to Capital Account and \$16,096.71 to Operating Expenses.

TRESTLES FILLED.

6,432 lineal feet of wooden trestles were filled in, and of the total cost thereof, including culverts, \$42,266.09 was charged to Operating Expenses.

TRESTLES REBUILT AND BALLAST DECKED.

There were built during the year with creosoted timber 5,804 lineal feet of trestles, which have been ballast decked at a cost of \$60,477.14, which was charged to Operating Expenses.

TRESTLES STRENGTHENED.

Additional stringers were put in 107 trestles during the year to strengthen same to carry heavier power.

BRIDGES.

Work has been done on thirty-nine bridges, replacing with steel or strengthening them for heavy power. Of this number, twenty-four have been completed, and the remaining fifteen will be finished by June 30th, 1914.

Fifteen of the above bridges were authorized during this year and two of the fifteen have been completed.

Of the bridges completed the principal ones are:

Table with 2 columns: Bridge Name and Length. Includes Richmond Viaduct, A. C. L. R. R. Underpass near Chester, Va., McAlpin Creek, near Mathews, N. C., Savannah River, near Cloy, Ga., College Street, Cedartown, Ga., and Main Street, Abbeville, S. C.

The total expenditures for bridge renewals during the year were \$192,315.46, of which \$180,881.06 was charged to Capital Account and \$11,434.40 to Operating Expenses.

RAIL IN MAIN LINE TRACK.

Of the total operated main line mileage of the system, 3,081.75 miles are laid with steel rails and 0.23 miles with iron rails. The steel rail is made up as follows:

Table with 2 columns: Miles and Weight. Lists various rail types and their weights, including 85 lb. rail, 80 lb. rail, 75 lb. rail, etc.

The above does not include 2.00 miles of Amelia Beach Branch, leased to Street Railway at Fernandina, Fla.; 10.13 miles of Gibson Branch, leased to North & South Carolina Railway Company; or 1.90 miles of Silver Springs Branch, leased to Ocala Northern Railway.

MAINTENANCE OF EQUIPMENT.

The equipment of the Railway was maintained during the year at a cost of \$3,338,541.64.

Included in the cost of maintenance is \$113,690.08, representing value of equipment destroyed or retired from service during the year, and credited to Cost of Equipment.

There were also included in the cost of maintenance \$344,689.49 for depreciation, which was credited to Reserve for Accrued Depreciation.

Table with 2 columns: Description and Cost. Shows average cost per annum per Locomotive owned (\$2,557.06), Passenger car owned (808.79), and Freight car owned (59.90).

GENERAL REMARKS.

The permanent way and equipment have not only been fully maintained, but in addition thereto there has been a betterment in condition in line with a policy which has been adopted of steadily improving the property. As a result of this policy and with the completion of the extensive bridge program, including the filling of trestles, which has been under way, together with other similar permanent improvements, it has been possible during the past year to make a substantial reduction in Maintenance of Way and Structures.

The additional terminal facilities at Wilmington, Savannah and Jacksonville, referred to in the last annual report, have been completed.

The union passenger station at Vidalia, Ga., mentioned in the last annual report, has been completed. A union passenger station has been provided at Maxton, N. C.

Passenger stations have been built at Winder, Ga., and Sarasota, Fla., and extensive additions and improvements have been made to the passenger station at Henderson, N. C.

Combination passenger and freight stations have been constructed during the year at Great Falls, S. C., Statham, Ga., and Cussetta, Ga.

A brick freight depot has been built at Monroe, N. C., and one is now in process of construction at Charlotte, N. C.

The new yards and mechanical facilities at Norlina, N. C., and Cayce, S. C., referred to in the last annual report, have been completed and put in operation.

Yard extensions are now in process of construction at Richmond, Va., Raleigh, N. C., and Hamlet, N. C., and at the last named place are about completed.

Water stations and pumping facilities have been provided at Norlina, N. C., and McKenny, Va., and work has been started to supply suitable water facilities at Apex, N. C.

A mechanical coal elevator is under construction at Richland, Ga., and a coal storage plant of approximately fifteen thousand tons capacity is under construction at Savannah, Ga. The coal storage plant at Jacksonville, Fla., is being extended in order to increase its capacity to fifteen thousand tons.

Turntables, eighty-five feet long have been installed at Cayce, S. C., and at Norlina, N. C. The installation of an eighty-five foot turntable is now in progress at Hamlet, N. C.

At Hutchinson Island, Savannah, Ga., extensive improvements have been made to the Terminals. Two hundred and five thousand square feet of additional cotton sheds were provided, together with the necessary fire walls, two new ship berths with necessary sheds for accumulating cargo were provided on Pier Two, and three new brick cotton warehouses of 5,000 bales capacity each, were completed. Additional tracks are under construction, and in connection with the Atlantic Compress Company, a change is being made in the location of the compresses which will make available for the Railway's use 135,000 square feet of additional shed room for the coming season, 5,340 square yards of brick cotton platform have been laid at a cost of \$3,204.00, which was charged to Operating Expenses, to replace worn out wooden platforms.

At Seddon Island, Tampa, Fla., there is now in course of construction a steel phosphate elevator with two conveyors, each having a capacity of three hundred tons per hour. The necessary tracks, wharf, dredging, etc., are included in this work.

Work is now in progress on double track and revision of grade from Hamlet, N. C., northward about nine and one-half miles, which will provide a five-tenths per cent. compensated grade line thereon. This work will fit in with and form a part of a comprehensive plan which has been made for the ultimate development of the line between Norlina and Hamlet, North Carolina.

Six old twenty-thousand gallon water stations have been replaced with fifty-thousand gallon tanks, and suitable pumping facilities have been provided.

The use of creosoted piling has been continued in maintenance work on docks, wharves, and trestles. The work on the Maxwell lumber dock at Jacksonville, Fla., was completed during the year.

Eight track scales have been rebuilt with concrete foundations and steel I-beams, replacing wood.

213 industrial sidings and extensions to industrial sidings already existing have been constructed or are in process of construction.

67 depots and freight stations have been constructed or substantially added to during the year.

55 passing tracks have been constructed or extended, or are in process of construction.

During the year there have been constructed and placed in operation, 285 miles additional telephone circuits between Columbia, S. C., and West Jacksonville, Fla. This aggregates 1,374 miles in operation June 30, 1913.

The parcel post, inaugurated January 1, 1913, has greatly added to the volume and weight of the mail handled, thereby adding to the cost of handling, for which up to the close of the fiscal year the company had received no revenue. This service has also tended to decrease the normal increase in revenue received from express business, thus working a double loss to the railway. Everything possible is being done to secure from the Government adequate compensation for this increase in mail handled.

The accounts for the fiscal year were examined by Messrs. Haskins and Sells, whose certificate appears on page 10.

CHANGES IN ORGANIZATION.

Mr. N. S. Meldrum having resigned as President, Mr. W. J. Harahan was elected, effective September 26th, 1912.

Mr. C. H. Hix, Vice-President and General Manager, resigned, effective November 1st, 1912, to accept service with another Company.

Mr. E. D. Kyle having resigned to accept service with another Company, effective November 1, 1912, Mr. L. E. Chalenor was appointed Freight Traffic Manager.

Mr. W. L. Seddon was appointed Assistant to the President, and Mr. W. D. Faucette was appointed Chief Engineer, effective January 1st, 1913.

Mr. T. W. Roby, Comptroller, died on February 7th, and Mr. H. W. MacKenzie was elected Comptroller February 19th, 1913.

Mr. A. J. Poole having resigned, effective April 5th, 1913, Mr. J. W. Small was appointed Superintendent Motive Power.

Mr. H. W. Stanley was appointed General Manager, effective May 1st, 1913.

The death of the Comptroller, Mr. Thomas Walton Roby, which occurred February 7th, 1913, is recorded with deep sorrow and regret. Mr. Roby entered the Railroad employ with one of the predecessor companies of the Seaboard Air Line Railway, in 1878, and was an active and efficient officer during his entire thirty-five years of service.

The Board records its appreciation of the loyal and efficient services rendered by the officers and employes of your Company during the year. By order of the Board: W. J. HARAHAN, President.

TABLE No. 10.  
TRAFFIC STATISTICS.

YEAR ENDED JUNE 30, 1913, COMPARED WITH YEAR ENDED JUNE 30, 1912.			
	1913.	1912.	INCREASE OR DECREASE.
Average miles operated.....	3,073.58	3,058.63	14.95
<b>FREIGHT TRAFFIC.</b>			
<b>REVENUE FREIGHT.</b>			
Number of tons carried.....	10,409,242	9,406,877	1,002,365
Number of tons carried one mile.....	1,538,446,241	1,390,977,614	147,468,627
Number of tons carried one mile per mile of road.....	500,539	454,771	45,768
Average distance hauled each ton.....	147.80	147.87	-.07
Total Freight Train Revenue.....	\$16,788,111.56	\$15,433,239.16	\$1,354,872.40
Average amount received from each ton.....	\$1.61.281	\$1.64.063	-\$0.2.782
Average receipt per ton per mile.....	\$0.1.091	\$0.1.110	-\$0.0.019
Freight Train Revenue per mile of road.....	\$5,462.07	\$5,045.80	\$416.27
Freight Train Revenue per train mile.....	\$2.68.352	\$2.63.200	\$0.05,152
Average number of tons per train mile.....	245.91	237.22	8.69
Average number of tons per loaded car mile.....	15.09	14.87	.22
<b>ALL FREIGHT</b>			
(Including Company's Material, hauled free).			
Number of tons carried.....	12,093,055	10,897,475	1,195,580
Number of tons carried one mile.....	1,729,894,658	1,575,592,671	154,301,987
Average number of tons per train mile.....	276.52	267.98	8.54
Average number of tons per loaded car mile.....	16.96	16.84	.12
<b>PASSENGER TRAFFIC.</b>			
Number of Passengers carried.....	4,928,125	4,870,104	58,021
Number of Passengers carried one mile.....	237,424,214	231,202,542	6,221,672
Number of Passengers carried one mile per mile of road.....	77,247	75,590	1,657
Average distance carried each Passenger.....	48.18	47.47	.71
Total Revenue from Passengers..	\$5,221,199.82	\$5,050,067.90	\$171,131.92
Average Amount received from each Passenger.....	\$1.05.947	\$1.03.695	\$0.2.252
Average receipt per Passenger per mile.....	\$0.2.199	\$0.2.184	\$0.0.015
Passenger Revenue per train mile.....	\$91.760	\$92.398	-\$0.638
Total Passenger Train Revenue..	\$6,654,615.17	\$6,401,739.53	\$252,875.64
Passenger Train Revenue per mile of road.....	\$2,165.10	\$2,093.01	\$72.09
Passenger Train Revenue per train mile.....	\$1.16.951	\$1.17.435	-\$0.484
Average number of Passengers per train mile.....	41.73	42.41	-.68
Average number of Passengers per car mile.....	7.93	7.88	.05

REVENUE AND OPERATING EXPENSES.

Passenger and Freight Train Revenue.....	\$23,442,726.73	\$21,834,978.69	\$1,607,748.04
Passenger and Freight Train Revenue per mile of road.....	\$7,627.17	\$7,138.81	\$488.36
Gross Revenue.....	\$24,527,864.62	\$22,921,903.98	\$1,605,960.64
Gross Revenue per mile of road.....	\$7,980.23	\$7,494.17	\$486.06
Gross Revenue per train mile.....	\$2.04.995	\$2.02.274	\$0.2.721
Operating Expenses.....	\$16,725,612.65	\$16,280,086.81	\$445,525.84
Operating Expenses per mile of road.....	\$5,441.74	\$5,322.67	\$119.07
Operating Expenses per train mile.....	\$1.39.786	\$1.43.663	-\$0.3.877
Net Operating Revenue.....	\$7,802,251.97	\$6,641,817.17	\$1,160,434.80
Net Operating Revenue per mile of road.....	\$2,538.49	\$2,171.50	\$366.99
Net Operating Revenue per train mile.....	\$65.209	\$58.611	\$6.596

TABLE No. 11.  
FREIGHT TRAFFIC STATISTICS, BY MONTHS.  
YEAR ENDED JUNE 30, 1913.

MONTHS	Number of Tons	Number of Tons One Mile	Freight Revenue	Average Rate Per Ton (Cents)	Average Distance Hauled (Miles)
July.....1912	747,495	108,537,815	\$1,119,918.59	01.032	145.20
August.....	784,576	109,501,750	1,122,310.97	01.025	139.56
September.....	751,872	105,362,250	1,176,885.13	01.117	140.13
October.....	928,709	135,119,213	1,535,576.47	01.136	145.49
November.....	901,937	128,820,585	1,488,498.01	01.115	142.83
December.....	846,524	130,448,496	1,467,337.89	01.125	154.10
January.....1913	920,540	138,437,730	1,481,955.59	01.070	150.39
February.....	843,385	125,860,514	1,479,172.80	01.175	149.23
March.....	1,031,379	145,479,904	1,646,018.80	01.131	141.05
April.....	952,653	137,467,010	1,470,362.39	01.070	144.30
May.....	874,374	140,804,610	1,456,418.61	01.034	161.03
June.....	825,798	132,606,364	1,343,656.31	01.013	160.58
TOTAL FOR YEAR 1913	10,409,242	1,538,446,241	\$16,788,111.56	01.091	147.80
TOTAL FOR YEAR 1912	9,406,877	1,390,977,614	\$15,433,239.16	01.110	147.87
Increase.....	1,002,365	147,468,627	\$1,354,872.40	.....	.....
Per Cent of Increase.....	10.66	10.60	08.78	.....	.....
Decrease.....	.....	.....	.....	00.019	.07
Per Cent of Decrease.....	.....	.....	.....	01.71	00.05

TABLE NO. 9.  
EXPENDITURES FOR IMPROVEMENTS, BETTERMENTS AND EXTENSIONS CHARGED TO CAPITAL ACCOUNT.  
YEAR ENDED JUNE 30, 1913.

SUMMARY OF EXPENDITURES:	
Additions and Betterments on Existing Mileage.....	\$1,685,254.00
Equipment Acquired.....	1,931,994.23
Expenditures for Extensions.....	41,803.46
<b>TOTAL AS ABOVE.....</b>	<b>\$3,659,051.77</b>

MISSOURI, KANSAS & TEXAS RAILWAY COMPANY ANNUAL REPORT.

St. Louis, Mo., October 29, 1913.

To the Stockholders of  
Missouri, Kansas & Texas Railway Company:  
The directors and officers of your Company submit herewith their report for the fiscal year ended June 30, 1913.  
The operations of the Lines named  
Missouri, Kansas & Texas Railway Company.....1,744.41  
The Missouri, Kansas & Texas Railway Company of Texas.....1,293.78  
Texas Central Railroad Company.....308.72  
The Denison, Bonham & New Orleans Railroad Company.....24.15  
The Dallas, Cleburne & Southwestern Railway Company.....9.82  
Missouri, Kansas & Texas Terminal Company of St. Louis.....  
Wichita Falls & Northwestern Railway Company.....328.68  
Wichita Falls & Northwestern Railway Company of Texas.....18.02  
Wichita Falls & Wellington Railway Company of Texas.....15.00  
Wichita Falls & Southern Railway Company.....56.21  
Wichita Falls Railway Company.....17.98  
Total miles operated June 30, 1913.....3,816.77  
were as follows:

RESULTS FOR THE YEAR.

(Includes eight months' operation of Wichita Falls Lines, from November 1, 1912. Intercorporate income items are excluded.)	
Operating Revenues were.....	\$32,346,258.39
(Increase.....\$4,159,539.28 or 15%)	
Operating Expenses were.....	22,808,412.39
(Increase.....\$1,602,563.69 or 8%)	
Net Operating Revenue was.....	\$ 9,537,846.00
(Increase.....\$2,556,975.59 or 37%)	
Taxes were.....	1,287,903.29
(Increase.....\$ 227,721.82 or 21%)	
Operating Income, Taxes deducted, was.....	\$ 8,249,942.71
(Increase.....\$2,329,253.77 or 28%)	
Miscellaneous Income was.....	666,611.06
(Increase.....\$ 310,215.39 or 87%)	
Rentals and other Payments were.....	\$ 8,916,553.77
(Increase.....\$ 6,999.86 or 1%)	
Income for the year available for Interest was.....	\$ 8,295,180.22
(Increase.....\$2,632,469.30 or 46%)	
Interest (72% of amount available) amounted to.....	5,978,194.75
(Increase.....\$ 332,652.04 or 6%)	
Net Income for the year amounted to.....	\$ 2,316,985.47
(Increase.....\$2,299,817.26)	

Dividends declared during the year:  
M., K. & T. Ry. Co. Preferred Stock (4%)..\$520,000.00  
Texas Central R. R. Co. Stock outstanding (5%).....1,010.00  
Wichita Falls & Northwestern Ry. Co. Stock outstanding (6%).....42.00 521,052.00  
Remainder, devoted to improvement of physical and other assets (equivalent to 2.84% on M., K. & T. Ry. Co. Common Stock).....\$ 1,795,933.47

MILEAGE.

The average mileage operated during the year was 3,677.47, an increase over the previous year of 279.28 miles.  
The total mileage operated on June 30, 1913, increased 417.91 miles as compared with the mileage operated June 30, 1912, as follows:  
Wichita Falls, Texas, to Red River.....18.02 miles  
Red River to Forgan, Oklahoma.....286.78 "  
Altus, Oklahoma, to Wellington, Texas.....56.90 "  
Wichita Falls to Newcastle, Texas.....56.21 "  
Total.....417.91 miles

OPERATIONS.

The gross and net earnings were the largest in your Company's history. The surplus, after payment of all charges, was larger than any previous year except 1907. Improved business conditions generally in the South-west and increased passenger travel contributed to swell the revenue, while favorable operating conditions during the year enabled the traffic to be handled with a relatively small increase in operating expenses. Operating expenses were increased largely because of heavier traffic, higher standards of maintenance and additional mileage operated. The ratio of expenses to earnings was 70.51% as compared with 75.23% in the previous year. While operating revenues increased \$4,159,539.28, or 15%, transportation expenses increased only \$608,272.51, or 5%.

FINANCIAL.

The changes in outstanding capital stock during the year, as shown by the balance sheet, were as follows:

	Increase.	Decrease.
Boonville Railroad Bridge Co.....	\$ 600.00	
Missouri, Kansas & Texas Terminal Co. of St. Louis.....	900.00	
Texas Central R. R. Co., Preferred.....		\$ 5,000.00
Texas Central R. R. Co., Common.....		10,000.00

Wichita Falls & Northwestern Ry. Co.....	700.00
Wichita Falls & Southern Ry. Co.....	900.00
Wichita Falls & Wellington Ry. Co. of Texas.....	700.00
Wichita Falls & Northwestern Ry. Co. of Texas.....	700.00
Wichita Falls Railway Co.....	700.00

Net decrease ..... \$5,200.00 \$15,000.00  
 \$ 9,800.00

The changes in funded debt in the hands of the public during the year were as follows:

	Increase.	Decrease.
M., K. & T. Ry. Co. Two-Year 5% Secured Gold Notes.....	\$19,000,000	
M., K. & T. Ry. Co. 5% Equipment Notes.....	1,900,000	
M., K. & T. Ry. Co. One-Year 5% Secured Gold Notes (Issued July 1, 1912, redeemed May 1, 1913).....	1,500,000	\$ 1,500,000
W. F. & N. W. Ry. Co. 1st and Refunding Mortgage 5% Bonds.....	500,000	
Katy Office Building Co. 1st Mortgage 5 1/4% Bonds.....	200,000	
M., K. & T. Ry. Co. Two-Year 5% Secured Gold Notes.....		16,000,000
M., K. & T. Ry. Co. 5% Secured Notes.....		1,100,000
Boonville R. R. Bridge Co. 1st Mortgage 5% Bonds.....		12,000
Net Increase.....	\$23,100,000	\$18,612,000
	\$ 4,488,000	

(from which \$508,000 General Mortgage 4 1/2% Gold Bonds purchased for the Sinking Fund and held by the Trustee may be deducted.)

Other changes in funded debt, as shown by the condensed balance sheet of June 30, 1913, published on pages 20 and 21, hercof, were:

	Increase.
M. K. & T. Ry. Co. Consolidated Mortgage 5% Bonds (see page 7).....	\$3,146,000.00
W. F. & N. W. Ry. Co. 1st Mortgage 5% Bonds.....	2,213,000.00
W. F. & N. W. Ry. Co. 1st Lien Collateral Trust Mortgage 5% Bonds.....	873,000.00
W. F. & N. W. Ry. Co. 1st and Refunding Mortgage 5% Bonds.....	2,500,000.00
W. F. & So. Ry. Co. 1st Mortgage 5% Bonds.....	749,000.00
W. F. & N. W. Ry. Co. Equipment Trust Notes.....	56,490.97

Net Increase ..... \$9,537,490.97

\$19,000,000 two-year 5% gold notes, part of an authorized issue of \$25,000,000, dated May 1, 1913, due May 1, 1915, were sold during the year, the proceeds of which were used to refund \$16,000,000 two-year notes, falling due May 1, and \$1,500,000 one-year notes, due July 1 but called for payment May 1, and for additions to property. The present issue of \$19,000,000 of these notes is secured by \$24,516,000 face amount of Missouri, Kansas & Texas Railway Company consolidated mortgage 5% Gold Bonds.

It was also found advisable to create an equipment trust for \$1,900,000, dated June 2, 1913, covering new equipment costing \$2,376,940.65. The equipment trust notes bear 5% interest, and mature \$95,000 semi-annually on June 1 and December 1 until 1923.

\$3,146,000 Missouri, Kansas & Texas Railway Company Consolidated Mortgage 5% Gold Bonds were authenticated under the mortgage and delivered to your Company during the year as follows:

In reimbursement of expenditures made for additions and betterments.....	\$1,356,000
In reimbursement of expenditures made for new equipment.....	802,000
Against M., K. & T. Ry. Co. General Mortgage Bonds retired by Sinking Fund.....	508,000
Against Boonville Railroad Bridge Company First Mortgage Bonds retired by Sinking Fund.....	9,000
Against the pledge of First and Refunding Mortgage Bonds of Wichita Falls & Northwestern Railway Company acquired during the year.....	374,000
Against the pledge of Beaumont & Great Northern Railroad Stock acquired during the year.....	54,000
Against the pledge of First Mortgage Bonds of Missouri, Kansas & Texas Terminal Company of St. Louis, acquired during the year.....	43,000
Total.....	\$3,146,000

Of the above mentioned Consolidated Mortgage bonds, \$184,000 were on June 30, 1913, in your Company's treasury, \$2,058,000 were pledged under the two-year notes maturing May 1, 1915, and \$904,000 were pledged to secure bills payable.

WICHITA FALLS LINES.

The acquisition of the capital stock of these companies was discussed at length in last year's annual report. The extension of 83.67 miles from Woodward to Forgan, then under construction, was completed in October last, and since November 1, 1912, the income of these lines has been included with all other lines reported. These lines have proved to be valuable feeders of traffic.

BEAUMONT & GREAT NORTHERN RAILROAD HOUSTON & BRAZOS VALLEY RAILWAY COMPANY.

In accordance with a policy of conservative expansion to aid in the development of a constant traffic moving northward, your Company purchased during the year the entire capital stock of the Beaumont & Great Northern Railroad, which owns a line extending through the lumber district of East Texas from Livingston to Weldon, a distance of 48.3 miles, and which connects at Trinity with what is known as the Trinity Division of the Missouri, Kansas & Texas Railway of Texas; and one-half of the capital stock of the Houston & Brazos Valley Railway Company, which operates about 24 miles of road extending from Anchor to Velasco and Freeport, Texas, on the Gulf of Mexico at the mouth of the Brazos River.

The Beaumont & Great Northern Railroad has \$50,000 capital stock and \$883,000 of First Mortgage 5% bonds, and your Company has guaranteed the payment of principal and interest of the bonds. There is a considerable movement of tonnage from the Beaumont & Great Northern Railroad, but the full benefit of its acquisition will not be derived until a connection with the main line has been built, when the mileage and the operation of the line will be included in reports.

The Houston & Brazos Valley Railway Company has \$24,000 capital stock and \$420,000 First Mortgage 5% bonds. Your Company has guaranteed principal and interest of \$210,000 face amount of these bonds and has purchased an additional \$92,000 face amount of them.

Freeport is a new port in process of development by a syndicate of bankers who have made heavy investments there, particularly in the installation of a plant to mine sulphur (of which large deposits have been discovered in the vicinity) by the hot water process, and who own the remaining one-half of the capital stock of Houston & Brazos Valley Railway Company. The syndicate has also planned important industrial

developments at Freeport, and, in addition to the traffic incident thereto and the sulphur tonnage, a substantial interchange of traffic with steamship lines is expected eventually to develop. The Seaboard & Gulf Steamship Company is now operating semi-monthly service between New York and Freeport. This transaction has also resulted in the acquisition by the Brazos Warehouse Company, the capital stock of which is owned by your Company, of 634 acres of land on the river front at Freeport.

ROLLING STOCK.

The equipment inventory as of June 30, 1913, was as follows:

Locomotives.....	682	Increase 54
Passenger-Train Cars.....	493	Increase 15
Freight-Train and Miscellaneous Cars owned and leased.....	26,872	Increase 858

The average amounts expended for repairs to equipment in service were:

	Increase.	Decrease.	Per Cent.
Locomotives.....	\$2,422.08	\$367.34	13.17
Passenger-Train Cars.....	777.67	\$218.41	39.05
Freight-Train Cars.....	53.71	9.99	22.85

42 locomotives, or 6% of the number owned, and 750 freight cars, or 2.9% of the number owned, were undergoing or awaiting heavy repairs at the close of the year.

The average tractive power of locomotives in service increased 1752 pounds or 6.66%. The average capacity of freight cars in service increased 290 pounds, or .5%.

There was expended during the year for the purchase of equipment, less the value of equipment retired, a net amount of \$1,506,667.35.

ROADWAY AND STRUCTURES.

The roadway has been fully maintained. The expenditure for permanent additions and betterments, exclusive of equipment, aggregated \$2,454,801.74, a statement of which appears on page 22.

Considerable headway has been made in general improvement work, from the standpoint of securing additional revenue and of effecting economies in operation.

The policy of renewing with heavier steel the light rail on the various portions of the line has been continued, a total of 155 miles of new 85 lb. rail having been laid during the year.

In pursuance of the general plan of renewing wooden trestles and culverts in concrete, 450 structures of this character have been so renewed, a total of 20,220 cubic yards of concrete having been used; and considerable concrete abutment work in connection with steel bridges has been done.

Steel bridge work has been installed at several places on the Fort Worth, Houston and San Antonio Divisions and on the Texas Central Railroad, replacing pile trestles and steel work of lighter construction. Other bridges on the lines between Sedalia and Red River and Kansas City and Parsons, including the Missouri River bridge at Boonville, have been strengthened to permit the use of heavier engines which have recently been acquired, which will result in the handling of increased tonnage per train over that section of the line. The work of strengthening bridges in a similar manner between Denison and Houston is in progress, which will permit the use of these heavier engines over the main lines in Texas. Trestles have also been strengthened on the Texas Central Railroad, and on the Wichita Falls Lines between Frederick and Newcastle.

194 miles of embankment were widened and ditching was done on 156 miles of roadway.

50 miles of new ballasting was done and 242 miles of track re-ballasted. 1,966,657 cross ties and 945 sets of switch ties were used during the year. 32 miles of new fence were constructed and 362 miles of fence rebuilt. 51 miles of yard and industrial tracks were constructed.

New division terminals at Waco have been completed and put in operation.

A reduction of grade from one per cent to five-tenths of one per cent was made near West and Hillsboro, Texas, which permits an increase in the maximum tonnage handled by large engines southbound from 2500 to 3500 tons.

The double track work between Waco and Hewitt, Texas, 7.6 miles, which will facilitate train movement, has been completed since the close of the year.

A passenger station and office building at Parsons, Kansas, to replace the one destroyed by fire, is being constructed.

A new passenger station is under construction at Houston, Texas. That city has recently built a viaduct between the north and south sides of the town, passing over your Company's tracks at a point near the site of the new station.

New stations have also been constructed at Evansville, Franklin Junction, Humbolt, Crowder, Canadian, Sherman City, Cleveland, Nelagony, Winnsboro, Newsome, Burrows, Temple, Taylor, Hico and Albany, and many other betterments made.

Substantial improvements have been made in the water supply at different points, which are producing satisfactory operating results. Further improvements of this nature will be made as rapidly as the problems can be worked out.

Extensive changes are being made in the freight station at Saint Louis, which should result in a considerable saving in the cost of handling freight at that terminal.

At Dallas a new general office building has been acquired, the purchase involving the assumption by The Missouri, Kansas & Texas Railway Company of Texas of the payment of principal and interest of \$200,000 First Mortgage 5 1/4% bonds issued by the Katy Office Building Company.

The Union Terminal Company of Dallas, which was organized last year, has made very good progress in the acquisition of land and franchises for a passenger terminal, and plans are now being prepared for the building and track layout.

Work on the Kansas City Union Station has been delayed by strikes and other causes, but it should be ready for service during the coming year.

The growth of your Company's business during the past few years has been such that the terminal facilities at several of the more important points have been outgrown, and it will soon be necessary to provide increased facilities.

GENERAL REMARKS.

The Federal Congress enacted a law requiring the Interstate Commerce Commission to ascertain the value of the railroads of the United States. This is the most stupendous work of its kind ever undertaken by any Government, and it is of vital importance to the companies. It involves the solution of many complex problems, and agreement upon principles and elements of value about which there exists a remarkable diversity of opinion and confusion of thought. Your Company has appointed a Valuation Committee to prepare the necessary data and to co-operate with the Interstate Commerce Commission in arriving at the value of your Company's property. The cost of this work, both to the railroads and to

the Government, will necessarily be a considerable sum, and the work will probably be in progress for several years.

The United States Supreme Court decided adversely the suit of the Missouri railroads against that state seeking to restrain the operation of laws which established a maximum passenger rate of two cents a mile and fixed maximum freight rates on certain commodities. The reduced rates, accordingly, were made effective July 4, 1913.

It also became necessary for your Company and other companies operating in Oklahoma to enter into stipulations with the Attorney General of Oklahoma providing for dissolution of the temporary injunctions which had been secured against the enforcement of the two-cent passenger rate fixed by the constitution of that state, and the two-cent rate was made effective on July 3, 1913, pending final determination (including the matter of prior liability, if any) of the litigation on its merits.

Safety committees have been organized during the year under the direction of a commissioner of safety, for the purpose of educating the employees in the use of greater care in avoiding accidents.

Mr. Adrian H. Joline died on October 15, 1912. At the time of his death, he was Counsel for the Company at New York, and prior thereto had been Chairman of the Board and President of the Company.

At the annual meeting of the stockholders on April 10, 1913, Messrs. Frank H. Davis and Horace E. Andrews, of New York, were elected Directors to fill the vacancies caused by the resignations of Messrs. A. A. Allen and Alfred Waldron Smithers.

Mr. C. N. Whitehead, formerly Secretary and Treasurer, having been appointed by the President to act as his Assistant, the Directors at their annual meeting in April appointed Mr. Carl Remington as Secretary and Mr. Frank Johnson as Treasurer of the Company.

Statements and tables of accounts and operations are appended to this report.

Appreciative acknowledgment is hereby made of efficient services during the year of officers and employees.

By order of the Board of Directors.

FRANK TRUMBULL,  
Chairman.

C. E. SCHAFF,  
President.

MISSOURI, KANSAS & TEXAS LINES.  
PROFIT AND LOSS ACCOUNT.

Table 3.

Balance to Credit of Profit and Loss, June 30, 1912.....	\$4,729,386.16
<i>Additions:</i>	
Balance for Year Brought Forward from Income Account....	2,316,985.47
Adjustment of Value of Texas Central R. R. Co. Equipment as of November 30, 1912.....	232,401.20
Miscellaneous .....	8,492.41
Total .....	\$7,287,265.24
<i>Deductions:</i>	
Depreciation prior to July 1, 1907, on equipment destroyed...	108,324.85
Side tracks and other property abandoned.....	32,663.24
Discount and expenses of security issues.....	908,724.18
Uncollectible accounts charged off.....	27,625.29
<i>Dividends:</i>	
M. K. & T. Ry. Co. preferred stock 4%.....	\$520,000.00
Texas Central R. R. Co. preferred stock outstanding 5%.....	875.00
Texas Central R. R. Co. common stock outstanding 5%.....	135.00
Wichita Falls & Northwestern Ry. Co. common stock outstanding 6%.....	42.00
Southwestern Coal & Improvement Co. Sinking Fund transferred to "Appropriated Surplus".....	15,539.80
Texas Central R. R. Co. Profit and Loss balance June 30, 1910, taken up in Annual Report Profit and Loss Statement fiscal year 1911, now deducted.....	450,188.49
	<u>\$2,064,117.85</u>
Balance to credit of Profit and Loss, June 30, 1913.....	\$5,223,147.39

MISSOURI, KANSAS & TEXAS LINES.  
CONDENSED GENERAL BALANCE SHEET.  
JUNE 30, 1913.

Table 4.

ASSETS.				LIABILITIES.			
<i>Property Investment:</i>				<i>Common Stock, M. K. &amp; T. Ry. Co., held by the public .....</i>			
Cost of Road and Equipment .....	\$222,618,295.86				\$ 63,283,257.00		
Less Accrued Depreciation on existing Equipment (Credit) .....	1,048,906.84	\$221,569,389.02		Preferred Stock, M. K. & T. Ry. Co., held by the public .....	13,000,000.00		
Securities of Proprietary, Affiliated and Controlled Companies—Pledged ....	\$698,461.00			Common Stock, M. K. & T. Ry. Co., held by the Company .....	17,043.00		
Miscellaneous Investments.....	185,711.55	884,172.55	\$222,453,561.57	Stock, Subsidiary Companies (Page 24) .....	25,400.00	\$76,325,700.00	
<i>Securities Issued or Assumed Pledged:</i>				<i>Funded Debt:</i>			
Consolidated Mortgage Bonds (See Contra) .....		25,420,000.00		Bonds and Notes (Page 24) .....	140,769,990.97	\$217,095,690.97	
<i>Special Funds:</i>				<i>Consolidated Mortgage Bonds (see Contra) .....</i>			
Special Deposit account of Equipment Trust .....		1,062,558.45		Consolidated Mortgage Bonds in Treasury .....	184,000.00		
		<u>\$248,936,120.02</u>		General Mortgage Bonds in Sinking Fund .....	1,415,000.00		27,019,000.00
<i>Working Assets:</i>				<i>Working Liabilities:</i>			
Cash .....	\$1,502,733.02			*Loans and Bills Payable.....	\$ 1,516,385.55		
Loans and Bills Receivable	883,512.31			Traffic and Car Service Balances due from other Companies .....	938,608.04		
Traffic and Car Service Balances due from other Companies .....	817,809.46			Audited Vouchers Unpaid.....	2,717,335.40		
Net Balance due from Agents, Train Auditors and Conductors .....	260,855.41			Audited Wages Unpaid.....	1,213,847.77		
Miscellaneous Accounts Receivable .....	1,805,200.61			Miscellaneous Accounts Payable .....	273,210.13		
Material and Supplies.....	3,137,206.51			Matured Interest, Dividends and Rents Unpaid.....	640,399.19		
Other Working Assets.....	34,892.75	\$8,442,210.07		Matured Mortgage and Secured Debt Unpaid.....	17,000.00		
<i>Securities in Treasury—Unpledged:</i>				<i>Other Working Liabilities.....</i>			
Securities of Proprietary, Affiliated and Controlled Companies .....	\$417,420.30				45,297.76	\$ 7,362,083.84	
Securities Issued or Assumed .....	201,043.00			<i>Deferred Liabilities:</i>			
Marketable Securities .....	178,084.39	796,547.69		Unmatured Interest, Dividends and Rents.....	\$ 1,122,722.92		
<i>Accrued Income Not Due:</i>				<i>Taxes Accrued .....</i>			
Unmatured Interest, Dividends and Rents Receivable .....		15,202.30		Liability on account of Provident Funds .....	111,283.83		
<i>Deferred Assets:</i>				<i>Other Deferred Credit Items .....</i>			
Working Funds—Advanced Rents and Insurance paid in advance .....	\$ 60,566.53				82,161.72	1,706,935.01	9,069,018.85
Cash and Securities in Sinking and Redemption Funds .....	45,119.96			<i>Appropriated Surplus:</i>			
Cash and Securities in Provident Funds .....	1,460,000.88			Additions to Property since June 30, 1907, through Income .....	\$ 1,563,429.84		
Other Deferred Debit Items .....	111,283.83	2,001,373.92	11,255,333.98	Reserves Invested in Sinking and Redemption Funds..	221,166.95	\$ 1,784,596.79	
	324,402.72			<i>Profit and Loss Balance.....</i>			
					5,223,147.39		7,007,744.18
<b>Total .....</b>		<b>\$260,191,454.00</b>		<b>Total .....</b>			<b>\$260,191,454.00</b>

The Company is also guarantor of Kansas City Terminal Railway Company First Mortgage Bonds, due 1960 (jointly with eleven other Railway Companies).....\$30,094,000.00  
Of Joplin Union Depot Company First Mortgage Bonds, due 1940 (jointly with three other Railway Companies)..... 650,000.00  
Of Houston & Brazos Valley Railway First Mortgage Bonds, due 1937 .....

Of Beaumont & Great Northern Railroad First Mortgage Bonds, due 1939 .....

Of Galveston, Houston & Henderson R. R. Co. Note (jointly with International & Great Northern R. R. Co.)..... 133,000.00

\*\$800,000 paid to November 1, 1913.

# Railway Age Gazette

PUBLISHED EVERY FRIDAY AND DAILY EIGHT TIMES IN JUNE, BY THE  
SIMMONS-BOARDMAN PUBLISHING COMPANY,  
WOOLWORTH BUILDING, NEW YORK.

CHICAGO: Transportation Bldg. CLEVELAND: Citizens' Bldg.  
LONDON: Queen Anne's Chambers, Westminster.

E. A. SIMMONS, *President.*

L. B. SHERMAN, *Vice-President.* HENRY LEE, *Sec'y & Treas.*  
The address of the company is the address of the officers.

EDITORS.

SAMUEL O. DUNN, *Editor.*

ROY V. WRIGHT, <i>Managing Editor.</i>	H. H. SIMMONS	C. W. FOSS
W. E. HOOPER	H. F. LANE	F. W. KRAEGER
B. B. ADAMS	E. A. AVERILL	A. D. CLOUD
E. T. HOWSON	R. E. THAYER	GEORGE L. FOWLER
	A. C. LOUDON	

Subscriptions, including 52 regular weekly issues and special daily editions published from time to time in New York, or in places other than New York, payable in advance and postage free:

United States and Mexico.....	\$5.00
Canada .....	6.00
Foreign Countries (excepting daily editions).....	8.00
Single Copies.....	15 cents each

Engineering and Maintenance of Way Edition and four Maintenance of Way Convention Daily issues, North America, \$1.00; foreign, \$2.00.

Entered at the Post Office at New York, N. Y., as mail matter of the second class.

WE GUARANTEE, that of this issue 8,900 copies were printed; that of those 8,900 copies, 6,683 were mailed to regular paid subscribers and 248 were provided for counter and news companies' sales; that the total copies printed this year to date were 431,969—an average of 8,689 copies a week.

VOLUME 55. DECEMBER 12, 1913. NUMBER 24.

## CONTENTS

EDITORIAL:	
Editorial Notes .....	1107
To Make Discipline Just.....	1109
Grade Separation Laws.....	1109
The Discussion of Government Ownership.....	1110
"Safety First" Demands More Than Words.....	1111
New Books .....	1112
LETTERS TO THE EDITOR:	
Switch Indicators; by R. B. Abbott .....	1113
Efficiency in Large Yards; by E. T. Hopkins.....	1113
Is Standard Code Rule 20 Safe?.....	1114
MISCELLANEOUS:	
Railway Business Association .....	1115
Use of Interstate Commerce Commission Account Numbers for Correspondence Filing; by William S. Wollner.....	1117
Grade Separation Laws and Requirements.....	1118
Lignite Coal Testing Plant.....	1121
*Train Indicators at Charing Cross.....	1122
The Problem of Box Car Design.....	1123
Chicago Passenger Traffic.....	1125
*Convertible Stock and Box Car.....	1126
*Cab Window Ventilator .....	1128
*A. H. Smith.....	1129
Rate Advance Hearing .....	1130
Foreign Railway Notes.....	1114, 1117, 1121, 1122, 1128
GENERAL NEWS SECTION.....	1134

\*Illustrated.

BEFORE the full opinion of the Supreme Court in the Kansas City Southern case was available it seemed possible that notwithstanding the fact that the court had decided against the railroad, there might be, as there so often is in the Supreme Court's decisions, something within the case itself on which the court had based its decision without passing irrevocably on the general principles involved. The full opinion puts an end to any such hope if it had been entertained. The court in unmistakably clear language holds that the Interstate Commerce Commission is fully within its power when it orders railroad companies to charge to expenses the cost of property abandoned

when the cost of replacement is charged to property account. The court finds no merit in the railroad companies' contention that by permitting the abandonment of property vertically and refusing to permit it laterally, the commission is abusing the authority with which it is clothed. The court makes no attempt to minimize the great importance of the distinction between expenses of operation and additional investment in the property and makes it unquestionably clear that not only has the Interstate Commerce Commission full authority to prescribe the manner in which this distinction shall be made, but quite plainly sets the seal of its own approval on the method of dealing with abandoned property which the commission has adopted against the advice of many of the members of the Association of American Railway Accounting Officers.

THE tentative classification of revenues and expenses which the commission has recently sent to railroad companies for their discussion provides for depreciation for every class of material used in the maintenance of way and structures. The Supreme Court's decision in the Kansas City Southern case would appear to suggest that if the commission requires depreciation charges against roadway and track it will be following the Supreme Court's theories of sound accounting. The court says:

The contention of the appellant that property originally acquired because necessary in the construction of the road and afterwards abandoned only because rendered unnecessary by the improvement and development of the property should remain in the property account as a part of the stockholder's investment, will be found upon analysis to rest upon the unwarrantable assumption that all capital expenditures result in permanent accretions to the property of the company. This in effect ignores depreciation—an inevitable fact that no system of accounts can properly ignore. A more complete depreciation than that which is represented by a part of the original plant that, through destruction or obsolescence, has actually perished as useful property it would be difficult to imagine. . . . The real question is not how shall original cost be ascertained, but how shall subsequent depreciation in value be reckoned and accounted for.

There is one thing about the Kansas City Southern decision besides its definiteness that is to be welcomed. It is the clear pointing out that cost of progress is a burden on earnings, and it follows that earnings must be sufficient to pay for the cost of progress if we are to have progress.

"MY father chastised you with whips but I will chastise you with scorpions." This reply of young King Rehoboam to the people of Israel when he succeeded to the throne of Solomon will occur to railroad men when they read the changes in the parcel post rates. The railroads humbly asked for relief from the burden of carrying parcels for the post office department without compensation; and the reply of the government is an order raising the weight limit for packages from 20 lb. to 50 lb. when carried only in the first two zones, and from 11 lb. to 20 lb. for all other shipments. It is estimated that the business transferred from the express cars, where the railroad would receive pay for its service, to the mail cars, where it will receive no pay (until Congress sees fit to take action), will by this order be doubled. The order goes into effect January 1. The postmaster general agrees to ask Congress to adopt reasonable rates for the compensation of the railroads for carrying the mail; but Congress has a well-known habit of complying with such requests when it gets ready—usually after a delay of many months or years. After reading of the utter indifference of Congress to the appeals which have been made to it on behalf of the railways since the parcel post law was adopted, one is disposed to class the postmaster general's promises as trifles light as air. The latest outgiving from the government concerning mail pay is a statement charging that the rate paid for the use of postal cars is exorbitant; and on the strength of this a bill has been introduced in Congress to enable the government to own these cars. To congressmen who desire to see the government extend its activities in any and every

direction, this bill may seem reasonable; but it is difficult to see how any one else can so consider it. Mr. Peters has answered the charge of excessive pay, in a statement printed elsewhere in this paper. On short mail cars no rent at all is paid. But, whatever may be the equities, changing the ownership of the cars helps nothing; for all that the railways expect is a fair price for services and risks, and a fair interest on their investment.

**I**N spite of the fact that many men disagree with James E. Howard in his oft repeated conclusion that the cause of the recent frequent appearance of transverse fissures in rails is the overloading of the rails, he has railway men on the defensive when they attempt to prove him wrong. Mr. Howard follows up this advantage with an appeal for a thorough study of the stresses existing in track, based on actual tests rather than analytical deductions. Several thorough studies of this subject have been made from the theoretical standpoint and at present studies of this nature are the only ones possible as little accurate data of actual stresses have ever been collected. No other engineering structure is based so largely on experience without engineering design as is track construction. The primary reason for this is the presence of so many indeterminate factors, such as the character of subgrade, ballast, climatic influences, etc., which can be eliminated only by a very extensive series of experiments under a wide variety of conditions. At the same time, in view of the importance which the rail problem has assumed, a study of the stresses to which a rail is subjected would appear to possess equal importance with the study of the proper manufacture of rails which the American Railway Engineering Association is now investigating so thoroughly. It is fortunate therefore that the American Society of Civil Engineers and the American Railway Engineering Association are now arranging for the appointment of a joint committee of the two associations to undertake an exhaustive study of this kind and that sufficient funds are available for experimental work. It is to be hoped that the roads will extend all assistance possible to this committee in this important work.

**T**HE Massachusetts Public Service Commission requires the Boston & Maine to spend \$373,873 for interlocking signals, at a time when the company's net receipts are so low that its financial health is in a precarious condition. The decision was briefly noticed November 28. The absolute order applies to only one interlocking, but the "recommendation"—which, under the new law, is about the same as a command—applies to all places where the old ball signals are in use. This action of the commission appears to be equivalent to a disapproval of low speeds, for the old ball signals have been used with safety for many years—by limiting the speeds of all trains at places where these signals must be observed. Now, whether the road has the money or not, it must provide facilities for higher speeds. Interlocking switches and signals are the only right kind at junctions and crossings on first-class passenger railroads, and this paragraph is not written for the purpose of approving any but the right kind of signals; but it is a very crude and short-sighted policy on the part of a state to compel a road on the verge of financial failure to make costly improvements which are needed only because commissioners, having no financial responsibility, set up standards which have not been intelligently and conservatively compared with the actual conditions which have to be met. The Boston & Maine has spent hundreds of thousands of dollars for automatic block signals. It may have made a mistake in spending too much in that direction and too little for interlocking at junctions (though the automatics are for the prevention of collisions where, in a sense, the company is forced to run trains at good speed, while at junctions speeds are in nearly all cases reduced); but the decision, whether the policy was or was not mistaken, is a matter of administrative discretion with which the state should be very slow to interfere.

If a road lacks money, limitation of the speed of trains is one very rational means of avoiding large expenditures; but it is not a popular thing to approve slowness, and commissions are usually careful to avoid showing their hand in that direction. It is the duty of a state commission to call to account a railroad which does not give safe and adequate service; but to call for higher speeds at a score of junctions, at a time when the order necessitates the expenditure of large sums of money sorely needed for every-day necessities of life, is a perversion of authority.

**A**NNOUNCEMENT is made in our news columns of the plan for the reorganization of the Western Classification Committee, which is to go into effect on January 1, providing for a permanent committee of three members, including R. C. Fyfe, the present chairman, to be in continuous session at Chicago to hear petitions for classification changes, instead of holding semi-annual meetings at various places. This is in accord with the suggestions made by Commissioner Meyer in his report last year following the Interstate Commerce Commission's investigation of Western Classification No. 51, in which he strongly urged the necessity of affording wider publicity and fuller public hearings in connection with the future development of classification. He also recommended that proposed changes be submitted in smaller instalments, giving ample public notice of hearings to interested parties, and that representatives of the state commissions and of the Interstate Commerce Commission be invited to participate in all such hearings. The holding of continuous sessions will make it possible to consider groups of related subjects at one time, thereby giving all who are interested a much greater opportunity to be heard than under the present system, as well as insuring full publicity. Not only will the state commissions be invited to the public hearings, but the Interstate Commerce Commission has been asked to have a representative present at all sessions of the committee, both public and private. In fact this practice was followed at the last meeting of the committee at St. Louis. As one result of the change, it is to be feared that a large number of carefully prepared winter vacations will be seriously interfered with, for the meeting that was to have been held at Monterey, Cal. in January will be abandoned. Without belittling the importance of classification matters to a great many shippers, it may be said that it is pretty well understood in traffic circles that a large number of the subjects that have gone to make up the bulky dockets to be handled at these meetings have been brought up by industrial traffic men chiefly to convince their employers of the necessity of trips to the meetings at pleasant summer or winter resorts. This being the case it is not strange that the popularity of classification committees with the aforesaid employers has not been increased when their traffic men have returned without having accomplished the ostensible purposes of their long and expensive journeys. However, to a large majority of shippers a classification meeting is a far more serious matter than a junket, and doubtless many who should have been present have been kept away by the time and expense involved. To these a permanent committee located at Chicago will afford a very real convenience. Moreover, the work of classification can be performed far better by a small number of men giving their entire attention to the work than under the present system under which a large number give only a small part of their attention to it; and it would seem that far better results from all standpoints could be obtained by holding hearings at different times on different groups of commodities than by trying to hear everybody at once. Again, a standing committee on classification is far less likely to be influenced by the power of tonnage than a committee composed of railway traffic officers in regular service, and will be able to work out the various problems presented to them in a more scientific and satisfactory manner than has been possible in the past.

## TO MAKE DISCIPLINE JUST.

A RAILROAD superintendent, nowadays, with the up-to-date grievance committee constantly springing new arguments on him, is obliged to present every case of discipline to his superior so well fortified that it could run the gauntlet of the Supreme Court. That is to say, the general superintendent or general manager, when appealed to, will have presented to him by the committee such elaborate details and such forcible arguments against the superintendent's position, that only by equally elaborate details and still more forcible arguments can he prevent the committee from defeating him by mere weight. This looks like a very unfortunate situation for the superintendent. When the custom of appealing from dismissals and suspensions first began to be in vogue, many superintendents, accustomed to being final judges, sustained some very rude shocks. But there is another side to the case. Why should a superintendent ever impose discipline under any circumstances in which he cannot make out a strong case? Is it not a good restraint on him to be constantly reminded that he must dismiss or punish a man only for the soundest of reasons? Brotherhoods learn their methods from the lawyers and the courts; and in legal circles appeals, delays, re-arguments are the regular thing. No lawyer expects to win except after submitting to this test. The wisest judges, excepting the nine sitting in Washington, are constantly at the mercy of the litigant who has money enough to appeal. The railroad superintendent must in like manner submit to the applier. Railroad men whom the superintendent disciplines cannot employ counsel and go to the courts—as does a disciplined policeman in New York City—nor do they over-awe the court with their money as do rich criminals in New York and elsewhere; but they have the aid of brotherhood leaders, who have nothing else to do but supervise and strengthen the grievance committees, and this resource takes the place both of lawyer and of money.

Realizing the difficulty of making out a case strong enough for the Supreme Court when, perhaps, the main issue depends on such subtle things as a trainmaster's judgment about what kind of error an engineman will commit *the next time*, some superintendents have adopted the simple expedient of discussing every decision in important matters of discipline with a half dozen division officers. This is not a cure-all, nor does it do away with all delays. But it is an excellent thing for clearing the atmosphere. On the Erie road all of the important cases of discipline are brought up before a staff meeting which is held in the superintendent's office regularly every week. The superintendent is, of course, the sole author of the decision that is finally rendered, but he has the satisfaction of knowing that if his opinion agrees with the verdict of his subordinate officers he has their backing, while if he decides contrary to the views of a majority of them he is put on his guard so that he will care to fortify the case in his own mind very carefully before putting his signature to the decision.

And such a course not only strengthens the superintendent's position, it also makes his work easier, for the trainmasters, master mechanics and others who make up his staff find themselves feeling a more serious responsibility, and they are less likely to make recommendations which have to be revised or overruled. They present their cases to their superintendent in such shape that he can decide them more readily, while at the same time they are making better progress than before in fitting themselves to become superintendents, when their turn comes.

Grievances of superintendents against grievance committees would be much less heard of if every superintendent were to do everything in his power to go into every discussion, not only well armed but well stripped; not only with his good arguments all at his tongue's end, but with all the poor ones buried out of sight.

## GRADE SEPARATION LAWS.

THE abolition of grade crossings of railways and highways wherever possible is so important for the public safety and convenience that the legal provision for such work is a proper subject for legislative action. Nearly half of the states now have laws touching on the separation of grades, and the fact that 43 bills were introduced in 19 state legislatures and 13 laws were enacted in 12 of those bodies during the last legislative year shows that this matter is receiving plenty of attention from the law makers.

Some of the laws passed have been equitable and properly drawn to safeguard the interests of all concerned. Others indicate a desire on the part of their framers to force unwarranted expenditures on the railways. The two most important provisions of such laws are those fixing the manner of determining the necessity for proposed work and the apportionment of the cost. While in most cases either the Public Utilities Commissions or the courts are empowered to hear petitions from local authorities or citizens and to decide on the necessity of work involved, in some states the elimination of a fixed number of crossings each year is made mandatory regardless of the necessity for the work. Such a requirement tends rather to deter than encourage the rapid removal of grade crossings. Very few railways operate in only one state, and although the necessity for grade separation may be much more urgent at other points on the line, this work must be concentrated in states having mandatory provisions in their laws, for no railway company has unlimited amounts to spend for improvements which produce no revenue and in most cases have little effect on operating costs. A provision for a fair hearing as to the necessity for each piece of proposed work serves the interests of the public in general much better than a mandatory law, as it tends to concentrate expenditures at crossings where the need of grade separation is the greatest.

In fixing the proportions of the cost of grade separation work to be paid by the railway, city, town, county, state, street railway, public utility company, or other interested party, many of the laws indicate the prevailing tendency to burden the railways with all they can or will bear. Public opinion usually favors the assessing of all or practically all of the cost on the railway company. Even in Chicago, where the city's share—only the damages to abutting property—has been less than one per cent. of the cost of the work, which was paid entirely by the roads, there has been considerable agitation against the railways on this ground and one citizen's organization protested strongly against the payment by the city of a damage claim awarded in court to the owner of property affected by track elevation. While it is very difficult to determine exactly what division of cost is equitable, it is hard to see the equity of compelling the railway under all conditions to pay the entire cost of elevating or depressing its tracks, building new street approaches and subways or viaducts, as well as to pay all damages to abutting property, as is required by the state laws of New Hampshire and New Jersey. In fact, the commission in New Hampshire has in one case, on appeal of the railway, disregarded this law, and arranged an agreement by which the expense was divided 65 per cent. to the railway and 35 per cent. to the city.

In a decision on a petition for the separation of grades in Milwaukee the Wisconsin Railroad Commission concluded that "as both the railways and the city enjoy benefit from the existence of the tracks and will enjoy benefit from the separation of the grades as proposed, both should share in the expense." The division in this case assigned to the railways all work within their right of way lines except the grading and track work within the outside rails of electric lines and the changes to public utility mains. While this division forces the railways to bear a very large share of the total expense, which may or may not be equitable, it is rather



more fair to them than the divisions made in other cities where the most work has been done.

Although the actual benefits to be derived by the railways from the separation of grades, which are principally the saving in running time through cities and the decrease in personal injury claims, are not large, these items usually increase directly with the size of the city in which the work is done, and, on this basis, if the Milwaukee decision is equitable, the railways should not be apportioned as large a part of the cost in smaller cities. If a certain division of cost is found equitable for the separation of grades at a crossing where the highway was well established and carrying a heavy traffic before the railway was built, certainly the same apportionment would not be equitable at a crossing with a street which was opened over an existing railway line and the opening of which was due, perhaps, to a growth in the city which was a result of the transportation facilities afforded by the railway. The assessment to the railways of all or practically all of the cost of grade separation work can also be attacked on the basis of equity as between the communities served by a road. Since the cost of the work must be taken from earnings, all of the communities served by the road bear their share of the expense of an improvement which is of benefit only to the one community in which the work is done.

#### THE DISCUSSION OF GOVERNMENT OWNERSHIP.

THERE recently has been a notable revival of the discussion of government ownership of railways in this country. Two magazines appealing to classes that can hardly be called the most intelligent have been running series of articles advocating that policy. The chairman of one of the state railroad commissions recently has made an address and written letters trying to show that private ownership is costing the American government \$400,000,000 a year; and his utterances have called forth vigorous replies from President Ripley, of the Santa Fe. In Iowa, steps have been taken to start an organized movement for public ownership, and it is reported that one of the United States senators from that state will introduce a bill providing for it.

It may seem unfortunate for the railways that just when they are making the hardest fight in their history for fair regulation the question of the desirability of government ownership should be raised. The *Railway Age Gazette* believes that this is not unfortunate but fortunate for both them and the public, and that the railways should meet the issue squarely, and aggressively.

It has been inevitable, ever since the present policy of regulation was entered on, that in time, and in a relatively short time, it, and the controversies to which it was bound to give rise, would force the question of government ownership to the front. Every time, since the present policy of public control was entered on, that the railways have opposed any form of regulation, they have been warned by its advocates that unless they submitted the worse fate of government ownership would befall them. They probably will continue to be thus warned and threatened until the question of public ownership itself has been threshed out; and until then this form of threatening probably will tend to secure the adoption of forms of regulation which the roads oppose. For there are now many people who really believe that the public has much to gain, and the railway managers and owners everything to lose, by the adoption of public ownership; and who, therefore, will be prone, until the subject of public ownership has been more thoroughly discussed, to feel that so long as the public refrains from taking over the roads it will be justified in imposing on them almost any burdens or restrictions that it may please. Public ownership is, of course, the alternative to private ownership, subject to public regulation; and therefore discussion of public ownership and crystallization of public sentiment regarding it may be prerequisite to a fair and beneficial solution of the problem of public regulation. It is because we believe this to be the case that we regard it as

fortunate rather than unfortunate that there is occurring a marked revival of interest in the question of government ownership.

Assuming that the creation of an enduring public opinion in favor of the continuance of private ownership is prerequisite to the fair solution of the problem of public regulation, what may we think as to the practicability of creating such a public opinion? There are numerous serious difficulties in the way. First, the trend in our own country, and throughout the civilized world, is toward state socialism. The widespread mistrust of state action which was characteristic of the public opinion of the early part of the last century has given way to an equally widespread and unreasonable belief in the omniscience and omnipotence of the state. Secondly, many leading countries have adopted government ownership of railways; and it is often easier to persuade people to do what others have done than to persuade them to investigate the results of what others have done. Thirdly, there have been, and continue to be, many real, and still more seeming, abuses in the management of American railways. These things always promptly arise to confront anybody who undertakes to argue against public ownership; and, of course, the American public knows a great deal more about them, and feels much more keenly about them, than it does about the abuses and shortcomings in the management and operation of the state railways of other countries.

On the other hand, there are many conditions which strongly favor those who oppose government ownership.

First, while there has been in recent years a marked growth of socialistic sentiment in this country, the American people probably still believe more strongly in the benefits of private enterprise, and have less confidence in governmental paternalism, than the people of any other leading country. This is largely because of their own experience with governmental handling of business matters. They have seen their post office offices filled with political appointees and their post office department so managed that nobody can tell what the financial results of its operations are except that its receipts seldom equal its bare operating expenses. They have seen \$600,000,000 spent on improvements in inland waterways, in spite of which, because the money has been laid out "pork barrel" fashion, there are as yet no waterways in the country that carry a considerable traffic except the Great Lakes, which were provided by nature. They have seen public buildings, and even army and naval posts, located where they would best promote the interests of politicians, and almost regardless of where they would best promote the interests of the public. They have recently seen a Panama canal toll law passed which violates a national treaty in order to give a subsidy to a few ship owners, and for political reasons works an unfair discrimination against the people of the Middle West and in favor of those on the coasts. They have seen every imaginable form of extravagance, waste and even dishonesty in their city governments and in the management and operation of municipally-owned public utilities. These things, and many more like them, have made an impression on the minds of the American people which will not be readily effaced; and until it is effaced the argument that the government could and would manage the railways satisfactorily will have difficulty sinking in.

Second, with all their faults, the management and operation of the railways of the United States have been and are such, as compared with the way other public and private affairs have been handled in this country, and as compared with the way the railways of other countries have been managed, as to render it practicable to make an extremely strong case for private ownership and management. To the counts that there has been much unfair discrimination and that their accident record is bad our railways must plead guilty. But regulation has greatly reduced the discrimination; and the statistics of the railways of our own and other countries demonstrate that there is no connection between the form of ownership of railways and their safety. On all other counts in the indictment that their critics draw against them our railways probably can make a better defense than could any other railways in the world. Their capitalization per

mile can be shown to be much less than that of any other railways that can fairly be compared with them. They can be shown to pay the highest wages of any railways in the world, not only absolutely, but also in proportion to the cost of living in this country. It can be shown that, in spite of this, they make as low passenger rates as any other railways having a corresponding density of traffic, and the lowest freight rates in the world, except, perhaps, in Japan, where, of course, wages are extremely low; and that in proportion to wages and prices in the country where they are charged, their passenger rates are among the lowest, and their freight rates much the lowest, in the world. That they are able to do these things can be shown to be due to the fact that they have been developed and are operated with a skill and an economy that are the wonder, the admiration and the envy of railway managers throughout the world. The only country where the efficiency and economy with which American railways are operated is not conceded and appreciated is the United States! It can be shown that in no other country is the service rendered by the railways any better, or perhaps so good, considering the conditions under which it is rendered. It can be shown that while most state railways fail to earn the interest on the investment in them, leaving a deficit to be raised by taxation of the public, the railways of the United States return to the public in taxes almost 4 per cent. of their gross earnings, or about \$110,000,000 annually. Finally, and most important of all, it can be shown that in every democratic country where the public owns the railways the employees constantly use their political influence as voters to get concessions from the managements, and that the transfer to the government service of the 1,700,000 employees of the railways of this country, most of them organized into strong unions, probably would have the most baneful effects on politics, if, indeed, it would not work the overthrow of democratic government.

The case which can be made out in the court of reason for private ownership and management in this country is, on the whole, very much stronger than that which can be made out against it. The real danger is that the matter may not be settled in the court of reason, but in that of ignorance, sophistry and demagoguery, where so many questions of regulation are being settled. But the question of public ownership of railways is so extremely interesting and of such stupendous importance that it is probable that before it is finally acted on it will be given the most animated and thorough discussion and consideration; and the American public usually decides right on questions that have received such discussion and consideration.

#### "SAFETY FIRST" DEMANDS MORE THAN WORDS.

"SAFETY FIRST," as a watchword, if of any value, must be followed through thick and thin; success is not the only desideratum. If success eludes pursuit, all proper effort must nevertheless be continued. A reduction in the number of fatal or non-fatal accidents in a month or a year is an encouragement; but the duty of conserving lives and limbs remains, even if evidences of success are deferred. J. B. Fisher, superintendent of the New York division of the Pennsylvania, speaking to a recent meeting of a thousand of his employees in Jersey City (reported December 5, page 1086) said that in the past year the number of employees killed on that division had been larger than in the preceding year. Possibly an increase of business or in the number of men in service might afford some slight basis for an explanation of this increase; but Mr. Fisher rightly emphasized the point that percentages are not necessarily instructive; that actual causes are the thing to be studied. The aim of all should be to reduce the fatalities to zero. And he called the attention of trainmen to the fact that the increase was mostly in their class. Among the track repairmen—many of whom are ignorant, and often are classed as dull—the fatal accidents were fewer; but the records of trainmen and other classes more than balanced this decrease. And Mr. Fisher told the trainmen plainly that many of these cases of fatal carelessness ought to be classed as recklessness. The trainman feels too

"smart." In other words, the spirit which in the old days of the link-and-pin car coupler impelled men to risk their limbs, and often their lives, because they were too proud to couple with a stick instead of using their fingers, still prevails. There is, no doubt, a basis of truth for this view. Risky things can be done hundreds of times and be followed by no bad results; and to see the need of being constantly cautious so as not to be caught unawares the ten-hundredth time one must exercise his reasoning faculties. The safety-first movement must be availed of by everybody as a lesson in reasoning, if the expected good results are to be accomplished.

The Delaware, Lackawanna & Western also has published some figures which show that improvement in safety is not an easy thing to be produced by talking. The Lackawanna has accomplished encouraging results by its safety-first measures, as have other roads; but in August and September the number of employees killed was not smaller, but larger, than in the same two months of the preceding year.\* Commenting on this record, and to show how great a responsibility rests on the individual, howsoever much the company may try to do by means of precept or admonition, the claim department prints a statement of the causes of the 12 fatalities, which statement is copied below. This is a sobering record. Its 12 items illustrate 12 of the innumerable ways in which a small error can be the cause of a great horror.

1. Trainman went from his engine, which was on a siding, to the switch leading to the main track in order to let his train out after a through passenger train had passed. He fell asleep in such a position that his head was struck by the engine of the passenger train and he was killed. At time of his death this man had been on duty only 9 hours and 50 minutes and had been off duty over 13 hours before commencing the fatal trip.

2. Laborer had repaired door of a bad order car and started to walk around the east end of this car and through a space of only three feet between this car and the next. Some other cars were kicked down this track and he was squeezed so badly that he died. He had neglected to display a blue flag. There were no cars west of the bad order car where he could have safely crossed.

3. Trainman was hanging on side of coal car in a moving train cooling a hot box and was struck by a bridge which had proper clearance. He was killed.

4. Plumber stood upon a hot water pipe in a power house pit in order to be able to reach the floor. His weight broke the pipe and he was scalded to death.

5. Trackman was pulling weeds and did not notice an approaching train. He was struck and killed. Proper signals were given.

6. Employee in train service was dead-heading home and found that he had boarded the wrong train. In jumping off he fell and was killed.

7. Flagman dropped off eastbound train to go back with the flag. He stepped over on adjoining track and was struck and killed by a westbound train.

8. Flagman riding on front end of passenger train on which he was working, jumped off forward portion of the train as it was approaching terminal station, slipped on station platform, fell under train and was killed.

9. Section gang was filling in track and was warned about an approaching train. One member of the gang saw the train coming and yet stood so close to the track that he was struck and killed.

10. Bridge inspector was riding a speeder against the wind with his head down. He ran into a train and was killed. All warnings possible were given.

11. Trainman while turning up retainers on a moving train fell from it and was killed. No defects in equipment nor unusual speed of the train.

12. Track laborer tried to board a moving drill engine to get a ride to his work which was only 500 feet away. He slipped, was run over and killed.

To the thoughtful trainman, and indeed to any person employed around trains, each of these 12 lessons contains the material for a short chapter in itself. The list does not tell everything; it does not show how many of these men were young or inexperienced or insufficiently trained; or whether they were liquor drinkers or had habitually misused their rest hours. The question of possible contributory blame on the part of other employees is one which also is of interest in cases of fatal accidents. To know whether the accident occurred by day or night is instructive sometimes. Often it is claimed that a man has been overworked; in issuing a statement in print this point

\*Twelve in 1913 and five in 1912. For nine months to October 1 the number of employees killed was 32; in 1912 it was 31.

should be dealt with. Such claims, when unfounded should be exposed. Many employees who have been killed are known to have manifested reckless habits on previous occasions. One of the lessons of such a death may be that some one has neglected a plain duty in not removing the careless man from a position where life depended on habits of carefulness.

These obvious comments are mentioned here, not by way of criticism of the Lackawanna's list—the list may tell all that it would be useful to know concerning these causes—but as a reminder that to conduct train work, yard work or track-repair work with the highest attainable percentage of safety is a problem which includes many far-reaching problems.

#### NEW BOOKS.

*The Truth About the Railroads.* By Howard Elliott, chief executive officer of the New York, New Haven & Hartford, and of the New England Transportation Lines. Bound in boards, 260 pages. Price, \$1.25. Houghton Mifflin Company, Boston and New York.

This book is chiefly a collection of addresses which Mr. Elliott has made on various occasions within recent years. They deal with different phases of the railroad problem in the United States; and when brought together, as they are here, with the references to particular times and places eliminated, they constitute an interesting and pretty comprehensive discussion of the present situation and prospects of the railways, of their relations with their employees and the public, and of railway regulation.

One of the most marked characteristics of the book is the broad spirit of co-operation which it manifests; and another is its insistence on the rendering of justice on the sides both of the railways and the public as a prerequisite to true co-operation.

The chapter headings give a good idea of the work's contents. They are as follows: "Co-operation Between the Railway Owner, Employee and User"; "The Individual, the Corporation and the Government"; "The Conservation of Railway Service"; "Rate-Making and the Government"; "The Relation Between the Farmer and the Railroad"; "Agriculture, Banking and the Railroad"; "Transportation in New England"; "Public Opinion: Its Effect on Business."

Abstracts of most of these addresses have been published from time to time in the *Railway Age Gazette* and many other publications; in fact, few railway men's utterances have attracted so much attention within years as Mr. Elliott's; but to be fully appreciated the addresses should be read together and as a whole. They are bound to do the railways good wherever they are read; for Mr. Elliott has a gift for stating the railway case strongly and even aggressively, and at the same time so tactfully that he could hardly give offense even to those most hostile in their attitude toward the roads and their managements.

*Government Ownership of Railways.* By Samuel O. Dunn, Editor of the *Railway Age Gazette*; author of the "American Transportation Question." Bound in cloth, 400 pages. Price, \$1.50 net; by mail, \$1.62. D. Appleton & Co., New York and London.

The principal purposes of this book are stated by the author in the preface. "One is to give information as to the comparative results of private and public ownership and management of railways in various leading and typical countries. Its other, and main purpose is to direct serious consideration to the question of what would probably be the results of government ownership and management of railways in this country." The author long has believed that the policy of public regulation, and other conditions and developments would rapidly raise the question of the desirability of government ownership; and he has sought in this work to supply information that would throw light on that question.

In the first chapter he sets forth the reasons why the question is bound in course of time to come up for very serious consideration, and why it must be of peculiarly great importance in the United States. Two chapters on "Relations of Railways to the State," and one on "The Causes of Government Ownership," give the present situation in respect to the ownership of railways

throughout the world; the history, briefly, of the relations between the railways and the state in the important countries; and the reasons why government ownership has been adopted where it prevails.

The economic phases of the subject are then taken up. The conclusion reached in the chapter on "Cost of Capital" is that the government probably would not have, at least for some years to come, to pay, in the aggregate, as large a return to capital as do private corporations, but that this would be because, while private capitalists now assume all the risks of ownership and management, under public ownership the taxpaying public would assume them. This naturally raises the question as to whether, on the whole, government management would be more or less economical than private management—a question that is discussed at length in chapters on "Organization and Official Personnel," "Effects of Consolidation Under Government Ownership on Economy of Management," "Influence of Political and Labor Conditions on Economy of Management," and "Economy of Management of State and Private Railways." The conclusions reached, from a review of the evidence, statistical and otherwise, are, first, that private railways usually are operated more economically than state railways with which they may be fairly compared; second; that the state railways of undemocratic countries, of which Prussia is the best example, are operated more economically than those of more democratic countries, where political influences affect them more; and, third, that, under the political conditions existing in the United States, the railways of this country probably would be operated very much less economically under public than they are under private management.

Chapters dealing with the adequacy, the quality and the safety of service follow. The evidence is found not to support the view often urged by advocates of state ownership that in these respects state railways are superior to private. For example, it is shown that car shortages are quite as well known on the state railways of Prussia as on those of the United States, while they are practically unknown on the private railways of England; and that while the accident record of the private railways of the United States and Canada is bad, there are private railways, such as those of England and France, whose records for accidents are fully as good as that of the state railways of Prussia, and state railways, such as those of France, with accident records fully as bad as the worst records made by private railways.

Three chapters discuss rate making on state and private railways. The author concludes that state railways tend to make their passenger rates lower than private railways, while private railways tend to make their freight rates lower than state railways. He believes that unfair discrimination is more apt to be practiced by private railways, but that their managers show more enterprise and skill in so adjusting freight rates as to promote the development of industry and commerce.

The chapter on "Financial Results" shows that practically all state railways, except those of Prussia and Japan, fail to earn the interest on the investment in them, leaving a deficit to be paid by the taxpayers. That on "Condition of Labor" discusses the advantages and disadvantages of public ownership to the working class; but that on "Political Effects" deals especially with the probable political consequences of adoption of government ownership in the United States.

The last chapter sums up the various conclusions. The general conclusion arrived at is that while government ownership has worked well in some countries its adoption in the United States under existing conditions would be a step fraught with the gravest danger to both the economic and political well-being of the country.

The book contains a large amount of specific information regarding the history, organization, service, rates, earnings, expenses, financial results, condition of labor and so on on railways of numerous countries, and especially on those of Germany, the United Kingdom, Belgium, France, Italy, Austria-Hungary, Australasia, Canada and the United States.

## Letters to the Editor.

### SWITCH INDICATORS.

HARRISBURG, Pa., October 28, 1913.

TO THE EDITOR OF THE RAILWAY AGE GAZETTE:

I was very much interested in the article in your issue of October 24, referring to switch indicators. The Philadelphia & Reading has a fixed rule requiring the use of indicators at all switches in automatic signal territory, and while it is true that short-flagging, and at times the absence of flagging, may result from irregularities on the part of trainmen, it would seem that the net results show a credit due to the use of the indicators. Whether or not flagging rules are obeyed depends on the amount of inspection employed and the severity of the discipline imposed.

When indicators are not provided the way is opened for a very serious complication in the operation of a busy road. For instance, a train might receive a clear signal at the entrance of the first block in the rear of that in which there is another train standing on a siding and waiting to come out on the main track. The former train may run through that block at speed and approach the signal at the entrance to the block containing the siding on which the second train is standing and find that signal at clear. The second train, having no indication or warning of the approach of another train, is at liberty to go out on the main track under flag protection if it is not on the time of a superior train, and it might often happen that the switch would be thrown just before the following train reached the signal at the entrance of the block, throwing that signal to stop immediately in front of the train. Serious damage might result from the sudden application of air brakes to a heavy train moving perhaps 30 or 40 miles an hour, under these conditions.

For this reason the writer greatly prefers the use of indicators. They give due notice to the men in the siding and their efficiency in preventing wrecks and damage to equipment from the sudden application of brakes will be kept at a very high level by a proper inspection of the performance of trainmen and the employment of strict discipline for infractions.

R. B. ABBOTT,

Division Engineer, Philadelphia & Reading.

### EFFICIENCY IN LARGE YARDS.

HARTFORD, Conn., November 7, 1913.

TO THE EDITOR OF THE RAILWAY AGE GAZETTE:

Mr. Hale has asked for letters from men who actually handle the cars, as to just what they are doing to expedite movements. This would savor of blowing our own horn and looking for praise for doing our simple duty. So many factors enter into it that one knows hardly where to begin. The first principle to get fixed in one's mind is that a yard is not primarily intended to hold cars but is a place from which they are to be despatched. Usually the yardmaster is hampered by more work than he has facilities and force to handle expeditiously. This, of course, is no new truth. The superintendent, working on the basis of "cost per car handled" compares cost of one period with another and is anxious to see the figures decrease, believing that to be a test of the yard's efficiency.

The cost of per diem charges should be charged against a station, yard or division. This would tend to center attention on the release and forwarding of empty cars. We are systematically at certain dates given the "car situation" and urged to do everything possible to release and hurry home all foreign cars. I have often asked myself how many agents and yardmasters—and, indeed, I may say how many officers—have made a thorough effort to comply with this order. Is not the method wrong to a certain extent? Is not the personal, heart to heart talk by the trainmaster or superintendent more effective?

A thorough knowledge of the character and source of the

freight received in foreign cars, together with the same knowledge of shipments from each station on your own division should make possible a better use of foreign cars for homeward loads.

The average car distributor does not get out of his office, and he is liable to get into a rut. The old Cape Cod signs along the sandy roads, "Do not rut the road," would be a good thing in our business. Many trainmasters and superintendents are overburdened with other work of equally great importance and for that reason do not give much personal attention to the car question; but this explanation does not help us any. Some roads do have regular "car chasers" who even go away from home, to locate their own cars. Others have district inspectors (not division) reporting on demurrage matters to the car service department and co-operating with division officers. These men might to very great advantage go farther and report on cases of improper use of foreign cars—allowing cars to remain on hand after released; failure to report empty cars and also cases where local freight conductors are standing off the agent and not moving his empty cars.

I have been able to correct lax methods by taking a list of all cars at a station and checking it against the agent's car service book. This will disclose cases of empty cars not moved promptly, foreign cars loaded when home cars were available if properly placed, and loaded cars not promptly placed for unloading.

Another method used was to require agents to send me a carbon copy of their car service report. This showed up various things that would escape clerks in the office of the car service department, such as cars allowed to remain on hand after empty, and cases of company freight delayed, which would be released when a personal request was made on the proper department head. I have referred to way freight crews standing off the agent. This can be, and is almost, entirely overcome in territory where local runs are arranged so that the crews doing the local switching are returned to home terminal every day and thus do the work both ways. They then realize that the fewer cars at a station the easier their work will be, and are likely to prod the agent instead of waiting for him to prod them.

A short time ago, when in charge of a division terminal yard, I was making up solid trains for three Western terminals, when the division west of me suddenly shut down on taking empty cars. These trains contained a fair proportion of system cars, the balance being foreign meat, stock, box and coal cars. The situation did not clear up and I was soon obliged to re-switch to get out meat and stock cars.

We were then bordering on a blockade and obliged to work out of a bad situation as best we could. But we got a lesson, and after cleaning up, we set in force a new plan. At the first indication of a hold up on westbound cars I began to hold out all system cars and store them on outside tracks. This resulted in all foreign cars moving as fast as engines were available. There was no re-switching, and all system cars were ready in solid trains for local orders on divisions east of Buffalo. We were handling around 2,000 cars a day, probably half foreign. The saving may be imagined. So far as I know my superintendent never knew of it.

At another time, while the 20-day penalty agreement was in effect, an embargo was placed on hay destined to New York City. Almost before we knew it 800 cars had been backed up in our yard. The blockade was gradually worked down, a train or two a day, until only 135 cars remained. I then made a list of all foreign cars, together with the penalty date of each, and found 16 cars on that date already past the limit; four or five more would become penalty dates the next day and a week would see them all alike.

Without asking for instructions an extra shifter was put on and all the foreign cars made up into a train. When the situation was explained to the superintendent of freight transportation, room was made in New York City yards and the train of foreign cars was placed for delivery before daylight the next

morning. It should be noted that it was necessary to call on the chief despatcher and insist that he call the attention of the superintendent and get him to see that the train went forward without hindrance.

Somewhat a foreign car has come to have on me somewhat the effect that a red flag does on a certain domestic animal. This has resulted in many a car seeing home earlier than otherwise it would.

There are a few things in the nature of an experiment that I have long wished to see tried, to show the actual history of a car from the time it comes on the line until it leaves. Let some one take a list of a train just as it is to be delivered to a connecting road at any western terminal. Now go back to the record office and get the date and hour of receipt from connecting line, destination, when made up in train and hour and date of forwarding. Let the yardmaster explain delays, if any. Next have delays in transit explained by the chief despatcher; date and hour of arrival at destination with exact placing time. Get records of when released and when placed for loading; and in the reverse manner the same information back to the delivery of the car whence it came. A home route card giving train and station records from receipt of car to return would be valuable in any case.

The superintendent figures the efficiency of his division from moving a certain number of cars a day with a certain number of engines and with an eye on overtime and yard expense. Does he know that a drag received from the Union Pacific at 11 p. m. was switched before one received at 11 a. m. from the Rock Island; or that by paying an hour's overtime 50 or 75 cars would have been released to the Missouri Pacific?

He has nothing to show that the local freight conductor stood off the agent at Jonesville and left a bunch for "the other side of the run." He does not have any check on yard or station operation except the "average detention." It is impossible to devise any method that will do this automatically. However, if we charge the actual per diem charges to a terminal's expense as we do the cost of engines and men we shall then have an incentive to force delays to a minimum.

The yardmaster should be given a free hand to work out such plans as will bring this about. The yard as a machine or plant may show a larger cost per car, but a decreased cost of per diem. In this connection frequent visits of the superintendent and a frank spirit of co-operation have been known to work wonders in increasing the interest and initiative of men actually assigned to the task.

E. T. HOPKINS.

#### IS STANDARD CODE RULE 20 SAFE?

KANSAS CITY, November 13, 1913.

TO THE EDITOR OF THE RAILWAY AGE GAZETTE:

An extra west at Pekin, a blind siding, held an order that 2d No. 14 eastbound would run two hours late, A to Z.

No. 14 was due to leave A at 4:00 p. m.; No. 18 was due to leave A at 4:10 p. m. A train displaying green signals passed Pekin about 15 minutes late on No. 14's schedule, which the extra west mistook for 1st No. 14, but which in reality was 1st No. 18.

Following this train was 2d No. 18, which the men on the extra figured was regular No. 18. They concluded that 1st No. 14 and No. 18 had passed, and as they held two hours on 2d No. 14, they proceeded accordingly, but before going very far met another train on the main line, which proved to be 1st No. 14. First No. 14 was delayed at A and 1st and 2d No. 18 passed it at that point.

Who was to blame for the hazard?

This and a number of similar cases were related at Chicago during the superintendents' convention in August and the joint train rules committee of the American Association of Railroad Superintendents and the Train Dispatchers' Association of America took up the question with a view to making such recommendations as should seem adequate to overcome

the possibility of a hazard on account of the defect in the rule.

It was agreed that a distinction ought to be made between the last section of a convoy of sections and a single train fulfilling a schedule.

It was practically agreed at the joint committee meeting held in Chicago, August 20, 21 and 22, that first and intermediate sections ought to display yellow signals to denote a section following and that the last section should display green signals to denote schedule fulfilled. A single train fulfilling a schedule to display no signals.

But that is not the best plan. The committee was short of time and did not have an opportunity to give this important subject the consideration it deserves, and since that meeting it has been proposed, and will likely be recommended by the joint committee, that Rule 20 be modified to the extent that first and intermediate sections of trains display no signals and that green signals be displayed on the last section to denote schedule fulfilled, and that a single train fulfilling a schedule display yellow signals to denote schedule fulfilled.

Under this arrangement it will not be necessary to give the whistle blasts to call attention to flags or lights, as the inferior train will be obliged to be on the lookout for a signal which will permit it to proceed instead of looking for a signal which restricts its rights.

If we were to display yellow signals on first and intermediate sections, to denote a section following, and green on the last section, to denote schedule closed, and if we had three sections of No. 1 running late and on the time of No. 3, and the signals on 2d No. 1 became accidentally extinguished or carelessly forgotten, an inferior train might mistake that particular section of No. 1 for No. 3 and after 3rd No. 1 had passed, displaying green signals, proceed against No. 3.

Under the later proposal, where first and intermediate sections display no signals, and the last section displays green to indicate schedule fulfilled, and a single train fulfilling a schedule displays yellow, to denote schedule fulfilled by a single train, we are adhering to a principle that is absolutely safe, as well as sound and logical.

Would this arrangement have prevented the hazard referred to above? Let us see.

First No. 18 comes along displaying no signals. The absence of a signal is adverse to the waiting train. The extra might call it 1st No. 14; but next comes a train displaying green signals to denote a schedule fulfilled by the last section of a convoy of sections. The extra held an order that 2d No. 14 would run two hours late. The conclusion would then be forced that the first train was 1st No. 18. And the extra would not have pulled out in face of 1st No. 14.

If we were just forming a set of rules for the government of train movements, would not the logic of the recommendation tend to compel its adoption?

The suggested change will seem radical and, judging by past experience, will meet with opposition because of fear of danger in the change. But is there not more danger in retaining the present method?

This proposal is strictly in line with the slogan, "SAFETY FIRST." A signal accidentally extinguished or carelessly forgotten can result in no hazard; it merely ties the train up. It is a progressive step. Enginemen will no longer have to "whistle signals," and this will tend to abate the noise nuisance and give our "pernickity neighbors" less cause for complaint. It will lessen the occasions of disturbing the slumbers of passengers in sleeping cars.

P. T. D.

WOMEN RAILWAY WORKERS IN RUSSIA.—The Ministry of Roads and Communications has given permission for women who have obtained the certificate of railway runners at the Women's Polytechnic in St. Petersburg, to be employed in responsible posts on the state railways, with all the right of other state employees.

# RAILWAY BUSINESS ASSOCIATION.

Howard Elliott Frankly Goes to the Heart of the Railway Problem—Governor Cox Outlines Sane Governmental Attitude.

The Railway Business Association held its fifth annual meeting at the Waldorf-Astoria hotel, New York, on December 11, 1913. The business session was held in the morning and the annual dinner in the evening; George A. Post, president of the association, acting as toastmaster. Two addresses were made at the dinner, one by Howard Elliott, chairman of the board of directors of the New York, New Haven & Hartford, and the other by Governor James Cox, of Ohio. There were over 1,000 present.

## REPORT OF EXECUTIVE COMMITTEE.

The annual report of the general executive committee of the association is more or less optimistic, especially as regards the outcome of the rate hearings. Some of the more important parts of the report are as follows:

"Current experience," says the annual report of the general executive committee, just mailed to members, "tends to dispel the most serious ground for doubt of success for public regulation of privately owned railways. The fear has been that no tribunal of political origin would survive if it permitted an important general increase in transportation charges, because, it was predicted, the shipping public would always resist and when defeated would retaliate by attacks upon the commission. Instead of this we actually see organized shippers sending resolutions to the commission declaring not only that they will cheerfully accept an advance if found necessary, but that they will not be represented in opposition at the hearings.

"The public does not and should not relinquish its purpose of scrutinizing the practices of railway corporations and dealing with these where necessary. But it has been made manifest that when national prosperity requires a strengthening of railway revenue, public opinion will discountenance attempts to postpone action on the pretext that one or another specific theory of conduct must first be established and enforced. Railway managers are endeavoring as energetically as business men or men in public life to improve standards both of efficiency and of propriety.

"A number of members of the Interstate Commerce Commission and of state commissions after long service but still in vigorous health have recently retired. Not even an enlightened public opinion will insure the success of regulation unless men who have acquired experience and knowledge are retained. Security of tenure minimizes the waste of time and danger of mistakes involved in breaking in new commissioners, it gives the older commissioners an independence and serenity which promote efficiency and quality of work and it enables the appointing power to command the services of men who would not accept if they believed the position would be used as a political reward.

"Increased expenditures were compelled in 1913 by full crew laws passed in Arkansas, California, Missouri, Nevada, New Jersey, New York and Ohio; by safety appliance laws passed in California, Colorado, Florida, Kansas, Michigan, Missouri, Nevada, Ohio and Texas; by hours of labor laws passed in California, Missouri, Nevada, New York and Ohio, and by grade crossing laws passed in Arkansas, Minnesota, Missouri and New Jersey. The 40 state legislatures in session in 1913 enacted 343 laws specifically affecting steam railways as against 276 passed by 40 legislatures in 1911. The addition to operating expenses will aggregate very large sums. Only one state, New Hampshire, adopted a law permitting the railways an advance in freight rates prohibited under the previous statute.

"No systematic method has yet been put in effect for coordinating Congress, the legislature or the wage arbitration board which compels expenditures with the commission which regulates rates. We urge the need of mechanism for holding down the obligatory outlays to fit the railway pocketbook.

"Our association participated in the successful effort to have

Congress amend in 1913 the federal railway labor arbitration law. The changes made tend to assure the acceptance of arbitration by both sides and are fairer to both sides in that two neutral arbitrators instead of one must be convinced. Many believe that the danger of strikes should be guarded against by the further step of prohibiting, as in Canada, a strike pending an official investigation and publication of findings. The policy of urging this provision upon Congress and the state legislatures should be carefully considered."

## HOWARD ELLIOTT'S ADDRESS.

Mr. Elliott discussed the railway problem frankly and in a most searching manner. His address may be roughly summed up as follows:

National need of terminal and other railway facilities having been thoroughly impressed upon the public mind, shippers and editors generally convinced that larger net railway returns should be permitted, what are the reasons and perplexities which prevent the people from giving effect to a policy that will cure the trouble, making it unanimous? Even if there is only a vigorous minority opposed to such policy candid consideration of their objections is due them.

*Root Out Dishonesty.*—It is claimed that the management of some roads has not been honest—that insiders have profited when they should not. The morals of all kinds of business have improved year by year and things have been done in railroad and other business in the development of the country that were probably not right then—and that certainly are frowned upon now by law and public opinion. Such things ought never to have been done. Owners of railways should root out dishonesty if it exists, and if they will not, public authority will do it. But is there anything in the situation that warrants calling a halt on the development of a continent? Every time a clergyman, a doctor, a senator, or a cashier is punished, are we forthwith to abolish all clergymen, all doctors, all senators, and all cashiers, while we unfrock that particular clergyman, convict that particular doctor of malpractice, expel that particular senator, or jail that particular cashier?

*Prevent Over-Capitalization.*—It is said that some railways are over-capitalized. Whether they are or not, and certainly American roads have led the world in refraining from it, no more capitalization ought to be created than is necessary in order to serve the public. If too much was issued by some roads in the past, this is to be regretted, but no workable method has been suggested by which securities issued legally and bought in good faith can be taken from their owners without failures and receiverships that harm many more people than the owners of the securities. As for the future, every railway of importance runs through one or more states which regulate security issues. And apart from that, those responsible for railway management realize, as they never did before, the absolute necessity of sound business principles in issuing securities, law or no law. The present problem is not to restrict the issues of securities but to find people willing to buy them.

*Banking Experts Necessary.*—One hears that if securities were sold over the counter the bankers' commission would be saved. Perhaps some day, if confidence can be restored, part of such commissions might be saved, but a railroad must have financial experts, as well as engineering experts, and pay a fair price for services rendered. If the commissions can be saved they ought to be. But not even city, state and federal governments, whose credit is based on the taxing power, have been able at all times to float even moderately large popular loans without the aid of bankers; so it would seem to be to the interest of the people to be patient with a railway which has practically no control over the price of what it has to sell—transportation—and very little

control over the price of labor needed to produce that transportation.

*Dividends Sustain Credit.*—Others object because they say the new revenue would go to increase dividends. So some of it would and must. The dividend which a stockholder receives is not all that he would like or that his managers want to pay, but is an amount needed to induce him and others to buy more stock or bonds when an enlarged plant is necessary in order to meet the desires and absolute necessities of the public.

*Income from Economies.*—It is said that the increased income needed could be had by economies. It is true that economies have been introduced, and there is room for more of them. Railroad managers as a whole are pushing hard every day to improve men, methods and facilities. Many economies, however, can only be adopted by throwing away old appliances and buying new ones, which is the case in mills and factories as well as in railroads. And if the railroads have no money with which to get the new tools they must do the best they can with the old ones. No effort in this direction should be neglected, and no other industry is, or in the nature of things can be, so thoroughly organized, nation-wide, as the railways to co-operate in studying, experimenting and standardizing progress. But in view of the wonderful savings already accomplished, both major and minor, in the past few years, and the larger percentage of gross earnings absorbed by expenses and taxes, it is doubtful if the people should depend on such measures to offset the apparently irresistible rise in wages and in the price of materials, the higher cost of capital, and the demands for more elaborate facilities and luxurious service.

*Country Must Be Served.*—Are any of these obstacles sufficiently important to delay such revision of rate schedules as will meet this anomalous situation of increasing gross earnings, but declining net earnings, and still more rapidly declining net corporate income after payment of fixed charges?

The railway managers of the country want to know where to improve. They welcome just criticism based on real knowledge of all the facts. It is their purpose to profit by it. To serve the public adequately, on the other hand, is also their purpose, and it is their duty to seek diligently from the appropriate authorities the authority and help necessary, if the railway company is to do what the people want and must have if the country is to grow.

*New England Situation.*—For the New England lines that I represent, I ask the patient good-will of her people and of the nation while this peculiar and difficult problem is being solved, and I ask that all believe in our intention and desire to conform in good faith to the laws, state and national, when it is clear just what the laws are, and that there is no conflict between state and nation; and in our aim to serve the public interest to the extent of our ability—moral, mental, physical and financial. The tendency of rate regulation is toward a mileage basis, which must be modified to meet conditions such as exist in the United States—where many commodities must be moved long distances. This entails readjustment for many communities built up on well established rate relations. New England, owing to her geographical situation, would be crippled by the sudden and absolute application of a mileage basis.

*New England's Value to Nation.*—Those six states have one-fourteenth of the national population, but they have one-twelfth of the national wealth. They consume one-eighth of the materials of manufacture, and they have one-sixth of the bank deposits. New England appeals confidently to business men in other parts of the country to seek growth through the advantages they have rather than by attempting to force a readjustment which will involve serious consequences to New England and to the whole country, which benefits by New England's thrifty accumulation of capital, by her contributions to progress, by her very large purchases of the products of other regions, and by her great and persistent contribution to the national welfare in turning out trained men and women from her numerous educational institutions.

## GOVERNOR COX'S ADDRESS.

Governor Cox outlined the policies which he believes should be followed by the government in its treatment of the railways. An abstract of his address follows:

Something must be done with the railroad question. If you lay your finger on the pulse of the railroad organism you have unmistakable symptoms of the country's prosperity or adversity. When Ohio was stricken last spring with the great flood catastrophe we lay stunned and helpless until railroad communication was established. None will deny how important it is to conserve this utility, and by this is meant protection from unwise legislation and a guarantee of measurable safety to the individuals and institutions that have hazarded their capital.

Now, what is the condition of the railroads? Tonnage continues stupendous. Terminals in every city are insufficient. There is congestion. Service is beginning to show a lack of old-time regularity. Rolling stock is inadequate. The development of the country makes a call on the railroads for extensions and equipment which finds an enforced feeble response. They could advantageously to the public use hundreds of millions of dollars right now.

*Impaired Railway Credit.*—The railroads cannot borrow the money to provide for the situation. Short time notes have been given to meet current and emergency expenses, and if the banks were to demand payment we should be in the throes of a panic. Investors have been driven to other fields, notwithstanding no business is based on a more stable utility than that of the railroads. The amount of securities listed on the New York Stock Exchange by steam railroads in 1912 was the smallest in 10 years.

You hear in many quarters the statement that adverse legislation and the policy of regulation are the largest contributing factors. I do not subscribe to this view. Sane regulation will become the ultimate salvation of the business. One cannot resist the thought, when he surveys the abuses of over-capitalization, financial adventure and personal exploitation, that the mistake in regulation has been that it did not come soon enough. No one will seek to condone the practice of milking railroads in order that executive officers and directors might be illegally and immorally given vast fortunes through the artful and insidious method of contracting with themselves for construction work. No man in conscience will avow the propriety of a wild cat policy in the issuance of securities. No community in America will produce the man who will attempt to justify the practices which have shaken the confidence of the conservative thought of New England.

*Restore the Patient First.*—We might just as well recognize, however, that a puritanical severity is not going to do any good. The thing to do is to restore the patient and then prescribe and enforce a diet and behavior which will prevent recurrent illness. Each age brings its changes in accepted fundamentals of justice. Our fathers subscribed to many things in full conscience that are shocking to present-day ideals. We must therefore be consistent and recognize this as fundamentally just—that the transgression of yesterday cannot and must not be measured with the ethical yardstick of today. It is more creditable to adhere to this doctrine than to frame a policy of confiscating the holdings of present owners who are in no way to blame for the abuse of those from whom they bought.

You cannot buy land, lay tracks, build lines to mines, cities or agricultural centers, without an increased cost in investment. You can't sell the securities unless the public is assured of a return on the investment. Every phase of the fiscal situation of the railroads suggests that something be done not only to establish in the minds of the investing public some fixed idea of the inherent value of the railroads, but to frame a national policy, securely supported by an intelligent public opinion, for the conservation of the transportation utility. I introduce the suggestion that ultimate relief will never come until the Interstate Commerce Commission passes upon the issuance of securities. I spent a few days in Washington last week and heard everywhere the statement that the railroads would be given at once, without

a word, the desired raise in rate if the government were assured that the increased revenue would be properly applied. Ask the government to step in as a representative alike of the public, the railroads and the investor, issue securities of smaller denominations and in 10 years the great transportation lines will in fact belong to the people, and you will have public ownership rather than government ownership.

*Living Rates Necessary.*—Government, from the standpoint of morals and expediency, must permit the roads living rates. If it develops that while the gross receipts have increased, the net receipts are considerably diminished by the liberal policy of society, then relief ought to be granted, whether it be 1 per cent., 5 per cent, or 10 per cent. that is needed. There is nothing more harmful than the tendency to hold a fetish. There is no more offensive species of standpatism than to impose a rate one year and continue it without term.

Let us all dedicate ourselves to the solution of this great problem of transportation—recognizing that it concerns every community and every household. In the forum of public opinion every issue has been settled and ultimately settled right in this our glorious country. If progress means anything it is that prejudice cannot last and that fair dealing will endure.

## USE OF INTERSTATE COMMERCE COMMISSION ACCOUNT NUMBERS FOR CORRESPONDENCE FILING.

BY WILLIAM S. WOLLNER.

The use of Interstate Commerce Commission account numbers by all railroads has resulted in a larger number of employees becoming familiar with them than was the case when each road used its own system of accounts. Prior to July 1, 1907, if a man left the service of a road to accept a position with another, he found it necessary to learn an entirely new system of account numbers, and for that reason did not acquaint himself with them unless the proper performance of his duties required it. With the adoption of the uniform system of accounts by all roads, this is no longer true, and any person having to use accounts or statistics can well afford to memorize the account numbers, for as long as he remains in railroad service this knowledge will be of value to him.

It being practically necessary for most employees and officials to become familiar with the account numbers, it follows that these numbers should be used wherever possible in the office system. One place where they can be used with peculiar advantage is in the numbering of correspondence files, and this system of numbering proves of especial value where no file clerk is employed, as it enables any one who is familiar with the account numbers to find the file on any subject without consulting an index. Soon after the adoption of the uniform system of accounting, the writer of this article was called upon to install a filing system in the chief engineer's office of the Northwestern Pacific, and as this system has been in successful service for over six years he takes this means of recommending its use in similar installations.

In the use of this system each file subject is assigned a number containing four figures, the first two of which represent the subdivision of the road to which the file refers, and the last two the file subject. In the installation above referred to the road subdivisions were assigned the following numbers:

10—General	14—Wendling South
11—Willits North	15—Corte Madera—Green Brae
12—Shively South	16—River Landing—Monte Rio
13—Healdsburg North	17—Floodgate—Mill Creek

These subdivisions represent the different pieces of work undertaken and completed. As new work is started, it will be assigned numbers in consecutive order.

As above stated, the last two figures represent the file subjects and are the same as those furnished by the Interstate Commerce Commission for accounting purposes. Thus 01 represents

engineering; 02, right of way; 03, real estate; 04, grading; etc., etc. Combining the subdivision numbers with the subject numbers, we have:

File 1106 = Willits North, Bridges.
File 1307 = Healdsburg North, Ties.
File 1712 = Floodgate to Mill Creek, Track laying.
File 1008 = Rails, General.
Etc., etc., etc.

It is not expected that the account titles given by the Interstate Commerce Commission will fill all the requirements of subject tiles, and two means of expansion are provided: First, any subject may be subdivided into as many files as are needed by the adoption of a modification of the decimal system. This method is best illustrated by the subdivision of file 1106 so as to provide a separate file for each structure:

File 1106 = Willits North, Bridges General.
File 1106-1 = First Crossing.
File 1106-2 = Second Crossing.
File 1106-3 = Third Crossing.
Etc., etc., etc.

There are only 48 construction account numbers provided by the Interstate Commerce Commission, while 99 general subjects can be used for each subdivision of road under this filing system. The second method of expansion is, therefore, to use the additional 51 numbers for subjects that may be arbitrarily selected to fit the needs of the user.

This system may be adapted to the use of the maintenance of way department offices by using the first two figures to represent section numbers in conjunction with the numbers provided by the Interstate Commerce Commission for roadway accounting purposes. Thus, 9904 will represent rails on section 99; 1114, telegraph lines on section 11; etc., etc.

In the master mechanic's office this system of filing proves of more value than in any other place, for with it locomotive and car numbers are used in connection with the Interstate Commerce Commission account numbers, and a historical record is thereby provided for every piece of equipment on the division. At first these numbers seem large to handle, but one readily becomes accustomed to them and finds that their use is not difficult. File 130125 contains a complete record of repairs to engine 1301, while file 106233 contains the depreciation figures for coach 1062.

As this system of filing is capable of being used in every general and division office, it readily adapts itself to the consolidation of offices or divisions. No special instruction is necessary for its use, and the ease with which file numbers may be applied to correspondence as well as the fact that any person who is familiar with the account numbers may locate letters without reference to a file index, recommends its use in large as well as small offices. It is the experience of all who have to do with filing systems that the more complicated they are the less attention is given to the proper filing of correspondence; officials and others oftentimes retaining letters and reports in their desks rather than entrust them to a file that will not produce them when they are required. With the use of the system outlined herein there need be no uncertainty as to subject numbers nor necessity for awaiting the return of a file clerk or stenographer before a letter can be produced, and the confidence thus established should insure many of the documents that now repose in officials' and employees' desks going into the general files where they will be available for easy reference by all those who have use for them.

**STEEL TIES IN GERMANY.**—Steel ties are the only kind, other than wood, used by the various railroads of Germany. The Baden system is constructed almost entirely with steel ties. In Bavaria and Saxony, on the other hand, there are few or none. In the Prussia-Hesse system, which comprises about 60 per cent. of the entire mileage of the empire, about one-third of the ties are of steel. A more or less uniform type made of rolled steel, seems to have been agreed on as the best. In form it resembles a right-line arch, or, roughly, one-half an octagon. However, it is not equilateral, the upper or rail bearing side being about equal in length to one upright and one slanting side combined.



# GRADE SEPARATION LAWS AND REQUIREMENTS.

Abstract of 27 State Laws on This Subject and Discussion of  
Practice in Cities Where the Most Work Has Been Done.

[WITH AN INSET.]

A number of state legislatures have exercised their power to supervise the building of crossings of railways with highways at grade and to require the elimination of such grade crossings when public convenience or safety demands it, either by passing specific laws on these subjects or by delegating the power to deal with them to public service or railway commissions. The railways have realized the desirability of avoiding grade crossings as far as possible in new construction and of eliminating the existing crossings on lines which were built when cheap construction was essential and the necessity for separating grades was less urgent, and in general, they have not sought to prevent grade separation legislation. In some recent cases, however, where legislation on this subject has seemed unfair, railway managers who were directly interested have taken steps to influence such legislation along more reasonable lines.

## GENERAL PROVISIONS OF STATE LAWS.

The principle which has been most generally recognized in state laws providing for the elimination of grade crossings is the delegation of this power to the state commission or regulating body, leaving the decision as to the necessity for any given piece of work and the apportionment of cost of such work among the benefited parties largely, or wholly, to such commission. This principle has proved effective in practice, and the amount of work accomplished in states where it is in force has been very satisfactory both to the railways and the people. In view of the present trend in legislation, which seems to be toward the mandatory elimination of all crossings at the sole expense of the railways, a resume of the existing practice will be timely.

Some form of legislation has been passed in nineteen states looking to the gradual elimination of existing crossings of highways by railways at grade. These laws generally refer to the manner of determining the necessity for undertaking grade separation work and to the manner of apportioning its cost. One typical law provides that the state railway commission shall have entire charge of this work, hearing petitions either from the railway, municipality, street railway, county, highway commissioners, or other interested parties, or investigating upon its own motion the advisability of undertaking the necessary work to separate grades at a given crossing. In other cases, the law requires the elimination of a definite number of grade crossings each year, and in one state a special commission is created for each case to be considered.

As to the manner of apportioning the cost, the laws differ considerably. In Arizona, California, Michigan, North Carolina and Wisconsin, full power is delegated to the commission to apportion the cost according to the equities in each particular case. This principle recognizes the obvious fact that the relative advantage to the railway, municipality, street railway and public at large, may vary considerably in different cases. In other states the law denies the commission the exercise of this discretion, and fixes definite proportions to be followed in all cases. The states which specify the basis of division of costs are Connecticut, Massachusetts, New Hampshire, New Jersey, New York, Ohio, Vermont and Washington. Of these, New Hampshire and New Jersey are the only ones which impose the entire cost upon the railway under all conditions. In Connecticut the entire cost is paid by the railway, providing the petition to separate grades is made by the railway. In case the petition is made by the municipality, the latter may be assessed one-fourth of the expense at crossings of highways in existence before the railway was built and one-half at crossings of highways which were built across the railway.

In New York the principle of priority is also recognized by the provision that when a new railway is constructed across an existing highway above or below grade, the entire expense shall be borne by the railway, whenever a new street is constructed across an existing railway the railway company and the municipality shall divide the expense equally, and whenever a change is made in an existing crossing, the railway shall pay 50 per cent., the municipality 25 per cent., and the state 25 per cent. In Washington, the railway pays the entire cost when it crosses over or under an existing highway, and in all other cases it bears a portion of the cost, which is determined for each crossing according to the equities of the case. The other states in the above list specify a percentage of the cost which shall be paid by the railways under varying conditions, as given more fully in the abstract of laws herewith.

In Connecticut the railways are required to remove at least one grade crossing each year for every 50 miles of road operated within the state, and in Vermont, one for every 80 miles or fraction thereof exceeding 40. In some states, such as Illinois and Oklahoma, the railway commissions have proceeded to order and supervise the elimination of grade crossings under the general powers delegated to them for the regulation of the railways. In Oklahoma, such an order has been upheld on appeal to the Supreme Court. In some states, such as Virginia, Iowa and South Carolina, the law provides that the railway companies may enter into agreements with county authorities, municipalities, road commissioners, etc., for the elimination of grade crossings without delegating to any state body the power to force such action on the part of the railways. With a view to preventing the construction of grade crossings as far as possible, three states, Arizona, South Carolina and Washington, have passed laws requiring railway companies to secure permission from the state railway commission for each crossing that it is desired to establish at grade on a new line.

## ABSTRACT OF STATE LAWS.

The following abstract of state laws is taken in part from one compiled by the secretary of the Massachusetts Board of Railroad Commissioners, having been amplified in several instances by correspondence with the state commissions.

*Arizona.*—No grade crossings of a railroad and highway can be established without the permission of the corporation commission. The commission may alter or abolish any railroad, street railroad or highway crossing, or require the separation of grades, prescribing the proportions of the expense to be paid by the railway, the state, the municipality or other public authority interested.

*Connecticut.*—Local authorities or the directors of a railway company may petition the Public Utilities Commission in writing for the alteration of a highway grade crossing and after notice and hearing, the commission can determine what alterations should be made and by whom. If the petition is brought by the railway, the commission shall order the expense, including all damages, to be paid by the railway company. If the petition is brought by the municipality it may order that municipality to pay one-quarter of the expense if the highway affected was in existence when the railway was constructed across it at grade or the layout of the highway was changed for the benefit of the railway, and half of the expense if the highway has been constructed since the railroad which it crosses at grade, the railway paying the balance of the cost in both cases. Each railway in the state shall remove at least one grade crossing each year for every 50 miles of road operated in the state. If the company fails to observe this provision, the commission may order the removal of such crossings as it thinks should have been applied for by the railway. In the absence of an application, the Public Utilities Commission may, after a hearing on reasonable notice, order alterations in any grade crossing and may apportion the cost, provided that, in such cases, the state shall pay one-quarter of the expense, including damages, the remainder being charged to the railway, and, provided further, that not more than one crossing per year be so eliminated on any one railroad.

**California.**—The railroad commission has the exclusive power to alter or abolish a grade crossing and prescribe the proportions in which the expense of the alteration or separation shall be divided between the railroad, street railroad, state, county, municipality, or other public authority in interest.

**Indiana.**—The railroad commission is authorized to examine all grade crossings in the state, and collect complete information from railway companies, requiring surveys of such crossings if it is deemed expedient. Whenever it is concluded from the data at hand that the grades at any crossing should be separated, the commission has power to order the railway company to carry out the work. The commission prescribes the manner in which the separation shall be accomplished, the cost being borne crossing annually in each county, nor of more than one crossing for each one-quarter by the county and three-quarters by the railway. The commission can not order the separation of grades at more than one highway 200 miles or fraction thereof of the line of any railway in the state. The commission can not order any plan of grade separation which would require a grade on a steam railway track exceeding the established ruling grade on that operating division without the consent of the railway nor heavier than 2 per cent. on any street railway. Permission must be secured from the commission to establish a new grade crossing.

**Iowa.**—The state law gives cities with a population of 7,000 or over the power to require any railway company operating tracks across any public streets of the city to build and maintain viaducts providing the railroad commissioners pass on the necessity and the plans for such structures. No company can be required to build more than one such viaduct in any one year. Damages are paid by the city and by implication it appears that the entire cost of the viaduct must be paid by the railway. When the tracks of two or more railways are to be crossed by a viaduct, the city council, after a notice and hearing, determines the proportion of cost to be borne by the two companies. When a new railway desires to cross an established highway or when a new highway is to be built across an established railway, or when any citizen, any county board of supervisors or any railway company petitions for a separation of grades, the Railroad Commission, after notice and hearing, determines the necessity for such separation and the division of the expense. Any portion of the expense borne by a city, town, county, state, or other public body, must be considered as a trust held by the railway which cannot be considered as a part of the value of the company's property upon which it is entitled to receive a return.

**Kansas.**—The mayor and council of cities are given the power to require railways to build and maintain viaducts or subways to carry streets over or under tracks where it is deemed necessary for the convenience or safety of the public. The entire cost of the work including property damages must be borne by the railway.

**Maine.**—Petitions may be filed with the Railroad Commissioners by local authorities requesting separation of grades. The commissioners, after notice and hearing, shall determine what change is necessary and shall apportion the expense between the state, the town in which the crossing is located, and the railway, the state paying 25 per cent., the town 10 per cent. and the railway 65 per cent. When more than one railway is involved in such work the cost is divided between them according to the judgment of the commission. The amount to be paid by the state for such work in any one year is limited to \$15,000, which is paid from the annual railroad tax. When a street railway uses a crossing at which a separation of grades is made it can be assigned an equitable share of the expense.

**Maryland.**—There is no provision of law in Maryland for the elimination of grade crossings but for some time the commission has been gathering data on this subject with a view to recommending such legislation.

**Massachusetts.**—A special commission of three disinterested persons is appointed by the supreme court to consider petitions for alterations to, or eliminations of, grade crossings and to apportion the cost of such work between the railway, municipality and county, it being specified that 65 per cent. of the total cost be apportioned among the interested railroads, not more than 15 per cent. to any street railway which may be interested, and the remainder between the state and the municipality, the latter's share being not more than 10 per cent. A proposed amendment to this law provides that the amount apportioned to a municipality shall depend upon the benefit to the municipality and also upon its ability to pay, as it is held that in many cases 10 per cent. of the total cost is an excessive amount to apportion to a small municipality.

**Michigan.**—Under the state law, grade crossings can be eliminated by agreement between the railway company and a common council of the city, the board of supervisors of a county, or the township commissioner of highways; such agreement to provide for the division of expense and subsequent maintenance. In case of failure to reach an agreement, any of the interested parties may petition the railroad commission whose duty it is to investigate the necessity for separating grades at the crossing, determine the manner of performing the work if it is necessary, and apportion the cost.

**Minnesota.**—The commission is given authority to require the construction of an overhead bridge at least 18 ft. wide at crossings which, after proper hearings, have been found dangerous, provided the railway has been built or its grade lowered after the laying out of the highway and that the tracks are 7 ft. or more below the natural surface of the ground.

**Missouri.**—When a new railway is built across any road or street at a grade 10 ft. or more higher or lower than the surface of the highway, the company may be required to provide a suitable crossing for the highway either under or over the tracks.

**Nevada.**—The railroad commission has no power to order the elimination of grade crossings except by implication, and the commission's powers in this direction have never been defined.

**New Hampshire.**—A railway company may apply to the commission for authority to raise or lower a highway for the purpose of abolishing a grade crossing and a municipality may vote to require a railway company to abolish a crossing, the entire cost of the work in either case falling upon the railway. So far as is known, there is only one case in which a municipality has voted to require the abolition of a grade crossing, and in that case on appeal to the commission an agreement was made to divide the expense, 65 per cent. to the railway, 23 per cent. to the state, and 12 per cent. to the municipality.

**New Jersey.**—The Board of Public Utilities Commissioners may order a railway company to alter or eliminate a grade crossing according to plans approved by the commission. The entire expense, including damages, is paid by the railway unless a street railway uses the crossing, in which case the board may order the street railway to pay not more than 10 per cent. No municipality can construct a street across existing railway tracks and no railway can lay tracks across an existing street at grade without the permission of the Board of Railroad Commissioners.

**New York.**—When a new railway is built across an existing highway above or below grade, the expense of the crossing is paid entirely by the railway. When a new highway is built across an existing railway, the railway pays half and the municipality half of the expense. Whenever a change is made in an existing crossing on petition either of the municipality or railway, 50 per cent. of the cost of the work is paid by the railway, 25 per cent. by the municipality, and 25 per cent. by the state. In case the new highway built over a railway is a state highway, half of the cost is borne by the state, and when it is a county highway, half of the cost is borne jointly by the state, county and town, the other half being paid by the railway in both cases. The Public Service Commission may institute proceedings on its own motion in the absence of an application for alteration in an existing grade crossing, the changes ordered by the commission in any one year being so distributed among the railways and municipalities as to produce such equality of burden upon them as the circumstances will permit.

**North Carolina.**—The Corporation Commission has power to require the raising or lowering of any tracks or highway at a grade crossing and to designate who shall pay for the work.

**Ohio.**—The cost of separating grades, including the cost of property purchased and damages to abutting property, is borne 35 per cent. by the municipality and 65 per cent. by the railway. The council of a municipality may require the separation of grades by ordinance.

**Oklahoma.**—The Corporation Commission has exercised its general authority to order the construction of overhead crossings and these orders have been complied with by railway companies.

**Oregon.**—No grade crossing can be established without the consent of the Railroad Commission.

**Rhode Island.**—In case a railway refuses to eliminate grade crossings at the request of a municipality an appeal may be taken to the Public Utilities Commission, which has authority to order such work if it appears necessary. The proportion of the cost to be borne by the railway and municipality is decided by the court.

**South Carolina.**—The railways are prohibited from crossing another railway without consent in writing of the commissioners and from crossing highways so as to obstruct the same. The railway is empowered to raise or lower highways in order to secure separate grade crossings but it must first secure a decree from the county commissioners or other local authorities.

**Tennessee.**—The city of Memphis was empowered to require the grades of certain streets to be separated by the railways crossing them. It was specified that the railway companies bear all the expenses including the cost of the approaches and the damage to abutting property.

**Vermont.**—Petitions for elimination of grade crossings may be brought before the Public Service Commission by a municipality or a railway, the commission's order allotting to the state not more than 25 per cent. of the cost of the work, including damages; to the municipality not more than 10 per cent., and the remainder to the railway. If the highway affected has been built since the railroad which it crosses at grade, the commission may order the state to pay an amount not exceeding 25 per cent., the municipality 15 per cent. and the railway the remainder. Every railway operating more than 80 miles of single track road in the state must remove at least one grade crossing every year for each 80 miles or fraction thereof exceeding 40; one of these crossings to be that, which in the opinion of the commission, is among the most dangerous upon the company's lines.

**Virginia.**—When the change necessary to eliminate a grade crossing is to be made in the railway it shall be made and paid for by the railway company. When the change is to be made in the highway, it shall be made by the railway and the expense borne equally by the railway and the county or municipality. Whenever the work to be done cannot be agreed upon by the railway and local authorities, it shall be passed on by the state corporation commission.

**Washington.**—No railway can construct a grade crossing over another railway or highway without the authority of the commission to do so. When it is desired to cross a railway or highway at grade, a written petition must be presented to the commission setting forth the reasons why such crossing cannot be made either above or below grade and if,

after investigation, the commission finds it is not practicable to separate grades, a written order is granted giving the right to construct the grade crossing. A municipality, county or railway may petition the commission to alter an existing grade crossing, or in the absence of such a petition, the commission may proceed on its own motion. When a new railway is built over an existing highway, the entire expense of the crossing is paid by the railway. When a new highway is built across a railway or an existing grade crossing is eliminated, the cost is apportioned by the commission between the railway and the municipality or county affected, or if the highway is a state road, between the railway and the state according to the benefits accruing to the interested parties. When the commission orders the elimination of a grade crossing it may at its discretion pay an amount not exceeding 10 per cent. of the cost out of a stated appropriation for that purpose. In case two or more railways are involved in the elimination of a grade crossing, the apportionment between the railways shall be made by the commission if the companies are unable to reach an agreement themselves.

*Wisconsin.*—On petition of a municipality or railway or an action by the commission itself, the Railroad Commission of Wisconsin has authority to determine what alterations are necessary in a grade crossing and to fix the proportion of the cost to be paid by the interested parties.

#### GENERAL REQUIREMENTS OF CITIES.

Since the necessity for grade separation is most urgent in large cities, the most important work of this kind has been done in a comparatively small number of places. Railway managers are so frequently confronted with demands for improvements of this nature, some of which are not altogether reasonable, and in some cases it is such a difficult matter to show a municipality that its demands are unjust or unwise, that the following brief compendium of the practice in the cities in which the largest amounts of grade separation work have been carried out has been collected and tabulated to indicate the trend of practice in this work and the limits between which individual cases have varied.

The replies received from important cities show that the policy of handling such work under contract ordinances between the railway and the city is preferred in most cases. In 15 of the cities heard from such contract ordinances have been agreed to as compared with 8 which have passed mandatory ordinances. It is known, however, that in some of the cases reported as mandatory, acceptance clauses were provided which practically made them contract ordinances. In only five cases was the work done under the direct order of a state commission or court. The total cost of the work as given in the accompanying table is very likely to be misleading, and is presented only as a general indication of the amount of work undertaken in the different cities. In many cases the elimination of grade crossings has been carried on in connection with the building of new terminals, the relocation of line or other general improvements which greatly complicated the work and made the division of costs difficult. In addition to this it is impossible to be certain that the figures given are in all cases the total cost of the grade separation, as in some cases the work is still under way and only estimates can be made, and in other cases some portions of the cost borne by other interested parties may be omitted in the report. However, these figures of approximately \$140,000,000 for the work under way or completed, and more than \$25,000,000 for proposed work, show very clearly that grade separation has assumed very impressive proportions. The cost per crossing for those cities reporting costs averages \$197,000, although this figure is also somewhat inaccurate no doubt, for the reasons explained. The unit cost of eliminating grade crossings on the Pennsylvania Railroad in New Jersey was given by President Rea as \$73,000, but this difference is no doubt due to the fact that these crossings included many in small towns and rural districts where the topography favored the elimination and the cost was very low.

The division of costs among the interested parties shows a wide variation in practice. It is customary to make the division on a percentage basis, although in some cases, notably in Milwaukee, definite parts of the work have been assigned to the various parties on a basis of equity. In only two states represented in the table (Massachusetts and New York), has any portion of the cost been borne by the state. In the case of Toronto, the Dominion government assumed a small portion of

the cost. The largest percentage borne by the state is in Massachusetts where, in a number of instances, it has paid 31.5 per cent. of the cost. In 19 cases the cities have paid a part of the cost of the work, their share reaching 50 per cent. for portions of the work in New York and Cleveland. The railways have paid the entire cost in eight cities, and the minimum proportion borne by the railways in any city is 39 per cent. The street railways have participated in the cost in very few cases, except in paying for changes to their own lines necessitated by the improvements. Changes to water and sewer mains are paid for either by the railway, the city, or jointly by the two. In general, the changes to public utility companies mains and conduits are paid for by the corporation owning these utilities. In five cases the entire cost of such changes is charged to the total cost of the work and divided in the same proportion as the cost of construction. In two cases the cities assumed the entire cost of these changes. The damages to abutting property are paid by the city in four cases, by the railway in one case, and are charged to the cost of the work in six cases. In the remaining instances some other division between the railway and the city was agreed upon. It is usually conceded that the city can secure a more equitable adjustment of damage claims than the railways.

The clearances at subways and viaducts are very important, as they affect the plan of elimination to be adopted. In general, three methods of elimination are in use: the elevation of the streets without change of the track level; the elevation of the tracks without change of the street level; and the partial elevation or depression of the tracks, with a corresponding depression or elevation of the streets. The elevation of the tracks has a number of points in its favor which are well recognized by engineers, and which have been the cause of the adoption of this method either in its entirety or with some modifications for a large percentage of the work that has been undertaken. When the railway is carried over the street it is necessary to separate grades about 17 ft. to allow 14 ft. for head room and 3 ft. for depth of floor. When the railway is carried under the street the grades must be separated at least 25 ft. to allow 22 ft. for head room and 3 ft. for depth of floor. A clearance of 22 ft. is not always required, but even with a clearance as low as 16 ft. the required separation is 19 to 20 ft. The clearance shown in the table for subways with street railways varies from 13 ft. to 16 ft. 6 in. and for subways without street railways from 11 ft. to 14 ft. The clearance under viaducts ranges from 15 ft. 6 in. to 22 ft. 6 in. The latter clearance is required by the Canadian Railway Act, which provides that every bridge over a railway shall have a clearance of at least 7 ft. above the top of the highest freight car, such clearance never to be less than 22 ft. 6 in. above base of rail, except with the approval of the board. The roads entering Toronto made a strong appeal for a 19 ft. clearance under subways built in 1911 along the water front, but the commission denied the request and ordered the standard clearance to be provided.

The grades adopted for the railway and for the streets are very closely related to the clearance and type of structure. As shown in the table the street grades vary within wide limits. Three per cent. is the lowest grade which has been fixed as a maximum in any city; 3.5 to 4 per cent. being more usual. Many cities allow 5 to 7 per cent., however, and in cases where steeper grades exist in adjacent streets, much higher values have been allowed, the maximum reported being 12 per cent. Most cities adopt some maximum allowable change in street level, but like the grades, this value is extremely variable. In a number of cases it is specified as from 4 to 10 ft., although the maximum value runs up to 21 ft. The railway grades are, of course, much more important, as they may affect the rating for an entire engine district. In a number of cases grades exceeding 1 per cent. have been used, the maximum reported being 1.244 per cent.

#### VARIATION IN TYPES OF STRUCTURES.

The structures used for grade separation work are far from being standardized, and some railways that have had consider-

# REQUIREMENTS FOR GRADE

Street in subway.	Total.	Original.	Maximum	Street and railway grade crossings eliminated.	Number of openings through tracks per mile.	Abutting Damages.
	17	18	19	29	30	31
as original street in most cases.	66 ft.	.....	.....	780 to July, 1911.	Varies.	City pays damages recovered at law.
				13	Average 6	City assumes liability.
and roadway through subways.			5 ft	17	.....	Courts ruled no damages can be collected except for property taken.
as original street.			5 ft. 1 1/2	29	Not fixed.	By agreement and award of jury.
as original street.			4 ft. 8	14	Not fixed.	By agreement and award of jury.
one case 35 ft. subway on 40 ft. street.			3 ft. 1 1/2	4	Not fixed.	By agreement and award of jury.
as original street.			.....	9	.....	Railway paid damages caused by track changes. City paid damages caused by street changes.
as original street.			4 ft	14	No definite number.	By agreement and award of jury.
as original street.			.....	4	No definite number.	By agreement and award of jury.
			3 ft. 11	8	.....	Court settlement if parties cannot agree.
			.....	.....	.....	Charged to cost of work.
	66 ft.	66 ft.	.....	31	Not specified.	City pays.
ft. Min. 32 ft.		80 ft.	.....	4	11	Paid by railway.
			.....	2	.....	.....
			.....	68	.....	Divided equally, city and railway.
ft. 50 ft.—66 ft.		66 ft.	3 ft. 6	69	.....	One plan—City, 50 per cent.; ry., 50 per cent.
d. Sidewalks may be narrowed if traffic permits.			5 ft	10	No requirement.	One plan—City, 55 per cent.; ry., 45 per cent. Part of cost of work.
			.....	35	.....	Part of cost of work.
Original width of street not changed.			4 ft.	30	6—10	Part of cost of work.
Established curb and street lines.			.....	1	.....	Charged to work.
			.....	3	.....	By agreement.
of streets and walks.			.....	10	As many as needed	Charged to work.
50 ft.		50 ft.	.....	1	.....	By agreement.
			.....	15	.....	Some by city, some by railway.
ft. 66 ft.—76 ft.		66 ft.—76 ft.	.....	12	.....	City pays.
	60 ft.	66 ft.	.....	7	.....	.....







able experience in this line are still using a number of types, the choice between these types depending principally on local conditions. Steel structures have been used in by far the largest number for both subways and viaducts, although in many cases these have been provided with concrete decks or concrete fascia girders for ornamentation. Subways of reinforced concrete are quite generally used on a number of roads, and their slight additional initial cost is thought justifiable by many engineers. In some portions of the country stone arches have been used on account of the availability of that material. In almost all of the cities the full width of the sidewalk and roadway of the original street is required to be provided through a new subway or over a viaduct, especially on narrow streets. Some cities allow some contraction of the width on wide streets, or in cases where traffic does not seem to demand the full width. As the depth of a subway floor influences directly the amount of separation between the grades that is necessary, some subways with very shallow floors have been built, although except in cases where the depth of floor would affect the ruling grade, the deeper floor is generally used. The variation in depth shown in the table is from 1 ft. 6 in. to 5 ft. 1½ in. The tendency to provide all subways with ballasted decks to insure a solid, easy riding track and to reduce the noise, is shown by the fact that in 12 cities the subways have all been provided with ballasted decks, in three others part of them have been ballasted and in only four cases are they built without ballast. The prohibition of intermediate supports in subway spans has limited the design of the structures in a number of cities as this increase in span length makes impractical some types of structures, as for instance, reinforced concrete. In most of the cities where considerable work has been done the railways have been able to show the municipality that some intermediate supports would not seriously interfere with street traffic, however, and in only three cases shown in the table are intermediate supports entirely prohibited. In three other cities they are allowed only on the center line of the street; in eight on curb lines only, and in nine on curb lines and center of the street.

Very little has been done in the way of limiting the type of structures by ordinance or forcing the railways to provide ornamentation for such structures. There has been considerable agitation from some sources on account of the unsightly character of subways and viaducts, and railways have done much to improve the general appearance of these structures. It seems to be the general policy, however, to effect this improvement by adopting a design that will provide more pleasing lines than by adding features intended purely for ornamentation. In some concrete structures, surface treatment has been attempted with varying degrees of success, but on steel structures very little has been done with the exception of substituting a pleasing color of paint for the ordinary dark red or black. In New York and Philadelphia all structures must be approved by the Municipal Art Commission, and in Pittsburgh an art commission has recently been created which doubtless will influence design in that city in the future.

**ROLLING STOCK IN DENMARK.**—The rolling stock in Denmark at present is estimated at about 681 locomotives, 470 locomotive tenders, 1,628 passenger cars, 465 mail and baggage cars, 9,670 freight and livestock cars, and 47 wrecking cars, etc. There are 70 snow plows, and 8 steamships belonging to the railways, and 23 ferry steamers for the transportation of railway cars.

**AN AMERICAN PASSENGER CAR IN SWEDEN.**—The American passenger coach is unknown in Sweden. Some years ago a car builder in one of the shops of an important private railway, who had spent some time in American shops, attempted to introduce the American passenger coach. He built a car along American designs and installed imported plush-covered seats from the United States, but the people did not like the innovation, and the experiment has not been repeated.

**LIGNITE COAL TESTING PLANT.\***

A plant is about to be erected by Saskatchewan government at Estevan, Sask., for the purpose of developing and testing the lignite coal of that district. The plant will be in charge of S. M. Darling, a gentleman who has had a wide experience in this line. The following short account of what he has accomplished with North Dakota lignite is especially interesting to us in view of the fact that the lignites of Southern Saskatchewan and of North Dakota are of the same cretaceous character.

The chemical composition of these lignites precludes their being successfully briquetted in their natural condition. To market the lignite commercially in a large way it must be destructively distilled, carbonized or partially carbonized and the resulting gas, oil or tar, ammoniacal liquor and carbon residue utilized separately.

Analysis of a large number of samples of North Dakota lignite averaged on a dry basis: volatile matter 40.67, fixed carbon 53.33, ash (practically no sulphur) 6.00.

On carbonization, the products per ton of lignite in round numbers are:

Gas .....	10,000 cu. ft.
Oil or tar per ton .....	20 gals.
Ammoniacal liquor .....	35 gals.
Carbon residue .....	1,200 lbs.

**The Gas.** The yields of gas and oil depend largely upon the temperature and rate of carbonization. With a high temperature and quick carbonization the yield of gas will be high and of oil low; while with a lower temperature, and longer time in which to carbonize, there will be less gas and more oil.

The gas has a heating value of 450 B. t. u. per cubic foot. It contains a good percentage of illuminants, but has about 15 per cent. of carbon dioxide, which almost entirely destroys the illuminating power. This carbon dioxide can be removed by passing the gas through lime, but the process is too expensive for commercial application. The gas can be used as an illuminant by burning it in a mantle, but it is serviceable principally for fuel and power.

There is more gas in one ton of lignite than is required to carbonize the next ton. In practice only sufficient gas is removed to supply the requisite fuel to carry on the process. The remaining portion of the volatile is left to add heating value to the carbon residue. There is therefore no charge for fuel in the process.

**The Oil.** On distillation the oil yields:

Light oils, benzine, toluene, etc.....	11.5 per cent.
Carbolic, oils, some naphthaline.....	11.5 per cent.
Creosote oils .....	36.1 per cent.
Anthracene, some paraffine.....	18.4 per cent.
Pitch, hard .....	22.4 per cent.

This oil or its distillates can be put to many use—fuel oil, creosoting oil, leather preservative, waterproofing, pitch, etc. Upon exhaustive distillation it yields aniline dyes, carbolic acid, and in varying proportions all the other coal tar products.

**The Ammoniacal Liquor.** The liquor yields some acetate of lime, or if desired acetic acid, and about 15 lbs. of sulphate of ammonia per ton of lignite. There is a growing market for all of these materials, particularly the sulphate, as fertilizer.

**The Carbon.** The lignite crumbles on carbonization, which renders possible a continuous carbonizing process, obviating the laborious charging and drawing of retorts, as practiced in coal gas plants.

The cretaceous lignites retain largely their original woody structure, and hence do not break up so finely during carbonization. After removing by means of screens the small percentage of fines after carbonization, there remains practically lump charcoal of one-half to two inches in size. This can be used in gas producers, under boilers, and for domestic purposes. This lump charcoal is of about the same analysis as anthracite and has about the same heating value, but is not so dense in structure and therefore has somewhat more bulk per ton than the anthracite.

\*Reprinted from the *Public Service Monthly*, Regina, Saskatchewan.



The fines have to be briquetted, or still further pulverized and burned as powdered fuel\*, a practice which is rapidly gaining favor.

Actual briquetting and burning tests of this fuel in car load lots demonstrate that satisfactory briquettes can be made with not to exceed 2 per cent. of starch and 6 per cent. of coal tar or lignite pitch as binder.

The briquettes burn with a short flame, no odor, no smoke and no clinker. They can be used wherever anthracite or bituminous coal is burned. They retain their structure in the fire until completely burned. They do not disintegrate or lose value in the weather, and can therefore be shipped any distance without loss.

The lignite coke is an ideal gas producer fuel. A satisfactory gas producer generating gas for power purposes from fuels containing a large amount of volatile, as does the raw lignite, is not available. But with the volatile removed, this lignite coke, transformed into producer gas and used in a gas engine to generate electricity, effects an enormous saving over the present method of producing electricity by means of boilers and steam engines. The gas producer requires only about one-fourth the fuel necessary with boiler and engine to produce an equal amount of horse power. This producer gas also is an exceptionally good fuel for burning brick, tile, etc.

To defray the cost of carbonizing and briquetting there is the revenue from the by-products and it is known that the income from this source will at least meet that charge. But aside from this, there is to be derived from this carbonizing process the enormous benefit afforded by the possibility of mining and shipping lignite the year round, because the product is put into a condition which prevents deterioration no matter how long the fuel is stored or how far it is shipped.

### TRAIN INDICATORS AT CHARING CROSS.

In the Charing Cross Terminus of the South Eastern & Chatham Railway, in London, the interior arrangements in the waiting rooms, ticket offices, etc., have lately been entirely rebuilt.

\*Mr. Darling expects to get a railway fuel from this lignite dust.

and in connection with the improvements there has been put up a new train indicator, a photographic reproduction of which is shown herewith. The indicator is immediately above the gate leading from the ticket offices to the train shed, in the most favorable position to be seen by all outgoing passengers.

The indicator is similar to that at the Euston station of the London & North Western, heretofore described in these columns, and, apparently, is an improvement on that, in that a larger number of trains can be shown at one time.

The peculiarity of this indicator is that, with the minimum of manipulation, all of the trains of immediate interest can be shown, in large letters, while at the same time the legends for the trains not wanted are entirely concealed. This is accomplished by putting the inscriptions on cloth curtains, carried on horizontal rollers, one at the top and one at the bottom.

In the view here shown the indicator displays the announcements of all outgoing trains from 3:38 p. m. to 6:05 p. m., and the destinations of each train are set forth at considerable length. The two curtains shown are exact duplicates of each other; but that at the right hand has been rolled up one step farther than the other. Thus 17 trains are shown without extending the placard to the inconvenient height that would be necessary for that number if all the trains were to be listed in a single vertical column. After the departure of the 4:47 train both curtains can be rolled up one step; then the left hand will show the trains which now appear at the right, and the right hand curtain will show the next 8 or 9 trains. The figures at the right on the curtain, indicate the platform numbers.

A GERMAN BRIDGE-TESTING CAR.—A few years ago the matter of providing better facilities for the purpose of testing bridges was taken in hand by the Breslau Railway Directorate, and the result is seen in the introduction of a special bridge-testing car. An old fourth-class coach was converted into a specially equipped car, the interior being divided into two compartments, the larger of which contains the appliances and instruments used in making the tests, while the smaller one serves as an office, in which the results of the tests are worked out.



Bulletin of Departing Trains, Charing Cross Station, London—South Eastern & Chatham Railway.

# THE PROBLEM OF BOX CAR DESIGN.

## Effect of Dead Weight on Net Earnings; Standard Rolled Sections Versus Pressed Shapes for Steel Body Framing.

At the meeting of the Railway Session of the American Society of Mechanical Engineers, December 3, George W. Rink, mechanical engineer, Central Railroad of New Jersey, presented a paper on Steel Underframe Box Cars, an extract from which was published in the *Railway Age Gazette*, December 5, 1913, page 1081. In the absence of R. W. Burnett, general master car builder of the Canadian Pacific, the paper on Steel Frame Box Cars, which was abstracted in the *Railway Age Gazette*, December 5, 1913, page 1075, was read by H. H. Vaughan, assistant to vice-president, Canadian Pacific. The papers were discussed by H. H. Vaughan, Canadian Pacific; B. D. Lockwood, chief engineer, Pressed Steel Car Company; W. F. Kiesel, Jr., assistant mechanical engineer, Pennsylvania Railroad; O. C. Cromwell, mechanical engineer, Baltimore & Ohio; E. G. Chenoweth, mechanical engineer, Rock Island Lines; W. S. Atwood, chief engineer, Canadian Car & Foundry Company, and C. A. Seley, American Flexible Bolt Company. Extracts from the discussion follow:

### CONSIDER AVERAGE SERVICE IN DESIGNING CARS.

H. H. Vaughan.—I feel that Mr. Burnett's paper has, unintentionally, to a large extent referred to what Mr. Rink has said about the standard car. Personally I feel that Mr. Burnett's position, that with the structural steel car we have to all intents and purposes a car that is standard as far as any car can be standard, is a sound one. I do not believe that we are ever going to adopt one standard type of car or one standard design of car and build it indefinitely. There are sure to be improvements and alterations that the different roads think it desirable to make, and if we had a standard car tomorrow the next order that was let would have a few changes from it. If we use standard material that can be obtained without difficulty, and keep to certain standards on the parts that both Mr. Rink and Mr. Burnett have mentioned, I think that we are going as far as we can go in the direction of a standard car.

I quite agree that the draft castings, arch bars, bolsters and some of the other parts should be standardized to a greater extent than at present. It does seem absurd that the slight variations made in these parts should necessitate their being obtained from the car owners, when repairs are to be made on foreign lines, and that serious delays should ensue on account of these parts not being available.

We have been a good deal criticized on account of certain features in the design of the Canadian Pacific car, such features as I think Mr. Rink refers to when he says there was not very good engineering carried out in the design of the steel underframe. Some of the features of our underframe design were not altogether a question of engineering, but largely governed by a feeling I had that if you make a thing plenty strong enough you never lighten it, but that if you make a new design a little fine and then strengthen it at the weak points, you will finish up with a considerably lighter design than if you started out with some arbitrary figures and made everything plenty strong enough to start with.

In designing a car what must be considered is the service in which it is generally going to run, not the service in which it may run. We estimated that 60 per cent. to 75 per cent. of the service to which the box cars are put, both in Canada and in the United States, is service in which the old type of underframe will stand up perfectly satisfactorily. I feel that that assumption is justified by the results we have had. If there was any decided weakness in this type of car we would certainly have found it out in five years. The fact that we have had 14 or 15 cars destroyed on foreign lines indicates that, while the construction may not be as strong as would be desirable for some service, it is strong enough for the average service in which the cars are used. I do

not believe today that it is a good commercial proposition to put weight in a car for occasional service.

The omission of the end braces and the corner braces has been discussed. The center sills and the side sills have ample strength to hold up the corners of the cars under general conditions, and the saving of 500 lbs. weight there, and 500 lbs. in the cover plate, and a few hundred pounds here and there, is what has made the car as light as it is.

Attention should be drawn to the effect of reduced weight on net earnings, and not on the cost per ton mile. The Canadian Pacific figures for 1913 show that we carried 22.34 tons per loaded car mile, and our light car mileage was 28.5 per cent. of the loaded car mileage. That gives an average load of 16.8 tons per car mile total. I have not the average car weight, but I do not think we are far off in taking it to be 18 tons; the average weight of the car loaded was then 34.8 tons. I do not believe that figure is out of the way for a large number of roads in this country handling general traffic. We have a large amount of grain, and while we do not have much coal our average load is fairly good.

Supposing the car weighed one ton more. Without any question as to whether we would always change our train rating, the weight of the car loaded would be 35.8 tons instead of 34.8; in other words, there would be an increase in the ton mileage of 2.85 per cent. Or suppose we were operating on a ratio of 70 per cent., under this changed condition of weight we would be operating on a ratio of 72 per cent. Our net tons would fall from 30 per cent. to 28 per cent., which is a difference of 6 per cent.; in other words, while we have only changed 2 per cent. in our cost of transportation, we have changed about 6 per cent. in our net earnings, and net earnings are what we are after. It does not take very much of a change in transportation matters to make quite a change in net earnings. It takes less than it does to make a change in gross earnings. Even supposing that one-half the time the weight of the car makes no difference, it depends on how tonnage is handled; on the Canadian Pacific, on which a large percentage of the traffic is on grades over .6 per cent., tonnage is what we are after. If we are within a certain number of tons of the right load we take it, and if it is less than that we put on another car. Taking only half, the handling of a ton makes a difference of one per cent. in the expenses and 1½ per cent. in the net earnings. Taking the size of the car, and only taking one-half of the actual difference in weight, we find that it amounts to about \$12 per ton per year. That is only assuming that one-half the difference in weight makes any difference. We can do a good deal on a lot of cars with \$12 per ton per year.

The question of weight is something which must be looked after carefully in car design; we must not give all our attention to designing a car that is cheap to keep up and which will not need repairs, but try to design a car that is most economical for the railroad company in handling its traffic. It may cost \$5 or \$10 a car more per year to keep up, but it will save two or three times that in the weight that is being hauled about uselessly.

In reference to vertical or horizontal sheathing, Mr. Burnett stated that there were a number of cars which were quite open. We have had a lot of cars which have shrunk to an extent to cause us a great deal of anxiety, but we have had singularly few cases of damage claims on account of it. The planks are all ship-lapped, and when looking at a car it would almost seem possible to see through the openings. But it is not difficult to tighten them, and the only reason we have not done so is because we have not had sufficient complaints to justify our taking the cars out of service and doing the work. The vertical sheathing would be, possibly, a preferable arrangement if it could be accompanied by an economical and convenient design of side framing. The

truss form of side framing naturally lends itself to horizontal sheathing. We are using very extensively the same style of end for repairs of all-wood box cars that we use on the steel frame car, simply putting in two Z-bars, reinforcing the ordinary end post, and putting the  $\frac{3}{4}$  in. lining outside.

#### SPECIFICATION OF MINIMUM STRESSES.

B. D. Lockwood, chief engineer of the Pressed Steel Car Company, stated that he believed the railways should specify the minimum stresses allowable in box car frames in order that builders may have something definite to work to.

#### RATIO OF STRESS TO STRAIN.

W. F. Kiesel, Jr.—There is one feature in Mr. Rink's calculations for end strength to which he has not especially called attention, and that is the ratio of stress to strain under end shock. The important point to consider is that at the bolster. This ratio in the cars enumerated varies between .033 and .118. The high figures are due to the great distance between the center line of the drawbar and the neutral axis of the sills. The area of the center sills at the bolster varies from 19.08 to 36.18, and the average is 24.75. Without using any additional material in the center sills the ratio of stress to strain can readily be reduced in many of these cars to the advantage of the strength of the car.

The authors of both papers seem to favor the Z-bar posts and braces because they are made of rolled material, and, as stated by them, can be readily obtained. This does not seem a good argument, as it is well known that standard sections of rolled material cannot always be obtained on short notice; in fact, within the past year the steel mills have quite frequently reported that certain angles, etc., could not be furnished under three or six months, as there was no stock on hand and they did not expect to put in the rolls for that length of time. Advocates of pressed steel for this purpose assert that pressed steel posts and braces are lighter per unit of strength, because they can be formed to the required shape; that they can be formed with sufficient surface at the ends for the number of rivets required to develop their full strength, while Z-bars and other rolled forms require gusset plates for this purpose; that they are not likely to be damaged by pushpoles, and if damaged in wrecks, can be readily straightened and restored to approximate shape; and that when absolutely necessary to replace them they can readily be obtained from the car owner or builder, without waiting for any special rolling of material.

All of the 14 cars enumerated by Mr. Rink have so-called box-girder center sills, and the majority of them have a minimum section of about 24 sq. in. With this section area a ratio of stress to strain of .06 can be obtained, provided proper adjustment is made for the relative location of the neutral axis of the center sills and the center line of the draft gear. It would, therefore, seem that the present designs of box cars corroborate the recommendations of the Committee of Car Construction of the Master Car Builders' Association and that those recommendations are reasonable and conservative. A thorough knowledge of cars by the motive power officials of railroad companies will, I hope, lead them to ultimately endorse the M. C. B. recommendations.

#### DIAGONAL BRACES IN END FRAMING.

O. C. Cromwell.—Side and end posts and braces, corner posts and door posts, should be brought down to a standard; they are now very nearly this.

The height of the floor above the rail is an important point, and there should be no good reason why we should have a variation  $6\frac{3}{4}$  in. in this height. This also affects the height of the truck, as if it is desired to work toward standard and interchangeable truck parts, the height of the truck is an important one to bear in mind.

I observe that no diagonal braces are used in the end framing of the Canadian Pacific steel frame car, such as are generally used in the end of a wooden frame car. These braces tend to keep the end framing of the car square. While their omission would probably not be apparent for the early life of the car,

should we not expect to find, as the car ages, a loosening of the riveted joints uniting the posts with the plates and underframe? While the car is new, the end sheathing will serve to keep the framing straight, but will we not in time experience loosening of these end boards through shrinkage?

We know that on gondola cars the side planks decay under the side stakes and under the corner bands. May we not, as the cars become older, experience a similar action of the lumber in this character of car? Would not this in turn lead to the loosening of the framing?

The Baltimore & Ohio built, in 1862, some iron box cars. These cars had wooden underframes, but the body and roof were made of iron plates. The cars proved unsatisfactory because in the summer they became so excessively heated that they spoiled the merchandise, and in sudden changes of weather produced sweating, with damage to the lading. They had finally to be withdrawn from service.

#### LOW WEIGHT NOT THE MAIN CONSIDERATION.

E. G. Chenoweth.—I believe that we are now about at the minimum weight of box cars and that the tendency is to increase, and not worry so much about the extra dead weight hauled, but to give more consideration to keeping the car in revenue service more days of its life instead of having it stand on repair tracks.

Mr. Rink states that it is the whim of the designer that occasions so many different lengths of box cars. In my experience in designing equipment for several different railways the proper length of a car was held as a serious question and good reasons were developed in the freight traffic department before the designer received the principal dimensions from which to work.

The standardization of a design of box car will have a tendency to decrease the variation in weight. Of two designs of car built within a year of each other by different railways one, a 60,000-lb. capacity car, had a light weight of 48,000 lbs. while the other, of 80,000-lb. capacity, had a light weight of 36,000 lbs. Moreover, both railways were satisfied with their designs.

The trouble experienced by water following beading or grooves in horizontal sheathing and then passing into the car could, I think, readily be overcome by beveling the top outside corner of each board. This would eliminate the gutter effect of the sheathing where it is not entirely tight.

#### DIFFICULTY IN SECURING SUITABLE LUMBER OVERCOME.

W. S. Atwood.—The first steel frame car which we built was considerably heavier than the present ones, weighing 41,000 lbs. This was partly due to the fact that the car was constructed from material which was in stock, no special material having been ordered. The present car weighs less than 36,000 lbs.

With the first cars of this type there was some difficulty experienced in securing the proper grade of lumber and also in properly drying it, as, owing to its thickness, it had to remain in the dry kilns longer than was necessary in the case of the thinner sheathing used on the outside sheathed car. On this account the car companies were not, in all cases, equipped with sufficient dry kiln capacity. The lumber dealers, however, have met the car builders in attempting to prepare a satisfactory grade of lumber and no difficulty is now encountered.

The adoption of a car with standard inside dimensions would be a matter of considerable importance to the car builders, as material could be stocked and would be available for building cars required for quick delivery for any of the railways which had adopted this type of car.

#### ALL-STEEL BOX CARS.

C. A. Seley.—About 15 years ago three factors influenced some progressive railroads toward the larger introduction of steel in the frame work of freight cars. These were, increased capacities, greater structural strength to withstand operating stresses, and the approaching equalization of costs of steel and car lumber, particularly for framing. My own idea is that steel under-

frames should be confined to the strengthening and rebuilding of the present wooden superstructure house cars. For new cars, I believe there is now no good argument against steel for the complete framing, so combined that the sides will assist in carrying the load. The question then arises as to how far to go with the use of steel for such parts of the car as merely contain or shelter the load. Manifestly, floors must continue to be made of wood to enable blocking of the lading. In my opinion, steel will be the ultimate construction used in box cars, but doubtless it will be slow in general adoption on account of the still favorable balance in favor of the cost of wood for lining and sheathing, and in combination with steel plate for roofing. When the all-steel box car does come, it will have to be arranged with ventilation features to prevent damage to lading from sweating and from accumulation of excessive heat which may unfavorably affect many high grade commodities.

Both writers have discussed the advisability of the standard car. I doubt very much if this idea will ever be consummated, even to the extent of the standard material idea advanced by Mr. Burnett. The Master Car Builders' Association has standardized the parts essential to interchange, and the government has standardized safety appliances, but we all know that very few of the M. C. B. standards are really standard in exact detail, and the Interstate Commerce Commission safety appliances necessarily give considerable range of dimensions and application within which their requirements may be fulfilled.

**CHICAGO PASSENGER TRAFFIC.**

Some interesting tables showing the daily passenger traffic in and out of Chicago by train, car and passenger movements, have been collected by Bion J. Arnold, consulting engineer, and are included as a statistical appendix in his report on the Chicago terminal situation presented to a city council committee on November 18. The tables, published herewith, show that the Illinois Central handles the largest suburban traffic, with 40,757 passengers a day, the North Western the second largest, with 32,583, and the Rock Island the third, with 16,424. The Chicago, Milwaukee & St. Paul handles the largest through passenger traffic, a total of 7,156 daily, and the Illinois Central has the largest combined passenger traffic. The tables follow:

**DAILY PASSENGER TRAIN MOVEMENT.**  
Chicago Passenger Stations.

Stations and Roads.	Through.			Suburban.			Grand Total.
	In.	Out.	Total.	In.	Out.	Total.	
<b>Union—</b>							
C. B. & Q.	15	16	31	33	30	63	94
P. C. C. & St. L.	10	10	20				20
P. Ft. W. & C.	18	20	38	10	6	16	54
C. & A.	10	10	20				20
C. M. & St. P.	27	31	58	17	16	33	91
<b>Total</b>	<b>80</b>	<b>87</b>	<b>167</b>	<b>60</b>	<b>52</b>	<b>112</b>	<b>279</b>
<b>Grand Central—</b>							
B. & O.	7	7	14	2	2	4	18
C. G. W.	4	4	8				8
P. M.	6	6	12				12
<b>Total</b>	<b>17</b>	<b>17</b>	<b>34</b>	<b>2</b>	<b>2</b>	<b>4</b>	<b>38</b>
<b>C. &amp; N. W.</b>							
<b>Total</b>	<b>60</b>	<b>61</b>	<b>121</b>	<b>96</b>	<b>93</b>	<b>189</b>	<b>310</b>
<b>La Salle—</b>							
L. S. & M. S.	17	20	37	18	18	36	73
C. R. I. & P.	16	15	31	38	37	75	106
C. I. & S.	3	3	6				6
N. Y. C. & St. L.	3	3	6				6
<b>Total</b>	<b>39</b>	<b>41</b>	<b>80</b>	<b>56</b>	<b>55</b>	<b>111</b>	<b>191</b>
<b>Dearborn—</b>							
A. T. & S. F.	7	8	15				15
C. & W. Ind.				11	11	22	22
G. T.	3	3	6	4	4	8	21
C. & O.	12	11	23				6
C. & E. I.	8	8	16				16
Monon	7	5	12				12
Erie	8	9	17				12
Wabash	10	9	19	3	4	7	26
<b>Total</b>	<b>54</b>	<b>50</b>	<b>104</b>	<b>20</b>	<b>22</b>	<b>42</b>	<b>146</b>
<b>Illinois Central—</b>							
I. C.	17	17	34	143	145	288	322
Soo Line	7	7	14				14
M. C.	15	14	29				29
C. C. C. & St. L.	4	4	8				8
<b>Total</b>	<b>43</b>	<b>42</b>	<b>85</b>	<b>143</b>	<b>145</b>	<b>288</b>	<b>373</b>
<b>Grand total</b>	<b>293</b>	<b>298</b>	<b>591</b>	<b>380</b>	<b>372</b>	<b>746</b>	<b>1337</b>

**DAILY PASSENGER CAR MOVEMENT.**  
Chicago Passenger Stations.

Stations and Roads.	Through.			Suburban.			Grand Total.
	In.	Out.	Total.	In.	Out.	Total.	
<b>Union—</b>							
C. B. & Q.	133	126	259	151	135	286	545
P. C. C. & St. L.	65	65	130				130
P. Ft. W. & C.	119	115	234	32	19	51	285
C. & A.	64	66	130				130
C. M. & St. P.	205	139	344	60	53	113	457
<b>Total</b>	<b>586</b>	<b>511</b>	<b>1097</b>	<b>243</b>	<b>207</b>	<b>450</b>	<b>1547</b>
<b>Grand Central—</b>							
B. & O.	40	40	80	7	6	13	93
C. G. W.	26	26	52				52
P. M.	37	37	74				74
<b>Total</b>	<b>103</b>	<b>103</b>	<b>206</b>	<b>7</b>	<b>6</b>	<b>13</b>	<b>219</b>
<b>C. &amp; N. W.</b>	<b>394</b>	<b>391</b>	<b>785</b>	<b>424</b>	<b>421</b>	<b>845</b>	<b>1630</b>
<b>La Salle—</b>							
L. S. & M. S.	139	138	277	88	89	177	454
C. R. I. & P.	75	104	179	174	166	340	519
C. I. & S.	18	12	30				30
N. Y. C. & St. L.	23	22	45				45
<b>Total</b>	<b>255</b>	<b>276</b>	<b>531</b>	<b>262</b>	<b>225</b>	<b>517</b>	<b>1048</b>
<b>Dearborn—</b>							
A. T. & S. F.	46	54	100				100
C. & W. Ind.	42	43	85	31	29	60	60
G. T.	10	10	20	22	24	46	131
C. & O.	78	77	155	6	12	18	20
C. & E. I.	39	41	80				80
Monon	45	31	76				76
Erie	58	43	101	6	8	14	115
Wabash							
<b>Total</b>	<b>318</b>	<b>299</b>	<b>617</b>	<b>65</b>	<b>73</b>	<b>138</b>	<b>755</b>
<b>Illinois Central—</b>							
I. C.	113	111	224	626	619	1245	1469
Soo Line	41	41	82				82
M. C.	118	105	223				223
C. C. C. & St. L.	26	27	53				53
<b>Total</b>	<b>298</b>	<b>284</b>	<b>582</b>	<b>626</b>	<b>619</b>	<b>1245</b>	<b>1827</b>
<b>Grand total</b>	<b>1954</b>	<b>1864</b>	<b>3818</b>	<b>1627</b>	<b>1581</b>	<b>3208</b>	<b>7026</b>

**DAILY PASSENGER MOVEMENT.**  
Chicago Passenger Stations.

Stations and Roads.	Through.			Suburban.			Grand Total.
	In.	Out.	Total.	In.	Out.	Total.	
<b>Union—</b>							
C. B. & Q.	2195	2200	4395	7120	5140	12260	16655
P. C. C. & St. L.	934	1218	2152				2152
P. Ft. W. & C.	1329	1482	2811	498	303	801	3612
C. & A.	1227	1404	2631				2631
C. M. & St. P.	3568	3588	7156	1644	1618	3262	10418
<b>Total</b>	<b>9253</b>	<b>9892</b>	<b>19145</b>	<b>9262</b>	<b>7061</b>	<b>16323</b>	<b>35468</b>
<b>Grand Central—</b>							
B. & O.	340	310	650	210	260	470	1120
C. G. W.	185	306	491				491
P. M.	1141	893	2034				2034
<b>Total</b>	<b>1666</b>	<b>1509</b>	<b>3175</b>	<b>210</b>	<b>260</b>	<b>470</b>	<b>3645</b>
<b>Total C. &amp; N. W.</b>	<b>8300</b>	<b>8511</b>	<b>16811</b>	<b>17000</b>	<b>15583</b>	<b>32583</b>	<b>49394</b>
<b>La Salle—</b>							
L. S. & M. S.	1909	2651	4560	4242	4052	8294	12854
C. R. I. & P.	2292	2160	4452	8160	8264	16424	20876
C. I. & S.	299	379	678				678
N. Y. C. & St. L.	368	326	694				694
<b>Total</b>	<b>4868</b>	<b>5516</b>	<b>10384</b>	<b>12402</b>	<b>12316</b>	<b>24718</b>	<b>35102</b>
<b>Dearborn—</b>							
A. T. & S. F.	1000	1000	2000				2000
C. & W. Ind.				2699	2126	4825	4825
G. T.	631	635	1266	1172	1175	2347	3613
C. & O.	240	215	455				455
C. & E. I.	1750	1745	3495	300	400	700	4195
Monon	442	420	862				862
Erie	450	450	900				900
Wabash	560	430	990	185	280	465	1455
<b>Total</b>	<b>5073</b>	<b>4895</b>	<b>9968</b>	<b>4356</b>	<b>3981</b>	<b>8337</b>	<b>18305</b>
<b>Ill. Central—</b>							
I. C.	2365	2525	4890	20696	20061	40757	45647
Soo Line	410	404	814				814
M. C.	1507	1254	2761				2761
C. C. C. & St. L.	875	800	1675				1675
<b>Total</b>	<b>5157</b>	<b>4983</b>	<b>10140</b>	<b>20696</b>	<b>20061</b>	<b>40757</b>	<b>50897</b>
<b>Grand total</b>	<b>34317</b>	<b>35306</b>	<b>69623</b>	<b>63926</b>	<b>59262</b>	<b>123188</b>	<b>192811</b>

A summary showing the total traffic in daily train, car and passenger movements by station groups is as follows:

**SUMMARY OF RAILROAD PASSENGER TRAFFIC—TOTAL DAILY TRAIN, CAR AND PASSENGER MOVEMENTS.**  
Chicago Passenger Stations.

Stations.	Through.			Suburban.			Total Through and Suburban.		
	Trains.	Cars.	Pass.	Trains.	Cars.	Pass.	Trains.	Cars.	Pass.
Union	167	1097	19145	112	450	16323	279	1547	35468
Grand Central	34	206	3175	4	13	470	38	219	3645
C. & N. W.	121	785	16811	189	845	32583	310	1630	49394
La Salle Street	80	531	10384	111	517	24718	191	1048	35102
Dearborn	104	617	9968	42	138	8337	146	755	18305
Ill. Central	85	582	10140	288	1245	40757	373	1827	50897
<b>Grand total</b>	<b>591</b>	<b>3818</b>	<b>69623</b>	<b>746</b>	<b>3208</b>	<b>123188</b>	<b>1337</b>	<b>7026</b>	<b>192811</b>

**CONVERTIBLE STOCK AND BOX CAR.**

There are a number of roads where traffic conditions during certain times of the year are such that the transverse movement of empty box and stock cars amounts to a considerable item. This is well illustrated by the traffic on the Frisco lines during the calendar years 1911 and 1912. The mileage of empty stock cars out of St. Louis and Kansas City alone amounted to 4,511,710 miles each year. An equal number of empty box cars was hauled to those points from the stock-

the past six years about 3,000 cars have been treated in this way with considerable success, but the car construction was such that the sides could not be made entirely proof against leakage.

Believing that a car could be built that would readily permit of satisfactory conversion, E. D. Levy, assistant general manager of the Frisco, has been studying the question for a number of years. He has now obtained a car that seems to meet the requirements. It is built in the same manner as a box car, and with the exception of the slats, is leakproof in



Interior of the Car When Prepared for Merchandise Shipments.



Interior of the Car When Prepared for Shipments of Stock.

loading territory for bringing back general merchandise. This made a total empty car mileage of 9,023,420 miles each year, which was moved at a cost of about \$162,000. In order to obtain box cars when the shortage became acute, it had been the custom to take stock cars, thoroughly cleaning and disinfecting them, and covering the roof and entire inside surface of the cars with tar paper, at a cost of \$5 to \$6 per car, and loading them with certain classes of freight. During

every respect. To convert this car to a box car it is only necessary to cover the opening between the slats with an odorless asphalt paper, as indicated in the photograph. The cost of doing this is \$1.50 per car for labor and material, which with the 50 cents charged for cleaning and disinfecting, as required by the government, makes a total of \$2 per car. This type of car could also be profitably used by the south-western cotton carrying roads which in the spring months-



Convertible Box and Stock Car for the Frisco.

when a great deal of stock is moving from the southern ranges to the more northerly feeding grounds, are all chronically short of stock cars, and which, when the cotton crop is

this opposed hauling of empty stock and box cars, it has been estimated that 2,000 convertible box and stock cars on the Frisco would relieve at least half of it; or, in other words

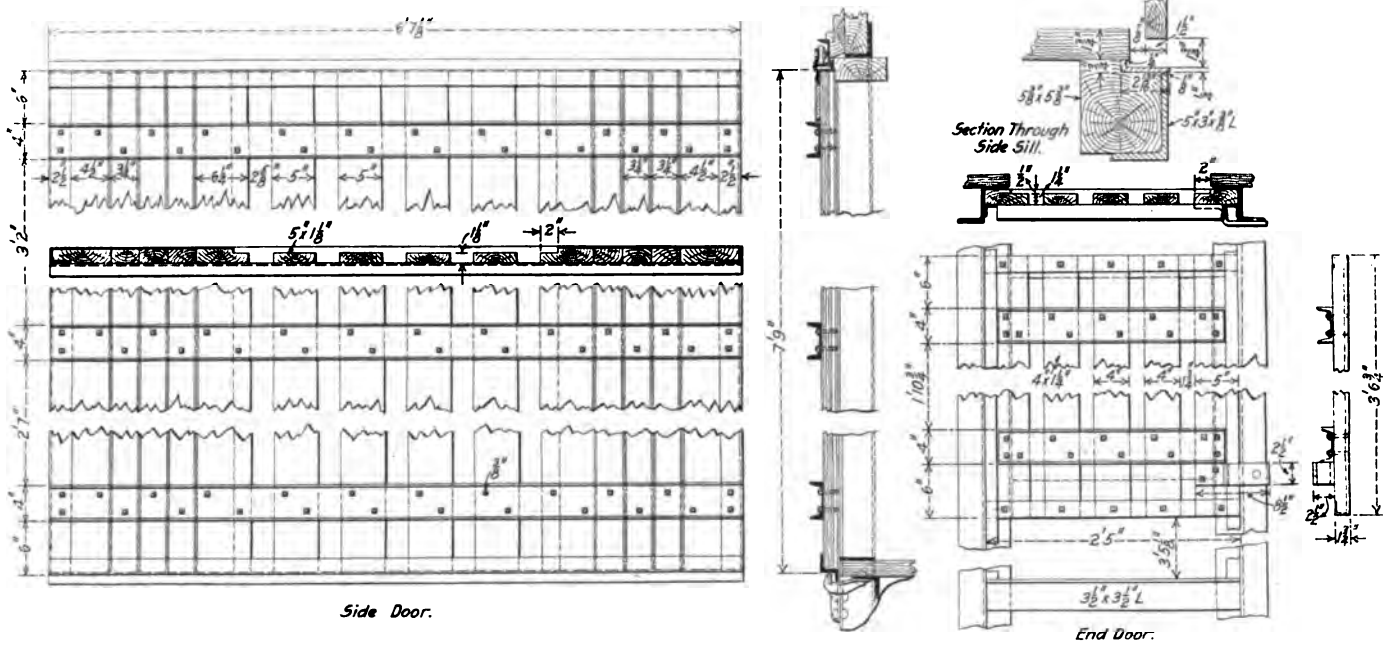

Doors of the Frisco Convertible Box and Stock Car.

being moved are short of box cars, having a surplus of stock cars on hand.

save \$81,000 in transportation costs. The cost of cleaning and conversion of these 2,000 cars will be approximately \$46,000 each year, which, deducted from the saving and trans-

While it would be practically impossible to eliminate all of

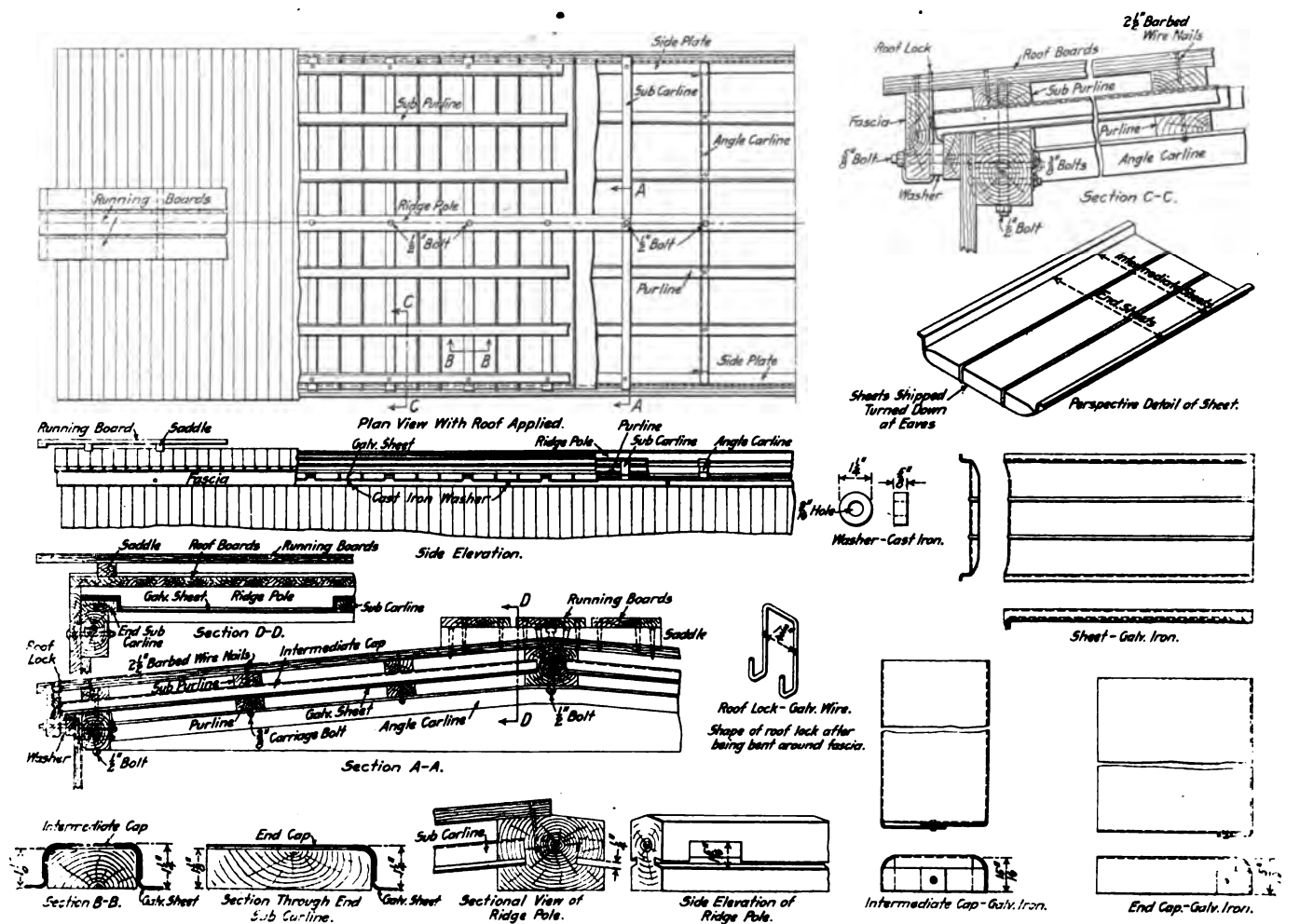

Roof Details of the Frisco Convertible Box and Stock Car.

portation costs of the empty car mileage, gives \$35,000. By loading these 2,000 convertible cars in both directions and saving one-half of the empty car mileage, they would do the work of 3,000 box or stock, or box and stock cars, preventing the necessity of owning 1,000 cars. These 1,000 cars would represent an investment of about \$1,000,000; the saving in interest charges being \$60,000, in maintaining, \$50,000, and depreciation, \$60,000, making a net saving in the total operating costs and capital account of \$205,000, or approximately \$102.50 per car per year.

These convertible cars may be used for general merchandise, cotton, hay and in fact all freight moving in packages, bales, boxes, barrels or other containers, and will be a large factor in increasing the average number of loaded cars per train mile, and the gross and net tons per train mile. The car is designed for a capacity of 80,000 lbs., having the outside steel frame superstructure. The general construction is the same as that for the other box cars of this capacity that have recently been built for the Frisco and which were described in detail in the *Railway Age Gazette*, October 3, 1913, page 609. The difference in detail construction between the convertible stock and box cars and the box cars is in the roof, the siding, the flooring at the corners, and the doors. The Type B Improved Winslow roof and angle steel carlines with the X-brace at each end, as made by the Chicago-Cleveland Car Roofing Company, is used. Tests on this type of roof have shown it to be cooler by an average difference of about 4 deg. than the single or outside roof throughout the very hot weather, and this feature is of advantage in stock cars, especially when carrying hogs. The side framing is made solid down to within about 5 ft. 3 in. from the floor. The slatting is 1½ in. thick and 5½ in. wide. It is fastened to the posts and braces by ½ in. carriage bolts. The opening between the slats is 1¾ in. The end construction is the same as that for the box cars. It will be noticed in the section through the side sill that the floor of the car is ½ in. above the bottom of the lowest slat, and an opening of ⅞ in. is made between the floor and the side posts and braces. This is to permit of drainage of the car when being used as a stock car, and to also allow for the odorless asphalt paper to be extended down below the floor, when converting to a box car, so as to insure positive drainage from the sides in wet weather. Two strips of paper are used on the inside of the car to cover all the openings between the slats, and are lapped so that the moisture cannot work through to the inside of the car. The paper is held in place by laths used as cleats and nailed to the slats with small nails having only sufficient penetration to hold the paper in place. The slats in the door are ½ in. thinner than the edges of the door, in order to permit the paper being applied without interfering with the action of the door.

The car was built at the company's shops, and selling rights for the convertible features have been granted the Chicago-Cleveland Car Roofing Company, the patent for which has been applied for by Mr. Levy.

The general dimensions are as follows:

Inside length.....	40 ft.
Length between end sills.....	40 ft. 11 in.
Length over running boards.....	42 ft. 1 in.
Length over striking castings.....	42 ft. ¼ in.
Center to center of bolsters.....	31 ft.
Width inside.....	8 ft.
Height from top of floor to under side of carline.....	8 ft.
Height from rail to top of floor.....	4 ft. 1¼ in.
Height from rail to eaves.....	12 ft. 5½ in.
Width of side door opening in clear.....	6 ft.
Height of side door opening in clear.....	7 ft. 6½ in.
Truck wheel base.....	5 ft. 6 in.

**STREET CAR LINES IN PARIS.**—The 40 year concession granted to the General Omnibus Company of Paris on June 1, 1910, stipulated that by June 1, 1913, all the horse-car, steam, and compressed-air street car lines within the walls of Paris must be converted into electric lines, and that underground circuits only should be used on all newly relaid lines.

**CAB WINDOW VENTILATOR.**

One of the greatest annoyances to a locomotive engineer in the winter time is the collection of frost on the cab window, requiring him to keep his side window open for the observation of signals. In order to overcome this, and to provide ventilation in front of the cab when the window is closed, the window shown in the accompanying illustration has been invented by Charles M. Goodrich, Clinton, Iowa. The window is set out at an angle

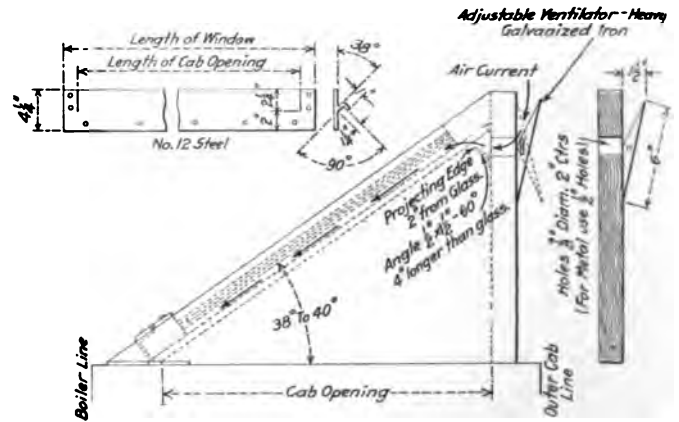

Arrangement of Frost Eliminating Device on a Cab Window.

of 38 to 40 deg. from the point where the cab meets the boiler. A series of ⅞ in. holes are placed in the extended side of the cab just inside of the window, through which air is forced by an adjustable ventilator. A small vane is placed on the inside edge of these holes to further guide the air against the inside surface of the glass. By doing this the temperature of the air on both sides of the glass will be kept very nearly the same, and condensation in cold weather will be prevented. The ventilator is

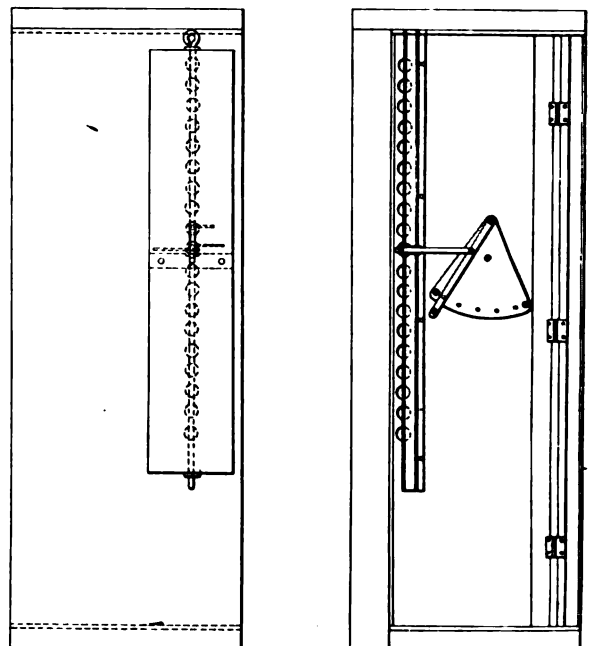

Cab Window Fitted with Frost Eliminating Device.

pivoted so that the amount of air passed through these holes may be regulated. There are six positions of adjustment from the totally closed position to the maximum opening. The ventilator is operated through a series of small levers and a quadrant, as indicated in the drawing. This window does not in any way interfere with the passage of a man from the cab to the running board, and it has found extensive use on some large railways operating west of Chicago.

## A. H. SMITH.

Alfred H. Smith was elected president of the New York Central & Hudson River and the Lake Shore & Michigan Southern, to take effect January 1, 1914, at a meeting of the boards of directors held in New York on Wednesday, December 10. Undoubtedly the other roads in the system will follow the same course at the earliest opportunity.

Mr. Smith was born and reared in the west and spent the first 23 years of his railway experience on the Lake Shore, leaving there in 1902 to go to New York as general superintendent on the New York Central & Hudson River. By his very thorough and extensive knowledge of both the western and the eastern parts of the New York Central system he is unusually well equipped for the work which he is about to take up. No man could have been selected who has a better knowledge of the condition and personnel of the entire system than Mr. Smith.

From the time that he entered the service of the Lake Shore he was noted for his rugged, ready, forceful personality. Because of these characteristics everything that he set out to do he accomplished. In addition to having a great capacity for seeing and comprehending every detail, he has the faculty of deciding quickly questions which come before him. He is a big man physically, as well as mentally, and commands respect. He has always been known by those who were close to him as a good friend. Among the enginemen, trainmen and yardmen on the Lake Shore he has always been spoken of as Al Smith. He knows large numbers of the men on the road and has the faculty to a marked degree of remembering people with whom he comes in contact.

Mr. Smith received his early training under John Newell, who was president of the Lake Shore & Michigan Southern and was one of the greatest factors in upbuilding that road in the early stages of its development. Because of Mr. Smith's forceful personality, his grasp of details and outspoken manner, he was one of the very few men who were able to gain the entire confidence of Mr. Newell.

The New York Central Lines need just such a man as Mr. Smith. As the parts of the system have developed, there has come about a pressing need for improving the organization so that the various parts may be more thoroughly tied together in one strong and efficient unit. Since Mr. Smith's appointment as senior vice-president, early in the present year, he has gradually taken over some of the duties of the president and developments indicate that he has some very definite ideas as to the need for a more effective central organization. If he brings this about there is little doubt that the New York Central Lines will become a highly efficient working unit—a thing much to be desired.

Mr. Smith is about 49 years of age and his entire railroad

experience has been on the New York Central Lines. He entered the service of the Lake Shore & Michigan Southern at Cleveland, in 1879, as a messenger boy. Later he was connected with the purchasing agent's office and from there went to the engineering department, and for several years worked on a change of grade and a reconstruction of the Lake Shore west of Toledo. During this time he was foreman and later general foreman of construction work. In October, 1890, he was made superintendent of the Kalamazoo division. One year later he was transferred in the same capacity to the Lansing division, and in February, 1893, was made superintendent of the Franklin division, with office at Youngstown, Ohio. From July, 1897, to April 1, 1901, he was superintendent of the Michigan division, at Toledo, after which he became assistant general superintendent, with headquarters at Cleveland. On June 17, 1901, he was made general superintendent of the road, and in February,

1902, left the Lake Shore to become general superintendent of the New York Central & Hudson River. This position he held until July 1, 1903, when he was promoted to the position of general manager. In June, 1906, he was made a vice-president of the New York Central & Hudson River, and on April 15, 1912, was made vice-president also of the other New York Central lines. In March, 1913, he became senior vice-president of the New York Central Lines in charge of operation, maintenance and construction.



A. H. Smith.

**A NOTABLE GERMAN STATION.**—German railway administrations are famous for their stations, and amongst them the Baden State Railways deserve special mention for their recent achievements in this direction. Only a few weeks ago the administration brought into operation its new station at Basle, the largest on its system, yet on October 20 it celebrated the completion of another great work, when the new station at Karlsruhe, the capital of the Duchy, was ceremoniously opened. Within the last two years no less than seven important new stations, representing an outlay of over \$30,-

000,000, have been opened on the Baden railway system, and the interest on this large sum amounts to \$1,250,000 per annum, while the increased annual expenditure in connection with these stations amounts to no less than \$1,750,000. At Karlsruhe, where the headquarters of the railway administration are situated, the question of rearranging the station has been under discussion for the past 20 years, and the cramped conditions which formerly hindered the development of the city and the work of the railway have now been surmounted by the removal of the station to another site. The new station and its accessories cover an area of nearly 246 acres, and the new works have involved the construction of 16 railway bridges and 39 subways. On the whole scheme, which includes \$2,598,750 for land, \$1,021,050 for bridge works, \$2,285,525 for the station itself, and \$395,925 for locomotive shed, repair shops, signal boxes, etc., a total of \$8,895,000 has been spent.



# THE FREIGHT RATE ADVANCE HEARINGS.

Roads Continue Their Case by Testimony Showing That as Gold  
Has Depreciated Railroad Rates Have Not Been Readjusted.

The rate advance hearings were resumed at Washington before Commissioner Harlan on Wednesday. Counsel for the Manufacturers of Cement, Lackawanna Steel Company, Eastern Paving Brick Association, Northwestern Millers' Association and various shoe manufacturers asked permission to intervene and filed protests against specific rates. The following abstract from the protest of the cement manufacturers indicates the nature of the protests.

"Complainants aver that with the exception of some slight reductions made in 1912 the general cement rate structure from the Lehigh Valley cement region to consuming points in official classification territory has been in effect since 1907 (at which time there was a general increase of about six per cent. in cement rates, except to New England) and was and is so constructed as to yield to the participating carriers very substantial and satisfactory revenues. Complainants further aver that the cement business has been extremely profitable to the participating carriers because they secure not only the remunerative rates on outbound cement above referred to, but also very remunerative rates on inbound plaster, limestone and coal. As substantial evidence of the magnitude of this traffic and of its value to the interested carriers, complainants aver that statistics kept by them show that the railroads serving complainants' manufacturing plants moved on an average for the years 1909 and 1910 the following traffic to and from the said plants:

	Tons.
Gas Coal .....	1,225,500
Steam Coal .....	837,105
Plaster .....	121,809
Limestone .....	1,015,928
Cement .....	4,880,000
Miscellaneous Freight .....	250,000
Total .....	8,330,342

yielding an estimated revenue to the carriers of \$12,313,000.

"Complainants further aver that the plaster traffic has been very remunerative to the participating carriers and has yielded to them under the present rates which have been in effect for a long period of time very substantial and satisfactory revenues."

## RELATION OF RAILWAY CHARGES TO THE SUPPLY OF MONEY AND CAPITAL.

These protests having been filed the railroads continued their case by putting on the stand Charles A. Conant, author of *The Principles of Money and Banking*. An abstract of Mr. Conant's testimony is given below.

The problem of changes in the purchasing power of money is an intricate one, but derives its intricacy almost as much from the necessity of care in stating terms and conclusions as from any lack of simplicity in the principles involved.

The monetary law which in the United States prescribes that 25.8 grains of gold nine-tenths fine shall be known as a dollar, does nothing to fix the value of the dollar in relation to other things. It simply establishes a sort of barometer by which the relations of other things are measured, like the yard-stick for length or the bushel for bulk. If one bushel of wheat is worth today two bushels of potatoes and the price of a bushel of wheat is \$1, it is more convenient to refer the value of the bushel of potatoes to the gold dollar than it would be to speak always in comparisons of wheat and potatoes, or steel rails, or pairs of shoes. But the use of the dollar as a denominator of value in this manner by no means precludes constant changes in the value of the dollar in relation to other things. Indeed, when wheat rises from \$1 to \$1.50 per bushel, the value of the gold dollar in relation to wheat has fallen to  $66\frac{2}{3}$  per cent. of its former value.

This is exactly the ratio in which the purchasing power of

the dollar has fallen during the last fifteen years, according to Professor Irving Fisher.

It was contended by many, when the gold dollar was increasing in purchasing power, that this was due to the increased productive power of labor and machinery—in other words, that the labor compensated by a given number of dollars produced a larger quantity of goods, of which each unit could, therefore, be sold at a lower price. That such a change has occurred is undoubtedly true, and it has tended in a marked degree to reduce the labor cost of manufactured articles within our generation. If, therefore, we encounter the fact that, in spite of this persistent increase in the productive powers of human society, the price of goods has not fallen upon the average in recent years, but that more dollars are required for the purchase of almost any given commodity than was the case sixteen years ago, ten years ago, or even four years ago, it is evidence of the depreciation of the purchasing power of the dollar.

If it requires more dollars today to purchase a given amount of goods or services, then in relation to those goods or services there has been a depreciation in the value of money. Such a decline in the purchasing power of gold, which is now the standard money in practically every civilized state, in itself constitutes a depreciation of gold. This statement is not a discussion of cause or effect—whether the increase in the supply of gold has caused a rise in prices or whether the rise in prices is due to entirely different causes. The fact remains that gold has depreciated in relation to nearly all other commodities.

It is this fact which faces the railways as well as other producers and investors, and with which they have had to deal in recent years. Those producers who have been able to operate in a market where they were free to use their own judgment and economic power in fixing prices or wages, have been able to adapt themselves more or less rapidly to the depreciation in the purchasing power of the dollar. If they were workers for wages, they have been able to demand increases in their wages to enable them to meet the increased cost of living, as expressed in dollars. If they were dealers in articles of retail trade, they have been able to advance the prices of those articles from time to time to cover the increased cost of obtaining them at wholesale or directly from the producer. By this means, they have succeeded in effecting the economic adjustment of their position to the diminished purchasing power of the dollar. The process has been gradual, although the figures which I shall soon present will show that it has been rapid. The fact that it has been gradual, and that wage-earners and merchants have been able to adapt themselves gradually to the change, has, to a certain extent, concealed its real economic significance.

What would have been said if it had been proposed by law in 1896 to require the railways to reduce their rates from 35 to 50 per cent. within 15 years? What would have been the protests and what would have been the unsettlement of the value of railway securities in the market if an order had been made by this commission to any such effect? But the silent and irresistible processes of economic forces have reduced the money value of these rates in something like this proportion within the past 16 or 17 years, while the railways have suffered a steady impairment of their earnings, and for a number of years past have been restricted by statute law from adapting themselves, like other industries, to the new monetary conditions.

To return to my essential point, it is, in substance, that the purchasing power of the dollar over the great mass of commodities has permanently fallen since the present schedule of passenger and freight rates was established. Even in a free market, unrestricted by statute law, the effect of changes in

the purchasing power of money is not simultaneously felt by all classes in the community. If such changes did act simultaneously and automatically upon all classes, then the only difference caused by such changes would be differences in the expression of wages and prices in terms of money. Unfortunately, however, for certain classes, they are not able to secure an adjustment of their wages and prices so quickly as other classes. Hence come about inequalities, by which those who are able most quickly to adjust themselves to the new conditions reap profits and advantages over those who are not able to adjust themselves so promptly.

It is obvious that those persons who had fixed incomes expressed in dollars would find it difficult, if not entirely impossible, to avoid losses from the new conditions.

It is now generally admitted that the most definite and trustworthy method of ascertaining changes in general prices is through index numbers. These index numbers are nothing, in effect, but the reduction of a great variety of prices, dealing with different commodities measured in different ways—some by pounds, some by tons, some by bulk, and some by the value of the labor which they represent—to a common denominator.

I submit below a table giving the index numbers obtained by Professor Falkner for a series of years, with the percentage by which average annual prices for 1912 exceed those of previous years. It will be observed that average prices in 1912 were 48.9 per cent. higher than in 1897; 47.8 per cent. higher than in 1896; and 18.2 per cent. higher than in 1904. Analysis of the details of prices by classes of products shows that under the head of metals and implements, the index number advanced from 86.6 per cent. in 1897 to 126.1 per cent. in 1912; lumber and building materials, from 90.4 per cent. in 1897 to 148.2 per cent. in 1912, or an increase of more than 60 per cent.

Year or Month.	Relative prices of all Commodities.	Per Cent. higher in 1912 than in each preceding year.
1890	112.9	18.3
1891	111.7	19.6
1892	106.1	25.9
1893	105.6	26.5
1894	96.1	39.0
1895	93.6	42.7
1896	90.4	47.8
1897	89.7	48.9
1898	93.4	43.0
1899	101.7	31.4
1900	110.5	20.9
1901	108.5	23.1
1902	112.9	18.3
1903	113.6	17.6
1904	113.0	18.2
1905	115.9	15.3
1906	122.5	9.1
1907	129.5	3.2
1908	122.8	8.8
1909	126.5	5.6
1910	131.6	1.5
1911	129.2	3.4
1912	133.6	...

Referring to the simple average, which takes as a standard of 100 the average wholesale price of the ten years 1890-1899, both inclusive, we obtain some interesting results. It appears that in 1880, the first year after the resumption of specie payments, prices were much higher than the average of 1890-1899. An almost uninterrupted decline occurred, however, until 1896, when the index number fell to 90.4, or more than 40 per cent. below the prices of 1880. With the resumption of business activity in 1898, the index number begins to rise until it has attained 110.5 in 1900. There was then a slight recession, followed by a slow recovery, which carried the index number for 1904 to 113. Then began the rapid upward movement of the past eight years—interrupted by the depression of 1908—which finally advanced the index number for the year 1912 to 133.6. This is an increase of nearly eleven points over the low point of 1908, and of 40.2 points over the index number of 1898.

English index numbers bear out the American in a general way, although their range of fluctuation is not quite so wide.

The total banking resources of the country per capita amounted in 1900 to \$140; in 1908 to \$201; and in 1912 to \$235.

The last-named figure is an increase of 67.68 per cent. over that of the year 1900. If this increase were due exclusively to increase in productive capacity, it would mean not only that laborers in factories had greatly increased their productive power by the aid of machinery, but that the average increase had been so great as to amount to nearly 68 per cent. when spread over the population engaged in simple manual labor and in personal services. Obviously, it requires an optimistic draft upon the imagination to assume any such phenomenal increase in the producing power of the community, and no such result is indicated by known additions to accumulated wealth.

To test the question whether the volume of goods dealt in has increased in any such ratio as banking resources, I have divided the ton mileage of the railways in 1900 and in 1912 by the population in those years and find an increase per capita of 48.14 per cent., instead of the 68 per cent. shown in banking power. A better test perhaps is afforded—so far as these figures constitute a test—by the number of tons of freight carried. Here the increase per capita is a little less than 34 per cent., or only one-half the increase in banking power.

THE PURCHASING POWER OF FREIGHT EARNINGS.

It is pertinent to this enquiry to set side by side with these changes in the purchasing power of money the changes which have taken place in the rate of compensation received by the railways for passengers and freight. Fortunately, the system of statistics established by the Interstate Commerce Commission permits an ascertainment of the average receipts per unit of service by the railways of the United States. Taking the receipts for freight alone per ton-mile and expressing them in mills, or tenths of a cent, it appears that this average of ton-mile receipts varied only within narrow limits during the whole 16 years from 1896 to 1912. In 1896, the average receipts per ton-mile were 8.06 mills; in 1912, they were 7.43 mills. This represented a decline of 63 hundredths of a mill, or about 7 per cent. This decline in freight receipts, however, was only the decline expressed in terms of money.

Quite different and striking results are obtained if one compares the purchasing power of this money in 1896 with its purchasing power in 1912. Such a comparison is easy and simple under the system of index numbers. In order to determine this ratio of purchasing power, it is only necessary to divide the rate per ton mile by the index number for prices. The result gives the relationship of the ton-mile revenue in purchasing power on different dates, expressed in mills, upon the basis of the average prices from 1890 to 1899. If the receipts per ton-mile in 1896 were 8.06 mills, and wholesale prices bore a ratio to the standard of 90.4 points, the purchasing power of the receipts per ton-mile was 8.92 mills. As the index number of prices advanced, however, even if receipts remained the same in terms of money, the purchasing power of the receipts inevitably fell in a striking ratio.

After the revival of business activity in 1897, receipts per ton-mile declined only slightly, but the index number of wholesale prices increased rapidly. The result was that the purchasing power of the money received for freight fell from a ratio to 8.06 in 1898 down to 6.61 in 1905. Then began another decline, interrupted only by the depression of 1908, which finally carried the ratio of purchasing power of freight receipts in 1912 down to 5.56. When this purchasing power of the receipts per ton-mile is compared with the corresponding figure of 1896, we find a decline of 3.36 mills, or 37.6 per cent. I conclude, therefore, simply as a question of mathematics, and without undertaking to enter into the intricacies of railway accounting or the special demands which have been made upon the railways, that the purchasing power of the moneys which are now paid for freight is approximately 37 per cent. less in the market for commodities than it was in 1896.

From 1903 to 1912 there was a decrease of 17.1 per cent. in the purchasing power of ton-mile earnings, and even from 1908 to 1912 a decline of 9.4 per cent., or nearly twice the proportion

in which it is now asked that permission be given to advance nominal rates expressed in terms of money.

The second broad subject to which I wish to address myself, in considering the present economic position of the railways, is the increased difficulty which they have found in recent years in obtaining new capital for extensions and improvements. One of the fundamental difficulties has been the unusual demand for capital from many sources during the past dozen years and the increased keenness of competition between various forms of investment.

Time was, before the era of industrial consolidations, when the bonds and shares of railways were the principal resource for the investor in finding safe and profitable use for his savings. In recent years, however, new demands have converged upon the supply of available capital in an unusual degree from the conversion of industrial enterprises into stock companies, the absorption and merger of old companies with new, the great extension of the system of local traction lines, the demands of undeveloped countries for railways and industrial equipment, and the remarkable expansion in the calls of governments upon the financial markets for the means of increasing armaments and making public improvements.

This great demand for capital which converges on the principal money markets of the world has effects similar to those produced by great demand upon other commodities—it raises its price. As the price of capital is the rental charged for its use, or the interest rate, this rate has risen in a marked degree in recent years. The influence of this condition may be summarized as follows:

1. New securities can only be sold at lower prices than formerly or must pay higher interest rates on their par value.

2. The prices of outstanding securities fall, making them unsalable in the hands of their holders except at a loss and reducing the assets and the surplus funds of savings banks, other banking institutions, and insurance companies.

3. The seekers of new capital by means of security issues must pay a larger amount in money for its use, and in view of the rise in general prices, must pay more for their materials, thus making necessary a higher rate of earnings than formerly in order to meet fixed charges.

4. Under the conditions of competition for capital thus established, industries of high earning power are able to outbid those of lower earning power for the supply of free capital in the market.

5. Incident to the decline in the purchasing power of money, there is a tendency on the part of investors to shift their investments to those paying higher returns than formerly, in order to meet the increased cost of living, even at the risk of some slight decrease in security.

6. In so far as the decline in the purchasing power of money is recognized in the financial world as a factor likely to be continuously felt, there will be a tendency on the part of investors to refrain from purchasing securities for long terms, paying a fixed income in money.

I have endeavored in this discussion to limit myself to a few simple propositions, which I think are well understood among economists and have been sufficiently proved, so far as such matters are susceptible of exact proof. We have seen that there has been an advance in prices of commodities of a broad and general character. In so far as the advance in prices has been uniform in different industries, and in so far as the increase in the wages of labor has corresponded to the advance in prices, equality of conditions under the present value of the dollar has been established. The railways, however, have not shared in this advance in the money expression of services in any such degree as other industries and wage-earners.

It is worth noting in this connection that if the commercial clients of the railways have in nearly all cases been able to obtain an increase in their receipts in money, corresponding to its diminished purchasing power, these clients have not been

called upon to disburse in freight rates the ratable proportion of their increased charges to the consumer, and have from the enforced rigidity of such rates in terms of money transferred an unearned increment to their own coffers at the expense of the railways. The railways have not adapted their charges, as have other industries, to the change in the purchasing power of money. They have continued to sell their services for an amount which has remained comparatively fixed in money, but has declined greatly in purchasing power. Such additional capital as they have sought by the issue and sale of securities has been obtained on higher terms than in former years, while its purchasing power, in materials and wages, has been much less than in former years. The railways have been in the peculiar position of seeing prices rising all around them, while they have been unable to make advances proportionate to their changed relations to other industries.

If the value of the money received by the railways for their services has so seriously declined in purchasing power as to deprive them of the means of meeting their legitimate charges and obtaining new capital at its present rental price, they are not on an equality with other industries; they are receiving a much less proportionate share of the proceeds of the economic output of the country than that which they formerly received; and they are less capable of contributing their share to equipping this country for unfettered competition with other countries in the field of production and international commerce.

#### WAGE MOVEMENTS.

On Wednesday afternoon J. G. Walber, assistant to the third vice-president of the Baltimore & Ohio, testified as to wage increase. His statement is given below substantially in full.

Estimates for 29 of the 38 railroad systems, parties to this rate proceeding, show an increase in wages for 1913 over 1910 of \$48,618,972.41, due to changes in rates of pay and working conditions.

This figure was obtained as a result of a request to the railroads to take the actual performance for the year ending June 30, 1913, and compare the rates of pay and working conditions prevailing in that period with those in effect in October, 1909, a period prior to the date of any of the important increases subsequently made.

In addition to the increases up to June 30, 1913, careful estimates show that the increases in wages recently granted to the firemen, conductors and trainmen will add not less than \$8,750,000 more to the expenses of the railroads parties to the respective arbitration proceedings, this estimate being based on the volume of business for the calendar year 1912.

The 1910 wage movements were begun by the conductors and trainmen, who had formed an association known as the Eastern Association of General Committees of the Order of Railway Conductors and Brotherhood of Railroad Trainmen.

Late in December, 1909, the management of the eastern railroads was presented with a proposition from these employees for the adoption of revised rates of pay and certain rules governing working conditions, with the request that answers be given on January 20, 1910. At the same time the presidents of the two organizations communicated with the management of the railroads for the purpose of ascertaining whether they would prefer to conduct the negotiations collectively for all the railroads or individually. The managements decided to negotiate individually.

Thereupon the Baltimore & Ohio was selected for opening the negotiations, the reason for such selection being, as stated by the representatives of the employees, that the bases of the Baltimore & Ohio schedules more nearly corresponded with the revised proposition than the schedules of practically every other eastern railroad, also that it meant less of an increase for the Baltimore & Ohio to adopt the proposed rates than any other railroad, with perhaps one exception. It early became apparent that the authority to make settlement rested entirely with the

representatives of the organizations, and that the employees of the individual companies were powerless to make settlements as in the past.

The management of the Baltimore & Ohio Railroad was unable to agree with the representatives of the organizations; thereupon they appealed to the individual employees who authorized them to declare a strike in the event satisfactory terms were not agreed upon.

After such proceeding was concluded, negotiations were resumed, and it being found impossible to reach a settlement the services of the federal mediators, under the Erdman Act, which was then in effect, were requested by the president of the Baltimore & Ohio Railroad Company, the representatives of the employees declining to join in the request. At the request of the mediators the representatives of the employees agreed to conduct negotiations through them, and after negotiations, lasting a week or more, terms of settlement were reached upon a basis which was practically a split between the then existing rates and those requested.

This settlement, it was carefully calculated at the time, increased the rates of pay 5.44 per cent. Effective September 1, 1910, due to the New York Central arbitration award, as explained hereafter, it was necessary to increase by 20 cents per day the yard rates which had been agreed upon in the Baltimore & Ohio settlement. It was also necessary to apply the basis of the Baltimore & Ohio settlement to the Baltimore & Ohio Southwestern. The effect of the adjustment in the yard rates and the adjustment of the Baltimore & Ohio Southwestern schedules was to increase the percentage to 9.05 for the conductors and trainmen for the Baltimore & Ohio system.

While the mediation proceedings were pending on the Baltimore & Ohio, negotiations were opened by the two organizations on the Boston & Maine and the New York, New Haven & Hartford, on which roads settlements were reached on practically the same basis as had been adopted on the Baltimore & Ohio Railroad.

Negotiations were also begun by the presidents of the two organizations on the New York Central. The New York Central was unwilling to adopt the rates agreed upon in the Baltimore & Ohio settlement. The representatives of the organizations took the position that, having agreed to these rates on the Baltimore & Ohio through federal mediation, they could not reasonably agree to any other rates on any other railroad, having declared themselves to both the Baltimore & Ohio officers and the federal mediators that whatever rates were agreed upon for the Baltimore & Ohio would be established upon the eastern railroads so far as the means at their command would accomplish this. However, after prolonged negotiations with the New York Central they finally agreed to an arbitration of their request as applying to that company.

The representatives of the employees in the recent arbitration proceedings, affecting conductors and trainmen, made a statement that approximately 17 railroad companies had agreed to be bound by the New York Central award, and as soon as the award was announced such railroads adopted the same.

Negotiations were also opened on all other railroads with the result that by practically July, 1910, the schedules of practically all the eastern lines for conductors and trainmen had been revised on the basis of the New York Central award with varying dates upon which they were to become effective, some of the effective dates being extended into the year 1911.

It was estimated that the settlement on the New York Central cost 17.4 per cent.; on the Cleveland, Cincinnati, Chicago & St. Louis Railway 12.7 per cent.; on the Lake Shore & Michigan Southern 11.92 per cent.; on the Michigan Central 19.8 per cent.; on the Boston & Maine 19.6 per cent., and the New York, New Haven & Hartford 15 per cent.

Effective April 1, 1910, the Pennsylvania system granted to all their employees, including conductors and trainmen, a flat

increase of 6 per cent., with the exception of yardmen, who received an increase of 8.4 per cent., the percentage for both road and yardmen equaling 7 per cent.

While the Baltimore & Ohio schedules have for years been on the basis of mileage, that, 100 miles or less, 10 hours or less, constituting a day, with some relatively unimportant exceptions, the Pennsylvania Railroad had had two bases of pay for engineers and trainmen, commonly known as a high rate day applying to runs of over 100 miles with overtime after twelve hours, and a low rate day applying to runs of less than 100 miles with overtime after eleven hours. These rates were not uniformly applied, but their application varied according to the class of service, that is, whether through or local, and according to the conditions on the several divisions. The adjustment of 6 per cent. placed their runs on practically the same basis as the rates granted in both the Baltimore & Ohio settlement and the New York Central award, but on account of the overtime limits which they previously employed the employees considered they would not fare so well compared with other neighboring lines as they had formerly; also the yard rates awarded in the New York Central arbitration were higher than the rates the Pennsylvania lines were paying, including the 6 per cent. increase. The employees declined to accept this settlement, and on July 14 negotiations were broken off, the men notifying the company that they would leave the service within forty-eight hours. Several days later it being apparent that there was a lack of understanding, conferences were resumed and further adjustments made effective from June 1, 1910, through which additional increases amounting to 4.4 per cent. in road service and 6.9 per cent. in yard service were granted. These coupled with the previous adjustments produced increases of 12.35 per cent. for the conductors and trainmen on the Pennsylvania lines east. The settlement made on the Pennsylvania lines west, at approximately the same time, resulted in an increase of 12.37 per cent.

While there has been no definite relation between the rates of pay of engineers, firemen, conductors and trainmen, for a great many years as one class of employees has been increased the other classes were correspondingly increased. The managements of the eastern lines received requests from their engineers and firemen for adjustments of their rates of pay and working conditions while the negotiations were pending with the conductors and trainmen, and settlements were made by these companies with the representatives of their employees very largely in line with the increases granted the conductors and trainmen.

On the Baltimore & Ohio Railroad, effective April 1, 1910, the engineers received increases amounting to 8.03 per cent.; firemen, 9.04 per cent.

Pennsylvania Lines East—Engineers, effective June 1, 12 per cent.; firemen, effective April 1 and June 1, 9.6 per cent.

New York Central & Hudson River—Engineers, effective May 1, 8.93 per cent.; firemen, effective May 1, 9.8 per cent.

Lake Shore & Michigan Southern—Engineers, effective June 1, 8.6 per cent.; firemen, effective May 1, 7 per cent.

Michigan Central—Engineers, effective September 1, 16.4 per cent.; firemen, effective May 1, 16.93 per cent.

Cleveland, Cincinnati, Chicago & St. Louis—Engineers, effective April 1, 11 per cent.; firemen, effective June 1, 5.3 per cent.

At this time, the railroads generally also increased other classes of employees to greater or less extent. For illustration:

On the Baltimore & Ohio all employees receiving less than \$212 per month were increased 6 per cent., effective April 1, 1910.

On the Pennsylvania System all employees receiving less than \$300 per month received an increase of 6 per cent., effective April 1, 1910.

On the New York Central and Boston & Albany all employees receiving less than \$200 per month received an increase of 7 per cent., excepting employees whose wages had been increased January 1, 1910.

With the exceptions of increases granted to certain occupations and in some cases certain classes of service, the rates established in 1910 continued until the engineers arbitration in the year 1912. In January of that year the eastern railroads were presented by the committees representing their engineers

with a request for revision of their wage schedules. The railroads decided to handle the movement collectively; conferences were held and the requests of the engineers were declined. They appealed this decision to the individual engineers who authorized their representatives to call a strike in the event of satisfactory settlement not being reached. After the so-called strike vote was tabulated, conferences were resumed but the railroads refused to recede from their position. Both parties refused to request mediation under the federal law, but the federal mediators intervened of their own volition. Their intervention resulted in arranging for arbitration, by a special board consisting of the Honorable Oscar Straus, chairman; Doctor Charles R. Van Hise, Honorable Frederick Newland Judson, Otto N. Eidlitz, Albert Shaw and Daniel Willard representing the railroad companies, and P. H. Morrissey, representing the employees. Hearings were held from July 15 to 27 inclusive, and the board rendered its decision as of November 2, 1912, effective from May 1, 1912. The railroad parties to this arbitration estimated that the wages of engineers were increased approximately \$1,600,000 or four per cent. The award having been rendered in November, 1912, none of the cost appears in the expenses for the fiscal year ending June 30, 1912, the increase for May and June being taken up in the expenses for the fiscal year ending June 30, 1913. These rates are still in effect for the engineers.

The application of this award to the Baltimore & Ohio cost \$193,925 or 5.16 per cent.

The agreement to arbitrate the engineers questions was executed in New York City on April 30, 1912. On April 29 the president of the brotherhood of locomotive firemen and engineers communicated with the chairman of the conference committee of managers, enclosing a proposition for revision of their schedules and asking whether it would be agreeable to handle the negotiations collectively or individually. The railroad companies decided to handle it collectively. Owing to the pending hearings in the engineers arbitration proceedings negotiations with the firemen had to be deferred. Meetings were held in July and August but they were only of a preliminary nature. Final conferences began on December 3, 1912, and with several intermissions continued until January 16, when, owing to the inability to agree, the firemen adjourned and presented the situation to the employees on each railroad and were authorized to call a strike in the event of satisfactory settlement not being reached. On February 11 conferences were resumed but it still being impossible for the railroads and firemen to agree, both parties joined in request to the federal mediators to intervene. This intervention resulted in arranging for arbitration under the terms of the Erdman Act, the arbitrators selected being the Honorable William L. Chambers, chairman; W. W. Atterbury representing the railroad companies and Albert Phillips representing the employees. The arbitration proceedings began in New York on March 10, terminating on April 5. The decision was rendered April 23, effective from May 3, 1913. Owing to numerous questions arising under this award it has not been applied in its entirety on all railroads, but the conference committee of managers have made a careful estimate of the cost thereof, which is \$2,757,000 per annum or 9.4 per cent., based on operations for the calendar year of 1912. The Baltimore & Ohio has applied the award and careful calculations show the increased cost per annum to be \$295,500 or 10.57 per cent.

While the negotiations with the firemen were in progress, a communication dated December 28, 1912, was addressed to the chairman of the conference committee of managers by the presidents of the Order of Railway Conductors and Brotherhood of Railroad Trainmen, advising that on January 6, 1913, certain wage propositions would be presented by the committees of the two organizations to the representatives of the eastern railroads east of Chicago and north of the Chesapeake & Ohio, and inquiring whether it would be agreeable to the railroads to handle the negotiations collectively or individually. On various dates in the early part of January, 1913, each of the railroads

involved received these requests from their respective committees. The railroad companies decided to handle the negotiations collectively.

On account of the pending arbitration proceedings with the firemen it was impossible to hold conferences until April 22. It developed that it was impossible to reach a settlement, and the representatives of the conductors and trainmen returned to their respective railroads, presenting the situation to the employees and obtained authority to declare a strike in the event of their inability to negotiate satisfactory settlement. Conferences were resumed on July 8, continuing with several intermissions, until July 16, when it was concluded that a settlement could not be reached. A request signed jointly by the chairman of the conference committee of managers and the presidents of the two organizations was whereupon addressed to the President of the United States for the services of the board of mediators and conciliation, as provided in the Newlands Act which had recently been passed, superseding the Erdman Act. Through this intervention an agreement to arbitrate the differences was entered into on July 26, the board selected consisted of the Honorable Seth Low, chairman, Doctor John H. Finley, Messrs. W. W. Atterbury and A. H. Smith, representing the railroad companies, and Messrs. L. E. Sheppard and D. L. Cease representing the employees. The hearings began on September 11 and terminated October 10. The award was rendered November 10, effective from October 1, 1913. Up to this time the award has not been applied, but the arbitrators state in their award that the cost is estimated at \$6,000,000 per annum or 7 per cent. While the management of the Baltimore & Ohio and the representatives of the employees have not, up to this time, had conference for the purpose of revising the schedules to conform to the award, careful estimates have been made of the cost thereof, which indicate that the wages of conductors and trainmen on the railroad will be increased \$578,112 per annum, or 7.55 per cent.

It will be seen from the foregoing that, since and in addition to the wage increases granted in the calendar year 1910, a small portion of which was effective in the fiscal year ending June 30, 1910, the engineers, firemen, conductors and trainmen have been awarded increases through arbitration proceedings amounting to \$10,350,000 per annum on the eastern railroads, and increases in rates of pay have been granted to various other classes of labor amounting to large sums in the aggregate in addition to those granted in the year 1910.

**FREIGHT CARS IN SWEDEN.**—The freight cars of Sweden are of a type similar to those generally used in England and on the continent. Swivel trucks for use on freight cars, however, are unknown in Sweden. Only the light, 4-wheel cars which can be switched in yards by men without car movers, are in use in that country.

**ARGENTINE COURTS PROTECT RAILWAY CLERK.**—That Argentine courts of law intend to maintain and protect the rights of railway property and the life of the employes is exemplified by the recent case where Lieutenant Badie, of the Argentine army, shot Sr. R. Haedo, a ticket agent at Retiro station of the Central Argentine Railway. It appears that in spite of the crowd before the ticket office the lieutenant forced his way to the front and demanded priority of being served, and on Haedo, the ticket agent, refusing to acquiesce, Badie drew his revolver and fatally wounded the man. Badie's defence was on the ground that Haedo's refusal was a direct insult to the Argentine flag. The public prosecutor, however, said the case was without precedent, and he did not see what the flag of the army had to do with the moral duty of an inoffensive clerk; he passed a sentence of three years' imprisonment. Badie appealed to the higher courts, with the result that the sentence has been increased from 3 to 10 years, coupled with an expression of regret that capital punishment was not permissible in the republic.

## General News.

The repair shops of Street's Western Stable Car Line in Chicago were partially destroyed by fire on December 4, with 25 cars.

President Wilson says that he intends to reappoint Interstate Commerce Commissioner Clements, whose term expires at the end of this month.

The United States district attorney at Chicago last week filed 25 suits against six railways, charging violations of the laws regarding the transportation of livestock.

The shops of the Missouri Pacific at Sedalia, Mo., and Little Rock, Ark., and the shops of the Missouri, Kansas & Texas at Sedalia and Parsons have been placed on a 7-hour basis for the winter.

The Chicago, Burlington & Quincy has put in service five new all-steel dining cars built by the Pullman company. These cars are 79 ft. 6 in. long and seat 36 persons. They are lighted by indirect lighting.

Pierce Butler, of St. Paul, Minn., has been selected as a member of the board of arbitration which has been hearing the wage controversy between the Chicago, Burlington & Quincy and its trainmen, to succeed Fairfax Harrison, who resigned on account of his election as president of the Southern.

In New York City, December 13, the Interstate Commerce Commission, represented by Commissioner Prouty, will begin a hearing in its investigation of the complaint of the Postal Telegraph Company that it does not receive fair treatment from the Western Union where messages are interchanged.

The Independent Order of Railroad Employees is the name of an organization which, according to a Reading (Pa.) paper, has been in existence on the Philadelphia & Reading Railway for a year past, and has been the means of getting the wages of employees—principally or wholly telegraphers—raised in an aggregate amount of \$60,000.

The Pennsylvania Railroad, like other roads, has recently reported largely diminished net earnings, and the shops of the company have been put on short time; but, coincident with this announcement, comes the news that the movement of freight over the main line is so heavy that 300 cars a day are diverted at Altoona and sent eastward over the Petersburg cutoff.

An unusually severe snow storm passed over Colorado last week and for several days seriously interfered with traffic of all kinds. In Denver the snowfall was 44 inches. Street cars were abandoned in the drifts and many of the streets were impassable for vehicles of all kinds. Trains from all directions were many hours late and some lines were blocked for days. The storm ceased on Friday.

The House Committee on Interstate and Foreign Commerce held a hearing at Washington last Saturday on bills designed to promote safety on railroads. Mr. Belnap, inspector of the Interstate Commerce Commission, spoke in favor of regulations to limit speeds of trains. Mr. Borland, assistant chief inspector of safety appliances, spoke in favor of the Esch bill, making the block system compulsory.

J. B. Warrington, supervising agent of freight service of the Philadelphia & Reading, testifying at a hearing before the Interstate Commerce Commission in Philadelphia last week, said that his road had plans for making improvements in freight stations in that city, to cost \$1,527,974. Improvements at Front and Chestnut streets will cost \$538,974; at Broad and Callowhill streets, \$268,000; at Willow and Noble streets, a double deck freight house, \$500,000.

C. A. Cook, an usher on the westbound platform of the passenger station of the Pennsylvania Railroad at North Philadelphia, is so efficient and courteous in the discharge of his duties that a passenger who had observed the usher's conduct for two or three years, wrote to the general manager of the road a letter of appreciation and commendation; and the railroad company not only prints the letter, in a pamphlet to be circulated in newspaper offices and elsewhere, but gives with the letter a portrait of Mr. Cook.

The Cleveland, Cincinnati, Chicago & St. Louis announces that the divisional organization which has heretofore prevailed is discontinued and a departmental organization is substituted. The superintendents are relieved from the duty of supervision of the engineering department matters on their respective divisions. In the engineering department, the chief engineer will have charge of all construction and standards of all matters in connection with contractual relations with individuals and corporations and all work heretofore handled by the engineering department except maintenance of way and structures. A chief engineer of maintenance of way will have charge of all matters pertaining to maintenance only, reporting direct to the general manager. Engineers of maintenance of way will report to and receive instructions from the chief engineer of maintenance of way on all matters pertaining to maintenance and to the chief engineer on all other matters pertaining to the engineering department.

The American Institute of Consulting Engineers, Alfred Noble, president, has sent to President Wilson a letter requesting that an able and experienced engineer be appointed to one of the vacancies on the Interstate Commerce Commission. The letter points out the special fitness of an engineer to deal with questions coming before the Commission concerning engineering and railroad operation. The railroad engineer's experience is useful also in dealing with the regulation of rates. The Institute has no candidate and declares that it has no motive except to serve the administration. The President is reminded that an engineer of the type under consideration would not serve in a subordinate capacity, under laymen, while yet he would probably make personal sacrifice for the honor of serving on the commission. The Institute asks not only the appointment of an engineer, but of an engineer with judicial temperament, executive ability, and the other obviously necessary qualifications for such a high office.

Railway traffic in Texas has been seriously affected during the past week by floods in the Brazos and Trinity rivers and high water in many other streams, causing considerable damage to tracks and bridges. On December 3, the Missouri, Kansas & Texas was forced to suspend traffic between Hillsboro and Georgetown, Tex.; the Texas & Pacific had several washouts between Arlington and Handley; the Houston & Texas Central was tied up for a time by a washout 100 miles south of Dallas; the Missouri, Kansas & Texas bridge at Waco was washed out; two miles of the International & Great Northern track was washed out at Maypearl, near Fort Worth, and a long pile trestle near Hearne was swept away. Trains on nearly all roads in the state have been obliged to detour, and service has been very irregular for several days. The floods have extended also to Eastern Oklahoma and Western Arkansas, and swollen streams have done considerable damage in parts of Missouri and Kansas. A St. Louis & San Francisco bridge at Talihina, Ark., was washed away on December 4, and a large part of the false work of the steel bridge being constructed between Forth Smith and Van Buren, Ark., was destroyed by a flood in the Arkansas river on December 5.

### Coroner's Jury Report on Panama Railroad Accident.

The coroner's jury empaneled to investigate the collision on the Panama railroad on November 6 between a passenger train and a work train, which resulted in the death of six persons, has submitted a report placing the responsibility for the collision on the crew of the work train, who are said to have encroached on the right of the passenger train because they "for the moment overlooked its presence, position and movements." The jury recommended that the block system be maintained for the full 24-hour day and that no crews be allowed to work longer at one time than the regular established hours of service, except in cases of emergency.

### Fire Prevention Day on the Rock Island.

Paul Hevener, Assistant Supervisor of the Insurance fund of the Rock Island lines, has announced the results obtained by the observance of Fire Prevention Day. The following circular was sent to all superintendents: "October 9 has again been set aside by the governors of the various states, and the National Fire Protection Association, as Fire Prevention Day. The real purpose of this day is to make a fall cleanup of premises before the setting in of winter. It has been said by eminent authority

that cleanliness is 90 per cent. of fire prevention, and I trust you will circularize this matter among your agents, master mechanics and other subordinate officers, and see if we, on the Rock Island cannot make it a day of general housecleaning."

A report in detail has since been received from all divisions which includes the following as some of the accomplishments of the day's work: Interior of all buildings given a thorough housecleaning; rubbish, grass and all other inflammable material removed from under and around buildings; fire apparatus, hydrants, hose, couplings, etc., carefully examined to insure efficient service in case of emergency; provision made for oil storage and lamp cleaning outside of main buildings, and fresh sand provided; stove pipes and flues inspected and defects remedied; birds' nests removed from eaves of buildings to prevent engine-spark fires; accumulations of old straw, hay, etc., removed from stockyards; metal boxes provided for storage of matches and fuses; "no smoking" signs posted; bunk cars thoroughly cleaned out; open spaces under platforms and buildings boarded up.

#### Form 19 Exclusively.\*

At a casual glance, it would seem that there is a real element of safety in the conductor's signature on a train order and his personal delivery of the order to the engineman; but when the process of transmission and delivery is analyzed, it will be found that the essential factors are (1) correct transmission and repetition, (2) proper display of the train order signal, (3) assurance of delivery.

The first and second factors are alike in all respects up to the delivery of either "31" or "19" orders. Errors of transmission and repetition or failure in display of signal are as likely in one as in the other, and no more likely in one than in the other. It is evident, therefore, that the crux of the whole matter is in assurance of delivery. That this assurance is greater in the delivery of "19" orders is beyond question. In delivering "31" orders the operator simply sees that the signal is displayed and beyond an occasional glance, especially by night, to observe whether it remains displayed, has no further responsibility in the matter until the train stops and the conductor reports for the orders that may be awaiting him or the clearance card which permits him to disregard the signal. The conductor's signature on the order and its transmission to the dispatcher before "complete" can be given are mere formalities. This procedure, to be sure, certifies to the dispatcher that the conductor has received the order, but is no assurance at all until the train has been stopped and evidences nothing more than that the signal has been displayed and seen and its indication obeyed. There remains just as much chance of misunderstanding of the order, forgetfulness of it or misreading of it as before, for the order has undoubtedly been repeated to the dispatcher long before. The standard code does not require the conductor to read the order to the operator or the engineman to read it to the conductor. Apparently that is not considered an essential element of safety, although most roads so regard it. Is it, in reality? More than one case of careless reading by enginemen and consequent disaster has been occasioned by perfunctory reading by conductors and dependence by the engineman on the evidence of his ears instead of also his eyes.

In the delivery of "19" orders all this is changed and, in our opinion, greatly in the interest of safety. The operator becomes an active instead of a passive agent in the transaction. On him now rests the responsibility of actual delivery. He is on the qui vive for the approach of the train for which he holds orders. He is out on the platform to deliver them to it. If the train order signal is not properly displayed, he notices it and uses hand signals. The chance that the train will run past the station without the orders is much less, and if either engineman or conductor fails to catch them the train must stop, back up if necessary, and obtain them before proceeding. Once obtained, each must read for himself. This done, the orders will be as certainly obeyed as if they had been delivered under the "31" procedure. Furthermore, to insure that they—all of them, if any—will be delivered, the operator must, before arrival of the train, repeat from the clearance card which invariably accompanies orders, or should accompany them, their several numbers to the dispatcher, who checks these numbers with his office record and whose O. K. is necessary to make the clearance card valid. In our opinion, assurance of delivery of train orders is

the chief thing to be sought for. Upon that depends safety in train despatching more than upon any other factor. The "19" order, we believe, assures delivery more certainly than the "31." It does not lessen the work or the responsibility of the train despatcher, and train despatchers advocate it not for that reason, but because their experience has led them to believe that it is superior to the "31" in safety and immensely more effective in moving traffic.

#### Grashof Medal Presented to George Westinghouse.

The ceremony of presenting the Grashof medal to George Westinghouse took place at the annual convention of the American Society of Mechanical Engineers on Wednesday evening, December 3. Unfortunately Mr. Westinghouse was unable to be present, and Dr. Goss, the president of the society, turned the medal over to Mr. Hartness, the president-elect, to be delivered to Mr. Westinghouse. The Verein Deutscher Ingenieure was represented by Geheimrath Romberg, G. D. Waetzoldt, Rudolph Herring, Henry Hess and Col. E. D. Meiers.

Mr. Westinghouse is the first American to receive this medal. It was founded by the Verein Deutscher Ingenieure of Germany in memory of Franz Grashof and is given by the Union only on recommendation of the council, and by unanimous vote in open general meeting, to men who have rendered pre-eminent service in the field of engineering, either in research or in practical activity. It is the highest honor in the gift of the engineering profession of Germany. The actual award of the medal to Mr. Westinghouse was made at the fifty-fourth annual meeting of the Verein Deutscher Ingenieure in Leipzig, Germany, June 23, 1913, officers and members of the American Society of Mechanical Engineers being present. In making the presentation Dr. Oskar von Miller, president of the Union, said:

"The distinction conferred by the largest scientific and technical society in the world is not a thing that is given away on a festive occasion, nor one to serve as a mark of attention and courtesy; it can be won only by actual services for the good of humanity. Engineers will have no doubt that George Westinghouse, whose name is so well known throughout the world, does deserve this distinction."

#### Chicago Terminal Discussion.

Negotiations regarding the conditions to be included in ordinances providing for the construction of a Union station in Chicago for the Pennsylvania Lines, the Chicago, Burlington & Quincy, and the Chicago, Milwaukee & St. Paul, have been in progress through the past week before a sub-committee of the city council committee on railway terminals, Engineers J. F. Wallace and Bion J. Arnold, and representatives of the Chicago plan commission, and the citizens' terminal committee. The Union Station Company has been represented by Attorney Robert Redfield. The engineers have been gradually reconciling various divergent views expressed in their original reports, and the negotiations are now in a stage of making concessions for the purpose of reaching a common ground for the railways in the city. On December 5, following a meeting of the executive officers of the roads, Attorney Redfield presented a list of concessions which the roads will agree to make, including co-operation with the city in the construction of several viaducts and other street improvements, and co-operation with the city in the establishment of a permanent expert commission on terminals, if provided for by a separate ordinance; and payment of full compensation to the city for all streets vacated. The Burlington also promised to co-operate with the city in the straightening of the Chicago river. It was brought out that the Chicago & Alton, which uses the present Union station, is not a party to the plan for a new station. An effort was made to secure an agreement by the roads to abandon the station at Jackson boulevard when its capacity is outgrown, and to move south to Twelfth street, but Attorney Redfield has asserted that the roads will not make such an agreement.

#### Texas Public Sentiment More Friendly.

J. H. Hill, president of the General Managers' Association of Texas, in his annual report to the association, presented at a meeting at Dallas on December 5, discussed the public relations of the railways in Texas as follows:

"To my mind the greatest asset the association has to its

\*Editorial from the *Train Dispatchers' Bulletin*.

credit is the success which has followed its endeavors to bring about a better understanding and a more friendly feeling between the railroads and the people.

"It has in a dignified and businesslike manner, by personal efforts of its members and through the medium of the press (the latter misunderstood at first by a few, but now understood by nearly all), sought to place before the public such statements and facts as would enable the people to fully understand the true relation between them and the railroads.

"This policy has been followed for two reasons. The first and main one is that the people pay all the expenses, damages, taxes, etc., pertaining to the operation of the railroads, and are therefore entitled, as a matter of right, to know why these expenses are and how they affect them, in order that they, the people, may, in the exercise of their just and legal rights, have an opportunity to oppose the creation of additional and unnecessary expenses which the public would have to pay. Second, because a very small and insignificant percentage of the people of this country have, in the past, for their own personal gain and advancement sought to engender feelings of prejudice and ill-will toward the railroads by resorting to abuse and misrepresentation. Such misrepresentations, though in many instances ridiculous, when not denied or refuted, have been accepted by many honest and fair-minded people as true.

"This policy of taking the public into our confidence and treating it as it deserves to be treated has occasioned some expense; but for every dollar so expended, hundreds of dollars have been saved in expenses which would have been saddled upon the people but for such efforts. The people, therefore, have been benefited.

"Hundreds of letters received and the expressions in the editorials of a fearless press are convincing that our present practice of dealing openly and fairly with the people meets with their hearty approval. In fact, but two adverse criticisms appeared in the press throughout the entire state, both of which were promptly and effectively answered. It can be truthfully said that the great and overwhelming majority of the people of Texas desire to be fair to the railroads, and will be if honestly informed.

"At the present time it is the policy of the association to continue to give public expression, when considered necessary, to any and all questions upon which the joint welfare of the people and the railroads depend, inviting honest inquiry and criticism, and at no time to base statements upon statistical figures that cannot be proven by the public records of the railroad commission and other public offices of the state.

"That the sentiment of the people of the state toward the railroads has changed decidedly for the better, due in no small degree to the fair and honest expressions of the press and the information given to the people through the channels of publicity referred to above, is patent to all, and a continuance of such policy is, to my mind, not only proper but desired by the public.

"No agreement has been entered into nor action taken upon any subject by the association since its organization that is in conflict with the organic or statutory laws of the state."

#### Mr. Acworth's Observations in America.

W. M. Acworth, the English railroad economist, who has just gone home after a two months' stay in this country, spoke to a reporter of the *New York Times* concerning business conditions here; and his words are reported in substance as follows: Refusal of the freight rate increase which the eastern railroads are now asking would cause much concern to European holders of American securities. The railroads have made out a very strong case in favor of the proposed 5 per cent. increase. The Interstate Commerce Commission seems more desirous of being entirely fair, although it is perhaps handicapped by popular opposition to allowing the railroads a higher level of rates.

It seemed to Mr. Acworth that the commission had gone somewhat beyond the lines imposed upon it by Congress. It is not incumbent on the commission to suspend proposed increases in rates practically as a matter of course; it should only resort to this power when some special reason appears for believing a proposed change in rates to be unreasonable. In actual practice, he thought, a proposed increase in rates by the railroads had become little else than an application by the railroads to the commission for permission to change their tariffs. He did not believe that the law was intended to work just in that manner.

Mr. Acworth gave praise to the manner in which American railroads as a whole were being managed, and expressed surprise that railroad men did not stand up for themselves and for their property with a little more vigor.

"American railroad men are not managing their properties like fools; and yet they have in effect allowed themselves to be called both fools and knaves. It seems strange that there are no railroad men doing for themselves what Mr. Vanderlip has done for Wall street. He expressed himself outspokenly in defense of the financial community and its institutions and refused to allow himself to be branded as an undesirable citizen merely because he was the head of a great financial institution. Railroad men are in an excellent position to make the same sort of stand for themselves, and it seems to me that they most certainly should do so. I can understand why they feel it is useless to fight against the enactment of additional regulatory legislation, but it is an altogether different matter to defend themselves against what seems to me to be the entirely unwarranted charge that the railroads as a whole are being inefficiently and dishonestly managed."

Of the two methods of providing necessary improvements and extensions—the return to the property of surplus earnings and the investment of additional capital—only the latter, Mr. Acworth said, was open to most roads.

Mr. Acworth said he saw no good reason for assuming that in the long run the railroads of the United States could escape a very large increase in their capitalization. Mr. Acworth thought that \$15,000 a mile was a liberal estimate of the cost of right-of-way on English railroads. The cost of this item here is, of course, much lower, but this is about the only advantage in the matter of cost, which Mr. Acworth found in a comparison between English railroads and those of the United States. Materials here were no cheaper, and certainly labor was not.

The railroads of this country are suffering for the sins of a past generation. It is neither fair nor expedient to impose upon the railroads of today the penalty for offenses committed in the past. . . . If the railroads are not permitted to go on with their development work sooner or later a railroad blockade will be encountered which will be very much worse than any ever experienced in the past.

On the subject of government ownership of railroads, Mr. Acworth said he felt sure that government ownership would not come about if only the subject were sufficiently discussed in advance. All that was needed, he thought, to prevent a resort to this expedient was free and intelligent public discussion of the proposal.

#### 140,000 Private Cars.

The Interstate Commerce Commission has completed its investigation into ownership of freight cars in the United States, and now for the first time definite figures have been gathered as to the number and character of freight equipment of American railroads.

According to the commission's figures there are in the United States 2,300,000 freight cars owned by the railroads and 140,000 cars owned by car companies or other private ownerships. Private parties own more refrigerator cars than the railroads, the private car lines owning 54,000 and the railroads 49,000.

The investigation developed that there are 43,000 freight cars in the United States built specially for the transportation of automobiles.

Early in January the Commission will hold a hearing in Chicago in connection with its investigation of alleged abuses in connection with private cars.

#### Train Auditors on the M. K. & T.\*

The following figures seem to demonstrate the wisdom of our management in inaugurating and maintaining the train auditor system.

In 1903, cash fares paid on trains amounted to \$143,361, or 2.934 per cent. of passenger earnings. If we apply the same per cent. to the ticket sales in 1913, it would mean a total of cash

\*From a paper by W. S. St. George, General Passenger and Ticket Agent of the Missouri, Kansas & Texas, read at the annual meeting of the General Passenger Agents' Association at Philadelphia.



fare collections for that year of \$261,780; but, as a matter of fact, the total of our cash fare collections for the fiscal year ending June 30, 1913, was \$464,949, so that after deducting salaries of 89 auditors and other expenses amounting to \$130,098, we have still a balance of \$73,070 over and above what the collections would have been had the same relative differences existed between cash fares and passenger earnings during the time this feature of our business was handled by conductors. I do not mean to convey the impression that our conductors are dishonest or fail to make correct returns of the cash fare collected. . . . On some of our trains, it would be utterly impossible for any conductor to perform the dual service in a satisfactory manner, and in relieving him of the responsibility of ticket collections we have not only obtained additional revenue from this source but have added to passenger receipts by increasing the efficiency, regularity and popularity of our service.

There is also another feature which should be considered in this connection, and that is, the remarkable freedom we have enjoyed from accidents and damage claims resulting therefrom. During the ten years in which our conductors have been relieved from the collection of fares and have devoted their entire time to the operation of trains, we have only had one death caused by a collision between our own trains, and one of the trains involved in this wreck was without an auditor.—G. P. & T. A. M. K. & T.

#### Quotations from the Wise Men.

"Efficiency" is the title of a little pamphlet of 21 pages, 3¼ in. by 6½ in., which has been issued by W. F. Andrews, general superintendent of transportation of the Queen & Crescent Route (the Cincinnati, New Orleans & Texas Pacific, and the Alabama Great Southern), and as it is marked "No. 1, Volume 1" we assume that the intention is to issue a periodical. While the lectures and admonitions in this pamphlet are addressed to the employees of the roads named and deal with concrete problems, many of which would not be particularly instructive to persons on other roads, it is notable among works of its kind by reason of its distinctive style of composition, and because of the inclusion of much good didactic matter which is applicable not only on other roads but in all walks of life; and sprinkled through the book are quotations from well known philosophers—Ruskin, James Russell Lowell, Thackeray, Phillips Brooks, George Eliot, J. G. Holland, and others.

Following is a sample page, page 3:

*Efficiency—Its Meaning.*—It means that by conscientious effort we can improve our labor so the result will be self satisfying, thereby making our tasks seem lighter and our lives brighter.

It means less labor to accomplish the same result.

It means that a little efficiency practiced by each one of us will combine to the good of all of us.

"Thank God every morning when you get up that you have something to do that day which must be done, whether you like it or not. Being forced to work, and forced to do your best, will breed in you a hundred virtues which the idle never knew."—Chas. Kingsley.

*Efficiency—Qualification Necessary.*—To be efficient we must first improve ourselves in accordance with our ability, and as this improvement develops, our capacity for being efficient will develop—therefore the first fruits of efficiency is OUR OWN WORTH INCREASED.

We must be loyal to the organization which employs us, believe in the righteousness of its cause and in its ultimate success, and aim to that end.

Every day we see men of energy whose efforts bring small results. We see men with good qualifications, loyal to a cause and willing to work, but who plod along seemingly unseeing and unthinking, because they have not aimed their energies toward a definite end. They perform as much labor as the efficient man but do not succeed because of their failure to be steadfast in their purpose.

Seven pages are given up to the one subject of courtesy; and the subject is treated from such a variety of standpoints that one naturally questions whether it will not be necessary to have something in the shape of a test or examination in order to learn to what extent employees read the detailed statements; to find out how far the hoped-for results actually materialize. Ticket agents and conductors are appealed to in the following very direct manner:

When a passenger has paid for his ticket, do not throw his change at him in "don't care" sort of a manner; remember to use the expression that is like oil, the "THANK YOU" in kindly tone. A few kind words in a courteous tone will make friends and cost you nothing.

Try it and you will feel better when the day's work is done.

"Kindness—a language which the dumb can speak and the deaf can understand."

A passenger conductor employed on a well-known railroad was known for his courteousness and good nature. He made it a practice when entering the car where perhaps several tired, anxious or discouraged travelers were gathered together, with a hearty "Good Evening, Gentlemen, I'll take your tickets, if you please," and as each ticket was handed him he invariably said "Thank You" in a tone so pleasant that the man in the corner who was about to complain that the train was running too fast or too slow, or making too many or not enough stops, forgot his troubles and fell under the spell of this man's good humor. Very rarely will complaints be made or thought of under these conditions.

#### Inadequate Pay for Postal Cars.

With reference to statements in the press that the post office committee of the House of Representatives was considering a question that the government own railway postoffice cars instead of paying "rental" to the railroads for their use, Ralph Peters, president of the Long Island and chairman of the Committee on Railway Mail Pay, makes the following statement:

"The government pays the railroads \$4,882,000 as annual rental for 1,353 cars, or about \$3,400 per car. The steel postal car, with which all railroads must be equipped by 1915, costs about \$12,000.

"Postal car pay, which is about 10 per cent. of the total amount paid the railroads for transporting the mails is supplementary pay to make up for the fact that postal cars 60 ft. or 70 ft. in length do not carry sufficient mail to reimburse the railroad company merely for the weight of mail carried. About 75 per cent. of the space in these cars is occupied by pigeon-hole cases and sorting racks.

"Postal cars do not carry all the mail. For the distributing space used in combination baggage cars the government pays absolutely nothing unless they are of 40 ft. or more in length. The weight of mail carried in such compartments is very small, and therefore the major service performed by the railroads is in carrying distributing space. The aggregate space now carried in this manner in 4,029 such cars amounts to 92,866 linear feet, equal to the length of 1,548 full 60-ft. postal cars. Yet for this distributing space in compartment cars the government makes no payment, except for the small amount of dead weight of the mail.

"The payment for postoffice cars, including the pay for weight carried, is about 19 cents for each mile a 60 ft. car runs, whereas all other service on passenger trains pays an average of 26 cents for each mile a car is run. If the supplementary pay for the full postal cars were eliminated, the railroads would only receive about 17 cents a mile for carrying the mail as compared with 26 cents from other passenger service.

"The cost of maintaining and operating a moving postoffice, with its light, heat and fixtures; carrying the necessary clerks and assuming all risks attendant thereto, constitute an annual sum fairly to be compared with the original cost of a car.

"I have no comment to make upon the suggestion that the government should own its own railway postoffice cars, but such a plan cannot be favored fairly upon any plea that the railroads are now overpaid for this portion of the mail service. In fact the railroad officers of the United States feel that the companies are today underpaid by at least \$15,000,000 for their service in carrying the mails.

"Persons interested in this subject might well read a published letter from Postmaster General Frank H. Hitchcock, dated and addressed to Hon. John W. Weeks, chairman of Committee on Post Office of the House of Representatives."

#### New Haven Directors Pass Dividend.

The directors of the New York, New Haven & Hartford, at their meeting in New York City, December 10, voted to declare no dividend, the first action of the kind in the history of this company for forty years or more. In an explanatory statement Chairman Elliott said:

"The New Haven is a strong company, owning valuable property, real estate and securities worth many millions of dollars. Some of this real estate and the property represented by the securities and the securities themselves can in time be marketed, and thus strengthen the cash resources of the company. It is very difficult to sell property and securities at this time, and the directors believe it is unwise to attempt to do so until general conditions are better.

"During the calendar year 1913 the road has already paid dividends of 5 per cent., amounting to \$8,657,361.50. For the four months ending October 31, the income available is \$3,390,000. Estimating November and December there is a possible total income for six months of \$3,890,000. Deducting from this the 1½ per cent. dividend, \$2,356,768, paid on September 30, leaves \$1,533,231, all of which is required for working capital.

"The company is now entering upon those months where the volume of business is apt, under normal conditions, to be less than during the months July to November inclusive. The arbitration of wage disputes in the last eighteen months has resulted in increases in pay that will increase expenses for the present fiscal year between \$800,000 and \$1,000,000 for the same number of employees. The improvements to which the company is already committed, in the interest of safety, efficiency and greater convenience to the public, will take large sums of money. There are important lawsuits and investigations pending, the results of which are uncertain in their effect upon the general financial and corporate condition of the property.

"The directors feel, therefore, that the welfare of the company, of the stockholders, and of the territory served by the various lines will be conserved better under all the conditions now confronting the company by not declaring at this time a dividend."

#### American Electric Railway Association and American Electric Railway Manufacturers' Association.

The midyear meeting of the American Electric Railway Association will be held at the Engineers' Society Building, New York, on January 29, 30 and 31. The annual dinner will be held at the Waldorf-Astoria on the evening of Thursday, January 29. There will be a change in the arrangements this year in accordance with the resolutions of the executive committee passed at its meeting in Atlantic City, in that, instead of being a complimentary affair the dinner will be one where each may pay his own way. Any subscriber may invite as many guests as he wishes. The program of the speakers is now being prepared and will be announced later.

#### American Railway Safety Association.

The American Railway Safety Association has called a meeting to be held at the Manhattan Hotel, New York City, on December 13.

#### MEETINGS AND CONVENTIONS.

*The following list gives names of secretaries, dates of next or regular meetings, and places of meeting.*

- AIR BRAKE ASSOCIATION.—F. M. Nellis, 53 State St., Boston, Mass. Next convention, May, 1914.
- AMERICAN ASSOCIATION OF DEMURRAGE OFFICERS.—A. G. Thomason, Boston, Mass. Convention, May 19, 1914, St. Louis.
- AMERICAN ASSOCIATION OF GENERAL PASSENGER AND TICKET AGENTS.—W. C. Hope, New York.
- AMERICAN ASSOCIATION OF FREIGHT AGENTS.—R. O. Wells, East St. Louis, Ill. Next convention, April 21, Houston, Tex.
- AMERICAN ASSOCIATION OF RAILROAD SUPERINTENDENTS.—E. H. Harman, St. Louis, Mo.; 3d Thursday and Friday in May.
- AMERICAN ELECTRIC RAILWAY ASSOCIATION.—E. B. Burritt, 29 W. 39th St., New York. Mid-year conference, New York, January 29, 30, 31.
- AMERICAN ELECTRIC RAILWAY MANUFACTURERS' ASSOC.—H. G. McConaughy, 165 Broadway, New York. Meetings with Am. Elec. Ry. Assoc.
- AMERICAN RAILWAY ASSOCIATION.—W. F. Allen, 75 Church St., New York.
- AMERICAN RAILWAY BRIDGE AND BUILDING ASSOCIATION.—C. A. Lichty, C. & N. W., Chicago. Next convention, October 20-22, 1914, Los Angeles, Cal.
- AMERICAN RAILWAY ENGINEERING ASSOCIATION.—E. H. Fritch, 900 S. Michigan Ave., Chicago. Next convention, March 17-20, Chicago.
- AMERICAN RAILWAY MASTER MECHANICS' ASSOCIATION.—J. W. Taylor, Karpen building, Chicago. June 15-17, Atlantic City, N. J.
- AMERICAN RAILWAY TOOL FOREMEN'S ASSOCIATION.—A. R. Davis, Central of Georgia, Macon, Ga.
- AMERICAN SOCIETY FOR TESTING MATERIALS.—Prof. E. Marburg, University of Pennsylvania, Philadelphia, Pa.
- AMERICAN SOCIETY OF CIVIL ENGINEERS.—C. W. Hunt, 220 West 57th St., New York; 1st and 3d Wed., except June and August, New York.
- AMERICAN SOCIETY OF ENGINEERING CONTRACTORS.—J. R. Wenlinger, 11 Broadway, New York; 2d Tuesday of each month, New York.
- AMERICAN SOCIETY OF MECHANICAL ENGINEERS.—Calvin W. Rice, 29 W. 39th St., New York.
- AMERICAN WOOD PRESERVERS' ASSOCIATION.—F. J. Angier, B. & O., Baltimore, Md. Next convention, January 20-22, 1914, New Orleans, La.
- ASSOCIATION OF AMERICAN RAILWAY ACCOUNTING OFFICERS.—C. G. Phillips, Highland Park, Ill. Annual meeting, June 24, Minneapolis, Minn.
- ASSOCIATION OF RAILWAY CLAIM AGENTS.—C. W. Egan, B. & O., Baltimore, Md. Next convention, May, 1914, St. Paul, Minn.
- ASSOCIATION OF RAILWAY ELECTRICAL ENGINEERS.—Jos. A. Andreucetti, C. & N. W. Ry., Chicago.
- ASSOCIATION OF RAILWAY TELEGRAPH SUPERINTENDENTS.—P. W. Drew, 112 West Adams St., Chicago. Next convention, May 20-23, New Orleans, La.
- ASSOCIATION OF TRANSPORTATION AND CAR ACCOUNTING OFFICERS.—G. P. Conard, 75 Church St., New York.
- ASSOCIATION OF WATER LINE ACCOUNTING OFFICERS.—W. R. Evans, Chamber of Commerce, Buffalo, N. Y.
- BRIDGE AND BUILDING SUPPLY MEN'S ASSOCIATION.—L. D. Mitchell, Detroit Graphite Co., Detroit, Mich. Meeting with American Railway Bridge and Building Association.
- CANADIAN RAILWAY CLUB.—James Powell, Grand Trunk Ry., Montreal, Que.; 2d Tuesday in month, except June, July and August, Montreal.
- CANADIAN SOCIETY OF CIVIL ENGINEERS.—Clement H. McLeod, 413 Dorchester St., Montreal, Que.; Thursday, Montreal.
- CAR FOREMEN'S ASSOCIATION OF CHICAGO.—Aaron Kline, 841 North 50th Court, Chicago; 2d Monday in month, Chicago.
- CENTRAL RAILWAY CLUB.—H. D. Vought, 95 Liberty St., New York; 2d Thurs. in Jan. and 2d Fri. in March, May, Sept., Nov., Buffalo, N. Y.
- CIVIL ENGINEERS' SOCIETY OF ST. PAUL.—L. S. Pomeroy, Old State Capitol building, St. Paul, Minn.; 2d Monday, except June, July, August and September, St. Paul.
- ENGINEERS' SOCIETY OF PENNSYLVANIA.—E. R. Dasher, Box 704, Harrisburg, Pa.; 1st Monday after second Saturday, Harrisburg, Pa.
- ENGINEERS' SOCIETY OF WESTERN PENNSYLVANIA.—E. K. Hiles, Oliver building, Pittsburgh; 1st and 3d Tuesday, Pittsburgh, Pa.
- FREIGHT CLAIM ASSOCIATION.—Warren P. Taylor, Richmond, Va. Next convention, May 20-22, Galveston, Tex.
- GENERAL SUPERINTENDENTS' ASSOCIATION OF CHICAGO.—E. S. Koller, 226 W. Adams St., Chicago; Wed. preceding 3d Thurs., Chicago.
- INTERNATIONAL RAILWAY CONGRESS.—Executive Committee, 11, rue de Louvain, Brussels, Belgium. Convention, 1915, Berlin.
- INTERNATIONAL RAILWAY FUEL ASSOCIATION.—C. G. Hall, 922 McCormick building, Chicago. Annual convention, May 18-22, Chicago.
- INTERNATIONAL RAILWAY GENERAL FOREMEN'S ASSOCIATION.—Wm. Hall, 829 West Broadway, Winona, Minn. Next convention, July, Chicago.
- INTERNATIONAL RAILROAD MASTER BLACKSMITHS' ASSOCIATION.—A. L. Woodworth, Lima, Ohio. Next convention, third Tuesday in August.
- MAINTENANCE OF WAY & MASTER PAINTERS' ASSOCIATION OF THE UNITED STATES AND CANADA.—T. I. Goodwin, C. R. I. & P., Eldon, Mo. Next convention, November 17-19, 1914, Detroit, Mich.
- MASTER BOILER MAKERS' ASSOCIATION.—Harry D. Vought, 95 Liberty St., New York.
- MASTER CAR BUILDERS' ASSOCIATION.—J. W. Taylor, Karpen building, Chicago. June 10-12, Atlantic City, N. J.
- MASTER CAR & LOCOMOTIVE PAINTERS' ASSOC. OF U. S. AND CANADA.—A. P. Dane, B. & M., Reading, Mass.
- NATIONAL RAILWAY APPLIANCE ASSOC.—Bruce V. Crandall, 537 So. Dearborn St., Chicago. Meetings with Am. Ry. Eng. Assoc.
- NEW ENGLAND RAILROAD CLUB.—W. E. Cade, Jr., 683 Atlantic Ave., Boston, Mass; 2d Tuesday in month, except June, July, Aug. and Sept., Boston.
- NEW YORK RAILROAD CLUB.—H. D. Vought, 95 Liberty St., New York; 3rd Friday in month, except June, July and August, New York.
- NORTHERN RAILROAD CLUB.—C. L. Kennedy, C. M. & St. P., Duluth, Minn.; 4th Saturday, Duluth.
- PEORIA ASSOCIATION OF RAILROAD OFFICERS.—M. W. Rotchford, Union Station, Peoria; 2d Thursday.
- RAILROAD CLUB OF KANSAS CITY.—C. Manlove, 1008 Walnut St., Kansas City, Mo.; 3d Friday in month, Kansas City.
- RAILWAY BUSINESS ASSOCIATION.—Frank W. Noxon, 30 Church St., New York.
- RAILWAY CLUB OF PITTSBURGH.—J. B. Anderson, Penna. R. R., Pittsburgh, Pa.; 4th Friday in month, except June, July and August, Pittsburgh.
- RAILWAY ELECTRICAL SUPPLY MANUFACTURERS' ASSOC.—J. Scribner, 1021 Monadnock Block, Chicago. Meetings with Assoc. Ry. Elec. Engrs.
- RAILWAY FIRE PROTECTION ASSOCIATION.—C. B. Edwards, Mobile & Ohio, Mobile, Ala.
- RAILWAY GARDENING ASSOCIATION.—J. S. Butterfield, Lee's Summit, Mo.
- RAILWAY DEVELOPMENT ASSOCIATION.—W. Nicholson, Kansas City Southern, Kansas City, Mo.
- RAILWAY SIGNAL ASSOCIATION.—C. C. Rosenberg, Bethlehem, Pa.
- RAILWAY STOREKEEPERS' ASSOCIATION.—J. P. Murphy, Box C, Collinwood, Ohio.
- RAILWAY SUPPLY MANUFACTURERS' ASSOC.—J. D. Conway, 2135 Oliver bldg., Pittsburgh, Pa. Meetings with M. M. and M. C. B. Assocs.
- RAILWAY TEL. & TEL. APPLIANCE ASSOC.—W. E. Harkness, 284 Pearl St., New York. Meetings with Assoc. of Ry. Teleg. Sups.
- RICHMOND RAILROAD CLUB.—F. O. Robinson, Richmond, Va.; 2d Monday, except June, July and August.
- ROADMASTERS' AND MAINTENANCE OF WAY ASSOCIATION.—L. C. Ryan, C. & N. W., Sterling, Ill. Next convention, September 8-10, 1914, Chicago.
- ST. LOUIS RAILWAY CLUB.—B. W. Frauenthal, Union Station, St. Louis, Mo.; 2d Friday in month, except June, July and Aug., St. Louis.
- SIGNAL APPLIANCE ASSOCIATION.—F. W. Edmonds, 3868 Park Ave., New York. Meeting with annual convention Railway Signal Association.
- SOCIETY OF RAILWAY FINANCIAL OFFICERS.—C. Nyquist, La Salle St. Station, Chicago.
- SOUTHERN ASSOCIATION OF CAR SERVICE OFFICERS.—E. W. Sandwich, A. & W. P. Ry., Montgomery, Ala.
- SOUTHERN & SOUTHWESTERN RAILWAY CLUB.—A. J. Merrill, Grant bldg., Atlanta, Ga.; 3d Thurs., Jan., March, May, July, Sept., Nov., Atlanta.
- TOLEDO TRANSPORTATION CLUB.—J. G. Macomber, Woolson Spice Co., Toledo, Ohio; 1st Saturday, Toledo.
- TRACK SUPPLY ASSOCIATION.—W. C. Kidd, Ramapo Iron Works, Hillsburn, N. Y. Meetings with Roadmasters' and Maintenance of Way Association.
- TRAFFIC CLUB OF CHICAGO.—W. H. Wharton, La Salle Hotel, Chicago.
- TRAFFIC CLUB OF NEW YORK.—C. A. Swope, 290 Broadway, New York; last Tuesday in month, except June, July and August, New York.
- TRAFFIC CLUB OF PITTSBURGH.—D. L. Wells, Erie, Pittsburgh, Pa.; meetings monthly, Pittsburgh.
- TRAFFIC CLUB OF ST. LOUIS.—A. F. Versen, Mercantile Library building, St. Louis, Mo. Annual meeting in November. Noonday meetings October to May.
- TRAIN DISPATCHERS' ASSOCIATION OF AMERICA.—J. F. Mackie, 7122 Stewart Ave., Chicago. Next convention, June 16, Jacksonville, Fla.
- TRANSPORTATION CLUB OF BUFFALO.—J. M. Sells, Buffalo; first Saturday after first Wednesday.
- TRANSPORTATION CLUB OF DETROIT.—W. R. Hurley, L. S. & M. S., Detroit, Mich.; meetings monthly.
- TRAVELING ENGINEERS' ASSOCIATION.—W. O. Thompson, N. Y. C. & H. R., East Buffalo, N. Y. Next meeting, Chicago.
- UTAH SOCIETY OF ENGINEERS.—Fred D. Ulmer, Oregon Short Line, Salt Lake City, Utah; 3rd Friday of each month, except July and August.
- WESTERN CANADA RAILWAY CLUB.—W. H. Rosevear, P. O. Box 1707, Winnipeg, Man.; 2d Monday, except June, July and August, Winnipeg.
- WESTERN RAILWAY CLUB.—J. W. Taylor, Karpen building, Chicago; 3d Tuesday of each month, except June, July and August.
- WESTERN SOCIETY OF ENGINEERS.—J. H. Warder, 1735 Monadnock Block, Chicago; 1st Monday in month, except July and August, Chicago.

## Traffic News.

The New York State canals were closed on the night of November 30, about 15 days later than usual. The Erie Canal was open 170 days.

The Traffic Club of St. Louis has adopted resolutions favoring the proposed 5 per cent. advance in freight rates in Official Classification territory.

The Chicago & Eastern Illinois on December 7 re-established the Dixie Limited train, which will be run between Chicago and Florida during the winter season.

The New York Produce Exchange has complained to the Interstate Commerce Commission that rates on grain from Lake Erie ports to New York are unduly high, giving an unfair advantage to Montreal.

The Boston & Maine has notified its freight agents in the state of Maine that shippers of liquors must sign a statement that the consignment is not to be received, sold or possessed in violation of state or federal laws.

The Copper Range Railroad has opened an extension, four miles long, southward from the present southern terminus of its Painesdale branch to a point near Toivola, Mich., passing through South Range, Baltic, and Trimountain.

At a meeting of the Western Passenger Association last week it was decided to offer the same rates for summer tourist fares next year as have been in effect the past season. The retiring members of the executive committee of the association were re-elected.

The New York, New Haven & Hartford has given up its option on 36,000 acres of lands in Washington county, Maine, which was taken in 1911. It had been the intention of the road, through its industrial department, to conduct agricultural demonstrations on a large scale.

Grain shipments through New Orleans continue exceedingly heavy. The elevators of the Illinois Central and the Texas & Pacific are kept very busy. Combined railroad and ocean rates on grain now favor shipments through New Orleans as compared with Atlantic seaboard ports.

The United States District Court has sustained the order of the Alabama Railroad Commission, requiring the adoption of 2½ cents a mile as the rate for passenger fares on the South & North Alabama, the change to go into effect January 1 next. This road is that part of the Louisville & Nashville between Decatur and Montgomery, 182 miles.

The Pennsylvania Railroad's agricultural demonstration train, consisting of four cars, recently arrived in Philadelphia after making trips over the lines of the company, covering about five months. At most of the towns visited the car was stopped for two days. One car contains displays of fruits and vegetables, another has a complete dairy exhibit, and a third is a milk car, 75 ft. long. The fourth car of the train is a model stock car. Men from the department of agriculture are in charge of the exhibits.

George F. Moore, president of the Manufacturers' Railway, St. Louis, says that under the recent decision of the Supreme Court in the "tap line" cases, his company expects to restore its old tariffs under which the railroads entering the city absorb the charges of the Manufacturers' road. The Chicago, Peoria & St. Louis and the St. Louis Southwestern have already filed tariffs restoring the allowances formerly made to the Manufacturers' Railway. These tariffs were filed December 7, to go into effect January 7.

Ex-President W. H. Taft, as attorney for the trustees of the Cincinnati Southern, and as referee in the controversy in which Cincinnati shippers charged that the Cincinnati, New Orleans & Texas Pacific is discriminating against the city in freight rates over the road, extending from Cincinnati to Chattanooga, Tenn., which was leased by the city to the C. N. O. & T. P., has rendered a decision that the complainants have not made out a case strong enough to warrant the trustees taking action against

the lessees. Attorneys for both sides had agreed to abide by his decision. The Cincinnati shippers have been fighting for a reduction of the rates to Chattanooga and the southeast for 22 years, and the case has been twice before the Interstate Commerce Commission, once before the Commerce Court and twice before the Supreme Court. The commission ordered a reduction of the rates in 1894, but the Supreme Court held it was without power to establish rates. Later the commission ordered a slight reduction, which did not satisfy the shippers.

E. C. Hoag has been appointed supervisor of farm marketing of the St. Louis & San Francisco and will be in charge of a new branch of the company's department of development. W. B. Biddle, chief traffic officer of the Frisco, has outlined the purposes of the new work as follows: "We expect farm marketing to be one of the important features of the work of the department of development. We do not expect to revolutionize the present system of marketing in a day, but investigations covering a period of more than a year convince us that a decided improvement can be made in the interest of both producer and buyer. A great many markets heretofore unsupplied or insufficiently supplied will consume a great share of the products for which the farmers along our lines have not so far been able to find a market. We have also satisfied ourselves that along our own rails markets for a great share of the products produced by the farmers in our territory can be found. There should be a larger interchange of business between various sections along our lines. Bringing this about will result in improved markets for our producers. One of the evils which has resulted in great loss to the producers has been improper grading and packing. The department of development has given its attention for the greater part of the past year to the formation of such grading and packing organizations as would establish a standard for the various products. This we believe will not only enable the producers to better and more profitably sell their output, but will assure the buyers of a standard that they can rely upon. We are inviting the cooperation of both producers and buyers in working out the problem."

### Reorganization of the Western Classification Committee.

The executive board of the Western Classification Committee at a meeting on December 5, approved the plan for the reorganization of the classification committee and the appointment of a permanent committee of three, to be in continuous session, to hear petitions of shippers or carriers for changes in the Western Classification Committee territory, and make recommendations thereon for adoption in that territory by the western lines.

The board elected H. C. Bush, formerly traffic manager of the Colorado Midland; W. E. Prendergast, general freight agent of the Chicago, Milwaukee & St. Paul, and R. C. Fyfe, present chairman of the Western Classification Committee and a member of the Committee on Uniform Classification, as the permanent committee. Mr. Fyfe will continue as chairman. It will be the work of this committee to receive all applications for changes in classification presented either by the shipping public or the carriers, to make full investigation, and to hold public hearings to which representatives of the Interstate Commerce Commission, state railroad commissioners, and industrial organizations interested will be invited. Also the Interstate Commerce Commission has been invited to have a representative present at the executive sessions of the committee.

This reorganization of the Western Classification Committee is in line with the recommendations of the National Industrial Traffic League and prominent shippers' organizations, and it is understood is looked upon with favor by the western state railroad commissions and shippers as it will greatly facilitate the prompt handling of classification matters and will avoid delays which have occurred in the past when only two classification meetings per year were held by the Western Classification Committee.

The committee of three will, where it is found necessary, or desirable, hold hearings at points throughout the western territory; however, the permanent headquarters and the committee meeting rooms will be located on the eighteenth floor of the Transportation Building, Chicago.

REVENUES AND EXPENSES OF RAILWAYS.

MONTH OF OCTOBER, 1913.

Table with columns: Name of road, Average mileage operated during period, Operating revenues (Freight, Passenger, Total), Maintenance (Way and structures, Equipment, Traffic, Transportation, General), Operating expenses (Outside operations net, Taxes), Net operating revenue (Total, (or deficit)), Operating income (or loss), Increase (or decrease) last year.

REVENUES AND EXPENSES OF RAILWAYS.

MONTH OF OCTOBER, 1913—CONTINUED.

Name of road.	Average mileage operated during period.		Operating revenues		Total, inc. misc. structures, equipment.		Maintenance of way and		Operating expenses		Net operating revenue (or deficit).	Outside operations, net.	Taxes.	Operating income (or loss).	Increase (or decr.) comp. with last year.
	Freight.	Passenger.	Freight.	Passenger.	Freight.	Passenger.	Traffic.	Trans- portation.	General.	Total.					
Pecos & Northern Texas.....	482	192,291	41,630	285,628	24,479	46,592	68,778	68,778	5,423	188,771	22,628	.....	8,826	88,615	-15,972
Peoria & Eastern.....	352	198,290	245,223	31,801	29,087	31,801	121,514	121,514	7,822	194,700	97,441	.....	12,400	86,615	-4,342
Pere Marquette.....	2,325	1,145,470	332,708	2,251,213	379,823	379,823	34,193	34,193	6,835	1,317,462	294,258	5,339	.....	249,705	-159,035
Philadelphia & Reading.....	1,020	3,710,745	614,995	4,537,230	473,213	473,213	52,550	52,550	65,435	2,869,600	1,571,257	6,193	.....	1,571,257	-491,090
Pittsburgh & Lake Erie.....	223	1,544,584	153,092	1,759,121	173,307	173,307	21,005	21,005	28,087	984,181	776,940	660	.....	720,600	-267,552
Pittsburgh, Shawmut & Northern.....	282	198,213	110,468	211,349	51,994	51,994	2,625	2,625	5,423	188,771	22,628	.....	10,000	20,783	-47,747
Port Reading.....	21	112,459	.....	113,468	13,334	13,334	30	30	1,759	48,597	64,871	.....	8,683	64,560	-61,991
Richmond, Fredericksburg & Potomac.....	88	115,853	82,418	230,710	24,082	24,082	2,963	2,963	6,838	156,013	74,697	.....	8,683	65,129	-770
St. Joseph & Grand Island.....	319	91,851	38,444	141,672	31,878	31,878	5,555	5,555	6,426	122,160	19,512	.....	6,244	13,325	-19,499
St. Louis & San Francisco.....	4,742	2,854,704	940,053	4,085,191	567,614	567,614	69,282	69,282	92,038	2,672,710	1,412,481	.....	5,500	1,277,387	-157,771
St. Louis, Brownville & Mexico.....	518	115,762	65,999	197,380	24,112	24,112	4,480	4,480	11,967	186,866	10,514	.....	5,500	5,014	-45,808
St. Louis, Iron Mountain & Southern.....	3,365	2,277,508	526,915	3,010,473	450,973	450,973	49,562	49,562	71,779	1,883,023	1,127,450	.....	9,689	1,028,370	-110,649
St. Louis Merchants' Bridge Terminal.....	903	566,055	124,197	729,784	35,509	35,509	15,870	15,870	1,759	48,597	64,871	.....	3,600	35,482	-26,896
St. Louis Southwestern.....	1,133	589,092	279,008	928,496	103,767	103,767	33,074	33,074	18,726	614,595	315,904	.....	30,232	238,608	-85,309
San Pedro, Los Angeles & Salt Lake.....	3,082	1,610,045	434,167	2,247,453	282,632	282,632	70,800	70,800	66,686	1,486,632	760,850	.....	39,974	271,981	-35,036
Seaboard.....	7,037	4,572,339	1,612,093	6,674,385	753,971	753,971	189,419	189,419	179,447	4,327,350	2,347,035	.....	4,507	2,147,699	-102,596
Southern.....	179	126,009	18,035	149,116	26,688	26,688	48	48	3,912	100,472	48,644	.....	3,020	44,137	-20,919
Southern Kansas.....	163	74,968	23,934	102,889	14,007	14,007	2,197	2,197	28,611	53,399	49,490	.....	3,020	46,470	-7,741
Spokane International.....	556	314,477	137,384	507,301	58,100	58,100	7,571	7,571	13,636	227,735	279,566	.....	53,400	225,398	-9,019
Spokane, Portland & Seattle.....	45	257	273,022	273,022	48,302	48,302	949	949	2,121	176,107	96,915	.....	26,700	72,646	-31,054
Terminal Railroad Ass'n of St. Louis.....	458	221,955	102,355	325,316	44,384	44,384	8,002	8,002	12,968	100,005	42,394	.....	2,948	25,966	-2,325
Texas & New Orleans.....	1,885	1,221,298	425,861	1,857,354	137,140	137,140	38,463	38,463	44,196	1,110,513	747,341	.....	48,000	690,472	-17,445
Texas & Pacific.....	443	453,423	255,736	540,806	85,655	85,655	15,589	15,589	212,924	440,188	100,618	.....	19,117	81,131	-81,852
Toledo & Ohio Central.....	451	361,416	30,160	415,184	47,700	47,700	55,107	55,107	9,530	272,330	142,834	.....	16,600	126,234	-37,129
Toledo, St. Louis & Western.....	463	187,516	48,073	247,158	51,612	51,612	10,370	10,370	13,479	217,521	29,637	.....	6,995	22,642	-93,285
Trinity & Brazos Valley.....	171	98,821	46,412	158,556	26,770	26,770	3,492	3,492	5,340	117,633	40,923	.....	7,800	33,018	-7,255
Vicksburg, Shreveport & Pacific.....	240	156,237	17,106	178,042	21,655	21,655	2,177	2,177	48,800	113,980	64,062	.....	6,181	57,881	-12,726
Virginia & Southwestern.....	503	625,697	33,031	673,526	82,835	82,835	5,925	5,925	9,907	316,348	357,178	.....	22,650	342,195	-144,526
Virginian.....	20	.....	.....	.....	.....	.....	.....	.....	.....	.....	.....	.....	.....	.....	.....
Wabash.....	2,515	1,962,683	668,530	2,867,240	305,141	305,141	96,262	96,262	72,533	2,102,511	764,729	.....	4,832	685,450	-121,674
Washington Southern.....	36	34,833	39,027	102,943	15,177	15,177	1,442	1,442	3,306	78,952	23,991	.....	3,468	20,325	-17,178
Western Pacific.....	937	539,506	133,087	688,402	130,481	130,481	27,449	27,449	24,186	491,282	197,139	.....	31,707	163,792	-66,828
Western Ry. of Alabama.....	133	90,790	49,468	152,637	22,639	22,639	6,636	6,636	6,630	99,157	53,480	.....	4,838	48,411	-2,665

FOUR MONTHS OF FISCAL YEAR, 1914.

Alabama & Vicksburg.....	143	\$400,818	\$176,187	\$89,147	\$128,654	\$15,431	\$216,513	\$22,964	\$472,709	\$150,283	.....	.....	.....	\$29,800	\$118,120	-\$37,454
Arizona & New Mexico.....	109	281,546	37,082	334,079	47,457	47,457	3,003	\$58,038	12,135	\$60,022	174,037	.....	.....	13,600	\$60,457	-\$3,445
Alabama Great Southern.....	309	1,203,535	\$478,748	\$1,288,804	\$222,321	\$222,321	\$53,857	\$58,103	\$8,215	\$1,360,645	\$462,155	.....	.....	\$2,400	\$398,880	-\$66,183
Ann Arbor.....	292	497,468	223,107	721,068	192,280	192,280	19,708	23,547	26,497	494,692	276,346	.....	.....	55,720	220,476	-17,202
Arizona Eastern.....	567	700,630	313,515	900,068	118,637	118,637	8,377	23,474	44,398	557,638	342,474	.....	.....	51,585	290,736	-130,379
Atchison, Topeka & Santa Fe.....	8,357	21,598,445	8,615,866	32,649,588	4,828,119	4,828,119	688,068	8,930,881	730,747	20,984,622	11,664,966	.....	.....	1,516,036	10,148,930	-110,085
Atlanta & West Point.....	93	216,706	171,043	429,236	63,250	63,250	20,304	130,787	19,327	320,592	108,644	.....	.....	25,937	83,715	-10,362
Atlanta, Birmingham & Atlantic.....	645	819,231	244,916	1,156,551	188,397	188,397	56,249	44,664	44,373	927,181	229,370	.....	.....	57,347	172,023	25,200
Atlantic & St. Lawrence.....	167	299,755	143,568	483,572	114,461	114,461	16,380	232,572	15,893	454,585	28,987	.....	.....	40,628	-11,641	27,407
Atlantic City.....	167	280,469	845,049	1,185,080	133,333	133,333	15,907	512,182	7,482	718,549	466,531	.....	.....	36,000	413,870	48,940
Atlantic Coast Line.....	4,619	7,006,187	2,733,739	10,517,149	1,704,381	1,704,381	192,800	393,257	392,865	8,174,531	2,344,618	.....	.....	528,000	1,816,618	-304,221
Baltimore & Ohio Chicago Terminal.....	4,456	6,400,057	3,347	627,770	86,989	86,989	2,803	274,163	20,453	463,793	163,936	.....	.....	64,207	103,494	-5,516
Baltimore & Ohio—System.....	4,77	28,471,415	6,400,057	36,871,768	4,891,573	4,891,573	811,764	13,553,822	765,912	23,926,632	10,891,156	.....	.....	1,061,487	9,541,313	-223,676
Bangor & Aroostook.....	631	823,701	274,327	1,157,723	161,959	161,959	10,192	373,080	43,141	760,645	397,108	.....	.....	39,030	358,048	47,720
Belt Ry. Co. of Chicago.....	21	.....	.....	1,004,169	107,354	107,354	2,174	394,201	24,298	648,228	355,941	.....	.....	38,922	317,019	-83,489
Bessemer & Lake Erie.....	204	3,895,050	186,177	4,131,192	347,871	347,871	46,642	912,020	46,201	2,047,110	2,084,082	.....	.....	132,000	1,932,082	-156,749
Birmingham & Gulf.....	26	566,046	17,606	586,394	31,766	31,766	3,789	91,288	11,117	219,447	166,947	.....	.....	11,416	355,531	148,000
Birmingham Southern.....	43	265,083	4,248	442,233	64,427	64,427	2,035	145,771	16,919	280,180	362,937	.....	.....	7,220	154,833	23,512
Boston & Maine.....	2,252	9,708,765	6,563,596	17,552,473	2,563,686	2,563,686	148,881	7,405,258	405,990	13,155,278	4,397,195	.....	.....	641,483	3,836,543	-825,719
Buffalo & Susquehanna Railroad.....	253	579,817	36,294	631,901	120,962	120,962	7,574	207,998	25,763	454,835	177,066	.....	.....	8,800	168,266	9,379
Buffalo & Susquehanna Ry.....	91	155,264	47,241	214,459	46,634	46,634	6,133	10,082	2,039	20,999	34,180	.....	.....	3,000	31,180	4,778
Buffalo, Rochester & Pittsburgh.....	576	3,122,541	476,934	4,344,474	620,497	620,497	54,878	86,708	12,738	263,073	-48,614	.....	.....	6,400	-55,013	-24,936
Butte, Anaconda & Pacific.....	90	389,438	69,773	456,013	70,347	70,347	2,634	181,866	17,964	2,955,905	1,388,539	.....	.....	9,650	1,316,713	142,527
Canadian Pacific Lines in Maine.....	233	197,807	95,982	329,865	139,751	139,751	25,655	148,524	20,009	413,883	-84,018	.....	.....	44,000	-128,018	74,528
Carolina, Clinchfield & Ohio.....	248	845,720	84,576	950,675	67,520	67,520	27,249	165,604	34,262	402,439	548,236	.....	.....	37,000	511,236	41,508
Carolina, Clinchfield & Ohio Ry. Co. of S. C.....	18	46,308	55,179	2,397	348	348										

## INTERSTATE COMMERCE COMMISSION.

The commission has further suspended until June 11 certain schedules in tariffs of the St. Louis & San Francisco, which proposed to cancel through rates and charges between points on the Kansas City & Memphis and points on, or reached via, the St. Louis & San Francisco.

The commission has concluded to order a reargument of the Tap Line case. It has already perfected an appeal to the Supreme Court from the recent decision of the Commerce Court, and now wishes to determine whether it would be wiser to prosecute the appeal or to modify its own order in the case. The reargument is set for January.

The commission has asked that all applications for extension of time under the terms of the Panama Canal act be filed not later than March 1, 1914. This act prohibits after July 1, 1914, any interest by a railroad or other common carrier, in any common carrier by water, when the former may compete with the latter. The commission has authority to determine questions of fact as to such competition, and it is allowed to extend the time beyond July 1, during which a railroad, or other common carrier, may continue the operation of service by water, if such service is of advantage to the public and if such extension will not reduce or prevent competition on the water route under consideration.

**Classification of Iron and Steel Window Frames and Sash.***Report by Commissioner Clements:*

Protests having been made against certain tariffs which proposed to change the classification to fourth class on glazed or unglazed sash in straight or mixed carloads shipped to Texarkana, Ark., and points in Louisiana, Texas and Mexico, the respondents are now willing to establish fifth-class rates on window frames and glazed or unglazed sash in straight or mixed carloads, minimum weight, 26,000 lbs., with graduated minima as heretofore from official classification territory. (28 I. C. C., 500.)

## STATE COMMISSIONS.

The Louisiana Railroad Commission has ordered the Illinois Central, the Yazoo & Mississippi Valley and the Texas & Pacific to install on their main lines in the state "an approved block system such as will reasonably conserve the safety of life and property," at the rate of at least 20 miles each year, beginning January 1, 1914. The railroads affected opposed the order issued by the commission on the ground of great expense, which they declared to be unjustified and unnecessary. It seems probable that they will take the subject into the courts.

The Louisiana railroad commission has declined to establish uniform class mileage rates for freight on those railroads in Louisiana which use the Western classification. This subject has been pending for the past year. The commission decides that it would be impracticable and unjust to establish the uniform rate. No discretion would be left with the commission to fix rates to conform to particular conditions existing on different roads, and the effect would be to compel some of the smaller roads to carry commodities at a loss, or without profit, in various instances, in order to compete with stronger railroads. The uniform rate proposal was vigorously opposed by the New Orleans Board of Trade and by the railroads, while Shreveport, Alexandria, Ruston, Baton Rouge and other towns strongly advocated it. Another reason for holding that it would be illegal for the commission to fix a uniform mileage rate, was that the state courts had held that all rates should be reasonable.

## COURT NEWS.

The United States circuit court of appeals at Cincinnati has rendered a decision ordering the district court to grant a new trial of the suit against the Chesapeake & Ohio, begun by the heirs of Thomas McKell, who obtained judgment for \$300,000 for breach of contract in failing to provide facilities for hauling coal from McKell's mines in West Virginia.

**Railway Officers.****Executive, Financial and Legal Officers.**

John G. Sutton has been elected vice-president and general manager of the Ocean Shore, with headquarters at San Francisco, Cal., to succeed Alfred Williams, deceased.

James W. Lusk, of St. Paul, Minn., has been appointed a receiver of the St. Louis & San Francisco, succeeding Thomas H. West, resigned. W. C. Nixon and W. B. Biddle, receivers, have resigned as president and vice-president respectively and as directors.

**Operating Officers.**

C. F. Kirchner has been appointed assistant superintendent of the Southeastern division of the St. Louis & San Francisco, with headquarters at Birmingham, Ala.

B. F. Van Vliet, division superintendent of the Chicago, Milwaukee & St. Paul at Marion, Iowa, has been appointed superintendent of the Iowa & Dakota division, at Mason City, Iowa, succeeding W. W. Collins, retired.

E. A. Goeldner has been appointed assistant to the general manager of the Atchison, Topeka & Santa Fe, Western Lines; assistant to the vice-president and general manager of the Southern Kansas Railway Company of Texas and the Pecos & Northern Texas; and assistant to the vice-president of the St. Louis, Rocky Mountain & Pacific, with office at Amarillo, Tex.

J. L. DeForce, superintendent of the Pasco division of the Northern Pacific, has been appointed superintendent of the Idaho division, with headquarters at Spokane, Wash., succeeding A. M. Burt, promoted. T. E. Coyle, assistant superintendent of the Tacoma division, has been appointed superintendent of the Pasco division, with headquarters at Pasco, Wash., succeeding Mr. DeForce. Effective January 1.

E. H. Zeigler, superintendent of terminals of the Cleveland, Cincinnati, Chicago & St. Louis at Cincinnati, has been appointed superintendent of the Peoria & Eastern division at Indianapolis, Ind., succeeding B. C. Byers, transferred. J. A. Morris succeeds Mr. Zeigler and William H. Carter has been appointed trainmaster at Springfield, O., to succeed Mr. Morris. E. M. Kelly, chief despatcher, succeeds Mr. Carter as trainmaster at Bellefontaine, O.

**Traffic Officers.**

J. L. Moore has been appointed general agent, passenger department, of the Northern Pacific at Kansas City, Mo.

J. J. MacEwen has been appointed traveling freight agent of the Western Maryland, with headquarters at Columbus, Ohio.

L. N. Simms has been appointed traveling passenger agent of the Louisville & Nashville, with headquarters at Birmingham, Ala.

E. C. Hoag, division freight agent of the St. Louis & San Francisco at Joplin, Mo., has been appointed supervisor of farm marketing.

William Henderson has been appointed traveling freight agent of the Hawkinsville & Florida Southern, with headquarters at Camilla, Ga.

A. G. Morris has been appointed division freight agent of the Sunset Central lines at Galveston, Tex., succeeding W. R. Smith, resigned.

C. L. Bullard, local freight agent of the Delaware, Lackawanna & Western at Utica, N. Y., has been promoted to commercial agent, with headquarters at Utica.

C. Dallas Douglas, soliciting agent of the Baltimore & Ohio at Columbus, Ohio, has been promoted to traveling freight agent, with headquarters at Columbus, succeeding C. B. Spies, advanced in the service. Harry S. Brown succeeds Mr. Douglas as soliciting agent in Columbus.

U. G. Couffer, chief of tariff bureau of the Pittsburgh, Cincinnati, Chicago & St. Louis, at Pittsburgh, Pa., has been appointed freight claim agent. E. E. Wright, freight claim agent at Pittsburgh, has been appointed assistant freight claim agent, and R. H. Smith has been appointed chief of tariff bureau.

F. C. Baird, general freight agent of the Bessemer & Lake Erie at Pittsburgh, Pa., has been appointed freight traffic manager, with headquarters at Pittsburgh. J. V. Styers, assistant general freight agent at Pittsburgh, succeeds Mr. Baird, and H. L. Baird has been appointed assistant general freight agent, succeeding Mr. Styers.

R. C. Fyfe, who has been appointed chairman of the reorganized Western Classification Committee, with office at Chicago, was born at Kilbourne, Scotland, in 1871. He received a



R. C. Fyfe.

public school education at St. Louis, Mo., and began railway work with the Missouri Pacific as a messenger in October, 1888. He went with the St. Louis Southwestern in August of the following year, and was in the service of that road continuously until January, 1912. He was mailing clerk and in various clerical positions in the general freight office at St. Louis until September, 1898, when he was transferred to Tyler, Tex., as chief rate clerk in the general freight department. On April 1, 1901, he was made chief clerk in the same department, and in December of that year was promoted to assistant general freight agent at Tyler. He retained this position until September 15, 1908, and from September, 1905, was also assistant general passenger agent. He was a member of the Committee on Uniform Classification from September, 1908, until January, 1912, when he was elected chairman of the Western Classification Committee at Chicago, and he has now been made chairman of the reorganized Committee. (See item in Traffic News.)

Harry Charles Bush, formerly traffic manager of the Colorado Midland at Denver, Colo., has been appointed a member of the reorganized Western Classification Committee, with headquarters at Chicago. Mr. Bush was born at Erie, Pa., and received a public school education. In



H. C. Bush.

June, 1871, he began railway work with the Empire Fast Freight Line. From June, 1880, to March, 1885, he was consecutively bill clerk of the Lake Shore & Michigan Southern at Erie; stenographer with the Empire Fast Freight Line at Cleveland, Ohio; agent of the Denver & Rio Grande at Manitou, Colo.; stenographer with the Trans-Continental Association at San Francisco, and stenographer with the Atlantic & Pacific Fast Freight Line. He was contracting freight agent of the Atlantic & Pacific Fast Freight Line from March to September, 1885, and was then agent of the same line until August, 1895, when he was promoted to general freight agent of the Atlantic & Pacific. For two years from 1897 he was assistant general freight and passenger agent for the receiver of the same road, and from the latter year until July 31, 1900, was general agent in the freight department. He was then for three months

general agent of the Colorado Midland at San Francisco, and from November 1, 1900, until May, 1913, he was traffic manager of that road at Denver, Colo. Since the latter date he has been traffic manager of the Idaho & Washington Northern at Spokane, Wash.

James C. Anderson, traffic manager of the New York, Ontario & Western, at New York, having resigned, the duties of traffic manager have been assumed by J. B. Stewart, general freight and passenger agent, at New York. G. L. Robinson, chief clerk in the traffic department, has been appointed assistant general passenger agent, with headquarters at New York.

T. D. Mullaly, freight soliciting agent of the Southern Railway at Tampa, Fla., has been appointed commercial agent, with headquarters at Jacksonville, Fla., succeeding H. K. Lorraine, resigned to engage in other business. J. L. Baker succeeds Mr. Mullaly, and F. E. Harrison, Jr., has been appointed commercial agent, with headquarters at Charleston, S. C., succeeding L. M. Ansley resigned to engage in other business.

W. E. Prendergast, general freight agent of the Chicago, Milwaukee & St. Paul, at Chicago, has been appointed a member of the reorganized Western Classification Committee, with headquarters at Chicago.



W. E. Prendergast.

Mr. Prendergast was born on June 5, 1869, and began railway work in 1884 as office boy to D. T. McCabe, then the general western agent for the Pittsburgh, Cincinnati, Chicago & St. Louis, at Chicago. He then became secretary to Marcus Daley, of the Anaconda Copper Mining Company, at Anaconda, Mont., remaining in that position for two years. He returned to Chicago in 1895, as a clerk to the assistant general freight agent of the Chicago, Milwaukee & St. Paul, and was subsequently chief clerk to the general freight agent. In 1907 he was appointed assistant general freight agent, and on May 1, 1913, was made general freight agent of the same road.

James C. Anderson, traffic manager of the New York, Ontario & Western, at New York, has resigned. President Kerr in announcing this resignation says that: "Mr. Anderson has most ably and faithfully served this company for more than thirty years. He determined some months ago to retire from active business, but at the earnest request of the management deferred his resignation until this time. It is now accepted, upon his insistence, and with great regret." He was born on August 3, 1855, at Newton, N. J., and graduated from Rensselaer Polytechnic Institute at Troy, N. Y., in June, 1876, as a civil engineer. He began railway work the same year as transitman on an engineering corps of the Sussex Railroad, now a part of the Delaware, Lackawanna & Western. From April, 1879, to March, 1881, he was general freight and passenger agent of the Midland of New Jersey, now a part of the New York, Susquehanna & Western. He entered the service of the New York, Ontario & Western in March, 1881, as general freight and passenger agent, and in October, 1904, was promoted to traffic manager. He was also vice-president of the Morris County Railroad, now the Wharton & Northern, from January 1, 1889, to July 1, 1891.

#### Engineering and Rolling Stock Officers.

F. E. Bates, recently assistant engineer of the Chicago, Milwaukee & St. Paul, has been appointed chief draftsman of the bridge department of the Missouri Pacific, at St. Louis, Mo.

J. W. Sasser, master mechanic of the Seaboard Air Line at Jacksonville, Fla., has been appointed superintendent of motive

power of the Norfolk Southern, with headquarters at Norfolk, Va.

A. M. Burt, division superintendent of the Northern Pacific at Spokane, Wash., has been appointed chief engineer maintenance of way, with headquarters at St. Paul, Minn., succeeding W. C. Smith, deceased, effective January 1.

W. G. Coughlin, who has been appointed engineer of maintenance of way of the Pennsylvania Railroad, with headquarters at Philadelphia, Pa., as has been announced in these columns,



W. G. Coughlin.

was born in 1862 at Florence, N. J. He began railway work in 1878 as a rodman on the Madera & Mamore Railway in Brazil, S. A., and returned to the United States the following year. He entered the service of the Pennsylvania Railroad in 1879, in the construction department, and from March, 1883, to May, 1886, was assistant supervisor on the Northern Central, and then to March, 1893, was supervisor of the West Jersey & Seashore, becoming assistant engineer of the Baltimore division of the Northern Central in March, 1893, with headquarters at Baltimore, Md. From July, 1900, to June, 1903, he was principal assistant engineer, and then to April, 1907, was superintendent of the Elmira and Canandaigua division of the same road at Elmira, N. Y. He was appointed superintendent of the Renovo division of the Pennsylvania Railroad in April, 1907, with headquarters at Renovo, Pa., which position he held at the time of his recent appointment as engineer of maintenance of way of the same road, as above noted.

G. Clinton Gardner, Jr., general foreman of motive power on the Manhattan division of the Pennsylvania Railroad at New York, has been appointed assistant engineer of motive power



G. C. Gardner, Jr.

on the Northern division, with headquarters at Buffalo. He began railway work on February 2, 1893, on the Middle division of the Norfolk & Western as inspector at the Roanoke, (Va.) machine shop. In May, 1894, he went to the Philadelphia & Erie division of the Pennsylvania Railroad as an apprentice at the Renovo, (Pa.) machine shop and subsequently was an apprentice at the Altoona shops. After completing his apprenticeship he was made material inspector and later was assigned to special work. On March 25, 1899, he was promoted to motive power inspector at the West Philadelphia shops, and about two years later was transferred to Jersey City, N. J., as motive power inspector in the office of the superintendent of motive power. In December, 1902, he was made assistant road foreman of engines on the New York division, with headquarters at Jersey City, and in April, 1905, was made assistant master mechanic at Trenton, becoming general foreman on the Belvidere division, now a part of the

Trenton division, in December, 1906. In February, 1909, he was made general foreman of motive power on the Hudson division, and three years later became general foreman of motive power on the Manhattan division, in charge of enginemen, firemen, and shops, with headquarters at New York City, which position he held at the time of his recent appointment as assistant engineer of motive power on the Northern division of the same road, as above noted.

J. F. Deimling, engineer of construction of the Michigan Central at Detroit, Mich., has been appointed assistant chief engineer, succeeding A. L. Sarvey, assigned to other duties. C. C. Hill, division engineer, at Niles, Mich., succeeds Mr. Deimling, and F. B. Marble has been appointed division engineer at Niles, succeeding Mr. Hill.

E. M. Keough, roadmaster of the Chicago, Burlington & Quincy, in charge of main line, at Aurora, Ill., has been appointed roadmaster and assistant trainmaster of the Streator branches, with headquarters at Aurora. R. C. Violett, roadmaster of the Savanna lines at Rochelle, Ill., succeeds Mr. Keough; and George Murphy, roadmaster at Burlington, Iowa, succeeds Mr. Violett. H. R. Clark, roadmaster of the Streator branches at Aurora, has been transferred to Burlington, succeeding Mr. Murphy.

C. A. Paquette, assistant chief engineer of the Cleveland, Cincinnati, Chicago & St. Louis and the Peoria & Eastern, has been appointed chief engineer maintenance of way, with headquarters at Cincinnati, O., and the office of assistant chief engineer is abolished. This is in connection with a change from the divisional organization to a departmental organization. Mr. Paquette will have charge of all matters pertaining to maintenance, reporting to the general manager, and engineers maintenance of way will report to him directly on maintenance matters.

#### Purchasing Officers.

W. H. Williams has been appointed storekeeper of the Baltimore & Ohio, with headquarters at Ivorydale, Cincinnati, O., succeeding F. A. Murphy, who becomes traveling storekeeper, with headquarters at Baltimore, Md., and J. R. Orndorff has been appointed assistant storekeeper at the Mount Clare shops, Baltimore.

#### OBITUARY.

Dwight A. Jones, president of the Mississippi River & Bonne Terre, with headquarters at New York, died on December 7 at St. Louis, Mo., at the age of 59.

Henry Martin, vice-president and general manager of the International & Great Northern, with headquarters at Houston, Tex., was drowned at Valley Junction, Tex., on December 5, while directing the road's relief forces in the work of rescuing persons who had been marooned by the floods in the Brazos river. He was attempting to navigate a small boat alone when the craft upset.

NEW RAILROAD OPENING UP GERMAN EAST AFRICA.—An event of great economic importance will be realized early in 1914 by completion of the Central Railway in German East Africa. Construction was begun in 1904 and completed to Tabora, 530 miles from the seaboard terminal, in February, 1912. The railroad when completed will extend 786 miles—from Daressalam, on the Indian ocean, to Kigoma, on Lake Tanganyika. The line divides the German colony into two equal areas, thus making a trunk system from which branches may be built over a great part of the colony. A vast and productive region is thus opened for establishing plantations. It will also become the outlet for the broad hinterland in which lies Lake Tanganyika, with its 400-mile stretch of navigable waters, tributary to which is a rich commercial region in the heart of Africa. Along the extensive shore of this lake products will be gathered and distributed by a fleet of ships co-operating with the railway. German East Africa, with its area of 384,000 square miles and population of 10,000,000, is certain to respond to the economic advantages created by the completion of the Central Railway. Great areas of wild land will be brought into modern cultivation, in which large capital will be invested, new mineral regions and forest areas will be exploited, and public highways will be extended.



## Equipment and Supplies.

### LOCOMOTIVE BUILDING.

THE MISSOURI PACIFIC has ordered 25 mikado locomotives from the Baldwin Locomotive Works.

THE BETHLEHEM CHILE IRON MINES COMPANY, So. Bethlehem, Pa., has ordered two industrial locomotives of the 0-6-0 type from the American Locomotive Company for use in Chile. They will have 19 x 24 in. cylinders, and 46 in. driving wheels; their total weight in working order will be 123,000 lb., and the steam pressure 180 lb.

### CAR BUILDING.

THE GRAND TRUNK is in the market for 500 flat, and 500 stock cars.

THE GRAND TRUNK is also said to be in the market for 110 passenger cars. This item has not been confirmed.

THE NEW JERSEY, INDIANA & ILLINOIS is in the market for 100 freight cars.

THE CAROLINA, CLINCHFIELD & OHIO has ordered 300 stock cars of the Pressed Steel Car Company.

THE LEHIGH VALLEY has ordered 1,000 50-ton steel coal cars from the Standard Steel Car Company.

THE SALT LAKE & UTAH, Salt Lake City, Utah, has ordered 3 motor cars from the Hall Scott Motor Car Company.

THE TOLEDO, ST. LOUIS & WESTERN is negotiating with the Haskell & Barker Car Company for the purchase of 1,000 40-ton box cars.

THE PACIFIC GREAT EASTERN, 404 Welton building, Vancouver, B. C., has ordered 2 motor cars from the Hall Scott Motor Car Company.

THE ALABAMA, TENNESSEE & NORTHERN is said to be in the market for 300 box, 125 gondola and 75 flat cars. This item has not been confirmed.

THE CHESAPEAKE & OHIO reported in the *Railway Age Gazette* of November 21 as being in the market for 2,000 coal cars is now in the market for 1,000 70-ton hopper cars and 1,000 steel underframe box cars.

### IRON AND STEEL.

THE SOUTHERN PACIFIC has ordered 28,000 tons of open-hearth rails from the Tennessee Coal, Iron & Railroad Company.

THE CHICAGO & ILLINOIS WESTERN is in the market for two bridges, a single-span leaf bridge with a 200 ft. span and a through span girder.

### SIGNALING.

The plans of the Lehigh Valley for the year 1914 include the installation of automatic block signals on about 75 miles of line; Van Etten Junction to Geneva Junction, 58 miles, single track, and one mile, double track; Rochester to Honeoye Falls, 17 miles, single track. Power interlocking is to be installed at South Wilkesbarre, with a machine of 68 levers.

The Southern Pacific Company plans to extend automatic block signals on the Pacific system during the coming year about 47 miles; single track, 31 miles, double 16 miles. The plans provide also for electric interlocking machines, General Railway Signal Company's model 2, at Davis, Cal., 80 levers; Palisade, Nev., 36 levers, and Elftman, Cal., 32 levers. Mechanical interlockings are to be put in at Flanigan, Nev., 16 levers, and Eugene, Ore., 12 levers.

## Supply Trade News.

The Detroit Seamless Tubes Company, Detroit, Mich., is now having a new tube rolling mill built under the charge of R. C. Stiefel, of Ellwood City, Pa.

W. J. McKone, for many years traffic manager of the Jacob Dold Packing Company, has been appointed general sales agent of the Metal Car Seal Company, Chicago.

Robert W. Hunt & Co., have begun the publication of a magazine called the *Employees' Bulletin* for members of the organization, made up of material contributed by employees in the form of articles regarding their daily experiences and news items regarding work under construction on which the company's inspectors are engaged.

T. N. Jacob, of East St. Louis, Ill., the chief engineer of the East Side Levee and Sanitary District of that city, from its organization, has resigned to engage in private practice. He may be consulted on levee and drainage projects, railroads, mines and municipal engineering. His office is room 300, Cahokia building, East St. Louis, Ill.

Charles W. Allen, manager of the railway department of the Reading-Bayonne Steel Casting Company, Reading, Pa., has been made vice-president and a director of the Reading



C. W. Allen.

Specialty Company, a company recently organized to sell the cast steel products of the Reading-Bayonne Steel Casting Company. Mr. Allen received his education in the Tamaqua (Pa.) schools and served as a machinist's apprentice in the Tamaqua shops of the Philadelphia & Reading. He later became engine house foreman at Milton, where he remained for six years. In 1904 he was transferred to Reading as master mechanic of the Reading & Harrisburg division. He left this position on January 1, 1907, to become railroad representative of the L. S. Bordo Company, with

which he remained until his appointment as manager of the railway department of the Reading-Bayonne Steel Casting Company. He is the son of G. S. Allen, one of the oldest members of the Master Mechanics' Association, who was formerly a master mechanic of the Philadelphia & Reading, and who served that road for 54 years.

J. W. Hibbard, for many years treasurer of the Grip Nut Company, with office at 500 Fifth avenue, New York, retired from the business of that company on November 1 and is taking advantage of this opportunity to take a much-needed rest and will spend a year or two in travel in an endeavor to improve his health. Mr. Hibbard has a host of friends among railway and supply men.

The list of the various awards made at the International Building Exposition, held at Leipzig, Germany, during the past summer, has been received. Among those who were awarded the gold medal of the exposition and the various silver medals, bronze medals, and diplomas are several American firms, including three engineering organizations and an individual engineer. The Alsace Lorraine prize was awarded to the Board of Water Supply of New York, while Gustav Lindenthal, the American Bridge Company, and the Strauss Bascule Bridge Company of Chicago were awarded the gold medal of the city of Leipzig. Mr. Lindenthal, in connection with the American Bridge Company, exhibited plans of the Hellgate bridge, etc.,

while the Strauss company had a small exhibit of models and photographs of Strauss bascule and lift bridges.

Edgar H. Watlington has accepted the office of eastern sales agent for the Elwell-Parker Electric Company, 50 Church street, New York, with Lucian C. and George W. Brown, who continue as general sales agents of the company. Mr. Watlington was born in Hackensack, N. J., January 18, 1870. He graduated from the high school and was engaged in business for three years before taking up the students' course in 1890 at the Schenectady works of what was then the Edison General Electric Company. On completing this course he took the position of tester in the testing department of the Crocker-Wheeler Electric Company. Remaining with this company six months, he then became superintendent of the Ridgewood Electric Light & Power Company, Ridgewood, N. J. After a service of three years he became a salesman of electrical apparatus with the Sprague Electric Company, New York. Mr. Watlington remained with that company for sixteen years during which time it was absorbed by the General Electric Company. He was active in the development of the electric hoist and was sales manager of that department for ten years. He was then made manager of the newly created freight handling machinery department which had charge of overhead hoisting and conveying machinery and electric freight handling trucks.

Frank A. Purdy, who for seven years has been manager of the Canadian Gold Car Heating & Lighting Company at Montreal, has been transferred to the New York office of the Gold

Car Heating & Lighting Company. He will bear the title of sales manager for the Canadian company and also for the Gold Car Heating & Lighting Company in the United States, with headquarters in New York City. The W. W. Butler Company, Ltd., of Montreal, will act as selling agents for the Canadian Gold Car Heating & Lighting Company. Mr. Purdy was born in the central part of New York State in 1866. His family moved to Iowa in 1868. He began railroad work in 1887 as fireman on the Burlington, Cedar Rapids & Northern, now part of the Rock Island

system, where he remained until 1892, when he went to Chicago to engage in the livestock commission business. In 1905 he joined the staff of the Gold Car Heating & Lighting Company. For about two years he did general field work on the selling force, subsequently being appointed to manage the Canadian company.



F. A. Purdy.

#### TRADE PUBLICATIONS.

**TELEPHONE SELECTORS.**—The General Railway Signal Company, Rochester, N. Y., has issued an attractive booklet illustrating the G. R. S. telephone selector.

**HEAVY PATTERN LATHES.**—Manning, Maxwell & Moore, Inc., New York City, general sales agents for the Putnam Machine Company of Fitchburg, Mass., have issued an attractively illustrated folder describing the heavy pattern, 42-in. coach and truck wheel lathe manufactured by that company.

**STORAGE BATTERY LOCOMOTIVES.**—The General Electric Company, Schenectady, N. Y., has recently issued bulletin A4131, describing its storage battery locomotives and outlining the general conditions under which the use of such locomotives is desirable or advantageous. The bulletin illustrates and describes various designs and sizes which have been built and placed in service.

## Railway Construction.

**CENTRAL NEW ENGLAND.**—An officer writes that second-track work is now under way on 2.3 miles from Highland, N. Y., to Loyd. The O'Brien Construction Company, New York City, has the contract.

**DOMINION ATLANTIC.**—An officer writes that a contract has been given to Kirk & Cooke, North Sidney, N. S., to build from Centreville, N. S., to Weston, 14.79 miles. In addition the company has projected a new line from Sissiboo Falls, N. S., to Weymouth, 8.5 miles.

**GRAND RAPIDS & NORTHWESTERN.**—An officer writes that a contract has been given to the W. S. Syrett Construction Company, Chicago, to build a section of this line between Grand Rapids, Mich., and Ludington, and that all contracts are now let to build the entire line, 98 miles. The company proposes to operate car ferries between Ludington and Manitowoc, Wis., and Milwaukee. There will be one bridge over the Muskegon river. J. N. Tittmore, president, Milwaukee, Wis., and T. R. Philbin, chief engineer, Ludington, Mich. (November 28, p. 1048.)

**KANSAS CITY TERMINAL.**—An officer of this company, which operates a terminal road at Kansas City, Mo., and at Kansas City, Kan., writes that the company is building a double-track extension from Southwest Boulevard to St. Louis avenue, two miles. In addition plans have been made to lay three miles of third and fourth tracks from Prospect avenue to Sheffield, and 0.75 miles of third and fourth tracks from Frisco Crossing to Broadway.

**MONTREAL & LAKE VICTORIA.**—The company is applying to the Canadian parliament for an extension of time to build from Montreal, Que., northerly or northwesterly through Hochelaga, Maisonneuve, Laval, Terrebonne, Two Mountains, Argebeuil, Montcalm, Labelle, Wright or Pontiac counties, Quebec, to a connection with the National Transcontinental near mileage 840 west of Moncton, N. B., and thence to James Bay, near Hannah Bay, Ont. F. L. Wanklyn, Canadian Pacific; Hon. N. Curry, Canadian Car & Foundry Company, and E. Rodier, all of Montreal, are said to be interested.

**NEW YORK, NEW HAVEN & HARTFORD.**—An officer writes that surveys are being made for third and fourth tracks on the following sections: From Woodlawn Junction, N. Y., to South Mt. Vernon, 1.53 miles, and from Atlantic, Mass., to South Braintree, 5.90 miles; between Hebronville, Mass., and Readville Transfer, 23.25 miles of third track and 22.75 miles of fourth track; between Weir Junction, Mass., and Whittenton Junction, 2.10 miles of third track and 2.23 miles of fourth track.

**NEW YORK SUBWAYS.**—The New York Public Service Commission, First district, has awarded contracts for the construction of three sections of the subways as follows: Section No. 1-A of Routes Nos. 19 and 22, the Southern boulevard branch of the Lexington avenue subway, in the borough of the Bronx, from One Hundred and Forty-seventh street under Southern boulevard to Whitlock avenue, to Rodgers & Hagerty, the lowest bidder, for \$2,253,159. This section will be a three-track underground railroad. Section No. 1 of Route No. 16, the Jerome avenue branch of the Lexington avenue subway, from One Hundred and Fifty-seventh street and River avenue through River and Jerome avenues to about One Hundred and Eighty-second street, to the Oscar Daniels Company, the lowest bidder, for \$1,077,978. This section will be a three-track elevated railroad. Section No. 2 of Route No. 18, the White Plains Road extension of the existing subway, from Burke avenue through White Plains road to East Two Hundred and Forty-first street, to Alfred P. Roth, the lowest bidder, for \$958,484. This section will be a three-track elevated railroad. The commission has also opened bids for the construction of Section No. 2 of Routes Nos. 4 and 38, the Seventh avenue extension of the existing subway. This section is to be a four-track underground railroad under Greenwich street, West Broadway and Varick street, between Vesey street and Beach street, including a two-track branch turning from West Broadway into Park Place. Bids for

this section were opened on October 1, but the commission rejected all the bids and readvertised. The Degnon Contracting Company was the lowest bidder on the second letting, at \$3,059,522. The contract for this section will probably be let this week. Plans for Section No. 6 of Routes Nos. 4 and 38, the Seventh avenue subway, were approved and the commission has called for bids, to be opened December 29. This section lies in Seventh avenue between Thirtieth and Forty-third streets, and will include the express stations at Thirty-fourth street (Pennsylvania Terminal) and at Forty-second street (Times Square).

The New York Public Service Commission, First district, has awarded the contract for the construction of Section No. 2 of Route No. 39, the elevated railroad in New Utrecht avenue, in the borough of Brooklyn, to Post & McCord, Incorporated, the lowest bidder, for \$1,672,190. This line will connect with the Fourth avenue subway, and over it Coney Island traffic will reach Manhattan. It is to be operated by the New York Municipal Railway Corporation. Construction work must begin within 60 days after the delivery of the contract, which has not yet been executed.

The commission has required the New York Municipal Railway Corporation to submit to public bidding the contract for the construction of Section No. 2 of the elevated line extension of the Myrtle avenue elevated line to Lutheran Cemetery. This section covers that portion of the Lutheran Cemetery line between Fresh Pond road and Metropolitan avenue. The plans call for a double-track elevated structure about 1,050 ft. long and an approach of about 315 ft., the approach to consist of concrete retaining walls and earth fill.

**OREGON SHORT LINE.**—An officer writes that grading work has been completed on the extension from Donnelly, Idaho, north to Lakeport, 11.72 miles, and second track work is now under way from Dingle, Idaho, to Pescadero, 12.73 miles. In addition the company plans to lay second track from Fossil, Wyo., to Dingle, Idaho, 56.67 miles; also from Pescadero, Idaho, to Lava, 56.70 miles.

All the grading work has been completed on the Salt Lake & Idaho building from Marshfield, Idaho, south to Strevell, 50.08 miles.

**ROME & NORTHERN.**—An officer of this company, which operates a line from Rome, Ga., north to Gore, 18.7 miles, writes that an extension has been projected from Gore, Ga., north to Subigna, eight miles.

**SALT LAKE & IDAHO.**—See Oregon Short Line.

**SAN PEDRO, LOS ANGELES & SALT LAKE.**—This company has location made for a main line between Ontario, Cal., and Otis, but has not yet decided to build such a line. The company now operates over its own tracks from Ontario to Riverside, then over the Southern Pacific from Riverside to Colton, four miles, the Atchison, Topeka & Santa Fe, from Colton to Daggett, 96 miles, and then over its own rails again from Daggett to Otis, four miles.

#### RAILWAY STRUCTURES.

**BALTIMORE, MD.**—The Baltimore & Ohio has completed work on a steel and concrete bridge, 1,530 ft. long, which carries Ostend street over the B. & O. tracks, and turned it over recently to the city authorities with fitting ceremonies. This improvement is part of a program of grade crossing elimination within the city of Baltimore, now being carried out by the railroad company with the co-operation of the city. The plans call for the elevation of five city streets to be carried over the tracks in the Camden terminal. It is expected that the bridge at Hamburg street will be open to the public soon. Under a city ordinance, Ostend, Hamburg, Cross and Lee streets are to be elevated. The agreement calls for the completion of one each year until the work is finished.

**MONROE, LA.**—The Vicksburg, Shreveport & Pacific has started work on additions and improvements to its shops at this point.

**SCRANTON, PA.**—An officer of the Central of New Jersey writes that a brick station is to be built at Scranton, to cost about \$60,000.

## Railway Financial News.

**BENNETTSVILLE & CHERAW.**—This road has been leased to W. R. Bonsal for five years with an option to purchase it. Press reports say that Mr. Bonsal represents Seaboard Air Line interests. The Bennettsville & Cheraw runs from Kollocks, S. C., south to Sellers, about 42 miles.

**BUFFALO & SUSQUEHANNA.**—The Railroad company property was sold under foreclosure on December 5 to Jacob S. Farlee and Lyman Rhodes, representing the holders of the 4 per cent. first refunding bonds, for \$5,000,000.

**CANADIAN PACIFIC.**—The directors have set aside a trust fund from the deferred payments on land sales and securities in which the cash proceeds of land sales are invested, totaling \$55,000,000, and stockholders are offered the privilege of subscribing at 80 to an issue of \$52,000,000 6 per cent. note certificates, due March 2, 1924.

**CHESAPEAKE & OHIO.**—The United States circuit court of appeals has set aside the judgment rendered against the company for \$300,000 for breach of contract and has sent the case back to the district court for retrial, holding that the amount fixed as damages was determined on a speculative basis.

**CHICAGO, ROCK ISLAND & PACIFIC.**—Stockholders are to vote, January 31, on the question of leasing for 999 years the Rock Island, Stuttgart & Southern, which runs from Mesa, Ark., south to Stuttgart, 22 miles.

**DELAWARE, LACKAWANNA & WESTERN.**—This company has called for payment on January 5 the \$6,000,000 balance due on the stock authorized in February, 1913. The first payment of 50 per cent. was made in February.

**LEHIGH VALLEY.**—The report that Drexel & Co., of Philadelphia, have agreed to take \$10,000,000 general consolidated mortgage 4½ per cent. bonds is denied. Vice-President L. D. Smith says:

"Negotiations have not been in progress, much less consummated. The report that the company desires to finance itself before the new public utilities law becomes effective in Pennsylvania, on January 1, is entirely baseless."

"It is very likely that Lehigh Valley will do some financing before the close of the current fiscal year, perhaps in the early spring in order to provide cash for capital improvements. We have bought large amounts of equipment, especially steel passenger cars, and made other expenditures of a capital nature, and as we have not done any financing since 1910, it is not unlikely that we shall enter the money market in the near future. We have not, however, as yet sold any bonds nor are we negotiating for the sale of any."

**ROCK ISLAND, STUTTGART & SOUTHERN.**—See Chicago, Rock Island & Pacific.

**ST. LOUIS & SAN FRANCISCO.**—Thomas H. West has resigned as receiver, and has been succeeded by J. W. Lusk. The other receivers are W. C. Nixon and W. B. Biddle.

W. C. Nixon and W. B. Biddle, receivers, have resigned their positions as president and vice-president respectively, of the company, and retire from the board of directors. On Tuesday of this week Judge Sanborn, of the Federal court, granted the petition of William Niles, of New York, a stockholder, for leave to bring suit against the officers of the road for restitution in the matter of the profits of \$3,975,000 said to have been made by individual officers in the sale of a number of subsidiary lines to the St. Louis & San Francisco.

The receivers have also filed a petition in the courts for permission to begin a suit against former directors and officers for restitution, the application being based on the doings of the syndicate that sold the St. Louis, Brownsville & Mexico to the St. Louis & San Francisco.

**WESTERN RAILWAY OF ALABAMA.**—A semi-annual dividend of 3 per cent. has been declared on the \$3,000,000 stock, payable January 2, thus raising the annual rate from 5 per cent., paid since 1907, to 6 per cent.

# Railway Age Gazette

PUBLISHED EVERY FRIDAY AND DAILY EIGHT TIMES IN JUNE, BY THE  
SIMMONS-BOARDMAN PUBLISHING COMPANY,  
WOOLWORTH BUILDING, NEW YORK.

CHICAGO: Transportation Bldg. CLEVELAND: Citizens' Bldg.  
LONDON: Queen Anne's Chambers, Westminster.

E. A. SIMMONS, *President.*

L. B. SHERMAN, *Vice-President.* HENRY LEE, *Sec'y & Treas.*  
The address of the company is the address of the officers.

### EDITORS.

SAMUEL O. DUNN, *Editor.*

ROY V. WRIGHT, <i>Managing Editor.</i>	H. H. SIMMONS	C. W. FOSS
W. E. HOOPER	H. F. LANE	F. W. KRAEGER
B. B. ADAMS	E. A. AVERILL	A. D. CLOUD
E. T. HOWSON	R. E. THAYER	GEORGE L. FOWLER
	A. C. LOUDON	

Subscriptions, including 52 regular weekly issues and special daily editions published from time to time in New York, or in places other than New York, payable in advance and postage free:

United States and Mexico.....	\$5.00
Canada.....	6.00
Foreign Countries (excepting daily editions).....	8.00
Single Copies.....	15 cents each

Engineering and Maintenance of Way Edition and four Maintenance of Way Convention Daily issues, North America, \$1.00; foreign, \$2.00.

Entered at the Post Office at New York, N. Y., as mail matter of the second class.

WE GUARANTEE, that of this issue 10,300 copies were printed; that of those 10,300 copies, 3,656 were mailed to regular paid subscribers and 350 were provided for counter and news companies' sales; that the total copies printed this year to date were 442,259—an average of 8,672 copies a week.

VOLUME 55. DECEMBER 19, 1913. NUMBER 25.

## CONTENTS

<b>EDITORIAL:</b>	
Editorial Notes .....	1149
The Rate Advance Case.....	1151
The Causes of the New Haven's Troubles.....	1151
New Books .....	1152
<b>LETTERS TO THE EDITOR:</b>	
Comparison of Electric and Hand Trucks in Freight House Service; by R. C. Weller.....	1153
Increase of Efficiency of Freight Equipment; by M. R. Sutherland.....	1153
Can Pullman Employees Co-operate to Improve the Service.....	1154
The Newspapers and the Railways; by Arthur Curran.....	1154
A Yardmaster on Car Efficiency; by H. W. Childers.....	1154
<b>MISCELLANEOUS:</b>	
Points on Running a Locomotive Safely.....	1155
Association of Transportation and Car Accounting Officers.....	1158
The Freight Solicitor's Art; by W. B. Townsend.....	1159
*Railway Buying and General Prosperity; by E. B. Leigh.....	1161
*Canadian Pacific All-Steel Trucks.....	1163
Government Ownership and the Railway Employee; by J. K. Turner.....	1165
*New Devices for the Car Department.....	1167
*Young Locomotive Superheater.....	1169
<b>MAINTENANCE OF WAY SECTION.</b>	
<b>EDITORIAL:</b>	
Editorial Notes .....	1171
<b>MISCELLANEOUS:</b>	
*Schuylkill River Bridge Improvements.....	1173
Responsibility for Minor Derailments; by E. R. Meredith.....	1176
Convention of the Wood Preservers' Association.....	1177
*New Coaling Stations on the Oregon Short Line.....	1178
Bridge Inspection on the B. R. & P.....	1178
Maintenance of Way Master Painters' Association.....	1179
*A Device for Loading Ties.....	1181
New York Public Service Commission Studying Transverse Fissures in Rails.....	1182
*Concrete Tanks on the Baltimore & Ohio.....	1183
Suggestions for Safety in the Maintenance of Way Department; by B. H. Moon.....	1185
*Simple Method of Obtaining Time and Azimuth; by J. A. Macdonald.....	1186
*A Novel and Effective Cattle Guard.....	1186
Making Section Foremen From Clerks; by William S. Wollner.....	1187
*The Branding and Heat Number Stamping of Steel Rails.....	1189
Abstract of Engineering Articles Since November 21, 1913.....	1191
Economy in Cutting Rails; by C. L. Van Auken.....	1191
Annual Track Inspection on the N. Y. C. & H. R.....	1192
*Providing Ordinary Comforts for the Section Foreman; by George S. Crites.....	1192
*Economical Bridge Erection.....	1193
*A Taper Rail.....	1194
*The Fulton Pocket Target.....	1194
*The Absolute Nut Lock.....	1194
GENERAL NEWS SECTION.....	1195

\*Illustrated.

THAT was a very interesting and suggestive paper which E. B. Leigh, president of the Chicago Railway Equipment Co., read at the annual meeting of the Railway Business Association last week. Mr. Leigh's paper, which deals with the relationship between railway purchases and the general business situation, is given elsewhere in this issue of the *Railway Age Gazette*. Of course, while railway purchases are affecting general business, general business also is affecting the amount of railway purchases; but that, as Mr. Leigh points out, the volume of railway purchases produces a marked and great effect on general business conditions, cannot, it would seem, be questioned. If, therefore, owing to artificial causes, rather than normal economic forces, railway purchases are restricted, the inevitable result must be to reduce business activity and the general prosperity. Now, conditions which are chiefly artificial have for some years prevented railway rates from advancing along with the prices of commodities and the wages of labor. During the same period there has been, as Mr. Leigh pointed out, a marked slowing up in railway purchases. This slowing up has characterized not only purchases for current maintenance and operation of existing roads, but also purchases of materials and supplies to be used in new construction. Likewise, there has persisted during this period, with occasional breaks, a serious business depression. There may be differences of opinion as to the exact extent to which the restriction of railway purchases has affected general business; but that it has produced a real and very substantial effect, the statements of fact and reasoning in Mr. Leigh's very interesting paper seem clearly to establish.

IF there still remain a few thoughtful people who cling to the belief that the Interstate Commerce Commission's duties and dignity are judicial as well as administrative, their sense of fitness probably received a rather rude shock when they read Commissioner Prouty's address before the Lotos Club of New York, in which he not only discussed very frankly the merits of a question which is now before the commission to decide on, but, possibly unintentionally, put himself on record as to how that question should be decided. This is all legitimate enough if the commission's duties are viewed as simply administrative and legislative. There is no violation of ethics for a congressman to express his views in the most emphatic manner in regard to pending legislation, and if the commission is nothing more than a branch of Congress, with special administrative duties which give it extraordinary power, it is quite seemly that an individual commissioner express his individual views, although these views may or may not coincide with the final views of the commission as expressed in its formal opinion. As to the emphatic opinion which Commissioner Prouty expressed, that he would not permit an increase in rates unless he were assured in some way that the money so received would be spent for legitimate railroad purposes, Commissioner Prouty follows the trend of the times in believing that men can be legislated into being honest. It would be rather interesting to know whether Commissioner Prouty, if he had been acting as an arbitrator in the trainmen's demands for higher wages, would, after having decided that the cost of living had increased 7 per cent., have withheld this 7 per cent. additional pay from the men unless they could have given him some guarantee that the money so received would not be spent either on unlawful or unethical pleasure. The Hadley Securities Commission recommended that the federal government assume at least sufficient supervision over the issue of new securities by railroad companies to assure full publicity to the purposes for which new securities are issued by railroad companies. But ought this entirely praiseworthy and correct principle to be lugged in and used as a "trade" for an increase in rates?

IT is a curious fact that one thing which has contributed probably more than anything else to the present Boston & Maine situation is that its fixed charges have grown out of all proportion to the margin of safety represented by the investment

of the owners—the stockholders, and that this is the result of the Massachusetts law regulating the issuance of railroad securities. The reason that it was not operative in the case of the New Haven is because the New Haven refused to comply with the Massachusetts law on the ground that it was a Connecticut corporation. The Massachusetts law provides that new stock can be sold to stockholders only at the market value. In other words, if Boston & Maine stock was selling at 140, as it once was, stockholders could not be offered the privilege of subscribing for new stock at 125 or 130, but could buy new stock only at 140. There was, therefore, absolutely no incentive for the owners to raise new capital in this way; in fact it is a very simple proposition that they would be averaging down the value of the stock then held by the issue of additional stock. They, therefore, preferred to get money by borrowing it; namely, to issue bonds which because of the company's then high credit could be sold on very favorable terms. No matter how gilt-edged a stock may be, a stockholder takes the risk, should assume the responsibility and should have the chance of increased profit that belongs to the owner. This fundamental economic fact the Massachusetts law failed to recognize. Shortsighted management may have contributed materially to the present deplorable condition of the Boston & Maine, and real responsibility rests on those who sold Boston & Maine stock to their clients and then failed to do all in their power to live up to the responsibility of protecting their clients' interests; but, on the other hand, the Boston & Maine situation is a rather terrible object lesson of the danger of inexpert regulation of the issuance of securities.

**A**T Shepherd's Bush, on the Central London (underground) Railway, September 30, a signalman caused a rear collision of eastbound passenger trains by a remarkable series of blunders, which Major Pringle, the Board of Trade inspector, describes as "incautious and stupid misuse of electric locking apparatus." This apparatus was Spagnoletti's "lock and block." The collision was not violent, and the story is too long to be repeated here; but the main points may be noted, as an illustration of how it frequently develops that safeguards must themselves be safeguarded. This signalman had been in the service 13 years, and at this post seven months. He had, on the eastbound track, an outer home signal *B* and an inner home signal *C* which, with the starting signal at the station in the rear *A* he had to unlock successively for each train, the locks being first released by the passage of the preceding train over treadles. With these two signals, *B* and *C*, he virtually controlled two blocks, instead of one. His first mistake was to put to the stop position, both *B* and *C*, when the train which he ought to have protected had only passed *B*. Trying to unlock *A* for the next train he discovered his mistake. Then, without learning the position of the first train he hastily concluded that he must clear *C* for it (though its engine had passed *C*) and he went to his emergency release (which he got at by breaking a paper cover); but he went to the wrong one; he released signal *B* instead of *C*. And then, not discovering his mistake, he cleared signal *B*, instead of *C* as he had purposed. The trains had left the preceding station only two or three minutes apart, and the collision soon followed. In a month more the company would have had installed here automatic signals, with track circuits; and so Major Pringle's only comment is that "lock and block working in itself does not afford the security necessary for this kind of traffic." Nor for any kind, he might have said, if emergency releases are to be such an easy resource. Any American signal engineer could have told Mr. Spagnoletti that a time lock should have been used, along with the breakable paper cover. However, as track circuits have been adopted, this question need not be discussed. (Discussion would compel the admission that the perverse human brain will even circumvent time locks.) And, again, some would say that the most significant passage in Major Pringle's report is that which tells us that these emergency releases have

been used at Shepherd's Bush "not infrequently," because the treadles did not perform their function.

**T**HE statement that in one month more track circuits would have been put in use on this part of the Central London puts the Shepherd's Bush collision in the same class with three other recent cases: Melun, on the Paris, Lyons & Mediterranean; College Point, on the Long Island; and North Haven, on the New York, New Haven & Hartford. Each of these roads had begun improvements designed to prevent collisions, but had not finished them. The "P. L. M." had ordered cab signals; the Long Island had ordered the manual block system, to take the place of a mongrel system; and the New Haven road had ordered distant signals where enginemen had been trying to make time without them. Other cases of this kind could be recalled. When a railroad manager decides that a certain investment in safety measures shall be applied at the place where the need is greatest, he exercises a delicate responsibility. If only it had been possible to divine where the next failure in the use or observance of signals would occur, provision could have been made against that failure. The chance of correctly estimating is, however, utterly elusive. Collisions are not only exceedingly rare, when compared with train mileage, but they are very few in proportion to the number of cases of error or neglect which might cause a collision. Good luck seems to save us, very often. The railroad manager, logically, can do nothing but strive for perfect safety at all times and in all places. He must remember the old dictum that "danger lurks in every foot of a railroad." For an expenditure which it is deemed the absolute duty of the company to make, directors will freely and definitely authorize financial provision many months, or years, beforehand. Signaling improvements have not always been thus dealt with because they have not been classed as absolutely necessary. But are they not rapidly coming to be looked upon as belonging to that class? Is it not right that they should be thus treated? How long before some other road will have to answer to the public the same as the P. L. M. now has to answer?

**L**AST week we called attention to the fact that mere words—lectures, personal admonition, circulars or what not—constitute only a part of the means which must be adopted to accomplish a higher degree of safety in doing railroad work. But words have their place, and an important one; and it is instructive to examine the different examples, on different roads, of the way in which the safety-first idea finds expression. The fundamental thought is the same everywhere; but variety does aid in securing intelligent attention. We noticed recently a placard issued by the Grand Trunk, made conspicuous by being printed in three colors. The notices issued by the Northern Pacific, and copied in another column of this paper contain novel features. At the recent New York Central safety-first meeting in New York City Mr. Dow put numerous well known facts in striking phrases. For example: "Let us have inspectors of unsafe practices as well as of [unsafe] cars. . . . *There should be no custom or rule of friendship* to prevent your getting after the habitually careless fellow worker, or to forbid your reporting him where necessary. . . . The officers can give you advice, but they cannot give you your conduct." Mr. Bronson: "Discipline is one of the most unpleasant as well as unpopular duties of an officer. If I owned a railroad and could run it myself I would absolutely abolish suspension. We are trying to get along without it. It is up to you men to make that possible." In another column there is an interesting "safety-first" paragraph addressed to the parents of careless children. In striving for simplicity and directness it is just possible that one may go too far. At the Jersey City meeting, spoken of last week, one speaker illustrated this point by citing a bit of history, to the effect that "safety first" is not wholly a new idea. G. W. Barker, superintendent at Jersey City in the old days of the New Jersey

Railroad & Transportation Company, more than forty years ago, posted all around the yards and shops the notice quoted at the bottom of this paragraph; "and," said the speaker, "that notice stuck in our memories; for it took us some little time to learn what 'paramount' meant!" Who shall say that an unfamiliar word did not, in that case, produce good results? A lawyer, talking to a jury, must simplify to the last degree, because he has but that one chance to present to those men the ideas that he wishes to impress on them. But in addressing men in a campaign—a never-ending campaign—the process of simplification, if carried to extremes, may have a distinctly weakening influence. To introduce words which contain more meaning—and then to do what is necessary to arouse everybody to the duty of getting at that meaning—may be really educational. If a man can be induced simply to read over the synonyms of the word above referred to, the lecturer or instructor who accomplishes that much may fairly assume that he has made a distinct advance in his efforts to impress upon everybody the idea that

"SAFETY IS PARAMOUNT."

### THE RATE ADVANCE CASE.

THE eastern railways deserve to be congratulated on the comprehensive and skilful presentation of their case for advances in freight rates which has been made to the Interstate Commerce Commission. The opening statements made by Daniel Willard and F. A. Delano, the financial and operating statistical data introduced, and, indeed, all the statements and testimony placed before the commission, have been clear and concise, pertinent and persuasive. The evidence seems clearly to have shown that capital expenditures, the return that must be made to capital, and operating expenses, especially the wages of labor, have been increasing so much faster than the earnings of the railways as to make conclusive and imperative the need for increases in rates.

The line of attack which the opponents of advances in rates will adopt is not yet known. Doubtless they will attack the unwise and wasteful financing which has been done by some roads. Doubtless they will try to show that either because of incapacity or dishonesty on the part of their officers some roads have not been as economically operated as they could and should have been. But while they doubtless can show that some individual roads have not been as well handled as they could have been and should have been, it may confidently be said that it can be shown that a very great majority of the roads in eastern territory have been managed honestly, prudently and skilfully. Now, the Interstate Commerce Commission in past decisions has said that in determining rate controversies it will not consider merely the situation of a few roads, but the general situation. If the commission follows that course in this case it is hard to see how it can deny the advance in rates sought or one equivalent to it.

Commissioner Prouty in a recent address has intimated that if the commission should let the roads advance their rates it might demand guarantees that the additional revenues would be honestly and wisely used. As to the propriety of this intimation we have spoken elsewhere. F. A. Delano in an interview in Chicago promptly answered that the roads would gladly give such guarantees. Just what kind of guarantees the commission might demand or the railways give is not entirely clear. It seems quite probable that what Mr. Prouty had in mind was that there should be legislation giving the Interstate Commerce Commission authority to regulate the issuance of railway securities. The results which would be caused by the adoption of legislation giving the commission such power are doubtful. What they would be, would of course, depend very largely on the extent of the power given and the way it was exercised. Unfortunately, while for many years the financing of most of the railways of the United States has been honest and conservative, there have been during this time railway managements that have not done their financing conservatively or, perhaps, even honestly. These exceptions to the general rule give great force in the minds

of the public and the regulating authorities to the argument for some kind of federal regulation of railway stocks and bonds.

It seems highly probable that measures for the regulation of railway securities will be vigorously pushed in Congress this winter, and that some such measure will be passed; and on the whole it seems likely that it will be better for the railways to co-operate with the Interstate Commerce Commission and the proper committees of Congress in framing legislation along this line than for them to oppose it altogether. In other words, if this is the form of guarantee which the commission wants, and to which Commissioner Prouty alluded, probably it will be most expedient for the railways to give it without overmuch murmuring or opposition. The question of railway financing is being connected up in the minds of the public and the regulating authorities with that of rate regulation. It is highly probable that in the long run some form of federal regulation of securities will be adopted. It is also highly probable that postponement of regulation of securities will postpone the adoption of a more reasonable policy of regulation of rates. It would seem, therefore, that on grounds of expediency, the argument for co-operation by the railways in the framing of some kind of legislation regulating the issuance of securities is persuasive.

### THE CAUSES OF THE NEW HAVEN'S TROUBLES.

THE *Chicago Tribune* suggests that "about the worst tack capitalists and directors of capital can take at this time is to attempt to charge up the disaster which has befallen holders of New York, New Haven & Hartford and Boston & Maine railway shares to 'agitation,' to regulation, to 'anti-railroad legislation.' The disaster was the inevitable result of a collision between the inordinate ambition of a group of 'high financiers' and an awakened popular opinion in an uncommonly intelligent region of the world."

This statement is partly correct and partly incorrect. As to the New York, New Haven & Hartford, its troubles are due largely to its management under the Mellen regime. One of the management's mistakes was that it used the money and credit of the road to buy control of numerous properties at prices exceeding what they were, or are yet worth, either independently, or as feeders of the New Haven. The consequence has been that the New Haven has had to pay returns on the securities issued by it to acquire these properties which are larger than the returns, direct and indirect, which it has received from the properties. The effect, of course, has been to reduce the funds available for paying dividends to the stockholders of the New Haven.

Those who made these various deals displayed more ambition, or imagination, or optimism than business sagacity or regard for public opinion. Furthermore, evidence multiplies that the physical development and operation of the property were not carried on as skilfully and economically under Mr. Mellen's administration as they might have been. The stockholders had their responsibility for all this, because the property belonged to them, and it was to their interest and their duty to themselves and the public to use their votes and influence to cause it to be well managed. The directors, likewise, had their responsibility, for they were the men chosen by the stockholders to select the active managers and supervise their work. Finally, Mr. Mellen had his responsibility because he was the man chosen by the directors to be the executive manager of the property. As such he carried out the mandates of the directors either contrary to or in accordance with his own judgment. He says that the former was the case, and seems to think that by so saying he exculpates himself. But it is rather difficult to see how a man occupying an important fiduciary position reduces the blame attaching to unwise or improper conduct of his own by saying that he acted contrary to his own judgment. Men of true self-respect and true loyalty to the interests of those who employ them resign their jobs when attempts are made to compel them to adopt and carry out important policies contrary to their best judgment.

Meanwhile, the stockholders of the New Haven are paying dearly for the past unwise management of their property. Their dividend has been reduced step by step, and at last, at least temporarily, passed altogether.

The present situation of the New Haven is not, however, entirely, or anywhere near entirely, due to the conditions already alluded to. It is suffering from the same conditions from which most of the other railways of the country are suffering. Like them, while the legitimate and necessary investment in its property, and, therefore, the return which it legitimately should pay to capital, have been increasing, its operating expenses also have been increasing so much, owing chiefly to advances in wages, that the net earnings from which to pay return to capital have been declining. Furthermore, largely owing to the same causes, it is suffering from a decline in the net earnings of the companies which it controls. Last week Chairman Elliott gave out a detailed statement regarding the earnings and expenses of the New Haven and its controlled properties, for the first four months of the fiscal year 1912, and the first four months of the fiscal year 1913. The figures relating to the New Haven itself were as follows:

	Four months to October 31.	
	1913.	1912.
Operating revenue, including net results of outside operations .....	\$24,074,710.26	\$25,025,072.38
Operating expenses and taxes.....	17,434,300.99	15,923,557.52
Operating income .....	\$ 6,640,409.27	\$ 9,101,514.86
Other income .....	1,867,432.38	1,732,889.60
Gross income .....	\$ 8,507,841.65	\$10,834,404.46
Deductions—Interest, rentals, etc.....	7,120,962.00	6,295,409.06
Net corporate income.....	\$ 1,386,879.65	\$ 4,538,995.40

It will be seen that of the more than \$3,000,000 loss in net corporate income during these four months almost \$2,500,000 was due to a decline in operating income, and that of the decline in operating income about \$1,000,000 was due to a reduction in operating revenue, while over \$1,500,000 was due to an increase in operating expenses and taxes. On almost all the New England lines, likewise, there were both reductions in operating income and increases of operating expenses and taxes. While the public is visiting its condemnation on the past management of the New Haven it should not overlook these conditions which are affecting that property, as they are also affecting other railways, and for which neither the past nor the present management of the New Haven is responsible. Doubtless it is just that the stockholders of the New Haven and other railways should suffer the results of the un wisdom or incompetency of the directors and officers whom they choose to manage their properties. But because they have been unfortunate or unwise in their choice of directors or officers is no reason why they should be made to suffer not only the effects of their unfortunate or unwise choice, but also the effects of economic developments which the ablest and most conscientious management could not have prevented.

#### NEW BOOKS.

*Master Blacksmiths' Association Proceedings, 1913 Convention.* Bound in cloth. 236 pages. 5½ in. x 8¼ in. Illustrated. Published by the Association, A. L. Woodward, secretary, Lima, Ohio.

A general report of the twenty-first annual convention of the Railroad Master Blacksmiths' Association is given in these proceedings. This includes a complete report on each subject as well as a verbatim account of the discussion in the proceedings. The papers this year were on the following subjects: Flue Welding; Tools and Formers; Electric Welding; Drop Forgings; Piece Work; Case Hardening; Oxy-Acetylene Welding and Cutting; Heat Treatment of Metals; Cast Steel in the Blacksmith Shop, and Efficiency. The same fault exists in this association that is seen in so many of the other mechanical meetings, that an attempt is made to handle far too many subjects for the length of time allowed. The consequence is that nothing is done completely and no important conclusions are reached. In spite of this, however, the work at this convention is interesting and, to a certain degree, valuable.

*Traveling Engineers' Association Proceedings, 1913 Convention.* Bound in flexible leather. 371 pages. 5¼ in. x 8½ in. Illustrated. Published by the Association, W. O. Thompson, secretary, Buffalo, N. Y. Price \$1.50.

The twenty-first annual convention of the Traveling Engineers' Association, held in Chicago, August 12-15, 1913, fully maintained the reputation of previous meetings for the practical and beneficial manner in which the subjects were treated. Reports were made on: Uniform instructions to enginemen on the handling of superheater locomotives; Credit due to the operating department for power utilization and train movement that reduces consumption of fuel; What can be done to eliminate the black smoke evil on locomotives; Advantages obtained with the brick arch in locomotive service, and, Care of locomotive brake equipment on line of road and at terminals. In each case the discussion was thorough and extended. In addition to the reports, a number of prominent railway officials were invited to address the meetings. The speakers included W. L. Park, vice-president of the Illinois Central; W. A. Garrett, vice-president of the Chicago Great Western, and W. J. Tollerton, general mechanical superintendent of the Chicago, Rock Island & Pacific. The proceedings contain the full text of the reports, discussion and addresses and an index of the subjects brought up at each convention since 1893, when the association was organized. The subjects for discussion which will be presented at the next convention and the committees having them in charge are also given.

*Proceedings of the Fifth Annual Convention of the Tool Foremen's Association.* Bound in paper. 6 in. x 9 in. 133 pages. Illustrated. Published by the Association, A. R. Davis, Central of Georgia Ry., Macon, Ga., secretary. Price 50 cents.

These proceedings contain a full report of the recent convention held in Chicago. Many interesting topics were discussed, among which were the reclamation of tool steel, the form of thread and degree of taper for boiler studs and plugs, forging machine dies, thread cutting dies, and superheater tools. This association is made up of expert tool makers, and there is much valuable information contained in its proceedings.

*Railway General Foremen's Association Proceedings, 1913.* Bound in paper. Illustrated. 173 pages. 6 in. x 9 in. Published by the Association, William Hall, secretary, Winona, Minn. Price \$1.

The International Railway General Foremen's Association occupies an important field which is not covered properly by any of the other numerous mechanical associations. That its officers and members fully appreciate their responsibility is well illustrated by the work of the ninth annual convention held at Chicago in July, 1913. The proceedings fully demonstrate their activity and in addition to the verbatim account of the discussions and the full text of the reports, it includes the subjects to be discussed and the chairmen of committees to report at the next convention.

*Air Brake Association.* Proceedings of the twentieth annual convention. Bound in leather. 321 pages. 6 in. x 9 in. Illustrated. Published by the Association, F. M. Nellis, 50 State street, Boston, Mass., secretary. Price \$2.

This association is one of the most logical associations in the railway field. Its meetings are well attended, and the information presented is of great value to the men engaged in the maintenance and operation of air brake equipment. Many of the vagaries of the air brakes are discussed and means found for their elimination. This association perhaps more than any other similar association, calls on the engineering staffs of the manufacturers of air brake equipment and supplies for information that they are able to give concerning special investigations made in their respective lines. This year's proceedings contain papers on Undesired Quick Action; Operation of Long Freight Trains; Operation of the Triple Valve; Air Hose Failures; Location of Steam Heat Traps, and a report of the committee on Recommended Practice.

# Letters to the Editor.

## COMPARISON OF ELECTRIC AND HAND TRUCKS IN FREIGHT HOUSE SERVICE.

CHICAGO, October 22, 1913.

TO THE EDITOR OF THE RAILWAY AGE GAZETTE:

The figures given in an article entitled "Electric Trucks in Freight House Service," which was published in the *Railway Age Gazette* of August 8, purporting to show the saving effected by the use of electric trucks at the Jersey City freight station of the Erie, are somewhat misleading.

In brief, the figures referred to show a cost per ton of 27.4 cents with electric trucks and 38.9 cents with hand trucks. The items shown in the comparison, however, do not include a number of important charges which properly should be made against both systems if a fair comparison is desired. The most important of these items are the cost of the electricians, current, supplies and repairs, depreciation and interest on the original investment. If these be made with corresponding charges against the hand truck system when such charges are incurred, the following comparison will result:

	Electric trucks.	Hand trucks.
Tonnage handled .....	170,170 tons	183,371 tons
(a) Foreman, clerks, coopers, etc....	\$6,425.38	\$6,392.01
(b) Checkers and callers.....	8,715.13	10,830.23
(c) Loaders, stevedores and truckers	31,455.33	54,119.00
(d) Electricians and helpers.....	2,031.69	.....
(e) Electricity .....	962.22	.....
(f) Supplies and repairs.....	617.79	42.00
(g) Renewals .....	1,700.00	63.00
(h) Interest, 5 per cent. on investment .....	1,500.00	105.00
(i) Depreciation, 5 per cent. on investment .....	1,500.00	105.00
Totals .....	\$54,907.54	\$71,656.24
Cost per ton .....	32.27	39.09

The items (a) to (c) inclusive are those quoted in the article as the cost of handling; (d) to (e) are also given and should be included in the comparison. It is to be noted that the cost of electricity was unusually low. At the given daily consumption per truck of 7 k. w. the yearly cost to operate 24 trucks, assuming 300 working days in the year, and a power rate of 4 cents per kilowatt, would be  $24 \times 300 \times 7 \times \$0.04$  or \$2,016, which is more than double the amount given. The items (f) and (g) properly constitute what is usually known as maintenance. As there were 103 hand truckers it is fair to assume that there were 300 hand trucks. At \$7 each their cost would be \$2,100. Items (f) and (g) are computed at 2 per cent. and 3 per cent., respectively, of this amount and the resulting amounts are never exceeded in actual practice. The remaining items (h) and (i) were computed at the rate of interest and depreciation quoted as allowed by the Erie, but it would seem doubtful to anyone familiar with the operation of electric trucks in freight house service whether 5 per cent. is a high enough rate to charge for depreciation. The interest and depreciation of the electric trucks were based on a total cost of \$30,000, assuming the cost per truck to be \$1,250. It will be seen that this comparison reduces the saving from 11.5 cents to 6.82 cents. This amount saved on 170,170 tons handled by the electric trucks makes a total annual saving of \$11,705.59 instead of \$24,745.40.

Furthermore, it is to be noted that the hand trucks moved 183,371 tons of freight as compared with 170,170 tons moved by the electric trucks in the same period. To anyone acquainted with the effects of congestion in a freight house, the fact that about 40 tons per day more were moved by the hand trucks, presumably through the same terminal, will appear to have some influence on the cost.

It is also to be remembered that ultimately the cost per ton should include all overhead charges of the station platforms and other appurtenances that are used in handling freight. For instance, it would be unfair to neglect the interest charge in making a comparison between hand trucking and the telpirage system as the latter requires a much more expensive building. Including all overhead charges, the writer has compiled the following figures from observations of automobile trucks in actual work

at several points. They are not offered in a spirit of controversy but simply for the interest which your readers will undoubtedly have in them.

Tonnage handled per day.	Freight handled by		Possible saving per year.
	Hand trucks.	Electric trucks.	
600 tons	48.6 cents	48.3 cents	\$636.46
700 tons	47.8 cents	47.2 cents	1,190.02
800 tons	47.2 cents	46.8 cents	1,103.11
900 tons	46.8 cents	46.1 cents	1,669.08
1,000 tons	46.4 cents	45.6 cents	2,235.02
1,100 tons	46.1 cents	45.4 cents	2,142.83
1,200 tons	45.7 cents	45.1 cents	2,695.33

The above figures include interest, depreciation, and maintenance on the cost of the buildings and on the equipment necessary for their operation; cost of receiving, trucking and stowing freight; cost of supervision and unproductive labor necessary to operate house; also, where electric trucks are mentioned, the cost of electricity and motormen. All labor was figured on the day wage system.

R. C. WELLER.

## INCREASE OF EFFICIENCY OF FREIGHT EQUIPMENT.

CLEVELAND, Ohio, October 28, 1913.

TO THE EDITOR OF THE RAILWAY AGE GAZETTE:

Increase of efficiency of freight equipment is solved when you have solved your smaller problems. In the first place, the actual handling of the cars is done by a class of men whose main object is the putting in of time and not the achievement of results beneficial to the company. This results in rough handling, causing shop delays, running through switches, causing yard delays, and many similar though apparently small delays, the aggregate of which ties up your cars. Again, take the crews that gather up cars from the industries. Their work is to bring the cars to the outbound classification yard. They will push them in on any track that happens to be empty, right or wrong, and say: "We should worry; let the other fellow dig them out." How is this to be prevented? Increased supervision. If you will spend a night in a large yard and see the number of incorrect moves made because the crews have no one to watch them, you will be convinced that the money thus thrown away will equal the cost of much supervision. I think the railroads are beginning to see the value of increased supervision more and more every day.

Did it ever occur to you how, in our efforts to centralize operations, we make many false moves? Why must every car go to the yard to be classified? In most cases we do not know the destination of a car until it is tucked away in the yard, except, of course, the regular merchandise cars from our freight houses which are classified in most cases on the house tracks. If, however, we were to ascertain from the industries during the day the destination of the cars to be collected from their sidings, much of this classification could be done as the cars are switched out, as a yard clerk could card them before the switcher got there. I believe that an appreciable part of the yard switching could be eliminated in this way.

Another thing; yard discipline is most lax. The men take advantage of the slightest opportunity to "camp." They wait for someone to tell them what move to make next. A crew goes up into a siding for a car. They may be gone twenty minutes or a couple of hours. At any rate, they can tell you what took the time and you have to take their word for it. It is just as criminal for the railroads to allow this condition to exist as it would be for them to leave their cash drawer unlocked. Men are weak and no one has a right to put temptation in their paths. When they see how easy it is to do this sort of thing, it becomes a common practice.

It is true that in many places the railroads lack the facilities to properly handle the amount of business offered them today, but it is not so bad as some would have us think. The weakness lies in the human element. There has been so much talk about this lack of facilities that it has become a Frankenstein and we shrink at the sight of it. The effect is most demoralizing upon the men, who use it as a club whenever brought to account for slow work.



With our system of train despatching we expend every effort to make time upon the road and there our efforts cease. We hold the engineman responsible for maintaining his schedule, and if he makes a practice of falling down, we try the next man out. Why, then, should we not demand better yard performance? This, again, means increased supervision. A yard does not run itself for fifteen minutes except to run away from you. There is no other place wherein a move counts so much for good or bad as in a yard.

It does not take an expert to see what is wrong with a yard, but it does take an expert to successfully run one; and yet we put our yards in the hands of men with a road training and expect them to do it all, for we give them as yard clerks a bunch of young boys in their teens incapable, for the most part, of serious thoughts.

It is the practice at many points, when cars come from another line, to have these cars carded to the agent at the transfer point in question. These cars are lost track of in the yard until billing is received, maybe a day or so later. This causes much delay and expensive rehandling. Cars should be carded to destinations. This calls for a closer co-operation between the railroads.

Another trouble is the conflict between the yard master and the terminal agent as to whose duty it is to do this or that or the other thing. The agent says that the yard clerks come under him, while the yard master thinks they are subject to his orders.

M. R. SUTHERLAND,  
Student in Operating.

#### CAN PULLMAN EMPLOYEES CO-OPERATE TO IMPROVE THE SERVICE?

CHICAGO, November 24, 1913.

TO THE EDITOR OF THE RAILWAY AGE GAZETTE:

On Tuesday night, November 18, I had an experience in Cincinnati, Ohio, which it seems to me is worth calling attention to on account of the frequency with which travelers meet with similar experiences in practically every large terminal in the country. No special criticism is intended on the road mentioned, as the Pullman Company and the station officials appear mainly to blame.

On the night mentioned I reached Cincinnati at 7:40 p. m., and went immediately to the Pennsylvania station to secure a Pullman reservation to Louisville on the Louisville & Nashville train due to leave at 10:30 p. m. I found that all lower berths in the Louisville car had been sold as well as some of the uppers. I reserved and paid for an upper berth. The Louisville & Nashville advertises that Pullman cars operated on trains leaving a terminal after 9 p. m. will be ready for occupancy at that hour. The Pullman agent at Cincinnati advised me that it was usually 9:30 p. m., however, before the Louisville car was ready. On the date mentioned this car was not backed into the station until 9:50, and when the waiting passengers were allowed to board it about 10 o'clock we found that none of the upper berths had been made up. The porter disclaimed all knowledge of the fact that any uppers had been sold and refused to start to make them up until after the train had left, in which he was upheld by the conductor. On account of various delays it was after 11 o'clock before the train left the station, making it nearly 12 o'clock before the last upper berth was made up, and we were allowed to go to bed. The train on which this car is run reaches Louisville at 2:10 a. m., and the car is set out in the station yard. The porter informed us before going to bed that the car had to be vacated at 7 o'clock, and with admirable promptness all the passengers were awakened at 6:30, producing a degree of congestion in the wash room which made it impossible to dress in comfort in time to leave the car at 7 o'clock. It was necessary to leave, however, as the car was pulled out of the yard very shortly after that hour.

After making due allowance for unusual conditions which may have existed on the date mentioned and neglecting entirely to mention the apparent lack of courtesy on the part of the porter and conductor, it is difficult for the passengers who were

denied three hours of sleep to which they were entitled to understand why a little closer co-operation is not possible between the Pullman Company's agents who receive the money and make promises as to the service to be expected and the employees who render those services. It may be impossible for an agent to advise a Pullman conductor that upper berths have been sold more than two hours before the time of departure, so as to allow those berths to be made ready, but if so, most of the traveling public are unable to understand why; and they believe they have an excellent justification for complaint.

FREQUENT TRAVELER.

#### THE NEWSPAPERS AND THE RAILWAYS.

NEW YORK, October 20, 1913.

TO THE EDITOR OF THE RAILWAY AGE GAZETTE:

Your editorial in a recent issue (October 17) on government ownership of railways is excellent as far as it goes, but it does not go far enough. The faults of which you justly complain are not confined to the trashy magazines and yellow newspapers. Some of the eminently respectable dailies disseminate an immense amount of misinformation about railways, and father a great many unsavory schemes. The editors of these newspapers know as much about railroading as a cat knows about calculus, and yet they persist in airing their worthless opinions, and insist upon flouting practical men.

The vicious tendencies of scurrilous publications are well known. It is harder, however, to combat the ignorance and stupidity of that section of the press that is supposedly reliable. Violent and intemperate attacks on the railways do far less harm than the tactics to which I allude.

I could go into this matter further, but do not wish to occupy too much of your space. If, however, you will look into the situation yourself, you will find that what is needed is a campaign to compel newspapers to show at least a decent regard for the truth in dealing with railroad matters.

ARTHUR CURRAN.

#### A YARDMASTER ON CAR EFFICIENCY.

HOUSTON, TEX., December 2, 1913.

Referring to Arthur Hale's letter in a recent issue of the *Railway Age Gazette* about handling freight cars through terminals, it is a big job to keep loads and empties moving in the right direction and requires "eternal vigilance" on the part of all the men concerned. Each department must work in harmony with the other departments to secure success. I find that one of the most essential things is to keep the proper cards on the cars. A car without a proper card or tag is a "dead one," and is bound to be delayed. So is a car with a "hold" tag on it. Other essentials are to get freight lined up properly; be watchful of way bills and keep them with the cars; notify the agent and superintendent of the perishable freight on hand, *and keep it moving*.

A yard master with a poor memory is in a bad fix; he has so many people to satisfy and so many orders on his desk. He cannot carry these orders around with him continually. He must remember them or have responsible engine foremen to execute them. It is most important that there be good, dependable men employed in the yard. Let the men know that you rely on them and have confidence in their ability, especially in the cases of emergency that are forever cropping up in a big yard. Never allow yourself to become excited. Place your industry cars promptly and handle your empties with "promptness and despatch." Keep the "hold" track as clear of cars as possible.

It is a continual dig and a continual fight. Handling a big yard is an exciting game, a big study—and a man's job. "Vigilance" is the watchword in getting cars through a terminal promptly—but nothing counts for much unless you have power to handle your tonnage.

H. W. CHILDEES,

Yard Master, Sunset-Central Lines.

# POINTS ON RUNNING A LOCOMOTIVE SAFELY.\*

Runners' Experiences in New England and Texas; Canada and Mississippi; West Virginia, Saskatchewan and Everywhere.

## ON A CROOKED AND HILLY SINGLE TRACK.

BY CHARLES H. DEFIBAUGH.

Western Division of the Western Maryland.

I give you my personal experience of 23 years of service as a locomotive engineer, a great part of which has been in fast local passenger service, making a run of 114 miles in four hours, 55 minutes; and making 42 stops on each run; over one of the most crooked and hilly single-track railroads in the United States. I have acquired, with a certain degree of success, the habit of keeping a vigilant lookout over every foot of track. I have endeavored to train my mind so that when I step on a locomotive to start on a trip it is free from all thoughts except those relating to the duties to be performed on that trip; and have so trained myself that the manual operation of the locomotive is performed without taking my eye from the track ahead, except for an instant at a time. I have also familiarized myself with the territory over which I run so that the approach to a certain locality brings to me a recollection, a sort of mental picture, of the duties to be performed at that particular locality. I have trained myself so that when anything occurs to temporarily distract attention, to first of all keep in mind the view ahead. When any trivial adjustment is needed, or a defect is to be corrected, not serious enough to require a stop, I call on the fireman to make it, and continue to keep a lookout ahead. I also make it a practice to prompt the fireman to look out constantly when not firing, and this has in many instances been a factor for safety when the view was best from the left side. I have practiced the procedure here outlined so long that all features are now almost involuntary on my part; and I would no more think of running over a piece of track without seeing it than I would attempt to walk on a busy track blindfolded.

I strongly recommend this habit, as I have followed it since a certain day in 1896, when I ran by a train order signal and was suspended for it. After resuming duty again I applied myself especially to making a constant lookout my first and greatest duty; and by so doing I have had but that one suspension in my 23 years of service as an engineer. My experiences have taught me to live up to the rules; to beware of taking chances. "Safety first, speed afterwards." I would summarize the essential things as follows:

The locomotive engineer before beginning a trip should personally examine and know that every part and appliance of the locomotive is in as near a perfect condition as is possible. This will enable him to give his attention more fully to the lookout ahead and the duties of the trip he has started on. When he starts on a trip he should endeavor to free his mind from all thoughts except those pertaining to that trip. He should train himself mentally and manually, so that he can make every manipulation of the locomotive while it is in motion without taking his eyes off the track, except for an instant at a time. He should be so familiar with the territory over which he travels that the approach to a certain locality should bring to him the recollection of a duty to be performed at that particular point. For example, if it be an approach to a station stop, he should have a mental picture (a sort of instinct) in his mind, that he should shut off steam, apply brakes and sound the proper whistle signal; note all visible signal indications, and duly acknowledge the same in strict compliance with the rules. Above all other duties, at all times and places on the trip he should anticipate emergencies and be prepared to meet one without any great degree of surprise.

Occurrences in the cab or about the locomotive in the nature of slight defects requiring correction or adjustment while running should not be allowed to distract the attention of both men

\* These articles, forming a part of the series begun in our issue of November 14, and continued in that of November 28, have been much abridged, the aim of the editor being to give only those narratives of personal experience which supplement, but do not repeat, things told by the writers of the preceding papers.

in the cab from the view of the track and signals. The proper mode of procedure should be for one to correct the defect while the other keeps a good lookout. Should the defect be a serious one a stop should be made for repairs, so that there may be no lapse in the vigilant lookout ahead.

Every engineer should make it a practice to instruct and prompt all firemen to keep a good lookout at all times when not firing or performing their other duties; and should instruct them to perform their duties as much as practicable at times when a lookout is least required from the left side of cab. They should endeavor to impress upon the minds of their firemen that a good lookout ahead is as great and important a duty as their other duties.

If the above described procedure is followed, every engineman can make a good record for safety; a record which will be a great improvement over the present operating conditions of today on many railroads.

## CAUTIONS FOR THE YOUNG FIREMAN.

BY M. J. KRAEMER.

Fresh from the farm, when obedience to parents was the rule, I hired out for a fireman on the Marquette, Houghton & Ontonagon, now the Duluth, South Shore & Atlantic. I was sent to fire engine 27 on a branch line at Republic, Mich. After introducing myself to the engineer, he eyed me sharply and said, "All right, my boy" (I was only 16 years old but I passed myself off as 20), "if you are willing I will make a first-class fireman out of you, which will perhaps assist you to become an engineer of the first class." I started in with a determination to become a first-class fireman; but I will admit that the engineer had a good many laughs on me. But after six months he had no more laughs coming, for I was then as handy with the scoop in cutting a letter "S" distributing coal in firebox as he was. On account of never coming to a shop this engineer had to do his own repairing and, having won his confidence, he asked me to help him do his repairs. The first was putting in engine truck brasses with full explanation of the detail. The next work was lining up cross head gibs and how to find center; the next, reducing rod brasses, shortening and lengthening of main rods, striking point of piston, and lining driving boxes. He also took pains to instruct me in all cases of wrecks, whether on one road or another, with cause, how it happened and how it could have been averted.

When I left this engineer to go on the main line he took pains to tell my new engineer what there was in me, and, behold, I was with another good teacher.

It is not always the fault of the fireman when he ignores the orders of his engineer pertaining to his duties. It is at times the fault of brother firemen, as in my case; sometimes the fault of officers of the company. I myself was informed by two different roundhouse foremen not to pay any attention to the engineer I was with; that he was no good.

The following are things which produce an unsuccessful engineer.

- (1) Indifference while a fireman.
- (2) The virus of hatred planted in the heart of a young fireman against the engineer by officers of the company or by his brother firemen.
- (3) Too fast promotion.
- (4) Indifference of an examiner. Examiners will allow the examined to write questions and answers out of a book, a very good method to make those examined indifferent in their duties.
- (5) Forcing an examination upon a fireman when he himself knows that he is not competent to step on the right side, yet sees that he must do so or lose his turn, and go to the foot of the list. I will admit that we can learn all we need or want to know through books; but books cannot put judgment in your brain; it must come through practice only.

For the last four reasons, officers of the company are to blame.  
*Kamsack, Saskatchewan.*

### KNOW ALL ABOUT YOUR ENGINE, YOUR TRAIN, AND THE ROAD.

BY F. E. PATTON.

There is no doubt that the majority of engineers are well adapted for the service and make good smooth runs without exertion and seldom ever have any trouble to speak of; while others appear to have either missed their calling or have not had the proper training.

In my opinion, the proper habit is partially acquired by observation while firing, and by living strictly up to the rules; and if a man is fortunate enough to fire regularly for a good, cool, level-headed engineer who is in the habit of making smooth runs and is seldom in trouble, he will naturally acquire his habits and do likewise when promoted, provided he has a head of his own.

He must first learn how to locate defects on his engine and have proper repairs made, and if the defects are always found as reported he will never have any trouble getting his work done promptly.

He must next learn how to start a train gently without jerking, and avoid slipping by the use of a little sand before starting. The brakes should be applied a little early in making the first stops after leaving a terminal. He will then know how to brake the remainder of the trip. He should not use steam too soon after a stop or slow down; he must give the brakes time to release and the slack a chance to adjust itself first. Try to improve every trip in starting and stopping, and keep in mind the amount of slack in train, and where it is, at all times. Make a heavy brake pipe reduction on each application before releasing the brake, and there will be less danger of sticking brakes, less damage to draft gear and lading.

Practice fuel economy and good boiler feeding and work in harmony with the fireman. He will have but very little trouble in getting over the road, and by taking advantage of every move to save time, a good average trip can be made without running too fast; and there will be less trouble with hot boxes. An engineer who learns to handle a freight train successfully will have no trouble in handling a passenger train, and he can train himself to do it without hard work or anxiety.

The principal factor in locomotive running is to get right before starting out on a trip; to know when a train is under control; know how fast a train can be run with safety and in what distance the train can be stopped in emergency or in service, allowing a safe margin for the latter, especially in making the first stop on each trip.

Observe all signals, keep a constant lookout ahead for trespassers and animals or other obstructions on the track; be on the alert and ready to respond to any emergency. The engineer should never allow anything to attract his attention away from the right of way. He should teach his fireman to avoid putting in a fire while curving to the left, as it is up to him to watch the track ahead until the end of the curve is reached (especially on fast runs), provided there is no other member of the crew riding on the left side watching the track ahead. They should, however, on leaving a curve and after straight track is sighted and found to be clear, look back at the trucks on train and see if they can detect any defects or hot bearings.

The engineer should never attempt to race with a train on a road running parallel with his road, especially if they have to pass through corporate limits of cities or towns or where their racing would terminate at a railroad crossing; and at a crossing which is clear for him to cross, if there is a train approaching that he has any doubt about he should not start to cross until he is satisfied the other train can stop.

If "white" is used for clear, he should always observe the position of the signal arm at night, as the signal might be set for "stop" and the red lens broken or fallen out.

He should report all tall trees that are on or near the right of way that would fall on the track if blown over.

There are many changeable conditions that make it necessary for the engineer to change his running to suit the conditions. He must think and act quickly. His left ear must be trained to be sensitive to the slightest sounds in the cab, and his right ear as sensitive to sounds outside of the cab; and his mind on every bearing on the engine and train. In fact, the good engineer is an automatic machine and is so accustomed to quick judgment that he does it without exertion. By careful study he learns something along the lines of safety and efficiency each trip, that he never knew before, and the fireman that observes his movements will get the habit, and make good.

When making new time tables I think it a good idea to have four or five of the oldest engineers to advise where the time can be shortened with safety and where more time is needed, as they are familiar with it and can give correct estimates. There are also many suggestions which engineers could make that would improve the service, and they are sometimes timid about calling to the attention of officials; but since the safety first movement has been inaugurated, it comes out without criticism and conditions are improving rapidly.

*Columbus, Miss.*

### FROM A RUNNER TRAINED IN THE NAVY.

BY EDWARD W. WALKER.\*

Never trust the other fellow, or think for a moment that he will be where you think he ought to be, or doing as he should. The only safe course for you, is to assume that he is not, and keep a perfect lookout for him. I think a perfect lookout can be kept without any great strain on the mind, provided the runner is of the proper temperament, and of good health, with an active brain and a retentive memory.

Now, Mr. Engineer, if you are not a perfect lookout, you are an imperfect one. If you are a perfect lookout, these words do not concern you. If you are one of the imperfect ones, brace up, and quickly. Have you a grouch, throw it away. Create a pleasant smile and a cheery manner. Never move your engine without looking in the direction you are going to move, and insist on your fireman doing the same. Then the surprise test will have no terrors. Call all signals to your fireman in a cheery tone of voice. They may be called correctly in a great variety of ways which will prevent monotony. For example: Green eye twice; a pair of greens; two greens we have; yellow eye; cat's eye; red eye, high; red eye, etc. The variations will prevent the force of habit getting the better of you. *Habit may become dangerous.*

Have the fireman run the water; nine times out of ten he would like to do so. You can easily keep one eye on it once in a while. This will give you a better chance to keep your lookout. Live up to every rule as strictly as though your life was forfeit for any infringement. Impress on your mind the fact that yours is the most important position on the train, and that men, women and children place implicit trust in you.

*Wilton, N. H.*

### OLD TIMES AND NEW, IN CANADA.

BY NELSON FULCHER.

The Canadian Pacific Railway was building west from the city of Ottawa in 1882 and was at that time hiring men in considerable numbers. Each new man, as he made his initial run, was picked to pieces and marked down as good or bad as the case might be. One, who may be called Jack, was a good fellow among the boys; and quite well educated. He always made friends. As he was easily led he soon got into reckless company while off duty and never got the proper rest; and as his work was mostly night freight he would consequently fall asleep on the road, with the expected result—a mixup.

\*Mr. Walker runs on the Boston & Maine in New Hampshire. He has been an engineer twenty-one years, six years mostly on night passenger trains. He was formerly and for about 22 years in the merchant marine and the United States Navy.

My turn came for promotion. I had been wiping, and now I was to go firing. I had hoped that I should have better luck and that I should fire for some one else; but no, Jack was to be my first engineer. And from him I got my first lesson, which was caution. I had heard about Jack and had made up my mind to keep my eyes right on him. During my stay with him, there were occasions that I have had to whistle for stations and to shut off steam so as to get the train stopped before we did something wrong; for those were the days in which all brakes were hand brakes. One night, after firing for Jack about one year, it happened that we were on duty at one stretch for close on forty hours, and I was all in. I could not keep up steam to the full pressure. We stalled on a little grade and, the engine stopping, I woke up. I looked over to Jack, who was sound asleep, and I let him sleep until I got her blowing off! Then I shook him and calmly said that if he did not drop her down he would stall. He dropped her down, but by this time she was anchored; so all the blame of backing down and taking another run to get over the grade rested on his shoulders. We both managed to stay awake the rest of that trip, as we then were near the terminal.

Shortly after this incident I was promoted, and was sent on the next division to handle a freight run, while Jack was on the home division running a night passenger. But one cold morning we heard of a terrible wreck where four had been killed and seven badly hurt. The coroner's inquest enlightened us to the fact that Jack had run two miles past his regular time card meeting point and was asleep when he hit No. 2. Needless to say he lost his job. No engineer can do his duty if he does not take his proper rest.

Within the last few years here in Canada there has been passed a "Lord's Day Act," and it is one of the best. Since the passing of this act it is noticeable that there is a decrease in the number of trains run on Sunday, such as way freights, work trains and excursion trains; and as a consequence the employees are at home or at church. This tends to elevate the standing of the engineer himself as a citizen. It places him on a par with other men. Instead of being liable to a call at any time on Sunday he is now a man who can look forward to Sunday as a day of rest. That, to my mind, is a country-wide recognition of the fact that an engineer needs proper rest.

Within the last few years the entire responsibility for the speed and handling of every train has changed from the train crew to the locomotive engineer. His responsibility is increasing each year. Each year the public demands better service, each time examination becomes more strict and discipline more rigid. There never was a time when as much was required of the engineer as now.

*Sault Ste. Marie, Canada.*

#### ENGINEER MUST BE CONTENTED.

By E. C. LAUCK.

The only way you can acquire this faculty of knowing everything pertaining to your duties is to be contented. Contentment in any life, if there can be such, would mean the height of success. It is said that no man was ever fully contented, but the higher the degree of contentment attained, the higher his success.

The following narratives present actual experiences, and I confess they have taught me a lesson. I have tried to profit by my experience and have, to a certain extent, succeeded. Not one penny has it been necessary for a railroad to spend on my account since I learned my lesson.

Some years ago I was working on a certain railway in Canada as an engineer. I was assigned to a work-train working about eighteen miles from the away-from-home terminal. Saturday nights we tied up at the away-from-home terminal, which allowed us to have the necessary repairs done on the engine, but gave us a poor chance of getting home to stay over Sunday. The only chance we had of getting home was to dead-head on a passenger train which came along about eight o'clock in the evening. If we missed

this train we had nothing to do but sit and look at the mountain scenery until time to go to work Monday morning. This particular Saturday we were late in getting through work and of course it put us on short time running the eighteen miles which lay between us and the passenger train. After we had got our orders and were ready to start, the time had narrowed down to a minimum, and in order to get in on time the iron horse had to be given a little extra steam to urge her along. You have often heard, no doubt, that two trains could never pass on the same track. I was thoroughly convinced of this after that night. About ten miles from where we had started we struck an open switch and headed in on another train on the siding, that was preparing to pull out on the main track. This happened inside of yard limits and anyone familiar with train rules knows that I should have been running under control. The impact of the two trains was terrific. It has always been a mystery to me how anyone escaped being killed or at least maimed for life. I suppose Providence was with us and it was not ordained for anyone to suffer. I laid the cause of this wreck to the want of contentment. Some may say it was caused by not attending to business. I agree with them, but if I had been contented I should not have been in such a hurry to get to the terminal and in all probability I should have gone through those yard limits under control, as the rules required; and I could have stopped. My mind would have been on my business and I could have seen the open switch. My eyes were riveted on the track, but I was blind to the open switch.

To illustrate again: Some three years after the wreck just mentioned I was running an engine on a trunk line in the southwestern part of the United States. Going out on the road one night not feeling any too good, for the want of sleep, I experienced a lesson which made a deep impression upon my mind. The last ten miles of the run was up grade. After getting the train stretched out on the hill we were making not over eight or ten miles an hour. My duties then were reduced to a minimum and my mind commenced to wander, chiefly thinking of that cozy bed awaiting me upon my arrival. A feeling of envy sprang up in my heart for those who perform their duties in the day time and can sleep at night. That frame of mind overtook me and I was soon in slumberland. I slept on. I awoke in a dazed condition, startled out of my wits, and, lo, what did I see? The beams of the headlight fell upon a string of cars. Naturally, I reached for the brake valve, throwing it in the emergency position, but no sooner had I done so than I saw my mistake and I threw it around in full release position. Anyone acquainted with the air brake knows the result. To size the whole thing up, I had gone to sleep and on entering the terminal the reverberation of the sound caused by the movement of our train between strings of cars on either side awoke me with a start. The track was slightly curved and of course the headlight showed directly upon a string of cars and I took these cars to be another train; but in reality they were only storage cars in the yard. The consequence was three draw bars were pulled out and the ends of two cars loaded with perishable fruit. "What caused the wreck?" "Non-attention to duty caused by a discontented habit of mind."

I could relate many similar cases, but it would not be fair for me to tell of another man's faults. When you get contentment for the individual on a locomotive you have solved the problem of how to avoid 99 per cent. of the wrecks which enginemen are to blame for.

*Denison, Texas.*

#### THE CHANCE TAKER.

By "OBSERVER."

Speaking generally of the difference in engineers, while they are all trying to handle the business promptly, there is a class that are unfortunate in a way, while yet they get the best protection that the train despatcher can afford because

they are "chance takers" and will do any kind of a stunt to run around some other man, regardless of conditions, in order to keep on the good side of the despatchers.

There are others whose intentions are good and they try to do everything exactly right, yet their style doesn't always suit certain despatchers. If they fail to make a close run the despatcher will give them bad handling afterward. There is only one cure for this, and that is for the road foreman to ride with him, by request of the trainmaster, to ascertain the trouble. He finds that he is all right. Then, of course, the road foreman will ask him about some poor trips he had made recently and when advised of the insulting telegrams he had received and the deal the despatchers gave him on certain trips, he will tell him to go ahead and keep doing the right thing; things will clean up and the runner will turn out to be one of the best men.

The despatcher can fix the train sheet up in fine shape for the chance taker, and the superintendent thinks he is a "wonder" until he gets him on the carpet.

He often gets to his engine late and asks the fireman to oil around for him, while he changes his clothes, and after the air test he is ready to leave, not knowing whether the sand pipes are open or whether they will hit the rail or not; however, he is a "hot shot."

He fails to stop for a block that is set at "stop" because he found this block out of order on a previous trip.

There are some men that are a little weak, who apparently have been promoted too soon on account of a rush of business. Others will never make runners as long as they live, and their firemen will no doubt acquire some of their habits also. There should be some method adopted to determine the fireman's knowledge and ability at certain periods, and if he is found to be bright but firing for the wrong man, have him changed and watch the results. If a man is found to be lacking in ability, have him advised that his services are unsatisfactory, unless, of course, he can be set right in some way. This can be largely overcome by close observation.

The first trip I fired on a passenger run was for a man who did not care if I put in a fire on a curve to the left, which I did thoughtlessly on account of being used to doing it on freight, having the head brakeman on the seat looking ahead. After I had discovered my mistake I started to apologize to the engineer for my ignorance and the first word I spoke, he closed the throttle and applied the brake in emergency (while running about fifty miles an hour on straight track) and asked me what I had said. I then saw my finish, and his also, if I remained on the run with him, but I managed to make a change without losing his friendship.

While firing a yard engine one day I noticed a covered wagon trying to cross ahead of us while we were shoving four or five cars about six miles an hour. I signaled the engineer to stop and he quickly applied the brake. We did not strike the wagon, but the jerk threw the conductor from the top of a box car to the ground, striking his head on the rail, fracturing his skull. This taught me to ask the fireman if all was clear before shoving over crossings.

Another dangerous practice is the brakeman going in between on the engineer's side to couple hose and crawling through to the other side to give the fireman the signal to move, while the engineer is waiting for him to come out on his side before he will move. This causes delays because the engineer should not move until he was positive the signal was given by the same man that had gone between the cars.

I have made several mistakes in failing to compare time. I was running on a time order with my watch stopped, and as I appeared to have plenty of time was not crowding the engine, and I noticed the conductor coming over the train in a hurry. I looked at my watch and found that I had the same time that I had when I started; then "business picked up." Another time my watch lost ten minutes on the trip and I had not noticed it because I had not compared time.

The watch was running and I had great confidence in it.

## ASSOCIATION OF TRANSPORTATION AND CAR ACCOUNTING OFFICERS.

The winter meeting of the Association of Transportation and Car Accounting Officers was held at the Hotel Galvez, Galveston, Tex., December 9 and 10, with 126 members in attendance, and President F. Price in the chair.

The report of the executive committee shows a membership operating 260,334 miles, and having in service 2,631,966 cars. J. M. O'Day (chairman), T. S. Bell and J. W. Nowers have been appointed a committee on conference to consider subjects jointly with a similar committee of the American Railway Association and the Master Car Builders' Association.

The association did not approve the recommendation of the Committee on Car Service that per diem rule 8 be modified to provide that when a car is detained awaiting receipt of repair material which must be obtained from owner, per diem should cease from the date the necessary material is ordered from the owner until the date on which it is shipped, and that repair material exceeding 125 lbs. in weight be shipped by express. In this connection the association recommended to the American Railway Association that rule 8 be abolished.

The form for use by shippers in ordering empty cars for loading, and the form of station record for use by agents in recording orders for cars, presented by the committee, were adopted for submission to the American Railway Association. The association concurred in the recommendation of the committee that it is undesirable to make any change at present in Car Service Rules 1 to 4, which prescribe the method of returning cars to owners.

The committee on continuous home route cards recommended a form of universal home route card, to be provided by the car owner and to accompany each car delivered off its rails. The card is to remain with the car during its entire absence from the home road, to indicate the proper route of the car when empty, but to be so utilized as not to interfere with the application by the possessor road of the spirit of car service rules 1 to 4. It also recommended that the universal home route card be handled in the same manner that card waybills are handled today, believing that the attaching of the card to the car would be undesirable. In the opinion of the committee the adoption of the proposed method would contribute to a more prompt handling of cars and would eliminate a large proportion of setbacks and delays. Under the use of the proposed card, it will be unnecessary to hold cars awaiting home route information, and agents will at all times have at hand information to enable them to load or route cars by routes that will secure their return to the owner with a minimum haul. The full information provided will eliminate the difficulty that frequently arises where a car is doubled back on any given route. The committee feels that one of the greatest benefits to be derived from the use of the proposed card is the elimination of cross hauls of empty cars, as well as the elimination of long hauls over circuitous routes of cars en route home, where substitute short routes could be provided by careful observation of the data accompanying the car.

The proposed card was adopted by the association with minor changes, for submission to the American Railway Association. The association also recommended to the American Railway Association the amendment of car service rule 5 to provide that each car delivered in interchange shall be accompanied by the owner's universal home route card.

The list of accepted assignments of reporting marks for private cars, presented by the committee on office methods and accounting, was adopted for submission to the American Railway Association. The report of the committee indicated that approximately 300 owners of private cars have accepted assignments of reporting marks.

In this connection, the committee also presented a list of assignments of reporting marks to cars of railroad ownership

which has been prepared with a view to preventing duplicate reporting marks. The list embraces an assignment of marks for every standard gage railroad in the United States, Mexico and Canada, and, in due time, it is contemplated that all cars will be stencilled with the assigned reporting marks. The marks are limited to three letters, except in certain instances where "&" is used to enable car owners to use reporting marks which correspond to the corporate initials of owner. The committee requested that the list submitted be adopted in principle only, and that authority be continued with it to modify any assignment on request of car owner where it is possible to do so without duplication of reporting marks. The association instructed the committee to submit each set of assigned reporting marks to each railroad, with an appropriate communication, in order to afford opportunity for car owner to definitely accept it.

In connection with the subject of per diem in the case of cars placed on industry tracks which are accessible to two or more railroads not protected by an interchange report, and which cars are taken off of those tracks by a road other than the one placing them, the association adopted the following rules for submission to the American Railway Association:

1. Empty cars diverted to or confiscated by another road, either loaded or empty, should be reported as interchanged as of the date and time originally placed by the delivering line.
2. Loaded cars after being unloaded, diverted to or confiscated by another road, either loaded or empty, should be reported as interchanged as of the date and time released from inbound load.
3. Loaded cars reconsigned with the original load should be reported as interchanged as of the date and time reconsigning orders are delivered to the receiving line.

The association concurred in the opinion of the committee that it is undesirable to recommend a modification of rule 1, code of per diem rules. The association adopted the recommendation of the committee, for submission to the American Railway Association, that two weights of paper be used for the interchange report form No. B-1, as follows: First: That the main report, which is filed intact, be printed on a good quality of bond paper of the basis of 14 lbs. to the ream of 500 sheets of the size 17 x 28 in. Second: that the sheets which are to be cut up be printed on a good quality of bond paper of the basis of 24 lbs. to the ream of 500 sheets of the size 17 x 28 in.

The committee reported adversely on the suggestion to publish the names of roads that are delinquent in the matter of forwarding junction cards daily, and was sustained by the association. It is recommended by the association that cases of delinquency in this respect be brought to the attention of the chairman of the committee on relations between railroads of the American Railway Association. The committee on office methods was also requested to consider the subject of missing junction reports.

The committee reported that, at the request of the American Railway Association, consideration had been given to the question of devising and recommending a uniform and efficient method of sealing cars and maintaining a seal record. The association requested that the tentative draft of rules, submitted by the committee, be mailed by the secretary to each member of the association for consideration and recommendation as to changes; and also adopted a resolution requesting the cooperation of the Freight Claim Association in the preparation of a final code of rules to govern the use and recording of car seals. The association adopted the recommendation of the committee that each carrier insert in its registration the name of the officer to whom orders for repair material should be forwarded, and that the publishers of the *Official Railway Equipment Register* be requested to insert this information.

Investigation of the committee on conducting freight transportation develops the fact that comparatively few box cars are marked on the interior with a grain line, and that where the grain line has been applied there is no uniform practice with reference to including or excluding the usual 10 per cent. above marked capacity of cars. The association recommended to the

American Railway Association that action be taken through the proper channel to secure the application of grain line marks on the interior of all cars suitable for grain loading, and that such line be located so as to include 10 per cent. above the stencilled carrying capacity of the car. The association also recommended to the American Railway Association that suitable cards be attached by the car inspector, agent or yardmaster, both inside and outside of each car, immediately a leaky condition of roof or sheathing is discovered.

The committee on joint interchange and inspection bureaus reported the establishment of a joint bureau at Shreveport, La. The committee is informed that the roads entering Dallas have determined to extend, for experimental purposes, their present car inspection bureau to include the preparation of the interchange reports. The Des Moines bureau reports that since its inception not a single complaint has been received with regard to the interchange record at that point.

Reports of progress were received from the committees on handling railroad business mail and conducting passenger transportation.

D. C. Cheney, fuel inspector of the Chicago, Milwaukee & St. Paul, presented an article on equated train tonnage, illustrated by the forms in use on the Milwaukee.

It was decided to hold the next meeting of the association at Savannah, Ga., June 23 and 24, 1914.

## THE FREIGHT SOLICITOR'S ART.

By W. B. TOWNSEND,

General Agent of the Missouri Pacific-Western Pacific System, Oakland, Cal.

I have just finished reading a news item wherein it is stated that an ex-freight solicitor has been appointed to a \$50,000 position on one of the largest railroad systems in the country, a man who ten years ago, was soliciting freight at San Francisco. It was soon my pleasant experience to note how well this official stood in a community which he had left some ten years previous, as evidenced by expression of opinion when he returned to San Francisco connected with a new road. Soliciting freight under him and making frequent visits on business houses I was surprised at the number of merchants who wished to be remembered to our new official, and who went out of their way to give him their freight, and even to induce their friends also to swing their business his way. Here was a man with a personality that could not be forgotten in years. Such a man is sure to be valuable to any railroad, whether in an official or a minor position. A man who can secure and control freight for his system is a big factor. For the time being the railroad does not count.

I have also had occasion to see the result of the work of another official who had previously solicited freight on the coast and now visits it once a year. Although this man represented a small road with a short haul, and has not lived here for ten years, he made such a good impression and was so conscientious in his work while here, that his old friends still say, "I want to put Harry in on this car, if I can help him." So many of them said this that he has now been appointed to a position of great responsibility where his personality will count in a larger field.

The ideal freight solicitor is a man between the ages of twenty and forty years, athletic and of good appearance. He should come to the office in the morning shaved and with a clean collar, and should be anxious to get out on the street and amongst his friends. A man that hangs around the office and talks baseball or prize-fights, and is afraid to get out in the rain, will never be anything better than a solicitor; he is lucky to hold on to that. Above all things, a man should be proud of his business and take a pride in his road. The solicitor has something for sale, namely, transportation, and the transportation business is an honorable calling. A good solicitor should be industrious. He

should be a good mixer and be able to talk to the officers of a church and secure a routing order covering a church organ, and then go from there and secure an order for a car of beer or whiskey from the leading saloonman. He should maintain a proper dignity in one case as in the other. In this connection it is in order to observe that the day of taking the shipper or consignee up to the bar and getting him full in order to secure his business is past, way past. The freight solicitor who insists on these tactics to secure his freight only makes himself a nuisance and gradually loses his friends. The big man in any business has no time or inclination for anything of this kind.

The traffic manager of any large shipping concern, after getting acquainted with a solicitor takes an interest in him; and a nice luncheon will generally help matters. Most men are fond of cigars, and a freight solicitor should be well supplied with them; but I have seen many cases where a cigar given in the wrong way hurt more than it helped. Do not give a man a cigar until you are through asking for his business. To give him a cigar and then ask him what he has for you looks too much like a bribe. Another thing: a freight solicitor should never smoke while making his visits. This gives offense in many instances and by many he is thought fresh or rude.

Be courteous and carry out all your promises. If you promise a consignee that you will look up certain rates for him, give him this information at the earliest possible date, and if he is promised a map, a calendar or a picture, see that he gets it as soon as possible; otherwise he will lose confidence in you and in what you say. Keep the merchants posted as to any changes in the tariff. Treat your friends right and they will treat you right.

It is never necessary to stand for insults or abuse from a merchant. Today one of the most successful traffic men on the coast told me a story that is worth repeating:

Calling on a hard customer who had never given him any freight he was ignored; the manager started up the stairs to the second story. He was followed by the solicitor. Upon seeing him there he started for the third story, and was again followed by the freight man, and likewise up to the fourth story of his building. This was the last story, and he could go no farther. On being cornered he turned to the solicitor and said, "Well, what do you want?" The freight man answered, "I only want to be treated courteously and receive an answer to my question." The manager said, "Why don't you talk to our traffic manager?" He then took the agent to the basement and said to his subordinate, "I want you to treat this gentleman right when you ship our freight. He is a friend of mine; from now on see that he gets his share of our freight." Here was an instance of following a case through, and it eventually happened that this road received a big share of this shipper's business. The freight solicitor who got this business is now vice-president of a big system.

Another case where a solicitor made a ten strike was as follows:

There was a merchant in San Francisco who took pleasure in insulting all freight men that visited him, regardless of how polite they were, or what road they represented. One morning a new freight solicitor, who was just out from the East and trying to get acquainted in his new field, visited him. Upon handing out his card he was surprised to see the old curmudgeon tear it up and throw it into the waste-paper basket; and the door was opened for him. He left, but returned in a few minutes and the same thing was repeated. After waiting outside for ten or fifteen minutes this freight solicitor returned with a smile on his face, and removing his hat handed the merchant his card for the third time, looked him in the eye and said, "You read that card and then put it in your pocket or desk, or I will make you eat it. I am going to teach you a lesson in manners this morning." A look of surprise came over the merchant's face. He saw that his bluff had been called

and he immediately assumed a different attitude; and ever since then he has put himself out to be friendly with and favor this man who had shown him his error.

Never tell a lie or shade your stories. I have seen railways lose all of a man's business on account of their solicitors giving him the wrong delivery date or passing record on their cars. Be a good winner and also a good loser. Only now and then can you expect to get all of a man's business. Seventy-five per cent. of the merchants like to divide their business and you can only increase your proportion of their business by showing them good service, good time and satisfactory passing records; prompt switching of cars to their spurs at destination and fair and prompt settlement of their claims. When you show them that you are watching their interests they will show you that they are with you also.

A good freight solicitor is a good judge of character or human nature and studies all his customers. What will appeal to one man will offend another. An experience which I had in my early days of freight solicitation will bear this out. I went to work as contracting freight agent for a fat, good-natured man whom everyone liked. I had previously been traveling passenger agent and did not know a reefer from a box car. After I had received a city map and had got somewhat acquainted with my territory, my new boss told me he would show me how to get freight and how to get acquainted. I made up my mind to watch very closely and to try to be a successful solicitor. The first man we visited was a commission merchant, who shipped from four to six cars of beer a month from the east to California. The first thing my new boss did was to dig the commission man in the ribs and swear at him, finally finishing up by saying: "Dan, you old stiff, I want a couple of cars of beer from you this morning, just to show this kid how to get freight." He got them; but not everyone could get away with that kind of stuff. I had to work out my own salvation in regard to approaching a man and getting away after the interview.

After securing an order covering a movement of freight by your lines, it is a good thing not to hang around too long. I have known of cases where a man spoiled his business by trying to tell two or three long funny stories after he had been successful in getting the freight. This practice very seldom makes a hit and had better be dispensed with.

Be loyal to your road and its officers and carry out its policies. If they do not coincide with your ideas, follow instructions, or quit and go with some other road. Do not knock or criticize. Praise your road, even though it be a streak of rust running from no where and ending in the bushes.

A good solicitor is always trying to discover new leads. He is on the lookout for some man who controls freight but whom the other lines are not in touch with. Many a man that makes his office in his home, or boarding house, or under his hat, controls routing on big freight. A natural freight solicitor will uncover many a good customer. More credit should be given to a solicitor of this kind than one who only follows a beaten path. A man that works for his company as though it were his own business will succeed. I remember a case of a traveling freight agent who worked hard all day in a hot Texas town without securing any business at all. He was so disappointed he could hardly eat his dinner. But he was up early the next morning and at it again; and before noon had secured some big business. Today that man is general eastern freight agent of one of our largest systems, and a successful man in his line.

Summing up the most important qualifications for a successful freight solicitor, I would say smile, tell the truth, cut out the drinks, be neat in your appearance, keep moving and don't be afraid of working hard; and some day you will find your superiors have come to the conclusion that you are too good a man for a small field, and have added to your title.

# RAILWAY BUYING AND GENERAL PROSPERITY.\*

Do the Purchases of the Roads Initiate General Business Activity, and Are They Necessary to Sustain It?

By E. B. LEIGH,

President, Chicago Railway Equipment Co.

What is the matter with general business? What can be done to restore activity? There are conclusive grounds for believing that the largest single factor in the present interruption and rapidly approaching business depression was and is the enforced and continued curtailment of railway purchases. No factor which could now be introduced into the situation would do more to stimulate general business out of its present and impending condition than a vigorous resumption of railway expenditures. This conclusion, while applying to the state of affairs at this moment, is based upon a careful study and comparison covering many years, showing the relation between railway purchases and general business.

The results of this careful and detailed analysis are presented at this time in the hope that the painful experience with which the country is afflicted and further threatened may yield us at least the dividend of knowledge upon which to base future national policies. Indeed, it has an immediate and urgent bearing upon a policy which the government is at this moment engaged in formally considering. If the conclusions drawn from past

Not many years ago, comparatively few business men, aside from those directly selling to the railways, realized that railway prosperity meant general business prosperity.

The past few years, however, have witnessed a steadily growing recognition of this fact on the part of business men generally, until today it is substantially an accepted doctrine.

There is wide-spread confusion, however, as to what constitutes "railway prosperity," often the result of the popular error of accepting the increased earnings of some particular railway, or the naturally growing gross earnings of railways generally as proclaimed by the public press, as being indicative of "railway prosperity." Much is now being written regarding decreased net earnings and the many other evidences that the railways generally are by no means prosperous in the true sense of the word, or as determined by the true tests applicable to all business enterprises.

It is believed that the watch-word "Railway Prosperity means General Business Prosperity," should be changed to read: "Railway Purchases measure General Business Prosperity."

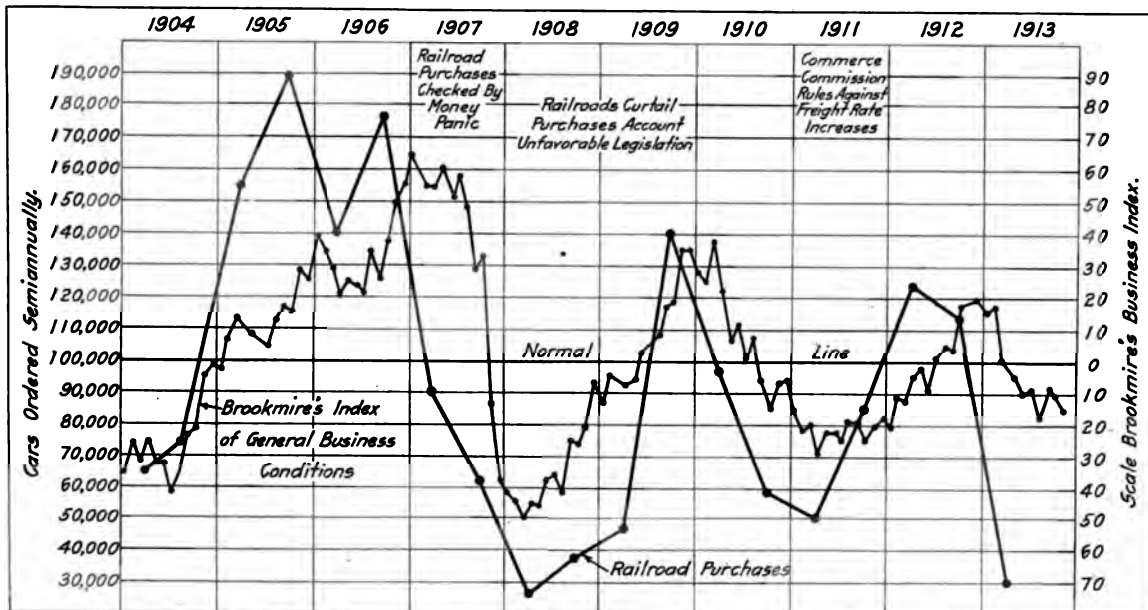

Chart Showing Relation of Railroad Purchases to General Business Conditions.

experience are correct, and if even the small advance in freight rates now asked for by the eastern railroads would enable and encourage them and other roads to make considerable outlays at once, such an outcome would directly result in a decided restoration of general business activity.

It is not for a moment proposed that railways shall be permitted advances in rates in order that unnecessary purchases may temporarily benefit the railway supply industries, or even the whole country. Waste never permanently benefits anybody. It is not unnecessary purchases which are under discussion. Railway facilities are insufficient to meet any considerable increase in tonnage. The proposition is not to over-stimulate but to remove an artificial restriction, in the shape of rates too low.

The greatest danger at this moment is delay. It is well recognized that it requires a greater force to start from inertia than to continue a momentum already established. The sooner the commission can issue a favorable decree the more certainly will the influencing power of railway purchases be effective in the restoration of general business.

Inasmuch as the railways of this country constitute its greatest industry next to that of agriculture; with but one thing to sell—transportation: the ultimate consumers of everything they buy: their purchases extending substantially throughout almost every department of business: many of them on a tremendous scale—it must be obvious how potent a factor they are in general business conditions.

As the iron and steel industry has long been recognized as being the truest index of general business conditions, and as the statement has been reliably made that the railways consume, directly and indirectly, between 40 and 50 per cent. of the iron and steel production of the country, it is manifest that the expansion or restriction of railway consumption must vitally affect this barometer.

The ramifications of railway purchases make it impossible to classify them in the aggregate. But few of the more important items, such as rails for example, are made the subject of public information and statistical compilation. However, the conditions under which rail purchases are made are not believed to be such as to reflect the railways' prosperity, or their purchasing ability, in a broad sense.

\*An address at the annual meeting of the Railway Business Association, New York City, December 11, 1913.



Many years of observation have led to the belief that of those items officially compiled, tabulated and made public, perhaps no one so clearly and typically reflects the railways' general purchasing ability as that of new equipment. When the railways are buying freely of new equipment, they are generally likewise buying freely of all other articles essential to maintenance and operation. Within the past few years the purchasing of new equipment has had a greater influence upon the iron and steel industry because of the transition from wooden to steel construction.

One branch of the writer's business being that of making and supplying a necessary article used on railway car equipment, he has been led to make a close study of the effect of railway purchases of new equipment upon general business, and long since became more than convinced that there was no one more important factor in the development of general business activity than that of the active purchasing of new equipment by the railways. He further fully believes that railway equipment purchases, with naturally attendant influence upon the great volume of other railway purchases, not only *initiate* general business prosperity, but are necessary to *sustain* such prosperity.

It has been observed for many years past that the railway supply industry has been the first to recognize, and to participate in a revival of *general business*; likewise the first to detect the signs and feel the effects of its impending decline.

It is well known in many quarters that since 1907 railway purchases have been affected (and in large measure curtailed) by causes other than those which influenced them in preceding years, chief among these being governmental control and restrictions.

It has, however, become quite apparent that since the year 1907 "railway purchases" as a factor in general business conditions have been evidenced with increasing clearness, and brought into more prominent notice by those who attempt to follow the trend of general business.

Reviewed by years, and since what is known as the "money panic" of 1907, we find the following conditions:

1908.—The year 1908 was notably the leanest of business years, notwithstanding bountiful crops and plentiful money. It was likewise the year in which the smallest number of cars were ordered, namely, 62,999, and the minimum of railway purchases made for many years.

1909.—The conditions of 1908 were continued well into 1909, but the last half of the year witnessed a substantial buying movement by the railways, the total cars ordered for the year aggregating 193,874, nearly 70 per cent. of which, however, were ordered within the last four months, with particularly heavy orders in November and December. This gave a fairly good business year, with a heavy "carry over" in 1910.

1910.—General business promptly followed, and with the heavy "carry over" business from 1909 referred to, coupled with fairly good buying on the part of the railways during the *first* six months, made the year 1910 a still better year than 1909, although the total of car purchases was only 145,085. The falling off in car orders after the middle of the year was duly reflected in the decline of business until at the end of 1910 the probabilities of 1911 were clearly foreshadowed.

1911.—The decline in general business, together with the falling off of railway purchases continued throughout almost the entire year; but at its close a buying movement on the part of the railways set in. The total number of cars ordered for the year was 135,740, nearly 30 per cent. of which was placed at the very end of the year, and necessarily carried forward into 1912.

1912.—We reached a high point in railway purchases about May, 1912, continuing with normal purchases for most of the remainder of the year, again reaching a high point at the very end of the last quarter, the total car purchases being 238,400, the largest number in any year since 1906. It is here significant

to note that the foregoing conditions in railway purchases were followed by a phenomenal revival of general business during the last half of 1912—this, too, in the face of a national election fraught with more uncertainties as to its outcome than any we have had for years. Business seemed to ignore these conditions, however, while the heavy purchases made by the railways filled the steel mills of the country with orders toward the close of the year, so overtaking their capacity as to compel buyers to anticipate deliveries by orders placed four, six and even nine months in advance of shipping dates—a condition heretofore unprecedented—while general business assumed almost the aspect of a boom.

1913.—The heavy purchases of new equipment continued during the first three months, but sharply declined at the beginning of the second half of the year—almost immediately sinking to the lowest level reached these several years. It was here that the "danger signal" was set by this barometer; but naturally general business did not immediately feel this falling off of railway purchases at the time (because of the accumulations) nor in fact until quite recently, being sustained by the "unfilled orders" on hand, or what may properly be termed the "unspent momentum." The conditions clearly foreshadowed at the middle of the year, and accentuated every month since, are now upon us, and what have we to look forward to after January 1, 1914? If the railways do not resume purchasing on a fairly liberal scale, we are certainly facing a very depressed business situation.

It is believed that the great majority of business men have failed to recognize the real situation, and that the now noticeable decline in business is being attributed to other causes.

Had the railways been granted the 5 per cent. advance in freight rates which they sought last June, it would not only have restored great confidence in railway credit, but would undoubtedly have been followed by a buying movement which, if on but an average scale and within the limitations of money conditions, would have so far reinforced the large volume of "unfilled tonnage" as to have obscured the several now existing uncertain elements, just as these same elements (when in prospect) were practically ignored during the latter part of the year 1912 and the early part of 1913.

The illustrations given above are believed to be sufficiently significant, if not conclusive. They may be carried back over any number of years, and with the same result shown. Is it merely coincidence, or is it cause and effect?

While financial or money conditions are essentially fundamental to "railway purchases" as well as to every business enterprise, nevertheless, anything which affects "railway purchases," be it lack of money, inability to secure it on favorable terms, or unwillingness to use it, must work to the same common result.

If the iron and steel industry, heretofore broadly recognized as the great barometer of general business conditions, and as basic to them, is dependent upon "railway purchases" to the extent of the absorption of 40 to 50 per cent. of its production, how much more really basic are "railway purchases" as the initial force in starting and sustaining the circulation of general business? Are they not manifestly the pulse of general business?

It is confidently believed that the sooner this country, as a whole, recognizes this basic relation of "railway purchases," the sooner we will deal intelligently with this controlling factor.

In conclusion, one prominent thought is urged, namely, that it is not the railway supply industry alone that is so vitally affected by "railway purchases," as generally supposed. From its nature, the railway supply industry is logically the first to feel their effects; but every business interest, every business man, large and small, and all those dependent upon them, are each in turn affected, favorably or unfavorably, by the relation undoubtedly existing between "railway purchases" and "general business prosperity."

**CANADIAN PACIFIC ALL-STEEL TRUCKS.**

Within the past few years a number of railways have adopted all-steel trucks for service under heavy passenger train equipment. The Canadian Pacific has in use a type of four and six-wheel steel truck that was designed by the general master car builder, R. W. Burnett. The general appearance of the two trucks is clearly shown by the illustrations from photographs, while the details of the construction of the six wheel truck are illustrated by the line engraving.

One of the points about the truck that at once attract attention is the smooth straight line external appearance with the omission of the usual end pieces. The absence of the end pieces gives a better clearance for the car steps and allows a better op-

are made of flat plates which are first punched approximately to shape, and then milled to the exact size. In designing the truck, it was expected that these pedestals would bend in case of a derailment, but that they could easily be bent back again into shape. Experience, however, has shown that whenever a derailment has occurred the pedestals have not been distorted and it has been possible to carry the car body to the shops on its own trucks.

For wearing strips, chilled cast iron liners are riveted to the jaws, and these have shown wearing qualities superior to anything else that has been tried. Neither liner nor box has yet shown any appreciable wear and the indications are that both will run indefinitely. At the bottom, the jaws are tied together by a short pedestal tie bar held in place by a pin, fitted with cotters and without bolts or nuts. To remove a pair of wheels,



**All-Steel Six-Wheel Truck for Passenger Equipment; Canadian Pacific.**

portunity not only to strengthen the draft rigging but to inspect and maintain it. On the end toward the center of the car there is a better opportunity to install the axle light apparatus.

The side beams consist of two 8 in. channels, with their flanges toward each other. They are riveted together with spacing blocks between so that they present a smooth surface on the outside. The two beams thus formed are tied together by Z bar transoms and straight gusset plates extending all the way across the truck of both the top and bottom of the channels. At the pedestals the lower flanges of the channels are cut away to admit the equalizers and are, at the same time, stiffened by the pedestal plates. These

all that is required is to take out two cotters for each pair of wheels, pull out the pins and lift the frame.

The absence of the end pieces necessitated the use of inside hung brake beams, and these are installed without any retracting springs, but with a special brake beam adjuster. This is very clearly shown in the enlarged end view of the six-wheel truck. It consists of a hanger carried by arms riveted to the transom. Into the bottom of this hanger is screwed the carrier that supports the truss of the brake beam. No check nut or cotter is required to hold it in place, as it cannot turn and the adjustment is effected by removing the pin from the brake beam, screwing the carrier to the proper position and replacing it in the beam.

Bolts and nuts are avoided and one of the arrangements for



**End View Showing the Brake Beam Adjuster and the Absence of the End Piece.**



**Four-Wheel All-Steel Passenger Truck.**

doing this is to be found in the bracket for the spring plank hangers. It will be seen that these are on top of the gusset plates. They are simple castings with a seat for the hanger pin. This pin is held in place by a wall over the hole at one



end and a cotter pin put across the hole at the other end. To remove the pin, a hole is left in the wall, through which a drift can be pushed or driven.

In spite of the substantial appearance and actual strength of these trucks they are lighter than the composite trucks which they replace.

## GOVERNMENT OWNERSHIP AND THE RAILWAY EMPLOYEE.\*

By J. K. TURNER.

The ringing chorus of "Safety First" has now filled the ears of America's army of railroad men for several years. What is the meaning of "Safety First" to the railroad man? First, his life, health, and comfort. Second, his job. The railroad employees of the country have recognized the first meaning of "Safety First." But they have forgotten the second.

If "Safety First" means anything to the American railroad employee, it means not only the safety of his life, his body, his home, his comfort, but it means the safety of his job.

The railroad man stands today in peril of losing the freedom of action which has hitherto been such a marked characteristic of his place in the industrial scheme of things. Why? Because the railroads of the United States are today on the brink of government ownership, a condition which would sweep out of the grasp of railroad employees the broad liberties they now possess.

The biggest question before all railroad employees of all railroads of the country to consider now, before it is too late, is this: Do you want government ownership of American railroads?

For years, government ownership has hung in the horizon's mists—to some a gleaming light of hopeful promises, to others a cloudy star of menace.

Today you can no longer dismiss the thought of government ownership with light unconcern. The crisis is here. You stand at the parting of the ways. Which way shall it be? Some railroad heads predict government ownership within a year. All declare that it will come quickly unless the present trend of affairs is decisively headed off.

Contrast the lot of the railway mail clerk, a government employee, with that of the trainman, an employee of private management. The comparison will throw searching light upon the subject.

The railway mail clerk starts at a minimum wage of \$60 a month. He is often required to work long after his regular hours. He receives no pay for overtime. His hours often average twice those of the trainman. The mail clerk is under civil service regulations, and is required to take frequent examinations on new routings, new territories, and the like. He must prepare for these examinations while off duty. He must take these examinations on his own time. Mail routings are changed with great frequency, thus upsetting the value of his previous knowledge, and requiring intense application and high pressure study to master the details of new routings.

A foreman of railway mail clerks is paid \$150 a month. Promotions beyond this position are very difficult for a mail clerk to secure. The higher positions in the service are almost entirely politically appointive.

And finally, railway mail clerks are not permitted to organize for the purpose of bargaining with their employer direct for wage increases or for bettering their working conditions. They may only take the matter up with their congressmen, an act of Congress being imperative before any changes can be effected. Nor may government employees strike, no matter what their grievances. To strike under these conditions is treason.

Remember what happened in France. The government took over the railroads, and incidentally made all railroad employees

part of the national guard. In time, M. Briand, himself a labor leader, became France's premier. The railroad men got into a squabble with the government, and went on strike. Premier Briand was forced to put rifles into the hands of the strikers, thus turning the strikers themselves into strike breakers.

Consider, in turn, the lot of the trainmen under private ownership of American railroads. The eastern trainmen, under the new wage ruling, start at minimum wages of \$78 and \$76.50, the former figure applying to rear brakemen, and the latter to others. These figures are exclusive of overtime. Overtime rates are 26 and 25½ cents per hour respectively for these classes of service. Overtime is allowed after eight hours of work within 12 hours. Lay-overs of less than one hour are not deducted.

Under the present system, railroad employees may bargain direct with the employer as to wage increases, better working conditions, and the like. The grievance committee has the privilege of going direct to the officials at any time with any grievance whatever. There is no red tape to involve delays. For back of every grievance, every wage request, every request for improvement of conditions is the banded power of an army of workmen, standing firmly on the platform of collective bargaining.

Time and again we have beheld the successful culmination of railroad employees' demands, even in the face of greatest odds.

We have seen repeated wage increases for railroad workmen, while at the same time the Interstate Commerce Commission refused the railroads the right to advance their rates slightly.

The power that won for the banded employees their demands can remain a living force, however, only so long as private management of railways exists.

Let government ownership come, and immediately banded railroad labor's strength will vanish in the twinkling of an eye. And if the government then decided to place trainmen's pay on a par with that of its mail clerks, the trainmen would have no redress, save that of carrying their grievances to Congress. And once such grievances got tied up in the red tape of congressional action, none can tell what the outcome would be.

Does the railroad man regard his chances for comfort of mind and stability of position as better under the present system than it could be under government ownership, or does he believe that the reverse is true?

Under present conditions, the country is suffering from hardening of the arteries. The paralyzing effect of this condition is beginning to be felt severely. It must be headed off. The railroads, having been refused permission to economize to fit their pocketbooks, are in direst need of the small rate increase they request. Otherwise they will fall farther and farther into the state of obsolete inadequacy which is laying hold of the tools of the country's commerce.

You may say that it is no concern of yours if the Interstate Commerce Commission sees fit to deny the railroads the rate advance. But it is a very vital concern of yours. Its denial will mean government ownership just that much closer. It will overtake the weak roads first and the strongest roads eventually. There will be no escape.

Railroad labor and its minor officials will be the first to suffer under government ownership. The railroad heads have much less to worry about. For their experience and ability will win them managerial positions on the railroads under the new order.

Railroad heads are worrying not for themselves, but for the men lower in the ranks. They are responsible for your welfare. They have the keenest anxiety for your future, your comfort, your happiness, and your homes. You may not believe this. If not, it is only because you have never been an employer of labor. If you ever become one, this statement will come back to you. You will then understand its truth.

Talk to your banker and storekeeper. Ask them what they think they can gain under government ownership of railroads. Perhaps they are complaining of shipping conditions as they are

\* Abstract of an article in *The Mediator*.

today. Yet will conditions not be far worse under government ownership?

Inadequate as are the railway facilities of our own privately owned railroads, are conditions as bad as in England, France, Germany, and New Zealand, under government ownership? It is reported that in New South Wales, the proportion of gross receipts carried to the surplus account fell from 12.97 per cent. in 1907 to 2.77 per cent. last year. Does that indicate good management?

Again, the net return on capital invested in Australian government railways last fiscal year fell to 3.56 per cent., against 4.09 per cent. in 1912, and 5.22 in 1911. Does this indicate that government ownership of railways is successful in that country?

France, Germany, and England, with their government owned railways, have faced increasing lack of adequate facilities ever since the new order became effective. The red tape that surrounds railway officials and binds the whole systems is abhorrent to the American ideals of facility and despatch.

But it is argued that this is America, and that government ownership would be a very different story here. Let us see. Did you ever have a new post office building constructed in your vicinity? Did you observe how much longer it took to build than the privately built edifices? Wasn't it true that by the time the post office was completed it usually turned out to be too small for the requirements? Was this efficiency? Was it good business? Would a private business man have tolerated the delays and wasteful expenditure, such, for instance, as building a four-story federal building in a two-story town?

When election day came around again, didn't you hear your congressman boast that he got the government to spend the lavish sum the post office building cost? Hardly a congressman but has made these boasts, demanding re-election in return for the government's money he succeeded in squandering.

In Washington you may see numerous government offices installed in rented office buildings of ramshackle and unsafe construction, simply because some landlord has enough official influence to rent the government such premises at an extravagant figure. Is this efficiency? Is it good business?

And yet the government is honeycombed with these practices. And now it makes the inferential threat that it will take over the railroads and attempt to run them, that it will take them away from railroad managers who have devoted their lives to the profession of railroading, men who, coming up from the very bottom in most cases, have been trained under the sharpest and intensest competitive conditions into capable and proficient railroad managers, and that it will turn them over to a lot of politicians to run!

For these reasons every man on every railroad should do his share to discourage government ownership of railroads. He should talk to the people of his community, in the stores, shops, streets and homes, where public opinion is made.

Every railroad man should constitute himself a committee of one to talk to his butcher, his grocer, his baker, about these matters. He should talk to the editor of his newspaper, to his preacher, doctor, lawyer, dentist, mayor, and alderman. What these people think and say makes public opinion, the most powerful force in the history of all the world, and the only force that can save this country from a calamity like government ownership of its railroad arteries.

It is the business of railroad employees of every rank at this time to inform that portion of the public nearest them what railroad baiting means. It means tightening of trade, credit, and prosperity, and none can escape the harm. It is a community question. Its effect falls upon every inhabitant of the country.

Ask your banker who is the best depositor of savings—the government employed post office clerk, or the trainman, engineer, or fireman of the privately owned railroad?

Who is the better citizen—the post office clerk, or the railroad man?

Who is worth more to the community—the postmaster or the division superintendent of a railroad? Does not the former hold his position by dint of political influence, while the latter got there by hard, intelligent and faithful service alone?

And observe, if you are a railroad man, that in case of injury in your work, should government ownership come, you cannot sue the government, without the government's consent. Inform your community that neither could a traveler, hurt in a wreck, sue the government for damages without the government's consent.

Who ever heard of the government establishing for its employees old age pensions, workman's compensation, and similar benefits? True, the politicians will promise all these things. But how many politicians' promises, in your experience, have you seen kept?

The argument, in short, is overwhelming in favor of private ownership, with proper regulation, of our railroads. They are fighting a hard fight. They need your help. It is to your personal interest to save the railroads from government ownership. You have a definite part to play in bringing the sober judgment of the country to assert itself.

Government ownership would be a wasteful experiment. Undoubtedly private ownership, after a few years, would be again in universal demand. In view of the world-wide present demand for capital, the nation's credit would be found insufficient to meet the pressing demands from every part of this large and growing country to improve living and agricultural conditions, foster commerce, and meet the demands of progress.

Strict and intelligent state and national regulation, under private ownership, can and must solve the problem. Government ownership would be purely punitive, and punishment costs terrifically and yields no proportionate returns.

Railroad men, the time is here for you to act. Start creating sober, intelligent public opinion today.

**MANCHURIAN RAILWAY CONSTRUCTS SILK FACTORY.**—The South Manchuria will have completed, before the end of the year the construction of a tussah filature, or raw silk reeling establishment, and a dyeing and weaving factory. The latter will start with a force of trained Japanese and Chinese workmen. Weaving by hand, which is usual in China and Japan, will be tried first, but the importation of modern machinery is now under consideration for inclusion in the estimate of the railway expenditure for the coming fiscal year. About \$15,000 worth of wild silk cocoons have already been purchased for use at the filature during the ensuing year, and \$35,000 worth of tussah silk has been purchased from other filatures for practical experimental purposes.

**BRITISH RAILWAY CONSTABLES AND TRADE UNIONS.**—An important question has arisen between the London & Southwestern and certain of its railway police, as to whether they shall be allowed to join the National Union of Railway men, and the matter is still under discussion. It appears that about 60 constables have joined the union with the object of improving their conditions of service. Their position is somewhat peculiar, as they have sworn to preserve the peace, and the company's attitude is that if the constables belong to the union and a strike or disturbance arises in which union men are engaged, it will be difficult for them to carry out their oath. Again, if a strike were declared by the union these constables would in all probability have to go out with the others. The company has accordingly pointed out that if the men persist in their union membership they must be transferred to some other branch of the service. The constables declare that they have never discussed the question of going out on strike, and that they had not attempted to raise the question of wages. Their complaint refers mainly to the hours of duty, and they maintain that they have only joined the union as a measure of self-protection.

# NEW DEVICES FOR THE CAR DEPARTMENT.

## Link Side Bearing Used With a Bolsterless Truck—A Coupler Release Rigging—A Collapsible Stake Pocket.

Details of freight car design are receiving more and more attention; the three devices described in the following article reflect the variety of the designs which are being suggested and, to some extent, the refinements to which the work is being carried in the effort to secure the greatest possible efficiency from the equipment.

### LINK SIDE BEARING TRUCK.

It has frequently been claimed that the principle of transferring the weight of a car to the trucks through a loaded center plate is wrong, and that it is useless trying to balance a load of 100,000 to 200,000 lbs. on two central points at each end of the car. This

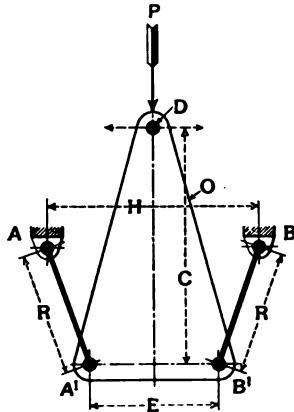

Fig. 1—Diagram of Link Side Bearing.

has led to the design of trucks which support the load of the car by links or similar construction on each side frame.\*

Fig. 1 illustrates the general principle of a link motion device of this type that has been designed by A. Stoikowitz, of Montreal, Que. *A* and *B* represent fulcrum points for the links *R* which support oscillator *O* at points *A'* and *B'*. Point *D* will travel on a straight line, when certain approximate proportions between the dimensions *R*, *H*, *E*, and *C* are met. The movement of point *D* denotes the side bearing travel which is comparatively small, and as the angular movement of the pivot points is correspondingly small and lever *C* is greater than *R*, the frictional resistance resulting from these points will be small and can be safely neglected. As the load is being carried on what might be called a floating support, the oscillator *O* provides for a nearly frictionless horizontal and radial truck movement on a curve (Figs. 2 and 3), while the links or hangers *R* also allow sufficient lateral movement of the car body, as is the case in a swing motion truck. Furthermore if *D* is pivoted

\*For description of the Summers side bearing truck, see *Railway Age Gazette*, March 22, 1912, pages 677-680.

to its fulcrum by a pin, it will form an effective anti-telescoping device, as, in case of an accident, it will prevent the cars being lifted from their respective trucks.

Fig. 2 shows the application of this device to a six-wheel passenger truck; the oscillator is U shaped and straddles the side bearing arch as shown; the hangers are of the solid link type and engage both the oscillator and the side bearing arch. The anti-telescoping feature is applied by pivoting the top of the oscillator to the side bearing fulcrum by means of a 2 in. pin. This pin is under double shear and would require an enormous force to tear a truck from its body, provided all the details involved are of equal or greater strength.

Fig. 3 illustrates a standard arch bar truck with bolsters and

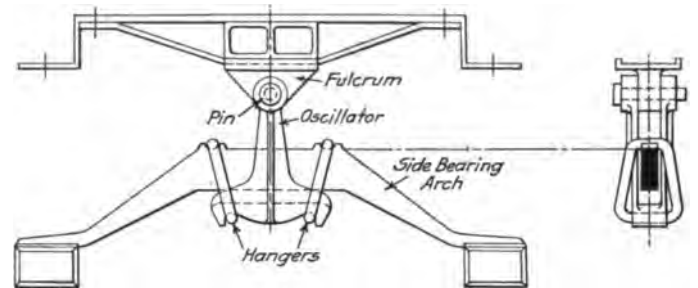

Fig. 2—Application of Link Device to Six-Wheel Truck.

center plates eliminated and the entire load carried by the side bearings only. A truck swivel plank is substituted for the bolster to provide a swivel point for the truck center. The side bearing fulcrums are riveted to the swivel plank and placed over the truck springs, which arrangement transmits the load directly to the side frames. The king pin hole in the swivel plank is slotted to allow a lateral movement of the car body on the link hangers, thereby embodying the general features of a swing motion truck.

Fig. 4 shows the application of this link motion principle as an ordinary side bearing, which is secured to the truck bolster and intended to replace the common plate or roller side bearing. As dirt has no effect on this side bearing the design can be entirely open; in fact it admits a great variety in the construction of hangers, oscillator or base, depending on the conditions.

In order to prove the theoretical correctness of a bolsterless truck, Mr. Stoikowitz analyzes three cases to which any truck bolster is subjected caused by the different conditions of service. Referring to Fig. 5, there is a clearance between both side bearings; the load is being carried by the center plates only. Undoubtedly this case requires a bolster capable of supporting a concentrated load *P* at its center and should be sufficiently rigid

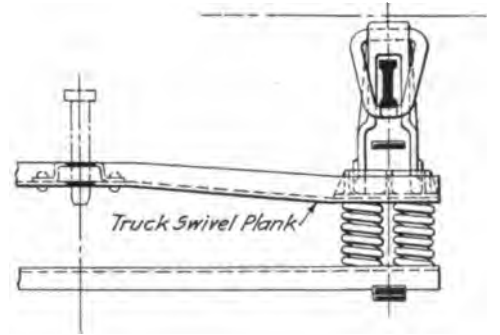
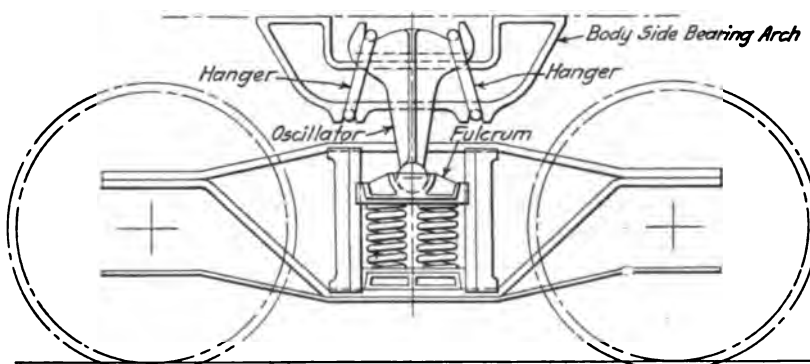

Fig. 3—Standard Truck with Weight of Body Transferred Through the Side Bearings.

to maintain clearance  $F$  under all conditions of service. As this clearance will vary from  $\frac{1}{8}$  in. to  $\frac{1}{2}$  in., it is evident that the rocking motion of the car body is directly proportional to twice this clearance, which will produce an unfavorable pounding action on side bearings and truck springs.

Fig. 6 represents a common condition to be found on cars after they have been some time in service and illustrates the obvious uselessness of a bolster strong enough to support a concentrated load. There is no clearance between side bearings, the body bolster or both, by defective center plates or by many other causes. Evidently this case fails to make use of the total carrying capacity of the bolster in a proportion, as the central force

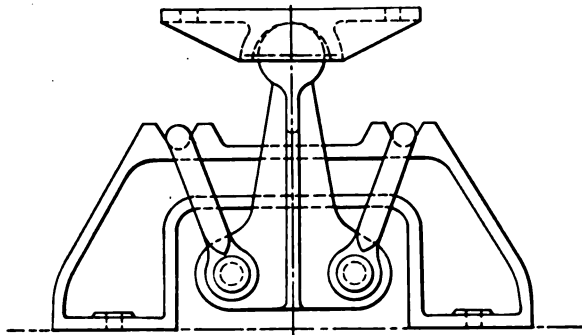

Fig. 4—Link Principle Applied to Ordinary Side Bearing.

$A$  decreases and the two side forces  $B$  increase. As the distance  $E$  is small compared with distance  $D$ , and considering the worst case of  $B = \frac{P}{2}$ , the resulting bending moment for this point,

being  $\frac{PE}{2}$ , is very small as compared with the bending moment

in Fig. 5, which is  $\frac{PL}{4}$ . But as there is no clearance between

the side bearings, the rocking tendency of the car body is greatly retarded or absorbed by the truck springs.

Fig. 7 shows the load unequally distributed and has the same general properties as Fig. 6, with the additional disadvantage of compressing the truck springs unevenly; that is, reaction  $R_1$ , will be greater than reaction  $R_2$ . It has been attempted by the use of some cradle arrangement to throw a proportionate part of the load toward the light side, but the theoretical correctness of such an arrangement is questioned; the only remedy is equal distribution of load.

Fig. 8 represents the idea of supporting the load directly over the truck springs, thus eliminating truck bolsters and center plates. As there is no side bearing clearance, the rocking tendency of the car body and the resulting pounding action are greatly retarded. With the load unequally distributed it is equivalent to the case shown in Fig. 7 in compressing the truck springs unevenly, but this condition will happen in exceptional

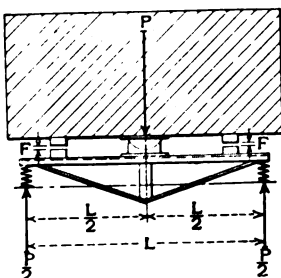

Fig. 5.

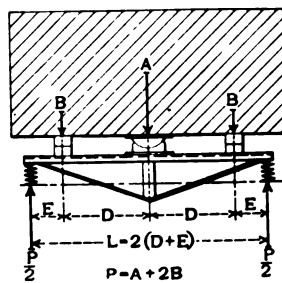

Fig. 6.

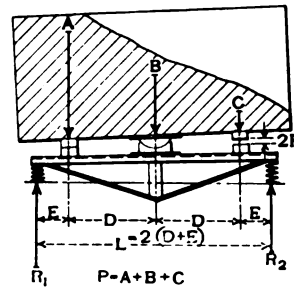

Fig. 7.

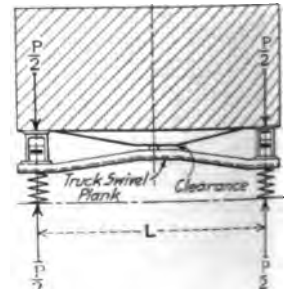

Fig. 8.

cases only and will have no appreciable effect upon this bolsterless truck.

Some of the general advantages claimed for this link side bearing in connection with a bolsterless truck are that it solves in a simple manner the side bearing problem, and that when applied to freight trucks it will reduce the dead weight of each car and reduce the wheel, flange and rail wear with a corresponding decrease in draft resistance and chance of derailments. When applied to passenger equipment, it gives a nearly frictionless side bearing combined with an anti-telescoping device.

Patents have been applied for on this design by A. Stoikowitz, Montreal, Que. It is manufactured by the Link Side Bearing Company, 314 Hammond building, Hammond, Ind.

**COUPLER RELEASE RIGGING.**

The release rigging shown in the illustrations employs a minimum number of parts to operate the uncoupling mechanism of an M. C. B. top lift coupler. This device consists of an operating lever of 1 in. round bar, bent to the shape shown, and two malleable iron brackets riveted to the end sill. The side movement of the lever in the eye of the coupler lock and the draft gear movement by the slot in the bracket located nearest the coupler,

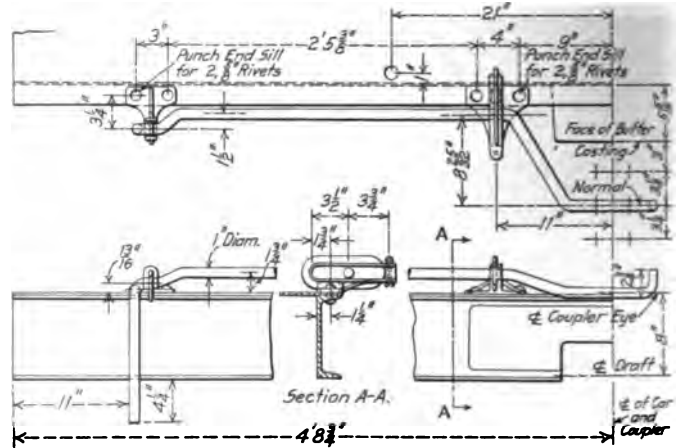

National Coupler Release Rigging.

with the outer bracket acting as the center of rotation. When releasing the coupler by hand, the operating lever rotates in the two brackets and the movable bearing in the inside bracket allows an adjustment so that the coupler lock is lifted at the angle which is the best suited to the particular type of coupler being operated.

It will be seen that the lever has a three point bearing, viz.: in each of the two brackets and in the coupler lock eye. This obviates the necessity of setting the lever handle back against the sill face to prevent sagging of the reach arm and makes it possible to design the lever with a good clearance between the handle and the sill face. In this way the handle is allowed to accommodate itself, in the case of interchange coupler applications, to the difference in the height of the eye of the coupler lock as well as the cases where the coupler sags from its original position.

It will be noticed that the lever has a limited movement in this bracket so that an abnormal forward movement of the coupler, as in the case of the coupler becoming detached from the draft gear, will result in the lever tending to unlock the coupler and release the adjoining car, preventing the coupler from being entirely pulled out of the end sill and falling to the track.

It will be noted that the lever is simply a 1 in. round steel bar from end to end, bent to fit the particular car to which it is applied. In case it becomes distorted in service, the removal of the two cotter pins which hold the lever in the brackets will allow it to be disconnected from the car. By using the lever on



Coupler Release Rigging on a Hopper Car.

the opposite end of the car as a pattern, it is an easy matter to bend it back to its original shape without the use of any special dies.

There is a slight offset in the operating lever near the outside bracket which holds it in the same position laterally at all times, thus insuring the desired amount of forward and backward movement within the slotted bracket.

This rigging is manufactured by the National Railway Devices Company, 490 Old Colony building, Chicago, Ill.

#### IMPROVED STAKE POCKET.

A new stake holding device for freight cars has recently been developed by the U. S. Metal and Manufacturing Company, New

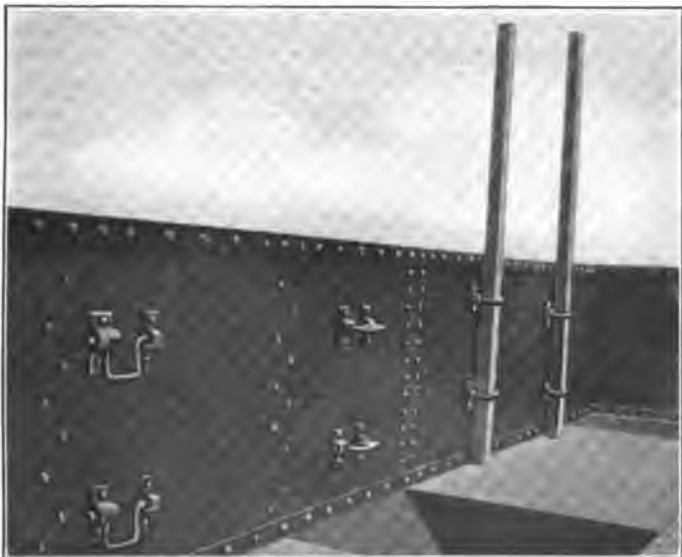

Collapsible Stake Pocket Applied to a Car.

York. The device can be applied to a car in the position where the strap or cast pocket is now attached. The advantages claimed for this type of stake pocket are, that when not in use it drops to the side of the car, thereby increasing the inside width of the car for such forms of lading as lumber, structural shapes, piping, pig-iron, etc., and it also prevents damage to the pockets or lading in loading and unloading. When loading material which requires stakes, the pockets are raised to a horizontal position and moved to the rest lug on the right, after which the stakes are applied. The pockets are strong, of simple construction and always available for stakes of M. C. B. dimensions. A large percentage of the old type pockets are constantly out of repairs; they are expensive to maintain and facilities for repairs are not provided at loading points, resulting in improperly applied stakes or the use of stakes that do not meet M. C. B. requirements. It is claimed that the breaking load of the stake over the round section of this pocket is 18 per cent. greater than that over the square edge of the strap pocket. The round section also makes the driving of the stake easier, as well as more secure. The pockets have been thoroughly tested out in actual service for over a year with excellent results.

#### YOUNG LOCOMOTIVE SUPERHEATER.

Following the lines of simplicity generally found in American locomotive design, a new fire tube type of locomotive superheater has been designed which eliminates a number of the parts generally found in the designs now in use. It is so arranged that any required number of double loop pipes may be entered in the enlarged boiler flues set in a horizontal row across the upper two-thirds of the boiler in accordance with the practice which has developed the highest degree of superheat for the smallest amount of superheating surface. The two ends of each individual unit are connected to a steel plate header located near the top of the front end and integral with the front tube sheet, by an expanded joint in the same way that the boiler tubes are joined to the front tube sheet. This header has two compartments, one for saturated and the other for superheated steam and one end of each unit connects to each compartment. The entire superheater is encased in a steel plate box provided with a damper in the bottom to divert the gases from the superheater portion as desired.

This construction provides for a superheater which is integral with the boiler, and is applied and maintained by means common to boiler construction and may be properly maintained by a class of labor skilled only in boiler work. There are six features of special interest to be noted in this construction. These are the use of a small steel plate header of the drum type which does not require the use of stays; the connecting of the ends of the unit pipe to the header by means of the usual tube expanded joint; the substitution of welded return bends at the ends of the loops in the unit pipes for cast steel return bends; the arrangement of units so that any one can be removed with the removal of but one other if in the upper rows and no other if in the bottom rows; the construction which permits the removal of the dry pipe without disturbing the superheater header or units, and the arrangement for tightening the unit pipes to the header without disturbing any of the front end apparatus or appliances.

The header is in the form of a drum and is secured in place on the front tube sheet in the location occupied by a tee head in a saturated steam locomotive. It has a steam tight connection to the end of the dry pipe as is shown in the illustration. The plate dividing it in two compartments is welded in place and contains an opening or manhole of a size to permit the dry pipe to pass through it. This opening is closed by a specially constructed sealed cover, which can be removed when the tee head has been taken down. There is a reinforcing plate at the front face of the drum and the tee



head connects to it with a ground joint of the usual type. The tee head is arranged for connections to the steam pipes which lie in a vertical plane parallel to the center of the boiler and will allow the removal of the head without disturbing the lower connections of the steam pipes. The holes in the bottom of the header for connection to the unit pipes are formed the same as the boiler tube holes in the front tube sheet and the unit pipes are connected to them in the same manner as boiler tubes by means of a Prosser or roller expander. Beading, of course, is not necessary, as there is but little tendency for them to pull out and it is only necessary to make a steam tight joint. There are hand holes in the upper part of each of the compartments, that are closed by a special type of hand hole plug which can be inserted from the outside and is sealed by a copper gasket or ring. This type of plug has been in successful use on superheaters in stationary practice for many years. Above the whole header a section of the front end sheet is cut out and fitted with a removable cover plate which will give access to the top of

and it is also possible to remove unit pipes from either of the top rows by the removal of one other unit. If a unit is removed by cutting off, the slight loss in length is made up by changing the position of one of the bends slightly. This can be done cold without damage to the pipes. The flue pusher method of removal, however, is to be preferred.

In place of using cast steel return bends with the unit pipes screwed or welded in place, this design employs a welded joint between the two sections of pipes. This joint is made by first bending the ends of the pipe to an angle of about 45 deg. and then sawing them off on a line parallel to the axis. These two parts are then brought together and electrically welded. This construction is used at all of the return bends.

The damper operating mechanism is of the customary form which closes the damper by means of a counter weight when the throttle is closed and opens it only by steam pressure on the opening of the throttle.

Removable plates are arranged in the front of the damper

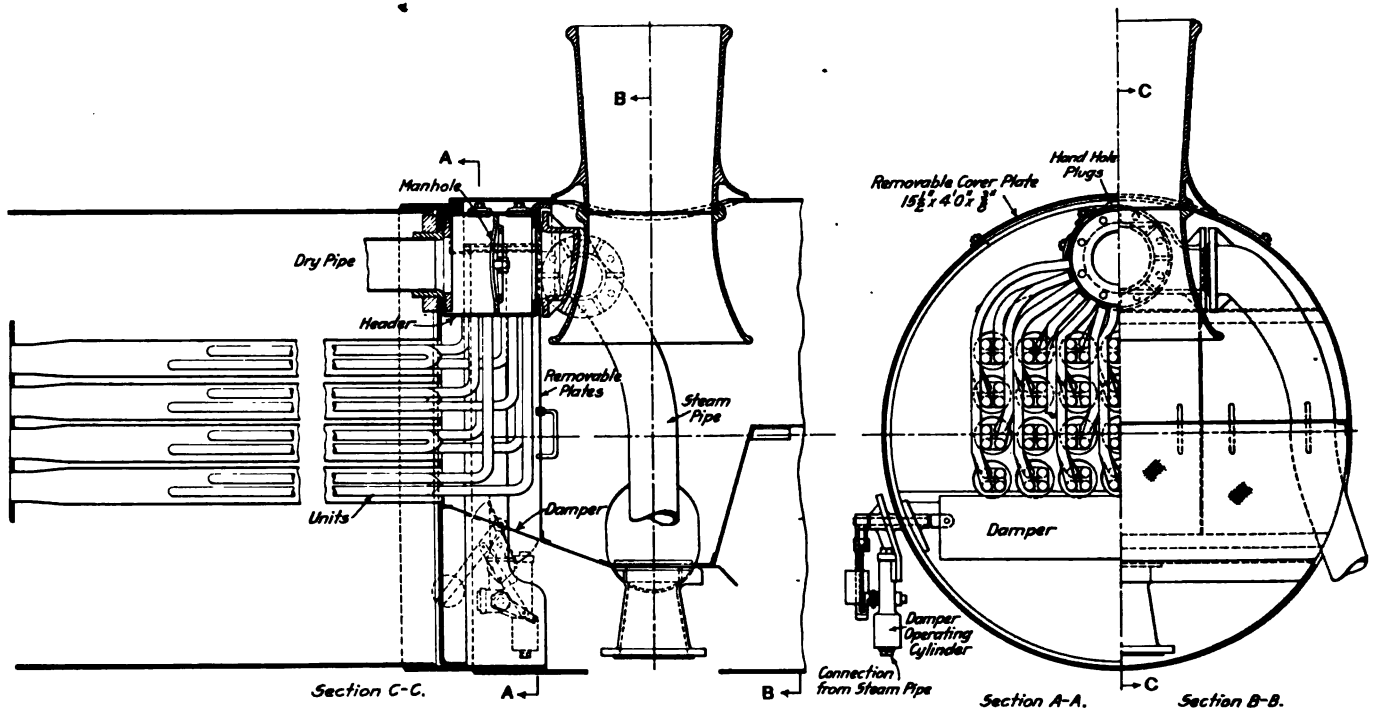

Sections Showing Small Header and the Arrangement of the Units of the Young Superheater.

the header from the outside of the locomotive. In addition to the hand holes in the upper part of the header there are also small openings diametrically opposite the entrance of each of the unit pipes. These are closed with a small plug, of a design similar to the special hand hole plug already referred to.

The method of inserting a unit is to remove one of the hand holes and the small plugs from the openings directly opposite the two joints. A Prosser or roller expander is then inserted in the hand hole and properly placed and an extension is inserted through the small opening and connected to the roller. An air drill or hammer can then be used on the outside and the joints properly made.

When it is necessary to remove a unit, either of two methods can be used. A flue cutter can be inserted in the same manner as the expander and the pipe is cut off even with the joint, or a flue pusher can be used, pushing the flue from the sheet. The ends, in the latter case, are swedged down to a gage below the size of the hole before being replaced.

As will be seen in the illustration, the vertical sections of each of the unit pipes at the front are offset to each side and so arranged that it is possible to remove the units from the two bottom rows without interfering with any of the others

box to facilitate cleaning and the removal or examination of any of the connections.

This superheater is being built by the Power Specialty Company, 111 Broadway, New York.

**NARROW ESCAPE OF A SPANISH TRAIN.**—On November 21 the Sud express, which runs from Paris to Madrid, narrowly escaped serious damage. As the train was passing through the Cazorza tunnel a part of the roof collapsed and two of the rear coaches were damaged by the falling debris. A brakeman was injured and four of the passengers complained of shock.

**ELIMINATION OF GRADE CROSSINGS IN GERMANY.**—The railway administrations of Germany are pursuing a consistent policy of grade crossing elimination, and work on the elevation of railroad tracks is everywhere to be observed, especially in and about the cities. The present laws relating to grade crossings are very strict. In Prussia, for example, all highway crossings on main lines must be protected by gates. The gates used are similar to those used in this country, except that a wire screen, or fence is usually suspended from the lower side of the arm to prevent people from passing underneath. Carefully formulated directions to the public are issued; and it is rare that they are disobeyed.

# Maintenance of Way Section.

THE contest on "The Proper Handling of Work Trains" is creating considerable interest in this important subject among both maintenance and operating men, and a number of excellent papers have already been received. The problem of when a work train is advisable, the proper organization of forces to man, but not over-man it, and the selection of the proper conductor or foreman to take charge, are but a few of the points on which the efficiency or inefficiency of this method of handling work depends. This subject is one in which the operating as well as the maintenance department is concerned, and some of the best papers received so far are from operating officers. Men of each department can make valuable suggestions, from their particular standpoint, all of which will assist in the more economical conduct of the work. We desire to secure as thorough and representative a discussion of this subject as possible, and to that end urge that those who have had experience along this line, send in contributions dwelling especially upon those features in which there is the greatest opportunity for error or improvement. We will pay \$25 and \$15 for the two best papers received, and our regular space rates for all other papers accepted and published. All contributions must be received by the engineering editor, *Railway Age Gazette*, 608 South Dearborn street, Chicago, by December 27, in order to be considered by the judges of this contest.

IN many ways the year now closing has been one of decided contrasts in both the construction and maintenance of way departments. After a winter unusually favorable for operation, and not particularly hard on track, the outlook early in the spring was for an even busier season than existed during the previous year. The past few months have shown how far these prospects failed of realization. The first serious obstacle to these plans was created by the widespread floods throughout the central and southern states in March and April, the immediate effect of which was to divert practically all the funds intended primarily for betterment work to repairs and reconstruction on the roads within the affected areas. On the contrary many of the roads without this region proceeded with their extensive programs and bought much material. However, as business conditions gradually changed and the money market tightened during the summer, much projected work was postponed and some work already begun was discontinued. The result has been that during the latter part of the summer and fall there has been a slackening in the amount of work under way, although projects which have been started have been generally carried to completion. This relieved the labor situation to some extent. During the early months labor was as scarce as during the preceding year, but with the slackening of work this condition very largely disappeared. Increasing attention has been paid during the past year to means for securing greater efficiency from the labor employed. The Baltimore & Ohio has continued the development of its piece-work system in track work, and has added a bonus schedule. A departure of a different nature but directed towards the same end, was adopted by the Long Island on May 1, whereby track work is distributed through the entire 12 months rather than the summer season. There was also a marked tendency on the part of many roads to start work earlier in the spring, due partially to the fear of a labor shortage and also to a realization of the economy of work performed in this season as compared with that done in the hotter months.

ALTHOUGH a very general feeling exists among executive as well as operating and maintenance officers that section foremen are steadily deteriorating in quality and efficiency and that the primary reason for this condition is the fact that the wages of these men has remained almost stationary, while that of other employees has steadily risen, no definite measures are being taken to correct this situation. It is true that on a number

of roads increases of \$5, and in some instances of \$10 per month have been made, but while in the right direction, this is still insufficient to attract the proper class of men. A few roads have increased the wages of section foremen to \$75 or \$90 per month, but on the other hand, many roads have made no increase and are still paying about \$50. With the passing of the older men the problem is rapidly becoming one of wages alone, and with this situation the conditions are ripe for organization. In fact, it is quite generally known that the organizations of track employees are gaining strength, especially in the eastern states. Much as the roads decry the rise and increasing strength of organized labor, they are neglecting the means to ward it off in this department, and by their attitude of indifference are in reality aiding this movement most effectively. With the class of men now employed as laborers it is evident that most of the foremen of the future must be recruited from outside the ranks. Numerous plans have been suggested and are being tried to train men for these positions. Mr. Wollner's suggestion that promising boys in the general offices be trained for this work is not as radical as might first appear. It possesses the important advantages that the fitness of the boy for track work may be judged before he is selected, and that the best men may be retained in the employ of the company when they would otherwise probably go into other industries. To make such a plan as this a success it is necessary that the men not only have proper training, but that they have a position ahead of them with a sufficient salary to cause them to strive for it. It is to be hoped that these conditions will be met and that this plan will be given a fair trial on some road.

CONCRETE has been used to a limited extent for water tanks and reservoirs for more than 10 years, but the total number of such structures is still small and a large proportion of those built have been for municipal water supply and are of such large capacity that they can scarcely be put in the class with tanks required by railways. In view of the limited data available on which to base designs for such tanks, the tendency on a number of roads to adopt this type of construction at least experimentally is to be commended as showing the willingness of railway engineers to utilize the latest developments in engineering practice to effect economies in their work. The principal advantages of concrete tanks are their permanency and their low cost of maintenance. In some locations the possibility of making a concrete tank more pleasing in appearance than one of wood or steel may also be worth considering. The exact figures on relative cost and life are not yet available, on account of the small number of tanks in service and the short time that has elapsed since their construction. The tanks described elsewhere in this issue cost \$6,400 and \$7,200, respectively, for the same capacity, the difference being caused by a difference of 20 ft. in height above the ground. Wooden tanks are being built for less than half the above costs and those that are well built of the best select cypress or equally durable timber are showing a life as high as 30 years. Yellow pine tanks of the type commonly built probably do not have an average life of over 20 years, but at least one road is seriously considering the possibility of increasing this life of pine to about 30 years by creosoting the lumber for the tub as well as the frame. More care is being given to the selection of material for wooden tanks and to their construction than ever before with the result that much better service can be expected from this type of construction. While wooden tanks are not likely to be entirely eliminated for some time, concrete and especially steel tanks can undoubtedly show economies for many locations and conditions. The choice of a tank like any other structure, should be placed on the basis of capitalized cost and all the available data bearing on the first cost, maintenance and life of all

of the types of tanks should be used in securing a fair comparison.

THE vice-president of one road and the general manager of a parallel line made a joint inspection trip over their two roads a few weeks ago. On the way out on one road they passed a work train with eight men loading rail with a locomotive crane. On the return trip on the other line that afternoon they passed a work train with 20 men loading rail by hand. The comparison was so evident that on the following day the division engineer on the latter road received authority to buy a locomotive crane at once. This latter road does not differ widely from many others, in that while the advantages of the adoption of labor saving appliances of this nature have been realized in the abstract, such devices have not been applied locally to the existing problems. The development of labor saving equipment during the past few years has been rapid and the various appliances have met with quite ready adoption on the more progressive roads. As illustrated by the use of a locomotive crane with a special grapple for loading ties, described elsewhere in this issue, the variety of uses in which such equipment may be employed is limited in large measure only by the ingenuity of the user. Rail loaders, ditchers and motor cars are other examples of power driven labor saving appliances in common use. The variety of uses to which the engine of the motor car has been applied make a large series in themselves. The primary advantage of all these labor saving devices is, of course, the reduction in the amount of labor required, thereby reducing the cost of the work. Another advantage is in the greater speed at which material may be handled, which is especially important when working on the main tracks or in congested places. One eastern road frequently uses two locomotive cranes when loading or unloading rail on the main track to expedite the work. With the increasing number of foreigners unfamiliar with work of this nature and with our methods, these appliances also become an important factor in decreasing the number of injuries.

IN spite of the fact that in most departments of a railway the amount of "red tape" increases with the growth of the system, more discretion regarding the specification of material is gradually being left to the men who use it. A few years ago the general practice was to leave the selection of materials entirely to the purchasing agent, the specifying of certain makes or types being discouraged, and this practice still exists on many roads. The feeling is gaining ground, however, that the man who uses the material should have a voice in its selection, and he is being encouraged more and more to investigate the various makes of materials and to give the purchasing department the benefit of his experience in the form of recommendations or specifications accompanying his requisitions. He is thus not only inclined to take more interest in the service of a particular tool or material, but his suggestions are of assistance to the purchasing department, which in many cases is at a loss to determine the relative merits of different makes of material. This plan has been carried still further on several roads by giving the men in charge of important work authority to purchase material locally when the interests of the company can be best served in this way. It frequently happens that unforeseen conditions arise requiring certain material to be secured on short notice. If the work is held up until it can be secured through the regular channels the delay may be serious and expensive. On one road now doing a large amount of new construction, the men in charge have been encouraged to purchase as much material as possible locally when it could be secured at moderate prices, and this policy has been reflected later in very favorable traffic returns due to the friendly feeling created among local business men. With proper supervision and the exercise of good judgment, the preparation of specifications, and in many instances the actual purchase of materials by the men who use them, will prove economical, because it will help to secure the materials best suited to the work, reduce the

amount of reserve stock and insure greater care in the use of the materials.

A WESTERN road recently installed a rock crushing plant at a considerable outlay to prepare ballast for its use. A man unfamiliar with the operation of a rock crusher was transferred from another department and placed in charge. The cost of the crushed stone was soon found materially to exceed previous contract prices, the plant was turned over to the contractor, and the project was considered a failure. Another road installed a plant of the same type at another quarry for the same purpose. A man experienced in operating such a plant was hired at a salary of approximately \$2,000, and was placed in charge. This plant was a success from the start, and the cost of ballast has been materially reduced from the contract price previously paid. In another instance a road built a large dredge of the most improved design to construct embankments. A machinist from the local division shops, entirely inexperienced in the operation of a dredge, was placed in charge, although skilled dredge operators could have been secured if the road had been willing to pay a considerably higher monthly rate. The result was that, although the output of this dredge compared favorably with that of older and smaller dredges in the vicinity, it was several months before it was brought up to what it really ought to have been. If these two instances were unusual they would not be of sufficient importance to mention here. Unfortunately they typify what frequently happens in railway operation. Railway men pride themselves upon being specialists in their particular branches, but they frequently lose sight of the fact that experienced men are equally valuable and necessary in other work. In dealing with any problem not within the scope of every-day railroad operation, the economy resulting from the employment of men skilled in a particular line is too frequently underestimated. A plant of sufficient importance to justify a moderate expenditure for equipment should warrant the employment of an experienced man to operate it. Contractors realize this more fully than railroads, and the roads might well profit by the example set by them in this regard.

ON first thought one might expect to find that there would be more data available regarding the cost of construction work in the possession of railroads than of contractors or private engineers. Railways do not have the business motive that a contractor has for keeping such information secret in order to gain some advantage over a competitor; they have complete organizations for compiling it; and they maintain well organized corps of skilled construction engineers and superintendents who are accustomed to handling large work creditably. Also, in these days when charges of incompetence and inefficiency against railways are so prevalent, one would think that the publication of unit costs of work well and economically done would reflect to their credit. However, engineers interested in the collection of data regarding construction costs are aware that there is a very general disinclination among railway men to giving out such information. The importance to a man in charge of work of knowing the unit costs of his work has been emphasized repeatedly in these columns. There is an equal advantage in an exchange of cost data between men engaged on the same kind of work. Men in all branches of railway work meet in associations to discuss the best methods of doing things. Could they not exchange figures regarding the costs of the things done by these various methods to equal advantage? Not only is there general reticence on the part of the railways regarding this information, but on many roads it is not kept in such a way as to enable the engineer in charge to have any definite idea of unit costs. No exchange of data of any value can be made until such records are compiled. A contractor who carried on a large piece of construction with as little information regarding his actual unit costs as that available on the average railway would soon be forced into bankruptcy.

# SCHUYLKILL RIVER BRIDGE IMPROVEMENTS.

Widening a Masonry Arch Structure on Pennsylvania Main Line in Philadelphia to Carry a Five-Track Passenger Line.

The main line passenger trains of the Pennsylvania between New York and Philadelphia and also the Atlantic City and other seashore passenger trains use a double track line between North Philadelphia and West Philadelphia. The requirements of this very dense passenger traffic have made necessary an increase in the capacity of this line and work is now under way which will provide four tracks over the entire section and five tracks in some places. The most important feature of this improve-

ment work is the widening of the Schuylkill river bridge and the structures over adjacent streets. The old bridge over the river, which was built about 1866, consisted of seven 60-ft. masonry arches and one 250-ft. deck truss span. This old structure was found to be in very good condition and, with some minor repairs, the masonry will be good for many more years of service. The old piers and arches



General View of Old Bridge.

ment work is the widening of the Schuylkill river bridge and the structures over adjacent streets.

## THE OLD AND NEW BRIDGES.

The old bridge over the river, which was built about 1866, consisted of seven 60-ft. masonry arches and one 250-ft. deck truss span. This old structure was found to be in very good condition and, with some minor repairs, the masonry will be good for many more years of service. The old piers and arches

placed, for a clear space of 13 ft. is left between the old truss and the two new channel spans. After the completion of the new portion of the bridge, traffic was turned over the two new tracks, and work is now under way on the necessary repairs to the old bridge.

In addition to the river bridge the work includes two 45-ft. arches adjoining the west end of the bridge spanning Lansdowne drive, and the boulevard entrance to Fairmount Park, a steel and

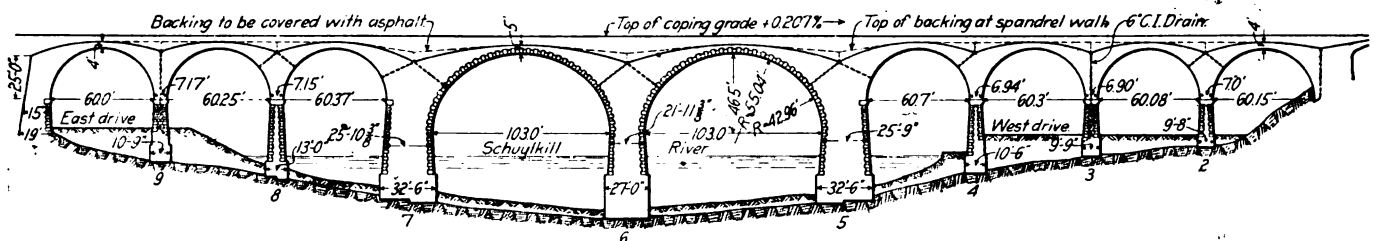

Longitudinal Section of Schuylkill River Bridge.

are being extended up-stream to carry the additional tracks, the new work being made to conform in appearance with the old bridge so that when finished it will form a single structure. In order to eliminate the steel span over the channel a center pier is provided which divides this span into two 103-ft. arches for the new structure. As the old truss still has about eight years of life it has not yet been decided whether it will be re-

placed, for a clear space of 13 ft. is left between the old truss and the two new channel spans. After the completion of the new portion of the bridge, traffic was turned over the two new tracks, and work is now under way on the necessary repairs to the old bridge.

## BUILDING THE NEW PIERS AND ARCHES.

The new river piers are all of concrete with ashlar stone facing. This facing is laid in the ordinary manner with two

courses of stretchers and one of headers. The new pier in the center of the river is 27 ft. wide and 90 ft. long over the footings, sufficient for a five-track bridge, the other piers having the same width as the old. The east abutment is 66 ft. 6 in. long and is built of concrete with ashlar facing. No west abutment is required as the end arch of the river bridge adjoins the first concrete arch of the Lansdowne drive bridge. The maximum depth to rock under the river is about 38 ft. below water level. This rock is overlaid by about 5 ft. of mud. The old river piers had not been carried down to rock, crib work being used either partially or entirely to support them. While this old

since their construction by the addition of a facing of ashlar masonry on the side opposite the arches as a precaution against damage from the thrust of these arches. This reinforcing masonry was carried down to rock alongside the crib work on which the original piers had been placed. In the present im-

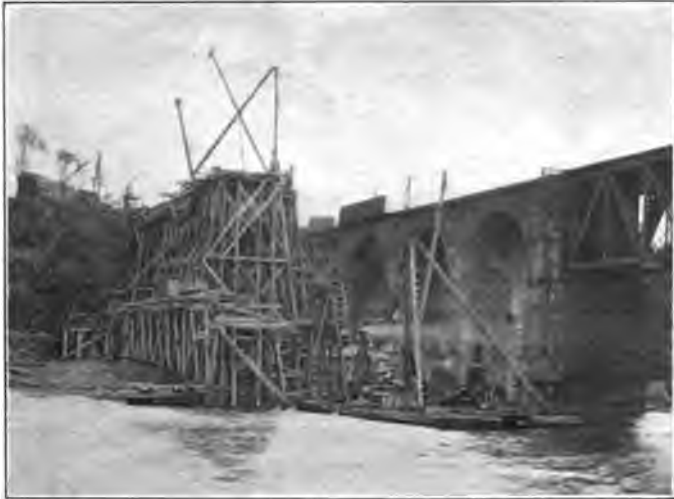

High Trestle for Bringing in Material.

crib work was apparently in excellent condition and no evidence of underscour could be found it was decided to place a concrete casing around the timber cribbing as an additional precaution. The two piers supporting the old truss span, which also served as abutments for the adjacent arches, had been strengthened



Two of the Old Arches at East End, Showing Material Track and Forms in Place for New Concrete Arches.

provement the old crib work has been encased in concrete, which is carried up a foot or two above the bottom of the old piers.

The work on the shallow piers on both shores was carried out in cofferdams of Lackawanna steel sheet piling which were pumped out to allow all concrete to be placed in the dry. Very light wooden cofferdams were used for the deep piers and no attempt was made to pump them out until the concrete footings had been completed up to an elevation 6 ft. below the surface of the water. The ashlar facing and the concrete backing above this level were placed in the dry. For placing the concrete



Low Level Trestle Across River from Which Concrete and Stone Were Placed.

under water both the closed chute method and bottom dump buckets were used at different times. This method was used very successfully a few years ago in building the extension of

sooner in this manner. The haunches of the arches were covered with concrete and concrete copings were securely anchored to the upper courses of the ashlar facing by dowels. A



Double-Track Addition to Schuylkill River Bridge Before Placing Railing.

the Schuylkill river bridge on the approach to the Broad street station.

The old arch rings were of brick having eight courses. The facing was of ashlar masonry. In some places it will be necessary to repair this brick ring and as an added precaution a

new coping will also be placed on the south side of the old arches to make the bridge uniform in appearance. An ornamental concrete railing will be carried on this coping, as described later in connection with the Lansdowne drive bridge.



Arch Bridge Over Lansdowne Drive.

thin reinforced concrete mattress will be placed over the arches. The new arch rings are of concrete, non-reinforced, with ashlar facing. The rings are 4 ft. thick at the crown and the facing is made of 3 and 4-ft. ring stones of a hard grade of sandstone from the Clearfield County, Pa., quarries. The two 103-ft. arches were turned with ashlar masonry instead of concrete in

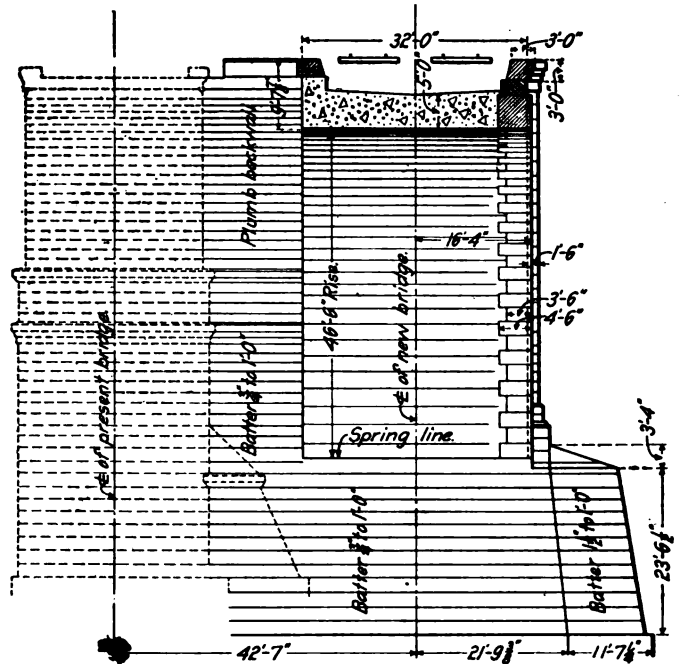

Transverse Cross Section Through 60-Foot Arch.

CONTRACTOR'S PLANT.

The construction plant for placing the river spans was brought in from the east side where a siding from the main line was

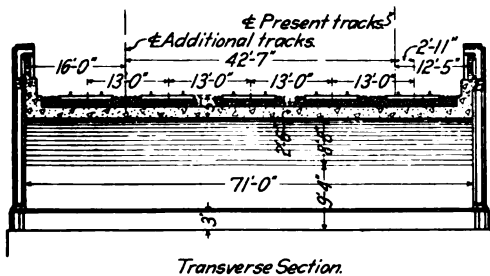

Transverse Section.

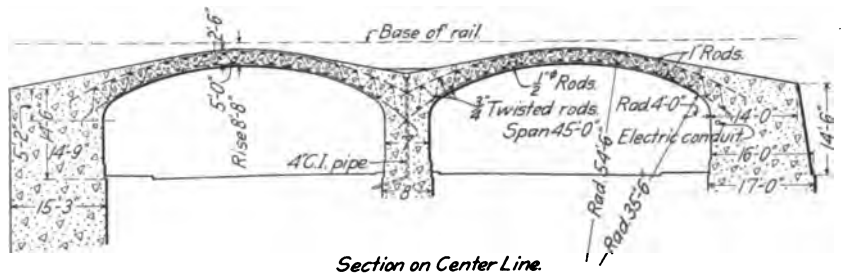

Section on Center Line.

Sections of Concrete Arches Over Lansdowne Drive.

order to save the time in construction which would be necessary for the setting of a long span concrete arch. It was estimated that the work could be completed at least one month

provided. A temporary trestle on about the same grade as the old bridge was built from the high bank on the east shore out to the water's edge. A second trestle at an elevation a little

above the springing line of the arches was built with its end adjacent to the high level trestle so that material received on the siding could be brought out on the high trestle, lowered to the low trestle and carried out to any portion of the work. The concrete mixing plant was located at an elevation between that of the high and low trestles so that cement and sandstone could be handled to the mixer and the concrete from the mixer by gravity. A cement house and facilities for storing sand and gravel were provided along the siding. The concrete plant included three mixers, two of which were of 1-yd. capacity. The best day's run with these mixers was about 450 yds. The concrete used for backing was a 1:3:5 mix and that in the arch rings 1:2:4. The concrete was handled from the mixing plant to the piers in 1-yd. buckets carried on narrow gage cars which were pulled along the trestle by a dinky engine. Five steel-boom derricks located at uniform intervals along this trestle handled these buckets from the cars to the piers. These derricks were supported on clusters of long piles driven into the mud on the

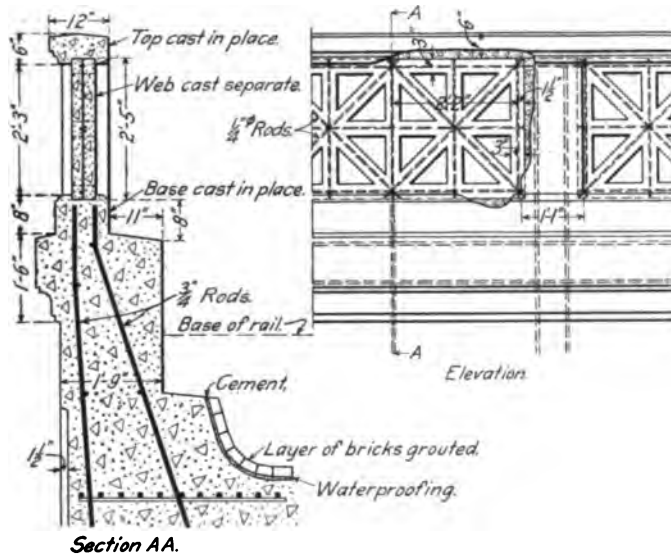

Section AA.  
Details of Ornamental Concrete Railing on Lansdowne Drive Bridge.

river bottom. Steel centers were used for supporting the arch rings, these centers being carried on framed bents resting on offsets provided on the sides of the piers.

#### LANSDOWNE DRIVE AND GIRARD AVENUE BRIDGES.

The new structure over Lansdowne drive consists of two five-centered 45-ft. arches which replace five 21-ft. segmental arches. Although the very flat arch which was adopted for this structure is perhaps not as pleasing as the segmental type for a structure in which esthetic design is important, this type was made necessary by a lack of head room. The railway grade over the arch was, of course, fixed and that fact combined with the clearance necessary for the automobile traffic under the arch very closely limited the choice of a curve for the intrados. These arch rings are very heavily reinforced and are covered by a fill of one and two-man stones up to an elevation 2 ft. below the base of rail. On this fill the regular stone ballast is laid. The faces of the arches, the end of the center pier and the two pilasters are paneled, and all of the concrete in the face of the structure is bush hammered with the exception of 1-in. strips along the corners, which serve to outline the structure very effectively. Panels of 6 in. by 6 in. green Grueby tile are set in the concrete at the tops of the pilasters. The surface of the west abutment is broken by horizontal scoring which harmonizes well with the details of the rest of the structure. The coping along the abutment and over the arches is surmounted by an ornamental concrete railing, shown in the accompanying photograph, which is cast in short sections in a yard especially fitted

for this class of work, the units being held by the upper and lower rails, which are moulded in place.

The Girard avenue structure, which crosses an important street at a skew of 32 deg. 43 min., is of steel construction, having longitudinal girders supported on center and curb columns. A solid concrete floor is laid on transverse I-beams, and the columns and girders are encased in concrete. The ornamentation of the bridge conforms to that used on the Lansdowne drive arches, including the scoring on the abutments, panels on the faces of the girders, green tile on the abutment pilasters and the ornamental concrete railing.

The waterproofing on the Girard avenue and Lansdowne drive bridges is five ply Hydrex covered by bricks which are grouted in cement. Fibre conduits are carried across these structures to encase telephone, telegraph and signal wires. Provision has also been made in separate conduits for power wires which would be required in the event of possible electrification of this line. These conduits are supported across the space over the haunches of the arches on old rails laid on the crown of the arch.

The crossing of the Philadelphia & Reading tracks east of



Steel Encased Bridge Over Girard Ave.

the river is made on a concrete arch which is of standard construction and has no unusual features.

The addition to this bridge was begun in July, 1912, and work has been prosecuted continuously since that time. Traffic was turned over the two new tracks on November 2. This work was handled under the direction of A. C. Shand, chief engineer; E. B. Temple, assistant chief engineer, and W. L. Zeigler, engineer of construction. Eyre Shoemaker, of Philadelphia, is the contractor for all work adjacent to the river crossing.

## RESPONSIBILITY FOR MINOR DERAILMENTS

By E. R. MEREDITH,

Supervisor, Philadelphia & Reading, Coatesville, Pa.

One of the most vexing phases of railway operation is caused by the small derailments in yards and on the line where one or two cars or even pairs of wheels get off the track. The actual money value of the repairs to track and equipment is usually small. These derailments are accepted as necessary evils, and no account is taken of their wider-reaching effects in delays to train movement and to the complete upsetting of a well-planned day's work by yardmasters and dispatchers. The investigations are usually more or less perfunctory and are often merely attempts of the various departments to saddle the blame on each other and to clear their own skirts. It is even considered a clever bit of work when the roadway, the transportation or the inspection department can unload the blame from its own shoulders to its neighbor's.

The writer believes that this is wrong. It has been his experience that such a course leads to carelessness on the part of all concerned, to personal friction between the heads of departments, and especially between their subordinates, and to a gen-

eral attitude which prevents harmony of effort among the various employees, a harmony whose value cannot be measured in exact dollars and cents, but which, nevertheless, is one of the most necessary and valuable assets in economic operation. With this end in view, absolute fairness and frankness in the investigation of these small accidents, and willingness to accept responsibility for them are required. It goes against the grain, of course, to admit that one's own department is partly at fault in such matters, but this personal humiliation should not outweigh the certain benefits of an honest understanding of all the causes of the trouble.

Nearly all these accidents are due to a combination of causes but it is the custom to select the most glaring of these and to disregard the others. Each department head, of course, sees most clearly the errors of omission and commission of his neighbors, and, voluntarily or involuntarily, shuts his eyes to the shortcomings of his own men. This tempts all concerned to conceal their own liability and to feel that when they have done so they have done a creditable thing, a feeling which, unfortunately, is sometimes connived at and even encouraged by the very men to whom the management looks for an unbiased administration of the divisional departments.

The department of railroad work with which the writer has always been associated is the roadway. Numerous investigations of derailments on the line and in yards have convinced him that in nearly every case the track is in part responsible. This statement will no doubt be challenged by the great majority of maintenance of way officers, but he repeats that a fair and honest investigation will convince an unbiased authority that for these minor derailments the roadway department must almost always take a share of the blame. It is not meant that they are entirely or even primarily responsible, but that they are in a measure at fault. It is not sufficient to say that because the load shifted, the trucks were defective, the flanges sharp or the car did not slew the roadway is absolved, but it must first be proven that the same accident would have occurred under perfect conditions of line, surface, elevation, etc. To say that a piece of track is put up well enough for cars in average condition to operate safely does not free us from responsibility when a car below the average is derailed, provided that if the track had been a little better, the accident would not have occurred. A switch may be sufficiently well adjusted to permit a thousand ordinary cars to pass over it with perfect safety, but if one of the thousand with a flange sharper than it should be picks the point, open slightly, the sharpened flange should not be credited with all the blame. Some of it belongs to the roadway department. Instances could be multiplied indefinitely of these minor accidents resulting not from one specific cause, but from a number of causes, each insufficient in itself to make the trouble.

If this is true of the roadway department it is equally true of the others. Derailments primarily due to track defects are assisted by defective equipment, improper loading and careless handling. Closer inspection of cars and lading would go far towards reducing the number of these accidents. Rigid discipline and close supervision of crews to avoid careless handling and fast running would do as much more.

In these days of lowering income and increasing expenses it is not merely true that the penny saved is the penny earned. It may even be the only penny on the right side of the big ledger. In the prevention of these minor accidents there is a large field for saving. Department heads can do no work better worth while than to investigate their causes frankly and fairly. With the results thus obtained they will be in a position to get after the causes and so to improve their departments that a large number of these vexatious and indirectly costly accidents may be averted. There is no use trying to load it all on the other fellow, if part of the blame belongs to you. By so doing you are inviting a second accident just like the first, you are encouraging your men in careless habits, irritating your co-workers, and, worst of all, you are wasting your employer's money in preventable accidents.

The proper thing is for all concerned to get together, ascertain all the real causes, not merely the main one, and then each man should get after his subordinates with a sharp stick to remedy the weak spots in their work uncovered by the investigation.

When one's own department has been brought up to such a state of perfection that no accidents can be attributed to it even in part, he is in a position to hold up his neighbor to ridicule, but not till then. The old saying concerning beams, motes, brothers and eyes is as true of twentieth-century railroad operation as it was of the rural life in Palestine two thousand years ago.

## CONVENTION OF THE WOOD PRESERVERS' ASSOCIATION.

The tenth annual convention of the American Wood Preservers' Association will be held at the St. Charles hotel, New Orleans, La., January 20-21-22, 1914. Papers will be presented on "Treatment of Piling and Timber According to Conditions of Use and Exposure," by E. L. Powell, vice-president, American Creosote Works; "The Effect of Varying the Preliminary Air Pressure in Treating Ties Upon the Absorption and Penetration of Creosote," by Clyde H. Teesdale, Forest Products Laboratory; "Mechanical Handling of Railroad Cross Ties and Timbers at Timber Preservation Plants," by Lambert T. Ericson, assistant superintendent, Port Reading Creosoting Plant; "Methods of Keeping Tie Records," by E. T. Howson, engineering editor, *Railway Age Gazette*; "Air Pumps Versus Pressure Pumps for Injecting Preservatives Into Wood," by F. J. Angier, superintendent timber preservation, Baltimore & Ohio; "Future Tie Material in the United States," by H. H. Gibson, editor, *Hardwood Record*; "The Protection of Ties from Mechanical Destruction," by Howard F. Weiss, director, Forest Products Laboratory; "Preliminary Work in Fireproofing Wood," by Robert E. Prince, Forest Products Laboratory; "The Yale Forest School," by Samuel J. Record, assistant professor of forest products, Yale University; "Some Methods of Separating Water from Creosote Oil," by Thomas White, assistant manager of American Creosote Works; "A Comparison of Wood Paving in European Countries and the United States," by S. R. Church, manager, research department, Barrett Manufacturing Company; "New Type of Paving Block Plant," by J. B. Card, manager, Chicago Creosoting Company; "The Construction of Creosoted Wood Block Pavements," by R. S. Manley, president, Creosoted Wood Block the slopes varying from two in. per ft. to four in. per ft. Paving Company; "Results Obtained by Piling Creosoted Wood Blocks Closely in Cages and the Saving Effected Thereby," by R. H. White, president, Southern Wood Preserving Company.

In addition to these individual papers, reports will be presented from standing committees on "Preservatives," "Preservation of and Specifications for Timber, Ties and Piling," "Wood Block Paving," "Plant Operation" and "Miscellaneous Subjects."

On Wednesday a trip will be made to the plant of the Great Southern Lumber Company at Bogalusa, La., said to be the largest saw mill in the world. An hour's stop will also be made at the plant of the Southern Creosoting Company at Slidell, La.

**SLOPE OF CONCRETE CHUTES.**—Considerable experience was gained in chuting concrete to place in building the numerous concrete structures in connection with the elimination of grade crossings on the New York, Chicago & St. Louis in Cleveland. According to the statement of A. J. Himes, engineer of grade elimination, in Bulletin No. 160 of the American Railway Engineering Association, wooden chutes were made two ft. wide and 8 to 10 in. deep. With planed boards, the preferable slope is four in. per ft. Slopes of two in. per ft. require a man to keep the chutes clear and of six in. per ft. cause the ingredients to separate and require the use of baffles to retard the motion. Iron chutes were made 20 in. wide and 8 in. deep, depending upon the amount of water in the concrete.



## NEW COALING STATIONS ON THE OREGON SHORT LINE.

A new coaling station which includes a combination of power operated coal breaker with a balanced bucket elevating system, scale pockets and scales and complete sand handling equipment has just been completed at Minidoka, Idaho, on the main line of the Oregon Short Line. The details of this design were worked out by the engineering department of the Oregon Short Line under the direction of Carl Stradley, chief engineer, in connection with the T. W. Snow Construction Company, Chicago. This plant is of the balanced bucket type and is of steel construction throughout with the exception of the power house and sand drying house, which are of brick.

Briefly, this coaling station includes a power operated coal breaker or crusher for sizing the coal instead of the usual breaker bars, with a hopper below the level of the track of sufficient capacity to hold a carload of coal. By this means, the customary trouble with the choking of the coal in leaving the cars is eliminated as the coal has a clear drop into the



New Coaling Station and Sand Handling Plant at Minidoka, Idaho.

hopper. Two 1½-ton buckets fed by automatic cylindrical loaders, elevate the coal into the overhead bin from which it is dropped by gravity into two 8-ton scale pockets each equipped with a hopper scale with registering beam, which punches the weight of coal on a printed card. From the two 8-ton pockets the coal is delivered to three tracks as shown, by means of side swaying spouts covered at the lower end to prevent spilling coal over the side of a locomotive tender.

In addition to the coaling station, a dry sand house and a wet sand bin are provided. The former is equipped with a "Viloco" automatic sand dryer and an improved sand screen. The dry sand drops by gravity into a pneumatic sand tank and is then elevated by means of compressed air into the small cylindrical tank shown over the tracks in the photograph.

This plant has a capacity of 60 tons of coal per hour and

over 10 cu. yds. of dry sand per day of 10 hours. The entire plant, including the coal breaker, is operated by a 40 h. p. Otto gasoline engine adapted to use distillate as fuel. The engine is started on compressed air furnished by the compressor of the sand handling equipment.

When drop bottom self-clearing coal cars are used to minimize the amount of shoveling required, this plant will handle between 300 and 400 tons of coal per day with a force consisting of one engineer and two helpers and this capacity can be doubled if necessary. The storage bin holds 200 tons, the plant being designed for economical handling of coal rather than for large storage capacity.

As a result of the successful operation of this plant at Minidoka, a similar one is now being built on the same road at Kemmerer, Wyo. Another coaling station of the same general design but for two track service, has been erected at Bancroft, Idaho, on the Oregon Short Line. This station has a capacity of 40 tons per hour with a 150-ton storage bin and is equipped with breaker bars instead of the power operated crusher for sizing the coal. Two other Snow steel coaling stations have also been built recently on the Oregon Short Line at Twin Falls and Jerome, Idaho.

## BRIDGE INSPECTION ON THE B. R. & P.

The Buffalo, Rochester & Pittsburgh engineering department, of which E. F. Robinson is chief engineer, has recently prepared a "Blue Book" on inspection, which covers in a brief but comprehensive manner every inspection required in the maintenance of tracks, structures, water stations, signals and scales. The instructions referring to bridge inspection are of particular interest in connection with the discussion of this subject which was published in the *Railway Age Gazette* of November 21.

On the B. R. & P. trackwalkers must inspect all bridges and culverts daily, reporting their condition to the section foremen. The section foremen must make a general inspection of everything on their sections once each week, including bridges and culverts, particular attention being given to abutments, piers, pedestals, bearings, piles, bents, stringers and caps. The foremen report to the roadmasters on matters requiring attention which they are unable to correct, a special weekly report being made to cover all pipes, culverts and bridges. If everything is in good condition one report can be made giving a list of the structure numbers, but if any structure requires work a separate report must be made for that structure.

Division inspectors make a detailed and careful inspection of bridges and culverts each month, reporting the result of such inspections to the supervisor of bridges and buildings. Separate reports are made for each structure and copies are sent to the division engineers. This inspection is made "out of face" on foot or speeder. As a bi-monthly inspection of all structures not covered by the monthly inspection is required, a man from the regular force accompanies the division inspector on this bi-monthly trip in order to cover bridges and buildings on the same trip over the line. Roadmasters and supervisors of bridges and buildings make special inspections of their entire divisions every three months. The two men travel together on foot, hand car, or motor car, and the reports are made to the division engineers, giving dates, conditions and recommendations in detail. The division engineers, signal engineer, master mason and supervisor of water service, accompanied by the supervisor of bridges and buildings, roadmasters and supervisors of signals, inspect the entire property during the months of April and May and again during the months of October and November. This inspection is made "out of face" on hand car or motor car, and a full report is made to the chief engineer. The general inspector inspects and reports to the chief engineer on the condition of the entire property once each year. This report shows the condition of each mile separately.

# MAINTENANCE OF WAY MASTER PAINTERS' ASSOCIATION.

Second Half of Report of Recent Convention at Louisville  
with Abstracts of Several Papers Presented for Discussion.

In the closing business session of the tenth annual convention of the Maintenance of Way Master Painters' Association, held at Louisville on Thursday, November 20, the following officers were elected for the coming year: President, C. H. Plummer, C. R. I. & P., Topeka, Kan.; first vice-president, F. C. Rieboldt, C. M. & St. P., Milwaukee, Wis.; second vice-president, E. R. Cope, Pennsylvania Lines West, Pittsburgh, Pa.; secretary-treasurer, T. I. Goodwin, C. R. I. & P., Eldon, Mo. The next convention will be held at Detroit, Mich., November 17-18-19, 1914.

In addition to the papers published in the *Railway Age Gazette* of November 21, page 982, the following were presented:

## TESTS OF BRIDGE PAINT.

A paper by J. S. Rice (L. S. & M. S.), discussed the results of a test of a number of bridge paints first exposed in March, 1907. A partial report of this test was made at the convention three years ago, but as it has now been more than six years since the beginning of the test, some definite information can be obtained as to the relative value of the paints.

All of the pieces of metal are showing some rust around the holes which were used in nailing the pieces to the wooden supports. The first three samples are composed of red lead straight, using different proportions of lead to the gallon of oil. The next three have the same proportions of lead with lamp black added. The next sample has red lead straight, for first coat, red lead and lamp black for second coat, and straight lamp black for the third coat. The eighth has only ten pounds of red lead and one pound of lamp black for the first and second coats, and plain lamp black for the finishing coat. This is the old Lake Shore formula for painting bridges. No. 9 has 33 lbs. of red lead to the gallon of oil, and instead of using all linseed, one-quarter of the vehicle is benzine. All of these samples are in good condition. They were made of pure materials, and are showing the superiority of pure red lead as a pigment for paint to be used on structural steel.

No. 10 has three coats of Eddy's lamp black, and No. 11 three coats of Germantown make mixed with oil by hand. These are showing signs of rust; the latter, however, more than the former, due apparently to a difference in quality, one costing 20 cts., and the other 13 cts. per lb.

In No. 12, the order of painting was reversed, lamp black being used for the first coat, red lead and lamp black for the second coat, and straight red lead for finishing. This sample is a complete failure and shows the fallacy of using a thin, soft paint at the bottom and a heavy, hard paint at the top as some people have recommended. No. 7, with the painting done in the reverse order is wearing well. A complete knowledge of the composition of a paint, will often prevent such mistakes.

Nos. 13 and 14 are graphites which are said to contain under 50 per cent. of pure carbon, and they are showing signs of rust—one more than the other. Nos. 15 and 16 are carbon paints and are commencing to rust. No. 17 is supposed to contain Portland cement and white lead, in the pigment. This sample is badly rusted. No. 18 is a combination paint of red lead and carbon which is sold by the manufacturer in ready mixed form. It is standing in good shape.

No. 19 is similar in composition, but has white inert material added. It is not doing so well. Nos. 20 and 22 are carbon paints possessing different amounts of carbon. Both are beginning to show rust. No. 21, was omitted from the numbering.

Nos. 23, 27, 28, 30, 31, 32 and 38 are samples on which different kinds of pigment were used for each coat. The first coat was a heavy paint, the finishing coat being lighter and softer with the second coat of medium weight. All these paints are doing well at present. No. 35, which is of similar construction is the only one which shows any rust spots. No. 24

is a dark olive green paint supposed to have a white lead base. It is wearing well. No. 25 has red lead and lamp black and white inert pigment and at the present time is all right.

No. 26, which consists of red lead and graphite in equal quantities, is beginning to rust. No. 29, a mixture of red lead and iron oxide is doing well. No. 33 is a ready mixed red lead paint, about 65 per cent. pure. It is rusting badly. No. 34 is a high-grade asphaltum paint—the metal is rusting very badly. No. 37 is a high grade iron oxide paint. It has done well for a paint of this kind, but is beginning to show signs of rusting. No. 39 is another iron oxide paint having a much larger percentage of iron. This is still intact. No. 40 is a lead and zinc paint of grey color, and is supposed to have a small proportion of white inert material in combination. It is rusting badly. No. 41 is a ready mixed red lead with much less proportion of red lead than No. 33. It is in worse shape than 33.

No. 42 is a graphite paint having over 75 per cent. of carbon. It does not show rust. No. 43 is a blue lead paint, with white inert added. It is rusting and not doing as well as if it had been made of the pure material. No. 44 is a carbon paint of good quality, and at present is doing well. No. 45 is made from one of the Utah asphaltums or hydrocarbons and like other paints of its kind is now scaling badly. No. 46 was said to have graphite and lamp black combined. It is rusting. No. 47 is a manufactured graphite of high purity. It commenced to show rust spots in 1910.

No. 48 is another ready mixed red lead paint and was said to have some iron oxide combined with the lead. It is rusting. There is no No. 49. No. 50 was made of a coal tar product which has been hard pushed by its manufacturer and has no linseed oil in it. It began to fail early in the test and is now completely rusted.

At the present time it is safe to draw the following conclusions: First, that paints made of linseed oil, are the only ones which can be depended upon for good wear on bridges, and structural steel; second, that it is better practice to use paints of different composition and colors for each coat, whether on new work or the repainting of old structures; third, that red lead paints made pure will wear longer than when adulterated with white inert pigments; fourth, that the heaviest paint should always be at the bottom as a foundation coat; fifth, that paints made of coal tar and asphaltum should not be applied next to the iron if best results in wear are desired.

## TEST OF SIX BRIDGE PAINTS.

A. B. Phelps (L. S. & M. S.) reported that he applied six brands of black paint on a bridge at Vermillion, Ohio, on the main line of the Lake Shore & Michigan Southern in July, 1911. The bridge carries three traffic tracks and has three spans, one riveted plate girder being used under each rail, making six girders for each span and eighteen in all. Each of these girders is 10 ft. deep and 90 ft. long. They received a shop coat before leaving the bridge plant which was supposed to consist of red lead and lamp black in proportion of 1 to 10. They were stored from four to six months before erection. After being placed in position there was applied to the six girders in the east span, two coats of the following paints, one kind on each girder: Mancolite, Steel Preservative, Lino Metal Paint, Nev-a-rust, U. S. N. Armor Black, and Nobrac.

The middle six girders were treated in the same manner except the order of the paints was shifted so as to make the test as fair as possible. The six girders in the west span were given one field coat of a ready mixed red lead, called "Ferric" red lead, over which was applied one coat of each of the above mentioned six black paints, again shifting the order. On October 31, 1913, after 27 months of exposure, an inspection was

made which showed that all of the girders in the west span which had received one field coat of ready mixed red lead before the application of the black, were in better condition than any of the twelve which had been given two coats of the black paints and no field coat of red lead.

All of the paints are still intact with the exception that in a number of cases the top flanges show the effects of corrosion from brine drippings. In one girder the rivet heads in the lower flange are rusting slightly and in two cases the color on the outside girders is fading somewhat.

#### WORKMEN'S COMPENSATION LEGISLATION.

The following paper was presented by Edward H. Brown, editor of the *Painters' Magazine*.

Workmen's compensation laws are already in force in 17 states and federal legislation of this character is being actively urged and will probably be passed at the next session of congress. Similar laws have been enacted or are under consideration in all the provinces of the Dominion of Canada.

Briefly, the effect of these laws is to deprive the employer in suits brought by workers to recover damages for injuries sustained in connection with their occupation of the three common law defenses which have been used; first, the assumption of risk in accepting employment; second, the negligence or fault of a fellow servant, and third, contributory negligence on the part of the injured employee.

Most of the American workmen's compensation laws have been modeled after those in force in England, although so far none of them have included occupational diseases. In Ohio, the law provides for an insurance fund managed by the state, this insurance being compulsory with all employers, except corporations of certain financial responsibility, such as railway companies, which may maintain approved benefit funds or mutual insurance associations with the provision that they must contribute to the reserve of the state fund. In the state of Washington, workmen's compensation insurance is managed by the state and all employers are compelled to insure through this fund. In some states such laws apply only to certain occupations classed as dangerous or hazardous. In the State of New Jersey, however, the law applies to all classes of labor and to all employers, except in the case of temporary employment.

Thoughtful people almost universally agree that workmen's compensation is more equitable than the old common law theory which made the employee bear the entire burden of injuries or disease resulting from his occupation. The advocates of such legislation urge that it need not bear heavily upon employers because they may protect themselves by insurance, raising the prices of their products to meet the cost of such insurance. This may be true of manufacturers but it does not apply to railways. The Interstate Commerce Commission and public service commissions in the various states very effectively prevent the roads from increasing their revenue and the stockholders naturally look on workmen's compensation laws as one more straw added to the burden that is gradually breaking the camel's back. If no relief is granted, the return on railway investments will undoubtedly be reduced to a minus quantity.

Various workmen's compensation laws that have been enacted however, are only the opening wedge. If it is just that the industry should bear the burden of its accidents, why should this principle not apply equally to occupational diseases.

In many occupations, including painting, diseases are caused by poisonous materials used, by dust that is inhaled, or by working in close, ill-ventilated quarters. In England, the industries must now bear the burden of such diseases and trade unions of this country are beginning to advocate similar laws here.

As master painters you are not financially responsible for this burden but in safeguarding the interests of the companies which employ you it is your duty to look out for the safety of your men, so far as possible, and to recommend to your superior officers the adoption of any devices that may prevent or reduce accidents and disease to a minimum.

There are many dangers to which roadway, bridge and building painters are exposed, and which master painters must caution them against. When painting switch targets and signals, special care must be taken to avoid being run down by trains when moving from place to place on a hand car or speeder. Men painting bridges must always use special caution and it would seem prudent to require a new man to pass a physical examination to see that he is free from stomach, kidney and nervous trouble of all kinds before putting him on bridge painting, especially over running water. Under workmen's compensation laws the railway may be compelled to pay a man a pension for months or even years for an accident caused by his own weakness if this weakness is not detected before he is employed. Men should be very carefully instructed in the proper handling of gasoline torches for burning off old paint, and unusual measures should be taken to avoid the dangers due to carrying and working with highly inflammable and explosive materials. The men should not only be forbidden to smoke in, or carry a light into a car containing turpentine, benzine, naphtha, or varnish, but it should be impressed upon them that disobedience to this rule will be sufficient cause for dismissal. The only kind of portable light that can be employed in a car containing volatile inflammable materials is an electric flash-light.

In probably no other line of industry are more dangerously poisonous materials used than in the painting trade. Among the pigments are white and red lead and chrome yellow. Among the liquids are turpentine, benzine, benzole, carbolic acid, carbon di-sulphide, etc. Another danger to which the painter is exposed is the dry sand papering of lead paint, or the chipping off of old red lead. The practice of eating with unwashed hands or without changing the clothes while at work may result in introducing lead into the system, and causing lead poisoning. Dizziness, which may cause a man to fall and receive serious injury, is frequently caused by inhaling the fumes of turpentine or benzine.

The department of labor has been studying the question of occupational diseases and those incidental to the painters' trade have been made the subject of Bulletin No. 120, recently issued by the Bureau of Labor Statistics. In the summary, Dr. Hamilton says:

"This study of the painters' trade in the United States shows that there are many elements of danger, most of them avoidable, and it shows that if protective legislation is to be passed it should be directed toward the prevention of poisonous fumes and dust, and the provision of facilities for bodily cleanliness.

"Such legislation should forbid, first, the use in unventilated rooms of paints or paint removers containing volatile poisons; second, forbid dry sandpapering or dry chipping off of lead paint; third, insist that the employer provide a proper place for his workmen to hang their street clothes and keep and eat their lunch, and a washroom with a sufficient number of basins, warm water, soap, towels and brushes; fourth, require the labeling of all paint offered for sale in such a way that the painter can be apprised of the danger involved in its use; and fifth, in the case of work done in factories, cards of instruction for the workmen should be posted, and if necessary these should be written in one or more foreign languages."

It seems that the facts brought out in this report could well be brought to the attention of the safety departments of the railways. The bulletin shows that by using proper precautions, the dangers from poisoning from materials used in painting can be minimized almost to the point of elimination, but that without such precautions a much larger proportion of painters show symptoms of occupational disease than is usually recognized.

#### DISCUSSION.

The discussion following Mr. Brown's paper covered various subjects referring to the safety of men employed in painting large structures and the precautions that should be taken by foremen, particularly in view of the liabilities imposed by the new workmen's compensation laws. It was repeatedly emphasized that foremen must personally inspect ropes, planks and other

rigging used by the men on high structures where the danger is great. One member suggested that he had found it well to use rope as large as 1 or 1¼ in. to support the staging on bridges over 100 ft. high as with the large rope there is less danger of its being worn through when it passes over sharp edges or of its being cut by coal or other material falling from the deck of the bridge. A number of other members, however, differed from this opinion on account of the fact that large rope is unwieldy to handle, thereby increasing the danger to the men. Several expressed the preference for ½-in. rope and these members agreed that ¾-in. rope was probably the largest that should be used. The practice of cutting a rope immediately when it is noticed that one strand is broken, was generally approved in order to prevent any chance of its being used in an unsafe condition.

#### SAFETY IN THE STORAGE OF OILS AND PAINTS.

The following abstract is from a paper read at a meeting of the Safety Committee of the Atchison, Topeka & Santa Fe, by J. W. Gibbons, foreman locomotive painter, and presented to the Master Painters' Association, by Mr. Brown:

I have divided the subject into three parts, mineral oils, saponifiable oils and paints and varnishes.

Mineral oils are all a product of crude oil, including gasoline oil, benzine, coal oils and high grade kerosene oils, among which are headlight oil, mineral seal, paraffine oil, lubricating oils, etc. There is little if any danger of spontaneous combustion from mineral oils, unless subjected to a very high friction. But a large percentage of these oils are explosive, and in handling them care should be taken never to expose them to an open flame or spark of fire. And, as the volatile oils constantly throw off gas, all vessels used in transporting them should be absolutely air tight, as a small vessel containing this class of oil in a warm room would in a few minutes throw off enough gas to cause an explosion upon the striking of a match, or entering the room with a lighted pipe or cigar. This is why the "no smoking" rule should be strictly enforced in all buildings or cars used in the storing or transportation of oils.

Special care should be taken when putting oil into containers to allow for the expansion of the oil, for in hot weather, or if in close proximity to fire, or in a hot room, the expanding gas arising from the oil might cause an explosion.

In using volatile oil for cleaning or similar purposes it should be drawn off into a bucket equipped with a lid, fastened on by a hinge, and when not in use the lid should be closed tight.

When a vessel containing gasoline or other oils becomes ignited, do not try to carry the vessel out of the building. More people are injured and small fires made large conflagrations by people spilling the oil over the building than by the explosion of the oils. Remember, all danger of explosion is over after the first flash. This flash is caused by the accumulated gas becoming ignited and after this accumulated gas is consumed the fire will burn evenly, and if the flame does not endanger the surrounding property no harm would result other than the loss of the oil, and possibly the container if you would let the fire burn itself out.

All that is necessary to put out a fire of this kind is to cover the opening in the vessel with a piece of sheet iron or wood, or smother it by holding a heavy cloth over it closely. The fire extinguishers, which are found in every part of the shop and office buildings, are also very effective in extinguishing flames of this nature.

Under the classification of saponifiable oils, we have the various kinds of vegetable oils and those oils obtained from animal fats. These oils are not explosive unless heated to a very high temperature. But they are more or less liable to cause spontaneous combustion. This is particularly true of linseed oil, and in cleaning or polishing any article with these oils great care should be taken to destroy the waste or rags which are used in wiping.

To demonstrate the danger of fire of this nature take a piece of waste, saturate it with linseed oil, rub it between your hands and then throw the waste where it can do no harm and watch

it. In a few moments you will see smoke arise, and, if you wait long enough, the waste will blaze up. And you can imagine the result if that waste or rag was in a bin of waste or other inflammable material.

All paints contain either mineral or saponifiable oils, and some paints contain some kind of vegetable oil. So paints and varnishes are either explosive or they add to the danger of fire by spontaneous combustion if not handled properly.

A barrel of oil or paint found leaking in the store room or in a car, whether it is a commercial or company shipment, should be reported immediately. The barrel may contain volatile oil, and if the journal of the car runs hot and the waste in the box catches fire instead of a hot box we have a box car or a train on fire.

If the barrel contains linseed oil or varnish it may bring out the same result by friction or spontaneous combustion. It is not only in the leakage of barrels that this danger may arise, but frequently we set aside barrels that are supposed to be empty, and yet contain enough oil to start a fire if not properly handled. So before shipping empty barrels or drums in which paints or oils have been stored or using them for other purposes care should be taken to see that all residue is removed.

#### A DEVICE FOR LOADING TIES.

It is the practice at the timber treating plant of the Buffalo, Rochester & Pittsburgh at Bradford, Pa., to store the ties that are treated during the winter months and ship them out during the spring as they are required. Previous to this year these ties have been loaded into cars by hand, but the scarcity of laborers during the past season left only enough men to keep the plant in continuous operation and the device described here-



Tie Loading Device With Six Ties.

with was made to handle this material economically in connection with the Brownhoist locomotive crane.

As shown in the illustrations, this device consists essentially of a built up frame with six pairs of arms, six pieces of steel shafting and six coil springs. Two vertical angles on each side of the frame serve as guides for a movable shaft A, to which are fastened six pairs of arms which act as a unit. Each arm is joined independently at B, while the shafts C pass through the slots in the lower arms and are rigidly fastened to the sides

of the frame. The shafts E and D are also rigid and fastened to the frame.

This device is operated on the two-rope plan, the closing and lifting rope being connected to the shaft A and the opening and

from 8 ft. 2 in. to 8 ft. 10 in. in one lift. The opening or discharging of the load is merely the reverse of the closing. The opening rope holds the frame and the shaft A is allowed to drop, bringing the upper arms into contact with the shaft D, which

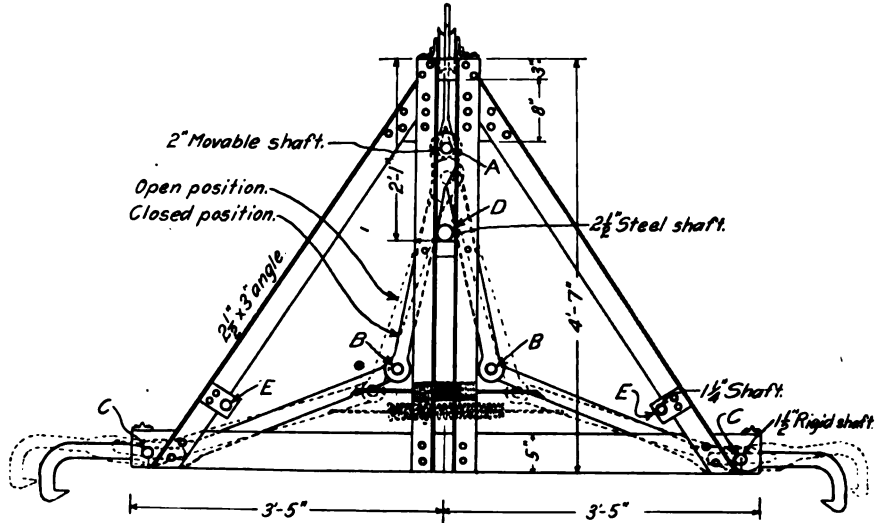
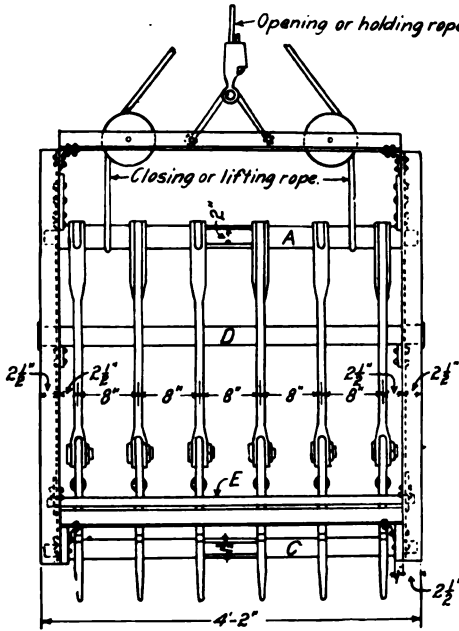

A Device for Loading Ties.

holding rope to the frame. As the shaft A is raised from the open position the springs attached to each lower pair of arms keep the upper arms in contact with the shaft D until the points of the hooks come in contact with the ties, the slots in the lower arms permitting them to slide on the shaft C. After the hooks

forces them apart and the hooks outward allowing the load to drop.

It has been found economical to use three men with this machine, two to guide it on the pile and one in the car. While this device was built because of the scarcity of labor it has been found that it is economical as well in handling the work for which it was designed. Ties had been previously loaded by extra gangs and later by piece workers. While the latter method effected a considerable saving, a further saving of 40 per cent. over the piece work rate was made by the use of this device. It was designed and built under the supervision of G. S. Harden, superintendent of the timber preserving plant of the B. R. & P.



Side View of Tie Loading Device.

come in contact with the ties the shaft A continues to rise until the pair of arms holding the longest tie touch the stops E. The purpose of the springs is not to lift the ties but merely to pull the hooks into contact with them. The stops E are located so that the shaft A will rise to the closed position before the load is lifted, thereby permitting the handling of ties varying in length

### NEW YORK PUBLIC SERVICE COMMISSION STUDYING TRANSVERSE FISSURES IN RAILS.

The failure of rails caused by internal transverse fissures is considered of sufficient importance by the New York Public Service Commission of the Second district to warrant the issuing of a recent order requiring the roads to furnish to the commission an individual report of all rail failures in which this defect is found, whether an accident results from the failure or not. In addition to the information called for on form No. 202, which is to be used for this purpose, it is specified that the following questions shall be answered:

- In what portion of the rail section did the fissure occur?
- What is the size of the fissure?
- Were any other fissures discovered in this rail?
- If so, at what distance from the one first discovered and where located with respect to the gage side of the head?
- Were any other rails situated in the track adjacent to this one removed because of transverse fissures?
- Give small sketch of cross-section showing approximate location of fissure.

It is further ordered that the pieces of broken rails reported under this head are to be held for inspection at a convenient point and are not to be disposed of without the consent of the commission.

# CONCRETE TANKS ON THE BALTIMORE & OHIO.

## Details of Design and Construction of Two 100,000 Gallon Tanks of a Type That Is Receiving Increased Attention.

Concrete water tanks have been the subject of careful study on the part of the operating officials of the Baltimore & Ohio for some time, and experiments conducted for the purpose of determining their practicability have proved satisfactory. As a result two large tanks have been installed, one at Sir John's Run, W. Va., and the other at Chicago Junction, Ohio, both busy watering stations, the former in the eastern territory and the latter in the western section of the system. Other tanks of similar type will probably be built as requirements demand.

The concrete tank at Sir John's Run, which was the first installed, has a capacity of 100,000 gal., with an outside diameter of 25 ft. 10 in. and a total height of 74 ft. from the base of the foundation to the top of concrete under the eaves of the roof, 17 ft. of the base being underground. The tank is cylindrical in design. The bottom of the tank proper is at an elevation of 43 ft. 6 in. above the base of the footing and 30 ft. above the base of the rail. The portion of the tower below the tank floor is divided into a basement and first story, used as a pump room and for storage respectively. The outside diameter of the tank proper is 25 ft. 10 in., the inside diameter at the bottom 24 ft., and it is 30 ft. 6 in. high. The walls of the tank taper on the

extra heavy cast iron except that exposed to water in the tank above the floor, which is of wrought iron.

The foundation slab is 2 ft. 6 in. thick and 33 ft. 6 in. in diameter, reinforced with  $\frac{1}{2}$ -in. cold twisted lug bars, placed radially as shown on the plan, with  $\frac{1}{2}$  in. bars bent circular to act as distributing bars. The radial bars extend from the edge of the slab to points underneath the post or column, which is 7 ft. in diameter at the center of the tower, acting as a support for the tank bottom and as a covering for the pipes. The concrete used for the foundation was a 1:3:5 mixture. According to the designers the maximum pressure on the footing for dead load plus live and wind load on the tower will be one ton per sq. ft., the wind pressure being assumed as a 60 mile per hour gale, or about 20 lbs. per sq. ft. on a diametral section.

The portion of the cylindrical tower below the first floor line is 27 ft. 8 in. outside diameter, extending 17 ft. 6 in. above the top of footing. The walls are of 1:2:4 plain concrete, 2 ft. thick, with a 1 ft. 6 in. x 1 ft. 6 in. fillet placed on both sides of the wall at the footing. At the first floor line the supporting tower is decreased to a 1-ft. wall, of 25 ft. 8 in. outside diameter, reinforced with  $\frac{1}{2}$ -in. bars, spaced 6 in. on centers horizontally, and bent to the radius of wall near the outer surface. The bars are wired to the pipes used for hoisting frames for forms, no vertical bars being used in this portion. Special reinforcement, as shown, is provided for the portions of the wall acting as lintels over the door and window.

The post or column in the center of the tower is of plain concrete 7 ft. in diameter, and acts as a support for the first floor and also for the tank bottom. This post also acts as a support and protection for various supply and discharge pipes. At the bottom of the post is a 1 ft. 6 in. fillet to aid in distributing the load to the foundation.

The first floor at the entrance level is provided with an opening for a stairway to the basement and also with a 6 ft. square hatchway, with a 2-in. plank cover. The first slab is 6 in. thick reinforced with  $\frac{1}{2}$  in. square bars, spaced 8 in. between centers in one direction.

The floor slab spans from the wall to beams 2 in. wide, extending 6 in. below the slab, parallel to a diameter through the hatchway and stair opening. These beams are reinforced with three  $\frac{3}{4}$  in. square bars 24 ft. long. Cross beams of the same depth reinforced with three  $\frac{3}{4}$  in. square bars, 7 ft. long, are placed at the ends of the hatchway and on the side of the stair opening. A 1:1 cement finish was put on the floor before the 1:2:4 concrete of the slab had set.

The slab forming the tank bottom is 8 ft. 8 in. thick at the junction with the shell of the tank, with a slope toward the center for drainage. The reinforcement consists of 32 10-in. 25-lb. I-beams, 9 ft. 8 in. long, placed radially from the wall to the 7-ft. diameter post at the center. At right angles to the I-beams are a series of ten concentric circles of  $\frac{1}{2}$ -in. bars, bent over the top of the I-beams and extending down to a point near the bottom of the slab between the beams. Additional radial reinforcement is provided by placing two  $\frac{1}{2}$ -in. radial bars, wired to the circular bars, between the I-beams and bent up into the tank walls.

The walls of the tank have a thickness of 10 in. at the bottom, tapering on the inside to 7 in. at the top, the outside surface being vertical. The reinforcement consists of horizontal bars bent to the radius of the tank with a sufficient number of vertical bars to support the horizontal bars properly. The vertical bars extend 1 ft. below the bottom of the tank into the supporting walls, while the horizontal bars are varied, a band of eight  $\frac{1}{2}$ -in. bars at  $2\frac{1}{2}$ -in. spacing being placed near the outside of the wall at the bottom of the tank. Above the bottom

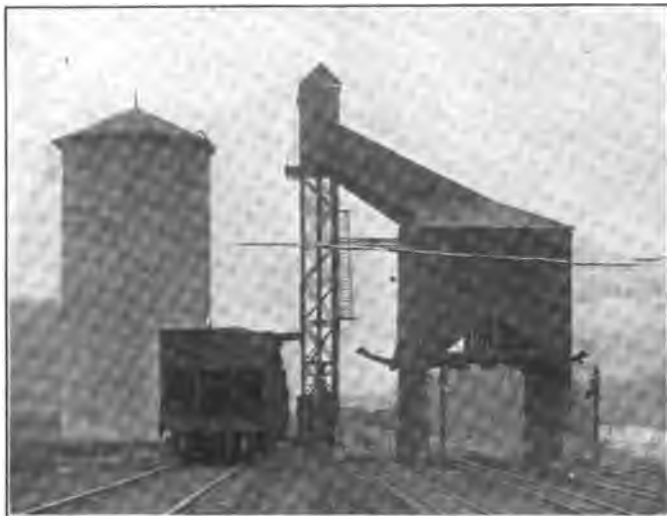

Concrete Tank at Sir John's Run, W. Va.

inside from a thickness of 10 in. at the bottom to seven in. at the top. The available head at the base of rail is 60 ft.

The source of supply for this tank is a reservoir created by a dam across a mountain stream, a short distance from the tank. A 10-in. gravity pipe line from this reservoir conducts the water to the top of the tank, the discharge into the tank being regulated by an automatic float valve. By means of a by-pass connection the 10-in. gravity main can be turned into the 16-in. discharge line and so controlled by valves as to feed into the tank or direct to the two penstocks which are located so as to serve four tracks. By this arrangement the supply is not shut off from the penstocks when sediment is being cleaned out of the tank.

The 16-in. discharge pipe starts at the bottom of the tank, the end being equipped with a cast-iron strainer. In the basement the 10-in. by-pass from the gravity supply previously mentioned is connected by valves to the discharge pipe, which is cut down to 10 in. beyond the first penstock.

A pump with an 8-in. suction pipe to the river nearby affords an auxiliary supply. A 6-in. waste pipe with an inlet at the top of the tank takes care of overflow in case the float valve does not work. This waste pipe has a branch at the bottom of the tank to dispose of sediment when cleaning out. All piping is of

for a distance of 2 ft. 5¼ in. a double circle of ½-in. bars at 4¼-in. spacing is used with a 4½-in. spacing for a double circle of ½-in. bars for 3 ft. above this. Then a section 4 ft. 1 in. in height is reinforced with a double circle of bars with 2½-in. alternate spacing. Above this point is a single circle of ½-in. bars is used with spacing varying from 3 in. to 12 in. near the top.

The unit stress used in the steel for design was 16,000 lbs. per sq. in., no tension to be taken by the concrete. The tank and tower were designed for stresses due to a wind pressure of 20 lbs. per sq. ft. on a diametral section in addition to the dead load of the concrete and the weight of water in the tank. The actual mixture of concrete used was 1:1¾:3½ in order to obtain a very dense mixture, a 1:2:4 mix having been called for in

two coats of Bay Stone cement coating, as made by Wadsworth, Howland & Co., of Boston, Mass. The color for the outside coating to be natural cement or Bedford limestone grey.

"Work shall be arranged so that all concreting shall be completed to stopping points indicated and under no circumstances shall work be stopped below these points. A bond shall be formed at these points around the entire circumference of the previously built wall by thoroughly cleansing it with a stiff wire brush and clean water, and coating the same with a proper mixture of cement, hydrated lime and water; thereafter immediately proceed to concrete and continue until wall forms are filled.

"All reinforcing bars are to be of sizes shown on drawing, but to be material made by the Corrugated Bar Company, of St.

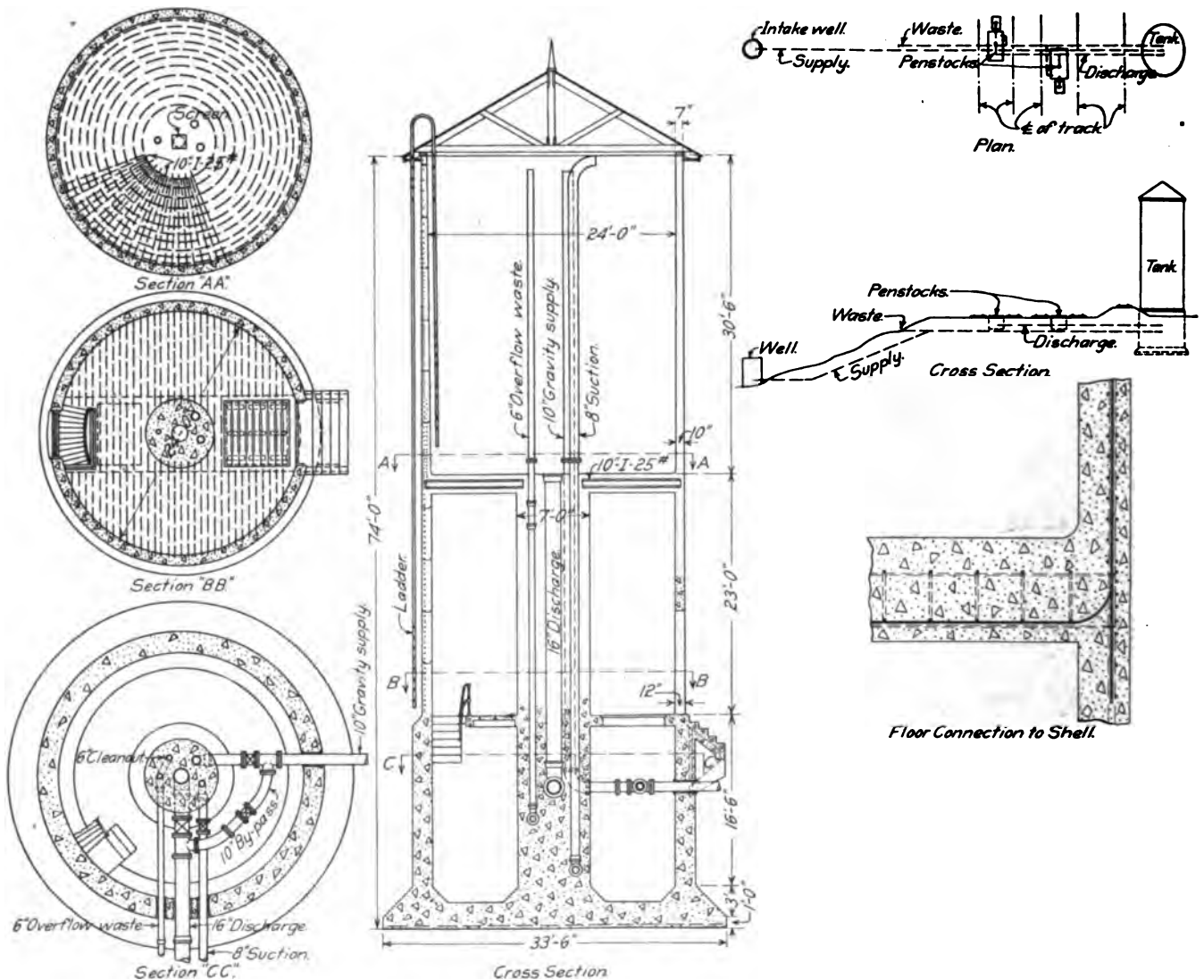

Details of Baltimore & Ohio Concrete Water Tank at Sir John's Run, W. Va.

the specifications. For waterproofing three pounds of hydrated lime was mixed with each sack of cement.

The following extracts from the specifications as to concrete, waterproofing bond and reinforcing steel are of interest.

"The concrete footing course shall be a 1:3:5 mixture. All other concrete shall be a 1:2:4 mixture, thoroughly mixed and carefully placed in the forms. The concrete used is to be a pure Portland cement and to stand all tests as recommended by the American Society for Testing Materials. The sand to be clean and sharp. The coarse aggregate shall be gravel or broken stone in size suitable for the best workmanship.

"Add to the entire concrete mixture a proper percentage of hydrated lime, and the entire inside and outside surface of the tank and the outside of the outer supporting wall is to be given

Louis, Mo., and to be cold twisted lug bars; if bent, they are to be true. Laps are to be at least 30 diameters, and wired to keep them in place with No. 12 annealed wire. Laps shall be staggered. All other reinforcing shall be as shown on the drawing.

"The horizontal circular rods in the tank shall be in two lengths, with a lap of 30 diameters and each lap shall be firmly spliced with one Crosby pattern cable clip, of proper size. Clip splices shall be staggered.

"All reinforcing is to be carefully placed and held rigidly in place while placing concrete. The horizontal and vertical rods are to be thoroughly wired together the entire height of the tank proper, and the rods in the tank bottom are to be bent upwards and clipped to the others. All reinforcing bars are to be of

high carbon steel of a guaranteed elastic limit of 55,000 lbs. per sq. in., and an ultimate strength of 100,000 lbs. per sq. in."

The roof is of wood construction covered with a composition roofing. A 4 in. x 8 in. yellow pine plate of several sections is bolted to the top of the tank wall. Upon this plate is a cross frame composed of four pieces of 3 in. x 8 in. yellow pine framed at right angles to an 8 in. x 8 in. center post, which they support. Eight main rafters of 3 in. x 8 in. yellow pine are framed to the plate and center post. Two 3 in. x 8 in. jack rafters are placed between each two main rafters. A 2 in. x 6 in. fascia is nailed to the ends of the rafters which are cut to form an octagonal roof. Hemlock sheathing, one inch thick, is placed on the rafters and a composition roofing upon this. A hatch in the roof provides access to the interior of the tank by means of an iron ladder extending from the ground to the top of the tank on the outside and to the bottom of the tank on the inside. The tank is also provided with a water depth indicator.

The forms used in the construction of the walls of this tank were of the McCoy patent, self-supporting sheet steel type. They were built in sections 5 ft. 6 in. high, five sections to the circumference, with expansion joints at the connections of the sections. The sections, composed of 3/16-in. steel plates, were reinforced with 3 in. x 3 in. x 3/8-in. angles at the top, bottom and ends. The sections were held with clamps to give a proper thickness of wall, and bolted together at the ends, the bolts passing through holes in the outstanding legs of angles riveted to the ends of the sections.

The forms were raised after a section about 5 ft. 4 in. high was poured (about 2 in. of the bottom forms projecting over the previous section to hold the forms) by means of chains run through differential pulley blocks and fastened to the top of the forms. The pulleys are swung from a cross block at the top of two wrought iron pipes embedded in the concrete previously poured. Two hoists are required for each section of forms.

No staging was required where these forms were used. A platform the size of the inside of the tank was supported by 2 in. x 10 in. timbers, placed radially, resting on the top of the forms, incidentally holding them plumb, and held by a sleeve on an iron pipe at the center. This afforded space enough to carry on concreting and placing the bars. Short ladders were hung on the outside of the forms at the joints of the sections to allow the men to loosen and tighten the joints while raising and setting the forms.

A hoist for concrete was formed by a pulley block and tackle supported by two pipes embedded in the walls and tied to the center pipe. The concrete was hoisted in buckets, by the mixer engine by means of a special hoisting attachment. The concrete was mixed in a Polygon batch mixer operated by a gasoline engine. The sand and crushed stone were shipped in cars, unloaded at the site of the tank and conveyed to the mixer in barrows. The concrete was mixed in such proportions as was found by test to occupy the least volume for a given amount of materials.

After being hoisted to the working platform the concrete was dumped into trough-like boxes with sloping spouts, from which it was shoveled into forms wherever desired.

One 5 ft. 4 in. section of wall was poured each day, the forms being raised, reinforcement placed, the top surface of the concrete treated as described under the specification, and the next section then poured. The center supporting column for the tank bottom was carried up at the same time the walls were being built.

The forms for the tank bottom were so constructed as to allow their keying up after concreting had commenced to avoid the settling of the deck from the compression of the timbers, thereby avoiding displacement of materials or disturbance of the concrete while setting. This deck was left under the tank floor for seven days after placing the concrete.

The capacity of the tank at Chicago Junction is also 100,000 gal. and it is of the same diameter as that at Sir John's Run,

but the height of the tank bottom above the base of the rail is greater, being 50 ft. as against 30 ft. for the latter. The height over-all from the bottom of the concrete foundation, which is 33 ft., 6 in. in diameter, to the top of the tank walls is 93 ft. 6 in. The structure is divided into three stories, the basement being used as a pump room, the second floor for storage, and the third story as the actual tank.

The tanks were designed and constructed under the supervision of F. L. Stuart, chief engineer; and M. A. Long, assistant to the chief engineer, Baltimore & Ohio. The Steel Concrete Construction Company, of Pittsburgh, Pa., which owns the patents on the tank forms and concrete hoists, designed and constructed both tanks.

## SUGGESTIONS FOR SAFETY IN THE MAINTENANCE OF WAY DEPARTMENT.

By B. H. MOON,

Roadmaster, Union Pacific, Rawlins, Wyo.

With the class of men now employed as track foremen, constant supervision on the part of the officers is necessary. If the standard book of rules for the trackmen was followed literally, no doubt 90 per cent. of the accidents would be prevented, but this is a difficult matter to constantly keep before the trackmen, and it therefore becomes the duty of the roadmaster to continually check the men under his supervision to know that there are no violations. In other words, the safety problem in the maintenance of way work resolves itself into the old saying that "eternal vigilance is the price of safety."

In starting the day's work, foremen should see that an inspection is made of all tools, appliances and hand cars so that they can know positively that there are no defects which may result in accidents. This is especially important with reference to defective tools, as many accidents occur because of the men not taking the time to make a few necessary repairs.

The most dangerous practice that we are now confronted with is connected with the handling of rails. In some instances, air operated rail loaders are furnished. In such instances the foremen should see that all working parts are in perfect order before starting work. The cables and rail tongs should be inspected and the stay chains extending from the corner of the car to the boom should be properly adjusted and secured. It is, of course, understood that the men used with this rail loader are organized so that each man knows exactly what is expected of him and performs his part of the work to perfection. Careful attention should be given to see that all rail or other material loaded is placed securely so that there is no danger of its falling from the car when in transit. Another feature of special application in connection with the handling of rail, but more or less true with the handling of other work, is that men should not be shouted at or spoken to in a boisterous and abusive manner, as this has a tendency to excite the more nervous ones and is apt to cause them to do things they would not do under ordinary circumstances.

Foremen, as well as other employees, should obey the rules requiring that no hand cars, push cars, motor cars or other material is left around or on station platforms. This practice is dangerous not only to employees but to passengers as well. Most stations are but poorly lighted and many injuries have occurred by people falling over material or cars left in this manner over night.

Men working on double tracks should clear both tracks in advance of an approaching train. Injuries frequently result from men stepping out of the way of a train on one track in front of one on the other. With a little practice in this direction the men soon become accustomed to it, although unless closely watched they will go back to their old habits. Track jacks should never be placed between the rails as a train may approach before the jack can be removed and an accident result. The foremen should always remain with their men as laborers



do not appreciate safety and are liable to injure themselves or other members of the gang by carelessness.

Foremen should be very particular when flagging trains and should know absolutely that the man assigned to protect a gang of men working on unsafe track is competent to perform this duty to the letter. The proper inspection of unsafe track should also be carefully watched by the foremen so that an accident will not occur because of defective or rough track. He cannot be too careful in the matter of issuing slow orders or protecting unsafe track with slow orders.

Hand or motor cars should not be run without members of the gang facing each direction so that the approach of a train will be noticed by some member of the crew in time to remove the car with safety. I believe that wherever available, the facts regarding accidents should be given to the men in the way of bulletins pointing out just how the accidents could have been prevented. This, no doubt, will have a tendency to cause the foremen to notice things of a similar nature if they exist on their sections.

### SIMPLE METHOD OF OBTAINING TIME AND AZIMUTH.

By J. A. MACDONALD,

Topographical Surveys Branch, Ottawa, Ontario.

The usual method of obtaining azimuth from Polaris is by making observations at elongation. While the following method is not new it is not generally known and will be found much simpler in application and fully as accurate as the elongation method. No instrument is required and no nautical almanac or mathematical tables are needed.

This method is based on the fact that Polaris and two adjacent bright stars are in the same vertical plane only a

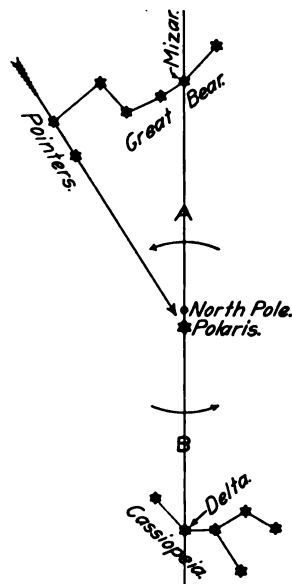

Relative Location of Polaris and Adjacent Constellations, Showing Vertical Line Through Three Stars for Determination of Azimuth.

few minutes before Polaris crosses the meridian. It can be used at only one moment in each 24 hours and it requires a fairly clear sky to enable the stars to be sighted behind a plumb line. The two stars that can be used in this observation are Mizar, the middle star in the tail or handle of the constellation known as the Great Bear or the Dipper, and Delta in the constellation Cassiopeia, commonly known as the Little Dipper. The former can be used only when it is below the pole during the night. When it passes the meridian above the pole it is too near the zenith to be of service, in which case the latter star is observed. The accompanying

diagram shows the principal stars of the constellations of Cassiopeia and the Great Bear with Delta Cassiopeia, Mizar and Polaris on the meridian. The following tables show the exact time at which these stars are in the same vertical plane on given dates. The time for other days can be secured by direct interpolation, the daily variation being four minutes. From January to June the observation is made with Mizar, and from July to December with Delta Cassiopeia.

	On line.		On line.
January 20 .....	5:22 a. m.	July 20 .....	5:30 a. m.
February 20 .....	3:20 a. m.	August 20 .....	3:28 a. m.
March 20 .....	1:30 a. m.	September 20 .....	1:26 a. m.
April 20 .....	11:24 p. m.	October 20 .....	11:24 p. m.
May 20 .....	9:26 p. m.	November 20 .....	9:22 p. m.
June 20 .....	7:24 p. m.	December 20 .....	7:24 p. m.

When it has been determined by observation that Polaris is in the same vertical plane with one of these stars it can be shown that it will pass the meridian 7.15 minutes later during 1913. This interval is increasing from year to year at the rate of 0.33 minutes so that in 1914 the interval will be about 7.5 minutes. The observation can be made either indoors or out by suspending an ordinary plumb line and marking the direction of the meridian by setting a second point at the stated interval after the two stars are in the same vertical plane.

The same observation may be used to determine local standard time by the use of the accompanying tables for time, adding four minutes for each degree if the place of observation lies west of the time meridian and subtracting the same for stations east of the meridian.

### A NOVEL AND EFFECTIVE CATTLE GUARD.

A type of cattle guard which is being used to a limited extent on the Arizona Eastern is probably the simplest and cheapest cattle guard ever constructed, and its efficiency is said to be even superior to much more elaborate and expensive types. The first one of these guards was put in service about six months ago, and it is said that no animal has ever crossed it or shown the slightest desire to investigate it, as it consists simply of a bed of



A Cactus Cattle Guard.

a small cactus that grows abundantly along that portion of the line and with whose thorns horses and cattle are thoroughly familiar. It is said that horses will shy from a patch of this cactus as they would from a rattlesnake. The bed is made, as the accompanying photograph indicates, of 2 in. x 6 in. timbers placed on edge. In the bottom of the box so formed is placed a few inches of sand and gravel in which the cactus is planted. This variety of cactus is said to be very long lived, and as the material grows in abundance nearby, it is not difficult to renew it if necessary. As the thorns will pierce an ordinary boot or shoe, it is necessary to place a piece of timber along the bottom bar of the fence of the guard to allow employees to cross. This cattle guard was devised by Arthur Moeller, foreman of section 8 at Fort Thomas, Ariz.

# MAKING SECTION FOREMEN FROM CLERKS.

A Unique Plan for Providing Competent Section Foremen by Utilizing Promising Young Men Who Now Leave the Service.

BY WILLIAM S. WOLLNER.

In submitting this plan for providing section foremen from a heretofore untried source the originator has accepted without question the statements of officials of the track department that section, yard and extra gangs do not produce a sufficient number of men capable of assuming the duties of foremen to permit of all such positions being filled by the promotion of men already employed in the track department; that section foremen who have been promoted from among the laborers in section, yard and extra gangs are to a large extent inefficient; and that section foremen of foreign birth are not suited to the needs of American railroads.

The acceptance of these facts leads to the conclusion that it is useless to further investigate the track department as a possible source for the production of future foremen and that some plan for the educating of men who are to become foremen must be devised in order that men may be placed in charge of the maintenance units who are fully alive to the responsibilities resting upon them and of the economic efficiency it is possible for them to create by skilful management of the few miles of track placed under their immediate charge.

The need for providing more efficient section foremen in greater numbers than are now available having been brought to the writer's attention while he has under investigation possible means for the creation of greater efficiency in the conduct of executive and general offices, has caused him to consider these two problems with relation to each other, and has resulted in the presentation of this report, which does to a certain extent bear upon both questions now under investigation.

The executive and general offices of the company under consideration give employment to about 1,500 persons, all of whom are employed in one building situated in the heart of the business district of a city of 450,000 inhabitants. While the organization of the forces of the different departments changes from time to time it may be assumed that the general strength is as follows:

Female employees (stenographers, clerks, ticket counters, way-bill sorters, etc.).....	500
Experienced male clerks (chief clerks, secretaries, heads of bureaus, heads of desks, statisticians, accountants, etc.)..	180
Ordinary male clerks (stenographers, clerks working under the direct supervision of other clerks, messengers, etc.)..	670
Boys (between the ages of 15 and 19 years).....	150

Boys usually enter the employ of the railroad at the age of 15 years, the compulsory education law prohibiting their employment before that age. In order to maintain this force of 150 boys it is necessary to take twice that number into the service each year. About 50 of the boys taken into the service during a given year are promoted to clerical positions and the other 250 leave the service. The entrance salary is \$25 to \$30 per month, which increases to \$60 to \$65 after four or five years' service. No fixed schedule is maintained, the salary being regulated largely by the duties the boy is called upon to perform.

Although apprentice courses are now provided for boys working in the shops, in telegraph offices, etc., no effort is made to educate or train boys who enter the general office service, it being assumed that they will absorb sufficient knowledge of general office work from their surroundings; from contact with men who are performing the work they will later be called upon to do, and from brief instruction as to their new duties as they are advanced from one position to another. No attention is given to the advancement of their scholastic education, or to their physical or moral welfare. Briefly; a boy is taken into the organization with the understanding that he will either be promoted to a clerkship in his regular turn or that he will leave the service before his turn is reached; if he stays in the

organization the schooling he has already received, supplemented by the knowledge of his duties which he will gain through contact with the work he is called upon to perform, will be sufficient to enable him to render any service he may be called upon for during the term of his employment with the company.

Office work does not generally appeal to a boy. He accepts it as a means of earning a living during his youth, but it is seldom that a boy will admit a desire to spend his maturity in an office. Practical railroading does appeal to boys; take a normal boy through the shops or the yards and you will see his entire interest centered in what is going on about him. The experience of the writer has been that when a boy has once been introduced to the mysteries of railroading (on the road) he will usually express a desire to enter it as a life pursuit. In contradistinction to this the boy sees in the general offices men who have given the best part of their lives to the service of the company, their only return being a stunted physique and a very moderate financial return for their labor; and there are no stories of railroad presidents who have risen to fame via the general office route to hold a boy to his task when the opportunity for more interesting work outside the railroad field presents itself.

It has been the experience of accounting and other general officials that men inexperienced in railroad office work are very easily trained to perform the duties required of the clerks in the general offices and that it is not necessary to depend upon promotion to fill most of the vacancies that occur. This, of course, applies only to employees termed "ordinary clerks," it being understood that a considerable length of service is required before men can be placed in the class of "experienced clerks."

Under the present system of railway organization it may be said that the section gang and the general office form the two extremes of the service. The section man is in direct daily contact with the actual operation of the road, while the general office clerk is usually far removed from the scene of operation and is not in any way directly connected with the act of supplying transportation. To consider these two far-separated branches of the service with the idea of improving one or both by providing desirable material from the personnel of the other is unusual, and as far as the writer has been able to ascertain, original; but an observation of both branches of the service during some years of intimate connection with the track department and the general office leads him to believe that the task is not impossible.

The suggested plan is that apprentice courses leading to positions as section men be established in order that a sufficient number of properly trained young men may be available from which selection may be made to fill vacancies as they occur, but that instead of classes being conducted on the road where the subject presented has its practical application, that they be an adjunct to the general offices so that boys employed there may avail themselves of the opportunity to acquire sufficient theoretical knowledge of railroading to permit of their entering the operating department through the medium of the section gang.

The course would, of necessity, have to be divided into two parts, that which could be conducted in the class-room and that which must be taught on the road, and it is with this idea in mind that the writer has taken advantage of the presence of available material in the general offices from which to draw students, it being assumed that by the time this course was completed the instructor would have had sufficient opportunity to determine whether a young man was of the type from which

it is possible to produce successful foremen. For the purpose of this preliminary plan it is assumed that five hours a week for one year would constitute the first, or theoretical, part of the course and that eight hours a day for six months would be required for the second, or practical part.

No boy should be selected as an apprentice until he had passed his eighteenth birthday and has been at least two years in the company's service. He should be recommended as an apprentice by the official under whom he is employed and his physical qualifications should be certified to by the company's surgeon before he is admitted to the course. It might be found advisable to require candidates to pass a mental, or educational, test in addition to the above. In any event no boy should be admitted to the classes until it had been fully determined that he was in every way qualified to properly perform the duties of a section foreman.

Classes should be held during the early morning hours, so that the students would not be fatigued by their regular work. The first subject taught should be "section mathematics," which should include all the special arithmetic that it is necessary for a foreman, supervisor or roadmaster to know. Determining the degree of curve, turnout angle, frog number, etc., should be important parts of this subject, as should also be the theory of simple trusses. After the mathematical course is completed "section accounting" should be taught and stress should be laid upon how the keeping of proper accounts assists the foreman, as well as the official, in determining whether he is doing his work in the most efficient and economical manner. The use of roadway reports in the division and general offices should be explained and illustrated. Visits with the instructor to offices where these reports are used will serve to illustrate their value in a very effective manner, and to impress upon the student the necessity for their being properly submitted.

The manufacture and care of tools and material should next follow. Proper attention to this part of the course will prevent much abuse to rail and fastenings, improper handling of creosoted timber, etc., which now occur through the ignorance of the foreman. The manufacture of tools and tool sharpening should be introduced also, and visits should be made to foundries and machine shops in order that the boys may learn how the various tools and material used on the section are made.

The success or failure of this plan will depend more upon the selection of the instructors than upon any other single thing. A man who combines a knowledge of practical railroad work with a knack of keeping boys interested in their studies, as well as the ability to teach the necessary subjects should be obtained for the class-room work; a young, energetic roadmaster or assistant roadmaster should be selected for teaching the practical branches. Their work should be supplemented by frequent talks by officials and others on special subjects, and all officials and employees should be subject to call for this work. Any boy who does not show the proper interest in his studies or who does not, through fault of his own, regularly attend classes and perform the work required of him outside of office and class hours should be promptly dropped from the company's service. Heads of offices and departments should be made to understand the importance of boys attending classes regularly and should assist the instructors in every possible way.

A section close to town and easily reached by street car (so that the boys might still live at home) should be reserved for instruction purposes, and when a boy had completed his class-room work he should be assigned to the gang on this section. Boys should be required to report for duty at eight in the morning and quit at five in the evening, and be allowed an hour in the middle of the day for lunch. This section gang should be made up entirely of apprentices and, as stated above, should be in charge of the best roadmaster or assistant roadmaster that the road can produce. It is of the utmost importance that he be in entire sympathy with the object sought, and it is desirable that he be a technical graduate. Six months' service under such a man, together with the occasional night classes and

lectures that he would be required to attend should make a first-class section laborer out of any boy. If he started his apprenticeship when he was 18 he would be nearly 20 years old when he finished his course on this section, and although this is much younger than our present foremen, youth should increase his efficiency rather than detract from it. A boy who has spent 18 months at hard study and labor is more likely to regard his work as something of especial importance to himself and to the company than is a foreman who is merely working for the small wage paid for this class of work.

A few sections adjoining the apprentice section should be manned with regular section laborers, but the foremanship should be reserved for graduates of the apprentice section. Here the young foreman would still be under the eye of the instructor and would have him to appeal to in case of need. Some such steadying influence would be very much needed when an apprentice was first given authority over others, and the foremanship of these sections would form a very desirable intermediary between the apprentice section and the section that he would eventually have charge of out on the road.

While a boy is attending classes he should be paid at the same rate as other boys doing the same work and not attending classes. No deduction should be made for the time he is in classes, nor for instruction or supplies. While upon the experimental section he should be paid at the same rate as is paid regular section laborers, and when he is placed in charge of a section at the same rate paid other section foremen. After the first year, however, his rate should be advanced \$5 per month, and a similar increase should be made every third year thereafter until he reaches a rate of \$90 per month. This will be after eight years, so the boy will now be 29 years old. The fact that there are not many men 29 years old in the general offices who are earning \$90 per month, house rent, fuel, light and water, together with the physical benefit that will accrue to the boy, is all that need be said about the social aspect of this plan. There is also the further probability that if he possesses the proper ability a boy will have advanced to the foremanship of an extra gang or have become a roadmaster by this time and that he will continue up the official ladder to assistant superintendent, superintendent, and to the final height that his ability makes possible.

This plan is presented merely as a preliminary report, and much careful thought and study will have to be given to this subject before it can even be given a trial. It is understood that after the experiment has started many changes will have to be made to fit it to conditions that are bound to arise and that many boys who will be enrolled as apprentices will not complete their courses, or if they do complete them will not prove satisfactory foremen. But that the experiment is worth a trial is based upon the facts that competent foremen are very badly needed in greater numbers than are now available, that most of the other schemes for providing competent foremen have failed, and that this plan provides for the training of roadway officials along scientific lines which should tend toward the more efficient operation of the railroad as a whole.

**RAISING TRACK OR BUILDING TRESTLE.**—In making the embankments for the track elevation work of the New York, Chicago & St. Louis in Cleveland, as described by A. J. Himes, engineer of grade elimination in Bulletin No. 160 of the American Railway Engineering Association, the tracks were raised by jacking up on the fill rather than building temporary trestles, after making an estimate of costs. The embankment to be built was about 2,080 ft. long with an average depth of 13 ft. and contained 40,000 cu. yds. of material. The trestle would have cost not less than \$9.40 per ft. or a total of \$19,552. Assuming a credit of \$3.25 per ft. for stringers and ties and deducting this total of \$6,760, the net cost of the trestle would have been \$12,792. The cost for labor used in making the fill by raising was \$0.10 per cu. yd., or a total of \$4,000, which is less than one-third the estimated cost of the trestle.

**THE BRANDING AND HEAT NUMBER STAMPING OF STEEL RAILS.**

At this time when increased attention is being given to the compilation of accurate records of rails, especially failed rails, the following information concerning the methods of branding and stamping the heat numbers at the various mills, prepared by Robert W. Hunt & Company, and published in a small booklet by the Railway Supply Company, Chicago, will be of interest.

The brand on rails gives the name of the manufacturer, a number or abbreviation by which the rail section is designated, the month and year of manufacture, and if the metal is open hearth steel, the letters "O. H." are also added. Sometimes the letters "F. T." are added to signify ferro-titanium steel. Square block letters and figures about an inch high are commonly used, and as these are cut into one of the rolls of the last pass, the brand will always appear slightly raised at regular intervals on

the rail length, or it may be shown only once or twice, according to mechanical conditions of the mill.

The letter showing the position of the rail in the ingot is sometimes stamped on by hand, in which case a die is held on the web and struck with a hammer, but generally it is applied by the same or another machine that stamps the heat number. Of course, if the dies become worn or slightly twisted, the figures and letters are bound to be indistinct.

The following is intended to serve as a guide for correctly locating and reading heat numbers and letters and gives the practice employed at each rail mill.

*Algoma Steel Company.*—Bessemer heat numbers contain from one to five figures and open hearth heat numbers generally contain four figures. These numbers are stamped at least three times on the unbranded side of the rail. The mill does not make a practice of adding the rail letter.

*Bethlehem Steel Company.*—There are always five figures in

Lackawanna Steel Company				
Section No.	Wt. Rail	Base Inches	Height Inches	Tread Inches
600	60*	4 1/4	4 1/4	2 3/4
600-X	60	4 1/4	4 1/4	2 3/4
650	65*	4 1/2	4 1/2	2 3/4
653	65	4 1/2	4 1/2	2 3/4
654	65	4 1/2	4 1/2	2 3/4
700	70*	4 3/4	4 3/4	2 3/4
701	70	4 3/4	4 3/4	2 3/4
721	72	4 3/4	4 3/4	2 3/4
722	72	4 3/4	4 3/4	2 3/4
741	74	4 3/4	4 3/4	2 3/4
750	75*	4 1/2	4 1/2	2 3/4
752	75	5	5	2 3/4
753	75	5	4 1/2	2 3/4
754	75	4 3/4	4 3/4	2 3/4
775	77.5	5	5	2 3/4
781	78	5	4 3/4	2 3/4
798	79	5 1/4	5	2 3/4
800	80	5	5	2 3/4
801	80	5	5 1/4	2 3/4
802	80	5	5	2 3/4
8031	80†	4 3/4	4 3/4	2 3/4
8032	80†	4 1/2	4 1/2	2 3/4
804	80	5	5	2 3/4
817	81	6	7	2 3/4
850	85*	5 1/4	5 1/4	2 3/4
851	85	5 1/4	5 1/4	2 3/4
852	85	5	5	2 3/4
853	85	5 1/4	5 1/4	2 3/4
8530	85	4 3/4	5 1/4	2 3/4
8531	85	4 1/2	5 1/4	2 3/4
855	85	5 1/4	5 1/4	2 3/4
900	90*	5 1/4	5 1/4	2 3/4
901	90	5	5 1/4	2 3/4
902	90	5	5	2 3/4
903	90	5 1/4	5 1/4	2 3/4
9030	90	5	5 1/4	2 3/4
9031	90†	5 1/4	5 1/4	2 3/4
9032	90†	4 1/2	5 1/4	2 3/4
9033	90	5 1/4	5 1/4	2 3/4
911	91	5 1/4	5 1/4	2 3/4
951	95.4	5 1/4	5 1/4	3
957	95	6	7 1/2	3
1000	100*	5 1/4	5 1/4	2 3/4
1001	100	5 1/4	6	3
1002	100	5 1/4	6	2 3/4
1003	100	5 1/4	5 1/4	2 3/4
1030	100	5	5 1/4	2 3/4
1031	100†	5 1/4	6	2 3/4
1005	100	5 1/4	5 1/4	2 3/4
10130	101	5 1/4	5 1/4	2 3/4
1051	105	5 1/4	6	3

Cambria Steel Company				
Section No.	Weight Rail	Base Inches	Height Inches	Tread Inches
514	60	3 3/4	4	2 1/2
509	60	4 1/4	4 1/4	2 3/4
527	60	4 1/4	4 1/4	2 3/4
571	60†	3 1/2	4 1/4	2 3/4
568	60†	4	4 1/4	2 3/4
533	60*	4 1/4	4 1/4	2 3/4
518	65	4 1/4	4 1/4	2 3/4
534	65*	4 1/4	4 1/4	2 3/4
515	67	4 1/4	4 1/4	2 3/4
547	66	4 1/4	4 1/4	2 3/4
516	68	4 1/4	4 1/4	2 3/4
532	70*	4 1/4	4 1/4	2 3/4
504	70 and 72	4 1/4	4 1/4	2 3/4
570	70†	4 1/4	4 1/4	2 3/4
567	70†	4 1/4	4 1/4	2 3/4
528	75	4 1/4	4 1/4	2 3/4
529	75*	4 1/4	4 1/4	2 3/4
530	80*	5	5	2 3/4
540	80	4 1/2	5	2 3/4
543	80	5	5 1/4	2 3/4
569	80†	4 1/4	4 1/4	2 3/4
566	80†	4 1/4	5 1/4	2 3/4
506	85	5	5	2 3/4
500	85	5	5	2 3/4
531	85*	5 1/4	5 1/4	2 3/4
559	85	4 1/4	5 1/4	2 3/4
561	90†	4 1/4	5 1/4	2 3/4
563	90†	5 1/4	5 1/4	2 3/4
535	90*	5 1/4	5 1/4	2 3/4
550	95*	5 1/4	5 1/4	2 3/4
558	100	5	5 1/4	2 3/4
520	100	5 1/4	5 1/4	2 3/4
564	100†	5 1/4	5 1/4	2 3/4
565	100†	5 1/4	6	2 3/4
538	100*	5 1/4	5 3/4	2 3/4
572	110	5 1/4	6	2 3/4
573	120	5 3/4	6 1/4	2 3/4
574	130	6	6 1/2	2 1/2

Dominion Iron & Steel Company				
Section No.	Wt. Rail	Base Inches	Height Inches	Tread Inches
6001	60	4 1/4	4 1/4	2 3/4
6501	65	4 3/4	4 3/4	2 3/4
7001	70	4 3/4	4 3/4	2 3/4
7501	75	4 1/2	4 1/2	2 3/4
8001	80	5	5	2 3/4
8002	80	5	5 1/4	2 3/4
8003	80	5	5	2 3/4
8501	85	5	5 1/4	2 3/4
10001	100	5 3/4	5 3/4	2 3/4

Colorado Fuel & Iron Company				
Section No.	Wt. Rail	Base Inches	Height Inches	Tread Inches
603	60*	4 1/4	4 1/4	2 3/4
653	65*	4 1/2	4 1/2	2 3/4
701	70*	4 3/4	4 3/4	2 3/4
753	75*	4 1/2	4 1/2	2 3/4
784	75	5	5	2 3/4
786	75	4 3/4	4 3/4	2 3/4
787	75	4 1/4	4 1/4	2 3/4
800	80*	5	5	2 3/4
801	80†	4 3/4	5 1/4	2 3/4
850	85	5 1/4	5 1/4	2 3/4
851	85*	5 1/4	5 1/4	2 3/4
852	85	5 1/4	5 1/4	2 3/4
853	85	4 3/4	5 1/4	2 3/4
900	90*	5 1/4	5 1/4	2 3/4
902	90†	5 1/4	5 1/4	2 3/4
903	90	5 1/4	5 1/4	2 3/4
904	90	5	5 1/4	2 3/4
905	90†	4 1/4	5 1/4	2 3/4
950	95*	5 1/4	5 1/4	2 3/4
1000	100*	5 3/4	5 3/4	2 3/4
1002	100†	5 1/4	5 1/4	2 3/4
1100	110*	6 1/4	6 1/4	2 3/4

\*Indicates ASCE section rails.  
†Indicates ARA series A section rails.  
‡Indicates ARA series B section rails.

the web of the rail. The month is generally shown by Roman numerals, as VII for July, and sometimes by a series of 1's, as 11111 for May.

The number representing the heat, blow or melt of steel, and the letter to indicate the position of the rail in the ingot, is stamped on the web of the rail with dies while it is still red hot, but after it has been completely rolled and sawed to length. All mills except Pennsylvania and Colorado stamp the heat number and letter on the side of the web which does not carry the brand. Remembering also that the brand always appears in raised letters, and that the heat number and letter is stamped on, no confusion of the two should exist. Except at the Lorain mill, the heat number is always applied by dies carried on a wheel which revolves, so that when brought into contact with the moving rail, the numerals on the face of the dies are stamped on the web. It may be repeated, therefore, several times on

the heat number, which is stamped at least once on the unbranded side of the rail, generally near the center. Sometimes there is a letter in front of the heat number to indicate a furnace, and this should not be confused with the rail letter, which follows the heat number and is stamped by the same machine. Typical stamping would be B18495 C, which would mean the C rail from this particular heat and furnace.

*Cambria Steel Company.*—Bessemer heat numbers may contain from one to five figures, and open hearth heats always contain five figures. These numbers are stamped at least twice on the unbranded side of the rail. The rail letter is stamped by a separate machine, so that it usually appears about six times on the rail length, and can be easily located.

*Carnegie Steel Company (Edgar Thompson Works).*—Bessemer heat numbers may contain from one to five figures, and open hearth heats always five figures. These numbers are

stamped at least three times on the unbranded side of the rail, but the rail letter is stamped on by hand, generally twice near one end, so that it will be near the joints.

*Colorado Fuel & Iron Company.*—There are from one to four figures in the heat number, which is stamped at least twice on the branded side of the rail. The branding and stamping may

come together and cause some confusion. The rail letter is stamped on by hand at least once near one end of the rail, so that it will be near the joints.

*Dominion Iron & Steel Company.*—There are always four figures in the heat number, which is stamped at least twice on the unbranded side of the rail. The rail letter is stamped on

Tennessee Coal & Iron Company					
Sec. Nos.		Wt. Rail	Base Inches	Height Inches	Tread Inches
Old	New				
600	6040	60*	4 1/4	4 1/4	2 3/4
650	6540	65*	4 1/4	4 1/4	2 3/4
700	7040	70*	4 1/4	4 1/4	2 3/4
702	702	70*	4 1/4	4 1/4	2 3/4
750	7540	75*	4 1/4	4 1/4	2 3/4
752	7523	75	5	5	2 3/4
753	.....	75	5	5	2 3/4
754	.....	75	4 1/2	4 1/2	2 3/4
755	.....	75	4 1/2	4 1/2	2 3/4
800	8040	80*	5	5	2 3/4
850	8540	85*	5 1/2	5 1/2	2 3/4
854	.....	85	5	5 1/2	2 3/4
855	.....	85	5 1/2	5 1/2	2 3/4
900	9040	90*	5 3/4	5 3/4	2 3/4
901	9023	90	5 3/4	5 3/4	2 3/4
902	9020	90†	5 3/4	5 3/4	2 3/4
903	9030	90†	4 3/4	5 3/4	2 3/4
904	.....	90	5 3/4	5 3/4	2 3/4
1500	.....	150	6	6	4 1/4

Pennsylvania Steel Company					
Section No.	Wt. Rail	Base Inches	Height Inches	Tread Inches	
6	60	4 1/4	4 1/4	2 3/4	
244	60*	4 1/4	4 1/4	2 3/4	
71	60†	4 1/4	4 1/4	2 3/4	
166	61	4 1/4	4 1/4	2 3/4	
236	65*	4 1/4	4 1/4	2 3/4	
117	65	4 1/4	5	2 3/4	
145	66	4 1/2	4 1/2	2 3/4	
112	66	4 1/2	4 1/2	2 3/4	
2	67	4 1/2	4 1/2	2 3/4	
62	68	4 1/2	4 1/2	2 3/4	
68	68	4 1/2	4 1/2	2 3/4	
113	68†	4 1/2	4 1/2	2 3/4	
57	70	4 1/2	4 1/2	2 3/4	
46	70	4 1/2	4 1/2	2 3/4	
97	70	4 1/2	4 1/2	2 3/4	
237	70*	4 1/2	4 1/2	2 3/4	
146	74	4 1/2	4 1/2	2 3/4	
87	75	4 1/2	4 1/2	2 3/4	
289	75	4 1/2	4 1/2	2 3/4	
128	75	5	5	2 3/4	
92	75	5	5	2 3/4	
249	75	5	5	2 3/4	
221	75	5	5	2 3/4	
214	75*	4 1/2	4 1/2	2 3/4	
248	75	4 1/2	4 1/2	2 3/4	
216	76	5	5	2 3/4	
98	78	5	5	2 3/4	
76	79	4 1/2	4 1/2	2 3/4	
220	80	5 1/2	5 1/2	2 3/4	
171	80†	5 1/2	5 1/2	2 3/4	
114	80	5	5	2 3/4	
73	80	5	5	2 3/4	
169	80†	4 3/4	5 1/2	2 3/4	
251	80*	5	5	2 3/4	
119	83†	5	5	2 3/4	
67	85	5	5	2 3/4	
156	85	4 1/2	5 1/2	2 3/4	
261	85	5	5 1/2	2 3/4	
172	85	4 1/2	5 1/2	2 3/4	
67-A	85	4 1/2	5 1/2	2 3/4	
235	85*	5 1/2	5 1/2	2 3/4	
111	85	4 1/2	5 1/2	2 3/4	
77	90	5	5	2 3/4	
160	90	5	5 1/2	2 3/4	
173	90	5 1/2	5 1/2	2 3/4	
162	90†	5 1/2	5 1/2	2 3/4	
170	90†	5 1/2	5 1/2	2 3/4	
245	90*	5 1/2	5 1/2	2 3/4	
147	90	5 1/2	5 1/2	2 3/4	
90	100	5 1/2	6	2 3/4	
100	100	5 1/2	6	2 3/4	
98-A	100	5	5 1/2	2 3/4	
165	100	5 1/2	5 1/2	2 3/4	
116	100	5 1/2	6	3	
163	100†	5 1/2	6	2 3/4	
247	100†	5 1/2	5 1/2	2 3/4	
161	100†	5 1/2	5 1/2	2 3/4	
299	101	5 1/2	5 1/2	2 3/4	
290	135	6	6 1/2	3 1/4	

Illinois Steel Company					
Sec. Nos.		Wt. Rail	Base Inches	Height Inches	Tread Inches
Old	New				
6001	6051	60	4 1/4	4 1/4	2 3/4
6007	.....	60	4 1/4	4 1/4	2 3/4
6008	.....	60	4 1/4	4 1/4	2 3/4
6009	.....	60	4 1/4	4 1/4	2 3/4
6012	.....	60	4 1/4	4 1/4	2 3/4
6013	.....	60	4 1/4	4 1/4	2 3/4
6014	.....	60	4 1/4	4 1/4	2 3/4
6015	6040	60*	4 1/4	4 1/4	2 3/4
6017	6033	60	4 1/4	4 1/4	2 3/4
6020	.....	60†	4 1/4	4 1/4	2 3/4
6030	.....	60†	3 1/2	4 1/4	2 3/4
6101	.....	61	4 1/4	4 1/4	2 3/4
6301	.....	63	4 1/4	4 1/4	2 3/4
6501	.....	65	4 1/4	4 1/4	2 3/4
6503	.....	65	4 1/4	4 1/4	2 3/4
6504	.....	65	4 1/4	4 1/4	2 3/4
6506	.....	65	4 1/4	4 1/4	2 3/4
6507	6540	65*	4 1/4	4 1/4	2 3/4
6508	.....	65	4 1/4	4 1/4	2 3/4
6601	.....	66	4 1/4	4 1/4	2 3/4
6602	.....	66	4 1/4	4 1/4	2 3/4
6603	.....	66	4 1/4	4 1/4	2 3/4
6701	.....	67	4 1/4	4 1/4	2 3/4
6702	.....	67	4 1/4	4 1/4	2 3/4
6703	.....	67	4 1/4	4 1/4	2 3/4
6704	.....	67	4 1/4	4 1/4	2 3/4
6705	.....	67	4 1/4	4 1/4	2 3/4
6706	6733	67	4 1/4	4 1/4	2 3/4
6801	.....	68	4 1/4	4 1/4	2 3/4
7002	.....	70	4 1/4	4 1/4	2 3/4
7003	.....	70	4 1/4	4 1/4	2 3/4
7005	7033	70	4 1/4	4 1/4	2 3/4
7006	.....	70	4 1/4	4 1/4	2 3/4
7007	.....	70	4 1/4	4 1/4	2 3/4
7008	.....	70	4 1/4	4 1/4	2 3/4
7009	.....	70	4 1/4	4 1/4	2 3/4
7010	7040	70*	4 1/4	4 1/4	2 3/4
7011	.....	70	5 1/2	4 7/8	2 3/4
7013	.....	70	4 1/4	4 1/4	2 3/4
7014	.....	70	4 1/4	4 1/4	2 3/4
7020	.....	70†	4 1/4	4 1/4	2 3/4
7030	.....	70†	4 1/4	4 1/4	2 3/4
7101	.....	71	4 1/4	4 1/4	2 3/4
7102	.....	71	5 1/2	4 1/4	2 3/4
7103	.....	71	4 1/4	4 1/4	2 3/4
7201	7250	72	4 1/4	4 1/4	2 3/4
7202	.....	72	4 1/4	4 1/4	2 3/4
7203	.....	72	5	6	2 3/4
7204	.....	72	4 1/4	4 1/4	2 3/4
7301	.....	73	4 1/4	4 1/4	2 3/4
7502	.....	75	4 1/4	4 1/4	2 3/4
7503	.....	75	4 1/4	4 1/4	2 3/4
7505	.....	75	4 1/4	4 1/4	2 3/4
7506	7540	75*	4 1/4	4 1/4	2 3/4
7507	.....	75	5	5	2 3/4
7508	.....	75	5	5 1/2	2 3/4
7509	.....	75	5	5 1/2	2 3/4
7512	7550	75	4 1/4	4 1/4	2 3/4
7513	7523	75	5	5	2 3/4
7514	.....	75	4 1/4	4 1/4	2 3/4
7524	.....	75	4 1/4	4 1/4	2 3/4
77501	.....	77 1/2	5	5	2 3/4
7801	.....	78	5	5 1/2	2 3/4
8001	.....	80	5	5	2 3/4
8002	.....	80	5	5	2 3/4
8003	.....	80	4 3/4	5	2 3/4
8004	8040	80*	5	5	2 3/4
8005	.....	80	5	5	2 3/4
8008	8022	80	5	5 1/2	2 3/4
8009	.....	80	5	5	2 3/4
8010	.....	80	5	5	2 3/4
8020	.....	80†	4 3/4	5 1/2	2 3/4
8030	.....	80†	4 1/4	4 1/4	2 3/4
8501	.....	85	4 1/4	5	2 3/4
8502	.....	85	5	5 1/2	2 3/4
8503	8533	85	5	5	2 3/4
8504	8540	85*	5 1/2	5 1/2	2 3/4
8506	8543	85	5 1/4	5 1/2	2 3/4
8507	8550	85	5 1/4	5 1/2	2 3/4
8509	8553	85	5	5	2 3/4
8520	.....	85	4 1/4	5 1/2	2 3/4
8521	.....	85	4 1/4	5 1/2	2 3/4
8524	.....	85	5	5 1/2	2 3/4
8530	8531	85	4 1/4	5 1/2	2 3/4
9001	.....	90	5	5	2 3/4
9002	9040	90*	5 1/4	5 1/4	2 3/4
9003	9023	90	5 1/4	5 1/4	2 3/4
9010	9034	90	5	5 1/4	2 3/4
9020	.....	90†	5 1/4	5 1/4	2 3/4
9021	.....	90	5 1/4	5 1/4	2 3/4
9030	.....	90†	4 1/4	5 1/4	2 3/4
9501	9540	95*	5 1/4	5 1/4	2 3/4
10001	10040	100*	5 1/4	5 1/4	2 3/4
10002	.....	100	5 1/4	5 1/4	2 3/4
10003	10022	100	5 1/4	5 1/4	2 3/4
10004	10034	100	5 1/4	5 1/4	2 3/4
10005	.....	100	5 1/4	5 1/4	2 3/4
10020	.....	100	5 1/4	5 1/4	2 3/4
10030	.....	100†	5 1/4	5 1/4	2 3/4
10031	.....	100	5	5 1/4	2 3/4
10035	.....	100	5 1/4	5 1/4	2 3/4
10133	.....	101	5 1/4	5 1/4	2 3/4
11001	11040	110*	6 1/4	6 1/4	2 3/4

Carnegie Steel Company					
Sec. Nos.		Wt. Rail	Base Inches	Height Inches	Tread Inches
Old	New				
60A	6040	60*	4 1/4	4 1/4	2 3/4
60H	6033	60	4 1/4	4 1/4	2 3/4
60K	.....	60	4 1/4	4 1/4	2 3/4
60M	.....	60	4 1/4	4 1/4	2 3/4
60O	.....	60	4 1/4	4 1/4	2 3/4
60P	.....	60	4 1/4	4 1/4	2 3/4
60R	.....	60	4 1/4	4 1/4	2 3/4
60ra	6020	60†	4 1/4	4 1/4	2 3/4
60rb	6030	60†	3 1/2	4 1/4	2 3/4
611N	.....	61 1/2	4 1/4	4 1/4	2 3/4
63H	.....	63	4 1/4	4 1/4	2 3/4
63J	.....	63	4 1/4	4 1/4	2 3/4
65A	6540	65*	4 1/4	4 1/4	2 3/4
65G	.....	65	4 1/4	4 1/4	2 3/4
66B	.....	66	4 1/4	4 1/4	2 3/4
66K	.....	66	4 1/4	4 1/4	2 3/4
67F	.....	67	4 1/4	4 1/4	2 3/4
67H	6733	67	4 1/4	4 1/4	2 3/4
67L	.....	67	4 1/4	4 1/4	2 3/4
68Q	.....	68	4 1/4	4 1/4	2 3/4
68†P	.....	68†	4 1/4	4 1/4	2 3/4
70A	7040	70*	4 1/4	4 1/4	2 3/4
70B	.....	70	4 1/4	4 1/4	2 3/4
70D	.....	70	4 1/4	4 1/4	2 3/4
70H	7033	70	4 1/4	4 1/4	2 3/4
70ra	7020	70†	4 1/4	4 1/4	2 3/4
70rb	7030	70†	4 1/4	4 1/4	2 3/4
71G	.....	71	4 1/4	4 1/4	2 3/4

by hand at least once near the end of the rail, so that it will be near the joints.

*Illinois Steel Company (South Works).*—There may be from one to five figures in the heat number, which is stamped at least twice on the unbranded side of the rail. The rail letter is stamped on by the same machine as is the heat number, and it will, therefore, appear as often as the heat number and following it, as 20967A. The distance between the last figure of the heat number and the letter, may be the means of distinguishing what the proper letter is, as this distance increases regularly for each succeeding letter, for example: 16897 C, and 16897 G.

*Illinois Steel Company (Gary Works).*—There are always five figures in the heat number. In other respects the stamping is identical with that at South Works.

*Lackawanna Steel Company.*—There may be from one to five figures in the heat number, which is stamped at least once on the unbranded side of the rail. The rail letter is stamped on by a separate machine at least twice, generally appearing near the heat number.

*Lorain Steel Company.*—There are always four figures in the heat number, which is stamped by hand near one end of the rail, just so that it will not be covered by the joints. Unless specially provided for, rail letters are not stamped on rails made at this mill.

*Maryland Steel Company.*—Bessemer heat numbers may contain from one to five figures and open hearth heats always contain four figures. These numbers are stamped at least twice on the unbranded side of the rail. They should not be confused with a character, which may show immediately in front of the real heat number. The rail letter immediately follows the last figure of the heat number, being added by the same machine. Typical stamping is 4167D.

*Monterey Iron & Steel Company.*—There are always four figures in the heat number, which is stamped at least three times on the unbranded side of the rail. The rail letter is stamped on by the same machine and immediately follows the last figure of the heat number.

*Pennsylvania Steel Company.*—There are either four or five figures in the heat number, which is stamped on the branded side of the rail at least twice. The branding and stamping may come together and cause some confusion. The rail letter is stamped on by a different machine at least once, generally near the center of the rail.

*Tennessee Coal, Iron & Railroad Company.*—There are always five figures in the heat number, which is stamped on the unbranded side of the rail at least twice. The rail letter is stamped on by the same machine, but appears in front of the heat number, *i. e.*, just opposite to the practice employed at the South Works, of the Illinois Steel Company.

## ABSTRACT OF ENGINEERING ARTICLES SINCE NOVEMBER 21, 1913.

The following articles of special interest to engineers and maintenance of way men, and to which readers of this section may wish to refer, have appeared in the *Railway Age Gazette* since November 21, 1913:

*New Line Over Wasatch Mountains, Utah.*—The D. & R. G. has just completed the building of a 2 per cent. line 15 miles long on the west slope of the Wasatch mountains replacing a line with a maximum grade of 4 per cent. to effect important operating economies. A complete discussion of the operating conditions on the old and new lines, the previous economies that have been made possible by the use of Mallet locomotives and the location and construction of the new line was published in the issue of November 28, page 1013.

An editorial comment on the positions now open to railway engineers on the valuation of railway property that is being undertaken by the government, was published in the issue of December 5, page 1053.

*Summit-Hallstead Cut-off of the D. L. & W.*—The second article on this cut-off, describing the interesting features of the construction of the bridges on the line up to the present time was published in the issue of December 5, page 1069. The article deals largely with the Tunkhannock

viaduct, a reinforced concrete arch structure 2,375 ft. long, which will be the largest bridge of its type in the world.

*Future Development of the Chicago Terminals.*—An abstract of the report presented by Bion J. Arnold to a committee of citizens of Chicago, reviewing the report of John F. Wallace and outlining comprehensive recommendations for a reorganization of the railway terminals in the city, was published in the issue of December 5, page 1078.

*Seams in Rails.*—The general conclusions reached by H. B. McFarland, engineer of tests of the Santa Fe, and M. H. Wickhorst, engineer of tests of the Rail Committee of the American Railway Engineering Association, on the effects of seams in the base of rails as contained in Bulletin No. 160 of that association, were published in the issue of December 5, page 1082.

An editorial comment on the inauguration of an exhaustive study by a joint committee of the American Railway Engineering Association and the American Society of Civil Engineers on the stresses to which a rail in track is subjected was published in the issue of December 12, page 1108.

*Grade Separation Laws and Requirements.*—A full discussion of the state laws and municipal requirements for the elimination of grade crossings of railways and highways including an abstract of 27 state laws and an inset covering the cities in which the largest amounts of this class of work have been done, was published in the issue of December 12, page 1118. An editorial on the same subject was published in this issue, page 1109.

## ECONOMY IN CUTTING RAILS.

By C. L. VAN AUKEN.

For some time past the railways have been trying to instill in employees a spirit of economy in the use of materials and supplies. Our best track men have always been trained along these lines. Doubtless, however, some ideas with regard to the economical use of rails in construction will be of interest to some men who have not had extensive experience in construction.

Some rules are so simple that they are almost axioms, and one of these is: always cut a piece of rail from the shortest available rail from which a piece of the desired length can be obtained; or cut the short piece from a rail with a bad end or an undrilled end. This rule is frequently violated, in spite of its simplicity, and the number of feet of rail scrapped is therefore greater than necessary. The cost of a 100 lb. rail is in the neighborhood of 50 cents per foot, so it is easily seen that some extra attention resulting in the saving of several feet of rail per day may pay the foreman's wages.

Wherever it is necessary to cut a new rail for some purpose where the permissible length of the piece may vary several feet, it is usually advisable to cut the rail in two in the middle, making two 16½ ft. pieces; as the other short rail can then generally be used to advantage. Such a case may occur when locating a switch where the location may be varied several feet without objection.

There are at least five places where, by careful planning, a saving in rail can be effected; (1) where a change is made from square to broken joints on curves; (2) when moving rails to make joints clear a switch rail; (3) where the switch lead necessitates a cut piece about one-half a standard rail length; (4) when putting in a frog, and (5) when putting in a stock rail.

When running into a curve on a track laid with square joints, the rail should be cut as follows: Compute the difference in lengths of the outside and inside rails, then cut a standard length rail into two parts, one shorter than the other by an amount equal to the difference in length of the outer and inner rails. By placing the short piece on the inside rail at the point of curve, and the long piece on the outside of the curve, the joints will be square again at the end of the curve. The difference in length of the inner and outer rails is equal to 1 1/16 in. per degree of curvature for each 100 ft. in the curve.

When moving rails to clear the position to be occupied by a switch rail, a standard length rail should be cut in two at a point such that one piece put in back of the rails in the switch will throw the joints in correct position, and then the opposite

piece will just close up the track at the opposite end of the switch.

When putting in a No. 7 switch, for instance, where a 30 ft. and a 15 ft. rail make a satisfactory length of lead, the two short lead rails, of course, should be cut from 30 ft. rails, thus leaving no waste. In such a case the rail should be cut 14 ft. 10½ in., and 15 ft. 1½ in., the short piece to be used on the straight rail and the long piece on the curved rail. This will square the switch points up nicely.

Wherever possible, a frog should be located so that it, together with the connection rail behind, will be the same length as a standard rail. Then, if the frog is ever taken out, a standard length rail, without cutting, will serve to make the connection.

Stock rails in permanent switches should always be full standard length rails. They wear out faster than ordinary rails, and if they are not of standard length, a rail must be cut each time the stock rail is renewed.

The last two are not cases where a saving is effected during construction, but rather in maintenance. The effect on cost of maintenance and renewal is a feature that should receive more attention.

In the above it has been assumed that a proper method is used in cutting the rail. A poor cut is more damaging than the violation of almost any of the rules mentioned above, as it wastes time and spoils the entire rail, as far as that particular length of rail is concerned.

One of the most essential points in cutting a rail is to have the chisel cuts or marks in the same plane on both sides of the base and web. The chisel cut should be squarely at right angles to the rail, and the chisel should be sharp. No matter how deep a cut is made, difficulty is usually experienced in breaking a rail squarely, which has been cut or rather dented by a dull chisel. The chisel should be struck light square blows with the spike maul, and special caution is necessary when using a new chisel or one with a new edge.

In the oldest method of breaking a rail, the idea prevailed that the depth of cut had considerable effect on the ease of breaking, and the rail was chisel marked all the way around—both sides of the base, both sides of the web, and the top, sides and under portion of the ball. That this idea is erroneous is shown by methods now in use. It was also customary to drop the rail across a "dutchman," or short rail, to break it. This method is not as reliable as others, and, of course, is contrary to "safety first" principles.

A rail may be broken very satisfactorily as follows: Chisel mark both sides of the base and web; place the rail on one side with the ends on blocks; instruct three or four laborers to stand on the rail near the center; place the chisel edge (use a dull chisel) on the web as close to the base as possible, and strike it one or more heavy blows with the spike maul. One blow will be enough in nearly every case. Examine the chisel cut on the part of the flange turned down, and if it is cracked, turn the rail on the opposite side and repeat the process. Then turn the rail workways, have a number of men stand on it, and then have one man jump on it, which nearly always breaks it. If the rail does not break, place the chisel edge *directly* above the chisel cut, and strike it one heavy blow (or more if necessary) with the maul. The face of the ball of the rail, cut in this manner, will present a surface as smooth as that produced by a hack saw.

A second method, for making a quick cut, is to chisel cut the upper side of the flange on one side only. Then turn the rail on its side on the track ties, cut down with the ends on blocks and have three or four laborers with bars press down heavily on the center of the rail, obtaining leverage under the ball of the track rail. Then crack the rail, using the same process as in the first method.

Another method which it is claimed will always break a rail, using only six or seven blows of the hammer, is to lay the rail on its side and cut the edge of the flange with a chisel, striking

three heavy blows. Then turn the rail on the opposite side, with the ends on blocks, and strike one heavy blow. Turn the rail back on the opposite side and strike one heavy blow with hammer. Again turn the rail workways and one blow on ball will break it.

The writer has never seen the last method tried, but has seen the second method used successfully with just two experienced men, handling full length rails, without any assistance whatever. The third method is successful and very rapid, and is therefore especially efficient where a cut has to be made in three to five minutes.

## ANNUAL TRACK INSPECTION ON THE N. Y. C. & H. R.

The report of the annual track inspection of the N. Y. C. & H. R. for 1913 has just been issued. This report shows that subdivision 23 of the Western division, A. M. Clough, supervisor, received the rating of 83.4, the highest of any subdivision on the main line between New York and Buffalo, with subdivision B of the electric division, C. J. Redifer, a close second with a rating of 83.3. The highest rating of an individual section was 85.4, on section 6 of subdivision B of the Electric division, Joe Masulla, foreman. The next highest rating of 84.5 was awarded to section 8, subdivision A, Electric division, Pietro Matzell; to section 7, subdivision 5 of the Mohawk division, Joseph Harris, foreman, and also to section 4, subdivision 12 of the Rochester division, Adelbert Foster, foreman.

No premiums are awarded to supervisors. The foreman receiving the highest rating on each main line subdivision receives a premium of \$3 per month, while the foreman having the best section on each division except on the electric division, receives an additional premium of \$2 per month. In addition, eight foremen having the best section on their respective groups of branch line subdivisions receive a prize of \$2 per month, while 10 yard foremen receive prizes of \$3 per month. As the object of the premium system is to reward foremen for their individual efforts during the year rather than the appearance of their sections on the day of inspection, nine sections receiving high marks were restricted from the premium list because of extra gang work or change of foremen.

## PROVIDING ORDINARY COMFORTS FOR THE SECTION FOREMAN.

BY GEORGE S. CRITES,

Assistant Engineer, Southern Pacific, Benson, Ariz.

Railroads in general concede that the personnel of their track foremen has been deteriorating during the last two decades. The reason oftenest heard for this falling off in the reliability, integrity, and general responsibility of the foremen is the predominating scarcity of labor throughout the industrial field and the poorer mental, moral and physical standards of our immigrants from which the track forces are recruited. It is said with truth, that lucrative employment in agriculture, manufacturing, mining and other industries draw the men from railway track-work, and the railroads are forced to fill up the thinning ranks with the ignorant derelict foreigner.

If the standards of section foremen's positions can be raised the calling will be more esteemed. The management of the Southern Pacific has done much towards this end. They have long stretches of track extending through inhospitable and regions. At intervals are the section headquarters. Neat "adobe" or more recently tile bunk houses are furnished for the laborers, the latter now being standard for the desert country. These have a tendency to keep the laborer contented, as he is well and comfortably housed, and a contented gang has much to do towards keeping the foreman in the same mood.

The standard section foreman's house is complete and up-to-

date in every particular. The same house in a town would rent for from \$18 to \$30 per month, unfurnished, and it usually is by far the best appearing residence in its immediate community. It is a fine thing for the housewife to be able to be proud of her home, and a proud and home respecting wife goes a long way toward putting the same qualities into her husband.

Great pains are taken in planting and keeping suitable shade trees around the section headquarters. The company has plant nurseries at convenient locations, and from these young trees are sent to foremen in order that the grounds around the section headquarters may be made homelike and provide adequate shade. One of the nurseries is the hobby of a roadmaster who has been with the company for 35 years; during 33 of which he has held the position of roadmaster. He has been known to spend an entire day looking through the country for a certain species of tree that he knew would do well in some locality where former tree-planting experiments had not been successful. It is to be remembered that water has to be hauled in tank cars, in some instances many miles, to irrigate the trees in certain locations. In these places a tree would only last a few days without this water. The management is willing to do this for their trackmen's comfort, for a foreman who is willing and wants to have a pleasant appearing headquarters is very apt to take a pride in his work. In passing it might be said that many foremen have complete and useful truck gardens in their yards. Some of these are kept growing with water hauled in tank cars.

Another item that is not overlooked is the pure and wholesome supply of domestic water. This water is hauled from the nearest station, furnishing water not impregnated with salts, in clean steel tank cars set aside especially for this service. At the section quarters it is run into brick or cement cisterns built

### ECONOMICAL BRIDGE ERECTION.

The E. P. & S. W. recently placed two 40-ft. and one 60-ft. deck plate girders across an opening one mile east of Carrizozo, N. Mex., in an economical manner. These girders were riveted up and ties placed on them at the station. They were then swung in between two flat cars and moved to the bridge by a switch engine, the falsework was dropped into the creek bed and the girders were lowered into position. The expense of



Girder Loaded Into Position.

fitting up the two flat cars, as shown in the accompanying photograph, without including ropes and blocks, was \$180, and the labor expense for loading and placing the three girders was \$120, making a total of \$300. The time consumed in placing the 60-ft. girder from the time it arrived at the bridge until it was placed in position and the track restored to traffic was one

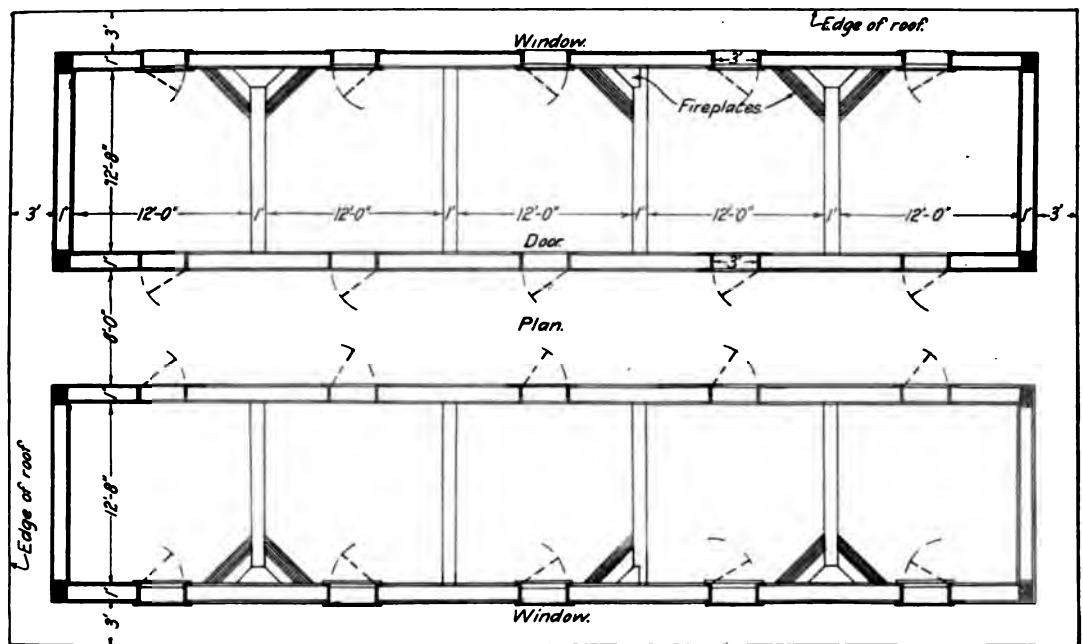
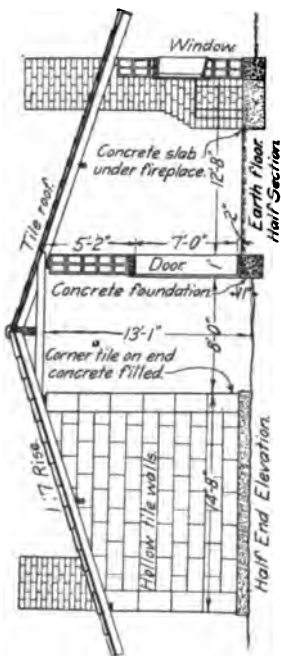

Plan and Elevation of Ten-Room Tile Bunk House for Section Laborers.

underground. In these it keeps fresh and reasonably cool during the hottest summer months. Ice is furnished in the warm localities from early in the summer months until late in the season. Each section gang through these stretches receives between 25 and 50 lbs. of ice daily. This service costs the company in the neighborhood of \$5 per gang per month.

Motor cars are now made standard section equipment and are replacing the old hand cars as fast as the latter wear out, and it has been decided that the motor car will not be used for lengthening out the sections. The time and energy saved by their use is being expended on sections of the old lengths, thus giving a higher standard of maintenance.

hour 40 minutes. The last 40-ft. girder was placed in one hour 20 minutes. The accompanying photograph was taken just after the girders had been lowered to the piers and shows the falsework in the bottom of the gulch as well as the frames on the cars for handling the girders. We are indebted to F. M. Clough, general foreman of bridges and buildings, E. P. & S. W., for the above information.

RAILWAYS OF NEW ZEALAND.—Except for 29 miles of private lines, the railways of New Zealand are in the hands of the government, which now owns and operates 2,860 miles of 3 ft. 6 in. gauge line.



**A TAPER RAIL.**

Instead of the compromise or step joints commonly used between rails of different sections, the Harriman lines have used for a number of years, a taper rail, as shown in the accompanying drawing. This rail is drawn down from one section to another in the space between two ties or about 10 in. to allow an

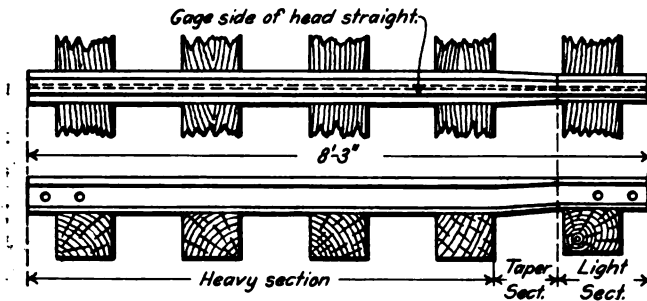

Plan of Taper Rail Used on Harriman Lines.

even bearing on all ties and to permit the use of standard fastenings at the joints. There is also no sudden offset in the width of the head of the rail, as with the compromise joints to catch a wheel flange, but the change in the width of head of the rail is gradual.

**THE FULTON POCKET TARGET.**

The Fulton pocket target is a convenient article for assisting in locating or sighting the line from which a plumb bob is suspended over a given point. It is made of white celluloid and is circular in form with a diamond-shaped opening in the center which offers contrast against the white body of the target so that the plumb line may be more readily seen from an instrument. This target is 2½ in. in diameter, can be conveniently carried in a pocket and can be readily attached and raised or lowered by means of the slots. This target is made by Kolesch & Company, 138 Fulton street, New York.

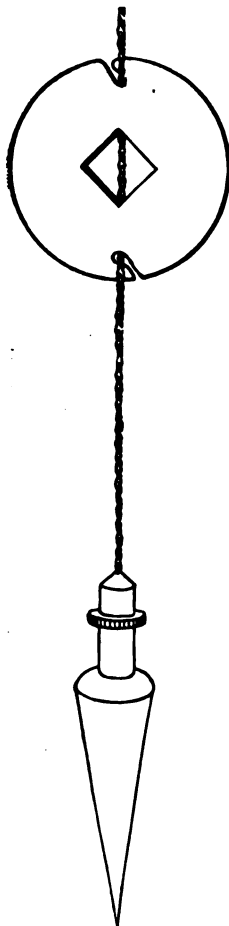

Fulton Pocket Target.

when one knows that all these roads were directly responsible to and under the immediate control of one authority.

**UNIFORM RAILWAY ACCOUNTS IN CHINA.**—The Chinese railway authorities are now engaged in establishing a uniform system of railway accounts. That there is need of this is indicated by the fact that some of the former accounts were but cash books of a most elementary nature, which could hardly be called accounts, from the railway point of view. The accounts of each road not only were different from those of the other roads, but sometimes changed from year to year. Worse still, there appeared to be much useless duplication. Oftentimes one found a complete set of accounts in the Chinese language, rendered in the old fashioned manner, accompanied by another complete set of the same thing in some foreign language—English, German, French or Japanese. This lack of uniformity becomes all the more striking

**THE ABSOLUTE LOCK NUT.**

The Absolute lock nut consists of a slotted recess cut in the inner surface of an ordinary nut and provided with a locking pin which travels in this recess. The recess is beveled so that one end is deep enough to allow the pin to clear the threads of the bolt; the other is shallow enough to force the pin into binding contact with the threads, and the angle is such that the pin is automatically wedged against the threads when the nut is reversed. Any forward motion of the nut throws the pin into the deep end of the recess allowing it to be turned freely, but a reversal throws the pin into the shallow end and immediately locks the nut. The heads of the locking pin are



Absolute Lock Nuts on an Illinois Northern Crossing.

so shaped as to form a continuation of the thread of the nut and when the nut is being turned on the bolt these heads of the locking pin travel in the threads of the bolt.

In applying the nut, it is first screwed onto the bolt about two threads and the pin is inserted when the slot is down. When the heads of the pin are lined up with the threads of the nut the finger is placed inside the nut over the pin to hold the latter in place through a half turn of the nut. In this position the inner head of the pin will be engaged in the thread of the bolt, which obviates the necessity of holding it any longer. The nut can then be tightened to the desired position with a wrench. To remove the nut a nail or brad of convenient size is inserted in the shallow end of the recess, holding the locking

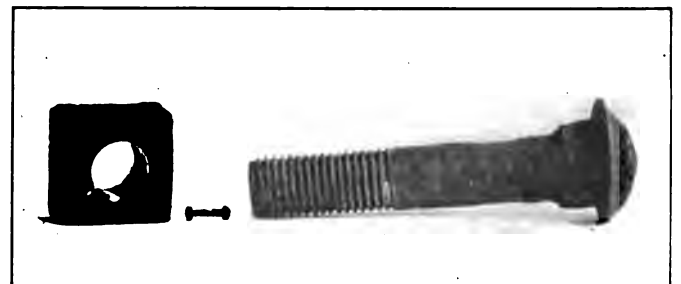

Bolt and Nut Removed from Chicago & Alton Track After Three Years' Service

pin in the deep portion and thus permitting the nut to be turned in the reverse direction.

This lock nut has been in successful use on a large number of roads and for as long periods as three years. The earliest installation, which was made on the Chicago & Alton at Joliet in February, 1910, is still reported to be giving good satisfaction. A photograph of one of the nuts in this installation which was recently removed is reproduced herewith. The American Lock Nut Company, Chicago, owners of the patent and manufacturers of the nut, have until recently operated a small plant in Porter, Ind. The demand for the nuts has so increased, however, that a new factory has been equipped in Pullman, Ill., which has a capacity of 150,000 nuts per day.

**AN ALL-STEEL PASSENGER CAR IN INDIA.**—The South Indian Railway has recently put in service the first all-steel passenger coach built for service in the tropics.

## General News.

It is announced in Washington that beginning January 1 the Postoffice will abandon the practice of sending periodicals by freight trains.

The Baltimore & Ohio has discharged or suspended a large number of employees in its shops and considerable numbers elsewhere.

The Lake Shore & Michigan Southern has laid off 900 men at its Collinwood shops.

The Chicago, Milwaukee & St. Paul has placed the blacksmith and boiler departments of its West Milwaukee shops on a basis of five days a week.

After about six months of negotiations the Chicago & Alton has awarded an increase of pay of one cent an hour to its shop employees at Bloomington, Ill.

The Legislature of New York has passed a law making elaborate provisions for compensation for injuries and deaths of employees engaged in hazardous occupations.

Reductions have been made in the forces in the shops of the Southern Pacific Company in California; the reduction, in most cases, being a very small percentage of the total force.

The state sanitary inspector and pure food commissioner of Idaho has prohibited the use of finger bowls in cafes, hotels and dining cars, as unsanitary. The dining car department of the Northern Pacific discontinued the use of finger bowls over three months ago.

An officer of the Western Pacific reports that along the line of that road from Oroville, Cal., to Gerlach, Nev., 233 miles, three or four thousand unemployed men have camped out nightly during the past month. It is said that large numbers of these men are members of the "Industrial Workers of the World."

Hon. Charles A. Prouty, of the Interstate Commerce Commission, will address the Dartmouth College Alumni Association of Chicago at its annual dinner at the University Club on January 17. He will speak on the work of making a valuation of railway property. Mr. Prouty graduated from Dartmouth in 1875.

At the Pennsylvania station in Philadelphia last Sunday 39 passengers, in the smoking car of a train from the West, were forced by the health authorities to submit to being vaccinated, a passenger having been found in the car who was suffering from virulent smallpox. Two of the passengers resisted the efforts of the health officers for ten hours.

The latest information from Washington is that President Wilson will reappoint Interstate Commerce Commissioner Clements on January 1 and later will appoint a western man in place of the late Commissioner Marble. The president is expected to take no action on Commissioner Prouty's resignation until the freight rate question presented by the Eastern roads has been disposed of.

At Middletown, Conn., December 12, Arthur L. Bradley, the motorman who was responsible for a collision on the New York, New Haven & Hartford, near Middletown, in October, pleaded guilty to the charge of manslaughter and was sentenced to three months' imprisonment in the county jail. Bradley neglected to stop his car at a station where he should have waited for an opposing train.

L. B. Foley, superintendent of telegraph of the Delaware, Lackawanna & Western, is continuing his experiments with the wireless telegraph between the company's stations at Scranton, Pa., and Binghamton, N. Y., and from these places to moving trains. A severe storm of sleet recently disabled the wires between Scranton and Binghamton, and for two hours the dispatcher sent train orders between these two stations by the wireless telegraph.

Eastbound passenger train No. 16 of the Lake Shore & Michigan Southern was derailed on the morning of December 13, about 1 o'clock, at a point near Wickliffe, Ohio, by the malicious loosening of the rails. The fireman was killed and a mail clerk was injured. A. H. Smith, the newly elected president of the

New York Central Lines was in his business car at the rear of the train. The company offered a reward of \$1,000 for the apprehension of the persons guilty of loosening the spikes and splice bars.

In the December 11 issue of *Leslie's* there is an article by Major John McGaw Woodbury describing in a popular and very readable way some things that have been done by the railroads to promote efficiency. The article in question is entirely non-technical, but Major Woodbury, who was chief surgeon on the staff of Major General James H. Wilson during the war with Spain, and chief surgeon under General Miles in Porto Rico, is an expert on efficiency and his comments are, therefore, of interest to railroad men as well as to the general public.

The valuation committee of the National Association of Railway Commissioners, consisting of three commissioners for each of the five groups into which the country has been divided for the valuation of railway property being made by the Interstate Commerce Commission, held a meeting at Chicago on December 10. The committee agreed on plans for keeping in touch with the progress of the work done by the federal commission by attending meetings and conferences to represent the state commissions and to present any information in their possession.

The Louisville & Nashville, through its counsel, has refused to permit the Interstate Commerce Commission examiners to inspect the file in which is the record of the Louisville & Nashville's relations with the Tennessee Central and other Tennessee roads. Chairman Clark, of the commission, has applied to the Senate, which had instructed the commission to make the investigation, for further instructions. Both the commission and the railroad lawyer declare that the question is of importance because it involves a principle which will be used as a precedent in other cases.

Passenger conductors on the Middle division of the Pennsylvania have been instructed to do everything possible to facilitate delivery of telegrams to passengers on trains. If practicable, the telegraph messenger should be allowed to go through the train; and the messenger is to be aided in finding the passenger, as far as this is possible. Where the messenger cannot have time to go into the train the conductor can receipt for the telegram. If a telegram is not delivered the conductor must have a station agent or an operator return it to the telegraph company with proper notation.

H. E. Byram, vice-president, and Hale Holden, assistant to the president, of the Chicago, Burlington & Quincy, testified on December 15 before the board of arbitration that is hearing evidence in the wage controversy between the Burlington and its trainmen and conductors. To controvert statements made by representatives of the employees that the Burlington's traffic and earnings had increased faster than wages Mr. Byram presented tables showing that while freight train miles had increased from 1902 to 1912 only 29 per cent., the freight train wages had increased 58.25 per cent., and while passenger train miles had increased 22.18 per cent., passenger train wages had increased 74.53 per cent.

Arrangements have been made by the real estate and industrial department of the Chicago, Burlington & Quincy to turn over to farmers under lease at a nominal rental lands on the right of way, on each side of the tracks, to be sowed with alfalfa. John B. Lamson, agriculturist of the road, will negotiate leases for all of the right of way space available for this purpose, at the rate of \$5 for each adjacent farm, and it is estimated that approximately 25,000 acres of land will thus be made available for tillage. It is believed that the alfalfa will eliminate much of the danger of fires from locomotives, that it will present a pleasing appearance to passengers and that it will be of financial benefit to the farmers.

The Western Railway Club, Chicago, on Tuesday evening of this week, listened to an interesting paper by Frank McManamy, chief inspector of locomotive boilers for the Interstate Commerce Commission, on the work of his department. He showed records of a marked decrease in accidents from locomotive boiler failures since the Federal inspection law has been in effect. He also mentioned features of boiler construction in which there has been no appreciable improvement since the government began its inspections, and recommended that the railroads take

concerted action to remedy these defects and deficiencies. The speaker exhibited a number of lantern slides showing the results of locomotive boiler explosions.

A bill has been introduced in the lower House of Congress forbidding common carriers to limit below 90 days the time within which claims for loss and damage of freight or overcharges shall be presented. A bill introduced by Representative Stevens, of New Hampshire, designed to give the Interstate Commerce Commission authority over all matters of transportation on interstate railroads in which a question of safety is involved, confers on the commission extensive powers: "the power, after investigation, notice and hearing, to issue an order or orders, fixing, determining and designating changes, improvements and repairs to be made in the way and structures, the kind of equipment, the standard of equipment and supplies, the installation of signal systems, train control devices, automatic train stops and other safety appliances; operating rules, regulations and methods, train schedules, running time of trains, size of train crews, hours of labor for employees. . . ."

The Delaware, Lackawanna & Western has announced to its officers and employees that any suggestion, recommendation or information tending to improve the safety, efficiency or economy of the company's operations, in any direction whatever, when proffered by an officer or an employee, will be submitted to a committee for criticism; and that any device, practice or measure which such committee may approve as useful for the company will be made the subject of an award of money to the one proposing it, the award to bear a fair relation to the money value which the adoption of the improvement shall prove to be to the company. Where an employee offers a device which he desires to have patented, the company will, if the thing be patentable, secure letters patent at its own expense, for the benefit of the inventor, the inventor agreeing that the company may use the invention on its lines free of royalty. President Truesdale, in a circular congratulating officers and employees on the successful and profitable outcome of the past year's activities, gives detail instructions for the proper procedure. Everything offered must be submitted to the Registrar of Contracts, 90 West street, New York City, and from there every proposition will be sent to the committee without the name of the proposer, this to provide for absolute impartiality. The president will designate the officer or committee to investigate the merits of proposals. The sole purpose of this action by the company is to arouse and utilize the interest of every employee in perfecting the Lackawanna into the most highly efficient transportation machine that it can possibly be made.

#### Train Wrecked by Earthquake.

Near Chemnitz, Germany, on the night of December 15 eight persons were killed and 30 or more injured in a passenger train which was crushed, while passing through a tunnel, by the collapse of the roof of the tunnel, which had been disturbed by a slight earthquake. The locomotive and six cars were buried beneath great rocks.

#### Cab Signals on the London & Southwestern.

The Prentice wireless apparatus for cab signals and automatic train stops, which was tried two years ago on the Canadian Pacific, at Toronto, Ontario, is being installed in connection with four block sections, double track, on the London & Southwestern Railway, England.

#### An Appeal to Parents.

This is the title of a "safety-first" pamphlet which has been issued by the Ohio River & Columbus, and it is being circulated among school teachers with a view to having it put into the hands of children, with the hope that they will spread the gospel to their parents. Charles J. Finger, general manager of the road, in a letter to teachers, asking their assistance, reminds them that they already do for their pupils more than the strict letter of duty requires; and on the strength of this he asks them to assume one more burden which perhaps may be unappreciated. The closing chapter of the pamphlet (the whole pamphlet fills only three pages) is in part as follows:

*Mothers, Fathers, Have You Ever Warned Your Children?*  
Have you ever forbidden them to be in the neighborhood of the

trains and station? Have you ever impressed upon them the danger that always lurks near a railroad? If not, will you please do so? Sensible people cannot afford to neglect this as a duty, a duty as great as that of warning them against the misuse of fire arms or any other common danger. Forbid them to be around the tracks or station or yards, except business calls them there. Forbid them under any condition to walk the track or play on railroad bridges. Crossing signs, bells, signals, warnings mean very little to a child. Children do not realize that anything can happen to them. . . .

#### "Safety First" on the Pennsylvania.

Superintendent J. B. Baker of the Philadelphia Terminal division of the Pennsylvania has held recently four "safety first" meetings, at which the aggregate attendance was 3,500. These meetings were held at various points on the division at convenient hours to enable both day and night employees to attend.

G. F. Heidelbaugh, general yard master, acted as chairman and short addresses were made by employees from the various departments. One speaker, Pietro Matteo, crossing watchman, delivered his address in his native tongue, Italian. This address will be printed in English and Italian and will be distributed to employees. Safety Inspectors Carrow and Sheedy also made short addresses with illustrations, showing the practices of today. Motion pictures were also shown. The Italians who listened to Mr. Matteo numbered about 430.

#### Safety First on the Northern Pacific.

Charles T. Banks, special representative of the first vice-president of the Northern Pacific, in charge of the bureau of efficiency, has designed some interesting posters which are being used in the Safety First campaign.

A red card about 5 in. by 7 in. on which is printed in black letters, "THERE'S A SAFE WAY TO DO IT. DO IT THAT WAY. START NOW!" has been posted inside and outside of all buildings and shops where men are employed, in the most conspicuous places, passenger station buildings excepted. Seal clerks, yard clerks and other employees who seal cars and tack destination or switch movement cards on cars were given a supply of these safety cards to attach to each car sealed or carded, the purpose being to flood the Northern Pacific buildings and cars with the cards in the shortest possible time, everywhere and anywhere, so that they would be conspicuous to employees.

Two very large notices are also posted on bulletin boards each month. One with a wide red border headed, "INJURY NOTICE" gives the record for the month as to the number of the various classes of employees injured, and continues,

EIGHTY-SEVEN PER CENT. of these injuries could have been avoided if the injured men had DONE THEIR WORK THE WAY THE NORTHERN PACIFIC RAILWAY CO. HAVE REPEATEDLY ASKED THEM TO DO IT; HAD TAKEN NO CHANCES—HAD DONE THE WORK THE SAFE WAY—THE RIGHT WAY.

CARELESSNESS, HASTE, FAILURE TO THINK OF CONSEQUENCES, DOING THINGS "THE OLD WAY" (BULL-HEADEDNESS) ARE THE THINGS RESPONSIBLE FOR THE LARGE PERCENTAGE OF INJURIES THAT OCCUR.

SUPPOSE YOU JOIN THE "CAREFUL CLUB" FOR SIXTY DAYS AND AVOID GETTING KILLED OR INJURED: THIS WOULD SURE MAKE A HIT WITH THE FOLKS AT HOME.

Another with a black border and headed, "DEATH NOTICE" contains the following:

TWO EMPLOYEES VIRTUALLY COMMITTED SUICIDE DURING THE MONTH OF OCTOBER.

One, a shop laborer, on his way home after work, undertook to crawl under a car—taking with him a sack of flour; switch engine moved the car and killed him. He would have been alive today had he taken the time to walk a short distance around the cars.

The other, a car inspector, finished his inspection of a freight train, took down the blue flag and sat down on the track to light his pipe; the road engine backed onto the train, moved the cars back, caught and killed him.

IS THERE ANY WAY THAT THE NORTHERN PACIFIC RAILWAY CAN PREVENT SUCH TERRIBLE DEATHS?

YOU KNOW THE ANSWER.

WHY DON'T YOU CUT OUT ALL OF THESE "FOOL STUNTS" AND STOP MAKING WIDOWS AND ORPHANS OF YOUR FAMILIES? IT'S UP TO YOU.

### An Unusual Railroad Commissioner.

J. H. Hale, a member of the Connecticut Public Utilities Commission, speaking last week at the meeting of the Massachusetts State Grange in Boston, criticized the forced separation of the New Haven and the Boston & Maine railroads. He said, in part: A great calamity now confronts the leading railroad interests serving this New England agricultural territory. Crushed between professional agitators, financial pirates, labor unions and threatened prosecutions by the government at Washington, these noble truck horses of ours, with greater burdens to carry than ever before, are to be separated in their work, and allowed no extra feed in the way of increased freight rates to make up for the extra strain of an overload of expenses.

"Their side line feeders, the electric railways that pass our farms and are only just beginning to serve us so cheaply and well, are to be cut off. And all for what? Who is to be benefited? Certainly not the stockholders nor train employees; not the traveling public or the receiver or shipper of freight. No one is to be benefited that I can discover, and all are to be injured, except possibly the vultures that pick the remains.

"Probably some of the purchases, mergers and consolidations of the past were technically wrong, too high a price paid for some of them, and those who led in this have paid, or must pay, the penalty. And yet, in spite of all this, the total result was to give all New England better and increased service at no extra cost; and I am clearly of the opinion that a complete separation of all these interests and going back to the old way, as now demanded, will mean turning back the clock of New England's prosperity fully twenty-five years."

### Seth Low on the Railroad Problem.

Seth Low, of New York City, who was one of the board of arbitrators that recently settled the wages of conductors and trainmen, speaking last week at the annual meeting of the National Civic Federation, of which he is president, expressed the opinion that if the government should decline to allow the increase in freight rates now asked for by the Eastern roads a strong impulse would be given to the demand for public ownership and operation of railroads. Investors everywhere, not merely the bankers, are watching the present situation with a concern out of all proportion to the amount of money involved. To compel increases of expenses and forbid increases of earnings will check the flow of capital into American railroads. "I do not say that the Interstate Commerce Commission is at liberty to disregard the economic aspect of the request for higher freight rates, but in my judgment neither is it at liberty to disregard under existing conditions the psychological importance of the decision."

Mr. Low spoke at length on the dangers and difficulties attendant upon government ownership and operation of railroads. He said that in Germany, France, Australia, Italy and Austria the earnings of state owned roads barely equal or fall below the amount paid in taxation by the roads here. He suggested that the railroads lower their passenger rates. "Our railroad managers, if they would think for a moment as government officials, would realize that passengers vote but freight does not. It is true that every person who consumes anything carried by rail pays theoretically a part of the freight, but the percentage in any given case is almost infinitesimally small and the resultant charge for freight borne by a workingman's family is small beyond recognition compared with the addition of even five cents to the cost of his daily journey to and from work."

### The Harriman Safety Medal.

At the dinner of the American Museum of Safety in New York City on Friday evening of last week, the E. H. Harriman medal, provided by Mrs. Harriman as a memorial to her late husband, was awarded to the Southern Pacific Company. Professor F. R. Hutton in the presentation speech stated that the Southern Pacific had had no train accident fatal to a passenger during the past five years. Julius Kruttschnitt, chairman of the board of directors of the company, spoke on behalf of the road, and received a replica of the medal, which is to be made of gold.

The *Scientific American* medal was awarded to the Welin Marine Equipment Company for efficient devices for saving life

at sea. The Rathenau medal was awarded to the General Electric Company for progress in the field of electrical invention, and the Travelers Insurance Company medal to the New York Telephone Company as the American employer who has done the most for the protection of employees in life and limb.

Among the speakers at the dinner was Dr. Arthur T. Hadley, president of Yale University, who said in part:

"My direct knowledge of safety appliances dates from the eighties, when I was an editor of the *Railroad Gazette*. Since those days I have been so occupied with preventing educational derailments and collisions that I have had little time to familiarize myself with the new methods of handling railroad traffic.

"At the International Exposition of Safety and Sanitation I was impressed by the enormous advance made in safety devices and the comparatively small advance made in safety itself. Here, as in many other things, we do not utilize the good appliances of today as well as we did the cruder appliances of thirty years ago. The fault, I think, is not so much with the railroads as with the public officials, and perhaps not so much with the public officials as with the general public, behind those officials. There is an indiscriminate demand for safety which results in too many appliances and too little system.

"What railroads have been constantly urged to do in recent times is to adopt more than one method of preventing accidents; to insure the safety of the passengers if the engineer disobeys his block signal, or to protect the train behind if the brakeman fails to run back and flag it. This sort of alternative provision for safety may do more harm than good. If a new appliance helps to fix responsibility it is a gain; if it tends to weaken responsibility it is a loss. For the truth must never be forgotten that the all-important thing in safety is discipline.

"We hear talk of eliminating the human factor and making safety arrangements which shall be wholly and entirely automatic. The human factor can never be eliminated."

At the exhibition of safety devices which was the occasion of this dinner displays were made by the Pennsylvania, the New York Central, the Southern Pacific, the Baltimore & Ohio and the Chicago & North Western. The Pennsylvania sent men from its shops to give demonstrations of how to revive a man who has been injured by an electric shock. The New York Central showed a reproduction of its "safety first" car which carries the safety-first lecturers of the company to all parts of its territory. The Baltimore & Ohio exhibited models, drawings and other illustrations showing the great variety of safety-first measures which have been put in effect on the lines and at the shops of that company.

### A Statement from Mr. Yoakum.

B. F. Yoakum, chairman of the board of directors of the St. Louis & San Francisco, declaring that the criticisms of his participation in the construction of certain subsidiary lines which were sold to the parent company has been unjust, has sent to the stockholders of the company a statement explaining his doings. The statement goes in detail into the reports which have been published in the newspapers since the hearings at St. Louis, in which the Interstate Commerce Commission inquired into the affairs of the company.

Mr. Yoakum says that it is his ambition to build a new business empire in the Southwest, and that the Frisco system constitutes his life work "and it is my purpose to see it on its feet, with its difficulties cleared away. I intend to see that the stockholders get their money out of the property if they stay with it. The property is worth every dollar against it in both stock and bonds under any fair valuation."

His personal profits, he says, represent only a liberal interest on investments that none but believers in that new and undeveloped territory would have attempted.

"We built the system," he says, "in the only way it could be done at the time.

"Criticism of me is more or less natural, following the receivership, and considering my close connection with the company. My principal motive was not selfish personal gain, but the building of the railroad system and the growth of the country in which it lies. The construction of new railroads through sparsely settled Western sections does not appeal to bankers as investments and therefore syndicate financing in accord with existing custom was employed.

"No one will deny the great changes that have taken place in

public opinion during the past ten years. I recognize the public disapproval of dealings between a corporation and its officials. While I believe it ought not to apply to pioneering enterprises which have in the past depended for their success upon syndicate or individual financing, on the whole I am convinced that the policy is right.

"It is equally true that within the same period many other familiar corporate acts, such as contributions to political campaigns, rebating, trade and traffic agreements, have come under the ban of public opinion."

Mr. Yoakum says that because of the exceeding difficulty of getting money for pioneer railroad building in the sparsely settled Southwest in 1897 it became imperative for him to invest his own funds, forming construction and financing syndicates according to the usual practice of the time. He presents the following table of his profits, the roads mentioned being the only lines he had an interest in:

Road.	My sub- scription.	My profits.	My profit less 6 per cent. interest on investment.
St. Louis & Gulf and St. Louis, Memphis & S. E. . . . .	\$75,000	\$38,187	\$29,187
St. Louis, B. & M. . . . .	300,833	227,580	111,759
St. Louis, San Francisco & New Orleans. . . . .	50,000	7,900	3,900
Oklahoma City & Western. . . . .	22,500	2,933	1,020
Arkansas Valley & Western. . . . .	62,500	11,515	5,283
New Iberia & Northern. . . . .	300,000	None	None
Totals . . . . .	\$810,833	\$288,116	\$151,151

Outside of the above he received \$28,000 in 4½ per cent. bonds from the St. Louis & Gulf Syndicate, and \$37,500 in the sale of the Gulf Construction Company to the Colorado Southern, New Orleans & Pacific.

As to selling securities at less than their par value by a sum in excess of \$30,000,000 the statement says:

"Some of our strongest railroads are now paying as dearly for money as the Frisco ever did. Under the reorganization plan of 1896 the first and second preferred stocks were limited to 4 per cent., and as under the laws of Missouri railroad stock cannot be sold for less than par that plan practically prevented further sale of preferred stock. . . . Grouping the three largest bond issues and taking the net amount of money received, the Frisco paid a total discount, including commissions, of about \$32,000,000. No one received any part of these discounts and commissions except the bankers and investors themselves. . . ."

Mr. Yoakum says that the acquired railroad properties, twelve in number, have all proved profitable to the Frisco, with the possible exception of the Chicago & Eastern Illinois and the New Orleans, Texas & Mexico. "Considered from a broad, constructive standpoint; the larger plans in view and the probable future earnings of these properties, I believe their purchases will be fully justified.

"I confidently believe that the assets of the Frisco will equal the par of all its outstanding bonds, other obligations and stock. The Frisco on account of its superior terminal facilities and other points of advantage, together with its relatively small capitalization, will hold its own with any other railroad in this country. Had it not been for the Mexican revolution since 1910, interchange business with the National Railways of Mexico would have placed the Brownsville line on a paying basis two years ago."

**How Best to Settle Claims.**

1. Courteous treatment of the public.
2. (a) Prompt inspection of damaged freight.  
(b) Prompt tracing of short freight.
3. Issuing promptly and correctly over, short and damage reports.
4. Assisting claimants in making up claims, seeing that they are supported with proper documents when sent in for payment, or before being remitted to auditor for credit after payment.
5. (a) Where inspection shows railroad damages agent should pay claim at once direct to the claimant.  
(b) Where freight is short, claim should be sent to freight claim department, and if goods are short as long as thirty days, claim should be paid at once, investigation made later.
6. Agents and others should not be too technical and should give claimant benefit of any doubtful point.—*Sunset Central Bulletin.*

**Railway Association Secretaries.**

The Society of Railway Associations Secretaries was organized in New York, November 22, by the choice of H. D. Vought, of New York, temporary chairman, and J. E. Fairbanks, of New York, temporary secretary; and a meeting will be held, probably in February, to elect permanent officers. The following ten associations and clubs were represented by the men whose names follow the names of the associations: American Association of General Passenger & Ticket Agents, W. C. Hope; American Electric Railway Manufacturers' Association, H. C. McConaughy; American Railway Association, W. F. Allen and J. E. Fairbanks; American Society for Testing Materials, Prof. E. Marburg; Master Car & Locomotive Painters' Association of the United States and Canada, A. P. Dane; Central Railway Club, Harry D. Vought; Montreal Railroad Club, James Powell; New York Railroad Club, Harry D. Vought; Pittsburgh Railroad Club, J. B. Anderson; Richmond Railroad Club, F. O. Robinson.

Mr. Vought said that he had received letters, largely favorable, from secretaries of fourteen other organizations. A code of rules was tentatively agreed upon and the chairman will appoint a committee to assist in perfecting a permanent organization.

**American Society of Civil Engineers.**

At the meeting of the American Society of Civil Engineers, to be held on December 17, two papers will be presented for discussion, as follows: "Storage to be Provided in Impounding Reservoirs for Municipal Water Supply," by Allen Hazen, M. Am. Soc. C. E., and "The Depreciation of Public Utility Properties as Affecting Their Valuation and Fair Return," by John W. Alvord, M. Am. Soc. C. E.

**MEETINGS AND CONVENTIONS.**

*The following list gives names of secretaries, dates of next or regular meetings, and places of meeting.*

- AIR BRAKE ASSOCIATION.—F. M. Nellis, 53 State St., Boston, Mass. Next convention, May, 1914.
- AMERICAN ASSOCIATION OF DEMURRAGE OFFICERS.—A. G. Thomason, Boston, Mass. Convention, May 19, 1914, St. Louis.
- AMERICAN ASSOCIATION OF GENERAL PASSENGER AND TICKET AGENTS.—W. C. Hope, New York.
- AMERICAN ASSOCIATION OF FREIGHT AGENTS.—R. O. Wells, East St. Louis, Ill. Next convention, April 21, Houston, Tex.
- AMERICAN ASSOCIATION OF RAILROAD SUPERINTENDENTS.—E. H. Harmer, St. Louis, Mo.; 3d Thursday and Friday in May.
- AMERICAN ELECTRIC RAILWAY ASSOCIATION.—E. B. Burritt, 29 W. 39th St., New York. Mid-year conference, New York, January 29, 30, 31.
- AMERICAN ELECTRIC RAILWAY MANUFACTURERS' ASSOC.—H. G. McConaughy, 165 Broadway, New York. Meetings with Am. Elec. Ry. Assoc.
- AMERICAN RAILWAY ASSOCIATION.—W. F. Allen, 75 Church St., New York.
- AMERICAN RAILWAY BRIDGE AND BUILDING ASSOCIATION.—C. A. Litchy, C. & N. W., Chicago. Next convention, October 20-22, 1914, Los Angeles, Cal.
- AMERICAN RAILWAY ENGINEERING ASSOCIATION.—E. H. Fritch, 900 S. Michigan Ave., Chicago. Next convention, March 17-20, Chicago.
- AMERICAN RAILWAY MASTER MECHANICS' ASSOCIATION.—J. W. Taylor, Kopen building, Chicago. June 15-17, Atlantic City, N. J.
- AMERICAN RAILWAY TOOL FOREMEN'S ASSOCIATION.—A. R. Davis, Central of Georgia, Macon, Ga.
- AMERICAN SOCIETY FOR TESTING MATERIALS.—Prof. E. Marburg, University of Pennsylvania, Philadelphia, Pa.
- AMERICAN SOCIETY OF CIVIL ENGINEERS.—C. W. Hunt, 220 West 57th St., New York; 1st and 3d Wed., except June and August, New York.
- AMERICAN SOCIETY OF ENGINEERING CONTRACTORS.—J. R. Weninger, 11 Broadway, New York; 2d Tuesday of each month, New York.
- AMERICAN SOCIETY OF MECHANICAL ENGINEERS.—Calvin W. Rice, 29 W. 39th St., New York.
- AMERICAN WOOD PRESERVERS' ASSOCIATION.—F. J. Angler, B. & O., Baltimore, Md. Next convention, January 20-22, 1914, New Orleans, La.
- ASSOCIATION OF AMERICAN RAILWAY ACCOUNTING OFFICERS.—C. G. Phillips, Highland Park, Ill. Annual meeting, June 24, Minneapolis, Minn.
- ASSOCIATION OF RAILWAY CLAIM AGENTS.—C. W. Egan, B. & O., Baltimore, Md. Next convention, May, 1914, St. Paul, Minn.
- ASSOCIATION OF RAILWAY ELECTRICAL ENGINEERS.—Jos. A. Andreucetti, C. & N. W. Ry., Chicago.
- ASSOCIATION OF RAILWAY TELEGRAPH SUPERINTENDENTS.—P. W. Drew, 112 West Adams St., Chicago. Next convention, May 20-23, New Orleans, La.
- ASSOCIATION OF TRANSPORTATION AND CAR ACCOUNTING OFFICERS.—G. P. Conard, 75 Church St., New York.
- ASSOCIATION OF WATER LINE ACCOUNTING OFFICERS.—W. R. Evans, Chamber of Commerce, Buffalo, N. Y.
- BRIDGE AND BUILDING SUPPLY MEN'S ASSOCIATION.—L. D. Mitchell, Detroit Graphite Co., Detroit, Mich. Meeting with American Railway Bridge and Building Association.

## Traffic News.

**CANADIAN RAILWAY CLUB.**—James Powell, Grand Trunk Ry., Montreal, Que.; 2d Tuesday in month, except June, July and August, Montreal.

**CANADIAN SOCIETY OF CIVIL ENGINEERS.**—Clement H. McLeod, 413 Dorchester St., Montreal, Que.; Thursday, Montreal.

**CAR FOREMEN'S ASSOCIATION OF CHICAGO.**—Aaron Kline, 841 North 50th Court, Chicago; 2d Monday in month, Chicago.

**CENTRAL RAILWAY CLUB.**—H. D. Vought, 95 Liberty St., New York; 2d Thurs. in Jan. and 2d Fri. in March, May, Sept., Nov., Buffalo, N. Y.

**CIVIL ENGINEERS' SOCIETY OF ST. PAUL.**—L. S. Pomeroy, Old State Capitol building, St. Paul, Minn.; 2d Monday, except June, July, August and September, St. Paul.

**ENGINEERS' SOCIETY OF PENNSYLVANIA.**—E. R. Dasher, Box 704, Harrisburg, Pa.; 1st Monday after second Saturday, Harrisburg, Pa.

**ENGINEERS' SOCIETY OF WESTERN PENNSYLVANIA.**—E. K. Hiles, Oliver building, Pittsburgh; 1st and 3d Tuesday, Pittsburgh, Pa.

**FREIGHT CLAIM ASSOCIATION.**—Warren P. Taylor, Richmond, Va. Next convention, May 20-22, Galveston, Tex.

**GENERAL SUPERINTENDENTS' ASSOCIATION OF CHICAGO.**—E. S. Koller, 226 W. Adams St., Chicago; Wed. preceding 3d Thurs., Chicago.

**INTERNATIONAL RAILWAY CONGRESS.**—Executive Committee, 11, rue de Louvain, Brussels, Belgium. Convention, 1915, Berlin.

**INTERNATIONAL RAILWAY FUEL ASSOCIATION.**—C. G. Hall, 922 McCormick building, Chicago. Annual convention, May 18-22, Chicago.

**INTERNATIONAL RAILWAY GENERAL FOREMEN'S ASSOCIATION.**—Wm. Hall, 829 West Broadway, Winona, Minn. Next Convention, July, Chicago.

**INTERNATIONAL RAILROAD MASTER BLACKSMITHS' ASSOCIATION.**—A. L. Woodworth, Lima, Ohio. Next convention, third Tuesday in August.

**MAINTENANCE OF WAY & MASTER PAINTERS' ASSOCIATION OF THE UNITED STATES AND CANADA.**—T. I. Goodwin, C. R. I. & P., Eldon, Mo. Next convention, November 17-19, 1914, Detroit, Mich.

**MASTER BOILER MAKERS' ASSOCIATION.**—Harry D. Vought, 95 Liberty St., New York.

**MASTER CAR BUILDERS' ASSOCIATION.**—J. W. Taylor, Karpen building, Chicago. June 10-12, Atlantic City, N. J.

**MASTER CAR & LOCOMOTIVE PAINTERS' ASSOC. OF U. S. AND CANADA.**—A. P. Dane, B. & M., Reading, Mass.

**NATIONAL RAILWAY APPLIANCE ASSOC.**—Bruce V. Crandall, 537 So. Dearborn St., Chicago. Meetings with Am. Ry. Eng. Assoc.

**NEW ENGLAND RAILROAD CLUB.**—W. E. Cade, Jr., 683 Atlantic Ave., Boston, Mass.; 2d Tuesday in month, except June, July, Aug. and Sept., Boston.

**NEW YORK RAILROAD CLUB.**—H. D. Vought, 95 Liberty St., New York; 3rd Friday in month, except June, July and August, New York.

**NORTHERN RAILROAD CLUB.**—C. L. Kennedy, C. M. & St. P., Duluth, Minn.; 4th Saturday, Duluth.

**PEORIA ASSOCIATION OF RAILROAD OFFICERS.**—M. W. Rotchford, Union Station, Peoria; 2d Thursday.

**RAILROAD CLUB OF KANSAS CITY.**—C. Manlove, 1008 Walnut St., Kansas City, Mo.; 3d Friday in month, Kansas City.

**RAILWAY BUSINESS ASSOCIATION.**—Frank W. Noxon, 30 Church St., New York.

**RAILWAY CLUB OF PITTSBURGH.**—J. B. Anderson, Penna. R. R., Pittsburgh, Pa.; 4th Friday in month, except June, July and August, Pittsburgh.

**RAILWAY ELECTRICAL SUPPLY MANUFACTURERS' ASSOC.**—J. Scribner, 1021 Monadnock Block, Chicago. Meetings with Assoc. Ry. Elec. Engrs.

**RAILWAY FIRE PROTECTION ASSOCIATION.**—C. B. Edwards, Mobile & Ohio, Mobile, Ala.

**RAILWAY GARDENING ASSOCIATION.**—J. S. Butterfield, Lee's Summit, Mo.

**RAILWAY DEVELOPMENT ASSOCIATION.**—W. Nicholson, Kansas City Southern, Kansas City, Mo.

**RAILWAY SIGNAL ASSOCIATION.**—C. C. Rosenberg, Bethlehem, Pa.

**RAILWAY STOREKEEPERS' ASSOCIATION.**—J. P. Murphy, Box C, Collinwood, Ohio.

**RAILWAY SUPPLY MANUFACTURERS' ASSOC.**—J. D. Conway, 2135 Oliver bldg., Pittsburgh, Pa. Meetings with M. M. and M. C. B. Assoc.

**RAILWAY TELE. & TEL. APPLIANCE ASSOC.**—W. E. Harkness, 284 Pearl St., New York. Meetings with Assoc. of Ry. Teleg. Suprs.

**RICHMOND RAILROAD CLUB.**—F. O. Robinson, Richmond, Va.; 2d Monday except June, July and August.

**ROADMASTERS' AND MAINTENANCE OF WAY ASSOCIATION.**—L. C. Ryan, C. & N. W., Sterling, Ill. Next convention, September 8-10, 1914, Chicago.

**ST. LOUIS RAILWAY CLUB.**—B. W. Fraughal, Union Station, St. Louis, Mo.; 2d Friday in month, except June, July and Aug., St. Louis.

**SIGNAL APPLIANCE ASSOCIATION.**—F. W. Edmond, 3868 Park Ave., New York. Meeting with annual convention Railway Signal Association.

**SOCIETY OF RAILWAY FINANCIAL OFFICERS.**—C. Nyquist, La Salle St. Station, Chicago.

**SOUTHERN ASSOCIATION OF CAR SERVICE OFFICERS.**—E. W. Sandwich, A. & W. P. Ry., Montgomery, Ala.

**SOUTHERN & SOUTHWESTERN RAILWAY CLUB.**—A. J. Merrill, Grant bldg., Atlanta, Ga.; 3d Thurs., Jan., March, May, July, Sept., Nov., Atlanta.

**TOLEDO TRANSPORTATION CLUB.**—J. G. Macomber, Woolson Spice Co., Toledo, Ohio; 1st Saturday, Toledo.

**TRACK SUPPLY ASSOCIATION.**—W. C. Kidd, Ramapo Iron Works, Hillsburn, N. Y. Meetings with Roadmasters' and Maintenance of Way Association.

**TRAFFIC CLUB OF CHICAGO.**—W. H. Wharton, La Salle Hotel, Chicago.

**TRAFFIC CLUB OF NEW YORK.**—C. A. Swope, 290 Broadway, New York; last Tuesday in month, except June, July and August, New York.

**TRAFFIC CLUB OF PITTSBURGH.**—D. L. Wells, Erie, Pittsburgh, Pa.; meetings monthly, Pittsburgh.

**TRAFFIC CLUB OF ST. LOUIS.**—A. F. Versen, Mercantile Library building, St. Louis, Mo. Annual meeting in November. Noonday meetings October to May.

**TRAIN DISPATCHERS' ASSOCIATION OF AMERICA.**—J. F. Mackie, 7122 Stewart Ave., Chicago. Next convention, June 16, Jacksonville, Fla.

**TRANSPORTATION CLUB OF BUFFALO.**—J. M. Sells, Buffalo; first Saturday after first Wednesday.

**TRANSPORTATION CLUB OF DETROIT.**—W. R. Hurley, L. S. & M. S., Detroit, Mich.; meetings monthly.

**TRAVELING ENGINEERS' ASSOCIATION.**—W. O. Thompson, N. Y. C. & H. R., East Buffalo, N. Y. Next meeting, Chicago.

**UTAH SOCIETY OF ENGINEERS.**—Fred D. Ulmer, Oregon Short Line, Salt Lake City, Utah; 3rd Friday of each month, except July and August.

**WESTERN CANADA RAILWAY CLUB.**—W. H. Roseyear, P. O. Box 1707, Winnipeg, Man.; 2d Monday, except June, July and August, Winnipeg.

**WESTERN RAILWAY CLUB.**—J. W. Taylor, Karpen building, Chicago; 3d Tuesday of each month, except June, July and August.

**WESTERN SOCIETY OF ENGINEERS.**—J. H. Warder, 1735 Monadnock Block, Chicago; 1st Monday in month, except July and August, Chicago.

At a meeting of the Central Passenger Association last week it was decided to abolish the practice of allowing stop-overs on homeseekers' tickets.

The Merchants & Miners' Line has made a reduction of about 25 per cent. in the rates from Norfolk to Boston and Providence by steamer on potatoes and certain other commodities.

The Central of Georgia and the Atlanta, Birmingham & Atlantic have notified the Georgia State Railroad Commission that they are going to discontinue the sale of interchangeable mileage tickets for intrastate journeys in that state.

The White Audit System of checking passenger train collections has been adopted by the Atlanta, Birmingham & Atlantic, the Fort Dodge, Des Moines & Southern and the Fort Worth & Denver City. The Chicago & North Western, the Chicago, Burlington & Quincy, the Colorado & Southern and the Chicago, Indianapolis & Louisville, have also renewed their arrangements for this service.

The Delaware, Lackawanna & Western has notified employees of the state of New Jersey that in accordance with a recent decision of the State Supreme Court these officers will no longer be carried free on the company's trains. These men are now riding on the railroads of the state without charge by virtue of passes issued to them by the Secretary of State under a law passed a few years ago. The Supreme Court has decided that only members of the legislature and of the court, with a few others, are entitled to free transportation under the law.

The Traffic Bureau of the Merchants' Association of New York City has made a study of the new parcel post rates, which have been announced to go into effect January 1, and finds that as compared with the rates of the express companies now in effect there will be on the great majority of shipments an advantage in sending goods by the parcel post; but after February 1, when the express companies, under the order of the Interstate Commerce Commission, will make a general reduction in their rates, the advantage of the postal rates will be done away with; the rates by express will be the lower.

### Traffic Club of St. Louis.

The sixth annual dinner of the Traffic Club of St. Louis was held on December 2. The following newly elected officers for the ensuing year were installed: President, R. K. Pretty, general agent Great Northern; vice-presidents, Richard Muehlberg, traffic manager Anheuser-Busch Brewing Association; J. L. McNichols, traffic manager Liggett & Myers Tobacco Company; John Fitzgerald, superintendent Louisville & Nashville; O. H. Greene, assistant manager National Lead Company; secretary-treasurer, W. S. Crilly, traffic manager Hargadine-McKittrick Dry Goods Company.

### Changes in Mail Train Schedules.

An improvement in the transcontinental mail service from New York to San Francisco is being made by rearrangements of schedules by the western lines. On December 7, the Atchison, Topeka & Santa Fe changed the schedule of its California Limited train to leave Kansas City at 9:55 a. m., instead of 9:10 a. m.; this in order to wait for the Missouri Pacific train arriving at 9:30 p. m. from St. Louis, where it receives the mail from the Pennsylvania Lines from New York. This would put mail leaving New York at 2:45 a. m. Monday in San Francisco at 10:30 p. m. Thursday. The Chicago, Burlington & Quincy, which has carried the overland mail in connection with the Union and Southern Pacific for 30 years, has a train, No. 7, leaving Chicago at 2:45 a. m., which receives mail from the New York Central Lines and the Pennsylvania Lines. This train's western connection would reach San Francisco at 10:30 a. m. on Friday, or 12 hours later than the Santa Fe. The Burlington has now announced that, effective January 4, train No. 7 will leave Chicago at 2 a. m. instead of 2:45, and arrive at Omaha at 1:15 p. m., a reduction of 50 minutes, while the Union Pacific and Southern Pacific will rearrange their schedules to leave Omaha at 1:30 p. m., instead of 9 a. m., and to arrive at San

Francisco at 2 p. m. on Thursday instead of 10:30 the following morning, 62 hours from Chicago and 86 from New York. The trains from New York to Chicago, Chicago to Omaha, and Omaha to San Francisco are all solid mail and express trains, carrying no passengers. The Burlington also has another train, connecting with the Union and Southern Pacific, which makes approximately the same time but which now will carry only first-class mail west of Omaha. On December 14 the Chicago, Rock Island & Pacific also changed the schedule of its Golden State Limited train to leave Chicago at 8:05 p. m., instead of 9 p. m., arriving at Stn Francisco at 9:15 a. m.

**Car Surpluses and Shortages.**

Arthur Hale, chairman of the committee on relations between railroads of the American Railway Association, in presenting statistical bulletin No. 157, giving a summary of car surpluses

and shortages by groups from August 1, 1912, to December 1, 1913, says:

The total surplus on December 1, 1913, was 67,466 cars; on November 15, 1913, 46,059 cars, and on November 30, 1912, 26,135 cars.

Compared with the preceding period; there is an increase of 21,407 cars, of which 8,602 is in box, 1,426 in flat, 7,101 in coal and gondolas and 4,278 in miscellaneous car surplus. The increase in box car surplus is in groups 1 (New England lines); 3 (Ohio, Indiana, Michigan and western Pennsylvania); 5 (Kentucky, Tennessee, Mississippi, Alabama, Georgia and Florida); 6 (Iowa, Illinois, Wisconsin and Minnesota); 7 (Montana, Wyoming, Nebraska and the Dakotas); 8 (Kansas, Colorado, Oklahoma, Missouri and Arkansas); 10 (Washington, Oregon, Idaho, California, Nevada and Arizona) and 11 (Canadian lines). The increase in flat car surplus is in groups 3, 6, 7 (as above), 9 (Texas, Louisiana and Mexico); 10 and

**CAR SURPLUSES AND SHORTAGES.**

Date	No. of roads.	Surpluses				Total.	Shortages				Total.
		Box.	Flat.	Coal, gondola and hopper.	Other kinds.		Box.	Flat.	Coal, gondola and hopper.	Other kinds.	
Group *1.—December 1, 1913.....	7	155	53	40	298	546	31	6	34	216	287
" 2.—" 1, 1913.....	32	441	48	2,903	183	3,575	132	0	150	0	282
" 3.—" 1, 1913.....	26	2,908	668	1,884	1,296	6,756	101	0	994	450	1,545
" 4.—" 1, 1913.....	12	3,001	345	862	818	5,026	340	271	3,283	30	3,924
" 5.—" 1, 1913.....	22	1,056	100	2,123	771	4,050	1,095	134	576	20	1,825
" 6.—" 1, 1913.....	28	5,873	469	3,450	3,043	12,835	378	4	2	40	424
" 7.—" 1, 1913.....	4	129	50	998	868	2,045	139	2	16	0	157
" 8.—" 1, 1913.....	16	1,474	205	1,920	1,710	5,309	446	42	16	38	542
" 9.—" 1, 1913.....	13	1,367	168	696	1,092	3,323	73	3	8	32	116
" 10.—" 1, 1913.....	22	5,932	1,870	2,745	7,674	18,221	208	15	16	16	255
" 11.—" 1, 1913.....	5	3,855	664	0	1,261	5,780	756	5	0	94	855
<b>Total .....</b>	<b>187</b>	<b>26,191</b>	<b>4,640</b>	<b>17,621</b>	<b>19,014</b>	<b>67,466</b>	<b>3,699</b>	<b>482</b>	<b>5,095</b>	<b>936</b>	<b>10,212</b>

\*Group 1 is composed of New England lines; Group 2—New York, New Jersey, Delaware, Maryland and Eastern Pennsylvania lines; Group 3—Ohio, Indiana, Michigan and Western Pennsylvania lines; Group 4—West Virginia, Virginia, North and South Carolina lines; Group 5—Kentucky, Tennessee, Mississippi, Alabama, Georgia and Florida lines; Group 6—Iowa, Illinois, Wisconsin and Minnesota lines; Group 7—Montana, Wyoming, Nebraska, North Dakota and South Dakota lines; Group 8—Kansas, Colorado, Missouri, Arkansas and Oklahoma lines; Group 9—Texas, Louisiana and New Mexico lines; Group 10—Washington, Oregon, Idaho, California, Nevada and Arizona lines; Group 11—Canadian lines.

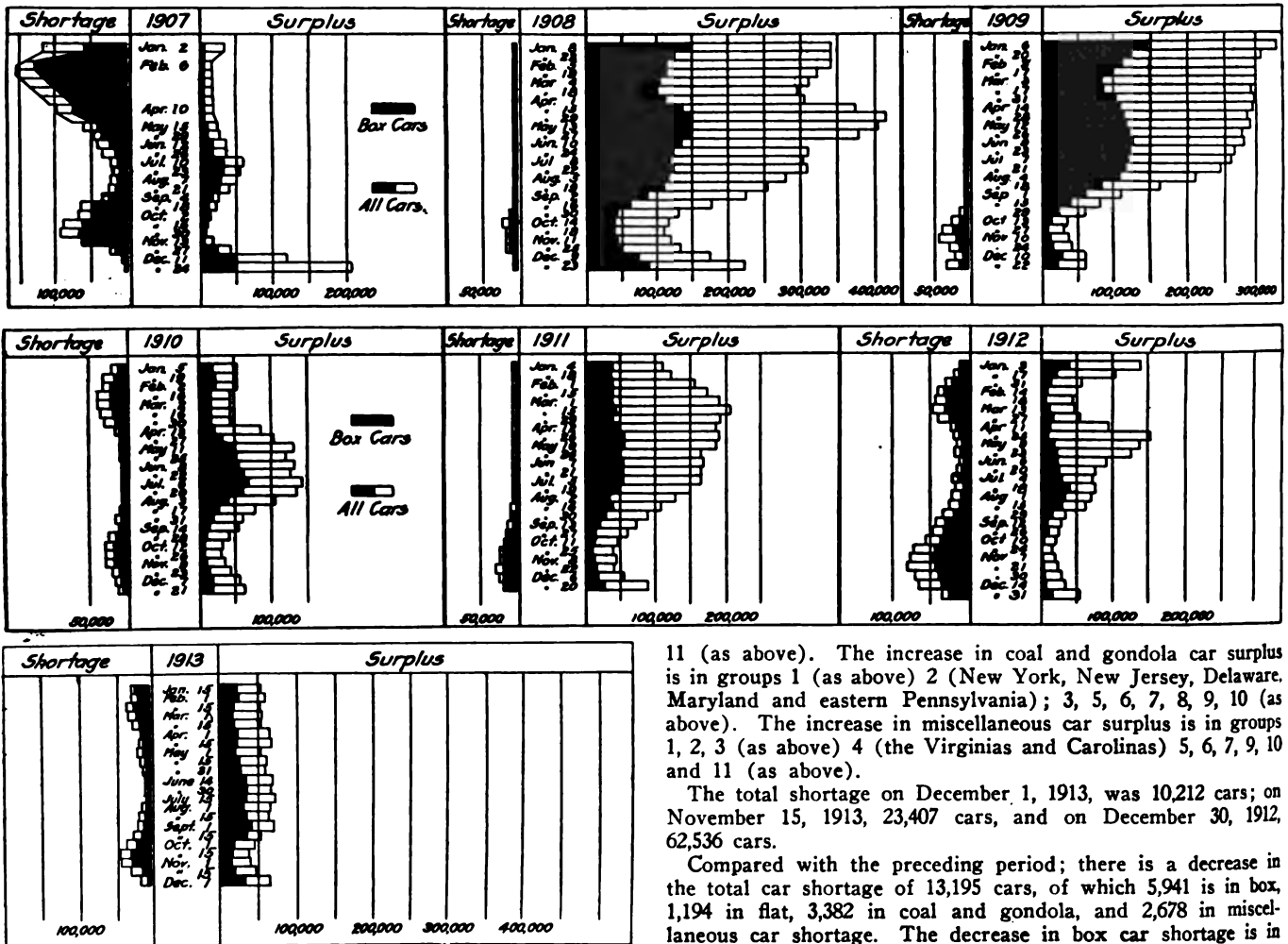

Car Surpluses and Shortages, 1907 to 1913.

11 (as above). The increase in coal and gondola car surplus is in groups 1 (as above) 2 (New York, New Jersey, Delaware, Maryland and eastern Pennsylvania); 3, 5, 6, 7, 8, 9, 10 (as above). The increase in miscellaneous car surplus is in groups 1, 2, 3 (as above) 4 (the Virginias and Carolinas) 5, 6, 7, 9, 10 and 11 (as above).

The total shortage on December 1, 1913, was 10,212 cars; on November 15, 1913, 23,407 cars, and on December 30, 1912, 62,536 cars.

Compared with the preceding period; there is a decrease in the total car shortage of 13,195 cars, of which 5,941 is in box, 1,194 in flat, 3,382 in coal and gondola, and 2,678 in miscellaneous car shortage. The decrease in box car shortage is in all groups, except 7 (as above). The decrease in flat car short-

age is in all groups except 7 and 8 (as above). The decrease in coal and gondola car shortage is in all groups except 1 and 11 (as above). The decrease in miscellaneous car shortage is in all groups except 9 (as above).

Compared with the corresponding period of 1912; there is an increase in the total car surplus of 41,331 cars, of which 20,709 is in box, 1,721 in flat, 10,022 in coal and gondola, and 8,879 in miscellaneous car surplus. There is a decrease in the total car shortage of 52,324 cars, of which 35,024 is in box, 3,900 in flat, 7,683 in coal and gondolas, and 5,717 in miscellaneous car shortage.

The accompanying table gives car surplus and shortage figures by groups for the last period covered in the report, and the diagram shows total bi-weekly surpluses and shortages from 1907 to 1913.

**Car Location.**

The accompanying table, which was taken from bulletin No. 12-A of the American Railway Association, gives a summary of freight car location by groups on November 15, 1913.

CAR LOCATION ON NOVEMBER 15, 1913.

	New England.	N. Y., N. J., Del., Md., Eastern Pa.	Ohio, Mich., Western Pa.	Ind., Va., W. Va., No. & So. Carolina.	Ky., Tenn., Miss., Ala., Ga., Fla.	Iowa, Ill., Wis., Minn.	Mont., Wyo., Neb., Dakotas.	Kans., Colo., Okla., Mo., Ark.	Texas, La., New Mexico.	Oregon, Idaho, Nev., Cal., Ariz.	Canadian Lines.	Grand Total.
Total Cars Owned.....	88,017	691,047	281,236	204,848	174,621	487,892	18,845	154,658	31,975	135,456	145,358	2,413,953
Home Cars on Home Roads.....	39,266	364,143	89,018	99,412	82,335	320,053	6,431	77,116	14,285	72,893	94,004	1,258,956
Home Cars on Foreign Roads.....	48,751	326,904	192,218	105,436	92,286	167,839	12,414	77,542	17,690	62,563	51,354	1,154,997
Foreign Cars on Home Roads.....	58,196	300,960	212,204	87,943	82,138	194,710	11,898	80,372	34,103	59,174	43,807	1,165,505
Total Cars on Line.....	97,462	665,103	301,222	187,355	164,473	514,763	18,329	157,488	48,388	132,067	137,811	2,424,461
Excess or Deficiency.....	9,445	*25,944	19,986	*17,493	*10,148	26,871	*516	2,830	16,413	*3,389	*7,547	10,508
Surplus.....	363	5,410	958	5,866	903	8,045	717	4,531	3,229	13,588	2,449	46,059
Shortage.....	645	1,838	4,540	6,542	3,323	1,052	153	1,471	359	1,333	2,151	23,407
Shop Cars—												
Home Cars in Home Shops.....	5,098	33,609	19,459	13,066	11,540	26,136	504	9,796	2,251	4,480	6,406	132,345
Foreign Cars in Home Shops....	1,126	7,674	6,578	1,815	2,021	5,416	491	2,508	1,140	2,130	266	31,165
Total Cars in Shops.....	6,224	41,283	26,037	14,881	13,561	31,552	995	12,304	3,391	6,610	6,672	163,510
Per Cent. to Total Cars Owned—												
Home Cars on Home Roads.....	44.61	52.69	31.65	48.53	47.15	65.60	34.13	49.86	44.68	53.81	64.67	52.15
Total Cars on Line.....	108.45	96.25	107.03	91.46	94.19	105.51	97.26	100.14	151.33	97.50	94.81	100.44
Home Cars in Home Shops.....	5.79	4.86	6.92	6.38	6.61	5.39	2.68	6.33	7.04	3.31	4.41	5.48
Foreign Cars in Home Shops.....	1.02	1.11	2.34	.88	1.16	1.12	2.60	1.51	3.57	1.57	.18	1.29
Total Cars in Shops.....	6.81	5.97	9.26	7.26	7.77	6.51	5.28	7.84	10.61	4.88	4.59	6.77

\*Denotes deficiency.

**Joint Report on B. & M. Freight Rates.**

The Massachusetts Public Service Commission made public at Boston this week the report of the conference of the Interstate Commerce Commission and the commissions of the New England states on the Boston & Maine's proposition to increase freight rates. This report has no authoritative character, but the rates approved in it are expected soon to be embodied in orders to be issued by the several commissions. Following are the salient features of the report:

"We are clearly of the opinion that there should be a substantial advance now, provided that such additional revenue can be obtained without imposing upon the public unreasonable charges, and provided further that some assurance can be given that the money will be prudently expended in the public interest.

"We do not assent to claims of counsel for the company that such increase should amount to at least \$5,000,000 a year. It cannot be known until the property is once more efficiently and properly operated and until its leasehold lines have been valued, how much the advance should be.

"The Boston & Maine, on the basis of its present rates, is bankrupt. From an analysis of its operating expenses it seems probable that its income from operation will fall at least \$1,000,000 short of what it was in the preceding fiscal year.

"Certain charges against income will be materially increased during the current year. Owing to an advance in the rate of interest, the interest charges will be increased approximately \$600,000. Owing to an increase in the per diem charge for the use of freight cars, the item for hire of equipment, if the same amount of business is transacted, and if no greater car efficiency can be secured, will be approximately \$400,000 larger. It now appears probable that for the year 1914 the road will lack, if no increase in rates is allowed, \$2,000,000 of sufficient income to pay its taxes, its interest, and its fixed charges, without the payment of any dividend upon its capital stock.

"This deplorable showing is in part due to mismanagement. The Boston & Maine has outstanding \$27,000,000 of short-time paper, which it will carry for the current year at a charge of about 7½ per cent., as compared with 5¼ per cent. for the preceding year. Of this short-time paper \$20,000,000 was used to purchase stocks which the Boston & Maine now owns. Assuming that these stocks may finally be worth the price paid, which is doubtful, their purchase at the time was utterly unnecessary and ill-advised, and the consequences of those transactions ought not to be visited upon the rate-paying public.

"The attempt of the New York, New Haven & Hartford to acquire a control of the Boston & Maine and combine that system in operation with its own proved disastrous, and the effect is still obvious in the operating cost of the Boston & Maine.

"We have divided the Boston & Maine into two classes. Class A embraces the following: Main lines between Boston and Portland, main line between Boston and Concord, N. H.; entire main line of the Fitchburg; Cheshire and Troy branches of the Fitchburg, main line between Springfield, Mass., and Windsor, Vt.; main line from Worcester to Nashua, Stony Brook branch, Saugus branch, Lexington branch, Watertown branch and Med-

ford branch. Class B includes all other lines of the system.

"We have approved the railroad maximum for Class A lines. We think that a schedule 16¾ per cent. higher should be applied on Class B lines, and that between points on Class A and Class B lines a constructive mileage should be made up by adding together the actual mileage on the Class A line and the actual mileage on the Class B line, plus 25 per cent. of Class B distance, and that to this constructive mileage the Class A scale should be applied.

"The scales thus approved differ radically from that first presented by the railroad. While some increase in revenue will result to the carrier our central thought has been to provide a system of local class rates which would remove the glaring discriminations between individuals and localities which now exist and pave the way for a proper revision of the commodity rates of that company.

"An advance in mileage book rates is urged. A radical change in the directorate is recommended, and Morris McDonald is declared to be unable adequately to supervise two roads; he should give all his time and energy to the Boston & Maine and none to the Maine Central. . . . The traffic departments of the Boston & Maine and the New Haven should finally be entirely separated.

"The present financial condition of the Boston & Maine is critical. Nobody can tell exactly what should be done to protect the just interests of all concerned. It may finally turn out that these properties should be thrown into the hands of a receiver, and pass through a process of reorganization, but this would be a calamity which ought to be avoided if possible. The present condition was years in forming, and will require years in the correction. If disaster is to be avoided, all interested parties must exercise forbearance and must undergo temporary inconvenience.

"The stockholders of the Boston & Maine cannot reasonably



expect to receive further dividends in the immediate future. The financiers who are carrying the short-time paper might well abate something from their present demands. The owners of the leased properties might well accept something less than the full rent reserved for the next two or three years. The public must expect to sustain some part of the burden. It should not be taxed for the mismanagement of this property, but it should remember that the cost of furnishing the service now demanded has increased, and that this property is entitled to a fair return."

**An English View.**

Sir George Paish, of London, editor of the *Statist*, now in America, says that he is convinced that freight rates on the railroads of the United States should be higher. "The rail road president who sees his expenditures increasing by leaps and bounds and his income decreasing may be pardoned for advocating better rates. . . . The American railroads by their lack of confidence in the future, and their uncertainty with regard to labor conditions and net income, have promoted business depression. They have cut down their orders for steel rails, thereby causing steel mills to curtail their operations.

"British investors are heavily interested in American railways and we do not want another period like that in the nineties, when many railroads defaulted on their interest.

"On the whole, I have no apprehensions as to the future. As far as I am able to judge, the people of the United States may rest assured that there will be no panic. The business depression is general throughout the world, being felt in South America as well as in Europe. It is by no means most acute in the United States."

**Car Balance and Performance.**

Arthur Hale, chairman of the committee on relations between railroads, of the American Railway Association, in presenting statistical bulletin No. 158, covering car balances and performances for August, says:

The committee presents herewith statistical bulletin No. 158, covering car balance and performance for August, 1913.

The miles per car per day were 25.2, compared with 23.7 in July. This figure for August, 1912, was 24.3.

Ton miles per car per day for August were 382, compared with 375 in July. This is a decrease of .78 per cent. compared

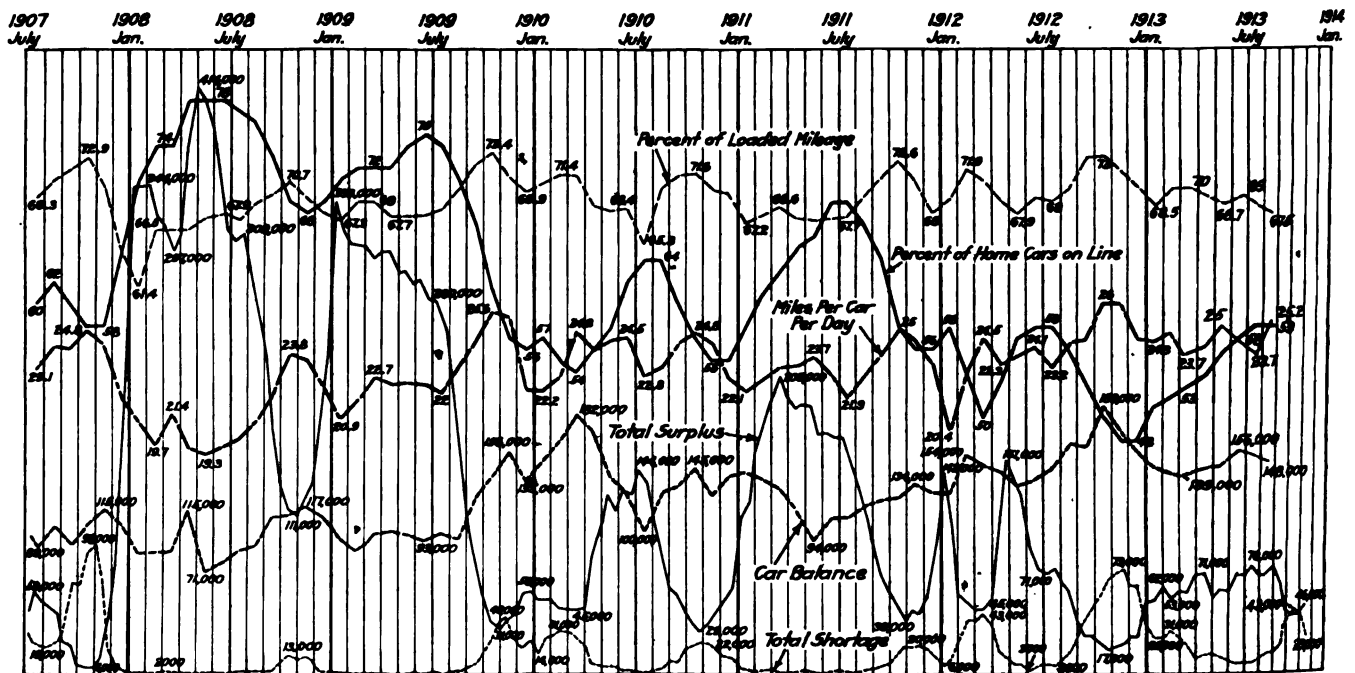
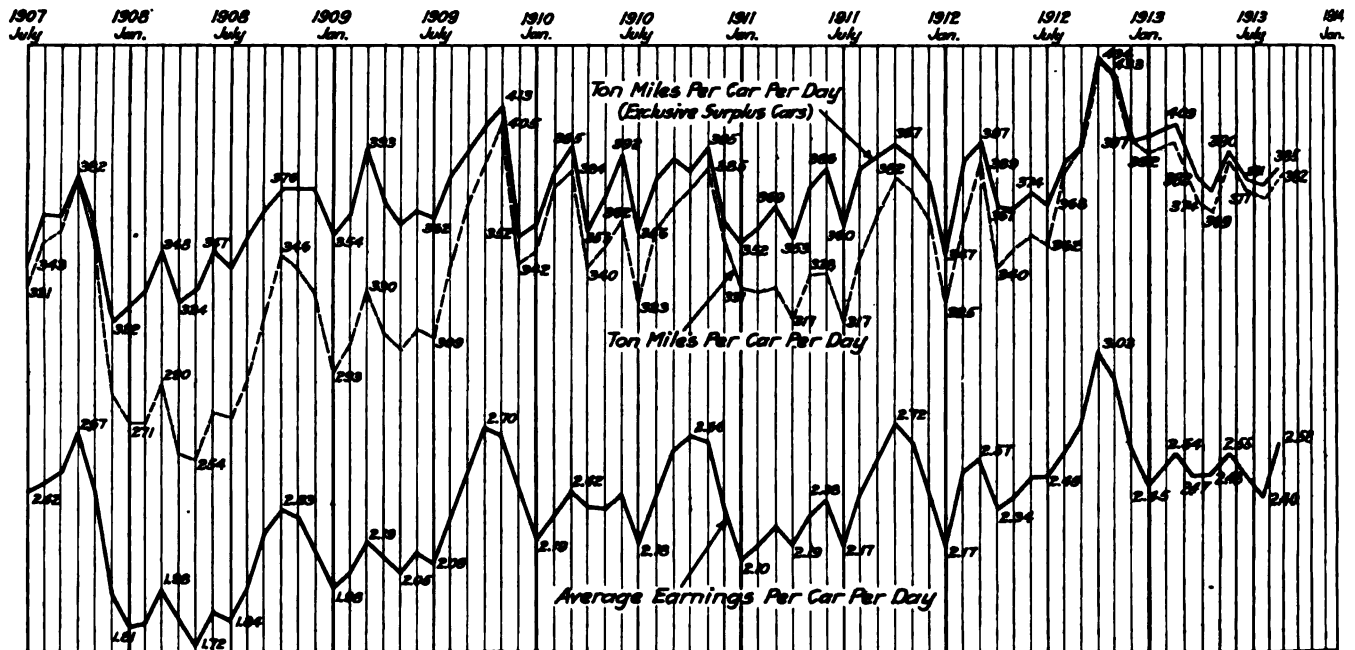

Freight Car Mileage, Earnings and Performance, 1907 to 1913.

CAR BALANCE AND PERFORMANCE IN AUGUST, 1913.

	New England.	N. Y., N. J., Del., Md., Eastern Pa.	Ohio, Ind., Mich., Western Pa.	Va., W. Va., No. and So. Carolina.	Ky., Tenn., Miss., Ala., Ga., Fla.	Iowa, Ill., Wis., Minn.	Mont., Wyo., Neb., Dakotas.	Kan., Colo., Okla., Mo., Ark.	Texas, La., New Mex.	Ore., Idaho, Nev., Cal., Ariz.	Canadian Lines.	Grand Total.
Revenue freight cars owned.....	90,099	704,791	203,061	188,787	173,146	443,133	18,347	146,179	27,916	138,054	164,663	2,298,176
Average number of system cars on line.....	46,153	395,822	122,275	100,493	87,623	317,941	5,611	75,091	17,960	74,662	117,589	1,361,220
Revenue freight cars: Average foreign on line....	46,766	296,133	106,650	65,404	64,695	155,986	8,561	67,460	21,139	41,881	37,728	912,403
Total Railway-owned cars on line.....	92,919	691,955	228,925	165,897	152,318	473,927	14,172	142,551	39,099	116,543	155,317	2,273,623
Excess.....	2,820	-12,836	23,864	-22,890	\$20,828	30,794	-4,175	-3,628	11,183	-21,511	-9,346	-24,353
Per cent. of cars on line to total owned:	51	56	60	53	51	72	30	42	64	48	71	59
Home.....	52	42	53	37	37	35	47	47	76	29	23	40
Foreign.....	103	98	113	88	88	107	77	93	140	77	94	99
All railways.....	3,705	35,432	10,135	3,602	10,075	17,052	2,543	9,819	2,965	11,474	7,015	113,817
Total, all cars on line.....	96,624	727,387	239,060	169,499	162,393	490,979	16,715	152,370	42,064	128,017	162,332	2,387,440
No. of freight engines owned.....	7,98	6,37	11,41	8,53	9,77	5,76	8,52	8,89	8,37	6,52	4,40	7,35
Average cars on line per freight engine owned....	1,443	10,446	3,021	3,518	2,955	7,288	510	2,943	846	2,861	2,605	38,426
Total freight-car mileage.....	56,624,281	628,280,899	157,879,485	135,983,042	133,751,152	350,575,331	28,659,705	105,024,157	31,855,572	119,805,452	108,391,591	1,856,830,667
Average mileage per car per day.....	18.0	28.0	21.2	25.9	26.6	23.0	55.3	23.3	24.4	20.1	21.5	25.2
Per cent. loaded mileage.....	76.0	58.7	80.5	67.3	70.6	70.0	71.3	69.5	71.3	72.2	74.5	67.5
Ton-miles of freight, including company freight....	665,846,875	9,007,929,722	2,804,661,992	2,311,178,903	1,933,094,940	4,623,395,312	439,199,955	1,514,368,356	463,041,526	1,794,556,462	1,811,418,378	27,368,692,421
Average ton-miles, including company freight:												
Per car-mile.....	11.8	14.5	18.4	17.0	14.5	14.8	15.3	14.4	14.5	15.2	16.7	15.2
Per loaded car-mile.....	16.3	24.7	32.9	25.3	20.6	20.9	20.6	20.7	20.4	21.1	21.1	22.5
Per car per day.....	222	404	390	440	386	339	848	336	355	458	360	382
Gross freight earnings.....	\$7,134,953	\$51,957,251	\$15,389,024	\$12,271,877	\$12,240,131	\$36,211,240	\$3,258,971	\$19,631,393	\$3,830,841	\$17,485,903	\$10,846,912	\$190,258,496
Average daily earnings: Per car owned.....	\$2.55	\$2.40	\$2.44	\$2.10	\$2.28	\$2.64	\$5.73	\$4.33	\$4.43	\$2.12	\$2.12	\$2.65
Per railroad car on line.....	2.48	2.46	2.17	2.39	2.59	2.46	7.42	4.65	3.16	4.72	2.25	2.70
All cars on line.....	2.38	2.33	2.08	2.34	2.43	2.38	6.29	4.36	2.94	2.16	2.16	2.58

\*Denotes deficiency.

with the figure for August, 1912, which gives a total of 385. The proportion of home cars on line was 59 per cent., which is the same as July, 1913. This is an increase of three points over August, 1912.

The per cent. of loaded car mileage decreased from 68.1 per cent. in July to 67.5 per cent. in August, 1913. This figure for August, 1912, was 70.1 per cent.

The average earnings per car per day for all cars on line increased 18 cents to \$2.58 in August, 1913. This figure for August, 1912, was \$2.60.

The accompanying table gives car balance and performance in the month covered by the report, and the diagram shows car earnings and car mileage and different car performance figures monthly from July, 1907.

State Commissioners Favor Uniformity of Express Rates.

Members of the express committee of the National Association of Railway Commissioners, consisting of a member of each state railway commission, held a meeting at the Hotel La Salle, Chicago, on December 11 and 12 to consider the effect of the Interstate Commerce Commission's system of express rates, ordered effective February 1, on the intrastate rates. The meeting was presided over by Chairman Martin S. Decker, of the New York second district commission. W. A. Ryan, representing the Interstate Commerce Commission, outlined the basic principles of the commission's system of making rates by blocks, and T. B. Harrison, attorney for the American and Adams express companies, addressed the meeting on the effect of the rates on the companies. He said that the new rates would reduce the revenues of the five principal companies by from \$15,000,000 to \$20,000,000 per year in addition to the reduction in their business caused by the parcel post competition. They can only make up for these reductions by increased efficiency, which would be facilitated by uniformity in the state rates. In 15 states the application of the commission's rates would increase the revenue, while in other states the rates would be reduced by from 1.18 to 19.24 per cent. The commission's reductions had been chiefly on the packages less than 50 pounds, and if the states would permit them to charge the 100-pound rates fixed by the commission the companies were hopeful that they could work out their salvation.

There was considerable opposition to an approval of the Interstate Commerce Commission's rates among the commissioners of states whose rates would be increased by their application, but the meeting finally went on record as favoring uniformity of rates on the block system prescribed by the federal commission, with a provision for retaining advantages in state rates by making "sub-block" rates subject to local conditions. A sub-committee of ten members was appointed to work out a plan of adopting the sub-block system to the commission's plan and rates.

INTERSTATE COMMERCE COMMISSION.

The commission has further suspended from December 20 to June 20, a tariff of the Oregon Short Line, which proposed to eliminate certain routes applying on shipments of green fruit in carloads from stations on the Oregon Short Line to eastern destinations.

The commission has further suspended from December 30 to June 30, schedules in a tariff of W. H. Hosmer, agent, which provided for substantial increases in rates on box board in carloads from Wilmington, Ill., to Milwaukee, Wis., and between certain other points.

The commission has further suspended from December 20 to June 20, tariffs of the St. Louis Southwestern which proposed to increase rates on lumber and other forest products from stations on the St. Louis Southwestern to points in Iowa, Minnesota, Missouri, South Dakota, Illinois and Wisconsin.

Discrimination in Car Distribution.

The Huerfano Coal Company, et al., v. Colorado & South-eastern, et al. Opinion by Commissioner Marble:

This case arises because of the dissatisfaction with the methods

of car distribution practised by the defendants. The Colorado & Southeastern, an adjunct of the Victor-American Fuel Company, and a common carrier has trackage rights over the Colorado & Southern to Trinidad, a point upon the Atchison, Topeka & Santa Fe, under a contract which stipulates that the Southeastern shall not engage in business at any point upon the Colorado & Southern. It has been held that mines upon the Colorado & Southern have no claim upon the Colorado & Southeastern for cars or service. That road, having no cars, the duty of supplying them to shippers on its lines is undertaken by the Colorado & Southern and the Denver & Rio Grande jointly. In addition the Southeastern, by reason of the trackage rights to Trinidad, is able to secure coal cars from the Santa Fe. It thus happens, that the Victor-American Fuel Company is at all times well supplied with Santa Fe cars, whereas, shippers on the other two lines have no claim to them. The commission finds that this arrangement is discriminatory and says that each carrier shall be charged with the duty of furnishing cars for the transportation conducted over its line. The carrier's obligation to furnish cars to points upon the lines of its connections is joint with the latter, and contracts with them cannot relieve it of its portion of such joint liability.

#### Government Loses in Oregon Short Line Through Route Case.

*The United States of America v. Union Pacific et al. Opinion by Commissioner Clark:*

The United States, in a complaint apparently not ordered by any executive officer or lawfully empowered department of the government, alleges that the failure and refusal of the defendants to establish through routes and joint rates between Chicago and other points and Oregon Short Line stations via the Northern Pacific and the Atchison, Topeka & Santa Fe, subjects these carriers to undue prejudice, and disadvantage, deprives the government of the full benefit of land-grant deductions reserved to it by statute, and defeats the spirit and purpose of the so-called public highways act. The commission finds that these allegations of undue disadvantage are not sustained, and holds that existing through routes via the Union Pacific are not shown to be unreasonably long, inadequate or unsatisfactory. The Union Pacific and Oregon Short Line are operated jointly and under a common management or control, and no facts are shown which overcome the clear intent of section 15 of the act. The commission is not empowered to require carriers to grant to the United States free transportation or other rates or concessions than those afforded the general public, and is not deprived of jurisdiction to consider the merits of the controversy by absence of affirmative showing of the right of the officers presenting the complaint to do so in the name of the United States. (28 I. C. C., 518.)

#### STATE COMMISSIONS.

The Louisiana railroad commission has denied a petition of several railways for approval of the national code of uniform demurrage rules and regulations of the American Railway Association.

The Railroad Commission of Mississippi has ordered a reduction in the rates for the transportation of syrup, to go into effect January 1. The makers of syrup have a large crop and they say that they are unable to reach the markets on account of the high freight rates.

The Illinois Railroad and Warehouse Commission has ordered the Chicago & Alton to run two of its Chicago-St. Louis passenger trains via East St. Louis and the Eads bridge, instead of over the Merchants' bridge. By the last named route the trains avoid East St. Louis.

The Louisiana railroad commission has approved a petition of the railways of the state for authority to withdraw from sale mileage books and to substitute a penny script book to be sold at \$25 and to include \$30 in coupons, of one cent each, interchangeable on all lines in the state, to be accepted on trains or in exchange for tickets at stations. This is accepted in lieu of the proposal of the commission to fix the local passenger rate at 2½ cents per mile.

## Railway Officers.

### Executive, Financial and Legal Officers.

The statement in our issue of December 5, page 1096, that Oscar Lawler had been elected auditor of the San Pedro, Los Angeles & Salt Lake, with office at Los Angeles, Cal., was in error. Mr. Lawler has been elected a director of the company succeeding H. I. Bettis, deceased, but the appointment of an auditor has not been made.

Edward M. Hyzer, for the past four years general counsel of the Chicago & North Western at Chicago, has been appointed



E. M. Hyzer.

vice-president and general counsel, in charge of the law department of that road and the Chicago, St. Paul, Minneapolis & Omaha, with office at Chicago. Mr. Hyzer was born December 10, 1854, at Janesville, Wis. After receiving a public school education he studied law under Judge John B. Cassoday of the Wisconsin Supreme Court, and was admitted to the bar in 1879. From 1899 to April, 1909, he was Wisconsin attorney for the Chicago & North Western, from which position he was promoted to the office of general counsel at Chicago. For about six

years previous to 1909 Mr. Hyzer was a member of the law firm of Cary, Upham & Black of Milwaukee, Wis.

### Operating Officers.

A. G. Whittington, superintendent of the San Antonio division of the International & Great Northern, has been appointed acting general manager, with office at San Antonio, Tex., succeeding Henry Martin, deceased.

J. F. Alsip, chief despatcher, has been appointed trainmaster of the Tacoma division of the Northern Pacific, at Tacoma, Wash., and J. F. Coleman has been appointed chief despatcher to succeed him.

The following have been appointed assistant superintendents of the St. Louis & San Francisco, with supervision over station work: J. J. Cummins, Northern division; C. H. Hensley, Ozark division; C. F. Kirchner, Southeastern division; C. M. Clark, Eastern division; E. E. Carter, Kansas division; C. A. Irvin, Red River division; C. O. Claiborne, Western division; R. H. Phinney, Central division.

J. C. Stuart, vice-president of the Erie, in charge of operation, has resigned, on account of continued ill health. Mr. Stuart is now on leave of absence, and on resuming duty will become assistant to the president, with office at New York. Mr. Stuart's retirement from the vice-presidency is followed by a number of changes in the operating department, all to take effect January 1. Three grand operating divisions will be established instead of two, the Ohio grand division (the lines west of Salamanca) being divided and the western part being made into the Chicago Terminal grand division. Albert J. Stone, general manager of the Eastern grand division, with office at New York, continues general manager of that division, and will be the ranking general manager. While Mr. Stone's title will be the same as at present, he succeeds to the duties of Vice-President Stuart, with authority throughout the Erie lines. Heads of departments heretofore reporting to the vice-president in charge of operation will now report to the general manager at New York. R. S. Parsons, now assistant general manager of the Erie (Eastern) grand division, will become general manager of the Ohio division, with office at

Cleveland, Ohio. J. B. Dickson, now superintendent of the New York division, is appointed assistant general manager of the Ohio grand division, with office at Cleveland. H. O. Dunkle, general manager of the Ohio division, becomes general manager of the Chicago division and the Lake Lines, with office at Chicago. F. B. Lincoln, now assistant to the receiver of the Pittsburgh, Shawmut & Northern, is appointed general superintendent of the Erie grand division, with office at New York City. W. A. Baldwin, superintendent of the Delaware division, becomes assistant general superintendent of the Erie grand division, with office at New York City. E. W. Batchelder, now assistant general manager of the Ohio division, is appointed general agent at Jamestown, N. Y. C. P. Eckels, superintendent of the Wyoming division, is made superintendent of the Delaware division, with office at Susquehanna, Pa. J. J. Mantell, now terminal trainmaster at Jersey City, is appointed superintendent of the Wyoming division, with office at Dunmore, Pa. E. R. Allen, general agent at Jamestown, is appointed assistant superintendent of terminals at Jersey City, N. J. A. B. Shafer, assistant superintendent of the New York, Susquehanna & Western, and the Wilkes-Barre & Eastern, is appointed superintendent of those roads, with office at Jersey City, N. J. M. E. Johns, now superintendent of the two roads last named, becomes superintendent of terminals of the New York Susquehanna & Western, with office at Jersey City, N. J.

#### Traffic Officers.

M. F. Smith has been appointed general agent of the Kansas City Southern at Los Angeles, Cal.

W. H. Guerin, general agent, passenger department of the Chicago & North Western at Detroit, Mich., has been retired on a pension.

P. B. Norton has been appointed agent passenger department of the Union Pacific at Fresno, Cal., and S. F. Hilton, agent freight department.

F. M. Williams has been appointed division freight agent of the Atchison, Topeka & Santa Fe, with headquarters at Trinidad, Col., succeeding W. P. Matchette, assigned to other duties.

A. G. Sheer, chief of the tariff bureau of the Atchison, Topeka & Santa Fe at Chicago, has been appointed also chief of the tariff bureau of the St. Louis, Rocky Mountain & Pacific, with headquarters at Chicago.

W. G. Brooks has been appointed soliciting freight agent of the Georgia Southern & Florida, with headquarters at Jacksonville, Fla., and Charles G. Norris has been appointed soliciting freight agent, with headquarters at Macon, Ga., succeeding William Henderson, resigned to go to another company.

M. P. Davis, soliciting agent of the Louisville & Nashville at Birmingham, Ala., has been appointed traveling freight agent, with headquarters at Jacksonville, Fla., succeeding Lee A. Dwelle, who has been transferred to Tampa, and W. T. Westbrook has been appointed soliciting agent at Birmingham, Ala., succeeding Mr. Davis.

#### Engineering and Rolling Stock Officers.

R. W. Pritchard has been appointed assistant superintendent, car department of the Terminal division of the Rock Island Lines, with headquarters at Chicago.

F. T. Beckett, resident engineer of the El Paso & Southwestern, has been appointed engineer maintenance of way of the Chicago, Rock Island & Pacific at El Reno, Okla.

E. P. Weatherley, division engineer of the Kansas City Terminal Railway at Kansas City, Mo., has been appointed engineer maintenance of way, with headquarters at Kansas City.

C. F. Burrell has been appointed engineer and roadmaster of the Kentucky & Indiana Terminal at Louisville, Ky., succeeding J. B. Wilson, engineer, and J. J. McKenzie, roadmaster, resigned.

The title of R. Collett, superintendent fuel service of the St. Louis & San Francisco, has been changed to superintendent locomotive performance. P. O. Wood has been appointed assistant superintendent locomotive performance, with headquarters at Springfield, Mo.

F. L. Burckhalter, district engineer of the Southern Pacific at Portland, Oregon, has had his jurisdiction extended over the Portland, Eugene & Eastern as chief engineer, succeeding R. T. Guppy, resigned to engage in special work for the Southern Pacific at San Francisco, Cal.

A. M. Burt, superintendent of the Northern Pacific at Spokane, Wash., whose appointment as chief engineer maintenance of way, with office at St. Paul, has been announced, was born May 1, 1866, at Syracuse, N. Y. He was educated in the common schools and college preparatory schools of New York and Massachusetts, and entered railway service in the engineering department of the Colorado Midland in March, 1885. He served in various capacities from rodman to assistant engineer for the Colorado Midland, Northern Pacific, Adirondack & St. Lawrence and Chicago & North Western to January, 1897, and from January 1, 1897, to March 1, 1902, was supervisor bridges and buildings of the Northern Pacific at Minneapolis. From March 1, 1902, to October 10, 1903, he was assistant superintendent of the Northern Pacific at Grand Forks, N. D., and from October 10, 1903, until his recent appointment, effective January 1, he has been division superintendent of the Northern Pacific successively at Jamestown, N. D., Fargo, N. D., Missoula, Mont., and Spokane, Wash.

#### OBITUARY.

C. S. Musson, traveling freight agent of the New York, Chicago & St. Louis, at Chicago, died at his home at Wilmette, Ill., on December 14.

James H. Crawford, secretary, treasurer and general manager of the Shippers' Refrigerating Car Company, Chicago, died on December 11, at Chicago.

John W. Thomas, Jr., president and general manager of the Nashville, Chattanooga & St. Louis, died on December 17, at his home in Nashville, Tenn. He was a son of the late Major J. W. Thomas, former president of the road. J. W. Thomas, Jr., was born at Murfreesboro, Tenn., in 1856. After graduating from Vanderbilt College he entered railroad service in 1878, and for the next three years was a locomotive engineer on the Nashville, Chattanooga & St. Louis. In the succeeding two years he was a trainmaster; for two more years, engineer, conductor, operator and office man; for three years to 1889, purchasing agent and secretary to the president and general manager. For the next ten years he held the positions of assistant general manager and purchasing agent, becoming general manager in 1899. In 1906 he advanced to the presidency of the road, holding also the position of general manager.

Mitchell D. Rhame, for many years connected with the engineering department of the Chicago, Milwaukee & St. Paul, died at his home in Minneapolis on December 9. Mr. Rhame was born October 12, 1846, at East Rockaway, New York. He graduated from Yale in 1869, and then took a one year post-graduate course at Sheffield Scientific School. Upon leaving school Mr. Rhame entered the service of the United States government as assistant engineer and was assigned to a survey of the Illinois river, with headquarters at Peoria. While at Peoria, W. W. Folwell, president of the University of Minnesota, became interested in him and offered him the position of professor of mathematics and engineering at that institution, which position he held from 1872 to 1880. After severing his connection with the University of Minnesota Mr. Rhame entered the service of the Chicago, Milwaukee & St. Paul as assistant engineer, on March 4, 1881, afterwards holding the titles of division engineer from 1891 to 1905, engineer of construction 1905 to 1908, and district engineer from 1908 to September, 1913, when he resigned on account of ill health. Among the more important works handled by Mr. Rhame during his connection with the railway were the building of the South Minneapolis shops and terminal facilities, the construction of various new lines, the revision and double tracking of the river division from St. Paul to La Crosse, and finally the construction of 200 miles of the Puget Sound line from the Missouri river to the Montana state line near Marmarth.

## Equipment and Supplies.

### LOCOMOTIVE BUILDING.

THE NORTHWESTERN PACIFIC is in the market for 4 eight-wheel passenger and 2 ten-wheel freight locomotives.

THE INTERCOLONIAL is said to have ordered 16 consolidation and 10 switching locomotives from the Canadian Locomotive Company. This item has not been confirmed.

### CAR BUILDING.

THE ERIE has ordered 7 mail cars from the Standard Steel Car Company.

THE ILLINOIS CENTRAL is in the market for 150 express refrigerator cars.

THE UNION PACIFIC is inquiring for 4,000 box, 600 automobile and 400 stock cars.

THE LOUISVILLE & NASHVILLE has ordered 18 all-steel passenger cars from the American Car & Foundry Company.

THE PENNSYLVANIA RAILROAD is said to have ordered 16 combination cars from the American Car & Foundry Company. This item has not been confirmed.

THE GRAND TRUNK is in the market for about 112 passenger cars, as was reported in an unconfirmed item in the *Railway Age Gazette* of December 12.

### IRON AND STEEL.

**GENERAL CONDITIONS IN STEEL.**—There is still little room for encouragement in the steel industry. Many mills are operating at but 50 per cent. of their capacity, and indications are that they will make the most of the holidays to close down for a while. Such orders as are placed continue to be of a hand to mouth character. The Pennsylvania, which usually places its large order for rails in October or November, has not placed its order even yet this year. The manufacturers are doing their best to maintain prices, and the fact that concessions bring forth no orders encourages them in their policy. The general impression is that many users of steel will have to come into the market before very long out of sheer necessity. It is expected, however, that when the necessary orders are placed that they will be but small and only to cover temporary needs. It is to be noted that the discussion of the fear of foreign competition has died down. It is still a question whether foreign producers will ever be able to compete in this country on a large scale or not. Under present conditions, however, when prices are so low on this side of the water, it seems hardly possible for them to do so.

### SIGNALING.

The Norfolk & Western plans during the coming year to install automatic block signals on 20 miles of its lines, as follows: Suffolk to Myrtle, 6 miles; Windsor to Dwight, 5 miles and Disputanta to Poe, 9 miles.

The Federal Signal Company has taken the contract to install a mechanical interlocking plant for the Philadelphia & Reading at Roelof, Pa. The machine will have 44 levers. Alternating current track circuits will be installed.

The Atchison, Topeka & Santa Fe plans during the year 1914 to install block signals on about 125 miles of lines in addition to lines already worked under the block system. Electric interlocking plants are planned for Wichita, Kan., 80 levers (north tower) and 72 levers (south tower); Joliet, Ill., 224 levers, jointly with the Rock Island, the Michigan Central, and the Alton; Arcadia, Cal., 36 levers; Oakland, Cal., 60 levers. All of these interlockings are at points where other roads have an interest. The Santa Fe is to install a mechanical interlocking, 16 levers, at the bridge at Sibley, Mo.

## Supply Trade News.

The Railway Utility Company, Chicago, has abandoned its branch office in Vancouver, B. C.

The Long Island Railroad, following a recent electric fire on a trestle track at Jamaica Bay, Long Island, has equipped all of its trains with J-M Fyro fire extinguishers. These are manufactured by the H. W. Johns-Manville Company, New York.

Ray C. Lillibridge, Inc., New York, contemplate opening an office in San Francisco next year to take care of the interests of some of their clients in anticipation of the Panama-Pacific Exposition. The New York office, however, will not be abandoned or made subordinate to the new one.

The Ft. Dodge, Des Moines & Southern has for sale two second hand Saxxy & Farmer interlocking plants. One is of 16 levers, with 13 working, and the other is of 20 levers with 18 working. Further details and diagrams may be obtained by application to F. M. Johnston, purchasing agent, Boone, Iowa.

The Procter & Gamble Company, Ivorydale, Ohio, has a locomotive for sale. The locomotive has four driving wheels, 50 in. in diameter, and a weight on the drivers of 50,000 lbs. The cylinders are 14 x 22 in., and the steam pressure is 135 lbs. There is also a separate tender with a capacity of 1,200 gals. of water and a ton of coal.

T. A. Griffin, president of the Griffin Wheel Company, Chicago, has been elected chairman of the board of directors, and W. F. Whitcomb, vice-president, has been elected president of the company to succeed him. W. H. Snedaker, local manager of the company's plant at Tacoma, Wash., has been elected a vice-president, with office at Tacoma.

W. W. Butler has incorporated and is president of the W. W. Butler Company, Ltd., of Montreal, P. Q. The new company will engage in the business of selling railway,

marine and mining supplies; it is capitalized at \$100,000, and will have offices in the Transportation building, Montreal. It will represent J. Stone & Company, Ltd., of London, who manufacture complete systems of electric train lighting; the Canadian Gold Car Heating & Lighting Company, Ltd. It will also represent the American Steel Foundries in Canada, and will have the railroad selling agency for the Glidden Varnish Company. Mr. Butler will retain his interest in the Canadian Car & Foundry Company, the Canadian Steel Foundries, Ltd., and the Pratt &



W. W. Butler.

Letchworth Company, Ltd. He has in addition taken a controlling interest in the Dominion Lubricating Oil Company. With him is associated George T. Merwin, who formerly represented the Safety Car Heating & Lighting Company in Canada.

A bankruptcy sale of the assets of the Beaver Dam Malleable Iron Company, Beaver Dam, Pa., will be held at the office of the company at 2 p. m. on January 3. Lawrence Fitch, of Milwaukee, the largest unsecured creditor, has issued a circular letter to the other creditors in which he announces that he and some of the other principal creditors have decided to bid at the sale, and if they buy the property to organize a corporation. Each creditor will be allowed to subscribe to the purchase price, etc., in proportion to the amount of his claim.

Robert Christy Totten, president of the Nickel Chrome Car Wheel Company, Pittsburgh, Pa., died recently. Mr. Totten was born in Pittsburgh on January 6, 1833, and lived in



R. C. Totten.

that city his entire life with the exception of three or four years spent in St. Louis. His father was one of the earliest iron founders in the Pittsburgh region and organized the old Fort Pitt Foundry, which did a great deal of work for the United States Government during the Mexican war in the casting of cannon. At the death of his father, which occurred in 1850, Mr. Totten, then only about 17 years of age, entered the foundry and continued in that business until about 1891. Since that time he had been engaged, to a greater or less degree, in the study of metallurgy, especially in connection with improvements in chilled iron castings. At the time of his death he was engaged in exploiting an invention relating to the addition of nickel and chrome to chill iron for the manufacture of car wheels.

#### TRADE PUBLICATIONS.

**FURNACE SERVICE.**—The W. S. Rockwell Company, New York, has issued a booklet which aims to show what the company can do in way of furnace service for industrial heating operations.

**AUTOMATIC COUPLERS.**—The Durbin Automatic Train Pipe Connector Company, St. Louis, has published a booklet describing the Durbin automatic train pipe connector and illustrating its use.

**DRILLS AND REAMERS.**—The Rich Tool Company, Chicago, has issued a booklet devoted to that company's line of twist drills, reamers, flat drills, etc. As is usual with drill catalogs the booklet is well illustrated and attractive.

**FORGING MACHINES.**—The National Machinery Company, Tiffin, Ohio, has issued a folder describing the National heavy pattern forging machine. This machine includes some radical departures from and improvements over previous types.

**ELECTRIC MOTORS.**—The Sprague Electric Works of the General Electric Company, New York, have devoted bulletin No. 247 to describing that company's line of round type direct current motors, illustrating several ways in which they may be used.

**PLANING MACHINES.**—The Betts Machine Company, Wilmington, Del., has issued a 40-page catalog devoted to Betts planing machines. The booklet contains illustrations of the several machines as set up and ready for service. It aims, also, to give the reader an idea of the size of the work for which each planer is best adapted.

**AIR COMPRESSORS.**—The Ingersoll-Rand Company, New York, has recently issued an attractive booklet entitled, Story of the Imperial. The little catalog aims to show in a rather unique fashion, the superior points of design and construction maintained in the Imperial air compressors. It illustrates to the reader the various stages of construction and gives a concise and elaborate idea of just how the machines are built.

**LOCOMOTIVE LUBRICATORS.**—The Detroit Lubricator Company, of Detroit, Mich., has recently published a 56-page booklet devoted to a description of the Detroit Bullseye Locomotive Lubricator. In it the company illustrates its line of locomotive lubricators, air cylinder lubricators, and other Detroit locomotive specialties. Included, also, are explicit instructions for operation, which enable the reader to make comparisons of an important kind with other machines of like character.

## Railway Construction.

**ALBERTA, PEACE RIVER & EASTERN.**—According to press reports financial arrangements have been made in London, Eng., to build this line. The company was organized to build in Canada from Hudson Bay across the Peace river district to the Pacific coast. H. M. King, vice-president, and H. H. Williams, chief engineer, Edmonton, Alta. (November 8, 1912, p. 906.)

**ALTON & SOUTHERN.**—An officer writes that work is now under way by the List & Gifford Construction Company, Kansas City, Mo., and the Myers Construction Company, St. Louis, building from the present end of track to the Madison county line, two miles. (August 15, p. 313.)

**BIRMINGHAM, ENSLEY & BESSEMER (Electric).**—An officer writes that this company during 1913 built five miles of new lines between the suburbs of Birmingham, Ala. The work was carried out by the Tidewater Construction Company, Birmingham, Ala. Surveys are now being made to complete the line from Birmingham to Bessemer.

**CANADIAN PACIFIC.**—Work is now under way building an extension of the Esquimalt & Nanaimo from Little Jualienne river, B. C., to Courtenay, 36.5 miles. Contracts for the grading and trestle work have been let to Moore & Pettrick, Victoria, B. C., and for the steel bridges to the Canadian Bridge Company, Walkerville, Ont.

**CARY, NORTH & SOUTH.**—An officer writes that work will probably be resumed early next spring on the line from Cochran, Ga., to Cary, 10 miles. Grading work has been finished on seven miles. The plans call for an extension from Cary to Toombsboro, about 29 miles. D. B. Dunn, chief engineer, Macon, Ga.

**CAROLINA & GEORGIA.**—This company, which is building a line from Augusta, Ga., northeast to Columbia, S. C., 75 miles, has amended its charter, it is said, and will build a branch from Johnston northwest to Greenwood, about 40 miles. Both steam and electricity may be used as the motive power. J. U. Jackson, president, Augusta, and F. E. Courtney. (May 2, p. 1013.)

**CENTRAL UTAH.**—Under this name a line is to be built, it is said, from Salina, Utah, east through Salina canyon to coal fields, about 20 miles. Surveys are now being made, and the company expects to have the work under way this winter. W. O. Creer is president.

**CHARLESTON NORTHERN.**—Incorporated in South Carolina to build a 57-mile line from a point on the Georgetown & Western southwest through the counties of Georgetown, Berkeley and Charleston to the city of Charleston, S. C. It is expected that construction work will be started soon, and that the line from Charleston to Andrews will be open for operation in 1914. D. T. McKeithan, president, Darlington, W. R. Bonsal, of Hamlet, N. C., president of the South Carolina Western and the North & South Carolina, is said to be interested.

**ELBERTON & EASTERN.**—An officer of this company, which operates a line from Elberton, Ga., southeast to Tignall, 21.8 miles, writes that in addition to the extension to be built from Tignall east to Lincolnton, 17.5 miles, the company has projected an extension from Tignall south to Washington, 12.5 miles. Alex. W. Wilson, chief engineer, Elberton. (July 4, p. 36.)

**ESQUIMALT & NANAIMO.**—See Canadian Pacific.

**INTERURBAN RAILROAD.**—This company has filed a charter in Louisiana with \$100,000,000 capital, to operate lines in New Orleans and other parishes of Louisiana. The plans call for building from New Orleans west to Kenner, Jefferson parish, thence to St. Charles parish, about 14 miles, and eventually an extension northwest to Baton Rouge, about 90 miles. The directors include C. G. Tinsley, H. G. Dufour, W. C. Dufour, S. Jackson, Charles Janvier, New Orleans, and C. H. Ellis, New Orleans.

**JOLIETTE & LAKE MANUAN COLONIZATION.**—The Canadian parliament is being asked to extend the time for the construction of lines in the province of Quebec from Joliette, northerly to Ste. Emilie de l'Energie and thence north by northwesterly to St. Michels des Saints, and to Lake Manuan, and from Joliette

southerly through the southeastern part of Montcalm county and L'Assomption and Hochelaga counties to Montreal. A contract was let about a year ago to R. J. Craig, Cornwall, Ont., to build the section from Joliette to St. Michels des Saints, about 60 miles. Location surveys were also undertaken for a further 90 miles from St. Michels des Saints to Weymontachene on the National Transcontinental. The general route map for the entire line from Joliette to the National Transcontinental has been approved of by the Canadian Minister of Railways, and a contract has been entered into between the company and the government for the construction of 30 miles of the line, under the act granting aid in the construction of railways. The general contractors are the Enterprise Construction Company, New York and Ottawa. J. N. Patton, Transportation building, Montreal, Que., is chief engineer.

**LYNDHURST LUMBER COMPANY'S LINE.**—An officer writes that the company is building with its own men an extension from Junction, Mill Creek, Va., to North Fork, 10 miles. G. S. Briggs, president, Lipscomb, Va. (See Virginia Roads, May 9, p. 1053.)

**OKLAHOMA ROADS.**—The Sapulpa Commercial Club has under consideration a proposition submitted by former Governor Charles N. Haskell, to build two lines into Sapulpa, Okla. One line is projected from Sapulpa south to a connection with the Missouri, Oklahoma & Gulf at Henryetta, and the other is to be built west to connect with the Santa Fe and the Missouri, Kansas & Texas at Cushing.

**OREGON ELECTRIC.**—An officer writes that during 1913 this company laid 5.8 miles of main track from Orenco, Oregon, to Bowers Spur, and 6.6 miles of second track from Portland to Garden Home.

**PACIFIC ELECTRIC.**—An officer writes that during 1913 this company completed work on 28 miles of new lines, also on 3.77 miles of second track and sidings at various points in California. Construction work is now under way on extensions between Up-land, Cal., and San Bernardino on 23.30 miles; in Riverside on 2.54 miles; from Santa Ana to Orange on 1.64 miles; from Hawthorne to El Segundo, on 4.44 miles, and from Tropico to Glendale, 2.66 miles.

**TEXAS ROADS.**—Plans are being made by residents of Brenham, Tex., and Independence, it is said, to build a line from Brenham northwest to Independence, about 12 miles.

**TRISTATE TRACTION.**—Plans are being made by this company, it is said, to build a line from Burlington, Iowa, southeast to East St. Louis, Ill., about 150 miles. It is understood that construction work will be started early next year at five different points. Steam is to be used as the motive power for freight service and electricity for passenger service. R. O. Marsh, president, Warsaw, Ill.

**WARREN, JOHNSTONVILLE & SALINE RIVER.**—This company is making surveys for an extension in Arkansas to a point on the Saline river, six miles.

**WASHINGTON ROADS.**—According to press reports residents of Blaine, Wash., will build a railroad from Blaine east to Lynden, 18 miles. Blaine tidelands have been bought for terminals.

**AN ENGLISH RAILWAY SIGNALING SCHOOL.**—On November 3 the London, Brighton & South Coast inaugurated a school for instruction in railway operation and signaling at Croydon. The equipment of the school is very complete. It includes a 47 ft. model of a railway and junction with main and branch lines, a siding and a crossover. This model railway is fully signaled and provided with facing-joint locks, detector bars, indicators as at any similar junction on the railway itself. The signals and connections are all properly interlocked and worked from a full-size 24-lever frame, as in the case of an ordinary signal tower. Two model trains are provided to run on this road, one a passenger and the other a freight. The cars and engines are painted in the usual London, Brighton & South Coast colors. Included in the other apparatus are a complete set of Tyer's block signaling instruments, a set of the more up-to-date Sykes' lock and block signaling apparatus, both of which are in use on the road, and an electric staff system. The object of the school is to enable men to learn signaling and operation without having to go into the regular signal towers.

## Railway Financial News.

**CANADIAN NORTHERN.**—*The Commercial & Financial Chronicle* prints the following as having been authoritatively revised:

"In the legislature at Edmonton quite recently Premier Sifton announced that the government had raised the bond guarantee from \$13,000 to \$15,000 per mile on approximately 600 miles of railway of the Canadian Northern (of which 470 miles was almost complete), located in southern Alberta. The average cost of the line is said to be from \$24,000 to \$30,000 per mile. Bills were also passed guaranteeing the bonds of the Canadian Northern Western line from Blackfalds to the Brazeau coal fields, at \$25,000 per mile for 114 miles (now built, except about 24 miles). The premier stated that the Canadian Northern Western asked for the guarantee of the Brazeau line, which has not hitherto been guaranteed, in order that their capital might be liberated, so that they could proceed with the building of other lines, especially those in the southern portion of the province."

**CHICAGO & EASTERN ILLINOIS.**—The receivers have asked permission of the court to issue \$2,000,000 6 per cent. six months' receivers' certificates. The issue, it is understood, will be brought out by the Equitable Trust Company, and if this plan is carried out there will be outstanding \$6,000,000 receivers' certificates.

**CLEVELAND SHORT LINE.**—The syndicate which bought last September \$5,000,000 Cleveland Short Line first mortgage 50-year 4½ per cent. bonds guaranteed by the Lake Shore & Michigan Southern, and took an option on \$6,800,000 more, has been dissolved, having sold, it is said, \$7,500,000 of the bonds, and the remaining \$4,300,000 bonds have been withdrawn by the company and will not be sold at present.

**DETROIT, TOLEDO & IRONTON.**—The two committees, representing respectively the Northern and Southern divisions, of the Ohio Southern division have agreed on a plan by which the two pieces of property will be operated as one road.

**ILLINOIS CENTRAL.**—Kuhn, Loeb & Co., New York, have bought and are offering to the public \$10,000,000 5 per cent. joint refunding bonds. Of these bonds the bankers are offering \$5,000,000 to investors in the United States at par.

**MISSOURI, OKLAHOMA & GULF.**—On application of the Baldwin Locomotive Works, the company was placed in the hands of a receiver. William Kenefick, president, was made receiver. Oklahoma papers give as the underlying reason for the receivership the recent failure of a Paris bank. There are outstanding \$7,007,000 Railway first mortgage bonds, \$1,467,000 Railway second mortgage bonds, \$10,655,200 Railroad first mortgage bonds, \$350,000 Texas company first mortgage bonds, and \$75,000 Kansas company first mortgage bonds; the Texas and Kansas companies' bonds being deposited under the Railroad company's first mortgage bonds.

**ST. LOUIS & SAN FRANCISCO.**—Judge Sanborn, of the United States Circuit Court in charge of the St. Louis & San Francisco receivership, has set a hearing for December 22 at St. Louis for testimony and arguments on the petitions filed on December 9 by stockholders and the receivers of the road for permission to file suits against former officers and directors for restitution of profits alleged to have been made in the sale of subsidiary lines to the Frisco. The petition of the receivers asked instructions from the court as to whether such a suit should be filed.

**WABASH.**—Thomas B. Fauntleroy, special master, has reported to the federal district court that the Wabash is in default principal and interest in the payment of \$44,830,000 and recommends that the trustee for the first refunding and extension mortgage be adjudged to be entitled to a decree providing for the foreclosure sale of the entire property subject to prior liens.

**WABASH-PITTSBURGH TERMINAL.**—On December 18 a conference was held between the two committees representing holders of Wabash-Pittsburgh Terminal first mortgage bonds. Presumably this conference is held in anticipation of an early foreclosure sale.

See also Wabash.

# Railway Age Gazette

PUBLISHED EVERY FRIDAY AND DAILY EIGHT TIMES IN JUNE, BY THE  
SIMMONS-BOARDMAN PUBLISHING COMPANY,  
WOOLWORTH BUILDING, NEW YORK.

CHICAGO: Transportation Bldg. CLEVELAND: Citizens' Bldg.  
LONDON: Queen Anne's Chambers, Westminster.

E. A. SIMMONS, *President.*  
L. B. SHERMAN, *Vice-President.* HENRY LEE, *Sec'y & Treas.*  
The address of the company is the address of the officers.

### EDITORS.

SAMUEL O. DUNN, *Editor.*

ROY V. WRIGHT, <i>Managing Editor.</i>	H. H. SIMMONS	C. W. FOSS
W. E. HOOPER	H. F. LANE	F. W. KRABER
B. B. ADAMS	E. A. AVERILL	A. D. CLOUD
E. T. HOWSON	R. E. THAYER	GEORGE L. FOWLER
	A. C. LOUDON	

Subscriptions, including 52 regular weekly issues and special daily editions published from time to time in New York, or in places other than New York, payable in advance and postage free:

United States and Mexico.....	\$5.00
Canada.....	6.00
Foreign Countries (excepting daily editions).....	8.00
Single Copies.....	15 cents each

Engineering and Maintenance of Way Edition and four Maintenance of Way Convention Daily issues, North America, \$1.00; foreign, \$2.00.

Entered at the Post Office at New York, N. Y., as mail matter of the second class.

WE GUARANTEE, that of this issue 8,300 copies were printed; that of those 8,300 copies, 6,659 were mailed to regular paid subscribers and 850 were provided for counter and news companies' sales; that the total copies printed this year to date were 450,559—an average of 8,664 copies a week.

VOLUME 55. DECEMBER 26, 1913. NUMBER 26.

## CONTENTS

EDITORIAL:	
Editorial Notes .....	1209
Mr. Yoakum's Statements.....	1210
National Railways of Mexico.....	1211
New Books .....	1212
LETTERS TO THE EDITOR:	
Probable Results of Government Ownership; by Paul M. La Bach..	1214
MISCELLANEOUS:	
Progress in Locomotive Design.....	1215
Passenger Conditions and Their Relation to the Public; by George W. Boyd .....	1220
*High Cantilever Bridge in Mexico.....	1222
Demurrage as a Remedy for Car Shortages; by James O. Klapp.....	1225
Interstate Commerce Commission's Annual Report.....	1228
Preliminary Considerations in the Design of Opening Bridges; by H. G. Tyrrell.....	1230
The Congestion on the Prussian State Railways in 1912; by G. Allix .....	1232
Report of Chief Inspector of Locomotive Boilers.....	1233
Plan for a Uniform Freight Rate Structure and Method of Stating Rates .....	1234
Foreign Railway Notes .....	1214, 1227, 1235
GENERAL NEWS SECTION.....	1236

\*Illustrated.

THE report of the chief inspector of locomotive boilers for the year ending June 30, 1913, indicates a very considerable improvement in the condition and safety of locomotive boilers, as well as a splendid spirit of co-operation between the department and the railways generally. An abstract of this report will be found on another page of this number. It contains one radical recommendation as to the extension of the work of the inspectors. These men in connection with the inspecting of the boilers often notice defects on other parts of the locomotive and tender which may cause accidents and derailments. For some time the inspectors have been noting the more prominent of these defects and calling them to the attention of the mechanical

department officers in charge. The request is now made that Congress confer sufficient authority upon the division of locomotive boiler inspection so that the inspectors may require repairs to be made to any part of the locomotive or tender which may be found in an unsafe condition. While this will increase the responsibility of inspectors and may require some additions to the force, the chief inspector is of the opinion that it will not increase the cost of the department beyond the maximum which is now fixed by law.

THE progress in locomotive design in this country during the past year has been very largely along the lines of improvement and refinement, tending toward greater economy in operation and maintenance. The rapid and general introduction of the superheater, the better understanding of the principles of combustion and how to apply them, the lessons learned from the experiments made at the locomotive testing plant at Altoona, the improved qualities of material that can now be obtained, as well as the data on the actual service of large locomotives, have all offered the designers so many opportunities and so much valuable information that the year's work has been principally that of assimilating and putting it to practical use. There has been little of a spectacular nature in the improvement of locomotives, but the advance has been real and large. Locomotives now being built haul larger trains at higher speeds, with a lower cost for fuel per ton mile, than do those built last year. They are better designed, more reliable and need fewer repairs. What has actually been done and how the results have been accomplished is told in a study of the general locomotive design situation given in this issue.

PROBABLY nothing else has excited public opinion against the railways of this country more than the periodical congestions of freight traffic familiarly known as "car shortage." Those who see in state socialism a specific for all the economic and social ills to which flesh is heir, have based on these conditions an argument for government ownership of railways. On another page of this issue we give an article from the *Journal des Transports* regarding the congestion of traffic on the Prussian state railways in 1912, which should disabuse all minds of the impression that government ownership will prevent or mitigate car shortages or congestions of traffic. The conditions which existed on the Prussian state railways in 1912, and which are described in the article referred to, probably have never been equalled in the United States for acuteness or for loss and inconvenience caused to shippers and the general public. Furthermore, the traffic congestion of last year, while the worst which ever occurred in Prussia, is by no means the first that ever occurred there. Serious congestions and delays, due to the failure of the Prussian government adequately to develop the facilities of the railways repeatedly have occurred within the last 10 years. The reader who peruses the two series of articles advocating government ownership of railways, which have been running in popular magazines, will have no difficulty in finding in them references to the car shortages in this country; but he will look in vain for any reference to the car shortages on the Prussian state railways.

COMMISSIONER PROUTY, in the New England report noticed last week, page 1201, made a significant declaration in favor of raising the mileage-ticket rate from two cents a mile to 2¼ cents. The report recognized that the change could not be put into effect at present, and perhaps not at all, because of laws in some of the states making the two-cent rate compulsory; but the fundamental economic principle—that mileage-ticket passengers could equitably and reasonably bear a larger share of the cost of maintaining the Boston & Maine, as compared with the freight traffic, and as compared with passengers who buy tickets one at a time—is explicitly recognized. This is a refreshing change from



the universal demand that passenger fares shall be forever reduced, and that the drummer, with his fictitious claim that his patronage ought to be treated as wholesale, shall have the lion's share of all reductions. On the other hand, the Railroad Commission of Louisiana in its decision reported on page 1204, surrenders completely to the drummer demand. The commissioners started out to reduce all fares from three cents a mile to 2½ cents, but the railroads and the commercial travelers got together and fixed up the usual scheme to favor them—the commercial travelers—and others who can afford to buy \$25 worth of transportation at one time, and the commissioners withdrew their proposal. How will this ignoring of "the poor man" look when those commissioners are up for re-election? Still another novelty in the traffic field was noticed in our last issue: the recommendation of Hon. Seth Low, of New York, that the railways reduce passenger fares still further. The voter feels the cost of passenger fares, but does not feel the cost of freight transportation; hence a concession to him in fares will do much more good than a reduction in freight. It is gratifying to see evidence that publicists do some real thinking on this subject, and especially that so honest, broadminded and public spirited a man as Mr. Low is willing to speak his mind in public; but it is to be feared that his present dictum can only be treated as a pretty theory. Admitting that his theory has a rational basis, how far will he be willing to carry it when he sees, as he will see if he goes far in his studies, that most or all of the fares that he has in mind are already so low that the profits are almost or quite invisible? In putting freight burdens on passengers or passenger burdens on freight, a carrier can justly deal only with a community as a whole, and in dealing in that way many individual injustices are unavoidable. These injustices are tolerable only because they are small.

**I**N Massachusetts locomotive engineers have been annoyed by the red lights of automobiles. According to the chairman of the Massachusetts Highway Commission, an official body which deals with questions relative to the regulation of automobiles, engineers report that they have in some cases, while running around a curve, brought their trains to a stop because of a red light which they feared was a switch light. What the Massachusetts authorities are going to do about it is not stated. It has been proposed that automobile tail lights should be of some other color; but it does not seem likely that a legal requirement of that nature would be easy to enforce. Yellow is the only suitable color that is available. A law would meet with resistance or neglect, or both, and would be justly open to some objection as a disproportionate burden; thousands of lights to be changed to obviate a very few possible dangers. Again, the railroads themselves use red lights inconsistently; there were difficulties from deceptive signals before automobiles were known. And, whether the trouble be great or small, whether it be due to automobiles or to poor practice, or badly designed structures or appliances on the railroads, there is one remedial means which must always be striven for, namely, to provide fixed signals distinctive in character, and sufficient in number, to safely conduct all trains over the road in spite of outside disturbances of any kind, whether these be few or many; in spite of any number of undesired red lights. A rational and practicable fixed signal system could be made without using any red lights at all, except on high posts, in pairs; that is, arranged so that no foreign red light could be mistaken for the railroad signal. Every switch should have a distant signal. The present standard aspects of the Railway Signal Association afford nearly or quite the ideal. With signals on posts of sufficient height, the situations where automobile or other lights could confuse the aspect of these standard lights would be exceedingly rare, and could be specially provided for. There are places, no doubt, where the simplest safeguard against

confusion is to provide additional fixed signal posts. The ideal signal system forbids the engineman to proceed unless he sees the all-clear (green) signal; this rule, strictly interpreted and enforced, makes the red light unnecessary (though it does not forbid the use of red as a marker); and the corollary of this conclusion is that an automobile light need not alarm the engineman. For emergency red signals—as when a track repairer must stop a train because of a washout—the invariable practice should be to swing the light; and lights on automobiles do not swing. We do not wish to do anything to encourage the automobilist to think that he can rule the railroads like a despot, as he rules the highways; but it is only reasonable to recognize that this new difficulty does not present an entirely new problem. One of the everyday problems of the locomotive runner is that of making time with a fast train in spite of the frequent occurrence of sights and sounds which *might* be taken as indications to stop or to slacken speed; and the best way to mitigate this difficulty of the runner is to give him the fullest possible assurance, when he passes a given point, that the track is clear for him to a certain given point farther on. We cannot tell him to ignore red lights; but we can make it easier for him to decide what interpretation to put on stray lights.

#### MR. YOAKUM'S STATEMENT.

**T**HE *Railway Age Gazette* published last week (December 19, page 1197) the statement issued by B. F. Yoakum, chairman of the board of directors of the St. Louis & San Francisco, explaining the transactions by which the St. Louis, Brownsville & Mexico, and other railway properties in the southwest in which Mr. Yoakum and some other directors of the former road were interested, were sold to the St. Louis & San Francisco. Mr. Yoakum states that his original subscriptions to the roads which were sold to the St. Louis & San Francisco aggregated \$810,833; that his total profits on the various transactions were \$288,117, and that his profits in excess of 6 per cent. interest on his capital during the time it was invested in the subsidiary properties amounted to \$151,152. The periods during which Mr. Yoakum had his capital invested in the subsidiary companies varied from 1901-'03 to 1909.

Mr. Yoakum argues that the construction of the small lines in the southwest by separate companies was the only practical way for developing them. Doubtless this is correct. The laws of Texas are such as to make the construction of new lines in that state by foreign corporations very difficult, if not practically impossible.

In order properly to appraise other features of Mr. Yoakum's statement it is essential to bear in mind the relation in which he stood at the time of these transactions to the bondholders and stockholders of the St. Louis & San Francisco. He was a director in the corporation, and chairman of its board. He was, in other words, the principal man whom the owners of the property had employed and trusted to protect and promote their interests to the utmost in every proper way. His obligation and duty were, therefore, to serve their interests in every way with singleness of purpose and to the very best of his ability. Above all things else, it was his function to make profits *for* not *from* them.

Now, if, in selling properties to them, in which he was interested, he had taken only the principal of and interest on his original investment, no just criticism could be made against him; he would then have neither profited nor lost by the transaction. But, according to his statement, he and his associates sold their properties to the St. Louis & San Francisco at prices which not only covered his principal and interest, but yielded a large profit besides. There are still communities where a profit, over interest, of \$151,000 on an investment of \$810,000 is considered quite substantial. Mr. Yoakum's course in using his fiduciary position to make this, or any, profit out of those who had employed and

trusted him cannot be defended in the court of public opinion or morals, whether it can or cannot be in a court of law.

In a mixed tone of admission and defense Mr. Yoakum says he is aware that public opinion has changed regarding many business methods, the use of which formerly was widely prevalent. That is true; but it is not defense, or even extenuation, in his case. For the transactions which have brought criticism on him were begun in 1901 and continued up to 1909. Now, the law of corporations long before the first of these years, condemned directors or other fiduciary officers of corporations who used their positions to profit at the expense of their employers, and the change in public opinion to which Mr. Yoakum alludes came long before the date on which these various deals were consummated.

Mr. Yoakum's statement is not a defense; it is a confession. He is not a victim of a change in public opinion; he is suffering from the effects of having ignored a public opinion which long had frowned on the use of such business methods as he admits having used. And while he is suffering, all the railways and railway men of the country are suffering from the undeserved odium which what is now familiarly known as the "Frisco scandal" has brought upon the entire railroad business.

Meantime, in order that no injustice may be done, it is but fair to call attention once more to the fact that under Mr. Yoakum's management the personnel of the Frisco's official staff has been of the highest character; that the property has been managed skilfully and economically and that its service has been good. In other words, criticism of the road's financial management does not imply criticism of its management in other respects, which, considering all conditions, has been excellent.

**NATIONAL RAILWAYS OF MEXICO.**

IN the annual report for the fiscal year ended June 30, 1913, the chairman, speaking for the board of directors, praises highly the work of the active management and especially of Mr. Brown for the services rendered in a year of very great difficulty. The praise is apparently well merited. Operating problems in the past year must have been almost innumerable and a management with less courage and less resourcefulness might well have found them insurmountable. Nevertheless, the company earned \$28,685,000\* in 1913, as against \$30,724,000 in 1912, and after the payment of expenses, amounting to \$18,122,000 in 1913, as against \$19,217,500 in 1912, and taxes and rentals, there was available for interest \$10,673,000, as against \$10,944,000 in 1912. The saving in expenses was made entirely in maintenance of way and structures, but maintenance of way was abnormally high in 1912, because during that year the company charged the cost of replacing property destroyed by revolutionists entirely to expenses. In 1913, on the other hand, parts of the line were put entirely out of operation by the revolutionists, and during this period of enforced idleness there were no charges, of course, for maintenance.

Maintenance of equipment in 1913, was much higher than would have been necessary under ordinary circumstances. There was spent on this account \$5,058,000, as against \$4,843,500 the year before. These expenses, of course, were adversely affected by the unsettled state of the country and by the difficulty of keeping shop forces organized and the added expenses of repairing equipment wilfully damaged by the rebels.

Transportation expenses amounted to \$8,051,500 in 1913, as against \$7,718,000 in 1912. It is surprising, however, that under the existing conditions, transportation expenses were not increased more largely than they were. The following table shows the percentage of each class of expenses to total operating revenues:

	1913.	1912.
Maintenance of way and structures.....	14.08	18.46
Maintenance of equipment.....	17.63	15.76
Traffic and transportation expenses.....	28.07	25.12
General expenses.....	3.40	3.21
Total.....	63.18	62.55

The total number of tons carried was 5,931,000, as against 6,477,000 in 1912, a decrease of 8 per cent. The number of passengers carried was 8,666,000, as against 8,096,000 in 1912, and the total train mileage in both freight and passenger service was

\*The figures given throughout these comments are for U. S. currency, the Mexican dollar being taken at fifty cents.

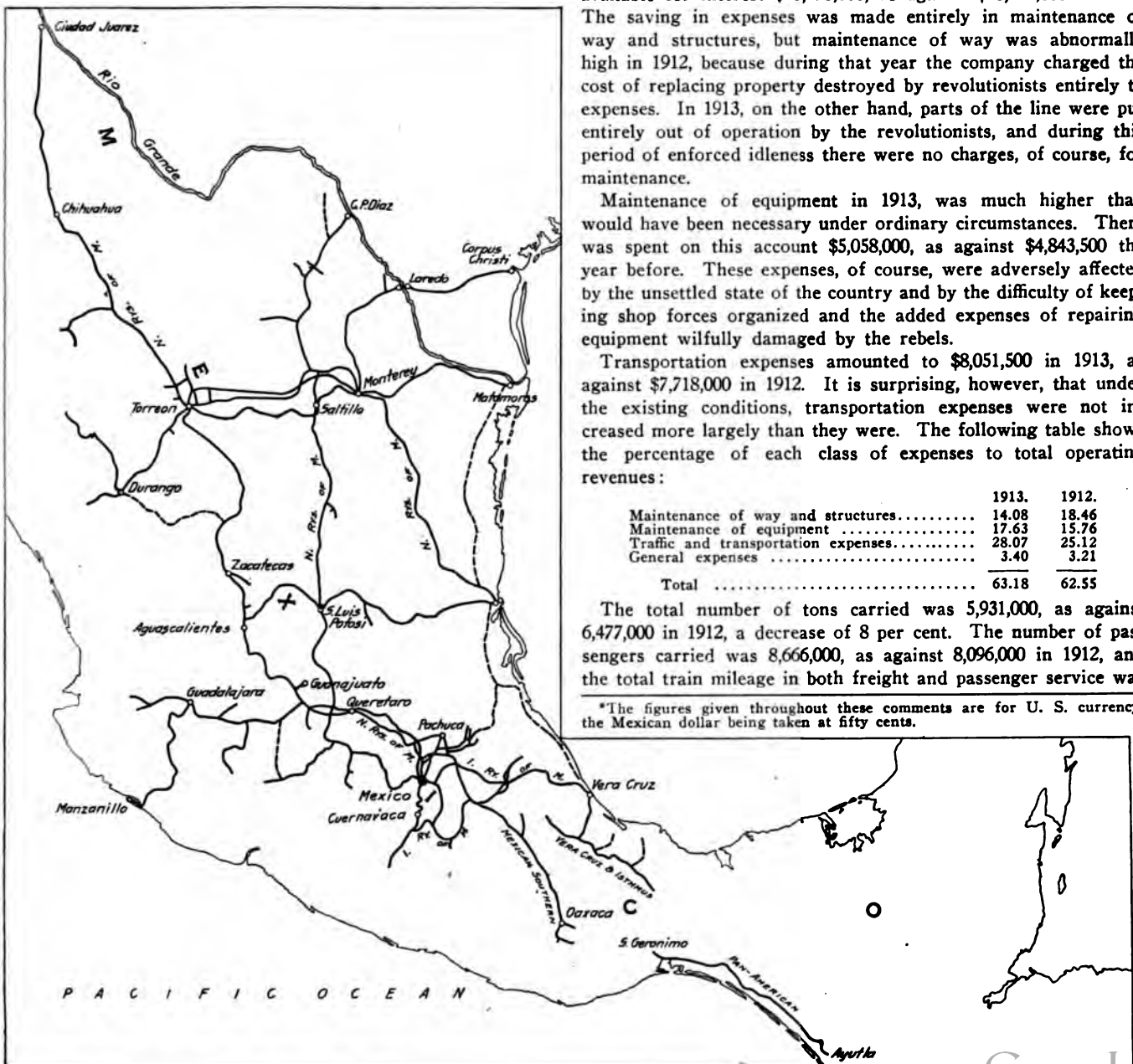

The National Railways of Mexico.

10,209,000 in 1913, as against 11,169,000 in 1912, a decrease of 9.40 per cent. The average train load of freight on the standard gage system was 278 tons in 1913, as against 304 tons in 1912. On the narrow gage system, however, the average train load was 97 tons in 1913, as against 89 tons in 1912. The average receipts per ton per mile for all revenue freight were 1.596 cents in 1913, as against 1.502 cents in 1912. The average receipts per passenger per mile were 1.393 cents in 1913 and 1.440 cents in 1912.

One of the most interesting things about the National Railways' report for last year is the way in which gross earnings held up, even when the whole country was in a state of unrest which amounted in the northern provinces to actual revolution. Of course, some of the freight traffic was created by war conditions; but the changes in character of traffic do not indicate that this was any very large proportion of the total, and it remains true that the volume of traffic carried last year under war conditions speaks well for the possibilities of the property when the country is once more in a state of peace.

Of the total tonnage of freight carried in 1913 by the National Railways 47.31 per cent. was mineral products, 24.71 per cent. agricultural products, 11.80 per cent. products of forests, 11.69 per cent. merchandise, and 4.49 per cent. live stock and animal products. The principal change was a falling off in mineral products of from 3,223,000 tons carried in 1912 to 2,806,000 tons carried in 1913. It is rather interesting to note that coal furnished but 6.54 per cent. of the total tonnage, while ore furnished 17.71 per cent.

While from an earnings and operating point of view the results in 1913 can fairly be considered good, the financial condition of the company is not so good. If it were not for the fact that the company is a national institution which the government is under moral obligations to protect, the balance sheet might be considered showing a rather precarious situation. There was on hand \$8,340,500 cash, but of this \$7,647,000 was deposited for the payment of principal and interest on bonds, etc., or as a guarantee, and there were, on the other hand, notes payable amounting to \$31,837,000. The profit and loss credit balance was but \$49,500, while there is held in suspense interest and discount amounting to \$2,053,000.

Looking back now, it seems as if the directors were hardly justified in having paid 2 per cent. dividends from profit and loss on the preferred stock, but, of course, at that time it was hoped that the company would be able to permanently finance its floating debt. The company has charged as reserve for repairs and renewals against equipment, roadway, bridges, buildings, etc., \$3,809,000, and for equipment depreciation \$2,460,000, and carries these amounts as liabilities. This means that when the earning power of the company is restored it is the purpose of the directors to put the actual money into the restoration of the property from earnings. There was spent during the year \$1,899,500 for additions and betterments.

Since the attempted strike of the Americans in train service in the year 1912, Mexicans have been employed wherever possible, and on June 30, 1913, of the 25,852 employees in service, only 1½ per cent. were foreigners.

The following table shows the principal figures for operation in 1913 compared with 1912:

	1913.	1912.
Average mileage operated .....	7,094	7,047
Freight revenue .....	\$20,184,386	\$21,929,803
Passenger revenue .....	6,470,526	6,774,194
Total operating revenues .....	28,685,141	30,723,896
Maint. of way and structures .....	4,038,319	5,670,017
Maint. of equipment .....	5,058,230	4,943,560
Transportation and traffic expenses .....	8,051,490	7,717,811
Total operating expenses .....	18,121,974	19,217,628
Taxes .....	211,361	239,304
Operating income .....	10,140,807	11,266,964
Gross income* .....	10,672,806	10,944,017
Net income .....	361,781	1,242,288
Dividends .....	576,658	1,153,316
Surplus .....	214,877†	88,972

\*Rentals, amounting in 1913 to \$39,125 and in 1912 to \$35,107, have been subtracted before arriving at gross income, where ordinarily in these columns rentals would be included and not subtracted until after arriving at gross income.

†Deficit.

## NEW BOOKS.

*American Society for Testing Materials. Proceedings of the Sixteenth Annual Meeting, Atlantic City, N. J., June 24-28, 1913.* Cloth, 6 in. x 9 in., 1,141 pages, illustrated. Published by the McGraw-Hill Book Co., New York. Price \$5.

The complete proceedings of the sixteenth annual meeting of the American Society for Testing Materials occupy a large volume which contains a great deal of matter of interest to railway engineers. All of the committee reports and special papers presented at that meeting, with the discussions which followed, are published in full. Railway men will find of special interest, the portions referring to reinforcing bars rerolled from steel rails, wrought steel wheels, steel tires, cold rolled steel axles, specifications for cement, reinforced concrete, the Atlantic City steel paint tests, rail failures and their causes, the autoclave test for cement, and numerous similar topics.

*Laboratory Manual of Testing Materials.* By Wm. K. Hatt and H. H. Scofield. Size 5 in. x 8 in., 135 pages, illustrated, cloth. Published by McGraw-Hill Book Co., New York City. Price \$2.

This new manual of practice for testing materials laboratories is the result of developments in the laboratory of Purdue University. It was published in its original form by Prof. Hatt and later with the assistance of Prof. Scofield, was enlarged and was used in several other universities. The book in its present form has been considerably enlarged and a more complete treatment of machines and apparatus has been added. It is intended to relieve the instructor of the necessity of explaining the details of mechanical procedure, and so allow him to devote more time to duties of greater educational importance. In addition to the descriptions of materials and testing machines and the usual list of experiments which cover iron and steel, wood, cement, aggregates, concrete and road materials, four appendices are included, giving common formulae, strength specifications for steel and iron, standard forms of test pieces and strength tables.

*Overhead Electric Power Transmission.* By Alfred Still, Assistant Professor, Electrical Engineering, Purdue University. Cloth binding, 310 pages, 6 in. x 9 in. Illustrated. McGraw-Hill Book Co., Price \$3.

"Overhead Electric Power Transmission" deals only with long distance overhead transmission lines, leaving to other volumes a discussion of distribution systems, a knowledge of which is, of course, essential to the proper consideration of the economics of transmission systems. The book is designed to reach primarily the practical engineer, and secondarily, the engineering students who wish to specialize in power generation and transmission. In showing the derivation of practical methods and formulae higher mathematics have been avoided in the effort to make the book of the most use to office engineers engaged in making the necessary calculations and drawing up specifications and for the class of engineering students mentioned. It has not been attempted to treat the subject from the standpoint of the construction engineer in charge of erection work. The book is divided into eight chapters, including Introductory and General, Principles and Theory, Economic Principles and Calculations, Electrical Principles and Calculations, Insulation and Lightning Protection, The Transmission of Energy by Continuous Currents, Mechanical Principles and Calculations, and Transmission Line Supports. In Appendix are reprinted some articles dealing with theoretical aspects of long distance transmission, also sets of complete specifications for wooden and steel tower transmission lines.

*International Association for Testing Materials. Proceedings of the Sixth Congress, New York, 1912.* First and second sections. Two volumes, size 6 in. x 9 in., 1,100 pages each. Illustrated. Cloth or paper binding. Published by the McGraw-Hill Book Co., New York. Price, paper binding (2 vol.), \$7; cloth binding (2 vol.), \$8.

The proceedings of the last congress of the International Association for Testing Materials are presented in two large volumes and contain all of the papers and discussions which were pre-

sented before that meeting. The first section includes the report of the organization and the opening and closing sessions of the congress, all of the papers on metals and the discussions of section A, which covers metals. The second section contains the papers on cements, stones and concrete, the discussions of section B covering these subjects, and the papers and discussions of section C covering miscellaneous subjects. These proceedings are published in English, but are also available in German and French.

*Suspension Bridges.* By William H. Burr, professor of civil engineering, Columbia University. Size 6 in. x 9 in. 417 pages. Illustrated. Cloth bound. Published by John Wiley & Sons, New York. Price \$4.50.

"Suspension Bridges" was prepared for use as a text book in bridge engineering and with this in view particular emphasis has been given to elucidating general principles. The author has endeavored to treat each main structure in a general way so as to cover all desired special cases. In order to make the numerous formulae required for the analysis of indeterminate structures readily applicable in actual practice, many numerical tables have been added with the hope that they may be found useful by practicing engineers. The treatment brings out the two generally accepted methods of analyzing stiffened suspension bridges, the one based upon the principle of least work and the method of deflections. The comparison of the results secured by these two methods and the greater ease with which the equations in the former method can be handled leads the author to favor it in his discussion. The chapter heads, which are suggestive of the scope of the work, are as follows: Suspension Bridges; Statistically Indeterminate Stiffening-Trusses; Theory of the Straight Stiffening-Truss Based on the Method of Deflections; Thermal Stresses; Arch Ribs Treated by Graphical Methods; The General Analytic Theory of Elastic Arch Ribs According to the Law of Least Work; Three-Hinged Arch Rib; Braced Spandrel Arch, and Cantilevers.

*Year Book of the American Society for Testing Materials.* Size 6 in. x 9 in., 401 pages, illustrated, cloth. Price \$5. Published by the secretary, American Society for Testing Materials, University of Pennsylvania, Philadelphia, Pa.

Departing from the practice of last year when the proceedings of the society and the year book were published in one volume, the proceedings of the society are not included in this year book, which is devoted entirely to the standard specifications of the society in their latest revised forms. These standard specifications include those for Bessemer steel rails; open hearth steel rails; medium carbon, high carbon and extra high carbon steel splice bars; structural steel for bridges; forged and rolled, forged, or rolled solid carbon-steel wheels for engine, truck tender and passenger service, and also for freight car service; also specifications for wrought iron; for locomotive materials, for cement and for structural timber and yellow pine bridge and trestle timbers. Representative specifications for carbon steel rails and for steel railway bridges are reprinted from the Proceedings of the American Railway Engineering Association, and there are also included the specifications of the Association of American Steel Manufacturers for Bessemer steel rails, structural steel and boiler steel, and those of the United States Steel Products Co. for Bessemer and open hearth steel rails. These standard specifications, covering a wide variety of subjects in engineering and railway practice, and included in one volume, make it a valuable book for reference.

*Strength of Materials.* By Mansfield Merriman. Sixth edition, revised. Illustrated. Bound in cloth. 166 pages. 5 in. x 7½ in. Published by John Wiley & Son, New York. Price \$1.

Merriman's *Strength of Materials* is too well known as a text book to require any extended description. The first edition was issued in November, 1897, and it has now passed to the sixth edition, each being revised to keep pace with the advance of knowledge in this field. In the fifth edition a new chapter was added on reinforced concrete, especially columns and beams, and in the sixth a new chapter on combined stresses has been added.

Numerous changes have been made throughout the book and many new problems have been introduced. This standard work offers an opportunity for the study of the strength of materials, beams, columns and shafts which may be understood by those not acquainted with calculus. The degree of mathematical preparation required for an understanding of the problems presented is merely that now usually given in high schools. The book deals mainly with questions of strength, the subject of elastic deformations occupying a subordinate place. Since the deductions of the deflection of beams are best made by calculus, they are not here attempted, but the results are stated so that the pupil or reader may learn their uses. A chapter on the manufacture and general properties of materials is given as well as one on resilience and impact.

*American Railroad Economics.* By A. M. Sakolski, Ph.D., Staff Lecturer in New York University School of Commerce, Commerce Accounts and Finance. Published by the Macmillan Company, New York. Cloth, 12mo, 295 pages. Price \$1.25.

This is a text book for investors and students, the product of the author's activities as an investment analyst in New York, and as a lecturer on transportation economics. In this volume the railroads are studied as business enterprises. Their operations and activities are equalized and interpreted from an economic and financial viewpoint which involves consideration of legal, statistical and accounting matters. The material is classified under four heads: Data regarding the character of the transportation facilities, including an analysis of the physical features of railways, insofar as they influence operating results; data measuring efficiency and economy of operation, including a consideration of traffic and mileage statistics; data measuring revenues, expenses and net earnings, including a study of the income account and the profit and loss account; data measuring the capital investment in relation to the corporate resources and liabilities, including an analysis of capitalization and the general balance sheet. One chapter is devoted entirely to the Interstate Commerce Commission system of accounting, including the motives for the formulation of the system and a discussion of some of the various opinions on different features of the commission's system. The book should be of great value to railway investors and other persons who have occasion to study railway annual reports, and particularly to the student of railway affairs.

*The Metallography of Iron and Steel.* By Albert Sauveur. Size 7¼ in. x 10¼ in., 436 pages, 366 illustrations, cloth bound. Published by Sauveur & Boylston, Cambridge, Mass. Price, \$6.

This work, is, so far as is known, the first comprehensive treatment of its broad and important subject. The rapidly increasing attention that is being given to the processes of manufacture of iron and steel for the purpose of securing the best available products, should make it of real value to many engineers and railway men. The book is divided into a series of 24 lessons and two appendices, the lesson form of treatment being adopted with a view to the needs of men seeking self-instruction in metallography, although the work is equally well adapted for a text book and should be found valuable by manufacturers and users of iron and steel and expert metallographers. The thoroughness with which the subject is covered is best indicated by the list of titles for the 24 lessons, the more important of which include pure metals, pure iron, wrought iron, low carbon steel, medium high and high carbon steel, impurities in steel, the thermal critical points of iron and steel, cast steel, the annealing, hardening and tempering of steel, special steels, cast iron, malleable cast iron, constitution of metallic alloys and the phase rule. The appendices cover manipulations of apparatus and nomenclature of the microscopic constituents. An introduction covers descriptions of the apparatus used in metallographic laboratories. The illustrations, and particularly the photomicrographs, are especially noteworthy. The book is printed on the best quality of coated paper, which makes possible the use of the best grade of half-tones, and the author has taken great pains to secure the best available illustrations from whatever source.

# Letters to the Editor.

## PROBABLE RESULTS OF GOVERNMENT OWNERSHIP.

CHICAGO, November 28, 1913.

TO THE EDITOR OF THE RAILWAY AGE GAZETTE:

After reading the discussions pro and con (mostly con!) anent government ownership of railways which have appeared of late in the public prints, one is inspired with awe on approaching so august a subject. Like the pious follower of Mahomet at the shrine at Mecca one approaches in fear and trembling because of the mystery surrounding it and the uncertainty as to what it may bring forth—in figures.

The latest pronunciamento from the camp of statesmen, senators, office holders, etc., is that the railroads of the U. S. A. can be bought for 19 billions (it takes less space in words) of dollars. Of anything like a basis in fact this statement is, of course, entirely innocent. Why not satisfy our taste for jugglery by making it 20 billions of dollars? A billion more or less is a mere bagatelle, and if we do not descend into vulgar fractions 20 has twice as many factors as 19, and accordingly offers several times as many opportunities for combinations.

Neither this government, nor for that matter any other government on earth, could borrow 20 billions of dollars in money for any purpose. What would happen would necessarily be an exchange of securities. Somebody would want to trade Penna 4½s selling at 100, or U. P. 4s selling at 95 for government bonds selling at 100 and only paying 3 per cent.

The next line of argument is that the security is better. Why would the government bond secured by the above properties and others not so valuable be given the preference? The real reason is because the government bond is not taxable. The difference in price between securities of the above variety and those issued by the United States is largely due to that element. If the government should undertake to issue bonds paying less than about 4¼ per cent. in order to sell at par, the security underlying these bonds would not only have to include all the railroad property of the country, but also the non-taxable feature. Judging by the press notices our statesmen expect to make these bonds a general liability of the government in addition to the security furnished by the railroad property. In this case everybody, including the holder, may be taxed in order to make up the deficit if the railroads do not pay under government management.

In the opinion of most people who follow public matters our governmental affairs are not likely to become less expensive. This money must be raised by taxation under our present system. The railroads pay as taxes in the different states approximately one hundred millions of dollars per year. One state derives six millions and several five millions from this source. One hundred million dollars is one-half of 1 per cent. on the aforesaid 20 billions.

I do not know what the average personal property tax would be for the entire country, nor what proportion of railroad securities is held in America, but when we consider the different varieties of franchise taxes, income taxes, direct personal property taxes and our complicated system of erecting the taxation pyramid, it would appear that 1 per cent. per year on the 20 billions is a conservative estimate. If the railroads do not produce this money for the public, the public will have to tax itself.

For 1910 the net operating revenue from rail operations was 928 million dollars. This is 4.64 per cent. on 20 billions. A great many arguments can be made on the subject of the government issuing bonds at low rates, but among the well-informed the opinion seems to be that a non-taxable (and otherwise exempt) bond would have to bear 3½ to 3¾ per cent. in order to sell at par. In other words, the cost of the government ownership will be (on 20 billions):

Interest .....	3.5 per cent.
Taxes.....	0.5 per cent. (State on railroads direct.)
Taxes.....	1.0 per cent. (Estimate on personal property.)
Total .....	5.0 per cent.

This is 0.36 per cent. more than for the year 1910, a banner year. The public loses 0.36 per cent. on this immense capitalization unless it can operate the railroads more economically than under private ownership. Does any one believe that this can be done? It is being tried in numerous instances at the present time. The records show that in every case public ownership is more costly than private, even where there is no political interference. We are conducting public business in this country in a very wasteful manner at present. Why should we expect a new undertaking to be different? A good deal is being said about high salaries. If all the general officers were dismissed as useless it would save 18 millions a year. If the same amount was saved in the soliciting of business and 4 millions in the legal department, the entire sum would only be 0.2 per cent. on 20 billions.

Because we have made a bad mess of regulation by having about 50 boards of regulators, that is not a good reason for public ownership. The thing to do is to eliminate about 49 of them. We would then have regulation founded on knowledge which would be applied with wisdom in the long run. The advocates of public ownership say this cannot be done. What chance has a government, which involves itself with legal fictions to such an extent that it cannot extricate itself, got to run a complicated business of immense proportions without getting in a similar tangle? As a matter of fact, all railroads are interstate, that is all of standard gage that handle all the business offered. A man in a small Texas town on a small railroad entirely within the state buys a piano from a dealer in Dallas. Some want to call that intra-state commerce. The piano probably travelled over ten states before reaching Dallas, and the value of the small road lies largely in the fact that it can ship to or receive goods from any point on the map.

The post office is frequently cited as one of the finest exhibits of public ownership. We all know that it usually has a deficit annually. No account is taken of the interest on the appropriations for buildings in making up a balance sheet. The R. F. D. operates over roads that are maintained by taxation. The public pays the bills in the end. The same rule would hold good for a railroad. It must meet all charges, or its indebtedness will be distributed among the citizens at large. The man who would benefit would be the large shipper. The ultimate consumer of few articles which must be transported would find himself in the position of holding the bag for the big fellow.

The whole proposition looks like a sugar-coated pill so far as the public is concerned. No doubt a certain proportion of the people would like to have the balance help them make money by footing the loss on their freight bills, but that is not a very good reason from the other man's point of view.

PAUL M. LA BACH.

A NEW STATION IN BELGIUM.—The government of Belgium has just completed the construction of a fine new station in Ostend, described as of great architectural beauty. The railway has been extended from the station to the new quay, so that passengers pass to and from steamers under shelter. In connection with the new structure, and having access from it, there is a hotel managed by the International Sleeping Car Company.

THE RAILWAYS OF VICTORIA.—Victoria has the largest population of the Australian states, although it is the smallest in area, except Tasmania. All of its public railways, excepting a short line of 14 miles, are now owned and controlled by the state. They are managed by a board of three commissioners, who have supreme control of the administration, and are free from political interference. The construction of new lines, however, is undertaken by the Railway Construction Branch under the control of the Board of Land and Works, which transfers the lines to these three commissioners after completion. During the year ending June 30, last, a length of 25 miles of new line was opened for traffic; 242 miles was under construction at the close of that period. The mileage now open is 3,648 miles.

# PROGRESS IN LOCOMOTIVE DESIGN.

Improvement and Refinement Tending to Greater Economy in Operation Is the Basis of the Designers' Study and Output.

The past year has brought important but not spectacular developments in locomotive progress. There has been much concentration on more effective use of fuel through fuel saving devices and capacity increasing factors and a marked tendency toward maximum power per unit of weight has developed. The important and helpful tendency toward co-operation on the part of engineers of the supply interests should be recognized and is being encouraged.

In a general way, the progress can be indicated and the present situation demonstrated by the following:

(1) Locomotives of the largest size for the different classes of service continue to be built almost exclusively. A beginning has been made toward applying the most economical arrangements and proportions to the lighter locomotives.

(2) Boiler capacity per pound of metal in the boiler has been decidedly increased by the use of larger fireboxes and combustion chambers, thus giving time for the completion of the gas reactions before the flues are reached. Shorter flues, giving a higher rate of evaporation per unit of area, are the result in some cases. Flues, however, in no case, are shortened from the front end and, having the size of firebox and combustion chamber desired, the flues are made as long as the weight limits will permit.

(3) Cylinders are increasing in relative size due to the lower steam consumption at shorter cut-offs when using superheated steam. Stokers are also causing enlarged cylinders because of the increase in the maximum boiler capacity.

(4) Heavier weights are being placed on drivers in connection with the lighter weights of reciprocating parts.

(5) Superheaters and brick arches are almost universally applied to new locomotives and are also being installed on many older designs.

(6) Standardization of the parts most frequently requiring repairs and the use of these parts on new locomotives as far as possible, is being more widely practiced.

In these days of diminishing and disappearing net earnings, higher average train loads must be handled. Locomotives are now being called on for results which but a few years ago would have seemed absolutely impossible. The locomotive designers are meeting the demand and are producing Atlantic type locomotives which do as much work and haul as large trains as the Pacific type did two years ago; consolidations which perform the service that demanded Mikados in 1911, and all classes which will pull from 10 per cent. to 30 per cent. larger trains on the same amount of coal used two or three years ago. At the same time, if allowance is made for increases in wages and the increased cost of material, the cost of repairs per unit of work has been actually decreased.

The general use of the superheater and brick arch is largely responsible for this improvement, but the adjusting of all parts to the best relationship, one with the other, has been effective in continuing the improvement.

In general the problem has been to obtain the greatest drawbar pull at the highest practical speed for the service with the least total weight of locomotive. Sustained drawbar pull depends mostly on boiler capacity, and in this direction great

strides are being made. While the ratio of output in steam to the weight of the boiler is increasing, still the total weight of the boiler also continues to increase. This, in turn, means greater weight on the wheels, most of it coming on the drivers. In high or moderate speed service the permissible dead weight on drivers is controlled by the hammer blow of the excess weight in the counterbalance which is controlled by the weight of the reciprocating parts. The weight of these parts is dependent on the amount of power delivered by the cylinders, and thus the cycle is complete.

Better quality of material allows some saving of weight, and when combined with perfect design, it has permitted the use of larger boilers and heavier dead weight on drivers without exceeding the safe limits.

While there has not actually been built this year a locomotive which exceeds in total weight the 2-10-10-2 type built by the Santa Fe in 1911, which weighs 616,000 lbs., or the Virginian 2-8-8-2 type built by the American Locomotive Company in 1912,

which weighs 540,000 lbs., still the average weight of new locomotives built continues to increase. Selecting ten typical examples of the 2-8-2 type built during the year, shown in the accompanying table, the average total weight is seen to be 293,020 lbs. The average for ten Pacific type engines is 273,130 lbs., and for four typical consolidations the average weight is 246,875 lbs.

## FEW ARTICULATED LOCOMOTIVES BUILT.

Comparatively few locomotives of the articulated type have been ordered during the past year. There appear several reasons for this: First, those companies that have physical conditions which can best be met by the use of the large Mallets have already a sufficient number in service for their requirements. Second, the increased ca-

capacity of the Mikado type made possible by the application of a stoker and superheater. Third, the revival of the Santa Fe type, also made possible by the stoker. Fourth, the general spirit of conservatism that has marked the whole locomotive situation during the year.

The Mallets ordered are all of the compound cylinder arrangement. Experience with simple Mallets has not led to any extension of this arrangement.

An articulated locomotive of very unique arrangement is being designed by the Baldwin Locomotive Works for the Erie Railroad. This locomotive will be of the 2-8-8-8-2 type, having three pairs of equal size cylinders, each being 36 in. in diameter by 32 in. stroke. The first two pairs of cylinders will be located and arranged in much the same manner as an ordinary Mallet type locomotive. The third pair of cylinders will be placed under the front end of the tender frame and will connect to four pairs of drivers under the tender. The trailer truck is also to be under the tender. The arrangement provides for compounding at the ratio of 2 to 1, and the center pair of cylinders is to use high pressure steam. One high pressure cylinder will exhaust to a receiver pipe which supplies the steam for two other cylinders. The right one, for instance, will supply the two cylinders under the tender and the left one the two cylinders at the front end of the locomotive. The exhaust from the cylinders under the

## Synopsis.

*Introductory.*

*Few Mallet Locomotives Built.*

*Economy and Capacity.*

*Standardization.*

*Boilers Better Proportioned.*

*Larger Cylinders.*

*Valve Gear.*

*Use of Alloy Steels.*

*Improvement of Minor Parts.*

*Mechanical Stokers.*

*Few Compounds Built.*

*Pennsylvania Atlantic Type.*

*Powerful Consolidation.*

*Assistance of Supply Companies.*

tender is to heat the water in the tank and such surplus as is not required for that purpose will be discharged to the atmosphere. Exhaust from the cylinders at the front end will probably be used to furnish the draft.

This locomotive is to have as large a boiler as can be applied within the clearance limits and the preliminary design provides for a tractive effort of about 160,000 lbs. working compound. The total weight of the engine will be in the neighborhood of 800,000 lbs. These locomotives, if finally built, will, of course, far exceed in weight and size anything that has heretofore been constructed.

#### ECONOMY AND CAPACITY.

Each year sees a more careful analysis of the service that the locomotives are to perform before the design is actually outlined and, while, so far, it has seemed advisable to design and build locomotives for the heaviest class of service on the road and to relegate the older power to the lighter service, a movement is beginning which will lead to the building of lighter locomotives suited for a particular class of service on branch lines or on certain divisions. The beginning of this movement is seen in the application of superheaters to lighter power as it goes through the shops for general repairs, and the improvement of the valve gears and the installation of brick arches. It is probable that within the next year or so orders will be given for lighter locomotives which will have the benefit of the more advanced knowledge of design and arrangement, and thus will give the economy which is now obtained only from the newer and most powerful locomotives on the road.

In fact, the past four or five years have been devoted almost entirely to obtaining increased capacity. Advances in economical features, which have been so numerous, have all been applied to this end. The demands in this direction seem to be now pretty well taken care of and attention is beginning to be given to greater economy for the saving it gives, which means the same amount of power now obtained, if that is all that is needed or desired for the service, with a distinctly reduced fuel consumption and weight of locomotive.

The new Atlantic type locomotive on the Pennsylvania, which is the most notable locomotive design of the year, is an indirect example of this, since it performs better service with a smaller consumption of fuel than a Pacific type which weighs about 60,000 lbs. more. Some recent consolidations, where they have been designed to do and are doing the work that has previously required the 2-8-2 type, are also examples of the same tendency.

There has been, recently, a very general movement on all the more progressive roads to improve the older locomotives, so far as possible, and bring them up to nearly the state of efficiency and capacity possessed by the more recent designs. This is probably best marked by the many applications of superheaters to old locomotives as they pass through the shop for general repairs. This same movement has begun with stokers on the larger capacity locomotives. When superheaters are applied it is not infrequent to apply a new valve gear and to enlarge the cylinders somewhat.

This idea, in some cases, is even carried to a greater extent and consolidation locomotives are being entirely rebuilt and changed to the Mikado type. The most prominent example of this action has been on the New York Central, where a total of about 150 locomotives have been altered from 2-8-0 to the 2-8-2 type. The result has been an increase of fully 33 per cent. in the capacity of the locomotive which has been obtained at a very reasonable cost.

#### STANDARDIZATION.

Extension of the practice of standardizing many parts of the locomotive, particularly those requiring frequent repairs or renewal, is general. Even the practice of standardizing whole locomotives so as to greatly reduce the number of classes in service, with an accompanying large improvement in the maintenance account and in the conditions of operation, is found on the more progressive roads.

H. H. Vaughan, assistant to the vice-president, Canadian Pacific, indicated the advantages of fully standardized locomotives at a meeting of the American Society of Mechanical Engineers to be: Standard locomotives can be transferred from one part of the road to another without a large storehouse stock; continued construction of the same locomotives reduces the cost of building as well as of the later repairs; it is possible to effect desirable variations in design much better than can be done when classes differ. It was also pointed out that the time for standardization is before the locomotives are built and not after they are running.

There has not been so great a tendency toward standard classes as appears in respect to standard parts. In a number of cases new locomotives have been built which required little more than a new design of boiler, frames and cylinders.

#### BOILERS ARE BETTER PROPORTIONED.

While each and every part of the locomotive has been subject to careful scrutiny and decided improvement, the boiler has been the point of most searching investigation and greatest advance. The goal of boiler designers is to obtain the largest number of pounds of steam to each pound of metal in the boiler. The various studies and experiments have clearly indicated the advantage of the use of a longer flamework between the fuel bed and the end of the tubes, giving an opportunity for completing the gas reaction before the products of combustion enter the flues.

Experiments on the locomotive testing plant at Altoona as reported to the Master Mechanics' Association show that boilers with short tubes have a distinct advantage in increased activity of combustion and in the rapidity of evaporation, or free steaming, but at the same time they also have a slightly lower efficiency since they absorb less of the total heat available during the passage of the gases through the tubes. It thus seems that the most desirable length of tube depends on how much one is willing to sacrifice in boiler efficiency to obtain rapid evaporation with some loss of heat. Experiments indicated that the rate of evaporation increased as the tube is shortened until it reached a maximum at a length between 12½ ft. and 14 ft.; after that it decreased rapidly. This information, taken in conjunction with the results of the experiments made at Coatesville in June, 1912, showing the comparative value of firebox heating surface and tube heating surface have had a noticeable affect already in increasing the use of combustion chambers with shorter flues.

The Pennsylvania has adopted a length of 15 ft. for 2 in. flues and a length of 19 ft. for 2¼ in. flues.

Speaking on this subject before the American Society of Mechanical Engineers, F. F. Gaines, superintendent of motive power of the Central of Georgia, stated that: "The most radical improvement that can be made on locomotives, and one which will be rapidly developed, is the use of greater firebox volume and heating surface. This is readily obtained by using a suitable grate area and combustion chamber. In fact, from past experience it would not be surprising if ultimately a flue length of 16 ft. would become a desirable maximum and the combustion chamber be substituted for the remaining distance." Experiments that have been made by Mr. Gaines with a type of combustion chamber developed by him indicate the truth of his assertion.

While no distinct movement toward reducing flue length to 16 ft. can be discovered, there is a noticeable tendency to increase the firebox heating surface, and this is being done both by the addition of a circular combustion chamber and, where possible, by the use of a firebox arranged on the Gaines principle.

Brick arches, supported on arch tubes, are now in very general use on all classes of locomotives. An appreciation of the value of the heating surface in the arch tubes is becoming more apparent and the objections that had previously been made to them seem to have been entirely overcome.

Openings for the admission of air into the ash pan and through the grate are, in a few instances, being given the attention they

deserve, and in recent designs, which follow the best practice, as large an air inlet as possible is given. The opening should be 50 per cent. of the grate area, or more, if possible, on road engines. More study should be given this most important subject, and it is probable that the most marked advance in locomotive operation in the coming year will be along the lines of securing more perfect combustion.

Experiments with a powerful passenger locomotive on the Altoona testing plant early in the year indicated the importance of further study of the nozzle, stack and cylinder passages. This has already had its effect and the present practice is to place the nozzle as low as it is possible to get it. Where the boiler is large in diameter, the internal extension of the stack is universally used in order to obtain the required length. The use of nozzle tips in shapes other than round has shown a distinct improvement in the exhausting of locomotives under certain conditions. It appears that by the proper selection of the shape of the nozzle tip and the use of tips other than round are of great value in compensation for a poor arrangement of exhaust passages which in some cases is unavoidable on account of the lack of room. These nozzles in some instances have shown a surprising reduction in the coal consumption and an increase in power in the cylinders.

The study given to this feature has also led to a better design of the exhaust passage in the cylinder itself, with a still further reduction in the back pressure.

At the Traveling Engineers' Convention, in the discussion of the report on operating superheater locomotives, it appeared that the best practice, in the opinion of those discussing the paper, was to use a full throttle opening up to the point where the cut-off was 25 per cent., and if a longer cut-off than this is necessary the throttle should be partially closed in preference to lengthening the cut-off. This, of course, means larger diameter cylinders if the full power of the locomotive is to be developed.

Larger cylinders, if they were to be used with late cut-offs, would imply the necessity of larger steam and exhaust ports, and thus larger piston valves. Since, however, they are being used entirely with the idea of using the short cut-off and the period of admission of the steam is at a time when the piston is moving slowly, there has been no noticeable movement toward larger valves. In fact, the tendency is more toward an improvement in the valve gear to give a larger port opening for both admission and exhaust, which allows the use of even a smaller diameter of valve. On one road the 12 in. diameter piston valve is being used with superheated steam on practically all sizes of cylinders, and no trouble is found in holding up the steam pressure during the first 30 per cent. of the stroke. While 16 in. diameter piston valves have been used in a few cases, the general tendency is toward a smaller diameter and a more careful design of the valve gear.

On the Norfolk & Western, the Hobart-Allfree cylinders which provide an auxiliary exhaust opening and a reduced back pres-

TYPICAL MIKADO TYPE LOCOMOTIVES BUILT DURING 1913.

Design No.	Weight in Pounds.					Cylinders Diam. and Stroke, in.	Diam. Drivers, in.	Steam pressure, lb.	Tractive Effort, lb.	Grate Area, sq. ft.	Heating Surface.			Superheater, sq. ft.	Tender.		Wheelbase.	
	Truck.	Drivers.	Average per axle.	Trailer.	Total.						Tubes, sq. ft.	Firebox, sq. ft.	Total, sq. ft.		Coal (tons).	Water (gal.).	Driving, ft. and in.	Engine, ft. and in.
1.....	27,500	245,000	61,250	49,500	322,000	27x30	63	190	56,100	59.6	4,494	218	4,740	1,084	12	7,500	16-6	36-1
2.....	30,500	240,500	60,125	49,000	320,000	28x30	63	180	57,200	70.4	3,266	290	3,591	846	16	10,000	16-6	35-3
3.....	29,000	238,200	59,550	52,100	319,300	28x30	63	180	56,500	63.0	4,017	230	4,276	898	16	9,000	17-0	35-2
4.....	37,600	228,200	57,050	52,600	318,400	27x30	62	190	56,000	62.0	4,547	274	4,821	1,101	12.5	8,000	16-6	35-2
5.....	28,000	233,500	58,375	45,500	307,000	28x30	63	185	58,700	57.1	4,095	224	4,339	953	15	8,500	16-6	34-11
6.....	28,000	227,500	56,875	46,500	302,000	27x32	61	170	55,300	63.1	3,939	230	4,198.6	890	13.3	8,275	17-6	36-5
7.....	27,000	214,500	53,625	46,000	287,500	26½x30	61	185	54,500	57.5	3,379	227	3,634	831	14	8,500	16-6	35-1
8.....	26,000	213,500	53,375	43,500	283,000	27x30	63	175	51,700	56.5	3,397.8	214.8	3,639.3	757.3	15	9,000	16-6	35-1
9.....	24,600	213,200	53,300	44,000	213,200	26x28	63	200	51,000	71.5	3,972	242	4,214	890	15	9,000	16-6	35-2
10.....	23,700	201,700	50,425	32,400	257,800	23½x32	63	180	42,900	49.3	3,403.4	200.3	3,603.7	566	16	7,000	16-6	35-5

Various arrangements of blowers or suction fans for giving the required draft through the tubes have not passed beyond the experimental stage, and there has been no evidence presented as to what practical advantages such an arrangement might have.

Circulation throughout the whole boiler is being improved as the effect of improper flue spacing, narrow passages and trapping of water near hot sheets is better understood. The value of the arch tubes as circulation improvers is but beginning to be appreciated.

LARGER CYLINDERS.

One of the changes in proportions which has been found advisable in order to obtain the full advantage of superheated steam, is the use of larger cylinders. At first this was accompanied by a reduction in the steam pressure and the increased size of the cylinders was simply to obtain the full power with the lower pressure. Lately, however, a tendency is noted toward using larger cylinders, even with the high pressures, and some of the more recent designs would, at first sight, seem to be considerably over-cylindered. Here again it is the results from the Altoona locomotive testing plant that have pointed to the best practice. The conclusions reported to the Master Mechanics' Association of tests on Atlantic and Pacific type locomotives stated that for maximum economy with superheated steam the maximum indicated horsepower should be developed at a cut-off not exceeding 30 per cent.

sure are being used on all new simple locomotives and are being applied to the older power as it requires new cylinders.

VALVE GEAR.

While the Walschaert type of valve gear is used on a very large majority of the locomotives, including all types, the Baker valve gear has been applied in a number of cases and at the present time there are about 2,000 locomotives operating in the country with this type of gear. New arrangements of valve gear seem to be attracting the attention of designers, and two or three original constructions have appeared during the year but, so far, are only in experimental service.

The improvements in the Walschaert gear have all been along the lines of the use of better materials and thus of lighter parts, and the more rigid support of the valve-stem crosshead. The screw reverse gear has met with quite general favor and is being applied to many of the larger types of simple locomotives. On Mallet engines and some of the very large examples of the Mikado and Santa Fe types, power reverse gears have also been applied. A screw reverse was applied to some switching locomotives on the Illinois Central early in the year, and it is reported to be a satisfactory arrangement for this service when compared with the usual hand-operated lever arrangement.

On the Philadelphia & Reading a new arrangement of reverse gear which combines both the screw and lever designs was applied to an inspection locomotive. With this construction the complete reversal of the engine can be made promptly by means



of the lever in the ordinary manner and the adjustments of cut-off are made by the screw.

USE OF ALLOY STEELS.

Alloy steels are being more widely used for many of the locomotive parts. In most cases the heat-treated steel is employed and very excellent results are reported. In a few cases a considerable reduction of section and of weight has followed the use of this improved material. More generally, however, the greater strength has been used for the purpose of reducing the unit fiber stress and thus increasing the reliability of the parts. The Pennsylvania allows 25 per cent. higher stress in piston rods and pistons when heat treated steel is used. This followed tests which showed the elastic limit of the material employed to be 50 per cent. greater than the non-treated steel.

The alloy most generally employed has been a chrome vanadium. The number of parts of this material applied during the year to locomotives is given in the following table:

	Number of Engines.	Number of Parts.
Axles .....	466	1,277
Crank pins .....	188	580
Piston rods .....	69	138
Main rods .....	347	734
Side rods .....	354	1,840
Springs (engine and tender).....	306	
Frames .....	776	1,592
Engine truck axles.....	62	62
Wheels .....		700
Tires .....		1,000

Important improvements have been made in the connection between locomotive and tender, allowing greater freedom of relative movement without the presence of any lost motion.

There is no general tendency noticed in respect to any important changes in the tender. The sizes remain about the same as the last two or three years, and a capacity for 7,500 to 8,000 gals. of water and 13 to 14 tons of coal is normal for the modern heavy locomotive. Coal pushers have been applied in some cases, and materially assist the fireman. New designs of tender truck have appeared on some roads, which usually are intended to increase the strength and better riding qualities. The Santa Fe has applied some six-wheel trucks to tenders for passenger locomotives but, so far, is alone in this practice.

STOKERS.

During the past year the service of the stokers previously applied and of the large number placed in service during the year, prove that this device has passed the experimental stage. Thus, after 25 or 30 years of experiment, the stoker has reached the position of reliability and serviceability which allows it to be accepted with confidence for use on the larger sizes of locomotives. This is probably as important a development as has occurred this year since it removes one of the greatest limitations in the way of further increase in the size of locomotives. The service results of the stoker indicate that the capacity of the locomotive as to maximum tonnage and speed will be increased by it in

TYPICAL PACIFIC TYPE LOCOMOTIVES BUILT DURING 1913.

Design No.	Weight in pounds.					Cylinders, Diam. and Stroke, in.	Diam. Drivers, in.	Heating surface.					Tender.		Wheelbase.			
	Truck.	Drivers.	Average Per axle.	Trailer.	Total.			Steam Pressure, lb.	Tractive Effort, lb.	Grate Area, sq. ft.	Tubes, sq. ft.	Firebox, sq. ft.	Total, sq. ft.	Superheater, sq. ft.	Coal (tons).	Water (gal.).	Driving ft. and in.	Engine, ft. and in.
1.....	46,100	189,500	63,167	57,600	293,200	26x26	80	205	38,000	55.4	3,453	204	3,680	845	17.3	8,000	13-10	35-2 1/2
2.....	46,500	185,500	61,833	56,000	288,000	25x28	73	200	40,500	94.8	3,579	239	3,857	821	10	9,000	13-0	34-10
3.....	47,500	186,500	62,167	50,000	284,000	25x28	69	200	43,100	58.0	3,727.6	199	3,954	867.8	14	8,000	13-0	33-10
4.....	51,300	179,900	59,967	50,800	282,000	27x28	73	185	43,500	59.6	3,535	220	3,786	879	14	8,000	13-0	34-1
5.....	53,000	174,500	58,167	54,000	281,500	25 1/2 x 28	73	190	40,250	63.0	3,259.4	212.8	3,497.6	805	14	8,500	13-0	33-10
6.....	56,400	164,100	54,700	51,200	271,700	17 1/2 x 29 x 28	73	210	34,000	57.6	3,233	181	3,444	619	12	9,000	13-8	35-1
7.....	50,000	172,000	57,333	49,000	271,000	23 1/2 x 26	79	200	30,900	56.5	3,192.9	204	3,424	774	12	7,500	14-0	36-6
8.....	49,600	165,500	55,167	44,700	259,800	25x28	72	180	37,000	66.7	3,553	241	3,823	842	14	8,500	13-0	34-1
9.....	49,000	154,000	51,333	48,500	251,500	24x28	73	200	37,600	53.2	3,092	188	3,309.3	780	13	6,000	14-1	34-5 1/2
10.....	49,300	159,200	53,067	40,100	248,600	24x28	76	185	33,500	56.5	2,359	185	2,567	587	16	7,000	13-2	34-3 1/2

The frames are simply annealed, but all other parts are heat-treated.

IMPROVEMENT OF MINOR PARTS.

Improvements of many of the minor details tending toward a greater reliability, reduction of cost of repairs or increased convenience have been general. Steam pipes extending through the front end and connecting to the top of the steam chest are used in a majority of cases, thus reducing the weight of the cylinder castings and improving the steam passages and the quality of the steam. Driving boxes with a length of bearing on the journal much greater than in past practice have been developed by the American Locomotive Company and applied to a large number of heavy passenger locomotives. Pressed steel is being used for bumper beams and for the pilot in place of wood on many of the recent locomotives. Improved arrangements for holding the piping have been developed on the Lake Shore and have drawn attention to the necessity for better construction in this particular, which is having its effect on some of the recent locomotives. The addition of graphite to the oil for the lubrication of cylinders is reported as being very successful on superheater locomotives in a number of cases. Air operated fire doors in several designs are being applied to the heavier types of freight locomotives and to some of the large passenger engines. A vestibule type of cab has been designed by the Canadian Pacific and is being applied to most of the new locomotives on that road.

much the same way as has occurred by the application of the superheater.

The overfeed or scatter type stoker is the more popular, although applications of the underfeed or Crawford design continue to be made, principally by the Pennsylvania Lines West of Pittsburgh.

Experience with stokers in comparatively large numbers on a single division or on a single road show that the cost of maintenance is low. The reports do not indicate, however, that there is any noticeable saving in coal by the use of stokers, but there is a considerable increase in the capacity of the locomotive in practically every case. Further advantage, particularly in connection with the underfeed design, is the elimination of the smoke which makes it of especial value for use on switching locomotives.

The Street stoker has received the widest application, and is now in use on 13 railroads which together have 365 stokers in regular operation and 69 on order. Reports from one of the roads using a large number of these stokers show that the maintenance is less than .5 cents a locomotive mile. In another case where there are 85 Street stokers in operation the reports show 50,000 locomotive miles for each stoker delay of any character. There are 293 Crawford underfeed stokers in use. This type is showing a satisfactory service both in reliability and cost of maintenance.

In addition to above mentioned designs there is a single stoker of the Hanna type in use on the Carolina, Clinchfield & Ohio

which has been in service for over three years. About three months ago an improved design of Hanna stoker was installed on the same road. Both machines are now operating with complete satisfaction.

Two new designs of stokers have appeared during the year, both being of the overfeed or scatter type. These are the Standard stoker which is now undergoing tests on the New York Central Lines, and the Gee stoker, which is in experimental use on the Pennsylvania. Experience with the former covering six months has led to the decision to make further experimental applications and it is now being applied to a 2-6-6-2 type locomotive.

In general the effect of the success of stokers has been a relief from the handicap of having to consider the stoking capacity of the fireman on very large locomotive units, a tendency to somewhat enlarge the size of cylinders on moderately large units and an increase in the tonnage rating of stoker locomotives due to the assurance of full steam pressure throughout the length of the run. In addition to the economies offered by improved operating conditions, a material saving in the cost of fuel has been obtained in a number of cases because of the ability to use a poorer and lower priced quality of coal with stokers.

Stokers have so far been applied almost entirely to freight locomotives, since it is here that the increased capacity is particularly desired. It is also in freight service that the fatigue of the firemen at the end of a long run is most noticeable in its effect on the capacity of the engine.

responsible for this remarkably successful service. Boiler capacity, of course, is the absolutely essential feature for sustained power at high speeds, and these engines exceed all previous attempts for a two coupled locomotive in this respect. The powerful boiler necessarily means heavy weight, and here again have the records been broken. The weight on each of the drivers approximates 67,000 lbs., and the total weight of the locomotive is 240,000 lbs.

This apparently excessive weight on drivers is permitted because the dynamic augment due to the counterbalance at a speed of 70 miles an hour is less than 30 per cent. of the static weight on drivers. As a result these locomotives do not deliver as heavy a blow on the rail nor do they have as bad an effect on the track, so far as strain is concerned, as the majority of passenger locomotives which have a weight on drivers from 10,000 to 12,000 lbs. less per axle.

This result has been obtained only by the utmost care in the design of the reciprocating parts to obtain the minimum weight with the great strength required by the amount of power that is transmitted by a 23½-in. diameter cylinder with 205-lb. steam pressure. What has been accomplished in this respect is probably best illustrated by a statement of the weights of the various reciprocating parts of this locomotive. The 23½-in. diameter piston with piston rod key and shoe complete weighs 408½ lbs. The crosshead and wrist pin complete weigh 312 lbs., and the crosshead end of the main rod weighs 279½ lbs. This gives a total of 1,000 lbs. weight of reciprocating parts on each side of

TYPICAL CONSOLIDATION LOCOMOTIVES BUILT DURING 1913.

Design No.	Weight in Pounds.				Cylinders, Diam. and Stroke, in.	Diam. Drivers, in.	Steam pressure, lb.	Tractive Effort, lb.	Grate Area, sq. ft.	Heating Surface.			Tender.		Wheelbase.		
	Truck.	Drivers.	Average per axle.	Total.						Tubes, sq. ft.	Firebox, sq. ft.	Total, sq. ft.	Superheater, sq. ft.	Coal (tons).	Water (gal.).	Driving, ft. and in.	Engine, ft. and in.
1.....	30,500	236,000	59,000	266,500	26x30	57	185	55,900	66.75	3,293.4	223.7	3,517.1	774	15	9,000	17-0	27-0
2.....	25,500	230,500	57,625	256,000	25x30	57	185	51,750	99.85	2,072.1	256.6	3,098.2	622.5	14	9,000	17-0	26-1
3.....	30,000	224,000	56,000	254,000	26x30	56	175	53,900	62.5	1,986	198.2	3,026.6	695.7	17	9,000	17-0	26-10
4.....	24,940	186,060	46,513	211,000	24x30	61	180	43,000	53.4	2,185	178.0	2,392.0	522	12	7,300	17-0	26-0

FEW COMPOUNDS BUILT.

Except on articulated types of locomotives, there appears no inclination to use compound cylinders. A very noticeable exception to this general opinion is found on the Atchison, Topeka & Santa Fe, where balanced compound Pacific type passenger locomotives continue to be built. This company has had a long and extensive experience with balanced compound locomotives of the Atlantic, Prairie, and Pacific types for passenger service, the earlier ones being with saturated steam and the later additions of the Pacific type having superheaters.

PENNSYLVANIA ATLANTIC TYPE.

Because of its exceptional facilities for obtaining accurate information on the effect of the various detail features of design, and a broad-minded policy of the management in respect to the activities of the motive power department, it is not surprising that it is on the Pennsylvania Railroad that the greatest progress and most advanced position in locomotive design is found. This is well illustrated by the design of Atlantic type locomotive that has been perfected by this company during the past year.

This locomotive, on one district of the road which includes a very heavy grade, is pulling trains containing six all-steel passenger coaches, while a powerful Pacific type that has a total weight of 60,000 lbs. more than the Atlantic is able to handle but five cars on the same schedule. Furthermore, the same class of locomotive is successfully pulling trains of thirteen steel cars weighing up to 984 tons, between Manhattan Transfer, N. J., and Philadelphia, Pa., on schedules which require a sustained speed of 60 miles an hour for long distances.

No one feature of the design can be held as being principally

the locomotive. The same care and refinement was also given to the valve and gear and the main valve, which is a hollow inside admission 12 in. piston type, weighs but 119 lbs. The valve stem crosshead and pin weigh but 43½ lbs., and the lap and lead lever 39½ lbs.

Success in the effort to obtain the minimum weight of these parts is due to two things. First, the most careful analysis of the stresses and a determination of the best form of construction to properly transmit them. Second, the use of the very best quality of heat treated steel where it possessed any advantage. The piston heads are drop forgings and are Z shape in section. The piston rods are hollow and are of the very best quality of material, heat treated. The main and side rods are also heat treated steel, and the steel casting forming the crosshead is remarkably small and light.

After the very low percentage of dynamic effect of the counterbalance, probably the next most important feature of the design and one which is unique for this type of locomotive is the method of equalization, whereby the four-wheeled front engine truck is equalized with the front pair of drivers and the back pair of drivers are equalized with the trailer truck only. It is believed that this is the first instance of equalizing an Atlantic type locomotive in this manner and the result has been highly satisfactory.

The design of the boiler is as interesting as the other features and is based on the principles that have been developed by the work on the locomotive testing plant. No attempt can be made here to give a full description of the boiler, and it is sufficient to state that it is of the Belpaire type which is standard on the Pennsylvania, has an outside diameter of 78½ in. at the front

end and 2-in. flues 15 ft. in length. The grate area is slightly in excess of 55 sq. ft., and a 36-unit Schmidt design superheater has been applied.

The advantages of the screw reverse gear are indicated by the fact that it has been used on this locomotive where the weight of the valve gear and parts is very light and it is not actually required on that account.

Some of the general dimensions of the class of locomotives of this type now being built are as follows:

Tractive effort .....	29,427 lb.
Total weight .....	240,000 lb.
Weight on drivers .....	133,100 lb.
Weight on leading truck .....	55,000 lb.
Weight on trailing truck .....	51,900 lb.
Weight of engine and tender in working order .....	398,000 lb.
Wheel base, driving .....	7 ft. 5 in.
Wheel base, total .....	29 ft. 7 1/2 in.
Wheel base, engine and tender .....	63 ft. 10 1/2 in.
Diameter of driving wheels .....	80 in.
Diameter engine truck wheels .....	36 in.
Diameter tender truck wheels .....	36 in.
Cylinders, diam. and stroke .....	23 1/2 x 26 in.
Diameter piston valve .....	12 in.
Valve travel .....	7 in.
Steam lap .....	1 5/16 in.
Lead .....	205 lb.
Steam pressure .....	78 1/2 in.
Outside diameter, front ring of boiler .....	72 in. x 110 1/4 in.
Firebox, length and width .....	242—2 in.
Tubes, number and outside diam. .....	36—5 3/4 in.
Flues, number and outside diam. .....	180 in.
Tubes and flues, length .....	2,660.5 sq. ft.
Heating surface, tubes .....	195.7 sq. ft.
Heating surface, firebox .....	721 sq. ft.
Superheater heating surface .....	2,856.2 sq. ft.
Heating surface, total .....	55.13 sq. ft.
Grate area .....	7,000 gal.
Tender, water capacity .....	13 tons
Tender, coal capacity .....	

**POWERFUL CONSOLIDATION.**

Another interesting locomotive design which typifies the present progress is a consolidation type for the Wheeling & Lake Erie, designed and built by the American Locomotive Company. This design illustrates what can be accomplished with some of the older types of locomotives. It was only about a year ago that the general opinion prevailed that the consolidation type was at the point of becoming obsolete for new locomotives, and that the Mikado would entirely replace it. There were good grounds for this impression for, with the exception of the Pennsylvania, no road had made any important improvement in this type for over ten years. This locomotive, however, proves the fallacy of the conclusion, and within the speed limits of a 57-in. diameter driver it has distinct advantages over a Mikado type. It delivers a pound of maximum tractive effort for each 4.77 lbs. total weight of locomotive, and gives one square foot of equivalent heating surface for each 57 lbs. total weight of locomotive. It was fully illustrated in the December issue of the *Railway Age Gazette, Mechanical Edition*, page 641.

In this connection it is interesting to note that the consolidation type locomotive is being more generally used in all sizes than was the case a couple of years ago. In the present year the total orders for this type exceeded 700, while the orders for Mikado locomotives were somewhat less. There were about 435 locomotives of the 2-8-0 type ordered by the Pennsylvania alone during the year.

**ASSISTANCE OF THE SUPPLY COMPANIES.**

Credit should be given to various railway supply companies, locomotive builders and other auxiliary activities for developing original improvements and the energy put forth in co-operation with the railway companies in bringing locomotives to the highest state of efficiency. Many of the most important and valuable appliances which are now in universal use, would beyond doubt, have languished for many years had it not been for the interest and energy of supply companies in rapidly developing them to a state of perfection. The superheater, brick arch and stoker are prominent examples. Under the present organization of the motive power departments on many railroads, there is little opportunity for initiative or experiments, and the work of the locomotive builders and supply companies has been of very great importance and value in bringing the American locomotive to its present position.

**PASSENGER CONDITIONS AND THEIR RELATION TO THE PUBLIC.\***

By GEORGE W. BOYD,

Passenger Traffic Manager, Pennsylvania Railroad.

The business of transporting passengers by railroad is scarcely 80 years old. The primitive methods of making rates, as well as of handling the passengers, were inherited by the railroads from the stage coach and the canal boat, and it is by no means improbable that the crudity of such a system, coupled with the common prejudice of the people against the newly found means of locomotion, produced the first feeling of antipathy on the part of the public against railroad management.

For nearly 50 years what may be termed the creative period of railroad history continued, and during that period the administration of passenger matters, in the absence of system and the lack of concerted action, was in a chaotic condition. The construction of new lines and the extension of those in existence made competition rampant. The struggle for traffic brought out a multitude of abuses in the devious practices resorted to for the control of traffic. The commission system bloomed and flourished, the scalper became an active force for evil, and rate wars budded and broke out over night. The passenger man's lot was not a happy one. He was a public enemy unless he yielded to popular clamor. He had to keep a sleepless eye on his competitors to protect his traffic and present a brave front to his own executive superiors, who in those days had scant sympathy with the passenger movement and rather considered the passenger department in the nature of a disordered appendix.

To continue this savage strife was fatal to all hope of profit, destructive of business integrity and inimical to the rights of shareholders. A great light broke upon the passenger situation, and a finer feeling of fair dealing and honest practices was born. The payment of commissions to agents for the control of traffic was discontinued and gradually eliminated from the situation. The law was invoked to drive the scalper from the field, and the fight against this pernicious enemy of honest dealing was relentlessly waged and won in state after state until he was practically driven from the field.

A surer and more equitable basis of rate-making and a firmer stand in their maintenance followed these reforms as a natural result. Intercourse between passenger men became more candid and sincere, a higher standard of integrity became the ruling spirit in passenger affairs, and the administration of passenger business in all its complex details assumed a place in railroad affairs which not only increased the earning power of passenger transportation, but elevated the passenger branch of the traffic department in importance, dignity and influence.

As we look back now on the record of passenger history in the last 25 years it seems clear that the leaders of the reform movement in the conduct of passenger business were unconscious forecasters of coming events. They were wisely strengthening their lines and concentrating their forces in preparation for the new conditions which national and state legislation was bound to force upon them.

It counted for nothing that during years of honest and continuing endeavor the passenger officials had striven to so regulate their business as to give the public, without favor or preference, the benefits and advantages of equitable and fair rates and superior passenger service. That old and lingering prejudice against railroad interests had waxed stronger in the public mind and reached a point of such intense and widespread hostility as to demand of the national lawmakers restrictive and regulative legislation against the railroads. This widespread sentiment took shape and form in the first interstate commerce act, creating the Interstate Commerce Commission, which undertook to regulate the conduct of all railroad business in its relations to the public. On account of the conservative measures which had

\*Abstract of an address before the American Association of General Passenger and Ticket Agents at Philadelphia, October 14, 1913.

been put in practice in the 10 years preceding the enactment of this law, the majority of the railroads were prepared to adopt its provisions without serious interference to their revenues. The abolition of passes, in fact, tended to increase earnings, and the anti-discriminatory features of the bill served to still further strengthen the integrity of the rate situation and uphold the policy of a fair deal to all the people. The significant fact that very few prosecutions have been instituted for the infraction of the national laws against passenger traffic officials is ample proof that passenger men are law-abiding citizens and ever ready and anxious to perform the obligations of the railroad to the public to the fullest extent.

The Interstate Commerce Commission has practically taken over the rate-making duty of the railroads. Its powers in this respect are more than regulative—they are mandatory. Interstate rates are required to be fixed on certain principles prescribed by the law, and the commission is constantly on the alert to see that the requirements of the law are strictly observed. Rate making, therefore, has its legal status. It cannot be juggled to the advantage of one line over another. The will of the people, as expressed through their representatives, is paramount. The people have tied up the transportation lines, and force them to sell their product at a price that the purchaser determines. It is an anomalous situation. Ordinarily, the law of supply and demand fixes the price of a commodity, but railroad transportation is sold to the people at what they think the price should be without regard to the cost of production. The glaring inconsistency and manifest unfairness in this situation places the transportation lines at the enormous disadvantage of having the price of their product definitely fixed by an overruling power without the aid or authority from this power to regulate or control the expense of producing it. The law says you shall not charge any more than a fixed maximum rate for transporting passengers, but it does nothing to help you in fixing a reasonable scale of wages for the workmen required to perform the service you must render to the public. As far as the established rate regulation is concerned, it is, therefore, a one-sided affair, with all the odds against the railroads.

There can be no question of the wisdom of a governmental regulation of passenger rates under wise and well-considered legislation. It undoubtedly helps the railroads to escape those abuses against which they fought for so many years before the law took an active hand in the matter. But the public, for whose benefit all the regulative legislation is designed, fail to appreciate that they have the railroads backed into a corner, hemmed in on the front by the law and on the flanks by the insistent and extravagant demands of labor.

It should be remembered that national legislation is not the only restrictive force that confronts the railroads in their operation. Every law-making body in the country, from the tiny borough council to the halls of Congress, is active in the general movement. Every ruling or enactment of each one of these bodies in respect to the railroads affects the earning power of the railroad by increasing its expenses. Uncomputed millions of dollars within the last decade have been added to the cost of performing transportation by the innumerable laws imposed upon the railroads by the people.

All these multiplied forms of added expense have a direct bearing on the capacity of the roads for performing adequate passenger service. It follows as a natural consequence that, if passenger operation cannot be counted on to supply its proper proportion of revenue on account of the low rates enforced, the high standard of passenger service must be lowered. This would prove a most unfortunate hindrance to railroad progress. For 30 years, even during the period of rate instability, there has been a gradual but uninterrupted improvement in equipment and in the essential features of the passenger service in general. In response to the public demand, high grade trains, with accommodations not dreamed of a generation ago, have been introduced, multiplied and maintained in the highest state of efficiency. Years ago the appointments and speed of American

trains compelled the admiration of the world. At the present time they have reached the climax of superiority. All-steel cars of every class provide not only every requisite of comfort and convenience, but insure the maximum of comfort and safety. The modern locomotive, with its enormous power and possibilities of speed, makes regularity of movement the rule instead of the exception. Terminal stations, notable in architecture, lavish in spaciousness, convenient in accessibility, stand as convincing proof of the purpose of the railroads to give the public the perfection of service in every detail.

The transportation of person and property by railroad is the greatest business in the world. It touches more points of human activity than any other organized business. Its intimate relations with trade, commerce, the household, society in general, and the government make it the one indispensable factor of modern existence. With this vast multiplicity of connections with the vital affairs of life, it is necessary that its administration should demand the keenest tact and the wisest judgment. The record of passenger transportation proves that such characteristics are conspicuous in the administration of passenger affairs on our American railroads. The passenger officials of our railroads, as evidenced by the membership of this body, are able, broad and high-minded men, specialists in their profession by education and experience. Keenly alive to the responsibilities imposed upon them by the ethics of business and the requirements of the law, they are fully competent to serve their corporate masters with loyalty and the public with equity and justice. No passenger man wishes or tries to deprive the public of any of its rights. On the contrary, his aim is to interpret the law under which he works as liberally as possible, so that the people may enjoy the benefit of every advantage modern railway management can provide for them.

If the public could be convinced that the railroads are striving to give the service it demands, as far as possible within the law and under the burden of expense imposed by the law, it can hardly be doubted that sentiment in this regard would become more favorable to the corporate interests of the country. The American people in the end are always fair, and if they can be brought to realize that railroad management is honestly endeavoring to fulfil its obligations to the law of the land, and at the same time serve the best interests of the people, who are primarily responsible for the laws, they will be less eager for lower passenger fares when demanding improved passenger service. Thousands of these people are investors in railroad securities, and the promptings of their own self-interest must sooner or later influence them to give the railroads a square deal.

I feel assured that this association is of one mind in its desire to enlighten the public to a proper realization of its responsibility in these matters. Railroads cannot go on forever paying dividends if their earning power, already weakened by low rates, is to be still further eaten into by high wages, high taxes and the numberless other expenses that a compliance with the existing laws entails.

It is the plain duty of members of this body to bestir themselves jointly and individually, to use their best endeavors to educate the public mind to the importance of popular support and encouragement to railroads in order that the best interests of all concerned may be conserved.

By practice and precept, by speech and by writing, they can sow in the public mind the seeds of a better feeling toward railroad management. By a rigid adherence to the legally authorized rates they can prove to the public that everybody dealing with the railroads is on the same footing, and that no advantage is enjoyed by individual or organization.

By instilling into the minds of all employees the principles of efficiency, courtesy and consideration in all their dealings with the public they can make a long forward step toward winning and holding the confidence of the people.

With the popular distrust of the corporate interests turned into confidence, the active support of the people will undoubtedly be given to all well-managed railroads throughout the country.

# HIGH CANTILEVER BRIDGE IN MEXICO.

The National Railways of Mexico New Bridge Across Rio Chico. The Height of the Bridge Above the Water is 230 ft.

The National Railways of Mexico have recently completed a high steel cantilever bridge over the Rio Chico on a new line between Durango and Llano Grande. This line is located in the state of Durango, extending about 63 miles west from the

develop extensive pine timber resources, but it will also serve a mining and cattle country with some agricultural development.

The line crosses the Rio Chico, about 20 miles west of

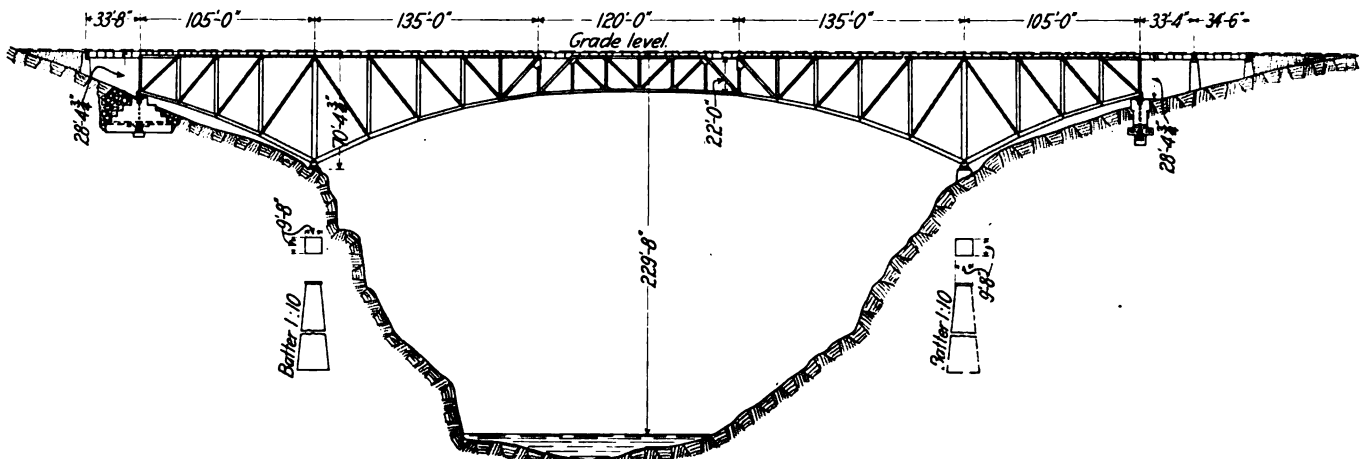

Elevation of Cantilever Bridge Over Rio Chico on the National Railways of Mexico.

city of Durango and forming a part of the located line to the port of Mazatlan on the west coast of Mexico at about latitude 23 deg. 10 min. This extension has been built principally to

Durango. At first it was planned to build a steel viaduct over this deep ravine, but as it was necessary to design for a loading equivalent to Cooper's E-60, the company's consulting engi-



Starting the Erection of the West Half of the Structure. Digitized by Google

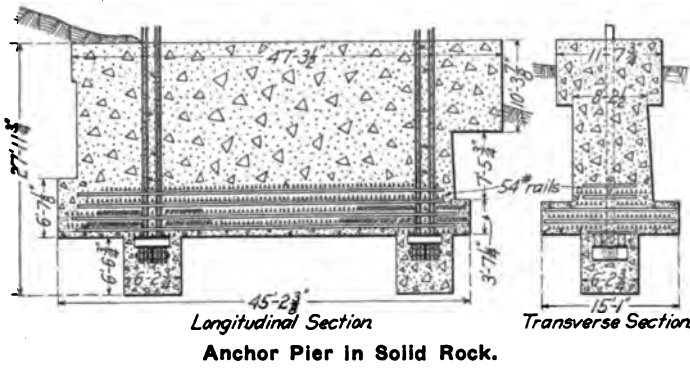

neers found that satisfactory stiffness could not be obtained in steel towers of the height required. The plan for a viaduct was therefore abandoned and a single track cantilever bridge adopted, having anchor arms of 105 ft., cantilever arms of 135 ft. and a suspended span of 120 ft. In addition to these main spans there are three deck plate girder spans 32 ft. 6 in. long in the approaches, making the total length of the bridge between back walls 701 ft. 6 in. The base of rail is 244 ft. 1 in. above the bottom of the barranca.

The anchor arms consist of four panels; two of 23 ft., one of 26 ft. 6 in., and one of 32 ft. 6 in. The spacing between trusses is 30 ft., the depth of truss at the rear anchor 28 ft. 4 3/4 in. from base of rail to top of masonry, and at the vertical

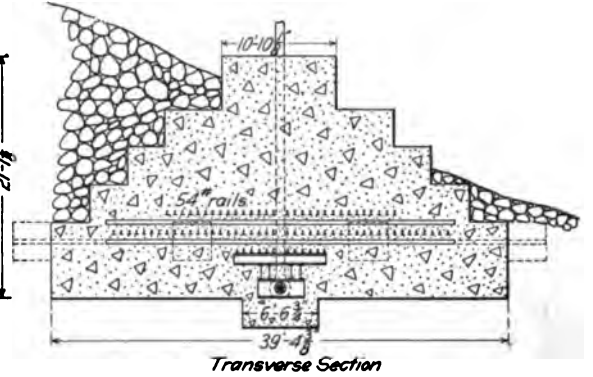
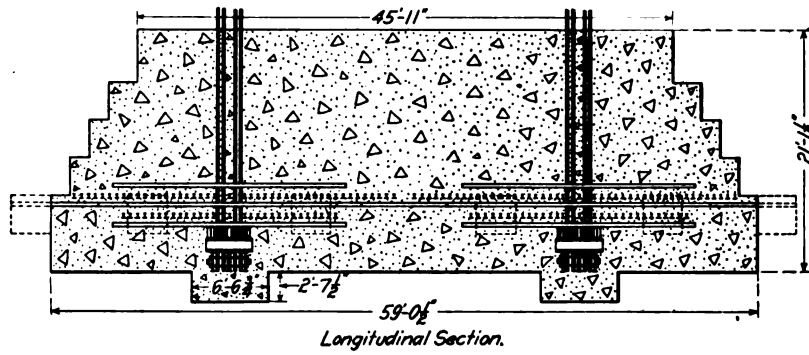

Anchor Pier Covered with Loose Rock.



Placing Last Section of Lower Chord.

post of the cantilever arm, 70 ft. 4¾ in. The anchors consist of concrete masses buried in the solid rock which forms the walls of the ravine. On the east side this concrete is placed in an irregular block with a collar from 2' to 3 ft. wide extending into the solid rock. Eight 10 in. x 1¾ in. "I" bars which connect the lower chord of the truss to the anchorage are carried down through grillages of 54-lb. rails to a pin supported by "I" beams on the under side of the rail grillages. The total section of these "I" bars is 140 sq. in., the safe load on which at 16,000 lbs. per sq. in., is 2,240,000 lbs. for each anchorage. The ultimate strength of the bars at 55,000 lbs. per sq. in., is 9,100,000 lbs. The weight of the east anchor is calculated as follows:

245 cu. yd. concrete.....	1,481,395 lbs.
1,884 lineal yd. of 54 lb. rail, including anchors.....	109,031 lbs.
108.5 cu. yd. material over collar.....	626,832 lbs.
1,735 sq. ft. of shearing surface.....	7,486,500 lbs.
<b>Total .....</b>	<b>9,703,758 lbs.</b>

The west anchor was designed to be built in much the same manner, but in undercutting the rock to place the concrete collar the finely seamed rock sheared off and it was necessary to increase the weight. After building the large block of concrete

with a 2 ft. camber in the lower chord. It has six spans of 20 ft. each.

The bridge was erected from the east end, all material being brought in at that end. The east anchor and cantilever arm were first put in place, these two sections being finished May 11, 1912. When this half had been completed, two 1¼ in. steel cables were swung from the upper main post pins of the east anchor up over a gallows frame built on the end of the erected steel to a "deadman" that was anchored in solid rock beyond the west abutment. A hoisting engine was installed on the end of the east cantilever arm and another one which was carried across on the cable was installed at the west end of the bridge, these two engines handling all the steel for the west side on this cableway. The steel was loaded on the east side with a derrick car, carried out to the gallows' frame and swung on the cables. It was picked from the cables by a traveler and swung into place. The traveler used on this work had a 50-ft. boom with 25 tons capacity on the last needle bar, and was equipped with a 30 h. p. Mundy erector's engine. The heaviest single piece placed with this traveler weighed about 30,000 lbs. Erection was started on the



The Completed Structure in Service.

which was stepped off, as shown in the accompanying drawing, the space above the concrete was back filled with large stone to add to the weight. The rail grillage and method of attaching the "I" bars is the same as in the anchor described above. The weight in this anchor is calculated as follows:

704 cu. yd. of concrete.....	4,517,763 lbs.
1,460 lineal yd. of 54 lb. rail, including anchors.....	88,795 lbs.
178 cu. yd. of back fill material.....	822,828 lbs.
3,341 sq. ft. of shearing surface at 1,000 lb. per sq. ft. ....	3,341,000 lbs.
990 sq. yd. of shearing surface at 288 lb. per sq. ft. ....	285,200 lbs.
<b>Total .....</b>	<b>9,055,586 lbs.</b>

The cantilever arms consist of five panels, one 32 ft. 6 in., one 30 ft., one 26 ft. 6 in. and two 23 ft. The depth of truss varies from 63 ft. center to center of chord pins over the abutment to 22 ft. at the outer end. The cantilever and anchor arms are of the usual design for such structures, the lower chords and verticals being plate and angle sections with "I" bar members for the upper chords and diagonals. The heaviest section which is the cantilever post over the abutment, consists of two plates 36 in. x 15/16 in., and four 6 in. x 6 in. x 7/8 in. angles. The bottom chord pins at this post are 12 in. in diameter and the top chord pins 10 in. The 120 ft. suspended span is a simple Pratt truss

west anchor June 3, 1912, but had to be stopped on July 2 on account of lack of material and three months and 19 days were spent in waiting for this material. Work was resumed on October 21, and on November 22 all main connections had been riveted so that the first train could pass over the bridge. The steel was given two coats of red lead and one coat of graphite bridge paint in the field, the decking being painted two coats of mineral brown in oil after being framed.

The total weight of the bridge was a little less than 3,000,000 lbs. It was erected by force account, the detailed cost being as follows:

Steel .....	\$69,054.70
Decking .....	1,923.00
Anchor reinforcement .....	2,336.06
Paint .....	1,810.75
Freight .....	13,069.30
Masonry, work train service and all labor charges, including supervision .....	62,597.21
	<b>\$150,791.02</b>

This bridge was designed by Messrs. Boller & Hodge, consulting engineers, New York, and was erected by R. S. Cumming and O. G. Meek, resident engineers, and James Goode, foreman, under J. G. Tabler, principal engineer in charge of line.

# DEMURRAGE AS A REMEDY FOR CAR SHORTAGES.\*

A Plea for Higher Charges. Shippers Too Willing to Use Cars for Storage Purposes and to Send Shipments to Be Reconsigned.

BY JAMES O. KLAPP,  
Manager, Wisconsin Demurrage Bureau.

Demurrage and car shortages are twin troubles which have been with some of us for a long time, but are now being transferred to other shoulders for consideration and relief. Demurrage, a word coined in the twelfth century maritime laws of King William, being a charge made for boat delay, was later made to apply to car delay.

Car shortage—what is it? As commonly accepted, is it not a misnomer? From what basis shall we start to compute it? Shall it be the shippers' demand or the market's need? Shall we consider there is a car shortage when transportation companies have supplied the distributor or consumer at market with more cars than he can re consign or unload in a reasonable time? Is it the duty of transporting companies to supply equipment as shippers may want, where the market for which it is intended is already flooded? Is there not a relation between the buyer and seller that must be considered jointly before the railroad company can be accused of dereliction in duty, and the legislatures and your respective commission bodies asked to correct an imaginary wrong? Have not the railroad companies' responsibilities been fairly and squarely met when the market's demands have been supplied with the commodity wanted? Has not the "tail wagged the dog" frequently in the past calamity calls that have been floated to the ears of the railroad officials, legislators and to your respective bodies, and have they not been so persistent that we have accepted without proper reasoning and endeavored to correct an evil that did not exist? Is not this made manifest by passing or trying to pass so-called reciprocal demurrage acts? Do such so-called reciprocal regulations control the matter? We have been experimenting for some years with such laws, but do not the so-called car shortages still exist?

Statistics show the car capacity of all railroads in the United States to have increased 69.22 per cent., and the locomotive or tractive power 109.5 per cent., with an increased business in ton-miles of only 28 per cent., in the past 10 years. Surely it cannot be maintained from these figures that the railroads have not sufficient cars or motive power, or that they have not been active in meeting the demands of commerce.

Others have assigned the failures to a lack of proper terminals. In one terminal, statistics show the average number of cars on hand for unloading during December, 1912, to have been 2,220. There were unloaded of such number 505 cars on the average daily, or but 25 per cent. During July, 1913, the average number of cars on hand was 2,127, the average unloading daily being 644, or 30 per cent. These figures do not include other cars which were on the hold tracks awaiting orders for switching or reconsigning.

May we suggest the question, to what use can increased terminals be used where patrons are not now availing themselves of the facilities already offered? Is it a presumption to suggest that increased terminals will not unload cars? That larger terminal facilities will not relieve so-called car shortages, but, to the contrary, will further aggravate them? Patrons seem determined to use the full visible yard capacity. May we suggest the question, to what use can increased terminals be put where terminals are now in excess of the room necessary successfully to handle the freight going into them, if proper diligence were exercised in the unloading or the proper storage provided by the patrons? Shall a greater overhead expense in

the way of acquiring additional ground and tracks at points where land values have so phenomenally advanced, be forced upon the railroad companies solely to accommodate the storage of surplus shipments that should be unloaded and stored by patrons? In this question of increased terminals, have we not been following the same fallacious principle of the Irishman digging the fence-post hole, who, when asked what he intended to do with the dirt he was taking out, replied he intended to put it back, and when informed that all of the dirt could not be put back, promptly replied that he would dig the hole deeper?

Of grain, a very large tonnage of which is handled by the railroads each year, 90 per cent. is handled through so-called commission firms, whose principal interest in the matter is a large clientage of country or line elevators and farmers, obtaining therefrom a greater number of cars to sell, for the more cars thus obtained the larger their earnings through commissions. Have you ever considered what these commission houses or firms have in the way of their own storage for grain shipped in excess of the market's needs? In a recent hearing before a railroad commission, a grain commission man, under oath, testified that the bulk of the grain moved in a short time, that they had to find buyers after it came, which at all times was not possible to do with the free time now allowed, and that they were compelled to use the railroad companies' cars for storage purposes, as they did not have any of their own.

Another witness testified that he had to buy when the grain was on the market, that they had storage for 80,000 bushels and that their annual business outbound amounted to about 1,500,000 bushels.

While endeavoring to move grain within a short period of time, with storage limited at point of loading and unloading, would not such conditions tend to create a car shortage as based upon the shippers' demands?

We are not familiar with the handling of cotton in the South, but from various talks with those acquainted with the conditions, and from the circulars requesting co-operation in loading and unloading, issued by at least one southern railroad commission, we judge that grain and cotton contribute equally to congested terminals and varied degrees of delays to cars.

The handling of grain through a third party, or a commission house, has created laws providing for inspection either by state or regularly authorized board of trade inspectors. The tariff governing demurrage has conceded the right and allowed free time for inspection thereon. Instances have been cited of grain which moved through fifteen different markets, being subject to official inspection at each of the markets, before it was ultimately unloaded.

There was a time when the coal mines forwarded direct to the consumer as they had orders, when the consumer placed his orders as his needs demanded. In certain bituminous coal fields this practice has been very materially changed. Coal brokers now buy the output of a mine for the year, negotiate as many contracts as possible to take care of such output, depending upon their sales ability to dispose of the surplus, either by overcrowding their contracts or else by finding transient customers.

We have the word of reliable railroad officials that at one terminal as high as 5,000 cars will be on hand at one time, consigned to various brokers awaiting reconsigning instructions, due to "trade conditions," as one so aptly expresses it. Surely it must be conceded that it is not car shortage if there be fail-

\*Abstract of a paper read before the National Association of Railway Commissioners, Washington, D. C., October 30, 1913.



ure to furnish other cars at the mines for the unloading of this same commodity.

Other commodities are fruit from the coast, apples from New York, melons from the South, potatoes from Wisconsin, such commodities being invariably handled through produce commission houses, who too often elect to handle direct from the car rather than put the perishable fruit into cold storage warehouses, using the car as a refrigerator and peddling therefrom as the contents are wanted, the delay to the car being measured by the market conditions.

The detention by consignee of 1,328 cars handled at one terminal in the month of December, 1912, shows an average delay of 7.71 days per car. In the month of July, 1913, on 2,096 cars handled the average detention was 6.78 days. The details of these statistics show cars on hand as high as 76 days, 45, 44 and 43 days. Would it not have been far better for these commodities not to have been shipped until the market was in need of them?

Another compelling factor in so-called shortage is the absolute failure of lake and ocean lines to provide storage for the business forwarded to them or to properly control shipments forwarded to them by rail for transshipment. The maritime laws provide for a demurrage charge where receivers delay the boat unloading. Why should not the same rule apply, on the other hand, against boat line companies where they are the unloaders?

There is still a large class of shippers, namely the manufacturers, whose manufactured or outbound product is generally handled promptly when they can obtain the cars to forward the shipments, but this class of shippers largely helps to create car shortages, the very thing of which they so seriously complain. We so commonly hear nowadays of "our large manufacturing centers." Do we stop to consider that the growth of these centers has created high land values, have we stopped to consider the shortage room for the raw material in ratio to the volume of business which they do? Is it not a fact that in the phenomenal growth of the manufacturing industries the storage room which was theirs at the time they started has been gradually reduced to supply ground for new buildings made necessary to house the machinery for the increased manufacturing? Can you conceive of any manager of one of these large houses providing his own storage where the same can be secured with as much convenience or at less cost in the railroad companies cars?

The foregoing all combine to create a congestion in the railroad yards that retards as prompt switching or handling as could otherwise take place if the excess cars on hand did not make necessary so much reswitching. Complaint of switching delay at terminals is one you often hear, and it has been a question in my mind if the findings in some instances were the result of as deep a probe as necessary to find the real fault.

Cars arriving in excess of commission or brokerage firms' ability to sell result in thousands of cars standing at different terminals. The daily orders for disposition are in small ratio to cars on hand, which necessitates the switching of thousands of cars on hold and inspection tracks that hundreds may be "dug out" and started on their way for unloading. Once started, there are encountered other cars previously ordered and on hand in excess of unloaders' facilities. A consignee with trackage facilities for 3 cars, having 50 cars on hand, with unloading appliances which will enable him to unload 15 cars a day, will demand switching adequate to his unloading appliances, and the railroad companies' difficulties compound with each additional consignee similarly prepared. The miscellaneous unloaders from team tracks, one unloading promptly, the other not, create a daily separation of empties from loads in making room for other cars wanted, more than doubling the switching work on team tracks alone, causing additional cost, for which, up to the present time, compensatory remuneration to the railroad is lacking. This condition makes for car shortage correspondingly to the delayed switching. Shall this be charged to railroad inability or neglect? Is it not at least impracticable, if not well nigh impos-

sible, to furnish motive power and facilities that will meet the demands of the shippers under such conditions where no one is to be benefited thereby?

From the foregoing statement of fact, can it be successfully maintained that the railroads are responsible for so-called car shortages, or cannot it be more directly charged to the severed relationship between the producer and consumer, neither caring for the market's needs, and the manufacturers allowing their cars to stand under load in the outer yards awaiting their time, place and pleasure in unloading, thus shifting the responsibility of storage of the surplus on to the railroad company, whose primary duty is in the transporting of such freight and not in the storage of it.

The question we are trying to answer is, "Can demurrage be used as a greater means for relief of car shortage?" In solving the car shortage problem, do not we also solve the delays in switching and many other kindred complaints which are persistently submitted to your respective bodies for correction? We unequivocally assert, without fear of successful contradiction, that car demurrage is one, if not the greatest agency in correcting the question now under discussion.

The uniform code of car demurrage rules, compiled by your honorable association after many days of research and hard thought, was a great step forward, and not the least accomplished was your declaration that there should be uniformity. May we suggest that the standard of uniformity is the application of the rules, and not the rules in themselves? In all rules so universal in application ambiguity of some and impracticability of others will be discovered only after practical application.

Has a practical operation of the average rule proved true the reason for its adoption? In considering this rule, may we suggest the possibility of the committee having overlooked the factor of small delay to outbound loads creating credits for application to the debits created by the more seriously delayed inbound shipments? The practical working observed with as little prejudice as possible brings out clearly that the greatest benefactors of the average rule are the ones whose business outbound either equals or exceeds the business inbound. The inbound business will accrue credits only where the cars are not being received in excess of their facilities for handling, and under the straight demurrage plan there would be no demurrage accruing under such conditions. But upon the outbound business, such as that done by a grain elevator dependent upon car supply for loading out, the country elevators, or others of like nature, credits will be obtained upon their outbound shipments, not because of any desire to load promptly, but purely because they are equipped or because their business demands it. The country elevator was originally constructed as a matter of economy in handling the grain that is bought. This facility permits of promptly loading numerous outbound cars, obtaining credits thereon which are applied upon inbound coal or lumber that stands in the car as long a period as possible, hauling direct therefrom to fill such orders as they may have or contemplate, and unloading the balance into the coal shed or lumber yard, as their credits may diminish.

As a concrete example of the workings of this rule, we call your attention to the comparative results of two large firms in the city of Milwaukee, who are now working under the average agreement.

	Number of cars.	Days delayed.	Average delay per car per day.
Under straight demurrage—			
March and April, 1910...	2,962	2,339	0.79
Under average agreement—			
March and April, 1912...	3,796	5,525	1.46

Delay under average agreement exceeds delay under straight demurrage rules 0.67 days per car per day.

Actual loss in efficiency, 2,543 car days for two months.

In the foregoing the great bulk of credits was obtained upon the outbound commodity. It was not from any desire to decrease car delay, but purely because shipments had to be made.

The credits thus obtained permitted of the detention on inbound shipments up to a period of seven days without incurring any demurrage charge. We respectfully ask you to consider whether any rule that will permit of an actual loss in car efficiency of 2,543 car days in a 60-day period proves the correctness or incorrectness of the hypothesis under which the rule was promulgated.

Further corroborative of our contention, the credits obtained in January and June, 1913, upon cars outbound were 18,636 car days, compared with debits of 2,332 car days. On cars unloaded the credits were 17,541 car days, as compared with 10,053 car-day debits, the percentage of credits to debits outbound being 12.51, as compared to 57.31 on inbound.

In viewing the average agreement from another angle, at a recent hearing, a signer of the average agreement openly advocated the payment of money in lieu of the "paper credits" which he is now receiving under his average agreement. Although he admitted a responsibility to the railroads and to other shippers in the prompt releasing of cars, yet he advocated a cash remuneration for doing that which he admits is his duty.

Is not this the principle that is now being applied by the signers of the average agreement? Does not the average agreement say to him, hurry the loading or unloading of one car and you may detain another car longer? Was not demurrage created because one fellow did not do himself what he thought the other fellow should do? Shall credits be extended to one for doing that which admittedly it is his duty to do? Were the demurrage rules not intended to be "you must not" instead of "you may"?

We further ask you to consider whether, if there be any merit in a demurrage charge as penalty, the plan for the assessment of demurrage that shrinks the penalty \$3,802 in the month of January, and \$5,000 in June, is taking the corresponding benefit of a demurrage charge away from the question of car efficiency and thus making for car shortage.

May we suggest that what theoretically sounded right has been proven false under practical working, and does it not make for car inefficiency instead of car efficiency? Does it not directly take the car from transportation and make it a warehouse?

The other rule that we would now have you consider, and which is our final thought at this time, is the rate that is now being applied, which at the time of adoption was intended to, and did, stimulate the more prompt release of equipment that it might be put back into service for which it was originally built. Is it not a fact that a dollar of today has not the same purchasing value as 25 years ago? Does it not follow that, being of less value as a medium of exchange, it correspondingly fails of accomplishment in the way of prompt releasing of cars, and that a higher rate is now necessary to obtain the same result that the \$1 charge originally did at its inception?

What can be the argument that will support a successful criticism of a higher rate of demurrage? A measure that will impress the patrons with the necessity of providing their own storage or ordering that their shipments be forwarded somewhere near to the ratio of their facilities for unloading, should not be considered by anyone as being harsh. We respectfully submit that a demurrage charge is an optional charge, not a compulsory one. It is optional whether the patron elects to load or unload the contents or pay car hire thereon. If he elects to stunt his storage facilities and store in cars, does he not do a triple harm in depriving other shippers who may want the equipment, deprive the railroad company of its rightful earnings on such equipment and create a general chaotic condition in the terminal yard with its increased cost in operation to the railroad company? Can he successfully maintain a criticism against a condition of his own making or option? Is he not entitled to pay for his own neglect, carelessness or willfulness? Is he to be permitted to work such harm because he so elects? Can he hope forever to keep in the background his own dereliction, hoping to be protected by your respective com-

mission bodies from a demurrage charge that will force him upon his own initiative? Is this not what he is doing now?

Again we ask what will be the effect of a higher rate of demurrage? Will not the producer forward to market as the market needs, knowing that in forwarding in excess it will be at a much greater cost for storage than he can provide himself? Will not the produce commission man unload the surplus into warehouses, cold storage of his own, or otherwise? Will not the coal broker be more careful with his contracts with the mine operator and order coal forwarded as he has need of it, instead of trying to force a market? Will not the manufacturer prepare himself with more room when the charge for storage in cars is made higher than he can provide it for himself? Will not the car demand be limited to the market's needs and car shortages cease to be a bug-bear?

If these results be obtained by your honorable bodies having granted rules that will not extend the free time and a rate commensurate to the needs, do you not settle car shortage, delays in switching and their kindred troubles by a measure that works injury, if it can be so called, only to the one who elects?

Does it not stop your honorable bodies from having each year to consider such matters and bring corresponding relief to you? Does it not rightfully correct a condition that has grown with the growth of the nation?

Surely it must follow, as the sunset follows the sunrise, that a rate sufficiently high to release equipment will have this effect.

It is not for me to name a rate necessary to accomplish the results that can be obtained. California with its \$6 rate shows better results on prompt releasing of equipment than at its \$3 rate. The \$3 rate shows quicker released and decreased earnings as compared with its \$1 rate. The \$2 and \$3 rate for a limited period on the Canada lines, while showing a more prompt release of cars, also shows an increase on demurrage of \$244,813.35, or 66 per cent.

Does not a graduated scale of charge invite a storage in cars? If a \$3 rate is good for the fourth day, why will it not have the same effect on the third day? Why differentiate in rate after a reasonable time for loading or unloading is granted? Can the increased earnings in Canada, as compared with the decreased earnings in California, be attributed to this cause? It is not increased demurrage that we solicit, but a righteous settlement of the now experienced delay to the railroad freight car. Any charge that increases the demurrage earnings correspondingly fails of the results to be obtained by corrected demurrage rules or a higher rate of demurrage.

The question of amending the present demurrage rules and their application is one which sooner or later must be taken up and settled, but cannot remain unsettled for long. So-called car shortages are with us, and car demurrage can be used as an instrument to allay the complaint.

**RAILROAD CONSTRUCTION IN THE PHILIPPINES.**—The construction work on the Baguio branch of the Manila railroad has progressed so far that the passenger equipment has been ordered and is expected to arrive during the latter part of 1914. The branch is to be 24 miles long. The roadway has already been completed on seven miles at each end. Sixty per cent. of all the roadbed material is already in place, and on June 30, four miles of track had been laid. The construction of bridges along the line has not progressed very rapidly, for but three of the 123 bridges have been completed. Special rack-track material which will be used for eight miles of the road, where a rack-track system will be installed, has been ordered and delivery is expected to begin soon. One second-hand rack locomotive has been delivered and will be used for construction purposes. Ultimately six rack locomotives will be used in the regular service. Three of these are expected to arrive by March and the remainder by November, 1914. There are three tunnels under construction and one is nearly completed. The construction force at present numbers 3,500.

# INTERSTATE COMMERCE COMMISSION'S ANNUAL REPORT.

## Succinct Summary of the Commission's Multifarious Judicial and Administrative Operations During the Past Year.

The twenty-seventh annual report of the Interstate Commerce Commission, dated December 15, was sent to Congress December 19. It opens with figures showing in part the great increase in the work of the commission which has taken place during the past year. It has become almost impossible for the commissioners to absent themselves from Washington and they are arranging to delegate more of their work to subordinates. Seven thousand six hundred informal complaints have been received during the year, 1,050 more than in the preceding year. Refund of overcharges has been authorized in 4,610 cases, an increase of 1,514 over the preceding year; total amount thus awarded \$349,167. Nearly 2,000 applications of this kind have been dismissed—twice as many as in the preceding year. Relief from the provisions of the fourth section—the long and short haul section—has been granted in 1,256 cases; of these 1,256 orders 1,057 were for temporary relief. New tariffs have been suspended in 159 cases, or 39 more than in the previous year. In 32 cases the roads withdrew the tariffs; in 41 the changes were allowed; in 32 they were allowed in part; in 42 disallowed and in 4 cases the protests were withdrawn.

Formal complaints received during the year numbered 1,023, an increase of 268 over last year; 724 cases have been decided and 139 have been dismissed. Hearings conducted during the year, 1,401; increase 247; testimony taken, 140,000 pages, or 15,000 more than the preceding year.

During the 12 months ending with November, 141,257 tariffs were filed, an increase of 32,500 over the preceding 12 months. Under the improved regulations of the commission the number of tariffs filed has steadily decreased and is now smaller than at any time since 1906.

*Work in the Courts.*—The commission has secured 61 indictments in the courts for criminal violations of the act to regulate commerce; 28 against carriers, 33 against shippers, etc.; prosecutions concluded 72, including 50 cases in which the defendants pleaded guilty. In the cases where the government lost, a new trial will be secured under another section of the law, or by some means. Aggregate fines imposed during the year \$145,400. The prosecutions were spread over territory including 20 states. The record of the year shows fewer prosecutions and a smaller aggregate amount of fines recovered; but the value of the law is not to be measured by these figures; there is a gratifying tendency among carriers and shippers to conform to the law more carefully than ever before. False billing of freight by shippers continues, and \$16,750 in fines has been recovered in this field. These offences are being vigorously prosecuted. False claims for damage are also being followed up.

The privilege of stopping freight in transit continues to be abused in many places. These cases will be followed up. Discrimination by failure to collect demurrage charges has been investigated on a number of prominent roads. There have been during the year a large number of cases in which the courts have condemned a variety of ingenious schemes for rebating. These are set forth to the extent of a half dozen pages. Investigations of conditions on the anthracite coal roads and into the relation between rail carriers and water lines have developed the need of a number of amendments to the law; in particular, the commission wants authority to examine all correspondence files, indexes and other papers found in carriers' offices.

Sixty-one indictments have been returned in the courts during twelve months for violations of the act to regulate commerce and 72 prosecutions have been concluded; these are all described in two lists filling ten pages of the report.

The Intermountain rate cases, dealt with under the fourth section of the law, and other cases coming under this section,

are discussed in the report at length, as is the action which has been taken on the Western freight classification.

The five cases decided by the Supreme Court of the United States during the past year are briefly reviewed. These are the New Orleans Board of Trade case (Louisville & Nashville), the Omaha Bridge case, the Lemon case, the New York Lighterage case, and the Kansas City Southern accounting case.

The only suits brought against the commission in the Commerce Court during the year have been the Tap line cases. The Commerce Court has granted preliminary injunctions in the Pipe line cases. During the year that court has upheld seven orders of the commission, has dismissed five and has decided against the commission in five. Twelve cases are pending in the Commerce Court.

*Carriers' Accounts.*—The commission continues to receive the co-operation of the carriers. "There is a growing appreciation of the importance of exact and theoretically correct accounting, and there is less tendency on the part of the carriers to hold that they may adjust their accounting systems to their own situation or needs." Steps will be taken to compel delinquent carriers to comply with the requirements of the commission in the matter of charging off depreciation. While the commission in the future, as in the past, will not prescribe the forms of entries which carriers are to make in their own books, it does propose to lay down a general rule which will insure a greater degree of order and clarity in those books. New regulations have been prescribed for the accounts of carriers by water and for telephone companies. Rules for telegraph companies will soon be issued. The order prescribing the length of time that records must be kept before being destroyed will be revised at the beginning of January. Reference is made to standard rules for the settlement of freight claims which have been under discussion with committees of the Freight Claim Association. [Since the report came out the commission has approved the form of blank which was agreed upon by the Freight Claim Association for the presentation of claims.]

*Statistics.*—That part of the report devoted to statistics gives the aggregate of the income accounts of steam roads having receipts in excess of \$10,000,000 for the year ending June 30, 1913, the figures being separated into the Eastern, the Southern and the Western districts. This table fills a page and includes returns from railroad companies operating 184,483 miles of road. Other tables are: A summary of the monthly reports of revenues and expenses of steam roads having annual receipts over \$1,000,000; this covers 221,749 miles; receipts and expenses of steam roads with the receipts of over \$1,000,000 for the three months ending September, 1913; and similar statements for the same quarter in the six years preceding; a table showing, for these same roads, and for the same quarters, the averages of receipts and expenses per mile of line operated; a statement of the mileage of railroad and other lines operated by the principal express companies, 1913 compared with 1912; a statement of the revenues and expenses of the principal express companies for 1913 and 1912; revenues and expenses of the Pullman Company for the three months ending September 30, 1913; and five pages of summaries of railroad accidents for the year ending June 30, 1913. Some of these accident tables go into great detail. For example, derailments due to broken arch bars are given for ten years, similar figures are given under the head of rigid trucks, irregular track, bad ties, soft track, etc.

The Division of Statistics now issues a daily bulletin for the benefit of the press, showing earnings and expenses of railways as reported for the latest month. Reports begin to come in about the 25th day of the following month and as soon as a sufficient number are on hand to make an instructive table a bulletin is

prepared. [Similar to the tables published regularly in the *Railway Age Gazette*.] A preliminary abstract of the statistics of carriers for the year ending June 30, 1913, will be issued as soon as practicable. The commission intends to revise the forms on which the railroads make their annual reports.

*Safety Appliances; Hours of Service.*—In many cases cars are still run in defective condition, when minor repairs would make them safe. This is because of inefficient inspection. Former bad conditions have been somewhat remedied, but there is still room for improvement. The railroads are not working fast enough in their compliance with the order of March 13, 1911, requiring compliance with additional safety standards.

One hundred ninety-one prosecutions have been begun for violation of the safety appliance act. Of 91 counts dealt with in trials in courts, 56 were decided in favor of the government. Of 35 counts decided in favor of the roads the government has appealed in regard to 31. Penalties aggregating \$56,800 were collected during the year.

Eight pages of the report are taken up with accounts of decisions by the courts on the safety appliance act, the ash pan act and the hours of service act. All sorts of minute details in the construction of the laws are here considered and, judging by the numerous appeals and the conflicts between different decisions these matters will engage the attention of the courts for a long time to come. The roads reporting on the hours of service law numbered 1,222, of which 737 reported each month that there were no cases to report. The remaining 485 carriers reported 301,743 cases in which men were on duty for longer periods than those named in the law. Careful and elaborate analyses of the facts gathered in these reports have been prepared and have been sent to the railroads; and there has been a gratifying improvement. On one road the number of cases of excess service was reduced within a period of two months from 2,024 to 84. Penalties imposed by the courts for violation of the hours of service act have varied from one cent to \$250 per count, and the commission asks for a more specific law naming the penalty, or a minimum penalty.

*Investigation of Accidents.*—During the twelve months ending June 30, 1913, the inspectors of the commission investigated 51 collisions and 25 derailments, which caused the death of 283 persons and the injury of 1,880. The causes were of the same kind as those reported heretofore for similar accidents, and which have been discussed already. Commenting on this feature of the situation the report says:

"Either a great majority of these deplorable disasters are unavoidable, or there exists a widespread lack of intelligent and well-directed effort to minimize the mistakes of employees in the operation of trains. All of the mistakes noted are violations of simple rules, which should have been easily understood by men of sufficient intelligence to be entrusted with the operation of trains. The evidence is that in the main the rules are understood, but they are habitually violated by employees who are charged with responsibility for the safe movement of trains. The evidence also is that in many cases operating officers are cognizant of this habitual disregard of rules, and no proper steps are taken to correct the evil.

"Many operating officers seem to proceed upon the theory that their responsibility ends with the promulgation of rules. On very many railroads there is little or no system of inspection or supervision of the work of train-service employees, so far as pertains to those matters which vitally affect safety. Employees are not examined on the operating rules, except at the time of their promotion, and only the most perfunctory efforts are made to determine their fitness to perform the duties assigned to them from time to time.

"This lack of supervision and inspection with respect to matters affecting the safety of trains is unexplainable, when the careful supervision of all matters directly affecting the revenue of the roads is considered. The auditing and checking systems used for detecting the dishonesty of employees are marvels of ingenuity and careful attention to detail. . . . Fourteen accidents

investigated since July 1, 1911, were caused by enginemen running by stop signals. No adequate reason can be offered for these serious lapses from duty by men who, in many cases, suffer death as a consequence. The trains involved in these lamentable disasters generally are operated by trusted employees of long experience. These facts are brought to the attention of the Congress, with the suggestion that these man failures indicate the necessity for the development and perfection of some system of automatic train control to be used in connection with existing signal systems. . . . The maximum allowable speed of trains on all roads should be established at a safe limit. Legislation should be enacted prohibiting the use of wooden cars in high speed through trains after a certain date. Reasonable time should be given the carriers for compliance with the provisions of any law of this kind. There are a great number of wooden cars now in service, and the carriers should be permitted to make use of these cars on branch lines and in local service until they can be replaced, but the law should provide that all new cars constructed after a certain date should be made entirely of steel or of steel underframe construction of approved design.

"The only purpose of investigation is to learn the true causes of accidents so that such causes may be eliminated as fully as practicable. It is manifestly impossible for the commission fully to accomplish such purpose unless empowered by law to enforce its recommendations. Furthermore, the commission should be authorized to conduct independent investigations with respect to all matters affecting the safety of railway travel, the object being to prevent accidents as far as possible, rather than, as at present, merely to point out the causes of accidents after their occurrence. There is particular need for an investigation of steel rails and car wheels. . . ."

*Miscellaneous.*—The report next takes up the inspection of locomotive boilers, which subject is dealt with elsewhere in this issue.

The commission has given notice that applications by railroads for extension of time under the Panama Canal act, in the matter of maintaining ownership of water lines which may compete for traffic, must be presented to the commission not later than March 1, next.

The report tells what the commission has done to carry out the act of March 1, 1913, requiring it to make a valuation of the property of all common carriers. An organization has been established, but the number of applicants for places, under the Civil Service Commission rules, was so large that the preparation of rolls has been much delayed. The roll of engineers of the higher grades, for which there were 6,000 applicants, was not available until October 23, and the junior roll was not ready until November 20. To compile the statistical history of the railroads many trained accountants will be required, in addition to those already employed by the commission. Land appraisers and telephone and telegraph engineers are yet to be dealt with, the examinations being only recently completed. For the higher grades careful examination had to be made, not only on the basis of data presented by applicants, but also to learn the standing of the candidates in their home localities and their records with past employers. It is expected that actual operations in valuation will be begun early in January. In each grand geographical division a railroad will be selected which can be valued in an experimental way. Railroads of different classes will be chosen. After a few months of experimental work it is expected that good progress can be made.

The report tells what the commission has done under the parcel post law, which requires it to advise the postmaster general and approve changes made by him. The commission desires to be relieved from the duty of determining the extent to which the parcel post ought to supersede the express system and, in fact, to be relieved of all duties in connection with the parcel post.

*Recommendations.*—Among the recommendations for new legislation not already mentioned are the following:

That one period, three years, be fixed for the beginning of all legal actions relating to transportation charges. Difference in

statutes of limitation produce injustice. A carrier which fails to demand payment of charges for transportation within ninety days should be deemed guilty of giving a rebate to the shipper. All suits brought to enforce or set aside orders of the commission should be directly under the supervision of the commission, instead of as now, under the Department of Justice. At present much work is duplicated.

It is recommended that the commission be authorized to make orders, after investigation, respecting the construction and maintenance of the physical properties of railroads and rules and regulations pertaining to the use and operation of such properties.

That the commission be given control and supervision over railway capitalization.

That the commission be empowered "to require the use of block signal systems and to require the adoption and use of steel or steel underframe cars in passenger service."

## PRELIMINARY CONSIDERATIONS IN THE DESIGN OF OPENING BRIDGES.

By HENRY GRATTAN TYRRELL,  
Consulting Engineer, Evanston, Ill.

The design of movable bridges is affected by the relative height of the railway grade and water, the number of movements on both thoroughfares, the depth and width of channel and the kind of shipping. A moving bridge which is well fitted for crossing a barge canal would evidently be unsuitable for a deep water course.

### RESTRICTIONS ON OPENING BRIDGE CONSTRUCTION.

Low level structures with opening spans are prohibited by law on some of the largest and busiest water courses, such as the lower Mississippi and the Ohio, where it is required that sufficient underclearance be provided for the free passage at all times of all kinds of river craft. As the size of these large rivers diminishes towards their source with a proportionate diminution or total cessation of shipping, low level bridges either fixed or with a moving span are permissible. This condition is illustrated on the upper Mississippi, which has many bridges with spans arranged to float or swing.

Many of the busiest waterways in America are the river mouths at cities on the Great Lakes and seacoast, such as Chicago, Milwaukee, Cleveland and Boston. On the Chicago river, to avoid interruption of street travel, all bridges must remain closed between 6 and 8:30 a. m., and between 5 and 6:30 p. m. Other busy rivers in America are Newtown creek and Harlem river at New York, which have widths of 150 and 400 ft. respectively. Some of the busiest rivers in Europe, such as the Seine at Paris, have no masted ships, and as the steamers have hinged smoke stacks opening bridges are unnecessary.

In flat countries, the flow of rivers is fairly uniform, but in mountainous regions, such as Northern India, the rivers are usually subject to very sudden rise. Those draining the Himalayas begin to rise early in April, and the water continues high through the rainy season from the middle of June to the end of August, the greatest flow being in the months of July and August. The Indus river has a maximum rise of 6 ft., while the Hooghly is 36 ft. deep at low water, with a maximum current of 6 to 7 miles per hour, though the average flow is only about  $4\frac{1}{2}$  miles per hour. A pontoon bridge at Calcutta has its floor 15 ft. above the water, high enough to permit small boats to pass under without opening the draw.

The canal system of France is probably the most elaborate one on the globe, for there are no less than 3,000 miles of navigable inland waterway under state control. Some of them are very narrow, such as the Burgundy canal at Dijon, which is only 20 ft., while others are wider, as the Ourcq at Paris, which is 30 meters. Most of the canals in Venice do not exceed 15 to 25 ft. in width.

The Erie canal, through New York state, has a normal width

of 60 ft., which is too narrow for swing bridges with center piers. The Miami and Erie canal in Ohio has a normal width of 50 ft., sufficient for three boats, each 15 ft. wide, but at the crossings, the openings are frequently reduced to 32 ft., leaving only enough space for two boats to pass. The usual width of freight boats on the Great Lakes of America is 50 to 52 ft. for the largest ones, with an extreme width of 56 ft. for propellers and 75 ft. for side wheel boats, the length varying from 400 to 500 ft. Barge canals in America use smaller boats, 15 ft. being the standard width on the Miami and Erie system, as noted above.

### VARIABLES IN DESIGN OF OPENING BRIDGES.

When the water course is wide enough for a center pier, two channels are frequently more convenient than a single one, as travel in the two directions is then divided. This is illustrated by the bridge over the Harlem river at New York, where two openings of 100 ft. are provided, with a space of 50 to 100 ft. between them, in preference to one opening of 200 ft. The channel width of 400 ft. is crossed by swing bridges 300 ft. long, leaving a clear channel of 50 ft. on each side for boats. Dock space should not be obstructed more than necessary, for it is frequently worth \$200 or more per front foot.

The required length of opening over navigable water courses in the United States is regulated by law. Previous to 1870, two clear openings of at least 160 ft. were required on the Mississippi, Missouri and Ohio rivers, resulting in swing spans about 360 ft. long; but in 1873 a new law was enacted increasing the length of clear openings to 200 ft. Under this new law, the usual length of swing spans is 440 ft. to 450 ft., depending on the width of bridge and center pier. On the Chicago river a clear bridge opening of 100 ft. is required on the north branch, and 140 ft. on the south branch and main stem, though the old Clark street swing, with a center pier, gives two clear openings of only 67 ft., which are now the narrowest on the river. In 1908, a commission appointed to report on the matter recommended clear openings of 200 ft. on the south branch, but this recommendation has not yet been put into effect. The Harlem river at New York requires two openings of 100 ft., while the Gowanus canal in Brooklyn has only one opening of 50 ft.

In Rotterdam and Amsterdam, Holland, the length of opening spans is usually less than half the canal width, the remaining part being crossed by an approach span at each side with a clear waterway underneath. Those designs in which the side spans do not obstruct the water flow are usually preferable to others where the abutments or tail-pits cut off the channels.

Any increase in clearance under the bridge usually tends to decrease the number of bridge openings, for when high enough above the water, many small boats can pass under. Water courses for barges only, such as the Erie canal in New York state, and the Miami and Erie in Ohio, require a headroom above water not exceeding 9 to 12 ft., and where this height is obtainable with a fixed span, a movable one is not needed. In flat countries with land and water at nearly the same level, it is more difficult to gain the needed under-clearance. The center clearance under bridges on the Chicago river is  $16\frac{1}{2}$  ft., which is reduced towards the side by the arch outline of the bottom chords. It was proposed in 1908 to increase the clearance by using horizontal bottom chords on all opening bridges. At Harlem river and Newtown creek, New York, the clearance is 24 ft., and over the Charles river at Boston it is 23 ft., while the corresponding under-clearance is  $29\frac{1}{2}$  ft. at the Tower bridge in London.

The number of bridge openings over a water course may not be proportional to the volume of shipping, but will depend largely upon the under-clearance. This should be great enough that small boats can pass, and as much higher as the resulting saving of time will pay interest on the extra cost of building at

higher level. These matters are subject to computation, and the proper height can be quite closely determined. Bridges should never be so low that a small boat or tug would have the power to obstruct or delay whole trains of passengers during the time of heavy travel. The old Point street swing of 1874 at Providence was opened 100 to 175 times per day, and at certain hours was allowed to remain closed only two minutes at a time. The same method of building bridges too low was common in Holland previous to 1850, with the result that they were usually kept open for water travel, until they were finally replaced. Many other bridges with insufficient under-clearance have been replaced by higher ones requiring fewer openings.

On the Erie canal it has been found that the busiest months for shipping are September and October, when the daily average movement of boats in both directions is about a hundred.

Those bridges nearest the harbor mouth, as at Rush street, Chicago, and Broadway, Milwaukee, are usually more active than others farther inland. Bridges over channels which carry little or no shipping, such as those at Indiana Harbor, are opened only often enough to keep the parts in working order.

#### SUBSTITUTES FOR MOVABLE BRIDGES.

Movable bridges, which are chiefly over navigable waterways, are not desirable and should be avoided wherever possible, for they delay travel, and each one represents a possible accident. They have a greater use in America than in Europe, for the more conservative engineers of Great Britain and the Continent prefer fixed spans even at greater cost, knowing that the expense of one accident may pay the extra cost of a high level structure.

In addition to movable bridges, ferries or floating bridges at water level, high-level bridges and tunnels may be used for crossing navigable waterways. Ferries are at best a makeshift, and are excusable only when nothing better is obtainable. High level bridges and tunnels may be approached at the ends by long inclines or by elevators, the former being the usual practice.

#### HIGH LEVEL FIXED BRIDGES.

The choice between a high level fixed bridge and one at a lower level with an opening span may often depend more on efficiency than on first cost, for, on account of the necessity for saving time, high level bridges, which are always open for travel, are often preferred. For this reason, most of the bridges on through lines in England, such as those over the Grand Junction canal between London and Birmingham, and over the Liverpool and Leeds canal, are fixed at a high level with long approach grades of 3 to 5 per cent., though a few of them are made to swing. High level bridges are also used for crossing the Forth, Tyne and Tay rivers, and the Menai Straits. The chief use of movable bridges in Great Britain is for crossing harbor entrances or docks where masted ships enter, and where train delays may be of less importance. Fixed bridges are generally used also in the rural districts of Holland, but in so flat a country with land and water at nearly the same level, the long approaches needed for fixed spans make movable ones preferable in the cities. Twenty years ago, the city of Amsterdam had no less than 340 bridges, of which only 37 were movable. Fixed bridges are the rule also in France, with its more than 3,000 miles of inland canals.

The difference between European and American practice in the use of high and low level bridges is quite striking, for in America low bridges are rather the rule than the exception. Almost every railroad, even those carrying the heaviest passenger travel, makes frequent use of low level bridges with a moving span, and endeavors to protect travel by safety devices. In order to use a low level bridge and still avoid an opening span, it was proposed in 1826 to use sunken locks beneath the bridge over the Thames at London, and a similar plan was proposed in 1890 for the Erie canal at Rochester. These plans were not favored because the expense of construction and mainte-

nance would be great and much delay would be caused to shipping.

A comparison between high level fixed bridges and lower ones with opening spans shows but little difference in first cost, though there is usually a saving of 10 to 15 per cent. in favor of low structures. The chief difference is the cost of approach, for a bridge with a clear underneath height of 135 ft., as that over the East river at New York, with grades of 3 to 5 per cent., would necessitate approaches at each end 4,500 ft. to 2,700 ft. in length, respectively, and if the approach should lead up from more than one direction the cost of the overland construction would be increased. The opening bridge has a yearly operating expense which is avoided in high level structures.

The cost of approaches may be reduced by placing the bridge floor high enough above water to clear all ordinary craft, with an opening span over the channel for occasional use only. In some places, however, where the amount of shipping is great, as on the East river at New York, the high level bridge with under-clearance high enough for all kinds of vessels is imperative. In most other cases, however, a lower bridge with an opening span is preferable to a fixed one, both as to cost and utility. A combination of high level bridge and swing span can sometimes be used to advantage, the deck being placed 40 to 50 ft. above water, so that all ordinary boats can go under it.

#### TUNNELS.

Bridges have always been more favored than tunnels, and until recent years tunnels were considered suitable only for locations where bridges were impracticable or impossible. Their chief advantage is the formation of a communication across the water that is free from interruption and open at all times for travel, thus saving much time. At Detroit, the saving of time by the use of the tunnel is 15 to 20 min. for passenger trains and three to four hours for freight trains. As compared with high level bridges, tunnels require much less land area for their approaches, and the cost of real estate is proportionately less.

The objections to tunnels are many, some of them being as follows: approaches must either be long or have a steep grade; the time consumed in passing through a tunnel is greater than crossing on the level, in proportion as the tunnel is longer than a moving bridge; they are usually insufficiently supplied with air and light; they have no advantage over a bridge in winter seasons, during the period when shipping is discontinued and bridge openings are unnecessary; tunnels are disliked by the public, and are tolerated only from necessity; their first cost is frequently 10 to 15 times that of a bridge with an opening span; they need ventilating, pumping and lighting, and have a high maintenance cost; if it becomes necessary to deepen the channel, the whole tunnel may have to be rebuilt, and during the rebuilding, all traffic is stopped, and the time required for building tunnels is much greater than for bridges of the same capacity.

The great progress made in tunnel construction during the last twenty years, due to the use of improved shields and other modern appliances, has made it possible for tunnels to compete with bridges for crossing water courses, where piers cannot be used, such as those at Sarnia, East Boston and New York. The cost of tunnels is usually much greater than that of moving spans, those through hard rock generally being the cheapest and easiest to build.

The cost of tunnels depends greatly upon the depth below the water, and the resulting length. While the greatest ships afloat, such as the *Mauretania*, have a maximum draft of only 33 ft., modern subaqueous tunnels are being placed low enough to provide a deeper waterway, those at New York and Liverpool being 40 ft. below water, while that at Detroit is 41 ft. 9 in. The Panama locks are being built to accommodate ships of 45 ft. draft. The rough approximate cost per sq. ft. of roadway for high level bridges, bascules and tunnels may be taken at \$5, \$10 and \$20, respectively.

## THE CONGESTION ON THE PRUSSIAN STATE RAILWAYS IN 1912.\*

By G. ALLIX.

Towards the end of last year the *Journal des Transports* pointed out the critical situation existing on German railways in the autumn of 1912 which was doing such serious injury to the metal and coal industries, especially in Westphalia. At that time the figures for December were not yet known, but since then complete statistics for the year 1912 have been published and the situation, which has been taken even to the Reichstag, has given rise to various discussions, among which we may cite the article from an authoritative source which appeared in the *Revue Generale des Chemins de Fer* for last August. The question is interesting not only in itself, but on account of the lessons to be drawn from what has taken place in Germany.

The report for 1912 of the committee of coal operators of Westphalia contained statistical information which the central committee of coal operators of France published in its circular of October 20 last. These statements showed that in 1912 in the different regions of Germany from which coal and lignite are shipped there was a total shortage of 1,051,334 cars, of which 56,326 were for September, 344,357 for October, 391,094 for November, and 201,638 for December.

When we take into consideration the different regions served by this railway system we see that in 1912 there was a shortage of:

- 538,226 cars in the Ruhr;
- 153,480 cars in Upper Silesia;
- 108,970 cars in the Magdeburg-Halle-Erfurt region;
- 64,693 cars in Saxony;
- 71,675 cars in the Rhenish lignite basin;
- 18,008 in the Aix-la-Chapelle region.

Thus it is the region called the Ruhr which has suffered the most by far. Following is a table of shortages for the last three years. From 50,669 cars in 1910 there was an increase in 1911 to 237,256, and this number was more than doubled in 1912. The table gives these figures in detail, month by month.

CAR-SHORTAGES IN THE REGION OF THE RUHR, BASED ON CARS OF 10 TONS EACH.

	Number of cars not furnished in time.			Percentage of the demand.		
	1910.	1911.	1912.	1910. Pct.	1911. Pct.	1912. Pct.
January .....	...	...	9,464	...	...	1.3
February .....	...	179	1,565	...	0.03	0.2
March .....	...	195	4,618	...	0.03	0.8
April .....	...	402	5,226	...	0.1	0.7
May .....	264	2,026	1,229	0.05	0.3	0.2
June .....	...	80	...	...	0.01	...
July .....	...	1,525	679	...	0.2	0.1
August .....	217	7,441	3,579	0.03	1.04	0.4
September .....	9,368	24,904	24,092	1.4	3.5	3.1
October .....	17,616	121,720	177,398	2.6	15.9	19.3
November .....	17,524	66,204	231,777	2.7	8.8	26
December .....	5,680	12,580	78,599	0.9	1.8	9.2
Total for year...	50,669	237,256	538,226	0.7	2.9	5.8

It is evident how much justification there was for the apprehensions expressed during October by the selling syndicate of the Westphalian coal mines which feared that the approaching necessity for the transportation of the beet crop would aggravate a situation that had been very annoying during the first half of October. In the basin of the Ruhr alone the proportion of unfilled orders for cars, which was very slight in August, rose suddenly to 3.1 per cent. in September; then mounted to more than 19 per cent. in October, reached the enormous figure of 26 per cent. in November, and then dropped to 9.3 per cent. in December. Transportation which in normal times required from 24 to 36 hours then took eight days. There was a partial suspension of production at an increasing number of mines, which caused losses of tens of millions to the

operators and was disastrous to the laborers, whose wages represent 50 per cent. of the price of the coal produced.

The *Zeitung des Vereins Deutscher Eisenbahnverwaltungen* treats the situation resulting from this crisis as follows:

"A very disquieting aspect of the freight traffic of our railroads is that shown by the trouble experienced in the months of October and November last, particularly in the Rhenish-Westphalian districts, trouble which this time has reached a condition so serious that its gravity is not as yet known. It was not merely because of the lack of cars which usually occurs to a limited extent during the autumn months when the products of mines, of industry and of agriculture require shipment all at once. This time it had to do with actual disorder and congestion of traffic in a series of stations. According to the declarations of the Prussian Minister of Railways the number of cars had increased on July 1, 1912, by 33,836, or 8 per cent. over the 450,000 cars of the preceding year. The crisis is to be ascribed less to the shortage of available cars than to the work of reconstructing stations in the West, and as yet unfinished. The railway administration was obliged to take recourse to the extreme measure of suspending for 4 days, from October 26 to 29, the receiving of cars loaded with freight from one section of the stations on the left bank of the Rhine as well as cars consigned to Belgium, Holland and France, by way of frontier stations between Herbesthal and Venlo. But these measures could be only a temporary palliative, insufficient to put an end to the congestion of the system which continued and reached its height in the middle of November. At the same time mining and industrial corporations and chambers of commerce in all sections gave voice to the liveliest complaints in the press and even in the Reichstag.

"It became necessary, as a result of these disordered conditions, to close certain coal mines and to suspend operations in certain manufacturing works more or less completely. The principal cause of all the trouble has been the extraordinary and unforeseen development of traffic in the districts concerned. A 7 per cent. increase of traffic had been counted on, but the increase reached an average of 17 per cent. in the coal mining centers, and in some places was 28 and 30 per cent."

All the coal-producing regions of western Germany have suffered for lack of rolling stock, but not all in the same degree. The district of the Sarre, which like the railways, is controlled directly by the state, has been the most favored. This is perhaps a mere coincidence, but it is unfortunate; the administration, like Cæsar's wife, should be above suspicion.

The question of the causes of the crisis and the means of preventing its recurrence were discussed in the Prussian parliament in November and December, 1912, and gave rise to statements by Minister of Railways von Breitenbach. In January, 1913, in the Reichstag, Mr. Wackerzapp, president of the Imperial Railway Office, replied to the interrogation of the Social Democratic party. According to these authorities the disturbances which have been so strongly felt are due particularly to the lack of facilities of certain freight stations and to the extraordinary development of the traffic, which passed beyond all expectation. Estimates had always been too high from 1907 to 1909, but from 1910 they were too low. In 1910 and 1911 increases of 5.7 per cent. and 2.1 per cent. respectively had been counted on, but the actual increases were 6.5 per cent. and 4.8 per cent. For 1912 the calculations made, as Mr. Wackerzapp remarked, with the assistance of the representatives of the industries, estimated the increase at 7.5 per cent., but the actual increase was almost three times that estimate.

In 1906 a plan was formulated for construction to be carried on during a period of ten years, at a cost of \$579,144,750. From 1907 to 1912, \$506,625,000 was expended in betterments and in adding double, triple and quadruple tracks, a third of which were in the district of the Ruhr and its vicinity, although in this district is not more than 11 per cent. of the whole railway system of Prussia.

\*In the *Journal des Transports*, November 22, 1913.

In addition to this the average annual expense for replacing and increasing the rolling stock used in operation was \$26,078,000 from 1900 to 1905, and \$53,075,000 in the period 1906-1913. The investment in freight car equipment averaged in the first of these periods \$9,167,500, and in the second \$17,563,000. The capacity of the freight cars has increased slightly, rising from 6.29 tons per axle in 1900 to 7.01 tons in 1910.

As to locomotives, increase of utilization was 33 per cent. from 1907 to 1912, increase in tractive power 76 per cent., while in the same time the ton mileage increased 41 per cent. It can not be denied that a very serious effort has been made to improve the situation, but certain critics consider it insufficient. The Chamber of Commerce of Dusseldorf observes that the new locomotives, whose power is 7.6 per cent. greater than those of former years, have been in service only a short time and their number is not yet very large. This chamber has made up the comparative statement given below of the increase in rolling stock and of traffic on the Prussian railways during the last ten-year period.

Years.	Locomotives.		Cars.		Traffic.	
	Utilization.	Increase. Pct.	Utilization.	Increase. Pct.	Millions of tons.	Increase. Pct.
1900.....	12,871	...	284,670	...	231.0	...
1901.....	13,200	2.5	288,242	1.2	229.1	0.82
1902.....	13,720	3.9	291,016	0.9	237.9	3.86
1903.....	14,322	4.4	300,017	3.1	258.8	8.78
1904.....	14,837	3.6	310,653	3.4	269.1	3.96
1905.....	15,368	3.6	324,618	4.5	294.9	9.59
1906.....	16,184	5.2	347,410	7	318.6	8.04
1907.....	17,320	7	372,843	7.3	344.3	8.06
1908.....	18,483	6.7	392,494	5.2	333.6	3.10
1909.....	19,394	4.9	405,900	3.4	354.3	6.20
1910.....	19,886	2.5	420,728	3.6	390.5	10.23
1912.....	...	...	450,000	6.9	.....	.....
		54.5		47.8		69

The Chamber of Commerce concludes from these figures that the Administration of the Prussian state railways has placed insufficient orders for cars in previous years and that the shortage in rolling stock is thus due to its lack of foresight. But how is this? Is the boasted regularity of the German orders for equipment, so often held up as an example to the French companies who are inspired by a wise spirit of opportunism, no more than a pretence? We cannot but so believe, for the Minister of Railways has himself criticized before the Prussian Chamber the principle of the placing of regular orders. "It has been pretended," he said, "that the railway administration ought to increase its stock regularly and uniformly according to a determined percentage. It would not be wise to proceed in this way under all circumstances, for it is always well in times of economic depression not to exercise undue restraint in purchases. I realize, of course, that a railway administration ought to be equipped to cope with an estimated maximum of traffic, but when the amount of this traffic reaches the proportions which we have at present I doubt if difficulty could be avoided, for even with sufficient rolling stock it would be necessary to realize that the capacity of stations is insufficient, to say nothing of the number of employees which would have to be kept to meet all possible needs."

However that may be, it is quite evident that during the last months of 1912 on the Prussian system there was no fair adjustment of the capacity of the trackage of the system and the utilization of rolling stock to the necessities of the traffic. For the whole of the system supplied by the Car Union the supply of open cars in 1912 exceeded that of 1911 by 11.2 per cent. in April, 3.5 per cent. in May, 11.6 per cent. in June, 15 per cent. in July, 12.3 per cent. in August, 10.3 per cent. in September, 16.9 per cent. in October, 9.5 per cent. in November, and the proportionate increase was higher still in certain special districts, as in that of the Ruhr. But the insufficient station facilities and tracks impeded the movement; the congestion clogged the switching tracks; the irregularity of the movement completely deranged the schedules, disorganizing the whole service.

To prevent the recurrence of such conditions it has been decided to accelerate the provision of additional facilities and

extensions on all the western part of the system and to furnish more liberal supplies. This work has been especially expedited during 1913.

It is interesting to perceive that even a country ordered and disciplined like Germany is not protected from the inconveniences that beset at times all transportation agencies. There are times when the development of traffic surpasses all estimates. The explanations given by the Prussian and the imperial governments show that no railway administration can flatter itself that it can entirely avoid crises such as those to which we have just referred.

### REPORT OF CHIEF INSPECTOR OF LOCOMOTIVE BOILERS.

The annual report of the chief inspector of locomotive boilers, for the fiscal year ending June 30, 1913, shows a marked decrease in the number of casualties due to failure of locomotive boilers and their appurtenances and a substantial improvement in the condition of such equipment, when compared with the report for the preceding fiscal year. The following is taken from this report:

Knowing that it would be impossible to correct at once all defective and improper conditions existing and that improvement must come as the result of a process of evolution rather than revolution, attention was first concentrated on the more serious accidents in an effort to reduce the number of fatalities, although no minor defect that could be remedied was neglected. The result of this policy is shown by a reduction of over 60 per cent. in the number killed and 10 per cent. in the number injured by failures of locomotive boilers and their appurtenances during the fiscal year ending June 30, 1913, as compared with the preceding year.

The practice of conducting a rigid, searching investigation of all accidents sufficiently serious to justify a report, with the sole object in view of determining the exact cause and having the proper remedy applied, has done much to reduce the list of casualties. The knowledge that such an investigation will follow every accident is an incentive to the railroad companies to maintain their equipment so that its condition can not be shown to have caused accidents, and is also an incentive to the employees to perform their work in the most efficient and careful manner. Therefore, we have followed the policy of investigating every accident reported to this division. The investigation of accidents by government inspectors whose only object is to promote safety, and who are therefore impartial, has directed attention to conditions which previously have been overlooked or ignored.

The period since the law became effective has been too brief to permit a comparison to be made which will accurately show its value. It is believed, however, that the following comparison of some of the most serious as well as some of the most frequent accidents during the first and last quarters of the fiscal year ending June 30, 1913, fairly represents the benefits which result from government supervision over the condition of locomotive boilers and their appurtenances.

	Accidents during first quarter, 1913.	Accidents during last quarter, 1913.
Crown-sheet failures.....	18	9
Water glasses bursting.....	36	16
Lubricator glasses bursting.....	11	6
Squirt-hose failures.....	161	64
Flue failures.....	15	11

A summary of the inspection work performed during the year shows the following:

Number of locomotives inspected.....	90,346
Number found defective.....	54,522
Number out of service.....	4,676
Number having pressure reduced to insure proper factor of safety.	472
Number having seams reinforced by welt plates to insure proper factor of safety.....	561
Number having the lowest reading of the waterglass raised to comply with the law.....	381



Number having the lowest gage cock raised to comply with the law.	172
Number strengthened by having braces of greater sectional area applied	281
Number requiring additional support of crown sheet.	147

It will thus be seen that during the year 6,690 locomotives were either held out of service for repairs or ordered changed and strengthened to conform to the requirements of the law.

The number of locomotives found defective as shown above, viz., 54,522, does not indicate that this number of locomotives was found to be in violation of the law, but they were found to contain defects which should be remedied before the locomotives were again placed in service. The number found in direct violation of the law is represented by the number ordered out of service. No formal appeal from the action of any district inspector has been filed during the year. This, in view of the vast amount of work performed and the number of locomotives on which repairs were ordered, shows that while the inspectors have been diligent they have also used discretion and good judgment in the enforcement of the law. It is believed that it also shows the existence of a spirit of co-operation and an earnest effort to comply with the requirements of the law on the part of a large majority of railroad officials.

Specifications for practically all locomotive boilers in service were filed within the time prescribed by the law, but the variation in design and the widely different methods of calculation followed by the various railroads has delayed the work of checking them. Very satisfactory progress is being made in this important work, and it will soon be possible to show accurately the stresses on each part of every locomotive boiler in service. The results obtained indicate that when the checking is complete it will be necessary in some instances to compare the data shown on the specification cards with actual measurements in order to insure the accuracy of the information furnished. Specifications are filed for all new locomotive boilers before they are put in service, and when repairs are made on boilers now in service which in any way affect their strength, the changes are reported on a suitable form; therefore our records are kept up to date.

Shortly after our inspectors were placed in the field they frequently advised that they were finding locomotives in service with serious defects, such as sharp or badly worn flanges, flat wheels, cracked or broken wheels, loose wheels or tires, thin or badly worn tires, excessive lateral motion in engine trucks, drivers, and trailers, broken frames, broken arch bars, broken springs, and other defects, all of which are a fruitful source of accidents and derailments, but which are not covered by the locomotive boiler inspection law, or any other law. In fact, it was found to be a common practice on some railroads to continue in service on their own line equipment which if offered in interchange by a connecting line would be refused on account of its defective condition.

Although this division has no legal authority to act in such cases, we believe that travelers and employees on railroads are entitled to all the protection against accidents that can be provided. Therefore our inspectors were instructed while making their regular inspections to note any defective conditions on locomotives which were apt to cause accidents, and when any were found to advise the railroad official in charge, and if proper repairs were not promptly made to wire the chief inspector, who would bring it to the attention of higher officials. During the past year 1,568 locomotives having defects of the above-mentioned character, 1,052 of which were defective wheels, have been reported to this division and to the railroad officials. These defects have been discovered by such casual inspection of the different parts of the locomotives as could be made while our inspectors were engaged in their regular work of inspecting locomotive boilers and their appurtenances as required by law. There can be no doubt, therefore, that many more would have been found had a more thorough inspection been made. It is extremely gratifying to be able to state that a large percentage of the railroad officials appreciate this action

on the part of our inspectors and take prompt action to remedy the defects to which their attention has been thus directed.

In some instances, however, railroad officials have objected to this division requesting repairs to defects not covered by the law, have advised us that we have no authority over such matters, and have failed to make the repairs, even though the defects were of a nature that might cause serious accidents. For this reason the provisions of section 6 of the locomotive-boiler inspection law should be made to apply to every part of locomotives and tenders, as well as to locomotive boilers and their appurtenances, so that our inspectors would have legal authority to require proper repairs to be made to any part of the locomotive or tender when it is found to be in an unsafe or improper condition for service.

It is respectfully recommended, therefore, that Congress be requested to enact necessary legislation to confer upon this division the authority to require repairs to be made to any part of a locomotive or tender when it is found to be in an unsafe or improper condition to operate in the service to which the same is put. Such an inspection would to a certain extent increase the work and responsibility of this division, but it would be a safeguard to travelers and employees upon railroads that would amply repay the effort, and as this division already has an organization of mechanical experts fully qualified to perform such work, a small increase in this force would enable us to conduct a very efficient locomotive inspection without increasing the cost beyond the maximum fixed by the locomotive-boiler inspection law.

#### PLAN FOR A UNIFORM FREIGHT RATE STRUCTURE AND METHOD OF STATING RATES.

W. B. Barr and E. E. Williamson, of Washington, D. C., have recently copyrighted an interesting plan for the simplification of railway freight rate tariffs by the establishment of a uniform rate structure which includes a novel method of stating rates and classifications by the use of a "Universal Freight Rate Base Sheet."

Briefly stated, the plan provides for the adoption of specific base rates between any two points, to be determined with regard to transportation and commercial conditions in various sections of the country, and the classification of rates on the various commodities as percentages above or below the base rate, the relations to be the same throughout the United States.

The Universal Freight Rate Base Sheet consists of tables of all base rates in cents per 100 pounds from 10 cents up to \$3.00, arranged in vertical columns and printed in red, with the percentages of these rates, printed in black, graduated up to 300 per cent. and down to 10 per cent., in parallel columns to the left and right, respectively, of the base rate column. These tables occupy three sheets each 16½ in. by 17½ in., containing 46 columns or classes, including the base rate.

The need for a uniform rate structure and the various features of the plan are described in a statement issued by the authors in part as follows:

"In the earlier stages of railway growth, when there were many small and independent lines, rates and classifications were made by almost as many traffic men as there were roads, and without any reference to a common unit. Since the enactment of the interstate commerce law, many of the numerous classifications have been consolidated, and a standard adopted for computing rates in certain territories.

"Notwithstanding this, the marvelous growth of commerce, and the rapid expansion of railway mileage, makes necessary, under the existing system of rate structures, a multiplicity of commodity tariffs and exceptions to classifications, with such variety of expression in all of them, that it leaves the layman

in a labyrinthian maze, and even the most competent traffic expert is often at his wits' end to interpret them. The one imperative need of commerce and transportation today, is uniformity and simplicity in the statement of rates.

"Heretofore thought has almost exclusively centered around a uniform classification, with practically no serious consideration given to a uniform rate structure to which it could be applied; hence the slow progress since 1890, in the matter of a uniform classification. After a most exhaustive study of the subject our judgment is that a uniform rate structure is a condition precedent to any successful effort to construct a uniform classification. Once a uniform rate structure is determined upon, a uniform classification applicable thereto would rapidly follow.

"A freight rate structure or schedule should logically be predicated upon a unit. A freight rate structure or schedule in its simplest form consists of a base rate as a unit, and classified ratings fixed on a percentage relation thereto. Our Universal Freight Rate Base Sheet is predicated on a base rate as a unit, with percentage relations thereto, being a uniform freight rate structure or schedule in its simplest form.

"The base rate between any two points is fixed with regard to the transportation and commercial conditions of each section in which located. The classified percentage ratings in their relation to any given base rate are the same throughout the United States. Thus 75 cents per 100 pounds may be the just and reasonable base rate for 1,000 miles in Official territory, 100 miles in Southern territory, and 200 miles in Western territory. But in each instance all the other classified percentage ratings bear a uniform relation to the base rate of 75 cents.

"The adoption of the Base Sheet means that the base rate or unit is the only rate published in a tariff (except as hereinafter explained) between any two given points. Rates other than base are computed as a percentage below or above base. By making the Base Sheet a part of each tariff it is only necessary to publish the base rate between any two given points. To ascertain the rates between any two given points other than base, first find the base rate and then refer to the Base Sheet for the rate set forth under the percentage rating assigned to the article in the classification.

"The Universal Freight Rate Base Sheet provides a rate structure or schedule to which a uniform classification can be applied. It anticipates the discarding of numerals and letters, such as are used in existing classifications, and substituting therefore ratings as base, or a percentage below or above base. The Base Sheet provides 46 classified ratings including base. As the base rate only is published (except as hereinafter explained) between any two given points, it is practical to state as classified ratings as many percentage relations of base as may be necessary. This liberal number of percentage ratings results in no complications, because the situation resolves itself into a simple proposition of indexing.

"Under the different existing rate structures, the number of class rates as indicated by numerals and letters is so limited as to be inadequate to express the rates under which the bulk of commerce actually moves. Hence a confusing list of exceptions to the existing classifications and hundreds of commodity rates are found to be necessary, thus creating a complex situation that is almost unbearable.

"The 46 classified percentage ratings of the Base Sheet afford such a flexibility of expression that the number of exceptions to the classification is reduced to a minimum. Inasmuch as there are in the several existing classification territories certain articles of commerce that are peculiar to each, a minimum number of exceptions to a uniform classification framed to govern the Base Sheet will still be necessary to take care of peculiar circumstances and conditions affecting them.

"It is conservatively estimated that under the facility of expression afforded by the Universal Freight Rate Base Sheet

governed by classified percentage ratings, the number of commodity rates now published can be reduced from 75 to 80 per cent., and a very large percentage of our commerce moves under a uniform classification.

"It will still be more convenient for the shipping public and the carriers, for the rates on the leading staples in commerce, among others grain, coal and coke, lumber, iron ore, pig iron, cotton and fertilizer, to be published in specific commodity tariffs, because rates thereon are usually grouped as to points of origin or points of destination or both.

"There being no uniform percentage relation between the various numeral and letter classes, under the present rate structures (except as published by the legislatures and railway commissions of a few states), much of the time of freight traffic officials and their rate staffs is taken up in an alinement of the various numeral and letter classes, whereas a great saving in this respect is afforded by the Universal Freight Rate Base Sheet, which automatically determines the percentage relation of all other classes, once the base is established between two given points.

"To illustrate: If 40 cents per 100 lbs. is fixed by the carriers as a just and reasonable base rate between two points, it is not necessary for traffic officials and their staff to spend time in the alinement of other classified rates, because 40 cents per 100 lbs. having been fixed as the base rate, the Universal Freight Rate Base Sheet, which would be a part of each tariff, indicates all the other classified rates in a percentage relation to the base rate of 40 cents.

"The first class rate from Ohio river crossings to Atlanta, Ga., is 98 cents per 100 lbs. Let us assume, for the purpose of illustration, that 98 cents is a just and reasonable base rate. Further, let us assume that the base rate from Atlanta, Ga., to some local point on the Southern Railway south of Atlanta, Ga., is 30 cents per 100 lbs. Forty per cent. of the base rate of 98 cents to Atlanta is 39 cents. Forty per cent. of the base rate of 30 cents from Atlanta is 12 cents. The sum of 39 cents and 12 cents is 51 cents. The sum of the base rate of 98 cents to Atlanta and the base rate of 30 cents from Atlanta is \$1.28, or stated differently, the through base rate from Ohio river crossings to such local point on the Southern Railway south of Atlanta is \$1.28.

"By referring to Sheet 2 of the Universal Freight Rate Base Sheet, it will be seen that 40 per cent. of the base rate of \$1.28 is 51 cents, which equals the sum of 40 per cent. of 98 cents and 40 per cent. of 30 cents. In other words, the percentage of the sum of any two base rates is equal to the sum of the same percentage of said two base rates, the Universal Freight Rate Base Sheet acting, so to speak, as an automatic adder.

"The base rate, being the unit, must be such a rate that the schedule of classified percentage ratings predicated thereon will be just and reasonable.

"It is believed that the first-class rates under the existing rate structures will afford a guide in determining the base rates."

TRAVELING IN KASHMIR.—There is as yet no railroad to the vale of Kashmir. Travelers who wish to get there have to travel a distance of about 200 miles from a point in the Punjab on the line of the Northwestern, either by a horse vehicle, known as a tonga, or by motor car. The cost of a round trip in the latter is about \$130, and the journey can be made in a day and a half, barring accidents. The traveler must pay \$13 for a seat in a tonga. If he does not make stops at night he can cover the distance in 36 or 38 hours, but for ordinary travelers the journey takes at least three or four days. The tongas are very uncomfortable. They can carry no baggage to speak of; that must be sent ahead to take a 15 day journey in slow bullock carts. Needless to say the vale of Kashmir is in a position of comparative seclusion.

## General News.

The Great Northern roundhouse at Maxbass, N. D., was destroyed by fire on December 15.

A new railroad Y. M. C. A. building on the Missouri Pacific at Bush, Ill., was opened on Thanksgiving day, and formally opened on December 3. The building cost \$19,000, and is the thirteenth building of this character on the lines of the Missouri Pacific-Iron Mountain system.

D. O. Ives, chairman of the Transportation Committee of the Boston Chamber of Commerce, and a well known former railroad traffic officer, is recommended by the commercial organizations of the six New England states as a candidate for a place on the Interstate Commerce Commission.

Electrification of the main line of the Pennsylvania from Philadelphia westward to Paoli has now progressed to the extent that the company has completed an experimental overhead structure for a distance of one mile. It is understood that the Philadelphia-Paoli electrification will be single phase.

A bill has been passed by the upper house of Congress to provide that suits brought against a railroad or a common carrier before either a state or a federal court may not be appealed to a higher court unless the amount involved is more than \$1,000. The bill was reported by the Senate Judiciary Committee and was adopted without debate.

T. J. Freeman, president of the International & Great Northern, is quoted as saying it will cost the road \$225,000 to \$250,000 to repair the damage caused by the recent flood. The Texas Railroad Commission has asked the roads affected by the floods to submit a detailed statement reporting the losses sustained and the damage done by the floods, with an estimate of the cost of repairs and replacements.

W. W. Ryder, for the past year at the head of the railway contract department of the Western Union Telegraph Company, has been appointed general manager of the Western division of that company with office at Chicago, succeeding T. P. Cook. Mr. Ryder was formerly and for 17 years, 1893-1910, superintendent of telegraph of the Chicago, Burlington & Quincy; and he later held a similar position on the New York Central Lines west of Buffalo.

The new shops of the Chicago & North Western at Clinton, Iowa, were formally opened on December 17. The railway management gave a reception at the shops to the public in the afternoon, and the Clinton Commercial Club gave a reception and dinner to the officers of the road in the evening. C. F. Terhune, secretary of the Club, was the toastmaster, and addresses were made by several citizens, and also by several officers of the road, including R. H. Aishton, vice-president in charge of operation. The dinner was an unusual one because of the cordial spirit of co-operation manifested by both the business men and the railway officers.

It is estimated in Chicago that the railroads are operating cars equivalent to five or six ordinary trains, with practically no remuneration, to handle the holiday tonnage of parcel post matter in and out of Chicago. The Post Office Department will have an increase for the year of about \$17,000,000 in its receipts, wholly attributable to the parcel post, and almost unburdened with any expense of transportation. Figures of the Chicago Post Office show that where from 130 to 140 tons of parcel post matter have been sent out daily for months, from 200 to 250 tons have been sent in the last few days. The Chicago office will handle about ten million packages for December, it is estimated, against three million last January. On this basis the country's shipments by parcel post for Christmas will exceed fifty million packages.

The report of Second Assistant Postmaster General Stewart, issued this week, indicates that the post office department expects to reduce the increased expenditures for railway car service by establishing railway terminal post offices and requiring the mail of publishers to be separated by routes. A large amount of additional car space already has been required on mail trains to make room for the parcel post. The extension

of the service caused an increase of \$451,072 in the annual expenditure for car rental from January 1 to November 29. Considerable space in the report is given to a discussion of the transportation of the periodical mail by fast freight. It is asserted that this method of transportation has been generally satisfactory to publishers. On the question of additional compensation for the transportation of the mails, it is promised that a report will be made to Congress on or before March 4.

### Safety-First in Earnest.

According to a Los Angeles paper, the campaign carried on by the officers of the Atchison, Topeka & Santa Fe, to promote "safety-first" and to induce employees to "Get the Safety Habit," was duly impressed on about 1,000 mechanics recently at San Bernardino, Cal., when it was announced that several men had been discharged for failure to observe the instructions to use the foot viaduct when crossing the switching yards.

### Signal Instruction on the North Western.

The Chicago & North Western has established a plan of signal instruction on its lines for the benefit of operating employees. A passenger coach, especially fitted up to conform to the needs of the man in charge, is utilized for the instruction work. One-half of the car is given over to a lecture room; at the other end are the quarters of the instructor, and a dark room and other facilities for the developing of pictures and making of lantern slides.

The instructor is supplied with a combination gas-electric stereopticon machine, and an oxyhydrogen gas generator, for use at points where electric power is not obtainable. The car also is fitted with both gas and electric lighting facilities. Twice a year the signal instruction car will cover the Chicago & North Western system, disseminating the latest signal information, advice and instructions among all operating employees. Stops are made at important points on each division. At each point lectures lasting about two hours are given, illustrated by stereopticon views taken on that particular division. The various signal or interlocking devices, positions and difficulties, every piece of unusual track and other conditions not immediately understood by average employees are thus brought before the men most vitally interested, and fully explained by the lecturer. Great interest is shown in this work by the employees. Everywhere the lectures are given they are well attended. C. G. Stecher, signal instructor, is in charge of the work, and the signal instruction car. He has recently been giving lectures in the old Wells street terminal yards, Chicago.

### Progress in St. Paul Electrification.

The Chicago, Milwaukee & St. Paul has decided to proceed with a part of its elaborate electrification project. It will electrify one engine district, Deer Lodge, Mont., to Three Forks crossing in the Rocky mountains; 113 miles of line. With sidings and yards there will be a total of 168 miles of track. Direct current will be used, 2,400 volts, with overhead trolley construction. Wooden poles and mast arms to be used on tangents, and span wires over curves. In yards steel poles and overhead bridge trolley supports will be used. The power will be received from the Great Falls Power Company, to be transmitted at 100,000 volts and transformed to the trolley voltage in five substations ranging in capacity from 3,000 to 4,500 kilowatts, depending on the grade of the section to be served. The locomotives are to be of the same type as those used on the Butte, Anaconda & Pacific, with modifications to meet the Milwaukee's conditions.

### Brevity the Soul of Wit.

One of the officers of this company recently dictated a telegram of 296 words. An efficient and careful stenographer, with an eye to the company's interests "blue penciled" the message and succeeded in concisely but fully covering the subject in just 91, or a saving of 205 words. The telegraph wires are to be used of course. That is what the service is for, but a mere consideration of your own time, the time of the operators and of the company will force the conclusion that many of us often unconsciously

run to words. Not one telegram in ten sent over the company's wires but what could be comfortably scaled down.—*Sunset Central Bulletin*.

#### Courtesy in Correspondence.

We are constantly urged to be courteous to our patrons in our personal dealings. It is just as important that we be courteous in our correspondence. Every letter, regardless of its tenor, contents, or writer, is entitled to a prompt and courteous acknowledgment. It is often necessary to refer it to some other authority for information or instruction. This entails delay and sometimes is overlooked. In the meantime, the writer is in ignorance of the cause of the delay and blames the railroad. Hence, it is important that letters from patrons be promptly acknowledged if possible the day they are received. This is an almost invariable rule of business houses, certainly of the successful ones.

This leads up to correspondence among ourselves. We are prone to judge for ourselves as to the necessity for a prompt reply, overlooking the fact that the "man on the ground" is the best judge of this. It also depends too frequently on one who signs the communication. If, as should be the case, the same attention were given to a communication from the humblest employees as is given to a communication from the man "higher up," the man "higher up" would have more time to give to more important matters. We are also prone to judge for ourselves and disregard a request to "answer by wire," "phone answer," "rush answer," etc. Such requests should be complied with. Such a request is in nearly every case made in the interests of the company, either to satisfy patrons or to secure traffic, and the man "on the ground" is the best judge. Many a car of freight has been lost and many a patron alienated because an agent or other traffic representative could not get the information he asked for by the time he wanted it, and which he should have been given promptly and properly. By working together, we work as one and the company will get the result.—*Sunset Central Bulletin*.

#### The Traffic Club of New York.

The regular monthly meeting of the New York Traffic Club will be held at the Waldorf-Astoria, on December 30. The subject for discussion at the meeting will be Current Transportation Problems. There will be brief addresses by J. S. Marvin, general traffic manager, Automobile Chamber of Commerce; J. C. Lincoln, manager of the traffic bureau, Merchants Association of New York; Paul Gottheil, senior member of the firm of Funch, Edye & Company, steamship agents, and Nat Duke, assistant freight traffic manager of the D. L. & W. As an entertainment feature, H. C. Hooker, of the Erie Railroad, has consented to sing one or more selections. The club has also secured the Gwent Welsh male singers, with George F. Davies as conductor.

The annual dinner of the Traffic Club will be held at the Waldorf-Astoria on February 11.

#### A Stockholders' Association.

There have been recently various movements looking toward the formation of a stockholders' protective union or association which would, if necessary, hire counsel and protect the small stockholders' interest from hostile legislation, unfair decision of railroad commissions, etc. Dr. Thomas Dixon, of Brooklyn, has started to organize the stockholders of the Pennsylvania Railroad, and Herbert A. Scheffel introduced recently in the New York Chamber of Commerce a resolution preparing the way for the organization of a general stockholders' protective union. In an interview printed in the *Wall Street Journal* recently Mr. Scheffel is quoted in part as follows:

"I am much pleased at the interest everywhere shown in the resolution I offered at the Chamber of Commerce meeting, suggesting that stockholders be unionized to protect their holdings against constant political attack.

"Properly undertaken and conducted, such an organization would draw to itself and include in its membership all who have any property interest in the country and so counterbalance the activity which finds expression through the unionized labor

organization and socialistic societies which are united against capital.

"The trend of this latter movement, starting in with a campaign against big business, has gotten down to a point where prosperity is considered a crime and anyone owning property of any kind is viewed with distrust. This is illustrated in one of the letters which I have received, in which the writer says:

"Actually, I have come to feel that somehow, by reason of being a stockholder, I no longer have any rights as a citizen or reason to expect consideration of my interests at the hands of the lawmakers. There is certainly injustice in such a state of affairs that must ultimately react to the injury of the country in general."

"I do not believe the average man realizes what the end of this movement, attacking capital and securities, will result in. The business of the country is founded upon capital and if the supply of this is withdrawn, business must come to a halt and the means of subsistence of a large part of our people would thus be destroyed.

"Today all new enterprises are practically at a standstill. The condition of the security market affects millions of people—not only the bond and stockholders. It goes to the bottom of society and affects a great army of poor people, who are the beneficiaries of insurance policies, for instance, because the welfare of the insurance companies depends upon the value of the securities which they hold.

"Unorganized as the stockholders are at present, they are powerless to protect themselves and their securities have become the target of socialists, yellow publications, and the politicians. But if these same stockholders and property owners were organized, the business and industrial interests of the country would lead all others and this influence would benefit every member of the community.

"A movement of a similar character was undertaken once before, when the country was threatened with a crisis. One stockholder writes me as follows of this occasion:

"When McKinley was elected President of the United States in 1896, stockholders of railroads, banks and industrial companies were all aroused to take an active part in that campaign. They were so eloquently advised that they must do it, that they did do it. There was one result from this and that was a victory for the business interests of the country. The present situation seems to be approaching a similar crisis unless these selfsame people begin to realize their danger and take an active part in a campaign for their business rights."

"For some years we have been living under a government of agitation. One agitation has followed another, one so-called reform close upon another. Wild theories have been introduced, with pressure to have them tried out.

"It is certainly time for the sound thinking people of the country to unite against these destructive operations. I am very hopeful that much good will come out of my suggestion and believe that in some form an organization will be effected in the near future.

"Today one of the largest corporations in the country sent word to me, asking whether an association of the kind suggested had been formed, as it wished to send membership blanks to its stockholders throughout the country, to give them an opportunity to enroll."

#### Chicago Terminal Negotiations.

Negotiations between the railways that have asked ordinances for the new Union Station at Chicago and the City Council Committee on railway terminals have been going on during the past week, but with little progress toward an agreement. The city's representatives have insisted on certain terms of compensation for streets to be vacated, which they have varied from day to day, ranging from \$2,000,000 to approximately \$8,000,000 and a large number of other conditions, including payment for expensive street improvements and viaducts, which the railways have refused to accept. At a meeting on Saturday night, December 20, which was attended by Vice-President Turner, of the Pennsylvania lines, President Miller of the Chicago, Burlington & Quincy and President Earling of the Chicago, Milwaukee & St. Paul, the roads announced that they would not accept the ordinance with the conditions which the city had imposed and negotiations were temporarily broken off. Later it was decided to hold another meeting on Monday. The council committee has endeavored to settle the matter before January

1 for fear that the new state public utilities commission will take jurisdiction after that date.

On Monday of this week the railways sent a letter to the council committee, asking postponement of further consideration of the Union Station ordinances, and promising to present the railways' position as soon as possible.

#### International Railway General Foremen's Association.

At a meeting of the Executive Committee, held at the Hotel Sherman, Chicago, December 9, 1913, it was decided to hold the 1914 convention July 14 to 17 at the Hotel Sherman, Chicago. A campaign has been started to build up the membership and make the association the strongest of its kind in the country. The following papers have been selected for the 1914 convention program: Enginehouse Efficiency, by W. Smith, Chicago & Northwestern; Cylinders, Pistons, Crossheads, Guides and Valves, by J. T. Mullin, Lake Erie & Western; The Practice and Methods of Maintenance and Repairs to the Air Brake and Its Appurtenances, by C. M. Newman, Atlantic Coast Line; Autogenous Welding, by C. L. Dickert, Central of Georgia; Subsidiary Paper No. 1, The Taylor System, by W. W. Scott, Delaware, Lackawanna & Western; Subsidiary Paper No. 2, Railroadng at a High Altitude, by J. W. Scott, Southern Railways of Peru.

#### The American Society of Mechanical Engineers.

On January 9 the American Society of Mechanical Engineers will hold a meeting jointly with the American Institute of Electrical Engineers and the New York section of the American Electro Chemical Society, in the Engineering Societies building, New York. The discussion for the evening will be: The Power Problem in the Electrolytic Deposition of Metals. Dr. C. O. Mailloux, president of the American Institute of Electrical Engineers, will preside. Papers will be presented by Lawrence Addicks, A. E. S., on The Limitations of the Problem; by H. E. Longwell, A. S. M. E., on The Mechanical Side of the Problem, and by F. D. Newbury, A. I. E. E., on the Electrical Side of the Problem. These papers will be illustrated.

#### MEETINGS AND CONVENTIONS.

*The following list gives names of secretaries, dates of next or regular meetings, and places of meeting.*

- AIR BRAKE ASSOCIATION.—F. M. Nellis, 53 State St., Boston, Mass. Next convention, May, 1914.
- AMERICAN ASSOCIATION OF DEMURPAGE OFFICERS.—A. G. Thomason, Boston, Mass. Convention, May 19, 1914, St. Louis.
- AMERICAN ASSOCIATION OF GENERAL PASSENGER AND TICKET AGENTS.—W. C. Hope, New York.
- AMERICAN ASSOCIATION OF FREIGHT AGENTS.—R. O. Wells, East St. Louis, Ill. Next convention, April 21, Houston, Tex.
- AMERICAN ASSOCIATION OF RAILROAD SUPERINTENDENTS.—E. H. Hartman, St. Louis, Mo.; 3d Thursday and Friday in May.
- AMERICAN ELECTRIC RAILWAY ASSOCIATION.—E. B. Burritt, 29 W. 39th St., New York. Mid-year conference, New York, January 29, 30, 31.
- AMERICAN ELECTRIC RAILWAY MANUFACTURERS' ASSOC.—H. G. McConaughy, 165 Broadway, New York. Meetings with Am. Elec. Ry. Assoc.
- AMERICAN RAILWAY ASSOCIATION.—W. F. Allen, 75 Church St., New York.
- AMERICAN RAILWAY BRIDGE AND BUILDING ASSOCIATION.—C. A. Lichtig, C. & N. W., Chicago. Next convention, October 20-22, 1914, Los Angeles, Cal.
- AMERICAN RAILWAY ENGINEERING ASSOCIATION.—E. H. Fritch, 900 S. Michigan Ave., Chicago. Next convention, March 17-20, Chicago.
- AMERICAN RAILWAY MASTER MECHANICS' ASSOCIATION.—J. W. Taylor, Karpen building, Chicago. June 15-17, Atlantic City, N. J.
- AMERICAN RAILWAY TOOL FOREMEN'S ASSOCIATION.—A. R. Davis, Central of Georgia, Macon, Ga.
- AMERICAN SOCIETY FOR TESTING MATERIALS.—Prof. E. Marburg, University of Pennsylvania, Philadelphia, Pa.
- AMERICAN SOCIETY OF CIVIL ENGINEERS.—C. W. Hunt, 220 West 57th St., New York; 1st and 3d Wed., except June and August, New York.
- AMERICAN SOCIETY OF ENGINEERING CONTRACTORS.—J. R. Wenlinger, 11 Broadway, New York; 2d Tuesday of each month, New York.
- AMERICAN SOCIETY OF MECHANICAL ENGINEERS.—Calvin W. Rice, 29 W. 39th St., New York.
- AMERICAN WOOD PRESERVERS' ASSOCIATION.—F. J. Angier, B. & O., Baltimore, Md. Next convention, January 20-22, 1914, New Orleans, La.
- ASSOCIATION OF AMERICAN RAILWAY ACCOUNTING OFFICERS.—C. G. Phillips, Highland Park, Ill. Annual meeting, June 24, Minneapolis, Minn.
- ASSOCIATION OF RAILWAY CLAIM AGENTS.—C. W. Egan, B. & O., Baltimore, Md. Next convention, May, 1914, St. Paul, Minn.
- ASSOCIATION OF RAILWAY ELECTRICAL ENGINEERS.—Jos. A. Andreucetti, C. & N. W. Ry., Chicago.
- ASSOCIATION OF RAILWAY TELEGRAPH SUPERINTENDENTS.—P. W. Drew, 112 West Adams St., Chicago. Next convention, May 20-23, New Orleans, La.
- ASSOCIATION OF TRANSPORTATION AND CAR ACCOUNTING OFFICERS.—G. P. Conard, 75 Church St., New York.
- ASSOCIATION OF WATER LINE ACCOUNTING OFFICERS.—W. R. Evans, Chamber of Commerce, Buffalo, N. Y.
- BRIDGE AND BUILDING SUPPLY MEN'S ASSOCIATION.—L. D. Mitchell, Detroit Graphite Co., Detroit, Mich. Meeting with American Railway Bridge and Building Association.
- CANADIAN RAILWAY CLUB.—James Powell, Grand Trunk Ry., Montreal, Que.; 2d Tuesday in month, except June, July and August, Montreal.
- CANADIAN SOCIETY OF CIVIL ENGINEERS.—Clement H. McLeod, 413 Dorchester St., Montreal, Que.; Thursday, Montreal.
- CAR FOREMEN'S ASSOCIATION OF CHICAGO.—Aaron Kline, 841 North 50th Court, Chicago; 2d Monday in month, Chicago.
- CENTRAL RAILWAY CLUB.—H. D. Vought, 95 Liberty St., New York; 2d Thurs. in Jan. and 2d. Fri. in March, May, Sept., Nov., Buffalo, N. Y.
- CIVIL ENGINEERS' SOCIETY OF ST. PAUL.—L. S. Pomeroy, Old State Capitol building, St. Paul, Minn.; 2d Monday, except June, July, August and September, St. Paul.
- ENGINEERS' SOCIETY OF PENNSYLVANIA.—E. R. Dasher, Box 704, Harrisburg, Pa.; 1st Monday after second Saturday, Harrisburg, Pa.
- ENGINEERS' SOCIETY OF WESTERN PENNSYLVANIA.—E. H. Hiles, Oliver building, Pittsburgh; 1st and 3d Tuesday, Pittsburgh, Pa.
- FREIGHT CLAIM ASSOCIATION.—Warren P. Taylor, Richmond, Va. Next convention, May 20-22, Galveston, Tex.
- GENERAL SUPERINTENDENTS' ASSOCIATION OF CHICAGO.—E. S. Koller, 226 W. Adams St., Chicago; Wed. preceding 3d Thurs., Chicago.
- INTERNATIONAL RAILWAY CONGRESS.—Executive Committee, 11, rue de Louvain, Brussels, Belgium. Convention, 1915, Berlin.
- INTERNATIONAL RAILWAY FUEL ASSOCIATION.—C. G. Hall, 922 McCormick building, Chicago. Annual convention, May 18-22, Chicago.
- INTERNATIONAL RAILWAY GENERAL FOREMEN'S ASSOCIATION.—Wm. Hall, 829 West Broadway, Winona, Minn., Next convention, July, Chicago.
- INTERNATIONAL RAILROAD MASTER BLACKSMITHS' ASSOCIATION.—A. L. Woodworth, Lima, Ohio. Next convention, third Tuesday in August.
- MAINTENANCE OF WAY & MASTER PAINTERS' ASSOCIATION OF THE UNITED STATES AND CANADA.—T. I. Goodwin, C. R. I. & P., Eldon, Mo. Next convention, November 17-19, 1914, Detroit, Mich.
- MASTER BOILER MAKERS' ASSOCIATION.—Harry D. Vought, 95 Liberty St., New York. Next annual meeting, May 26-29, Hotel Waldron, Philadelphia.
- MASTER CAR BUILDERS' ASSOCIATION.—J. W. Taylor, Karpen building, Chicago. June 10-12, Atlantic City, N. J.
- MASTER CAR & LOCOMOTIVE PAINTERS' ASSOC. OF U. S. AND CANADA.—A. P. Dane, B. & M., Reading, Mass.
- NATIONAL RAILWAY APPLIANCE ASSOC.—Bruce V. Crandall, 537 So. Dearborn St., Chicago. Meetings with Am. Ry. Eng. Assoc.
- NEW ENGLAND RAILROAD CLUB.—W. E. Cade, Jr., 683 Atlantic Ave., Boston, Mass.; 2d Tuesday in month, except June, July, Aug. and Sept., Boston.
- NEW YORK RAILROAD CLUB.—H. D. Vought, 95 Liberty St., New York; 3rd Friday in month, except June, July and August, New York.
- NORTHERN RAILROAD CLUB.—C. L. Kennedy, C. M. & St. P., Duluth, Minn.; 4th Saturday, Duluth.
- PEORIA ASSOCIATION OF RAILROAD OFFICERS.—M. W. Rotchford, Union Station, Peoria; 2d Thursday.
- RAILROAD CLUB OF KANSAS CITY.—C. Manlove, 1008 Walnut St., Kansas City, Mo.; 3d Friday in month, Kansas City.
- RAILWAY BUSINESS ASSOCIATION.—Frank W. Noxon, 30 Church St., New York.
- RAILWAY CLUB OF PITTSBURGH.—J. B. Anderson, Penna. R. R., Pittsburgh, Pa.; 4th Friday in month, except June, July and August, Pittsburgh.
- RAILWAY ELECTRICAL SUPPLY MANUFACTURERS' ASSOC.—J. Scribner, 1021 Monadnock Block, Chicago. Meetings with Assoc. Ry. Elec. Engrs.
- RAILWAY FIRE PROTECTION ASSOCIATION.—C. B. Edwards, Mobile & Ohio, Mobile, Ala.
- RAILWAY GARDENING ASSOCIATION.—J. S. Butterfield, Lee's Summit, Mo.
- RAILWAY DEVELOPMENT ASSOCIATION.—W. Nicholson, Kansas City Southern, Kansas City, Mo.
- RAILWAY SIGNAL ASSOCIATION.—C. C. Rosenberg, Bethlehem, Pa.
- RAILWAY STOREKEEPERS' ASSOCIATION.—J. P. Murphy, Box C, Collinwood, Ohio.
- RAILWAY SUPPLY MANUFACTURERS' ASSOC.—J. D. Conway, 2135 Oliver bldg., Pittsburgh, Pa. Meetings with M. M. and M. C. B. Assocs.
- RAILWAY TEL. & TEL. APPLIANCE ASSOC.—W. E. Harkness, 284 Pearl St., New York. Meetings with Assoc. of Ry. Teleg. Sups.
- RICHMOND RAILROAD CLUB.—F. O. Robinson, Richmond, Va.; 2d Monday except June, July and August.
- ROADMASTERS' AND MAINTENANCE OF WAY ASSOCIATION.—L. C. Ryan, C. & N. W., Sterling, Ill. Next convention, September 8-10, 1914, Chicago.
- ST. LOUIS RAILWAY CLUB.—B. W. Frauenthal, Union Station, St. Louis, Mo.; 2d Friday in month, except June, July and Aug., St. Louis.
- SIGNAL APPLIANCE ASSOCIATION.—F. W. Edmonds, 3868 Park Ave., New York. Meeting with annual convention Railway Signal Association.
- SOCIETY OF RAILWAY FINANCIAL OFFICERS.—C. Nyquist, La Salle St. Station, Chicago.
- SOUTHERN ASSOCIATION OF CAR SERVICE OFFICERS.—E. W. Sandwich, A. & W. P. Ry., Montgomery, Ala.
- SOUTHERN & SOUTHWESTERN RAILWAY CLUB.—A. J. Merrill, Grant bldg., Atlanta, Ga.; 3d Thurs., Jan., March, May, July, Sept., Nov., Atlanta.
- TOLEDO TRANSPORTATION CLUB.—J. G. Macomber, Woolson Spice Co., Toledo, Ohio; 1st Saturday, Toledo.
- TRACK SUPPLY ASSOCIATION.—W. C. Kidd, Ramapo Iron Works, Hillsburn, N. Y. Meetings with Roadmasters' and Maintenance of Way Association.
- TRAFFIC CLUB OF CHICAGO.—W. H. Wharton, La Salle Hotel, Chicago.
- TRAFFIC CLUB OF NEW YORK.—C. A. Swope, 290 Broadway, New York; last Tuesday in month, except June, July and August, New York.
- TRAFFIC CLUB OF PITTSBURGH.—D. L. Wells, Erie, Pittsburgh, Pa.; meetings monthly, Pittsburgh.
- TRAFFIC CLUB OF ST. LOUIS.—A. F. Versen, Mercantile Library building, St. Louis, Mo. Annual meeting in November. Noontday meetings October to May.
- TRAIN DESPATCHERS' ASSOCIATION OF AMERICA.—J. F. Mackie, 7122 Stewart Ave., Chicago. Next convention, June 16, Jacksonville, Fla.
- TRANSPORTATION CLUB OF BUFFALO.—J. M. Sells, Buffalo; first Saturday after first Wednesday.
- TRANSPORTATION CLUB OF DETROIT.—W. R. Hurley, L. S. & M. S., Detroit, Mich.; meetings monthly.
- TRAVELING ENGINEERS' ASSOCIATION.—W. O. Thompson, N. Y. C. & H. R., East Buffalo, N. Y. Next meeting, Chicago.
- UTAH SOCIETY OF ENGINEERS.—Fred D. Ulmer, Oregon Short Line, Salt Lake City, Utah; 3d Friday of each month, except July and August.
- WESTERN CANADA RAILWAY CLUB.—W. H. Rosevear, P. O. Box 1707, Winnipeg, Man.; 2d Monday, except June, July and August, Winnipeg.
- WESTERN RAILWAY CLUB.—J. W. Taylor, Karpen building, Chicago; 3d Tuesday of each month, except June, July and August.
- WESTERN SOCIETY OF ENGINEERS.—J. H. Warder, 1735 Monadnock Block, Chicago; 1st Monday in month, except July and August, Chicago.

## Traffic News.

The amount of grain passing through Buffalo during the navigation season just closed was 192,000,000 bushels, an increase of 25,000,000 over last year. The previous high record was 221,000,000 in 1898. Of this year's total 22,000,000 was Canadian grain.

"Script," a substitute for mileage tickets, used interchangeably on the railways of California, is to be made available also on the principal electric roads. The admission of the electric lines to the fold of the script roads was in response to an application made by a number of electric lines. The script is issued in booklets of the denominations of \$30 and \$90, and on the use of all the script, which is good for rail or stage line travel, the user is entitled to rebates of five or ten mills a mile, depending on whether the maximum fare is three or four cents a mile.

### A British View of the Panama Canal.

The significance of the Isthmian route, as we have suggested, can only be partially indicated at present by a comparison of statistics. The tolls factor, when it is finally decided—and we have not abandoned hope of better economic arrangements as the result of arbitration proceedings—will have an important bearing on the competing claims of the Panama and Suez Canal routes for trade in the zone that is approximately equidistant from British ports, or in that which is relatively nearer via Panama, but may be considerably cheaper via Suez. For the whole of Asia, and the greater part of Australasia, the Panama Canal offers no advantage (to the Thames trade). New Zealand is brought three days nearer to us, and some portions of Polynesia from five to ten days nearer; but the reduction of time may of course be very much more than offset by the augmented Canal dues. The saving is actual as well as relative only when the routes to the west coasts of North and South America are examined. Compared with voyages by the Straits of Magellan from London to any part of the American continental system, the saving of time by the Canal ranges from a week to almost three weeks. These are important figures. They appear to offer an immense stimulus to British shipping. But the appearance may be deceptive if the British shipowner is faced with Canal dues from which his American competitor is to be relieved. The exclusion of foreign competition from the American coasting trade will be complete, and it is not improbable that, by elastic interpretations of the law, the privileges of the American coaster may be stretched to cover a great part of what we should regard as deep-sea trading. The handicap with which our South American and West Canadian and Puget Sound trade is threatened renders it necessary that the British Foreign Office should continue with imperturbable courtesy to press for an impartial review of the circumstances under which American politicians are proposing to confer special privileges on their own trade for which the rest of the trading world will be heavily penalized.—*Manchester Guardian*.

### The Railway Mail Service.

If you can imagine what it means to know the exact location of some ten thousand postoffices, to know by what railroad they are reached, and by which of these roads a letter will reach them quickest; through what junction points it must travel, and a hundred and one other things; and then to be able to throw letters into a half hundred pigeon-holes, each pigeon-hole representing a certain locality, and each letter going into the right pigeon-hole, at the rate of a hundred or more a minute, the while the train is thundering along at a forty or fifty mile gait, then you can grasp what it means to be a railway mail clerk.

It requires some 17,000 clerks to man the 3,400 railroad postoffices in the United States. The clerks must constantly study and memorize thousands of new postoffices, and the quickest way of reaching them. Out of every 10,000 pieces of mail handled by the railway mail service last year 9,997 were handled correctly.

Each clerk must undergo an average of about three examinations a year. The department has books printed giving full data about each postoffice in a given territory, and showing the system of distribution of mail so as to reach each one of them. The

clerk must memorize all these, usually for all the postoffices in a given state at a time. Then he makes out a card for each postoffice, on the front of which there is the postoffice name and on the back the routing particulars. He buys himself a little case of pigeon-holes to correspond, except in dimensions, to the cases in the postal car. This little case contains 288 holes. He labels each hole. Then he must take the cards he has made out, and throw each card into its proper pigeon-hole. Not only must he learn to do it accurately, but rapidly as well. After he has satisfied himself with his proficiency in distributing these cards he goes before the inspectors and distributes the cards in their presence, being timed for speed and checked up for accuracy.

In each of these examinations the clerk must "throw" about a thousand cards, and he gets so many points off for each error and so many off for each minute above the standard it requires to "throw" a given number of cards. A clerk running from Washington to Greensboro, N. C., will, in the course of a few years, be required to pass an examination on the 2,500 postoffices in Virginia, the 1,800 in North Carolina, the 1,300 in Alabama, the 1,300 in Georgia, and those of three or four other states as well. Then, too, he must know in what package to tie every letter addressed to a street number in every one of the important cities like Washington, Baltimore, Philadelphia, or New York. Some of the clerks will correctly pigeon-hole 9,999 out of every 10,000.

The real secret of the efficiency of the mail service of the United States is due mainly to the railway postal clerk. When a person mails a letter in Washington for St. Louis, he can depend upon it that ninety-nine times out of a hundred his letter will reach the addressee on the first delivery from the first train into St. Louis from Washington after the letter was mailed. The Washington office makes up the St. Louis mail into bags. When they are on the last leg of the journey (from Indianapolis) the railway postal clerks empty their contents on the distributing tables and begin the work of throwing each piece into its proper pigeon-hole. A letter addressed to a certain number on Olive street goes to a certain carrier at the main office, and a letter to a suburban address goes to a certain carrier from a lettered station. The old system of carrying all mail from the city of origin to the city of destination without distribution according to streets would swamp the postoffices. The mail would have to be assorted piece by piece in the postoffice and the hour of delivery delayed greatly.—*Buffalo Commercial*.

### INTERSTATE COMMERCE COMMISSION.

Hon. Judson C. Clements, of Georgia, was on December 23 renominated as a member of the Interstate Commerce Commission for another term of six years, and the nomination was confirmed by the Senate on the same day. Mr. Clements has been a member of the commission since 1892.

Commissioner Harlan held a hearing at Chicago on December 18 and 19, to consider the readjustment of rates from eastern points to Iowa in accordance with a recent decision of the commission.

The commission has suspended from December 15 to April 14 schedules in a Florida East Coast tariff proposed to effect increases in rates on tomatoes, in carloads, from Jacksonville, Fla., when from beyond, to various points west of the Mississippi river.

The commission has further suspended from December 16 to June 16, schedules in tariffs of F. A. Leland and Eugene Morris, which proposed increased rates on packing house products in carloads from Mason City, Iowa, to points in Arkansas and Texas.

The standard forms of blanks for freight claims which were adopted this year by the Freight Claim Association, have been informally approved by the Interstate Commerce Commission. This blank was described in the *Railway Age Gazette*, August 22, page 341.

The commission has suspended from December 10 to April 9, an item in a Chicago, Burlington & Quincy tariff which proposed to prohibit interchange switching between industries located on the tracks of the Chicago, Burlington & Quincy and

track connection with the Rock Island Southern at Galesburg, Ill.

The commission has further suspended from December 30 to June 30, a Kanawha & Michigan tariff which proposed to increase rates on bituminous coal, in carloads, from mines in Kentucky and West Virginia to Milwaukee, Wis., via the Grand Trunk and car ferry across Lake Michigan for delivery beyond Milwaukee.

The commission has further suspended from December 18 to June 18, schedules in tariffs of the Illinois Central, which proposed to cancel proportional rates on grain and grain products in carloads, in connection with the Illinois Central from St. Louis, Mo., East St. Louis, Madison and certain other Illinois points to New York City and other eastern points.

The commission is to hold a hearing on January 22, upon the question of the proposed amendments or additions to the commission's regulations governing the transportation of explosives and other dangerous articles. Persons who desire to suggest changes should submit them at once to Col. B. W. Dunn, chief inspector of the bureau for safe transportation of explosives, as well as to the commission.

The commission has suspended to April 14 tariffs of the Pennsylvania Railroad, the Northern Central, the Philadelphia, Baltimore & Washington, and the West Jersey & Seashore, which proposed an increase of 15 cents per net ton in the commodity rates on stone from various points on lines of the Pennsylvania railroad and its connections in Maryland, Pennsylvania and Delaware to points in Delaware and Maryland.

The commission has further suspended from December to June 30 certain schedules in tariffs of Eugene Morris and W. H. Hosmer, which proposed to increase rates on soda crystals, bicarbonate of soda, bisulphate of soda, sal soda, silicate of soda, sulphate of soda, soda ash, caustic soda, sulphide of soda and sodium aluminum sulphate, in carloads, from Wyandotte and Detroit, Mich., and other points in Central Freight Association territory, to Canadian points.

#### Reduced New Haven Commutation Fares.

The commission in a supplemental order issued in connection with the New York commutation rate case has instructed the New York, New Haven & Hartford to establish before January 15 rates not in excess of the following for 60-ride monthly commutation tickets to New York and return; from Greenwich, \$8.65; Cos Cob, \$9.15; Riverside, \$9.25; Sound Beach, \$9.65, and Stamford, \$10.25. All of these points are in Connecticut.

#### Reparation Awarded.

*George A. Lee Company v. Illinois Central. Opinion by the commission:*

The complainant shipped a mixed carload of incubators and brooders from Omaha to Memphis, Tenn., and charges were collected at the second class rate of 67 cents per hundred pounds. The commission finds that the rate charged should not have exceeded the third class rate of 47 cents, with a minimum of 18,000 lbs., for a standard 36 ft. car. (28 I. C. C., 515.)

#### Springfield, Ill. Awarded 113 Per Cent. Group Rates.

*Springfield Commercial Association of Springfield, Ill., v. Pennsylvania Railroad, et al. Opinion by Commissioner Prouty:*

Complaint is made that since Peoria, Ill., takes 110 per cent. of the New York-Chicago rates on traffic to and from the east, while Springfield, Ill., is in 117 per cent. territory there is a serious handicap laid upon the industries of Springfield, and it is insisted that Springfield should be placed in the Peoria group. Springfield at present is in the St. Louis group, although the distance to it from New York is about 60 miles less than to St. Louis. The commission finds that there is an actual burden placed upon the industry of Springfield, and holds that since the percentage rates are based mainly on distance the rates to Springfield should not exceed 113 per cent. of the New York-Chicago rates. (28 I. C. C., 511.)

#### Scrap Iron Rates.

*Report by Commissioner Prouty:*

It is proposed to increase scrap iron rates between Chicago and other points and Racine, Milwaukee, Wis., and other points from 60 cents per gross ton to 70 cents. The commission finds that in comparison with the rates on sheet iron, steel rails, ingots, coke and coal, etc., between these points and the rates on scrap iron between St. Paul and Chicago that a rate of 70 cents is not justified. A rate not to exceed 3 cents per 100 lb. will be allowed for the future. (28 I. C. C., 525.)

#### Complaint Dismissed.

*Klauer Manufacturing Company v. Atchison, Topeka & Santa Fe. Opinion by Commissioner Clements:*

The commission finds that the present ratings on corrugated iron and steel culverts in western classification No. 51 are not unreasonable. Classification, from its varied nature and use, cannot be so minute as to do mathematically exact justice to every variety of commerce that may move. The carriers endeavored to give culverts ratings which would fit the general situation presented. In the absence of evidence of unreasonableness or of undue discrimination it is sufficient that the ratings fixed are satisfactory to culvert manufacturers in general. (28 I. C. C., 508.)

#### Massachusetts-Maine Wool Rates.

*Opinion by Commissioner Prouty:*

It is proposed to increase the rate on wool in any quantity from Lawrence, Mass., to Lewiston, Me., from 12½ to 15 cents per 100 lb. At the present time the rate from Boston to Skowhegan is 17½ cents, while that from Lawrence is 20 cents. The rate from both Boston and Lawrence to Lewiston is 12½ cents per 100 lb. The proposed rate of 15 cents is equal to fifth class rates. The commission finds, therefore, that the respondents have justified this increase in view of these facts and the fact that in previous cases it has decided that eastern wool should be classified l. c. l., first class; c. l., third class, and when scoured c. l., second class. (28 I. C. C., 397.)

#### Rates on Coal to Milwaukee and Other Wisconsin Points.

*Supplemental report by Commissioner Meyer:*

In the original case, in which the delivering line involved was the Pere Marquette and car ferry line, it was held that routes and rates for the transportation of soft coal from mines in West Virginia and Kentucky on or tributary to the Chesapeake & Ohio and the Kanawha & Michigan to Milwaukee and other Wisconsin points for further shipment beyond those points, must be maintained. The supplemental case involves the Grand Trunk and car ferry lines as delivering lines. Since the conditions surrounding the transportation of coal from the mines in question to Milwaukee via the Grand Trunk have not been shown to be materially different from those obtaining via the Pere Marquette, the finding is the same as in the original case, viz., that the present routes must be maintained and that proportional rates may be increased not more than 10 cents per ton. (28 I. C. C., 527.)

#### Complaint Dismissed.

*Scott-Mayer Commission Company v. Chicago, Rock Island & Pacific, et al. Opinion by the commission:*

The complainant alleges that the defendants' separately established rate of 19 cents per hundred pounds on apples in carloads from Memphis, Tenn., to Little Rock, Ark., applicable to through shipments from the Cumberland Valley region of Pennsylvania, is unreasonable and unjustly discriminatory because defendants maintain a proportional rate of 13 cents from Memphis to Little Rock on apples forwarded as through shipments to Little Rock from points in western New York. No evidence was presented to show that the 19-cent rate was unreasonable, except as compared to the 13-cent rate, nor was any complaint made against the unreasonableness of the through rate. The commission holds that under the circumstances it will not disturb the factor under consideration, except upon the showing that such factor or the through rate of which it is a part, is unreasonable or otherwise in violation of the act. (28 I. C. C., 529.)

REVENUES AND EXPENSES OF RAILWAYS.

MONTH OF OCTOBER, 1913.

Table with columns: Name of road, Average mileage operated during period, Freight, Passenger, Total, Operating revenues, Way and structures, Maintenance of equipment, Trans- portation, Traffic, Total, Net operating revenue, Outside operations, Taxes, Operating income, Increase (or decr.) last year.

FOUR MONTHS OF FISCAL YEAR, 1914.

Table with columns: Name of road, Average mileage operated during period, Freight, Passenger, Total, Operating revenues, Way and structures, Maintenance of equipment, Trans- portation, Traffic, Total, Net operating revenue, Outside operations, Taxes, Operating income, Increase (or decr.) last year.



REVENUES AND EXPENSES OF RAILWAYS.

FOUR MONTHS OF FISCAL YEAR, 1914—CONTINUED.

Name of road.	Average mileage operated during period.	Operating revenues			Maintenance		Trans- portation.	Traffic.	Total.	Net operating revenue (or deficit).	Outside operations, net.	Taxes.	Operating income (or loss).	Increase (or de- crease) last year.
		Freight.	Passenger.	inc. misc.	Total.	Way and structures.								
Lake Erie & Western.....	906	\$1,662,799	\$343,556	\$2,131,972	\$446,138	\$374,268	\$799,257	47,992	\$1,716,501	\$415,490	\$66,623	\$88,852	\$326,638	\$220,876
Lake Shore & Michigan Southern.....	1,853	12,826,776	5,097,984	20,120,371	4,112,130	3,807,795	6,133,536	380,795	14,328,080	5,792,292	66,623	615,000	5,243,915	1,857,713
Lehigh & Hudson River.....	97	556,845	20,350	612,638	139,869	97,843	222,660	6,136	483,424	129,214	.....	12,714	113,214	27,115
Lehigh & New England.....	269	601,427	2,350	623,176	92,203	84,183	154,465	35,035	354,696	268,480	.....	12,714	253,766	27,487
Lehigh Valley.....	1,438	12,087,551	1,978,686	14,581,420	1,701,039	2,498,615	4,775,193	345,035	9,595,546	4,985,874	89,302	484,000	4,414,572	758,885
Long Island.....	399	1,132,219	3,370,160	5,040,723	559,335	466,543	1,950,663	80,949	3,165,534	1,875,189	10,215	254,640	1,610,334	249,711
Louisiana & Arkansas.....	279	456,207	92,405	568,510	100,614	85,493	1,045,078	10,041	362,280	206,230	.....	16,666	189,564	362,226
Louisiana Ry. & Navigation.....	351	503,566	101,199	646,586	129,920	79,594	2,666,314	26,287	120,549	103,499	.....	29,500	173,779	8,584
Louisiana Western.....	208	470,602	248,578	757,263	87,235	173,182	2,387,387	29,607	556,167	203,096	.....	29,500	173,779	7,421
Louisville & Nashville.....	4,923	15,119,249	4,785,005	21,142,239	3,293,038	4,184,733	6,949,733	412,443	15,263,064	5,879,175	90	602,433	5,276,652	224,095
Louisville, Henderson & St. Louis.....	200	298,183	154,037	479,856	95,633	58,932	1,497,970	122,761	334,664	145,192	966	14,400	131,758	78,359
Maine Central.....	1,207	2,407,629	1,518,838	4,184,356	418,436	2,087,219	1,546,019	52,757	3,049,413	1,134,943	7,359	189,289	938,293	185,758
Michigan Central.....	1,819	7,563,524	3,698,483	12,446,236	2,087,219	2,183,216	4,962,035	211,845	9,717,345	2,728,891	1,110	464,000	2,266,991	1,221,737
Midland Valley.....	373	401,026	165,608	593,913	120,475	111,493	1,983,966	10,311	466,076	129,857	233	23,947	106,123	1,672
Minnesota & St. Louis.....	1,586	2,447,837	760,379	3,406,363	478,340	464,622	1,207,885	78,447	2,299,563	1,107,400	196	134,234	972,970	64,504
Minneapolis, St. Paul & Sault Ste. Marie.....	3,979	7,786,629	2,730,972	11,137,249	1,438,479	1,621,527	3,318,114	226,439	6,835,927	4,301,322	91,756	507,923	3,885,155	790,764
Missouri & North Arkansas.....	365	278,424	162,565	466,001	104,133	74,057	1,668,889	14,548	381,563	84,438	.....	22,000	62,438	70,038
Missouri, Kansas & Texas System.....	3,817	7,345,251	3,469,423	11,574,631	1,837,620	1,441,720	4,155,614	374,353	8,062,278	3,512,353	44,703	482,600	2,985,050	585,088
Missouri, Oklahoma & Gulf.....	332	304,206	91,994	413,473	71,824	62,660	1,799,734	23,224	363,297	50,176	1,833	24,000	28,009	10,697
Missouri, Okla. & Gulf Ry. Co. of Texas.....	35,001	2,295	37,821	3,660	.....	.....	.....	716	36,101	.....	.....	685	1,035	3,756
Missouri Pacific.....	3,920	7,545,517	1,866,171	10,210,454	1,648,575	1,898,705	3,974,283	253,164	8,059,249	2,151,205	16,409	376,070	1,788,726	244,965
Mobile & Ohio.....	1,122	3,593,850	541,578	4,377,422	521,723	368,938	1,601,420	137,136	3,274,355	1,103,067	5,606	132,323	965,138	39,686
Monongahela.....	67	524,202	11,548	541,553	71,242	31,717	1,044,532	1,529	219,532	322,321	.....	9,400	313,921	14,412
Monongahela Connecting.....	6	.....	.....	366,316	45,629	70,343	1,044,532	1,529	219,532	322,321	.....	9,400	313,921	14,412
Morgan's La. & Tex. R. R. & S. Co.....	404	949,101	397,938	1,455,434	184,640	288,329	623,567	48,035	1,193,450	261,984	7,780	73,000	181,504	21,073
Nashville, Chattanooga & St. Louis.....	1,231	2,859,981	1,140,580	4,289,011	678,010	846,019	1,599,094	167,270	3,410,996	878,035	2,804	101,300	773,871	156,947
Nevada Northern.....	165	530,856	54,683	599,974	69,470	17,493	1,414,118	1,433	301,311	298,663	.....	33,291	265,372	15,072
New Orleans & North Eastern.....	196	1,058,991	226,237	1,375,738	147,060	281,869	512,362	41,301	1,025,698	350,040	853	63,200	285,987	54,873
New Orleans Great Northern.....	283	464,221	139,044	604,457	88,656	64,920	1,555,128	11,555	454,457	271,445	384	9,334	2,617,727	66,074
New Orleans, Mobile & Chicago.....	403	566,992	133,139	745,665	99,010	76,846	234,969	14,953	455,780	289,885	429	27,269	265,187	16,823
New Orleans, Texas & Mexico.....	286	333,379	71,323	487,959	124,921	46,034	199,341	12,388	420,512	66,547	5,734	60,813	60,813	20,400
New York Central & Hudson River.....	3,751	24,038,009	13,930,513	42,340,359	6,546,259	7,868,541	14,454,005	816,902	30,729,374	11,660,985	12,755	2,388,200	9,266,030	697,220
New York, Chicago & St. Louis.....	566	3,366,038	654,445	4,131,151	563,270	685,230	1,793,311	197,415	3,622,321	908,900	10,150	147,000	751,750	359,323
New York, New Haven & Hartford.....	2,060	11,410,846	10,300,936	24,040,218	3,195,197	3,231,986	1,979,519	179,759	16,210,311	7,825,917	34,492	1,820,000	6,640,409	2,303,308
New York, Ontario & Western.....	566	2,425,091	948,385	3,596,921	575,144	546,578	1,185,380	44,815	2,417,999	1,511,922	245	76,000	1,075,677	194,195
New York, Philadelphia & Norfolk.....	112	1,095,406	207,551	1,396,930	115,824	291,204	584,435	20,925	1,068,055	328,875	.....	32,000	296,875	47,478
New York, Susquehanna & Western.....	154	692,997	206,605	1,010,714	161,934	131,219	470,701	8,724	740,292	270,422	7,301	63,238	214,485	12,377
Norfolk & Western.....	2,035	13,554,370	1,871,798	15,979,393	2,035,226	3,245,226	4,885,366	46,808	10,715,995	5,263,398	6,163	500,000	4,757,235	284,963
Norfolk Southern.....	569	689,061	307,129	1,099,125	142,236	155,818	347,004	18,493	58,669	722,440	628	36,909	39,148	2,377
Norfolk Central.....	472	3,466,822	984,967	4,753,289	642,840	1,043,375	2,211,529	79,771	4,089,621	663,668	4,092	173,561	494,199	285,983
Northern Pacific.....	6,313	18,529,826	6,507,798	26,665,744	4,211,690	3,086,412	7,940,093	455,429	16,032,331	10,633,413	190,039	1,444,080	9,399,372	516,031
Northern Pacific.....	401	614,634	840,729	1,548,773	207,892	156,481	479,091	16,692	908,408	640,365	.....	60,400	579,965	3,471
Oahu Ry. & Land Co.....	101	326,893	104,998	458,622	35,259	32,529	179,733	2,625	179,733	278,889	10,482	27,870	240,537	4,721
Oregon Short Line.....	2,023	6,053,862	1,997,119	8,539,654	1,062,776	958,716	1,945,578	158,894	4,337,176	4,202,478	51	514,320	3,688,209	306,337
Oregon-Washington K. R. & Nav. Co.....	1,914	4,386,432	1,987,344	6,811,345	1,040,914	735,554	218,530	417,686	235,065	4,377,749	25,950	451,873	1,955,773	48,526
Pecos & Northern Texas.....	482	621,255	174,351	839,766	98,275	158,242	248,408	11,153	542,534	297,232	.....	30,145	267,087	15,973
Pennsylvania Co.....	1,751	18,654,795	3,878,089	24,763,137	3,326,035	4,416,107	6,615,571	360,722	17,162,220	7,600,917	35,504	1,016,375	6,594,038	1,125,372
Pennsylvania Railroad.....	4,032	47,084,869	14,286,165	65,765,735	8,179,971	13,284,550	985,260	23,043,957	46,970,730	18,795,005	615,575	2,520,918	15,638,512	793,629
Peoria & Eastern.....	352	816,173	266,226	1,182,499	167,377	256,467	457,397	21,852	976,487	256,012	.....	43,600	212,412	68,876
Pere Marquette.....	2,325	3,732,034	1,674,458	5,936,696	1,050,017	1,231,920	2,416,695	134,664	4,999,901	936,795	10,649	199,167	726,979	743,089
Philadelphia & Reading.....	1,020	13,130,978	2,665,572	16,579,340	1,867,709	3,004,913	1,905,889	158,589	10,684,434	5,895,106	95,229	410,983	5,579,352	1,366,676
Philadelphia, Baltimore & Washington.....	713	3,691,889	2,971,450	7,368,433	1,264,099	1,376,578	3,063,998	194,275	6,034,555	3,333,878	.....	222,036	1,111,842	486,626
Philadelphia & Lake Erie.....	253	6,017,288	708,426	6,972,768	739,880	1,290,874	6,130,118	63,285	3,838,571	3,134,197	872	228,000	2,907,069	676,430
Pittsburgh, Cincinnati, Chic. & St. Louis.....	1,472	11,002,330	3,350,998	16,031,371	2,462,997	3,164,221	2,951,465	293,366	12,145,976	3,885,395	2,796	604,279	3,282,320	909,318
Pittsburgh, Shawmut & Northern.....	282	700,799	46,044	756,921	197,329	200,627	261,239	7,219	686,854	20,067	.....	7,314	62,753	117,636
Port Reading.....	21	408,974	415,568	819,391	65,399	447	122,386	123	192,606	222,962	645	40,000	182,317	188,316
Richmond, Fredericksburg & Potomac.....	88	462,092	317,202	893,994	104,526	112,545	340,530	12,992	508,224	295,770	2,410	68,400	260,950	39,269
Ridgeland.....	468	692,651	536,980	1,420,439	149,946	278,588	499,308	41,440	992,811	427,626	676	38,404	359,898	5,252
St. Joseph & Grand Island.....	319	395,027	138,103	579,352	122,185	84,433	227,437	20,138	475,530	359,822	.....	25,007	74,789	163,570
St. Louis & San														

REVENUES AND EXPENSES OF RAILWAYS.

FOUR MONTHS OF FISCAL YEAR, 1914—CONTINUED.

Name of road.	Average mileage operated during period.	Operating revenues			Operating expenses			Net operating revenue (or deficit).	Outside operations, net.	Taxes.	Operating income (or loss).	Increase (or decr.) comp. with last year.
		Freight.	Passenger.	Total.	Way and structures.	Maintenance of equipment.	Trans- portation.					
Southern	7,037	\$15,078,349	\$6,895,450	\$23,670,394	\$3,235,999	\$3,874,053	\$7,298,052	\$16,545,591	\$18,964	\$840,743	\$6,302,924	-\$417,364
Kansas of Texas	179	370,798	70,139	462,705	66,280	83,528	6,340	308,091	154,114	16,928	137,186	-73,561
Southern Pacific Co.	6,380	20,031,274	11,209,634	33,318,114	3,561,269	4,561,269	6,002,235	18,645,763	6,238,677	1,605,267	14,191,251	-1,836,768
Spokane International	163	278,184	98,494	393,254	20,609	24,349	110,698	218,415	176,839	12,082	164,757	-19,036
Spokane, Portland & Seattle	556	1,088,009	672,949	1,928,551	441,127	551,349	34,802	915,321	1,013,530	213,600	806,074	-33,223
Tennessee Central	294	400,665	170,615	602,656	117,423	55,214	200,631	425,259	177,397	16,282	160,415	25,001
Terminal Railroad Ass'n of St. Louis	34	958	958	1,001,652	86,913	180,126	3,643	344,431	344,431	106,600	257,381	101,969
Texas & New Orleans	458	904,739	444,157	1,438,247	235,571	341,427	31,771	1,236,629	201,618	86,990	1,244,228	-54,220
Texas & Pacific	1,885	4,101,374	1,670,615	6,247,644	867,094	965,397	150,021	4,440,969	1,660,284	1,922,576	1,462,168	525,016
Toledo & Ohio Central	443	1,907,149	259,769	2,305,171	385,789	429,490	88,973	1,714,987	563,184	78,847	482,115	-77,689
Toledo, Peoria & Western	248	281,786	189,148	502,787	104,056	118,148	10,117	477,779	55,008	20,000	35,008	-7,049
Toledo, St. Louis & Western	451	1,374,527	153,466	1,623,022	175,285	224,210	62,938	1,050,802	573,120	62,000	510,520	172,206
Trinity & Brazos Valley	463	911,527	311,283	1,222,810	207,673	136,849	4,321	836,472	240,106	21,990	135,884	-192,491
Utah & Delaware	120	249,017	204,811	477,195	66,293	53,725	188,177	327,394	14,000	71,351	8,849,836	-54,1284
Utah Pacific	3,612	13,974,183	4,227,588	19,885,510	2,122,668	2,467,727	438,933	10,309,417	9,574,093	71,351	8,849,836	-54,1284
Union R. R. of Baltimore	9	487,251	98,515	592,896	45,491	.....	5,143	509,676	.....	24,047	485,629	21,403
Union R. R. of Pennsylvania	31	.....	1,941,656	237,759	237,759	413,135	409	690,898	12,597	42,000	555,312	-255,727
Vandalia	910	2,826,772	936,641	4,192,919	569,269	779,732	110,197	1,552,260	586,858	121,264	980,431	114,373
Vicksburg, Shreveport & Pacific	171	348,820	202,298	596,348	105,504	118,634	13,919	207,555	138,215	31,200	106,702	-2,038
Virginia & Southwestern	240	589,311	71,629	679,330	90,361	150,504	8,575	186,322	228,016	23,909	204,107	42,516
Virginian	503	2,055,205	149,384	2,261,751	289,654	352,258	23,209	1,192,317	1,069,434	84,845	1,014,367	31,680
Washington	2,135	7,437,212	2,880,848	11,247,679	1,363,365	1,824,230	370,975	8,152,786	3,094,893	297,790	2,780,771	-233,773
Washington Southern	36	141,374	135,783	402,160	59,244	57,862	3,121	163,638	12,654	14,027	88,868	-29,252
Western Maryland	661	2,365,670	488,989	2,981,474	478,395	441,374	102,550	2,374,263	706,211	79,500	527,711	-48,848
Western Pacific	937	1,907,573	583,331	2,552,404	485,432	443,106	12,777	828,808	115,288	122,746	642,375	-49,928
Western Ky. of Alabama	133	269,638	187,794	496,341	86,124	99,085	24,097	136,952	23,171	19,353	107,500	10,485
West Jersey & Seaboard	356	680,131	212,908	2,980,609	412,725	441,882	78,248	2,025,860	954,749	110,071	829,394	-176,272
Wheeling & Lake Erie	459	2,822,489	258,812	3,236,351	583,814	576,681	34,379	2,231,127	1,005,224	131,151	873,609	-186,875
Yazoo & Mississippi Valley	1,372	2,739,179	905,611	3,912,983	669,124	673,022	62,555	2,963,382	949,601	172,000	774,360	312,801

Nashville Coal Rates Reduced.

The Traffic Bureau of Nashville, Tenn., v. Louisville & Nashville, et al. Opinion by Commissioner McCord:

Nashville, Tenn., through its traffic bureau as complainant, attacks the rate of one dollar per ton on coal to Nashville from western Kentucky mines on the Louisville & Nashville and the Illinois Central, and from mines in eastern Tennessee and Alabama on the Nashville, Chattanooga & St. Louis. This coal is being hauled to Nashville by the Louisville & Nashville at a rate of \$1 per ton, which nets a per ton mile revenue of 9.2 mills for an average haul of 108.5 miles. At the same time coal is being carried from the same coal fields to Memphis, Tenn., at \$1.10 per ton; the distance is 276 miles, which nets a per ton mile revenue of slightly less than four mills. The commission finds that there is no real dissimilarity in operating conditions as between the two points, and dismisses the contention that the difference in rates is caused by water competition at Memphis, by showing that the facts prove that the low rate is a result of rail competition. A like comparison may be made with Louisville, which has a 60-cent rate. The commission, therefore, prescribes a rate of 80 cents. A like rate from Nashville, Chattanooga and St. Louis mines in Tennessee and Alabama is also found to be unreasonable and a rate of 90 cents is prescribed, but the complainant as to the unreasonableness of the \$1 rate to Nashville on coal from Illinois Central western Kentucky mines is not sustained. The question of switching at Nashville also arises. The Louisville & Nashville and the Nashville, Chattanooga & St. Louis interswitch all traffic, including coal at that point. They refuse to switch coal to and from the Tennessee Central, which road retaliates by refusing to switch coal to or from the rails of either of the other two. The commission finds that the practice of all three roads is unreasonable and further, that that of the Louisville & Nashville and the Nashville, Chattanooga & St. Louis is unjustly discriminatory. The discrimination is required to be removed and reasonable practice prescribed. "Terminals are either open or they are not" and a carrier may not exercise an arbitrary discretion, based upon a strained construction of the provision of section 3, in saying for what road and traffic it will open its terminals and for what other roads and traffic it will decline to do so. (28 I. C. C., 533.)

Grain Rates in Central Freight Association Territory.

Opinion by Commission Prouty:

The commission finds that the proposed increase in re-shipping rates on malt from Milwaukee and Chicago to points in Central Freight Association territory and to western termini of the trunk lines has been justified, for at present the basis of rate is not equitable. For example, the joint through rate on malt from Minneapolis to Pittsburgh is 18 cents. At the same time there is a rate on malt and barley from Minneapolis to Chicago of 7½ cents and a re-shipping rate from Chicago to Pittsburgh of 9.2 cents, producing a combination from Minneapolis to Pittsburgh of 16.7 cents. Certain proposed increases in rates on by-products of grain from Mississippi river crossings have not been justified, for the increases have the effect of putting higher rates on the by-products than on the products with which they compete. Carriers also have not justified the proposed increases in proportional rates from upper Mississippi river crossings, for the rates from the upper and lower crossings should agree. The commission also holds that a general increase in grain rates from Illinois points to markets of consumption has been justified. It is felt that the rates on grain should be placed on a percentage basis just as the rates on other commodities. A comparison has been made between the proposed rates and dates adjudged from an application of percentage groups to the present 20½-cent grain rate, and it is found that the proposed rates would be exceeded by the percentage group rates. The commission does not pass on the lawfulness of certain individual rates. (28 I. C. C. 549.)

STATE COMMISSIONS.

Frank H. Funk has been appointed a member of the Illinois State Railroad and Warehouse Commission, succeeding J. A. Willoughby.

The sub-committee of the National Association of Railroad Commissioners, which is charged with matters in connection with

the valuation work of the Interstate Commerce Commission, has chosen as its chairman Milo R. Maltbie of the New York State Public Service Commission, First district.

The Public Service Commission of Pennsylvania has made public an opinion by its counsel, William N. Trinkle, to the effect that it is not illegal for the Pennsylvania and other roads of the state to furnish free transportation for cans of fish fry for the State Department of Fisheries. The Pennsylvania had decided that this service would be forbidden by the new law. Mr. Trinkle holds that the transportation furnished is in the public interest.

The California State Railroad Commission has revised and ordered reductions in the freight rates charged by the Sierra Railway Company operating in Calaveras, Tuolumne and San Joaquin counties, declaring that they are discriminatory. The commission finds that officers of the railway company are interested in certain lumber companies in that territory and that freight rates allowed on lumber shipped by those companies have been so low as to constitute direct discrimination against other shippers. The commission also challenges the company's argument that it should receive rates sufficiently high to enable the payment of interest on bonds and dividends on the present outstanding stock.

#### COURT NEWS.

In the Federal court in New York City, last week, Simon Lewie was fined \$250 for false classification of freight in shipping decorated glass shades under the general classification of glass, thereby saving 16 cents per 100 lb. At the same time L. J. Botting was fined \$500 for describing a mixed shipment as hardware and for billing cigarettes and tobacco as tobacco alone.

The Wichita Falls & Northwestern has been indicted by a federal grand jury at Lawton, Okla., for alleged rebating through rental for unloading facilities. In order to secure the hauling of material for some public works at Altus, Okla., the road agreed to furnish a place on its right of way for the city to unload; and having no such place one was rented by the company for that purpose. The rental money is held to be equivalent to a rebate.

On December 20, Judge McPherson, of the Federal Court at Kansas City, Mo., dismissed without prejudice the injunction suits in the Missouri 2-cent fare and maximum freight rate cases under the mandate of the United States Supreme Court, without retaining jurisdiction over the claims for refunds of the amounts collected in excess of the rates finally sustained. The attorney-general of the state immediately filed a suit against the Missouri Pacific for refunds amounting to about \$2,000,000, after which the Court, at the petition of the railways, entered a new order suspending the decrees until January 10. The attorney-general announced that he would proceed with the filing of suits for refunds against the other roads.

A hearing in the suit of the protective committee of the minority stockholders of the St. Joseph & Grand Island against the Union Pacific to enforce the payment of dividends on the St. Joseph & Grand Island stock, was begun in the federal court at Omaha on December 17. It is charged that the Union Pacific, after obtaining control of the stock, has expended excessive amounts on improving a part of the line for the benefit of the Union Pacific, instead of paying dividends to which the stockholders are entitled. Nelson P. Loomis, in presenting the argument of the Union Pacific, said that the improvements were necessary for the sake of the St. Joseph & Grand Island itself, and are of greater benefit to it than the Union Pacific; that the additional business which the Union Pacific will turn over to the road will amount to \$300,000 per year.

**A SWISS RAILROAD STATION.**—The Swiss federal railway system has nearly completed its \$600,000 railroad station at St. Gall. The structure is one of the finest stations in Switzerland. Its erection necessitated the building of a new postoffice immediately opposite, on which \$700,000 has been spent. The old track through the streets of St. Gall has been abandoned and trains now run through the recently completed tunnel between St. Gall and St. Fiden.

## Railway Officers.

### Executive, Financial and Legal Officers.

John R. Kenly, third vice-president of the Atlantic Coast Line, with headquarters at Wilmington, N. C., has been elected president, succeeding T. M. Emerson, deceased.

B. C. Prince, assistant general freight agent of the Seaboard Air Line, at Jacksonville, Fla., has been appointed assistant to vice-president (in charge of traffic) with office at Norfolk, Va., effective January 1.

John H. Peyton, assistant to president of the Louisville & Nashville and chief engineer of construction of the Lexington & Eastern, with headquarters at Lexington, Ky., has been elected president of the Nashville, Chattanooga & St. Louis, effective April 1, 1914, succeeding John W. Thomas, Jr., deceased. In the meantime Maj. E. C. Lewis, chairman of the board, will serve as executive.

### Operating Officers.

J. M. Davis, general superintendent of the central district of the Southern Pacific, with headquarters at San Francisco, Cal., has resigned, effective January 1, to accept service with another company.

J. S. Dean, trainmaster of the Northern Pacific at Tacoma, Wash., has been appointed assistant superintendent of the Tacoma division, with headquarters at Tacoma, succeeding T. E. Coyle, promoted; effective January 1.

Charles W. Jones, general manager of the third district of the Chicago, Rock Island & Pacific, with headquarters at El Reno, Okla., has been appointed general manager of the first district, with headquarters at Des Moines, Iowa, succeeding W. M. Whinton, resigned; effective January 1. A photograph and sketch of Mr. Jones were published in the *Railway Age Gazette* of February 9, 1912, page 258.

Albert James Stone, general manager of the Eastern grand division of the Erie, with office at New York, will on January 1, succeed to the duties of vice-president J. C. Stuart, with



A. J. Stone.

authority throughout the Erie lines, and will be the ranking general manager, without a change of title, as has already been announced in these columns. Mr. Stone was born on February 20, 1873, at Holly, Mich., and was educated at Hornell High School at Hornell, N. Y., and at Elmira Business College, Elmira, N. Y. He began railway work on the New York, Lake Erie & Western as a messenger in 1888, and held various subordinate positions in the operating department of that road and its successor, the Erie, until 1902. From July, 1902, to November, 1903, he was assistant to the general manager of the same road, and then, to 1905, was general superintendent of the Delaware & Hudson. In November, 1905, he returned to the Erie and became assistant general manager of the Erie and its allied and controlled lines. On August 6, 1907, he was promoted to general superintendent. He has been general manager since the beginning of the present year.

T. H. Beacom, assistant general manager of the first district of the Chicago, Rock Island & Pacific, at Des Moines, Ia., has been appointed general manager of the third district, with headquarters at El Reno, Okla., succeeding C. W. Jones. F. J.

Easley, assistant general manager of the third district, is appointed assistant general manager of the first district, with office at Des Moines, succeeding Mr. Beacom.

John J. Mantell, whose appointment as superintendent of the Wyoming division of the Erie, with headquarters at Dunmore, Pa., has been announced in these columns, was born at Elmira, N. Y., and was educated in the public schools of his native town and at Elmira Academy. He began railway work on June 24, 1899, as a clerk in the roadmaster's office of the Erie at Elmira, and has been in the continuous service of that road ever since. From 1899, to December, 1906, he was consecutively yard clerk, chief yard clerk, clerk stenographer, and assistant chief clerk in the division superintendent's office at Elmira, N. Y., also at Hornell, and in the general superintendent's office at Jersey City, N. J. In December, 1906, he was appointed yardmaster of the Jersey City Terminal, and in October, 1908, was made general yardmaster at Susquehanna, Pa. From June, 1909, for one year, he was traveling yardmaster on the general superintendent's staff, and then, to May, 1911, was trainmaster on the Delaware & Jefferson division. On May 1, 1911, he was appointed a special agent on the general superintendent's staff, becoming terminal trainmaster at Jersey City the following December, which position he held at the time of his recent appointment as superintendent of the Wyoming division of the same road, as above noted.

John B. Dickson, whose appointment as assistant general manager of the Ohio grand division of the Erie, with headquarters at Cleveland, Ohio, effective January 1, has already been announced in these columns, was born at Steubenville, Ohio, and began railway work in 1881, in the maintenance of way department of the Cleveland & Pittsburgh division of the Pennsylvania Lines West of Pittsburgh. From April, 1887, to February, 1893, he was supervisor of the same division, and then, to January 1, 1902, was roadmaster on the Galena division of the Chicago & North Western. He was then, for one year, assistant engineer, maintenance of way, on the Baltimore & Ohio, and was promoted in January, 1903, to engineer maintenance of way, becoming chief engineer maintenance of way of the same road in June, 1905. He was subsequently assistant to general manager of the Erie, and then superintendent of the Rochester division of the same road. On July 1, 1909, he was appointed general agent of the operating department of the Erie at Chicago, and in January, 1913, was made superintendent of the New York division, with headquarters at Jersey City, N. J., which position he held at the time of his recent appointment as assistant general manager of the Ohio grand division of the same road, as above noted.



J. B. Dickson.

Joseph Hildeburn Gumbes, whose appointment as superintendent of the Renovo division of the Pennsylvania Railroad, with headquarters at Renovo, Pa., has been announced in these columns, was born on November 27, 1866, at Oaks Station, Montgomery county, Pa., and was graduated from the engineering department of the University of Pennsylvania in the class of 1888. During his summer vacations he was employed in the engineering department of the Pennsylvania Railroad, and in the spring of 1888, he became a rodman on the Middle division. In December, 1890, he was transferred to the maintenance of way department at Altoona, becoming assistant supervisor in August, 1891, at Freeport, Pa. He was subsequently transferred in a similar capacity to Mifflin, on the Middle division. In July, 1897, he was promoted to supervisor at Millersburg, and in October, 1899, was transferred in the same capacity to the

Monongahela division at Dravosburg, returning to Mifflin as supervisor in January, 1900. From December, 1901, to June, 1903, he was supervisor at New Florence, Pa., on the Pittsburgh division, and then was promoted to division engineer of the Monongahela division. On April 1, 1905, he was transferred as division engineer to the West Jersey & Seashore, and two years later became division engineer of the Pittsburgh division. He was promoted to assistant superintendent of the Pittsburgh division on March 3, 1911, with office at Youngwood, Pa., which position he held at the time of his recent appointment as superintendent of the Renovo division of the same road, as above noted.

#### Traffic Officers.

Ingram T. Sparks has been appointed traveling freight and passenger agent of the Southern Pacific and the Arizona Eastern at Phoenix, Ariz.

A. J. Patton has been appointed traveling freight agent of the Sunset-Central Lines at Waco, Tex., succeeding Robert Burns, who has been transferred to Houston, Tex.

The office and department of J. D. Cornell, general freight and passenger agent of the Rock Island Southern, will be removed on January 1, from Monmouth, Ill., to Davenport, Iowa.

Joseph A. S. Wallace, traveling freight agent of the Chicago, Milwaukee & St. Paul, at Pittsburgh, Pa., has been appointed traveling freight agent of the Western Maryland, with headquarters at Pittsburgh.

J. B. Gibson has been appointed traveling freight agent of the Kansas City Southern at Houston, Tex., succeeding H. G. Moran, who has been appointed soliciting freight agent of the Chicago, Rock Island & Pacific at Houston, succeeding P. L. McCue, resigned.

J. L. Greenwood has been appointed traveling freight agent of the International & Great Northern and the Texas & Pacific at Los Angeles, Cal., succeeding C. K. Blech, resigned, and A. E. Sinclair has been appointed traveling freight agent at San Francisco, Cal., succeeding R. C. Melvin, resigned.

Eugene Fox, general freight and passenger agent of the El Paso & Southwestern at El Paso, Tex., has been appointed assistant general traffic manager, with headquarters at Chicago, and William C. Barnes, assistant general freight agent at El Paso, has been appointed general freight agent, with headquarters at El Paso.

#### Engineering and Rolling Stock Officers.

William Garstang, general master car builder of the Cleveland, Cincinnati, Chicago & St. Louis and the Peoria & Eastern, will retire from railroad service at the end of the year, after an active career of 50 years in the mechanical department.



W. Garstang.

Until February of this year, Mr. Garstang was superintendent of motive power of the Cleveland, Cincinnati, Chicago & St. Louis, the Peoria & Eastern, and the Cincinnati Northern, and had held the title of superintendent of motive power for 25 years, 20 years with the Big Four and for 5 years, from 1888 to 1893, with the Chesapeake & Ohio. In February of this year he was relieved of a portion of his duties, and has since served mainly in an advisory capacity with the title of general master car builder. His former duties will continue to be performed by S. K. Dickerson, superintendent motive power, and I. S. Downing, master car builder. Mr. Garstang was born February 28, 1851, in England, and was educated in

the public schools. In 1862 he carried water for the contractors on the laying of track from Fort Erie to Niagara on the Canadian shore of the Niagara river, and in December, 1863, entered railway service as a machinist apprentice on the Cleveland & Erie, now part of the Lake Shore & Michigan Southern, at Cleveland, Ohio, where he remained six years. During this period he went to night school and studied mathematics and mechanical drawing. He was then for 11 years machinist and general foreman of the Atlantic & Great Western and the New York, Pennsylvania & Ohio; for three years general foreman of the Cleveland & Pittsburgh division of the Pennsylvania; for five years master mechanic of the Cleveland, Columbus, Cincinnati & Indianapolis, now the Cleveland, Cincinnati, Chicago & St. Louis, and in 1888 he was appointed superintendent of motive power of the Chesapeake & Ohio. On April 1, 1893, he was appointed superintendent of motive power of the Cleveland, Cincinnati, Chicago & St. Louis, which position he held until February 10, 1913. He has thus been connected for approximately 30 years with Vanderbilt roads, and during that time he has been closely identified with the wonderful progress that has been made in railroading. During his first service on the Cleveland & Erie the link and pin coupler was used on passenger cars as well as freight cars; passenger cars were heated by wood stoves and lighted by sperm candles, and portable platforms were used between cars during stops to keep people from falling through; the locomotives burned wood, weighed only about 70,000 lbs., and were equipped with valve gears having the hook motion and the independent cut off, and wooden brake beams, brake heads and brake shoes were used, over the route that is now traversed by the Twentieth Century Limited. Mr. Garstang has been connected with the Master Car Builders' Association and Master Mechanics' Association for about 35 years, and was president of the Master Mechanics' Association in 1894 and 1895. He has served on the committees that adopted the M. C. B. standard car axle, journal box, journal brass, journal wedge, and the standard wheel, and for the past 12 years has been chairman of the committee on standard wheels. When this committee first took up the wheel question there were 45 different designs in use, which have now been reduced to designs for 60,000, 80,000 and 100,000 lb. capacity cars. One of his most important recent achievements was the erection of the Big Four shops at Beech Grove, Ind., which he designed and contracted for, and the work was carried on under his supervision, in addition to his other duties.

William Cary Hattan, whose appointment as division engineer of the Carolina, Clinchfield & Ohio, with headquarters at Dante, Va., has been announced in these columns, was born on December 15, 1875, in Rockbridge county, Va. He took a course in civil engineering at the Washington and Lee University and received the degree of B.S. In July, 1899, he began railway work with the West Virginia Short Line, now a part of the Baltimore & Ohio, and held various positions, including that of rodman, until 1902. He was then resident engineer of the Ozark & Cherokee Central, now a part of the St. Louis & San Francisco, and later assistant engineer of Vandewater & Hood, civil engineers of Baltimore, Md. In 1904 he became resident engineer on the Cumberland extension of the Western Maryland, and from 1906 to 1909 was resident engineer on the Carolina, Clinchfield & Ohio in charge of heavy tunnel and viaduct work. During the next two years he was division engineer for the Carter Construction Company in charge of sub-contractors at work on extension to Connellsville. In 1912 he was made resident



W. C. Hattan.

engineer on the Elkhorn extension of the Carolina, Clinchfield & Ohio, which position he held at the time of his recent appointment as division engineer of the same road, as above noted.

W. F. Drysdale, mechanical engineer of the Northern Railway of Costa Rica at Limon, Costa Rica, has resigned to engage in other business.

R. L. Cooper has been appointed chief engineer of the Ft. Dodge, Des Moines & Southern, with headquarters at Boone, Iowa. He was previously engineer of the Conn Construction Company.

W. K. Walker, general roadmaster of the Missouri Pacific at Wichita, Kan., has been appointed engineer in charge of the South Omaha improvements of the road, including a new yard and a large viaduct.

#### OBITUARY.

F. S. Savage, for the past 22 years connected with the passenger department of the Atchison, Topeka & Santa Fe, a part of the time as advertising manager, died in Topeka, Kan., on December 20.

David S. Sutherland, general agent of the Michigan Central at Detroit, Mich., died at his home in Detroit on December 17. He was born in 1849 at Detroit, and had been in the service of the Michigan Central since 1864, when he started as messenger. He was later yardmaster, trainmaster and from 1880 to 1912 superintendent. On August 15 he was appointed general agent.

Christer P. Sandberg, Member of the Institute of Civil Engineers, the well known designer of the Sandberg sections of rails, died at his home in London, Eng., December 4, at the age of 81. Mr. Sandberg was born in Sweden, but had lived in England for the last 50 years. In 1868 he was awarded the Telford gold medal and a premium for his paper on the manufacture and wear of rails, an essay which is still looked upon as a standard discussion of the subject. For 40 years he had been consulting and inspecting engineer for the Swedish, Chinese and Siamese government railroads and for other railroads.

William Borner, formerly assistant to freight traffic manager of the Pennsylvania Lines at Chicago, died in that city on December 21. He was born on March 27, 1842, at Bedford, Pa., and was educated at Duff's Commercial College, Pittsburgh. He began railway work on January 1, 1857, as a messenger and was then clerk and later chief clerk of the Star Union Line until 1871, when he became cashier of the same company. From 1877 to 1881 he was agent of the Pennsylvania Company, and then to 1910 was general western and division freight agent of the same company. From 1910 to April 1, 1912, he was assistant to freight traffic manager of the Pennsylvania Lines, and then entered the banking department of the Harris Trust & Savings Bank, Chicago.

**A RAILWAY TAX IN MANCHURIA.**—On October 1 the administration of the Chinese Eastern introduced a so-called pood tax which is to be collected on each pood (36.1128 lbs.) of freight handled by the railway at Harbin in Manchuria. The tax is to remain in force for a period of 10 years, and it is estimated that during that time the revenue will amount to about \$625,000. This money will be chiefly used for improving the streets in Harbin, although some of it will also be used for other municipal improvements.

**CATTLE AND BEEF RATES IN BRAZIL.**—Argentina surpasses Brazil in both the number and the careful breeding of cattle. In the latter country the cattle business in many districts has been kept from becoming profitable by the lack of reasonable railway rates. Shipment is, therefore, conducted on a rather limited scale and driving from one point to another must often be resorted to. It is only a question of time before this method of bringing the product to market will be superseded by modern transportation facilities. Refrigerator cars are now being installed on many lines.

## Equipment and Supplies.

### LOCOMOTIVE BUILDING.

THE BALTIMORE & OHIO is reported to be inquiring for 10 tenders. This item has not been confirmed.

THE MAINE CENTRAL has ordered 4 consolidation, 3 mikado and 3 Pacific type locomotives from the American Locomotive Company.

### CAR BUILDING.

THE MONTREAL & SOUTHERN COUNTIES RAILWAY has ordered 10 high speed electric cars from the National Steel Car Company.

THE PACIFIC GREAT EASTERN, 404 Welton building, Vancouver, B. C., has ordered 44 steel frame box cars and 67 steel under-frame flat cars from the National Steel Car Company.

THE MAINE CENTRAL, mentioned in the *Railway Age Gazette* of October 31 as being in the market for 10 caboose cars, has ordered that equipment of the American Car & Foundry Company.

THE GRAND TRUNK, mentioned in the *Railway Age Gazette* of December 12 as being in the market for cars, has ordered 500 steel frame stock cars and 10 steel frame baggage cars from the National Steel Car Company.

### IRON AND STEEL.

THE NORFOLK & WESTERN has ordered 6,800 tons of steel rails from the Pennsylvania Steel Company, 11,600 tons from the Carnegie Steel Company, 6,800 tons from the Cambria Steel Company, and 3,800 tons from the Bethlehem Steel Corporation, a total of 29,000 tons.

### SIGNALING.

The Federal Signal Company is installing an all-electric interlocking machine of 80 levers for the New York Central & Hudson River at Rome, N. Y.

FROM LONDON TO SHANGHAI IN FOURTEEN DAYS.—With the institution of a proper ferry between Nanking and Pukow, the Shanghai, Nanking and the Pukow-Tientsin have arranged a through express train service which brings Shanghai within 14 days of London.

A GERMAN LOCOMOTIVE WORKS' MONTHLY MAGAZINE.—The Hanover Locomotive Works of Linden, Hanover, Germany, began with November, 1913, the publishing of a monthly magazine. The first copy contains a history of the works. It tells how George Egestorff, the son of a lime-kiln owner, founded the foundry and engineering works at Linden in 1835. It then goes on to tell that Dr. Strousberg, a railway contractor, obtained the works in 1868. Dr. Strousberg had obtained in 1861 a concession for the construction of a railway from Insterburg to Tilsit; he was also intrusted with the construction of the Southern Railway of East Prussia. He later built on his own account several lines and thereby became the head of an important railway system. He then tried to follow out a plan of making in his own establishments nearly all the material necessary for the working of his railways, and among other plants bought that at Linden. Heavy losses just before the crisis of 1873, however, compelled him to dispose of the works in 1870 to the Hanomag. There then follows a brief discussion of the development of the works. Note is made of the fact that the first locomotive was built in them in 1846. A picture of that first locomotive is given, as well as pictures of the founder and the works as they are at the present time. The English edition contains eight pages. It is printed in an extremely pretty type and very well illustrated. If the copies to follow are as attractive and instructive there can be no doubt that the magazine will meet with success.

## Supply Trade News.

The Pittsburgh Steel Products Company, Pittsburgh, Pa., has opened an office at 1933 Railway Exchange building, St. Louis, Mo., in charge of A. F. McCoolle, manager of sales, and C. F. Palmer, supervisor.

The Solvay Process Company, Semet Solvay Company, Syracuse, N. Y., has moved its New York office from 100 William street to the 42nd Street Building at the corner of Madison avenue and 42nd street.

It is expected that the new plant of the American Steel and Wire Company at Fairfield, Ala., on the outskirts of Birmingham will be put in operation shortly after the first of January. The new wire and nail making machinery is being tried out now.

The American Mason Safety Tread Company, Lowell, Mass., was awarded a gold medal at the International Exposition of Safety and Sanitation, held under the auspices of the American Museum of Safety at the Grand Central Palace, New York, December 11 to 20. Certain other awards were mentioned in our news columns last week, page 1197.

The officers and engineers of the Grip Nut Company, Chicago, some 22 in number, held a meeting at the Auditorium hotel, Chicago, on December 15 and 16, and decided to build further extensions to the company's factory and install additional labor saving machinery, particularly of a character to further improve the product. The officers of the company reported excellent business.

The officers and employees of the Automatic Electric Company, Chicago, had a banquet at the Midday Club, on December 22, to celebrate the twenty-second anniversary of the manufacture of automatic telephone apparatus. The attendance was three hundred and fifty. Fifty watch fobs were presented to employees by President Harris, for efficiency and helpful suggestions made during the year.

Franklin L. Whitcomb, who has been elected president of the Griffin Wheel Company, with headquarters at Chicago, Ill., succeeding Thomas A. Griffin, was born at Worcester, Mass., on March 5, 1862. His first business experience was with a commercial wool house in Boston from 1882 to 1884. He then went to Cleveland, where he was in the boot and shoe business for two years. For two years, from 1886 to 1888, he was with the Atchison, Topeka & Santa Fe, in the purchasing department at Topeka and at Chicago, and since 1888 he has been with the Griffin Wheel Company. He was general sales agent of that company until 1909, and in that year he was elected to the vice-presidency, from which position he has just been promoted to that of president.



F. L. Whitcomb.

A six-cylinder, 150-horsepower gasolene motor car, built by the Hall-Scott Motor Car Company, West Berkeley, Cal., was recently run under its own power from Oakland, Cal., to Mason, Nev., a distance of 337 miles over the Southern Pacific, including 69 miles of two per cent. grade. A careful record of one of these cars on the Holton Lines in California for seven months shows that it averaged 2,214 miles per month, handling passenger coach trailers and freight, and the cost of operation was 13.4 cents per mile, which covers all upkeep expenses, salaries of motorman and conductor, fuel, oil, etc. The upkeep expenses, all repairs, renewals, etc., averaged \$26.52 per month. The

gasolene consumption averaged one gallon to every four miles of operation.

Frank M. Gilmore, president of the E. D. E. Company, Chicago, and formerly for six years general railroad salesman of the H. W. Johns-Manville Company, died at his home in Chicago on December 18. Mr. Gilmore was born in Boston 49 years ago, and had lived in Chicago since 1891, and during most of that time has been engaged in the railway supply business. He was for several years mechanical expert of the Metropolitan West Side Elevated Railway, and for three years was connected with A. Sorge, Jr. He was for six years with H. W. Johns-Manville Co., and became president of the E. D. E. Company two years ago. Funeral services were held on Sunday, December 21. Mr. Gilmore was a well-known man in the railway supply business and had a host of friends, both among supply men and railway men.

Sidney Wright Hopkins, retired railway merchant and financier died on December 11 at the age of 77 years. Mr. Hopkins was born at Newburgh, N. Y., and began his business career in 1850. Ten years later he joined his father in the establishment of the firm of E. A. & S. W. Hopkins, importers and dealers in railway appliances and supplies and negotiators of railway and other securities in America and Europe. In 1866 he became the senior member of the firm of S. W. Hopkins & Co., which established branches in London. This firm financed the construction of the Port Huron & Lake Michigan and the Peninsular railways of Michigan, Indiana and Illinois, which were later consolidated as the Chicago & Lake Huron, which in turn was reorganized as the Chicago & Grand Trunk. In 1874 Mr. Hopkins reorganized the People's Gas, Light & Coke Company of Chicago. Among other offices, he at one time held that of president of the American Construction Company. In 1907 he became president of the Trojan Car Coupler Company of New York.

Thomas A. Griffin, whose election as chairman of the board of directors of the Griffin Wheel Company, Chicago, was announced in these columns last week, was born August 28, 1852, at Rochester, N. Y. His first business experience was as an apprentice at Rochester, and he has been in the car wheel manufacturing business continuously since 1868. He went to Detroit in 1875 and operated for the Michigan Car Company its plant known as the Detroit Car Wheel Company, manufacturing all the wheels made and used by the Michigan Car Company. In 1879 the Griffin Car Wheel Company of Detroit was organized and a foundry built by T. F. Griffin, his father, associated with T. A. Griffin and P. H. Griffin. The following year Thomas A. Griffin went to Chicago, where he organized the Griffin & Wells Foundry Company, and in 1886 this company was merged into the Griffin Wheel & Foundry Company, Mr. Griffin at this time acquiring all of the interest in the Griffin Car Wheel Company at Detroit. Subsequently the name of the company was changed to Griffin Wheel Company. Besides having five foundries in Chicago the company operates foundries in Boston, St. Paul, Detroit, Kansas City, Denver and Tacoma, and a plant is being built at Los Angeles.



T. A. Griffin.

#### TRADE PUBLICATIONS.

**GEARS.**—The Mesta Machine Company, Pittsburgh, Pa., has devoted bulletin K to gears and rolling mill pinions. The little booklet contains illustrations of some of the gears made by the company and some of the processes in their manufacture.

**RAILWAY LAMPS AND LANTERNS.**—The Hiram L. Piper Company, Ltd., Montreal, has issued an 82-page catalog, illustrating the Hiram L. Piper train order signals and the company's line of railway lamps and lanterns, and other miscellaneous railway supplies.

**ELECTRICITY IN IRON FOUNDRIES.**—The General Electric Company, Schenectady, N. Y., has devoted bulletin A-4167 to the subject of electricity in iron foundries. The booklet is profusely illustrated with some typical applications of G-E motors in iron foundries, and contains a chapter on foundry lighting.

**REAMERS AND CHUCKS.**—The McCrosky Reamer Company, Meadville, Pa., has issued a very attractive and well illustrated catalog, describing some of the company's products, including the McCrosky adjustable reamer, the Wizard chuck and collet, the Wizard variable speed and reversing attachment, the McCrosky expanding mandrel and the Searchlight universal lamp brackets.

**CORRUGATED METAL CULVERTS.**—The Carolina Metal Products Company, Wilmington, N. C., has issued a 24-page booklet describing the Acme nestable corrugated metal culverts. Illustrations are given which show some of the possible uses of the product and a special point is made of the fact that the culverts are nestable and can therefore be transported very easily. This company, among its other products, also sells the Imperial riveted culvert.

**SELF-OPENING DIES.**—A catalog of 35 pages has been issued by Wells Brothers Company, Greenfield, Mass., dealing with the Wells self-opening dies. This book is well illustrated and includes views of the dies in detail, as well as assembled and in use on machines. It takes up such matters as the different types of chasers, errors in lead, relief, the cutting angle, etc. An inset shows four threads which were cut with this die, the greatest variation from perfect lead at any point on any of them being not over .001 in, per in.

**WIRES AND CABLES.**—The National India Rubber Company, 30 Church street, New York, has issued a 223 page catalog of rubber insulated and lead incased wires and cables. This book contains a great deal of valuable information, special attention having been given to the matter of illustrations which include considerable color work. It is accompanied by a card containing twenty samples of silk used in the covering of wire, each having a number and name for facility in ordering. Tables are included which give the freight on various sizes of wires and cables to the different states in the Union. The book also gives specifications for coverings for different classes of cables, as well as the more important extracts from the rules and requirements of the National Board of Fire Underwriters. A section is also included containing formulas and tables relating to wires and cables.

**AN ENGLISH IDEA FOR LUBRICATING RAILS ON CURVES.**—An English contemporary noting that 15 barrels of grease are used each month to lubricate rails on curves in the New York subway, and that the tracks on the curves at Times Square are greased five times every 24 hours, remarks that in England they have gone us one better in this respect. On the Liverpool Overhead and on some other railways, the rails are automatically lubricated by an ingenious arrangement as the trains pass. There is a grease box by the side of the track with a deflection bar attached to the rail. Every wheel that passes over the bar depresses it and that actuates a ratchet and pawl, causing a spur of grease to be placed on the side of the wheel before it reaches the guard rail.

**AN UNDERGROUND ELECTRIC RAILWAY IN ARGENTINA.**—On December 2 the president of the republic of Argentina, in the presence of an important gathering of the authorities and the general public, officially inaugurated the new underground line in Buenos Ayres. The line is over two miles long and runs under the main street of the city from Plaza Mayo to Plaza Once, the terminus of the Buenos Ayres Western. It is reported that the subway is already in fine working order. The cars and stations are well ventilated and lighted and the trains travel with good speed. The people of the city are most enthusiastic, and one reason may lie in the fact that they were allowed to ride free for the first five or six days. This is the first underground electric railway in South America.

# Railway Construction.

**CANADIAN NORTHERN.**—The Canadian parliament is being asked to extend the time for the construction and completion of lines, as follows: From Regina, Sask., southwesterly to a point on the international boundary between ranges 1 and 4, west 3rd meridian; from a point on the Rossburn branch near Russel, westerly through Yorkton, Sask., to a point on the authorized line near Goose lake; from a point 10 miles north of the line between Winnipeg and Ste. Anne, southerly to the Manitoba boundary, between ranges 2 and 4; from a point on the authorized line at or near Battleford, Sask., westerly to a point on the head waters of the Brazeau river; from a point near Regina, Sask., northerly to Humboldt, thence northeasterly down or near the valley of the Carrot river to a point at or near Pas, on the Saskatchewan river, and from a point on the line between Humboldt and the South Saskatchewan river northerly to a point at or near the crossing of the South Saskatchewan river by the Prince Albert branch. Authority is also asked for the construction of the following lines: From Calgary, Alta., westerly to Cochrane, Exshaw and Banff, from Cochrane northerly to intersect the company's line near Pigeon lake; from Cochrane southerly to Nanton, Alta. Extension of time is also being asked for the construction of lines from the authorized line between Port Arthur and Sudbury near the head of Long lake, northerly and westerly to connect with the National Transcontinental east of Lake Nipigon, Ont.; and from the authorized line between Ottawa and North Bay, near the township of Chisholm, southeasterly to the Central Ontario at or between Bancroft and Whitney, Ont.; and also the line from Port Dover to Kincardine, Ont.

Application is being made by the Central Ontario to the Canadian parliament for an extension of time for the completion of the line from the end of the present line at Central Ontario Jct., on the Canadian Pacific, to a junction with the Canadian Pacific at a point between Sudbury Jct., and Callander, Ont. G. Collins, Trenton, Ont., is general manager of the Central Ontario.

**CHICAGO, MILWAUKEE & ST. PAUL.**—An officer writes that a contract has been given to the J. H. Flick Construction Company, Chicago, to build a 10-mile logging road from Merrill, Wis., northwest.

**DAN RIVER RAILWAY (Electric).**—This company has been organized in North Carolina with \$500,000 capital, it is said, to build interurban railways in Stokes and adjacent counties in North Carolina. The incorporators include H. Miller, Clemmons, and E. T. Knapp, Bethania.

**EAST & WEST COAST.**—An officer writes that grading work is now under way on the line from Bradentown, Fla., southeast to Arcadia, 53 miles, and the company expects to begin track laying about February 1. Allen W. Jones, president and general contractor, Bradentown. (October 17, p. 727.)

**FORT WORTH-DENTON INTERURBAN.**—Application has been made for a charter in Texas, it is said, to build a 32-mile line from Fort Worth, Tex., north to Denton. E. Davidson, Fort Worth, Tex., is said to be interested.

**ILLINOIS MIDLAND.**—Incorporated in Illinois with \$25,000 capital and headquarters at Chicago, to build from the southern border of Kankakee county, Illinois, northwest to Rockford, about 120 miles. The directors include S. N. Ware, L. V. Zielke, Chicago; S. G. Durant, Philadelphia, and F. S. Munroe, Rockford.

**MESKILL & COLUMBIA RIVER.**—An officer of this company, which started work last year on a line from Meskill, Wash., to Grays river, 30 miles, writes that track was laid during 1913 on the section from Mays to Hope creek, 2.5 miles, and surveys are being made from Hope creek to Grays river, 14 miles. J. C. Dolphin, secretary, Meskill.

**OKLAHOMA ROADS.**—According to press reports plans are being made by residents of Grove, Okla., to organize a company for the purpose of building a railroad from Grove to Copeland.

**PACIFIC GREAT EASTERN.**—An officer writes that work is now under way by T. Welch, Vancouver, B. C., between Vancouver,

B. C., and Cheakamus, on 38 miles, also between Cheakamus and Clinton on 153 miles. Track has been laid on 18 miles and surveys are being made from Clinton to Fort George, 261 miles. The company was organized some time ago to build from Vancouver, B. C., to Ft. George, a total of 350 miles.

**PIEDMONT NORTHERN LINES (Electric).**—An officer writes that during 1913, this company laid 26 miles of new main track between Greenville, S. C., and Spartanburg, and work is now under way on five miles to complete this section. The Parker, Brooks Construction Company and Willard, Boggs & Company, both of Greenville, and J. Thomas Bennett, Spartanburg, are the contractors.

**ST. JOSEPH VALLEY.**—An officer of this company, which operates a line from Elkhart, Ind., east to Angola, 59 miles, writes that in addition to the extension completed from Angola, Ind., to Berlein, in the latter part of 1912, grading work has been extended from Berlein, east, 4 miles, and will be continued to a terminus in Ohio not yet determined upon. The construction work is being done by the company's forces.

**SALUDA-HENDERSONVILLE INTERURBAN.**—This company has been organized in North Carolina with \$150,000 capital, it is said, and headquarters at Kings Mountain, N. C. The plans call for building from Saluda, N. C., northwest to Hendersonville, about 10 miles. The incorporators include J. M. Torrance, Bessemer City, N. C.; C. E. Neisler, Kings Mountain, and U. G. Stanton, Hendersonville.

**WESTON & GLENVILLE (Electric).**—Incorporated in West Virginia with \$500,000 capital, it is said, to build from Weston, W. Va., southwest to Glenville, about 20 miles. The incorporators include A. Edmiston, L. Bennet, and L. Rinehart.

**A HIGH TENSION LINE FOR AFGHANISTAN.**—A project is now under way for transmitting 44,000 volts of electrical energy to Kabul, the capital of Afghanistan, from a fall about 120 ft. high at a point 40 miles away.

**OIL FUEL ON ARGENTINE RAILWAYS.**—The Buenos Ayres Great Southern and the Buenos Ayres & Pacific in Argentina have recently been experimenting with oil burning locomotives with, it is said, remarkable success.

**A NEW 800 MILE RAILWAY IN CHINA.**—It is reported that negotiations have recently been concluded by persons representing London interests, for financing the construction of an 800 mile railway in China from Shasi, on the Yangtze river, through Chang-te, Yuen-chow and Kwei-yang to Sing yi-fu, connecting with the French line to be built from Nankin to Yun-

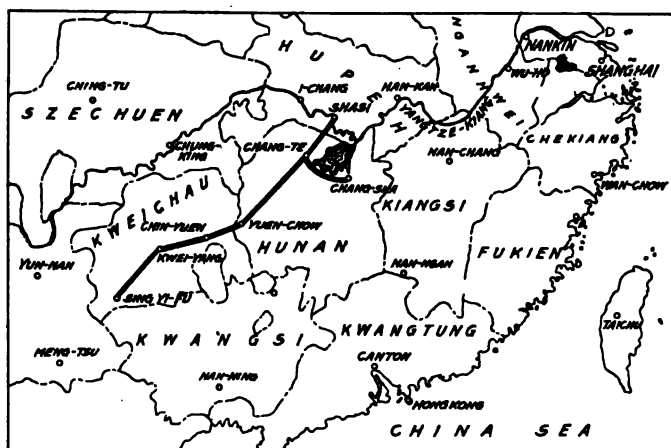

Portion of Map of China, Showing Proposed Road.

nan. There is also to be a branch from Chang-te to Chang-sha. The construction of this railway will inaugurate a definite railway system with Hankow or Han-kan as the center. The agreement is the first for constructing a railway in China with the contractors' profit provided for on a fixed percentage basis. Both of these ideas had been advocated by George B. Rea, an American.



## Railway Financial News.

**ATCHISON, TOPEKA & SANTA FE.**—This company has bought the St. Louis, El Reno & Western, which has been heretofore operated as part of the Fort Smith & Western. The St. Louis, El Reno & Western runs from Guthrie, Okla., to El Reno, 70 miles.

**BOSTON & MAINE.**—Theodore N. Vail, president of the American Telephone & Telegraph Company, who recently resigned as a director of the New York, New Haven & Hartford, has now resigned also as a director of the Boston & Maine.

President McDonald, of the Boston & Maine, has denied that there are any negotiations under way at the present time for the sale of control of the Boston & Maine to the Delaware & Hudson.

The directors of the Boston & Maine have written to the Massachusetts Public Service Commission in regard to the lease of the Hampden Railroad. The letter says in part: "Ratification at this time of President Mellen's execution of a lease to the Boston & Maine of the road and property of the Hampden Railroad corporation is not warranted, and the general solicitor is requested to communicate the action of the board of directors to the Public Service Commission of Massachusetts."

**CHICAGO & EASTERN ILLINOIS.**—The interest due January 1 on the 6 per cent. receiver's certificates is to be paid either at the Equitable Trust Company, New York, or the Continental & Commercial National Bank, Chicago. The additional \$2,000,000 receiver's certificates which the receivers have asked permission from the court to issue will not, it is understood, be issued until after January 1.

**CHICAGO, MILWAUKEE & ST. PAUL.**—This company is offering to exchange, par for par, its own 4 per cent. debenture bonds, due 1934, for first mortgage 5 per cent. bonds of the Idaho & Washington Northern, of which there are \$3,390,000 outstanding 5-year convertible 6 per cent. notes of the I. & W. N., of which there are outstanding \$1,200,000; and 4-year 6 per cent. notes of the I. & W. N., of which there are \$729,000 outstanding.

**DELAWARE & HUDSON.**—See Boston & Maine.

**DETROIT, TOLEDO & IRONTON.**—The *Wall Street Journal* publishes the following plan as worked out by committees representing several classes of bondholders of the Detroit, Toledo & Ironton:

The capitalization of the old company amounts to \$43,104,400. It is estimated that \$4,079,955 of new money will be required to pay six months' claims, taxes, receiver's certificates, and other obligations, and for cash working capital of the new company. It is proposed that this sum be raised by offering for subscription to the old bondholders the following securities of the new company: (1) Adjustment mortgage 5 per cent. 40-year gold bonds (total authorized, \$8,000,000), \$6,799,823; (2) preferred stock (total authorization \$6,000,000), \$5,132,582; (3) common stock (total \$6,500,000), \$5,633,408.

The proposed capitalization of the new company will be as follows: First mortgage 5 per cent. 50-year gold bonds, redeemable at 105 and accrued interest, at the option of the new company, and secured by the new company's first mortgage to the New York Trust Company, trustee, on all the property of the new company. The total amount of bonds to be issued is not to be limited, but it will be provided that \$1,000,000 shall be disposed of solely for the purpose of providing funds for rehabilitation of the property, and an additional \$1,000,000 for betterments and improvements to the property.

2. \$8,000,000 adjustment mortgage 5 per cent. 40-year bonds, the interest on which is to be cumulative after January 1, 1919. The bonds are redeemable as a whole at the option of the company at 70 per cent. of face value, and accrued interest during the first year; at 75 per cent. during the second year; 80 per cent. the third year; 85 per cent. the fourth year; and at 90 per cent. during the fifth year and at

par thereafter. All of the above redemptions are with accrued interest. The bonds are to be secured by a mortgage to the Central Trust Company subject to the prior lien of the first mortgage.

3. \$6,000,000 preferred stock, par \$100, and entitled to a 4 per cent. non-cumulative dividend and to share ratably with the common stock after the latter has received 4 per cent. in dividends in any year that surplus is in excess of the payments to both stocks.

4. \$6,500,000 common stock, par \$100, which shall be entitled to dividends after all charges have been paid and dividend requirements on the preferred stock have been met.

On the basis provided, owners of the various securities will receive in exchange for their holdings and for each \$1,000 paid the following:

Class of securities:	Adjustment Bonds.	Preferred Stock.	Common Stock.
Ohio Southern bonds.....	\$1,666.66	\$1,571.42	\$1,571.42
General lien bonds.....	1,666.66	1,428.57	1,428.57
General lien coupons, due Dec. 1, 1909 .....	1,666.66	800.00	1,200.00
Receivers' certificates, order of February 24, 1908.....	1,666.66	800.00	1,200.00
Consolidated bonds .....	1,666.66	500.00	1,000.00

Members of the reorganization committee are William Church Osborn, chairman; Otto T. Bannard, president New York Trust Company; Sydney C. Borg and F. H. Ecker.

**ERIE.**—This company has asked the New York Public Service Commission, Second district, for permission to issue \$2,000,000 general lien first consolidated mortgage bonds.

**HAMPDEN RAILROAD.**—See Boston & Maine.

**MINNEAPOLIS, ST. PAUL & SAULT STE. MARIE.**—This company has asked permission of the Wisconsin railroad commission to guarantee principal and interest \$1,280,000 equipment trust certificates, dated December 1, 1913, due semi-annually from December 1, 1914, to December 1, 1923.

**NEW ORLEANS, MOBILE & CHICAGO.**—W. F. Owen, president, has been appointed receiver on petition of the Metropolitan Trust Company, New York, trustee of the \$12,000,000 5 per cent. bonds, interest payment on which is now due and not paid. The road is controlled jointly by the St. Louis & San Francisco and the Louisville & Nashville.

**NEW YORK CENTRAL & HUDSON RIVER.**—The Public Utility Commission of New Jersey has given its permission for the new consolidation mortgage for \$167,000,000, which is incidental to the general plan of retirement of Lake Shore & Michigan Southern collateral trust 3½ per cent. bonds.

Holder of about \$59,000,000 of the Lake Shore & Michigan Southern collateral 3½ per cent. bonds have, it is understood, already consented to the plan, and consent from the holders of \$9,000,000 more will give the necessary three-quarters approval.

**PENNSYLVANIA RAILROAD.**—The total stockholders of the Pennsylvania now number 86,865. Of these stockholders more than 48 per cent. are women.

**ST. LOUIS, EL RENO & WESTERN.**—See Atchison, Topeka & Santa Fe.

**WESTERN MARYLAND.**—This company has asked permission of the Maryland Public Service Commission to issue \$5,000,000 18 months 6 per cent. notes, a part of the proceeds of which are to be used to pay off \$3,000,000 one-year notes which fall due January 1.

**DUTY FREE COAL FOR A RUSSIAN RAILWAY.**—The Russian cabinet has approved the importation, free of duty, of foreign coal for the need of the South-East Railway.

**RAILWAY STATION GARDENS IN ENGLAND.**—The Great Western awarded 19 prizes this year to station masters and others responsible for the upkeep of station gardens. The rivalry shown was so keen and the results so excellent that the company has decided to increase its annual prize allowance from \$1,250 to \$1,500. Eleven stations received the special prizes of \$25 apiece.

